

IBM Communications Server for Data Center  
Deployment on AIX  
Version 7.1

*Node Operator Facility Programmer's  
Guide*



**Note**

Before using this information and the product it supports, be sure to read the general information under [Appendix D, “Notices,” on page 667.](#)

**Seventh Edition (January 2021)**

This edition applies to IBM Communications Server for Data Center Deployment on AIX, Version 7.1, program number 5725-H32, and to all subsequent releases and modifications until otherwise indicated in new editions or technical newsletters.

Order publications through your IBM representative or the IBM branch office serving your locality. Publications are not stocked at the address below.

IBM welcomes your comments. A form for readers' comments is provided at the back of this publication. If the form has been removed, you may send your comments to the following address:

- International Business Machines Corporation
- Department CGMD
- P.O. Box 12195
- Research Triangle Park, North Carolina
- 27709-2195
- U.S.A.

If you prefer to send comments electronically, use one of the following methods:

- IBMLink: CIBMORCF at RALVM17
- IBM Mail: USIB2HPD at IBMMAIL
- Internet: USIB2HPD@vnet.ibm.com
- Fax: 1-800-227-5088

When you send information to IBM, you grant IBM a nonexclusive right to use or distribute the information in any way it believes appropriate without incurring any obligation to you.

© **Copyright International Business Machines Corporation 1998, 2021.**

US Government Users Restricted Rights – Use, duplication or disclosure restricted by GSA ADP Schedule Contract with IBM Corp.

---

# Contents

<b>Tables.....</b>	<b>xxix</b>
<b>Figures.....</b>	<b>xxxix</b>
<b>About this book.....</b>	<b>xxxiii</b>
Who should use this book.....	xxxiii
How to use this book.....	xxxiii
Organization of this book.....	xxxiii
Typographic conventions.....	xxxiv
Graphic conventions.....	xxxiv
Where to find more information.....	xxxv
<b>Chapter 1. Introduction to the NOF API.....</b>	<b>1</b>
Purpose of the NOF API.....	1
Node configuration file.....	2
Domain configuration file.....	2
Invokable TP data file.....	2
CS/AIX components.....	2
Client/Server operation.....	3
Controller server and backup servers.....	4
AIX or Linux clients.....	4
Windows Clients.....	5
NOF verbs to manage specific CS/AIX functions.....	5
Managing the target (node or file) for NOF verbs.....	5
Getting started.....	6
3270 communications.....	7
LUA communications.....	7
APPC communications.....	8
CPI-C communications.....	9
Managing HPR RTP connections.....	10
Managing SNA gateway.....	10
Managing DLUR.....	10
Managing TN server.....	11
Managing TN Redirector.....	12
Managing SNA management services functions.....	12
Managing access to the CS/AIX system from the host NetView program.....	13
Managing diagnostics settings.....	13
Managing directory entries.....	14
Querying the network topology.....	15
Checking the communications path to a remote LU.....	15
Managing servers and clients on the CS/AIX LAN.....	15
Managing configuration file header information.....	16
Managing AIX resource usage.....	16
NOF Indications.....	16
Configuration indications.....	17
SNA network file indications.....	17
NOF status indications.....	17
<b>Chapter 2. Writing NOF applications.....</b>	<b>19</b>

Client/Server considerations.....	19
AIX or Linux considerations .....	19
NOF API entry points for AIX or Linux.....	19
Compiling and linking the NOF application.....	24
Windows considerations.....	25
NOF API entry points for Windows.....	25
Compiling and linking the NOF application.....	29
Writing portable applications.....	30
Target for NOF verbs.....	30
Processing modes.....	31
Ordering and dependencies between NOF verbs.....	31
NOF restrictions based on node configuration.....	32
APPN end node and LEN node restrictions.....	32
Multiple Domain Support (MDS) restrictions.....	33
SNA gateway and DLUR restrictions.....	33
List options for QUERY_* Verbs.....	33
Obtaining information about a single resource or multiple resources.....	33
Obtaining summary or detailed information.....	34

### **Chapter 3. NOF API Verbs..... 35**

ACTIVATE_SESSION.....	35
VCB structure.....	36
Supplied parameters.....	36
Returned parameters: successful execution.....	37
Returned parameters: parameter check.....	37
Returned parameters: activation failure.....	37
Returned parameters: other conditions.....	38
ADD_BACKUP.....	38
VCB structure.....	38
Supplied parameters.....	38
Returned parameters: successful execution.....	38
Returned parameters: state check.....	39
Returned parameters: other conditions.....	39
ADD_DLC_TRACE.....	39
VCB structure.....	39
Supplied parameters.....	40
Returned parameters: successful execution.....	41
Returned parameters: parameter check.....	41
Returned parameters: other conditions.....	42
APING.....	42
VCB structure.....	42
Supplied parameters.....	42
Returned parameters: successful execution.....	44
Returned parameters: parameter check.....	44
Returned parameters: allocation failure.....	45
Returned parameters: conversation failure.....	45
Returned parameters: other conditions.....	46
CHANGE_SESSION_LIMIT.....	46
VCB structure.....	46
Supplied parameters.....	46
Returned parameters: successful execution.....	48
Returned parameters: parameter check.....	48
Returned parameters: state check.....	49
Returned parameters: session allocation error.....	49
Returned parameters: CNOS processing errors.....	49
Returned parameters: other conditions.....	49
CLOSE_FILE.....	50

VCB structure.....	50
Supplied parameters.....	50
Returned parameters: successful execution.....	50
Returned parameters: state check.....	50
Returned parameters: other conditions.....	50
CONNECT_NODE.....	51
VCB structure.....	51
Supplied parameters.....	51
Returned parameters: successful execution.....	51
Returned parameters: parameter check.....	52
Returned parameters: state check.....	52
Returned parameters: other conditions.....	52
DEACTIVATE_CONV_GROUP.....	52
VCB structure.....	53
Supplied parameters.....	53
Returned parameters: successful execution.....	53
Returned parameters: parameter check.....	53
Returned parameters: other conditions.....	54
DEACTIVATE_LU_0_TO_3.....	54
VCB structure.....	54
Supplied parameters.....	54
Returned parameters: successful execution.....	54
Returned parameters: parameter check.....	55
Returned parameters: other conditions.....	55
DEACTIVATE_SESSION.....	55
VCB structure.....	55
Supplied parameters.....	55
Returned parameters: successful execution.....	56
Returned parameters: parameter check.....	56
Returned parameters: other conditions.....	57
DEFINE_ADJACENT_LEN_NODE.....	57
VCB structure.....	57
Supplied parameters.....	57
Returned parameters: successful execution.....	58
Returned parameters: parameter check.....	58
Returned parameters: state check.....	59
Returned parameters: other conditions.....	59
DEFINE_CN.....	59
VCB structure.....	59
Supplied parameters.....	60
Returned parameters: successful execution.....	61
Returned parameters: parameter check.....	61
Returned parameters: state check.....	62
Returned parameters: function not supported.....	62
Returned parameters: other conditions.....	62
DEFINE_COS.....	62
VCB structure.....	62
Supplied parameters.....	63
Returned parameters: successful execution.....	66
Returned parameters: parameter check.....	66
Returned parameters: state check.....	67
Returned parameters: other conditions.....	67
DEFINE_CPIC_SIDE_INFO.....	67
VCB structure.....	67
Supplied parameters.....	68
Returned parameters: successful execution.....	69
Returned parameters: parameter check.....	69
Returned parameters: other conditions.....	69

DEFINE_DEFAULT_PU.....	69
VCB structure.....	70
Supplied parameters.....	70
Returned parameters: successful execution.....	70
Returned parameters: other conditions.....	70
DEFINE_DEFAULTS.....	70
VCB structure.....	70
Supplied parameters.....	71
Returned parameters: successful execution.....	71
Returned parameters: parameter check.....	71
Returned parameters: other conditions.....	72
DEFINE_DIRECTORY_ENTRY.....	72
VCB structure.....	72
Supplied parameters.....	72
Returned parameters: successful execution.....	73
Returned parameters: parameter check.....	73
Returned parameters: other conditions.....	74
DEFINE_DLC.....	74
VCB structure.....	74
Supplied parameters.....	75
Returned parameters: successful execution.....	78
Returned parameters: parameter check.....	79
Returned parameters: state check.....	79
Returned parameters: other conditions.....	79
DEFINE_DLUR_DEFAULTS.....	79
VCB structure.....	79
Supplied parameters.....	80
Returned parameters: successful execution.....	80
Returned parameters: parameter check.....	80
Returned parameters: function not supported.....	81
Returned parameters: other conditions.....	81
DEFINE_DOMAIN_CONFIG_FILE.....	81
VCB structure.....	81
Supplied parameters.....	81
Returned parameters: successful execution.....	82
Returned parameters: other conditions.....	82
DEFINE_DOWNSTREAM_LU.....	82
VCB structure.....	82
Supplied parameters.....	82
Returned parameters: successful execution.....	83
Returned parameters: parameter check.....	84
Returned parameters: state check.....	84
Returned parameters: function not supported.....	85
Returned parameters: other conditions.....	85
DEFINE_DOWNSTREAM_LU_RANGE.....	85
VCB structure.....	85
Supplied parameters.....	85
Returned parameters: successful execution.....	86
Returned parameters: parameter check.....	86
Returned parameters: state check.....	87
Returned parameters: function not supported.....	87
Returned parameters: other conditions.....	88
DEFINE_DSPU_TEMPLATE.....	88
VCB structure.....	88
Supplied parameters.....	88
Returned parameters: successful execution.....	89
Returned parameters: parameter check.....	90
Returned parameters: state check.....	90

Returned parameters: function not supported.....	90
Returned parameters: other conditions.....	91
DEFINE_FOCAL_POINT.....	91
VCB structure.....	91
Supplied parameters.....	91
Returned parameters: successful execution.....	92
Returned parameters: parameter check.....	92
Returned parameters: function not supported.....	92
Returned parameters: replaced.....	92
Returned parameters: unsuccessful.....	92
Returned parameters: other conditions.....	93
DEFINE_INTERNAL_PU.....	93
VCB structure.....	93
Supplied parameters.....	93
Returned parameters: successful execution.....	95
Returned parameters: parameter check.....	95
Returned parameters: state check.....	95
Returned parameters: function not supported.....	95
Returned parameters: other conditions.....	96
DEFINE_LOCAL_LU.....	96
VCB structure.....	96
Supplied parameters.....	96
Returned parameters: successful execution.....	98
Returned parameters: parameter check.....	98
Returned parameters: state check.....	99
Returned parameters: other conditions.....	99
Default LUs.....	99
DEFINE_LS.....	100
VCB structure.....	100
Supplied parameters.....	104
Returned parameters: successful execution.....	122
Returned parameters: parameter check.....	122
Returned parameters: state check.....	124
Returned parameters: other conditions.....	125
Bit ordering in MAC addresses.....	125
Modem control characters.....	126
DEFINE_LS_ROUTING.....	127
VCB structure.....	127
Supplied parameters.....	127
Returned parameters: successful execution.....	128
Returned parameters: parameter check.....	128
Returned parameters: state check.....	128
Returned parameters: other conditions.....	128
DEFINE_LU62_TIMEOUT.....	129
VCB structure.....	129
Supplied parameters.....	129
Returned parameters: successful execution.....	129
Returned parameters: parameter check.....	130
Returned parameters: other conditions.....	130
DEFINE_LU_0_TO_3.....	130
VCB structure.....	130
Supplied parameters.....	131
Returned parameters: successful execution.....	133
Returned parameters: parameter check.....	133
Returned parameters: state check.....	133
Returned parameters: other conditions.....	134
DEFINE_LU_0_TO_3_RANGE.....	134
VCB structure.....	134

Supplied parameters.....	134
Returned parameters: successful execution.....	137
Returned parameters: parameter check.....	137
Returned parameters: state check.....	137
Returned parameters: other conditions.....	138
DEFINE_LU_LU_PASSWORD.....	138
VCB structure.....	138
Supplied parameters.....	138
Returned parameters: successful execution.....	139
Returned parameters: parameter check.....	139
Returned parameters: other conditions.....	139
DEFINE_LU_POOL.....	140
VCB structure.....	140
Supplied parameters.....	140
Returned parameters: successful execution.....	140
Returned parameters: parameter check.....	140
Returned parameters: state check.....	141
Returned parameters: other conditions.....	141
DEFINE_MODE.....	141
VCB structure.....	141
Supplied parameters.....	142
Returned parameters: successful execution.....	144
Returned parameters: parameter check.....	144
Returned parameters: other conditions.....	145
DEFINE_NODE.....	145
VCB structure.....	145
Supplied parameters.....	146
Returned parameters: successful execution.....	155
Returned parameters: parameter check.....	155
Returned parameters: state check.....	156
Returned parameters: other conditions.....	156
DEFINE_PARTNER_LU.....	156
VCB structure.....	156
Supplied parameters.....	157
Returned parameters: successful execution.....	158
Returned parameters: parameter check.....	158
Returned parameters: state check.....	158
Returned parameters: other conditions.....	158
DEFINE_PORT.....	159
VCB structure.....	159
Supplied parameters.....	163
Returned parameters: successful execution.....	172
Returned parameters: parameter check.....	172
Returned parameters: state check.....	173
Returned parameters: other conditions.....	174
Incoming calls.....	174
DEFINE_RCF_ACCESS.....	174
VCB structure.....	174
Supplied parameters.....	174
Returned parameters: successful execution.....	175
Returned parameters: parameter check.....	175
Returned parameters: other conditions.....	175
DEFINE_RTP_TUNING.....	175
VCB structure.....	176
Supplied parameters.....	176
Returned parameters: successful execution.....	177
Returned parameters: parameter check.....	177
Returned parameters: other conditions.....	177



DEFINE_SECURITY_ACCESS_LIST.....	177
VCB structure.....	178
Supplied parameters.....	178
Returned parameters: successful execution.....	179
Returned parameters: parameter check.....	179
Returned parameters: other conditions.....	179
DEFINE_TN3270_ACCESS.....	179
VCB structure.....	179
Supplied parameters.....	180
Returned parameters: successful execution.....	184
Returned parameters: parameter check.....	184
Returned parameters: other conditions.....	185
Using the Telnet Daemon's TCP/IP Port.....	185
DEFINE_TN3270_ASSOCIATION.....	185
VCB structure.....	185
Supplied parameters.....	186
Returned parameters: successful execution.....	186
Returned parameters: parameter check.....	186
Returned parameters: other conditions.....	187
DEFINE_TN3270_DEFAULTS.....	187
VCB structure.....	187
Supplied parameters.....	187
Returned parameters: successful execution.....	188
Returned parameters: parameter check.....	188
Returned parameters: other conditions.....	188
DEFINE_TN3270_EXPRESS_LOGON.....	188
VCB structure.....	189
Supplied parameters.....	189
Returned parameters: successful execution.....	189
Returned parameters: other conditions.....	189
DEFINE_TN3270_SLP.....	190
VCB structure.....	190
Supplied parameters.....	190
Returned parameters: successful execution.....	191
Returned parameters: parameter check.....	192
Returned parameters: other conditions.....	192
DEFINE_TN3270_SSL_LDAP.....	192
VCB structure.....	192
Supplied parameters.....	193
Returned parameters: successful execution.....	193
Returned parameters: parameter check.....	194
Returned parameters: function not supported.....	194
Returned parameters: other conditions.....	194
DEFINE_TN_REDIRECT.....	194
VCB structure.....	194
Supplied parameters.....	195
Returned parameters: successful execution.....	199
Returned parameters: parameter check.....	199
Returned parameters: other conditions.....	199
DEFINE_TP.....	199
VCB structure.....	200
Supplied parameters.....	200
Returned parameters: successful execution.....	201
Returned parameters: parameter check.....	202
Returned parameters: state check.....	202
Returned parameters: other conditions.....	202
DEFINE_TP_LOAD_INFO.....	202
VCB structure.....	202

Supplied parameters.....	203
Returned parameters: successful execution.....	204
Returned parameters: parameter check.....	204
Returned parameters: other conditions.....	205
DEFINE_USERID_PASSWORD.....	205
VCB structure.....	205
Supplied parameters.....	205
Returned parameters: successful execution.....	206
Returned parameters: parameter check.....	206
Returned parameters: other conditions.....	207
DELETE_ADJACENT_LEN_NODE.....	207
VCB structure.....	207
Supplied parameters.....	207
Returned parameters: successful execution.....	208
Returned parameters: parameter check.....	208
Returned parameters: state check.....	208
Returned parameters: other conditions.....	208
DELETE_BACKUP.....	208
VCB structure.....	208
Supplied parameters.....	209
Returned parameters: successful execution.....	209
Returned parameters: state check.....	209
Returned parameters: other conditions.....	209
DELETE_CN.....	209
VCB structure.....	210
Supplied parameters.....	210
Returned parameters: successful execution.....	210
Returned parameters: parameter check.....	210
Returned parameters: function not supported.....	211
Returned parameters: other conditions.....	211
DELETE_COS.....	211
VCB structure.....	211
Supplied parameters.....	211
Returned parameters: successful execution.....	211
Returned parameters: parameter check.....	211
Returned parameters: other conditions.....	212
DELETE_CPIC_SIDE_INFO.....	212
VCB structure.....	212
Supplied parameters.....	212
Returned parameters: successful execution.....	212
Returned parameters: state check.....	212
Returned parameters: other conditions.....	213
DELETE_DIRECTORY_ENTRY.....	213
VCB structure.....	213
Supplied parameters.....	213
Returned parameters: successful execution.....	214
Returned parameters: parameter check.....	214
Returned parameters: state check.....	214
Returned parameters: other conditions.....	214
DELETE_DLC.....	214
VCB structure.....	214
Supplied parameters.....	215
Returned parameters: successful execution.....	215
Returned parameters: parameter check.....	215
Returned parameters: state check.....	215
Returned parameters: other conditions.....	215
DELETE_DOWNSTREAM_LU.....	215
VCB structure.....	216

Supplied parameters.....	216
Returned parameters: successful execution.....	216
Returned parameters: parameter check.....	216
Returned parameters: state check.....	216
Returned parameters: function not supported.....	217
Returned parameters: other conditions.....	217
DELETE_DOWNSTREAM_LU_RANGE.....	217
VCB structure.....	217
Supplied parameters.....	217
Returned parameters: successful execution.....	217
Returned parameters: parameter check.....	218
Returned parameters: state check.....	218
Returned parameters: function not supported.....	218
Returned parameters: other conditions.....	218
DELETE_DSPU_TEMPLATE.....	218
VCB structure.....	219
Supplied parameters.....	219
Returned parameters: successful execution.....	220
Returned parameters: parameter check.....	220
Returned parameters: other conditions.....	220
DELETE_FOCAL_POINT.....	220
VCB structure.....	220
Supplied parameters.....	220
Returned parameters: successful execution.....	221
Returned parameters: parameter check.....	221
Returned parameters: function not supported.....	221
Returned parameters: other conditions.....	221
DELETE_INTERNAL_PU.....	222
VCB structure.....	222
Supplied parameters.....	222
Returned parameters: successful execution.....	222
Returned parameters: parameter check.....	222
Returned parameters: state check.....	222
Returned parameters: function not supported.....	223
Returned parameters: other conditions.....	223
DELETE_LOCAL_LU.....	223
VCB structure.....	223
Supplied parameters.....	223
Returned parameters: successful execution.....	223
Returned parameters: parameter check.....	223
Returned parameters: other conditions.....	224
DELETE_LS.....	224
VCB structure.....	224
Supplied parameters.....	224
Returned parameters: successful execution.....	224
Returned parameters: parameter check.....	224
Returned parameters: state check.....	225
Returned parameters: other conditions.....	225
DELETE_LS_ROUTING.....	225
VCB structure.....	225
Supplied parameters.....	225
Returned parameters: successful execution.....	226
Returned parameters: parameter check.....	226
Returned parameters: state check.....	226
Returned parameters: other conditions.....	227
DELETE_LU62_TIMEOUT.....	227
VCB structure.....	227
Supplied parameters.....	227

Returned parameters: successful execution.....	227
Returned parameters: parameter check.....	228
Returned parameters: other conditions.....	228
DELETE_LU_0_TO_3.....	228
VCB structure.....	228
Supplied parameters.....	228
Returned parameters: successful execution.....	229
Returned parameters: parameter check.....	229
Returned parameters: state check.....	229
Returned parameters: other conditions.....	229
DELETE_LU_0_TO_3_RANGE.....	229
VCB structure.....	229
Supplied parameters.....	230
Returned parameters: successful execution.....	230
Returned parameters: parameter check.....	230
Returned parameters: state check.....	231
Returned parameters: other conditions.....	231
DELETE_LU_LU_PASSWORD.....	231
VCB structure.....	231
Supplied parameters.....	231
Returned parameters: successful execution.....	232
Returned parameters: parameter check.....	232
Returned parameters: other conditions.....	232
DELETE_LU_POOL.....	232
VCB structure.....	232
Supplied parameters.....	232
Returned parameters: successful execution.....	233
Returned parameters: parameter check.....	233
Returned parameters: other conditions.....	233
DELETE_MODE.....	233
VCB structure.....	233
Supplied parameters.....	234
Returned parameters: successful execution.....	234
Returned parameters: parameter check.....	234
Returned parameters: other conditions.....	234
DELETE_PARTNER_LU.....	234
VCB structure.....	234
Supplied parameters.....	235
Returned parameters: successful execution.....	235
Returned parameters: parameter check.....	235
Returned parameters: other conditions.....	235
DELETE_PORT.....	235
VCB structure.....	235
Supplied parameters.....	236
Returned parameters: successful execution.....	236
Returned parameters: parameter check.....	236
Returned parameters: state check.....	236
Returned parameters: other conditions.....	236
DELETE_RCF_ACCESS.....	236
VCB structure.....	237
Supplied parameters.....	237
Returned parameters: successful execution.....	237
Returned parameters: other conditions.....	237
DELETE_SECURITY_ACCESS_LIST.....	237
VCB structure.....	237
Supplied parameters.....	238
Returned parameters: successful execution.....	238
Returned parameters: parameter check.....	238

Returned parameters: other conditions.....	238
DELETE_TN3270_ACCESS.....	238
VCB structure.....	239
Supplied parameters.....	239
Returned parameters: successful execution.....	240
Returned parameters: parameter check.....	240
Returned parameters: other conditions.....	240
DELETE_TN3270_ASSOCIATION.....	240
VCB structure.....	241
Supplied parameters.....	241
Returned parameters: successful execution.....	241
Returned parameters: parameter check.....	241
Returned parameters: state check.....	241
Returned parameters: other conditions.....	241
DELETE_TN_REDIRECT.....	242
VCB structure.....	242
Supplied parameters.....	242
Returned parameters: successful execution.....	243
Returned parameters: parameter check.....	243
Returned parameters: other conditions.....	243
DELETE_TP.....	243
VCB structure.....	243
Supplied parameters.....	243
Returned parameters: successful execution.....	244
Returned parameters: parameter check.....	244
Returned parameters: other conditions.....	244
DELETE_TP_LOAD_INFO.....	244
VCB structure.....	244
Supplied parameters.....	244
Returned parameters: successful execution.....	245
Returned parameters: parameter check.....	245
Returned parameters: other conditions.....	245
DELETE_USERID_PASSWORD.....	245
VCB structure.....	245
Supplied parameters.....	246
Returned parameters: successful execution.....	246
Returned parameters: parameter check.....	246
Returned parameters: other conditions.....	246
DISCONNECT_NODE.....	247
VCB structure.....	247
Supplied parameters.....	247
Returned parameters: successful execution.....	247
Returned parameters: state check.....	247
Returned parameters: other conditions.....	247
INIT_NODE.....	248
VCB structure.....	248
Supplied parameters.....	248
Returned parameters: successful execution.....	248
Returned parameters: parameter check.....	248
Returned parameters: state check.....	248
Returned parameters: other conditions.....	249
INITIALIZE_SESSION_LIMIT.....	249
VCB structure.....	249
Supplied parameters.....	249
Returned parameters: successful execution.....	251
Returned parameters: parameter check.....	251
Returned parameters: state check.....	251
Returned parameters: session allocation error.....	252

Returned parameters: CNOS processing errors.....	252
Returned parameters: other conditions.....	252
OPEN_FILE.....	252
VCB structure.....	252
Supplied parameters.....	253
Returned parameters: successful execution.....	253
Returned parameters: parameter check.....	254
Returned parameters: state check.....	254
Returned parameters: other conditions.....	254
PATH_SWITCH.....	254
VCB structure.....	255
Supplied parameters.....	255
Returned parameters: successful execution.....	255
Returned parameters: parameter check.....	255
Returned parameters: state check.....	255
Returned parameters: path switch disabled.....	255
Returned parameters: path switch failure.....	256
Returned parameters: node check.....	256
Returned parameters: other conditions.....	256
QUERY_ACTIVE_TRANSACTION.....	256
VCB structure.....	256
Supplied parameters.....	257
Returned parameters: successful execution.....	258
Returned parameters: parameter check.....	259
Returned parameters: function not supported.....	259
Returned parameters: other conditions.....	259
QUERY_ADJACENT_NN.....	259
VCB structure.....	259
Supplied parameters.....	260
Returned parameters: successful execution.....	260
Returned parameters: parameter check.....	261
Returned parameters: function not supported.....	262
Returned parameters: other conditions.....	262
QUERY_AVAILABLE_TP.....	262
VCB structure.....	262
Supplied parameters.....	263
Returned parameters: successful execution.....	263
Returned parameters: parameter check.....	264
Returned parameters: other conditions.....	264
QUERY_BUFFER_AVAILABILITY.....	264
VCB structure.....	264
Supplied parameters.....	265
Returned parameters: successful execution.....	265
Returned parameters: other conditions.....	266
QUERY_CENTRAL_LOGGER.....	266
VCB structure.....	267
Supplied parameters.....	267
Returned parameters: successful execution.....	267
Returned parameters: state check.....	267
Returned parameters: other conditions.....	267
QUERY_CENTRAL_LOGGING.....	267
VCB structure.....	267
Supplied parameters.....	268
Returned parameters: successful execution.....	268
Returned parameters: parameter check.....	268
State check.....	268
Returned parameters: other conditions.....	268
QUERY_CN.....	269

VCB structure.....	269
Supplied parameters.....	270
Returned parameters: successful execution.....	270
Returned parameters: parameter check.....	272
Returned parameters: function not supported.....	272
Returned parameters: other conditions.....	272
QUERY_CN_PORT.....	273
VCB structure.....	273
Supplied parameters.....	273
Returned parameters: successful execution.....	274
Returned parameters: parameter check.....	274
Returned parameters: function not supported.....	275
Returned parameters: other conditions.....	275
QUERY_CONVERSATION.....	275
VCB structure.....	275
Supplied parameters.....	276
Returned parameters: successful execution.....	277
Returned parameters: parameter check.....	278
Returned parameters: other conditions.....	278
QUERY_COS.....	279
VCB structure.....	279
Supplied parameters.....	279
Returned parameters: successful execution.....	280
Returned parameters: parameter check.....	281
Returned parameters: other conditions.....	281
QUERY_COS_NODE_ROW.....	281
VCB structure.....	281
Supplied parameters.....	282
Returned parameters: successful execution.....	283
Returned parameters: parameter check.....	284
Returned parameters: other conditions.....	284
QUERY_COS_TG_ROW.....	284
VCB structure.....	285
Supplied parameters.....	285
Returned parameters: successful execution.....	286
Returned parameters: parameter check.....	289
Returned parameters: other conditions.....	289
QUERY_CPIC_SIDE_INFO.....	289
VCB structure.....	289
Supplied parameters.....	290
Returned parameters: successful execution.....	290
Returned parameters: parameter check.....	292
Returned parameters: state check.....	292
Returned parameters: other conditions.....	292
QUERY_CS_TRACE.....	293
VCB structure.....	293
Supplied parameters.....	293
Returned parameters: successful execution.....	293
Returned parameters: parameter check.....	294
Returned parameters: other conditions.....	294
QUERY_DEFAULT_PU.....	294
VCB structure.....	294
Supplied parameters.....	295
Returned parameters: successful execution.....	295
Returned parameters: node not started.....	295
Returned parameters: other conditions.....	295
QUERY_DEFAULTS.....	295
VCB structure.....	295

Supplied parameters.....	296
Returned parameters: successful execution.....	296
Returned parameters: node not started.....	297
Returned parameters: other conditions.....	297
QUERY_DIRECTORY_ENTRY.....	297
VCB structure.....	297
Supplied parameters.....	298
Returned parameters: successful execution.....	299
Returned parameters: parameter check.....	302
Returned parameters: other conditions.....	303
QUERY_DIRECTORY_LU.....	303
VCB structure.....	303
Supplied parameters.....	304
Returned parameters: successful execution.....	304
Returned parameters: parameter check.....	306
Returned parameters: other conditions.....	307
QUERY_DIRECTORY_STATS.....	307
VCB structure.....	307
Supplied parameters.....	307
Returned parameters: successful execution.....	307
Returned parameters: other conditions.....	308
QUERY_DLC.....	308
VCB structure.....	308
Supplied parameters.....	309
Returned parameters: successful execution.....	310
Returned parameters: parameter check.....	312
Returned parameters: other conditions.....	313
QUERY_DLC_TRACE.....	313
VCB structure.....	313
Supplied parameters.....	313
Returned parameters: successful execution.....	315
Returned parameters: parameter check.....	317
Returned parameters: other conditions.....	317
QUERY_DLUR_DEFAULTS.....	317
VCB structure.....	317
Supplied parameters.....	317
Returned parameters: successful execution.....	318
Returned parameters: function not supported.....	318
Returned parameters: other conditions.....	318
QUERY_DLUR_LU.....	318
VCB structure.....	318
Supplied parameters.....	319
Returned parameters: successful execution.....	320
Returned parameters: parameter check.....	321
Returned parameters: function not supported.....	322
Returned parameters: other conditions.....	322
QUERY_DLUR_PU.....	322
VCB structure.....	322
Supplied parameters.....	323
Returned parameters: successful execution.....	324
Returned parameters: parameter check.....	327
Returned parameters: function not supported.....	327
Returned parameters: other conditions.....	327
QUERY_DLUS.....	327
VCB structure.....	328
Supplied parameters.....	328
Returned parameters: successful execution.....	329
Returned parameters: parameter check.....	331



Returned parameters: function not supported.....	331
Returned parameters: other conditions.....	331
QUERY_DOMAIN_CONFIG_FILE.....	331
VCB structure.....	331
Supplied parameters.....	332
Returned parameters: successful execution.....	332
Returned parameters: other conditions.....	332
QUERY_DOWNSTREAM_LU.....	332
VCB structure.....	332
Supplied parameters.....	334
Returned parameters: successful execution.....	335
Returned parameters: parameter check.....	338
Returned parameters: state check.....	339
Returned parameters: function not supported.....	339
Returned parameters: other conditions.....	339
QUERY_DOWNSTREAM_PU.....	339
VCB structure.....	339
Supplied parameters.....	340
Returned parameters: successful execution.....	341
Returned parameters: parameter check.....	343
Returned parameters: function not supported.....	343
Returned parameters: other conditions.....	343
QUERY_DSPU_TEMPLATE.....	343
VCB structure.....	343
Supplied parameters.....	344
Returned parameters: successful execution.....	345
Returned parameters: parameter check.....	346
Returned parameters: other conditions.....	346
QUERY_FOCAL_POINT.....	346
VCB structure.....	346
Supplied parameters.....	347
Returned parameters: successful execution.....	348
Returned parameters: parameter check.....	350
Returned parameters: function not supported.....	350
Returned parameters: other conditions.....	350
QUERY_GLOBAL_LOG_TYPE.....	350
VCB structure.....	351
Supplied parameters.....	351
Returned parameters: successful execution.....	351
Returned parameters: parameter check.....	352
Returned parameters: other conditions.....	352
QUERY_ISR_SESSION.....	352
VCB structure.....	352
Supplied parameters.....	354
Returned parameters: successful execution.....	355
Returned parameters: parameter check.....	359
Returned parameters: function not supported.....	359
Returned parameters: other conditions.....	359
QUERY_KERNEL_MEMORY_LIMIT.....	359
VCB structure.....	359
Supplied parameters.....	359
Returned parameters: successful execution.....	360
Returned parameters: other conditions.....	360
QUERY_LOCAL_LU.....	360
VCB structure.....	361
Supplied parameters.....	362
Returned parameters: successful execution.....	363
Returned parameters: parameter check.....	366

Returned parameters: other conditions.....	367
QUERY_LOCAL_TOPOLOGY.....	367
VCB structure.....	367
Supplied parameters.....	368
Returned parameters: successful execution.....	369
Returned parameters: parameter check.....	371
Returned parameters: other conditions.....	372
QUERY_LOG_FILE.....	372
VCB structure.....	372
Supplied parameters.....	372
Returned parameters: successful execution.....	372
Returned parameters: parameter check.....	373
Returned parameters: other conditions.....	373
QUERY_LOG_TYPE.....	373
VCB structure.....	374
Supplied parameters.....	374
Returned parameters: successful execution.....	374
Returned parameters: other conditions.....	375
QUERY_LS.....	375
VCB structure.....	375
Supplied parameters.....	378
Returned parameters: successful execution.....	379
Returned parameters: parameter check.....	395
Returned parameters: other conditions.....	395
QUERY_LS_ROUTING.....	395
VCB structure.....	395
Supplied parameters.....	396
Returned parameters: successful execution.....	397
Returned parameters: parameter check.....	397
Returned parameters: other conditions.....	397
QUERY_LU_0_TO_3.....	397
VCB structure.....	398
Supplied parameters.....	400
Returned parameters: successful execution.....	401
Returned parameters: parameter check.....	409
Returned parameters: other conditions.....	409
QUERY_LU_LU_PASSWORD.....	409
VCB structure.....	409
Supplied parameters.....	410
Returned parameters: successful execution.....	411
Returned parameters: parameter check.....	412
Returned parameters: other conditions.....	412
QUERY_LU_POOL.....	412
VCB structure.....	412
Supplied parameters.....	413
Returned parameters: successful execution.....	414
Returned parameters: parameter check.....	415
Returned parameters: other conditions.....	416
QUERY_LU62_TIMEOUT.....	416
VCB structure.....	416
Supplied parameters.....	417
Returned parameters: successful execution.....	418
Returned parameters: parameter check.....	418
Returned parameters: other conditions.....	419
QUERY_MDS_APPLICATION.....	419
VCB structure.....	419
Supplied parameters.....	419
Returned parameters: successful execution.....	420

Returned parameters: parameter check.....	421
Returned parameters: function not supported.....	421
Returned parameters: other conditions.....	421
QUERY_MDS_STATISTICS.....	421
VCB structure.....	421
Supplied parameters.....	422
Returned parameters: successful execution.....	422
Returned parameters: function not supported.....	423
Returned parameters: other conditions.....	423
QUERY_MODE.....	423
VCB structure.....	423
Supplied parameters.....	424
Returned parameters: successful execution.....	425
Returned parameters: parameter check.....	428
Returned parameters: other conditions.....	428
QUERY_MODE_DEFINITION.....	429
VCB structure.....	429
Supplied parameters.....	430
Returned parameters: successful execution.....	430
Returned parameters: parameter check.....	433
Returned parameters: other conditions.....	433
QUERY_MODE_TO_COS_MAPPING.....	433
VCB structure.....	433
Supplied parameters.....	434
Returned parameters: successful execution.....	434
Returned parameters: parameter check.....	435
Returned parameters: other conditions.....	435
QUERY_NMVT_APPLICATION.....	435
VCB structure.....	435
Supplied parameters.....	436
Returned parameters: successful execution.....	436
Returned parameters: parameter check.....	437
Returned parameters: other conditions.....	438
QUERY_NN_TOPOLOGY_NODE.....	438
VCB structure.....	438
Supplied parameters.....	438
Returned parameters: successful execution.....	440
Returned parameters: parameter check.....	442
Returned parameters: function not supported.....	442
Returned parameters: other conditions.....	442
QUERY_NN_TOPOLOGY_STATS.....	443
VCB structure.....	443
Supplied parameters.....	443
Returned parameters: successful execution.....	443
Returned parameters: function not supported.....	445
Returned parameters: other conditions.....	445
QUERY_NN_TOPOLOGY_TG.....	445
VCB structure.....	446
Supplied parameters.....	447
Returned parameters: successful execution.....	448
Returned parameters: parameter check.....	452
Returned parameters: function not supported.....	452
Returned parameters: other conditions.....	452
QUERY_NODE.....	452
VCB structure.....	452
Supplied parameters.....	454
Returned parameters: successful execution.....	454
Returned parameters: other conditions.....	464

QUERY_NODE_ALL.....	464
VCB structure.....	464
Supplied parameters.....	465
Returned parameters: successful execution.....	465
Returned parameters: parameter check.....	466
Returned parameters: other conditions.....	466
QUERY_NODE_LIMITS.....	466
VCB structure.....	467
Supplied parameters.....	467
Returned parameters: successful execution.....	467
Returned parameters: other conditions.....	469
QUERY_PARTNER_LU.....	469
VCB structure.....	470
Supplied parameters.....	470
Returned parameters: successful execution.....	472
Returned parameters: parameter check.....	475
Returned parameters: other conditions.....	475
QUERY_PARTNER_LU_DEFINITION.....	475
VCB structure.....	475
Supplied parameters.....	476
Returned parameters: successful execution.....	477
Returned parameters: parameter check.....	479
Returned parameters: other conditions.....	479
QUERY_PORT.....	479
VCB structure.....	479
Supplied parameters.....	481
Returned parameters: successful execution.....	482
Returned parameters: parameter check.....	487
Returned parameters: other conditions.....	487
QUERY_PU.....	487
VCB structure.....	487
Supplied parameters.....	488
Returned parameters: successful execution.....	489
Returned parameters: parameter check.....	491
Returned parameters: state check.....	492
Returned parameters: other conditions.....	492
QUERY_RAPI_CLIENTS.....	492
VCB structure.....	492
Supplied parameters.....	493
Returned parameters: successful execution.....	493
Returned parameters: parameter check.....	495
Returned parameters: other conditions.....	495
QUERY_RCF_ACCESS.....	495
VCB structure.....	495
Supplied parameters.....	496
Returned parameters: successful execution.....	496
Returned parameters: other conditions.....	496
QUERY_RTP_CONNECTION.....	496
VCB structure.....	497
Supplied parameters.....	498
Returned parameters: successful execution.....	499
Returned parameters: parameter check.....	503
Returned parameters: other conditions.....	503
QUERY_RTP_TUNING.....	503
VCB structure.....	504
Supplied parameters.....	504
Returned parameters: successful execution.....	504
Returned parameters: other conditions.....	505

QUERY_SECURITY_ACCESS_LIST.....	505
VCB structure.....	505
Supplied parameters.....	505
Returned parameters: successful execution.....	506
Returned parameters: parameter check.....	507
Returned parameters: other conditions.....	508
QUERY_SESSION.....	508
VCB structure.....	508
Supplied parameters.....	509
Returned parameters: successful execution.....	511
Returned parameters: parameter check.....	514
Returned parameters: other conditions.....	515
QUERY_SNA_NET.....	515
VCB structure.....	515
Supplied parameters.....	515
Returned parameters: successful execution.....	516
Returned parameters: parameter check.....	517
Returned parameters: state check.....	517
Returned parameters: other conditions.....	517
QUERY_STATISTICS.....	517
VCB structure.....	518
Supplied parameters.....	518
Returned parameters: successful execution.....	519
Returned parameters: parameter check.....	520
Returned parameters: state check.....	520
Returned parameters: function not supported.....	520
Returned parameters: other conditions.....	521
QUERY_TN3270_ACCESS_DEF.....	521
VCB structure.....	521
Supplied parameters.....	522
Returned parameters: successful execution.....	523
Returned parameters: parameter check.....	525
Returned parameters: other conditions.....	526
QUERY_TN3270_ASSOCIATION.....	526
VCB structure.....	526
Supplied parameters.....	526
Returned parameters: successful execution.....	527
Returned parameters: parameter check.....	527
Returned parameters: other conditions.....	528
QUERY_TN3270_DEFAULTS.....	528
VCB structure.....	528
Supplied parameters.....	528
Returned parameters: successful execution.....	528
Returned parameters: other conditions.....	529
QUERY_TN3270_EXPRESS_LOGON.....	529
VCB structure.....	529
Supplied parameters.....	530
Returned parameters: successful execution.....	530
Returned parameters: other conditions.....	530
QUERY_TN3270_SLP.....	530
VCB structure.....	530
Supplied parameters.....	531
Returned parameters: successful execution.....	531
Returned parameters: other conditions.....	532
QUERY_TN3270_SLP_TRACE.....	532
VCB structure.....	532
Supplied parameters.....	532
Returned parameters: successful execution.....	532

Returned parameters: other conditions.....	533
QUERY_TN3270_SSL_LDAP.....	533
VCB structure.....	533
Supplied parameters.....	534
Returned parameters: successful execution.....	534
Returned parameters: other conditions.....	534
QUERY_TN_REDIRECT_DEF.....	535
VCB structure.....	535
Supplied parameters.....	535
Returned parameters: successful execution.....	536
Returned parameters: parameter check.....	537
Returned parameters: other conditions.....	537
QUERY_TN_SERVER_TRACE.....	537
VCB structure.....	537
Supplied parameters.....	537
Returned parameters: successful execution.....	537
Returned parameters: other conditions.....	538
QUERY_TP.....	538
VCB structure.....	538
Supplied parameters.....	539
Returned parameters: successful execution.....	539
Returned parameters: parameter check.....	540
Returned parameters: other conditions.....	541
QUERY_TP_DEFINITION.....	541
VCB structure.....	541
Supplied parameters.....	541
Returned parameters: successful execution.....	542
Returned parameters: parameter check.....	544
Returned parameters: other conditions.....	545
QUERY_TP_LOAD_INFO.....	545
VCB structure.....	545
Supplied parameters.....	545
Returned parameters: successful execution.....	546
Returned parameters: parameter check.....	547
Returned parameters: other conditions.....	547
QUERY_TRACE_FILE.....	548
VCB structure.....	548
Supplied parameters.....	548
Returned parameters: successful execution.....	548
Returned parameters: parameter check.....	549
Returned parameters: other conditions.....	549
QUERY_TRACE_TYPE.....	549
VCB structure.....	549
Supplied parameters.....	550
Returned parameters: successful execution.....	550
Returned parameters: other conditions.....	551
QUERY_USERID_PASSWORD.....	551
VCB structure.....	551
Supplied parameters.....	551
Returned parameters: successful execution.....	552
Returned parameters: parameter check.....	553
Returned parameters: other conditions.....	553
REGISTER_INDICATION_SINK.....	553
VCB structure.....	554
Supplied parameters.....	554
Returned parameters: successful execution.....	554
Returned parameters: parameter check.....	554
Returned parameters: function not supported.....	555

Returned parameters: other conditions.....	555
REMOVE_DLC_TRACE.....	555
VCB structure.....	555
Supplied parameters.....	556
Returned parameters: successful execution.....	557
Returned parameters: parameter check.....	557
Returned parameters: other conditions.....	558
RESET_SESSION_LIMIT.....	558
VCB structure.....	558
Supplied parameters.....	558
Returned parameters: successful execution.....	560
Returned parameters: parameter check.....	560
Returned parameters: state check.....	561
Returned parameters: session allocation error.....	561
Returned parameters: CNOS processing errors.....	561
Returned parameters: other conditions.....	562
SET_BUFFER_AVAILABILITY.....	562
VCB structure.....	562
Supplied parameters.....	562
Returned parameters: successful execution.....	562
Returned parameters: other conditions.....	562
SET_CENTRAL_LOGGING.....	562
VCB structure.....	562
Supplied parameters.....	563
Returned parameters: successful execution.....	563
Returned parameters: parameter check.....	563
Returned parameters: other conditions.....	563
SET_CS_TRACE.....	563
VCB structure.....	564
Supplied parameters.....	564
Returned parameters: successful execution.....	565
Returned parameters: parameter check.....	565
Returned parameters: other conditions.....	565
SET_GLOBAL_LOG_TYPE.....	565
VCB structure.....	566
Supplied parameters.....	566
Returned parameters: successful execution.....	567
Returned parameters: parameter check.....	567
Returned parameters: other conditions.....	567
SET_KERNEL_MEMORY_LIMIT.....	567
VCB structure.....	568
Supplied parameters.....	568
Returned parameters: successful execution.....	568
Returned parameters: other conditions.....	568
SET_LOG_FILE.....	568
VCB structure.....	569
Supplied parameters.....	569
Returned parameters: successful execution.....	570
Returned parameters: parameter check.....	570
Returned parameters: other conditions.....	571
SET_LOG_TYPE.....	571
VCB structure.....	571
Supplied parameters.....	571
Returned parameters: successful execution.....	572
Returned parameters: parameter check.....	573
Returned parameters: other conditions.....	573
SET_PROCESSING_MODE.....	573
VCB structure.....	573

Supplied parameters.....	573
Returned parameters: successful execution.....	574
Returned parameters: parameter check.....	574
Returned parameters: state check.....	574
Returned parameters: other conditions.....	575
SET_TN3270_SLP_TRACE.....	575
VCB structure.....	575
Supplied parameters.....	575
Returned parameters: successful execution.....	576
Returned parameters: other conditions.....	576
SET_TN_SERVER_TRACE.....	576
VCB structure.....	576
Supplied parameters.....	576
Returned parameters: successful execution.....	577
Returned parameters: other conditions.....	577
SET_TRACE_FILE.....	577
VCB structure.....	577
Supplied parameters.....	577
Returned parameters: successful execution.....	578
Returned parameters: parameter check.....	579
Returned parameters: other conditions.....	579
SET_TRACE_TYPE.....	579
VCB structure.....	579
Supplied parameters.....	579
Returned parameters: successful execution.....	581
Returned parameters: parameter check.....	581
Returned parameters: other conditions.....	581
Trace types.....	581
START_DLC.....	583
VCB structure.....	583
Supplied parameters.....	583
Returned parameters: successful execution.....	583
Returned parameters: parameter check.....	583
Returned parameters: state check.....	583
Returned parameters: other conditions.....	584
START_INTERNAL_PU.....	584
VCB structure.....	584
Supplied parameters.....	584
Returned parameters: successful execution.....	585
Returned parameters: parameter check.....	585
Returned parameters: state check.....	585
Returned parameters: unsuccessful.....	585
Returned parameters: function not supported.....	586
Returned parameters: other conditions.....	586
START_LS.....	586
VCB structure.....	586
Supplied parameters.....	586
Returned parameters: successful execution.....	587
Returned parameters: parameter check.....	587
Returned parameters: state check.....	587
Returned parameters: unsuccessful.....	588
Returned parameters: cancelled.....	588
Returned parameters: other conditions.....	588
START_PORT.....	588
VCB structure.....	589
Supplied parameters.....	589
Returned parameters: successful execution.....	589
Returned parameters: parameter check.....	589



Returned parameters: state check.....	589
Returned parameters: cancelled.....	590
Returned parameters: other conditions.....	590
STOP_DLC.....	590
VCB structure.....	590
Supplied parameters.....	590
Returned parameters: successful execution.....	590
Returned parameters: parameter check.....	590
Returned parameters: state check.....	591
Returned parameters: cancelled.....	591
Returned parameters: other conditions.....	591
STOP_INTERNAL_PU.....	591
VCB structure.....	591
Supplied parameters.....	592
Returned parameters: successful execution.....	592
Returned parameters: parameter check.....	592
Returned parameters: state check.....	592
Returned parameters: function not supported.....	592
Returned parameters: other conditions.....	593
STOP_LS.....	593
VCB structure.....	593
Supplied parameters.....	593
Returned parameters: successful execution.....	594
Returned parameters: parameter check.....	594
Returned parameters: state check.....	594
Returned parameters: cancelled.....	594
Returned parameters: other conditions.....	594
STOP_PORT.....	594
VCB structure.....	595
Supplied parameters.....	595
Returned parameters: successful execution.....	595
Returned parameters: parameter check.....	595
Returned parameters: state check.....	595
Returned parameters: cancelled.....	596
Returned parameters: other conditions.....	596
TERM_NODE.....	596
VCB structure.....	596
Supplied parameters.....	596
Returned parameters: successful execution.....	597
Returned parameters: other conditions.....	597
UNREGISTER_INDICATION_SINK.....	597
VCB structure.....	597
Supplied parameters.....	597
Returned parameters: successful execution.....	597
Returned parameters: parameter check.....	598
Returned parameters: function not supported.....	598
Returned parameters: other conditions.....	598

**Chapter 4. NOF Indications..... 599**

CONFIG_INDICATION.....	599
VCB structure.....	599
DIRECTORY_INDICATION.....	600
VCB structure.....	600
Parameters.....	600
DLC_INDICATION.....	602
VCB structure.....	602
Parameters.....	603

DLUR_LU_INDICATION.....	603
VCB structure.....	603
Parameters.....	603
DLUR_PU_INDICATION.....	604
VCB structure.....	604
Parameters.....	604
DLUS_INDICATION.....	606
VCB structure.....	606
Parameters.....	607
DOWNSTREAM_LU_INDICATION.....	608
VCB structure.....	608
Parameters.....	609
DOWNSTREAM_PU_INDICATION.....	611
VCB structure.....	611
Parameters.....	611
FOCAL_POINT_INDICATION.....	613
VCB structure.....	613
Parameters.....	613
ISR_INDICATION.....	614
VCB structure.....	614
Parameters.....	615
LOCAL_LU_INDICATION.....	617
VCB structure.....	617
Parameters.....	618
LOCAL_TOPOLOGY_INDICATION.....	620
VCB structure.....	620
Parameters.....	620
LS_INDICATION.....	621
VCB structure.....	622
Parameters.....	622
LU_0_TO_3_INDICATION.....	625
VCB structure.....	625
Parameters.....	626
MODE_INDICATION.....	628
VCB structure.....	628
Parameters.....	628
NN_TOPOLOGY_NODE_INDICATION.....	629
VCB structure.....	629
Parameters.....	629
NN_TOPOLOGY_TG_INDICATION.....	630
VCB structure.....	630
Parameters.....	630
NOF_STATUS_INDICATION.....	632
VCB structure.....	632
Parameters.....	632
PLU_INDICATION.....	633
VCB structure.....	633
Parameters.....	633
PORT_INDICATION.....	634
VCB structure.....	634
Parameters.....	634
PU_INDICATION.....	635
VCB structure.....	635
Parameters.....	635
RAPI_CLIENT_INDICATION.....	637
VCB structure.....	637
Parameters.....	638
REGISTRATION_FAILURE.....	639

VCB structure.....	639
Parameters.....	639
RTP_INDICATION.....	640
VCB structure.....	640
Parameters.....	641
SERVER_INDICATION.....	644
VCB structure.....	644
Parameters.....	644
SESSION_INDICATION.....	645
VCB structure.....	645
Parameters.....	646
SNA_NET_INDICATION.....	648
VCB structure.....	649
TN_REDIRECTION_INDICATION.....	649
VCB structure.....	649
Parameters.....	649
<b>Appendix A. Return code values.....</b>	<b>653</b>
Primary return codes.....	653
Secondary return codes.....	654
<b>Appendix B. Common return codes.....</b>	<b>661</b>
Communications subsystem not active.....	661
Indication.....	661
Invalid function.....	662
Invalid verb segment.....	662
Parameter check.....	662
State check.....	663
System error.....	663
<b>Appendix C. How to send your comments to IBM.....</b>	<b>665</b>
Email feedback template.....	665
If you have a technical problem.....	665
<b>Appendix D. Notices.....</b>	<b>667</b>
Trademarks.....	668
<b>Bibliography.....</b>	<b>671</b>
CS/AIX version 7.1 publications.....	671
IBM Redbooks.....	672
AIX operating system publications.....	672
Systems Network Architecture (SNA) publications.....	673
Host configuration publications.....	673
z/OS Communications Server publications.....	673
TCP/IP publications.....	673
X.25 publications.....	673
APPC publications.....	674
Programming publications.....	674
Other IBM networking publications.....	674
<b>Index.....</b>	<b>675</b>



---

# Tables

1. Typographic Conventions.....	xxxiv
2. Escape Sequences for Modem Control Characters.....	126



---

# Figures

- 1. CS/AIX Components..... 3
- 2. Overall Structure of CS/AIX..... 582





## About this book

---

*IBM Communications Server for Data Center Deployment on AIX NOF Programmer's Guide* contains the information required to develop C-language application programs that use the Node Operator Facility (NOF) API to manage IBM Communications Server for Data Center Deployment on AIX resources. IBM Communications Server for Data Center Deployment on AIX, program product number 5725-H32, is an IBM® software product that enables a server running AIX® to exchange information with other nodes on an SNA network.

This book applies to Version 7.1 of CS/AIX running on AIX Version 7.2 or later.

## Who should use this book

---

This book is intended for experienced C programmers who write Systems Network Architecture (SNA) transaction programs for systems with CS/AIX.

This book is intended for System Administrators and application programmers who use CS/AIX.

### System Administrators

System Administrators install CS/AIX, configure the system for network connection, and maintain the system. They should be familiar with the hardware on which CS/AIX operates and with the AIX operating system. They must also be knowledgeable about the network to which the system is connected and understand SNA concepts in general.

### Application Programmers

Application programmers design and code transaction and application programs that use the CS/AIX programming interfaces to send and receive data over an SNA network. They should be thoroughly familiar with SNA, the remote program with which the transaction or application program communicates, and the AIX or Linux operating system programming and operating environments.

More detailed information about writing application programs is provided in the manual for each API. For additional information about CS/AIX publications, see the Bibliography.

## How to use this book

---

This section explains how information is organized and presented in this book.

## Organization of this book

This book is organized as follows:

- [Chapter 1, “Introduction to the NOF API,”](#) on page 1, provides an overview of the CS/AIX NOF API and the functions it provides.
- [Chapter 2, “Writing NOF applications,”](#) on page 19, contains general information a programmer needs when writing NOF applications and information about compiling and linking the applications.
- [Chapter 3, “NOF API Verbs,”](#) on page 35, provides a detailed description of each of the NOF verbs, including parameters and return codes.
- [Chapter 4, “NOF Indications,”](#) on page 599, provides a detailed description of each of the indications that a NOF application can register to receive.
- [Appendix A, “Return code values,”](#) on page 653, lists all the possible return codes in the NOF interface in numerical order and gives their meanings.
- [Appendix B, “Common return codes,”](#) on page 661, provides information about return codes that are common to all the NOF verbs.

## Typographic conventions

Table 1 on page xxxiv shows the typographic styles used in this document.

Table 1. Typographic Conventions

Special Element	Sample of Typography
Document title	<i>IBM Communications Server for Data Center Deployment on AIX NOF Programmer's Guide</i>
File or path name	sna.err
Directory name	/var/sna
Header file	nof_c.h
Program or application	snaadmin
Command	define_local_lu; cd
General reference to all verbs of a particular type	DEFINE_* (indicates all of the NOF API verbs that define resources)
Option or flag	-I
Parameter	opcode
Literal value or selection that the user can enter (including default values)	255
Constant	AP_MODE_READ_ONLY
Return value	AP_INVALID_FORMAT; 0
Variable representing a supplied value	a.b.c.d
Environment variable	LD_RUN_PATH
Programming verb	CONNECT_NODE
User input	snaadmin status_dependent_lu, pu_name=ETH0
Function, call, or entry point	ioctl
Data structure	NOF_CALLBACK
Hexadecimal value	0x20

## Graphic conventions



This symbol is used to indicate the start of a section of text that applies only to the AIX or Linux operating system. It applies to AIX servers and to the IBM Remote API Client running on AIX, Linux, Linux for Power or Linux for IBM Z.



This symbol is used to indicate the start of a section of text that applies to the IBM Remote API Client on Windows.



This symbol indicates the end of a section of operating system specific text. The information following this symbol applies regardless of the operating system.

## Where to find more information

---

See the Bibliography for other books in the CS/AIX library, as well as books that contain additional information about topics related to SNA and AIX workstations.

## Where to find more information

---

## Chapter 1. Introduction to the NOF API

This chapter provides an introduction to the CS/AIX NOF API. It includes the following information:

- Purpose of the NOF API
- Client/server operation
- NOF verbs and indications

For information about the CS/AIX components and resources accessed by the NOF API, see *IBM Communications Server for Data Center Deployment on AIX Quick Beginnings*.

---

### Purpose of the NOF API

The CS/AIX NOF API provides access to a standard set of commands, called NOF verbs, that can be used to administer the CS/AIX system from within an application program. These verbs enable you to define and delete resources, specify CS/AIX parameters such as diagnostics levels and file names, start and stop defined resources, query the definition or current status of resources, and manage which servers on the CS/AIX LAN can act as backup controllers if the controlling configuration file server is not available.

In a client/server system, you can use any NOF verbs in an application running on a server. Applications running on Remote API Clients can use NOF verbs to query configuration or status information, but cannot use other verbs to modify the configuration or to start or stop resources.

The NOF verbs provide the same functions as commands issued to the command-line administration program `snaadmin`, or as records in a CS/AIX configuration file. For example, the NOF verb `DEFINE_LOCAL_LU` is equivalent both to a `define_local_lu` command issued to the `snaadmin` program, and to a `define_local_lu` record in a configuration file; all three of them perform the same function, which is to specify the parameters of a CS/AIX local APPC LU.

You can use the Motif administration program `xsnaadmin` or the Web administration program to perform the same function as a NOF verb or an administration command (for example, to define a local APPC LU). However, this does not provide access to the full range of parameters included in some NOF verbs. For more information about using the Motif administration program or the Web administration program, refer to the *IBM Communications Server for Data Center Deployment on AIX Administration Guide*.

You can issue NOF verbs to any of the following targets:

- A running CS/AIX node - to manage its resources or to monitor its operation
- A server where the node is not running - to query the stored configuration or to modify it for use when the node is next started
- The CS/AIX domain as a whole - to define, modify, or query the configuration of domain resources (resources used to support particular user programs, such as CPI-C side information entries, which are not associated with a particular node).
- The CS/AIX invokable TP data file - to define information that CS/AIX needs to start invokable (target) TPs, or to define other information relating to a TP (such as the level of security required to access the TP).

The NOF API enables you to do the following:

- Develop your own application programs to manage the CS/AIX system
- Develop application programs that use the other CS/AIX APIs so that they can also manage their own resources (for example, an APPC application can check that the communications link to its partner TP is active before attempting to allocate a conversation or can define the remote LU where its partner TP is located).

### Node configuration file

Configuration information for each CS/AIX node is held in a text file on the computer where the node runs. This file includes information about the node's resources, and specifies which resources will be active when CS/AIX is started. When you start the node, the file provides an initial definition of the resources that are available; you can then use the NOF API or the CS/AIX administration tools to modify the running node's resources as your requirements change.

You can set up multiple configuration files, to store different CS/AIX configurations for use at different times, and select which of these files to use when starting the CS/AIX software.

Configuration in an APPN network is a dynamic process; you can add, delete, or modify resources as necessary while the CS/AIX software is running. The configuration file provides an initial definition of the available resources and stores the current definition so that you can use it again when you need to restart the node, but it is not necessary to define the entire configuration before starting the CS/AIX software.

### Domain configuration file

Configuration information for CS/AIX domain resources is held in a single text file on the controller server. You can set up multiple domain configuration files, to store different CS/AIX configurations for use at different times, and select which of these files to use when starting the CS/AIX software on the controller server.

Configuration in an APPN network is a dynamic process; you can add, delete, or modify resources as necessary while the system is running. The domain configuration file provides an initial definition of the available domain resources and enables you to store the current definition so that you can use it again when you need to restart the system, but it is not necessary to define the entire domain configuration before starting the CS/AIX software or to restart the software when you make changes.

### Invokable TP data file

Information that CS/AIX needs to start invokable (target) TPs is held in the file `/etc/sna/sna_tps` (AIX) or `/etc/opt/ibm/sna/sna_tps` (Linux). This file can also provide other information (such as the level of security required to access the TP). The invokable TP data file resides on the computer where the TPs run.

## CS/AIX components

---

CS/AIX implements an APPN node to communicate with other nodes on the SNA network. This provides logical unit (LU) 6.2 support for APPC and CPI-C capabilities, as well as LU 0, 1, 2, and 3 support for 3270 and LUA communications.

CS/AIX can operate as any of the APPN node types LEN, end, network, or branch network node, depending on its configuration. Certain functions are supported only on particular node types, as defined by the APPN architecture. These differences are indicated where necessary in this manual; where no differences are indicated, the information applies to all node types.

[Figure 1 on page 3](#), shows the components of CS/AIX and how they work together.

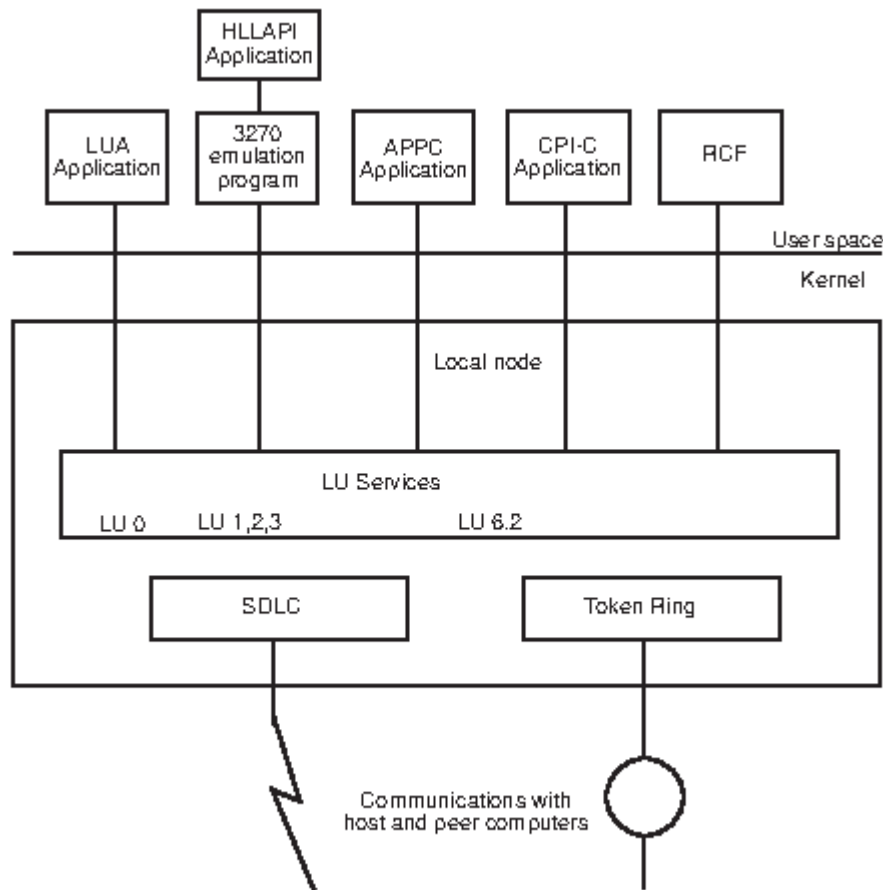

Figure 1. CS/AIX Components

The local node, including its associated connectivity resources (DLCs, ports and LSS), is implemented as CS/AIX components in the kernel of the AIX system.

The APPC transaction programs, CPI-C applications, LUA applications, and the Remote Command Facility (RCF) are user-space programs. CS/AIX supports multiple APPC TPs, CPI-C applications, and LUA applications, running concurrently.

## Client/Server operation

The computers on the CS/AIX network are of two types: servers and clients. A server contains a CS/AIX node and its associated connectivity components; a client does not contain these connectivity components, but accesses them on the server by means of the network. Servers are AIX computers; clients can be running AIX, Linux, or Windows. (An AIX or Linux computer can be either a server or a client, but not both; you cannot install both the server and the client on the same computer.) Servers and clients communicate across the network using Berkeley Software Distribution (BSD) Sockets.

Each CS/AIX network, referred to as a domain, is identified by a domain name. This name is specified during the installation of each CS/AIX computer (server or client), so that all computers in a single CS/AIX network have the same domain name. To install two separate CS/AIX domains on the same physical network, you simply use two different domain names to identify the domain in which each computer belongs. A single CS/AIX domain can correspond to a TCP/IP subnet, can be part of a TCP/IP subnet (so that there are two or more separate CS/AIX domains in the same subnet), or can span multiple subnets.

Each server maintains information about its own node configuration in a node configuration file. You can use the CS/AIX administration tools or the NOF API to examine the node's configuration. This can be done either from this server or from any other computer in the domain, as long as the SNA software is running (whether or not the node is started). You can also use the CS/AIX administration tools or the NOF API on

## Client/Server operation

this server or on any other server to modify the node's configuration or to start or stop resources on the node.

Information about the configuration of domain resources for the complete CS/AIX network is held in a domain configuration file. If you have more than one server on the network, CS/AIX ensures that this information is consistent across all servers.

## Controller server and backup servers

If you are using CS/AIX with all programs on one computer or on a network that contains only one server, you do not need to read this section.

At any time, one server on the network, known as the controller server, holds the controlling copy of the CS/AIX domain configuration file. You can define other servers on the network to be backup servers; the domain configuration file is copied to backup servers (either when they are started or when the controlling copy is changed) so that all backup servers hold a copy of the latest information.

If the controller server fails or if the SNA software on that computer is stopped, a backup server takes over as the controller. The domain configuration file on this server is used as the controlling copy and is copied to other servers as necessary. When the controller server is restarted, it receives a copy of the domain configuration from the backup server currently acting as controller and then takes over as the controller.

In general, define at least one backup server in addition to the controller server. Any remaining servers can be defined as additional backup servers or they can be left as peer servers. A peer server obtains configuration information from the controller server as required but cannot act as a backup server.

If at any time the controller server and all backup servers are inactive, a node on a peer server can still operate, and you can still change the node's configuration. However, you cannot access the domain configuration file and therefore cannot access the configuration of domain resources (as opposed to node resources). This means that you will not be able to allocate CPI-C conversations using symbolic destination names defined in the configuration file.

There is one situation in which CS/AIX cannot maintain a consistent configuration of domain resources across the network; it is your responsibility to maintain the configuration in this case. This situation occurs when the network is split by a network failure into two noncommunicating domains, each containing one or more backup servers. In this situation, there will be an acting controller server in each domain, which will hold any changes made to the domain configuration file in that domain but will be unaware of any changes made in the other domain. When the network connection is re-established, the domain configuration file from the original controller server (or from the highest backup server available in either of the two domains if the controller is inactive at this point) will become the domain configuration file across the network; this will overwrite any changes made to the domain configuration file in the other domain while the network was split. Because of this, do not attempt to make any changes to the domain configuration file in either of the two domains while the network connection is broken. Changes can be made to the configuration of individual nodes.

CS/AIX stores information about the controller server and backup servers in the file `sna.net`, known as the SNA network data file. The controlling copy of this file is stored on the controller server; any changes made to it are automatically copied to all other servers, in the same way that changes to the domain configuration file are copied to backup servers. You cannot edit the contents of the file directly; instead, CS/AIX provides NOF verbs to access the file.

For more information about the SNA network data file, refer to the *IBM Communications Server for Data Center Deployment on AIX Administration Command Reference*.

CS/AIX clients can run either on AIX, Linux or Windows systems or within containers on these systems (or AIX WPARs). CS/AIX Servers cannot run within containers since they have Unix kernel dependencies.

## AIX or Linux clients

Clients may be running inside Containers on the AIX or Linux Operating System on inside AIX WPARs.



A client computer does not contain any configuration file or the SNA network data file; it holds only the information it needs to access servers on the CS/AIX network and relies on a server to provide the necessary configuration information.

The SNA network information required is held in the file `/etc/sna/sna_c1nt.net` (AIX) or `/etc/opt/ibm/sna/sna_c1nt.net` (Linux). For more information about this file, refer to the *IBM Communications Server for Data Center Deployment on AIX Administration Command Reference*.

On a client, you can use the NOF API to query configuration, initialize or activate sessions, and manage local logging and tracing options. You cannot modify a node's configuration, or start or stop resources on the node.

## Windows Clients

Clients may be running inside Containers on the Windows Operating System.

The CS/AIX Windows Client software can be installed on machines running Microsoft Windows 10 (64-bit), Windows Server 2012, Windows Server 2016, or Windows Server 2019. Configuration information required by Windows Clients is managed through the Windows Registry.

For more information about the Windows Registry, and about managing Windows clients, refer to the *IBM Communications Server for Data Center Deployment on AIX Administration Guide*.

On a client, you can use the NOF API to query configuration, initialize or activate sessions, and manage local logging and tracing options. You cannot modify a node's configuration, or start or stop resources on the node.

## NOF verbs to manage specific CS/AIX functions

---

The following sections list the NOF verbs that are relevant to particular CS/AIX functions. For more information about individual verbs, see [Chapter 3, “NOF API Verbs,” on page 35](#).

### Managing the target (node or file) for NOF verbs

A NOF verb can be issued to a node, to the domain configuration file, or to the SNA network data file. To access the target node or file, use one of the following verbs:

- OPEN\_FILE
- CONNECT\_NODE

When you issue the verbs shown above to access the target, you are initially restricted to issuing verbs that query the configuration; you cannot issue verbs to modify it. If the NOF application is running on a server (not on a client), you can obtain write access to the target node or file so that you can issue verbs that modify the configuration. Use the following verb:

- SET\_PROCESSING\_MODE

To register for indications when the target configuration changes, use the following verb:

- REGISTER\_INDICATION\_SINK

To unregister when indications are no longer required, use the following verb:

- UNREGISTER\_INDICATION\_SINK

To release the target node or file when you have finished issuing NOF verbs, use one of the following verbs:

- DISCONNECT\_NODE, CLOSE\_FILE

You can issue OPEN\_FILE, CONNECT\_NODE, DISCONNECT\_NODE, and CLOSE\_FILE verbs, and NOF QUERY verbs, from an application running on a client, as well as from an application running on a server. You cannot issue any other NOF verbs from the client.

### Getting started

The first step is to define the CS/AIX node that runs on each computer, and its communications links to other computers. To define these components, use the following verbs:

- DEFINE\_NODE
- DEFINE\_DLC, DEFINE\_PORT, DEFINE\_LS

After defining these components, activate them to establish the link to the remote system. (DLCs, ports, and LSs can be defined to be "initially active" using the DEFINE\_\* verbs described previously, so that they are started automatically when the node is started; in this case, it is not necessary to start them manually.) To activate components, use the following verbs:

- INIT\_NODE
- START\_DLC, START\_PORT, START\_LS

The components must be started in the order shown because each component relies on the one before it.

To stop these components when access to the remote system is no longer required, use the following verbs:

- STOP\_LS, STOP\_PORT, STOP\_DLC

To obtain information about the configuration or current status of these components, use the following verbs:

- QUERY\_NODE
- QUERY\_DLC, QUERY\_PORT, QUERY\_LS

To obtain information about the usage of an LS, use the following verb:

- QUERY\_STATISTICS

To delete connectivity components when they are no longer required, use the following verbs:

- DELETE\_DLC, DELETE\_PORT, DELETE\_LS

If you are communicating with many nodes on the same shared-access transport facility (SATF), you can set up a connection network (CN) to represent these nodes, instead of having to define explicit LSs to each node. CNs cannot be used if the local node is a LEN node.

To set up the CN, you first define a DLC and port to access each of the nodes on the SATF.

You then define a CN that includes all these ports; you do not need to define any LSs because a dynamic LS to the CN will be set up as required. To define the CN, or to add ports to an existing CN, use the following verb:

- DEFINE\_CN

To obtain information about defined CNs, or about the ports on a CN, use the following verbs:

- QUERY\_CN, QUERY\_CN\_PORT

To delete a CN when it is no longer required, or to remove ports from a CN without deleting the CN, use the following verb:

- DELETE\_CN

To stop the node, which deactivates all resources associated with it, use the following verb:

- TERM\_NODE

To define default parameters used by the node, or to query the definition of these parameters, use the following verbs:

- DEFINE\_DEFAULTS, QUERY\_DEFAULTS

To query the options and limits permitted by your CS/AIX license for the node, use the following verb:

- QUERY\_NODE\_LIMITS

## 3270 communications

If CS/AIX users will be using 3270 emulation to communicate with host systems, you need to define the communications link to the host. For more information, see [“Getting started” on page 6](#). The definition of the LS to the host must include the name of a local PU to own the LUs required for 3270 emulation and must have the *solicit\_sscp\_sessions* parameter set to AP\_YES.

You then need to define LUs that can be used for 3270 emulation. To do this, use the following verbs:

- DEFINE\_LU\_0\_TO\_3, DEFINE\_LU\_0\_TO\_3\_RANGE

To obtain information about the configuration or current status of LUs, use the following verb:

- QUERY\_LU\_0\_TO\_3

To obtain information about the PU that owns an LU, use the following verb:

- QUERY\_PU

To delete LUs when they are no longer required, use the following verbs:

- DELETE\_LU\_0\_TO\_3, DELETE\_LU\_0\_TO\_3\_RANGE

If you want to provide LU pools (groups of LUs that can be assigned to user sessions as required, rather than having an LU explicitly defined for each user session), use the following verbs to define a pool, to obtain information about the definition, or to delete a pool or remove LUs from it when no longer required:

- DEFINE\_LU\_POOL, QUERY\_LU\_POOL, DELETE\_LU\_POOL

## LUA communications

If applications running on CS/AIX will be using LUA to communicate with host programs, you need to define the communications link to the host. For more information, see [“Getting started” on page 6](#). The definition of the LS to the host must include the name of a local PU to own the LUs, and must have the *solicit\_sscp\_sessions* parameter set to AP\_YES.

You then need to define LUs that can be used for LUA. To define the LUs, use the following verbs:

- DEFINE\_LU\_0\_TO\_3 to define an individual LU or DEFINE\_LU\_0\_TO\_3\_RANGE to define multiple LUs with a single verb

To delete LUs when they are no longer required, use the following verbs:

- DELETE\_LU\_0\_TO\_3 to delete an individual LU or DELETE\_LU\_0\_TO\_3\_RANGE to delete multiple LUs with a single verb

To obtain information about the configuration or current status of LUs, use the following verb:

- QUERY\_LU\_0\_TO\_3

To obtain information about the PU that owns an LU, use the following verb:

- QUERY\_PU

If you want to provide LU pools (groups of LUs that can be assigned to applications as required, rather than having LUs explicitly defined for each application), use the following verbs to define a pool, to obtain information about the definition, or to delete a pool or remove LUs from it when no longer required:

- DEFINE\_LU\_POOL, QUERY\_LU\_POOL, DELETE\_LU\_POOL

If applications running on CS/AIX will be using LUA to communicate with applications on downstream computers, you need to define the LUs on the downstream computer and map these to the LUs on the CS/AIX node. To define the downstream LUs, use the following verbs:

- DEFINE\_DOWNSTREAM\_LU, DEFINE\_DOWNSTREAM\_LU\_RANGE, DEFINE\_DSPU\_TEMPLATE

To obtain information about the configuration or current status of downstream LUs or about the downstream PU that serves them, use the following verbs:

- QUERY\_DOWNSTREAM\_LU, QUERY\_DOWNSTREAM\_PU, QUERY\_DSPU\_TEMPLATE

## NOF verbs to manage specific CS/AIX functions

To delete downstream LUs when they are no longer required, use the following verbs:

- DELETE\_DOWNSTREAM\_LU, DELETE\_DOWNSTREAM\_LU\_RANGE, DELETE\_DSPU\_TEMPLATE

## APPC communications

If applications running on CS/AIX will be using APPC to communicate with applications running on host or peer computers, you need to define LUs that can be used for APPC.

APPC configuration in an APPN network is much simpler than in a pre-APPN SNA network. Many of the required components, and the interactions between them, can be defined or determined dynamically when sessions are started and do not need to be specified explicitly in the initial configuration.

Each node includes a default APPC local LU (the "control point LU"). An APPC application can use this LU, or you can define additional LUs so that different applications can use different LUs. To define the LUs, use the following verb:

- DEFINE\_LOCAL\_LU

To obtain information about the configuration or current status of LUs, including the control point LU, use the following verb:

- QUERY\_LOCAL\_LU

Because APPN can locate a partner LU dynamically when a local application needs to start a session to it, normally you do not need to define partner LUs. However, you may need to define partner LUs if you need to enforce the use of particular APPC features such as conversation security. To define a partner LU, use the following verb:

- DEFINE\_PARTNER\_LU

To obtain information about the current status of a partner LU or about its definition if it was explicitly defined, use the following verbs:

- QUERY\_PARTNER\_LU, QUERY\_PARTNER\_LU\_DEFINITION

If the local application communicates with its partner using one of the standard SNA-defined modes, you do not need to define a mode. However, you may want to define additional modes for applications that have particular requirements not covered by the standard modes. To define a mode, use the following verb:

- DEFINE\_MODE

To define or query the default mode, which specifies parameters that will be used for any unrecognized mode name, use the following verbs:

- DEFINE\_DEFAULTS, QUERY\_DEFAULTS

The class of service (COS) used for a mode is normally one of the standard SNA-defined classes of service. However, the node can be configured to support mapping each mode to a specific COS (the *mode\_to\_cos\_map\_supp* parameter on the DEFINE\_NODE verb). In this case, you may want to define additional COSs for applications that have particular requirements not covered by the standard COSs. To define a COS, use the following verb:

- DEFINE\_COS

To specify the default COS to which any unrecognized modes will be mapped, use the following verb:

- DEFINE\_MODE

To obtain information about the definition or current usage of a mode, about the COS used by a mode, or about the definition of a COS, use the following verbs:

- QUERY\_MODE\_DEFINITION, QUERY\_MODE, QUERY\_MODE\_TO\_COS\_MAPPING
- QUERY\_COS, QUERY\_COS\_NODE\_ROW, QUERY\_COS\_TG\_ROW

If the local and partner LUs use session-level security, you need to define the password used to establish a session between the local LU and partner LU. To define the password, check the current definition, or delete the password when it is no longer required, use the following verbs:

- DEFINE\_LU\_LU\_PASSWORD, QUERY\_LU\_LU\_PASSWORD, DELETE\_LU\_LU\_PASSWORD

To delete local LUs, partner LUs, modes, or COSs when they are no longer required, use the following verbs:

- DELETE\_LOCAL\_LU, DELETE\_PARTNER\_LU
- DELETE\_MODE, DELETE\_COS

CS/AIX negotiates session limits with the partner LU automatically when sessions are established. If you need to manage session limits between a local LU and its partner LU explicitly, use the following verbs:

- INITIALIZE\_SESSION\_LIMIT, CHANGE\_SESSION\_LIMIT, RESET\_SESSION\_LIMIT

To manage individual sessions and conversations, use the following verbs:

- QUERY\_SESSION, QUERY\_ISR\_SESSION, QUERY\_CONVERSATION
- ACTIVATE\_SESSION, DEACTIVATE\_SESSION, DEACTIVATE\_CONV\_GROUP

Normally you do not need to define CS/AIX invokable TPs if they are operator-started. If a TP is to be automatically started by CS/AIX when a remote TP allocates a conversation to it, if it is to be operator-started and a broadcast queued TP (which means that incoming conversation requests can be routed dynamically to the TP wherever it is running), or if it is to be operator-started and requires a specific Receive\_Allocate timeout value, you need to specify it in the CS/AIX invokable TP data file. For more information about this file, refer to the *IBM Communications Server for Data Center Deployment on AIX Administration Guide*.

In addition, if a TP (either operator-started or auto-started) needs to be restricted to particular values for conversation security, confirm synchronization, or conversation type (mapped or basic), or if you need to limit the number of instances of the TP that can be running at any time, you need to define the TP. Use the following verb:

- DEFINE\_TP

To obtain information about the definition of a TP, about its current usage, or about currently active invokable TPs, use the following verbs:

- QUERY\_TP\_DEFINITION, QUERY\_TP, QUERY\_AVAILABLE\_TP

To delete a defined TP when it is no longer required, use the following verb:

- DELETE\_TP

If the invokable TP requires conversation-level security, you need to define user IDs and passwords that remote TPs can use to access CS/AIX TPs. To define user IDs and passwords, check the current definitions, or delete user IDs and passwords when they are no longer required, use the following verbs:

- DEFINE\_USERID\_PASSWORD, QUERY\_USERID\_PASSWORD, DELETE\_USERID\_PASSWORD

To restrict the use of the TP to a specific list of authorized user IDs, check the current list of authorized user IDs, or delete a list of user IDs when it is no longer required, use the following verbs:

- DEFINE\_SECURITY\_ACCESS\_LIST, QUERY\_SECURITY\_ACCESS\_LIST,  
DELETE\_SECURITY\_ACCESS\_LIST

## **CPI-C communications**

CPI-C applications use the same resources as APPC applications; the information in [“APPC communications” on page 8](#), applies to CPI-C as well as to APPC.

In addition, you can set up side information entries for use by CPI-C applications; each entry defines a particular partner application and the information required to access it. The local CPI-C application can then identify its partner application simply by the name of a side information entry, instead of having to

## NOF verbs to manage specific CS/AIX functions

specify explicit partner LU and TP names, mode name, and conversation security requirements. To define side information entries, check the current definitions, or delete entries when they are no longer required, use the following verbs:

- DEFINE\_CPIC\_SIDE\_INFO, QUERY\_CPIC\_SIDE\_INFO, DELETE\_CPIC\_SIDE\_INFO

## Managing HPR RTP connections

To define tuning parameters to be used when setting up RTP connections, use the following verb:

- DEFINE\_RTP\_TUNING

To check the tuning parameters that are currently defined for use when setting up RTP connections, or to check details of currently active RTP connections, use the following verbs:

- QUERY\_RTP\_TUNING, QUERY\_RTP\_CONNECTION

## Managing SNA gateway

If the node supports SNA gateway (the *pu\_conc\_support* parameter on the DEFINE\_NODE verb), to enable type 0-3 LUs on downstream computers to communicate with host systems using LUs defined on the CS/AIX node, you must first define the following:

- A DLC, port, and LS from CS/AIX to the downstream computer. For information about defining these components, see [“Getting started” on page 6](#). The LS must be defined with the following parameters:

```
solicit_sscp_sessions = NO
dspu_services         = PU_CONCENTRATION

dspu_name = the name of the PU serving the LUs on the downstream computer
pu_name   = all zeros
```

- One or more type 0-3 LUs on the CS/AIX node (and optionally an LU pool containing these LUs) for communications with the host. For information about defining LUs and LU pools, see [“3270 communications” on page 7](#).

You then define the LUs on the downstream computer and map these to the LUs on the CS/AIX node. To define the downstream LUs, use the following verbs:

- DEFINE\_DOWNSTREAM\_LU, DEFINE\_DOWNSTREAM\_LU\_RANGE

To obtain information about the configuration or current status of downstream LUs or about the downstream PU that serves them, use the following verbs:

- QUERY\_DOWNSTREAM\_LU, QUERY\_DOWNSTREAM\_PU

To delete downstream LUs when they are no longer required, use the following verbs:

- DELETE\_DOWNSTREAM\_LU, DELETE\_DOWNSTREAM\_LU\_RANGE

## Managing DLUR

If the node supports DLUR (the *dlur\_support* parameter on the DEFINE\_NODE verb), and LUs on the CS/AIX node will be using DLUR to communicate with host systems, you need to define the PU on the local CS/AIX node that owns these LUs. This is not the same as defining a PU for LUs that communicate directly with the host (which is done using the DEFINE\_LS verb).

To define the PU, use the following verb:

- DEFINE\_INTERNAL\_PU

To obtain information about the PU, use the following verb:

- QUERY\_PU

To define and manage the LUs associated with this PU, see [“3270 communications” on page 7](#) or [“LUA communications” on page 7](#), earlier in this section.

To start the PU (to request an ACTPU from the host) in order to use the LUs or to stop it when applications are no longer using the LUs, use the following verbs:

- START\_INTERNAL\_PU, STOP\_INTERNAL\_PU

To delete the PU when it is no longer required, use the following verb:

- DELETE\_INTERNAL\_PU

If the local node is a network node, and LUs on downstream PUs will be using DLUR to communicate with host systems, you need to define the communications link to the downstream PU, as described in [“Getting started” on page 6](#). The LS definition must specify that the local node provides DLUR services to the downstream PU.

You do not need to define the downstream PUs; CS/AIX will obtain the necessary information dynamically when communications links are established. To obtain information about downstream PUs and LUs currently using DLUR, use the following verbs:

- QUERY\_DOWNSTREAM\_PU, QUERY\_DOWNSTREAM\_LU

To set up defaults to simplify DLUR configuration and reduce the information required on other DLUR verbs, use the following verb:

- DEFINE\_DLUR\_DEFAULTS

To obtain information about PUs and LUs currently using DLUR (either on the local node or on downstream PUs), or about the DLUR nodes they are using, use the following verbs:

- QUERY\_DLUR\_PU, QUERY\_DLUR\_LU, QUERY\_DLUR

## Managing TN server

If TN3270 users will be using the TN server feature on a CS/AIX node to communicate with host systems, you need to define the communications link to the host. For more information, see [“Getting started” on page 6](#). The definition of the LS to the host must include the name of a local PU to own the 3270 LUs and must have the *solicit\_sscp\_sessions* parameter set to AP\_YES.

You then need to define LUs that can be used for 3270 emulation and optionally group these LUs into LU pools. For more information about defining LUs and pools, see [“3270 communications” on page 7](#).

To define parameters that apply to all TN Server users, use the following verb:

- DEFINE\_TN3270\_DEFAULTS

If you are using Secure Sockets Layer (SSL) client authentication, and checking clients against a certificate revocation list on an external LDAP server, you need to configure details of how to access this server. In addition, if the client users are permitted to use the TN3270 Express Logon feature, so that their security certificate authorization replaces the standard user ID and password normally used for TN3270 security, you need to configure the host Digital Certificate Access Server (DCAS) used to manage this feature. Use the following verbs:

- DEFINE\_TN3270\_SSL\_LDAP
- DEFINE\_TN3270\_EXPRESS\_LOGON

To define the TN3270 users that can access TN server and assign them to CS/AIX 3270 LUs, use the following verb:

- DEFINE\_TN3270\_ACCESS

To define the association between TN3270 display and printer LUs, so that a TN3270E client can connect to the printer LU that is associated with a display LU without knowing the name of the printer LU, use the following verb:

- DEFINE\_TN3270\_ASSOCIATION

To allow TN3270 clients to select a TN Server using SLP, use the following verb:

- DEFINE\_TN3270\_SLP

## NOF verbs to manage specific CS/AIX functions

To obtain information about the configuration of TN Server and TN3270 users, use the following verbs:

- QUERY\_TN3270\_ACCESS\_DEF, QUERY\_TN3270\_ASSOCIATION, QUERY\_TN3270\_DEFAULTS, QUERY\_TN3270\_SSL\_LDAP, QUERY\_TN3270\_EXPRESS\_LOGON, QUERY\_TN3270\_SLP

To delete TN3270 users so that they can no longer use TN server for 3270 emulation, or to delete LU association information, use the following verbs:

- DELETE\_TN3270\_ACCESS, DELETE\_TN3270\_ASSOCIATION

## Managing TN Redirector

If Telnet users will be using the TN Redirector feature on a CS/AIX node to communicate with host systems, you need to define these users and how they will access the host.

To define the TN3270 users that can access TN Redirector, use the following verb:

- DEFINE\_TN\_REDIRECT

If you are using Secure Sockets Layer (SSL) client authentication, and checking clients against a certificate revocation list on an external LDAP server, you need to configure details of how to access this server. In addition, if the client users are permitted to use the TN3270 Express Logon feature, so that their security certificate authorization replaces the standard user ID and password normally used for TN3270 security, you need to configure the host Digital Certificate Access Server (DCAS) used to manage this feature. Use the following verbs:

- DEFINE\_TN3270\_SSL\_LDAP

To obtain information about the configuration of TN Redirector and TN Redirector users, use the following verbs:

- QUERY\_TN\_REDIRECT\_DEF, QUERY\_TN3270\_SSL\_LDAP

To delete TN Redirector users so that they can no longer use TN Redirector to access the host, use the following verb:

- DELETE\_TN\_REDIRECT

## Managing SNA management services functions

If applications running on CS/AIX will be using the MS API to communicate with remote MS applications, you do not need to define any resources for this explicitly, because the node will locate the appropriate remote applications as required. However, you can define the resources explicitly if you want to specify a particular remote application to use.

To specify a default PU for use by NMVT-level applications (so that they access the NetView program at a specific host), use the following verb:

- DEFINE\_DEFAULT\_PU

To specify a focal point application for use by MDS-level applications (instead of enabling the remote focal point application to determine which nodes it manages), use the following verb:

- DEFINE\_FOCAL\_POINT

To obtain information about the focal point currently in use, or to delete a previously defined focal point, use the following verbs:

- QUERY\_FOCAL\_POINT, DELETE\_FOCAL\_POINT

To obtain information about active applications (NMVT-level or MDS-level) using MS functions, use the following verbs:

- QUERY\_NMVT\_APPLICATION, QUERY\_MDS\_APPLICATION

To obtain information about outstanding requests from MDS-level applications, or to obtain statistical information about previous requests, use the following verbs:



- QUERY\_ACTIVE\_TRANSACTION, QUERY\_MDS\_STATISTICS

## Managing access to the CS/AIX system from the host NetView program

If you want to enable operators at the host NetView console to issue commands on the CS/AIX computer using either the Service Point Command Facility (SPCF) or the UNIX Command Facility (UCF), you need to define the access permissions for these operators.

To define these permissions and enable NetView operators to access SPCF or UCF or both, use the following verb:

- DEFINE\_RCF\_ACCESS

To check the permissions currently defined, use the following verb:

- QUERY\_RCF\_ACCESS

To prevent operators from using either SPCF or UCF, use the following verb:

- DELETE\_RCF\_ACCESS

To remove access to one function but leave the other available, use the following verb:

- DEFINE\_RCF\_ACCESS

## Managing diagnostics settings

The CS/AIX default setting for log messages is to log problem and exception messages but not audit messages, and to use local logging (messages from each server are written to a file on that server) rather than central logging (messages from all servers are sent to a central log file on the controller server). Succinct logging is used (that is, logging of header parameters and message text, but not full details of cause and action for each message). The error log file, used for problem and exception messages, is `/var/sna/sna.err`; the audit log file, used for audit messages if these are enabled, is `/var/sna/sna.aud`. Each of these files is backed up and reset when the file size reaches 10 megabytes. The default settings for succinct logging, exception and audit logging, file names, and file sizes can all be overridden using NOF verbs, as described in the following information.

The verbs to manage central logging and global logging options apply to clients as well as to servers. However, other diagnostics settings on Windows clients are controlled by options in the Windows Registry, and not by NOF verbs. For more information, refer to the *IBM Communications Server for Data Center Deployment on AIX Administration Guide*.

CS/AIX also maintains a usage log file `/var/sna/sna.usage`, which is used to record information about the current and peak usage of CS/AIX resources. This file is backed up and reset in the same way as the error and audit log files, and the file name and file size can be specified in the same way.

To specify whether central logging is enabled, use the following verb:

- SET\_CENTRAL\_LOGGING

To specify whether exception messages or audit messages or both are logged, or to specify whether succinct logging or full logging is to be used, either to establish global default settings for all servers or to override the defaults for a particular server, use the following verbs:

- SET\_GLOBAL\_LOG\_TYPE, SET\_LOG\_TYPE

To change the file names or directories used for log messages or to change the size at which files are backed up and reset, use the following verb:

- SET\_LOG\_FILE

To check which server is currently defined as the central logger or to check whether central logging is enabled, use the following verbs:

- QUERY\_CENTRAL\_LOGGER, QUERY\_CENTRAL\_LOGGING

## NOF verbs to manage specific CS/AIX functions

To check the types of messages being recorded or to check whether succinct logging or full logging is being used, either globally or on a particular server, use the following verbs:

- QUERY\_GLOBAL\_LOG\_TYPE, QUERY\_LOG\_TYPE

To check the file, file size, or directory being used for a particular log type, use the following verb:

- QUERY\_LOG\_FILE

If you want to activate tracing to diagnose problems with connectivity components on a particular CS/AIX node or to deactivate it after collecting the required data, use the following verbs:

- ADD\_DLC\_TRACE, REMOVE\_DLC\_TRACE

If you want to activate tracing to diagnose problems with other CS/AIX kernel components or to deactivate it after collecting the required data, use the following verb:

- SET\_TRACE\_TYPE

If you want to activate tracing to diagnose problems with communications between clients and servers across the CS/AIX LAN or to deactivate it after collecting the required data, use the following verb:

- SET\_CS\_TRACE

If you want to activate tracing to diagnose problems with the CS/AIX TN server feature or to deactivate it after collecting the required data, use the following verbs:

- SET\_TN\_SERVER\_TRACE
- SET\_TN3270\_SLP\_TRACE

The default files used for trace data are as follows:

- /var/sna/sna1.trc and /var/sna/sna2.trc for tracing on a particular computer
- /var/sna/snacs1.trc and /var/sna/snacs2.trc for LAN tracing
- /var/sna/snatnsv1.trc and /var/sna/snatnsv2.trc for TN server tracing

If you want to use different files or directories for either of these trace types or to send all tracing of a particular type to one file instead of two files, use the following verb:

- SET\_TRACE\_FILE

To check the current settings for a particular trace type or to check the files used for a particular trace type, use the following verbs:

- QUERY\_DLC\_TRACE, QUERY\_TRACE\_TYPE, QUERY\_CS\_TRACE, QUERY\_TN\_SERVER\_TRACE, QUERY\_TRACE\_FILE, QUERY\_TN3270\_SLP\_TRACE

## Managing directory entries

If the local node is a LEN node, you need to set up entries in the local node's directory to identify the adjacent nodes that CS/AIX will communicate with and the LUs associated with these nodes. If a particular node contains a range of LUs with similar names, you can set up wildcard entries in the directory to indicate that all LUs in the range are on the specified node.

To define a node and the LUs associated with it, use the following verb:

- DEFINE\_ADJACENT\_LEN\_NODE

To obtain information about a specific node or LU entry in the database (however, this verb cannot be used to return information about wildcard entries), use the following verb:

- QUERY\_DIRECTORY\_ENTRY

To obtain information about a specific LU entry or wildcard entry in the database, use the following verb:

- QUERY\_DIRECTORY\_LU

To obtain statistical information about directory entries, use the following verb:

- QUERY\_DIRECTORY\_STATS

To delete a node and the LUs associated with it or to delete LUs from a node entry, use the following verb:

- DELETE\_ADJACENT\_LEN\_NODE

If the local node is an end node or network node communicating with a LEN node, or if the local node is the network node serving a LEN node, you need to set up directory entries for the LEN node and its LUs, using the verbs described above. For communications with other node types, you do not need to set up directory entries because the node will locate these resources dynamically as required (and add them to the directory so that they can be used again).

However, you may want to set up entries for particular nodes or LUs so that the local node can communicate with these resources without having to search for them. Because setting up entries for particular nodes or LUs overrides the normal APPN resource location process, you can have problems at this node or at other nodes in the network if the definitions are not correct. Do not define explicit entries for resources at other nodes unless you are sure that the definitions are correct.

To define an individual node, LU, or wildcard entry for a range of LUs, use the following verb:

- DEFINE\_DIRECTORY\_ENTRY

To delete an individual node, LU, or wildcard entry from the directory, use the following verb:

- DELETE\_DIRECTORY\_ENTRY

Delete only directory entries that were explicitly defined using the verbs described previously (these entries return an entry type of HOME on the QUERY\_DIRECTORY\_ENTRY verb). Do not use this verb to delete cached entries (entries that have been set up dynamically as a result of network searches).

## Querying the network topology

To obtain information (on a network node) about adjacent network nodes, use the following verb:

- QUERY\_ADJACENT\_NN

To obtain information about the TGs to adjacent network nodes, use the following verb:

- QUERY\_LOCAL\_TOPOLOGY

To obtain information (on a network node) about network nodes and virtual routing nodes (VRNs) in the network, or about the TGs to these nodes, use the following verbs:

- QUERY\_NN\_TOPOLOGY\_NODE, QUERY\_NN\_TOPOLOGY\_TG

To obtain statistical information (on a network node) about the use of entries in the local node's topology database, use the following verb:

- QUERY\_NN\_TOPOLOGY\_STATS

## Checking the communications path to a remote LU

To check that a particular target LU can be accessed (that the node owning the LU is active and that there is a communications path to the LU), use the following verb:

- APING

## Managing servers and clients on the CS/AIX LAN

To obtain a list of servers (nodes) on the CS/AIX LAN, use the following verb:

- QUERY\_NODE\_ALL

To obtain detailed information about a particular node, use the following verb:

- QUERY\_NODE

## NOF indications

To find out which servers are acting as the controlling configuration file server and backup servers, use the following verb:

- QUERY\_SNA\_NET

To add new backup servers to the list or to remove existing servers from the list so that they can no longer act as controller servers, use the following verbs:

- ADD\_BACKUP, DELETE\_BACKUP

To obtain a list of Remote API Clients (on AIX, Linux or Windows) using a particular server on the CS/AIX LAN, use the following verb:

- QUERY\_RAPI\_CLIENTS

## Managing configuration file header information

To add a descriptive comment string to the domain configuration file, use the following verb:

- DEFINE\_DOMAIN\_CONFIG\_FILE

To obtain information about the CS/AIX version number for which the domain configuration file was created or about the comment string stored in it, use the following verb:

- QUERY\_DOMAIN\_CONFIG\_FILE

There are no corresponding verbs for the node configuration file because the header information in the node configuration file is for CS/AIX internal use only; do not attempt to modify it.

## Managing AIX resource usage

To set a limit on the amount of kernel memory that CS/AIX can use for internal data structures or to specify the maximum amount of memory available for STREAMS buffers, use the following verbs:

- SET\_KERNEL\_MEMORY\_LIMIT, SET\_BUFFER\_AVAILABILITY

To obtain information about the current limits and usage, use the following verbs:

- QUERY\_KERNEL\_MEMORY\_LIMIT, QUERY\_BUFFER\_AVAILABILITY

## NOF Indications

---

A NOF application can use the REGISTER\_INDICATION\_SINK verb to request information about changes to the CS/AIX configuration or to the status of its resources. CS/AIX then sends an indication message to the application each time a change occurs.

For more details of the indications that an application can request, see [Chapter 4, “NOF Indications,” on page 599](#).

Except for CONFIG\_INDICATION, NOF\_STATUS\_INDICATION, and SNA\_NET\_INDICATION, each indication is returned when a resource of the specified type changes its status. For example, if the application registers for DLC indications, CS/AIX sends a DLC\_INDICATION message to the application each time a DLC becomes active or inactive.

An indication returns summary information about the change that has occurred. If necessary, the application can then issue the appropriate QUERY\_\* verb to obtain more detailed information.

If the local node is short of resources, it can temporarily suppress indications and not send them to applications. When the resource shortage condition clears, and the local node subsequently generates an indication of a type that it has previously suppressed, it then sets a parameter on the indication to inform the application that one or more previous indications of this type have been lost. The application should then issue QUERY\_\* verbs for the appropriate resource type to determine the current state of resources.

For more information about registering to receive indications, see [“REGISTER\\_INDICATION\\_SINK” on page 553](#). For more information about individual indications, see [Chapter 4, “NOF Indications,” on page 599](#).

## Configuration indications

An application can register to receive information about changes to the configuration of a particular target (the domain configuration file, a running node, or an inactive node). This enables it to keep track of changes that can be made by other NOF applications or by the administration programs. To do this, the application registers as for other indications, specifying `CONFIG_INDICATION` as the requested indication type.

No specific VCB structure is associated with this indication type. Instead, when a change to the configuration occurs, CS/AIX indicates this change to the application by sending a copy of the completed VCB from the NOF verb that made the change.

For more information about configuration indications, see [“CONFIG\\_INDICATION” on page 599](#).

## SNA network file indications

An application can register to receive information about changes to the SNA network file `sna.net` on the controller server. This enables the application to keep track of changes to this file that can be made by other NOF applications or by the command-line administration program. To do this, the application registers as for other indications, specifying `SNA_NET_INDICATION` as the requested indication type.

Two VCB structures are associated with this indication type:

- `ADD_BACKUP` (indicating that a backup server has been added to the end of the file)
- `DELETE_BACKUP` (indicating that an unused backup server has been removed from the file)

Registering with a type of `SNA_NET_INDICATION` will return an `ADD_BACKUP` indication when a backup server is added or a `DELETE_BACKUP` indication when a server is deleted; the application does not need to register separately for each of these indications. In each case, the format of the indication is a copy of the completed VCB from the NOF verb that made the change.

For more information about SNA network file indications, see [“SNA\\_NET\\_INDICATION” on page 648](#).

## NOF status indications

CS/AIX sends a NOF status indication to a registered NOF application when the application can no longer access its target node or file (because the CS/AIX software on the target computer has been stopped or because the communications path to this computer has been lost). If the application is registered to receive indications from the controlling configuration file, this indication is also returned if another server takes over as controller (and therefore the target file is no longer the controlling configuration file).

The application does not need to register explicitly to receive this indication; CS/AIX returns it to any application that has registered for any type of NOF indications on the appropriate target. The indication is returned on the callback routine that the application supplied to the `REGISTER_INDICATION_SINK` verb (or to the first `REGISTER_INDICATION_SINK` verb, if the application has issued more than one).

After the application receives an indication that the target has failed, all subsequent verbs using the relevant target handle will be rejected, except for `DISCONNECT_NODE` or `CLOSE_FILE` (to free the target handle). In addition, any registrations for indications on this target handle will be lost; in order to continue receiving indications when the target becomes available, the application must connect again to the target and register again for the required indications.

For more information about NOF status indications, see [Chapter 4, “NOF Indications,” on page 599](#).



## Chapter 2. Writing NOF applications

This chapter describes the following:

- Client/Server considerations

UNIX

- AIX or Linux considerations
  - NOF API entry points for AIX
  - Compiling and linking the NOF application

WINDOWS

- Windows considerations
  - NOF API entry points for Windows
  - Compiling and linking the NOF application

- Writing portable applications
- Target (node or file) for NOF verbs, and how they interact with the target
- Ordering and dependencies between NOF verbs
- NOF restrictions based on node configuration
- How to request single or multiple data entries with QUERY\_\* verbs

### Client/Server considerations

In a client/server system, you can use any NOF verbs in an application running on a server. Applications running on Remote API Clients can use NOF verbs as follows.

- They can use QUERY\_\* verbs to query configuration or status information.
- They can use verbs to activate sessions or initialize session limits, or to manage logging and Client/Server tracing. The NOF application must run with the userid `root`, or with a userid that is a member of the `sys` group (AIX) or `sna` group (Linux), in order to use these commands.
- They cannot use other verbs to modify the configuration or to start or stop resources. If your NOF application needs to modify the configuration or to start or stop resources, you must write it for AIX and run it on a server.

### AIX or Linux considerations

UNIX

This section describes operating system issues that you need to consider when writing NOF applications for use in the AIX or Linux environment.

#### NOF API entry points for AIX or Linux

An application accesses the NOF API using the following entry point function calls:

### **nof**

Issues a NOF verb synchronously. CS/AIX does not return control to the application until verb processing has finished. All NOF verbs except REGISTER\_INDICATION\_SINK and UNREGISTER\_INDICATION\_SINK can be issued through this entry point.

An application can use this entry point only if the application can suspend while waiting for CS/AIX to completely process a verb.

### **nof\_async**

Issues a NOF verb asynchronously. CS/AIX returns control to the application immediately, with a returned value indicating whether verb processing is still in progress or has completed. If the returned value indicates that verb processing is still in progress, CS/AIX uses an application-supplied callback routine to return the results of the verb processing. In cases when CS/AIX is able to completely process the request, the callback routine will not be invoked.

All NOF verbs can be issued through this entry point. The REGISTER\_INDICATION\_SINK and UNREGISTER\_INDICATION\_SINK verbs must be issued through this entry point.

An application must use this entry point if either of the following conditions is true:

- The application needs to receive NOF indications.
- The application cannot suspend while waiting for CS/AIX to completely process a verb.

### **nof\_async callback routine**

When using the asynchronous NOF API entry point, the application must supply a pointer to a callback routine. CS/AIX uses this callback routine both for completion of a verb and also for returning NOF data and status indications.

The `nof` and `nof_async` entry points are defined in the NOF header file `nof_c.h`. Parameter types such as `AP_UINT32`, used in these entry points and in the NOF VCBs, are defined in the common header file `values_c.h`, which is included by the NOF header file `nof_c.h`. Both of these files are stored in `/usr/include/sna` (AIX) or `/opt/ibm/sna/include` (Linux).

## **Synchronous entry point: nof**

An application uses the `nof` entry point to issue a NOF verb synchronously. CS/AIX does not return control to the application until verb processing has finished.

### **Function call**

```
void nof (
    AP_UINT32    target_handle,
    void *       nofvcb
);
```

### **Supplied parameters**

An application supplies the following parameters when it uses the `nof` entry point:

#### **target\_handle**

An identifier that the application uses to identify the target CS/AIX node or file. This parameter is supplied in one of the following ways:

- For the following verbs, this parameter is not supplied; set it to 0 (zero). If the verb completes successfully, CS/AIX returns the target handle as one of the VCB parameters. The application then uses the target handle for subsequent verbs.
  - CONNECT\_NODE (to access a running node, or to access the node on a server where the CS/AIX software is started but the node is not yet started)
  - OPEN\_FILE (to access the domain configuration file or the SNA network data file)
- For the following verbs, the application supplies a null value:
  - QUERY\_NODE\_ALL (to obtain a list of running nodes)



- QUERY\_CENTRAL\_LOGGER
- For all other NOF verbs, the application supplies the value that was returned on the CONNECT\_NODE or OPEN\_FILE verb.

**nofvcb**

Pointer to a Verb Control Block (VCB) that contains the parameters for the verb being issued. The VCB structure for each verb is described in Chapter 3, “NOF API Verbs,” on page 35. These structures are defined in the NOF API header file `/usr/include/sna/nof_c.h` (AIX) or `/opt/ibm/sna/include/nof_c.h` (Linux).

**Note:** The NOF VCBs contain many parameters marked as "reserved"; some of these are used internally by the CS/AIX software, and others are not used in this version but may be used in future versions. Your application must not attempt to access any of these reserved parameters; instead, it must set the entire contents of the VCB to zero to ensure that all of these parameters are zero, before it sets other parameters that are used by the verb. This ensures that CS/AIX will not misinterpret any of its internally-used parameters, and also that your application will continue to work with future CS/AIX versions in which these parameters may be used to provide new functions.

To set the VCB contents to zero, use `memset`:

```
memset(nofvcb, 0, sizeof(nofvcb));
```

**Returned values**

The `nof` entry point does not have a return value. When the call returns, the application should examine the return code in the VCB to determine whether the verb completed successfully and to determine parameters it needs for further verbs. In particular, when the `CONNECT_NODE` or `OPEN_FILE` verb completes successfully, the VCB contains the *target\_handle* that the application should use when issuing subsequent verbs.

**Using the synchronous entry point**

Only one synchronous verb can be outstanding at any time for each target handle. A synchronous verb fails with the primary return code `AP_STATE_CHECK` and secondary return code `AP_SYNC_PENDING` if another synchronous verb for the same target handle is in progress.

**Asynchronous entry point: nof\_async**

An application uses `nof_async` to issue a NOF verb asynchronously. The application also supplies a pointer to a callback routine. CS/AIX returns control to the application immediately with a returned value that indicates whether verb processing is still in progress or has completed. In most cases, verb processing is still in progress when control returns to the application. In these cases, CS/AIX uses the application-supplied callback routine to return the results of the verb processing at a later time. In some cases, verb processing is complete when CS/AIX returns control to the application, so CS/AIX does not use the application's callback routine.

**Function call**

```
AP_UINT16 nof_async(
    AP_UINT32      target_handle,
    void *         nofvcb,
    NOF_CALLBACK (*comp_proc),
    AP_CORR       corr
);

typedef void (*NOF_CALLBACK) (
    AP_UINT32      target_handle,
    void *         nofvcb,
    AP_CORR       corr,
    AP_UINT32     indic_length
);

typedef union ap_corr {
    void *         corr_p;
    AP_UINT32     corr_l;
};
```

```

        AP_INT32      corr_i;
    } AP_CORR;

```

For more information about the parameters in the NOF\_CALLBACK structure, see [“The callback routine specified on the nof\\_async entry point”](#) on page 23.

### Supplied parameters

An application supplies the following parameters when it uses the nof\_async entry point:

#### target\_handle

This parameter is supplied in one of the following ways:

- For the following verbs, this parameter is not used; set it to 0 (zero). If the verb completes successfully, CS/AIX returns the target handle as one of the VCB parameters. The application then uses the target handle for subsequent verbs.
  - CONNECT\_NODE (to access a running node, or to access the node on a server where the CS/AIX software is started but the node is not yet started)
  - OPEN\_FILE (to access the domain configuration file or the SNA network data file)
- For the following verbs, the application supplies a null value:
  - QUERY\_NODE\_ALL (to obtain a list of running nodes)
  - QUERY\_CENTRAL\_LOGGER
- For all other NOF verbs, the application supplies the value that was returned on the CONNECT\_NODE or OPEN\_FILE verb.

#### nofvcb

Pointer to a Verb Control Block (VCB) that contains the parameters for the verb being issued. The VCB structure for each verb is described in [Chapter 3, “NOF API Verbs,”](#) on page 35. These structures are defined in the NOF API header file /usr/include/sna/nof\_c.h (AIX) or /opt/ibm/sna/include/nof\_c.h (Linux).

**Note:** The NOF VCBs contain many parameters marked as "reserved"; some of these are used internally by the CS/AIX software, and others are not used in this version but may be used in future versions. Your application must not attempt to access any of these reserved parameters; instead, it must set the entire contents of the VCB to zero to ensure that all of these parameters are zero, before it sets other parameters that are used by the verb. This ensures that CS/AIX will not misinterpret any of its internally-used parameters, and also that your application will continue to work with future CS/AIX versions in which these parameters may be used to provide new functions.

To set the VCB contents to zero, use memset:

```
memset(nofvcb, 0, sizeof(nofvcb));
```

#### comp\_proc

The callback routine that CS/AIX will call when the verb completes. For more information about the requirements for a callback routine, see [“The callback routine specified on the nof\\_async entry point”](#) on page 23.

#### corr

An optional correlator for use by the application. This parameter is defined as a C union so that the application can specify any of three different parameter types: pointer, 32-bit integer, or 16-bit integer.

CS/AIX does not use this value, but passes it as a parameter to the callback routine when the verb completes. This value enables the application to correlate the returned information with its other processing.

### Returned values

The asynchronous entry point returns one of the following values:

**AP\_COMPLETED**

The verb has already completed. The application can examine the parameters in the VCB to determine whether the verb completed successfully. CS/AIX does not call the supplied callback routine for this verb.

**AP\_IN\_PROGRESS**

The verb has not yet completed. The application can continue with other processing, including issuing other NOF verbs, provided that they do not depend on the completion of the current verb. However, the application should not attempt to examine or modify the parameters in the VCB supplied to this verb.

CS/AIX calls the supplied callback routine to indicate when the verb processing completes. The application can then examine the VCB parameters.

**Using the asynchronous entry point**

When using the asynchronous entry point, note the following:

- If an application specifies a null pointer in the *comp\_proc* parameter, the verb will complete synchronously (as though the application issued the verb using the synchronous entry point).
- If the call to *nof\_async* is made from within an application callback, specifying a null pointer in the *comp\_proc* parameter is not permitted. In such cases, CS/AIX rejects the verb with a primary return code value of *AP\_PARAMETER\_CHECK* and a secondary return code value of *AP\_SYNC\_NOT\_ALLOWED*.
- The application must not attempt to use or modify any parameters in the VCB until the callback routine has been called.
- Multiple verbs do not necessarily complete in the order in which they were issued. In particular, if an application issues an asynchronous verb followed by a synchronous verb, the completion of the synchronous verb does not guarantee that the asynchronous verb has already completed.

**The callback routine specified on the *nof\_async* entry point**

When using the asynchronous NOF API entry point, the application must supply a pointer to a callback routine. CS/AIX uses this callback routine both for completion of a verb and also for returning NOF indications. (The *REGISTER\_INDICATION\_SINK* verb is also issued as an asynchronous verb that specifies a callback routine; the callback is called each time the indication is received. For other NOF verbs, an indication is received when the verb completes.) The application must examine the *opcode* parameter in the VCB to determine which event is contained in the callback routine.

This section describes how CS/AIX uses the callback routine and the functions that the callback routine must perform.

**Callback function**

```
NOF_CALLBACK (*comp_proc);
typedef void (*NOF_CALLBACK) (
    AP_UINT32      target_handle,
    void *         nofvcb,
    AP_CORR        corr,
    AP_UINT32      indic_length
);
typedef union ap_corr {
    void *         corr_p;
    AP_UINT32      corr_l;
    AP_INT32       corr_i;
} AP_CORR;
```

**Supplied parameters**

CS/AIX calls the callback routine with the following parameters:

***target\_handle***

For NOF indications, CS/AIX passes the target handle that was supplied with the *REGISTER\_INDICATION\_SINK* verb. For completion of verbs, this parameter is undefined.

### ***nofvcb***

One of the following:

- For NOF indications, a pointer to a VCB supplied by CS/AIX.
- For completion of verbs, a pointer to the VCB supplied by the application. The VCB now includes the returned parameters set by CS/AIX.

### ***corr***

The correlator value supplied by the application. This value enables the application to correlate the returned information with its other processing.

The callback routine need not use all of these parameters (except as described in [“Using the callback routine for indications”](#) on page 24). The callback routine can perform all the necessary processing on the returned parameters, or it can simply set a variable to inform the NOF application that the verb has completed.

## **Returned values**

The callback function does not return any values.

## **Using the callback routine for indications**

Although the application allocates the VCBs for NOF verbs, CS/AIX allocates the VCBs for indications. Therefore, the application has access to the VCB information only from within the callback routine; the VCB pointer that CS/AIX supplies to the callback routine is not valid outside the callback routine. The application must either complete all the required processing from within the callback routine, or make a copy of any VCB data that it needs to use outside this routine.

## **Scope of target handle**

Each application that needs to use NOF must issue the CONNECT\_NODE verb to obtain its own handle. No two NOF applications can use the same NOF target handle.

In particular, if the application that issued CONNECT\_NODE later forks to create a child process, the child process cannot issue any NOF verbs that use the target handle obtained by the parent process. However, the child process can issue another CONNECT\_NODE to obtain its own target handle.

# **Compiling and linking the NOF application**

## **AIX applications**

To compile and link 32-bit applications, use the following options:

```
-bimport:/usr/lib/sna/nof_r.exp -I /usr/include/sna
```

To compile and link 64-bit applications, use the following options:

```
-bimport:/usr/lib/sna/nof_r64_5.exp -I /usr/include/sna
```

## **Linux applications**

Before compiling and linking a NOF application, specify the directory where shared libraries are stored, so that the application can find them at run time. To do this, set the environment variable LD\_RUN\_PATH to /opt/ibm/sna/lib, or to /opt/ibm/sna/lib64 if you are compiling a 64-bit application.

To compile and link 32-bit applications, use the following options:

```
-I /opt/ibm/sna/include -L /opt/ibm/sna/lib -lnof -lsna_r -lpthread -lpLiS
```

To compile and link 64-bit applications, use the following options:

```
-I /opt/ibm/sna/include -L /opt/ibm/sna/lib64 -lnof -lsna_r -lpthread -lpLiS
```

The option `-lpLiS` is required only if you will be running the application on a CS/AIX server; you do not need to use it if you are building the application on an IBM Remote API Client and it will run only on the client. As an alternative to using this option, you can set the environment variable `LD_PRELOAD` to `/usr/lib/libpLiS.so` before compiling and linking the application.

## Windows considerations



This section describes operating system issues that you need to consider when writing NOF applications for use on Windows clients.

Note that applications running on Remote API Clients on Windows can use NOF QUERY\_\* verbs to query configuration or status information, but cannot use other verbs to modify the configuration or to start or stop resources. If your NOF application needs to modify the configuration or to start or stop resources, you must write it for AIX and run it on a server.

### NOF API entry points for Windows

A Windows NOF application accesses the NOF API using the following entry point function calls:

#### **nof**

Issues a NOF verb synchronously. The Remote API does not return control to the application until verb processing has finished.

An application can use this entry point only if the application can suspend while waiting for the Remote API to completely process a verb.

#### **nof\_async**

Issues a NOF verb asynchronously. The Remote API returns control to the application immediately, with a returned value indicating whether verb processing is still in progress or has completed. If the returned value indicates that verb processing is still in progress, it will later complete asynchronously; the Remote API indicates the completion by signaling an event handle supplied by the application. In cases when the Remote API is able to completely process the request, the event handle will not be signaled.

An application must use this entry point if it cannot suspend while waiting for the Remote API to completely process a verb.

The `nof` and `nof_async` entry points are defined in the NOF header file `winnof.h`; this file is installed in the subdirectory in the subdirectory `\sdk` for 32-bit applications, or `\sdk64` for 64-bit applications, within the directory where you installed the Windows Client software. Parameter types such as `AP_UINT32`, used in these entry points and in the NOF VCBs, are defined in the common header file `values_c.h`, which is installed in the same directory and is included by the NOF header file `winnof.h`.

### Synchronous entry point: **nof**

An application uses the `nof` entry point to issue a NOF verb synchronously. The Remote API does not return control to the application until verb processing has finished.

#### **Function call**

```
void WINAPI nof (
    AP_UINT32      target_handle,
    void *         nofvcb
);
```

### ***Supplied parameters***

An application supplies the following parameters when it uses the `nof` entry point:

#### ***target\_handle***

An identifier that the application uses to identify the target CS/AIX node or file. This parameter is supplied in one of the following ways:

- For the following verbs, this parameter is not supplied; set it to 0 (zero). If the verb completes successfully, the Remote API returns the target handle as one of the VCB parameters. The application then uses the target handle for subsequent verbs.
  - CONNECT\_NODE (to access a running node, or to access the node on a server where the CS/AIX software is started but the node is not yet started)
  - OPEN\_FILE (to access the domain configuration file or the SNA network data file)
- For the following verbs, the application supplies a null value:
  - QUERY\_NODE\_ALL (to obtain a list of running nodes)
  - QUERY\_CENTRAL\_LOGGER
- For all other NOF verbs, the application supplies the value that was returned on the CONNECT\_NODE or OPEN\_FILE verb.

#### ***nofvcb***

Pointer to a Verb Control Block (VCB) that contains the parameters for the verb being issued. The VCB structure for each verb is described in Chapter 3, “NOF API Verbs,” on page 35. These structures are defined in the NOF API header file `nof_c.h`.

**Note:** The NOF VCBs contain many parameters marked as "reserved"; some of these are used internally by the CS/AIX software, and others are not used in this version but may be used in future versions. Your application must not attempt to access any of these reserved parameters; instead, it must set the entire contents of the VCB to zero to ensure that all of these parameters are zero, before it sets other parameters that are used by the verb. This ensures that CS/AIX will not misinterpret any of its internally-used parameters, and also that your application will continue to work with future CS/AIX versions in which these parameters may be used to provide new functions.

To set the VCB contents to zero, use `memset`:

```
memset(nofvcb, 0, sizeof(nofvcb));
```

### ***Returned values***

The `nof` entry point does not have a return value. When the call returns, the application should examine the return code in the VCB to determine whether the verb completed successfully and to determine parameters it needs for further verbs. In particular, when the CONNECT\_NODE or OPEN\_FILE verb completes successfully, the VCB contains the *target\_handle* that the application should use when issuing subsequent verbs.

### ***Using the synchronous entry point***

Only one synchronous verb can be outstanding at any time for each target handle. A synchronous verb fails with the primary return code `AP_STATE_CHECK` and secondary return code `AP_SYNC_PENDING` if another synchronous verb for the same target handle is in progress.

### ***Asynchronous entry point: nof\_async***

An application uses `nof_async` to issue a NOF verb asynchronously. The application also supplies a pointer to a callback routine. The Remote API returns control to the application immediately with a returned value that indicates whether verb processing is still in progress or has completed. In most cases, verb processing is still in progress when control returns to the application. In these cases, the Remote API uses the application-supplied callback routine to return the results of the verb processing at a later time. In some cases, verb processing is complete when the Remote API returns control to the application, so the Remote API does not use the application's callback routine.

## Function call

```

AP_UINT16 WINAPI nof_async(
    AP_UINT32      target_handle,
    void *         nofvcb,
    NOF_CALLBACK  (*comp_proc),
    AP_CORR       corr
);

typedef void (*NOF_CALLBACK) (
    AP_UINT32      target_handle,
    void *         nofvcb,
    AP_CORR       corr,
    AP_UINT32     indic_length
);

typedef union ap_corr {
    void *         corr_p;
    AP_UINT32     corr_l;
    AP_INT32      corr_i;
} AP_CORR;

```

For more information about the parameters in the NOF\_CALLBACK structure, see [“The callback routine specified on the nof\\_async entry point”](#) on page 28.

## Supplied parameters

An application supplies the following parameters when it uses the nof\_async entry point:

### target\_handle

This parameter is supplied in one of the following ways:

- For the following verbs, this parameter is not used; set it to 0 (zero). If the verb completes successfully, the Remote API returns the target handle as one of the VCB parameters. The application then uses the target handle for subsequent verbs.
  - CONNECT\_NODE (to access a running node, or to access the node on a server where the CS/AIX software is started but the node is not yet started)
  - OPEN\_FILE (to access the domain configuration file or the SNA network data file)
- For the following verbs, the application supplies a null value:
  - QUERY\_NODE\_ALL (to obtain a list of running nodes)
  - QUERY\_CENTRAL\_LOGGER
- For all other NOF verbs, the application supplies the value that was returned on the CONNECT\_NODE or OPEN\_FILE verb.

### nofvcb

Pointer to a Verb Control Block (VCB) that contains the parameters for the verb being issued. The VCB structure for each verb is described in [Chapter 3, “NOF API Verbs,”](#) on page 35. These structures are defined in the NOF API header file nof\_c.h.

**Note:** The NOF VCBs contain many parameters marked as "reserved"; some of these are used internally by the CS/AIX software, and others are not used in this version but may be used in future versions. Your application must not attempt to access any of these reserved parameters; instead, it must set the entire contents of the VCB to zero to ensure that all of these parameters are zero, before it sets other parameters that are used by the verb. This ensures that CS/AIX will not misinterpret any of its internally-used parameters, and also that your application will continue to work with future CS/AIX versions in which these parameters may be used to provide new functions.

To set the VCB contents to zero, use memset:

```
memset(nofvcb, 0, sizeof(nofvcb));
```

### comp\_proc

The callback routine that the Remote API will call when the verb completes. For more information about the requirements for a callback routine, see [“The callback routine specified on the nof\\_async entry point”](#) on page 28.

### ***corr***

An optional correlator for use by the application. This parameter is defined as a C union so that the application can specify any of three different parameter types: pointer, 32-bit integer, or 16-bit integer.

The Remote API does not use this value, but passes it as a parameter to the callback routine when the verb completes. This value enables the application to correlate the returned information with its other processing.

### ***Returned values***

The asynchronous entry point returns one of the following values:

#### **AP\_COMPLETED**

The verb has already completed. The application can examine the parameters in the VCB to determine whether the verb completed successfully. The Remote API does not call the supplied callback routine for this verb.

#### **AP\_IN\_PROGRESS**

The verb has not yet completed. The application can continue with other processing, including issuing other NOF verbs, provided that they do not depend on the completion of the current verb. However, the application should not attempt to examine or modify the parameters in the VCB supplied to this verb.

The Remote API calls the supplied callback routine to indicate when the verb processing completes. The application can then examine the VCB parameters.

### ***Using the asynchronous entry point***

When using the asynchronous entry point, note the following:

- If an application specifies a null pointer in the *comp\_proc* parameter, the verb will complete synchronously (as though the application issued the verb using the synchronous entry point).
- If the call to *nof\_async* is made from within an application callback, specifying a null pointer in the *comp\_proc* parameter is not permitted. In such cases, the Remote API rejects the verb with a primary return code value of *AP\_PARAMETER\_CHECK* and a secondary return code value of *AP\_SYNC\_NOT\_ALLOWED*.
- The application must not attempt to use or modify any parameters in the VCB until the callback routine has been called.
- Multiple verbs do not necessarily complete in the order in which they were issued. In particular, if an application issues an asynchronous verb followed by a synchronous verb, the completion of the synchronous verb does not guarantee that the asynchronous verb has already completed.

### **The callback routine specified on the *nof\_async* entry point**

When using the asynchronous NOF API entry point, the application must supply a pointer to a callback routine. The Remote API uses this callback routine to indicate verb completion. This section describes how the Remote API uses the callback routine and the functions that the callback routine must perform.

#### ***Callback function***

```
NOF_CALLBACK (*comp_proc);
typedef void (*NOF_CALLBACK) (
    AP_UINT32    target_handle,
    void *       nofvcb,
    AP_CORR      corr,
    AP_UINT32    indic_length
);
typedef union ap_corr {
    void *       corr_p;
    AP_UINT32    corr_l;
    AP_INT32     corr_i;
} AP_CORR;
```



## Supplied parameters

The Remote API calls the callback routine with the following parameters:

### *target\_handle*

This parameter is undefined.

### *nofvcb*

A pointer to the VCB supplied by the application. The VCB now includes the returned parameters set by the Remote API.

### *corr*

The correlator value supplied by the application. This value enables the application to correlate the returned information with its other processing.

The callback routine need not use all of these parameters. It can perform all the necessary processing on the returned parameters, or it can simply set a variable to inform the NOF application that the verb has completed.

## Returned values

The callback function does not return any values.

## Scope of target handle

Each application that needs to use NOF must issue the `CONNECT_NODE` verb to obtain its own handle. No two NOF applications can use the same NOF target handle.

## Compiling and linking the NOF application

This section provides information about compiling and linking NOF applications on Windows.

### Compiler options for structure packing

The VCB structures for NOF verbs are not packed. Do not use compiler options that change this packing method.

*DWORD* parameters are on *DWORD* boundaries, *WORD* parameters are on *WORD* boundaries, and *BYTE* parameters are on *BYTE* boundaries.

### Header files

The NOF header file to be included in Windows NOF applications is named `nof_c.h`. This file is installed in the subdirectory `\sdk` for 32-bit applications, or `\sdk64` for 64-bit applications, within the directory where you installed the Remote API Client on Windows software.

### Load-time linking

To link the application to NOF at load time, link the TP to the API library file `\sdk\winnof32.lib` for 32-bit applications, or `\sdk64\winnof32.lib` for 64-bit applications.

### Run-time linking

To link the application to NOF at run-time, include the following calls in the TP:

- `LoadLibrary` to load the NOF dynamic link library `winnof32.dll`
- `GetProcAddress` to specify each of the NOF entry points required (`nof` and/or `nof_async`)
- `FreeLibrary` when the library is no longer required



# Writing portable applications

---

The following guidelines are provided for writing CS/AIX NOF applications so that they will be portable to other environments:

- Include the NOF header file without any path name prefix. This enables the application to be used in an environment with a different file system. Use include options on the compiler to locate the file (see [“Compiling and linking the NOF application” on page 24](#) or [“Compiling and linking the NOF application” on page 29](#)).
- Use the symbolic constant names for parameter values and return codes, not the numeric values shown in the header file; this ensures that the correct value will be used regardless of the way these values are stored in memory.
- Include a check for return codes other than those applicable to your current operating system (for example using a "default" case in a switch statement), and provide appropriate diagnostics.
- Ensure that any parameters shown as reserved are set to 0 (zero).

## Target for NOF verbs

---

A NOF verb can be directed to any of the following targets:

- A running node (to manage the node's resources)
- The node on a server where the CS/AIX software is running but where the node has not been started (to start the node, to query the node's stored configuration, or to modify the configuration so that the changes take effect when the node is restarted)
- The domain configuration file (to manage domain resources)
- The `sna.net` file (to manage the CS/AIX servers that can act as backup controllers if the controller server is not available)

The target for a particular NOF verb is identified by the *target\_handle* parameter used on the NOF call. An application acquires a target handle using different NOF verbs depending on the target, as follows:

### Running node or node on running server

The application issues `CONNECT_NODE`, specifying the name of the required node, with a null target handle; CS/AIX returns a target handle for this node as one of the VCB parameters for `CONNECT_NODE`.

### Domain configuration file

The application issues `OPEN_FILE` with a null target handle; CS/AIX returns a target handle for the file as one of the VCB parameters for `OPEN_FILE`.

### sna.net file

The application issues `OPEN_FILE` with a null target handle; CS/AIX returns a target handle for the file as one of the VCB parameters for `OPEN_FILE`.

Some NOF verbs can be issued only to particular target types:

- `DEFINE_NODE` cannot be issued to a running node; it must be issued to a server where the node is not running.
- Verbs associated with node resources, such as `DEFINE_LOCAL_LU`, must be issued to a node.
- `START_*` and `STOP_*` verbs, to start and stop node resources, must be issued to a running node.
- Verbs associated with domain resources must be issued to the domain configuration file.
- Different `QUERY_*` verbs return information about the definition of a resource, on its current status, or on both definition and status. Status information can only be obtained from a running node. Verbs that return only status information cannot be issued to an inactive node, and verbs that return both definition and status will return only definition information when issued to an inactive node. For example, `QUERY_PARTNER_LU_DEFINITION` can be issued either to an inactive node (to determine the stored configuration) or to a running node (to determine the current definition). However, `QUERY_PARTNER_LU` (which returns information about the LU's current sessions) can be issued only to

a running node. QUERY\_LS (which returns both the definition of the LS and its current status) can be issued either to an inactive node or to a running node, but status information is not returned if you issue it to an inactive node. The description of each QUERY\_\* verb in Chapter 3, “NOF API Verbs,” on page 35 includes information about the valid target types for the verb.

- Verbs associated with managing backup servers (ADD\_BACKUP, DELETE\_BACKUP, QUERY\_SNA\_NET, and REGISTER\_INDICATION\_SINK or UNREGISTER\_INDICATION\_SINK for SNA network file indications) must be issued to the sna.net file.

## Processing modes

Each target handle used by an application has an associated processing mode that can be modified with the NOF verb SET\_PROCESSING\_MODE. The mode controls file locking and access permissions for the application.

For a NOF application running on a client, read-only mode is the only mode available. Only QUERY\_\* verbs are enabled in this mode. All other verbs, which modify the configuration or status of a resource, will be rejected. This enables the application to check the configuration or status of a resource but not to change it.

For a NOF application running on a server, the following modes are available:

### AP\_MODE\_READ\_ONLY

Only QUERY\_\* verbs are enabled in this mode. All other verbs, which modify the configuration or status of a resource, will be rejected.

This is the default mode when the target handle is first assigned; it enables the application to check the configuration or status of a resource but not to change it.

### AP\_MODE\_READ\_WRITE

All NOF verbs are enabled in this mode, including those that change a resource's configuration or status.

### AP\_MODE\_COMMIT

This mode is only available if the target handle identifies the domain configuration file (not when issuing verbs to a node). It obtains a lock on the file so that only this application can access it; this file lock ensures that the file will not be modified by any other process during a sequence of verbs issued by this application. The file lock also ensures that no changes are made to the file until the complete sequence of verbs has been issued (until the application changes from AP\_MODE\_COMMIT mode to one of the other modes).

Because this mode prevents any other program from accessing the file, it should be used only for as long as necessary. The application should immediately issue all the verbs that it requires to modify the file and then change to one of the other modes.

If the file lock cannot be obtained (for example, because another program is currently modifying the file), the SET\_PROCESSING\_MODE verb will fail.

**Note:** To obtain read/write or commit access to the file, your NOF application must be running with a user ID that is a member of the SNA administrators group system or sna (or running as root). If the user ID is not a member of this group or root, the only valid processing mode is AP\_MODE\_READ\_ONLY.

## Ordering and dependencies between NOF verbs

The main restriction on the order of NOF verbs is that the first reference to a particular resource must be in a DEFINE\_\* verb for that resource. This leads to the following dependencies:

- When creating a new node configuration file, the first verb issued must be DEFINE\_NODE.
- A DLC must be defined before any port that refers to it.
- A port must be defined before any LS or CN that refers to it.
- A COS must be defined before any mode that refers to it.
- A PU name must be defined (as part of an LS definition) before a dependent LU that refers to this PU.

## NOF restrictions based on node configuration

- An LU must be defined before an LU pool that includes it.
- A downstream PU name (as part of an LS definition) and a host LU must be defined before a downstream LU that refers to them.
- A resource must be defined before a START\_\* verb refers to it, and must be started before a STOP\_\* verb refers to it.

In addition, when modifying a running node, using a DEFINE\_\* verb a second time (to modify the previous definition) is not always valid. For some of these verbs, a second definition is never valid (the resource must be deleted and then defined again); for others, a second definition is valid only if the resource is currently inactive. The descriptions of individual DEFINE\_\* verbs in Chapter 3, “NOF API Verbs,” on page 35 provide information about whether a second definition is valid. When modifying the domain configuration file, a second DEFINE\_\* verb can always be used to modify a previous definition.

When creating a new node configuration file, the first verb issued must be DEFINE\_NODE. This must be followed by DEFINE\_\* and SET\_\* verbs for all the resources associated with the node.

In the domain configuration file, there is no restriction on the ordering of domain resource records.

## NOF restrictions based on node configuration

---

The DEFINE\_NODE verb includes parameters that define the range of functions supported by a node. Several NOF verbs relate to optional functions that a node can or can not support; these verbs are valid only when issued to a node that supports the relevant functions.

This section summarizes the optional functions that affect which NOF verbs can be used. For more information about these functions, see “DEFINE\_NODE” on page 145.

### APPN end node and LEN node restrictions

The CS/AIX local node can be an APPN network node, an APPN branch network node, an APPN end node, or a LEN node.

The following NOF verbs are only valid at a network node, branch network node, or end node; the primary return code AP\_FUNCTION\_NOT\_SUPPORTED is returned if you attempt to issue them at a LEN node.

- DEFINE\_CN
- DELETE\_CN
- QUERY\_CN
- QUERY\_CN\_PORT

The following NOF verbs are only valid at a network node or branch network node; the primary return code AP\_FUNCTION\_NOT\_SUPPORTED is returned if you attempt to issue them at an end node or LEN node.

- QUERY\_ADJACENT\_NN
- QUERY\_ISR\_SESSION
- QUERY\_NN\_TOPOLOGY\_NODE
- QUERY\_NN\_TOPOLOGY\_STATS
- QUERY\_NN\_TOPOLOGY\_TG
- REGISTER\_INDICATION\_SINK for any of the following indications:
  - ISR\_INDICATION
  - NN\_TOPOLOGY\_NODE\_INDICATION
  - NN\_TOPOLOGY\_TG\_INDICATION

## Multiple Domain Support (MDS) restrictions

The local node can be run with or without Multiple Domain Support (MDS). The following NOF verbs are only valid at a node running with MDS; the primary return code AP\_FUNCTION\_NOT\_SUPPORTED is returned if you attempt to issue them at a node without MDS.

- QUERY\_ACTIVE\_TRANSACTION
- QUERY\_MDS\_APPLICATION
- QUERY\_MDS\_STATISTICS

## SNA gateway and DLUR restrictions

The local node can be run with or without support for SNA gateway or DLUR or both.

The following NOF verbs are valid only if the node is running with SNA gateway enabled; the primary return code AP\_FUNCTION\_NOT\_SUPPORTED is returned if you attempt to issue them at a node without SNA gateway.

- DEFINE\_DOWNSTREAM\_LU, DEFINE\_DOWNSTREAM\_LU\_RANGE
- DELETE\_DOWNSTREAM\_LU, DELETE\_DOWNSTREAM\_LU\_RANGE

The following NOF verbs are valid only if the node is running with DLUR enabled; the primary return code AP\_FUNCTION\_NOT\_SUPPORTED is returned if you attempt to issue them at a node without DLUR.

- DEFINE\_DLUR\_DEFAULTS
- DEFINE\_INTERNAL\_PU, DELETE\_INTERNAL\_PU
- START\_INTERNAL\_PU, STOP\_INTERNAL\_PU
- QUERY\_DLUR\_LU, QUERY\_DLUR\_PU, QUERY\_DLUS

The following NOF verbs are valid only if the node is running with SNA gateway or DLUR or both enabled; the primary return code AP\_FUNCTION\_NOT\_SUPPORTED is returned if you attempt to issue them at a node without either of these two functions.

- QUERY\_DOWNSTREAM\_LU, QUERY\_DOWNSTREAM\_PU

## List options for QUERY\_\* Verbs

---

A NOF application can obtain information about a particular CS/AIX resource by issuing a QUERY\_\* verb for the appropriate resource type. For example, it can obtain information about the configuration of an LS by issuing QUERY\_LS. These verbs can either return information about a specific resource (for example, the configuration of a particular LS) or about many resources of the same type (for example, a summary of all configured LSs), depending on the options used. In addition, some QUERY\_\* verbs have the option of returning either summary or detailed information about the specified resources. This section explains how to use these options.

### Obtaining information about a single resource or multiple resources

You can think of the information returned by QUERY\_\* verbs as being stored in the form of a list, ordered according to the name of the resource. For example, the information returned by QUERY\_LS is in order of LS name. The normal order of the list (for compatibility with SNMP list ordering) is as follows:

- By name length (shortest name first)
- By ASCII lexicographical ordering for names of the same length

Where the list ordering differs from this (for example, where the list is ordered by a numeric value), this difference is indicated in the individual verb descriptions in [Chapter 3, “NOF API Verbs,” on page 35](#).

This means that an application can obtain information about multiple resources by requesting the complete list or a specified part of it. The following parameters on a QUERY\_\* verb determine which entries from the list are returned:

### ***buf\_size***

Size of the data buffer that the application supplies to receive the returned information.

### ***num\_entries***

Maximum number of resources for which information should be returned. The application can specify 1 to request a specific entry rather than a range, a number greater than 1 to request a range, or 0 (zero) to request as many entries as possible.

### ***list\_options***

The position in the list of the first entry required:

- First entry in the list
- Entries starting from a specific named entry
- Entries starting from the next entry after a specific named entry. (The name specified gives the starting position according to the list ordering and need not exist in the list; for example, if the list contains entries NODEA, NODEB, NODED, NODEF, and the application requests entries starting from the first entry after NODEC, the first entry returned is NODED.)

In addition, if the *list\_options* parameter does not request starting from the first entry, the name of a specific entry in the list is used to indicate the starting position for the required entries.

The number of entries returned is the smallest of the following values:

- The *num\_entries* parameter, if this is nonzero
- The maximum number of entries that the supplied data buffer can hold
- The number of entries between the specified starting position and the end of the list

In addition, the verb returns information about the total number of entries available and the size of the buffer that would be required to return all the entries at once. If the application has not yet received all the information it requires, it can then issue further verbs to obtain the remaining information.

These options enable the application to manage the information it receives, as follows:

- To obtain a specific entry, it sets the index value to the name of that entry, *list\_options* to indicate "start from the named entry", *buf\_size* to at least the size of a single entry, and *num\_entries* to 1.
- To obtain a complete list a few entries at a time, it first sets *list\_options* to indicate "start from beginning of list", and uses either *buf\_size* or *num\_entries* to limit the amount of information returned. If the returned values indicate that there is more information available, it then issues another verb with *list\_options* indicating "start from the following entry" and sets the index value to the name of the last entry received; this second verb then returns the next section of the list. The application repeats this process until it has received all the required entries.

## Obtaining summary or detailed information

Some QUERY\_\* verbs provide the option of returning either summary or detailed information about the specified resources. For example, QUERY\_LOCAL\_LU can return just the LU name and LU alias (summary information) or can also return additional information such as the LU address and session limit (detailed information). The description of each QUERY\_\* verb in [Chapter 3, "NOF API Verbs," on page 35](#) indicates whether the verb includes the option of returning summary or detailed information.

For the verbs that provide this option, the *list\_options* parameter is used to indicate whether summary or detailed information is required, as well as the starting position within the list. To specify these options, you combine two values using a logical OR operation (one value to specify the starting position in the list and one value to specify whether summary or detailed information is required) and set the *list\_options* parameter to the combination of these two values. For verbs that do not provide this option, you simply set *list\_options* to a single value to indicate the starting position in the list.

## Chapter 3. NOF API Verbs

This chapter provides the following information for each NOF API verb:

- Description of the verb's purpose and usage
- Whether the verb can be issued to an active node, an inactive node, the domain configuration file, or the SNA network data file (unless otherwise stated, verbs may be issued either to an active node or to an inactive node)
- Verb control block (VCB) structure, as defined in the NOF API header file `nof_c.h`
- Parameters supplied to the verb by the application
- Parameters returned to the application
- Error return codes for unsuccessful execution

Most parameters supplied to and returned by the NOF interface are hexadecimal values. To simplify coding, these values are represented by meaningful symbolic constants defined in the header file `values_c.h`, which is included by the NOF header file `nof_c.h`. For example, the `opcode` parameter of the `ACTIVATE_SESSION` verb is the hexadecimal value represented by the symbolic constant `AP_ACTIVATE_SESSION`. The file `values_c.h` also includes definitions of parameter types such as `AP_UINT16` that are used in the NOF VCBs.

It is important that you use the symbolic constant and not the hexadecimal value when setting values for supplied parameters, or when testing values of returned parameters. This is because different AIX systems store these values differently in memory, so the value shown may not be in the format recognized by your system.

The error return codes described in this chapter are specific to each verb. Additional return codes, which are common to all NOF API verbs, are described in [Appendix B, "Common return codes,"](#) on page 661.

NOF API indications, which the application can accept by registering using the `REGISTER_INDICATION_SINK` verb, are described separately in [Chapter 4, "NOF Indications,"](#) on page 599.

**Note:** The NOF VCBs contain many parameters marked as "reserved"; some of these are used internally by the CS/AIX software, and others are not used in this version but may be used in future versions. Your application must not attempt to access any of these reserved parameters; instead, it must set the entire contents of the VCB to zero to ensure that all of these parameters are zero, before it sets other parameters that are used by the verb. This ensures that CS/AIX will not misinterpret any of its internally-used parameters, and also that your application will continue to work with future CS/AIX versions in which these parameters may be used to provide new functions.

To set the VCB contents to zero, use `memset`:

```
memset(nofvcb, 0, sizeof(nofvcb));
```

### ACTIVATE\_SESSION

The `ACTIVATE_SESSION` verb requests CS/AIX to activate a session between the local LU and a specified partner LU, using a specified mode. You must issue an `INITIALIZE_SESSION_LIMIT` verb before issuing an `ACTIVATE_SESSION` verb, unless `cnos_permitted` is set to `AP_YES`.

This verb must be issued to a running node.

This verb can be issued from a NOF application running on a client. If it runs on an AIX or Linux client, the NOF application must run with the userid `root`, or with a userid that is a member of the `sys` group (AIX) or `sna` group (Linux).

## VCB structure

```
typedef struct activate_session
{
    AP_UINT16      opcode;           /* verb operation code          */
    unsigned char  reserv2;         /* reserved                     */
    unsigned char  format;          /* reserved                     */
    AP_UINT16      primary_rc;      /* primary return code          */
    AP_UINT32      secondary_rc;    /* secondary return code        */
    unsigned char  lu_name[8];      /* local LU name                */
    unsigned char  lu_alias[8];     /* local LU alias               */
    unsigned char  plu_alias[8];    /* partner LU alias             */
    unsigned char  mode_name[8];    /* mode name                    */
    unsigned char  fqplu_name[17];  /* fully qualified partner LU name */
    unsigned char  polarity;        /* requested session polarity    */
    unsigned char  session_id[8];   /* session ID                   */
    unsigned char  cnos_permitted;   /* is implicit CNOS permitted?  */
    unsigned char  reserv4[15];     /* reserved                     */
} ACTIVATE_SESSION;
```

## Supplied parameters

The application supplies the following parameters:

### ***opcode***

AP\_ACTIVATE\_SESSION

### ***lu\_name***

LU name of the local LU, as defined to CS/AIX. This is an 8-byte type-A EBCDIC string, padded on the right with spaces if the name is shorter than 8 bytes. To indicate that the LU is defined by its LU alias instead of its LU name, set this parameter to 8 binary zeros.

### ***lu\_alias***

LU alias of the local LU, as defined to CS/AIX. This is an 8-byte ASCII string, using any locally displayable characters, padded on the right with spaces if the name is shorter than 8 bytes. This parameter is used only if *lu\_name* is set to zeros.

If both the LU name and the LU alias are set to all zeros, the verb is forwarded to the LU associated with the CP (the default LU).

### ***plu\_alias***

LU alias of the partner LU. This is an 8-byte ASCII string, using any locally displayable characters, padded on the right with spaces if the name is shorter than 8 bytes. To indicate that the partner LU is defined by its fully qualified LU name instead of its LU alias, set this parameter to 8 binary zeros.

### ***mode\_name***

Name of the mode to be used by the LUs. This is an 8-byte alphanumeric type-A EBCDIC string (starting with a letter), padded on the right with EBCDIC spaces if the name is shorter than 8 bytes.

### ***fqplu\_name***

Fully qualified LU name for the partner LU, as defined to CS/AIX. This parameter is used only if the *plu\_alias* field is set to zeros; it is ignored if *plu\_alias* is specified.

The name is a 17-byte EBCDIC string, right-padded with EBCDIC spaces. It consists of a network ID of up to 8 A-string characters, an EBCDIC dot (period) character, and a network name of up to 8 A-string characters.

### ***polarity***

The polarity for the session. Possible values are:

- AP\_POL\_EITHER
- AP\_POL\_FIRST\_SPEAKER
- AP\_POL\_BIDDER

If AP\_POL\_EITHER is set, ACTIVATE\_SESSION activates a first speaker session if available, otherwise a bidder session is activated. If AP\_POL\_FIRST\_SPEAKER or AP\_POL\_BIDDER is set, ACTIVATE\_SESSION only succeeds if a session of the requested polarity is available.



***cnos\_permitted***

Indicates that CNOS processing is permitted. Possible values are:

**AP\_YES**

CNOS processing is permitted.

**AP\_NO**

CNOS processing is not permitted.

If the activation of a new session is not possible because the session limits for the specified mode are reset, and this parameter is set to AP\_YES, implicit CNOS processing will initialize the session limits. Execution of this command is suspended while CNOS processing is active.

**Returned parameters: successful execution**

If the verb executes successfully, CS/AIX returns the following parameters:

***primary\_rc***

AP\_OK

***secondary\_rc***

Possible values are:

**AP\_AS\_NEGOTIATED**

The session was activated successfully; the session limit defined for the mode was negotiated during the activation process.

**AP\_AS\_SPECIFIED**

The session was activated successfully; the session limit was not changed.

***session\_id***

The 8-byte identifier of the activated session.

**Returned parameters: parameter check**

If the verb does not execute because of a parameter error, CS/AIX returns the following parameters:

***primary\_rc***

AP\_PARAMETER\_CHECK

***secondary\_rc***

Possible values are:

**AP\_EXCEEDS\_MAX\_ALLOWED**

The session cannot be activated, because this would exceed the current session limit for this LU-LU-mode combination.

**AP\_INVALID\_LU\_ALIAS**

The *lu\_alias* parameter did not match any defined local LU alias.

**AP\_INVALID\_LU\_NAME**

The *lu\_name* parameter did not match any defined local LU name.

**AP\_INVALID\_PLU\_NAME**

The *fqplu\_name* parameter did not match any defined partner LU name, or the *plu\_alias* parameter did not match any defined partner LU name.

**AP\_INVALID\_CNOS\_PERMITTED**

The value specified in the *cnos\_permitted* parameter was not valid.

Appendix B, “Common return codes,” on page 661 lists further secondary return codes associated with AP\_PARAMETER\_CHECK, which are common to all NOF verbs.

**Returned parameters: activation failure**

If the verb does not execute because of other errors, CS/AIX returns one of the following parameters.

## ADD\_BACKUP

### *primary\_rc*

Possible values are:

#### **AP\_ACTIVATION\_FAIL\_NO\_RETRY**

The session could not be activated because of a condition that requires action (such as a configuration mismatch or a session protocol error). Check the CS/AIX log file for information about the error condition, and correct it before retrying this verb.

#### **AP\_ACTIVATION\_FAIL\_RETRY**

The session could not be activated because of a temporary condition (such as a link failure). Retry the verb, preferably after a timeout to allow the condition to clear. Check the CS/AIX log file for information about the error condition.

## Returned parameters: other conditions

Appendix B, “Common return codes,” on [page 661](#) lists further combinations of primary and secondary return codes that are common to all NOF verbs.

## ADD\_BACKUP

---

An application uses this verb to add a server to the list of backup servers in the `sna.net` file, so that this server can act as the controlling configuration file server if the current controller becomes inactive. The new server is added to the end of the list, so that it will only become the controller if all the other servers listed in the file are inactive.

This verb must be issued to the `sna.net` file.

## VCB structure

```
typedef struct add_backup
{
    AP_UINT16      opcode;           /* verb operation code          */
    unsigned char  reserv2;         /* reserved                      */
    unsigned char  format;         /* reserved                      */
    AP_UINT16      primary_rc;     /* primary return code          */
    AP_UINT32      secondary_rc;   /* secondary return code        */
    unsigned char  backup_name[128]; /* name of backup server to add */
    unsigned char  reserv3[4];     /* reserved                      */
} ADD_BACKUP;
```

## Supplied parameters

The application supplies the following parameters:

### ***opcode***

AP\_ADD\_BACKUP

### ***backup\_name***

The name of the server being added to the list of backup servers.

If the server name includes a . (period) character, CS/AIX assumes that it is a fully-qualified name; otherwise it performs a DNS lookup to determine the server name.

## Returned parameters: successful execution

If the verb executes successfully, CS/AIX returns the following parameters:

### ***primary\_rc***

AP\_OK

### ***secondary\_rc***

Not used.

## Returned parameters: state check

If the verb does not execute because of a state check, CS/AIX returns the following parameters:

### *primary\_rc*

AP\_STATE\_CHECK

### *secondary\_rc*

Possible values are:

#### **AP\_DUPLICATE\_RECORD**

The server name specified is already listed in the file.

#### **AP\_INVALID\_TARGET**

The target handle on the NOF API call specified a configuration file or a node. This verb must be issued to the sna.net file.

Appendix B, “Common return codes,” on page 661 lists further secondary return codes associated with AP\_STATE\_CHECK, which are common to all NOF verbs.

## Returned parameters: other conditions

Appendix B, “Common return codes,” on page 661 lists further combinations of primary and secondary return codes that are common to all NOF verbs.

## ADD\_DLC\_TRACE

This verb specifies tracing on SNA messages sent on a DLC. It can be used to activate tracing on a particular DLC, port, LS, or HPR RTP connection, or on a particular session on a specified LS, and to specify which types of messages are to be traced. It can also be used to activate tracing on all DLCs, ports, link stations, and HPR RTP connections. For more information about how to use CS/AIX tracing, see the *IBM Communications Server for Data Center Deployment on AIX Administration Guide*.

If multiple ADD\_DLC\_TRACE verbs relating to the same resource are issued, a message will be traced if it matches any of the verbs currently active. For example:

- If you issue a verb to trace all messages for a port and its LSs, and then issue a second verb to trace only messages with a specified LFSID for one of the LSs owned by the port, all messages for the LS will continue to be traced (because they match the first verb). If you then use REMOVE\_DLC\_TRACE to remove tracing for the port, messages on the LS with the specified LFSID will continue to be traced (because they match the second verb which is still active), but other messages on this LS will not be traced.
- If you issue a verb to trace XID messages on all resources, and then issue a second verb to trace SC and DFC messages on a particular LS, all three message types will be traced for this LS.

**Note:** The SET\_TRACE\_TYPE verb includes an option to truncate each entry in trace files to a specified length. This option applies to DLC tracing as well as to the kernel component tracing specified by SET\_TRACE\_TYPE.

## VCB structure

```
typedef struct add_dlc_trace
{
    AP_UINT16          opcode;           /* verb operation code      */
    unsigned char     reserv2;          /* reserved                  */
    unsigned char     format;           /* reserved                  */
    AP_UINT16         primary_rc;       /* primary return code      */
    AP_UINT32         secondary_rc;     /* secondary return code    */
    DLC_TRACE_FILTER filter;           /* resource to be traced    */
} ADD_DLC_TRACE;

typedef struct dlc_trace_filter
{
    unsigned char     resource_type;     /* type of resource         */
    unsigned char     resource_name[8]; /* name of resource         */
    SNA_LFSID         lfsid;           /* session identifier       */
}
```

## ADD\_DLC\_TRACE

```
    unsigned char    message_type;    /* type of messages    */
} DLC_TRACE_FILTER;

typedef struct sna_lfsid
{
    union
    {
        AP_UINT16    session_id;
        struct
        {
            unsigned char    sidh;
            unsigned char    sidl;
        } s;
    } uu;
    AP_UINT16    odai;
} SNA_LFSID;
```

## Supplied parameters

The application supplies the following parameters:

### ***opcode***

AP\_ADD\_DLC\_TRACE

### ***filter.resource\_type***

Specifies the resource to be traced, and optionally the specific message types to be traced for this resource. Possible values are:

#### **AP\_ALL\_RESOURCES**

Set up tracing options for all DLCs, ports, link stations, and HPR RTP connections.

#### **AP\_DLC**

Set up tracing options for the DLC named in *resource\_name*, and for all ports and LSs that use this DLC.

#### **AP\_PORT**

Set up tracing options for the port named in *resource\_name*, and for all LSs that use this port.

#### **AP\_LS**

Set up tracing options for the LS named in *resource\_name*.

#### **AP\_RTP\_RESOURCE\_TYPE**

Specify tracing options for the RTP connection named in *resource\_name*.

#### **AP\_PORT\_DEFINED\_LS**

Set up tracing options for the port named in *resource\_name*, and for all defined LSs (but not implicit LSs) that use this port.

#### **AP\_PORT\_IMPLICIT\_LS**

Set up tracing options for the port named in *resource\_name*, and for all implicit LSs (but not defined LSs) that use this port.

### ***filter.resource\_name***

The name of the DLC, port, LS, or RTP connection for which tracing is being activated. This parameter is reserved if *resource\_type* is set to AP\_ALL\_RESOURCES.

If *resource\_type* is set to AP\_RTP\_RESOURCE\_TYPE, you can specify the name of a particular RTP connection (this name begins with the @ character), or you can set this parameter to all zeros to indicate that all RTP traffic is to be traced.

### ***filter.lfsid***

The Local Form Session Identifier for a session on the specified LS. This is only valid for *resource\_type* AP\_LS, and indicates that only messages on this session are to be traced. The structure contains the following three values, which are returned in the SESSION\_STATS section of a QUERY\_SESSION verb:

#### ***filter.lfsid.uu.s.sidh***

Session ID high byte.

#### ***filter.lfsid.uu.s.sidl***

Session ID low byte.

***filter.lfsid.odai***

Origin Destination Assignor Indicator.

***filter.message\_type***

The type of messages to trace for the specified resource or session. Set this parameter to AP\_TRACE\_ALL to trace all messages, or specify one or more of the following values (combined using a logical OR):

**AP\_TRACE\_XID**

XID messages

**AP\_TRACE\_SC**

Session Control RUs

**AP\_TRACE\_DFC**

Data Flow Control RUs

**AP\_TRACE\_FMD**

FMD messages

**AP\_TRACE\_SEGS**

Non-BBIU segments that do not contain an RH

**AP\_TRACE\_CTL**

Messages other than MUs and XIDs

**AP\_TRACE\_NLP**

Trace Network-Layer Protocol messages

**AP\_TRACE\_NC**

Trace Network Control messages

For tracing on an RTP connection, the values AP\_TRACE\_XID, AP\_TRACE\_NLP, and AP\_TRACE\_CTL are ignored. At least one of the other values listed must be specified for RTP tracing.

**Returned parameters: successful execution**

If the verb executes successfully, CS/AIX returns the following parameters:

***primary\_rc***

AP\_OK

***secondary\_rc***

Not used.

**Returned parameters: parameter check**

If the verb does not execute because of a parameter error, CS/AIX returns the following parameters:

***primary\_rc***

AP\_PARAMETER\_CHECK

***secondary\_rc***

Possible values are:

**AP\_INVALID\_RESOURCE\_TYPE**

The *resource\_type* parameter specified a value that was not valid.

**AP\_INVALID\_MESSAGE\_TYPE**

The *message\_type* parameter specified a value that was not valid.

**INVALID\_RTP\_CONNECTION**

The *resource\_name* parameter does not match any RTP connection.

Appendix B, “Common return codes,” on page 661 lists further secondary return codes associated with AP\_PARAMETER\_CHECK, which are common to all NOF verbs.

## Returned parameters: other conditions

Appendix B, “Common return codes,” on page 661 lists further combinations of primary and secondary return codes that are common to all NOF verbs.

## APING

APING is the APPN version of the "ping" utility; it allows a management application to check the communications path from a local LU to a remote LU in the network.

CS/AIX APING is implemented using an internally-defined APPC TP. This TP sends data to the partner LU, and optionally receives data from the partner LU. If the TP completes successfully, the APING verb returns information about the time taken to allocate a conversation to the partner LU and to send and receive data.

The application must supply a VCB that is large enough to include a partner TP verification string of the requested size as well as the basic APING VCB structure; the returned data includes this string appended to the end of the basic structure.

This verb is intended for checking the path to an LU on a remote node. Using APING to check communications with a partner LU on the local node will impact the performance of other programs on the local computer, and is not recommended.

This verb must be issued to a running node.

## VCB structure

```
typedef struct aping
{
    AP_UINT16      opcode;           /* verb operation code          */
    unsigned char  reserv2;         /* reserved                     */
    unsigned char  format;         /* reserved                     */
    AP_UINT16      primary_rc;     /* primary return code          */
    AP_UINT32      secondary_rc;   /* secondary return code        */
    unsigned char  lu_name[8];     /* local LU name                */
    unsigned char  lu_alias[8];    /* local LU alias               */
    AP_UINT32      sense_data;     /* sense data                   */
    unsigned char  plu_alias[8];   /* partner LU alias             */
    unsigned char  mode_name[8];   /* mode name                    */
    unsigned char  tp_name[64];    /* destination TP name          */
    unsigned char  security;       /* security level                */
    unsigned char  reserv3a[3];    /* reserved                     */
    unsigned char  pwd[10];        /* password                      */
    unsigned char  user_id[10];    /* user ID                      */
    AP_UINT16      dlen;           /* length of data to send       */
    AP_UINT16      consec;        /* number of consecutive sends  */
    unsigned char  fqplu_name[17]; /* fully qualified partner LU name */
    unsigned char  echo;          /* data echo flag               */
    AP_UINT16      iterations;    /* number of iterations         */
    AP_UINT32      alloc_time;    /* time taken for ALLOCATE      */
    AP_UINT32      min_time;      /* minimum send/receive time    */
    AP_UINT32      avg_time;      /* average send/receive time    */
    AP_UINT32      max_time;      /* maximum send/receive time    */
    AP_UINT16      partner_ver_len; /* size of string to receive    */
} APING;
```

## Supplied parameters

The application supplies the following parameters:

### *opcode*

AP\_APING

### *lu\_name*

LU name of the local LU. This is an 8-byte type-A EBCDIC string, padded on the right with spaces if the name is shorter than 8 characters. To indicate that the LU is identified by its LU alias instead of its LU name, set this parameter to 8 binary zeros and specify the LU alias in the following parameter.

***lu\_alias***

LU alias of the local LU. This parameter is used only if the *lu\_name* field is set to 8 binary zeros, and is ignored otherwise. The alias is an 8-byte ASCII string, padded on the right with spaces if the name is shorter than 8 bytes. To use the default LU (the LU associated with the CP), set both the *lu\_name* and *lu\_alias* parameters to 8 binary zeros.

***plu\_alias***

Partner LU alias. This should be the alias of an LU on a remote node; you are not recommended to use APING with a partner LU on the local node.

The alias is an 8-byte ASCII string, padded on the right with spaces if the name is shorter than 8 bytes. To indicate that the LU is identified by its fully qualified name instead of its alias, set this parameter to 8 binary zeros and specify the LU name in the *fqplu\_name* parameter.

***mode\_name***

Name of the mode used by the LU pair. This is an 8-byte type-A EBCDIC string (starting with a letter), padded on the right with spaces if the name is shorter than 8 characters.

***tp\_name***

Name of the invoked TP (generally set to APINGD). This is a 64-byte string, padded on the right with spaces.

***security***

Specifies whether conversation security information is required to start the TP. Possible values are:

**AP\_NONE**

No security information is required.

**AP\_SAME**

Security information may be verified by the TP that invoked this TP on behalf of a third TP.

**AP\_PGM**

A user ID and password are required to start the TP.

**AP\_PGM\_STRONG**

A password and user ID are required to start the TP, but the password must not be sent in clear text. If password substitution is not supported on the session, the aping fails. Otherwise, the password is sent encrypted.

***pwd***

Password required to access the partner TP; this parameter is required only if the security parameter is set to AP\_PGM. This is a 10-byte type-AE EBCDIC character string, padded on the right with EBCDIC spaces if the password is shorter than 10 bytes.

***user\_id***

User ID required to access the partner TP; this parameter is required only if the security parameter is set to AP\_SAME or AP\_PGM. This is a 10-byte type-AE EBCDIC character string, padded on the right with EBCDIC spaces if the user ID is shorter than 10 bytes.

***dlen***

Length of the data string to be sent to the partner LU. (The NOF API application does not need to provide a data string; the APING TP simply sends a string of zeros of the specified length.)

***consec***

Number of consecutive data strings sent to the partner LU during each iteration. The APING TP sends this number of data strings, each containing the number of bytes specified by the *dlen* parameter. It then requests either data or a confirmation message from the partner TP, depending on the setting of the *echo* parameter.

***fqplu\_name***

Fully qualified network name for the partner LU. This parameter is used only if the *plu\_alias* field is set to 8 binary zeros, and is ignored otherwise. This should be the name of an LU on a remote node; you are not recommended to use APING with a partner LU on the local node.

The name is a 17-byte EBCDIC string, right-padded with EBCDIC spaces. It consists of a network ID of up to 8 A-string characters, an EBCDIC dot (period) character, and a network name of up to 8 A-string characters.

## APING

### *echo*

Specifies whether the APING TP requests data from the partner LU after sending data to it. Possible values are:

#### **AP\_YES**

After sending the specified number of data strings, APING waits to receive data from the partner LU.

#### **AP\_NO**

After sending the specified number of data strings, APING requests confirmation from the partner LU, but does not receive data.

### *iterations*

Number of times that the APING TP should perform the sequence of sending data to the partner LU and requesting either data or confirmation.

### *partner\_ver\_len*

Maximum length of the partner TP verification data string which can be received by the NOF API application. The application must supply a VCB large enough to include this string as well as the basic APING VCB structure, because the string will be appended to the returned VCB.

## Returned parameters: successful execution

If the verb executes successfully, APING returns the following parameters:

### *primary\_rc*

AP\_OK

### *alloc\_time*

The time in milliseconds to allocate a conversation to the partner (the time taken for the MC\_ALLOCATE verb issued by the APING TP to complete).

### *min\_time*

The minimum time in milliseconds required for a data-sending iteration (the shortest measured time for a single iteration of sending data and receiving either data or confirmation). If iterations was set to zero, this parameter is not used.

### *avg\_time*

The average time in milliseconds required for a data-sending iteration (the average time for a single iteration of sending data and receiving either data or confirmation). If iterations was set to zero, this parameter is not used.

### *max\_time*

The maximum time in milliseconds required for a data-sending iteration (the longest measured time for a single iteration of sending data and receiving either data or confirmation). If iterations was set to zero, this parameter is not used.

### *partner\_ver\_len*

Length of verification string returned by the partner TP.

In addition to these returned parameters, the verification string returned by the partner TP is appended to the end of the APING VCB. The length of this string is given by *partner\_ver\_len*. If *partner\_ver\_len* is zero, then this string is not returned.

## Returned parameters: parameter check

If the verb does not execute because of a parameter error, CS/AIX returns the following parameters:

### *primary\_rc*

AP\_PARAMETER\_CHECK

### *secondary\_rc*

Possible values are:

#### **AP\_INVALID\_LU\_ALIAS**

The *lu\_alias* parameter did not match any defined LU alias.



**AP\_INVALID\_LU\_NAME**

The *lu\_name* parameter did not match any defined LU name.

**AP\_BAD\_SECURITY**

The *security* parameter was not set to a valid value.

**AP\_UNKNOWN\_PARTNER\_MODE**

The value specified for *plu\_alias*, *fqplu\_name*, or *mode\_name* did not match any defined partner LU or mode.

**AP\_BAD\_PARTNER\_LU\_ALIAS**

The value specified for *plu\_alias* did not match any defined partner LU.

Appendix B, “Common return codes,” on page 661 lists further secondary return codes associated with AP\_PARAMETER\_CHECK, which are common to all NOF verbs.

## Returned parameters: allocation failure

If the verb does not execute because CS/AIX cannot allocate the APPC conversation, CS/AIX returns the following parameters:

***primary\_rc***

AP\_ALLOCATION\_ERROR

***secondary\_rc***

Possible values are:

**AP\_ALLOCATION\_FAILURE\_NO\_RETRY**

The conversation cannot be allocated because of a permanent condition, such as a configuration error or session protocol error. Check the *sense\_data* parameter and the error log file for more information. Do not attempt to retry the APING verb until the error has been corrected.

**AP\_ALLOCATION\_FAILURE\_RETRY**

The conversation could not be allocated because of a temporary condition, such as a link failure. Check the error log file for more information. Retry the APING verb, preferably after a timeout to allow the condition to clear.

**AP\_SECURITY\_NOT\_VALID**

The user ID or password specified was not accepted by the partner LU.

**AP\_TP\_NAME\_NOT\_RECOGNIZED**

The partner LU does not recognize the specified TP name.

**AP\_TRANS\_PGM\_NOT\_AVAIL\_NO\_RETRY**

The remote LU rejected the allocation request because it was unable to start the requested partner TP. The condition is permanent. The reason for the error may be logged on the remote node. Do not retry the APING verb until the cause of the error has been corrected.

**AP\_TRANS\_PGM\_NOT\_AVAIL\_RETRY**

The remote LU rejected the allocation request because it was unable to start the requested partner TP. The condition may be temporary, such as a timeout. The reason for the error may be logged on the remote node. Retry the APING verb, preferably after a timeout to allow the condition to clear.

***sense\_data***

If the *secondary\_rc* parameter is AP\_ALLOCATION\_FAILURE\_NO\_RETRY, this parameter contains the SNA sense data associated with the error. For all other *secondary\_rc* values, this parameter is reserved.

## Returned parameters: conversation failure

If the verb does not execute because the APPC conversation with the partner TP failed, CS/AIX returns the following parameters:

## CHANGE\_SESSION\_LIMIT

### *primary\_rc*

#### **AP\_CONV\_FAILURE\_NO\_RETRY**

The conversation was terminated because of a permanent condition, such as a session protocol error. Check the error log file to determine the cause of the error. Do not retry the APING verb until the error has been corrected.

### *primary\_rc*

#### **AP\_CONV\_FAILURE\_RETRY**

The conversation was terminated because of a temporary error. Retry the APING verb. If the problem occurs again, check the error log file to determine the cause of the error.

### *primary\_rc*

#### **AP\_DEALLOC\_ABEND**

The partner TP deallocated the conversation because of an error condition. The reason for the error may be logged on the remote node.

## Returned parameters: other conditions

Appendix B, “Common return codes,” on page 661 lists further combinations of primary and secondary return codes that are common to all NOF verbs.

## CHANGE\_SESSION\_LIMIT

The CHANGE\_SESSION\_LIMIT verb requests CS/AIX to change the session limits for a particular LU-LU-mode combination. Sessions may be activated or deactivated as a result of processing this verb.

This verb must be issued to a running node.

## VCB structure

```
typedef struct change_session_limit
{
    AP_UINT16      opcode;                /* verb operation code          */
    unsigned char  reserv2;               /* reserved                     */
    unsigned char  format;                /* reserved                     */
    AP_UINT16      primary_rc;            /* primary return code          */
    AP_UINT32      secondary_rc;          /* secondary return code        */
    unsigned char  lu_name[8];            /* local LU name                */
    unsigned char  lu_alias[8];           /* local LU alias               */
    unsigned char  plu_alias[8];          /* partner LU alias             */
    unsigned char  fqplu_name[17];        /* fully qualified partner      */
                                                /* LU name                      */
    unsigned char  reserv3;               /* reserved                     */
    unsigned char  mode_name[8];          /* mode name                    */
    unsigned char  reserv3a;              /* reserved                     */
    unsigned char  set_negotiable;        /* set max negotiable limit?    */
    AP_UINT16      plu_mode_session_limit; /* session limit                */
    AP_UINT16      min_conwinners_source; /* minimum source contention     */
                                                /* winner sessions              */
    AP_UINT16      min_conwinners_target; /* minimum target contention     */
                                                /* winner sessions              */
    AP_UINT16      auto_act;              /* auto activation limit        */
    unsigned char  responsible;           /* who is responsible for       */
                                                /* deactivating                 */
    unsigned char  reserv4[3];            /* reserved                     */
    AP_UINT32      sense_data;            /* sense data                   */
} CHANGE_SESSION_LIMIT;
```

## Supplied parameters

The application supplies the following parameters:

### *opcode*

AP\_CHANGE\_SESSION\_LIMIT

***lu\_name***

LU name of the local LU, as defined to CS/AIX. This is an 8-byte type-A EBCDIC string, padded on the right with spaces if the name is shorter than 8 bytes. To indicate that the LU is defined by its LU alias instead of its LU name, set this parameter to 8 binary zeros.

***lu\_alias***

LU alias of the local LU, as defined to CS/AIX. This is an 8-byte ASCII string, using any locally displayable characters, padded on the right with spaces if the name is shorter than 8 bytes. It is used only if *lu\_name* is set to zeros.

To indicate the LU associated with the CP (the default LU), set both *lu\_name* and *lu\_alias* to 8 binary zeros.

***plu\_alias***

LU alias of the partner LU.

This is an 8-byte ASCII string, using any locally displayable characters, padded on the right with spaces if the name is shorter than 8 bytes. To indicate that the partner LU is defined by its fully qualified LU name instead of its LU alias, set this parameter to 8 binary zeros.

***fqplu\_name***

Fully qualified LU name for the partner LU, as defined to CS/AIX. This parameter is used only if the *plu\_alias* field is set to zeros; it is ignored if *plu\_alias* is specified.

The name is a 17-byte EBCDIC string, right-padded with EBCDIC spaces. It consists of a network ID of up to 8 A-string characters, an EBCDIC dot (period) character, and a network name of up to 8 A-string characters.

***mode\_name***

Name of the mode to be used by the LUs.

This is an 8-byte alphanumeric type-A EBCDIC string (starting with a letter), padded on the right with EBCDIC spaces if the name is shorter than 8 bytes.

***set\_negotiable***

Specifies whether the maximum negotiable session limit for this mode should be modified. Possible values are:

**AP\_YES**

Use the value specified by *plu\_mode\_session\_limit* as the maximum negotiable session limit for this LU-LU-mode combination.

**AP\_NO**

Leave the maximum negotiable session limit as the value specified for the mode.

***plu\_mode\_session\_limit***

Requested total session limit for this LU-LU-mode combination: the maximum number of parallel sessions permitted between these two LUs using this mode. Specify a value in the range 1-32,767 (which must not exceed the session limit specified for the local LU on the DEFINE\_LOCAL\_LU verb). This value may be negotiated with the partner LU.

***min\_conwinners\_source***

Minimum number of sessions using this mode for which the local LU is the contention winner. Specify a value in the range 0-32,767. The sum of the *min\_conwinners\_source* and *min\_conwinners\_target* parameters must not exceed the *plu\_mode\_session\_limit* parameter.

***min\_conwinners\_target***

Minimum number of sessions using this mode for which the partner LU is the contention winner. Specify a value in the range 0-32,767. The sum of the *min\_conwinners\_source* and *min\_conwinners\_target* parameters must not exceed the *plu\_mode\_session\_limit* parameter.

***auto\_act***

Number of sessions to automatically activate after the session limit is changed. Specify a value in the range 0-32,767 (which must not exceed the *plu\_mode\_session\_limit* parameter or the session limit specified for the local LU on the DEFINE\_LOCAL\_LU verb). The actual number of automatically activated sessions is the minimum of this value and the negotiated minimum number of contention

## CHANGE\_SESSION\_LIMIT

winner sessions for the local LU. When sessions are deactivated normally (specifying AP\_DEACT\_NORMAL) below this limit, new sessions are activated up to this limit.

### **responsible**

Indicates whether the local or partner LU is responsible for deactivating sessions after the session limit is changed. Possible values are:

#### **AP\_SOURCE**

The local LU is responsible.

#### **AP\_TARGET**

The partner LU is responsible.

## Returned parameters: successful execution

If the verb executes successfully, CS/AIX returns the following parameters:

### **primary\_rc**

AP\_OK

### **secondary\_rc**

Possible values are:

#### **AP\_AS\_NEGOTIATED**

The session limits were changed, but one or more values were negotiated by the partner LU.

#### **AP\_AS\_SPECIFIED**

The session limits were changed as requested, without being negotiated by the partner LU.

## Returned parameters: parameter check

If the verb does not execute because of a parameter error, CS/AIX returns the following parameters:

### **primary\_rc**

AP\_PARAMETER\_CHECK

### **secondary\_rc**

Possible values are:

#### **AP\_EXCEEDS\_MAX\_ALLOWED**

The *plu\_mode\_session\_limit*, *min\_conwinners\_source*, *min\_conwinners\_target*, or *auto\_act* parameter was set to a value outside the valid range.

#### **AP\_CANT\_CHANGE\_TO\_ZERO**

The *plu\_mode\_session\_limit* parameter cannot be set to zero using this verb; use RESET\_SESSION\_LIMIT instead.

#### **AP\_INVALID\_LU\_ALIAS**

The *lu\_alias* parameter did not match any defined local LU alias.

#### **AP\_INVALID\_LU\_NAME**

The *lu\_name* parameter did not match any defined local LU name.

#### **AP\_INVALID\_MODE\_NAME**

The *mode\_name* parameter did not match any defined mode name.

#### **AP\_INVALID\_PLU\_NAME**

The *fqplu\_name* parameter did not match any defined partner LU name.

#### **AP\_INVALID\_RESPONSIBLE**

The *responsible* parameter was not set to a valid value.

#### **AP\_INVALID\_SET\_NEGOTIABLE**

The *set\_negotiable* parameter was not set to a valid value.

Appendix B, "Common return codes," on page 661 lists further secondary return codes associated with AP\_PARAMETER\_CHECK, which are common to all NOF verbs.

## Returned parameters: state check

If the verb does not execute because of a state error, CS/AIX returns the following parameters.

### *primary\_rc*

AP\_STATE\_CHECK

### *secondary\_rc*

#### **AP\_MODE\_RESET**

No sessions are currently active for this LU-LU-mode combination. Use INITIALIZE\_SESSION\_LIMIT instead of CHANGE\_SESSION\_LIMIT to specify the limits.

Appendix B, “Common return codes,” on page 661 lists further secondary return codes associated with AP\_STATE\_CHECK, which are common to all NOF verbs.

## Returned parameters: session allocation error

If the verb does not execute because of a session allocation error, CS/AIX returns the following parameters:

### *primary\_rc*

AP\_ALLOCATION\_ERROR

### *secondary\_rc*

#### **AP\_ALLOCATION\_FAILURE\_NO\_RETRY**

A session could not be allocated because of a condition that requires corrective action. Check the *sense\_data* parameter and any logged messages to determine the reason for the failure, and take any action required. Do not attempt to retry the verb until the condition has been corrected.

### *sense\_data*

The SNA sense data associated with the allocation failure.

## Returned parameters: CNOS processing errors

If the verb does not execute because of an error, CS/AIX returns the following parameters.

### *primary\_rc*

#### **AP\_CONV\_FAILURE\_NO\_RETRY**

The session limits could not be changed because of a condition that requires action (such as a configuration mismatch or a session protocol error). Check the CS/AIX log file for information about the error condition, and correct it before retrying this verb.

### *primary\_rc*

AP\_CNOS\_PARTNER\_LU\_REJECT

### *secondary\_rc*

#### **AP\_CNOS\_COMMAND\_RACE\_REJECT**

The verb failed because the specified mode was being accessed by another administration program (or internally by the CS/AIX software) for session activation or deactivation, or for session limit processing. The application should retry the verb, preferably after a timeout to allow the race condition to be cleared.

## Returned parameters: other conditions

Appendix B, “Common return codes,” on page 661 lists further combinations of primary and secondary return codes that are common to all NOF verbs.

## CLOSE\_FILE

An application uses this verb to release its handle to the domain configuration file, or to the `sna.net` file, when it has finished issuing NOF verbs to the file. The file which the application wishes to close is identified by the *target\_handle* parameter on the call.

The application should always issue CLOSE\_FILE for any open file handles before it exits. After the verb completes successfully, the target handle identifying the file is no longer valid.

This verb must be issued to the domain configuration file or to the `sna.net` file.

### VCB structure

```
typedef struct close_file
{
    AP_UINT16      opcode;           /* verb operation code      */
    unsigned char  reserv2;         /* reserved                  */
    unsigned char  format;         /* reserved                  */
    AP_UINT16      primary_rc;     /* primary return code      */
    AP_UINT32      secondary_rc;   /* secondary return code    */
} CLOSE_FILE;
```

### Supplied parameters

The application supplies the following parameters:

#### *opcode*

AP\_CLOSE\_FILE

### Returned parameters: successful execution

If the verb executes successfully, CS/AIX returns the following parameters:

#### *primary\_rc*

AP\_OK

#### *secondary\_rc*

Not used.

### Returned parameters: state check

If the verb does not execute because of a state check, CS/AIX returns the following parameters:

#### *primary\_rc*

AP\_STATE\_CHECK

#### *secondary\_rc*

##### **AP\_VERB\_IN\_PROGRESS**

The specified file cannot be released because a previous verb issued for this target handle is still outstanding. All verbs for the target file must be completed before attempting to close the file.

Appendix B, “Common return codes,” on page 661 lists further secondary return codes associated with AP\_STATE\_CHECK, which are common to all NOF verbs.

### Returned parameters: other conditions

Appendix B, “Common return codes,” on page 661 lists further combinations of primary and secondary return codes that are common to all NOF verbs.

## CONNECT\_NODE

An application uses this verb in order to establish communications with a CS/AIX node (active or inactive). The verb returns a target handle identifying the node, which the application can then use on other NOF verbs to indicate the target for the verb.

### VCB structure

```
typedef struct connect_node
{
    AP_UINT16      opcode;          /* verb operation code          */
    unsigned char  reserv2;        /* reserved                      */
    unsigned char  format;        /* reserved                      */
    AP_UINT16      primary_rc;     /* primary return code          */
    AP_UINT32      secondary_rc;   /* secondary return code        */
    unsigned char  node_type;     /* which node to connect to    */
    unsigned char  node_name[128]; /* name of Node                 */
    AP_UINT32      target_handle;  /* handle for subsequent verbs  */
    unsigned char  node_status;   /* node status                  */
    unsigned char  reserv3[12];   /* reserved                      */
} CONNECT_NODE;
```

### Supplied parameters

The application supplies the following parameters:

#### **opcode**

AP\_CONNECT\_NODE

#### **node\_type**

To connect to a particular node in order to manage the node's configuration, set this parameter to AP\_SPECIFIED\_NODE.

To connect to the node currently acting as the central logger, set this parameter to AP\_CENTRAL\_LOGGER. This value is required if the application will be issuing the following verbs:

- SET\_CENTRAL\_LOGGING, QUERY\_CENTRAL\_LOGGING
- SET\_GLOBAL\_LOG\_TYPE, QUERY\_GLOBAL\_LOG\_TYPE
- SET\_LOG\_FILE, QUERY\_LOG\_FILE (if central logging is in use)

#### **node\_name**

Name of the CS/AIX node to connect to. This parameter is reserved if *node\_type* is set to AP\_CENTRAL\_LOGGER.

If the node name includes a . (period) character, CS/AIX assumes that it is a fully-qualified name; otherwise it performs a DNS lookup to determine the node name.

If CS/AIX is running with all components on a single computer, you can set this parameter to all binary zeros; there is no need to specify the node name. Otherwise, setting this parameter to all binary zeros indicates the default local node (on the same CS/AIX server as the application).

### Returned parameters: successful execution

If the verb executes successfully, CS/AIX returns the following parameters:

#### **primary\_rc**

AP\_OK

#### **secondary\_rc**

Not used.

#### **target\_handle**

Returned value for use on subsequent verbs.

#### **node\_status**

Specifies the status of the node. Possible values are:

## DEACTIVATE\_CONV\_GROUP

### **AP\_NDE\_STARTING**

The node is in the process of being activated.

### **AP\_NDE\_STARTED**

The node is active.

### **AP\_NDE\_STOPPING**

The node is in the process of being deactivated.

### **AP\_NDE\_STOPPED**

The node is not active.

## Returned parameters: parameter check

If the verb does not execute because of a parameter error, CS/AIX returns the following parameters:

### ***primary\_rc***

AP\_PARAMETER\_CHECK

### ***secondary\_rc***

#### **AP\_INVALID\_NODE\_NAME**

The value that was specified for the *node\_name* parameter was not valid.

Appendix B, “Common return codes,” on page 661 lists further secondary return codes associated with AP\_PARAMETER\_CHECK, which are common to all NOF verbs.

## Returned parameters: state check

If the verb does not execute because of a state error, CS/AIX returns the following parameters:

### ***primary\_rc***

AP\_STATE\_CHECK

### ***secondary\_rc***

Possible values are:

#### **AP\_CONNECTION\_NOT\_MADE**

An error occurred in connecting to the node.

#### **AP\_INVALID\_VERSION**

The application could not connect to the node, because there was a version mismatch between the CS/AIX software on the computer where the application is running and the computer where the target node is defined. If you are in the process of upgrading the network, so that different computers are running different levels of the CS/AIX software, nodes running on the back-level software can be managed only by applications running on the back-level software.

Appendix B, “Common return codes,” on page 661 lists further secondary return codes associated with AP\_STATE\_CHECK, which are common to all NOF verbs.

## Returned parameters: other conditions

Appendix B, “Common return codes,” on page 661 lists further combinations of primary and secondary return codes that are common to all NOF verbs.

## DEACTIVATE\_CONV\_GROUP

---

The DEACTIVATE\_CONV\_GROUP verb requests the deactivation of the session corresponding to the specified conversation group. Although this verb is part of the NOF API, it is primarily intended for use by application programmers writing TPs that use the APPC API. The conversation group identifier is returned by the APPC verbs [MC\_]ALLOCATE, [MC\_]GET\_ATTRIBUTES, and RECEIVE\_ALLOCATE.

This verb must be issued to a running node.



## VCB structure

```
typedef struct deactivate_conv_group
{
    AP_UINT16      opcode;          /* verb operation code          */
    unsigned char  reserv2;        /* reserved                     */
    unsigned char  format;        /* reserved                     */
    AP_UINT16      primary_rc;     /* primary return code         */
    AP_UINT32      secondary_rc;  /* secondary return code       */
    unsigned char  lu_name[8];    /* local LU name               */
    unsigned char  lu_alias[8];   /* local LU alias              */
    AP_UINT32      conv_group_id; /* conversation group identifier */
    unsigned char  type;          /* deactivation type           */
    unsigned char  reserv3[3];    /* reserved                    */
    AP_UINT32      sense_data;    /* deactivation sense data     */
} DEACTIVATE_CONV_GROUP;
```

## Supplied parameters

The application supplies the following parameters:

### ***opcode***

AP\_DEACTIVATE\_CONV\_GROUP

### ***lu\_name***

LU name of the local LU, as defined to CS/AIX. This is an 8-byte type-A EBCDIC string, padded on the right with spaces if the name is shorter than 8 bytes. To indicate that the LU is defined by its LU alias instead of its LU name, set this parameter to 8 binary zeros.

### ***lu\_alias***

LU alias of the local LU, as defined to CS/AIX. This is an 8-byte ASCII string, using any locally displayable characters, padded on the right with spaces if the name is shorter than 8 bytes. It is used only if *lu\_name* is set to zeros.

To indicate the LU associated with the CP (the default LU), set both *lu\_name* and *lu\_alias* to 8 binary zeros.

### ***conv\_group\_id***

Conversation group identifier for the session to be deactivated.

### ***type***

Type of deactivation. Possible values are:

#### **AP\_DEACT\_CLEANUP**

Deactivate the session immediately, without waiting for sessions to end.

#### **AP\_DEACT\_NORMAL**

Do not deactivate the session until all conversations using the session have ended.

### ***sense\_data***

If type is set to AP\_DEACT\_CLEANUP, this parameter specifies the sense data to be used when deactivating the session. Otherwise this parameter is not used.

## Returned parameters: successful execution

If the verb executes successfully, CS/AIX returns the following parameters:

### ***primary\_rc***

AP\_OK

## Returned parameters: parameter check

If the verb does not execute because of a parameter error, CS/AIX returns the following parameters:

### ***primary\_rc***

AP\_PARAMETER\_CHECK

## DEACTIVATE\_LU\_0\_TO\_3

### *secondary\_rc*

Possible values are:

#### **AP\_DEACT\_CG\_INVALID\_CGID**

The *conv\_group\_id* parameter did not match any valid conversation group ID.

#### **AP\_INVALID\_CLEANUP\_TYPE**

The *type* parameter was not set to a valid value.

#### **AP\_INVALID\_LU\_ALIAS**

The *lu\_alias* parameter did not match any defined LU alias.

#### **AP\_INVALID\_LU\_NAME**

The *lu\_name* parameter did not match any defined LU name.

Appendix B, “Common return codes,” on page 661 lists further secondary return codes associated with AP\_PARAMETER\_CHECK, which are common to all NOF verbs.

## Returned parameters: other conditions

Appendix B, “Common return codes,” on page 661 lists further combinations of primary and secondary return codes that are common to all NOF verbs.

## DEACTIVATE\_LU\_0\_TO\_3

---

The DEACTIVATE\_LU\_0\_TO\_3 verb requests CS/AIX to deactivate the session for a particular LU for use with 3270 emulation or LUA (an LU of type 0, 1, 2, or 3). CS/AIX deactivates the session by sending a TERM\_SELF message to the host for the PLU-SLU session.

This verb must be issued to a running node.

## VCB structure

```
typedef struct deactivate_lu_0_to_3
{
    AP_UINT16      opcode;                /* verb operation code      */
    unsigned char  reserv2;
    unsigned char  format;
    AP_UINT16      primary_rc;           /* primary return code      */
    AP_UINT32      secondary_rc;        /* secondary return code    */
    unsigned char  lu_name[8];          /* LU Name                   */
} DEACTIVATE_LU_0_TO_3;
```

## Supplied parameters

The application supplies the following parameters:

### *opcode*

AP\_DEACTIVATE\_LU\_0\_TO\_3

### *lu\_name*

LU name of the LU, as defined to CS/AIX. This is an 8-byte type-A EBCDIC string, padded on the right with spaces if the name is shorter than 8 bytes.

## Returned parameters: successful execution

If the verb executes successfully, CS/AIX returns the following parameters. This return code can also indicate that there was no active session for the specified LU (implying that the session has already been deactivated).

### *primary\_rc*

AP\_OK

## Returned parameters: parameter check

If the verb does not execute because of a parameter error, CS/AIX returns the following parameters:

### *primary\_rc*

AP\_PARAMETER\_CHECK

### *secondary\_rc*

Possible values are:

#### **AP\_INVALID\_LU\_NAME**

The *lu\_name* parameter did not match any defined LU name.

Appendix B, “Common return codes,” on page 661 lists further secondary return codes associated with AP\_PARAMETER\_CHECK, which are common to all NOF verbs.

## Returned parameters: other conditions

Appendix B, “Common return codes,” on page 661 lists further combinations of primary and secondary return codes that are common to all NOF verbs.

## DEACTIVATE\_SESSION

The DEACTIVATE\_SESSION verb requests CS/AIX to deactivate a particular session, or all sessions on a particular mode.

This verb must be issued to a running node.

## VCB structure

```
typedef struct deactivate_session
{
    AP_UINT16      opcode;           /* verb operation code          */
    unsigned char  reserv2;         /* reserved                     */
    unsigned char  format;         /* reserved                     */
    AP_UINT16      primary_rc;     /* primary return code          */
    AP_UINT32      secondary_rc;   /* secondary return code        */
    unsigned char  lu_name[8];     /* local LU name                */
    unsigned char  lu_alias[8];    /* local LU alias               */
    unsigned char  session_id[8];  /* session identifier           */
    unsigned char  plu_alias[8];   /* partner LU alias             */
    unsigned char  mode_name[8];   /* mode name                    */
    unsigned char  type;           /* deactivation type            */
    unsigned char  reserv3[3];     /* reserved                     */
    AP_UINT32      sense_data;     /* deactivation sense data      */
    unsigned char  fqplu_name[17]; /* fully qualified partner      */
                                /* LU name                      */
    unsigned char  reserv4[20];    /* reserved                     */
} DEACTIVATE_SESSION;
```

## Supplied parameters

The application supplies the following parameters:

### *opcode*

AP\_DEACTIVATE\_SESSION

### *lu\_name*

LU name of the local LU, as defined to CS/AIX. This is an 8-byte type-A EBCDIC string, padded on the right with spaces if the name is shorter than 8 bytes. To indicate that the LU is defined by its LU alias instead of its LU name, set this parameter to 8 binary zeros.

### *lu\_alias*

LU alias of the local LU, as defined to CS/AIX. This is an 8-byte ASCII string, using any locally displayable characters, padded on the right with spaces if the name is shorter than 8 bytes. It is used only if *lu\_name* is set to zeros.

## DEACTIVATE\_SESSION

To indicate the LU associated with the CP (the default LU), set both *lu\_name* and *lu\_alias* to 8 binary zeros.

### ***session\_id***

8-byte identifier of the session to deactivate. If this field is set to 8 binary zeros, CS/AIX deactivates all sessions for the partner LU and mode.

### ***plu\_alias***

LU alias of the partner LU.

This is an 8-byte ASCII string, using any locally displayable characters, padded on the right with spaces if the name is shorter than 8 bytes. To indicate that the partner LU is defined by its fully qualified LU name instead of its LU alias, set this parameter to 8 binary zeros.

### ***mode\_name***

Name of the mode to be used by the LUs.

This is an 8-byte alphanumeric type-A EBCDIC string (starting with a letter), padded on the right with EBCDIC spaces if the name is shorter than 8 bytes.

### ***type***

Type of deactivation. Possible values are:

#### **AP\_DEACT\_CLEANUP**

Deactivate the session immediately, without waiting for sessions to end.

#### **AP\_DEACT\_NORMAL**

Do not deactivate the session until all conversations using the session have ended.

### ***sense\_data***

If *type* is set to AP\_DEACT\_CLEANUP, this parameter specifies the sense data to be used when deactivating the session. Otherwise this parameter is not used.

### ***fqplu\_name***

Fully qualified LU name for the partner LU, as defined to CS/AIX. This parameter is used only if the *plu\_alias* field is set to zeros; it is ignored if *plu\_alias* is specified.

The name is a 17-byte EBCDIC string, right-padded with EBCDIC spaces. It consists of a network ID of up to 8 A-string characters, an EBCDIC dot (period) character, and a network name of up to 8 A-string characters.

## Returned parameters: successful execution

If the verb executes successfully, CS/AIX returns the following parameters. This return code can also indicate that the session ID did not match the session ID of an active session (implying that the session has already been deactivated).

### ***primary\_rc***

AP\_OK

## Returned parameters: parameter check

If the verb does not execute because of a parameter error, CS/AIX returns the following parameters:

### ***primary\_rc***

AP\_PARAMETER\_CHECK

### ***secondary\_rc***

Possible values are:

#### **AP\_INVALID\_CLEANUP\_TYPE**

The *type* parameter was not set to a valid value.

#### **AP\_INVALID\_LU\_ALIAS**

The *lu\_alias* parameter did not match any defined LU alias.

**AP\_INVALID\_LU\_NAME**

The *lu\_name* parameter did not match any defined LU name.

**AP\_INVALID\_MODE\_NAME**

The *mode\_name* parameter did not match any defined mode name.

**AP\_INVALID\_PLU\_NAME**

The *fqplu\_name* parameter did not match any defined partner LU name.

Appendix B, “Common return codes,” on page 661 lists further secondary return codes associated with AP\_PARAMETER\_CHECK, which are common to all NOF verbs.

## Returned parameters: other conditions

Appendix B, “Common return codes,” on page 661 lists further combinations of primary and secondary return codes that are common to all NOF verbs.

## DEFINE\_ADJACENT\_LEN\_NODE

DEFINE\_ADJACENT\_LEN\_NODE adds entries to the node directory database for an adjacent LEN node and its associated LUs, or adds additional LU entries for a previously-defined LEN node.

This verb is equivalent to a series of DEFINE\_DIRECTORY\_ENTRY verbs for the LEN node and its associated LUs; it provides a fast method of defining the LEN node's configuration with a single verb. To query the directory entries created by this verb, use QUERY\_DIRECTORY\_ENTRY.

If this verb is issued to the network node acting as the server for the LEN node, the LEN node's resources are added to the network node's directory database. This means that the network node will respond to network searches for these resources, so that they are accessible to the entire network. If the verb is issued to an end node, the LEN node's resources are accessible only to that end node.

## VCB structure

```
typedef struct define_adjacent_len_node
{
    AP_UINT16      opcode;           /* verb operation code          */
    unsigned char  reserv2;         /* reserved                     */
    unsigned char  format;         /* reserved                     */
    AP_UINT16      primary_rc;     /* primary return code          */
    AP_UINT32      secondary_rc;   /* secondary return code        */
    unsigned char  cp_name[17];    /* CP name                      */
    unsigned char  description[32]; /* resource description         */
    unsigned char  reserv1[16];    /* reserved                     */
    unsigned char  num_of_lus;     /* number of LUs               */
    unsigned char  wildcard_lus;   /* wildcard LUs                */
    unsigned char  reserv3[8];     /* reserved                     */
    unsigned char  lu_names[10][8]; /* LU names                    */
} DEFINE_ADJACENT_LEN_NODE;
```

## Supplied parameters

The application supplies the following parameters:

**opcode**

AP\_DEFINE\_ADJACENT\_LEN\_NODE

**cp\_name**

The fully qualified name of the CP in the adjacent LEN node. This should match the name the LEN node sends on its XIDs (if it supports them), and the adjacent CP name specified on the DEFINE\_LS for the link to the LEN node.

The name is a 17-byte EBCDIC string, right-padded with EBCDIC spaces. It consists of a network ID of up to 8 A-string characters, an EBCDIC dot (period) character, and a network name of up to 8 A-string characters.

## DEFINE\_ADJACENT\_LEN\_NODE

### *description*

A null-terminated text string (0-31 characters followed by a null character) describing the adjacent LEN node. This string is for information only; it is stored in the configuration and returned on the QUERY\_DIRECTORY\_ENTRY verb, but CS/AIX does not make any other use of it.

### *num\_of\_lus*

The number of LUs to be defined, in the range 0-10. To define an adjacent node with more than 10 LUs, use multiple DEFINE\_ADJACENT\_LEN\_NODE verbs for the same CP name.

### *wildcard\_lus*

Indicates whether the specified LU names are wildcard entries or explicit LU names. Possible values are:

#### **AP\_YES**

The specified LU names are wildcard entries.

#### **AP\_NO**

The specified LU names are explicit entries.

### *lu\_names*

The names of the LUs being defined on the LEN node. Each name is an 8-byte type-A EBCDIC character string, right-padded with EBCDIC spaces, corresponding to the second part of the fully qualified LU name (the first part of the fully qualified name is defined by the *cp\_name* parameter above).

To define the LU associated with the LEN node's control point (the CP LU or default LU), specify the node's fully qualified CP name in the *cp\_name* parameter, and include the "network name" part of this name (the 8 characters after the EBCDIC dot) as one of the LU names.

You can specify a wildcard LU name to match multiple LU names, by specifying only the initial characters of the name. For example, the wildcard LU name "LU" will match "LUNAME" or "LU01" (but will not match "NAMELU"). However, all the LU names specified on a single verb must be of the same type (wildcard or explicit), as defined by the *wildcard\_lus* parameter. To add both types of LU names for the same LEN node, use multiple DEFINE\_ADJACENT\_LEN\_NODE verbs.

## Returned parameters: successful execution

If the verb executes successfully, CS/AIX returns the following parameters:

### *primary\_rc*

AP\_OK

## Returned parameters: parameter check

If the verb does not execute because of a parameter error, CS/AIX returns the following parameters:

### *primary\_rc*

AP\_PARAMETER\_CHECK

### *secondary\_rc*

Possible values are:

#### **AP\_INVALID\_CP\_NAME**

The *cp\_name* parameter contained a character that was not valid.

#### **AP\_INVALID\_LU\_NAME**

One or more of the specified LU names contained a character that was not valid.

#### **AP\_INVALID\_NUM\_LUS**

The *num\_of\_lus* parameter was not in the valid range.

#### **AP\_INVALID\_WILDCARD\_NAME**

The *wildcard\_lus* parameter was set to AP\_YES, but one or more of the specified LU names was already defined on a different parent node.

## Returned parameters: state check

If the verb does not execute because of a state error, CS/AIX returns the following parameters.

### *primary\_rc*

AP\_STATE\_CHECK

### *secondary\_rc*

Possible values are:

#### **AP\_INVALID\_CP\_NAME**

The specified CP name is already defined in a directory entry, and is not a LEN node.

#### **AP\_INVALID\_LU\_NAME**

One or more of the specified LU names was already defined on a different parent node.

## Returned parameters: other conditions

Appendix B, “Common return codes,” on page 661 lists further combinations of primary and secondary return codes that are common to all NOF verbs.

## DEFINE\_CN

DEFINE\_CN defines a Connection Network (otherwise known as a Virtual Routing Node or VRN). The verb provides the network qualified name of the connection network along with its Transmission Group (TG) characteristics. Also provided is a list of the names of the local ports that can access this connection network.

DEFINE\_CN can be used to redefine an existing Connection Network. In particular, new ports can be added to the list of ports which access the connection network by issuing another DEFINE\_CN. (Ports can be removed in the same way by issuing the DELETE\_CN verb).

This verb is valid only at a network node or an end node, and not at a LEN node.

## VCB structure

```
typedef struct define_cn
{
    AP_UINT16      opcode;           /* verb operation code      */
    unsigned char  reserv2;         /* reserved                  */
    unsigned char  format;         /* reserved                  */
    AP_UINT16      primary_rc;     /* primary return code      */
    AP_UINT32      secondary_rc;   /* secondary return code    */
    unsigned char  fqcn_name[17];  /* name of connection network */
    CN_DEF_DATA    def_data;       /* CN defined data          */
    unsigned char  port_name[8][8]; /* port names                */
} DEFINE_CN;
```

```
typedef struct cn_def_data
{
    unsigned char  description[32]; /* resource description     */
    unsigned char  reserve0[16];   /* reserved                 */
    unsigned char  num_ports;      /* number of ports on CN   */
    unsigned char  cn_type;        /* reserved                 */
    unsigned char  ipv6_addr_only; /* use IPv6 address        */
    unsigned char  reserve1[14];   /* reserved                 */
    TG_DEFINED_CHARS tg_chars;     /* TG characteristics      */
} CN_DEF_DATA;
```

```
typedef struct tg_defined_chars
{
    unsigned char  effect_cap;     /* effective capacity       */
    unsigned char  reserve1[5];    /* reserved                 */
    unsigned char  connect_cost;  /* connection cost         */
    unsigned char  byte_cost;     /* byte cost                */
    unsigned char  reserve2;      /* reserved                 */
    unsigned char  security;      /* security                 */
    unsigned char  prop_delay;    /* propagation delay       */
    unsigned char  modem_class;   /* reserved                 */
}
```

## DEFINE\_CN

```
    unsigned char    user_def_parm_1;    /* user-defined parameter 1    */
    unsigned char    user_def_parm_2;    /* user-defined parameter 2    */
    unsigned char    user_def_parm_3;    /* user-defined parameter 3    */
} TG_DEFINED_CHARS;
```

## Supplied parameters

The application supplies the following parameters:

### **opcode**

AP\_DEFINE\_CN

### **fqcn\_name**

Fully qualified name of the connection network. The name is a 17-byte EBCDIC string, right-padded with EBCDIC spaces. It consists of a network ID of up to 8 A-string characters, an EBCDIC dot (period) character, and a network name of up to 8 A-string characters.

### **def\_data.description**

A null-terminated text string (0-31 characters followed by a null character) describing the connection network. This string is for information only; it is stored in the node's configuration file and returned on the QUERY\_CN verb, but CS/AIX does not make any other use of it.

### **def\_data.num\_ports**

Number of ports included on this verb; each DEFINE\_CN verb can specify up to 8 ports. To define a CN with more than 8 ports, issue multiple DEFINE\_CN verbs for the same CN name; the maximum total number of ports on a CN is 239.

### **def\_data.ipv6\_address\_only**

When defining a Connection Network on an IPv6 network for HPR/IP, this parameter indicates if the IP addressing for the Connection Network will use IPv6 DNS names only or IPv6 addresses only. Possible values are:

#### **YES**

IP addressing for the Connection Network will use IPv6 addresses only.

#### **NO**

IP addressing for the Connection Network will use IPv6 DNS names only.

### **def\_data.tg\_chars.effect\_cap**

Actual bits per second rate (line speed). The value is encoded as a 1-byte floating point number, represented by the formula  $0.1 \text{ mmm} * 2^{\text{eeee}}$  where the bit representation of the byte is 'b'eeeeemmm'. Each unit of effective capacity is equal to 300 bits per second.

### **def\_data.tg\_chars.connect\_cost**

Cost per connect time. Valid values are integer values in the range 0-255, where 0 is the lowest cost per connect time and 255 is the highest.

### **def\_data.tg\_chars.byte\_cost**

Cost per byte. Valid values are integer values in the range 0-255, where 0 is the lowest cost per byte and 255 is the highest.

### **def\_data.tg\_chars.security**

Security level of the network. Possible values are:

#### **AP\_SEC\_NONSECURE**

No security.

#### **AP\_SEC\_PUBLIC\_SWITCHED\_NETWORK**

Data is transmitted over a public switched network.

#### **AP\_SEC\_UNDERGROUND\_CABLE**

Data is transmitted over secure underground cable.

#### **AP\_SEC\_SECURE\_CONDUIT**

Data is transmitted over a line in a secure conduit that is not guarded.

#### **AP\_SEC\_GUARDED\_CONDUIT**

Data is transmitted over a line in a conduit that is protected against physical tapping.



**AP\_SEC\_ENCRYPTED**

Data is encrypted before transmission over the line.

**AP\_SEC\_GUARDED\_RADIATION**

Data is transmitted over a line that is protected against physical and radiation tapping.

***def\_data.tg\_chars.prop\_delay***

Propagation delay: the time that a signal takes to travel the length of the link. Specify one of the following values, according to the type of link:

**AP\_PROP\_DELAY\_MINIMUM**

Minimum propagation delay.

**AP\_PROP\_DELAY\_LAN**

Delay is less than 480 microseconds (typical for a LAN).

**AP\_PROP\_DELAY\_TELEPHONE**

Delay is in the range 480-49,512 microseconds (typical for a telephone network).

**AP\_PROP\_DELAY\_PKT\_SWITCHED\_NET**

Delay is in the range 49,512-245,760 microseconds (typical for a packet-switched network).

**AP\_PROP\_DELAY\_SATELLITE**

Delay is greater than 245,760 microseconds (typical for a satellite link).

**AP\_PROP\_DELAY\_MAXIMUM**

Maximum propagation delay.

***def\_data.tg\_chars.user\_def\_parm\_1* through *def\_data.tg\_chars.user\_def\_parm\_3***

User-defined parameters, which you can use to include other TG characteristics not covered by the above parameters. Each of these parameters must be set to a value in the range 0-255.

***port\_name***

Array of up to eight port names defined on the connection network. Each port name is an 8-byte ASCII string, padded on the right with spaces if the name is shorter than 8 bytes, and must already have been defined by a DEFINE\_PORT verb. The port type must be a network type that supports connection networks (Ethernet, Token Ring, Enterprise Extender). Additional ports may be defined on the Connection Network by issuing another DEFINE\_CN specifying the new port names.

## Returned parameters: successful execution

If the verb executes successfully, CS/AIX returns the following parameter:

***primary\_rc***

AP\_OK

## Returned parameters: parameter check

If the verb does not execute because of a parameter error, CS/AIX returns the following parameters:

***primary\_rc***

AP\_PARAMETER\_CHECK

***secondary\_rc***

Possible values are:

**AP\_DEF\_LINK\_INVALID\_SECURITY**

The *security* parameter was not set to one of the valid values.

**AP\_EXCEEDS\_MAX\_ALLOWED**

Adding the specified number of ports would exceed the maximum total number of ports on a CN.

**AP\_INVALID\_CN\_NAME**

The *fqcn\_name* parameter contained a character that was not valid or was not in the correct format.

**AP\_INVALID\_NUM\_PORTS\_SPECIFIED**

The *num\_ports* parameter was not set to a valid value.

## DEFINE\_COS

### AP\_INVALID\_PORT\_NAME

One or more of the port names specified did not match the name of a defined port.

### AP\_INVALID\_PORT\_TYPE

One or more of the specified ports cannot be on a CN because its DLC type is a point-to-point type (such as SDLC) rather than a network type.

Appendix B, "Common return codes," on page 661 lists further secondary return codes associated with AP\_PARAMETER\_CHECK, which are common to all NOF verbs.

## Returned parameters: state check

If the verb does not execute because of a state error, CS/AIX returns the following parameters:

### *primary\_rc*

AP\_STATE\_CHECK

### *secondary\_rc*

Possible values are:

### AP\_PORT\_ACTIVE

The specified port cannot be modified because it is currently active.

Appendix B, "Common return codes," on page 661 lists further secondary return codes associated with AP\_STATE\_CHECK, which are common to all NOF verbs.

## Returned parameters: function not supported

If the verb does not execute successfully because the local node is a LEN node, CS/AIX returns the following parameters:

### *primary\_rc*

### AP\_FUNCTION\_NOT\_SUPPORTED

The local node is a LEN node. This verb is valid only at a network node or an end node.

## Returned parameters: other conditions

Appendix B, "Common return codes," on page 661 lists further combinations of primary and secondary return codes that are common to all NOF verbs.

## DEFINE\_COS

DEFINE\_COS adds a class of service definition or modifies a previously defined COS. The definition specifies TG "rows" and node "rows", which associate a range of node and TG characteristics with weights used for route calculation. The lower the weight the more favorable the route.

## VCB structure

The DEFINE\_COS verb contains a variable number of `cos_tg_row` and `cos_node_row` structures; the number of each is specified by the `num_of_node_rows` and `num_of_tg_rows` parameters. The TG rows are included at the end of the main DEFINE\_COS structure, in ascending order of weight; they are followed by the node rows, again in ascending order of weight.

```
typedef struct define_cos
{
    AP_UINT16      opcode;          /* verb operation code      */
    unsigned char  reserv2;        /* reserved                  */
    unsigned char  format;         /* reserved                  */
    AP_UINT16      primary_rc;     /* primary return code      */
    AP_UINT32      secondary_rc;   /* secondary return code    */
    unsigned char  cos_name[8];    /* class of service name    */
    unsigned char  description[32]; /* resource description     */
    unsigned char  reserv1[16];    /* reserved                  */
    unsigned char  transmission_priority; /* transmission priority */
    unsigned char  reserv3[9];     /* reserved                  */
}
```

```

    unsigned char    num_of_node_rows;    /* number of node rows    */
    unsigned char    num_of_tg_rows;     /* number of TG rows      */
} DEFINE_COS;

```

```

typedef struct cos_tg_row
{
    TG_DEFINED_CHARS    minimum;        /* minimum                */
    TG_DEFINED_CHARS    maximum;        /* maximum                */
    unsigned char       weight;         /* weight                 */
    unsigned char       reserv1;        /* reserved               */
} COS_TG_ROW;

```

```

typedef struct tg_defined_chars
{
    unsigned char       effect_cap;     /* effective capacity     */
    unsigned char       reserve1[5];    /* reserved               */
    unsigned char       connect_cost;   /* cost per connect time */
    unsigned char       byte_cost;     /* cost per byte         */
    unsigned char       reserve2;      /* reserved               */
    unsigned char       security;      /* security              */
    unsigned char       prop_delay;    /* propagation delay     */
    unsigned char       modem_class;   /* reserved              */
    unsigned char       user_def_parm_1; /* user defined parameter 1 */
    unsigned char       user_def_parm_2; /* user defined parameter 2 */
    unsigned char       user_def_parm_3; /* user defined parameter 3 */
} TG_DEFINED_CHARS;

```

```

typedef struct cos_node_row
{
    COS_NODE_STATUS    minimum;        /* minimum                */
    COS_NODE_STATUS    maximum;        /* maximum                */
    unsigned char       weight;         /* weight                 */
    unsigned char       reserv1;        /* reserved               */
} COS_NODE_ROW;

```

```

typedef struct cos_node_status
{
    unsigned char       rar;            /* route additional resistance */
    unsigned char       status;         /* node status            */
    unsigned char       reserv1[2];     /* reserved               */
} COS_NODE_STATUS;

```

## Supplied parameters

The application supplies the following parameters:

### ***opcode***

AP\_DEFINE\_COS

### ***cos\_name***

Class of service name. This is an 8-byte alphanumeric type-A EBCDIC string (starting with a letter), padded on the right with EBCDIC spaces.

### ***description***

A null-terminated text string (0-31 characters followed by a null character) describing the COS. This string is for information only; it is stored in the node's configuration file and returned on the QUERY\_COS verb, but CS/AIX does not make any other use of it.

### ***transmission\_priority***

Transmission priority. Possible values are:

AP\_LOW

AP\_MEDIUM

AP\_HIGH

AP\_NETWORK

### ***num\_of\_node\_rows***

Number of node rows which follow the DEFINE\_COS VCB (after the TG rows). The maximum is 8.

***num\_of\_tg\_rows***

Number of TG rows which follow the DEFINE\_COS VCB. The maximum is 8.

Each TG row contains a set of minimum TG characteristics, a set of maximum TG characteristics, and a weight. When computing the weights for a TG, its characteristics are checked against the minimum and maximum characteristics defined for each TG row. The TG is then assigned the weight of the first TG row which bounds all the TG's characteristics within the limits specified. If the TG characteristics do not satisfy any of the listed TG rows, the TG is considered unsuitable for this COS, and is assigned an infinite weight. The TG rows must be concatenated in ascending order of weight.

***cos\_tg\_row.minimum.effect\_cap***

Minimum limit for actual bits per second rate (line speed). The value is encoded as a 1-byte floating point number, represented by the formula  $0.1 \text{ mmm} * 2^{\text{eeeeee}}$  where the bit representation of the byte is `b'eeeeemmm'`. Each unit of effective capacity is equal to 300 bits per second.

***cos\_tg\_row.minimum.connect\_cost***

Minimum limit for cost per connect time. Valid values are integer values in the range 0-255, where 0 is the lowest cost per connect time and 255 is the highest.

***cos\_tg\_row.minimum.byte\_cost***

Minimum limit for cost per byte. Valid values are integer values in the range 0-255, where 0 is the lowest cost per byte and 255 is the highest.

***cos\_tg\_row.minimum.security***

Minimum level of security. Possible values are:

**AP\_SEC\_NONSECURE**

No security.

**AP\_SEC\_PUBLIC\_SWITCHED\_NETWORK**

Data is transmitted over a public switched network.

**AP\_SEC\_UNDERGROUND\_CABLE**

Data is transmitted over secure underground cable.

**AP\_SEC\_SECURE\_CONDUIT**

Data is transmitted over a line in a secure conduit that is not guarded.

**AP\_SEC\_GUARDED\_CONDUIT**

Data is transmitted over a line in a conduit that is protected against physical tapping.

**AP\_SEC\_ENCRYPTED**

Data is encrypted before transmission over the line.

**AP\_SEC\_GUARDED\_RADIATION**

Data is transmitted over a line that is protected against physical and radiation tapping.

***cos\_tg\_row.minimum.prop\_delay***

Minimum limits for propagation delay: the time that a signal takes to travel the length of the link. Specify one of the following values, according to the type of link:

**AP\_PROP\_DELAY\_MINIMUM**

Minimum propagation delay.

**AP\_PROP\_DELAY\_LAN**

Delay is less than 480 microseconds (typical for a LAN).

**AP\_PROP\_DELAY\_TELEPHONE**

Delay is in the range 480-49,512 microseconds (typical for a telephone network).

**AP\_PROP\_DELAY\_PKT\_SWITCHED\_NET**

Delay is in the range 49,512-245,760 microseconds (typical for a packet-switched network).

**AP\_PROP\_DELAY\_SATELLITE**

Delay is greater than 245,760 microseconds (typical for a satellite link).

**AP\_PROP\_DELAY\_MAXIMUM**

Maximum propagation delay.

***cos\_tg\_row.minimum.user\_def\_parm\_1 through cos\_tg\_row.user\_def\_parm\_3***

Minimum values for user-defined parameters, which you can use to include other TG characteristics not covered by the above parameters. Each of these parameters must be set to a value in the range 0-255.

***cos\_tg\_row.maximum.effect\_cap***

Maximum limit for actual bits per second rate (line speed). The value is encoded as a 1-byte floating point number, represented by the formula  $0.1 \text{ mmm} * 2^{\text{eeee}}$  where the bit representation of the byte is b'eeeeemmm'. Each unit of effective capacity is equal to 300 bits per second.

***cos\_tg\_row.maximum.connect\_cost***

Maximum limit for cost per connect time. Valid values are integer values in the range 0-255, where 0 is the lowest cost per connect time and 255 is the highest.

***cos\_tg\_row.maximum.byte\_cost***

Maximum limit for cost per byte. Valid values are integer values in the range 0-255, where 0 is the lowest cost per byte and 255 is the highest.

***cos\_tg\_row.maximum.security***

Maximum level of security. Possible values are:

**AP\_SEC\_NONSECURE**

No security.

**AP\_SEC\_PUBLIC\_SWITCHED\_NETWORK**

Data is transmitted over a public switched network.

**AP\_SEC\_UNDERGROUND\_CABLE**

Data is transmitted over secure underground cable.

**AP\_SEC\_SECURE\_CONDUIT**

Data is transmitted over a line in a secure conduit that is not guarded.

**AP\_SEC\_GUARDED\_CONDUIT**

Data is transmitted over a line in a conduit that is protected against physical tapping.

**AP\_SEC\_ENCRYPTED**

Data is encrypted before transmission over the line.

**AP\_SEC\_GUARDED\_RADIATION**

Data is transmitted over a line that is protected against physical and radiation tapping.

***cos\_tg\_row.maximum.prop\_delay***

Maximum limits for propagation delay: the time that a signal takes to travel the length of the link. Specify one of the following values, according to the type of link:

**AP\_PROP\_DELAY\_MINIMUM**

Minimum propagation delay.

**AP\_PROP\_DELAY\_LAN**

Delay is less than 480 microseconds (typical for a LAN).

**AP\_PROP\_DELAY\_TELEPHONE**

Delay is in the range 480-49,512 microseconds (typical for a telephone network).

**AP\_PROP\_DELAY\_PKT\_SWITCHED\_NET**

Delay is in the range 49,512-245,760 microseconds (typical for a packet-switched network).

**AP\_PROP\_DELAY\_SATELLITE**

Delay is greater than 245,760 microseconds (typical for a satellite link).

**AP\_PROP\_DELAY\_MAXIMUM**

Maximum propagation delay.

***cos\_tg\_row.maximum.user\_def\_parm\_1 through cos\_tg\_row.maximum.user\_def\_parm\_3***

Maximum values for user-defined parameters, which you can use to include other TG characteristics not covered by the above parameters. Each of these parameters must be set to a value in the range 0-255.

***cos\_tg\_row.weight***

Weight associated with this TG row.

## DEFINE\_COS

Each node row contains a set of minimum node characteristics, a set of maximum node characteristics, and a weight. When computing the weights for a node, its characteristics are checked against the minimum and maximum characteristics defined for each node row. The node is then assigned the weight of the first node row which bounds all the node's characteristics within the limits specified. If the node characteristics do not satisfy any of the listed node rows, the node is considered unsuitable for this COS, and is assigned an infinite weight. The node rows must be listed in ascending order of weight.

### ***cos\_node\_row.minimum.rar***

Route additional resistance minimum. Values must be in the range 0-255.

### ***cos\_node\_row.minimum.status***

Specifies the minimum congestion status of the node. Possible values are:

#### **AP\_UNCONGESTED**

The number of ISR sessions is below the *isr\_sessions\_upper\_threshold* value in the node's configuration.

#### **AP\_CONGESTED**

The number of ISR sessions exceeds the threshold value.

### ***cos\_node\_row.maximum.rar***

Route additional resistance maximum. Values must be in the range 0-255.

### ***cos\_node\_row.maximum.status***

Specifies the maximum congestion status of the node. Possible values are:

#### **AP\_UNCONGESTED**

The number of ISR sessions is below the *isr\_sessions\_upper\_threshold* value in the node's configuration.

#### **AP\_CONGESTED**

The number of ISR sessions exceeds the threshold value.

### ***cos\_node\_row.weight***

Weight associated with this node row.

## Returned parameters: successful execution

If the verb executes successfully, CS/AIX returns the following parameters:

### ***primary\_rc***

AP\_OK

## Returned parameters: parameter check

If the verb does not execute because of a parameter error, CS/AIX returns the following parameters:

### ***primary\_rc***

AP\_PARAMETER\_CHECK

### ***secondary\_rc***

Possible values are:

#### **AP\_INVALID\_COS\_NAME**

The *cos\_name* parameter contained a character that was not valid.

#### **AP\_INVALID\_NUMBER\_OF\_NODE\_ROWS**

The *num\_of\_node\_rows* parameter was not in the valid range.

#### **AP\_INVALID\_NUMBER\_OF\_TG\_ROWS**

The *num\_of\_tg\_rows* parameter was not in the valid range.

#### **AP\_NODE\_ROW\_WGT\_LESS\_THAN\_LAST**

The node rows were not listed in ascending order of weight.

#### **AP\_TG\_ROW\_WGT\_LESS\_THAN\_LAST**

The TG rows were not listed in ascending order of weight.

Appendix B, “Common return codes,” on page 661 lists further secondary return codes associated with AP\_PARAMETER\_CHECK, which are common to all NOF verbs.

## Returned parameters: state check

If the verb does not execute because of a state error, CS/AIX returns the following parameters.

### *primary\_rc*

AP\_STATE\_CHECK

### *secondary\_rc*

#### **AP\_COS\_TABLE\_FULL**

You cannot define a new COS because this would exceed the maximum number of COS definitions permitted for the node (specified by the *cos\_cache\_size* parameter on DEFINE\_NODE).

Appendix B, “Common return codes,” on page 661 lists further secondary return codes associated with AP\_STATE\_CHECK, which are common to all NOF verbs.

## Returned parameters: other conditions

Appendix B, “Common return codes,” on page 661 lists further combinations of primary and secondary return codes that are common to all NOF verbs.

## DEFINE\_CPIC\_SIDE\_INFO

This verb adds or replaces a side information entry. A CPI-C side information entry associates a set of conversation characteristics with a symbolic destination name. If there is already a side information entry with the same symbolic destination name as the one supplied with this verb, it is overwritten with the data supplied to this call.

Note the difference between this verb and the CPI-C function Set\_CPIC\_Side\_Information. This verb modifies the domain configuration file, so that it affects all CS/AIX CPI-C applications. The CPI-C function modifies the application's own copy in memory of the side information table, and does not affect any other CPI-C applications.

This verb must be issued to the domain configuration file.

## VCB structure

```
typedef struct define_cplic_side_info
{
    AP_UINT16          opcode;                /* verb operation code      */
    unsigned char     reserv2;                /* reserved                  */
    unsigned char     format;                 /* reserved                  */
    AP_UINT16          primary_rc;            /* primary return code      */
    AP_UINT32          secondary_rc;          /* secondary return code    */
    unsigned char     reserv2a[8];           /* reserved                  */
    unsigned char     sym_dest_name[8];      /* Symbolic destination name */
    CPIC_SIDE_INFO_DEF_DATA def_data;
} DEFINE_CPIC_SIDE_INFO;
```

```
typedef struct cplic_side_info_def_data
{
    unsigned char     description[32];        /* resource description      */
    unsigned char     reserv1[16];           /* reserved                  */
    CPIC_SIDE_INFO    side_info;             /* CPIC side info           */
    unsigned char     user_data[24];         /* reserved                  */
} CPIC_SIDE_INFO_DEF_DATA;
```

```
typedef struct cplic_side_info
{
    unsigned char     partner_lu_name[17];    /* Fully qualified          */
    unsigned char     reserved[3];           /* Reserved                  */
    AP_UINT32          tp_name_type;         /* TP name type             */
}
```

## DEFINE\_CPIC\_SIDE\_INFO

```
unsigned char    tp_name[64];           /* TP name          */
unsigned char    mode_name[8];         /* Mode name        */
AP_UINT32        conversation_security_type; /* Conversation security
                                         /* type            */
unsigned char    security_user_id[10]; /* User ID          */
unsigned char    security_password[10]; /* Password         */
unsigned char    lu_alias[8];         /* LU alias         */
} CPIC_SIDE_INFO;
```

## Supplied parameters

The application supplies the following parameters:

### **opcode**

AP\_DEFINE\_CPIC\_SIDE\_INFO

### **sym\_dest\_name**

Symbolic destination name which identifies the side information entry. This is an 8-byte ASCII string, padded on the right with spaces if necessary. The name can contain any displayable character.

### **def\_data.description**

A null-terminated text string (0-31 characters followed by a null character) describing the side information entry. This string is for information only; it is stored in the configuration file and returned on the QUERY\_CPIC\_SIDE\_INFO verb, but CS/AIX does not make any other use of it.

### **def\_data.side\_info.partner\_lu\_name**

Fully qualified name of the partner LU. The name is a 17-byte EBCDIC string, right-padded with EBCDIC spaces. It consists of a network ID of up to 8 A-string characters, an EBCDIC dot (period) character, and a network name of up to 8 A-string characters.

### **def\_data.side\_info.tp\_name\_type**

The type of the target TP (the valid characters for a TP name are determined by the TP type). Possible values are:

#### **XC\_APPLICATION\_TP**

Application TP. All characters in the TP name must be valid ASCII characters.

#### **XC\_SNA\_SERVICE\_TP**

Service TP. The TP name must be specified as an 8-character ASCII string representing the hexadecimal digits of a 4-character name. For example, if the hexadecimal representation of the name is 0x21F0F0F8, set the *def\_data.side\_info.tp\_name* parameter to the 8-character string '21F0F0F8'.

The first character (represented by two bytes) must be a hexadecimal value in the range 00-3F, excluding 0E and 0F; the remaining characters (each represented by two bytes) must be valid EBCDIC characters.

### **def\_data.side\_info.tp\_name**

TP name of the target TP. This is a 64-byte ASCII character string, padded on the right with ASCII spaces.

### **def\_data.side\_info.mode\_name**

Name of the mode used to access the target TP. This is an 8-byte ASCII character string, padded on the right with spaces.

### **def\_data.side\_info.conversation\_security\_type**

Specifies whether the target TP uses conversation security. Possible values are:

#### **XC\_SECURITY\_NONE**

The target TP does not use conversation security.

#### **XC\_SECURITY\_PROGRAM**

The target TP uses conversation security. The *security\_user\_id* and *security\_password* parameters specified below will be used to access the target TP.



**XC\_SECURITY\_PROGRAM\_STRONG**

As for XC\_SECURITY\_PROGRAM, except that the local node must not send the password across the network in clear text format. This value can be used only if the remote system supports password substitution.

**XC\_SECURITY\_SAME**

The target TP uses conversation security, and can accept an "already verified" indicator from the local TP. (This indicates that the local TP was itself invoked by another TP, and has verified the security user ID and password supplied by this TP.) The *security\_user\_id* parameter specified below will be used to access the target TP; no password is required.

***def\_data.side\_info.security\_user\_id***

User ID used to access the partner TP. This parameter is not required if the *conversation\_security\_type* parameter is set to XC\_SECURITY\_NONE.

***def\_data.side\_info.security\_password***

Password used to access the partner TP. This parameter is required only if the *conversation\_security\_type* parameter is set to XC\_SECURITY\_PROGRAM or XC\_SECURITY\_PROGRAM\_STRONG.

***def\_data.side\_info.lu\_alias***

The alias of the local LU used to communicate with the target TP. This alias is a character string using any locally displayable characters.

**Returned parameters: successful execution**

If the verb executes successfully, CS/AIX returns the following parameters:

***primary\_rc***

AP\_OK

**Returned parameters: parameter check**

If the verb does not execute because of a parameter error, CS/AIX returns the following parameters:

***primary\_rc***

AP\_PARAMETER\_CHECK

***secondary\_rc*****AP\_INVALID\_SYM\_DEST\_NAME**

The *sym\_dest\_name* parameter contained a character that was not valid.

Appendix B, "Common return codes," on page 661 lists further secondary return codes associated with AP\_PARAMETER\_CHECK, which are common to all NOF verbs.

**Returned parameters: other conditions**

Appendix B, "Common return codes," on page 661 lists further combinations of primary and secondary return codes that are common to all NOF verbs.

**DEFINE\_DEFAULT\_PU**

DEFINE\_DEFAULT\_PU specifies which PU is the default for handling CS/AIX management services data. Only one default PU for each node can be defined at any time; a second DEFINE\_DEFAULT\_PU verb for a different PU name overrides the previous definition.

DEFINE\_DEFAULT\_PU enables the user to define, redefine, or modify any field of a default PU. This verb also enables the user to delete the default PU, by specifying a null PU name.

If an application issues the MS API verb TRANSFER\_MS\_DATA without specifying a PU name, then the data is routed to the default PU defined for the local node, and sent on this PU's session with the host SSCP. For more information about TRANSFER\_MS\_DATA, see the *IBM Communications Server for Data Center Deployment on AIX or Linux MS Programmer's Guide*.

## DEFINE\_DEFAULTS

### VCB structure

```
typedef struct define_default_pu
{
    AP_UINT16          opcode;          /* verb operation code    */
    unsigned char     reserv2;         /* reserved                */
    unsigned char     format;          /* reserved                */
    AP_UINT16          primary_rc;     /* primary return code    */
    AP_UINT32          secondary_rc;   /* secondary return code  */
    unsigned char     pu_name[8];     /* PU name                 */
    unsigned char     description[32]; /* resource description    */
    unsigned char     reserv1[16];    /* reserved                */
    unsigned char     reserv3[16];    /* reserved                */
} DEFINE_DEFAULT_PU;
```

### Supplied parameters

The application supplies the following parameters:

#### ***opcode***

AP\_DEFINE\_DEFAULT\_PU

#### ***pu\_name***

Name of the default PU; this must be a PU name defined by a previous DEFINE\_LS verb. This is an 8-byte type-A EBCDIC string (starting with a letter), padded on the right with EBCDIC spaces if necessary.

To delete the default PU, specify all zeros.

#### ***description***

A null-terminated text string (0-31 characters followed by a null character) describing the PU. This string is for information only; it is stored in the node's configuration file and returned on the QUERY\_DEFAULT\_PU verb, but CS/AIX does not make any other use of it.

### Returned parameters: successful execution

If the verb executes successfully, CS/AIX returns the following parameters:

#### ***primary\_rc***

AP\_OK

### Returned parameters: other conditions

Appendix B, “Common return codes,” on page 661 lists further combinations of primary and secondary return codes that are common to all NOF verbs.

## DEFINE\_DEFAULTS

DEFINE\_DEFAULTS specifies default parameters used by the node.

### VCB structure

```
typedef struct define_defaults
{
    AP_UINT16          opcode;          /* verb operation code    */
    unsigned char     reserv2;         /* reserved                */
    unsigned char     format;          /* reserved                */
    AP_UINT16          primary_rc;     /* primary return code    */
    AP_UINT32          secondary_rc;   /* secondary return code  */
    DEFAULT_CHARS     default_chars;   /* default parameters     */
} DEFINE_DEFAULTS;
```

```
typedef struct default_chars
{
    unsigned char     description[32]; /* resource description    */
    unsigned char     reserv2[16];    /* reserved                */
}
```

```

unsigned char mode_name[8]; /* default mode name */
unsigned char implicit_plu_forbidden; /* disallow implicit PLUs? */
unsigned char specific_security_codes; /* generic security sense */
/* codes? */
AP_UINT16 limited_timeout; /* timeout for limited sessions*/
unsigned char reserv[244]; /* reserved */
} DEFAULT_CHARS;

```

## Supplied parameters

The application supplies the following parameters:

### ***opcode***

AP\_DEFINE\_DEFAULTS

### ***default\_chars.description***

A null-terminated text string (0-31 characters followed by a null character) describing the default parameters. This string is for information only; it is stored in the node's configuration file and returned on the QUERY\_DEFAULTS verb, but CS/AIX does not make any other use of it.

### ***default\_chars.mode\_name***

Name of the default mode. If an application specifies an unrecognized mode name when attempting to start a session, the parameters from this mode will be used as a default definition for the unrecognized mode.

This must be either a mode defined by a previous DEFINE\_MODE verb or one of the SNA-defined modes listed in “Purpose of the NOF API” on page 1. The name is an 8-byte type-A EBCDIC string (starting with a letter), padded on the right with EBCDIC spaces if necessary.

### ***default\_chars.implicit\_plu\_forbidden***

Specifies whether CS/AIX puts implicit definitions in place for unknown partner LUs. Possible values are:

#### **AP\_YES**

CS/AIX does not put implicit definitions in place for unknown partner LUs. All partner LUs must be defined explicitly.

#### **AP\_NO**

CS/AIX puts implicit definitions in place for unknown partner LUs.

### ***default\_chars.specific\_security\_codes***

Specifies whether CS/AIX uses specific sense codes on a security authentication or authorization failure. Specific sense codes are only returned to those partner LUs which have reported support for them on the session. Possible values are:

#### **AP\_YES**

CS/AIX uses specific sense codes.

#### **AP\_NO**

CS/AIX does not use specific sense codes.

### ***default\_chars.limited\_timeout***

Specifies the timeout after which free limited-resource conwinner sessions are deactivated. Specify a value in the range 0-65,535 seconds.

## Returned parameters: successful execution

If the verb executes successfully, CS/AIX returns the following parameters:

### ***primary\_rc***

AP\_OK

## Returned parameters: parameter check

If the verb does not execute because of a parameter error, CS/AIX returns the following parameters:

## DEFINE\_DIRECTORY\_ENTRY

### *primary\_rc*

AP\_PARAMETER\_CHECK

### *secondary\_rc*

#### **AP\_INVALID\_MODE\_NAME**

The *mode\_name* parameter did not match any defined mode name.

Appendix B, "Common return codes," on page 661 lists further secondary return codes associated with AP\_PARAMETER\_CHECK, which are common to all NOF verbs.

## Returned parameters: other conditions

Appendix B, "Common return codes," on page 661 lists further combinations of primary and secondary return codes that are common to all NOF verbs.

## DEFINE\_DIRECTORY\_ENTRY

DEFINE\_DIRECTORY\_ENTRY defines a new entry in the node directory database. This verb cannot be used to modify existing entries. The verb provides a network qualified resource name along with a resource type (network node, end node, LU or Wildcard).

When defining an adjacent node and its LUs, you are recommended to use DEFINE\_ADJACENT\_LEN\_NODE instead of DEFINE\_DIRECTORY\_ENTRY. This allows you to define the node and its LUs with a single verb. (DEFINE\_DIRECTORY\_ENTRY defines only a single entry, so you need to use multiple verbs to define entries for the adjacent node and for its LUs.)

Because the database is hierarchical, each entry includes the name of the parent resource; for an LU the parent resource is the owning Control Point, and for an end node or LEN node it is the network node server. However, when DEFINE\_DIRECTORY\_ENTRY is used on an end node or LEN node to define an adjacent LEN node resource with which it communicates directly, the entry does not include a parent resource name.

You can specify a "wildcard" LU name to match multiple LU names, by specifying only the initial characters of the name. For example, the wildcard LU name APPN.LU will match APPN.LUNAME or APPN.LU01 (but will not match APPN.NAME LU).

## VCB structure

```
typedef struct define_directory_entry
{
    AP_UINT16      opcode;           /* verb operation code          */
    unsigned char  reserv2;         /* reserved                     */
    unsigned char  format;         /* reserved                     */
    AP_UINT16      primary_rc;     /* primary return code          */
    AP_UINT32      secondary_rc;   /* secondary return code        */
    unsigned char  resource_name[17]; /* network qualified resource name */
    unsigned char  reserv1a;       /* reserved                     */
    AP_UINT16      resource_type;   /* resource type                */
    unsigned char  description[32]; /* resource description         */
    unsigned char  reserv3[16];    /* reserved                     */
    unsigned char  parent_name[17]; /* fully qualified parent name  */
    unsigned char  reserv1b;       /* reserved                     */
    AP_UINT16      parent_type;    /* parent's resource type       */
    unsigned char  reserv4[8];     /* reserved                     */
} DEFINE_DIRECTORY_ENTRY;
```

## Supplied parameters

The application supplies the following parameters:

### *opcode*

AP\_DEFINE\_DIRECTORY\_ENTRY

**resource\_name**

Fully qualified name of the resource being registered. The name is a 17-byte EBCDIC string, right-padded with EBCDIC spaces. It consists of a network ID of up to 8 A-string characters, an EBCDIC dot (period) character, and a network name of up to 8 A-string characters.

**resource\_type**

Specifies the type of the resource being defined. Possible values are:

**AP\_ENCP\_RESOURCE**

End node or LEN node

**AP\_NNCP\_RESOURCE**

Network node

**AP\_LU\_RESOURCE**

LU

**AP\_WILDCARD\_LU\_RESOURCE**

Wildcard LU name.

For an LU or wildcard LU, the directory entry for the parent resource (the owning CP) must already be defined.

**description**

A null-terminated text string (0-31 characters followed by a null character) describing the directory entry. This string is for information only; it is stored in the node's configuration file and returned on the QUERY\_DIRECTORY\_ENTRY and QUERY\_DIRECTORY\_LU verbs, but CS/AIX does not make any other use of it.

**parent\_name**

Fully qualified name of the parent resource; for an LU the parent resource is the owning Control Point, and for an end node or LEN node it is the network node server. The name is a 17-byte EBCDIC string, right-padded with EBCDIC spaces. It consists of a network ID of up to 8 A-string characters, an EBCDIC dot (period) character, and a network name of up to 8 A-string characters.

This parameter should be set to all binary zeros in the following cases:

- When registering a network node CP
- When the verb is being issued to an end node or LEN node to define an adjacent LEN node CP with which the local node communicates directly.

**parent\_type**

Specifies the parent type of the resource being defined. Possible values are:

**AP\_ENCP\_RESOURCE**

End node (for an LU resource owned by an end node)

**AP\_NNCP\_RESOURCE**

Network node (for an LU resource owned by a network node, or for an EN or LEN resource).

Set this parameter to zero when no parent resource name is supplied.

**Returned parameters: successful execution**

If the verb executes successfully, CS/AIX returns the following parameters:

**primary\_rc**

AP\_OK

**Returned parameters: parameter check**

If the verb does not execute because of a parameter error, CS/AIX returns the following parameters:

**primary\_rc**

AP\_PARAMETER\_CHECK

## DEFINE\_DLC

### *secondary\_rc*

Possible values are:

#### **AP\_INVALID\_FQ\_OWNING\_CP\_NAME**

The *parent\_name* parameter did not match the name of a defined resource.

#### **AP\_INVALID\_LU\_NAME**

The *resource\_name* parameter contained a character that was not valid or was not in the correct format.

#### **AP\_INVALID\_RESOURCE\_TYPE**

The *resource\_type* parameter was not set to a valid value.

#### **AP\_INVALID\_WILDCARD\_NAME**

The *resource\_type* parameter was set to AP\_WILDCARD\_LU\_RESOURCE, but the *resource\_name* parameter did not contain a valid wildcard entry.

#### **AP\_DUPLICATE**

The *resource\_name* parameter contained a wildcard entry that has already been defined.

#### **AP\_INVALID\_RESOURCE\_NAME**

The *resource\_name* parameter specified a node name that clashed with the name of the node to which the verb was issued.

Appendix B, “Common return codes,” on page 661 lists further secondary return codes associated with AP\_PARAMETER\_CHECK, which are common to all NOF verbs.

## Returned parameters: other conditions

Appendix B, “Common return codes,” on page 661 lists further combinations of primary and secondary return codes that are common to all NOF verbs.

## DEFINE\_DLC

DEFINE\_DLC defines a new DLC. It can also be used to modify the DLC-specific parameters of an existing DLC, if the DLC is not currently active, but other parameters (such as DLC type, negotiable link support and the valid port types) cannot be modified.

## VCB structure

```
typedef struct define_dlc
{
    AP_UINT16      opcode;                /* verb operation code          */
    unsigned char  reserv2;               /* reserved                      */
    unsigned char  format;                /* reserved                      */
    AP_UINT16      primary_rc;            /* primary return code          */
    AP_UINT32      secondary_rc;          /* secondary return code        */
    unsigned char  dlc_name[8];           /* name of DLC                  */
    DLC_DEF_DATA  def_data;               /* DLC defined data             */
} DEFINE_DLC;
```

```
typedef struct dlc_def_data
{
    unsigned char  description[32];        /* resource description          */
    unsigned char  initially_active;       /* is the DLC initially active? */
    unsigned char  reserv1[15];           /* reserved                      */
    unsigned char  dlc_type;               /* DLC type                      */
    unsigned char  neg_ls_supp;           /* negotiable link station support */
    unsigned char  port_types;            /* port types supported by DLC type */
    unsigned char  hpr_only;              /* only support HPR?            */
    unsigned char  reserv3;               /* reserved                      */
    unsigned char  retry_flags;           /* reserved                      */
    AP_UINT16      max_activation_attempts; /* reserved                      */
    AP_UINT16      activation_delay_timer; /* reserved                      */
    unsigned char  reserv4[4];            /* reserved                      */
    AP_UINT16      dlc_spec_data_len;      /* Length of DLC specific data  */
} DLC_DEF_DATA;
```

DLC-specific data for Token Ring, Ethernet, SDLC, QLLC:

```
typedef struct gdlc_dlc_cfg
{
    V0_MUX_INFO    mux_info;           /* Streams config info          */
    unsigned char  device[16];        /* GDLC device driver name      */
    AP_UINT16      max_saps;          /* Maximum number of SAPS supported */
                                        /* by this DLC                   */

    union
    {
        struct
        {
            AP_UINT16      support_level; /* adapter CCITT level (1980/1984) */
        } x25;
        struct
        {
            unsigned char  ethernet_type; /* Standard Ethernet or IEEE 802.3 */
        } ether;
    } uu;
} GDLC_DLC_CFG;
```

DLC-specific data for Enterprise Extender (HPR/IP):

```
typedef struct ipdlc_dlc_spec_data
{
    V0_MUX_INFO    mux_info;           /* streams information          */
    AP_UINT16      udp_port[5];        /* UDP port numbers for traffic */
                                        /* priorities LLC, Network, High, */
                                        /* Medium, Low                   */
    unsigned char  ip_precedence[5];    /* IP precedence 0-7 for traffic */
                                        /* priorities                     */
    unsigned char  no_dns_lookup;       /* are all remote hosts specified by */
                                        /* numeric IP address?           */
} IPDLC_DLC_SPEC_DATA;
```

For all DLC types:

```
typedef struct v0_mux_info
{
    AP_UINT16      dlc_type;           /* DLC implementation type      */
    unsigned char  need_vrfy_fixup;    /* reserved                      */
    unsigned char  num_mux_ids;        /* reserved                      */
    AP_UINT32      card_type;          /* type of adapter card         */
    AP_UINT32      adapter_number;     /* DLC adapter number           */
    AP_UINT32      oem_data_length;    /* reserved                      */
    AP_INT32       mux_ids[5];         /* reserved                      */
} V0_MUX_INFO;
```

## Supplied parameters

The application supplies the following parameters:

### ***opcode***

AP\_DEFINE\_DLC

### ***dlc\_name***

Name of the DLC. This is an 8-byte ASCII string, using any locally displayable characters, padded on the right with spaces if the name is shorter than 8 bytes.

### ***def\_data.description***

A null-terminated text string (0-31 characters followed by a null character) describing the DLC. This string is for information only; it is stored in the node's configuration file and returned on the QUERY\_DLC verb, but CS/AIX does not make any other use of it.

### ***def\_data.initially\_active***

Specifies whether this DLC is automatically started when the node is started. Possible values are:

#### **AP\_YES**

The DLC is automatically started when the node is started.

## DEFINE\_DLC

### **AP\_NO**

The DLC is automatically started only if a port or LS that uses it is defined to be initially active; otherwise it must be started manually.

### ***def\_data.dlc\_type***

Type of the DLC. You cannot change this parameter for an existing DLC; this parameter can be specified only when creating a new DLC. Possible values are:

#### **AP\_SDLC**

SDLC

#### **AP\_X25**

QLLC

#### **AP\_TR**

Token Ring

#### **AP\_ETHERNET**

Ethernet

#### **AP\_IP**

Enterprise Extender (HPR/IP)

### ***def\_data.neg\_ls\_supp***

Specifies whether the DLC supports negotiable link stations. You cannot change this parameter for an existing DLC; this parameter can be specified only when creating a new DLC. If *dlc\_type* is set to AP\_QLLC, this must be set to AP\_YES.

Possible values are:

#### **AP\_YES**

Link stations using this DLC may be negotiable.

#### **AP\_NO**

Link stations using this DLC must be defined as either primary or secondary; negotiable link stations are not supported.

### ***def\_data.port\_types***

If *dlc\_type* is set to AP\_TR / AP\_ETHERNET / AP\_IP, set this parameter to AP\_PORT\_SATF. For all other DLC types, this parameter is reserved.

### ***def\_data.hpr\_only***

Specifies whether the DLC supports only HPR traffic. If *dlc\_type* is set to AP\_IP, this must be set to AP\_YES. Possible values are:

#### **AP\_YES**

This DLC is used for Enterprise Extender links, and supports only HPR traffic.

#### **AP\_NO**

This DLC is used for link types other than Enterprise Extender and supports non-HPR traffic; it may also support HPR traffic.

### ***def\_data.dlc\_spec\_data\_len***

Length, in bytes, of data specific to the type of the DLC. The DLC-specific data structures should be included at the end of the basic VCB structure.

DLC-specific data for Token Ring, Ethernet, SDLC, QLLC:

### ***gdlc\_dlc\_cfg.mux\_info.dlc\_type***

Type of the DLC. Possible values are:

#### **AP\_IMPL\_TR\_GDLC**

Token Ring

#### **AP\_IMPL\_ETHER\_GDLC**

Ethernet

#### **AP\_IMPL\_X25\_GDLC**

QLLC



**AP\_IMPL\_SDLC\_GDLC**

SDLC

***gdlc\_dlc\_cfg.mux\_info.card\_type***

Type of the adapter card. Possible values are:

**AP\_CARD\_GDLC\_TOKEN\_RING**

Token Ring

**AP\_CARD\_GDLC\_ETHERNET**

Ethernet

**AP\_CARD\_GDLC\_QLLC**

QLLC

**AP\_CARD\_GDLC\_SDLC**

SDLC

***gdlc\_dlc\_cfg.mux\_info.adapter\_number***

Adapter number used by the DLC. If the server contains more than one adapter card for this DLC type, specify zero for the first card, 1 for the second, and so on. Otherwise, set this parameter to zero.

***gdlc\_dlc\_cfg.device***

Name of the GDLC device driver. This is an ASCII string of 1-15 characters, terminated by a null character.

***gdlc\_dlc\_cfg.max\_saps***

Maximum number of SAPs that this DLC can support.

For QLLC:

***gdlc\_dlc\_cfg.uu.x25.support\_level***

X.25 support level provided by the adapter. Possible values are:

**AP\_1980**

1980 standard

**AP\_1984**

1984 standard

**AP\_1988**

1988 standard

For Ethernet:

***gdlc\_dlc\_cfg.uu.ether.ethernet\_type***

Type of Ethernet network. Possible values are:

**GDLC\_ETHER\_STANDARD**

Standard Ethernet

**GDLC\_ETHER\_8023**

IEEE 802.3

DLC-specific data for Channel:

***chnl\_dlc\_spec\_data.mux\_info.dlc\_type***

Type of the DLC. Set this to AP\_CHANNEL.

***chnl\_dlc\_spec\_data.mux\_info.card\_type***

Type of the adapter card. Possible values are:

**AP\_CARD\_IBM\_ESCON**

AIX Enterprise System Connection Adapter.

**AP\_CARD\_BLK\_MUX**

AIX Block Multiplexer Channel Adapter.

***chnl\_dlc\_spec\_data.mux\_info.adapter\_number***

This parameter is reserved (set it to zero).

DLC-specific data for Enterprise Extender (HPR/IP):

## DEFINE\_DLC

### ***ipdlc\_dlc\_spec\_data.mux\_info.dlc\_type***

Type of the DLC. Set this to AP\_IP.

### ***ipdlc\_dlc\_spec\_data.mux\_info.card\_type***

Type of the adapter card. Set this to AP\_CARD\_IP.

### ***ipdlc\_dlc\_spec\_data.mux\_info.adapter\_number***

Reserved (set this parameter to zero).

### ***ipdlc\_dlc\_spec\_data.udp\_port***

Array of five UDP port numbers used by the DLC for different traffic priorities. These are normally set to 12000 - 12004.

#### ***udp\_port[0]***

UDP port used for LLC commands.

#### ***udp\_port[1]***

UDP port used for network priority traffic.

#### ***udp\_port[2]***

UDP port used for high priority traffic.

#### ***udp\_port[3]***

UDP port used for medium priority traffic.

#### ***udp\_port[4]***

UDP port used for low priority traffic.

### ***ipdlc\_dlc\_spec\_data.ip\_precedence***

Array of five IP precedence values used by the DLC for different traffic priorities. Each entry in this array is a value in the range 0 (minimum) - 7 (maximum).

#### ***ip\_precedence[0]***

IP precedence used for LLC commands. This is normally set to 6.

#### ***ip\_precedence[1]***

IP precedence used for network priority traffic. This is normally set to 6.

#### ***ip\_precedence[2]***

IP precedence used for high priority traffic. This is normally set to 4.

#### ***ip\_precedence[3]***

IP precedence used for medium priority traffic. This is normally set to 2.

#### ***ip\_precedence[4]***

IP precedence used for low priority traffic. This is normally set to 1.

### ***ipdlc\_dlc\_spec\_data.no\_dns\_lookup***

Specifies whether remote host IP addresses require lookup at a Domain Name Server. Possible values are:

#### **AP\_YES**

Do not attempt to look up the hostname from the remote IP address when receiving an incoming IP connection.

Use this option when the remote IP address cannot be resolved. In this case, the incoming connection can be matched to a configured LS only if the LS is configured to use an explicit IP address (either IPv4 or IPv6) rather than a hostname.

#### **AP\_NO**

The remote host IP address on link stations defined for this DLC can be specified as a numeric address (either IPv4 or IPv6), as a name (such as `newbox.this.co.uk`), or as an alias (such as `newbox`). The node performs a Domain Name Server lookup to determine the remote host name on all incoming calls where necessary.

## Returned parameters: successful execution

If the verb executes successfully, CS/AIX returns the following parameters:

**primary\_rc**

AP\_OK

**Returned parameters: parameter check**

If the verb does not execute because of a parameter error, CS/AIX returns the following parameters:

**primary\_rc**

AP\_PARAMETER\_CHECK

**secondary\_rc**

Possible values are:

**AP\_INVALID\_DLC\_NAME**

The supplied *dlc\_name* parameter contained a character that was not valid.

**AP\_INVALID\_DLC\_TYPE**

The supplied *dlc\_type* parameter was not one of the allowed values.

Appendix B, “Common return codes,” on page 661 lists further secondary return codes associated with AP\_PARAMETER\_CHECK, which are common to all NOF verbs.

**Returned parameters: state check**

If the verb does not execute because of a state error, CS/AIX returns the following parameters.

**primary\_rc**

AP\_STATE\_CHECK

**secondary\_rc**

Possible values are:

**AP\_DLC\_ACTIVE**

The specified DLC cannot be modified because it is currently active.

**AP\_INVALID\_DLC\_TYPE**

You cannot change the DLC type, negotiable link support, or supported port types for an existing DLC. They can be specified only when creating a new DLC.

Appendix B, “Common return codes,” on page 661 lists further secondary return codes associated with AP\_STATE\_CHECK, which are common to all NOF verbs.

**Returned parameters: other conditions**

Appendix B, “Common return codes,” on page 661 lists further combinations of primary and secondary return codes that are common to all NOF verbs.

**DEFINE\_DLUR\_DEFAULTS**

DEFINE\_DLUR\_DEFAULTS defines a default Dependent LU server (DLUS) and a backup default DLUS; if a default DLUS or backup default DLUS is already defined, the verb overrides the existing definition. The default DLUS name is used by DLUR when it initiates SSCP-PU activation for PUs that do not have an explicitly specified associated DLUS. (To define a PU and its associated DLUS, use DEFINE\_INTERNAL\_PU for a local PU, or DEFINE\_LS for a downstream PU.)

The verb can also be used to revoke a default DLUS or backup default DLUS, so that none is defined.

**VCB structure**

```
typedef struct define_dlur_defaults
{
    AP_UINT16      opcode;                /* verb operation code          */
    unsigned char  reserv2;              /* reserved                      */
    unsigned char  format;               /* reserved                      */
    AP_UINT16      primary_rc;           /* primary return code          */
    AP_UINT32      secondary_rc;         /* secondary return code        */
}
```

## DEFINE\_DLUR\_DEFAULTS

```
unsigned char  description[32];          /* resource description      */
unsigned char  reserv1[16];             /* reserved                  */
unsigned char  dlus_name[17];          /* DLUS name                 */
unsigned char  bkup_dlus_name[17];     /* Backup DLUS name         */
unsigned char  reserv3;                /* reserved                  */
unsigned char  dlus_retry_timeout;     /* retry timeout            */
unsigned char  dlus_retry_limit;       /* retry limit              */
unsigned char  prefer_active_dlus;     /* reserved                  */
unsigned char  persistent_pipe_support; /* reserved                  */
unsigned char  reserv4[14];            /* reserved                  */
} DEFINE_DLUR_DEFAULTS;
```

## Supplied parameters

The application supplies the following parameters:

### **opcode**

AP\_DEFINE\_DLUR\_DEFAULTS

### **description**

A null-terminated text string (0-31 characters followed by a null character) describing the DLUR defaults. This string is for information only; it is stored in the node's configuration file, but CS/AIX does not make any other use of it.

### **dlus\_name**

Name of DLUS node which will serve as the default. The name is a 17-byte EBCDIC string, right-padded with EBCDIC spaces. It consists of a network ID of up to 8 A-string characters, an EBCDIC dot (period) character, and a network name of up to 8 A-string characters.

To revoke the current default DLUS, so that no default DLUS is defined, set this parameter to 17 binary zeros.

### **bkup\_dlus\_name**

Name of DLUS node which will serve as the backup default. The name is a 17-byte EBCDIC string, right-padded with EBCDIC spaces. It consists of a network ID of up to 8 A-string characters, an EBCDIC dot (period) character, and a network name of up to 8 A-string characters.

To revoke the current backup default DLUS, so that no backup default DLUS is defined, set this parameter to 17 binary zeros.

### **dlus\_retry\_timeout**

Reactivation timer for contacting a DLUS. If CS/AIX fails to contact the DLUS, this parameter specifies the time in seconds between retries. Specify a value in the range 0x0001-0xFFFF.

### **dlus\_retry\_limit**

Retry count for contacting a DLUS. This parameter is used to specify the number of times CS/AIX should retry if it fails to contact the DLUS on the first attempt.

Specify a value in the range 0x0001-0xFFFE, or 0xFFFF to indicate that CS/AIX should retry indefinitely until it contacts the DLUS.

## Returned parameters: successful execution

If the verb executes successfully, CS/AIX returns the following parameters:

### **primary\_rc**

AP\_OK

## Returned parameters: parameter check

If the verb does not execute because of a parameter error, CS/AIX returns the following parameters:

### **primary\_rc**

AP\_PARAMETER\_CHECK

### **secondary\_rc**

Possible values are:

**AP\_INVALID\_DLUS\_NAME**

The supplied *dlus\_name* parameter contained a character that was not valid or was not in the correct format.

**AP\_INVALID\_BKUP\_DLUS\_NAME**

The supplied *dlus\_name* parameter contained a character that was not valid or was not in the correct format.

Appendix B, “Common return codes,” on page 661 lists further secondary return codes associated with AP\_PARAMETER\_CHECK, which are common to all NOF verbs.

**Returned parameters: function not supported**

If the verb does not execute successfully because the local node's configuration does not support it, CS/AIX returns the following parameters:

**primary\_rc****AP\_FUNCTION\_NOT\_SUPPORTED**

The local node does not support DLUR; this is defined by the *dlur\_support* parameter on the DEFINE\_NODE verb.

**Returned parameters: other conditions**

Appendix B, “Common return codes,” on page 661 lists further combinations of primary and secondary return codes that are common to all NOF verbs.

**DEFINE\_DOMAIN\_CONFIG\_FILE**

DEFINE\_DOMAIN\_CONFIG\_FILE specifies a comment string to be included in the header of the domain configuration file, or modifies an existing comment string.

There is no equivalent verb for a node configuration file, because the header for this file does not contain a comment string; use the description parameter in the DEFINE\_NODE verb to include comment information in a node configuration file.

This verb must be issued to the domain configuration file.

**VCB structure**

```
typedef struct define_domain_config_file
{
    AP_UINT16          opcode;                /* verb operation code      */
    unsigned char     reserv2;               /* reserved                 */
    unsigned char     format;               /* reserved                 */
    AP_UINT16          primary_rc;          /* primary return code     */
    AP_UINT32          secondary_rc;        /* secondary return code   */
    unsigned char     reserv3[8];          /* Reserved                 */
    CONFIG_FILE_HEADER hdr;                /* defined data            */
} DEFINE_DOMAIN_CONFIG_FILE;
```

```
typedef struct config_file_header
{
    AP_UINT16          major_version;        /* reserved                 */
    AP_UINT16          minor_version;        /* reserved                 */
    AP_UINT16          update_release;       /* reserved                 */
    AP_UINT32          revision_level;       /* reserved                 */
    unsigned char     comment[100];         /* optional comment string */
    unsigned char     updating;             /* reserved                 */
} CONFIG_FILE_HEADER;
```

**Supplied parameters**

The application supplies the following parameters:

## DEFINE\_DOWNSTREAM\_LU

### *opcode*

AP\_DEFINE\_DOMAIN\_CONFIG\_FILE

### *hdr.comment*

An optional comment string to store information about the file. This is an ASCII string of 0-99 characters, followed by a null character. This parameter is for information only; CS/AIX returns it on the QUERY\_DOMAIN\_CONFIG\_FILE verb, but does not make any other use of it.

## Returned parameters: successful execution

If the verb executes successfully, CS/AIX returns the following parameters:

### *primary\_rc*

AP\_OK

## Returned parameters: other conditions

Appendix B, “Common return codes,” on [page 661](#) lists further combinations of primary and secondary return codes that are common to all NOF verbs.

## DEFINE\_DOWNSTREAM\_LU

---

DEFINE\_DOWNSTREAM\_LU defines a new downstream LU, and maps it to an upstream host LU or LU pool (defined using DEFINE\_LU\_0\_TO\_3 or DEFINE\_LU\_POOL). This allows the downstream LU to access the host computer using the SNA gateway feature of CS/AIX. This verb cannot be used to modify an existing downstream LU.

This verb can also be used to activate a downstream LU that is already defined (for example, because the downstream workstation has just been activated). To do this, reissue the DEFINE\_DOWNSTREAM\_LU verb for that LU. Note that all parameters must be the same as in the original definition, because you cannot modify the definition.

DEFINE\_DOWNSTREAM\_LU can also be used to define the downstream LU used by an application that communicates with a CS/AIX Primary RUI application. For more information about Primary RUI, see IBM Communications Server for Data Center Deployment on AIX or Linux LUA Programmer's Guide.

## VCB structure

```
typedef struct define_downstream_lu
{
    AP_UINT16          opcode;          /* verb operation code      */
    unsigned char     reserv2;         /* reserved                 */
    unsigned char     format;         /* reserved                 */
    AP_UINT16          primary_rc;     /* primary return code     */
    AP_UINT32          secondary_rc;   /* secondary return code   */
    unsigned char     dslu_name[8];    /* Downstream LU name     */
    DOWNSTREAM_LU_DEF_DATA def_data;   /* Defined data           */
} DEFINE_DOWNSTREAM_LU;
```

```
typedef struct downstream_lu_def_data
{
    unsigned char     description[32]; /* resource description     */
    unsigned char     reserv1[16];    /* reserved                 */
    unsigned char     nau_address;    /* downstream LU nau address */
    unsigned char     dspu_name[8];   /* Downstream PU name     */
    unsigned char     host_lu_name[8]; /* Host LU or Pool name   */
    unsigned char     allow_timeout;  /* Allow timeout of host LU? */
    unsigned char     delayed_logon;  /* Allow delayed logon to  */
    unsigned char     host_lu;        /* host LU                 */
    unsigned char     reserv2[6];     /* reserved                 */
} DOWNSTREAM_LU_DEF_DATA;
```

## Supplied parameters

The application supplies the following parameters:

**opcode**

AP\_DEFINE\_DOWNSTREAM\_LU

**dslu\_name**

Name of the downstream LU that is being defined. This is an 8-byte type-A EBCDIC string (starting with a letter), padded on the right with EBCDIC spaces.

**def\_data.description**

A null-terminated text string (0-31 characters followed by a null character) describing the downstream LU. This string is for information only; it is stored in the node's configuration file and returned on the QUERY\_DOWNSTREAM\_LU verb, but CS/AIX does not make any other use of it.

**def\_data.nau\_address**

Network accessible unit address of the downstream LU. This must be in the range 1-255.

**def\_data.dspu\_name**

Name of the downstream PU associated with this LU (as specified on the DEFINE\_LS). This is an 8-byte type-A EBCDIC string (starting with a letter), padded on the right with EBCDIC spaces.

**def\_data.host\_lu\_name**

Name of the host LU or host LU pool that the downstream LU will be mapped onto. This is an 8-byte type-A EBCDIC string, padded on the right with EBCDIC spaces.

For SNA gateway, the host LU cannot be a dependent LU type 6.2. However, if the downstream LU is LU type 6.2, you can configure the host LU as an LU type 0-3 and specify that the model type for the host LU is unknown.

If the downstream LU is used to communicate with a CS/AIX Primary RUI application instead of a host, set this field to the string #PRIRUI# in EBCDIC.

**def\_data.allow\_timeout**

Specifies whether to allow the session between the downstream LU and the upstream LU to timeout if the session is left inactive for the timeout period specified on the upstream LU definition. Possible values are:

**AP\_YES**

Allow the session this downstream LU has with the upstream LU to timeout.

**AP\_NO**

Do not allow the session this downstream LU has with the upstream LU to timeout.

This field is ignored if the downstream LU is used to communicate with a CS/AIX Primary RUI application instead of a host.

**def\_data.delayed\_logon**

Specifies whether to use delayed logon with this downstream LU (the upstream LU is not activated until the user requests it). Possible values are:

**AP\_YES**

Use delayed logon with this downstream LU; the upstream LU is not activated until the user requests it.

**AP\_NO**

Do not use delayed logon with this downstream LU.

This field is ignored if the downstream LU is used to communicate with a CS/AIX Primary RUI application instead of a host.

**Returned parameters: successful execution**

If the verb executes successfully, CS/AIX returns the following parameters:

**primary\_rc**

AP\_OK

## Returned parameters: parameter check

If the verb does not execute because of a parameter error, CS/AIX returns the following parameters:

### **primary\_rc**

AP\_PARAMETER\_CHECK

### **secondary\_rc**

Possible values are:

#### **AP\_INVALID\_DNST\_LU\_NAME**

The supplied *dslu\_name* parameter contained a character that was not valid.

#### **AP\_INVALID\_NAU\_ADDRESS**

The supplied NAU address was not in the valid range.

#### **AP\_INVALID\_ALLOW\_TIMEOUT**

The supplied *allow\_timeout* parameter value was not valid.

#### **AP\_INVALID\_DELAYED\_LOGON**

The supplied *delayed\_logon* parameter value was not valid.

Appendix B, "Common return codes," on page 661 lists further secondary return codes associated with AP\_PARAMETER\_CHECK, which are common to all NOF verbs.

## Returned parameters: state check

If the verb does not execute because of a state error, CS/AIX returns the following parameters.

### **primary\_rc**

AP\_STATE\_CHECK

### **secondary\_rc**

Possible values are:

#### **AP\_INVALID\_PU\_NAME**

The specified *dspu\_name* parameter was not valid.

#### **AP\_PU\_NOT\_DEFINED**

The specified *dspu\_name* parameter did not match any defined PU name.

#### **AP\_INVALID\_PU\_TYPE**

The PU specified by the *dspu\_name* parameter is not a downstream PU that supports SNA gateway.

#### **AP\_LU\_ALREADY\_DEFINED**

An LU with the specified name has already been defined, and cannot be modified using this verb.

#### **AP\_DSLU\_ACTIVE**

The LU is already active.

#### **AP\_LU\_NAU\_ADDR\_ALREADY\_DEFD**

An LU with the specified NAU address has already been defined.

#### **AP\_INVALID\_HOST\_LU\_NAME**

The specified host LU name was not valid.

#### **AP\_LU\_NAME\_POOL\_NAME\_CLASH**

The specified LU name clashes with the name of an existing LU pool.

#### **AP\_PU\_NOT\_ACTIVE**

The PU specified by the *dspu\_name* parameter is not currently active.

#### **AP\_LU\_ALREADY\_ACTIVATING**

An LU with the name specified by the *dslu\_name* parameter is currently activating.

#### **AP\_LU\_DEACTIVATING**

An LU with the name specified by the *dslu\_name* parameter is currently deactivating.

#### **AP\_LU\_ALREADY\_ACTIVE**

An LU with the name specified by the *dslu\_name* parameter is already active.



Appendix B, “Common return codes,” on page 661 lists further secondary return codes associated with AP\_STATE\_CHECK, which are common to all NOF verbs.

## Returned parameters: function not supported

If the verb does not execute successfully because the local node's configuration does not support it, CS/AIX returns the following parameters:

### *primary\_rc*

#### **AP\_FUNCTION\_NOT\_SUPPORTED**

The local node does not support SNA gateway; this is defined by the *pu\_conc\_support* parameter on the DEFINE\_NODE verb.

## Returned parameters: other conditions

Appendix B, “Common return codes,” on page 661 lists further combinations of primary and secondary return codes that are common to all NOF verbs.

## DEFINE\_DOWNSTREAM\_LU\_RANGE

DEFINE\_DOWNSTREAM\_LU\_RANGE defines a new range of downstream LUs, and maps them to an upstream host LU or LU pool (defined using DEFINE\_LU\_0\_TO\_3 or DEFINE\_LU\_POOL). This allows the downstream LUs to access the host computer using the SNA gateway feature of CS/AIX. This verb cannot be used to modify existing downstream LUs.

The supplied parameters to this verb include a base name for the new LUs and the range of NAU addresses. The new LU names are generated by combining the base name with the NAU addresses. For example, a base name of LUNME combined with a NAU range of 11 to 14 would define the LUs LUNME011, LUNME012, LUNME013 and LUNME014.

DEFINE\_DOWNSTREAM\_LU\_RANGE can also be used to define downstream LUs used by applications that communicate with a CS/AIX Primary RUI application. For more information about Primary RUI, see IBM Communications Server for Data Center Deployment on AIX or Linux LUA Programmer's Guide.

## VCB structure

```
typedef struct define_downstream_lu_range
{
    AP_UINT16      opcode;          /* verb operation code          */
    unsigned char  reserv2;        /* reserved                      */
    unsigned char  format;        /* reserved                      */
    AP_UINT16      primary_rc;     /* primary return code          */
    AP_UINT32      secondary_rc;   /* secondary return code        */
    unsigned char  dslu_base_name[5]; /* Downstream LU base name     */
    unsigned char  reserv3;        /* reserved                      */
    unsigned char  description[32]; /* resource description         */
    unsigned char  reserv1[16];    /* reserved                      */
    unsigned char  min_nau;        /* Minimum NAU address in range */
    unsigned char  max_nau;        /* Maximum NAU address in range */
    unsigned char  dspu_name[8];   /* Downstream PU name          */
    unsigned char  host_lu_name[8]; /* Host LU or Pool name        */
    unsigned char  allow_timeout;  /* Allow timeout of host LU?    */
    unsigned char  delayed_logon;  /* Allow delayed logon to host LU */
    unsigned char  reserv4[6];     /* reserved                      */
} DEFINE_DOWNSTREAM_LU_RANGE;
```

## Supplied parameters

The application supplies the following parameters:

### *opcode*

AP\_DEFINE\_DOWNSTREAM\_LU\_RANGE

## DEFINE\_DOWNSTREAM\_LU\_RANGE

### ***dslu\_base\_name***

Base name for the names of the new LUs. This is a 5-byte type-A EBCDIC string (starting with a letter), padded on the right with EBCDIC spaces if the base name is less than 5 characters. CS/AIX generates the LU name for each LU by appending the 3-digit decimal value of the NAU address to this name.

### ***description***

A null-terminated text string (0-31 characters followed by a null character) describing the downstream LUs (the same string is used for each LU in the range). This string is for information only; it is stored in the node's configuration file and returned on the QUERY\_DOWNSTREAM\_LU verb, but CS/AIX does not make any other use of it.

### ***min\_nau***

NAU address of the first LU, in the range 1-255.

### ***max\_nau***

NAU address of the last LU, in the range 1-255.

### ***dspu\_name***

Name of the downstream PU (as specified on the DEFINE\_LS verb) which the downstream LUs in this range will use. This is an 8-byte type-A EBCDIC string (starting with a letter), padded on the right with EBCDIC spaces if necessary.

### ***host\_lu\_name***

Name of host LU or host LU pool that the downstream LUs in the given range will be mapped to. This is an 8-byte type-A EBCDIC string, padded on the right with EBCDIC spaces if necessary.

If the downstream LUs are used to communicate with a CS/AIX Primary RUI application instead of a host, set this field to the string #PRIRUI# in EBCDIC.

### ***allow\_timeout***

Specifies whether to allow the sessions this range of downstream LUs have with the upstream LU to timeout if the session is left inactive for the timeout period specified on the upstream LU definition. Possible values are:

#### **AP\_YES**

Allow the sessions this range of downstream LUs have with the upstream LU to timeout.

#### **AP\_NO**

Do not allow the session this range of downstream LUs have with the upstream LU to timeout.

This field is ignored if the downstream LUs are used to communicate with a CS/AIX Primary RUI application instead of a host.

### ***delayed\_logon***

Specifies whether to use delayed logon with this range of downstream LUs (the upstream LU is not activated until the user requests it). Possible values are:

#### **AP\_YES**

Use delayed logon with this range of downstream LUs; the upstream LU is not activated until the user requests it.

#### **AP\_NO**

Do not use delayed logon with this range of downstream LUs.

This field is ignored if the downstream LUs are used to communicate with a CS/AIX Primary RUI application instead of a host.

## Returned parameters: successful execution

If the verb executes successfully, CS/AIX returns the following parameters:

### ***primary\_rc***

AP\_OK

## Returned parameters: parameter check

If the verb does not execute because of a parameter error, CS/AIX returns the following parameters:

**primary\_rc**

AP\_PARAMETER\_CHECK

**secondary\_rc**

Possible values are:

**AP\_INVALID\_DNST\_LU\_NAME**The supplied *dslu\_base\_name* parameter contained a character that was not valid.**AP\_INVALID\_NAU\_ADDRESS**

One or more of the supplied NAU addresses was not in the valid range.

**AP\_INVALID\_ALLOW\_TIMEOUT**The supplied *allow\_timeout* parameter value was not valid.**AP\_INVALID\_DELAYED\_LOGON**The supplied *delayed\_logon* parameter value was not valid.

Appendix B, “Common return codes,” on page 661 lists further secondary return codes associated with AP\_PARAMETER\_CHECK, which are common to all NOF verbs.

**Returned parameters: state check**

If the verb does not execute because of a state error, CS/AIX returns the following parameters.

**primary\_rc**

AP\_STATE\_CHECK

**secondary\_rc**

Possible values are:

**AP\_INVALID\_PU\_NAME**The specified *dspu\_name* parameter was not valid.**AP\_PU\_NOT\_DEFINED**The specified *dspu\_name* parameter did not match any defined PU name.**AP\_INVALID\_PU\_TYPE**The PU specified by the *dspu\_name* parameter is not a downstream PU that supports SNA gateway.**AP\_LU\_ALREADY\_DEFINED**

An LU has already been defined with a name that matches one of the names in the range. The existing LU cannot be modified using this verb.

**AP\_DSLU\_ACTIVE**

An LU with a name that matches one of the names in the range is already active. The existing LU cannot be modified using this verb.

**AP\_LU\_NAU\_ADDR\_ALREADY\_DEFD**

An LU has already been defined with an NAU address that matches one of the addresses in the range.

**AP\_INVALID\_HOST\_LU\_NAME**

The specified host LU name was not valid.

**AP\_LU\_NAME\_POOL\_NAME\_CLASH**

One of the LU names in the range clashes with the name of an existing LU pool.

Appendix B, “Common return codes,” on page 661 lists further secondary return codes associated with AP\_STATE\_CHECK, which are common to all NOF verbs.

**Returned parameters: function not supported**

If the verb does not execute successfully because the local node's configuration does not support it, CS/AIX returns the following parameters:

## DEFINE\_DSPU\_TEMPLATE

### *primary\_rc*

#### **AP\_FUNCTION\_NOT\_SUPPORTED**

The local node does not support SNA gateway; this is defined by the *pu\_conc\_support* parameter on the DEFINE\_NODE verb.

## Returned parameters: other conditions

Appendix B, “Common return codes,” on page 661 lists further combinations of primary and secondary return codes that are common to all NOF verbs.

## DEFINE\_DSPU\_TEMPLATE

The DEFINE\_DSPU\_TEMPLATE verb defines a template for downstream LUs that use the CS/AIX SNA gateway feature. This template is used to define downstream LUs on a group of downstream workstations when a workstation connects over an implicit link (a link not previously defined).

DEFINE\_DSPU\_TEMPLATE can also be used to define downstream LUs that support applications communicating with a Primary RUI application on the CS/AIX node. For more information about Primary RUI, see IBM Communications Server for Data Center Deployment on AIX or Linux LUA Programmer's Guide.

## VCB structure

```
typedef struct define_dspu_template
{
    AP_UINT16          opcode;           /* verb operation code      */
    unsigned char     reserv3;          /* reserved                  */
    unsigned char     format;           /* reserved                  */
    AP_UINT16         primary_rc;       /* primary return code      */
    AP_UINT32         secondary_rc;     /* secondary return code    */
    unsigned char     template_name[8]; /* Name of template        */
    unsigned char     description[32];  /* resource description     */
    unsigned char     reserv2[16];     /* reserved                  */
    unsigned char     modify_template; /* Modify existing template? */
    unsigned char     reserv1[11];     /* reserved                  */
    AP_UINT16         max_instance;     /* Max active template     */
    /* instances */
    AP_UINT16         num_of_dslu_templates; /* number of DSLU templates*/
} DEFINE_DSPU_TEMPLATE;

typedef struct dslu_template
{
    unsigned char     min_nau;          /* Minimum NAU address in range*/
    unsigned char     max_nau;          /* Maximum NAU address in range*/
    unsigned char     allow_timeout;    /* Allow timeout of host LU?   */
    unsigned char     delayed_logon;    /* Allow delayed logon to host */
    /* LU */
    unsigned char     reserv1[8];       /* reserved                  */
    unsigned char     host_lu[8];       /* Host LU or Pool name      */
} DSLU_TEMPLATE;
```

## Supplied parameters

The application supplies the following parameters:

### ***opcode***

AP\_DEFINE\_DSPU\_TEMPLATE

### ***template\_name***

The name of the template for downstream LUs that are present on a group of downstream workstations.

### ***description***

Resource description that is returned on the QUERY\_DSPU\_TEMPLATE verb.

***modify\_template***

Specifies whether this verb should add additional DSLU templates to an existing DSPU template or should replace an existing DSPU template. Possible values are:

**AP\_MODIFY\_DSPU\_TEMPLATE**

If the named DSPU template does not exist, then it is created. If the named DSPU template does exist, then appended DSLU templates are added to the existing DSPU template.

**AP\_REPLACE\_DSPU\_TEMPLATE**

A new template is created, overwriting any existing definition.

***max\_instance***

The maximum number of instances of the template that can be active concurrently. When the limit is reached, no new instances are created. Specify a value in the range 0-65,535, where 0 (zero) indicates no limit.

***num\_of\_dslu\_templates***

The number of downstream LU (DSLU) templates being defined by this verb.

The subrecord `dslu_template` contains the following parameters:

***min\_nau***

NAU address of the first downstream PU, in the range 1-255.

***max\_nau***

NAU address of the last downstream PU, in the range 1-255.

***allow\_timeout***

Specifies whether to timeout host LUs used by the downstream LU if the session is left inactive for the timeout period specified on the host LU definition. Possible values are:

**AP\_YES**

CS/AIX is allowed to timeout host LUs used by this downstream LU.

**AP\_NO**

CS/AIX is not allowed to timeout host LUs used by this downstream LU.

This field is ignored if the downstream LUs are used to communicate with a CS/AIX Primary RUI application instead of a host.

***delayed\_logon***

Specifies whether to delay connecting the downstream LU to the host LU until the first data is received from the downstream LU. Possible values are:

**AP\_YES**

CS/AIX delays connecting the downstream LU to the host LU. A simulated logon screen is sent to the downstream LU.

**AP\_NO**

CS/AIX does not delay connecting the downstream LU to the host LU.

This field is ignored if the downstream LUs are used to communicate with a CS/AIX Primary RUI application instead of a host.

***host\_lu***

Name of the host LU or host LU pool that the downstream LU uses. This name is an 8-byte type-A character string.

If the downstream LUs are used to communicate with a CS/AIX Primary RUI application instead of a host, set this field to the string `#PRIRUI#` in EBCDIC.

## Returned parameters: successful execution

If the verb executes successfully, CS/AIX returns the following parameters:

***primary\_rc***

AP\_OK

## Returned parameters: parameter check

If the verb does not execute because of a parameter error, CS/AIX returns the following parameters:

### *primary\_rc*

AP\_PARAMETER\_CHECK

### *secondary\_rc*

Possible values are:

#### **AP\_INVALID\_TEMPLATE\_NAME**

The name specified for the *template\_name* parameter was not valid.

#### **AP\_INVALID\_NAU\_ADDRESS**

The *min\_nau* or *max\_nau* parameter was not valid.

#### **AP\_INVALID\_NAU\_RANGE**

The address specified on the *min\_nau* or *max\_nau* parameters was not in the valid range.

#### **AP\_CLASHING\_NAU\_RANGE**

The range of addresses specified by the *min\_nau* parameter through the *max\_nau* parameter in a *dslu\_template* subrecord clashes with a range specified by another *dslu\_template* subrecord in the template named by the *template\_name* parameter.

#### **AP\_INVALID\_NUM\_DSPU\_TEMPLATES**

The value specified for the *num\_of\_dslu\_templates* parameter was not in the valid range.

#### **AP\_INVALID\_ALLOW\_TIMEOUT**

The value specified for the *allow\_timeout* parameter was not valid.

#### **AP\_INVALID\_DELAYED\_LOGON**

The value specified for the *delayed\_logon* parameter was not valid.

#### **AP\_INVALID\_MODIFY\_TEMPLATE**

The value specified for the *modify\_template* parameter was not valid.

Appendix B, "Common return codes," on page 661 lists further secondary return codes associated with AP\_PARAMETER\_CHECK, which are common to all NOF verbs.

## Returned parameters: state check

If the verb does not execute because of a state error, CS/AIX returns the following parameters.

### *primary\_rc*

AP\_STATE\_CHECK

### *secondary\_rc*

Possible values are:

#### **AP\_INVALID\_HOST\_LU\_NAME**

The specified *host\_lu\_name* parameter value was not valid.

Appendix B, "Common return codes," on page 661 lists further secondary return codes associated with AP\_STATE\_CHECK, which are common to all NOF verbs.

## Returned parameters: function not supported

If the verb does not execute successfully because the local node's configuration does not support it, CS/AIX returns the following parameters:

### *primary\_rc*

#### **AP\_FUNCTION\_NOT\_SUPPORTED**

The local node does not support SNA gateway; this is defined by the *pu\_conc\_support* parameter on the DEFINE\_NODE verb.

## Returned parameters: other conditions

Appendix B, “Common return codes,” on page 661, lists further combinations of primary and secondary return codes that are common to all NOF verbs.

## DEFINE\_FOCAL\_POINT

The DEFINE\_FOCAL\_POINT verb specifies the focal point for a particular Management Services category. When a new focal point is specified, CS/AIX attempts to establish an implicit primary focal point relationship with the specified focal point by sending an MS\_CAPABILITIES request.

## VCB structure

```
typedef struct define_focal_point
{
    AP_UINT16      opcode;                /* verb operation code          */
    unsigned char  reserv2;              /* reserved                     */
    unsigned char  format;               /* reserved                     */
    AP_UINT16      primary_rc;          /* primary return code         */
    AP_UINT32      secondary_rc;       /* secondary return code       */
    unsigned char  reserved;           /* reserved                     */
    unsigned char  ms_category[8];     /* management services category */
    unsigned char  fp_fqcp_name[17];   /* Fully qualified focal point cp name */
    unsigned char  ms_appl_name[8];    /* Focal point application name */
    unsigned char  description[32];    /* resource description         */
    unsigned char  reserv1[16];       /* reserved                     */
    unsigned char  backup;            /* is focal point a backup     */
    unsigned char  reserv3[16];       /* reserved                     */
} DEFINE_FOCAL_POINT;
```

## Supplied parameters

The application supplies the following parameters:

### ***opcode***

AP\_DEFINE\_FOCAL\_POINT

### ***ms\_category***

Management Services category. This may be either one of the category names specified in the MS Discipline-Specific Application Programs table of *Systems Network Architecture: Management Services Reference* (see the Bibliography), padded with EBCDIC spaces (0x40), or a user-defined category. A user-defined category name is an 8-byte type-1134 EBCDIC string, padded with EBCDIC spaces (0x40) if necessary.

### ***fp\_fqcp\_name***

Fully qualified control point name of the focal point. The name is a 17-byte EBCDIC string, right-padded with EBCDIC spaces. It consists of a network ID of up to 8 A-string characters, an EBCDIC dot (period) character, and a network name of up to 8 A-string characters.

### ***ms\_appl\_name***

Focal point application name. This is normally an EBCDIC string, using type-1134 characters; alternatively, it can be one of the MS Discipline-Specific Application Programs specified in *Systems Network Architecture: Management Services Reference* (see the Bibliography). The string must be 8 characters long; pad on the right with EBCDIC space characters (0x40) if necessary.

### ***description***

A null-terminated text string (0-31 characters followed by a null character) describing the focal point. This string is for information only; it is stored in the node's configuration file and returned on the QUERY\_FOCAL\_POINT verb, but CS/AIX does not make any other use of it.

### ***backup***

Indicates whether the specified application is the main focal point for this category, or a backup focal point. Possible values are:

## DEFINE\_FOCAL\_POINT

### AP\_YES

Backup focal point (used only if the main focal point is not available).

### AP\_NO

Main focal point.

## Returned parameters: successful execution

If the verb executes successfully, CS/AIX returns the following parameters:

### *primary\_rc*

#### AP\_OK

The focal point was defined as requested.

## Returned parameters: parameter check

If the verb does not execute because of a parameter error, CS/AIX returns the following parameters:

### *primary\_rc*

AP\_PARAMETER\_CHECK

### *secondary\_rc*

Possible values are:

#### AP\_INVALID\_CATEGORY\_NAME

The supplied category name contained a character that was not valid.

#### AP\_INVALID\_FP\_NAME

The fully qualified name or the application name was not valid.

Appendix B, "Common return codes," on page 661 lists further secondary return codes associated with AP\_PARAMETER\_CHECK, which are common to all NOF verbs.

## Returned parameters: function not supported

If the verb does not execute successfully because the local node configuration does not support it, CS/AIX returns the following parameters:

### *primary\_rc*

#### AP\_FUNCTION\_NOT\_SUPPORTED

The local node does not support MS network management functions; this is defined by the *mds\_supported* parameter on the DEFINE\_NODE verb.

## Returned parameters: replaced

If the verb does not execute successfully because it is followed by another verb specifying a different focal point, CS/AIX returns the following parameters.

### *primary\_rc*

#### AP\_REPLACED

Another DEFINE\_FOCAL\_POINT was issued to the same node while this verb was outstanding, specifying a different focal point for the same MS category. This verb was abandoned; the node will attempt to contact the focal point specified by the second verb.

## Returned parameters: unsuccessful

If the verb does not execute successfully because the focal point relationship cannot be established, CS/AIX returns the following parameters:

### *primary\_rc*

AP\_UNSUCCESSFUL



**secondary\_rc**

Possible values are:

**AP\_IMPLICIT\_REQUEST\_REJECTED**

The specified focal point rejected the request.

**AP\_IMPLICIT\_REQUEST\_FAILED**

The node could not send the request to the specified focal point; this may be because the specified control point or application was not found.

**Returned parameters: other conditions**

Appendix B, “Common return codes,” on page 661 lists further combinations of primary and secondary return codes that are common to all NOF verbs.

**DEFINE\_INTERNAL\_PU**

The DEFINE\_INTERNAL\_PU verb defines a PU on the local node that is served by DLUR. (To define a downstream PU served by DLUR or SNA gateway, or to define a local PU that is directly attached to the host, use DEFINE\_LS instead of DEFINE\_INTERNAL\_PU.)

**VCB structure**

```
typedef struct define_internal_pu
{
    AP_UINT16          opcode;           /* verb operation code */
    unsigned char     reserv2;          /* reserved */
    unsigned char     format;           /* reserved */
    AP_UINT16         primary_rc;       /* primary return code */
    AP_UINT32         secondary_rc;     /* secondary return code */
    unsigned char     pu_name[8];      /* internal PU name */
    INTERNAL_PU_DEF_DATA def_data;     /* defined data */
} DEFINE_INTERNAL_PU;
```

```
typedef struct internal_pu_def_data
{
    unsigned char     description[32];  /* resource description */
    unsigned char     initially_active; /* is PU initially active? */
    unsigned char     reserv1[15];     /* reserved */
    unsigned char     dlus_name[17];   /* DLUS name */
    unsigned char     bkup_dlus_name[17]; /* backup DLUS name */
    unsigned char     pu_id[4];        /* PU identifier */
    AP_UINT16         dlus_retry_timeout; /* DLUS retry timeout */
    AP_UINT16         dlus_retry_limit; /* DLUS retry limit */
    unsigned char     conventional_lu_compression; /* compression for LU 0-3? */
    unsigned char     conventional_lu_cryptography; /* reserved */
    unsigned char     pu_can_send_dddlu_offline; /* does the PU send NMVT */
    unsigned char     /* (power off) to host? */
    unsigned char     reserv2[1];      /* reserved */
} INTERNAL_PU_DEF_DATA;
```

**Supplied parameters**

The application supplies the following parameters:

**opcode**

AP\_DEFINE\_INTERNAL\_PU

**pu\_name**

Name of the internal PU that is being defined. This is a type-A EBCDIC string (starting with a letter), padded on the right with EBCDIC spaces.

This name should match the PU name configured on the host. (CS/AIX sends both the PU name and PU ID to the host to identify the PU. The host normally identifies the PU by its PU name, or by the PU ID if it cannot find a matching PU name.)

***def\_data.description***

A null-terminated text string (0-31 characters followed by a null character) describing the internal PU. This string is for information only; it is stored in the node's configuration file and returned on the QUERY\_DLUR\_PU and QUERY\_PU verbs, but CS/AIX does not make any other use of it.

***def\_data.initially\_active***

Specifies whether this internal PU is automatically started when the node is started. Possible values are:

**AP\_YES**

The PU is automatically started when the node is started.

**AP\_NO**

The PU is not automatically started; it must be started manually.

***def\_data.dlus\_name***

Name of DLUS node which DLUR will use when it initiates SSCP-PU activation. The name is a 17-byte EBCDIC string, right-padded with EBCDIC spaces. It consists of a network ID of up to 8 A-string characters, an EBCDIC dot (period) character, and a network name of up to 8 A-string characters.

To indicate that DLUR should use the global default DLUS, set this parameter to 17 binary zeros. In this case, you must also use DEFINE\_DLUR\_DEFAULTS to define the global default DLUS.

***def\_data.bkup\_dlus\_name***

Name of DLUS node which will serve as the backup DLUS for this PU. The name is a 17-byte EBCDIC string, right-padded with EBCDIC spaces. It consists of a network ID of up to 8 A-string characters, an EBCDIC dot (period) character, and a network name of up to 8 A-string characters.

To indicate that DLUR should use the global backup default DLUS, set this parameter to 17 binary zeros. In this case, you must also use DEFINE\_DLUR\_DEFAULTS to define the global backup default DLUS.

***def\_data.pu\_id***

PU identifier. This is a 4-byte hexadecimal string, consisting of a block number (3 hexadecimal digits) and a node number (5 hexadecimal digits). The PU ID should match the *pu\_id* configured at the host. (CS/AIX sends both the PU name and PU ID to the host to identify the PU. The host normally identifies the PU by its PU name, or by the PU ID if it cannot find a matching PU name.)

***def\_data.dlus\_retry\_timeout***

Reactivation timer for contacting a DLUS. If CS/AIX fails to contact the DLUS, this parameter specifies the time in seconds between retries. The interval between the first and second attempts is always 1 second.

Specify a value in the range 0x0001-0xFFFF. If zero is specified, then the defaults specified using the DEFINE\_DLUR\_DEFAULTS verb are used.

***def\_data.dlus\_retry\_limit***

Retry count for contacting a DLUS. This parameter is used to specify the number of times CS/AIX should retry if it fails to contact the DLUS on the first attempt.

Specify a value in the range 0x0001-0xFFFFE, or specify 0xFFFF to indicate that CS/AIX should retry indefinitely until it contacts the DLUS.

***def\_data.conventional\_lu\_compression***

Specifies whether data compression is requested for LU 0-3 sessions using this PU.

Possible values are:

**AP\_YES**

Data compression should be used for LU 0-3 sessions using this PU if the host requests it.

**AP\_NO**

Data compression should not be used for LU 0-3 sessions using this PU.

***def\_data.pu\_can\_send\_dddlu\_offline***

Specifies whether the local PU should send NMVT (power off) messages to the host. If the host system supports DDDL (Dynamic Definition of Dependent LUs), CS/AIX sends NMVT (power off) to

the host when it has finished using a dynamically defined LU. This allows the host to save resources by removing the definition when it is no longer required.

Possible values are:

**AP\_YES**

The local PU sends NMVT (power off) messages to the host.

**AP\_NO**

The local PU does not send NMVT (power off) messages to the host.

If the host supports DDDL but does not support the NMVT (power off) message, this parameter must be set to AP\_NO.

## Returned parameters: successful execution

If the verb executes successfully, CS/AIX returns the following parameters:

***primary\_rc***

AP\_OK

## Returned parameters: parameter check

If the verb does not execute because of a parameter error, CS/AIX returns the following parameters:

***primary\_rc***

AP\_PARAMETER\_CHECK

***secondary\_rc***

Possible values are:

**AP\_INVALID\_PU\_NAME**

The *pu\_name* parameter contained a character that was not valid.

**AP\_INVALID\_PU\_ID**

The *pu\_id* parameter contained a character that was not valid.

**AP\_INVALID\_DLUS\_NAME**

The *dlus\_name* parameter contained a character that was not valid or was not in the correct format.

**AP\_INVALID\_BKUP\_DLUS\_NAME**

The *bkup\_dlus\_name* parameter contained a character that was not valid or was not in the correct format.

## Returned parameters: state check

If the verb does not execute because of a state error, CS/AIX returns the following parameters.

***primary\_rc***

AP\_STATE\_CHECK

***secondary\_rc***

**AP\_PU\_ALREADY\_DEFINED**

A PU with the specified name has already been defined.

## Returned parameters: function not supported

If the verb does not execute because the node's configuration does not support it, CS/AIX returns the following parameter:

***primary\_rc***

**AP\_FUNCTION\_NOT\_SUPPORTED**

The node does not support DLUR; this is defined by the *dlur\_support* parameter on the DEFINE\_NODE verb.

## Returned parameters: other conditions

Appendix B, “Common return codes,” on page 661 lists further combinations of primary and secondary return codes that are common to all NOF verbs.

## DEFINE\_LOCAL\_LU

The DEFINE\_LOCAL\_LU verb defines a new local LU. It can also be used to modify the attach routing data, *disable* parameter, or description of an existing LU (or of the default LU associated with the local node's Control Point), but not any of the other parameters; when modifying an existing LU, all the other parameters must be set to their currently defined values.

## VCB structure

```
typedef struct define_local_lu
{
    AP_UINT16          opcode;          /* verb operation code          */
    unsigned char      reserv2;         /* reserved                     */
    unsigned char      format;         /* reserved                     */
    AP_UINT16          primary_rc;      /* primary return code          */
    AP_UINT32          secondary_rc;    /* secondary return code        */
    unsigned char      lu_name[8];     /* local LU name                */
    LOCAL_LU_DEF_DATA def_data;        /* defined data                  */
} DEFINE_LOCAL_LU;
```

```
typedef struct local_lu_def_data
{
    unsigned char      description[32]; /* resource description          */
    unsigned char      reserv1;        /* reserved                     */
    unsigned char      security_list_name[14]; /* security access list name */
    unsigned char      reserv3;        /* reserved                     */
    unsigned char      lu_alias[8];    /* local LU alias               */
    unsigned char      nau_address;    /* NAU address                  */
    unsigned char      syncpt_support; /* is Syncpoint supported?     */
    AP_UINT16          lu_session_limit; /* LU session limit            */
    unsigned char      default_pool;   /* is LU in the pool of default */
    /* LUs?                          */
    unsigned char      reserv2;        /* reserved                     */
    unsigned char      pu_name[8];     /* PU name                      */
    unsigned char      lu_attributes; /* LU attributes                */
    unsigned char      sscp_id[6];     /* SSCP ID                      */
    unsigned char      disable;        /* disable or enable local LU  */
    ROUTING_DATA       attach_routing_data; /* routing data for incoming */
    /* attaches                        */
    unsigned char      reserv6;        /* reserved                     */
    unsigned char      reserv4[7];     /* reserved                     */
    unsigned char      reserv5[16];    /* reserved                     */
} LOCAL_LU_DEF_DATA;
```

```
typedef struct routing_data
{
    unsigned char      sys_name[128]; /* Name of target system for TP */
    AP_INT32           timeout;      /* timeout value in seconds     */
    unsigned char      back_level;   /* reserved                     */
    unsigned char      reserved[59]; /* reserved                     */
} ROUTING_DATA;
```

## Supplied parameters

The application supplies the following parameters:

### ***opcode***

AP\_DEFINE\_LOCAL\_LU

### ***lu\_name***

Name of the local LU. This is an 8-byte type-A EBCDIC string (starting with a letter), padded on the right with EBCDIC spaces. It must not match any other local LU name, or the fully-qualified partner LU name of any partner LU.

To modify the attach routing data or description of the default LU associated with the local node's Control Point, set this parameter to 8 binary zeros.

***def\_data.description***

A null-terminated text string (0-31 characters followed by a null character) describing the local LU. This string is for information only; it is stored in the node's configuration file and returned on the QUERY\_LOCAL\_LU verb, but CS/AIX does not make any other use of it.

***def\_data.security\_list\_name***

Name of the security access list used by this local LU (defined using the DEFINE\_SECURITY\_ACCESS\_LIST verb). This parameter restricts the LU so that only the users named in the specified list can use it. To specify that the LU is available for use by any user, set this parameter to 14 binary zeros.

***def\_data.lu\_alias***

Alias of the local LU. This is an 8-byte ASCII string, using any locally displayable characters, padded on the right to 8 bytes if necessary.

***def\_data.nau\_address***

Network accessible unit address of the LU. Specify zero if the LU is an independent LU, or an address in the range 1-255 if the LU is a dependent LU.

***def\_data.syncpt\_support***

Specifies whether the LU supports Syncpoint functions. Set this to AP\_YES only if you have a Sync Point Manager (SPM) and Conversation Protected Resource Manager (C-PRM) in addition to the standard CS/AIX product. Possible values are:

**AP\_YES**

Syncpoint is supported.

**AP\_NO**

Syncpoint is not supported.

***def\_data.lu\_session\_limit***

The maximum total number of sessions (across all modes) supported by the LU.

For a dependent LU, this must be set to 1. For an independent LU, specify zero for no limit, or a value in the range 1-65,535. If you specify an explicit limit, note the following:

- If the LU will be communicating with parallel-session remote LUs, the session limit must include sufficient sessions for CNOS negotiation; a safe minimum is 3, or an additional 2 sessions for each partner LU.
- The LU session limit must be greater than or equal to the sum of the session limits for all modes that the LU will use.

***def\_data.default\_pool***

Specifies whether the LU is in the pool of default dependent LUs. For more information, see [“Default LUs”](#) on page 99. Possible values are:

**AP\_YES**

The LU is in the pool of default LUs, and can be used by applications that do not specify an LU name.

**AP\_NO**

The LU is not in the pool.

If the LU is an independent LU, this parameter is reserved.

***def\_data.pu\_name***

Name of the PU which this LU will use, as specified on the DEFINE\_LS verb. This field is used only by dependent LUs, and should be set to 8 binary zeros for independent LUs. The name is an 8-byte type-A EBCDIC string (starting with a letter), padded on the right with EBCDIC spaces if necessary.

***def\_data.lu\_attributes***

Identifies additional information about the LU. Possible values are:

## DEFINE\_LOCAL\_LU

### **AP\_NONE**

No additional information identified.

### **AP\_DISABLE\_PWSUB**

Disable password substitution support for the local LU. Password substitution means that passwords are encrypted before transmission between the local and remote LUs, rather than being sent as clear text. CS/AIX normally uses password substitution if the remote system supports it.

This value is provided as a work-around for communications with some remote systems that do not implement password substitution correctly. If you use this option, you should be aware that this involves sending and receiving passwords in clear text (which may represent a security risk). Do not set it unless there are problems with the remote system's implementation of password substitution.

### ***def\_data.sscp\_id***

Specifies the ID of the SSCP permitted to activate this LU. This ID is a 6-byte binary string. This parameter is used only by dependent LUs, and is set to all binary zeros if the LU is an independent LU or if the LU can be activated by any SSCP.

### ***def\_data.disable***

Specifies whether the local LU should be disabled or enabled. This field is only used for dependent LU6.2 LUs, it is reserved otherwise. Possible values are:

#### **AP\_YES**

Disable the local LU.

#### **AP\_NO**

Enable the local LU.

### ***def\_data.attach\_routing\_data.sys\_name***

The system name of the target computer for incoming Allocate requests (requests from a partner TP to start an APPC or CPI-C conversation) that arrive at this local LU.

If the target TP is a broadcast queued TP (that is, servers are informed of its location when it starts, so that they can route incoming Allocate requests to it), or if it always runs on the same CS/AIX server as the node that owns this LU, set this parameter to binary zeros. Otherwise, set it to the name of the computer where the TP runs.

The name must be either an alias or a fully-qualified name; you cannot specify an IP address. If the system name includes a . (period) character, CS/AIX assumes that it is a fully-qualified name; otherwise it performs a DNS lookup to determine the system name.

### ***def\_data.attach\_routing\_data.timeout***

The timeout value for dynamic load requests. A request will time out if the invoked TP has not issued a Receive\_Allocate verb (APPC), or Accept\_Conversation or Accept\_Incoming (CPI-C), within this time. Specify the timeout value in seconds, or -1 to indicate no timeout (dynamic load requests will wait indefinitely).

## **Returned parameters: successful execution**

If the verb executes successfully, CS/AIX returns the following parameters:

### ***primary\_rc***

AP\_OK

## **Returned parameters: parameter check**

If the verb does not execute because of a parameter error, CS/AIX returns the following parameters:

### ***primary\_rc***

AP\_PARAMETER\_CHECK

### ***secondary\_rc***

Possible values are:

**AP\_INVALID\_DISABLE**

The *disable* parameter was not set to a valid value.

**AP\_INVALID\_LU\_NAME**

The supplied LU name contained a character that was not valid.

**AP\_INVALID\_NAU\_ADDRESS**

The supplied NAU address was not in the valid range.

**AP\_INVALID\_SESSION\_LIMIT**

The supplied session limit was not in the valid range.

**AP\_INVALID\_TIMEOUT**

The supplied timeout value was not in the valid range.

Appendix B, “Common return codes,” on page 661 lists further secondary return codes associated with AP\_PARAMETER\_CHECK, which are common to all NOF verbs.

## Returned parameters: state check

If the verb does not execute because of a state error, CS/AIX returns the following parameters.

***primary\_rc***

AP\_STATE\_CHECK

***secondary\_rc***

Possible values are:

**AP\_INVALID\_LU\_NAME**

Either the *lu\_name* or *lu\_alias* parameter contained a character that was not valid, or the LU name matched the fully-qualified name of a partner LU.

**AP\_LU\_ALREADY\_DEFINED**

An LU with this name has already been defined. You cannot use this verb to modify any parameters of an existing LU except the attach routing data.

**AP\_PU\_NOT\_DEFINED**

The *pu\_name* parameter did not match any defined PU name.

**AP\_SECURITY\_LIST\_NOT\_DEFINED**

The *security\_list\_name* parameter did not match any defined security access list name.

**AP\_LU\_ALIAS\_ALREADY\_USED**

An LU with this alias has already been defined. You cannot use this verb to modify any parameters of an existing LU except the attach routing data.

Appendix B, “Common return codes,” on page 661 lists further secondary return codes associated with AP\_STATE\_CHECK, which are common to all NOF verbs.

## Returned parameters: other conditions

Appendix B, “Common return codes,” on page 661 lists further combinations of primary and secondary return codes that are common to all NOF verbs.

## Default LUs

You can set up the configuration of local LUs so that applications do not have to specify an LU name explicitly when starting a conversation; the node will select a suitable default LU for the application to use. The method for doing this depends on whether the applications require dependent or independent LUs, as follows. You cannot provide this facility for both dependent and independent LUs.

- If the applications require dependent LUs, use the *default\_pool* parameter on DEFINE\_LOCAL\_LU for one or more dependent LUs, to specify that they can be used as default LUs. When an application attempts to start a conversation without specifying a local LU name, CS/AIX will select an unused LU from the pool of LUs defined as default LUs.

## DEFINE\_LS

- You can define LUs on more than one node as default LUs. An application requesting a default LU may be assigned to any of these LUs as available; there is no requirement for the LU to be on the same computer as the application. However, if you are defining partner LUs for the applications, these must be defined on all nodes where default LUs are defined (so that the application can contact the correct partner LU using any of the default local LUs).
- If the applications require independent LUs, do not use the *default\_pool* parameter to define any local LUs as default LUs. In this case, an application requesting a default LU will be assigned to the LU associated with a local node's CP (this is an independent LU automatically defined by CS/AIX for each node).

## DEFINE\_LS

DEFINE\_LS is used to define a new link station (LS) or modify an existing one. Before issuing this verb, you must issue the DEFINE\_PORT verb to define the port that this LS uses. Link specific data is concatenated to the basic structure.

You cannot use DEFINE\_LS to modify the port used by an existing LS; the *port\_name* specified on the verb must match the previous definition of the LS. The LS can be modified only if it is not started.

## VCB structure

```
typedef struct define_ls
{
    AP_UINT16      opcode;          /* verb operation code          */
    unsigned char  reserv2;        /* reserved                      */
    unsigned char  format;        /* reserved                      */
    AP_UINT16      primary_rc;     /* primary return code          */
    AP_UINT32      secondary_rc;  /* secondary return code        */
    unsigned char  ls_name[8];    /* name of link station         */
    LS_DEF_DATA    def_data;      /* LS defined data              */
} DEFINE_LS;
```

```
typedef struct ls_def_data
{
    unsigned char  description[32]; /* resource description          */
    unsigned char  initially_active; /* is this LS initially active? */
    unsigned char  reserv2;        /* reserved                      */
    AP_UINT16      react_timer;    /* timer for retrying failed LS */
    AP_UINT16      react_timer_retry; /* retry count for failed LS */
    AP_UINT16      activation_count; /* reserved                      */
    unsigned char  restart_on_normal_deact; /* restart the link on any
                                        /* failure                      */
    unsigned char  reserv3[7];     /* reserved                      */
    unsigned char  port_name[8];   /* name of associated port       */
    unsigned char  adj_cp_name[17]; /* adjacent CP name             */
    unsigned char  adj_cp_type;    /* adjacent node type           */
    LINK_ADDRESS   dest_address;   /* destination address          */
    unsigned char  auto_act_supp;  /* auto-activate supported      */
    unsigned char  tg_number;      /* pre-assigned TG number       */
    unsigned char  limited_resource; /* limited resource            */
    unsigned char  solicit_sscp_sessions; /* solicit SSCP sessions */
    unsigned char  pu_name[8];    /* Local PU name (reserved if
                                        /* solicit_sscp_sessions is set
                                        /* to AP_NO)                   */
    unsigned char  disable_remote_act; /* disable remote activation */
    unsigned char  dspu_services;  /* Services provided for
                                        /* downstream PU               */
    unsigned char  dspu_name[8];   /* Downstream PU name (reserved
                                        /* if dspu_services is AP_NONE) */
    unsigned char  dlus_name[17];  /* DLUS name if dspu_services */
    unsigned char  /* set to AP_DLUR */
    unsigned char  bkup_dlus_name[17]; /* Backup DLUS name if
                                        /* dspu_services set to AP_DLUR */
    unsigned char  hpr_supported;  /* does the link support HPR? */
    unsigned char  hpr_link_lvl_error; /* does the link use link-level
                                        /* error recovery for HPR frms? */
    AP_UINT16      link_deact_timer; /* link deactivation timer */
    unsigned char  reserv1;        /* reserved                      */
    unsigned char  default_nn_server; /* default LS to NN server? */
    unsigned char  ls_attributes[4]; /* LS attributes                */
    unsigned char  adj_node_id[4]; /* adjacent node ID             */
}
```



```

unsigned char    local_node_id[4];        /* local node ID                */
unsigned char    cp_cp_sess_support;     /* CP-CP session support        */
unsigned char    use_default_tg_chars;   /* Use the default tg_chars     */
TG_DEFINED_CHARS tg_chars;               /* TG characteristics          */
AP_UINT16       target_pacing_count;     /* target pacing count          */
AP_UINT16       max_send_btu_size;      /* maximum send BTU size        */
unsigned char    ls_role;                /* link station role            */
unsigned char    max_ifrm_rcvd;          /* no. before acknowledgement   */
AP_UINT16       dlus_retry_timeout;     /* seconds to recontact a DLUS  */
AP_UINT16       dlus_retry_limit;       /* attempts to recontact a DLUS */
unsigned char    conventional_lu_compression; /* compression for LU 0-3?    */
unsigned char    conventional_lu_cryptography; /* reserved                    */
unsigned char    reserv3a;               /* reserved                      */
unsigned char    retry_flags;            /* reserved                      */
AP_UINT16       max_activation_attempts; /* reserved                      */
AP_UINT16       activation_delay_timer;  /* reserved                      */
unsigned char    branch_link_type;       /* is link an up or down link   */
unsigned char    adj_brnn_cp_support;    /* adj CP allowed to be BrNN?   */
unsigned char    mltg_pacing_algorithm;  /* reserved                      */
unsigned char    reserv5;                /* reserved                      */
AP_UINT16       max_rcv_btu_size;        /* reserved                      */
unsigned char    tg_sharing_prohibited;  /* reserved                      */
unsigned char    link_spec_data_format;  /* reserved                      */
unsigned char    pu_can_send_dddllu_offline; /* does the PU send NMVT      */
/* (power off) to host?              */
unsigned char    reserv4[13];            /* reserved                      */
AP_UINT16       link_spec_data_len;      /* length of link specific data */
} LS_DEF_DATA;

```

```

typedef struct tg_defined_chars
{
    unsigned char    effect_cap;           /* effective capacity            */
    unsigned char    reserve1[5];         /* reserved                      */
    unsigned char    connect_cost;        /* connection cost              */
    unsigned char    byte_cost;           /* byte cost                    */
    unsigned char    reserve2;           /* reserved                      */
    unsigned char    security;            /* security                      */
    unsigned char    prop_delay;          /* propagation delay            */
    unsigned char    modem_class;         /* reserved                      */
    unsigned char    user_def_parm_1;     /* user-defined parameter 1     */
    unsigned char    user_def_parm_2;     /* user-defined parameter 2     */
    unsigned char    user_def_parm_3;     /* user-defined parameter 3     */
} TG_DEFINED_CHARS;

```

```

typedef struct link_address
{
    unsigned char    format;               /* type of link address         */
    unsigned char    reserve1;            /* reserved                      */
    AP_UINT16       length;                /* length                       */
    unsigned char    address[135];        /* address                      */
} LINK_ADDRESS;

```

DLC-specific data for SDLC:

```

typedef struct sdl_link_spec_data
{
    V0_MUX_INFO    mux_info;              /* Streams config info          */
    AP_UINT16       reserve8;             /* reserved                      */
    AP_UINT16       reserve9;             /* reserved                      */
    AP_UINT32       contact_timer;        /* contact timer (fast poll,    */
/* in ms)                */
    AP_UINT16       contact_timer_retry;  /* contact timer retry          */
    AP_UINT16       reserve1;            /* reserved                      */
    AP_UINT32       contact_timer2;      /* contact timer (slow poll,    */
/* in ms)                */
    AP_UINT16       contact_timer_retry2; /* contact timer 2 retry        */
    AP_UINT16       reserve2;            /* reserved                      */
    AP_UINT32       disc_timer;           /* disconnect timer (in ms)     */
    AP_UINT16       disc_timer_retry;    /* disconnect timer retry       */
    AP_UINT16       reserve3;            /* reserved                      */
    AP_UINT32       nve_poll_timer;       /* negative poll timer(fast poll) */
    AP_UINT16       nve_poll_timer_retry; /* negative poll timer retry    */
    AP_UINT16       reserve4;            /* reserved                      */
    AP_UINT32       nve_poll_timer2;     /* negative poll timer(slow poll) */
    AP_UINT16       nve_poll_timer_retry2; /* negative poll timer 2 retry  */
    AP_UINT16       reserve5;            /* reserved                      */
    AP_UINT32       no_resp_timer;        /* No response timer (T1 timer) */
/* (in ms)                */
}

```

## DEFINE\_LS

```

AP_UINT16    no_resp_timer_retry;    /* No response timer retry    */
AP_UINT16    reserve6;               /* reserved                    */
AP_UINT32    rem_busy_timer;        /* Remote busy timer (in ms)  */
AP_UINT16    rem_busy_timer_retry;  /* Remote busy timer retry    */
unsigned char re_tx_threshold;       /* I-frame retransmission threshold */
unsigned char repoll_threshold;      /* Poll retransmission threshold */
AP_UINT32    rr_timer;              /* RR turnaround timer (in ms) */
unsigned char group_address;         /* reserved                    */
unsigned char poll_frame;           /* Poll frame to use when Primary
                                     and contact polling secondary
                                     XID, DISC, SNRM, SNRME, TEST */
AP_UINT16    poll_on_iframe;        /* Can LS send poll bit on    */
AP_UINT16    stub_spec_data_len;    /* length of stub specific data */
STUB_SPEC_DATA stub_spec_data;      /* stub specific data          */
} SDL_LINK_SPEC_DATA;
typedef struct stub_spec_data
{
AP_INT32     mux_id;                /* reserved                    */
unsigned char opt1;                 /* options flag 1              */
unsigned char opt2;                 /* options flag 2              */
unsigned char pad[2];               /* reserved                    */
AP_UINT32    linesp;               /* line speed in bps           */
AP_UINT16    rcv_pool_size;        /* initial number of buffers for
                                     rcv pool                    */
AP_UINT16    poll_wait;            /* seconds between polling HMOD
                                     for errors                  */
AP_UINT16    hmod_data_len;        /* length of dial data string  */
unsigned char hmod_data[80];        /* dial data string            */
char          x21_sequence[255];    /* X21 selection sequence      */
unsigned char x21_retry_count;      /* X21 max call retries        */
AP_UINT16    x21_retry_delay;      /* X21 delay between retries   */
AP_UINT16    v25_tx_delay;         /* V25 pause before dialing   */
unsigned char cds1;                /* Wait for RI before DTR      */
unsigned char hex_hmod_data;        /* reserved                    */
unsigned char reserve1[2];          /* reserved                    */
} STUB_SPEC_DATA;

```

### DLC-specific data for QLLC:

```

typedef struct vql_ls_spec_data
{
V0_MUX_INFO  mux_info;              /* streams config info        */
AP_UINT16    reserve1;              /* reserved                    */
AP_UINT16    reserve2;              /* reserved                    */
unsigned char vc_type;              /* Virtual Circuit type        */
unsigned char req_rev_charge;       /* request reverse charge if
                                     non-zero                    */
unsigned char loc_packet;           /* loc->rem packet            */
unsigned char rem_packet;           /* rem->loc packet            */
unsigned char loc_wsize;            /* loc->rem window size       */
unsigned char rem_wsize;            /* rem->loc window size       */
AP_UINT16    fac_len;              /* reserved                    */
unsigned char fac[128];             /* reserved                    */
AP_UINT16    retry_limit;          /* times to retry send QXID,QSM,
                                     QDISC                       */
AP_UINT16    retry_timeout;        /* timeout for each of above tries */
AP_UINT16    idle_timeout;         /* timeout for no Q msgs during
                                     init                         */
AP_UINT16    pvc_id;               /* PVC logical channel identifier */
AP_UINT16    sn_id_len;            /* reserved                    */
unsigned char sn_id[4];            /* reserved                    */
AP_UINT16    cud_len;              /* length of any call user data
                                     to send                    */
unsigned char cud[128];            /* actual call user data       */
AP_UINT32    xtras;                /* reserved                    */
AP_UINT32    xtra_len;             /* reserved                    */
unsigned char rx_thruput_class;     /* Max Rx speed of calling DTE */
unsigned char tx_thruput_class;     /* Max Tx speed of calling DTE */
                                     /* Values for these fields are:
                                     0 - Default
                                     0x07 - 1200
                                     0x08 - 2400
                                     0x09 - 4800
                                     0x0a - 9600
                                     0x0b - 19200
                                     0x0b - 48000 */
unsigned char cugo;                /* Closed User Group (outgoing) */
}

```

```

    unsigned char  cug;                /* LS used by Closed User Group */
    AP_UINT16      cug_index;          /* Index of CUG using this LS */
    AP_UINT16      nuid_length;        /* Length of Network User ID */
    unsigned char  nuid_data[109];     /* Network User ID */
    unsigned char  reserve3[2];        /* Reserved field */
    unsigned char  rpoa_count;         /* Count of RPOA codes */
    AP_UINT16      rpoa_ids[30];       /* Array of RPOA codes */
} VQL_LS_SPEC_DATA;

```

DLC-specific data for Token Ring, Ethernet:

```

typedef struct gdlc_ls_cfg
{
    V0_MUX_INFO    mux_info;           /* Streams config info */
    AP_UINT16      reserve1;           /* reserved */
    AP_UINT16      reserve2;           /* reserved */
    AP_UINT16      xid_timeout;        /* XID timeout value */
    AP_UINT16      xid_retry_limit;    /* XID retransmission limit */
    AP_UINT16      t1_timeout;        /* T1 timeout value */
    AP_UINT16      t1_retry_limit;    /* I-frame retransmission limit */
    AP_UINT16      ack_time;           /* Acknowledgment timeout value */
    AP_UINT16      inact_time;         /* Inactivity timeout value */
    AP_UINT16      force_time;         /* Force halt time-out value */
    union
    {
        struct
        {
            AP_UINT16      pkt_prty;   /* reserved */
            AP_UINT16      dyna_wnd;   /* Dynamic window increment for
                                         transmit window */
        } tr;
    } uu;
    unsigned char  remote_name;        /* unique name of remote SAP */
} GDLC_LS_CFG;

typedef struct llc_link_spec_data
{
    V0_MUX_INFO    mux_info;           /* Streams config info */
    AP_UINT16      reserve1;           /* reserved */
    AP_UINT16      reserve2;           /* reserved */
    AP_UINT16      length;             /* reserved */
    AP_UINT16      xid_timer;          /* XID timeout value in seconds */
    AP_UINT16      xid_timer_retry;    /* XID retry limit */
    AP_UINT16      test_timer;         /* TEST timeout value in seconds */
    AP_UINT16      test_timer_retry;  /* TEST retry limit */
    AP_UINT16      ack_timeout;        /* acknowledgment timeout in ms */
    AP_UINT16      p_bit_timeout;     /* POLL response timeout in ms */
    AP_UINT16      t2_timeout;        /* acknowledgment delay in ms */
    AP_UINT16      rej_timeout;        /* REJ response timeout in seconds */
    AP_UINT16      busy_state_timeout; /* remote busy timeout in seconds */
    AP_UINT16      idle_timeout;       /* idle RR interval in seconds */
    AP_UINT16      max_retry;          /* retry limit for any response */
} LLC_LINK_SPEC_DATA;

```

DLC-specific data for Enterprise Extender (HPR/IP):

```

typedef struct ipdlc_link_spec_data
{
    V0_MUX_INFO    mux_info;           /* streams information */
    AP_UINT16      ack_timeout;        /* ACK timer for command frames */
    AP_UINT16      max_retry;          /* Retry limit for command frames */
    AP_UINT16      liveness_timeout;   /* Liveness timer */
    unsigned char  short_hold_mode;    /* Run in short-hold mode */
    unsigned char  remote_hostname[255]; /* Name of remote host to contact */
} IPDLC_LINK_SPEC_DATA;

```

Data for all DLC types:

```

typedef struct v0_mux_info
{
    AP_UINT16      dlc_type;           /* DLC implementation type */
    unsigned char  need_vrfy_fixup;    /* reserved */
    unsigned char  num_mux_ids;        /* reserved */
    AP_UINT32      card_type;          /* type of adapter card */
    AP_UINT32      adapter_number;     /* DLC adapter number */
    AP_UINT32      oem_data_length;    /* reserved */
}

```

## DEFINE\_LS

```
    AP_INT32      mux_ids[5];          /* reserved          */
} V0_MUX_INFO;
```

For Token Ring or Ethernet, the *address* parameter in the `link_address` structure is replaced by the following:

```
typedef struct tr_address
{
    unsigned char  mac_address[6];     /* MAC address        */
    unsigned char  lsap_address;       /* local SAP address   */
} TR_ADDRESS;
```

For Enterprise Extender (HPR/IP), the *address* parameter in the `link_address` structure is replaced by the following:

```
typedef struct ip_address_info
{
    unsigned char  lsap;                /* Local Service Access Point addr */
    unsigned char  version;             /* IPv4 or IPv6                */
    unsigned char  address[272];       /* reserved                      */
} IP_ADDRESS_INFO;
```

## Supplied parameters

The application supplies the following parameters:

### ***opcode***

AP\_DEFINE\_LS

### ***ls\_name***

Name of link station. This is an 8-byte ASCII string, padded on the right with spaces if the name is shorter than 8 bytes.

### ***def\_data.description***

A null-terminated text string (0-31 characters followed by a null character) describing the LS. This string is for information only; it is stored in the node's configuration file and returned on the QUERY\_LS, QUERY\_PU, and QUERY\_DOWNSTREAM\_PU verbs, but CS/AIX does not make any other use of it.

### ***def\_data.initially\_active***

Specifies whether this LS is automatically started when the node is started. Possible values are:

#### **AP\_YES**

The LS is automatically started when the node is started.

#### **AP\_NO**

The LS is not automatically started; it must be started manually.

If the LS is a leased SDLC link or a QLLC PVC link, you are recommended to set this parameter to AP\_YES to ensure that the link is always available.

### ***def\_data.react\_timer***

Reactivation timer for reactivating a failed LS. If the *react\_timer\_retry* parameter below is nonzero, to specify that CS/AIX should retry activating the LS if it fails, this parameter specifies the time in seconds between retries. When the LS fails, or when an attempt to reactivate it fails, CS/AIX waits for the specified time before retrying the activation. If *react\_timer\_retry* is zero, this parameter is ignored.

### ***def\_data.react\_timer\_retry***

Retry count for reactivating a failed LS. This parameter is used to specify whether CS/AIX should attempt to reactivate the LS if it fails while in use (or if an attempt to start the LS fails).

Specify zero to indicate that CS/AIX should not attempt to reactivate the LS, or specify the number of retries to be made. A value of 65,535 indicates that CS/AIX should retry indefinitely until the LS is activated.

CS/AIX waits for the time specified by the *react\_timer* parameter above between successive retries. If the retry count is reached without successfully reactivating the LS, or if a STOP\_LS is issued while

CS/AIX is retrying the activation, no further retries are made; the LS remains inactive unless START\_LS is issued for it.

If the *auto\_act\_supp* parameter is set to AP\_YES, the reactivation timer fields are ignored; if the link fails, CS/AIX does not attempt to reactivate it until the user application that was using the session attempts to restart the session.

If the LS is a leased SDLC link or a QLLC PVC link, you are recommended to set this parameter to a non-zero value to ensure that the link is always available.

#### ***def\_data.restart\_on\_normal\_deact***

Specifies whether CS/AIX should attempt to reactivate the LS if it is deactivated normally by the remote system. Possible values are:

##### **AP\_YES**

If the remote system deactivates the LS normally, CS/AIX attempts to reactivate it, using the same retry timer and count values as for reactivating a failed LS (the *react\_timer* and *react\_timer\_retry* parameters above).

##### **AP\_NO**

If the remote system deactivates the LS normally, CS/AIX does not attempt to reactivate it.

If the LS is a host link (specified by the *def\_data.adj\_cp\_type* parameter), or is automatically started when the node is started (the *initially\_active* parameter is set to AP\_YES), this parameter is ignored; CS/AIX always attempts to reactivate the LS if it is deactivated normally by the remote system (unless *react\_timer\_retry* is zero).

#### ***def\_data.port\_name***

Name of port associated with this link station. This is an 8-byte ASCII string, padded on the right with spaces if the name is shorter than 8 bytes, which must match the name of a defined port.

#### ***def\_data.adj\_cp\_name***

Fully qualified name of the adjacent CP for this LS.

If the *adj\_cp\_type* parameter below is set to AP\_NETWORK\_NODE or AP\_END\_NODE, and preassigned TG numbers are being used, set this parameter to the CP name defined at the adjacent node; if the adjacent node sends a CP name during XID exchange, it will be checked against this value.

If *adj\_cp\_type* is set to AP\_BACK\_LEVEL\_LEN\_NODE, CS/AIX uses this value only as an identifier; set it to any string (of the format described below) that does not match other CP names defined at this node.

If *adj\_cp\_type* is set to any other value, or if preassigned TG numbers are not being used, there is no need to specify this parameter; CS/AIX will check the CP name only if one is specified.

The name is a 17-byte EBCDIC string, padded on the right with EBCDIC spaces. It consists of a network ID of 1-8 A-string characters, an EBCDIC dot (period) character, and a network name of 1-8 A-string characters.

#### ***def\_data.adj\_cp\_type***

Adjacent node type.

If the adjacent node is an APPN node, and preassigned TG numbers are not being used, this is normally set to AP\_APPN\_NODE, indicating that the node type is unknown; CS/AIX will determine the type during XID exchange.

If preassigned TG numbers are being used, you must specify the node type explicitly. You can also specify it as an additional security check if preassigned TG numbers are not being used. In this case, CS/AIX will reject a connection attempt from the adjacent node if its node type does not match the one specified here. Use one of the following values:

##### **AP\_APPN\_NODE**

The node type is unknown. CS/AIX will determine the type during XID exchange.

##### **AP\_END\_NODE**

End node, Branch Network Node acting as an End Node from the local node's perspective, or up-level LEN node (one that includes the Network Name CV in its XID3).

## DEFINE\_LS

### **AP\_NETWORK\_NODE**

Network node, or Branch Network Node acting as a Network Node from the local node's perspective.

If the adjacent node is not an APPN node, use one of the following values. These values are not valid for an Enterprise Extender link, which must be to an APPN node.

### **AP\_BACK\_LEVEL\_LEN\_NODE**

Back-level LEN node (one that does not include the Network Name CV in its XID3).

### **AP\_HOST\_XID3**

Host node; CS/AIX should respond to a polling XID from the node with a format 3 XID.

### **AP\_HOST\_XID0**

Host node; CS/AIX should respond to a polling XID from the node with a format 0 XID.

### **AP\_DSPU\_XID**

Downstream PU; CS/AIX should include XID exchange in link activation. The *dspu\_name* and *dspu\_services* fields must also be set.

### **AP\_DSPU\_NOXID**

Downstream PU; CS/AIX should not include XID exchange in link activation. The *dspu\_name* and *dspu\_services* fields must also be set.

If you want to run independent LU 6.2 traffic over this LS, you must set the *adj\_cp\_type* parameter to AP\_APPN\_NODE, AP\_END\_NODE, AP\_NETWORK\_NODE, or AP\_BACK\_LEVEL\_LEN\_NODE.

### ***def\_data.dest\_address.format***

The type of link address specified. Possible values:

#### **AP\_IP\_ADDRESS\_INFO**

IP address. Specify this value for an Enterprise Extender (HPR/IP) link.

#### **AP\_UNSPECIFIED**

Unspecified address format. Specify this value for any link type other than Enterprise Extender (HPR/IP).

### ***def\_data.dest\_address.length***

Length of the destination address field, as specified in the following parameter or parameters.

For Enterprise Extender (HPR/IP), this parameter and *dest\_address.address* are reserved. Instead, you specify the address using the *remote\_hostname* parameter in the link-specific data.

For SDLC:

### ***def\_data.dest\_address.address***

Address of the secondary station on this LS.

- If the port that owns this LS is used only for incoming calls (*out\_link\_act\_lim* on DEFINE\_PORT is zero), this parameter is reserved.
- If the port that owns this LS is switched primary and is used for outgoing calls (*port\_type* is AP\_SWITCHED, *ls\_role* is AP\_LS\_PRI, and *out\_link\_act\_lim* on DEFINE\_PORT is nonzero), either set this parameter to 0xFF to accept whatever address is configured at the secondary station, or set it to a 1-byte value in the range 0x01-0xFE which must match the value configured at the secondary station.
- Otherwise, set it to a 1-byte value in the range 0x01-0xFE to identify the link station. If the port is primary multi-drop (*ls\_role* on DEFINE\_PORT is AP\_LS\_PRI and *tot\_link\_act\_lim* is greater than 1), this address must be different for each LS on the port.

For QLLC:

### ***def\_data.dest\_address.address***

Address of the destination node for this LS. This parameter is used only for SVC outgoing calls (defined by the *vc\_type* parameter in the link-specific data, and by the link activation limit parameters on DEFINE\_PORT); it is ignored for incoming calls or for PVC.

The address is a string of 1-14 characters. The address is in X.25 (1980) format; later address formats are not supported.

For Token Ring, Ethernet:

***def\_data.dest\_address.mac\_address***

MAC address of adjacent node.

If you need to define a non-selective listening LS (one that can be used only for incoming calls, but can have LUs defined on it to support dependent LU traffic), set this parameter to a null string. The LS can then be used to receive incoming calls from any remote link station, but cannot be used for outgoing calls. There is no need to define a non-selective listening LS if only independent LU traffic is used, because an LS for independent LU traffic can be set up dynamically when required.

If the local and adjacent nodes are on LANs of different types (one Token Ring, the other Ethernet) connected by a bridge, you will probably need to reverse the bit order of the bytes in the MAC address. For more information, see [“Bit ordering in MAC addresses”](#) on page 125. If the two nodes are on the same LAN, or on LANs of the same type connected by a bridge, no change is required.

***def\_data.dest\_address.lsap\_address***

Local SAP address of adjacent node. This must be a multiple of 0x02.

For Enterprise Extender (HPR/IP):

***def\_data.dest\_address.ip\_address\_info.lsap***

For Enterprise Extender: Local SAP address of the port. Specify a multiple of 0x04 in the range 0x04-0xEC. The usual value is 0x04, but VTAM may use 0x08 in some circumstances.

If you need to use two or more ports with different LSAP addresses on the same TCP/IP interface, you will need to create two or more Enterprise Extender DLCs, and then create a separate Enterprise Extender port for each DLC with the same *if\_name* but a different LSAP address.

***def\_data.dest\_address.ip\_address\_info.version***

For Enterprise Extender: Specifies whether the following field represents an IPv4 or IPv6 address. Possible values:

**IP\_VERSION\_4\_HOSTNAME**

The *address* field specifies an IPv4 address, or a hostname or alias that resolves to an IPv4 address.

**IP\_VERSION\_6\_HOSTNAME**

The *address* field specifies an IPv6 address, or a hostname or alias that resolves to an IPv6 address.

For all link types:

***def\_data.auto\_act\_supp***

Specifies whether the link can be activated automatically when required by a session. Possible values are:

**AP\_YES**

The link can be activated automatically.

**AP\_NO**

The link cannot be activated automatically.

If this parameter is set to AP\_YES:

- The reactivation timer fields are ignored. If the LS fails, CS/AIX does not attempt to reactivate it until a dependent LU application that was using the session attempts to restart the session; an LS used by independent LUs will not be reactivated by CS/AIX, and must be restarted manually.
- If the link is to an APPN node, the LS must have a preassigned TG number defined (see the following parameter), and *cp\_cp\_sess\_support* must be set to AP\_NO.
- If either the local node or the adjacent node is an end node, the LS must also be defined as auto-activatable at the adjacent node.

***def\_data.tg\_number***

Preassigned TG number. This parameter is used only if the adjacent node is an APPN node (*adj\_cp\_type* is either AP\_NETWORK\_NODE or AP\_END\_NODE); it is ignored otherwise.

This TG number is used to represent the link when the link is activated. The node will not accept any other number from the adjacent node during activation of this link; if the adjacent node is using preassigned TG numbers, the same TG number must be defined by the adjacent node on the adjacent link station.

If the local node is a LEN node, or if the adjacent node is a LEN node and the link is to be auto-activatable, set the TG number to 1. Otherwise, specify a number in the range 1-20, or zero to indicate that the TG number is not preassigned and is negotiated when the link is activated.

If a preassigned TG number is defined, the *adj\_cp\_name* parameter must also be defined, and the *adj\_cp\_type* parameter must be set to either AP\_END\_NODE or AP\_NETWORK\_NODE.

***def\_data.limited\_resource***

Specifies whether this link station is to be deactivated when there are no sessions using the link. Link stations on a nonswitched port cannot be configured as limited resource. Possible values are:

**AP\_NO**

The link is not a limited resource and will not be deactivated automatically.

**AP\_NO\_SESSIONS**

The link is a limited resource and will be deactivated automatically when no active sessions are using it.

**AP\_INACTIVITY**

The link is a limited resource and will be deactivated automatically when no active sessions are using it, or when no data has flowed on the link for the time period specified by the *link\_deact\_timer* field.

- If no SSCP-PU session is active across the link, the node deactivates the link immediately.
- If an SSCP-PU session is active but no traffic has flowed for the specified time period, the node sends REQDISCONT(normal) to the host. The host is then responsible for deactivating all LUs and the PU, at which time the local node will deactivate the link. However, the host may not deactivate LUs with active PLU-SLU sessions; in this case, the link remains active until all these sessions are deactivated (for example by the user logging out). This behavior can be changed by using options in the *ptf* field of the DEFINE\_NODE verb.

A limited resource link station may be configured for CP-CP session support, by setting this field to AP\_NO\_SESSIONS and *cp\_cp\_sess\_support* to AP\_YES. In this case, if CP-CP sessions are brought up over the link, CS/AIX will not treat the link as a limited resource (and so will not deactivate it).

***def\_data.solicit\_sscp\_sessions***

For an Enterprise Extender (HPR/IP) port, this parameter is reserved.

Specifies whether to request the adjacent node to initiate sessions between the SSCP and the local CP and dependent LUs. This parameter is used only if the adjacent node is an APPN node (*adj\_cp\_type* is either AP\_NETWORK\_NODE or AP\_END\_NODE); it is ignored otherwise. If the adjacent node is a host (*adj\_cp\_type* is either AP\_HOST\_XID3 or AP\_HOST\_XID0), CS/AIX always requests the host to initiate SSCP sessions.

Possible values are:

**AP\_YES**

Request the adjacent node to initiate SSCP sessions.

**AP\_NO**

Do not request the adjacent node to initiate SSCP sessions.

If the adjacent node is an APPN node and *dspu\_services* is set to a value other than AP\_NONE, this parameter must be set to AP\_NO.

***def\_data.pu\_name***

For an Enterprise Extender (HPR/IP) port, this parameter is reserved.



Name of the local PU that uses this link. This parameter is used only if *adj\_cp\_type* is set to AP\_HOST\_XID3 or AP\_HOST\_XID0, or if *solicit\_sscp\_sessions* is set to AP\_YES; it is ignored otherwise. This is an 8-byte alphanumeric type-A EBCDIC string (starting with a letter), padded on the right with EBCDIC spaces.

#### ***def\_data.disable\_remote\_act***

Specifies whether to prevent activation of the LS by the remote node. Possible values are:

##### **AP\_YES**

The LS can only be activated by the local node; if the remote node attempts to activate it, CS/AIX will reject the attempt.

##### **AP\_NO**

The LS can be activated by the remote node.

#### ***def\_data.dspu\_services***

For an Enterprise Extender (HPR/IP) port, this parameter is reserved.

Specifies the services which the local node will provide to the downstream PU across this link. This parameter is used only if the adjacent node is a downstream PU or an APPN node with *solicit\_sscp\_sessions* set to AP\_NO; it is reserved otherwise. Possible values are:

##### **AP\_PU\_CONCENTRATION**

Local node will provide SNA gateway for the downstream PU. The local node must be defined to support SNA gateway.

##### **AP\_DLUR**

Local node will provide DLUR services for the downstream PU. The local node must be defined to support DLUR. (Not supported on end node.)

##### **AP\_NONE**

Local node will provide no services for this downstream PU.

#### ***def\_data.dspu\_name***

For an Enterprise Extender (HPR/IP) port, this parameter is reserved.

Name of the downstream PU. The name is an 8-byte type-A EBCDIC string (starting with a letter), padded to the right with EBCDIC spaces.

This parameter is required when both of the following conditions are true; otherwise, it is reserved:

- The *solicit\_sscp\_sessions* parameter is set to AP\_NO
- The *dspu\_services* parameter is set to AP\_PU\_CONCENTRATION or AP\_DLUR

If the downstream PU is used for DLUR, this name should match the PU name configured on the host. (CS/AIX sends both the PU name and PU ID to the host to identify the PU. The host normally identifies the PU by its PU name, or by the PU ID if it cannot find a matching PU name.)

#### ***def\_data.dlus\_name***

For an Enterprise Extender (HPR/IP) port, this parameter is reserved.

Name of the DLUS node from which DLUR solicits SSCP services when the link to the downstream node is activated. This field is reserved if *dspu\_services* is not set to AP\_DLUR.

The name is a 17-byte EBCDIC string, right-padded with EBCDIC spaces. It consists of a network ID of up to 8 A-string characters, an EBCDIC dot (period) character, and a network name of up to 8 A-string characters.

To specify the global default DLUS, defined using the DEFINE\_DLUR\_DEFAULTS verb, set this parameter to 17 binary zeros. If this parameter is set to zeros and there is no global default DLUS, then DLUR will not initiate SSCP contact when the link is activated.

#### ***def\_data.bkup\_dlus\_name***

For an Enterprise Extender (HPR/IP) port, this parameter is reserved.

Name of the backup DLUS node from which DLUR solicits SSCP services if the node specified by *dlus\_name* is not active. This field is reserved if *dspu\_services* is not set to AP\_DLUR.

## DEFINE\_LS

The name is a 17-byte EBCDIC string, right-padded with EBCDIC spaces. It consists of a network ID of up to 8 A-string characters, an EBCDIC dot (period) character, and a network name of up to 8 A-string characters.

To specify the global backup default DLUS, defined using the DEFINE\_DLUR\_DEFAULTS verb, set this parameter to 17 binary zeros.

### ***def\_data.hpr\_supported***

Specifies whether HPR is supported on this link. If the link is an Enterprise Extender (HPR/IP) link, this parameter must be set to AP\_YES. Otherwise, it must be set to AP\_NO unless the *adj\_cp\_type* parameter indicates that the link connects to an APPN node. Possible values are:

#### **AP\_YES**

HPR is supported on this link.

#### **AP\_NO**

HPR is not supported on this link.

### ***def\_data.hpr\_link\_lvl\_error***

Specifies whether HPR traffic should be sent on this link using link-level error recovery. This parameter is ignored unless *hpr\_supported* is set to AP\_YES.

This parameter is reserved for SDLC / Enterprise Extender (HPR/IP) links.

Possible values are:

#### **AP\_YES**

HPR traffic should be sent on this link using link-level error recovery.

#### **AP\_NO**

HPR traffic should not be sent on this link using link-level error recovery.

### ***def\_data.link\_deact\_timer***

Limited resource link deactivation timer, in seconds. A limited resource link is automatically deactivated if no data flows over the link for the time specified by this parameter. This parameter is not used if *limited\_resource* is set to any value other than INACTIVITY.

The minimum value is 5; values in the range 1-4 will be interpreted as 5.

The value 0 (zero) indicates one of the following:

- If the *hpr\_supported* parameter is set to AP\_YES, the default deactivation timer value of 30 is used.
- If the *hpr\_supported* parameter is set to AP\_NO, no timeout is used (the link is not deactivated, as if *limited\_resource* were set to AP\_NO).

### ***def\_data.default\_nn\_server***

End node: Specifies whether this is a link supporting CP-CP sessions to a network node that can act as the local node's network node server. When the local node has no CP-CP sessions to a network node server and needs to establish them, it checks this parameter on its defined LSs to find a suitable LS to activate. This allows you to specify which adjacent NNs are suitable to act as the NN server (for example, to avoid using NNs that are accessed by expensive or slow links).

Possible values are:

#### **AP\_YES**

This link supports CP-CP sessions to a network node that can act as the local node's NN server; the local node can automatically activate this link if it needs to contact an NN server. The *cp\_cp\_sess\_support* parameter must be set to AP\_YES.

#### **AP\_NO**

This link should not be automatically activated in an attempt to contact a network node server.

If the local node is not an end node, this parameter is ignored.

### ***def\_data.ls\_attributes***

This array contains further information about the adjacent node, as described in the following parameters:

***def\_data.ls\_attributes[0]***

Host type. Set this to AP\_SNA unless you are communicating with a host of one of the other types listed below. Possible values are:

**AP\_SNA**

Standard SNA host.

**AP\_FNA**

Fujitsu Network Architecture (VTAM-F) host.

**AP\_HNA**

Hitachi Network Architecture host.

***def\_data.ls\_attributes[1]***

Network Name CV suppression for a link to a back-level LEN node.

If *adj\_cp\_type* is set to AP\_BACK\_LEVEL\_LEN\_NODE or AP\_HOST\_XID3, specify whether to suppress inclusion of the Network Name CV in the format 3 XID sent to the LEN node, using one of the following values:

**AP\_NO**

Include the Network Name CV in the XID.

**AP\_SUPPRESS\_CP\_NAME**

Do not include the Network Name CV.

If *adj\_cp\_type* is set to any other value, this parameter is ignored.

***def\_data.adj\_node\_id***

Node ID of adjacent node. This is a 4-byte hexadecimal string, consisting of a block number (three hexadecimal digits) and a node number (five hexadecimal digits). Set it to zeros to disable node ID checking. If this link station is defined on a switched port, the *node\_id* must be unique, and there may only be one null *node\_id* on each switched port.

***def\_data.local\_node\_id***

Node ID sent in XIDs on this LS. This is a 4-byte hexadecimal string, consisting of a block number (3 hexadecimal digits) and a node number (5 hexadecimal digits). Set it to zeros to use the node ID specified in the DEFINE\_NODE verb.

***def\_data.cp\_cp\_sess\_support***

Specifies whether CP-CP sessions are supported. This parameter is valid only if the adjacent node is an end node or network node (*adj\_cp\_type* is AP\_NETWORK\_NODE, AP\_END\_NODE, or AP\_APPN\_NODE); it is ignored otherwise. If both the local node and the adjacent node are network nodes, this parameter should be set to AP\_YES in order to use APPN functions between these nodes.

Possible values are:

**AP\_YES**

CP-CP sessions are supported.

**AP\_NO**

CP-CP sessions are not supported.

***def\_data.use\_default\_tg\_chars***

Specifies whether the default TG characteristics supplied on the DEFINE\_PORT verb should be used. The TG characteristics apply only if the link is to an APPN node; this parameter, and the parameters in the *tg\_chars* structure, are ignored otherwise. Possible values are:

**AP\_YES**

Use the default TG characteristics; ignore the *tg\_chars* structure on this verb.

**AP\_NO**

Use the *tg\_chars* structure on this verb.

***def\_data.tg\_chars.effect\_cap***

Actual bits per second rate (line speed). The value is encoded as a 1-byte floating point number, represented by the formula  $0.1 \text{ mmm} * 2^{\text{eeee}}$  where the bit representation of the byte is 'eeeeemmm'. Each unit of effective capacity is equal to 300 bits per second.

For an Ethernet or Enterprise Extender (HPR/IP) link, ensure that you set this parameter to the true 'effective capacity' of the link, including any step-downs or bottlenecks in the path, and not just to the theoretical capacity of the adapter used by the link. For example, a GigE adapter may be capable of processing one gigabit, but if the link goes through an ethernet switch to a target box that uses FastEthernet you should specify 100MBps or less.

***def\_data.tg\_chars.connect\_cost***

Cost per connect time. Valid values are integer values in the range 0-255, where 0 is the lowest cost per connect time and 255 is the highest.

***def\_data.tg\_chars.byte\_cost***

Cost per byte. Valid values are integer values in the range 0-255, where 0 is the lowest cost per byte and 255 is the highest.

***def\_data.tg\_chars.security***

Security level of the network. Possible values are:

**AP\_SEC\_NONSECURE**

No security.

**AP\_SEC\_PUBLIC\_SWITCHED\_NETWORK**

Data is transmitted over a public switched network.

**AP\_SEC\_UNDERGROUND\_CABLE**

Data is transmitted over secure underground cable.

**AP\_SEC\_SECURE\_CONDUIT**

Data is transmitted over a line in a secure conduit that is not guarded.

**AP\_SEC\_GUARDED\_CONDUIT**

Data is transmitted over a line in a conduit that is protected against physical tapping.

**AP\_SEC\_ENCRYPTED**

Data is encrypted before transmission over the line.

**AP\_SEC\_GUARDED\_RADIATION**

Data is transmitted over a line that is protected against physical and radiation tapping.

***def\_data.tg\_chars.prop\_delay***

Propagation delay: the time that a signal takes to travel the length of the link. Specify one of the following values, according to the type of link:

**AP\_PROP\_DELAY\_MINIMUM**

Minimum propagation delay.

**AP\_PROP\_DELAY\_LAN**

Delay is less than 480 microseconds (typical for a LAN).

**AP\_PROP\_DELAY\_TELEPHONE**

Delay is in the range 480-49,512 microseconds (typical for a telephone network).

**AP\_PROP\_DELAY\_PKT\_SWITCHED\_NET**

Delay is in the range 49,512-245,760 microseconds (typical for a packet-switched network).

**AP\_PROP\_DELAY\_SATELLITE**

Delay is greater than 245,760 microseconds (typical for a satellite link).

**AP\_PROP\_DELAY\_MAXIMUM**

Maximum propagation delay.

***def\_data.tg\_chars.user\_def\_parm\_1 through def\_data.tg\_chars.user\_def\_parm\_3***

User-defined parameters, which you can use to include other TG characteristics not covered by the above parameters. Each of these parameters must be set to a value in the range 1-255.

***def\_data.target\_pacing\_count***

Numeric value between 1 and 32,767 inclusive indicating the desired pacing window size. (The current version of CS/AIX does not make use of this value.)

***def\_data.max\_send\_btu\_size***

Maximum BTU size that can be sent from this link station. This value is used to negotiate the maximum BTU size that a pair of link stations can use to communicate with each other. The value includes the length of the TH and RH (total 9 bytes) as well as the RU. Specify a value in the range 265-65535 (265-4105 for SDLC, 265-1496 for Ethernet, 265-17745 for Token Ring).

***def\_data.ls\_role***

Link station role. This is normally set to AP\_USE\_PORT\_DEFAULTS, specifying that the LS role is to be taken from the definition of the port that owns this LS.

If you need to override the port's LS role for an individual LS, specify one of the following values:

**AP\_LS\_PRI**

Primary

**AP\_LS\_SEC**

Secondary

**AP\_LS\_NEG**

Negotiable

For an Enterprise Extender (HPR/IP) port, you must use AP\_USE\_PORT\_DEFAULTS; you cannot override the port's LS role.

***def\_data.max\_ifrm\_rcvd***

The maximum number of I-frames that can be received by this link station before an acknowledgment is sent. Specify a value in the range 0-127. If 0 is specified, the value from the port definition is used.

***def\_data.dlus\_retry\_timeout***

For an Enterprise Extender (HPR/IP) port, this parameter is reserved.

Reactivation timer for contacting a DLUS. If CS/AIX fails to contact the DLUS, this parameter specifies the time in seconds between retries.

Specify a value in the range 0x0001-0xFFFF.

***def\_data.dlus\_retry\_limit***

For an Enterprise Extender (HPR/IP) port, this parameter is reserved.

The interval in seconds between the second and subsequent attempts to contact the DLUS specified by the *dlus\_name* and *bkup\_dlus\_name* parameters. Specify a value in the range 0x0001-0xFFFFE, or specify 0xFFFF to indicate that CS/AIX should retry indefinitely until it contacts the DLUS. The interval between the first and second attempts is always 1 second. If zero is specified, then the defaults specified using the DEFINE\_DLUR\_DEFAULTS verb are used. This parameter is ignored if the *dspu\_services* parameter is not set to AP\_DLUR.

***def\_data.conventional\_lu\_compression***

Specifies whether data compression is requested for LU 0-3 sessions on this link. This parameter is used only if this link carries LU 0-3 traffic; it does not apply to LU 6.2 sessions.

Possible values are:

**AP\_YES**

Data compression should be used for LU 0-3 sessions on this link if the host requests it.

**AP\_NO**

Data compression should not be used for LU 0-3 sessions on this link.

***def\_data.branch\_link\_type***

This parameter applies only if the local node is a Branch Network Node; it is reserved if the local node is any other type.

If the parameter *def\_data.adj\_cp\_type* is set to AP\_NETWORK\_NODE, AP\_END\_NODE, AP\_APPN\_NODE, or AP\_BACK\_LEVEL\_LEN\_NODE, this parameter defines whether the link is an uplink or a downlink.

Possible values are:

**AP\_UPLINK**

The link is an uplink.

**AP\_DOWNLINK**

The link is a downlink.

If *def\_data.adj\_cp\_type* is set to AP\_NETWORK\_NODE, this parameter must be set to AP\_UPLINK.

**def\_data.adj\_brnn\_cp\_support**

This parameter applies only if the local node is a Branch Network Node and the adjacent node is a network node (the parameter *def\_data.adj\_cp\_type* is set to AP\_NETWORK\_NODE, or it is set to AP\_APPN\_NODE and the node type discovered during XID exchange is network node). It is reserved if the local and remote nodes are any other type.

This parameter defines whether the adjacent node can be a Branch Network Node that is acting as a Network Node from the point of view of the local node. Possible values are:

**AP\_BRNN\_ALLOWED**

The adjacent node is allowed (but not required) to be a Branch Network Node.

**AP\_BRNN\_REQUIRED**

The adjacent node must be a Branch Network Node.

**AP\_BRNN\_PROHIBITED**

The adjacent node must not be a Branch Network Node.

If *def\_data.adj\_cp\_type* is set to AP\_NETWORK\_NODE and *auto\_act\_supp* is set to AP\_YES, this parameter must be set to AP\_BRNN\_REQUIRED or AP\_BRNN\_PROHIBITED.

**def\_data.pu\_can\_send\_dddlu\_offline**

Specifies whether the local PU should send NMVT (power off) messages to the host. If the host system supports DDDLU (Dynamic Definition of Dependent LUs), CS/AIX sends NMVT (power off) to the host when it has finished using a dynamically defined LU. This allows the host to save resources by removing the definition when it is no longer required.

This parameter is used only if this link is to a host (*solicit\_sscp\_sessions* is set to AP\_YES and *dspu\_services* is not set to AP\_NONE).

Possible values are:

**AP\_YES**

The local PU sends NMVT (power off) messages to the host.

**AP\_NO**

The local PU does not send NMVT (power off) messages to the host.

If the host supports DDDLU but does not support the NMVT (power off) message, this parameter must be set to AP\_NO.

**def\_data.link\_spec\_data\_len**

Length of the link-specific data. The data should be concatenated to the basic structure.

Link-specific data for SDLC:

**mux\_info.dlc\_type**

Type of the DLC. Set this to AP\_IMPL\_SDLC\_SL.

**contact\_timer**

Timeout required before a SNRM or XID is retransmitted in the event of nonacknowledgment (used for primary SDLC only). This value must be greater than the no response (T1) timeout value *no\_resp\_timer* described below. The timer is specified in milliseconds.

This timer is also used for special pre-activation polling.

**contact\_timer\_retry**

Number of times transmission and retransmission of a contact frame (such as SNRM) is allowed using the normal poll timer before CS/AIX changes to the slow poll timer.

A value of 0xFFFF indicates an unlimited retry count. A value of 0x0001 indicates that the switch to the slow poll should be made after the first timer expiry.

***contact\_timer2***

Slow poll contact timer in milliseconds. When the contact timer retry count expires, CS/AIX continues to poll using this timer. This prevents leased (multi-drop) links from being flooded by poll frames for absent stations.

***contact\_timer\_retry2***

The slow poll contact timer retry limit value corresponds to the number of times transmission and retransmission of a contact frame (such as SNRM) is allowed on the slow cycle before an outage message is sent to the DLC user.

A value of 0xFFFF indicates an unlimited retry count. A value of 0x0001 indicates that an outage should be generated after the first slow poll timer expiry.

***disc\_timer***

Timeout required before a DISC is retransmitted in the event of nonacknowledgment (used for primary SDLC only). The timer is specified in milliseconds.

***disc\_timer\_retry***

The Disconnect timer retry limit value corresponds to the number of times transmission and retransmission of a DISC is allowed.

A value of 0xFFFF indicates an unlimited retry count. A value of 0x0001 indicates that an outage should be generated after the first timer expiry.

***nve\_poll\_timer***

Timeout required before an adjacent secondary station (which has previously been removed from the polling list because it has no data to send) is reinserted into the polling list. The timer is specified in milliseconds.

***nve\_poll\_timer\_retry***

Number of times a station is removed from the polling list on the normal poll timer before CS/AIX switches to using the slow poll timer.

A value of 0xFFFF indicates an unlimited retry count. A value of 0x0001 indicates that the switch to the slow poll should be made after the first timer expiry.

***nve\_poll\_timer2***

The slow negative poll timer in milliseconds. When the negative poll timer retry count expires, CS/AIX continues to poll using this timer. This prevents leased (multi-drop) links from being flooded by poll frames for idle stations.

***nve\_poll\_timer\_retry2***

Number of times a station is removed from the polling list on the slow poll cycle before an outage message is sent to the HLS. Specify a value in the range 1-65,535. This value is normally set to 0xFFFF, indicating infinite retry.

***no\_resp\_timer***

The maximum time a primary station waits (after having sent a frame with a poll bit) for a response frame before trying to poll another station. This timer is restarted when a frame without the F-bit is received and stopped only when a frame with an F-bit is received. The timeout should be set to a value not less than twice the transmission time for the longest I-frame plus adjacent station frame processing time.

The timer is specified in milliseconds.

***no\_resp\_timer\_retry***

Number of times an adjacent secondary station is seen to fail to respond before the primary sends an outage message to the DLC user.

A value of 0xFFFF indicates an unlimited retry count. A value of 0x0001 indicates that an outage should be generated after the first timer expiry.

***rem\_busy\_timer***

Time allowed for an adjacent secondary station to be in an RNR condition. This is used in conjunction with the retry limit value to provide the overall time before an outage message is sent. The timer is specified in milliseconds.

***rem\_busy\_timer\_retry***

Used in conjunction with the timeout value to provide the overall timeout before an outage message is sent.

A value of 0xFFFF is used to indicate an unlimited retry count. A value of 0x0001 indicates that an outage should be generated after the first timer expiry.

***re\_tx\_threshold***

Maximum percentage of I-frames that may be retransmitted before a temporary transmission error is triggered. Valid values are in the range 0-100. A value of 0 is mapped to 20 percent.

***repoll\_threshold***

The maximum percentage polls that may be retried by the local primary link station before a temporary transmission error is triggered. Valid values are in the range 0-100. A value of 0 is mapped to a default which varies according to the details of the link. For incoming links, the default is 10 percent. For outgoing links, the default is 100, unless the *no\_resp\_timer\_retry* value is between 1 and 100, in which case the value of *no\_resp\_timer\_retry* is used.

***rr\_timer***

The time in milliseconds to wait before turning the poll bit around when the SDLC component has no work to do.

This field may be set to zero, or to a nonzero value if the immediate turn-around causes hardware problems on the link. Higher values can also be used to optimize link usage, because often the higher-level software will generate data in response to the data contained in an I-frame carrying the poll bit; the pause allows the data to be received and processed.

***poll\_frame***

The frame to use for pre-activation polling. This is normally XID, indicating that polling is in the control of the DLC user. However, when CS/AIX is primary talking to an old secondary implementation, it may be necessary to poll using some other frame. Possible values are: XID, DISC, SNRM, SNRME, TEST.

***poll\_on\_iframe***

Specifies whether this link station is permitted to send the poll bit on an I-frame. This allows CS/AIX to work with certain SDLC implementations which do not handle receipt of I-frames carrying the poll bit.

Possible values are:

**AP\_YES**

This link station is allowed to send the poll bit on an I-frame.

**AP\_NO**

This link station is not allowed to send the poll bit on an I-frame.

***stub\_spec\_data\_len***

Length of the Stub specific data that follows. Set this to size of (STUB\_SPEC\_DATA).

***stub\_spec\_data***

Stub specific data. These fields are used only for switched outgoing links. The values specified in this structure override those defined in the Stub specific data for the port that owns this LS; where fields in this structure are shown as reserved, the values from the port are used instead. For switched incoming links or leased links, the parameters defined in the Stub specific data for the port (not for the LS) are used.

The structure contains the following fields:

***stub\_spec\_data.opt1***

HMOD port options flag 1. Set the appropriate bits of this field as follows (bit 7 is the most significant bit):

***bit 7***

4-wire connection (2 wire connection if not set).

***bit 6***

Use NRZI (NRZ if not set)



The remaining bits are reserved.

***stub\_spec\_data.opt2***

Reserved.

***stub\_spec\_data.linesp***

The line speed for the line used on this port. For example, 2400 (0x00000960) for a 2400 baud line. Valid values are in the range 600-38,400 baud. The exact meaning of this parameter depends on the value set on the *physical\_link* parameter.

- If *physical\_link* is set to SDLC\_PL\_X21, then the *stub\_spec\_data.linesp* parameter is ignored.
- If *physical\_link* is set to SDLC\_PL\_V25 or SDLC\_PL\_SMART\_MODEM, then the value of the *stub\_spec\_data.linesp* parameter is the speed at which the dial string is sent to the modem.
  - If *physical\_link* is set to any other value, then the value of the *stub\_spec\_data.linesp* parameter is the speed of data transfer, only valid if external clocking is specified.

***stub\_spec\_data.rcv\_pool\_size***

Reserved.

***stub\_spec\_data.poll\_wait***

Reserved.

***stub\_spec\_data.hmod\_data\_len***

Length of the dial data string that follows (in the *hmod\_data* parameter). If no dial data is specified, set this parameter to zero.

***stub\_spec\_data.hmod\_data***

Dial data for outgoing calls. This parameter applies only to switched links; it is reserved if the port associated with this LS is defined to be nonswitched.

This is an ASCII string, specifying the dial data to be passed to the modem to initiate the call.

The dial data may need to contain non-printable control characters; for example, it may have to be terminated with a carriage return, equivalent to pressing the Enter key. In this case, include the hexadecimal value of the control character in the string (for example, 0x0D for a carriage return). For details of the hexadecimal values you can use to represent control characters, see [“Modem control characters”](#) on page 126.

Support for dial data depends on the SDLC adapter and modem that you are using; if they do not support dial data, set this parameter to a null string.

***stub\_spec\_data.x21\_sequence***

X21 selection sequence to identify the remote link station. This parameter is only valid if *physical\_link* is set to SDLC\_PL\_X21. This string is limited to digits 0-9 and characters \* (asterisk), + (plus), - (hyphen), . (period) and / (slash). The string must end with + (plus sign). If the string is less than 255 characters long, then it must be null-terminated.

***stub\_spec\_data.x21\_retry\_count***

Number of times that an unsuccessful X21 call may be retried before it is abandoned. This parameter is only valid if *physical\_link* is set to SDLC\_PL\_X21. Valid values are in the range 0-15.

***stub\_spec\_data.x21\_retry\_delay***

Delay, in tenths of a second, before retrying an unsuccessful X21 call. This parameter is only valid if *physical\_link* is set to SDLC\_PL\_X21. Valid values are in the range 0-1200.

***stub\_spec\_data.v25\_tx\_delay***

Amount of time, in tenths of a second, that elapses between sending the DTR (data terminal ready) signal and transmitting a dial string to the modem. This parameter is only valid if *physical\_link* is set to SDLC\_PL\_V25. Valid values are in the range 0-600, which is equal to 0.1 seconds to 1 minute. A value of 0 is treated as 0.1 seconds.

***stub\_spec\_data.cdctl***

Connect Data Set to Line (CDSTL) indicates that Data Terminal Ready (DTR) should not be enabled until after Ring Indicate (RI) has occurred. This parameter is only valid if *physical\_link* is set to SDLC\_PL\_X21. Possible values are:

## DEFINE\_LS

### **AP\_YES**

Do not enable DTR until RI has been signaled.

### **AP\_NO**

Enable DTR without waiting for RI.

Link-specific data for QLLC:

### ***mux\_info.dlc\_type***

Type of the DLC. Set this to AP\_IMPL\_NLI\_QLLC.

### ***vc\_type***

The Virtual Circuit type of the LS. Possible values are:

#### **VQL\_SVC**

Switched Virtual Circuit

#### **VQL\_PVC**

Permanent Virtual Circuit

If you define both SVC and PVC LSs between the same local node and remote node, unpredictable results may occur if the SVC LS is started first (since it may not be possible to match the incoming call to the correct LS). To avoid these problems, ensure that PVC LSs are activated before any SVC LSs between the same pair of nodes.

### ***req\_rev\_charge***

Specifies whether X.25 should request reverse charging when attempting to contact the remote system using this LS. Possible values are:

#### **AP\_YES**

Request reverse charging.

#### **AP\_NO**

Do not request reverse charging. If the X.25 network does not support facilities negotiation, this parameter must be set to AP\_NO.

If the X.25 network does not support facilities negotiation, this parameter must be set to AP\_NO (also see the *fac* parameter below).

### ***loc\_packet***

Packet size used for sending data on switched virtual circuits from the local station to the remote station. This parameter is used only if the *vc\_type* parameter is set to VQL\_SVC. The packet size you specify is sent as an optional facility on the outgoing call.

The actual size used is 2 to the power of *loc\_packet*; for example, setting *loc\_packet* to 7 indicates a packet size of 2 to the power of 7, which is 128. To indicate using the default packet size for the network, set this parameter to zero. Check with the administrator of your X.25 network to determine the correct value to use.

### ***rem\_packet***

Packet size used for receiving data on switched virtual circuits from the remote station. This parameter is used only if the *vc\_type* parameter is set to VQL\_SVC. The packet size you specify is sent as an optional facility on the outgoing call.

The actual size used is 2 to the power of *rem\_packet* (as for *loc\_packet* above). To indicate using the default packet size for the network, set this parameter to zero. Check with the administrator of your X.25 network to determine the correct value to use.

### ***loc\_wsize***

Window size used for sending data from the local station to the remote station. Specify a value in the range 1-7, or zero to indicate using the default window size for the network. Check with the administrator of your X.25 network to determine the correct value to use.

### ***rem\_wsize***

Window size used for receiving data from the remote station. Specify a value in the range 1-7, or zero to indicate using the default window size for the network. Check with the administrator of your X.25 network to determine the correct value to use.

**retry\_limit**

Number of times to retry sending a QXID, QSM, or QDISC message if no response is received within the time specified by *retry\_timeout* below.

Range is 1-255. If *vc\_type* above is set to VQL\_PVC, this parameter is ignored for QXID messages; XID sending is retried indefinitely (so that an initially active LS can wait indefinitely for the remote station to become active).

**retry\_timeout**

Timeout in seconds for QXID, QSM, or QDISC messages. A message will be retried (up to the number of times specified by *retry\_limit* above) if no response is received within this time. Range is 1-255.

**idle\_timeout**

Timeout in seconds used to detect a completely idle line. This value is used during connect processing for SVCs when the local station is secondary and waiting for XIDs. If no message is received in this time, CS/AIX assumes that the remote station has failed.

Range is 1-255. This field is ignored if *vc\_type* above is set to VQL\_PVC.

**pvc\_id**

PVC identifier. Set this to a decimal number to identify which PVC (from the range of PVCs defined for your X.25 provider software) is to be used for this LS. This field is reserved if *vc\_type* above is set to VQL\_SVC.

**cud\_len**

Length of the Call User Data that follows (in the *cud* parameter).

**cud**

Call User Data: this parameter identifies the protocol to be used over the underlying X.25 virtual circuit, and is used only if the *vc\_type* parameter is set to VQL\_SVC. For most implementations, this should be set to a single hex byte, which is 0xC3 to request that the called node supports the 1980 QLLC level, or 0xCB to request 1984 support. Some remote systems may require additional bytes; check with the System Administrator of the remote system.

**rx\_thrput\_class**

Specifies the maximum line speed at which the calling DTE can receive data. Possible values are:

**VQL\_CLASS\_DEFAULT**

GDLC default throughput class

**VQL\_CLASS\_1200**

1200 bps throughput for received data

**VQL\_CLASS\_2400**

2400 bps throughput for received data

**VQL\_CLASS\_4800**

4800 bps throughput for received data

**VQL\_CLASS\_9600**

9600 bps throughput for received data

**VQL\_CLASS\_19200**

19,200 bps throughput for received data

**VQL\_CLASS\_48000**

48,000 bps throughput for received data.

**tx\_thrput\_class**

Specifies the maximum line speed at which the calling DTE can transmit data. Possible values are:

**VQL\_CLASS\_DEFAULT**

GDLC default throughput class

**VQL\_CLASS\_1200**

1200 bps throughput for transmitted data

**VQL\_CLASS\_2400**

2400 bps throughput for transmitted data

## DEFINE\_LS

### **VQL\_CLASS\_4800**

4800 bps throughput for transmitted data

### **VQL\_CLASS\_9600**

9600 bps throughput for transmitted data

### **VQL\_CLASS\_19200**

19,200 bps throughput for transmitted data

### **VQL\_CLASS\_48000**

48,000 bps throughput for transmitted data.

### ***cugo***

Specifies whether the call is made within a closed user group with outgoing access. Possible values are:

#### **AP\_YES**

The call is made within a closed user group with outgoing access.

#### **AP\_NO**

The call is not made within a closed user group with outgoing access.

### ***cug***

Specifies whether the link station is used by a closed user group. This parameter is valid only when *cugo* is set to AP\_YES. Possible values are:

#### **AP\_YES**

This link station is used by a closed user group. The group number is specified in *cug\_index*.

#### **AP\_NO**

This link station is not used by a closed user group.

### ***cug\_index***

Specify a 4-digit decimal integer that identifies the closed user group within which the call is to be placed. The network provider allocates identifying codes for any closed user groups to which you subscribe. This parameter is valid only if *cug* is set to AP\_YES. Specify a value in the range 0-9999.

### ***nuid\_length***

The length of the data supplied in *nuid\_data*. Specify a value in the range 0-109.

### ***nuid\_data***

The network user ID you want to supply to the network when the call is placed. The length of the data passed is specified in *nuid\_length*.

### ***rpoa\_count***

The number of RPOA (recognized private operating agency) codes specified in *rpoa\_ids*. Specify a value in the range 0-30.

### ***rpoa\_ids***

Array of RPOA (recognized private operating agency) codes identifying the RPOA transit network through an international gateway. The number of entries is specified by *rpoa\_count*. Specify a value in the range 0-30.

DLC-specific data for Token Ring, Ethernet:

### ***gdlc\_ls\_cfg.mux\_info.dlc\_type***

Type of the DLC. Possible values are:

#### **AP\_IMPL\_TR\_GDLC**

Token Ring

#### **AP\_IMPL\_ETHER\_GDLC**

Ethernet

### ***gdlc\_ls\_cfg.xid\_timeout***

Timeout required before an XID is retransmitted when trying to contact a remote station. The timer is specified in half-second increments (so a value of 8 indicates 4 seconds). Higher values may be needed if the remote station is on a separate Token Ring connected by a bridge.

***gdlc\_ls\_cfg.xid\_retry\_limit***

The XID retry limit value corresponds to the number of times transmission and retransmission of an XID is allowed. Higher values may be needed if the remote station is on a separate Token Ring connected by a bridge.

***gdlc\_ls\_cfg.t1\_timeout***

Timeout required before an I-frame is retransmitted if no response is received. The timer is specified in half-second increments (so a value of 8 indicates 4 seconds). Higher values may be needed if the remote station is on a separate Token Ring connected by a bridge.

***gdlc\_ls\_cfg.t1\_retry\_limit***

The T1 retry limit value corresponds to the number of times transmission and retransmission of an I-frame is allowed. The minimum is 1. Higher values may be needed if the remote station is on a separate Token Ring connected by a bridge.

***gdlc\_ls\_cfg.ack\_time***

Acknowledgment timeout: the maximum delay that can occur between receiving a frame and sending an acknowledgment for it. The timeout is specified in half-second increments; range is 1-255 (0.5 second-127.5 seconds).

***gdlc\_ls\_cfg.inact\_time***

Inactivity timeout: the local station assumes that it has lost connectivity to the remote station if no data is received within this time. The timeout is specified in seconds; range is 1-255.

***gdlc\_ls\_cfg.force\_time***

Force timeout: if no response to a normal disconnection is received in this time, the local station causes a forced disconnection. The timeout is specified in seconds; range is 1-16,383.

***gdlc\_ls\_cfg.uu.tr.pkt\_priority***

The ring access priority to be used for transmit packets. This parameter applies only to Token Ring; it is reserved for Ethernet.

Allowed values are in the range 0-3, where 0 is the lowest and 3 is the highest.

***gdlc\_ls\_cfg.uu.tr.dyna\_wnd***

Dynamic window increment. This parameter applies only to Token Ring; it is reserved for Ethernet.

The transmit window size is automatically reduced to 1 if packets are lost as a result of network congestion; this parameter specifies the number of packets that must be received successfully before the window can be increased. Each time the specified number of packets is received successfully, the window size is increased by 1.

***remote\_name***

If this link station calls or selectively listens for a partner link station, specify 1-8 locally displayable characters that identify the name of the partner link station. This name must match the name defined for the LS on the remote system.

***local\_name***

A unique name for the physical adapter that connects the local node to the network. This name must be unique throughout the network. Specify an 8-byte type-A EBCDIC string, padded to the right with EBCDIC spaces.

When you start the link, CS/AIX checks the network to ensure that the name you specified is not already in use by another node. If the name is already being used, CS/AIX generates an error message. You must change this parameter value to specify a name that is not already being used.

Link-specific data for Enterprise Extender (HPR/IP):

***ipdlc\_link\_spec\_data.mux\_info.dlc\_type***

Type of DLC. Set this to AP\_IP.

***ipdlc\_link\_spec\_data.ack\_timeout***

Duration for the acknowledgment timer (sometimes called the T1 timer): the time in milliseconds within which a response must be received for a command frame sent to the adjacent link station. If the response is not received within this time, a duplicate frame is sent.

## DEFINE\_LS

A lower value for this parameter means that lost packets will be detected quickly, but may increase network traffic.

Specify a value in the range 0-65535. This parameter should be set to a value greater than twice the expected network latency. A typical value is 10000 milliseconds.

### ***ipdlc\_link\_spec\_data.max\_retry***

The maximum number of times that the local station will retry sending a command frame. If this retry count is exceeded without receiving a response, the link is considered to have failed.

A lower value for this parameter means that link failures will be detected quickly, but may cause unnecessary reporting of link failures if a few packets are lost.

Specify a value in the range 0-255. A typical value is 10 retries.

### ***ipdlc\_link\_spec\_data.liveness\_timeout***

Duration for the liveness timer (sometimes called the TL timer): the time in milliseconds for which the link will be held active if there is no evidence that the remote station is still active.

A lower value for this parameter means that link failures will be detected quickly, but may increase network traffic on idle active links.

Specify a value in the range 1-65535 milliseconds. A typical value is 10000 (10 seconds).

### ***ipdlc\_link\_spec\_data.short\_hold\_mode***

Specifies whether the liveness protocol runs only if there has been no evidence that the remote system is still active since data was last transmitted (AP\_YES or AP\_NO).

Setting this parameter to AP\_YES allows links to stay active and idle without unnecessary data traffic, but means that link failures are not detected until the local station attempts to send data. In general this parameter should be set to AP\_NO.

### ***ipdlc\_link\_spec\_data.remote\_hostname***

Remote host name of the destination node for this link. This can be any of the following.

- An IPv4 dotted-decimal address (such as 193.1.11.100).
- An IPv6 colon-hexadecimal address (such as 2001:0db8:0000:0000:0000:0000:1428:57ab or 2001:db8::1428:57ab).
- A name (such as newbox.this.co.uk).
- An alias (such as newbox).

If you specify a name or alias, the AIX system must be able to resolve this to a fully qualified name (either using the local TCP/IP configuration or using a Domain Name server).

## Returned parameters: successful execution

If the verb executes successfully, CS/AIX returns the following parameters:

### ***primary\_rc***

AP\_OK

## Returned parameters: parameter check

If the verb does not execute because of a parameter error, CS/AIX returns the following parameters:

### ***primary\_rc***

AP\_PARAMETER\_CHECK

### ***secondary\_rc***

Possible values are:

#### **AP\_CANT\_MODIFY\_PORT\_NAME**

The *ls\_name* parameter matched the name of an existing LS, but the *port\_name* parameter did not match the existing definition. You cannot modify the port name when changing the definition of an existing LS.

**AP\_DEF\_LINK\_INVALID\_SECURITY**

The *tg\_chars.security* parameter was not set to a valid value.

**AP\_INVALID\_AUTO\_ACT\_SUPP**

The *auto\_act\_supp* parameter was not set to a valid value, or was set to AP\_YES when *cp\_cp\_sess\_support* was also set to AP\_YES.

**AP\_INVALID\_CP\_NAME**

The *adj\_cp\_name* parameter contained a character that was not valid, was not in the correct format, or was not specified when required.

**AP\_INVALID\_LIMITED\_RESOURCE**

The *limited\_resource* parameter was not set to a valid value.

**AP\_INVALID\_LINK\_NAME**

The *ls\_name* parameter contained a character that was not valid.

**AP\_INVALID\_LS\_ROLE**

The *ls\_role* parameter was not set to a valid value.

**AP\_INVALID\_NODE\_TYPE**

The *adj\_cp\_type* parameter was not set to a valid value.

**AP\_INVALID\_PORT\_NAME**

The *port\_name* parameter did not match the name of any defined port.

**AP\_INVALID\_PU\_NAME**

The *pu\_name* parameter did not match the name of any defined PU, or was set to a new value on an already-defined LS.

**AP\_INVALID\_DSPU\_NAME**

The *dspu\_name* parameter did not match the name of any defined PU, or was set to a new value on an already-defined LS.

**AP\_INVALID\_DSPU\_SERVICES**

The *dspu\_services* parameter was not set to a valid value, or was set when not expected.

**AP\_INVALID\_SOLICIT\_SSCP\_SESS**

The *solicit\_sscp\_sess* parameter was not set to a valid value.

**AP\_INVALID\_TARGET\_PACING\_CNT**

The *target\_pacing\_count* parameter was not set to a valid value.

**AP\_INVALID\_DLUS\_NAME**

The *dlus\_name* parameter contained a character that was not valid or was not in the correct format.

**AP\_INVALID\_BKUP\_DLUS\_NAME**

The *bkup\_dlus\_name* parameter contained a character that was not valid or was not in the correct format.

**AP\_INVALID\_TG\_NUMBER**

The TG number supplied was not in the valid range.

**AP\_MISSING\_CP\_NAME**

A TG number was defined, but no CP name was supplied.

**AP\_MISSING\_CP\_TYPE**

A TG number was defined, but no CP type was supplied.

**AP\_MISSING\_TG\_NUMBER**

The link was defined to be auto-activated, but no TG number was supplied.

**AP\_PARALLEL\_TGS\_NOT\_SUPPORTED**

This node cannot support more than one LS defined between it and the same adjacent node.

**AP\_INVALID\_DLUS\_RETRY\_LIMIT**

The value specified for *dlus\_retry\_limit* was not valid.

**AP\_INVALID\_DLUS\_RETRY\_TIMEOUT**

The value specified for *dlus\_retry\_timeout* was not valid.

## DEFINE\_LS

### **AP\_INVALID\_LS\_ROLE**

The value specified for the *ls\_role* parameter is not valid.

### **AP\_INVALID\_NODE\_TYPE\_FOR\_HPR**

The node type specified for the *adj\_cp\_type* parameter does not support HPR.

### **AP\_INVALID\_BTU\_SIZE**

The value specified for the *max\_send\_btu\_size* parameter was not valid.

### **AP\_INVALID\_MAX\_IFRM\_RCVD**

The value specified for the *max\_ifrm\_rcvd* parameter was not valid.

### **AP\_UNKNOWN\_IP\_HOST**

This value applies only for an Enterprise Extender (HPR/IP) link. The string specified for the *remote\_hostname* parameter could not be resolved to a valid IP address.

### **AP\_INVALID\_IP\_VERSION**

This value applies only for an Enterprise Extender (HPR/IP) link. The value specified in the *ip\_version* parameter did not match the value specified for the owning IP port.

### **AP\_INVALID\_BRANCH\_LINK\_TYPE**

The *branch\_link\_type* parameter was not set to a valid value.

### **AP\_INVALID\_BRNN\_SUPPORT**

The *adj\_brnn\_cp\_support* parameter was not set to a valid value.

### **AP\_BRNN\_SUPPORT\_MISSING**

The *adj\_brnn\_cp\_support* parameter was set to AP\_BRNN\_ALLOWED; this value is not valid because the adjacent node is a Network Node and *auto\_act\_supp* is set to AP\_YES.

### **AP\_INVALID\_UPLINK**

The *branch\_link\_type* parameter was set to AP\_UPLINK, but the definition of an existing LS between the local and adjacent nodes specifies that it is a downlink. The branch link type must be the same for all LSs between the same two nodes.

### **AP\_INVALID\_DOWNLINK**

The *branch\_link\_type* parameter was set to AP\_DOWNLINK, but the definition of an existing LS between the local and adjacent nodes specifies that it is an uplink. The branch link type must be the same for all LSs between the same two nodes.

### **AP\_INVALID\_LINK\_SPEC\_FORMAT**

A reserved parameter was set to a nonzero value.

Appendix B, "Common return codes," on page 661 lists further secondary return codes associated with AP\_PARAMETER\_CHECK, which are common to all NOF verbs.

## Returned parameters: state check

If the verb does not execute because of a state error, CS/AIX returns the following parameters.

### ***primary\_rc***

AP\_STATE\_CHECK

### ***secondary\_rc***

Possible values are:

#### **AP\_DUPLICATE\_CP\_NAME**

A link to the CP name specified in the *adj\_cp\_name* parameter has already been defined.

#### **AP\_DUPLICATE\_DEST\_ADDR**

A link to the destination address specified in the *address* parameter has already been defined.

For LLC2 link types: A link to the destination address specified by the combination of the *mac\_address* and *lsap\_address* parameters has already been defined.

#### **AP\_DUPLICATE\_ADJ\_NODE\_ID**

The *adj\_node\_id* (node ID of adjacent node) has already been defined in another link station.

#### **AP\_INVALID\_LINK\_NAME**

The link station value specified in the *ls\_name* parameter was not valid.



**AP\_INVALID\_NUM\_LS\_SPECIFIED**

The number of link stations specified was not valid.

**AP\_LOCAL\_CP\_NAME**

The name specified for the *adj\_cp\_name* parameter is identical to the local CP name.

**AP\_LS\_ACTIVE**

The link station specified in the *ls\_name* parameter is currently active.

**AP\_PU\_ALREADY\_DEFINED**

The PU specified in the *pu\_name* parameter has already been defined.

**AP\_DSPU\_ALREADY\_DEFINED**

The downstream PU specified in the *dspu\_name* parameter has already been defined.

**AP\_DSPU\_SERVICES\_NOT\_SUPPORTED**

AP\_PU\_CONCENTRATION or AP\_DLUR has been specified on the *dspu\_services* parameter, but the node does not support it.

**AP\_DUPLICATE\_TG\_NUMBER**

The TG number specified in the *tg\_number* parameter has already been defined.

**AP\_TG\_NUMBER\_IN\_USE**

The TG number specified for the *tg\_number* parameter is already being used by another LS.

Appendix B, “Common return codes,” on page 661 lists further secondary return codes associated with AP\_STATE\_CHECK, which are common to all NOF verbs.

**Returned parameters: other conditions**

Appendix B, “Common return codes,” on page 661 lists further combinations of primary and secondary return codes that are common to all NOF verbs.

**Bit ordering in MAC addresses**

Ethernet LANs use a different representation of MAC addresses from that used by Token Ring; the order of the bits in each byte of the address on Ethernet is the reverse of the order on Token Ring. Normally, the local and remote nodes are on the same LAN, or on LANs of the same type connected by a bridge; in this case, they will both use the same representation of the MAC address, and no conversion is required.

If the two nodes are on LANs of different types (one Ethernet, the other Token Ring) connected by a bridge, you will normally need to reverse the bit order of each byte of the address when specifying a remote MAC address. To do this, take the following steps:

1. List the MAC address as six bytes, each byte represented by two hexadecimal digits.
2. List the MAC address as six bytes, each byte represented by two hexadecimal digits.
3. Convert each digit as shown below:

0 -> 0	8 -> 1
1 -> 8	9 -> 9
2 -> 4	A -> 5
3 -> C	B -> D
4 -> 2	C -> 3
5 -> A	D -> B
6 -> 6	E -> 7
7 -> E	F -> F

Example of Bit Ordering in a MAC Address

Original address	1A	2B	3C	4D	5E	6F
------------------	----	----	----	----	----	----

Swap digits	A1	B2	C3	D4	E5	F6
Convert digits (the bit-reversed form of the original address)	58	D4	3C	B2	7A	F6

## Modem control characters

For SDLC, if you need to include one or more non-printable control characters in the *hmod\_data* parameter, you can do this by specifying the hexadecimal value of the control character, as listed in [Table 2 on page 126](#).

*Table 2. Escape Sequences for Modem Control Characters*

Escape Sequence	Decimal Value	Hexadecimal Value
NUL	0	0x00
SOH	1	0x01
STX	2	0x02
ETX	3	0x03
EOT	4	0x04
ENQ	5	0x05
ACK	6	0x06
BEL	7	0x07
BS	8	0x08
HT	9	0x09
LF	10	0x0A
VT	11	0x0B
FF	12	0x0C
CR	13	0x0D
SO	14	0x0E
SI	15	0x0F
DLE	16	0x10
DC1	17	0x11
DC2	18	0x12
DC3	19	0x13
DC4	20	0x14
NAK	21	0x15
SYN	22	0x16
ETB	23	0x17
CAN	24	0x18
EM	25	0x19
SUB	26	0x1A
ESC	27	0x1B
FS	28	0x1C

Table 2. Escape Sequences for Modem Control Characters (continued)

Escape Sequence	Decimal Value	Hexadecimal Value
GS	29	0x1D
RS	30	0x1E
US	31	0x1F
SP	32	0x20
DEL	127	0x7F

## DEFINE\_LS\_ROUTING

The DEFINE\_LS\_ROUTING verb defines the location of a partner LU using a link station.

**Note:** You cannot use DEFINE\_LS\_ROUTING with an Enterprise Extender (HPR/IP) link station. This is because all traffic on this link type must flow over an RTP connection, which is not fixed to a particular link station and can switch to a different path.

### VCB structure

```
typedef struct define_ls_routing
{
    AP_UINT16      opcode;           /* verb operation code          */
    unsigned char  reserv2;         /* reserved                     */
    unsigned char  format;         /* reserved                     */
    AP_UINT16      primary_rc;     /* primary return code          */
    AP_UINT32      secondary_rc;   /* secondary return code        */
    unsigned char  lu_name[8];     /* LU Name                      */
    unsigned char  lu_alias[8];   /* reserved                     */
    unsigned char  fq_partner_lu[17]; /* partner lu name             */
    unsigned char  wildcard_fqplu; /* wildcard partner LU flag    */
    unsigned char  ls_name[8];    /* link to use                  */
    unsigned char  reserv3[2];    /* reserved                     */
} DEFINE_LS_ROUTING;
```

### Supplied parameters

The application supplies the following parameters:

#### **opcode**

AP\_DEFINE\_LS\_ROUTING

#### **lu\_name**

Name of the local LU that will communicate with the partner LU (specified by the *fq\_partner\_lu* parameter) over the link specified by the *ls\_name* parameter. This is an 8-byte type-A character string.

#### **fq\_partner\_lu**

Fully qualified name of the partner LU with which the local LU (specified by the *lu\_name* parameter) will communicate over the link specified by the *ls\_name* parameter. Specify 3-17 characters that consists of a 1-8 character network name, followed by a period, followed by a 1-8 character partner LU name.

You can specify a partial or full wildcard partner LU name by specifying only part of the name and setting the *wildcard\_fqplu* parameter to AP\_YES. For example:

- APPN.NEW matches APPN.NEW1, APPN.NEWLU, and so on
- APPN. matches any LU with a network name of APPN, regardless of its LU name
- APPN matches any LU with a network name beginning with APPN: APPN.NEW1, APPNNEW.LUTWO, and so on.

To specify a full wildcard entry, so that all partner LUs will be accessed using the same link, set *wildcard\_fqplu* to AP\_YES and set *fq\_partner\_lu* to a null string.

## DEFINE\_LS\_ROUTING

### ***wildcard\_fqplu***

Wildcard partner LU flag indicating whether the *fq\_partner\_lu* parameter contains a full or partial wildcard. Possible values are:

#### **AP\_YES**

The *fq\_partner\_lu* parameter contains a wildcard entry.

#### **AP\_NO**

The *fq\_partner\_lu* parameter does not contain a wildcard entry.

### ***ls\_name***

Name of the link station to use for communication between the local LU (specified by the *lu\_name* parameter) and the partner LU (specified in the *fq\_partner\_lu* parameter). Specify 1-8 locally displayable characters.

## Returned parameters: successful execution

If the verb executes successfully, CS/AIX returns the following parameter:

### ***primary\_rc***

AP\_OK

## Returned parameters: parameter check

If the verb does not execute because of a parameter error, CS/AIX returns the following parameters:

### ***primary\_rc***

AP\_PARAMETER\_CHECK

### ***secondary\_rc***

Possible values are:

#### **AP\_INVALID\_LU\_NAME**

The *lu\_name* parameter contained a character that was not valid.

#### **AP\_INVALID\_PLU\_NAME**

The *fq\_partner\_lu* parameter contained a character that was not valid or the name was not fully qualified.

#### **AP\_INVALID\_WILDCARD\_NAME**

The *wildcard\_fqplu* parameter was specified but the *fq\_partner\_lu* parameter was not a valid wildcard name.

Appendix B, “[Common return codes](#),” on page 661 lists further secondary return codes associated with AP\_PARAMETER\_CHECK, which are common to all NOF verbs.

## Returned parameters: state check

If the verb does not execute because of a state error, CS/AIX returns the following parameters.

### ***primary\_rc***

AP\_STATE\_CHECK

### ***secondary\_rc***

Possible values are:

#### **AP\_INVALID\_LU\_NAME**

The local LU identified by the *lu\_name* parameter does not exist.

Appendix B, “[Common return codes](#),” on page 661 lists further secondary return codes associated with AP\_STATE\_CHECK, which are common to all NOF verbs.

## Returned parameters: other conditions

Appendix B, “[Common return codes](#),” on page 661 lists further combinations of primary and secondary return codes that are common to all NOF verbs.

## DEFINE\_LU62\_TIMEOUT

The DEFINE\_LU62\_TIMEOUT verb defines a timeout period for unused LU 6.2 sessions. Each timeout is for a specified resource type and resource name. If a DEFINE\_\* verb is issued for a resource type and name pair already defined, the command overwrites the previous definitions. New timeout periods are only used for sessions activated after the definition is changed.

If more than one relevant timeout period is defined for a session, the shortest period applies.

### VCB structure

```
typedef struct define_lu62_timeout
{
    AP_UINT16      opcode;                /* verb operation code */
    unsigned char  reserv2;              /* reserved */
    unsigned char  format;              /* reserved */
    AP_UINT16      primary_rc;          /* primary return code */
    AP_UINT32      secondary_rc;       /* secondary return code */
    unsigned char  resource_type;       /* resource type */
    unsigned char  resource_name[17];   /* resource name */
    AP_UINT16      timeout;            /* timeout */
} DEFINE_LU62_TIMEOUT;
```

### Supplied parameters

The application supplies the following parameters:

#### **opcode**

AP\_DEFINE\_LU62\_TIMEOUT

#### **resource\_type**

Specifies the type of timeout to be defined. Possible values are:

##### **AP\_GLOBAL\_TIMEOUT**

Timeout applies to all LU 6.2 sessions for the local node. The *resource\_name* parameter should be set to all zeros.

##### **AP\_LOCAL\_LU\_TIMEOUT**

Timeout applies to all LU 6.2 sessions for the local LU specified in the *resource\_name* parameter.

##### **AP\_PARTNER\_LU\_TIMEOUT**

Timeout applies to all LU 6.2 sessions to the partner LU specified in the *resource\_name* parameter.

##### **AP\_MODE\_TIMEOUT**

Timeout applies to all LU 6.2 sessions on the mode specified in the *resource\_name* parameter.

#### **resource\_name**

Name of the resource being queried. This value can be one of the following:

- If *resource\_type* is set to AP\_GLOBAL\_TIMEOUT, do not specify this parameter.
- If *resource\_type* is set to AP\_LOCAL\_LU\_TIMEOUT, specify 1-8 locally displayable type-A characters as a local LU name.
- If *resource\_type* is set to AP\_PARTNER\_LU\_TIMEOUT, specify the fully qualified name of the partner LU as follows: 17 locally displayable type-A characters consisting of a 1-8 character network name, followed by a period, followed by a 1-8 character partner LU name.
- If *resource\_type* is set to AP\_MODE\_TIMEOUT, specify 1-8 locally displayable type-A characters as a mode name.

#### **timeout**

Timeout period in seconds. A value of 0 (zero) indicates that the session immediately becomes free.

### Returned parameters: successful execution

If the verb executes successfully, CS/AIX returns the following parameters:

## DEFINE\_LU\_0\_TO\_3

### *primary\_rc*

AP\_OK

## Returned parameters: parameter check

If the verb does not execute because of a parameter error, CS/AIX returns the following parameters:

### *primary\_rc*

AP\_PARAMETER\_CHECK

### *secondary\_rc*

Possible values are:

#### **AP\_INVALID\_RESOURCE\_TYPE**

The type of timeout defined was not valid.

#### **AP\_INVALID\_LU\_NAME**

The *resource\_type* parameter specified an LU name that was not valid.

#### **AP\_INVALID\_PARTNER\_LU**

The *resource\_type* parameter specified a partner LU name that was not valid.

#### **AP\_INVALID\_MODE\_NAME**

The *resource\_type* parameter specified a mode name that was not valid.

Appendix B, “Common return codes,” on page 661 lists further secondary return codes associated with AP\_PARAMETER\_CHECK, which are common to all NOF verbs.

## Returned parameters: other conditions

Appendix B, “Common return codes,” on page 661 lists further combinations of primary and secondary return codes that are common to all NOF verbs.

## DEFINE\_LU\_0\_TO\_3

The DEFINE\_LU\_0\_TO\_3 verb defines an LU for use with 3270 emulation or LUA (an LU of type 0, 1, 2, or 3), and optionally assigns the LU to an LU pool.

If this verb is used to modify an existing LU, only the *description*, *priority*, and *lu\_model* parameters can be changed; all other parameters must be set to their existing values.

## VCB structure

```
typedef struct define_lu_0_to_3
{
    AP_UINT16          opcode;          /* verb operation code      */
    unsigned char      reserv2;         /* reserved                  */
    unsigned char      format;         /* reserved                  */
    AP_UINT16          primary_rc;     /* primary return code      */
    AP_UINT32          secondary_rc;   /* secondary return code    */
    unsigned char      lu_name[8];     /* LU name                   */
    LU_0_TO_3_DEF_DATA def_data;      /* defined data              */
} DEFINE_LU_0_TO_3;
```

```
typedef struct lu_0_to_3_def_data
{
    unsigned char      description[32]; /* resource description      */
    unsigned char      reserv1[16];    /* reserved                  */
    unsigned char      nau_address;    /* LU NAU address           */
    unsigned char      pool_name[8];   /* LU Pool name             */
    unsigned char      pu_name[8];    /* PU name                   */
    unsigned char      priority;       /* LU priority               */
    unsigned char      lu_model;       /* LU model (type)          */
    unsigned char      sscp_id[6];     /* SSCP ID                   */
    AP_UINT16          timeout;        /* Timeout                   */
    unsigned char      app_spec_def_data[16]; /* reserved                  */
    unsigned char      model_name[7];  /* reserved                  */
    unsigned char      term_method;    /* session termination type */
    unsigned char      disconnect_on_unbind; /* disconnect on UNBIND flag */
}
```

```

    unsigned char    reserv3[15];           /* reserved          */
} LU_0_TO_3_DEF_DATA;

```

## Supplied parameters

The application supplies the following parameters:

### ***opcode***

AP\_DEFINE\_LU\_0\_TO\_3

### ***lu\_name***

Name of the local LU. This is an 8-byte type-A EBCDIC string (starting with a letter), padded on the right with EBCDIC spaces.

### ***def\_data.description***

A null-terminated text string (0-31 characters followed by a null character) describing the LU. This string is for information only; it is stored in the node's configuration file and returned on the QUERY\_LU\_0\_TO\_3 verb, but CS/AIX does not make any other use of it.

### ***def\_data.nau\_address***

Network accessible unit address of the LU. This is a number in the range 1-255.

### ***def\_data.pool\_name***

Name of pool to which this LU belongs. This is a type-A EBCDIC string, padded on the right with EBCDIC spaces if the name is shorter than 8 bytes. If a pool with the specified name is not already defined, CS/AIX adds a new pool with this name and assigns the LU to it.

If the LU does not belong to a pool, set this field to 8 binary zeros.

### ***def\_data.pu\_name***

Name of the PU (as specified on the DEFINE\_LS verb) which this LU will use. This is an 8-byte type-A EBCDIC string (starting with a letter), padded on the right with EBCDIC spaces if the name is shorter than 8 bytes.

### ***def\_data.priority***

LU priority when sending to the host. Possible values are:

AP\_NETWORK

AP\_HIGH

AP\_MEDIUM

AP\_LOW

### ***def\_data.lu\_model***

Type of the LU. Possible values are:

AP\_3270\_DISPLAY\_MODEL\_2

AP\_3270\_DISPLAY\_MODEL\_3

AP\_3270\_DISPLAY\_MODEL\_4

AP\_3270\_DISPLAY\_MODEL\_5

AP\_PRINTER

AP\_SCS\_PRINTER

AP\_RJE\_WKSTN

AP\_UNKNOWN (LU type will be determined when the session to the host is established)

If you are not using the LU for 3270 emulation, it is not necessary to specify an explicit LU type; set this parameter to AP\_UNKNOWN.

Depending on the value you specify, CS/AIX sends one of the following strings to the host in the DDDL U NMVT, to match the values used in the standard VTAM tables:

- 3270002 for AP\_3270\_DISPLAY\_MODEL\_2

## DEFINE\_LU\_0\_TO\_3

- 3270003 for AP\_3270\_DISPLAY\_MODEL\_3
- 3270004 for AP\_3270\_DISPLAY\_MODEL\_4
- 3270005 for AP\_3270\_DISPLAY\_MODEL\_5
- 3270DSC for AP\_PRINTER
- 3270SCS for AP\_SCS\_PRINTER
- 3270000 for AP\_RJE\_WKSTN
- 327000*n* for AP\_UNKNOWN with a TN3270 client, where *n* is the model number (2-5) provided by the client
- 327000@ for AP\_UNKNOWN with an LUA client

If the host system supports Dynamic Definition of Dependent LUs (DDDLUs), CS/AIX will define the LU dynamically on the host when the communications link to the host is established. For a TN3270 client, set this parameter to AP\_UNKNOWN. CS/AIX then determines the LU model using a standard mapping from the terminal type (device type) specified by the client; if you need to change this mapping, you can do this using the `tn3270dev.dat` file as described in *IBM Communications Server for Data Center Deployment on AIX Administration Guide*.

If the host does not support DDDLUs, the LU must be included in the host configuration.

### ***def\_data.sscp\_id***

Specifies the ID of the SSCP permitted to activate this LU. Set this parameter to 0 (zero) if the LU can be activated by any SSCP. If the LU is to be activated only by a specific SSCP, set the first four bytes of this parameter to 0x05000000 and the last two bytes to the SSCP ID that identifies the SSCP that is permitted to activate the LU.

### ***def\_data.timeout***

Timeout for the LU specified in seconds. If the timeout is set to a nonzero value and the user of the LU supports session inactivity timeouts, then the LU is deactivated after the PLU-SLU session is left inactive for the specified period and one of the following conditions exist:

- The session passes over a limited resource link.
- Another application requests to use the LU before the session is used again.

If the timeout is set to 0 (zero), the LU is not deactivated.

Support for session inactivity timeouts depends on the application that is using the LU (such as a 3270 emulation program). If the LU is being used by SNA gateway, session inactivity timeouts are supported only if *allow\_timeout* is specified on the DEFINE\_DOWNSTREAM\_LU verb.

### ***def\_data.term\_method***

This parameter specifies how CS/AIX should attempt to end a PLU-SLU session to a host from this LU. Possible values are:

#### **AP\_USE\_NODE\_DEFAULT**

Use the node's default termination method, specified by the *send\_term\_self* parameter on DEFINE\_NODE.

#### **AP\_SEND\_UNBIND**

End the session by sending an UNBIND.

#### **AP\_SEND\_TERM\_SELF**

End the session by sending a TERM\_SELF.

### ***def\_data.disconnect\_on\_unbind***

This parameter applies only when this LU is being used by a TN3270 client. It specifies whether to end the session when the host sends an UNBIND instead of displaying the VTAM MSG10 or returning to a host session manager. Possible values are:

#### **AP\_YES**

End the session if the host sends an UNBIND that is not type 2 (BIND forthcoming).

#### **AP\_NO**

Do not end the session if the host sends an UNBIND.



## Returned parameters: successful execution

If the verb executes successfully, CS/AIX returns the following parameters:

**primary\_rc**  
AP\_OK

## Returned parameters: parameter check

If the verb does not execute because of a parameter error, CS/AIX returns the following parameters:

**primary\_rc**  
AP\_PARAMETER\_CHECK

**secondary\_rc**  
Possible values are:

**AP\_INVALID\_LU\_NAME**  
The *lu\_name* parameter contained a character that was not valid.

**AP\_INVALID\_POOL\_NAME**  
The *pool\_name* parameter contained a character that was not valid.

**AP\_INVALID\_NAU\_ADDRESS**  
The *nau\_address* parameter was not in the permitted range.

**AP\_INVALID\_PRIORITY**  
The *priority* parameter was not set to a valid value.

**AP\_INVALID\_TERM\_METHOD**  
The *term\_method* parameter was not set to a valid value.

Appendix B, “Common return codes,” on page 661 lists further secondary return codes associated with AP\_PARAMETER\_CHECK, which are common to all NOF verbs.

## Returned parameters: state check

If the verb does not execute because of a state error, CS/AIX returns the following parameters.

**primary\_rc**  
AP\_STATE\_CHECK

**secondary\_rc**  
Possible values are:

**AP\_INVALID\_PU\_NAME**  
The *pu\_name* parameter was not valid.

**AP\_PU\_NOT\_DEFINED**  
The *pu\_name* parameter did not match any defined PU name.

**AP\_INVALID\_PU\_TYPE**  
The PU specified by the *pu\_name* parameter is not a host PU.

**AP\_LU\_NAME\_POOL\_NAME\_CLASH**  
The LU name clashes with the name of an LU pool.

**AP\_LU\_ALREADY\_DEFINED**  
An LU with the specified name has already been defined.

**AP\_LU\_NAU\_ADDR\_ALREADY\_DEF**  
An LU with the specified NAU address has already been defined.

Appendix B, “Common return codes,” on page 661 lists further secondary return codes associated with AP\_STATE\_CHECK, which are common to all NOF verbs.

## Returned parameters: other conditions

Appendix B, “Common return codes,” on page 661 lists further combinations of primary and secondary return codes that are common to all NOF verbs.

## DEFINE\_LU\_0\_TO\_3\_RANGE

The DEFINE\_LU\_0\_TO\_3\_RANGE verb defines a range of LUs for use with 3270 emulation or LUA (LUs of type 0, 1, 2, or 3), and optionally assigns the LUs to an LU pool. This verb cannot be used to modify existing LUs.

The supplied parameters to this verb include a base name for the new LUs and the range of NAU addresses. The new LU names are generated by combining the base name with the NAU addresses. For example, a base name of LUNME combined with a NAU range of 11 to 14 would define the LUs LUNME011, LUNME012, LUNME013 and LUNME014.

## VCB structure

```
typedef struct define_lu_0_to_3_range
{
    AP_UINT16      opcode;                /* verb operation code */
    unsigned char  reserv2;               /* reserved */
    unsigned char  format;                /* reserved */
    AP_UINT16      primary_rc;            /* primary return code */
    AP_UINT32      secondary_rc;          /* secondary return code */
    unsigned char  base_name[6];          /* Base name */
    unsigned char  description[32];        /* resource description */
    unsigned char  reserv1[16];           /* reserved */
    unsigned char  min_nau;                /* Minimum NAU address */
    unsigned char  max_nau;                /* Maximum NAU address */
    unsigned char  pool_name[8];          /* LU Pool name */
    unsigned char  pu_name[8];            /* PU name */
    unsigned char  priority;               /* LU priority */
    unsigned char  lu_model;               /* LU model (type) */
    unsigned char  sscp_id[6];             /* SSCP ID */
    AP_UINT16      timeout;                /* Timeout */
    unsigned char  app_spec_def_data[16]; /* reserved */
    unsigned char  reserv3[7];             /* reserved */
    unsigned char  name_attributes;        /* Extension type */
    unsigned char  base_number;            /* First extension number */
    unsigned char  term_method;            /* session termination type */
    unsigned char  disconnect_on_unbind;   /* disconnect on UNBIND flag */
    unsigned char  reserv4[13];           /* reserved */
} DEFINE_LU_0_TO_3_RANGE;
```

## Supplied parameters

The application supplies the following parameters:

### **opcode**

AP\_DEFINE\_LU\_0\_TO\_3\_RANGE

### **base\_name**

Base name for the names of the new LUs. This is a 6-byte type-A EBCDIC string (starting with a letter), padded on the right with EBCDIC spaces if the base name is less than 6 characters.

- If the *name\_attributes* parameter is set to AP\_USE\_HEX\_IN\_NAME, this name may be up to 6 characters long. CS/AIX generates the LU name for each LU by appending a 2-digit hexadecimal number to this name (starting from a base number specified by the *base\_number* parameter).
- Otherwise, this name may be up to 5 characters long. CS/AIX generates the LU name for each LU by appending a 3-digit decimal number to this name (taken from the NAU address or from a defined base number, as specified by the *name\_attributes* parameter).

### **description**

A null-terminated text string (0-31 characters followed by a null character) describing the LUs; the same string is used for each LU in the range. This string is for information only; it is stored in the

node's configuration file and returned on the QUERY\_LU\_0\_TO\_3 verb, but CS/AIX does not make any other use of it.

***min\_nau***

NAU address of the first LU, in the range 1-255.

***max\_nau***

NAU address of the last LU, in the range 1-255.

***pool\_name***

Name of pool to which these LUs belong. This is an 8-byte type-A EBCDIC string, padded on the right with EBCDIC spaces if the name is shorter than 8 bytes. If a pool with the specified name is not already defined, CS/AIX adds a new pool with this name and assigns the LUs to it.

If the LUs do not belong to a pool, set this field to 8 binary zeros.

***pu\_name***

Name of the PU (as specified on the DEFINE\_LS verb) which these LUs will use. This is an 8-byte type-A EBCDIC string (starting with a letter), padded on the right with EBCDIC spaces.

***priority***

LU priority when sending to the host. Possible values are:

AP\_NETWORK

AP\_HIGH

AP\_MEDIUM

AP\_LOW

***lu\_model***

Type of the LUs. Possible values are:

AP\_3270\_DISPLAY\_MODEL\_2

AP\_3270\_DISPLAY\_MODEL\_3

AP\_3270\_DISPLAY\_MODEL\_4

AP\_3270\_DISPLAY\_MODEL\_5

AP\_PRINTER

AP\_SSCP\_PRINTER

AP\_RJE\_WKSTN

AP\_UNKNOWN (LU type will be determined when the session to the host is established)

If you are not using the LUs for 3270 emulation, it is not necessary to specify an explicit LU type; set this parameter to AP\_UNKNOWN.

Depending on the value you specify, CS/AIX sends one of the following strings to the host in the DDDLU NMVT, to match the values used in the standard VTAM tables:

- 3270002 for AP\_3270\_DISPLAY\_MODEL\_2
- 3270003 for AP\_3270\_DISPLAY\_MODEL\_3
- 3270004 for AP\_3270\_DISPLAY\_MODEL\_4
- 3270005 for AP\_3270\_DISPLAY\_MODEL\_5
- 3270DSC for AP\_PRINTER
- 3270SCS for AP\_SCS\_PRINTER
- 3270000 for AP\_RJE\_WKSTN
- 327000*n* for AP\_UNKNOWN with a TN3270 client, where *n* is the model number (2-5) provided by the client
- 327000@ for AP\_UNKNOWN with an LUA client

## DEFINE\_LU\_0\_TO\_3\_RANGE

If the host system supports Dynamic Definition of Dependent LUs (DDDLUs), CS/AIX will define the LU dynamically on the host when the communications link to the host is established. For a TN3270 client, set this parameter to AP\_UNKNOWN. CS/AIX then determines the LU model using a standard mapping from the terminal type (device type) specified by the client; if you need to change this mapping, you can do this using the `tn3270dev.dat` file as described in *IBM Communications Server for Data Center Deployment on AIX Administration Guide*.

If the host does not support DDDLUs, or if this parameter is set to AP\_UNKNOWN, the LUs must be included in the host configuration.

### ***sscp\_id***

Specifies the ID of the SSCP permitted to activate this LU. Specify a value in the range 0-65,535. If this parameter is set to 0 (zero), the LU can be activated by any SSCP.

### ***timeout***

Timeout for the LU specified in seconds. If the timeout is set to a nonzero value and the user of the LU supports session inactivity timeouts, then the LU is deactivated after the PLU-SLU session is left inactive for the specified period and one of the following conditions exist:

- The session passes over a limited resource link.
- Another application requests to use the LU before the session is used again.

If the timeout is set to 0 (zero), the LU is not deactivated.

Support for session inactivity timeouts depends on the application that is using the LU (such as a 3270 emulation program). If the LU is being used by SNA gateway, session inactivity timeouts are supported only if *allow\_timeout* is specified on the DEFINE\_DOWNSTREAM\_LU verb.

### ***name\_attributes***

Attributes of the LUs to be defined. Possible values are:

#### **AP\_NONE**

LU names have numbers corresponding to the NAU numbers. The numbers are specified in decimal and the *base\_name* parameter can only be up to 5 characters.

#### **AP\_USE\_BASE\_NUMBER**

Start naming the LUs in the range from the value specified in the *base\_number* parameter.

#### **AP\_USE\_HEX\_IN\_NAME**

Add the extension to the LU name in hex rather than decimal. The *base\_name* parameter can contain up to 6 characters if this value is specified.

#### **AP\_USE\_TWO\_DECIMAL\_DIGITS**

Add the extension to the LU name using two decimal digits (without this option 3 digits are used). If this attribute is used then at most 99 LUs can be defined in this range. The *base\_name* parameter can contain up to 6 characters if this value is specified.

### ***base\_number***

If AP\_USE\_BASE\_NUMBER is specified in the *name\_attributes* parameter, specify a number from which to start naming the LUs in the range. This value will be used instead of the value of the *min\_nau* parameter.

### ***term\_method***

This parameter specifies how CS/AIX should attempt to end a PLU-SLU session to a host from one of these LUs. Possible values are:

#### **AP\_USE\_NODE\_DEFAULT**

Use the node's default termination method, specified by the *send\_term\_self* parameter on DEFINE\_NODE.

#### **AP\_SEND\_UNBIND**

End the session by sending an UNBIND.

#### **AP\_SEND\_TERM\_SELF**

End the session by sending a TERM\_SELF.

***disconnect\_on\_unbind***

This parameter applies only when an LU in this range is being used by a TN3270 client. It specifies whether to end the session when the host sends an UNBIND instead of displaying the VTAM MSG10 or returning to a host session manager. Possible values are:

**AP\_YES**

End the session if the host sends an UNBIND that is not type 2 (BIND forthcoming).

**AP\_NO**

Do not end the session if the host sends an UNBIND.

**Returned parameters: successful execution**

If the verb executes successfully, CS/AIX returns the following parameters:

***primary\_rc***

AP\_OK

**Returned parameters: parameter check**

If the verb does not execute because of a parameter error, CS/AIX returns the following parameters:

***primary\_rc***

AP\_PARAMETER\_CHECK

***secondary\_rc***

Possible values are:

**AP\_INVALID\_LU\_NAME**

The *base\_name* parameter contained a character that was not valid.

**AP\_INVALID\_POOL\_NAME**

The *pool\_name* parameter contained a character that was not valid.

**AP\_INVALID\_NAU\_ADDRESS**

One or more of the LU addresses were not in the permitted range.

**AP\_INVALID\_PRIORITY**

The *priority* parameter was not set to a valid value.

**AP\_INVALID\_TERM\_METHOD**

The *term\_method* parameter was not set to a valid value.

Appendix B, "Common return codes," on page 661 lists further secondary return codes associated with AP\_PARAMETER\_CHECK, which are common to all NOF verbs.

**Returned parameters: state check**

If the verb does not execute because of a state error, CS/AIX returns the following parameters.

***primary\_rc***

AP\_STATE\_CHECK

***secondary\_rc***

Possible values are:

**AP\_INVALID\_PU\_NAME**

The *pu\_name* parameter was not valid.

**AP\_PU\_NOT\_DEFINED**

The *pu\_name* parameter did not match any defined PU name.

**AP\_INVALID\_PU\_TYPE**

The PU specified by the *pu\_name* parameter is not a host PU.

**AP\_LU\_NAME\_POOL\_NAME\_CLASH**

One of the LU names in the range clashes with the name of an LU pool.

## DEFINE\_LU\_LU\_PASSWORD

### AP\_LU\_ALREADY\_DEFINED

An LU has already been defined with the name of one of the LUs in the range.

### AP\_LU\_NAU\_ADDR\_ALREADY\_DEFD

An LU has already been defined with the address of one of the LUs in the range.

Appendix B, “Common return codes,” on page 661 lists further secondary return codes associated with AP\_STATE\_CHECK, which are common to all NOF verbs.

## Returned parameters: other conditions

Appendix B, “Common return codes,” on page 661 lists further combinations of primary and secondary return codes that are common to all NOF verbs.

## DEFINE\_LU\_LU\_PASSWORD

DEFINE\_LU\_LU\_PASSWORD provides a password which is used for session-level security verification between a local LU and a partner LU.

## VCB structure

```
typedef struct define_lu_lu_password
{
    AP_UINT16      opcode;                /* verb operation code      */
    unsigned char  reserv2;               /* reserved                  */
    unsigned char  format;                /* reserved                  */
    AP_UINT16      primary_rc;            /* primary return code      */
    AP_UINT32      secondary_rc;          /* secondary return code    */
    unsigned char  lu_name[8];            /* local LU name            */
    unsigned char  lu_alias[8];           /* local LU alias           */
    unsigned char  fqplu_name[17];        /* fully qualified partner  */
    unsigned char  verification_protocol; /* LU name                   */
    unsigned char  description[32];        /* verification protocol    */
    unsigned char  reserv1[16];           /* resource description     */
    unsigned char  reserv3[8];            /* reserved                  */
    unsigned char  password[8];           /* reserved                  */
} DEFINE_LU_LU_PASSWORD;
```

## Supplied parameters

The application supplies the following parameters:

### ***opcode***

AP\_DEFINE\_LU\_LU\_PASSWORD

### ***lu\_name***

LU name of the local LU, as defined to CS/AIX. This is an 8-byte type-A EBCDIC string, padded on the right with spaces if the name is shorter than 8 bytes. To indicate that the LU is defined by its LU alias instead of its LU name, set this parameter to 8 binary zeros.

### ***lu\_alias***

LU alias of the local LU, as defined to CS/AIX. This is an 8-byte ASCII string, using any locally displayable characters, padded on the right with spaces if the name is shorter than 8 bytes. It is used only if *lu\_name* is set to zeros.

To indicate the LU associated with the CP (the default LU), set both *lu\_name* and *lu\_alias* to 8 binary zeros.

### ***fqplu\_name***

Fully qualified LU name for the partner LU, as defined to CS/AIX. The name is a 17-byte EBCDIC string, right-padded with EBCDIC spaces. It consists of a network ID of up to 8 A-string characters, an EBCDIC dot (period) character, and a network name of up to 8 A-string characters.

### ***verification\_protocol***

Requested LU-LU verification protocol to use. Possible values are:

**AP\_BASIC**

Use basic LU-LU verification protocols.

**AP\_ENHANCED**

Use enhanced LU-LU verification protocols.

**AP\_EITHER**

Basic or enhanced verification is accepted.

**description**

A null-terminated text string (0-31 characters followed by a null character) describing the password. This string is for information only; it is stored in the node's configuration file and returned on the QUERY\_LU\_LU\_PASSWORD verb, but CS/AIX does not make any other use of it.

**password**

Password. This is an 8-byte hexadecimal string, which must not be set to all blanks or all zeros. It must match the equivalent parameter configured for the partner LU on the remote system (except that the least significant bit of each byte is not used in session-level security verification and does not need to match).

Whatever value the application supplies for this parameter is immediately replaced by the encrypted version of the password. Therefore, the value supplied for the *password* parameter is never written out.

**Returned parameters: successful execution**

If the verb executes successfully, CS/AIX returns the following parameters:

**primary\_rc**

AP\_OK

**Returned parameters: parameter check**

If the verb does not execute because of a parameter error, CS/AIX returns the following parameters:

**primary\_rc**

AP\_PARAMETER\_CHECK

**secondary\_rc**

Possible values are:

**AP\_INVALID\_LU\_ALIAS**

The *lu\_alias* parameter did not match any defined LU alias.

**AP\_INVALID\_LU\_NAME**

The *lu\_name* parameter did not match any defined local LU name.

**AP\_INVALID\_PLU\_NAME**

The *fqplu\_name* parameter did not match any defined partner LU name.

**AP\_INVALID\_PASSWORD**

The *password* parameter is blank or null.

Appendix B, “Common return codes,” on page 661 lists further secondary return codes associated with AP\_PARAMETER\_CHECK, which are common to all NOF verbs.

**Returned parameters: other conditions**

Appendix B, “Common return codes,” on page 661 lists further combinations of primary and secondary return codes that are common to all NOF verbs.

## DEFINE\_LU\_POOL

This verb is used to define an LU pool and assign LUs to it, or to assign additional LUs to an existing pool. The LUs must be defined before adding them to the pool. You can also define a pool by specifying the pool name when defining an LU; for more information, see [“DEFINE\\_LU\\_0\\_TO\\_3” on page 130](#).

This verb cannot be used to modify an existing pool by removing LUs from it; the DELETE\_LU\_POOL verb is used to do this.

### VCB structure

```
typedef struct define_lu_pool
{
    AP_UINT16      opcode;           /* verb operation code          */
    unsigned char  reserv2;         /* reserved                      */
    unsigned char  format;         /* reserved                      */
    AP_UINT16      primary_rc;     /* primary return code          */
    AP_UINT32      secondary_rc;   /* secondary return code        */
    unsigned char  pool_name[8];   /* LU pool name                 */
    unsigned char  description[32]; /* resource description          */
    unsigned char  reserv1[16];    /* reserved                      */
    unsigned char  reserv3[4];     /* reserved                      */
    AP_UINT16      num_lus;        /* number of LUs to add         */
    unsigned char  lu_names[10][8]; /* LU names                     */
} DEFINE_LU_POOL;
```

### Supplied parameters

The application supplies the following parameters:

#### ***opcode***

AP\_DEFINE\_LU\_POOL

#### ***pool\_name***

Name of the LU pool. This is an 8-byte type-A EBCDIC string, padded on the right with EBCDIC spaces if the name is shorter than 8 bytes. If a pool of this name is not already defined, CS/AIX creates it.

#### ***description***

A null-terminated text string (0-31 characters followed by a null character) describing the pool. This string is for information only; it is stored in the node's configuration file and returned on the QUERY\_LU\_POOL verb, but CS/AIX does not make any other use of it.

#### ***num\_lus***

Number of LUs to be added to the pool. This can be zero to define the pool without adding any LUs, or 1-10. To create a pool containing more than 10 LUs, issue multiple DEFINE\_LU\_POOL verbs for the same pool name.

#### ***lu\_names***

Names of the LUs that are being assigned to the pool. Each of these LUs must already be defined to CS/AIX as an LU of type 0-3. Each LU name is an 8-byte type-A EBCDIC string (starting with a letter), padded on the right with EBCDIC spaces.

If a specified LU is currently assigned to a different pool, CS/AIX removes it from that pool (because an LU cannot be in more than one pool) and assigns it to the pool specified by this verb.

### Returned parameters: successful execution

If the verb executes successfully, CS/AIX returns the following parameters:

#### ***primary\_rc***

AP\_OK

### Returned parameters: parameter check

If the verb does not execute because of a parameter error, CS/AIX returns the following parameters:



**primary\_rc**

AP\_PARAMETER\_CHECK

**secondary\_rc**

Possible values are:

**AP\_INVALID\_LU\_NAME**

One or more of the supplied LU names did not match any defined LU name.

**AP\_INVALID\_POOL\_NAME**The *pool\_name* parameter contained a character that was not valid.**AP\_INVALID\_NUM\_LUS**The *num\_lus* parameter was not set to a valid value.

Appendix B, “Common return codes,” on page 661 lists further secondary return codes associated with AP\_PARAMETER\_CHECK, which are common to all NOF verbs.

**Returned parameters: state check**

If the verb does not execute because of a state error, CS/AIX returns the following parameters.

**primary\_rc**

AP\_STATE\_CHECK

**secondary\_rc****AP\_LU\_NAME\_POOL\_NAME\_CLASH**

The specified pool name clashes with the name of an LU.

Appendix B, “Common return codes,” on page 661 lists further secondary return codes associated with AP\_STATE\_CHECK, which are common to all NOF verbs.

**Returned parameters: other conditions**

Appendix B, “Common return codes,” on page 661 lists further combinations of primary and secondary return codes that are common to all NOF verbs.

**DEFINE\_MODE**

The DEFINE\_MODE verb defines a mode (a set of networking characteristics to be used by a group of sessions) or modifies a previously defined mode. You cannot modify the SNA-defined mode CPSVCMG or change the COS name used by the SNA-defined mode SNASVCMG.

If you use this verb to modify an existing mode, the changes will apply to any new combination of local LU and partner LU that start to use the mode after you have made the change. However, any combination of LUs already using the mode will not pick up the changes until after the next locally or remotely initiated CNOS command.

This verb can also be used to specify the default COS to which any unrecognized modes will be mapped. If no default COS is specified, the SNA-defined COS #CONNECT is used.

**VCB structure**

```
typedef struct define_mode
{
    AP_UINT16      opcode;                /* verb operation code          */
    unsigned char  reserv2;               /* reserved                      */
    unsigned char  format;               /* reserved                      */
    AP_UINT16      primary_rc;           /* primary return code          */
    AP_UINT32      secondary_rc;         /* secondary return code        */
    unsigned char  mode_name[8];         /* mode name                    */
    AP_UINT16      reserv3;              /* reserved                      */
    MODE_CHARS     mode_chars;           /* mode characteristics          */
} DEFINE_MODE;
```

## DEFINE\_MODE

```
typedef struct mode_chars
{
    unsigned char    description[32];        /* resource description          */
    unsigned char    reserv2[16];          /* reserved                      */
    AP_UINT16        max_ru_size_upp;      /* maximum RU size upper bound  */
    unsigned char    receive_pacing_win;   /* receive pacing window        */
    unsigned char    default_ru_size;      /* default RU size to maximize  */
                                                /* performance                  */
    AP_UINT16        max_neg_sess_lim;     /* maximum negotiable session limit*/
    AP_UINT16        plu_mode_session_limit; /* LU-mode session limit      */
    AP_UINT16        min_conwin_src;       /* minimum source contention winner*/
                                                /* sessions                    */
    unsigned char    cos_name[8];          /* class of service name        */
    unsigned char    cryptography;         /* reserved                      */
    unsigned char    compression;         /* data compression supported?  */
    AP_UINT16        auto_act;             /* initial auto-activation count */
    AP_UINT16        min_conloser_src;     /* min source contention loser   */
    AP_UINT16        max_ru_size_low;      /* maximum RU size lower bound  */
    AP_UINT16        max_receive_pacing_win; /* maximum receive pacing window */
    unsigned char    max_compress_lvl;     /* max level of data compression */
    unsigned char    max_decompress_lvl;   /* max level of data decompression */
    unsigned char    comp_in_series;       /* reserved                      */
    unsigned char    reserv4[25];         /* reserved                      */
} MODE_CHARS;
```

## Supplied parameters

The application supplies the following parameters:

### ***opcode***

AP\_DEFINE\_MODE

### ***mode\_name***

Name of the mode. This is an 8-byte type-A EBCDIC string, padded on the right with EBCDIC spaces if the name is shorter than 8 bytes. The name must start with a letter, or can start with # for one of the SNA-defined modes such as #INTER. For information about SNA-defined modes, see the *IBM Communications Server for Data Center Deployment on AIX Administration Guide*.

To specify the default COS that will be used for any unrecognized mode names, set this parameter to 8 binary zeros. In this case, the *mode\_chars.cos\_name* parameter is taken as the default COS name; all other parameters supplied on this verb are ignored.

### ***mode\_chars.description***

A null-terminated text string (0-31 characters followed by a null character) describing the mode. This string is for information only; it is stored in the node's configuration file and returned on the QUERY\_MODE\_DEFINITION and QUERY\_MODE verbs, but CS/AIX does not make any other use of it.

### ***mode\_chars.max\_ru\_size\_upp***

Upper bound for the maximum size of RUs sent and received on sessions in this mode. The value is used when the maximum RU size is negotiated during session activation.

Range: 256-61,440. If the *default\_ru\_size* parameter (see below) is set to AP\_YES, this parameter is ignored (and the value is not checked).

### ***mode\_chars.receive\_pacing\_win***

Session pacing window for sessions using this mode; the range is 1-63. This value is used only for fixed pacing (not for adaptive pacing), and specifies the maximum number of frames that can be received from the partner LU before the local LU must send a response. CS/AIX always uses adaptive pacing unless the adjacent node specifies that it is not supported.

### ***mode\_chars.default\_ru\_size***

Specifies whether a default upper bound for the maximum RU size will be used. Possible values are:

#### **AP\_YES**

CS/AIX ignores the *max\_ru\_size\_upp* parameter, and sets the upper bound for the maximum RU size to the largest value that can be accommodated in the link BTU size.

#### **AP\_NO**

CS/AIX uses the *max\_ru\_size\_upp* parameter to define the maximum RU size.

***mode\_chars.max\_neg\_sess\_lim***

Maximum number of sessions allowed on this mode between any local LU and partner LU. This value may be lowered for a particular LU-LU-mode combination when issuing *initialize\_session\_limit* or *change\_session\_limit*.

Range: 1-32,767. Zero indicates that CS/AIX should not initiate implicit CNOS exchange when an application attempts to start a session using this mode; session limits must be specified explicitly using *initialize\_session\_limit*.

***mode\_chars.plu\_mode\_session\_limit***

Default session limit for this mode. This limits the number of sessions on this mode between any one local LU and partner LU pair. This value is used when CNOS (Change Number of Sessions) exchange is initiated implicitly.

Specify a value in the range 1-32,767 (which must not exceed the value in *max\_neg\_sess\_lim*). Zero indicates that CS/AIX should not initiate implicit CNOS exchange when an application attempts to start a session using this mode; session limits must be specified explicitly using *initialize\_session\_limit*.

If you specify an explicit limit, the LU session limit for any LU that uses this mode must be greater than or equal to the sum of the session limits for all modes that the LU will use.

***mode\_chars.min\_conwin\_src***

Minimum number of contention winner sessions that a local LU using this mode can activate. This value is used when CNOS (Change Number of Sessions) exchange is initiated either by the remote system or implicitly by CS/AIX. Specify a value in the range 0-32,767. The sum of the *min\_conwin\_src* and *min\_conloser\_src* parameters must not exceed *plu\_mode\_session\_limit*.

***mode\_chars.cos\_name***

Name of the class of service to request when activating sessions on this mode.

If the node supports mode to COS mapping (as defined by the *mode\_to\_cos\_map\_supp* parameter on DEFINE\_NODE), the COS specified by this field must be either an SNA defined COS or a COS previously defined by issuing a DEFINE\_COS verb. Otherwise, this parameter is ignored.

The name is an 8-byte type-A character string, padded on the right with spaces if the name is shorter than 8 characters.

***mode\_chars.compression***

Specifies whether sessions activated using this mode can use compression. Possible values are:

**AP\_COMP\_PROHIBITED**

Compression is not supported for sessions using this mode.

**AP\_COMP\_REQUESTED**

Compression is supported and requested for sessions using this mode. (It is not mandatory; compression will not be used if the BIND from the partner does not request it.)

***mode\_chars.auto\_act***

Number of sessions that will be activated automatically for this mode. This value is used when CNOS (Change Number of Sessions) exchange is initiated implicitly. Specify a value in the range 0-32,767.

***mode\_chars.min\_conloser\_src***

Minimum number of contention loser sessions that can be activated by any one local LU that uses this mode. This value is used when CNOS (Change Number of Sessions) exchange is initiated implicitly. Specify a value in the range 0-32,767. The sum of the *min\_conwin\_src* and *min\_conloser\_src* parameters must not exceed *plu\_mode\_session\_limit*.

***mode\_chars.max\_ru\_size\_low***

Lower bound for the maximum size of RUs sent and received on sessions that use this mode. Specify a value in the range 256-61,440. The value 0 means that there is no lower bound.

The value is used when the maximum RU size is negotiated during session activation. This parameter is ignored if the *default\_ru\_size* parameter is set to AP\_YES.

## DEFINE\_MODE

### ***mode\_chars.max\_receive\_pacing\_win***

Maximum session pacing window for sessions in this mode. For adaptive pacing, this value is used to limit the receive pacing window that the session will grant. For fixed pacing, this parameter is not used. (CS/AIX always uses adaptive pacing unless the adjacent node specifies that it does not support it.)

Specify a value in the range 0-32,767. The value zero means that there is no upper bound.

### ***mode\_chars.max\_compress\_lvl***

Specifies the maximum level of compression that CS/AIX will attempt to negotiate for data flowing from the local node. Possible values are:

- AP\_NONE
- AP\_RLE\_COMPRESSION
- AP\_LZ9\_COMPRESSION
- AP\_LZ10\_COMPRESSION

If compression is negotiated using a non-extended BIND, which does not specify a maximum compression level, RLE compression will be used.

### ***mode\_chars.max\_decompress\_lvl***

Specifies the maximum level of decompression that CS/AIX will attempt to negotiate for data flowing into the local node. Possible values are:

- AP\_NONE
- AP\_RLE\_COMPRESSION
- AP\_LZ9\_COMPRESSION
- AP\_LZ10\_COMPRESSION

If compression is negotiated using a non-extended BIND, which does not specify a maximum compression level, RLE compression will be used.

## Returned parameters: successful execution

If the verb executes successfully, CS/AIX returns the following parameters:

### ***primary\_rc***

AP\_OK

## Returned parameters: parameter check

If the verb does not execute because of a parameter error, CS/AIX returns the following parameters:

### ***primary\_rc***

AP\_PARAMETER\_CHECK

### ***secondary\_rc***

Possible values are:

#### **AP\_CPSVCMG\_ALREADY\_DEFD**

The SNA-defined mode CPSVCMG cannot be changed.

#### **AP\_INVALID\_CNOS\_SLIM**

The *plu\_mode\_session\_limit* parameter is not valid.

#### **AP\_INVALID\_COMPRESSION**

The *compression* parameter is not valid.

#### **AP\_INVALID\_COS\_NAME**

The *cos\_name* parameter did not match any defined COS name.

#### **AP\_INVALID\_COS\_SNASVCMG\_MODE**

The COS for the SNA-defined mode SNASVCMG cannot be changed.

**AP\_INVALID\_DEFAULT\_RU\_SIZE**

The *default\_ru\_size* parameter was not in the valid range.

**AP\_INVALID\_MAX\_COMPRESS\_LVL**

The *max\_compress\_lvl* parameter is not valid.

**AP\_INVALID\_MAX\_DECOMPRESS\_LVL**

The *max\_decompress\_lvl* parameter is not valid.

**AP\_INVALID\_MAX\_NEGOT\_SESS\_LIM**

The *max\_neg\_sess\_lim* parameter was not in the valid range.

**AP\_INVALID\_MAX\_RU\_SIZE\_UPPER**

The *max\_ru\_size\_upp* parameter was not in the valid range.

**AP\_INVALID\_MIN\_CONLOSERS**

The *min\_conloser\_src* parameter was not in the valid range, or was greater than *plu\_mode\_session\_limit*.

**AP\_INVALID\_MIN\_CONWINNERS**

The *min\_conwin\_src* parameter was not in the valid range, or was greater than *plu\_mode\_session\_limit*.

**AP\_INVALID\_MIN\_CONTENTION\_SUM**

The sum of the *min\_conwin\_src* and *min\_conloser\_src* parameters was greater than *plu\_mode\_session\_limit*.

**AP\_INVALID\_MODE\_NAME**

The *mode\_name* parameter contained a character that was not valid.

**AP\_INVALID\_RECV\_PACING\_WINDOW**

The *receive\_pacing\_win* parameter was not in the valid range.

**AP\_INVALID\_SNASVCMG\_MODE\_LIMIT**

The SNA-defined mode SNASVCMG must have a session limit of 2 and *min\_conwin\_src* of 1. You cannot define SNASVCMG with different values for these parameters.

**AP\_MODE\_SESS\_LIM\_EXCEEDS\_NEG**

The value specified for *plu\_mode\_session\_limit* was larger than the value specified for *max\_neg\_sess\_lim*.

Appendix B, “Common return codes,” on page 661 lists further secondary return codes associated with AP\_PARAMETER\_CHECK, which are common to all NOF verbs.

## Returned parameters: other conditions

Appendix B, “Common return codes,” on page 661 lists further combinations of primary and secondary return codes that are common to all NOF verbs.

## DEFINE\_NODE

An application issues this verb in order to define a new node, or to modify the parameters of an inactive node.

This verb must be issued to a server where the node is not running. It cannot be issued to a running node.

## VCB structure

```
typedef struct define_node
{
  AP_UINT16      opcode;          /* verb operation code          */
  unsigned char  reserv2;        /* reserved                      */
  unsigned char  format;        /* reserved                      */
  AP_UINT16      primary_rc;     /* primary return code          */
  AP_UINT32      secondary_rc;   /* secondary return code        */
  unsigned char  node_name[128]; /* name of Node                 */
  AP_UINT32      target_handle;  /* handle for subsequent verbs  */
}
```

## DEFINE\_NODE

```
CP_CREATE_PARMS cp_create_parms; /* CP create parameters */
} DEFINE_NODE;

typedef struct cp_create_parms
{
    AP_UINT16 crt_parms_len; /* length of CP_CREATE_PARMS */
    unsigned char description[32]; /* resource description */
    unsigned char reserv1[2]; /* reserved */
    unsigned char ms_support; /* reserved */
    unsigned char queue_nmvt; /* reserved */
    unsigned char reserv3[12]; /* reserved */
    unsigned char node_type; /* node type */
    unsigned char fqcp_name[17]; /* fully qualified CP name */
    unsigned char cp_alias[8]; /* CP alias */
    unsigned char mode_to_cos_map_supp; /* mode to COS mapping support */
    unsigned char mds_supported; /* MDS and MS capabilities */
    unsigned char node_id[4]; /* node ID */
    AP_UINT16 max_locates; /* maximum locates node can process */
    AP_UINT16 dir_cache_size; /* directory cache size (reserved
    /* is not NN)
    AP_UINT16 max_dir_entries; /* maximum directory entries (zero
    /* means unlimited)
    AP_UINT16 locate_timeout; /* locate timeout in seconds */
    unsigned char reg_with_nn; /* register resources with NNS */
    unsigned char reg_with_cds; /* register resources with CDS */
    AP_UINT16 mds_send_alert_q_size; /* size of MDS send alert queue */
    AP_UINT16 cos_cache_size; /* number of cos definitions */
    AP_UINT16 tree_cache_size; /* Topology Database routing tree
    /* cache size
    AP_UINT16 tree_cache_use_limit; /* number of times a tree can be used */
    AP_UINT16 max_fdm_nodes; /* max number of nodes that can be
    /* stored in Topology Database
    AP_UINT16 max_tdm_tgs; /* max number of TGs that can be
    /* stored in Topology Database
    AP_UINT32 max_isr_sessions; /* maximum ISR sessions */
    AP_UINT32 isr_sessions_upper_threshold; /* upper threshold for ISR
    /* sessions
    AP_UINT32 isr_sessions_lower_threshold; /* lower threshold for ISR
    /* sessions
    AP_UINT16 isr_max_ru_size; /* max RU size for ISR */
    AP_UINT16 isr_rcv_pac_window; /* ISR receive pacing window size */
    unsigned char store_endpt_rscvs; /* endpoint RSCV storage */
    unsigned char store_isr_rscvs; /* ISR RSCV storage */
    unsigned char store_dlur_rscvs; /* DLUR RSCV storage */
    unsigned char dlur_support; /* is DLUR supported? */
    unsigned char pu_conc_support; /* is PU conc supported? */
    unsigned char nn_rar; /* Route additional resistance */
    unsigned char hpr_support; /* Level of hpr support */
    unsigned char mobile; /* reserved */
    unsigned char discovery_support; /* reserved */
    unsigned char discovery_group_name[8]; /* reserved */
    unsigned char implicit_lu_0_to_3; /* reserved */
    unsigned char default_preference; /* reserved */
    unsigned char anynet_supported; /* reserved */
    AP_UINT16 max_ls_exception_events; /* Max # exception entries */
    unsigned char comp_in_series; /* reserved */
    unsigned char max_compress_lvl; /* reserved */
    unsigned char node_spec_data_len; /* reserved */
    unsigned char ptf[64]; /* program temporary fix array */
    unsigned char cos_table_version; /* version of COS tables to use */
    unsigned char send_term_self; /* default PLU-SLU session term */
    unsigned char disable_branch_awareness; /* disable BrNN awareness */
    unsigned char cplu_syncpt_support; /* syncpoint support on CP LU? */
    unsigned char cplu_attributes; /* attributes for CP LU */
    unsigned char reserved[95]; /* reserved */
} CP_CREATE_PARMS;
```

## Supplied parameters

### *opcode*

AP\_DEFINE\_NODE

### *node\_name*

Name of CS/AIX node that the application wishes to define.

If the node name includes a . (period) character, CS/AIX assumes that it is a fully-qualified name; otherwise it performs a DNS lookup to determine the node name.

***cp\_create\_parms.crt\_parms\_len***

Length of create parameters structure.

***cp\_create\_parms.description***

A text string (0-31 characters followed by a null character) describing the node. This string is for information only; it is stored in the node's configuration file and returned on the QUERY\_NODE verb, but CS/AIX does not make any other use of it.

***cp\_create\_parms.node\_type***

One of the following node types:

AP\_NETWORK\_NODE

AP\_BRANCH\_NETWORK\_NODE

AP\_END\_NODE

AP\_LEN\_NODE

***cp\_create\_parms.fqcp\_name***

Node's fully qualified CP name. The name is a 17-byte EBCDIC string, right-padded with EBCDIC spaces. It consists of a network ID of up to 8 A-string characters, an EBCDIC dot (period) character, and a network name of up to 8 A-string characters.

***cp\_create\_parms.cp\_alias***

Locally used CP alias. This alias can be used by APPC applications to access the CP LU. This is an 8-byte ASCII string. All 8 bytes are significant and must be set.

***cp\_create\_parms.mode\_to\_cos\_map\_supp***

Specifies whether the node provides mode-to-COS mapping. This parameter is ignored for a network node; mode-to-COS mapping is always supported. For a LEN node, mode-to-COS mapping is not supported. Possible values are:

**AP\_YES**

Mode-to-COS mapping is supported. A mode defined for this node must include an associated COS name, which specifies either an SNA-defined COS or one defined using DEFINE\_COS.

**AP\_NO**

Mode-to-COS mapping is not supported. Default COS names will be used.

***cp\_create\_parms.mds\_supported***

Specifies whether Management Services supports Multiple Domain Support and MS Capabilities. Possible values are:

**AP\_YES**

MDS is supported.

**AP\_NO**

MDS is not supported.

***cp\_create\_parms.node\_id***

Node identifier used in XID exchange. This is a 4-byte hexadecimal string, consisting of a block number (3 hexadecimal digits) and a node number (5 hexadecimal digits).

***cp\_create\_parms.max\_locates***

Maximum number of locate requests that the node can process simultaneously. When the number of outstanding locate requests (requests for which a response has not yet been received) reaches this limit, any further locate requests are rejected. The minimum is 8.

***cp\_create\_parms.dir\_cache\_size***

Network node only: Size of the directory cache. The minimum value is 3. You can use the information returned on QUERY\_DIRECTORY\_STATS to help determine the appropriate size.

***cp\_create\_parms.max\_dir\_entries***

Maximum number of directory entries. Specify zero for no limit.

***cp\_create\_parms.locate\_timeout***

Specifies the time in seconds before a network search will timeout. Specify zero for no timeout.

## DEFINE\_NODE

### ***cp\_create\_parms.reg\_with\_nn***

Specifies whether to register the node's resources with the network node server when the node is started. Note that the valid values for this parameter are different depending on whether the node is an End Node or a Branch Network Node. If the local node is a Network Node or a LEN Node, this parameter is reserved.

Possible values for End Node:

#### **AP\_YES**

Register resources with the NN. The end node's network node server will only forward directed locates to it.

#### **AP\_NO**

Do not register resources. The network node server will forward all broadcast searches to the end node.

Possible values for Branch Network Node:

#### **AP\_REGISTER\_NONE**

The local node does not register any LUs with the NN Server. The NN Server will forward all broadcast searches to the branch network node.

#### **AP\_REGISTER\_ALL**

The local node registers all domain independent LUs with the NN Server; it also registers all local dependent LUs if the NN Server supports option set 1116. The NN Server will only forward directed locates to it (unless it owns dependent LUs that could not be registered).

#### **AP\_REGISTER\_LOCAL\_ONLY**

The local node registers all local independent LUs with the NN Server; it also registers all local dependent LUs if the NN Server supports option set 1116. The NN Server will forward all broadcast searches to the branch network node.

### ***cp\_create\_parms.reg\_with\_cds***

End node: Specifies whether the network node server is allowed to register end node resources with a Central Directory server. This field is ignored if *reg\_with\_nn* is set to AP\_NO.

Network node: Specifies whether local or domain resources can be optionally registered with Central Directory server.

Possible values are:

#### **AP\_YES**

Register resources with the CDS.

#### **AP\_NO**

Do not register resources.

Branch network node: Specifies whether BrNN resources (local to the Branch Network Node or from its domain) can be registered with Central Directory Server by the Network Server. This field is ignored if *reg\_with\_nn* is set to AP\_REGISTER\_NONE.

Possible values are:

#### **AP\_YES**

Register resources with the CDS.

#### **AP\_NO**

Do not register resources.

### ***cp\_create\_parms.mds\_send\_alert\_q\_size***

Size of the MDS send alert queue. If the number of queued alerts reaches this limit, CS/AIX deletes the oldest alert on the queue. CS/AIX uses the value 2 unless you specify a larger number.

### ***cp\_create\_parms.cos\_cache\_size***

Size of the COS Database weights cache. This value should be set to the maximum number of COS definitions required. CS/AIX uses the value 8 unless you specify a larger number.



***cp\_create\_parms.tree\_cache\_size***

Network node: Size of the Topology Database routing tree cache size. The minimum is 8. For an end node or LEN node, this parameter is reserved.

***cp\_create\_parms.tree\_cache\_use\_limit***

Network node: Maximum number of uses of a cached tree. Once this number is exceeded, the tree is discarded and recomputed. This allows the node to balance sessions among equal weight routes. A low value provides better load balancing at the expense of increased activation latency. The minimum is 1. For an end node or LEN node, this parameter is reserved.

***cp\_create\_parms.max\_tdm\_nodes***

Network node: Maximum number of nodes that can be stored in Topology Database (zero means unlimited). For an end node or LEN node, this parameter is reserved.

***cp\_create\_parms.max\_tdm\_tgs***

Network node: Maximum number of TGs that can be stored in Topology Database (zero means unlimited). For an end node or LEN node, this parameter is reserved.

***cp\_create\_parms.max\_isr\_sessions***

Network node: Maximum number of ISR sessions the node can participate in at once. CS/AIX uses the value 100 unless you specify a larger number. For an end node or LEN node, this parameter is reserved.

***cp\_create\_parms.isr\_sessions\_upper\_threshold, cp\_create\_parms.isr\_sessions\_lower\_threshold***

Network node: These thresholds control the node's congestion status, which is reported to other nodes in the network for use in route calculations. The node state changes from uncongested to congested if the number of ISR sessions exceeds the upper threshold. The node state changes back to uncongested once the number of ISR sessions dips below the lower threshold. The lower threshold must be less than the upper threshold, and the upper threshold must be lower than *max\_isr\_sessions*. For an end node or LEN node, this parameter is reserved.

***cp\_create\_parms.isr\_max\_ru\_size***

Network node or BrNN: Maximum RU size supported for intermediate or DLUR LU-LU sessions. If the supplied value is not a valid RU size (as described in *Systems Network Architecture: Formats*), CS/AIX will round the value up to the next valid value.

End node: Maximum RU size supported for DLUR LU-LU sessions.

For a LEN node, this parameter is reserved.

***cp\_create\_parms.isr\_rcv\_pac\_window***

Network node: Suggested receive pacing window size for intermediate sessions, in the range 1-63. This value is only used on the secondary hop of intermediate sessions if the adjacent node does not support adaptive pacing. For an end node or LEN node, this parameter is reserved.

***cp\_create\_parms.store\_endpt\_rscvs***

Specifies whether RSCVs should be stored for diagnostic purposes (AP\_YES or AP\_NO). If this field is set to AP\_YES, then an RSCV will be returned on the QUERY\_SESSION verb. (Setting this value to AP\_YES means an RSCV will be stored for each endpoint session. This extra storage can be up to 256 bytes per session.)

***cp\_create\_parms.store\_isr\_rscvs***

Network node: Specifies whether RSCVs should be stored for diagnostic purposes (AP\_YES or AP\_NO). If this field is set to AP\_YES, then an RSCV will be returned on the QUERY\_ISR\_SESSION verb. (Setting this value to AP\_YES means an RSCV will be stored for each ISR session. This extra storage can be up to 256 bytes per session.) For an end node or LEN node, this parameter is reserved.

***cp\_create\_parms.store\_dlur\_rscvs***

Specifies whether RSCVs should be stored for diagnostic purposes (AP\_YES or AP\_NO). If this field is set to AP\_YES, then an RSCV will be returned on the QUERY\_DLUR\_LU verb. (Setting this value to AP\_YES means an RSCV will be stored for each PLU-SLU session using DLUR. This extra storage can be up to 256 bytes per session.)

***cp\_create\_parms.dlur\_support***

Specifies whether DLUR is supported. For a LEN node, this parameter is reserved. Possible values are:

## DEFINE\_NODE

### **AP\_YES**

DLUR is supported.

### **AP\_LIMITED\_DLUR\_MULTI\_SUBNET | AP\_YES**

End Node or Branch Network Node: DLUR is supported, but will not be used to connect to a DLUS in another subnet. If multi-subnet operation is not required, you should use this value instead of AP\_YES, to reduce network traffic and congestion at the network node.

This value is not supported for a Network Node.

### **AP\_NO**

DLUR is not supported.

### ***cp\_create\_parms.pu\_conc\_support***

Specifies whether SNA gateway is supported (AP\_YES or AP\_NO).

If the node will be used to run Primary RUI applications communicating with downstream LUs, this parameter must be set to AP\_YES.

### ***cp\_create\_parms.nn\_rar***

The network node's route additional resistance, in the range 0-255.

### ***cp\_create\_parms.hpr\_support***

Specifies the level of HPR (High Performance Routing) support provided by the node. Possible values are:

#### **AP\_NONE**

No support for HPR.

#### **AP\_BASE**

This node can perform automatic network routing (ANR) but cannot act as an RTP (Rapid Transport Protocol) end point for HPR sessions.

#### **AP\_RTP**

This node can perform automatic network routing (ANR) and can act as an RTP (Rapid Transport Protocol) end point for HPR sessions.

#### **AP\_CONTROL\_FLOWS**

This node can perform all HPR functions including control flows.

If the local node is a LEN node, this parameter should be set to AP\_NONE. Otherwise the recommended setting is AP\_CONTROL\_FLOWS.

If you are using Enterprise Extender (HPR/IP) links on this node, this parameter must be set to AP\_CONTROL\_FLOWS.

### ***cp\_create\_parms.max\_ls\_exception\_events***

The maximum number of LS exception events to be recorded by the node.

### ***cp\_create\_parms.ptf***

Array for configuring and controlling future program temporary fix (ptf) operation, as follows:

### ***cp\_create\_parms.ptf[0]***

REQDISCONT support and Mandatory Search Status support.

CS/AIX normally uses REQDISCONT to deactivate limited resource host links that are no longer required by session traffic. This byte can be used to suppress use of REQDISCONT, or to modify the settings used on REQDISCONT requests sent by CS/AIX. Set this byte to one of the following values:

#### **AP\_NONE**

Use the normal REQDISCONT support.

#### **AP\_SUPPRESS\_REQDISCONT**

Do not use REQDISCONT.

#### **AP\_OVERRIDE\_REQDISCONT**

Use a modified version of REQDISCONT support. If REQDISCONT is specified, it must be combined with one or both of the following values, using a logical OR operation:

**AP\_REQDISCONT\_TYPE**

Use type "immediate" on REQDISCONT; if this value is not specified, CS/AIX uses type "normal".

**AP\_REQDISCONT\_RECONTACT**

Use type "immediate recontact" on REQDISCONT; if this value is not specified, CS/AIX uses type "no immediate recontact".

When CS/AIX is running as an End Node or as a Branch Network Node, it may choose whether or not to invite network searches from its Network Node Server (NNS). Requesting network searches slows broadcast search processing for the network as a whole, so is undesirable. However, if the local node cannot register all its resources (LUs) with its NNS, requesting searches is the only way to make these resources visible to the network.

Normally, CS/AIX determines whether all LUs can be registered, then intelligently requests network searches from its NNS. If this node makes LUs accessible to the network in an unusual manner (for example, if it is acting as a gateway for other nodes), combine the value above with the following value to override the standard operation:

**AP\_SET\_SEARCH\_STATUS**

Unconditionally request network searches from the NNS.

***cp\_create\_parms.ptf[1]***

ERP support. CS/AIX normally processes an ACTPU(ERP) as an ERP; this resets the PU-SSCP session, but does not implicitly deactivate the subservient LU-SSCP and PLU-SLU sessions. SNA implementations may legally process ACTPU(ERP) as if it were ACTPU(cold), implicitly deactivating the subservient LU-SSCP and PLU-SLU sessions. Set this byte to one of the following values:

**AP\_NONE**

Use the normal processing.

**AP\_OVERRIDE\_ERP**

Process all ACTPU requests as ACTPU(cold).

***cp\_create\_parms.ptf[2]***

LU 6.2 session activation and deactivation. CS/AIX normally does not include the ENQUEUE parameter on the INIT\_SELF message when activating a dependent LU 6.2 session, and uses the BIS protocol prior to deactivating a limited resource LU 6.2 session.

To use the normal processing, set this parameter to AP\_NONE.

To customize LU 6.2 session activation and deactivation, specify one of the following values:

**AP\_SUPPRESS\_BIS**

Do not use the BIS protocol. Limited resource LU 6.2 sessions are deactivated immediately using UNBIND(cleanup).

**AP\_LU62\_INIT\_SELF\_ENQUEUE**

Use the old format of the INIT\_SELF message, which includes the ENQUEUE parameter.

***cp\_create\_parms.ptf[3]***

APINGD support. CS/AIX normally includes a partner program for the APING connectivity tester. This byte allows you to disable the APING Daemon within the node, so that requests by an APING program arriving at the node will not be processed automatically. Set this byte to one of the following values:

**AP\_NONE**

Include APINGD support within the node (the normal processing).

**AP\_EXTERNAL\_APINGD**

Disable APINGD within the node.

***cp\_create\_parms.ptf[4]***

LU 0-3 RU checks. This byte is used to provide workarounds for host systems that send non-standard SNA data; it should be set to AP\_NONE unless you have encountered the specific problem described below.

To use CS/AIX's normal checking on LU 0-3 RUs, set this parameter to AP\_NONE.

## DEFINE\_NODE

To relax specific checks on LU 0-3 RUs, specify the following value:

### **AP\_ALLOW\_BB\_RQE**

The SNA protocols state that BB !EB RUs on LU 0-3 PLU-SLU sessions must be RQD. Several hosts send RQE BB !EB CD - a protocol violation which CS/AIX always tolerates. If this value is set, CS/AIX will tolerate RQE BB !EB !CD EC RUs as well.

### **AP\_SEND\_ACTLU\_POWER\_ON**

When an application is using an LU 0-3 LU (for example if RUI\_INIT has been received for the LU) and ACTLU is received, this option indicates that CS/AIX should respond with a +ve RSP ACTLU containing the power on subvector. Without this flag CS/AIX sends an ACTLU RSP without this subvector and a subsequent NOTIFY message indicating the power on condition.

### ***cp\_create\_parms.ptf[5]***

Security checking for received Attaches.

If a local invocable TP is defined not to require conversation security, or is not defined and therefore defaults to not requiring conversation security, the invoking TP need not send a user ID and password to access it. If the invoking TP supplies these parameters and they are included in the Attach message that CS/AIX receives, CS/AIX normally checks the parameters (and rejects the Attach if they are not valid) even though the invocable TP does not require conversation security. This parameter allows you to disable the checking. Set this byte to one of the following values:

### **AP\_NONE**

Always check security parameters if they are included on a received Attach, regardless of the security requirements of the invocable TP (the normal processing).

### **AP\_LIMIT\_TP\_SECURITY**

Do not check security parameters on a received Attach if the invocable TP does not require it.

### ***cp\_create\_parms.ptf[6]***

RTP options for HPR.

To use normal RTP processing, so that CS/AIX will use the best available RTP mechanism according to the capability of the remote system, set this parameter to AP\_NONE.

To customize RTP operation, specify one of the following values:

### **AP\_NO\_PROGRESSIVE\_ARB**

If this value is set, CS/AIX will advertise support for the standard and responsive mode ARB algorithms but not for the progressive mode algorithm.

### ***cp\_create\_parms.ptf[7]***

DLUR unbind on DACTLU. CS/AIX does not normally end the PLU-SLU session when it receives a DACTLU from the host for a session using DLUR. Set this byte to one of the following values:

### **AP\_NONE**

Use the normal processing.

### **AP\_DLUR\_UNBIND\_ON\_DACTLU**

When DACTLU is received on a session using DLUR, end the PLU-SLU session.

### ***cp\_create\_parms.ptf[8]***

Suppress PU name on REQACTPU. CS/AIX identifies the PU name in the REQACTPU message when activating DLUR PUs. Set this byte to one of the following values:

### **AP\_NONE**

Use the normal processing.

### **AP\_SUPPRESS\_PU\_NAME\_ON\_REQACTPU**

Suppress PU name when activating DLUR PUs.

### **AP\_RETRY\_CNOS\_ON\_BIND\_NEG\_RSP**

During APPC session activation, the CNOS session activation can fail due to transitory conditions on the partner system. Some conditions indicated by particular sense codes are always retried (with a timer). Setting this flag ensures that CS/AIX will always retry failed CNOS session activations.

***cp\_create\_parms.ptf[9]***

RUI bracket race options, limited resource override options for connection networks, and TCP/IP Information Control Vector options.

If an RUI application is using bracket protocols, and the host sends a BB (Begin Bracket) after the RUI application has already sent one, CS/AIX normally rejects this with sense data of 0813 and does not pass it to the application. Set this byte to one of the following values:

**AP\_NONE**

Use the normal processing.

**AP\_LUA\_PASSTHRU\_BB\_RACE**

Pass the BB through to the RUI application. The application should send a negative response with sense data of either 0813 or 0814.

A link in CS/AIX that uses a connection network is normally a limited resource. To override this, combine the value above with the following value:

**AP\_CN\_OVERRIDE\_LIM\_RES**

Use the *implicit\_limited\_resource* parameter in the port associated with each connection network link to determine whether it is a limited resource.

CS/AIX normally includes the TCP/IP Information Control Vector (0x64) in a NOTIFY request to the host for a TN3270 or LUA session. This vector contains information that can be displayed on the host console or used by the host (for example in billing): the TCP/IP address and port number used by the client, and the IP name corresponding to the client address. For TN3270, the TN3270 server normally performs a Domain Name Server (DNS) lookup to determine the client IP name.

If the client address is an IPv6 address but the host is running a back-level version of VTAM that cannot interpret IPv6 addresses, the client address may be displayed incorrectly on the host console.

The following flags allow you to override this behavior. To do this, combine the value above with one of the following values:

**AP\_NO\_TCPIP\_VECTOR**

Do not include the TCP/IP Information Control Vector (0x64) in NOTIFY requests to the host for either TN3270 or LUA.

Use this value if the host is running an older version of VTAM that does not support this control vector.

**AP\_NO\_TCPIP\_NAME**

Do not perform the DNS lookup, and send the CV64 control vector with the client IP address but no IP name.

This value applies only to TN3270; no DNS lookup is required for LUA clients. Use this value if the DNS environment is slow, or if you know that the clients are not included in the DNS data (for example if they are DHCP clients without DDNS).

***cp\_create\_parms.ptf[10]***

Suppress Logical Unit of Work Identifiers (LUWIDs) in FMH-5 Attach messages. CS/AIX normally includes the LUWID in the FMH-5 Attach message that it sends to start an APPC conversation. Set this byte to one of the following values:

**AP\_NONE**

Use the normal processing.

**AP\_DONT\_SEND\_LUWIDS**

Do not include the LUWID in the FMH-5 Attach; specify the field length for this field as zero.

***cp\_create\_parms.ptf[11]***

LU management options.

To use normal LU processing, set this parameter to AP\_NONE.

To customize LU management, specify one of the following values:

**AP\_DLUR\_USE\_REX\_PACING**

When the BIND from an upstream LU requests adaptive pacing with an unlimited pacing window, CS/AIX normally indicates this by specifying a window size of 0 (zero). If the downstream LU does not support adaptive pacing, it may incorrectly interpret this zero value as "no pacing", so CS/AIX must specify a non-zero pacing window size instead. Set this option to use the REX stage pacing value from the ACTLU as the pacing window size specified to the downstream LU.

**AP\_CLI\_OVERWRITE\_SYS\_NAME**

Set this option to maintain the association between an APPC application running on a client and the pooled LU that it uses, so that subsequent conversations started by the partner application can be routed to the correct client. When a client application accesses an LU in a pool, CS/AIX changes the *sys\_name* parameter on the LU to the hostname of the client computer where the application is running. For more information about managing clients, refer to the *IBM Communications Server for Data Center Deployment on AIX Administration Guide*.

**AP\_OVERWRITE\_INTERNAL\_PU\_PARMS**

Normally, once a DLUR PU is defined, there is no way to modify configuration parameters on that PU without first deleting it (and any associated LUs). Setting this flag permits CS/AIX to accept a fresh definition of a DLUR PU using `snaadmin` providing also that the node is inactive. All non-defaulted parameters must be defined (this is not equivalent to a `snaadmin -c` command).

***cp\_create\_parms.cos\_table\_version***

Specifies the version of the COS tables used by the node. Set this byte to one of the following values:

**AP\_VERSION\_0\_COS\_TABLES**

Use the COS tables originally defined in the APPN Architecture Reference.

**AP\_VERSION\_1\_COS\_TABLES**

Use the COS tables originally defined for HPR over ATM.

***cp\_create\_parms.send\_term\_self***

Specifies the default method for ending a PLU-SLU session to a host. The value you specify is used for all type 0-3 LUs on the node, unless you override it by specifying a different value in the LU definition. Specify one of the following values:

**AP\_YES**

Send a TERM\_SELF on receipt of a CLOSE\_PLU\_SLU\_SEC\_RQ.

**AP\_NO**

Send an UNBIND on receipt of a CLOSE\_PLU\_SLU\_SEC\_RQ.

***cp\_create\_parms.disable\_branch\_awareness***

This parameter applies only if *node\_type* is AP\_NETWORK\_NODE; it is reserved for other node types.

Specify whether the local node supports branch awareness, APPN Option Set 1120, using one of the following values:

**AP\_YES**

The local node does not support branch awareness. TGs between this node and served Branch Network Nodes do not appear in the network topology, and the local node does not report itself as being branch aware.

**AP\_NO**

The local node supports branch awareness.

***cp\_create\_parms.cplu\_syncpt\_support***

Specifies whether the node's Control Point LU supports Syncpoint functions. This parameter is equivalent to the *syncpt\_support* parameter on DEFINE\_LOCAL\_LU, but applies only to the node's Control Point LU (which does not have an explicit LU definition).

Set this parameter to AP\_YES only if you have a Sync Point Manager (SPM) and Conversation Protected Resource Manager (C-PRM) in addition to the standard CS/AIX product. Possible values are:

**AP\_YES**

Syncpoint is supported.

**AP\_NO**

Syncpoint is not supported.

***cp\_create\_parms.cplu\_attributes***

Identifies additional information about the node's Control Point LU. This parameter is equivalent to the *lu\_attributes* parameter on DEFINE\_LOCAL\_LU, but applies only to the node's Control Point LU (which does not have an explicit LU definition).

Possible values are:

**AP\_NONE**

No additional information identified.

**AP\_DISABLE\_PWSUB**

Disable password substitution support for the control point LU. Password substitution means that passwords are encrypted before transmission between the local and remote LUs, rather than being sent as clear text. CS/AIX normally uses password substitution if the remote system supports it.

This value is provided as a work-around for communications with some remote systems that do not implement password substitution correctly. If you use this option, you should be aware that this involves sending and receiving passwords in clear text (which may represent a security risk). Do not set it unless there are problems with the remote system's implementation of password substitution.

**Returned parameters: successful execution**

If the verb executes successfully, CS/AIX returns the following parameters:

***primary\_rc***

AP\_OK

***target\_handle***

Returned value for use on subsequent verbs.

**Returned parameters: parameter check**

If the verb does not execute because of a parameter error, CS/AIX returns the following parameters:

***primary\_rc***

AP\_PARAMETER\_CHECK

***secondary\_rc***

Possible values are:

**AP\_INVALID\_ISR\_THRESHOLDS**

The ISR threshold parameters were not valid (lower threshold above upper, or upper threshold above *max\_isr\_sessions*).

**AP\_INVALID\_NODE\_NAME**

The *node\_name* parameter contained a character that was not valid.

**AP\_INVALID\_CP\_NAME**

The *cp\_alias* or *fqcp\_name* parameter contained a character that was not valid.

**AP\_INVALID\_NODE\_TYPE**

The *node\_type* parameter was not set to a valid value.

**AP\_PU\_CONC\_NOT\_SUPPORTED**

This version of CS/AIX does not support the SNA gateway feature.

**AP\_DLUR\_NOT\_SUPPORTED**

This version of CS/AIX does not support the DLUR feature.

**AP\_INVALID\_REG\_WITH\_NN**

The *reg\_with\_nn* parameter was not set to a valid value.

## DEFINE\_PARTNER\_LU

### AP\_INVALID\_COS\_TABLE\_VERSION

The *cos\_table\_version* parameter was not set to a valid value.

### AP\_INVALID\_SEND\_TERM\_SELF

The *send\_term\_self* parameter was not set to a valid value.

### AP\_INVALID\_DISABLE\_BRANCH\_AWRN

The *disable\_branch\_awareness* parameter was not set to a valid value.

### AP\_INVALID\_DLUR\_SUPPORT

The *dlur\_support* parameter was not set to a valid value.

### AP\_INVALID\_HPR\_SUPPORT

The *hpr\_support* parameter was not set to a valid value.

Appendix B, “Common return codes,” on page 661 lists further secondary return codes associated with AP\_PARAMETER\_CHECK, which are common to all NOF verbs.

## Returned parameters: state check

If the verb does not execute because of a state error, CS/AIX returns the following parameters.

### *primary\_rc*

AP\_STATE\_CHECK

### *secondary\_rc*

#### AP\_NODE\_ALREADY\_STARTED

The target node is active, so you cannot use this verb to modify its configuration. DEFINE\_NODE can be issued only to an inactive node.

Appendix B, “Common return codes,” on page 661 lists further secondary return codes associated with AP\_STATE\_CHECK, which are common to all NOF verbs.

## Returned parameters: other conditions

Appendix B, “Common return codes,” on page 661 lists further combinations of primary and secondary return codes that are common to all NOF verbs.

## DEFINE\_PARTNER\_LU

---

The DEFINE\_PARTNER\_LU verb defines the parameters of a partner LU for LU-LU sessions between a local LU and the partner LU, or modifies an existing partner LU. You cannot change the partner LU alias of an existing partner LU.

There is normally no requirement to define partner LUs, because CS/AIX will set up an implicit definition when the session to the partner LU is established; you should only need to define the LU if you need to enforce non-default values for logical record size, conversation security support, or parallel session support. You may also have an APPC application that uses a partner LU alias when allocating a session, therefore you need to define a partner LU in order to map the alias to a fully-qualified partner LU name.

If the local node or the remote node (where the partner LU is located) is a LEN node, note that you need to define a directory entry for the partner LU to allow CS/AIX to access it. This can be done using either DEFINE\_ADJACENT\_LEN\_NODE or DEFINE\_DIRECTORY\_ENTRY. If both the local and remote nodes are network nodes, or if one is a network node and the other is an end node, the directory entry is not required, because CS/AIX can locate the LU dynamically.

## VCB structure

```
typedef struct define_partner_lu
{
    AP_UINT16      opcode;           /* verb operation code          */
    unsigned char  reserv2;         /* reserved                      */
    unsigned char  format;         /* reserved                      */
    AP_UINT16      primary_rc;     /* primary return code          */
    AP_UINT32      secondary_rc;   /* secondary return code        */
}
```



```

    PLU_CHARS      plu_chars;          /* partner LU characteristics */
} DEFINE_PARTNER_LU;

typedef struct plu_chars
{
    unsigned char  fqplu_name[17];     /* fully qualified partner LU name */
    unsigned char  plu_alias[8];       /* partner LU alias                */
    unsigned char  description[32];    /* resource description             */
    unsigned char  reserv2[16];        /* reserved                          */
    unsigned char  plu_un_name[8];     /* partner LU uninterpreted name    */
    unsigned char  preference;         /* reserved                          */
    AP_UINT16      max_mc_ll_send_size; /* maximum MC send LL size          */
    unsigned char  conv_security_ver;   /* already-verified security        */
                                        /* supported?                        */
    unsigned char  parallel_sess_supp; /* parallel sessions supported?     */
    unsigned char  reserv3[8];         /* reserved                          */
} PLU_CHARS;

```

## Supplied parameters

The application supplies the following parameters:

### **opcode**

AP\_DEFINE\_PARTNER\_LU

### ***plu\_chars.fqplu\_name***

Fully qualified LU name for the partner LU. The name is a 17-byte EBCDIC string, right-padded with EBCDIC spaces. It consists of a network ID of up to 8 A-string characters, an EBCDIC dot (period) character, and a network name of up to 8 A-string characters.

The name must not match the fully-qualified partner LU name of any other partner LU, or the LU name of any local LU.

### ***plu\_chars.plu\_alias***

LU alias of the partner LU. This is an 8-byte ASCII string, using any locally displayable characters, padded on the right with spaces if the name is shorter than 8 bytes.

If the *fqplu\_name* parameter above matches the fully qualified name of an existing partner LU, this parameter must match the partner LU alias in the existing definition. You cannot change the partner LU alias for an existing partner LU, or set up more than one LU alias for the same fully qualified name.

### ***plu\_chars.description***

A null-terminated text string (0-31 characters followed by a null character) describing the partner LU. This string is for information only; it is stored in the node's configuration file and returned on the QUERY\_PARTNER\_LU and QUERY\_PARTNER\_LU\_DEFINITION verbs, but CS/AIX does not make any other use of it.

### ***plu\_chars.plu\_un\_name***

Uninterpreted name of the partner LU (the name of the LU as defined to the remote SSCP). The name is an 8-byte EBCDIC character string.

To use the default uninterpreted name (the same as the network name taken from the *fqplu\_name* parameter above), set this parameter to 8 binary zeros. This parameter is only relevant if the partner LU is on a host and dependent LU 6.2 is used to access it.

### ***plu\_chars.max\_mc\_ll\_send\_size***

The maximum size of logical records that can be sent and received by mapped conversation services at the partner LU. Specify a number in the range 1-32,767, or zero to specify no limit (in this case the maximum is 32,767).

### ***plu\_chars.conv\_security\_ver***

Specifies whether the partner LU is authorized to validate user IDs on behalf of local LUs; that is, whether the partner LU may set the already verified indicator in an Attach request. Possible values are:

#### **AP\_YES**

The partner LU can validate user IDs.

## DEFINE\_PARTNER\_LU

### AP\_NO

The partner LU cannot validate user IDs.

### *plu\_chars.parallel\_sess\_supp*

Specifies whether the partner LU supports parallel sessions. Possible values are:

### AP\_YES

The partner LU supports parallel sessions.

### AP\_NO

The partner LU does not support parallel sessions.

## Returned parameters: successful execution

If the verb executes successfully, CS/AIX returns the following parameters:

### *primary\_rc*

AP\_OK

## Returned parameters: parameter check

If the verb does not execute because of a parameter error, CS/AIX returns the following parameters:

### *primary\_rc*

AP\_PARAMETER\_CHECK

### *secondary\_rc*

Possible values are:

#### AP\_DEF\_PLU\_INVALID\_FQ\_NAME

The *fqplu\_name* parameter contained a character that was not valid.

#### AP\_INVALID\_UNINT\_PLU\_NAME

The *plu\_un\_name* parameter contained a character that was not valid.

Appendix B, “Common return codes,” on page 661 lists further secondary return codes associated with AP\_PARAMETER\_CHECK, which are common to all NOF verbs.

## Returned parameters: state check

If the verb does not execute because of a state error, CS/AIX returns the following parameters.

### *primary\_rc*

AP\_STATE\_CHECK

### *secondary\_rc*

Possible values are:

#### AP\_INVALID\_FQ\_LU\_NAME

The *fqplu\_name* parameter matched the name of an existing local LU.

#### AP\_PLU\_ALIAS\_CANT\_BE\_CHANGED

The *plu\_alias* parameter of an existing partner LU cannot be changed.

#### AP\_PLU\_ALIAS\_ALREADY\_USED

The *plu\_alias* parameter is already used for an existing partner LU with a different LU name.

Appendix B, “Common return codes,” on page 661 lists further secondary return codes associated with AP\_STATE\_CHECK, which are common to all NOF verbs.

## Returned parameters: other conditions

Appendix B, “Common return codes,” on page 661 lists further combinations of primary and secondary return codes that are common to all NOF verbs.

## DEFINE\_PORT

DEFINE\_PORT is used to define a new port or modify an existing one. Before issuing this verb, you must issue the DEFINE\_DLC verb to define the DLC that this port uses.

You can modify an existing port only if it is not started. You cannot change the DLC used by an existing port; the *dlc\_name* specified when modifying an existing port must match the DLC that was specified on the initial definition of the port.

If you are defining a port that will accept incoming calls, see [“Incoming calls” on page 174](#).

### VCB structure

```
typedef struct define_port
{
    AP_UINT16      opcode;           /* verb operation code          */
    unsigned char  reserv2;         /* reserved                     */
    unsigned char  format;         /* reserved                     */
    AP_UINT16      primary_rc;     /* primary return code          */
    AP_UINT32      secondary_rc;   /* secondary return code        */
    unsigned char  port_name[8];   /* name of port                 */
    PORT_DEF_DATA  def_data;       /* port defined data            */
} DEFINE_PORT;
```

```
typedef struct port_def_data
{
    unsigned char  description[32]; /* resource description          */
    unsigned char  initially_active; /* is the port initially active? */
    unsigned char  reserv2[15];    /* reserved                     */
    unsigned char  dlc_name[8];    /* DLC name associated with port */
    unsigned char  port_type;      /* port type                    */
    unsigned char  port_attributes[4]; /* port attributes              */
    unsigned char  implicit_uplink_to_en; /* implicit EN links up or down? */
    unsigned char  implicit_appn_links_len; /* reserved                    */
    unsigned char  reserv3;       /* reserved                     */
    AP_UINT32      port_number;    /* port number                  */
    AP_UINT16      max_rcv_btu_size; /* max receive BTU size        */
    AP_UINT16      tot_link_act_lim; /* total link activation limit  */
    AP_UINT16      inb_link_act_lim; /* inbound link activation limit */
    AP_UINT16      out_link_act_lim; /* outbound link activation limit */
    unsigned char  ls_role;       /* initial link station role    */
    unsigned char  retry_flags;   /* reserved                     */
    AP_UINT16      max_activation_attempts; /* reserved                    */
    AP_UINT16      activation_delay_timer; /* reserved                    */
    unsigned char  mltg_pacing_algorithm; /* reserved                    */
    unsigned char  implicit_tg_sharing_prohibited; /* reserved                    */
    unsigned char  link_spec_data_format; /* reserved                    */
    unsigned char  limit_enable;   /* reserved                     */
    unsigned char  reserv1[6];     /* reserved                     */
    unsigned char  implicit_dspu_template[8]; /* implicit dspu template      */
    AP_UINT16      implicit_ls_limit; /* implicit ls limit            */
    unsigned char  reserv4;       /* reserved                     */
    unsigned char  implicit_dspu_services; /* implicit DSPU support        */
    AP_UINT16      implicit_deact_timer; /* deact timer for implicit Ls  */
    AP_UINT16      act_xid_exchange_limit; /* activation XID exchange limit */
    AP_UINT16      nonact_xid_exchange_limit; /* non-activation XID exchange limit */
    unsigned char  ls_xmit_rcv_cap; /* LS transmit-receive capability */
    unsigned char  max_ifrm_rcvd; /* maximum number of I-frames that */
    /* can be received */
    AP_UINT16      target_pacing_count; /* Target pacing count          */
    AP_UINT16      max_send_btu_size; /* Desired maximum send BTU size */
    LINK_ADDRESS   dlc_data;       /* DLC data                    */
    LINK_ADDRESS   hpr_dlc_data;   /* reserved                    */
    unsigned char  implicit_cp_cp_sess_support; /* implicit links allow */
    /* CP-CP sessions */
    unsigned char  implicit_limited_resource; /* implicit links are */
    /* limited resource */
    unsigned char  implicit_hpr_support; /* Is HPR supported?          */
    unsigned char  implicit_link_lvl_error; /* Send HPR traffic on implicit */
    /* links using link-level error */
    /* recovery? */
    unsigned char  retired1;       /* reserved                     */
    TG_DEFINED_CHARS default_tg_chars; /* default TG chars            */
    unsigned char  discovery_supported; /* reserved                    */
    AP_UINT16      port_spec_data_len; /* length of port specification */
}
```

## DEFINE\_PORT

```

        AP_UINT16      link_spec_data_len;      /* data */
        } PORT_DEF_DATA;                       /* length of link specification */
                                           /* data */

typedef struct link_address
{
    unsigned char      format;                  /* type of link address */
    unsigned char      reserve1;               /* reserved */
    AP_UINT16          length;                  /* length */
    unsigned char      address[135];          /* address */
} LINK_ADDRESS;

typedef struct tg_defined_chars
{
    unsigned char      effect_cap;             /* effective capacity */
    unsigned char      reserve1[5];           /* reserved */
    unsigned char      connect_cost;          /* connection cost */
    unsigned char      byte_cost;             /* byte cost */
    unsigned char      reserve2;              /* reserved */
    unsigned char      security;              /* security */
    unsigned char      prop_delay;            /* propagation delay */
    unsigned char      modem_class;           /* reserved */
    unsigned char      user_def_parm_1;       /* user-defined parameter 1 */
    unsigned char      user_def_parm_2;       /* user-defined parameter 2 */
    unsigned char      user_def_parm_3;       /* user-defined parameter 3 */
} TG_DEFINED_CHARS;
```

### Port-specific data for SDLC:

```
typedef struct sdl_port_spec_data
{
    V0_MUX_INFO        mux_info;               /* Streams config info */
    AP_UINT32          idle_timer;             /* idle timer (in ms) */
    AP_UINT16          idle_timer_retry;      /* idle timer retry */
    AP_UINT16          reserve1;              /* reserved */
    AP_UINT32          np_rcv_timer;          /* non-productive receive timer (in ms) */
    AP_UINT16          np_rcv_timer_retry;    /* non-productive receive timer retry */
    unsigned char      np_rcv_timer_fail;     /* reserved */
    unsigned char      reserve2;              /* reserved */
    AP_UINT32          write_timer;           /* write timer (in ms) */
    AP_UINT16          write_timer_retry;     /* write timer retry */
    AP_UINT16          reserve3;              /* reserved */
    AP_UINT32          link_conn_timer;       /* link connection timer (in ms) */
    AP_UINT16          link_conn_timer_retry; /* link connection timer retry */
    AP_UINT16          reserve4;              /* reserved */
    AP_UINT16          pri_fdplx;             /* reserved */
    AP_UINT16          sec_fdplx;            /* reserved */
    AP_UINT16          use_rej;               /* Can REJ command be used on this port */
    AP_UINT16          port_type;             /* Port type */
    AP_UINT16          max_xid_size;          /* max size of XIDs in MU_SEND_XID */
    AP_UINT16          max_retry_count;       /* max number of times to retransmit */
    AP_UINT16          physical_link;         /* line type of physical link */
    AP_UINT16          stub_spec_data_len;    /* length of next field */
    STUB_SPEC_DATA     stub_spec_data;        /* data specific to HMOD stub */
} SDL_PORT_SPEC_DATA;
```

### Link-specific data for SDLC:

```
typedef struct sdl_link_spec_data
{
    V0_MUX_INFO        mux_info;               /* Streams config info */
    AP_UINT16          reserve8;              /* reserved */
    AP_UINT16          reserve9;              /* reserved */
    AP_UINT32          contact_timer;         /* contact timer (fast poll, in ms) */
    AP_UINT16          contact_timer_retry;   /* contact timer retry */
    AP_UINT16          reserve1;              /* reserved */
    AP_UINT32          contact_timer2;        /* contact timer (slow poll, in ms) */
    AP_UINT16          contact_timer_retry2;  /* contact timer 2 retry */
    AP_UINT16          reserve2;              /* reserved */
    AP_UINT32          disc_timer;            /* disconnect timer (in ms) */
    AP_UINT16          disc_timer_retry;     /* disconnect timer retry */
    AP_UINT16          reserve3;              /* reserved */
    AP_UINT32          nve_poll_timer;        /* negative poll timer (fast poll) */
    AP_UINT16          nve_poll_timer_retry; /* negative poll timer retry */
    AP_UINT16          reserve4;              /* reserved */
    AP_UINT32          nve_poll_timer2;       /* negative poll timer (slow poll) */
}
```

```

AP_UINT16      nve_poll_timer_retry2; /* negative poll timer 2 retry */
AP_UINT16      reserve5;              /* reserved */
AP_UINT32      no_resp_timer;         /* No response timer (T1 timer) */
/* (in ms) */
AP_UINT16      no_resp_timer_retry;   /* No response timer retry */
AP_UINT16      reserve6;              /* reserved */
AP_UINT32      rem_busy_timer;        /* Remote busy timer (in ms) */
AP_UINT16      rem_busy_timer_retry; /* Remote busy timer retry */
unsigned char  re_tx_threshold;       /* I-frame retransmission threshold*/
unsigned char  repoll_threshold;      /* Poll retransmission threshold */
AP_UINT32      rr_timer;              /* RR turnaround timer (in ms) */
unsigned char  group_address;         /* reserved */
unsigned char  poll_frame;            /* Poll frame to use when Primary */
/* and polling secondary */
/* XID, DISC, SNRM, SNRME, TEST */
AP_UINT16      poll_on_iframe;        /* Can LS send poll bit on I-frame */
AP_UINT16      stub_spec_data_len;    /* length of next field */
STUB_SPEC_DATA stub_spec_data;       /* data specific to HMOD stub */
} SDL_LINK_SPEC_DATA;

```

```

typedef struct stub_spec_data
{
AP_INT32      mux_id;                 /* reserved */
unsigned char opt1;                   /* options flag 1 */
unsigned char opt2;                   /* options flag 2 */
unsigned char pad[2];                 /* reserved */
AP_UINT32     linesp;                 /* line speed in bps */
AP_UINT16     rcv_pool_size;          /* initial number of buffers for rcv pool */
AP_UINT16     poll_wait;              /* seconds between polling HMOD for errors*/
AP_UINT16     hmod_data_len;          /* length of dial data string */
unsigned char hmod_data[80];          /* dial data string */
unsigned char x21_sequence[255];     /* X21 selection sequence */
unsigned char x21_retry_count;        /* X21 max call retries */
AP_UINT16     x21_retry_delay;        /* X21 delay between retries */
AP_UINT16     v25_tx_delay;           /* V25 pause before dialling */
unsigned char cdstl;                  /* Wait for RI before DTR */
unsigned char hex_hmod_data;          /* reserved */
unsigned char reserve1[2];            /* reserved */
} STUB_SPEC_DATA;

```

#### Port-specific data for QLLC:

```

typedef struct vql_port_spec_data
{
VO_MUX_INFO   mux_info;               /* streams config info */
unsigned char driver_name[13];        /* reserved */
unsigned char cud_mode;               /* reserved */
AP_UINT16     cud_len;                /* reserved */
unsigned char cud[16];                /* reserved */
unsigned char add_mode;               /* reserved */
AP_UINT16     add_len;                /* reserved */
AP_UINT32     xtras;                 /* reserved */
AP_UINT32     xtra_len;               /* reserved */
} VQL_PORT_SPEC_DATA;

```

#### Link-specific data for QLLC:

```

typedef struct vql_ls_spec_data
{
VO_MUX_INFO   mux_info;               /* streams config info */
AP_UINT16     reserve1;                /* reserved */
AP_UINT16     reserve2;                /* reserved */
unsigned char vc_type;                 /* Virtual Circuit type */
unsigned char req_rev_charge;          /* request reverse charge if */
/* non-zero */
unsigned char loc_packet;              /* loc->rem packet */
/* size 2**locpacket */
unsigned char rem_packet;              /* rem->loc packet */
/* size 2**rempacket */
unsigned char loc_wsize;                /* loc->rem window size */
unsigned char rem_wsize;                /* rem->loc window size */
AP_UINT16     fac_len;                 /* reserved */
unsigned char fac[128];                /* reserved */
AP_UINT16     retry_limit;              /* times to retry send QXID,QSM, */
/* QDISC */
AP_UINT16     retry_timeout;            /* timeout for each of above tries*/
AP_UINT16     idle_timeout;            /* timeout for no Q msgs during */
/* init */
}

```

## DEFINE\_PORT

```
AP_UINT16    pvc_id;           /* PVC logical channel identifier */
AP_UINT16    sn_id_len;       /* reserved */
unsigned char sn_id[4];       /* reserved */
AP_UINT16    cud_len;        /* length of any call user data */
/* to send */
unsigned char cud[128];       /* actual call user data */
AP_UINT32    xtras;          /* reserved */
AP_UINT32    xtra_len;        /* reserved */
unsigned char rx_thrput_class; /* Max Rx speed of calling DTE */
unsigned char tx_thrput_class; /* Max Tx speed of calling DTE */
/* Values for these fields are: */
/* 0 - Default */
/* 0x07 - 1200 */
/* 0x08 - 2400 */
/* 0x09 - 4800 */
/* 0x0a - 9600 */
/* 0x0b - 19200 */
/* 0x0b - 48000 */
unsigned char cugo;          /* Closed User Group (outgoing) */
unsigned char cug;           /* LS used by Closed User Group */
AP_UINT16    cug_index;      /* Index of CUG using this LS */
AP_UINT16    nuid_length;    /* Length of Network User ID */
unsigned char nuid_data[109]; /* Network User ID */
unsigned char reserve3[2];    /* Reserved field */
unsigned char rpoa_count;     /* Count of RPOA codes */
AP_UINT16    rpoa_ids[30];   /* Array of RPOA codes */
} VQL_LS_SPEC_DATA;
```

### Port-specific data for Token Ring, Ethernet:

```
typedef struct gdlc_sap_cfg
{
    V0_MUX_INFO    mux_info;           /* Streams config info */
    AP_UINT16      rem_wsize;          /* reserved */
    unsigned char  local_name[8];      /* Unique name of SAP on network */
} GDLC_SAP_CFG;
```

### Link-specific data for Token Ring, Ethernet:

```
typedef struct gdlc_ls_cfg
{
    V0_MUX_INFO    mux_info;           /* Streams config info */
    AP_UINT16      reserve1;           /* reserved */
    AP_UINT16      reserve2;           /* reserved */
    AP_UINT16      loc_wsize;          /* reserved */
    AP_UINT16      rem_wsize;          /* reserved */
    AP_UINT16      xid_timeout;        /* XID timeout value */
    AP_UINT16      xid_retry_limit;    /* XID retransmission limit */
    AP_UINT16      t1_timeout;        /* T1 timeout value */
    AP_UINT16      t1_retry_limit;     /* I-frame retransmission limit */
    AP_UINT16      ack_time;           /* Acknowledgment timeout value */
    AP_UINT16      inact_time;         /* Inactivity timeout value */
    AP_UINT16      force_time;         /* Force halt time-out value */
    union
    {
        struct
        {
            AP_UINT16    pkt_prt;      /* reserved */
            AP_UINT16    dyna_wnd;     /* Dynamic window increment for */
            /* transmit window */
        } tr;
    } uu;
} GDLC_LS_CFG;
```

### Port-specific data for Enterprise Extender (HPR/IP):

```
typedef struct ipdlc_port_spec_data
{
    V0_MUX_INFO    mux_info;           /* streams information */
    unsigned char  if_name[46];        /* Local interface id or IP address */
} IPDLC_PORT_SPEC_DATA;
```

### Link-specific data for Enterprise Extender (HPR/IP):

```
typedef struct ipdlc_link_spec_data
{
    V0_MUX_INFO    mux_info;           /* streams information */
}
```

```

AP_UINT16    ack_timeout;           /* ACK timer for command frames */
AP_UINT16    max_retry;            /* Retry limit for command frames */
AP_UINT16    liveness_timeout;    /* Liveness timer */
unsigned char short_hold_mode;    /* Run in short-hold mode */
unsigned char remote_hostname[255]; /* Name of remote host to contact */
} IPDLC_LINK_SPEC_DATA;

```

Data for all DLC types:

```

typedef struct v0_mux_info
{
    AP_UINT16    dlc_type;           /* DLC implementation type */
    unsigned char need_vrfy_fixup;  /* reserved */
    unsigned char num_mux_ids;      /* reserved */
    AP_UINT32    card_type;         /* type of adapter card */
    AP_UINT32    adapter_number;    /* DLC adapter number */
    AP_UINT32    oem_data_length;   /* reserved */
    AP_INT32     mux_ids[5];        /* reserved */
} V0_MUX_INFO;

```

For Token Ring or Ethernet, the *address* parameter in the *link\_address* structure is replaced by the following:

```

typedef struct tr_address
{
    unsigned char mac_address[6];    /* reserved */
    unsigned char lsap_address;     /* local SAP address */
} TR_ADDRESS;

```

For Enterprise Extender (HPR/IP), the *address* parameter in the *link\_address* structure is replaced by the following:

```

typedef struct ip_address_info
{
    unsigned char lsap;              /* Local Service Access Point addr */
    unsigned char version;          /* IPv4 or IPv6 */
    unsigned char address[272];     /* IP Address or hostname */
} IP_ADDRESS_INFO;

```

## Supplied parameters

The application supplies the following parameters:

### ***opcode***

AP\_DEFINE\_PORT

### ***port\_name***

Name of port being defined. This is an 8-byte ASCII string, using any locally displayable characters, padded on the right with spaces if the name is shorter than 8 bytes.

### ***def\_data.description***

A null-terminated text string (0-31 characters followed by a null character) describing the port. This string is for information only; it is stored in the node's configuration file and returned on the QUERY\_PORT verb, but CS/AIX does not make any other use of it.

### ***def\_data.initially\_active***

Specifies whether this port is automatically started when the node is started. Possible values are:

#### **AP\_YES**

The port is automatically started when the node is started.

#### **AP\_NO**

The port is automatically started only if an LS that uses it is defined to be initially active; otherwise it must be started manually.

### ***def\_data.dlc\_name***

Name of associated DLC. This is an 8-byte ASCII string, using any locally displayable characters, padded on the right with spaces if the name is shorter than 8 bytes. The specified DLC must have already been defined by a DEFINE\_DLC verb.

## DEFINE\_PORT

### ***def\_data.port\_type***

Type of line used by the port.

For SDLC, the following values are allowed:

#### **AP\_PORT\_SWITCHED**

Switched line.

#### **AP\_PORT\_NONSWITCHED**

Nonswitched line.

For QLLC, this parameter must be set to AP\_PORT\_SWITCHED.

For Token Ring / Ethernet, this parameter must be set to AP\_PORT\_SATF (shared access transport facility).

For Enterprise Extender (HPR/IP), this parameter must be set to AP\_PORT\_SATF (shared access transport facility).

### ***def\_data.port\_attributes***

This is a one-bit parameter that may take the following values:

#### **AP\_NO**

Incoming calls are resolved by CP name.

#### **AP\_RESOLVE\_BY\_LINK\_ADDRESS**

This specifies that an attempt is made to resolve incoming calls by using the link address on CONNECT\_IN before using the CP name (or node ID) carried on the received XID3 to resolve them. This bit is ignored unless the *port\_type* parameter is set to AP\_PORT\_SWITCHED.

### ***def\_data.implicit\_uplink\_to\_en***

This parameter applies only if the local node is a Branch Network Node; it is reserved if the local node is any other type.

If the adjacent node is an end node, this parameter specifies whether implicit link stations off this port are uplink or downlink. This parameter is ignored if there are existing links to the same adjacent node, because in this case the existing links are used to determine the link type. Possible values are:

#### **AP\_YES**

Implicit links to an End Node are uplinks.

#### **AP\_NO**

Implicit links to an End Node are downlinks.

### ***def\_data.port\_number***

The number of the port.

For Enterprise Extender (HPR/IP), this parameter is reserved.

### ***def\_data.max\_rcv\_btu\_size***

Maximum BTU size that can be received. The value includes the length of the TH and RH (total 9 bytes) as well as the RU. Specify a value in the range 265-65535 (265-4105 for SDLC, 265-1496 for Ethernet, 265-17745 for Token Ring).

### ***def\_data.tot\_link\_act\_lim***

Total link activation limit (the maximum number of links that can be active at any time using this port).

For an SDLC port with *port\_type* set to AP\_NONSWITCHED and *ls\_role* set to AP\_LS\_PRI or AP\_LS\_SEC, the range is 1-256 (a value greater than 1 defines a multi-drop primary link or a multi-PU secondary link). For all other SDLC ports, this parameter must be set to 1.

### ***def\_data.inb\_link\_act\_lim***

Inbound link activation limit (the number of links reserved for inbound activation). The sum of *inb\_link\_act\_lim* and *out\_link\_act\_lim* must not exceed *tot\_link\_act\_lim*; the difference between *inb\_link\_act\_lim* and *tot\_link\_act\_lim* defines the maximum number of links that can be activated outbound at any time.



For an SDLC port with *port\_type* set to AP\_NONSWITCHED, this parameter must be zero. If *port\_type* is set to AP\_SWITCHED, then the port must be defined to accept either incoming calls (*inb\_link\_act\_lim* = 1 and *out\_link\_act\_lim* = 0) or outgoing calls (*inb\_link\_act\_lim* = 0 and *out\_link\_act\_lim* = 1).

#### ***def\_data.out\_link\_act\_lim***

Outbound link activation limit (the number of links reserved for outbound activation). The sum of *inb\_link\_act\_lim* and *out\_link\_act\_lim* must not exceed *tot\_link\_act\_lim*; the difference between *out\_link\_act\_lim* and *tot\_link\_act\_lim* defines the maximum number of links that can be activated inbound at any time.

For an SDLC port with *port\_type* set to AP\_NONSWITCHED, this parameter must be equal to *tot\_link\_act\_lim*. If *port\_type* is set to AP\_SWITCHED, then the port must be defined to accept either incoming calls (*inb\_link\_act\_lim* = 1 and *out\_link\_act\_lim* = 0) or outgoing calls (*inb\_link\_act\_lim* = 0 and *out\_link\_act\_lim* = 1).

#### ***def\_data.ls\_role***

Link station role.

For SDLC or QLLC, the following values are allowed:

##### **AP\_LS\_PRI**

Primary

##### **AP\_LS\_SEC**

Secondary

##### **AP\_LS\_NEG**

Negotiable

For Token Ring / Ethernet / Enterprise Extender (HPR/IP), this must be set to AP\_LS\_NEG.

#### ***def\_data.implicit\_dspu\_template***

Specifies the DSPU template, defined on the DEFINE\_DSPU\_TEMPLATE verb. This template is used for definitions if the local node is to provide SNA gateway for an implicit link activated on this port. If the template specified does not exist or is already at its instance limit when the link is activated, activation will fail. This template name is an 8-byte string in a locally displayable character set.

If the *implicit\_dspu\_services* parameter is not set to AP\_PU\_CONCENTRATION, the *implicit\_dspu\_template* parameter is reserved.

#### ***def\_data.implicit\_ls\_limit***

Specifies the maximum number of implicit link stations that can be active on this port simultaneously, including dynamic links and links activated for Discovery. Specify a value in the range 1-65,534 or specify 0 (zero) to indicate no limit. A value of AP\_NO\_IMPLICIT\_LINKS indicates that no implicit links are allowed.

#### ***def\_data.implicit\_dspu\_services***

Specifies the services that the local node will provide to the downstream PU across implicit links activated on this port. Possible values are:

##### **AP\_DLUR**

Local node will provide DLUR services for the downstream PU (using the default DLUS configured through the DEFINE\_DLUR\_DEFAULTS verb).

##### **AP\_PU\_CONCENTRATION**

Local node will provide SNA gateway for the downstream PU. It will also put in place definitions as specified by the DSPU template specified for the parameter *implicit\_dspu\_template*.

##### **AP\_NONE**

Local node will provide no services for this downstream PU.

#### ***def\_data.implicit\_deact\_timer***

If *implicit\_hpr\_support* is set to AP\_YES and *implicit\_limited\_resource* is set to AP\_NO\_SESSIONS, an HPR-capable implicit link is automatically deactivated if no data flows on it for the time specified by this parameter and no sessions are using the link.

## DEFINE\_PORT

Implicit limited resource link deactivation timer (in seconds). If *implicit\_limited\_resource* is set to AP\_INACTIVITY, an implicit link using this port will be deactivated if no data flows on it for the time specified by this parameter.

The minimum value is 5; values in the range 1-4 will be interpreted as 5. Zero indicates no timeout (the link is not deactivated, as though *implicit\_limited\_resource* were set to AP\_NO). This parameter is reserved if *implicit\_limited\_resource* is set to any value other than AP\_INACTIVITY.

### ***def\_data.act\_xid\_exchange\_limit***

Activation XID exchange limit.

### ***def\_data.nonact\_xid\_exchange\_limit***

Non-activation XID exchange limit.

### ***def\_data.ls\_xmit\_rcv\_cap***

Specifies the link station transmit/receive capability. Possible values are:

#### **AP\_LS\_TWS**

Two-way simultaneous

#### **AP\_LS\_TWA**

Two-way alternating

For Enterprise Extender (HPR/IP), this parameter must be set to AP\_LS\_TWS.

### ***def\_data.max\_ifrm\_rcvd***

Maximum number of I-frames that can be received by the local link stations before an acknowledgment is sent. Range: 1-127.

### ***def\_data.target\_pacing\_count***

Numeric value between 1 and 32,767 inclusive indicating the desired pacing window size. (The current version of CS/AIX does not make use of this value.)

### ***def\_data.max\_send\_btu\_size***

Maximum BTU size that can be sent from this port. This value is used to negotiate the maximum BTU size that a pair of link stations can use to communicate with each other. The value includes the length of the TH and RH (total 9 bytes) as well as the RU. Specify a value in the range 265-65535 (265-4105 for SDLC, 265-1496 for Ethernet, 265-17745 for Token Ring).

### ***def\_data.dlc\_data.format***

The type of link address specified for this port. Possible values:

#### **AP\_IP\_ADDRESS\_INFO**

IP address. Specify this value for an Enterprise Extender (HPR/IP) port.

#### **AP\_UNSPECIFIED**

Unspecified address format. Specify this value for any port type other than Enterprise Extender (HPR/IP).

### ***def\_data.dlc\_data.length***

Length of the port address (in the following parameter).

### ***def\_data.dlc\_data.address***

Port address.

For SDLC, this is a 1-byte address. If *ls\_role* is set to AP\_LS\_SEC, or if *ls\_role* is set to AP\_LS\_NEG and the local station becomes secondary after LS role negotiation, this address is used in the response to an incoming call. If the local station is primary, or if the port is used only for outgoing calls, this parameter is reserved.

For QLLC, this is a string of 1-14 bytes, specifying the local X.25 DTE address of the port. This address must match the address configured in your X.25 driver for this network.

**Note:** If no address is specified on a QLLC port, an outgoing call request generated by CS/AIX will not contain the X.25 calling address. Some hosts require this address as a security measure on incoming calls, and may not accept the connection without it.

***def\_data.dlc\_data.tr\_address.lsap\_address***

For Token Ring or Ethernet: Local SAP address of the port. Specify a multiple of 0x02 in the range 0x04-0xEC.

(The first parameter in the address structure normally contains the MAC address, but this value is used only on the LS and is reserved on the port.)

***def\_data.dlc\_data.ip\_address\_info.lsap***

For Enterprise Extender: Local SAP address of the port. Specify a multiple of 0x04 in the range 0x04-0xEC. The usual value is 0x04, but VTAM may use 0x08 in some circumstances.

If you need to use two or more ports with different LSAP addresses on the same TCP/IP interface, you will need to create two or more Enterprise Extender DLCs, and then create a separate Enterprise Extender port for each DLC with the same *if\_name* but a different LSAP address.

***def\_data.dlc\_data.ip\_address\_info.version***

For Enterprise Extender: Specifies whether the following field represents an IPv4 or IPv6 address. All link stations that use the port must use the same type of address. You cannot change this parameter if one or more link stations already use this port. Possible values:

**IP\_VERSION\_4\_HOSTNAME**

The *address* field specifies an IPv4 address, or a hostname or alias that resolves to an IPv4 address.

**IP\_VERSION\_6\_HOSTNAME**

The *address* field specifies an IPv6 address, or a hostname or alias that resolves to an IPv6 address.

***def\_data.dlc\_data.ip\_address\_info.address***

For Enterprise Extender: IP address of the port. This can be any of the following.

- An IPv4 dotted-decimal address (such as 193.1.11.100).
- An IPv6 colon-hexadecimal address (such as 2001:0db8:0000:0000:0000:0000:1428:57ab or 2001:db8::1428:57ab).
- A name (such as newbox.this.co.uk).
- An alias (such as newbox).

***def\_data.implicit\_cp\_cp\_sess\_support***

Specifies whether CP-CP sessions are permitted for implicit link stations using this port. Possible values are:

**AP\_YES**

CP-CP sessions are permitted for implicit LSs.

**AP\_NO**

CP-CP sessions are not permitted for implicit LSs.

***def\_data.implicit\_limited\_resource***

Specifies whether implicit link stations off this port should be defined as limited resources. Possible values are:

**AP\_NO**

Implicit links are not limited resources, and will not be deactivated automatically.

**AP\_NO\_SESSIONS**

Implicit links are limited resources, and will be deactivated automatically when no active sessions are using them.

**AP\_INACTIVITY**

Implicit links are limited resources, and will be deactivated automatically when no active sessions are using them or when no data has flowed for the time period specified by the *implicit\_deact\_timer* field.

- If no SSCP-PU session is active across the link, the node deactivates the link immediately.

## DEFINE\_PORT

- If an SSCP-PU session is active but no traffic has flowed for the specified time period, the node sends REQDISCONT(normal) to the host. The host is then responsible for deactivating all LUs and the PU, at which time the local node will deactivate the link. However, the host may not deactivate LUs with active PLU-SLU sessions; in this case, the link remains active until all these sessions are deactivated (for example by the user logging out). This behavior can be changed by using options in the *ptf* field of the DEFINE\_NODE verb.

### ***def\_data.implicit\_hpr\_support***

Specifies whether High Performance Routing (HPR) is supported on implicit links. Possible values are:

#### **AP\_YES**

HPR is supported on implicit links.

#### **AP\_NO**

HPR is not supported on implicit links.

For Enterprise Extender (HPR/IP), this parameter must be set to AP\_YES.

### ***def\_data.implicit\_link\_lvl\_error***

For SDLC, Enterprise Extender (HPR/IP), this parameter is reserved.

Specifies whether HPR traffic should be sent on implicit links using link-level error recovery (AP\_YES or AP\_NO). The parameter is reserved if *implicit\_hpr\_support* is set to AP\_NO.

### ***def\_data.default\_tg\_chars***

Default TG characteristics. These are used for implicit link stations using this port, and as the default TG characteristics for defined link stations that do not have TG characteristics explicitly defined. The TG characteristics parameters are ignored if the LS is to a downstream PU.

For details of these parameters, see [“DEFINE\\_LS” on page 100](#).

### ***def\_data.port\_spec\_data\_len***

Length of port-specific data. The data should be concatenated to the basic VCB structure.

### ***def\_data.link\_spec\_data\_len***

Length of link-specific data. The link-specific data should be concatenated immediately following the port-specific data.

For details of these parameters, see [“DEFINE\\_LS” on page 100](#); the values specified on DEFINE\_PORT are used as defaults for processing incoming calls (when the LS name is not initially known).

For SDLC, the parameters in the *stub\_spec\_data* structure within this structure are reserved.

For QLLC, the parameters *vc\_type*, *loc\_packet*, *rem\_packet*, *rem\_wsize*, *pvc\_id*, *cud\_len*, and *cud* are reserved for DEFINE\_PORT; they are used only for DEFINE\_LS.

Port-specific data for SDLC:

### ***mux\_info.dlc\_type***

Type of the DLC. Set this to AP\_IMPL\_SDLC\_SL

### ***idle\_timer***

Timer used to detect a completely inactive line. The line is considered idle when nothing (not even frame data that is not valid) has been received in this time. The timer is specified in milliseconds.

### ***idle\_timer\_retry***

Number of times to rerun the idle timer before failure. This is used in conjunction with *idle\_timer* to provide the overall idle timeout period. This should be longer than either the nonproductive receive timer or the contact and disconnect timers.

A value of 0xFFFF indicates an unlimited retry count. A value of 0x0001 indicates that an outage should be generated after the first timer expiry.

### ***np\_rcv\_timer***

For SDLC secondary, the nonproductive receive timeout corresponds to the time allowed for receipt of a valid frame from the primary. This is usually set in conjunction with the retry limit to give a long timeout before outage (such as 60). The timer is specified in milliseconds.

***np\_rcv\_timer\_retry***

The nonproductive receive retry limit is used in conjunction with the timeout value to provide the overall time before an outage message is issued.

A value of 0xFFFF indicates an unlimited retry count. A value of 0x0001 indicates that an outage should be generated after the first timer expiry.

***write\_timer***

The write timer is the maximum time allowed to transmit a complete frame.

This parameter is usually set in conjunction with the value of the *write\_timer\_retry* parameter to give a long timeout of about 30 seconds before the port is assumed to have failed. The timer is specified in milliseconds.

***write\_timer\_retry***

The write timer retry limit is used in conjunction with the value of the *write\_timer* parameter to provide the overall time before the port is assumed to have failed.

A value of 0xFFFF indicates an unlimited retry count. A value of 0x0001 indicates that an outage should be generated after the first timer expiry.

***link\_conn\_timer***

The link connection timeout together with the retry limit corresponds to the time interval after which CS/AIX fails an attempt to activate an LS because it has not detected that DSR has been raised. The timer is specified in milliseconds.

***link\_conn\_timer\_retry***

The link connection retry limit specifies the number of times to test for link connection before failing an attempt to activate an LS.

A value of 0xFFFF indicates an unlimited retry count. A value of 0x0001 indicates that an outage should be generated after the first timer expiry.

***use\_rej***

Specifies whether CS/AIX can send a REJ frame on receiving an I-frame with a sequence number that is not valid on this port. (CS/AIX always accepts a REJ frame, regardless of the setting of this parameter.) Possible values are:

**AP\_YES**

CS/AIX can send a REJ frame.

**AP\_NO**

CS/AIX cannot send a REJ frame; instead, it requests retransmission of frames through RR, RNR or I-frames.

Use of REJ is only beneficial when full duplex protocol operation is being used. Some SDLC stations may not recognize the REJ command; to connect to them, the value AP\_NO must be set.

***port\_type***

Type of the port.

If *def\_data.port\_type* above is AP\_NONSWITCHED, set this parameter to AP\_PORT\_LEASED.

For a switched line (*def\_data.port\_type* is AP\_SWITCHED):

- If the port is used for outgoing calls (*inb\_link\_act\_lim* is zero), set this parameter to AP\_PORT\_SW\_DIAL (Dial-out capabilities).
- If the port is used for incoming calls (*out\_link\_act\_lim* is zero), set this parameter to AP\_PORT\_SW\_ANSWER (Answer capabilities).

If the switched line's dial-out or answer capabilities are manual, not automatic, combine the value above (using a logical OR) with AP\_PORT\_SW\_MAN.

***max\_xid\_size***

The maximum size of an XID that will be sent or received on this link. This field is present to help minimize buffer usage. A safe absolute maximum is 256 bytes.

## DEFINE\_PORT

### ***max\_retry\_count***

The maximum number of times that a frame or group of frames may be retransmitted on this port before a problem is diagnosed. Usually set to about 5.

### ***physical\_link***

The line type of the SDLC physical link. Possible values are:

- SDLC\_PL\_V25V .25
- SDLC\_PL\_V35V .35
- SDLC\_PL\_X21X .21
- SDLC\_PL\_SMART\_MODEM Smart modem
- SDLC\_PL\_422A EIA422-A
- SDLC\_PL\_232D RS232
- SDLC\_PL\_V35V .35

### ***stub\_spec\_data\_len***

Length of the Stub specific data that follows. Set this to size of (STUB\_SPEC\_DATA).

### ***stub\_spec\_data.opt1***

HMOD port options flag 1. Set the appropriate bits of this field as follows (bit 7 is the most significant bit):

#### ***bit 7***

4-wire connection (2 wire connection if not set).

#### ***bit 6***

Use NRZI (NRZ if not set).

#### ***bit 5***

Reserved (must be set to 0).

#### ***bit 4***

Reserved (must be set to 0).

#### ***bit 3***

Internal line speed clocking (external if not set). This option may be ignored if the underlying SDLC hardware supports only external clocking.

#### ***bit 2***

Reserved (must be set to 0).

#### ***bits 1, 0***

Reserved (must be set to 0).

### ***stub\_spec\_data.opt2***

HMOD port options flag 2. Set the appropriate bits of this field as follows (bit 7 is the most significant bit):

#### ***bit 7***

Use DSRS (do not use if not set)

#### ***bit 6***

Select Standby On (Select Standby Off if not set)

#### ***bit 5***

Monitor DCD (do not monitor if not set)

#### ***bit 4***

Stream flags on the line (do not stream if not set)

#### ***bits 3-0***

Reserved

### ***stub\_spec\_data.linesp***

The line speed for the line used on this port. For example, 2400 (0x00000960) for a 2400 baud line. Valid values are in the range 600-38400 baud.

The exact meaning of this parameter depends on the value set on the *physical\_link* parameter.

- If *physical\_link* is set to SDLC\_PL\_X21, then the *stub\_spec\_data.linesp* parameter is ignored.
- If *physical\_link* is set to SDLC\_PL\_V25 or SDLC\_PL\_SMART\_MODEM, then the value of the *stub\_spec\_data.linesp* parameter is the speed at which the dial string is sent to the modem.
- If *physical\_link* is set to any other value, then the value of the *stub\_spec\_data.linesp* parameter is the speed of data transfer. This value is valid only if external clocking is specified.

***stub\_spec\_data.rcv\_pool\_size***

The initial number of buffers reserved for receiving data on the port. Set this to the value 4.

***stub\_spec\_data.poll\_wait***

The number of seconds for which the port waits between successive polls of the line for errors or for raising of DSR. A suitable value is 1 second. Increase this value for better throughput if there is only small likelihood of line errors and the line is leased.

***stub\_spec\_data.hmod\_data\_len***

Length of the dial data string that follows (in the *hmod\_data* parameter). If no dial data is specified, set this parameter to zero.

***stub\_spec\_data.hmod\_data***

Dial data for incoming calls. (The dial string used to initiate outgoing calls is specified in the LS definition.) This parameter applies only to switched links; it is reserved if the port is defined to be nonswitched.

This is an ASCII string, specifying the dial string that must be passed to the modem to instruct it to respond to incoming calls.

The dial data may need to contain non-printable control characters; for example, it may have to be terminated with a carriage return, equivalent to pressing the Enter key. In this case, include the hexadecimal value of the control character in the string (for example, 0x0D for a carriage return). For details of the hexadecimal values you can use to represent control characters, see [“Modem control characters”](#) on page 126.

Support for dial data depends on the SDLC adapter and modem that you are using; if they do not support dial data, set this parameter to a null string.

***stub\_spec\_data.x21\_sequence***

X21 selection sequence to identify the remote link station. This parameter is only valid if *physical\_link* is set to SDLC\_PL\_X21. This string is limited to digits 0-9 and characters \* (asterisk), + (plus), - (hyphen), . (period) and / (slash). The string must end with + (plus sign). If the string is less than 255 characters long, then it must be null-terminated.

***stub\_spec\_data.x21\_retry\_count***

Number of times that an unsuccessful X21 call may be retried before it is abandoned. This parameter is only valid if *physical\_link* is set to SDLC\_PL\_X21. Valid values are in the range 0-15.

***stub\_spec\_data.x21\_retry\_delay***

Delay, in tenths of a second, before retrying an unsuccessful X21 call. This parameter is only valid if *physical\_link* is set to SDLC\_PL\_X21. Valid values are in the range 0-1200.

***stub\_spec\_data.v25\_tx\_delay***

Amount of time, in tenths of a second, that elapses between sending the DTR (data terminal ready) signal and transmitting a dial string to the modem. This parameter is only valid if *physical\_link* is set to SDLC\_PL\_V25. Valid values are in the range 0-600, which is equal to 0.1 seconds to 1 minute. A value of 0 is treated as 0.1 seconds.

***stub\_spec\_data.cdctl***

Connect Data Set to Line (CDSTL) indicates that Data Terminal Ready (DTR) should not be enabled until after Ring Indicate (RI) has occurred. This parameter is only valid if *physical\_link* is set to SDLC\_PL\_X21. Possible values are:

**AP\_YES**

Do not enable DTR until RI has been signaled.

## DEFINE\_PORT

### **AP\_NO**

Enable DTR without waiting for RI.

Port-specific data for QLLC:

### ***mux\_info.dlc\_type***

Type of the DLC. Set this to AP\_IMPL\_NLI\_QLLC.

Port-specific data for Token Ring or Ethernet:

### ***gdlc\_sap\_cfg.mux\_info.dlc\_type***

Type of the DLC. Possible values are:

### **AP\_IMPL\_TR\_GDLC**

Token Ring

### **AP\_IMPL\_ETHER\_GDLC**

Ethernet

### ***gdlc\_sap\_cfg.max\_ifrm\_rcv***

Maximum number of I-frames that can be received by the local link stations before an acknowledgment is sent. Range: 1-127; this value should match the value specified for *max\_ifrm\_rcvd* earlier in the *port\_def\_data* structure.

### ***gdlc\_sap\_cfg.local\_name***

Unique name to identify the service access point (SAP) on the network. If no local name is specified (indicated by using all spaces), then the SAP cannot be contacted using discovery. This is a type-A EBCDIC character string, padded on the right with EBCDIC spaces if it is less than 8 characters.

Port-specific data for Enterprise Extender (HPR/IP):

### ***mux\_info.dlc\_type***

Type of the DLC. Set this to AP\_IP.

### ***if\_name***

Identifier for the local network adapter card to be used for the IP link, if you have access to multiple IP networks. If you have access to only one IP network, you can leave this field set to binary zeros.

If you need to specify the interface, you can use any of the following.

- An interface identifier (such as eth0 or en0).
- An IPv4 dotted-decimal address (such as 193.1.11.100).
- An IPv6 colon-hexadecimal address (such as 2001:0db8:0000:0000:0000:0000:1428:57ab or 2001:db8::1428:57ab).

To determine the interface identifier, run the command `ipconfig - a` on the server where the card is installed. This lists the interface identifiers and their associated IP addresses.

## Returned parameters: successful execution

If the verb executes successfully, CS/AIX returns the following parameters:

### ***primary\_rc***

AP\_OK

## Returned parameters: parameter check

If the verb does not execute because of a parameter error, CS/AIX returns the following parameters:

### ***primary\_rc***

AP\_PARAMETER\_CHECK

### ***secondary\_rc***

Possible values are:

### **AP\_INVALID\_PORT\_NAME**

The *port\_name* parameter was not valid.



**AP\_INVALID\_DLC\_NAME**

The specified *dlc\_name* did not match any defined DLC.

**AP\_INVALID\_PORT\_TYPE**

The *port\_type* parameter was not set to a valid value.

**AP\_INVALID\_BTU\_SIZE**

The *max\_rcv\_btu\_size* parameter was not set to a valid value.

**AP\_INVALID\_LS\_ROLE**

The *ls\_role* parameter was not set to a valid value.

**AP\_INVALID\_LINK\_ACTIVE\_LIMIT**

One of the activation limit parameters was not set to a valid value.

**AP\_INVALID\_MAX\_IFRM\_RCVD**

The *max\_ifrm\_rcvd* parameter was not set to a valid value.

**AP\_INVALID\_LS\_ROLE**

The *ls\_role* parameter was not set to a valid value.

**AP\_INVALID\_DSPU\_SERVICES**

The *implicit\_dspu\_services* parameter was not set to a valid value.

**AP\_PU\_CONC\_NOT\_SUPPORTED**

The *implicit\_dspu\_services* parameter was set to a reserved value.

**AP\_INVALID\_TEMPLATE\_NAME**

The DSPU template specified on the *implicit\_dspu\_template* parameter was not valid.

**AP\_INVALID\_IP\_VERSION**

The *version* parameter was changed on an existing port used by one or more link stations. You cannot change this parameter if the port has any link stations associated with it.

**AP\_UNKNOWN\_IP\_HOST**

The string specified for the *remote\_hostname* parameter could not be resolved to a valid IP address.

**AP\_INVALID\_SHARING\_PROHIBITED**

A reserved parameter was set to a nonzero value.

**AP\_INVALID\_LINK\_SPEC\_FORMAT**

A reserved parameter was set to a nonzero value.

**AP\_INVALID\_IMPLICIT\_UPLINK**

The *implicit\_uplink\_to\_en* parameter was not set to a valid value.

Appendix B, “Common return codes,” on page 661 lists further secondary return codes associated with `AP_PARAMETER_CHECK`, which are common to all NOF verbs.

## Returned parameters: state check

If the verb does not execute because of a state error, CS/AIX returns the following parameters.

***primary\_rc***

`AP_STATE_CHECK`

***secondary\_rc***

Possible values are:

**AP\_PORT\_ACTIVE**

The specified port cannot be modified because it is currently active.

**AP\_DUPLICATE\_PORT\_NUMBER**

A port with the specified *port\_number* has already been defined.

Appendix B, “Common return codes,” on page 661 lists further secondary return codes associated with `AP_STATE_CHECK`, which are common to all NOF verbs.

## Returned parameters: other conditions

Appendix B, “Common return codes,” on page 661 lists further combinations of primary and secondary return codes that are common to all NOF verbs.

## Incoming calls

If you are configuring a port that will accept incoming calls (as defined by the *tot\_link\_act\_lim*, *inb\_link\_act\_lim*, and *out\_link\_act\_lim* parameters), there is generally no need to define an LS to be used for these calls, because CS/AIX will define one dynamically when the incoming call is received. However, if the incoming calls are from a host computer that supports dependent LUs or from a downstream computer using SNA gateway, you need to define an LS explicitly, because the LS definition includes the name of the PU associated with the dependent LUs or the name of the downstream PU.

When an incoming call arrives at the port, CS/AIX checks the address specified on the call against the addresses specified for LSs defined on the port (if any), to determine if an LS has already been defined for the call. If the address does not match, an LS is defined dynamically. To ensure that the explicit LS definition (including the required PU name) is used, ensure that the address defined for this LS matches the address that will be supplied by the host or the downstream computer on the incoming call. For Token Ring / Ethernet, both the MAC and SAP addresses must match in order to select the correct LS.

## DEFINE\_RCF\_ACCESS

DEFINE\_RCF\_ACCESS specifies access to the CS/AIX Remote Command Facility (RCF): the user ID used to run UNIX Command Facility (UCF) commands, and the restrictions on which administration commands can be issued using the Service Point Command Facility (SPCF). For more information about SPCF and UCF, see the *IBM Communications Server for Data Center Deployment on AIX Administration Guide*. You can use this verb to permit access to both SPCF and UCF, or to only one of them.

This verb must be issued to the domain configuration file; it can be used to specify the RCF access for the first time, or to modify an existing definition. CS/AIX acts on these parameters during node startup; if these parameters are changed while a node is running, the changes do not take effect on the server where the node is running until the node is stopped and restarted.

## VCB structure

```
typedef struct define_rcf_access
{
    AP_UINT16      opcode;           /* Verb operation code          */
    unsigned char  reserv2;         /* reserved                     */
    unsigned char  format;         /* reserved                     */
    AP_UINT16      primary_rc;     /* primary return code         */
    AP_UINT32      secondary_rc;   /* secondary return code       */
    unsigned char  ucf_username[32]; /* UCF username                */
    AP_UINT32      spcf_permissions; /* SPCF permissions           */
    unsigned char  reserv3[8];     /* Reserved                    */
} DEFINE_RCF_ACCESS;
```

## Supplied parameters

The application supplies the following parameters:

### **opcode**

AP\_DEFINE\_RCF\_ACCESS

### **ucf\_username**

Specifies the AIX user name of the UCF user. This parameter is a null-terminated ASCII string. Do not specify the name *root*, because CS/AIX does not allow UCF commands to be run as *root* for security reasons.

All UCF commands will be run using this user's user ID, with the default shell, default group ID, and access permissions that are defined on the AIX system for this user.

To prohibit access to UCF, set this parameter to a null string.

### ***spcf\_permissions***

Specifies the types of CS/AIX verbs that can be accessed using SPCF. Set this to AP\_NONE to prevent access to SPCF, or to one or more of the following values (combined using a logical OR):

#### **AP\_ALLOW\_QUERY\_LOCAL**

QUERY\_\* verbs are permitted.

#### **AP\_ALLOW\_DEFINE\_LOCAL**

DEFINE\_\*, SET\_\*, DELETE\_\*, ADD\_\*, and REMOVE\_\* verbs, and also INIT\_NODE, are permitted.

#### **AP\_ALLOW\_ACTION\_LOCAL**

"Action" verbs are permitted: START\_\*, STOP\_\*, ACTIVATE\_\*, DEACTIVATE\_\*, and also APING, INITIALIZE\_SESSION\_LIMIT, CHANGE\_SESSION\_LIMIT, and RESET\_SESSION\_LIMIT.

#### **AP\_ALLOW\_QUERY\_REMOTE**

The QUERY\_\* verbs are allowed to be directed at any node in the domain.

#### **AP\_ALLOW\_DEFINE\_REMOTE**

The DEFINE\_\*, SET\_\*, DELETE\_\*, ADD\_\*, REMOVE\_\*, and INIT\_NODE verbs are allowed to be directed at any node in the domain.

#### **AP\_ALLOW\_ACTION\_REMOTE**

The START\_\*, STOP\_\*, ACTIVATE\_\*, DEACTIVATE\_\*, APING, INITIALIZE\_SESSION\_LIMIT, CHANGE\_SESSION\_LIMIT, and RESET\_SESSION\_LIMIT verbs are allowed to be directed at any node in the domain.

## **Returned parameters: successful execution**

If the verb executes successfully, CS/AIX returns the following parameters:

### ***primary\_rc***

AP\_OK

## **Returned parameters: parameter check**

If the verb does not execute because of a parameter error, CS/AIX returns the following parameters:

### ***primary\_rc***

AP\_PARAMETER\_CHECK

### ***secondary\_rc***

Possible values are:

#### **AP\_UCF\_USER\_CANNOT\_BE\_ROOT**

The *ucf\_username* parameter specified the name `root`, which is not allowed.

#### **AP\_INVALID\_SPCF\_SECURITY**

The *spcf\_permissions* parameter was not set to a valid value.

Appendix B, “Common return codes,” on page 661 lists further secondary return codes associated with AP\_PARAMETER\_CHECK, which are common to all NOF verbs.

## **Returned parameters: other conditions**

Appendix B, “Common return codes,” on page 661 lists further combinations of primary and secondary return codes that are common to all NOF verbs.

## **DEFINE\_RTP\_TUNING**

DEFINE\_RTP\_TUNING specifies parameters to be used when setting up RTP connections. After you issue this verb, the parameters you specify will be used for all future RTP connections until you modify them by issuing a new DEFINE\_RTP\_TUNING verb.

## VCB structure

```
typedef struct define_rtp_tuning
{
    AP_UINT16      opcode;           /* verb operation code          */
    unsigned char  reserv2;         /* reserved                     */
    unsigned char  format;         /* reserved                     */
    AP_UINT16      primary_rc;     /* primary return code         */
    AP_UINT32      secondary_rc;   /* secondary return code       */
    unsigned char  path_switch_attempts; /* number of path switch attempts */
    unsigned char  short_req_retry_limit; /* short request timer retry limit */
    AP_UINT16      path_switch_times[4]; /* path switch times          */
    AP_UINT32      refifo_cap;     /* maximum for refifo timer    */
    AP_UINT32      srt_cap;       /* maximum for short request timer */
    AP_UINT16      path_switch_delay; /* minimum delay before path switch */
    unsigned char  reserved[78];   /* reserved                    */
} DEFINE_RTP_TUNING;
```

## Supplied parameters

The application supplies the following parameters:

### ***opcode***

AP\_DEFINE\_RTP\_TUNING

### ***path\_switch\_attempts***

Number of path switch attempts to set on new RTP connections. Specify a value in the range 1-255. If you specify 0(zero), CS/AIX uses the default value of 6.

### ***short\_req\_retry\_limit***

Number of times a Status Request is sent before CS/AIX determines that an RTP connection is disconnected and starts Path Switch processing. Specify a value in the range 1-255. If you specify 0(zero), CS/AIX uses the default value of 6.

### ***path\_switch\_times***

Length of time in seconds for which CS/AIX attempts to path switch a disconnected RTP connection. This parameter is specified as four separate time limits for each of the valid transmission priorities in order: AP\_LOW, AP\_MEDIUM, AP\_HIGH, and AP\_NETWORK. Each of these must be in the range 1-65535. The value you specify for each transmission priority must not exceed the value for any lower transmission priority.

If you specify 0(zero) for any of these values, CS/AIX uses the corresponding default value as follows:

- 480 seconds (8 minutes) for AP\_LOW
- 240 seconds (4 minutes) for AP\_MEDIUM
- 120 seconds (2 minutes) for AP\_HIGH
- 60 seconds (1 minute) for AP\_NETWORK

### ***refifo\_cap***

The RTP protocol uses a timer called the Re-FIFO Timer. The value of this timer is calculated as part of the protocol, but this parameter specifies a maximum value in milliseconds beyond which the timer cannot increase. In some situations, setting this maximum value can improve performance. Setting a value of 0 (zero) means that the timer is not limited and can take any value calculated by the protocol.

The default value for this parameter is 4000 milliseconds, with a minimum value of 5 milliseconds. If you specify a value in the range 1-4, the value of 5 will be used.

### ***srt\_cap***

The RTP protocol uses a timer called the Short Request Timer. The value of this timer is calculated as part of the protocol, but this parameter specifies a maximum value in milliseconds beyond which the timer cannot increase. In some situations, setting this maximum value can improve performance. Setting a value of 0 (zero) means that the timer is not limited and can take any value calculated by the protocol.

The default value for this parameter is 8000 milliseconds, with a minimum value of 5 milliseconds. If you specify a value in the range 1-4, the value of 5 will be used.

***path\_switch\_delay***

Minimum delay in seconds before a path switch occurs. Specifying a delay avoids unnecessary path switch attempts caused by transient delays in network traffic, in particular when there is no other route available.

Specify a value in the range 0-65535. The default value is zero, indicating that a path switch attempt can occur as soon as the protocol indicates it is required.

**Returned parameters: successful execution**

If the verb executes successfully, CS/AIX returns the following parameters:

***primary\_rc***

AP\_OK

**Returned parameters: parameter check**

If the verb does not execute because of a parameter error, CS/AIX returns the following parameters:

***primary\_rc***

AP\_PARAMETER\_CHECK

***secondary\_rc***

Possible values are:

**AP\_INVALID\_PATH\_SWITCH\_TIMES**

The *path\_switch\_times* parameter was not valid; for example, you may have specified a value for one transmission priority that exceeds the value specified for a lower transmission priority.

Appendix B, “Common return codes,” on page 661 lists further secondary return codes associated with AP\_PARAMETER\_CHECK, which are common to all NOF verbs.

**Returned parameters: other conditions**

Appendix B, “Common return codes,” on page 661 lists further combinations of primary and secondary return codes that are common to all NOF verbs.

**DEFINE\_SECURITY\_ACCESS\_LIST**

DEFINE\_SECURITY\_ACCESS\_LIST defines a list of users who can access a particular local LU or invocable TP, so that access to that LU or TP is restricted to the named users. It can also be used to add user names to an existing security access list. The user names in the list are either AIX login IDs or user IDs defined using the DEFINE\_USERID\_PASSWORD verb.

If you want to allow access to a local LU using AIX login IDs as the user names, you must disable password substitution for the local LU. However, you should be aware that this involves sending and receiving passwords in clear text (which may represent a security risk). For information on disabling password substitution, see “DEFINE\_LOCAL\_LU” on page 96.

To restrict access for a particular local LU or invocable TP, you need to do the following.

1. Ensure that each authorized user of the LU or TP is defined, either as an AIX login ID on the computer where the LU or TP runs, or as a user ID specified using the DEFINE\_USERID\_PASSWORD verb.
2. Use the DEFINE\_SECURITY\_ACCESS\_LIST verb to define a security access list containing all of these user IDs.
3. Specify the name of this security access list on the DEFINE\_LOCAL\_LU or DEFINE\_TP verb that defines the LU or TP.

When an incoming Allocate request arrives for a local LU or an invocable TP that has a security access list defined, the invoking application must indicate that conversation security is to be used, and specify a user ID. In addition to the standard conversation security checking (against user IDs specified using the DEFINE\_USERID\_PASSWORD verb, or against AIX login IDs on the computer where the LU or TP runs),

## DEFINE\_SECURITY\_ACCESS\_LIST

CS/AIX checks the user ID in the incoming allocate request against the security access list defined for the LU or TP, and rejects the conversation if the user ID does not match. If both the LU and the TP have security access lists defined, the user ID must be in both lists.

If a local LU or an invocable TP does not have a security access list defined, but is still configured to require conversation security, the standard conversation security checking still applies.

## VCB structure

The DEFINE\_SECURITY\_ACCESS\_LIST verb contains a variable number of security\_user\_data structures; these define the user names to be added to the security access list. The user name structures are included at the end of the def\_data structure; the number of these structures is specified by the num\_users parameter.

```
typedef struct define_security_access_list
{
    AP_UINT16      opcode;          /* verb operation code          */
    unsigned char  reserv2;         /* reserved                      */
    unsigned char  format;         /* reserved                      */
    AP_UINT16      primary_rc;     /* primary return code          */
    AP_UINT32      secondary_rc;   /* secondary return code        */
    unsigned char  list_name[14];  /* name of this list            */
    unsigned char  reserv3[2];     /* reserved                      */
    SECURITY_LIST_DEF def_data;    /* security access list         */
} DEFINE_SECURITY_ACCESS_LIST;
```

```
typedef struct security_list_def
{
    unsigned char  description[32]; /* description                   */
    unsigned char  reserv3[16];    /* reserved                      */
    AP_UINT32      num_users;      /* number of users being added   */
    unsigned char  reserv2[16];    /* reserved                      */
} SECURITY_LIST_DEF;
```

```
typedef struct security_user_data
{
    AP_UINT16      sub_overlay_size; /* reserved                      */
    unsigned char  user_name[10];   /* user name                    */
} SECURITY_USER_DATA;
```

## Supplied parameters

The application supplies the following parameters:

### **opcode**

AP\_DEFINE\_SECURITY\_ACCESS\_LIST

### **list\_name**

Name of the security access list. This is an ASCII string, padded on the right with spaces.

If this name matches an existing security access list, the users defined by this verb are added to the list; otherwise a new list is created.

### **def\_data.description**

A null-terminated text string (0-31 characters followed by a null character) describing the security access list. This string is for information only; it is stored in the node's configuration file and returned on the QUERY\_SECURITY\_ACCESS\_LIST verb, but CS/AIX does not make any other use of it.

### **def\_data.num\_users**

Number of user names being defined by this verb. Each user must be specified by a security\_user\_data structure following the def\_data structure.

For each user name in the list, up to the number specified in num\_users, a security\_user\_data structure is required with the following information:

### **user\_name**

Name of the user.

This can be either of the following:

- An AIX login ID defined on the CS/AIX computer (if password substitution is disabled as described earlier in this section)
- A user ID defined using the DEFINE\_USERID\_PASSWORD verb

## Returned parameters: successful execution

If the verb executes successfully, CS/AIX returns the following parameters:

**primary\_rc**  
AP\_OK

## Returned parameters: parameter check

If the verb does not execute because of a parameter error, CS/AIX returns the following parameters:

**primary\_rc**  
AP\_PARAMETER\_CHECK

**secondary\_rc**  
Possible values are:

**AP\_INVALID\_LIST\_NAME**  
The *list\_name* parameter contained a character that was not valid.

**AP\_INVALID\_USER\_NAME**  
One or more of the specified user names was not valid.

Appendix B, “Common return codes,” on page 661 lists further secondary return codes associated with AP\_PARAMETER\_CHECK, which are common to all NOF verbs.

## Returned parameters: other conditions

Appendix B, “Common return codes,” on page 661 lists further combinations of primary and secondary return codes that are common to all NOF verbs.

## DEFINE\_TN3270\_ACCESS

DEFINE\_TN3270\_ACCESS defines TN3270 access details for a particular client (or default TN3270 access details for all clients) using the TN3270 Server feature of CS/AIX. (To define access details for a client using TN Redirector, use DEFINE\_TN\_REDIRECT.)

Each verb specifies details for one or more sessions. Each session is uniquely identified by the client address and the server port number. The DEFINE\_TN3270\_ACCESS verb can be used to define a new client, to define new sessions for use by an existing client, or to modify the session parameters. (To delete sessions from an existing client, use DELETE\_TN3270\_ACCESS.)

## VCB structure

The DEFINE\_TN3270\_ACCESS verb contains a variable number of `tn3270_session_def_data` structures; these define the user's sessions. The session structures are included at the end of the `def_data` structure; the number of these structures is specified by the *num\_sessions* parameter.

```
typedef struct define_tn3270_access
{
    AP_UINT16          opcode;           /* verb operation code          */
    unsigned char     reserv2;          /* reserved                      */
    unsigned char     format;           /* reserved                      */
    AP_UINT16          primary_rc;      /* primary return code          */
    AP_UINT32          secondary_rc;    /* secondary return code        */
    AP_UINT16          default_record;  /* is this the DEFAULT record?  */
    unsigned char     client_address[256]; /* address of TN3270 user      */
    TN3270_ACCESS_DEF_DATA def_data;
} DEFINE_TN3270_ACCESS;
```

## DEFINE\_TN3270\_ACCESS

```
typedef struct tn3270_access_def_data
{
    unsigned char    description[32];    /* Description - null terminated */
    unsigned char    reserv1[16];       /* reserved */
    AP_UINT16        address_format;     /* Format of client address */
    AP_UINT32        num_sessions;      /* Number of sessions being added */
    unsigned char    reserv3[64];       /* reserved */
} TN3270_ACCESS_DEF_DATA;
```

```
typedef struct tn3270_session_def_data
{
    AP_UINT16        sub_overlay_size;   /* reserved */
    unsigned char    description[32];    /* Session description */
    unsigned char    tn3270_support;     /* Level of TN3270 support */
    unsigned char    allow_specific_lu;  /* Allow access to specific LUs */
    unsigned char    printer_lu_name[8]; /* Generic printer LU/pool */
    /* accessed */
    unsigned char    reserv1[6];        /* reserved */
    AP_UINT16        port_number;        /* TCP/IP port used to access */
    /* server */
    unsigned char    lu_name[8];        /* Generic display LU/pool */
    /* accessed */
    unsigned char    session_type;      /* Unused in current version */
    unsigned char    model_override;    /* Unused in current version */
    unsigned char    ssl_enabled;       /* Is this an SSL session? */
    unsigned char    security_level;    /* SSL encryption strength */
    unsigned char    cert_key_label[80]; /* Certificate key label */
    unsigned char    listen_local_address[46]; /* Local addr client connects to */
    /* nonssl */
    unsigned char    allow_ssl_timeout_to_nonssl; /* Allow non-SSL clients on SSL? */
    unsigned char    reserv3[17];
    AP_UINT32        reserv4;           /* reserved */
} TN3270_SESSION_DEF_DATA;
```

## Supplied parameters

The application supplies the following parameters:

### **opcode**

AP\_DEFINE\_TN3270\_ACCESS

### **default\_record**

Specifies whether this verb defines a default record, which will be used by any TN3270 user not explicitly identified by a TCP/IP address. If a TN3270 user attempts to contact the TN server node, and the user's TCP/IP address does not match any DEFINE\_TN3270\_ACCESS record in the configuration but there is a default record defined, the parameters from this record will be used. Possible values are:

#### **AP\_YES**

This verb defines a default record. The *client\_address* and *address\_format* parameters are reserved.

#### **AP\_NO**

This verb defines a normal TN3270 user record.

A default record provides access to the TN server function for any TN3270 user that can determine the TCP/IP address of the computer where the TN server is running. To restrict the use of TN server to a specific group of users, either do not include the default record, or leave it with no 3270 LU or LU pool configured so that it cannot be used.

You can also set up a default record for most users, but explicitly exclude one or more TCP/IP addresses. To do this, define the addresses to be excluded as TN server users, and leave them with no 3270 LU or LU pool configured.

### **client\_address**

The TCP/IP address of the computer on which the TN3270 program runs. This is a null-terminated ASCII string, which can be any of the following; the *address\_format* parameter indicates whether it is an IP address or a name.



- An IPv4 dotted-decimal address (such as 193.1.11.100).
- An IPv6 colon-hexadecimal address (such as 2001:0db8:0000:0000:0000:0000:1428:57ab or 2001:db8::1428:57ab).
- A name (such as newbox.this.co.uk).
- An alias (such as newbox).

If you use a name or alias, the following restrictions apply:

- The AIX system must be able to resolve the name or alias to a fully qualified name (either using the local TCP/IP configuration or using a Domain Name server).
- Each name or alias must expand to a unique fully qualified name; you should not configure two names for users of the same TN server node that will be resolved to the same fully qualified name.
- Fully-qualified names are not case-sensitive; for example, Newbox.THIS.CO.UK is equivalent to newbox.this.co.uk.

#### ***def\_data.description***

An optional text string (0-31 characters followed by a null character). The string is for information only; it is stored in the configuration file and returned on a `query_tn3270_access_def` structure for a `QUERY_TN3270_ACCESS_DEF` verb, but CS/AIX does not make use of it. You can use it to store additional information to help distinguish between users.

#### ***def\_data.address\_format***

Specifies the format of the `client_address` parameter. Possible values are:

##### **AP\_ADDRESS\_IP**

IP address (either IPv4 or IPv6)

##### **AP\_ADDRESS\_FQN**

Alias or fully qualified name

#### ***def\_data.num\_sessions***

The number of sessions being defined or modified by this verb. Each TN3270 user may access the same TN server node with multiple sessions, by using a different TCP/IP port for each session. Each session must be specified by a `tn3270_session_def_data` structure following the `tn3270_access_def_data` structure.

For each session, a `tn3270_session_data` structure is required with the following information:

#### ***description***

An optional text string (0-31 characters followed by a null character). The string is for information only; it is stored in the configuration file and returned on a `query_tn3270_access_def` structure for a `QUERY_TN3270_ACCESS_DEF` verb, but CS/AIX does not make use of it.

#### ***tn3270\_support***

Specifies the level of TN3270 support. Possible values are:

##### **AP\_TN3270**

Specifies that TN3270E protocols are disabled.

##### **AP\_TN3270E**

Specifies that TN3270E protocols are enabled.

TN3270 and TN3287 protocols are always enabled.

For an AS/400 TN3270 client, this parameter must be set to `AP_TN3270E`.

#### ***allow\_specific\_lu***

Indicates whether access to specific LUs is allowed. Possible values are:

##### **AP\_YES**

Access to specific LUs is allowed.

##### **AP\_NO**

Access to specific LUs is not allowed.

***printer\_lu\_name***

Name of the printer LU or LU pool that this session uses for connections requesting a generic printer LU. This is a type-A EBCDIC string padded on the right with EBCDIC spaces. It must match the name of a LU type 0-3 printer LU defined on this node, or an LU pool containing LUs on this node.

If a single printer LU is specified, this printer LU should not be associated with any display LU by the `DEFINE_TN3270_ASSOCIATION` verb. If a printer LU pool is specified, none of the printer LUs in the pool should be associated with display LUs. Allowing a single LU to be accessed as both a generic printer LU and as an associated printer LU may result in the LU not being available as an associated printer LU because it is already in use. (These rules are not enforced by the NOF API.)

This field has no effect on specific printer LU sessions.

***port\_number***

The number of the server TCP/IP port that the TN3270 program uses to access the TN server node. If the port number matches an existing port number defined for one of this TN3270 user's sessions, the information for that session is replaced; otherwise a new session is added.

If the TN3270 program uses TCP/IP port number 23 (the port number used by the Telnet daemon program on the AIX computer), you will need to set up an additional initialization file to share this port number between TN server and the Telnet daemon program. For more information, see [“Using the Telnet Daemon's TCP/IP Port” on page 185](#).

If two or more session structures use the same *port\_number* (for the same *client\_address* or a different one), the *listen\_local\_address* parameter must be specified on all of them or none of them; you cannot specify it on some sessions but leave it unspecified on others.

***lu\_name***

Name of the LU or LU pool that this session uses for connections requesting a generic display LU. This is a type-A EBCDIC string padded on the right with EBCDIC spaces. It must match the name of a type 0-3 display LU defined on this node, or an LU pool containing LUs on this node.

If you specify an LU name, a TN3270 program with the specified TCP/IP address will be able to use only one session at a time by connecting to the specified server port number on this TN server node. If you specify an LU pool, the program can use multiple generic display LU sessions (or multiple copies of the program can access generic display LU sessions using this TN server), up to the number of LUs on this node that are available from the pool.

This parameter has no effect on specific display LU sessions.

***ssl\_enabled***

Indicates whether this session uses Secure Sockets Layer (SSL) to access the server.

This parameter is reserved if you have not installed the additional software required to support SSL on the server. You can check this by using the NOF verb `QUERY_NODE_LIMITS` and checking the value of the *ssl\_support* parameter.

Possible values are:

***AP\_NO***

This session does not use SSL.

***AP\_YES***

This session uses SSL.

***AP\_YES\_WITH\_CLI\_AUTH***

This session uses SSL, and the TN Server requires it to use client authentication. The client must send a valid certificate (information identifying it as a valid client authorized to use the TN Server).

As well as checking that the certificate is valid, the TN Server may also need to check the certificate against a certificate revocation list on an external LDAP server, to ensure that the user's authorization has not been revoked. In this case, you need to use `DEFINE_TN3270_SSL_LDAP` to specify how to access this server. If the user is permitted to use the TN3270 Express Logon feature, you also need to use `DEFINE_TN3270_EXPRESS_LOGON` to set up this feature.

**Note:**

1. If this session's *port\_number* parameter indicates that it uses the Telnet daemon's TCP/IP port, do not use SSL for this session. If you use SSL on a session that uses the Telnet daemon's TCP/IP port, Telnet clients will not be able to use `telnet` to access the CS/AIX computer while the node is active.
2. If you have large numbers of clients that use the same port, and are migrating them from non-SSL to SSL configuration, you can set up the configuration to accept both SSL and non-SSL connections on the same port while the migration is in progress. See the *allow\_ssl\_timeout\_to\_nonssl* parameter below.

### **security\_level**

Indicates the SSL security level required for this session. The session will use the highest security level that both client and server can support; if the client cannot support the requested level of security or higher, the session will not be started.

If the *ssl\_enabled* parameter is set to `AP_NO`, this parameter is reserved.

Possible values are:

#### **AP\_SSL\_AUTHENTICATE\_MIN**

Certificates must be exchanged; encryption is not required (but can be used if the client requests it).

#### **AP\_SSL\_AUTHENTICATE\_ONLY**

Certificates must be exchanged, but encryption will not be used. This option is typically used to avoid the overhead of encryption when the client is connecting across a secure intranet.

#### **AP\_SSL\_40\_BIT\_MIN**

Use at least 40-bit encryption.

#### **AP\_SSL\_56\_BIT\_MIN**

Use at least 56-bit encryption.

#### **AP\_SSL\_128\_BIT\_MIN**

Use at least 128-bit encryption.

#### **AP\_SSL\_168\_BIT\_MIN**

Use at least 168-bit encryption.

#### **AP\_SSL\_256\_BIT\_MIN**

Use at least 256-bit encryption.

**Note:** Using encryption requires additional software to be installed with CS/AIX; see *IBM Communications Server for Data Center Deployment on AIX Quick Beginnings* for more information. Depending on your location, you may not be able to use all the encryption levels listed because the software required to support them is not available in your country.

### **cert\_key\_label**

The label identifying a certificate and key pair for use with SSL on this session. This must match a label specified when the SSL keyring database was set up; see *IBM Communications Server for Data Center Deployment on AIX Quick Beginnings* for more information.

The label is a null-terminated ASCII character string. To use the default SSL certificate and key pair, specified when the SSL keyring database was set up, set this parameter to a null string.

### **listen\_local\_address**

The address on the local TN Server computer to which TN3270 clients will connect.

- If TN3270 clients are to be able to connect on any local address, or if there is only one valid local address on the TN Server, set this parameter to all binary zeros. In this case, any `tn3270_session_data` structure that uses the same *port\_number* as this one (for the same *client\_address* or a different one) must also have this parameter set to all binary zeros.
- If you need to restrict TN3270 clients to a particular local address, specify it as a null-terminated ASCII string. The address can be either of the following:
  - An IPv4 dotted-decimal address (such as `193.1.11.100`).

## DEFINE\_TN3270\_ACCESS

- An IPv6 colon-hexadecimal address (such as 2001:0db8:0000:0000:0000:0000:1428:57ab or 2001:db8::1428:57ab).

If you specify an address, any `tn3270_session_data` structure that uses the same *port\_number* as this one (for the same *client\_address* or a different one) must also have a value specified for this parameter, although the address need not be the same for all sessions.

**Note:** If you specify a local address for one or more sessions, this client record will not be displayed in the Motif administration program, so you cannot use that program to view or manage it. You can still manage it using the command-line administration program, `snaadmin`, or a NOF application.

### ***allow\_ssl\_timeout\_to\_nonssl***

This parameter does not apply if *ssl\_enabled* is set to `AP_NO`. Indicates whether non-SSL TN3270 clients can access the server using this session record even though it is configured to use SSL. Possible values are:

#### **AP\_YES**

TN3270 clients not using SSL can access the server. There will be a 5-second delay on startup while the server waits for SSL negotiation to begin; after this, the server will assume that the client is not using SSL and revert to normal TN3270 communications.

#### **AP\_NO**

Only TN3270 clients using SSL can access the server.

**Note:** This option is provided for migration purposes: if you have large numbers of clients that use the same port, and are migrating them from non-SSL to SSL configuration, you can set up the configuration to accept both SSL and non-SSL connections on the same port while the migration is in progress.

Allowing non-SSL clients to use SSL resources may be a security exposure, so this option is not intended for long-term use. You should set this parameter to `AP_YES` only for brief periods while migration is in progress, and then set it to `AP_NO` when migration is complete.

## Returned parameters: successful execution

If the verb executes successfully, CS/AIX returns the following parameters:

***primary\_rc***  
AP\_OK

## Returned parameters: parameter check

If the verb does not execute because of a parameter error, CS/AIX returns the following parameters:

***primary\_rc***  
AP\_PARAMETER\_CHECK

***secondary\_rc***  
Possible values are:

#### **AP\_UNKNOWN\_CLIENT\_ADDRESS**

The specified name or alias could not be mapped to a fully qualified name.

#### **AP\_CLIENT\_ADDRESS\_CLASH**

The fully qualified name, resolved from the *client\_address* parameter, clashes with one that has already been defined.

#### **AP\_DUPLICATE\_PORT\_NUMBER**

Another TN3270 access session record uses the same *port\_number* parameter as this one, but the *listen\_local\_address* parameters are set inconsistently. The *listen\_local\_address* must be specified on all records with the same port number, or on none of them; it cannot be specified on one but not specified on another.

#### **AP\_TCPIP\_PORT\_IN\_USE**

The TCP/IP port number cannot be used by TN server because it is already in use by a different program.

**AP\_INVALID\_TN3270\_SUPPORT**

The *tn3270\_support* parameter for one or more sessions was not set to a valid value.

Appendix B, “Common return codes,” on page 661 lists further secondary return codes associated with AP\_PARAMETER\_CHECK, which are common to all NOF verbs.

**Returned parameters: other conditions**

Appendix B, “Common return codes,” on page 661 lists further combinations of primary and secondary return codes that are common to all NOF verbs.

**Using the Telnet Daemon's TCP/IP Port**

If you are setting up TN server for use with a TN3270 program that uses TCP/IP port number 23, you will need to set up the AIX computer where the node owning this TN server runs, to share this port number between TN server and the Telnet daemon program. To do this, take the following steps:

1. Ensure that the CS/AIX software is stopped on the AIX computer.
2. Log on to the AIX computer as `root`.
3. Edit the file `/etc/inetd.conf`, and find the line beginning with `telnet`. Make a note of the full pathname for the Telnet daemon executable program, and any supplied parameters for this program, which are included at the end of this line; typically these are `/etc/telnetd` and `telnetd`. Comment out this line by inserting a `#` character at the start of the line, and save the file.
4. Create an ASCII text file `/etc/snainetd.conf`. This file should consist of a single line containing the Telnet daemon executable pathname and parameters, as determined in step 3, for example:

```
/etc/telnetd telnetd
```

5. Use the AIX `ps` command to find the process ID of the Internet daemon program `inetd`.
6. Use the AIX `kill` command to stop this process, by issuing the following command:

```
kill processid
```

*processid* is the process ID that you found in step 5.

7. Start the CS/AIX Internet daemon program, by issuing the following command:

```
snainetd
```

8. Restart the Internet daemon program, by issuing the following command:

```
inetd
```

9. Restart the CS/AIX software, and then restart the node.

Steps 5, 6, 7, and 8 must be repeated each time you restart the AIX computer. You may want to set up a shell script containing these commands, so that it can be run at startup.

**Note:** If you have set up a session to use the Telnet daemon's TCP/IP port, do not use SSL for this session. If you use SSL on a session that uses the Telnet daemon's TCP/IP port, Telnet clients will not be able to use `telnet` to access the CS/AIX computer while the node is active.

**DEFINE\_TN3270\_ASSOCIATION**

DEFINE\_TN3270\_ASSOCIATION defines an association between a display LU and a printer LU. This association allows a TN3270E client to connect to the printer LU that is associated with a display LU without knowing the name of the printer LU. The DEFINE\_TN3270\_ASSOCIATION verb can be used to define a new association or to overwrite an existing association for a particular display LU.

**VCB structure**

```
typedef struct define_tn3270_association
{
```

## DEFINE\_TN3270\_ASSOCIATION

```
AP_UINT16      opcode;          /* verb operation code      */
unsigned char  reserv2;         /* reserved                  */
unsigned char  format;         /* reserved                  */
AP_UINT16      primary_rc;     /* primary return code      */
AP_UINT32      secondary_rc;   /* secondary return code    */
unsigned char  display_lu_name[8]; /* Display LU name          */
TN3270_ASSOCIATION_DEF_DATA def_data; /* association definition    */
} DEFINE_TN3270_ASSOCIATION;

typedef struct tn3270_association_def_data
{
  unsigned char  description[32]; /* description                */
  unsigned char  reserve0[16];   /* reserved                   */
  unsigned char  printer_lu_name[8]; /* Printer LU name           */
  unsigned char  reserv2[8];     /* reserved                   */
} TN3270_ASSOCIATION_DEF_DATA;
```

## Supplied parameters

The application supplies the following parameters:

### ***opcode***

AP\_DEFINE\_TN3270\_ASSOCIATION

### ***display\_lu\_name***

Name of the display LU to be associated with the printer that was specified by the *def\_data.printer\_lu\_name* parameter. This is a type-A EBCDIC string padded on the right with EBCDIC spaces.

The specified display LU should be a display LU defined on the local node, but this is not enforced by the NOF API.

### ***def\_data.description***

Description of the association being defined. This parameter is optional.

### ***def\_data.printer\_lu\_name***

Name of the printer LU to be associated with the display LU that was specified by the *display\_lu\_name* parameter. This is a type-A EBCDIC string padded on the right with EBCDIC spaces.

The specified printer LU should be a printer LU defined on the local node.

It is not possible for a single printer LU to be shared by two TN3270E emulators; no two TN3270 associations can specify the same printer LU.

The printer LU should not be accessible as a generic printer LU; otherwise it may not be available as an associated printer LU because it is already in use. Therefore, the associated printer LU should not be configured (directly or indirectly as a member of an LU pool) as the *printer\_lu\_name* in a DEFINE\_TN3270\_ACCESS verb.

(These rules are not enforced by the NOF API.)

## Returned parameters: successful execution

If the verb executes successfully, CS/AIX returns the following parameters:

### ***primary\_rc***

AP\_OK

## Returned parameters: parameter check

If the verb does not execute because of a parameter error, CS/AIX returns the following parameters:

### ***primary\_rc***

AP\_PARAMETER\_CHECK

### ***secondary\_rc***

Possible values are:

**AP\_INVALID\_LU\_NAME**

Either the supplied display LU name or the supplied printer LU name was not a valid EBCDIC string.

Appendix B, “Common return codes,” on page 661 lists further secondary return codes associated with AP\_PARAMETER\_CHECK, which are common to all NOF verbs.

**Returned parameters: other conditions**

Appendix B, “Common return codes,” on page 661 lists further combinations of primary and secondary return codes that are common to all NOF verbs.

**DEFINE\_TN3270\_DEFAULTS**

DEFINE\_TN3270\_DEFAULTS defines TN3270 parameters used on all client sessions.

If you are using Secure Sockets Layer (SSL) client authentication, and checking clients against a certificate revocation list on an external LDAP server, you also need to configure details of how to access this server. To do this, use the DEFINE\_TN3270\_SSL\_LDAP verb.

**VCB structure**

```
typedef struct define_tn3270_defaults
{
    AP_UINT16      opcode;                /* verb operation code          */
    unsigned char  reserv2;               /* reserved                      */
    unsigned char  format;                /* reserved                      */
    AP_UINT16      primary_rc;            /* primary return code          */
    AP_UINT32      secondary_rc;         /* secondary return code        */
    TN3270_DEFAULTS_DEF_DATA def_data;   /* TN3270 defaults              */
} DEFINE_TN3270_DEFAULTS;
```

```
typedef struct tn3270_defaults_def_data
{
    unsigned char  force_responses;       /* force printer responses?     */
    unsigned char  keepalive_method;     /* method for sending keep-alives */
    AP_UINT32      keepalive_interval;   /* interval between keep-alives */
    unsigned char  reserv2[32];          /* reserved                      */
} TN3270_DEFAULTS_DEF_DATA;
```

**Supplied parameters**

The application supplies the following parameters:

***opcode***

AP\_DEFINE\_TN3270\_DEFAULTS

***def\_data.force\_responses***

Controls client responses on printer sessions. Possible values are:

**AP\_YES**

Always request definite responses from the client printer sessions. Some 3270 emulators are unable to print large jobs if definite responses are not requested. If necessary, set *force\_responses* to AP\_YES to avoid problems.

**AP\_NO**

Request responses matching SNA traffic.

***def\_data.keepalive\_method***

Method for sending keep-alive messages. Keep-alive messages are messages sent to TN3270 clients when there is no other activity on the connection, to keep the TCP/IP connections to the clients active; this ensures that failed connections and clients can be detected. If there is no traffic at all on a TCP/IP connection, failure of the connection or of the client may never be detected, which wastes TN server resources and prevents LUs from being used for other sessions.

## DEFINE\_TN3270\_EXPRESS\_LOGON

Possible values are:

### **AP\_NONE**

Do not send keep-alive messages.

### **AP\_TN3270\_NOP**

Send Telnet NOP messages.

### **AP\_TN3270\_TM**

Send Telnet DO TIMING-MARK messages.

### ***def\_data.Keepalive\_interval***

Interval (in seconds) between consecutive keep-alive messages. The interval should be long enough to minimize network traffic, especially if there are typically many idle client connections. The shorter the keep-alive interval, the quicker failures are detected, but the more network traffic is generated. If the keep-alive interval is too short and there are many clients, this traffic can be significant.

Typical values are in the range 600-7200 (10 minutes to 2 hours). The value 0 (zero) is not valid when the *keepalive\_method* parameter is set to AP\_TN3270\_NOP or AP\_TN3270\_TM.

Because of the way TCP/IP operates, the keepalive interval that you configure is not the exact time that it will take for the server to recognize that a client has disappeared. The exact time depends on various factors, but will be no more than twice the configured timeout plus a few extra minutes (the exact number depends on how TCP/IP is configured).

## Returned parameters: successful execution

If the verb executes successfully, CS/AIX returns the following parameters:

### ***primary\_rc***

AP\_OK

## Returned parameters: parameter check

If the verb does not execute because of a parameter error, CS/AIX returns the following parameters:

### ***primary\_rc***

AP\_PARAMETER\_CHECK

### ***secondary\_rc***

Possible values are:

#### **AP\_INVALID\_KEEPLIVE**

The *keepalive\_method* parameter was not set to a valid value.

Appendix B, "Common return codes," on page 661 lists further secondary return codes associated with AP\_PARAMETER\_CHECK, which are common to all NOF verbs.

## Returned parameters: other conditions

Appendix B, "Common return codes," on page 661 lists further combinations of primary and secondary return codes that are common to all NOF verbs.

## DEFINE\_TN3270\_EXPRESS\_LOGON

---

DEFINE\_TN3270\_EXPRESS\_LOGON sets up the TN3270 Express Logon feature. This feature means that TN3270 client users who connect to CS/AIX TN Server or TN Redirector using the Secure Sockets Layer (SSL) client authentication feature do not need to supply the user ID and password normally used for TN3270 security. Instead, their security certificate is checked against a Digital Certificate Access Server (DCAS) at the host, which supplies the required user ID and password.



## VCB structure

```
typedef struct define_tn3270_express_logon
{
    AP_UINT16      opcode;          /* verb operation code          */
    unsigned char  reserv2;        /* reserved                      */
    unsigned char  format;        /* reserved                      */
    AP_UINT16      primary_rc;     /* primary return code          */
    AP_UINT32      secondary_rc;   /* secondary return code        */
    unsigned char  dcas_server[256]; /* IP hostname of DCAS server  */
    AP_UINT16      dcas_port;     /* port number to access server */
    unsigned char  enabled;       /* is Express Logon enabled?    */
    unsigned char  reserv3[33];   /* reserved                      */
} DEFINE_TN3270_EXPRESS_LOGON;
```

## Supplied parameters

The application supplies the following parameters:

### ***opcode***

AP\_DEFINE\_TN3270\_EXPRESS\_LOGON

### ***dcas\_server***

The TCP/IP address of the host DCAS server that handles Express Logon authorization. This can be specified as any of the following.

- An IPv4 dotted-decimal address (such as 193.1.11.100).
- An IPv6 colon-hexadecimal address (such as 2001:0db8:0000:0000:0000:0000:1428:57ab or 2001:db8::1428:57ab).
- A name (such as newbox.this.co.uk).
- An alias (such as newbox).

If you use a name or alias, the AIX system must be able to resolve the name or alias to a fully-qualified name (either using the local TCP/IP configuration or using a Domain Name server). Fully-qualified names are not case-sensitive; for example, Newbox.THIS.CO.UK is equivalent to newbox.this.co.uk.

### ***dcas\_port***

The TCP/IP port number used to access the DCAS server.

### ***enabled***

Specifies whether the TN3270 Express Logon function is enabled. Possible values are:

#### **AP\_YES**

The function is enabled, so TN3270 clients can access the host without needing to specify a user ID and password.

#### **AP\_NO**

The function is not enabled, so TN3270 clients must specify a user ID and password.

## Returned parameters: successful execution

If the verb executes successfully, CS/AIX returns the following parameters:

### ***primary\_rc***

AP\_OK

## Returned parameters: other conditions

[Appendix B, “Common return codes,” on page 661](#) lists further combinations of primary and secondary return codes that are common to all NOF verbs.

## DEFINE\_TN3270\_SLP

DEFINE\_TN3270\_SLP specifies whether CS/AIX TN Server provides Service Location Protocol (SLP) support, and defines how the TN Server advertises its services for use by TN3270 clients. It may also specify one or more scopes, which specify the range of TN3270 SLP clients and Directory Agents to which the service is advertised.

SLP allows the TN Server to advertise the services it provides, and to advertise its current load (the percentage of its host LUs that are currently in use). An SLP-capable client with a choice of two or more TN Servers can then determine the least loaded server that provides the services it requires.

**Note:** The server on which the TN Server runs must support IPv4 addressing: that is, it must have an IPv4 address (although it may also have an IPv6 address). This is because SLP uses UDP broadcasts, which are not available in an installation that supports only IPv6.

If you use SLP, you must use DEFINE\_TN3270\_ACCESS to define at least one default TN3270 access record (to allow access to TN Server from any TN3270 client not explicitly named in the configuration). CS/AIX uses SLP to advertise these default records, which define a service that any client can access; it does not use SLP to advertise TN3270 access records for explicitly-named clients.

The DEFINE\_TN3270\_SLP verb can be used to define the SLP parameters for the first time, to modify the parameters (for example to change the scopes to which the service is advertised), or to specify that SLP is not supported.

### VCB structure

```
typedef struct define_tn3270_slp
{
    AP_UINT16      opcode;           /* verb operation code          */
    unsigned char  reserv2;         /* reserved                     */
    unsigned char  format;         /* reserved                     */
    AP_UINT16      primary_rc;     /* primary return code          */
    AP_UINT32      secondary_rc;   /* secondary return code        */
    TN3270_SLP     slp_config;     /* verb data                    */
} DEFINE_TN3270_SLP;
```

```
typedef struct tn3270_slp
{
    unsigned char  enable_load_balancing; /* Use this feature?          */
    unsigned char  reserv1;             /* Reserved                   */
    AP_UINT16      load_advertisement_freq; /* Frequency of calculating load */
    AP_UINT16      load_change_threshold; /* Change in load required to */
    unsigned char  /* readvertise                */
    AP_INT16       load_factor;         /* Percentage factor to apply to */
    unsigned char  /* load                          */
    unsigned char  num_scopes;          /* count of SLP scope names    */
    TN3270_SLP_SCOPE slp_scopes[10]; /* A set of scopes for the */
    unsigned char  /* TN3270 SLP/SA                */
    reserved[64]; /* Reserved                    */
} TN3270_SLP;
```

```
typedef struct tn3270_slp_scope
{
    unsigned char  scope[32]; /* Scope (null-terminated string) */
} TN3270_SLP_SCOPE;
```

### Supplied parameters

The application supplies the following parameters:

#### **opcode**

AP\_DEFINE\_TN3270\_SLP

#### **slp\_config.enable\_load\_balancing**

Specifies whether TN Server provides SLP support. Possible values are:

**AP\_YES**

TN Server provides SLP support. You must define at least one default TN Server access record (using DEFINE\_TN3270\_ACCESS).

**AP\_NO**

TN Server does not provide SLP support. All other parameters for this verb are reserved.

***slp\_config.load\_advertisement\_freq***

Specifies the time interval (in seconds) at which CS/AIX recalculates the load on TN Server, to determine whether the load has changed significantly and needs to be re-advertised. Allowed values are in the range 1 - 32767.

***slp\_config.load\_change\_threshold***

Specifies the change in load that is considered significant and requires re-advertising of the current load. When CS/AIX recalculates the load on TN Server, it checks whether the current load differs from the advertised load by more than this amount (either higher or lower), and advertises the new load only if the difference is significant.

Specify a percentage in the range 0 - 99. For example, if the last advertised load value is 30%, a value of 10 indicates that CS/AIX re-advertises the load only if the current load becomes higher than 40% or lower than 20%.

***slp\_config.load\_factor***

Specifies a factor that CS/AIX should apply to the advertised load, to provide better balancing between TN Servers of different capacities. For example, if one TN Server is running on a faster computer with more available memory than another TN Server, you will probably want clients to choose the first TN Server when both have the same load (in terms of the percentage of their host LUs that are in use). In this case, specify a lower *load\_factor* for the first TN Server and a higher one for the second TN Server, so that the second TN Server's advertised load is higher even when the actual percentage load is the same.

Specify a percentage in the range -100 - 100. The advertised load is calculated by adding 100 to this value and multiplying the actual percentage load by the result. For example, if you specify -80, the advertised load is the actual load multiplied by  $(-80 + 100)$  or 20%; if you specify 50, the advertised load is the actual load multiplied by  $(50 + 100)$  or 150%.

***slp\_config.num\_scopes***

The number of SLP scopes specified in the *slp\_config.slp\_scopes* array.

***slp\_config.slp\_scopes***

In a large SLP network with many TN Servers and TN3270 clients, you may need to restrict the range of TN Servers that each client can access. To do this, you can define a number of scopes, each of which identifies a logical segment of the network. Each client and each Directory Agent is assigned to a particular scope; a TN Server advertises its services only to clients and Directory Agents that have the correct scope.

To advertise the TN Server's services to any TN3270 client or Directory Agent, set each element of this array to a null string.

To restrict the TN Server to a specific scope or scopes, specify 1-10 scope names for which this TN Server provides services. Each scope name is an ASCII string (terminated by a null character); all clients and Directory Agents that are to have access to the TN Server must have a scope name defined that matches a scope name defined for the TN Server. Any unused scope names must be set to null strings.

The names LOCAL and REMOTE are reserved and must not be used for scope names.

## Returned parameters: successful execution

If the verb executes successfully, CS/AIX returns the following parameters:

***primary\_rc***

AP\_OK

## Returned parameters: parameter check

If the verb does not execute because of a parameter error, CS/AIX returns the following parameters:

### *primary\_rc*

AP\_PARAMETER\_CHECK

### *secondary\_rc*

Possible values are:

#### **AP\_INVALID\_LOAD\_BALANCING**

The *enable\_load\_balancing* parameter was not set to a valid value.

#### **AP\_INVALID\_LOAD\_FACTOR**

The *load\_factor* parameter was not within the valid range.

#### **AP\_INVALID\_FREQUENCY**

The *load\_advertisement\_freq* parameter was not within the valid range.

#### **AP\_INVALID\_NUM\_SCOPES**

The *num\_scopes* parameter was not within the valid range.

#### **AP\_INVALID\_THRESHOLD**

The *load\_change\_threshold* parameter was not within the valid range.

#### **AP\_INVALID\_SCOPE**

A scope name was set to a reserved value.

Appendix B, “Common return codes,” on page 661 lists further secondary return codes associated with AP\_PARAMETER\_CHECK, which are common to all NOF verbs.

## Returned parameters: other conditions

Appendix B, “Common return codes,” on page 661 lists further combinations of primary and secondary return codes that are common to all NOF verbs.

## DEFINE\_TN3270\_SSL\_LDAP

DEFINE\_TN3270\_SSL\_LDAP defines how to access a certificate revocation list for use with the Secure Sockets Layer (SSL) client authentication feature. The revocation list is held on an external LDAP server, and contains details of individual Telnet clients that are no longer authorized to use TN Server or TN Redirector (for example because the user's security information has been discovered by an unauthorized party, or because the user no longer works for the authorized organization).

If this feature is in use, a TN3270 client connecting to CS/AIX TN Server or TN Redirector must supply a certificate (information identifying it as a valid client authorized to use the server). The server then checks this certificate against the revocation list to ensure that it is still valid.

This verb can be used to define access to the LDAP server, to modify the access information (for example to change a user ID and password), or to specify that CS/AIX does not use a revocation list on an external LDAP server.

The verb must be issued to an inactive node; you cannot modify the LDAP server access information while the node is running.

## VCB structure

```
typedef struct define_tn3270_ssl_ldap
{
    AP_UINT16          opcode;           /* verb operation code          */
    unsigned char     reserv2;         /* reserved                      */
    unsigned char     format;         /* reserved                      */
    AP_UINT16          primary_rc;     /* primary return code          */
    AP_UINT32          secondary_rc;   /* secondary return code        */
} DEFINE_TN3270_SSL_LDAP;
```

The `define_tn3270_ssl_ldap` structure must be followed immediately by a `tn3270_ssl_ldap_def_data` structure, concatenated to the end of the VCB, as follows.

```
typedef struct tn3270_ssl_ldap_def_data
{
    AP_UINT16      overlay_size;          /* reserved */
    unsigned char  auth_type;            /* type of authorization checking */
    unsigned char  reserv1;              /* reserved */
    unsigned char  ldap_addr[256];       /* address of LDAP server */
    AP_UINT16      ldap_port;            /* port number to access server */
    unsigned char  ldap_user[1024];      /* user ID on LDAP server */
    unsigned char  ldap_password[128];   /* password on LDAP server */
    unsigned char  reserv2[256];        /* reserved */
} TN3270_SSL_LDAP_DEF_DATA;
```

## Supplied parameters

The application supplies the following parameters:

### ***opcode***

AP\_DEFINE\_TN3270\_SSL\_LDAP

### ***def\_data.auth\_type***

Specifies the type of authorization checking performed by the TN Server or TN Redirector. Possible values are:

#### **AP\_LOCAL\_ONLY**

The server checks client certificates locally, but does not use an external certificate revocation list. The parameters `ldap_addr` - `ldap_password` are reserved.

#### **AP\_LOCAL\_X500**

The server checks certificates locally, and also checks against an external certificate revocation list. The remaining parameters in this data structure specify the location of this list.

### ***def\_data.ldap\_addr***

The TCP/IP address of the LDAP server that holds the certificate revocation list. This can be specified as any of the following.

- An IPv4 dotted-decimal address (such as 193.1.11.100).
- An IPv6 colon-hexadecimal address (such as 2001:0db8:0000:0000:0000:0000:1428:57ab or 2001:db8::1428:57ab).
- A name (such as newbox.this.co.uk).
- An alias (such as newbox).

If you use a name or alias, the AIX system must be able to resolve the name or alias to a fully qualified name (either using the local TCP/IP configuration or using a Domain Name server). Fully-qualified names are not case-sensitive; for example, Newbox.THIS.CO.UK is equivalent to newbox.this.co.uk.

### ***def\_data.ldap\_port***

The TCP/IP port number used to access the LDAP server. The range is 0-65535.

### ***def\_data.ldap\_user***

The user name used to access the certificate revocation list on the LDAP server. Check with the system administrator of the LDAP server to determine how to specify this parameter.

### ***def\_data.ldap\_password***

The password used to access the certificate revocation list on the LDAP server. Check with the system administrator of the LDAP server to determine how to specify this parameter.

## Returned parameters: successful execution

If the verb executes successfully, CS/AIX returns the following parameters:

### ***primary\_rc***

AP\_OK

## Returned parameters: parameter check

If the verb does not execute because of a parameter error, CS/AIX returns the following parameters:

**primary\_rc**

AP\_PARAMETER\_CHECK

**secondary\_rc**

**AP\_INVALID\_AUTH\_TYPE**

The *auth\_type* parameter was not set to a valid value.

Appendix B, “Common return codes,” on page 661 lists further secondary return codes associated with AP\_PARAMETER\_CHECK, which are common to all NOF verbs.

## Returned parameters: function not supported

If the verb does not execute successfully because the local node does not support it, CS/AIX returns the following parameters:

**primary\_rc**

**AP\_FUNCTION\_NOT\_SUPPORTED**

The AIX Certificate and SSL Base Runtime fileset is not installed. This fileset must be installed if you want to use the SSL functions of TN Server or TN Redirector. See IBM Communications Server for Data Center Deployment on AIX Quick Beginnings for more information about installing the correct CS/AIX filesets.

## Returned parameters: other conditions

Appendix B, “Common return codes,” on page 661 lists further combinations of primary and secondary return codes that are common to all NOF verbs.

## DEFINE\_TN\_REDIRECT

DEFINE\_TN\_REDIRECT defines access details for a particular Telnet client (or default access details for all clients) using the TN Redirector feature of CS/AIX. It can be used to define a new client, or to modify the existing definition. (To define access details for a client using TN3270 Server, use DEFINE\_TN3270\_ACCESS.)

## VCB structure

```
typedef struct define_tn_redirect
{
    AP_UINT16          opcode;           /* verb operation code          */
    unsigned char     reserv2;          /* reserved                      */
    unsigned char     format;           /* reserved                      */
    AP_UINT16          primary_rc;      /* primary return code          */
    AP_UINT32          secondary_rc;    /* secondary return code        */
    TN_REDIRECT_ADDRESS addr;           /* Uniquely defines record      */
    TN_REDIRECT_DEF_DATA def_data;      /* verb data                    */
} DEFINE_TN_REDIRECT;
```

```
typedef struct tn_redirect_address
{
    AP_UINT16          default_record;   /* Is this the default record ? */
    unsigned char     address_format;    /* IP address or fully-qualified name */
    unsigned char     client_address[256]; /* Client address                */
    AP_UINT16          port_number;      /* Port number that client connects on */
    unsigned char     listen_local_address[46]; /* Local addr client connects to */
    unsigned char     reserved[34];      /* reserved                      */
} TN_REDIRECT_ADDRESS;
```

```
typedef struct tn_redirect_def_data
{
    unsigned char     description[32];    /* Description - null terminated */
}
```

```

unsigned char  reserve0[16];           /* Reserved */
unsigned char  cli_ssl_enabled;        /* Is the client session SSL? */
unsigned char  host_ssl_enabled;       /* Is the host session SSL? */
unsigned char  host_address_format;    /* Type of IP address for the host */
unsigned char  reserv1;                /* Reserved */
unsigned char  host_address[256];      /* Host address */
AP_UINT16     host_port_number;        /* Port number to connect to host */
unsigned char  cli_conn_security_level; /* SSL encryption strength */
unsigned char  serv_conn_security_level; /* SSL encryption strength */
unsigned char  cli_conn_cert_key_label[80]; /* Key label for certificate */
unsigned char  serv_conn_cert_key_label[80]; /* Key label for certificate */
unsigned char  reserved[46];           /* Reserved */
} TN_REDIRECT_DEF_DATA;

```

## Supplied parameters

The application supplies the following parameters:

### **opcode**

AP\_DEFINE\_TN\_REDIRECT

### **addr.default\_record**

Specifies whether this verb defines a default record, which will be used by any Telnet client not explicitly identified by a TCP/IP address. If a Telnet client attempts to contact the TN Redirector node, and the user's TCP/IP address does not match any DEFINE\_TN\_REDIRECT record in the configuration but there is a default record defined for the port number used by the client, the parameters from this record will be used. Possible values are:

#### **AP\_YES**

This verb defines a default record. The *client\_address* and *address\_format* parameters are reserved.

#### **AP\_NO**

This verb defines a normal TN Redirector user record.

A default record provides access to the TN Redirector function for any Telnet client that can determine the TCP/IP address of the computer where the TN server is running. To restrict the use of TN Redirector to a specific group of users, either do not include the default record, or leave it with no host address configured so that it cannot be used.

You can also set up a default record for most users, but explicitly exclude one or more TCP/IP addresses. To do this, define the addresses to be excluded as TN Redirector users, and leave them with no host address configured.

### **addr.address\_format**

Specifies the format of the *client\_address* parameter. Possible values are:

#### **AP\_ADDRESS\_IP**

IP address (either IPv4 or IPv6)

#### **AP\_ADDRESS\_FQN**

Alias or fully qualified name

### **addr.client\_address**

The TCP/IP address of the computer on which the Telnet client runs. This is a null-terminated ASCII string, which can be any of the following; the *address\_format* parameter indicates whether it is an IP address or a name.

- An IPv4 dotted-decimal address (such as 193.1.11.100).
- An IPv6 colon-hexadecimal address (such as 2001:0db8:0000:0000:0000:0000:1428:57ab or 2001:db8::1428:57ab).
- A name (such as newbox.this.co.uk).
- An alias (such as newbox).

If you use a name or alias, the following restrictions apply:

## DEFINE\_TN\_REDIRECT

- The AIX system must be able to resolve the name or alias to a fully qualified name (either using the local TCP/IP configuration or using a Domain Name server).
- Each name or alias must expand to a unique fully qualified name; you should not configure two names for users of the same TN Redirector node that will be resolved to the same fully qualified name.
- Fully-qualified names are not case-sensitive; for example, Newbox . THIS . CO . UK is equivalent to newbox . this . co . uk.

### ***addr.port\_number***

The number of the server TCP/IP port that the Telnet client uses to access the TN Redirector node.

If the *default\_record* parameter specifies that this is a default TN Redirector access record, this parameter must not match the port address used by a default TN3270 Server access record (defined using DEFINE\_TN3270\_ACCESS). You can define only one of the two types of default record for each port number.

If two or more *tn\_redirect\_address* structures use the same *port\_number* (for the same *client\_address* or a different one), the *listen\_local\_address* parameter must be specified on all of them or none of them; you cannot specify it on some sessions but leave it unspecified on others.

### ***addr.listen\_local\_address***

The address on the local TN Server computer to which TN3270 clients will connect.

- If TN3270 clients are to be able to connect on any local address, or if there is only one valid local address on the TN Server, set this parameter to all binary zeros. In this case, any *tn\_redirect\_address* structure that uses the same *port\_number* as this one (for the same *client\_address* or a different one) must also have this parameter set to all binary zeros.
- If you need to restrict TN3270 clients to a particular local address, specify it as a null-terminated ASCII string. The address can be either of the following:
  - An IPv4 dotted-decimal address (such as 193 . 1 . 11 . 100).
  - An IPv6 colon-hexadecimal address (such as 2001 : 0db8 : 0000 : 0000 : 0000 : 0000 : 1428 : 57ab or 2001 : db8 : : 1428 : 57ab).

In this case, any *tn\_redirect\_address* structure that uses the same *port\_number* as this one (for the same *client\_address* or a different one) must also have a value specified for this parameter, although the address need not be the same for all sessions.

**Note:** If you specify a local address for one or more sessions, this client record will not be displayed in the Motif administration program, so you cannot use that program to view or manage it. You can still manage it using the command-line administration program, *snaadmin*, or a NOF application.

### ***def\_data.description***

An optional text string (0-31 characters followed by a null character). The string is for information only; it is stored in the configuration file and returned on a QUERY\_TN\_REDIRECT\_DEF verb, but CS/AIX does not make use of it. You can use it to store additional information to help distinguish between users.

### ***def\_data.cli\_ssl\_enabled***

Indicates whether the client uses Secure Sockets Layer (SSL) to access the TN Redirector.

This parameter is reserved if you have not installed the additional software required to support SSL on the server. You can check this by using the NOF verb QUERY\_NODE\_LIMITS and checking the value of the *ssl\_support* parameter.

Possible values are:

#### **AP\_NO**

The client does not use SSL.

#### **AP\_YES**

The client uses SSL.



**AP\_YES\_WITH\_CLI\_AUTH**

The client uses SSL, and the TN Redirector requires it to use client authentication. The client must send a valid certificate (information identifying it as a valid client authorized to use the TN Redirector).

As well as checking that the certificate is valid, the TN Redirector may also need to check the certificate against a certificate revocation list on an external LDAP server, to ensure that the user's authorization has not been revoked. In this case, you also need to use `DEFINE_TN3270_SSL_LDAP` to specify how to access this server.

***def\_data.host\_ssl\_enabled***

Indicates whether the TN Redirector uses Secure Sockets Layer (SSL) to access the host on behalf of this client.

This parameter is reserved if you have not installed the additional software required to support SSL on the server. You can check this by using the NOF verb `QUERY_NODE_LIMITS` and checking the value of the `ssl_support` parameter.

Possible values are:

**AP\_NO**

The host does not use SSL.

**AP\_YES**

The host uses SSL.

***def\_data.host\_address\_format***

Specifies the format of the `host_address` parameter. Possible values are:

**AP\_ADDRESS\_IP**

IP address (either IPv4 or IPv6)

**AP\_ADDRESS\_FQN**

Alias or fully qualified name

***def\_data.host\_address***

The TCP/IP address of the host computer with which the client communicates. This is a null-terminated ASCII string, which can be any of the following; the `host_address_format` parameter indicates whether it is an IP address or a name.

- An IPv4 dotted-decimal address (such as `193.1.11.100`).
- An IPv6 colon-hexadecimal address (such as `2001:0db8:0000:0000:0000:0000:1428:57ab` or `2001:db8::1428:57ab`).
- A name (such as `newbox.this.co.uk`).
- An alias (such as `newbox`).

If you use a name or alias, the AIX system must be able to resolve the name or alias to a fully qualified name (either using the local TCP/IP configuration or using a Domain Name server). Fully-qualified names are not case-sensitive; for example, `Newbox.THIS.CO.UK` is equivalent to `newbox.this.co.uk`.

***def\_data.host\_port\_number***

The number of the TCP/IP port that the TN Redirector node uses to access the host.

***def\_data.cli\_conn\_security\_level***

Indicates the SSL security level required for the client connection on this session. The session will use the highest security level that both client and server can support; if the client cannot support the requested level of security or higher, the session will not be started.

If the `cli_ssl_enabled` parameter is set to `AP_NO`, this parameter is reserved.

Possible values are:

**AP\_SSL\_AUTHENTICATE\_MIN**

Certificates must be exchanged; encryption is not required (but can be used if the client requests it).

### **AP\_SSL\_AUTHENTICATE\_ONLY**

Certificates must be exchanged, but encryption will not be used. This option is typically used to avoid the overhead of encryption when the client is connecting across a secure intranet.

### **AP\_SSL\_40\_BIT\_MIN**

Use at least 40-bit encryption.

### **AP\_SSL\_56\_BIT\_MIN**

Use at least 56-bit encryption.

### **AP\_SSL\_128\_BIT\_MIN**

Use at least 128-bit encryption.

### **AP\_SSL\_168\_BIT\_MIN**

Use at least 168-bit encryption.

### **AP\_SSL\_256\_BIT\_MIN**

Use at least 256-bit encryption.

**Note:** Using encryption requires additional software to be installed with CS/AIX; see *IBM Communications Server for Data Center Deployment on AIX Quick Beginnings* for more information. Depending on your location, you may not be able to use all the encryption levels listed because the software required to support them is not available in your country.

### ***def\_data.serv\_conn\_security\_level***

Indicates the SSL security level required for the host connection on this session. The session will use the highest security level that both the host and CS/AIX can support; if the host cannot support the requested level of security or higher, the session will not be started.

If the *host\_ssl\_enabled* parameter is set to AP\_NO, this parameter is reserved.

Possible values are:

### **AP\_SSL\_AUTHENTICATE\_MIN**

Certificates must be exchanged; encryption is not required (but can be used if the host requests it).

### **AP\_SSL\_AUTHENTICATE\_ONLY**

Certificates must be exchanged, but encryption will not be used. This option is typically used to avoid the overhead of encryption when the host connection is across a secure intranet.

### **AP\_SSL\_40\_BIT\_MIN**

Use at least 40-bit encryption.

### **AP\_SSL\_56\_BIT\_MIN**

Use at least 56-bit encryption.

### **AP\_SSL\_128\_BIT\_MIN**

Use at least 128-bit encryption.

### **AP\_SSL\_168\_BIT\_MIN**

Use at least 168-bit encryption.

### **AP\_SSL\_256\_BIT\_MIN**

Use at least 256-bit encryption.

**Note:** Using encryption requires additional software to be installed with CS/AIX; see *IBM Communications Server for Data Center Deployment on AIX Quick Beginnings* for more information. Depending on your location, you may not be able to use all the encryption levels listed because the software required to support them is not available in your country.

### ***def\_data.cli\_conn\_cert\_key\_label***

The label identifying a certificate and key pair for use with SSL on the client session. This must match a label specified when the SSL keyring database was set up; see *IBM Communications Server for Data Center Deployment on AIX Quick Beginnings* for more information.

If the *cli\_ssl\_enabled* parameter is set to AP\_NO, this parameter is reserved.

The label is a null-terminated ASCII character string. To use the default SSL certificate and key pair, specified when the SSL keyring database was set up, set this parameter to a null string.

***def\_data.serv\_conn\_cert\_key\_label***

The label identifying a certificate and key pair for use with SSL on the host session. This must match a label specified when the SSL keyring database was set up; see *IBM Communications Server for Data Center Deployment on AIX Quick Beginnings* for more information.

If the *host\_ssl\_enabled* parameter is set to AP\_NO, this parameter is reserved.

The label is a null-terminated ASCII character string. To use the default SSL certificate and key pair, specified when the SSL keyring database was set up, set this parameter to a null string.

## Returned parameters: successful execution

If the verb executes successfully, CS/AIX returns the following parameters:

***primary\_rc***  
AP\_OK

## Returned parameters: parameter check

If the verb does not execute because of a parameter error, CS/AIX returns the following parameters:

***primary\_rc***  
AP\_PARAMETER\_CHECK

***secondary\_rc***  
Possible values are:

**AP\_UNKNOWN\_CLIENT\_ADDRESS**

The specified name or alias could not be mapped to a fully qualified name.

**AP\_CLIENT\_CLASH**

The combination of port number and fully qualified name (resolved from the *client\_address* parameter) clashes with one that has already been defined.

**AP\_DUPLICATE\_PORT\_NUMBER**

Another TN Redirector record uses the same *port\_number* parameter as this one, but the *listen\_local\_address* parameters are set inconsistently. The *listen\_local\_address* must be specified on all records with the same port number, or on none of them; it cannot be specified on one but not specified on another.

**AP\_TCPIP\_PORT\_IN\_USE**

The TCP/IP port number cannot be used by TN Redirector because it is already in use by a different program.

Appendix B, “Common return codes,” on page 661 lists further secondary return codes associated with AP\_PARAMETER\_CHECK, which are common to all NOF verbs.

## Returned parameters: other conditions

Appendix B, “Common return codes,” on page 661 lists further combinations of primary and secondary return codes that are common to all NOF verbs.

## DEFINE\_TP

---

The DEFINE\_TP verb provides information that CS/AIX needs to start a TP as a result of an incoming attach from a partner LU. This verb can also be used to modify one or more fields on a previously defined TP.

The standard parameters for invoked TPs are defined in the invocable TP information file (for more information, see the *IBM Communications Server for Data Center Deployment on AIX Administration Guide*). DEFINE\_TP is required only if you need to specify additional parameters that cannot be set in the

## DEFINE\_TP

file: to restrict the TP to use particular options for conversation security, confirm synchronization, or conversation type (mapped or basic), or to restrict the number of instances of the TP that can be running at any time.

## VCB structure

```
typedef struct define_tp
{
    AP_UINT16      opcode;           /* verb operation code      */
    unsigned char  reserv2;         /* reserved                  */
    unsigned char  format;          /* reserved                  */
    AP_UINT16      primary_rc;      /* primary return code      */
    AP_UINT32      secondary_rc;    /* secondary return code    */
    unsigned char  tp_name[64];     /* TP name                   */
    TP_CHARS       tp_chars;        /* TP characteristics       */
} DEFINE_TP;
```

```
typedef struct tp_chars
{
    unsigned char  description[32]; /* resource description      */
    unsigned char  security_list_name[14]; /* security access list name */
    unsigned char  reserv1[2];     /* reserved                  */
    unsigned char  conv_type;      /* conversation type         */
    unsigned char  security_rqd;   /* security support         */
    unsigned char  sync_level;     /* synchronisation level support */
    unsigned char  dynamic_load;   /* dynamic load (AP_YES)    */
    unsigned char  enabled;        /* is the TP enabled?      */
    unsigned char  pip_allowed;    /* program initialization    */
                                /* parameters supported     */
    unsigned char  reserv3[10];    /* reserved                  */
    AP_UINT16      tp_instance_limit; /* limit on currently active TP */
                                /* instances                 */
    AP_UINT16      incoming_alloc_timeout; /* incoming allocation timeout */
    AP_UINT16      rcv_alloc_timeout; /* receive allocation timeout  */
    AP_UINT16      tp_data_len;    /* reserved                  */
    unsigned char  tp_data[120];  /* reserved                  */
} TP_CHARS;
```

## Supplied parameters

The application supplies the following parameters:

### ***opcode***

AP\_DEFINE\_TP

### ***tp\_name***

Name of the TP being defined.

### ***tp\_chars.description***

A null-terminated text string (0-31 characters followed by a null character) describing the TP. This string is for information only; it is stored in the node's configuration file and returned on the QUERY\_TP\_DEFINITION and QUERY\_TP verbs, but CS/AIX does not make any other use of it.

### ***tp\_chars.security\_list\_name***

Name of the security access list used by this TP (defined using the DEFINE\_SECURITY\_ACCESS\_LIST verb). This parameter restricts the TP so that only the users named in the specified list can allocate conversations with it. If you specify a security access list, the *tp\_chars.security\_rqd* parameter must be set to AP\_YES.

To specify that the TP is available for use by any user, set this parameter to 14 binary zeros.

### ***tp\_chars.conv\_type***

Specifies the type(s) of conversation supported by this TP. Possible values are:

#### **AP\_BASIC**

The TP supports only basic conversations.

#### **AP\_MAPPED**

The TP supports only mapped conversations.

**AP\_EITHER**

The TP supports either basic or mapped conversations.

***tp\_chars.security\_rqd***

Specifies whether conversation security information is required to start the TP. Possible values are:

**AP\_YES**

A user ID and password are required to start the TP.

**AP\_NO**

No security information is required.

***tp\_chars.sync\_level***

Specifies the values of synchronization level supported by the TP. Possible values are:

**AP\_NONE**

The TP supports only *sync\_level* NONE.

**AP\_CONFIRM\_SYNC\_LEVEL**

The TP supports only *sync\_level* CONFIRM.

**AP\_EITHER**

The TP supports either *sync\_level* NONE or CONFIRM.

**AP\_SYNCPT\_REQUIRED**

The TP supports only *sync\_level* SYNCPT (syncpoint is required).

**AP\_SYNCPT\_NEGOTIABLE**

The TP supports any of the three *sync\_level* values NONE, CONFIRM, and SYNCPT.

***tp\_chars.dynamic\_load***

This parameter must be set to AP\_YES.

***tp\_chars.enabled***

Specifies whether the TP can be attached successfully. Possible values are:

**AP\_YES**

TP can be attached.

**AP\_NO**

TP cannot be attached.

***tp\_chars.pip\_allowed***

Specifies whether the TP can receive Program Initialization Parameters (PIP). Possible values are:

**AP\_YES**

TP can receive PIP.

**AP\_NO**

TP cannot receive PIP.

***tp\_chars.tp\_instance\_limit***

Limit on the number of instances of this TP that can be active at any one time. A value of zero means no limit.

***tp\_chars.incoming\_alloc\_timeout***

Specifies the number of seconds that an incoming Attach will be queued waiting for a RECEIVE\_ALLOCATE. The value 0 (zero) implies that there is no timeout; the incoming Attach will be queued indefinitely.

***tp\_chars.rcv\_alloc\_timeout***

Number of seconds that a RECEIVE\_ALLOCATE verb is queued waiting for an incoming Attach. The value 0 (zero) implies that there is no timeout; the RECEIVE\_ALLOCATE verb will be queued indefinitely.

## Returned parameters: successful execution

If the verb executes successfully, CS/AIX returns the following parameters:

## DEFINE\_TP\_LOAD\_INFO

### *primary\_rc*

AP\_OK

## Returned parameters: parameter check

If the verb does not execute because of a parameter error, CS/AIX returns the following parameters:

### *primary\_rc*

AP\_PARAMETER\_CHECK

### *secondary\_rc*

Possible values are:

#### **AP\_SYSTEM\_TP\_CANT\_BE\_CHANGED**

The specified TP name is the name of a TP used internally by CS/AIX you cannot define or modify a TP with this name.

#### **AP\_INVALID\_CONV\_TYPE**

The *conv\_type* parameter was not set to a valid value.

#### **AP\_INVALID\_SYNC\_LEVEL**

The *sync\_level* parameter was not set to a valid value.

#### **AP\_INVALID\_DYNAMIC\_LOAD**

The *dynamic\_load* parameter was not set to a valid value.

#### **AP\_INVALID\_ENABLED**

The *enabled* parameter was not set to a valid value.

#### **AP\_INVALID\_PIP\_ALLOWED**

The *pip\_allowed* parameter was not set to a valid value.

## Returned parameters: state check

If the verb does not execute because of a state error, CS/AIX returns the following parameters.

### *primary\_rc*

AP\_STATE\_CHECK

### *secondary\_rc*

Possible values are:

#### **AP\_SECURITY\_LIST\_NOT\_DEFINED**

The *security\_list\_name* parameter did not match any defined security list name.

## Returned parameters: other conditions

Appendix B, “Common return codes,” on page 661 lists further combinations of primary and secondary return codes that are common to all NOF verbs.

## DEFINE\_TP\_LOAD\_INFO

---

DEFINE\_TP\_LOAD\_INFO defines or changes an entry that describes information to be used when a transaction program is loaded. An application must issue OPEN\_FILE with a requested role of AP\_TP\_LOAD\_INFO before issuing the DEFINE\_TP\_LOAD\_INFO verb.

## VCB structure

```
typedef struct define_tp_load_info
{
    AP_UINT16          opcode;          /* verb operation code          */
    unsigned char     reserv2;         /* reserved                      */
    unsigned char     format;         /* reserved                      */
    AP_UINT16          primary_rc;     /* primary return code          */
    AP_UINT32          secondary_rc;   /* secondary return code        */
    unsigned char     tp_name[64];    /* TP name                      */
    unsigned char     lu_alias[8];     /* LU alias                    */
}
```

```

    TP_LOAD_INFO_DEF_DATA def_data;          /* defined data          */
} DEFINE_TP_LOAD_INFO;

typedef struct tp_load_info_def_data
{
    unsigned char    description[32];        /* Description            */
    unsigned char    reserv1[16];           /* reserved                */
    unsigned char    user_id[64];           /* User ID                 */
    unsigned char    group_id[64];          /* Group ID                */
    AP_UINT32        timeout;               /* Timeout value          */
    unsigned char    type;                  /* TP type                 */
    unsigned char    style;                 /* reserved                */
    AP_UINT16        ltv_length;            /* Length of LTV data     */
} TP_LOAD_INFO_DEF_DATA;

```

## Supplied parameters

The application supplies the following parameters:

### ***opcode***

AP\_DEFINE\_TP\_LOAD\_INFO

### ***tp\_name***

The TP name of the TP load info entry to be defined. This is a 64-byte EBCDIC string, padded on the right with spaces if the name is shorter than 64 characters.

### ***lu\_alias***

The LU alias of the TP load info entry to be defined. This is an 8-byte ASCII character string.

**Note:** This parameter can be used only if the TP is an APPC TP. If the TP is a CPI-C application, this parameter is reserved and must be set to all zeros. CPI-C does not support accepting incoming Attaches from a particular local LU; specifying an LU alias (even a blank LU alias) for a CPI-C application will cause errors in routing the incoming Attach to the TP.

### ***def\_data.description***

A null-terminated text string (0-32 characters followed by a null character) describing the TP load info. This string is for information only; it is stored in the node's configuration file and returned on the QUERY\_TP verb, but CS/AIX does not make any other use of it.

### ***def\_data.user\_id***

User ID required to access and run the TP.

### ***def\_data.group\_id***

Group ID required to access and run the TP.

### ***def\_data.timeout***

Timeout in seconds after the TP is loaded.

### ***def\_data.type***

Specifies the TP type. Possible values are:

AP\_TP\_TYPE\_QUEUED

AP\_TP\_TYPE\_QUEUED\_BROADCAST

AP\_TP\_TYPE\_NON\_QUEUED

### ***def\_data.ltv\_length***

Length of the block of LTV data that is appended to this verb. Each LTV structure is specified in TP\_LOAD\_INFO\_LTV.

### ***TP\_LOAD\_INFO\_LTV***

The LTV data is specified as a series of non-byte-aligned LTVs each of which consists of the following:

- A 2-byte length field with a maximum value of 258 bytes. This field is in line format and is read or written using NB\_PUT\_SHORT or NB\_GET\_SHORT.
- A 1-byte type field set to one of the following possible values:

## DEFINE\_TP\_LOAD\_INFO

### AP\_TYPE\_TP\_PATH

Path. The value string specifies the full path name of the TP executable.

### AP\_TYPE\_TP\_ARGUMENTS

Arguments. The value string specifies a command-line argument required by the TP.

### AP\_TYPE\_TP\_STDIN

Standard input. The value string specifies the full path name of the standard input file or device. If this LTV is not specified, the default is `/dev/null`.

### AP\_TYPE\_TP\_STDOUT

Standard output. The value string specifies the full path name of the standard output file or device. If this LTV is not specified, the default is `/dev/null`.

### AP\_TYPE\_TP\_STDERR

Standard error. The value string specifies the full path name of the standard error file or device. If this LTV is not specified, the default is `/dev/null`.

### AP\_TYPE\_TP\_ENV

Environment. The value string specifies an environment variables required by the TP, in the form `VARIABLE = VALUE`.

If the TP is a CPI-C application, note that you cannot set the environment variable APPCLLU using this LTV. The local LU cannot be specified in the TP load information for an automatically-loaded CPI-C application.

- A value field consisting of up to 255 bytes of ASCII data.

## Returned parameters: successful execution

If the verb executes successfully, CS/AIX returns the following parameters:

*primary\_rc*

AP\_OK

## Returned parameters: parameter check

If the verb does not execute because of a parameter error, CS/AIX returns the following parameters:

*primary\_rc*

AP\_PARAMETER\_CHECK

*secondary\_rc*

Possible values are:

### AP\_INVALID\_TP\_TYPE

The *type* parameter was not set to a valid value.

### AP\_INVALID\_LTV\_LENGTH

An LTV *length* parameter was not set to a valid value.

### AP\_INVALID\_LTV\_TYPE

The LTV *type* parameter was not set to a valid value.

### AP\_INVALID\_LTV\_VALUE

An LTV *value* parameter contained data that was not valid.

### AP\_INVALID\_TP\_STYLE

The TP *style* parameter contains a value that is not valid.

### AP\_INVALID\_TP\_NAME

The TP *name* parameter contains EBCDIC spaces.

Appendix B, "Common return codes," on page 661 lists further secondary return codes associated with AP\_PARAMETER\_CHECK, which are common to all NOF verbs.



## Returned parameters: other conditions

Appendix B, “Common return codes,” on page 661 lists further combinations of primary and secondary return codes that are common to all NOF verbs.

## DEFINE\_USERID\_PASSWORD

DEFINE\_USERID\_PASSWORD defines a user ID / password pair for use with APPC and CPI-C conversation security, or adds profiles for a defined user ID and password.

### VCB structure

```
typedef struct define_userid_password
{
    AP_UINT16          opcode;           /* verb operation code      */
    unsigned char     reserv2;          /* reserved                  */
    unsigned char     format;           /* reserved                  */
    AP_UINT16          primary_rc;      /* primary return code      */
    AP_UINT32          secondary_rc;    /* secondary return code    */
    AP_UINT16          define_type;     /* what the define type is  */
    unsigned char     user_id[10];     /* user id                   */
    unsigned char     reserv3[8];      /* reserved                  */
    USERID_PASSWORD_CHARS password_chars; /* password characteristics */
} DEFINE_USERID_PASSWORD;
```

```
typedef struct userid_password_chars
{
    unsigned char     description[32];  /* resource description      */
    unsigned char     reserv2[16];     /* reserved                  */
    AP_UINT16          profile_count;   /* number of profiles       */
    AP_UINT16          reserv1;        /* reserved                  */
    unsigned char     password[10];    /* password                  */
    unsigned char     profiles[10][10]; /* profiles                  */
} USERID_PASSWORD_CHARS;
```

## Supplied parameters

The application supplies the following parameters:

### ***opcode***

AP\_DEFINE\_USERID\_PASSWORD

### ***define\_type***

Specifies how this verb is being used. Possible values are:

#### **AP\_ADD\_USER**

Add a new user, or change the password for an existing user.

#### **AP\_ADD\_PROFILES**

Add to the profiles for an existing user.

### ***user\_id***

User identifier. This is a 10-byte type-AE EBCDIC character string, padded on the right with EBCDIC spaces.

Some CPI-C implementations have a maximum user ID length of 8 characters. If you specify a user ID of 9 or 10 characters, CPI-C applications running on other systems may not be able to access applications on the CS/AIX system using this user ID and password.

### ***password\_chars.description***

A null-terminated text string (0-31 characters followed by a null character) describing the user ID and password. This string is for information only; it is stored in the node's configuration file and returned on the QUERY\_USERID\_PASSWORD verb, but CS/AIX does not make any other use of it.

### ***password\_chars.profile\_count***

Number of profiles. This parameter is normally set to zero; see *password\_chars.profiles* below for more information.

## DEFINE\_USERID\_PASSWORD

### ***password\_chars.password***

User's password. This is a 10-byte type-AE EBCDIC character string, padded on the right with EBCDIC spaces.

Some CPI-C implementations have a maximum password length of 8 characters. If you specify a password of 9 or 10 characters, CPI-C applications running on other systems may not be able to access applications on the CS/AIX system using this user ID and password.

Whatever value the application supplies for this parameter is immediately replaced by the encrypted version of the password. Therefore, the value supplied for the *password\_chars.password* parameter is never written out.

### ***password\_chars.profiles***

Profile names associated with the user ID and password. Each of these is a 10-byte type-AE EBCDIC character string, padded on the right with EBCDIC spaces.

If a remote TP uses this user ID and password to contact the local TP, and specifies a profile on the Attach, this must match one of the profile names defined here. Check with the remote System Administrator to determine if a profile will be used; for each profile that will be used, specify the profile name as one of the *profiles* parameters on this verb. In most cases, profile names are not used, and so there is no need to specify them on this verb; set *password\_chars.profile\_count* to zero and do not specify any profiles.

## Returned parameters: successful execution

If the verb executes successfully, CS/AIX returns the following parameters:

### ***primary\_rc***

AP\_OK

## Returned parameters: parameter check

If the verb does not execute because of a parameter error, CS/AIX returns the following parameters:

### ***primary\_rc***

AP\_PARAMETER\_CHECK

### ***secondary\_rc***

Possible values are:

#### **AP\_INVALID\_PASSWORD**

The *password* parameter contained a character that was not valid.

#### **AP\_INVALID\_PROFILE**

One or more of the specified profiles was not valid.

#### **AP\_INVALID\_UPDATE\_TYPE**

The *define\_type* parameter was not set to a valid value.

#### **AP\_INVALID\_USERID**

The *user\_id* parameter contained a character that was not valid.

#### **AP\_NO\_PROFILES**

The verb was used to add profiles to an existing user, but no profiles were specified.

#### **AP\_TOO\_MANY\_PROFILES**

The *profile\_count* parameter was not set to a valid value.

#### **AP\_UNKNOWN\_USER**

The verb was used to add profiles to an existing user, but the *user\_id* parameter did not match an existing user ID.

Appendix B, "Common return codes," on page 661 lists further secondary return codes associated with AP\_PARAMETER\_CHECK, which are common to all NOF verbs.

## Returned parameters: other conditions

Appendix B, “Common return codes,” on page 661 lists further combinations of primary and secondary return codes that are common to all NOF verbs.

## DELETE\_ADJACENT\_LEN\_NODE

DELETE\_ADJACENT\_LEN\_NODE removes entries in the node directory database for an adjacent LEN node and its associated LUs, or removes LU entries for the LEN node without removing the LEN node itself. It is equivalent to issuing a series of DELETE\_DIRECTORY\_ENTRY verbs for the LEN node and its associated LUs.

## VCB structure

```
typedef struct delete_adjacent_len_node
{
    AP_UINT16      opcode;           /* verb operation code          */
    unsigned char  reserv2;         /* reserved                     */
    unsigned char  format;         /* reserved                     */
    AP_UINT16      primary_rc;     /* primary return code         */
    AP_UINT32      secondary_rc;   /* secondary return code       */
    unsigned char  cp_name[17];    /* CP name                     */
    unsigned char  num_of_lus;     /* number of LUs              */
    unsigned char  lu_names[10][8]; /* LU names                   */
    unsigned char  wildcard_lus;   /* wildcard LUs               */
} DELETE_ADJACENT_LEN_NODE;
```

## Supplied parameters

The application supplies the following parameters:

### **opcode**

AP\_DELETE\_ADJACENT\_LEN\_NODE

### **cp\_name**

The fully qualified name of the CP in the adjacent LEN node. The name is a 17-byte EBCDIC string, right-padded with EBCDIC spaces. It consists of a network ID of up to 8 A-string characters, an EBCDIC dot (period) character, and a network name of up to 8 A-string characters.

### **num\_of\_lus**

The number of LUs to be deleted, in the range 1 to 10. To delete the entire LEN node definition, specify zero.

### **lu\_names**

The names of the LUs on the LEN node to be deleted. Each name is an 8-byte type-A EBCDIC character string, right-padded with EBCDIC spaces. Do not specify any LU names if you are deleting the entire LEN node definition (if *num\_of\_lus* is zero).

You can specify a "wildcard" LU name to match multiple LU names, by specifying only the initial characters of the name. For example, the wildcard LU name APPN.LU will match APPN.LUNAME or APPN.LU01 (but will not match APPN.NAME.LU). However, all the LU names specified on a single verb must be of the same type (wildcard or explicit), as defined by the *wildcard\_lus* parameter below. To remove both types of LU names from the same LEN node, use multiple DELETE\_ADJACENT\_LEN\_NODE verbs.

### **wildcard\_lus**

Indicates whether the specified LU names are wildcard entries or explicit LU names. Possible values are:

#### **AP\_YES**

The specified LU names are wildcard entries.

#### **AP\_NO**

The specified LU names are explicit entries.

## Returned parameters: successful execution

If the verb executes successfully, CS/AIX returns the following parameters:

**primary\_rc**  
AP\_OK

## Returned parameters: parameter check

If the verb does not execute because of a parameter error, CS/AIX returns the following parameters:

**primary\_rc**  
AP\_PARAMETER\_CHECK

**secondary\_rc**  
Possible values are:

**AP\_INVALID\_CP\_NAME**  
The *cp\_name* parameter contained a character that was not valid.

**AP\_INVALID\_LU\_NAME**  
One or more of the specified LU names contained a character that was not valid.

**AP\_INVALID\_NUM\_LUS**  
The *num\_of\_lus* parameter was not in the valid range.

## Returned parameters: state check

If the verb does not execute because of a state error, CS/AIX returns the following parameters.

**primary\_rc**  
AP\_STATE\_CHECK

**secondary\_rc**  
Possible values are:

**AP\_INVALID\_CP\_NAME**  
The specified CP name does not exist.

**AP\_INVALID\_LU\_NAME**  
One or more of the specified LU names does not exist.

## Returned parameters: other conditions

Appendix B, “Common return codes,” on [page 661](#) lists further combinations of primary and secondary return codes that are common to all NOF verbs.

## DELETE\_BACKUP

---

An application uses this verb to delete a server from the list of backup servers in the `sna.net` file, so that this server can no longer act as the controlling configuration file server.

You can use this verb to delete any server in the list, including the controller server, whether or not the SNA software is running on the server you are deleting. The only restriction is that the list must always contain at least one server on which the SNA software is running (so that this server can take over as the controller server); you cannot delete a server if it is the only server in the list or if it is the only server listed on which the SNA software is running.

This verb must be issued to the `sna.net` file.

## VCB structure

```
typedef struct delete_backup
{
    AP_UINT16          opcode;          /* verb operation code      */
    unsigned char     reserv2;        /* reserved                  */
};
```

```

unsigned char    format;                /* reserved          */
AP_UINT16       primary_rc;            /* primary return code */
AP_UINT32       secondary_rc;         /* secondary return code */
unsigned char    backup_name[128];     /* name of server to delete */
unsigned char    reserv3[4];          /* reserved          */
} DELETE_BACKUP;

```

## Supplied parameters

The application supplies the following parameters:

### **opcode**

AP\_DELETE\_BACKUP

### **backup\_name**

The name of the server being deleted from the list of backup servers.

If the server name includes a . (period) character, CS/AIX assumes that it is a fully-qualified name; otherwise it performs a DNS lookup to determine the server name.

## Returned parameters: successful execution

If the verb executes successfully, CS/AIX returns the following parameters:

### **primary\_rc**

AP\_OK

### **secondary\_rc**

Not used.

## Returned parameters: state check

If the verb does not execute because of a state check, CS/AIX returns the following parameters:

### **primary\_rc**

AP\_STATE\_CHECK

### **secondary\_rc**

Possible values are:

#### **AP\_RECORD\_NOT\_FOUND**

The server name specified is not listed in the file.

#### **AP\_CANT\_DELETE\_LAST\_BACKUP**

The server name cannot be deleted from the list, because it is the only server listed on which the SNA software is running (and hence the only server that can currently act as the controller). Before attempting to delete it, either start the SNA software on one or more of the other servers listed, or add one or more new backup servers (using ADD\_BACKUP) and ensure that the SNA software is started on these servers.

#### **AP\_INVALID\_TARGET**

The target handle on the NOF API call specified a configuration file or a node. This verb must be issued to the sna.net file.

Appendix B, “Common return codes,” on page 661 lists further secondary return codes associated with AP\_STATE\_CHECK, which are common to all NOF verbs.

## Returned parameters: other conditions

Appendix B, “Common return codes,” on page 661 lists further combinations of primary and secondary return codes that are common to all NOF verbs.

## DELETE\_CN

DELETE\_CN deletes a connection network, or deletes selected ports from a connection network.

## DELETE\_CN

This verb is valid only at a network node or an end node, and not at a LEN node.

### VCB structure

```
typedef struct delete_cn
{
    AP_UINT16      opcode;          /* verb operation code          */
    unsigned char  reserv2;        /* reserved                      */
    unsigned char  format;        /* reserved                      */
    AP_UINT16      primary_rc;     /* primary return code          */
    AP_UINT32      secondary_rc;   /* secondary return code        */
    unsigned char  fqcn_name[17]; /* name of Connection Network   */
    unsigned char  reserv1;        /* reserved                      */
    AP_UINT16      num_ports;      /* number of ports to delete    */
    unsigned char  port_name[8][8]; /* names of ports to delete     */
} DELETE_CN;
```

### Supplied parameters

The application supplies the following parameters:

#### ***opcode***

AP\_DELETE\_CN

#### ***fqcn\_name***

Fully qualified name of the connection network. The name is a 17-byte EBCDIC string, right-padded with EBCDIC spaces. It consists of a network ID of up to 8 A-string characters, an EBCDIC dot (period) character, and a network name of up to 8 A-string characters.

#### ***num\_ports***

Specify zero to delete the connection network, or the number of ports to be deleted if you are removing ports instead of deleting the connection network.

#### ***port\_name***

If you are removing ports (if *num\_ports* is nonzero), specify the names of the ports to be deleted. Each port name is an 8-byte ASCII string, padded on the right with spaces if the name is shorter than 8 bytes. If you are deleting the connection network (if *num\_ports* is zero), these names must be set to binary zeros.

### Returned parameters: successful execution

If the verb executes successfully, CS/AIX returns the following parameters:

#### ***primary\_rc***

AP\_OK

### Returned parameters: parameter check

If the verb does not execute because of a parameter error, CS/AIX returns the following parameters:

#### ***primary\_rc***

AP\_PARAMETER\_CHECK

#### ***secondary\_rc***

Possible values are:

##### **AP\_INVALID\_CN\_NAME**

The fully-qualified CN name specified did not match any defined CN name.

##### **AP\_INVALID\_NUM\_PORTS\_SPECIFIED**

The *num\_ports* parameter was not set to a valid value.

Appendix B, "Common return codes," on page 661 lists further secondary return codes associated with AP\_PARAMETER\_CHECK, which are common to all NOF verbs.

## Returned parameters: function not supported

If the verb does not execute successfully because the local node is a LEN node, CS/AIX returns the following parameters:

### *primary\_rc*

#### **AP\_FUNCTION\_NOT\_SUPPORTED**

The local node is a LEN node. This verb is valid only at a network node or an end node.

## Returned parameters: other conditions

Appendix B, “Common return codes,” on page 661 lists further combinations of primary and secondary return codes that are common to all NOF verbs.

## DELETE\_COS

---

DELETE\_COS deletes a class of service entry. Only locally defined classes of service can be deleted; the default classes of service defined by SNA cannot be deleted.

If the node supports mode to COS mapping (as defined by the *mode\_to\_cos\_map\_supp* parameter on DEFINE\_NODE) and the configuration includes modes that are mapped to the COS that you are deleting, CS/AIX will remap these modes to the default COS (specified by a DEFINE\_MODE verb with a null mode name) or to the SNA-defined COS #CONNECT if no default COS is specified.

## VCB structure

```
typedef struct delete_cos
{
    AP_UINT16      opcode;           /* verb operation code      */
    unsigned char  reserv2;         /* reserved                  */
    unsigned char  format;         /* reserved                  */
    AP_UINT16      primary_rc;     /* primary return code      */
    AP_UINT32      secondary_rc;   /* secondary return code    */
    unsigned char  cos_name[8];    /* class of service name    */
} DELETE_COS;
```

## Supplied parameters

The application supplies the following parameters:

### *opcode*

AP\_DELETE\_COS

### *cos\_name*

Class of service name. This is an 8-byte type-A EBCDIC string (starting with a letter), padded on the right with EBCDIC spaces.

## Returned parameters: successful execution

If the verb executes successfully, CS/AIX returns the following parameters:

### *primary\_rc*

AP\_OK

## Returned parameters: parameter check

If the verb does not execute because of a parameter error, CS/AIX returns the following parameters:

### *primary\_rc*

AP\_PARAMETER\_CHECK

### *secondary\_rc*

Possible values are:

## DELETE\_CPIC\_SIDE\_INFO

### AP\_COS\_NAME\_NOT\_DEFD

The supplied name is not the name of a COS defined on the CS/AIX system.

### AP\_SNA\_DEFD\_COS\_CANT\_BE\_DELETED

The supplied name is the name of one of the SNA-defined classes of service, which cannot be deleted.

Appendix B, “Common return codes,” on page 661 lists further secondary return codes associated with AP\_PARAMETER\_CHECK, which are common to all NOF verbs.

## Returned parameters: other conditions

Appendix B, “Common return codes,” on page 661 lists further combinations of primary and secondary return codes that are common to all NOF verbs.

## DELETE\_CPIC\_SIDE\_INFO

---

This verb deletes an entry from the side information table.

Note the difference between this verb and the CPI-C function Delete\_CPIC\_Side\_Information. This verb modifies a configuration file, so that it affects all CS/AIX CPI-C applications. The CPI-C function modifies the application's own copy in memory of the side information table, and does not affect any other CPI-C applications.

This verb must be issued to the domain configuration file.

## VCB structure

```
typedef struct delete_cplic_side_info
{
    AP_UINT16          opcode;           /* verb operation code      */
    unsigned char     reserv2;         /* reserved                  */
    unsigned char     format;          /* reserved                  */
    AP_UINT16          primary_rc;      /* primary return code      */
    AP_UINT32          secondary_rc;    /* secondary return code    */
    unsigned char     reserv2a[8];     /* reserved                  */
    unsigned char     sym_dest_name[8]; /* Symbolic destination name */
} DELETE_CPIC_SIDE_INFO;
```

## Supplied parameters

The application supplies the following parameters:

### *opcode*

AP\_DELETE\_CPIC\_SIDE\_INFO

### *sym\_dest\_name*

Symbolic destination name which identifies the side information entry. This is an 8-byte ASCII string, consisting of uppercase A-Z and digits 0-9, padded on the right with spaces if necessary.

## Returned parameters: successful execution

If the verb executes successfully, CS/AIX returns the following parameters:

### *primary\_rc*

AP\_OK

## Returned parameters: state check

If the verb does not execute because of a state error, CS/AIX returns the following parameters:

### *primary\_rc*

AP\_STATE\_CHECK



**secondary\_rc****AP\_INVALID\_SYM\_DEST\_NAME**

The *sym\_dest\_name* parameter was not the name of a defined CPI-C side information entry.

Appendix B, “Common return codes,” on page 661 lists further secondary return codes associated with AP\_STATE\_CHECK, which are common to all NOF verbs.

**Returned parameters: other conditions**

Appendix B, “Common return codes,” on page 661 lists further combinations of primary and secondary return codes that are common to all NOF verbs.

**DELETE\_DIRECTORY\_ENTRY**

DELETE\_DIRECTORY\_ENTRY deletes an entry in the Network Directory. You cannot delete the entry for an end node CP from the directory of its network node server.

If the entry for a parent resource is deleted, then all entries for child resources associated with it are also deleted. For example, if you delete the entry for a network node that is the parent of an end node, then the entries for the end node and all LUs associated with both nodes (including wildcard LU entries) are deleted as well as the entry for the network node.

**VCB structure**

```
typedef struct delete_directory_entry
{
    AP_UINT16      opcode;           /* verb operation code          */
    unsigned char  reserv2;         /* reserved                     */
    unsigned char  format;         /* reserved                     */
    AP_UINT16      primary_rc;     /* primary return code          */
    AP_UINT32      secondary_rc;   /* secondary return code        */
    unsigned char  resource_name[17]; /* fully qualified resource name */
    unsigned char  reserv3;         /* reserved                     */
    AP_UINT16      resource_type;   /* resource type                */
} DELETE_DIRECTORY_ENTRY;
```

**Supplied parameters**

The application supplies the following parameters:

**opcode**

AP\_DELETE\_DIRECTORY\_ENTRY

**resource\_name**

Fully qualified name of the resource to be deleted. The name is a 17-byte EBCDIC string, right-padded with EBCDIC spaces. It consists of a network ID of up to 8 A-string characters, an EBCDIC dot (period) character, and a network name of up to 8 A-string characters.

**resource\_type**

Specifies the type of the resource to be deleted. Possible values are:

**AP\_ENCP\_RESOURCE**

End node or LEN node

**AP\_NNCP\_RESOURCE**

Network node

**AP\_LU\_RESOURCE**

LU

**AP\_WILDCARD\_LU\_RESOURCE**

Wildcard LU name.

## Returned parameters: successful execution

If the verb executes successfully, CS/AIX returns the following parameters:

**primary\_rc**  
AP\_OK

## Returned parameters: parameter check

If the verb does not execute because of a parameter error, CS/AIX returns the following parameters:

**primary\_rc**  
AP\_PARAMETER\_CHECK

**secondary\_rc**  
Possible values are:

**AP\_INVALID\_FQ\_LU\_NAME**  
The *resource\_name* parameter was not the name of a defined directory entry.

**AP\_INVALID\_RESOURCE\_TYPE**  
The *resource\_type* parameter was not set to a valid value.

Appendix B, “Common return codes,” on page 661 lists further secondary return codes associated with AP\_PARAMETER\_CHECK, which are common to all NOF verbs.

## Returned parameters: state check

If the verb does not execute because of a state error, CS/AIX returns the following parameters.

**primary\_rc**  
AP\_STATE\_CHECK

**secondary\_rc**

**AP\_CANT\_DELETE\_ADJ\_ENDNODE**  
The specified entry is for an end node, and the node to which this verb was issued is its network node server. You cannot delete this end node entry.

Appendix B, “Common return codes,” on page 661 lists further secondary return codes associated with AP\_STATE\_CHECK, which are common to all NOF verbs.

## Returned parameters: other conditions

Appendix B, “Common return codes,” on page 661 lists further combinations of primary and secondary return codes that are common to all NOF verbs.

## DELETE\_DLC

---

DELETE\_DLC deletes a DLC. This verb also deletes the following:

- All ports, link stations and connection network TGs associated with the DLC
- All PUs associated with LSs on the DLC, all LUs owned by these PUs, and all LU-LU passwords associated with these LUs.

## VCB structure

```
typedef struct delete_dlc
{
    AP_UINT16          opcode;          /* verb operation code      */
    unsigned char     reserv2;         /* reserved                  */
    unsigned char     format;         /* reserved                  */
    AP_UINT16         primary_rc;     /* primary return code      */
    AP_UINT32         secondary_rc;   /* secondary return code    */
}
```

```

    unsigned char    dlc_name[8];          /* name of DLC          */
} DELETE_DLC;

```

## Supplied parameters

The application supplies the following parameters:

### *opcode*

AP\_DELETE\_DLC

### *dlc\_name*

Name of DLC to be deleted. This is an 8-byte ASCII string, padded on the right with spaces if the name is shorter than 8 bytes.

## Returned parameters: successful execution

If the verb executes successfully, CS/AIX returns the following parameters:

### *primary\_rc*

AP\_OK

## Returned parameters: parameter check

If the verb does not execute because of a parameter error, CS/AIX returns the following parameters:

### *primary\_rc*

AP\_PARAMETER\_CHECK

### *secondary\_rc*

#### **AP\_INVALID\_DLC\_NAME**

The supplied DLC name was not the name of a DLC defined on the CS/AIX system.

Appendix B, “Common return codes,” on page 661 lists further secondary return codes associated with AP\_PARAMETER\_CHECK, which are common to all NOF verbs.

## Returned parameters: state check

If the verb does not execute because of a state error, CS/AIX returns the following parameters.

### *primary\_rc*

AP\_STATE\_CHECK

### *secondary\_rc*

#### **AP\_DLC\_ACTIVE**

The DLC cannot be deleted because it is currently active. Use the STOP\_DLC verb to stop it before attempting to delete it.

Appendix B, “Common return codes,” on page 661 lists further secondary return codes associated with AP\_STATE\_CHECK, which are common to all NOF verbs.

## Returned parameters: other conditions

Appendix B, “Common return codes,” on page 661 lists further combinations of primary and secondary return codes that are common to all NOF verbs.

## DELETE\_DOWNSTREAM\_LU

---

This verb is used to delete a downstream LU.

## VCB structure

```
typedef struct delete_downstream_lu
{
    AP_UINT16      opcode;           /* verb operation code      */
    unsigned char  reserv2;         /* reserved                  */
    unsigned char  format;          /* reserved                  */
    AP_UINT16      primary_rc;      /* primary return code      */
    AP_UINT32      secondary_rc;    /* secondary return code    */
    unsigned char  dslu_name[8];    /* Downstream LU name      */
} DELETE_DOWNSTREAM_LU;
```

## Supplied parameters

The application supplies the following parameters:

### *opcode*

AP\_DELETE\_DOWNSTREAM\_LU

### *dslu\_name*

Name of the downstream LU that is being deleted. This is an 8-byte type A EBCDIC string (starting with a letter), padded on the right with EBCDIC spaces if the name is shorter than 8 characters.

## Returned parameters: successful execution

If the verb executes successfully, CS/AIX returns the following parameters:

### *primary\_rc*

AP\_OK

## Returned parameters: parameter check

If the verb does not execute because of a parameter error, CS/AIX returns the following parameters:

### *primary\_rc*

AP\_PARAMETER\_CHECK

### *secondary\_rc*

#### **AP\_INVALID\_LU\_NAME**

The *dslu\_name* parameter contained a character that was not valid.

Appendix B, “Common return codes,” on page 661 lists further secondary return codes associated with AP\_PARAMETER\_CHECK, which are common to all NOF verbs.

## Returned parameters: state check

If the verb does not execute because of a state error, CS/AIX returns the following parameters.

### *primary\_rc*

AP\_STATE\_CHECK

### *secondary\_rc*

Possible values are:

#### **AP\_INVALID\_LU\_NAME**

The *dslu\_name* parameter did not match any defined downstream LU name.

#### **AP\_DSLU\_ACTIVE**

The LU cannot be deleted because it is currently active.

Appendix B, “Common return codes,” on page 661 lists further secondary return codes associated with AP\_STATE\_CHECK, which are common to all NOF verbs.

## Returned parameters: function not supported

If the verb does not execute because the node's configuration does not support it, CS/AIX returns the following parameters:

### *primary\_rc*

#### **AP\_FUNCTION\_NOT\_SUPPORTED**

The local node does not support SNA gateway; this is defined by the *pu\_conc\_support* parameter on the DEFINE\_NODE verb.

## Returned parameters: other conditions

Appendix B, “Common return codes,” on page 661 lists further combinations of primary and secondary return codes that are common to all NOF verbs.

## DELETE\_DOWNSTREAM\_LU\_RANGE

This verb is used to delete a range of downstream LUs.

The supplied parameters to this verb include a base name for the LUs and the range of NAU addresses. The LU names to be deleted are determined by combining the base name with the NAU addresses. For example, a base name of LUNME combined with a NAU range of 11 to 14 would delete the LUs LUNME011, LUNME012, LUNME013, and LUNME014.

All LUs with names in the specified range are deleted; CS/AIX does not return an error if one or more names in the range do not exist.

## VCB structure

```
typedef struct delete_downstream_lu_range
{
    AP_UINT16      opcode;          /* verb operation code          */
    unsigned char  reserv2;        /* reserved                      */
    unsigned char  format;         /* reserved                      */
    AP_UINT16      primary_rc;     /* primary return code          */
    AP_UINT32      secondary_rc;   /* secondary return code        */
    unsigned char  dslu_base_name[5]; /* LU base name                */
    unsigned char  min_nau;        /* Minimum NAU address in range */
    unsigned char  max_nau;        /* Maximum NAU address in range */
} DELETE_DOWNSTREAM_LU_RANGE;
```

## Supplied parameters

The application supplies the following parameters:

### *opcode*

AP\_DELETE\_DOWNSTREAM\_LU\_RANGE

### *dslu\_base\_name*

Base name for the names of the LUs. This is a 5-byte type-A EBCDIC string (starting with a letter), padded on the right with EBCDIC spaces if the base name is less than 5 characters. CS/AIX determines the names of the LUs to be deleted by appending the 3-digit decimal value of each NAU address to this name.

### *min\_nau*

NAU address of the first LU, in the range 1-255.

### *max\_nau*

NAU address of the last LU, in the range 1-255.

## Returned parameters: successful execution

If the verb executes successfully, CS/AIX returns the following parameters:

## DELETE\_DSPU\_TEMPLATE

### *primary\_rc*

AP\_OK

## Returned parameters: parameter check

If the verb does not execute because of a parameter error, CS/AIX returns the following parameters:

### *primary\_rc*

AP\_PARAMETER\_CHECK

### *secondary\_rc*

Possible values are:

#### **AP\_INVALID\_NAU\_ADDRESS**

The *min\_nau* or *max\_nau* parameter was not valid.

#### **AP\_INVALID\_LU\_NAME**

The *dslu\_base\_name* parameter contained a character that was not valid.

Appendix B, “Common return codes,” on page 661 lists further secondary return codes associated with AP\_PARAMETER\_CHECK, which are common to all NOF verbs.

## Returned parameters: state check

If the verb does not execute because of a state error, CS/AIX returns the following parameters.

### *primary\_rc*

AP\_STATE\_CHECK

### *secondary\_rc*

Possible values are:

#### **AP\_INVALID\_LU\_NAME**

There were no LUs defined with names in the specified range.

#### **AP\_DSLU\_ACTIVE**

One or more of the LUs in the range cannot be deleted because it is currently active.

Appendix B, “Common return codes,” on page 661 lists further secondary return codes associated with AP\_STATE\_CHECK, which are common to all NOF verbs.

## Returned parameters: function not supported

If the verb does not execute because the node's configuration does not support it, CS/AIX returns the following parameters:

### *primary\_rc*

#### **AP\_FUNCTION\_NOT\_SUPPORTED**

The local node does not support SNA gateway; this is defined by the *pu\_conc\_support* parameter on the DEFINE\_NODE verb.

## Returned parameters: other conditions

Appendix B, “Common return codes,” on page 661 lists further combinations of primary and secondary return codes that are common to all NOF verbs.

## DELETE\_DSPU\_TEMPLATE

---

The DELETE\_DSPU\_TEMPLATE verb deletes a specific downstream physical unit (DSPU) template that was previously defined using a DEFINE\_DSPU\_TEMPLATE verb, or deletes one or more downstream LU (DSLUs) templates from a DSPU template.

## VCB structure

```
typedef struct delete_dspu_template
{
    AP_UINT16      opcode;                /* verb operation code      */
    unsigned char  reserv2;               /* reserved                  */
    unsigned char  format;                /* reserved                  */
    AP_UINT16      primary_rc;            /* primary return code      */
    AP_UINT32      secondary_rc;          /* secondary return code    */
    unsigned char  template_name[8];     /* name of template        */
    AP_UINT16      num_of_dslu_templates; /* number of dslu templates */
    unsigned char  reserv1[10];          /* reserved                  */
} DELETE_DSPU_TEMPLATE;
```

```
typedef struct dslu_template
{
    unsigned char  min_nau;               /* Minimum NAU address in range */
    unsigned char  max_nau;               /* Maximum NAU address in range */
    unsigned char  allow_timeout;         /* Allow timeout of host LU?    */
    unsigned char  delayed_logon;        /* Allow delayed logon to host  */
                                           /* LU                            */
    unsigned char  reserv1[8];           /* reserved                    */
    unsigned char  host_lu[8];           /* Host LU or Pool name        */
} DSLU_TEMPLATE;
```

## Supplied parameters

Supplied parameters are:

### **opcode**

AP\_DELETE\_DSPU\_TEMPLATE

### **template\_name**

Name of the DSPU template to be deleted, or the DSPU template containing the DSLU templates to be deleted. Specify 1-8 locally displayable characters.

### **num\_of\_dslu\_templates**

Number of DSLU templates to be deleted. Specify a value in the range 1-255, or specify 0 (zero) to delete the entire DSPU template.

For each DSLU template to be deleted, up to the number specified in *num\_of\_dslu\_templates*, append a DSLU\_TEMPLATE structure to the end of the DELETE\_DSPU\_TEMPLATE structure, containing the following parameters:

### **min\_nau**

Minimum NAU address in the range of DSLU templates to be deleted. Specify a value in the range 1-255.

### **max\_nau**

Maximum NAU address in the range of DSLU templates to be deleted. Specify a value in the range 1-255.

### **allow\_timeout**

Specifies whether CS/AIX is allowed to timeout host LUs used by this downstream LU if the session is left inactive for the timeout period specified on the host LU definition. Possible values are:

#### **AP\_YES**

CS/AIX is allowed to timeout host LUs used by this downstream LU.

#### **AP\_NO**

CS/AIX is not allowed to timeout host LUs used by this downstream LU.

### **delayed\_logon**

Specifies whether CS/AIX delays connecting the downstream LU to the host LU until the first data is received from the downstream LU. Instead, a simulated logon screen is sent to the downstream LU. Possible values are:

## DELETE\_FOCAL\_POINT

### AP\_YES

CS/AIX delays connecting the downstream LU to the host LU until the first data is received from the downstream LU.

### AP\_NO

CS/AIX does not delay connecting the downstream LU to the host LU until the first data is received from the downstream LU.

### *host\_lu*

Name of the host LU or host LU pool onto which all the downstream LUs within the range will be mapped.

## Returned parameters: successful execution

If the verb executes successfully, CS/AIX returns the following parameters:

### *primary\_rc*

AP\_OK

## Returned parameters: parameter check

If the verb does not execute because of a parameter error, CS/AIX returns the following parameters:

### *primary\_rc*

AP\_PARAMETER\_CHECK

### *secondary\_rc*

Possible values are:

#### **AP\_INVALID\_TEMPLATE\_NAME**

The template specified by the *template\_name* parameter was not valid.

Appendix B, “Common return codes,” on page 661 lists further secondary return codes associated with AP\_PARAMETER\_CHECK, which are common to all NOF verbs.

## Returned parameters: other conditions

Appendix B, “Common return codes,” on page 661 lists further combinations of primary and secondary return codes that are common to all NOF verbs.

## DELETE\_FOCAL\_POINT

---

The DELETE\_FOCAL\_POINT verb removes the definition of a focal point for a specified MS category (either the main focal point for that category or a backup focal point). If the defined focal point application is active and acting as the current focal point for that category, CS/AIX sends an MS\_CAPABILITIES message to the focal point to revoke it so that it no longer acts as the focal point.

## VCB structure

```
typedef struct delete_focal_point
{
    AP_UINT16          opcode;          /* verb operation code          */
    unsigned char     reserv2;         /* reserved                     */
    unsigned char     format;         /* reserved                     */
    AP_UINT16          primary_rc;     /* primary return code         */
    AP_UINT32          secondary_rc;   /* secondary return code       */
    unsigned char     reserved;       /* reserved                     */
    unsigned char     ms_category[8]; /* management services category */
    unsigned char     type;           /* type of focal point         */
} DELETE_FOCAL_POINT;
```

## Supplied parameters

The application supplies the following parameters:



**opcode**

AP\_DELETE\_FOCAL\_POINT

**ms\_category**

Management Services category. This may be either one of the category names specified in the MS Discipline-Specific Application Programs table of *Systems Network Architecture: Management Services Reference* (see the Bibliography), padded with EBCDIC spaces (0x40), or a user-defined category. A user-defined category name is an 8-byte type-1134 EBCDIC string, padded with EBCDIC spaces (0x40) if necessary.

**type**

Specifies the type of the focal point that is being deleted. Possible values are:

**AP\_ACTIVE**

The currently active focal point (which may be of any type) is revoked.

**AP\_IMPLICIT**

The implicit definition (defined using DEFINE\_FOCAL\_POINT with backup set to AP\_NO) is removed. If this focal point is currently active, then it is revoked.

**AP\_BACKUP**

The backup definition (defined using DEFINE\_FOCAL\_POINT with backup set to AP\_YES) is removed. If this focal point is currently active, then it is revoked.

**Returned parameters: successful execution**

If the verb executes successfully, CS/AIX returns the following parameters:

**primary\_rc**

AP\_OK

**Returned parameters: parameter check**

If the verb does not execute because of a parameter error, CS/AIX returns the following parameters:

**primary\_rc**

AP\_PARAMETER\_CHECK

**secondary\_rc**

Possible values are:

**AP\_INVALID\_CATEGORY\_NAME**

The supplied category name contained a character that was not valid.

**AP\_INVALID\_TYPE**

The *type* parameter was not set to a valid value.

Appendix B, “Common return codes,” on page 661 lists further secondary return codes associated with AP\_PARAMETER\_CHECK, which are common to all NOF verbs.

**Returned parameters: function not supported**

If the verb does not execute successfully because the local node configuration does not support it, CS/AIX returns the following parameters:

**primary\_rc****AP\_FUNCTION\_NOT\_SUPPORTED**

The local node does not support MS network management functions; this is defined by the *mds\_supported* parameter on the DEFINE\_NODE verb.

**Returned parameters: other conditions**

Appendix B, “Common return codes,” on page 661 lists further combinations of primary and secondary return codes that are common to all NOF verbs.

## DELETE\_INTERNAL\_PU

DELETE\_INTERNAL\_PU deletes a DLUR-served local PU. The PU can be deleted only if it does not have an active SSCP-PU session.

### VCB structure

```
typedef struct delete_internal_pu
{
    AP_UINT16      opcode;          /* verb operation code          */
    unsigned char  reserv2;        /* reserved                      */
    unsigned char  format;         /* reserved                      */
    AP_UINT16      primary_rc;     /* primary return code          */
    AP_UINT32      secondary_rc;   /* secondary return code        */
    unsigned char  pu_name[8];     /* internal PU name             */
} DELETE_INTERNAL_PU;
```

### Supplied parameters

The application supplies the following parameters:

#### ***opcode***

AP\_DELETE\_INTERNAL\_PU

#### ***pu\_name***

Name of the internal PU that is being deleted. This is an 8-byte type-A EBCDIC string (starting with a letter), padded on the right with EBCDIC spaces.

### Returned parameters: successful execution

If the verb executes successfully, CS/AIX returns the following parameters:

#### ***primary\_rc***

AP\_OK

### Returned parameters: parameter check

If the verb does not execute because of a parameter error, CS/AIX returns the following parameters:

#### ***primary\_rc***

AP\_PARAMETER\_CHECK

#### ***secondary\_rc***

**AP\_INVALID\_PU\_NAME**

The *pu\_name* parameter was not the name of a defined internal PU.

### Returned parameters: state check

If the verb does not execute because of a state error, CS/AIX returns the following parameters.

#### ***primary\_rc***

AP\_STATE\_CHECK

#### ***secondary\_rc***

Possible values are:

**AP\_PU\_NOT\_RESET**

The PU cannot be deleted because it still has an active PU-SSCP session.

**AP\_INVALID\_PU\_TYPE**

The specified PU is a remote PU and not an internal PU.

## Returned parameters: function not supported

If the verb does not execute because the node's configuration does not support it, CS/AIX returns the following parameter:

### *primary\_rc*

#### **AP\_FUNCTION\_NOT\_SUPPORTED**

The node does not support DLUR; this is defined by the *dlur\_support* parameter on DEFINE\_NODE.

## Returned parameters: other conditions

Appendix B, “Common return codes,” on page 661 lists further combinations of primary and secondary return codes that are common to all NOF verbs.

## DELETE\_LOCAL\_LU

---

The DELETE\_LOCAL\_LU verb deletes a local LU, and also deletes any LU-LU passwords associated with the local LU.

## VCB structure

```
typedef struct delete_local_lu
{
    AP_UINT16          opcode;           /* verb operation code      */
    unsigned char     reserv2;         /* reserved                  */
    unsigned char     format;          /* reserved                  */
    AP_UINT16          primary_rc;      /* primary return code      */
    AP_UINT32          secondary_rc;    /* secondary return code    */
    unsigned char     lu_name[8];      /* local LU name            */
} DELETE_LOCAL_LU;
```

## Supplied parameters

The application supplies the following parameters:

### *opcode*

AP\_DELETE\_LOCAL\_LU

### *lu\_name*

Name of the local LU to be deleted. This is an 8-byte type-A EBCDIC string (starting with a letter), padded on the right with EBCDIC spaces if the name is shorter than 8 characters.

## Returned parameters: successful execution

If the verb executes successfully, CS/AIX returns the following parameters:

### *primary\_rc*

AP\_OK

## Returned parameters: parameter check

If the verb does not execute because of a parameter error, CS/AIX returns the following parameters:

### *primary\_rc*

AP\_PARAMETER\_CHECK

### *secondary\_rc*

Possible values are:

#### **AP\_CANT\_DELETE\_CP\_LU**

The supplied LU name was blank (indicating the LU associated with the CP); this LU cannot be deleted.

## DELETE\_LS

### AP\_INVALID\_LU\_NAME

The supplied LU name is not the name of a local LU defined on the CS/AIX system.

Appendix B, “Common return codes,” on page 661 lists further secondary return codes associated with AP\_PARAMETER\_CHECK, which are common to all NOF verbs.

## Returned parameters: other conditions

Appendix B, “Common return codes,” on page 661 lists further combinations of primary and secondary return codes that are common to all NOF verbs.

## DELETE\_LS

---

DELETE\_LS deletes a defined Link Station (LS). This verb also deletes the PU associated with the LS, all LUs owned by this PU, and all LU-LU passwords associated with these LUs. The LS cannot be deleted if it is active.

## VCB structure

```
typedef struct delete_ls
{
    AP_UINT16      opcode;           /* verb operation code      */
    unsigned char  reserv2;         /* reserved                  */
    unsigned char  format;          /* reserved                  */
    AP_UINT16      primary_rc;      /* primary return code      */
    AP_UINT32      secondary_rc;    /* secondary return code    */
    unsigned char  ls_name[8];      /* name of link station     */
} DELETE_LS;
```

## Supplied parameters

The application supplies the following parameters:

### *opcode*

AP\_DELETE\_LS

### *ls\_name*

Name of link station being deleted. This is an 8-byte ASCII string, padded on the right with spaces if the name is shorter than 8 characters.

## Returned parameters: successful execution

If the verb executes successfully, CS/AIX returns the following parameters:

### *primary\_rc*

AP\_OK

## Returned parameters: parameter check

If the verb does not execute because of a parameter error, CS/AIX returns the following parameters:

### *primary\_rc*

AP\_PARAMETER\_CHECK

### *secondary\_rc*

#### AP\_INVALID\_LINK\_NAME

The supplied LS name contains a character that was not valid.

Appendix B, “Common return codes,” on page 661 lists further secondary return codes associated with AP\_PARAMETER\_CHECK, which are common to all NOF verbs.

## Returned parameters: state check

If the verb does not execute because of a state error, CS/AIX returns the following parameters.

### *primary\_rc*

AP\_STATE\_CHECK

### *secondary\_rc*

Possible values are:

#### **AP\_LS\_ACTIVE**

The LS cannot be deleted because it is currently active.

#### **AP\_INVALID\_LINK\_NAME**

The supplied LS name is not the name of an LS defined on the CS/AIX system.

Appendix B, “Common return codes,” on page 661 lists further secondary return codes associated with AP\_STATE\_CHECK, which are common to all NOF verbs.

## Returned parameters: other conditions

Appendix B, “Common return codes,” on page 661 lists further combinations of primary and secondary return codes that are common to all NOF verbs.

## DELETE\_LS\_ROUTING

The DELETE\_LS\_ROUTING verb deletes the association of a partner LU to a link station that was previously defined using the DEFINE\_LS\_ROUTING verb.

## VCB structure

```
typedef struct delete_ls_routing
{
    AP_UINT16      opcode;          /* verb operation code      */
    unsigned char  reserv2;        /* reserved                  */
    unsigned char  format;        /* reserved                  */
    AP_UINT16      primary_rc;     /* primary return code      */
    AP_UINT32      secondary_rc;   /* secondary return code    */
    unsigned char  lu_name[8];     /* LU Name                   */
    unsigned char  lu_alias[8];   /* reserved                  */
    unsigned char  fq_partner_lu[17]; /* partner lu name          */
    unsigned char  wildcard_fqplu; /* wildcard partner LU flag */
    unsigned char  reserv3[2];    /* reserved                  */
} DELETE_LS_ROUTING;
```

## Supplied parameters

The application supplies the following parameters:

### *opcode*

AP\_DELETE\_LS\_ROUTING

### *lu\_name*

Name of the local LU that communicated with the partner LU (specified by the *fq\_partner\_lu* parameter). Specify 1-8 locally displayable characters.

### *fq\_partner\_lu*

Fully qualified name of the partner LU to be removed from the local LU's LS routing data. Specify 3-17 locally displayable characters that consist of a 1-8 character network name, followed by a period, followed by a 1-8 character partner LU name.

To delete a wildcard entry, specify the same wildcard LU name that you used to define the entry. You cannot use wildcards to delete more than one explicitly-defined entry.

## DELETE\_LS\_ROUTING

### *wildcard\_fqplu*

Wildcard partner LU flag indicating whether the *fq\_partner\_lu* parameter contains a full or partial wildcard. This flag is used to delete a wildcard entry; you cannot use wildcards to delete more than one explicitly-defined entry. Possible values are:

#### **AP\_YES**

The *fq\_partner\_lu* parameter contains a wildcard entry.

#### **AP\_NO**

The *fq\_partner\_lu* parameter does not contain a wildcard entry.

## Returned parameters: successful execution

If the verb executes successfully, CS/AIX returns the following parameters:

### *primary\_rc*

AP\_OK

## Returned parameters: parameter check

If the verb does not execute because of a parameter error, CS/AIX returns the following parameters:

### *primary\_rc*

AP\_PARAMETER\_CHECK

### *secondary\_rc*

Possible values are:

#### **AP\_INVALID\_LOCAL\_LU**

The *lu\_name* parameter contained a character that was not valid.

#### **AP\_INVALID\_PARTNER\_LU**

The *fq\_partner\_lu* parameter contained a character that was not valid.

#### **AP\_INVALID\_WILDCARD\_NAME**

The *wildcard\_fqplu* parameter was set to AP\_YES, but the *fq\_partner\_lu* parameter was not a valid wildcard name.

Appendix B, “Common return codes,” on page 661 lists further secondary return codes associated with AP\_PARAMETER\_CHECK, which are common to all NOF verbs.

## Returned parameters: state check

If the verb does not execute because of a state error, CS/AIX returns the following parameters.

### *primary\_rc*

AP\_STATE\_CHECK

### *secondary\_rc*

Possible values are:

#### **AP\_INVALID\_LOCAL\_LU**

The *lu\_name* parameter did not match an existing LS routing record.

#### **AP\_INVALID\_PARTNER\_LU**

The *fq\_partner\_lu* parameter did not match an existing LS routing record for the specified local LU.

#### **AP\_INVALID\_WILDCARD\_NAME**

The *wildcard\_fqplu* parameter was set to YES, but no matching entry was found.

#### **AP\_INVALID\_RESOURCE\_NAME**

No LS routing entry that matched the supplied parameters was found.

Appendix B, “Common return codes,” on page 661 lists further secondary return codes associated with AP\_STATE\_CHECK, which are common to all NOF verbs.

## Returned parameters: other conditions

Appendix B, “Common return codes,” on page 661 lists further combinations of primary and secondary return codes that are common to all NOF verbs.

## DELETE\_LU62\_TIMEOUT

The DELETE\_LU62\_TIMEOUT verb deletes a definition of an LU type 6.2 session timeout that was defined previously with a DEFINE\_LU62\_TIMEOUT verb.

### VCB structure

```
typedef struct delete_lu62_timeout
{
    AP_UINT16      opcode;           /* verb operation code      */
    unsigned char  reserv2;         /* reserved                  */
    unsigned char  format;         /* reserved                  */
    AP_UINT16      primary_rc;     /* primary return code      */
    AP_UINT32      secondary_rc;   /* secondary return code    */
    unsigned char  resource_type;  /* resource type            */
    unsigned char  resource_name[17]; /* resource name            */
} DELETE_LU62_TIMEOUT;
```

### Supplied parameters

Supplied parameters are:

#### ***opcode***

AP\_DELETE\_LU62\_TIMEOUT

#### ***resource\_type***

Specifies the type of timeout being deleted. Possible values are:

##### **AP\_GLOBAL\_TIMEOUT**

Delete timeouts that apply to all LU 6.2 sessions for the local node.

##### **AP\_LOCAL\_LU\_TIMEOUT**

Delete timeouts that apply to all LU 6.2 sessions for the local LU specified in the *resource\_name* parameter.

##### **AP\_PARTNER\_LU\_TIMEOUT**

Delete timeouts that apply to all LU 6.2 sessions to the partner LU specified in the *resource\_name* parameter.

##### **AP\_MODE\_TIMEOUT**

Delete timeouts that apply to all LU 6.2 sessions on the mode specified in the *resource\_name* parameter.

#### ***resource\_name***

Name of the resource whose timeout is being deleted. This value can be one of the following:

- If *resource\_type* is set to AP\_GLOBAL\_TIMEOUT, do not specify this parameter.
- If *resource\_type* is set to AP\_LOCAL\_LU\_TIMEOUT, specify 1-8 locally displayable type-A characters as a local LU name.
- If *resource\_type* is set to AP\_PARTNER\_LU\_TIMEOUT, specify the fully qualified name of the partner LU as follows: 17 locally displayable type-A characters consisting of a 1-8 character network name, followed by a period, followed by a 1-8 character partner LU name.
- If *resource\_type* is set to AP\_MODE\_TIMEOUT, specify 1-8 locally displayable type-A characters as a mode name.

### Returned parameters: successful execution

If the verb executes successfully, CS/AIX returns the following parameters:

## DELETE\_LU\_0\_TO\_3

### *primary\_rc*

AP\_OK

## Returned parameters: parameter check

If the verb does not execute because of a parameter error, CS/AIX returns the following parameters:

### *primary\_rc*

AP\_PARAMETER\_CHECK

### *secondary\_rc*

Possible values are:

#### **AP\_INVALID\_RESOURCE\_TYPE**

The value specified in the *resource\_type* parameter was not valid.

#### **AP\_INVALID\_LU\_NAME**

The LU name specified in the *resource\_name* parameter was not valid.

#### **AP\_INVALID\_PARTNER\_LU**

The partner LU name specified in the *resource\_name* parameter was not valid.

#### **AP\_INVALID\_MODE\_NAME**

The mode name specified in the *resource\_name* parameter was not valid.

#### **AP\_GLOBAL\_TIMEOUT\_NOT\_DEFINED**

The value AP\_GLOBAL\_TIMEOUT was specified for the *resource\_type* parameter but there is no defined global timeout.

Appendix B, “Common return codes,” on page 661 lists further secondary return codes associated with AP\_PARAMETER\_CHECK, which are common to all NOF verbs.

## Returned parameters: other conditions

Appendix B, “Common return codes,” on page 661 lists further combinations of primary and secondary return codes that are common to all NOF verbs.

## DELETE\_LU\_0\_TO\_3

---

This verb is used to delete an LU used for 3270 emulation or LUA (an LU of type 0-3).

## VCB structure

```
typedef struct delete_lu_0_to_3
{
    AP_UINT16          opcode;          /* verb operation code      */
    unsigned char     reserv2;         /* reserved                 */
    unsigned char     format;         /* reserved                 */
    AP_UINT16         primary_rc;     /* primary return code     */
    AP_UINT32         secondary_rc;  /* secondary return code   */
    unsigned char     lu_name[8];     /* LU name                  */
} DELETE_LU_0_TO_3;
```

## Supplied parameters

The application supplies the following parameters:

### *opcode*

AP\_DELETE\_LU\_0\_TO\_3

### *lu\_name*

Name of the local LU to be deleted. This is an 8-byte type-A EBCDIC string (starting with a letter), padded on the right with EBCDIC spaces if the name is shorter than 8 characters.



## Returned parameters: successful execution

If the verb executes successfully, CS/AIX returns the following parameters:

*primary\_rc*  
AP\_OK

## Returned parameters: parameter check

If the verb does not execute because of a parameter error, CS/AIX returns the following parameters:

*primary\_rc*  
AP\_PARAMETER\_CHECK

*secondary\_rc*

**AP\_INVALID\_LU\_NAME**

The supplied LU name contained a character that was not valid.

Appendix B, “Common return codes,” on page 661 lists further secondary return codes associated with AP\_PARAMETER\_CHECK, which are common to all NOF verbs.

## Returned parameters: state check

If the verb does not execute because of a state error, CS/AIX returns the following parameters.

*primary\_rc*  
AP\_STATE\_CHECK

*secondary\_rc*

**AP\_INVALID\_LU\_NAME**

The supplied LU name is not the name of an LU defined on the CS/AIX system.

Appendix B, “Common return codes,” on page 661 lists further secondary return codes associated with AP\_STATE\_CHECK, which are common to all NOF verbs.

## Returned parameters: other conditions

Appendix B, “Common return codes,” on page 661 lists further combinations of primary and secondary return codes that are common to all NOF verbs.

## DELETE\_LU\_0\_TO\_3\_RANGE

This verb is used to delete a range of LUs used for 3270 emulation or LUA (type 0-3 LUs).

The supplied parameters to this verb include a base name for the LUs and the range of NAU addresses. The LU names to be deleted are determined by combining the base name with the NAU addresses. For example, a base name of LUNME combined with a NAU range of 11-14 would delete the LUs LUNME011, LUNME012, LUNME013, and LUNME014.

All LUs with names in the specified range are deleted; CS/AIX does not return an error if one or more names in the range do not exist.

## VCB structure

```
typedef struct delete_lu_0_to_3_range
{
    AP_UINT16      opcode;          /* verb operation code          */
    unsigned char  reserv2;         /* reserved                      */
    unsigned char  format;         /* reserved                      */
    AP_UINT16      primary_rc;     /* primary return code          */
    AP_UINT32      secondary_rc;   /* secondary return code        */
    unsigned char  base_name[6];   /* Base name                    */
    unsigned char  min_nau;        /* Minimum NAU address in range */
    unsigned char  max_nau;        /* Maximum NAU address in range */
    unsigned char  name_attributes; /* Extension type                */
}
```

## DELETE\_LU\_0\_TO\_3\_RANGE

```
    unsigned char    base_number;    /* First extension number    */
    unsigned char    reserv5[16];    /* reserved                    */
} DELETE_LU_0_TO_3_RANGE;
```

### Supplied parameters

The application supplies the following parameters:

#### **opcode**

AP\_DELETE\_LU\_0\_TO\_3\_RANGE

#### **base\_name**

Base name for the names of the LUs. This is a type-A EBCDIC string (starting with a letter), padded on the right with EBCDIC spaces if the base name is less than 6 characters. It may be either 5 bytes or 6 bytes long, as determined by the *name\_attributes* parameter. CS/AIX determines the names of the LUs to be deleted by appending the decimal value of each NAU address (or a number in the range starting from the *base\_number* parameter) to this name.

#### **min\_nau**

NAU address of the first LU, in the range 1-255.

#### **max\_nau**

NAU address of the last LU, in the range 1-255.

#### **name\_attributes**

Specifies the extension type of the LUs. Possible values are:

##### **AP\_NONE**

LU names have numbers that correspond to the NAU numbers. The numbers are specified in decimal and the *base\_name* parameter can contain only five characters.

##### **AP\_USE\_BASE\_NUMBER**

Start deleting the LUs in the range from the value specified in the *base\_number* parameter.

##### **AP\_USE\_HEX\_IN\_NAME**

The extension to the LU name is in hex rather than decimal. The *base\_name* parameter can contain 6 characters if this value is specified.

#### **base\_number**

If AP\_USE\_BASE\_NUMBER is specified in the *name\_attributes* parameter, specify a number from which to start deleting the LUs in the range. This value will be used instead of the value of the *min\_nau* parameter.

### Returned parameters: successful execution

If the verb executes successfully, CS/AIX returns the following parameters:

#### **primary\_rc**

AP\_OK

### Returned parameters: parameter check

If the verb does not execute because of a parameter error, CS/AIX returns the following parameters:

#### **primary\_rc**

AP\_PARAMETER\_CHECK

#### **secondary\_rc**

Possible values are:

##### **AP\_INVALID\_NAU\_ADDRESS**

The *min\_nau* or *max\_nau* parameter was not valid.

##### **AP\_INVALID\_LU\_NAME**

The *base\_name* parameter contained a character that was not valid.

Appendix B, “Common return codes,” on page 661 lists further secondary return codes associated with AP\_PARAMETER\_CHECK, which are common to all NOF verbs.

## Returned parameters: state check

If the verb does not execute because of a state error, CS/AIX returns the following parameters.

### *primary\_rc*

AP\_STATE\_CHECK

### *secondary\_rc*

#### **AP\_INVALID\_LU\_NAME**

There were no LUs defined with names in the specified range.

Appendix B, “Common return codes,” on page 661 lists further secondary return codes associated with AP\_STATE\_CHECK, which are common to all NOF verbs.

## Returned parameters: other conditions

Appendix B, “Common return codes,” on page 661 lists further combinations of primary and secondary return codes that are common to all NOF verbs.

## DELETE\_LU\_LU\_PASSWORD

DELETE\_LU\_LU\_PASSWORD deletes an LU-LU password associated with a local LU. LU-LU passwords are deleted automatically when the local LU is deleted; you need only use this verb if you need to remove the password but leave the LU configured.

## VCB structure

```
typedef struct delete_lu_lu_password
{
    AP_UINT16      opcode;           /* verb operation code          */
    unsigned char  reserv2;         /* reserved                      */
    unsigned char  format;         /* reserved                      */
    AP_UINT16      primary_rc;     /* primary return code          */
    AP_UINT32      secondary_rc;   /* secondary return code        */
    unsigned char  lu_name[8];     /* LU name                      */
    unsigned char  lu_alias[8];    /* local LU alias               */
    unsigned char  fqplu_name[17]; /* fully qualified partner LU name */
    unsigned char  reserv3;         /* reserved                      */
} DELETE_LU_LU_PASSWORD;
```

## Supplied parameters

The application supplies the following parameters:

### *opcode*

AP\_DELETE\_LU\_LU\_PASSWORD

### *lu\_name*

LU name of the local LU, as defined to CS/AIX. This is an 8-byte type-A EBCDIC string, padded on the right with spaces if the name is shorter than 8 bytes. To indicate that the LU is defined by its LU alias instead of its LU name, set this parameter to 8 binary zeros.

### *lu\_alias*

LU alias of the local LU, as defined to CS/AIX. This is an 8-byte ASCII string, using any locally displayable characters, padded on the right with spaces if the name is shorter than 8 bytes. It is used only if *lu\_name* is set to zeros.

To indicate the LU associated with the CP (the default LU), set both *lu\_name* and *lu\_alias* to 8 binary zeros.

## DELETE\_LU\_POOL

### *fqplu\_name*

Fully qualified LU name for the partner LU, as defined to CS/AIX. The name is a 17-byte EBCDIC string, right-padded with EBCDIC spaces. It consists of a network ID of up to 8 A-string characters, an EBCDIC dot (period) character, and a network name of up to 8 A-string characters.

## Returned parameters: successful execution

If the verb executes successfully, CS/AIX returns the following parameters:

### *primary\_rc*

AP\_OK

## Returned parameters: parameter check

If the verb does not execute because of a parameter error, CS/AIX returns the following parameters:

### *primary\_rc*

AP\_PARAMETER\_CHECK

### *secondary\_rc*

#### **AP\_INVALID\_PLU\_NAME**

The *fqplu\_name* parameter was not valid.

#### **AP\_INVALID\_LU\_NAME**

The *lu\_name* parameter was not valid.

#### **AP\_INVALID\_LU\_ALIAS**

The *lu\_alias* parameter was not valid.

Appendix B, “Common return codes,” on page 661 lists further secondary return codes associated with AP\_PARAMETER\_CHECK, which are common to all NOF verbs.

## Returned parameters: other conditions

Appendix B, “Common return codes,” on page 661 lists further combinations of primary and secondary return codes that are common to all NOF verbs.

## DELETE\_LU\_POOL

---

DELETE\_LU\_POOL is used to do one of the following:

- Remove one or more LUs from a pool
- Remove all LUs from a pool and delete the pool

This verb does not delete the LUs; they remain defined, but are not associated with any pool.

## VCB structure

```
typedef struct delete_lu_pool
{
    AP_UINT16      opcode;          /* verb operation code      */
    unsigned char  reserv2;        /* reserved                  */
    unsigned char  format;        /* reserved                  */
    AP_UINT16      primary_rc;     /* primary return code      */
    AP_UINT32      secondary_rc;   /* secondary return code    */
    unsigned char  pool_name[8];   /* LU pool name             */
    AP_UINT16      num_lus;        /* Number of specified LUs  */
    unsigned char  lu_names[10][8]; /* LU names                  */
} DELETE_LU_POOL;
```

## Supplied parameters

The application supplies the following parameters:

**opcode**

AP\_DELETE\_LU\_POOL

**pool\_name**

Name of the LU pool. This is an 8-byte EBCDIC string, padded on the right with spaces if the name is shorter than 8 characters.

**num\_lus**

The number of LUs to be removed (the number of LU names in the *lu\_names* list). The range is 1-10 when removing LUs from a pool without deleting it. To remove all LUs from the pool and delete the pool, specify zero.

**lu\_names**

To remove one or more LUs from the pool without deleting the pool, specify the names of the LUs to be removed. The number of names specified must match the *num\_lus* parameter. Each name is an 8-byte type A EBCDIC string (starting with a letter), padded on the right with EBCDIC spaces if the name is shorter than 8 characters.

If *num\_lus* is set to zero, to remove all LUs from the pool and delete the pool, this parameter is not used.

**Returned parameters: successful execution**

If the verb executes successfully, CS/AIX returns the following parameters:

**primary\_rc**

AP\_OK

**Returned parameters: parameter check**

If the verb does not execute because of a parameter error, CS/AIX returns the following parameters:

**primary\_rc**

AP\_PARAMETER\_CHECK

**secondary\_rc**

Possible values are:

**AP\_INVALID\_POOL\_NAME**

The supplied pool name was not valid.

**AP\_INVALID\_LU\_NAME**

One or more of the specified LU names did not match the name of an LU in the pool.

**AP\_INVALID\_NUM\_LUS**

The supplied *num\_lus* parameter was not in the valid range.

**Returned parameters: other conditions**

Appendix B, “Common return codes,” on [page 661](#) lists further combinations of primary and secondary return codes that are common to all NOF verbs.

**DELETE\_MODE**

DELETE\_MODE deletes the definition of a mode. You cannot delete SNA-defined modes such as SNASVCMG and CPSVCMG.

**VCB structure**

```
typedef struct delete_mode
{
    AP_UINT16      opcode;          /* verb operation code          */
    unsigned char  reserv2;        /* reserved                     */
    unsigned char  format;         /* reserved                     */
    AP_UINT16      primary_rc;     /* primary return code         */
}
```

## DELETE\_PARTNER\_LU

```
    AP_UINT32      secondary_rc;    /* secondary return code    */
    unsigned char  mode_name[8];   /* mode name                 */
} DELETE_MODE;
```

### Supplied parameters

The application supplies the following parameters:

#### *opcode*

AP\_DELETE\_MODE

#### *mode\_name*

Name of the mode. This is an 8-byte type-A EBCDIC string (starting with a letter), padded on the right with EBCDIC spaces if the name is shorter than 8 characters.

### Returned parameters: successful execution

If the verb executes successfully, CS/AIX returns the following parameters:

#### *primary\_rc*

AP\_OK

### Returned parameters: parameter check

If the verb does not execute because of a parameter error, CS/AIX returns the following parameters:

#### *primary\_rc*

AP\_PARAMETER\_CHECK

#### *secondary\_rc*

Possible values are:

##### **AP\_CP\_OR\_SNA\_SVCMG\_UNDELETABLE**

The specified mode name is one of the SNA-defined mode names, and cannot be deleted.

##### **AP\_MODE\_NAME\_NOT\_DEFD**

The specified mode name is not the name of a mode defined on the CS/AIX system.

##### **AP\_DEL\_MODE\_DEFAULT\_SPCD**

The specified mode was defined as the default mode using the DEFINE\_DEFAULTS verb, so it cannot be deleted.

##### **AP\_MODE\_UNDELETABLE**

The specified mode name is one of the SNA-defined mode names, and cannot be deleted.

Appendix B, “Common return codes,” on page 661 lists further secondary return codes associated with AP\_PARAMETER\_CHECK, which are common to all NOF verbs.

### Returned parameters: other conditions

Appendix B, “Common return codes,” on page 661 lists further combinations of primary and secondary return codes that are common to all NOF verbs.

## DELETE\_PARTNER\_LU

The DELETE\_PARTNER\_LU verb deletes a partner LU definition.

### VCB structure

```
typedef struct delete_partner_lu
{
    AP_UINT16      opcode;          /* verb operation code      */
    unsigned char  reserv2;        /* reserved                  */
    unsigned char  format;         /* reserved                  */
    AP_UINT16      primary_rc;     /* primary return code      */
    AP_UINT32      secondary_rc;   /* secondary return code    */
}
```

```

    unsigned char    fqplu_name[17];    /* fully qualified partner LU name */
} DELETE_PARTNER_LU;

```

## Supplied parameters

The application supplies the following parameters:

### ***opcode***

AP\_DELETE\_PARTNER\_LU

### ***fqplu\_name***

Fully qualified LU name for the partner LU to be deleted. The name is a 17-byte EBCDIC string, right-padded with EBCDIC spaces. It consists of a network ID of up to 8 A-string characters, an EBCDIC dot (period) character, and a network name of up to 8 A-string characters.

## Returned parameters: successful execution

If the verb executes successfully, CS/AIX returns the following parameters:

### ***primary\_rc***

AP\_OK

## Returned parameters: parameter check

If the verb does not execute because of a parameter error, CS/AIX returns the following parameters:

### ***primary\_rc***

AP\_PARAMETER\_CHECK

### ***secondary\_rc***

#### **AP\_INVALID\_PLU\_NAME**

The supplied *fqplu\_name* parameter did not match any defined partner LU name.

Appendix B, “Common return codes,” on page 661 lists further secondary return codes associated with AP\_PARAMETER\_CHECK, which are common to all NOF verbs.

## Returned parameters: other conditions

Appendix B, “Common return codes,” on page 661 lists further combinations of primary and secondary return codes that are common to all NOF verbs.

## DELETE\_PORT

DELETE\_PORT deletes a port. This verb also deletes the following:

- All link stations and connection network TGs associated with the port.
- All PUs associated with LSs on the port, all LUs owned by these PUs, and all LU-LU passwords associated with these LUs.

The port must be inactive when the verb is issued.

## VCB structure

```

typedef struct delete_port
{
    AP_UINT16    opcode;                /* verb operation code          */
    unsigned char    reserv2;           /* reserved                      */
    unsigned char    format;           /* reserved                      */
    AP_UINT16    primary_rc;           /* primary return code          */
    AP_UINT32    secondary_rc;         /* secondary return code        */
    unsigned char    port_name[8];     /* name of port                 */
} DELETE_PORT;

```

## DELETE\_RCF\_ACCESS

### Supplied parameters

The application supplies the following parameters:

***opcode***

AP\_DELETE\_PORT

***port\_name***

Name of port being deleted. This is an 8-byte ASCII string, right-padded with spaces if the name is shorter than 8 characters.

### Returned parameters: successful execution

If the verb executes successfully, CS/AIX returns the following parameters:

***primary\_rc***

AP\_OK

### Returned parameters: parameter check

If the verb does not execute because of a parameter error, CS/AIX returns the following parameters:

***primary\_rc***

AP\_PARAMETER\_CHECK

***secondary\_rc***

**AP\_INVALID\_PORT\_NAME**

The specified port name was not the name of a port defined on the CS/AIX system.

Appendix B, “Common return codes,” on page 661 lists further secondary return codes associated with AP\_PARAMETER\_CHECK, which are common to all NOF verbs.

### Returned parameters: state check

If the verb does not execute because of a state error, CS/AIX returns the following parameters.

***primary\_rc***

AP\_STATE\_CHECK

***secondary\_rc***

**AP\_PORT\_ACTIVE**

The specified port cannot be deleted because it is currently active.

Appendix B, “Common return codes,” on page 661 lists further secondary return codes associated with AP\_STATE\_CHECK, which are common to all NOF verbs.

### Returned parameters: other conditions

Appendix B, “Common return codes,” on page 661 lists further combinations of primary and secondary return codes that are common to all NOF verbs.

## DELETE\_RCF\_ACCESS

---

DELETE\_RCF\_ACCESS prevents access to the CS/AIX Remote Command Facility (RCF), which was previously specified using DEFINE\_RCF\_ACCESS. For more information about RCF, see the *IBM Communications Server for Data Center Deployment on AIX Administration Guide*.

This verb prevents access to both SPCF and UCF. To allow access to one of them but prevent access to the other, use DEFINE\_RCF\_ACCESS.

This verb must be issued to the domain configuration file. CS/AIX acts on the RCF access parameters during node startup; if RCF access is deleted while a node is running, the change does not take effect on the server where the node is running until the node is stopped and restarted.



## VCB structure

```
typedef struct delete_rcf_access
{
    AP_UINT16      opcode;           /* Verb operation code      */
    unsigned char  reserv2;         /* reserved                 */
    unsigned char  format;         /* reserved                 */
    AP_UINT16      primary_rc;     /* primary return code     */
    AP_UINT32      secondary_rc;   /* secondary return code   */
} DELETE_RCF_ACCESS;
```

## Supplied parameters

The application supplies the following parameter:

### *opcode*

AP\_DELETE\_RCF\_ACCESS

## Returned parameters: successful execution

If the verb executes successfully, CS/AIX returns the following parameters:

### *primary\_rc*

AP\_OK

## Returned parameters: other conditions

Appendix B, “Common return codes,” on page 661 lists further combinations of primary and secondary return codes that are common to all NOF verbs.

## DELETE\_SECURITY\_ACCESS\_LIST

---

DELETE\_SECURITY\_ACCESS\_LIST is used to do one of the following:

- Delete a security access list.
- Delete one or more users from a security access list but leave the list configured.

You can delete a user name from the security access list regardless of whether there are active conversations that were set up using that user name. Deleting the user name does not affect the active conversations, but the invoking program will not be able to set up any further conversations using the deleted user name.

## VCB structure

The DELETE\_SECURITY\_ACCESS\_LIST verb contains a variable number of `security_user_name` structures; these define the user names to be deleted from the security access list. The user name structures are included at the end of the `delete_security_access_list` structure; the number of these structures is specified by the `num_users` parameter.

```
typedef struct delete_security_access_list
{
    AP_UINT16      opcode;           /* verb operation code      */
    unsigned char  reserv2;         /* reserved                 */
    unsigned char  format;         /* reserved                 */
    AP_UINT16      primary_rc;     /* primary return code     */
    AP_UINT32      secondary_rc;   /* secondary return code   */
    unsigned char  list_name[14];  /* name of this list       */
    unsigned char  reserv3[2];     /* reserved                 */
    AP_UINT32      num_users;      /* number of users to delete */
} DELETE_SECURITY_ACCESS_LIST;
```

```
typedef struct security_user_name
{
```

## DELETE\_TN3270\_ACCESS

```
unsigned char    user_name[10];          /* user name to delete      */
} SECURITY_USER_NAME;
```

### Supplied parameters

The application supplies the following parameters:

#### ***opcode***

AP\_DELETE\_SECURITY\_ACCESS\_LIST

#### ***list\_name***

The name of the security access list being deleted, or the list from which user names are being deleted. This is an ASCII string of 1-14 characters, padded on the right with spaces if the name is shorter than 14 characters, which must match a previously-defined security access list name.

#### ***num\_users***

The number of user names to be deleted from the security access list, as follows:

- To delete one or more user names from the list but leave other user names configured, specify the number of user names that are being deleted. Each of these must be defined by a user name structure, as described below.
- To delete the entire security access list, specify zero in this parameter and do not include any user names.

For each user name to be deleted, up to the number specified in *num\_users*, append a SECURITY\_USER\_NAME structure to the end of the DELETE\_SECURITY\_ACCESS\_LIST structure, containing the following parameter:

#### ***user\_name***

The user name being deleted. This must match a user name that is currently defined for this security access list.

### Returned parameters: successful execution

If the verb executes successfully, CS/AIX returns the following parameters:

#### ***primary\_rc***

AP\_OK

### Returned parameters: parameter check

If the verb does not execute because of a parameter error, CS/AIX returns the following parameters:

#### ***primary\_rc***

AP\_PARAMETER\_CHECK

#### ***secondary\_rc***

Possible values are:

##### **AP\_INVALID\_LIST\_NAME**

The specified security access list name was not defined as a security access list name.

##### **AP\_INVALID\_USER\_NAME**

One or more of the specified user names did not match the name of a user defined for this security access list.

### Returned parameters: other conditions

Appendix B, “Common return codes,” on [page 661](#) lists further combinations of primary and secondary return codes that are common to all NOF verbs.

## DELETE\_TN3270\_ACCESS

---

DELETE\_TN3270\_ACCESS is used to do one of the following:

- Delete a TN3270 Server user, so that this user can no longer use TN server to access a host.
- Delete one or more of the user's sessions but leave the user configured.

## VCB structure

```
typedef struct delete_tn3270_access
{
    AP_UINT16      opcode;                /* verb operation code          */
    unsigned char  reserv2;              /* reserved                      */
    unsigned char  format;               /* reserved                      */
    AP_UINT16      primary_rc;           /* primary return code          */
    AP_UINT32      secondary_rc;        /* secondary return code        */
    AP_UINT16      default_record;      /* is this the DEFAULT record?  */
    unsigned char  client_address[256]; /* address of TN3270 user       */
    AP_UINT32      num_sessions;        /* number of sessions to delete */
    unsigned char  delete_options;      /* delete all sessions / delete */
                                        /* user?                         */
} DELETE_TN3270_ACCESS;
```

```
typedef struct tn3270_session_name
{
    AP_UINT16      port_number;          /* TCP/IP port num of session   */
                                        /* to delete                    */
    unsigned char  listen_local_address[46]; /* Local addr client connects to */
} TN3270_SESSION_NAME;
```

## Supplied parameters

The application supplies the following parameters:

### **opcode**

AP\_DELETE\_TN3270\_ACCESS

### **default\_record**

Specifies whether this verb refers to the default TN3270 user record that is used by any TN3270 user not explicitly identified by a TCP/IP address (deleting this record means that such users cannot access TN server). Possible values are:

#### **AP\_YES**

This verb refers to the default TN3270 user record. The *client\_address* parameter is reserved.

#### **AP\_NO**

This verb refers to a normal TN3270 user record.

### **client\_address**

The TCP/IP address of the TN3270 user to be deleted, as specified on the DEFINE\_TN3270\_ACCESS verb. This is a null-terminated ASCII string, which can be any of the following.

- An IPv4 dotted-decimal address (such as 193.1.11.100).
- An IPv6 colon-hexadecimal address (such as 2001:0db8:0000:0000:0000:0000:1428:57ab or 2001:db8::1428:57ab).
- A name (such as newbox.this.co.uk).
- An alias (such as newbox).

### **num\_sessions**

The number of sessions to be deleted, as follows:

- To delete one or more of the user's sessions but leave other sessions configured, specify the number of sessions that are being deleted. Each of these must be defined by its TCP/IP port number, as described below.
- To delete all sessions, or to delete the user, specify zero in this parameter and do not include any TCP/IP port numbers. Specify the type of deletion required in the *delete\_options* parameter below.

## DELETE\_TN3270\_ASSOCIATION

### *delete\_options*

If the *num\_sessions* parameter (see above) is nonzero, this parameter is ignored. If *num\_sessions* is zero, specify one of the following values:

#### **AP\_ALL\_SESSIONS**

Delete all sessions but leave the TN3270 user configured.

#### **AP\_DELETE\_USER**

Delete the user and all the user's sessions.

For each session to be deleted, up to the number specified in *num\_sessions*, append a TN3270\_SESSION\_NAME structure to the end of the DELETE\_TN3270\_ACCESS structure, containing the following parameters:

#### ***tn3270\_session\_name.port\_number***

The TCP/IP port number used for the session. This must match a port number defined for this TN3270 user.

#### ***tn3270\_session\_name.listen\_local\_address***

The address on the local TN Server computer to which TN3270 clients connect.

- If this parameter was not specified when configuring the session, specify it as all binary zeros.
- If the address was specified when configuring the session, specify the same address in this parameter.

## Returned parameters: successful execution

If the verb executes successfully, CS/AIX returns the following parameters:

### ***primary\_rc***

AP\_OK

## Returned parameters: parameter check

If the verb does not execute because of a parameter error, CS/AIX returns the following parameters:

### ***primary\_rc***

AP\_PARAMETER\_CHECK

### ***secondary\_rc***

Possible values are:

#### **AP\_INVALID\_CLIENT\_ADDRESS**

The specified client address did not match the TCP/IP address defined for any TN3270 user.

#### **AP\_INVALID\_PORT\_NUMBER**

The specified TCP/IP port number did not match any TCP/IP port number defined for this user.

Appendix B, "Common return codes," on page 661 lists further secondary return codes associated with AP\_PARAMETER\_CHECK, which are common to all NOF verbs.

## Returned parameters: other conditions

Appendix B, "Common return codes," on page 661 lists further combinations of primary and secondary return codes that are common to all NOF verbs.

## DELETE\_TN3270\_ASSOCIATION

---

DELETE\_TN3270\_ASSOCIATION deletes an association between a display LU and a printer LU, given the display LU name.

## VCB structure

```
typedef struct delete_tn3270_association
{
    AP_UINT16      opcode;          /* verb operation code          */
    unsigned char  reserv2;        /* reserved                      */
    unsigned char  format;         /* reserved                      */
    AP_UINT16      primary_rc;     /* primary return code          */
    AP_UINT32      secondary_rc;   /* secondary return code        */
    unsigned char  display_lu_name[8]; /* Display LU name              */
} DELETE_TN3270_ASSOCIATION;
```

## Supplied parameters

The application supplies the following parameters:

### *opcode*

AP\_DELETE\_TN3270\_ASSOCIATION

### *display\_lu\_name*

Specifies the name of the display LU whose association is to be deleted. This is an EBCDIC string padded on the right with EBCDIC spaces.

## Returned parameters: successful execution

If the verb executes successfully, CS/AIX returns the following parameters:

### *primary\_rc*

AP\_OK

## Returned parameters: parameter check

If the verb does not execute because of a parameter error, CS/AIX returns the following parameters:

### *primary\_rc*

AP\_PARAMETER\_CHECK

### *secondary\_rc*

**AP\_INVALID\_LU\_NAME**

The display LU name was not a valid EBCDIC string.

Appendix B, “Common return codes,” on page 661 lists further secondary return codes associated with AP\_PARAMETER\_CHECK, which are common to all NOF verbs.

## Returned parameters: state check

If the verb does not execute because of a state error, CS/AIX returns the following parameters.

### *primary\_rc*

AP\_STATE\_CHECK

### *secondary\_rc*

**AP\_INVALID\_LU\_NAME**

No association is defined for the specified display LU.

Appendix B, “Common return codes,” on page 661 lists further secondary return codes associated with AP\_PARAMETER\_CHECK, which are common to all NOF verbs.

## Returned parameters: other conditions

Appendix B, “Common return codes,” on page 661 lists further combinations of primary and secondary return codes that are common to all NOF verbs.

## DELETE\_TN\_REDIRECT

DELETE\_TN\_REDIRECT is used to delete a TN Redirector user, so that this user can no longer use TN Redirector to access a host.

### VCB structure

```
typedef struct delete_tn_redirect
{
    AP_UINT16      opcode;           /* verb operation code          */
    unsigned char  reserv2;         /* reserved                     */
    unsigned char  format;         /* reserved                     */
    AP_UINT16      primary_rc;     /* primary return code         */
    AP_UINT32      secondary_rc;   /* secondary return code       */
    TN_REDIRECT_ADDRESS addr;      /* Uniquely defines record     */
} DELETE_TN_REDIRECT;
```

```
typedef struct tn_redirect_address
{
    AP_UINT16      default_record;  /* Is this the default record ? */
    unsigned char  address_format; /* IP address or fully-qualified name */
    unsigned char  client_address[256]; /* Client address                */
    AP_UINT16      port_number;     /* Port number that client connects on */
    unsigned char  listen_local_address[46]; /* Local addr client connects to */
    unsigned char  reserved[34];    /* reserved                      */
} TN_REDIRECT_ADDRESS;
```

### Supplied parameters

The application supplies the following parameters:

#### **opcode**

AP\_DELETE\_TN\_REDIRECT

#### **addr.default\_record**

Specifies whether this verb refers to the default TN Redirector user record that is used by any TN Redirector user not explicitly identified by a TCP/IP address (deleting this record means that such users cannot access TN Redirector). Possible values are:

##### **AP\_YES**

This verb refers to a default record. The *client\_address* and *address\_format* parameters are reserved.

##### **AP\_NO**

This verb refers to a normal TN Redirector user record.

#### **addr.address\_format**

Specifies the format of the *client\_address* parameter. Possible values are:

##### **AP\_ADDRESS\_IP**

IP address (either IPv4 or IPv6)

##### **AP\_ADDRESS\_FQN**

Alias or fully qualified name

#### **addr.client\_address**

The TCP/IP address of the computer on which the Telnet client runs. This is a null-terminated ASCII string, which can be any of the following; the *address\_format* parameter indicates whether it is an IP address or a name.

- An IPv4 dotted-decimal address (such as 193.1.11.100).
- An IPv6 colon-hexadecimal address (such as 2001:0db8:0000:0000:0000:0000:1428:57ab or 2001:db8::1428:57ab).
- A name (such as newbox.this.co.uk).
- An alias (such as newbox).

If you use a name or alias, the AIX system must be able to resolve the name or alias to a fully qualified name (either using the local TCP/IP configuration or using a Domain Name server).

***addr.port\_number***

The number of the server TCP/IP port that the Telnet client uses to access the TN server node.

***addr.listen\_local\_address***

The address on the local TN Server computer to which TN3270 clients connect.

- If this parameter was not specified when configuring the TN redirection record, specify it as all binary zeros.
- If the address was specified when configuring the TN redirection record, specify the same address in this parameter.

## Returned parameters: successful execution

If the verb executes successfully, CS/AIX returns the following parameters:

***primary\_rc***

AP\_OK

## Returned parameters: parameter check

If the verb does not execute because of a parameter error, CS/AIX returns the following parameters:

***primary\_rc***

AP\_PARAMETER\_CHECK

***secondary\_rc***

**AP\_INVALID\_CLIENT\_ADDRESS**

The specified addressing information did not match any defined TN Redirector user.

Appendix B, “Common return codes,” on page 661 lists further secondary return codes associated with AP\_PARAMETER\_CHECK, which are common to all NOF verbs.

## Returned parameters: other conditions

Appendix B, “Common return codes,” on page 661 lists further combinations of primary and secondary return codes that are common to all NOF verbs.

## DELETE\_TP

---

DELETE\_TP deletes a TP definition.

## VCB structure

```
typedef struct delete_tp
{
    AP_UINT16      opcode;                /* verb operation code      */
    unsigned char  reserv2;              /* reserved                  */
    unsigned char  format;               /* reserved                  */
    AP_UINT16      primary_rc;           /* primary return code      */
    AP_UINT32      secondary_rc;         /* secondary return code    */
    unsigned char  tp_name[64];         /* TP name                   */
} DELETE_TP;
```

## Supplied parameters

The application supplies the following parameters:

***opcode***

AP\_DELETE\_TP

## DELETE\_TP\_LOAD\_INFO

### *tp\_name*

Name of the TP to be deleted.

## Returned parameters: successful execution

If the verb executes successfully, CS/AIX returns the following parameters:

### *primary\_rc*

AP\_OK

## Returned parameters: parameter check

If the verb does not execute because of a parameter error, CS/AIX returns the following parameters:

### *primary\_rc*

AP\_PARAMETER\_CHECK

### *secondary\_rc*

Possible values are:

#### **AP\_INVALID\_TP\_NAME**

The *tp\_name* parameter did not match the name of a defined TP.

#### **AP\_SYSTEM\_TP\_CANT\_BE\_DELETED**

The specified TP name is the name of a TP used internally by CS/AIX you cannot delete it.

Appendix B, “Common return codes,” on page 661 lists further secondary return codes associated with AP\_PARAMETER\_CHECK, which are common to all NOF verbs.

## Returned parameters: other conditions

Appendix B, “Common return codes,” on page 661 lists further combinations of primary and secondary return codes that are common to all NOF verbs.

## DELETE\_TP\_LOAD\_INFO

---

The DELETE\_TP\_LOAD\_INFO verb deletes a TP load information entry.

## VCB structure

```
typedef struct delete_tp_load_info
{
    AP_UINT16          opcode;                /* verb operation code      */
    unsigned char     reserv2;               /* reserved                  */
    unsigned char     format;               /* reserved                  */
    AP_UINT16          primary_rc;          /* primary return code      */
    AP_UINT32          secondary_rc;       /* secondary return code    */
    unsigned char     tp_name[64];         /* TP name                   */
    unsigned char     lu_alias[8];        /* LU alias                  */
} DELETE_TP_LOAD_INFO;
```

## Supplied parameters

The application supplies the following parameters:

### *opcode*

AP\_DELETE\_TP\_LOAD\_INFO

### *tp\_name*

The TP name of the TP load info entry to be deleted. This is a 64-byte EBCDIC string, padded on the right with spaces if the name is shorter than 64 characters.

### *lu\_alias*

The LU alias of the TP load info entry to be deleted. This is an 8-byte ASCII string, padded on the right with spaces if the name is shorter than 8 bytes.



This parameter can be used only if the TP is an APPC application; it is reserved if the TP is a CPI-C application.

## Returned parameters: successful execution

If the verb executes successfully, CS/AIX returns the following parameters:

**primary\_rc**  
AP\_OK

## Returned parameters: parameter check

If the verb does not execute because of a parameter error, CS/AIX returns the following parameters:

**primary\_rc**  
AP\_PARAMETER\_CHECK

**secondary\_rc**  
Possible values are:

**AP\_INVALID\_TP\_NAME**  
The *tp\_name* parameter did not match the name of a defined TP.

**AP\_INVALID\_LU\_ALIAS**  
The *lu\_alias* parameter did not match any defined LU alias specified for a TP load info entry for the TP name specified.

Appendix B, “Common return codes,” on page 661 lists further secondary return codes associated with AP\_PARAMETER\_CHECK, which are common to all NOF verbs.

## Returned parameters: other conditions

Appendix B, “Common return codes,” on page 661 lists further combinations of primary and secondary return codes that are common to all NOF verbs.

## DELETE\_USERID\_PASSWORD

DELETE\_USERID\_PASSWORD deletes a password associated with a user ID, or removes profiles for a user ID and password.

## VCB structure

```
typedef struct delete_userid_password
{
    AP_UINT16          opcode;           /* verb operation code      */
    unsigned char     reserv2;          /* reserved                 */
    unsigned char     format;           /* reserved                 */
    AP_UINT16          primary_rc;      /* primary return code      */
    AP_UINT32          secondary_rc;    /* secondary return code    */
    AP_UINT16          delete_type;     /* type of delete           */
    unsigned char     user_id[10];      /* user id                  */
    USERID_PASSWORD_CHARS password_chars; /* password characteristics */
} DELETE_USERID_PASSWORD;
```

```
typedef struct userid_password_chars
{
    unsigned char     description[32];   /* resource description     */
    unsigned char     reserv2[16];      /* reserved                 */
    AP_UINT16          profile_count;    /* number of profiles      */
    AP_UINT16          reserv1;         /* reserved                 */
    unsigned char     password[10];     /* password                 */
    unsigned char     profiles[10][10]; /* profiles                 */
} USERID_PASSWORD_CHARS;
```

## Supplied parameters

The application supplies the following parameters:

***opcode***

AP\_DELETE\_USERID\_PASSWORD

***delete\_type***

Specifies how this verb is being used. Possible values are:

**AP\_REMOVE\_USER**

Delete the user, password, and all associated profiles.

**AP\_REMOVE\_PROFILES**

Delete the specified profiles.

***user\_id***

User identifier. This is a 10-byte type-AE EBCDIC character string, padded on the right with EBCDIC spaces if the name is shorter than 10 characters.

***password\_chars.description***

This parameter is ignored.

***password\_chars.profile\_count***

Number of profiles to be deleted. If *delete\_type* is set to AP\_REMOVE\_USER, this parameter is reserved.

***password\_chars.password***

This parameter is ignored.

***password\_chars.profiles***

Profiles associated with user. Each of these is a 10-byte type-AE EBCDIC character string, padded on the right with EBCDIC spaces if the profile name is shorter than 10 characters.

## Returned parameters: successful execution

If the verb executes successfully, CS/AIX returns the following parameters:

***primary\_rc***

AP\_OK

## Returned parameters: parameter check

If the verb does not execute because of a parameter error, CS/AIX returns the following parameters:

***primary\_rc***

AP\_PARAMETER\_CHECK

***secondary\_rc***

Possible values are:

**AP\_NO\_PROFILES**

The *delete\_type* parameter was set to AP\_REMOVE\_PROFILES, but no profiles were specified.

**AP\_UNKNOWN\_USER**

The *user\_id* parameter did not match a defined user ID.

**AP\_INVALID\_UPDATE\_TYPE**

The *delete\_type* parameter was not set to a valid value.

Appendix B, “Common return codes,” on page 661 lists further secondary return codes associated with AP\_PARAMETER\_CHECK, which are common to all NOF verbs.

## Returned parameters: other conditions

Appendix B, “Common return codes,” on page 661 lists further combinations of primary and secondary return codes that are common to all NOF verbs.

## DISCONNECT\_NODE

An application uses this verb to release its handle to a CS/AIX node when it has finished issuing NOF verbs to the node. The node from which the application wishes to disconnect is identified by the *target\_handle* parameter on the call. After the verb completes successfully, the target handle identifying the node is no longer valid.

The application should always issue DISCONNECT\_NODE for any open node handles before it exits, to allow CS/AIX to free the resources associated with the application.

This verb may be issued to release a target handle for a running node, or for a server where the node is not running.

### VCB structure

```
typedef struct disconnect_node
{
    AP_UINT16      opcode;          /* Verb operation code      */
    unsigned char  reserv2;        /* reserved                  */
    unsigned char  format;        /* reserved                  */
    AP_UINT16      primary_rc;     /* Primary return code      */
    AP_UINT32      secondary_rc;   /* Secondary return code    */
} DISCONNECT_NODE;
```

### Supplied parameters

#### *opcode*

AP\_DISCONNECT\_NODE

### Returned parameters: successful execution

If the verb executes successfully, CS/AIX returns the following parameters:

#### *primary\_rc*

AP\_OK

#### *secondary\_rc*

Not used.

### Returned parameters: state check

If the verb does not execute because of a state check, CS/AIX returns the following parameters:

#### *primary\_rc*

AP\_STATE\_CHECK

#### *secondary\_rc*

##### **AP\_VERB\_IN\_PROGRESS**

The specified target handle cannot be released because a previous verb issued for this handle is still outstanding. All verbs for the target handle must be completed before attempting to disconnect from the node.

[Appendix B, “Common return codes,” on page 661](#) lists further secondary return codes associated with AP\_STATE\_CHECK, which are common to all NOF verbs.

### Returned parameters: other conditions

[Appendix B, “Common return codes,” on page 661](#) lists further combinations of primary and secondary return codes that are common to all NOF verbs.

## INIT\_NODE

---

This verb starts a previously-defined node. The application must first issue CONNECT\_NODE to obtain a target handle for the node; it then uses this target handle on the INIT\_NODE call to identify the node to start.

This verb must be issued to a server where the node is not running.

### VCB structure

```
typedef struct init_node
{
    AP_UINT16          opcode;           /* verb operation code      */
    unsigned char     reserv2;         /* reserved                 */
    unsigned char     format;         /* reserved                 */
    AP_UINT16          primary_rc;     /* primary return code     */
    AP_UINT32          secondary_rc;   /* secondary return code   */
} INIT_NODE;
```

### Supplied parameters

The application supplies the following parameters:

#### *opcode*

AP\_INIT\_NODE

### Returned parameters: successful execution

If the verb executes successfully, CS/AIX returns the following parameters:

#### *primary\_rc*

AP\_OK

#### *secondary\_rc*

Not used.

### Returned parameters: parameter check

If the verb does not execute because of a parameter check, CS/AIX returns the following parameters:

#### *primary\_rc*

AP\_PARAMETER\_CHECK

#### *secondary\_rc*

Possible values are:

##### **AP\_INVALID\_NODE\_NAME**

The node name specified in the configuration file does not match the name of the CS/AIX computer to which the verb was issued.

##### **AP\_NOT\_SERVER**

The node name specified in the configuration file matches the name of the CS/AIX computer, but the specified computer is a client (not a server) and cannot run the node.

##### **AP\_DLUR\_NOT\_SUPPORTED**

The configuration of the node specifies that DLUR is supported, but the node is defined as a LEN node. DLUR cannot be supported on a LEN node.

### Returned parameters: state check

If the verb does not execute because of a state check, CS/AIX returns the following parameters.

#### *primary\_rc*

AP\_STATE\_CHECK

**secondary\_rc**

Possible values are:

**AP\_NODE\_ALREADY\_STARTED**

The specified node has already been started.

**AP\_RESOURCE\_NOT\_LOADED**

The node was not started because CS/AIX detected one or more errors while attempting to load its configuration. Check the error log file for messages giving more details of the errors.

**AP\_INVALID\_VERSION**

The node was not started because there was a version mismatch between components of the CS/AIX software. If you have upgraded your CS/AIX license to include additional functions or users, check that you are using the correct version of the licensing software.

Appendix B, “Common return codes,” on page 661 lists further secondary return codes associated with AP\_STATE\_CHECK, which are common to all NOF verbs.

**Returned parameters: other conditions**

Appendix B, “Common return codes,” on page 661 lists further combinations of primary and secondary return codes that are common to all NOF verbs.

**INITIALIZE\_SESSION\_LIMIT**

The INITIALIZE\_SESSION\_LIMIT verb initializes the session limits for a combination of local LU, partner LU, and mode.

You must issue this verb before you issue an ACTIVATE\_SESSION verb.

This verb can be issued from a NOF application running on a client. If it runs on an AIX or Linux client, the NOF application must run with the userid root, or with a userid that is a member of the sys group (AIX) or sna group (Linux).

**VCB structure**

```
typedef struct initialize_session_limit
{
    AP_UINT16      opcode;                /* verb operation code      */
    unsigned char  reserv2;               /* reserved                  */
    unsigned char  format;                /* reserved                  */
    AP_UINT16      primary_rc;            /* primary return code      */
    AP_UINT32      secondary_rc;          /* secondary return code    */
    unsigned char  lu_name[8];            /* local LU name            */
    unsigned char  lu_alias[8];           /* local LU alias           */
    unsigned char  plu_alias[8];          /* partner                   */
    unsigned char  fqplu_name[17];        /* fully qualified partner  */
    unsigned char  LU_name;                /* LU name                   */
    unsigned char  reserv3;               /* reserved                  */
    unsigned char  mode_name[8];          /* mode name                 */
    unsigned char  reserv3a;              /* reserved                  */
    unsigned char  set_negotiable;         /* set max negotiable limit? */
    AP_UINT16      plu_mode_session_limit; /* session limit            */
    AP_UINT16      min_conwinners_source; /* minimum source contention */
    AP_UINT16      min_conwinners_target; /* minimum target contention */
    AP_UINT16      auto_act;              /* auto activation limit    */
    unsigned char  reserv4[4];            /* reserved                  */
    AP_UINT32      sense_data;            /* sense data                */
} INITIALIZE_SESSION_LIMIT;
```

**Supplied parameters**

The application supplies the following parameters:

**opcode**

AP\_INITIALIZE\_SESSION\_LIMIT

## INITIALIZE\_SESSION\_LIMIT

### ***lu\_name***

LU name of the local LU, as defined to CS/AIX. This is an 8-byte type-A EBCDIC string, padded on the right with spaces if the name is shorter than 8 bytes. To indicate that the LU is defined by its LU alias instead of its LU name, set this parameter to 8 binary zeros.

### ***lu\_alias***

LU alias of the local LU, as defined to CS/AIX. This is an 8-byte ASCII string, using any locally displayable characters, padded on the right with spaces if the name is shorter than 8 bytes. It is used only if *lu\_name* is set to zeros.

To indicate the LU associated with the CP (the default LU), set both *lu\_name* and *lu\_alias* to 8 binary zeros.

### ***plu\_alias***

LU alias of the partner LU. This is an 8-byte ASCII string, using any locally displayable characters, padded on the right with spaces if the name is shorter than 8 bytes. To indicate that the partner LU is defined by its fully qualified LU name instead of its LU alias, set this parameter to 8 binary zeros.

### ***fqplu\_name***

Fully qualified LU name for the partner LU, as defined to CS/AIX. This parameter is used only if the *plu\_alias* field is set to zeros; it is ignored if *plu\_alias* is specified.

The name is a 17-byte EBCDIC string, right-padded with EBCDIC spaces. It consists of a network ID of up to 8 A-string characters, an EBCDIC dot (period) character, and a network name of up to 8 A-string characters.

### ***mode\_name***

Name of the mode to be used by the LUs. This is an 8-byte alphanumeric type-A EBCDIC string (starting with a letter), padded on the right with EBCDIC spaces if the name is shorter than 8 bytes.

### ***set\_negotiable***

Specifies whether the maximum negotiable session limit for this mode, as defined by DEFINE\_MODE, should be modified. Possible values are:

#### **AP\_YES**

Use the value specified by *plu\_mode\_session\_limit* as the maximum negotiable session limit for this LU-LU-mode combination.

#### **AP\_NO**

Leave the maximum negotiable session limit as the value specified for the mode.

### ***plu\_mode\_session\_limit***

Requested total session limit for this LU-LU-mode combination: the maximum number of parallel sessions permitted between these two LUs using this mode. Specify a value in the range 1-32,767 (which must not exceed the session limit specified for the local LU on the DEFINE\_LOCAL\_LU verb). This value may be negotiated with the partner LU.

### ***min\_conwinners\_source***

Minimum number of sessions using this mode for which the local LU is the contention winner. Specify a value in the range 0-32,767. The sum of the *min\_conwinners\_source* and *min\_conwinners\_target* parameters must not exceed the *plu\_mode\_session\_limit* parameter.

### ***min\_conwinners\_target***

Minimum number of sessions using this mode for which the partner LU is the contention winner. Specify a value in the range 0-32,767. The sum of the *min\_conwinners\_source* and *min\_conwinners\_target* parameters must not exceed the *plu\_mode\_session\_limit* parameter.

### ***auto\_act***

Number of sessions to activate automatically. Specify a value in the range 0-32,767 (which must not exceed the *plu\_mode\_session\_limit* parameter or the session limit specified for the local LU on the DEFINE\_LOCAL\_LU verb). The actual number of automatically activated sessions is the minimum of this value and the negotiated minimum number of contention winner sessions for the local LU.

## Returned parameters: successful execution

If the verb executes successfully, CS/AIX returns the following parameters:

**primary\_rc**

AP\_OK

**secondary\_rc**

Possible values are:

**AP\_AS\_NEGOTIATED**

The session limits were initialized, but one or more values were negotiated by the partner LU.

**AP\_AS\_SPECIFIED**

The session limits were initialized as requested, without being negotiated by the partner LU.

## Returned parameters: parameter check

If the verb does not execute because of a parameter error, CS/AIX returns the following parameters:

**primary\_rc**

AP\_PARAMETER\_CHECK

**secondary\_rc**

Possible values are:

**AP\_EXCEEDS\_MAX\_ALLOWED**

The *plu\_mode\_session\_limit*, *min\_conwinners\_source*, *min\_conwinners\_target*, or *auto\_act* parameter was set to a value outside the valid range.

**AP\_CANT\_CHANGE\_TO\_ZERO**

The *plu\_mode\_session\_limit* parameter cannot be set to zero using this verb; use RESET\_SESSION\_LIMIT instead.

**AP\_INVALID\_LU\_ALIAS**

The *lu\_alias* parameter did not match any defined local LU alias.

**AP\_INVALID\_LU\_NAME**

The *lu\_name* parameter did not match any defined local LU name.

**AP\_INVALID\_MODE\_NAME**

The *mode\_name* parameter did not match any defined mode name.

**AP\_INVALID\_PLU\_NAME**

The *fqplu\_name* parameter did not match any defined partner LU name.

**AP\_INVALID\_SET\_NEGOTIABLE**

The *set\_negotiable* parameter was not set to a valid value.

Appendix B, “Common return codes,” on page 661 lists further secondary return codes associated with AP\_PARAMETER\_CHECK, which are common to all NOF verbs.

## Returned parameters: state check

If the verb does not execute because of a state error, CS/AIX returns the following parameters.

**primary\_rc**

AP\_STATE\_CHECK

**secondary\_rc**

**AP\_MODE\_NOT\_RESET**

One or more sessions are currently active for this LU-LU-mode combination. Use CHANGE\_SESSION\_LIMIT instead of INITIALIZE\_SESSION\_LIMIT to specify the limits.

Appendix B, “Common return codes,” on page 661 lists further secondary return codes associated with AP\_STATE\_CHECK, which are common to all NOF verbs.

## Returned parameters: session allocation error

If the verb does not execute because of a session allocation error, CS/AIX returns the following parameters:

### *primary\_rc*

AP\_ALLOCATION\_ERROR

### *secondary\_rc*

#### **AP\_ALLOCATION\_FAILURE\_NO\_RETRY**

A session could not be allocated because of a condition that requires corrective action. Check the *sense\_data* parameter and any logged messages to determine the reason for the failure, and take any action required. Do not attempt to retry the verb until the condition has been corrected.

### *sense\_data*

The SNA sense data associated with the allocation failure.

## Returned parameters: CNOS processing errors

If the verb does not execute because of an error, CS/AIX returns the following parameters.

### *primary\_rc*

#### **AP\_CONV\_FAILURE\_NO\_RETRY**

The session limits could not be initialized because of a condition that requires action (such as a configuration mismatch or a session protocol error). Check the CS/AIX log file for information about the error condition, and correct it before retrying this verb.

### *primary\_rc*

AP\_CNOS\_PARTNER\_LU\_REJECT

### *secondary\_rc*

#### **AP\_CNOS\_COMMAND\_RACE\_REJECT**

The verb failed because the specified mode was being accessed by another administration program (or internally by the CS/AIX software) for session activation or deactivation, or for session limit processing. The application should retry the verb, preferably after a timeout to allow the race condition to be cleared.

## Returned parameters: other conditions

Appendix B, “Common return codes,” on page 661 lists further combinations of primary and secondary return codes that are common to all NOF verbs.

## OPEN\_FILE

An application uses this verb to access the CS/AIX domain configuration file in order to manage domain resources, or to access the `sna.net` file in order to manage backup servers on the CS/AIX LAN.

This verb must be issued with a null target handle. If it completes successfully, CS/AIX returns a handle identifying the file, which the application can then use on other NOF verbs to indicate the target for the verb.

## VCB structure

```
typedef struct open_file
{
    AP_UINT16      opcode;           /* verb operation code          */
    unsigned char  reserv2;         /* reserved                     */
    unsigned char  format;         /* reserved                     */
    AP_UINT16      primary_rc;     /* primary return code          */
    AP_UINT32      secondary_rc;   /* secondary return code        */
    CONFIG_FILE    file_info;      /* definition of file requested */
    AP_UINT32      target_handle;  /* handle for subsequent verbs  */
}
```



```

    unsigned char    reserv3[4];          /* reserved          */
} OPEN_FILE;

typedef struct config_file
{
    unsigned char    requested_role;     /* config file requested */
    unsigned char    role_supplied;     /* config file returned  */
    unsigned char    system_name[128];   /* computer name where file
                                        /* located                */
    unsigned char    file_name[81];     /* file name            */
} CONFIG_FILE;

```

## Supplied parameters

The application supplies the following parameters:

### **opcode**

AP\_OPEN\_FILE

### **file\_info.requested\_role**

The type of file to be opened. Possible values are:

#### **AP\_CONTROLLER**

Open the controlling copy of the domain configuration file. This value must be used if the application intends to issue verbs that modify the configuration of domain resources.

#### **AP\_BACKUP**

Open the controlling copy of the domain configuration file if available, otherwise a backup copy. This value may be used if the application intends to issue only QUERY\_\* verbs; if it needs to modify the configuration, it must use AP\_CONTROLLER, because it will not be able to obtain write access to a backup configuration file.

#### **AP\_SNA\_NET**

Open the sna.net file on the controller server.

#### **AP\_TP\_LOAD\_INFO**

Open a connection to the file on the local machine that contains information about how to load transaction programs (TPs).

## Returned parameters: successful execution

If the verb executes successfully, CS/AIX returns the following parameters:

### **primary\_rc**

AP\_OK

### **target\_handle**

Returned value for use on subsequent verbs directed to this file.

### **file\_info.role\_supplied**

If *requested\_role* was set to AP\_BACKUP, this parameter indicates whether the file handle returned is for the controlling configuration file or a backup file. Possible values are:

#### **AP\_CONTROLLER**

Controlling configuration file.

#### **AP\_BACKUP**

Backup configuration file.

For all other values of *requested\_role*, this parameter is undefined.

### **file\_info.system\_name**

Name of the CS/AIX computer where the file is located.

### **file\_info.file\_name**

Name of the file. This parameter is an ASCII string of 1-80 characters, followed by a null (0x00) character.

### Returned parameters: parameter check

If the verb does not execute because of a parameter error, CS/AIX returns the following parameters:

**primary\_rc**

AP\_PARAMETER\_CHECK

**secondary\_rc**

Possible values are:

**AP\_INVALID\_FILE\_NAME**

The *file\_name* parameter did not specify a valid configuration file name.

**AP\_INVALID\_FILE\_INFO**

One of the parameters in the *file\_info* structure was not valid.

Appendix B, “Common return codes,” on page 661 lists further secondary return codes associated with AP\_PARAMETER\_CHECK, which are common to all NOF verbs.

### Returned parameters: state check

If the verb does not execute because of a state error, CS/AIX returns the following parameters.

**primary\_rc**

AP\_STATE\_CHECK

**secondary\_rc**

Possible values are:

**AP\_CONNECTION\_NOT\_MADE**

CS/AIX could not set up the local communications path to the file.

**AP\_FILE\_BAD\_RECORD**

CS/AIX detected an error in the configuration file. Check the error log file for a message giving more details of the error.

**AP\_FILE\_ROLE\_UNAVAILABLE**

The application requested a controlling or backup configuration file, or the *sna.net* file, but no controller or backup server was available. This is normally a temporary condition, occurring when a new server is taking over as controller.

If the application is registered to receive server indications, it can check the *flags* parameter on these indications to determine when a new server has successfully taken over as controller, and then retry the OPEN\_FILE verb. For more information, see “SERVER\_INDICATION” on page 644. Alternatively, it can simply retry OPEN\_FILE at intervals until it succeeds.

**AP\_INVALID\_VERSION**

The CS/AIX version number in the configuration file header does not match the version of the CS/AIX software you are using. Check that you have the correct file.

Appendix B, “Common return codes,” on page 661 lists further secondary return codes associated with AP\_STATE\_CHECK, which are common to all NOF verbs.

### Returned parameters: other conditions

Appendix B, “Common return codes,” on page 661 lists further combinations of primary and secondary return codes that are common to all NOF verbs.

## PATH\_SWITCH

---

PATH\_SWITCH requests that CS/AIX switch a currently active Rapid Transport Protocol (RTP) connection to another path. If CS/AIX cannot find a better path, it leaves the connection unchanged.

## VCB structure

```
typedef struct path_switch
{
    AP_UINT16      opcode;           /* verb operation code      */
    unsigned char  reserv2;         /* reserved                  */
    unsigned char  format;          /* reserved                  */
    AP_UINT16      primary_rc;      /* primary return code      */
    AP_UINT32      secondary_rc;    /* secondary return code    */
    unsigned char  rtp_connection_name[8]; /* RTP connection name    */
} PATH_SWITCH;
```

## Supplied parameters

The application supplies the following parameters:

### ***opcode***

AP\_PATH\_SWITCH

### ***rtp\_connection\_name***

The RTP connection for which a change in path is requested. This is an 8-byte string in a locally displayable character set. All eight bytes are significant and must be set.

## Returned parameters: successful execution

If the verb executes successfully, CS/AIX returns the following parameters:

### ***primary\_rc***

AP\_OK

## Returned parameters: parameter check

If the verb does not execute because of a parameter error, CS/AIX returns the following parameters:

### ***primary\_rc***

AP\_PARAMETER\_CHECK

### ***secondary\_rc***

#### **AP\_INVALID\_RTP\_CONNECTION**

The value specified for the *rtp\_connection\_name* parameter did not match the name of an existing RTP connection.

Appendix B, “Common return codes,” on page 661 lists further secondary return codes associated with AP\_PARAMETER\_CHECK, which are common to all NOF verbs.

## Returned parameters: state check

If the verb does not execute because of a state error, CS/AIX returns the following parameters.

### ***primary\_rc***

AP\_STATE\_CHECK

### ***secondary\_rc***

#### **AP\_PATH\_SWITCH\_IN\_PROGRESS**

CS/AIX is currently changing the path for the RTP connection specified by the *rtp\_connection\_name* parameter.

Appendix B, “Common return codes,” on page 661 lists further secondary return codes associated with AP\_STATE\_CHECK, which are common to all NOF verbs.

## Returned parameters: path switch disabled

If the verb does not execute because the RTP partner node has disabled path switch by setting the path switch timer to zero, CS/AIX returns the following parameter:

## QUERY\_ACTIVE\_TRANSACTION

### *primary\_rc*

AP\_PATH\_SWITCH\_DISABLED

### *secondary\_rc*

(No secondary return code is returned.)

## Returned parameters: path switch failure

If the verb does not execute because the path switch attempt fails, CS/AIX returns the following parameter:

### *primary\_rc*

AP\_UNSUCCESSFUL

### *secondary\_rc*

(No secondary return code is returned.)

## Returned parameters: node check

If the verb does not execute because the system has not been built with RTP support, CS/AIX returns the following parameter:

### *primary\_rc*

AP\_INVALID\_VERB

### *secondary\_rc*

(No secondary return code is returned.)

## Returned parameters: other conditions

Appendix B, “Common return codes,” on page 661 lists further combinations of primary and secondary return codes that are common to all NOF verbs.

## QUERY\_ACTIVE\_TRANSACTION

---

QUERY\_ACTIVE\_TRANSACTION returns information about active Multiple Domain Support (MDS) transactions known to the CS/AIX Management Services component. An active transaction is an MDS request for which a reply has not yet been received.

This verb may be used to obtain information about a single transaction, or on multiple transactions, depending on the options used.

This verb must be issued to a running node.

## VCB structure

```
typedef struct query_active_transaction
{
    AP_UINT16      opcode;                /* verb operation code          */
    unsigned char  reserv2;               /* reserved                     */
    unsigned char  format;               /* reserved                     */
    AP_UINT16      primary_rc;           /* primary return code         */
    AP_UINT32      secondary_rc;        /* secondary return code       */
    unsigned char  *buf_ptr;             /* pointer to buffer           */
    AP_UINT32      buf_size;             /* buffer size                 */
    AP_UINT32      total_buf_size;      /* total buffer size required  */
    AP_UINT16      num_entries;          /* number of entries           */
    AP_UINT16      total_num_entries;   /* total number of entries     */
    unsigned char  list_options;        /* listing options             */
    unsigned char  reserv3;             /* reserved                     */
    unsigned char  fq_req_loc_cp_name[17]; /* fq cp name of transaction  */
    unsigned char  req_agent_appl_name[8]; /* appl name of transaction   */
    unsigned char  seq_num_dt[17];      /* sequence number date/time   */
} QUERY_ACTIVE_TRANSACTION;
```

```

typedef struct active_transaction_data
{
    AP_UINT16      overlay_size;           /* size of returned entry */
    unsigned char  fq_origin_cp_name[17]; /* cp name of transaction origin */
    unsigned char  origin_ms_appl_name[8]; /* appl name of transaction */
                                           /* origin */
    unsigned char  fq_dest_cp_name[17];   /* cp name of transaction */
                                           /* destination */
    unsigned char  dest_ms_appl_name[8];  /* appl name of transaction dest */
    unsigned char  fq_req_loc_cp_name[17]; /* fq cp name of transaction */
                                           /* requestor */
    unsigned char  req_agent_appl_name[8]; /* appl name of transaction */
                                           /* requestor */
    unsigned char  seq_num_dt[17];        /* sequence number date/time */
    unsigned char  reserva[20];          /* reserved */
} ACTIVE_TRANSACTION_DATA;

```

## Supplied parameters

The application supplies the following parameters:

### **opcode**

AP\_QUERY\_ACTIVE\_TRANSACTION

### **buf\_ptr**

A pointer to a data buffer that CS/AIX will use to return the requested information.

### **buf\_size**

Size of the supplied data buffer.

### **num\_entries**

Maximum number of transactions for which data should be returned. To request data for a specific transaction rather than a range, specify the value 1. To return as many entries as possible, specify zero; in this case, CS/AIX will return the maximum number of entries that can be accommodated in the supplied data buffer.

### **list\_options**

The position in the list from which CS/AIX should begin to return data. Possible values are:

#### **AP\_FIRST\_IN\_LIST**

Start at the first entry in the list.

#### **AP\_LIST\_INCLUSIVE**

Start at the entry specified by the *fq\_req\_loc\_cp\_name*, *req\_agent\_appl\_name*, and *seq\_num\_dt* parameters.

#### **AP\_LIST\_FROM\_NEXT**

Start at the entry immediately following the entry specified by the *fq\_req\_loc\_cp\_name*, *req\_agent\_appl\_name*, and *seq\_num\_dt* parameters.

The list is ordered by *fq\_req\_loc\_cp\_name*, then by *req\_agent\_appl\_name*, and finally in numerical order of *seq\_num\_dt*. For more information about how the list is ordered and how the application can obtain specific entries from it, see [“List options for QUERY\\_\\* Verbs” on page 33](#).

### **fq\_req\_loc\_cp\_name**

Fully qualified control point name of the transaction requestor. This parameter is ignored if *list\_options* is set to AP\_FIRST\_IN\_LIST. The name is a 17-byte EBCDIC string, right-padded with EBCDIC spaces. It consists of a network ID of up to 8 A-string characters, an EBCDIC dot (period) character, and a network name of up to 8 A-string characters.

### **req\_agent\_appl\_name**

Application name of the transaction requestor. This parameter is ignored if *list\_options* is set to AP\_FIRST\_IN\_LIST.

This name is normally an EBCDIC string, using type-1134 characters (uppercase A-Z and numerals 0-9); alternatively, it can be one of the MS Discipline-Specific Application Programs specified in *SNA Management Services Reference*. The string must be 8 characters long; pad on the right with EBCDIC space characters (0x40) if necessary.

### ***seq\_num\_dt***

Sequence number date/time correlator (17 bytes long) of the original transaction, as defined in the IBM SNA Formats manual. This parameter is ignored if *list\_options* is set to AP\_FIRST\_IN\_LIST.

## Returned parameters: successful execution

If the verb executes successfully, CS/AIX returns the following parameters:

### ***primary\_rc***

AP\_OK

### ***buf\_size***

Length of the information returned in the supplied buffer.

### ***total\_buf\_size***

Returned value indicating the size of buffer that would have been required to return all the list information requested. A value greater than *buf\_size* indicates that not all the available entries were returned.

### ***num\_entries***

Number of entries returned in the data buffer.

### ***total\_num\_entries***

Total number of entries available. A value greater than *num\_entries* indicates that not all the available entries were returned.

Each entry in the data buffer consists of the following parameters:

### ***active\_transaction\_data.overlay\_size***

The size of the returned *active\_transaction\_data* structure, and therefore the offset to the start of the next entry in the data buffer.

When your application needs to go through the returned buffer to find each *active\_transaction\_data* structure in turn, it must use this value to move to the correct offset for the next data structure, and must not use the C `sizeof()` operator. This is because the size of the returned overlay may increase in future releases of CS/AIX; using the returned overlay size ensures that your application will continue to work with future releases.

### ***active\_transaction\_data.fq\_origin\_cp\_name***

Fully qualified control point name of the origin for the transaction. The name is a 17-byte EBCDIC string, right-padded with EBCDIC spaces. It consists of a network ID of up to 8 A-string characters, an EBCDIC dot (period) character, and a network name of up to 8 A-string characters.

### ***active\_transaction\_data.origin\_ms\_appl\_name***

Application name of the origin for the transaction. This name is normally an 8-character EBCDIC string, using type-1134 characters (uppercase A-Z and numerals 0-9); alternatively, it can be one of the MS Discipline-Specific Application Programs specified in *Systems Network Architecture: Management Services Reference* (see the Bibliography).

### ***active\_transaction\_data.fq\_dest\_cp\_name***

Fully qualified control point name of the destination for the transaction. The name is a 17-byte EBCDIC string, right-padded with EBCDIC spaces. It consists of a network ID of up to 8 A-string characters, an EBCDIC dot (period) character, and a network name of up to 8 A-string characters.

### ***active\_transaction\_data.dest\_ms\_appl\_name***

Application name of the destination application for the transaction. This name is normally an 8-character EBCDIC string, using type-1134 characters (uppercase A-Z and numerals 0-9); alternatively, it can be one of the MS Discipline-Specific Application Programs specified in *Systems Network Architecture: Management Services Reference* (see the Bibliography).

### ***active\_transaction\_data.fq\_req\_loc\_cp\_name***

Fully qualified control point name of the transaction requestor. The name is a 17-byte EBCDIC string, right-padded with EBCDIC spaces. It consists of a network ID of up to 8 A-string characters, an EBCDIC dot (period) character, and a network name of up to 8 A-string characters.

***active\_transaction\_data.req\_agent\_appl\_name***

Application name of the transaction requestor. This name is normally an 8-character EBCDIC string, using type-1134 characters (uppercase A-Z and numerals 0-9); alternatively, it can be one of the MS Discipline-Specific Application Programs specified in *Systems Network Architecture: Management Services Reference* (see the Bibliography).

***active\_transaction\_data.seq\_num\_dt***

Sequence number date/time correlator (17 bytes long) of the original transaction, as defined in the IBM SNA Formats manual.

**Returned parameters: parameter check**

If the verb does not execute because of a parameter error, CS/AIX returns the following parameters:

***primary\_rc***

AP\_PARAMETER\_CHECK

***secondary\_rc***

Possible values are:

**AP\_INVALID\_ACTIVE\_TRANSACTION**

The control point name, application name, or sequence number correlator did not match that of an active transaction.

**AP\_INVALID\_LIST\_OPTION**

The *list\_options* parameter was not set to a valid value.

Appendix B, “Common return codes,” on page 661 lists further secondary return codes associated with AP\_PARAMETER\_CHECK, which are common to all NOF verbs.

**Returned parameters: function not supported**

If the verb does not execute successfully because the local node configuration does not support it, CS/AIX returns the following parameters:

***primary\_rc*****AP\_FUNCTION\_NOT\_SUPPORTED**

The local node does not support MS network management functions; this is defined by the *mds\_supported* parameter on the DEFINE\_NODE verb.

**Returned parameters: other conditions**

Appendix B, “Common return codes,” on page 661 lists further combinations of primary and secondary return codes that are common to all NOF verbs.

**QUERY\_ADJACENT\_NN**

The QUERY\_ADJACENT\_NN verb returns information about adjacent network nodes (the network nodes to which CP-CP sessions are active or have been active at some time). It can be used only if the CS/AIX node is a network node, and is not valid if it is an end node or LEN node.

This verb can be used to obtain information about a specific adjacent network node, or about multiple adjacent network nodes, depending on the options used.

This verb must be issued to a running node.

**VCB structure**

```
typedef struct query_adjacent_nn
{
    AP_UINT16    opcode;                /* verb operation code      */
    unsigned char reserv2;             /* reserved                  */
    unsigned char format;              /* reserved                  */
    AP_UINT16    primary_rc;           /* primary return code      */
}
```

## QUERY\_ADJACENT\_NN

```
    AP_UINT32      secondary_rc;          /* secondary return code          */
    unsigned char  *buf_ptr;              /* pointer to buffer              */
    AP_UINT32      buf_size;              /* buffer size                    */
    AP_UINT32      total_buf_size;        /* total buffer size required     */
    AP_UINT16      num_entries;           /* number of entries              */
    AP_UINT16      total_num_entries;     /* total number of entries        */
    unsigned char  list_options;          /* listing options                */
    unsigned char  reserv3;               /* reserved                       */
    unsigned char  adj_nncp_name[17];     /* CP name of adjacent Network Node */
} QUERY_ADJACENT_NN;
```

```
typedef struct adj_nncp_data
{
    AP_UINT16      overlay_size;          /* size of returned entry         */
    unsigned char  adj_nncp_name[17];     /* CP name of adjacent network node */
    unsigned char  cp_cp_sess_status;     /* CP-CP session status          */
    AP_UINT32      out_of_seq_tdus;       /* out of sequence TDUs          */
    AP_UINT32      last_frsn_sent;        /* last FRSN sent                 */
    AP_UINT32      last_frsn_rcvd;       /* last FRSN received            */
    unsigned char  reserva[20];           /* reserved                       */
} ADJ_NNCP_DATA;
```

## Supplied parameters

The application supplies the following parameters:

### ***opcode***

AP\_QUERY\_ADJACENT\_NN

### ***buf\_ptr***

A pointer to a data buffer that CS/AIX will use to return the requested information.

### ***buf\_size***

Size of the supplied data buffer.

### ***num\_entries***

Maximum number of adjacent NNs for which data should be returned. To request data for a specific adjacent NN rather than a range, specify the value 1. To return as many entries as possible, specify zero; in this case, CS/AIX will return the maximum number of entries that can be accommodated in the supplied data buffer.

### ***list\_options***

The position in the list of adjacent NNs from which CS/AIX should begin to return data. Possible values are:

#### **AP\_FIRST\_IN\_LIST**

Start at the first entry in the list.

#### **AP\_LIST\_INCLUSIVE**

Start at the entry specified by the *adj\_nncp\_name* parameter.

#### **AP\_LIST\_FROM\_NEXT**

Start at the entry immediately following the entry specified by the *adj\_nncp\_name* parameter.

For more information about how the list is ordered and how the application can obtain specific entries from it, see [“List options for QUERY\\_\\* Verbs”](#) on page 33.

### ***adj\_nncp\_name***

Fully qualified name of the adjacent NN for which information is required, or the name to be used as an index into the list of adjacent NNs. This value is ignored if *list\_options* is set to AP\_FIRST\_IN\_LIST.

The name is a 17-byte EBCDIC string, right-padded with EBCDIC spaces. It consists of a network ID of up to 8 A-string characters, an EBCDIC dot (period) character, and a network name of up to 8 A-string characters.

## Returned parameters: successful execution

If the verb executes successfully, CS/AIX returns the following parameters:



**primary\_rc**

AP\_OK

**buf\_size**

Length of the information returned in the supplied buffer.

**total\_buf\_size**

Returned value indicating the size of buffer that would have been required to return all the list information requested. A value greater than *buf\_size* indicates that not all the available entries were returned.

**num\_entries**

Number of entries returned in the data buffer.

**total\_num\_entries**

Total number of entries available. A value greater than *num\_entries* indicates that not all the available entries were returned.

Each entry in the data buffer consists of the following parameters:

**adj\_nncp\_data.overlay\_size**

The size of the returned *adj\_nncp\_data* structure, and therefore the offset to the start of the next entry in the data buffer.

When your application needs to go through the returned buffer to find each *adj\_nncp\_data* structure in turn, it must use this value to move to the correct offset for the next data structure, and must not use the C `sizeof()` operator. This is because the size of the returned overlay may increase in future releases of CS/AIX; using the returned overlay size ensures that your application will continue to work with future releases.

**adj\_nncp\_data.adj\_nncp\_name**

Fully qualified name of the adjacent NN. The name is a 17-byte EBCDIC string, padded on the right with EBCDIC spaces. It consists of a network ID of 1-8 A-string characters, an EBCDIC dot (period) character, and a network name of 1-8 A-string characters.

**adj\_nncp\_data.cp\_cp\_sess\_status**

Status of the CP-CP session to the adjacent NN. Possible values are:

**AP\_ACTIVE**

The session is active.

**AP\_CONWINNER\_ACTIVE**

The session (a contention-winner session) is active.

**AP\_CONLOSER\_ACTIVE**

The session (a contention-loser session) is active.

**AP\_INACTIVE**

The session is inactive.

**adj\_nncp\_data.out\_of\_seq\_t dus**

Number of out-of-sequence TDUs received from this node.

**adj\_nncp\_data.last\_frsn\_sent**

The last Flow Reduction Sequence Number (FRSN) sent to this node.

**adj\_nncp\_data.last\_frsn\_rcvd**

The last Flow Reduction Sequence Number (FRSN) received from this node.

## Returned parameters: parameter check

If the verb does not execute because of a parameter error, CS/AIX returns the following parameters:

**primary\_rc**

AP\_PARAMETER\_CHECK

**secondary\_rc**

Possible values are:

## QUERY\_AVAILABLE\_TP

### AP\_INVALID\_ADJ\_NNCP\_NAME

The *list\_options* parameter was set to AP\_LIST\_INCLUSIVE, to list all entries starting from the supplied name, but the *adj\_nncp\_name* parameter was not valid.

### AP\_INVALID\_LIST\_OPTION

The *list\_options* parameter was not set to a valid value.

Appendix B, “Common return codes,” on page 661 lists further secondary return codes associated with AP\_PARAMETER\_CHECK, which are common to all NOF verbs.

## Returned parameters: function not supported

If the verb does not execute successfully because the local node is not a network node, CS/AIX returns the following parameters:

### *primary\_rc*

#### AP\_FUNCTION\_NOT\_SUPPORTED

The local node is an end node or LEN node. This verb is valid only at a network node.

## Returned parameters: other conditions

Appendix B, “Common return codes,” on page 661 lists further combinations of primary and secondary return codes that are common to all NOF verbs.

## QUERY\_AVAILABLE\_TP

---

QUERY\_AVAILABLE\_TP returns information about active invocable TPs (APPC applications that have issued the RECEIVE\_ALLOCATE verb, or CPI-C applications that have issued the Accept\_Conversation or Accept\_Incoming call). This verb can be used to obtain information about a specific TP or about multiple TPs, depending on the options used. This verb returns information about all such TPs that are running, whether or not they currently have an APPC verb or CPI-C call outstanding to accept a new incoming conversation.

This verb must be issued to a running node.

## VCB structure

```
typedef struct query_available_tp
{
    AP_UINT16      opcode;           /* Verb operation code          */
    unsigned char  reserv2;         /* reserved                     */
    unsigned char  format;         /* reserved                     */
    AP_UINT16      primary_rc;     /* Primary return code          */
    AP_UINT32      secondary_rc;   /* Secondary return code        */
    unsigned char  *buf_ptr;       /* pointer to buffer            */
    AP_UINT32      buf_size;       /* buffer size                  */
    AP_UINT32      total_buf_size; /* total buffer size required   */
    AP_UINT16      num_entries;    /* number of entries            */
    AP_UINT16      total_num_entries; /* total number of entries     */
    unsigned char  list_options;   /* listing options              */
    unsigned char  reserv3[3];     /* reserved                     */
    unsigned char  tp_name[64];    /* TP name                      */
    unsigned char  system_name[128]; /* computer name where TP is   */
    /* running */
} QUERY_AVAILABLE_TP;
```

```
typedef struct available_tp_data
{
    AP_UINT16      overlay_size;    /* size of returned entry      */
    unsigned char  tp_name[64];    /* TP name                     */
    unsigned char  reserv4[4];     /* reserved                    */
    unsigned char  system_name[128]; /* computer name where TP is   */
    /* running */
} AVAILABLE_TP_DATA;
```

## Supplied parameters

The application supplies the following parameters:

***opcode***

AP\_QUERY\_AVAILABLE\_TP

***buf\_ptr***

A pointer to a data buffer that CS/AIX will use to return the requested information.

***buf\_size***

Size of the supplied data buffer.

***num\_entries***

Maximum number of TPs for which data should be returned. To request data for a specific TP rather than a range, specify the value 1. To return as many entries as possible, specify zero; in this case, CS/AIX will return the maximum number of entries that can be accommodated in the supplied data buffer.

***list\_options***

The position in the list of TPs from which CS/AIX should begin to return data. Possible values are:

**AP\_FIRST\_IN\_LIST**

Start at the first entry in the list.

**AP\_LIST\_INCLUSIVE**

Start at the entry specified by the combination of TP name and system name.

**AP\_LIST\_FROM\_NEXT**

Start at the entry immediately following the entry specified by the combination of TP name and system name.

For more information about how the list is ordered and how the application can obtain specific entries from it, see [“List options for QUERY\\_\\* Verbs” on page 33](#).

***tp\_name***

TP name. This is a 64-byte string, padded on the right with spaces if the name is shorter than 64 characters. This value is ignored if *list\_options* is set to AP\_FIRST\_IN\_LIST.

***system\_name***

The computer name for which TP information is required. The system name is an ASCII string of 1-128 characters, which must match a CS/AIX computer name. This value is ignored if *list\_options* is set to AP\_FIRST\_IN\_LIST.

If the computer name includes a . (period) character, CS/AIX assumes that it is a fully-qualified name; otherwise it performs a DNS lookup to determine the computer name.

If CS/AIX is running with all programs on a single computer, there is no need to specify the computer name (it can be left as all binary zeros). For a client/server system, specify the computer name to list only TPs on the specified computer, or leave it as all binary zeros to list TPs on all computers.

## Returned parameters: successful execution

If the verb executes successfully, CS/AIX returns the following parameters:

***primary\_rc***

AP\_OK

***buf\_size***

Length of the information returned in the supplied buffer.

***total\_buf\_size***

Returned value indicating the size of buffer that would have been required to return all the list information requested. A value greater than *buf\_size* indicates that not all the available entries were returned.

***num\_entries***

Number of entries returned in the data buffer.

## QUERY\_BUFFER\_AVAILABILITY

### ***total\_num\_entries***

Total number of entries available. A value greater than *num\_entries* indicates that not all the available entries were returned.

Each entry in the data buffer consists of the following parameters:

### ***available\_tp\_data.overlay\_size***

The size of the returned *available\_tp\_data* structure, and therefore the offset to the start of the next entry in the data buffer.

When your application needs to go through the returned buffer to find each *available\_tp\_data* structure in turn, it must use this value to move to the correct offset for the next data structure, and must not use the C `sizeof()` operator. This is because the size of the returned overlay may increase in future releases of CS/AIX; using the returned overlay size ensures that your application will continue to work with future releases.

### ***available\_tp\_data.tp\_name***

TP name. This is a 64-byte string, padded on the right with spaces if the name is shorter than 64 characters.

### ***available\_tp\_data.system\_name***

Name of the computer where the TP is running.

## Returned parameters: parameter check

If the verb does not execute because of a parameter error, CS/AIX returns the following parameters:

### ***primary\_rc***

AP\_PARAMETER\_CHECK

### ***secondary\_rc***

Possible values are:

#### **AP\_INVALID\_LIST\_OPTION**

The *list\_options* parameter was not set to a valid value.

#### **AP\_UNKNOWN\_TP**

The *list\_options* parameter was set to AP\_LIST\_INCLUSIVE, to list all entries starting from the supplied name, but the *tp\_name* parameter was not valid.

Appendix B, “Common return codes,” on page 661 lists further secondary return codes associated with AP\_PARAMETER\_CHECK, which are common to all NOF verbs.

## Returned parameters: other conditions

Appendix B, “Common return codes,” on page 661 lists further combinations of primary and secondary return codes that are common to all NOF verbs.

## QUERY\_BUFFER\_AVAILABILITY

---

This verb returns information about the amount of STREAMS buffers that CS/AIX is currently using, the maximum amount it has used, and the maximum amount available (specified using the SET\_BUFFER\_AVAILABILITY verb). This allows you to check STREAMS buffer usage and set the limit appropriately, to ensure that sufficient buffers are available for CS/AIX components and for other programs on the AIX computer. The verb also returns additional internal values relating to buffer usage, for use by CS/AIX support personnel.

## VCB structure

```
typedef struct query_buffer_availability
{
    AP_UINT16      opcode;           /* verb operation code      */
    unsigned char  reserv2;         /* reserved                 */
    unsigned char  format;          /* reserved                 */
    AP_UINT16      primary_rc;      /* primary return code     */
}
```

```

AP_UINT32      secondary_rc;          /* secondary return code      */
AP_UINT32      reset_max_values;     /* set stored max values to  */
AP_UINT32      buf_avail;           /* current                    */
AP_UINT32      buf_total_count;     /* maximum buffer space      */
AP_UINT32      buf_total_bytes;     /* available                  */
AP_UINT32      buf_rsrv_count;      /* current buffer usage - count */
AP_UINT32      buf_rsrv_bytes[2];   /* current buffer usage - bytes */
AP_UINT32      buf_res_use_count;   /* buffers reserved - count  */
AP_UINT32      buf_res_use_bytes;   /* buffers reserved - bytes  */
AP_UINT32      buf_res_use_count;   /* usage of reserved buffers */
AP_UINT32      buf_res_use_bytes;   /* - count                   */
AP_UINT32      buf_res_use_bytes;   /* usage of reserved buffers */
AP_UINT32      buf_res_use_bytes;   /* - bytes                   */
AP_UINT32      peak_usage;          /* peak usage                 */
AP_UINT32      peak_decay;          /* peak decay                 */
unsigned char  throttle_status;     /* throttle status           */
unsigned char  buf_use_status;      /* congestion status         */
AP_UINT32      max_buf_total_count; /* maximum buffer usage - count */
AP_UINT32      max_buf_total_bytes; /* maximum buffer usage - bytes */
AP_UINT32      max_buf_rsrv_count;  /* max buffers reserved - count */
AP_UINT32      max_buf_rsrv_bytes[2]; /* max buffers reserved - bytes */
AP_UINT32      max_buf_res_use_count; /* max rsrv buffer usage - count */
AP_UINT32      max_buf_res_use_bytes; /* max rsrv buffer usage - bytes */
AP_UINT32      max_peak_usage;     /* maximum peak usage        */
unsigned char  max_throttle_status; /* maximum throttle status   */
unsigned char  max_buf_use_status;  /* maximum congestion status  */
unsigned char  debug_param[32];     /* reserved                  */
unsigned char  reserv3[8];          /* reserved                   */
} QUERY_BUFFER_AVAILABILITY;

```

## Supplied parameters

The application supplies the following parameters:

### **opcode**

AP\_QUERY\_BUFFER\_AVAILABILITY

### **reset\_max\_values**

Specify whether CS/AIX should reset the values for the *max\_\** parameters (after returning them on this verb) to match the current values of these parameters. This ensures that a subsequent QUERY\_BUFFER\_AVAILABILITY verb will return the maximum values reached since this verb, rather than the maximum values reached since the system was started (or since the values for the *max\_\** parameters were last reset). Possible values are:

#### **AP\_YES**

Reset the values for the *max\_\** parameters to match the current values.

#### **AP\_NO**

Do not reset the values for the *max\_\** parameters.

## Returned parameters: successful execution

If the verb executes successfully, CS/AIX returns the following parameters. Values returned in other fields are for use by CS/AIX support personnel.

### **primary\_rc**

AP\_OK

### **secondary\_rc**

Not used.

### **buf\_avail**

The maximum amount of STREAMS buffer space available to CS/AIX, in bytes, as defined by a SET\_BUFFER\_AVAILABILITY verb.

### **buf\_total\_count**

The number of buffers currently allocated to CS/AIX components.

### **buf\_total\_bytes**

The total amount of storage in buffers currently allocated to CS/AIX components.

## QUERY\_CENTRAL\_LOGGER

### ***buf\_rsrv\_count***

The total number of buffers reserved.

### ***buf\_rsrv\_bytes***

The total amount of storage in buffers reserved, in bytes.

### ***buf\_res\_use\_count***

The number of reserved buffers in use.

### ***buf\_res\_use\_bytes***

The number of bytes in the reserved buffers currently in use.

### ***peak\_usage***

Peak buffer usage - smoothed percentage of buffers that are actually used.

### ***peak\_decay***

Smoothing parameter.

### ***throttle\_status***

Adaptive pacing status.

### ***buf\_use\_status***

Congestion status. Possible values are:

- AP\_CONGESTED
- AP\_UNCONGESTED

### ***max\_buf\_total\_count***

The maximum number of buffers that have been allocated to CS/AIX components at any time.

### ***max\_buf\_total\_bytes***

The maximum amount of buffer storage that has been allocated to CS/AIX components at any time.

### ***max\_buf\_rsrv\_count***

The maximum number of buffers that can be reserved.

### ***max\_buf\_rsrv\_bytes***

The maximum amount of buffer storage that can be reserved, in bytes.

### ***max\_buf\_res\_use\_count***

The maximum number of reserved buffers that can be in use.

### ***max\_buf\_res\_use\_bytes***

The maximum number of bytes of reserved buffers that can be in use at any time.

### ***max\_peak\_usage***

Maximum peak buffer usage - smoothed percentage of buffers actually used.

### ***max\_throttle\_status***

Maximum adaptive pacing status.

### ***max\_buf\_use\_status***

Maximum congestion status. Possible values are:

- AP\_CONGESTED
- AP\_UNCONGESTED

## Returned parameters: other conditions

Appendix B, “Common return codes,” on [page 661](#) lists further combinations of primary and secondary return codes that are common to all NOF verbs.

## QUERY\_CENTRAL\_LOGGER

---

This verb returns the name of the node currently defined as the central logger (the node holding the central log file to which CS/AIX log messages from all servers are sent). This verb does not return information about whether central logging is active; use `QUERY_CENTRAL_LOGGING` to determine this.

This verb must be issued with a null target handle.

## VCB structure

```
typedef struct query_central_logger
{
    AP_UINT16      opcode;           /* verb operation code      */
    unsigned char  reserv2;         /* reserved                 */
    unsigned char  format;         /* reserved                 */
    AP_UINT16      primary_rc;      /* primary return code     */
    AP_UINT32      secondary_rc;    /* secondary return code   */
    unsigned char  reserv3[4];     /* reserved                 */
    unsigned char  node_name[128]; /* name of central logger  */
} QUERY_CENTRAL_LOGGER;
```

## Supplied parameters

The application supplies the following parameter:

### *opcode*

AP\_QUERY\_CENTRAL\_LOGGER

## Returned parameters: successful execution

If the verb executes successfully, CS/AIX returns the following parameters:

### *primary\_rc*

AP\_OK

### *secondary\_rc*

Not used.

### *node\_name*

The name of the node defined as the central logger.

## Returned parameters: state check

If the verb does not execute because of a state error, CS/AIX returns the following parameters:

### *primary\_rc*

AP\_STATE\_CHECK

### *secondary\_rc*

**AP\_NO\_CENTRAL\_LOG**

No controller server is currently active.

## Returned parameters: other conditions

Appendix B, “Common return codes,” on page 661 lists further combinations of primary and secondary return codes that are common to all NOF verbs.

## QUERY\_CENTRAL\_LOGGING

This verb returns information about whether CS/AIX log messages are sent to a central file from all servers, or to a separate file on each server. For more information, see “[SET\\_LOG\\_FILE](#)” on page 568.

This verb must be issued to the node that is currently acting as the central logger; for information about accessing this node, see “[CONNECT\\_NODE](#)” on page 51.

## VCB structure

```
typedef struct query_central_logging
{
    AP_UINT16      opcode;           /* verb operation code      */
    unsigned char  reserv2;         /* reserved                 */
    unsigned char  format;         /* reserved                 */
    AP_UINT16      primary_rc;      /* primary return code     */
}
```

## QUERY\_CENTRAL\_LOGGING

```
    AP_UINT32      secondary_rc;    /* secondary return code    */
    unsigned char  enabled;        /* is central logging enabled? */
    unsigned char  reserv3[3];     /* reserved                  */
} QUERY_CENTRAL_LOGGING;
```

### Supplied parameters

The application supplies the following parameter:

#### *opcode*

AP\_QUERY\_CENTRAL\_LOGGING

### Returned parameters: successful execution

If the verb executes successfully, CS/AIX returns the following parameters:

#### *primary\_rc*

AP\_OK

#### *secondary\_rc*

Not used.

#### *enabled*

Specifies whether central logging is enabled or disabled. Possible values are:

##### **AP\_YES**

Central logging is enabled. All log messages are sent to a single file on the node currently acting as the central logger.

##### **AP\_NO**

Central logging is disabled. Log messages from each server are sent to a file on that server (specified using the SET\_LOG\_FILE verb).

### Returned parameters: parameter check

If the verb does not execute because of a parameter error, CS/AIX returns the following parameters:

#### *primary\_rc*

AP\_PARAMETER\_CHECK

#### *secondary\_rc*

##### **AP\_NOT\_CENTRAL\_LOGGER**

The verb was issued to a node that is not the central logger.

### State check

If the command does not execute because of a state error, CS/AIX returns the following parameters:

#### *primary\_rc*

AP\_STATE\_CHECK

#### *secondary\_rc*

##### **AP\_NO\_CENTRAL\_LOG**

No controller server is currently active.

### Returned parameters: other conditions

Appendix B, “Common return codes,” on page 661 lists further combinations of primary and secondary return codes that are common to all NOF verbs.



## QUERY\_CN

QUERY\_CN returns information about adjacent Connection Networks. This information is structured as "determined data" (data gathered dynamically during execution) and "defined data" (the data supplied by the application on DEFINE\_CN).

This verb can be used to obtain information about a specific connection network, or about multiple connection networks, depending on the options used. It can be issued only at a network node or an end node; it is not valid at a LEN node.

### VCB structure

```
typedef struct query_cn
{
    AP_UINT16      opcode;           /* Verb operation code          */
    unsigned char  reserv2;         /* reserved                     */
    unsigned char  format;         /* reserved                     */
    AP_UINT16      primary_rc;     /* Primary return code         */
    AP_UINT32      secondary_rc;   /* Secondary return code       */
    unsigned char  *buf_ptr;       /* pointer to buffer           */
    AP_UINT32      buf_size;       /* buffer size                 */
    AP_UINT32      total_buf_size; /* total buffer size required  */
    AP_UINT16      num_entries;    /* number of entries           */
    AP_UINT16      total_num_entries; /* total number of entries    */
    unsigned char  list_options;   /* listing options             */
    unsigned char  reserv3;       /* reserved                     */
    unsigned char  fqcname[17];    /* Name of Connection Network  */
} QUERY_CN;
```

```
typedef struct cn_data
{
    AP_UINT16      overlay_size;   /* size of returned entry      */
    unsigned char  fqcname[17];   /* Name of Connection Network  */
    unsigned char  reserv1;       /* reserved                     */
    CN_DET_DATA    det_data;      /* Determined data             */
    CN_DEF_DATA    def_data;      /* Defined data                */
} CN_DATA;
```

```
typedef struct cn_det_data
{
    AP_UINT16      num_act_ports;  /* number of active ports     */
    unsigned char  reserv2[20];   /* reserved                    */
} CN_DET_DATA;
```

```
typedef struct cn_def_data
{
    unsigned char  description[32]; /* resource description        */
    unsigned char  reserve0[16];   /* reserved                    */
    unsigned char  num_ports;      /* number of ports on CN     */
    unsigned char  cn_type;        /* reserved                    */
    unsigned char  ipv6_addr_only; /* use IPv6 address          */
    unsigned char  reserve1[14];   /* reserved                    */
    TG_DEFINED_CHARS tg_chars;     /* TG characteristics        */
} CN_DEF_DATA;
```

```
typedef struct tg_defined_chars
{
    unsigned char  effect_cap;     /* effective capacity         */
    unsigned char  reserve1[5];    /* reserved                   */
    unsigned char  connect_cost;  /* connection cost           */
    unsigned char  byte_cost;     /* byte cost                 */
    unsigned char  reserve2;      /* reserved                   */
    unsigned char  security;      /* security                  */
    unsigned char  prop_delay;    /* propagation delay        */
    unsigned char  modem_class;   /* reserved                   */
    unsigned char  user_def_parm_1; /* user-defined parameter 1  */
    unsigned char  user_def_parm_2; /* user-defined parameter 2  */
    unsigned char  user_def_parm_3; /* user-defined parameter 3  */
} TG_DEFINED_CHARS;
```

## Supplied parameters

The application supplies the following parameters:

***opcode***

AP\_QUERY\_CN

***buf\_ptr***

A pointer to a data buffer that CS/AIX will use to return the requested information.

***buf\_size***

Size of the supplied data buffer.

***num\_entries***

Maximum number of CNs for which data should be returned. To request data for a specific CN rather than a range, specify the value 1. To return as many entries as possible, specify zero; in this case, CS/AIX will return the maximum number of entries that can be accommodated in the supplied data buffer.

***list\_options***

The position in the list of CNs from which CS/AIX should begin to return data. Possible values are:

**AP\_FIRST\_IN\_LIST**

Start at the first entry in the list.

**AP\_LIST\_INCLUSIVE**

Start at the entry specified by the *fqcn\_name* parameter.

**AP\_LIST\_FROM\_NEXT**

Start at the entry immediately following the entry specified by the *fqcn\_name* parameter.

For more information about how the list is ordered and how the application can obtain specific entries from it, see [“List options for QUERY\\_\\* Verbs” on page 33](#).

***fqcn\_name***

Fully qualified name of the CN for which information is required, or the name to be used as an index into the list of CNs. This value is ignored if *list\_options* is set to AP\_FIRST\_IN\_LIST.

The name is a 17-byte EBCDIC string, right-padded with EBCDIC spaces. It consists of a network ID of up to 8 A-string characters, an EBCDIC dot (period) character, and a network name of up to 8 A-string characters.

## Returned parameters: successful execution

If the verb executes successfully, CS/AIX returns the following parameters:

***primary\_rc***

AP\_OK

***buf\_size***

Length of the information returned in the supplied buffer.

***total\_buf\_size***

Returned value indicating the size of buffer that would have been required to return all the list information requested. A value greater than *buf\_size* indicates that not all the available entries were returned.

***num\_entries***

Number of entries returned in the data buffer.

***total\_num\_entries***

Total number of entries available. A value greater than *num\_entries* indicates that not all the available entries were returned.

Each entry in the data buffer consists of the following parameters:

***cn\_data.overlay\_size***

The size of the returned `cn_data` structure, and therefore the offset to the start of the next entry in the data buffer.

When your application needs to go through the returned buffer to find each `cn_data` structure in turn, it must use this value to move to the correct offset for the next data structure, and must not use the C `sizeof()` operator. This is because the size of the returned overlay may increase in future releases of CS/AIX; using the returned overlay size ensures that your application will continue to work with future releases.

***cn\_data.fqcn\_name***

Fully qualified name of the CN. The name is a 17-byte EBCDIC string, padded on the right with EBCDIC spaces. It consists of a network ID of 1-8 A-string characters, an EBCDIC dot (period) character, and a network name of 1-8 A-string characters.

***cn\_data.def\_data.num\_act\_ports***

The number of active ports on the connection network.

***cn\_data.def\_data.description***

A null-terminated text string describing the CN, as specified in the definition of the CN.

***cn\_data.def\_data.num\_ports***

The total number of ports on the connection network.

***cn\_data.def\_data.ipv6\_addr\_only***

For a Connection Network on an IPv6 network for HPR/IP, this parameter indicates if the IP addressing for the Connection Network uses IPv6 DNS names only or IPv6 addresses only. Possible values are:

**YES**

IP addressing for the Connection Network uses IPv6 addresses only.

**NO**

IP addressing for the Connection Network uses IPv6 DNS names only.

***cn\_data.def\_data.tg\_chars.effect\_cap***

Actual bits per second rate (line speed). The value is encoded as a 1-byte floating point number, represented by the formula  $0.1 \text{ mmm} * 2^{\text{eeeeee}}$  where the bit representation of the byte is `eeeeemmm`. Each unit of effective capacity is equal to 300 bits per second.

***cn\_data.def\_data.tg\_chars.connect\_cost***

Cost per connect time. Valid values are integer values in the range 0-255, where 0 is the lowest cost per connect time and 255 is the highest.

***cn\_data.def\_data.tg\_chars.byte\_cost***

Cost per byte. Values are integers in the range 0-255, where zero is the lowest cost per byte and 255 is the highest.

***cn\_data.def\_data.tg\_chars.security***

Security level of the network. Possible values are:

**AP\_SEC\_NONSECURE**

No security.

**AP\_SEC\_PUBLIC\_SWITCHED\_NETWORK**

Data is transmitted over a public switched network.

**AP\_SEC\_UNDERGROUND\_CABLE**

Data is transmitted over secure underground cable.

**AP\_SEC\_SECURE\_CONDUIT**

Data is transmitted over a line in a secure conduit that is not guarded.

**AP\_SEC\_GUARDED\_CONDUIT**

Data is transmitted over a line in a conduit that is protected against physical tapping.

**AP\_SEC\_ENCRYPTED**

Data is encrypted before transmission over the line.

## QUERY\_CN

### **AP\_SEC\_GUARDED\_RADIATION**

Data is transmitted over a line that is protected against physical and radiation tapping.

### **AP\_SEC\_MAXIMUM**

Maximum security.

### ***cn\_data.def\_data.tg\_chars.prop\_delay***

Propagation delay: the time that a signal takes to travel the length of the link. Possible values are:

### **AP\_PROP\_DELAY\_MINIMUM**

Minimum propagation delay.

### **AP\_PROP\_DELAY\_LAN**

Delay is less than 480 microseconds (typical for a LAN).

### **AP\_PROP\_DELAY\_TELEPHONE**

Delay is in the range 480-49,512 microseconds (typical for a telephone network).

### **AP\_PROP\_DELAY\_PKT\_SWITCHED\_NET**

Delay is in the range 49,512-245,760 microseconds (typical for a packet-switched network).

### **AP\_PROP\_DELAY\_SATELLITE**

Delay is greater than 245,760 microseconds (typical for a satellite link).

### **AP\_PROP\_DELAY\_MAXIMUM**

Maximum propagation delay.

### ***cn\_data.def\_data.tg\_chars.user\_def\_parm\_1* through *def\_data.tg\_chars.user\_def\_parm\_3***

User-defined parameters, which include other TG characteristics not covered by the above parameters. Each of these parameters is set to a value in the range 0-255.

## Returned parameters: parameter check

If the verb does not execute because of a parameter error, CS/AIX returns the following parameters:

### ***primary\_rc***

AP\_PARAMETER\_CHECK

### ***secondary\_rc***

Possible values are:

### **AP\_INVALID\_CN\_NAME**

The *list\_options* parameter was set to AP\_LIST\_INCLUSIVE, to list all entries starting from the supplied name, but the *fqcn\_name* parameter was not valid.

### **AP\_INVALID\_LIST\_OPTION**

The *list\_options* parameter was not set to a valid value.

Appendix B, "Common return codes," on page 661 lists further secondary return codes associated with AP\_PARAMETER\_CHECK, which are common to all NOF verbs.

## Returned parameters: function not supported

If the verb does not execute successfully because the local node is a LEN node, CS/AIX returns the following parameters:

### ***primary\_rc***

### **AP\_FUNCTION\_NOT\_SUPPORTED**

The local node is a LEN node. This verb is valid only at a network node or an end node.

## Returned parameters: other conditions

Appendix B, "Common return codes," on page 661 lists further combinations of primary and secondary return codes that are common to all NOF verbs.

## QUERY\_CN\_PORT

QUERY\_CN\_PORT returns information about ports defined on an adjacent Connection Network.

This verb can be used to obtain information about a specific port, or about multiple ports, depending on the options used. It can be issued only at a network node or an end node; it is not valid at a LEN node.

### VCB structure

```
typedef struct query_cn_port
{
    AP_UINT16          opcode;           /* Verb operation code          */
    unsigned char     reserv2;          /* reserved                     */
    unsigned char     format;           /* reserved                     */
    AP_UINT16         primary_rc;       /* Primary return code          */
    AP_UINT32         secondary_rc;     /* Secondary return code        */
    unsigned char     *buf_ptr;         /* pointer to buffer            */
    AP_UINT32         buf_size;         /* buffer size                  */
    AP_UINT32         total_buf_size;   /* total buffer size required   */
    AP_UINT16         num_entries;      /* number of entries            */
    AP_UINT16         total_num_entries; /* total number of entries      */
    unsigned char     list_options;     /* listing options              */
    unsigned char     reserv3;          /* reserved                     */
    unsigned char     fqcn_name[17];    /* Name of Connection Network   */
    unsigned char     port_name[8];     /* port name                    */
} QUERY_CN_PORT;
```

```
typedef struct cn_port_data
{
    AP_UINT16         overlay_size;     /* size of returned entry       */
    unsigned char     fqcn_name[17];    /* Name of Connection Network   */
    unsigned char     port_name[8];     /* name of port                 */
    unsigned char     tg_num;           /* transmission group number    */
    unsigned char     reserva[20];      /* reserved                      */
} CN_PORT_DATA;
```

### Supplied parameters

The application supplies the following parameters:

#### ***opcode***

AP\_QUERY\_CN\_PORT

#### ***buf\_ptr***

A pointer to a data buffer that CS/AIX will use to return the requested information.

#### ***buf\_size***

Size of the supplied data buffer.

#### ***num\_entries***

Maximum number of ports for which data should be returned. To request data for a specific port rather than a range, specify the value 1. To return as many entries as possible, specify zero; in this case, CS/AIX will return the maximum number of entries that can be accommodated in the supplied data buffer.

#### ***list\_options***

The position in the list of ports from which CS/AIX should begin to return data. Possible values are:

##### **AP\_FIRST\_IN\_LIST**

Start at the first entry in the list.

##### **AP\_LIST\_INCLUSIVE**

Start at the entry specified by the *port\_name* parameter.

##### **AP\_LIST\_FROM\_NEXT**

Start at the entry immediately following the entry specified by the *port\_name* parameter.

For more information about how the list is ordered and how the application can obtain specific entries from it, see [“List options for QUERY\\_\\* Verbs” on page 33](#).

***fqcn\_name***

Fully qualified name of the CN on which the required port is defined, or the CN for which a list of ports is required.

The name is a 17-byte EBCDIC string, right-padded with EBCDIC spaces. It consists of a network ID of up to 8 A-string characters, an EBCDIC dot (period) character, and a network name of up to 8 A-string characters.

***port\_name***

Name of the port for which information is required, or the name to be used as an index into the list of ports. This is an 8-byte ASCII string, padded on the right with spaces if the name is shorter than 8 characters.

**Returned parameters: successful execution**

If the verb executes successfully, CS/AIX returns the following parameters:

***primary\_rc***

AP\_OK

***buf\_size***

Length of the information returned in the supplied buffer.

***total\_buf\_size***

Returned value indicating the size of buffer that would have been required to return all the list information requested. A value greater than *buf\_size* indicates that not all the available entries were returned.

***num\_entries***

Number of entries returned in the data buffer.

***total\_num\_entries***

Total number of entries available. A value greater than *num\_entries* indicates that not all the available entries were returned.

Each entry in the data buffer consists of the following parameters:

***cn\_port\_data.overlay\_size***

The size of the returned *cn\_port\_data* structure, and therefore the offset to the start of the next entry in the data buffer.

When your application needs to go through the returned buffer to find each *cn\_port\_data* structure in turn, it must use this value to move to the correct offset for the next data structure, and must not use the C `sizeof()` operator. This is because the size of the returned overlay may increase in future releases of CS/AIX; using the returned overlay size ensures that your application will continue to work with future releases.

***cn\_port\_data.fqcn\_name***

Fully qualified name of the CN. The name is a 17-byte EBCDIC string, padded on the right with EBCDIC spaces. It consists of a network ID of 1-8 A-string characters, an EBCDIC dot (period) character, and a network name of 1-8 A-string characters.

***cn\_port\_data.port\_name***

Name of the port. This is an 8-byte ASCII string, padded on the right with spaces if the name is shorter than 8 characters.

***cn\_port\_data.tg\_num***

Transmission group number for the specified port.

**Returned parameters: parameter check**

If the verb does not execute because of a parameter error, CS/AIX returns the following parameters:

***primary\_rc***

AP\_PARAMETER\_CHECK

**secondary\_rc**

Possible values are:

**AP\_INVALID\_CN\_NAME**

The *list\_options* parameter was set to AP\_LIST\_INCLUSIVE, to list all entries starting from the supplied name, but the *fqcn\_name* parameter was not valid.

**AP\_INVALID\_PORT\_NAME**

The *list\_options* parameter was set to AP\_LIST\_INCLUSIVE, to list all entries starting from the supplied name, but the *port\_name* parameter was not valid.

**AP\_INVALID\_LIST\_OPTION**

The *list\_options* parameter was not set to a valid value.

Appendix B, “Common return codes,” on page 661 lists further secondary return codes associated with AP\_PARAMETER\_CHECK, which are common to all NOF verbs.

**Returned parameters: function not supported**

If the verb does not execute successfully because the local node is a LEN node, CS/AIX returns the following parameters:

**primary\_rc****AP\_FUNCTION\_NOT\_SUPPORTED**

The local node is a LEN node. This verb is valid only at a network node or an end node.

**Returned parameters: other conditions**

Appendix B, “Common return codes,” on page 661 lists further combinations of primary and secondary return codes that are common to all NOF verbs.

**QUERY\_CONVERSATION**

QUERY\_CONVERSATION returns information about conversations using a particular local LU.

This verb can be used to obtain information about a specific conversation or a range of conversations, depending on the options used.

This verb must be issued to a running node.

**VCB structure**

```
typedef struct query_conversation
{
    AP_UINT16      opcode;                /* verb operation code      */
    unsigned char  reserv2;               /* reserved                  */
    unsigned char  format;                /* reserved                  */
    AP_UINT16      primary_rc;            /* primary return code      */
    AP_UINT32      secondary_rc;         /* secondary return code    */
    unsigned char  *buf_ptr;              /* pointer to buffer        */
    AP_UINT32      buf_size;              /* buffer size              */
    AP_UINT32      total_buf_size;       /* total buffer size required */
    AP_UINT16      num_entries;           /* number of entries        */
    AP_UINT16      total_num_entries;     /* total number of entries  */
    unsigned char  list_options;         /* listing options          */
    unsigned char  reserv3;               /* reserved                  */
    unsigned char  lu_name[8];           /* LU Name                  */
    unsigned char  lu_alias[8];          /* LU Alias                  */
    AP_UINT32      conv_id;               /* Conversation ID          */
    unsigned char  session_id[8];        /* Session ID               */
    unsigned char  reserv4[12];          /* reserved                  */
} QUERY_CONVERSATION;
```

```
typedef struct conv_summary
{
    AP_UINT16      overlay_size;          /* overlay size             */
    AP_UINT32      conv_id;               /* conversation ID          */
    unsigned char  local_tp_name[64];     /* local TP name            */
}
```

## QUERY\_CONVERSATION

```
unsigned char partner_tp_name[64];          /* partner TP name          */
unsigned char tp_id[8];                    /* TP ID                     */
unsigned char sess_id[8];                  /* Session ID                */
AP_UINT32 conv_start_time;                 /* Conversation start time   */
AP_UINT32 bytes_sent;                      /* Number of bytes sent      */
AP_UINT32 bytes_received;                  /* Number of bytes received  */
unsigned char conv_state;                  /* conversation state        */
unsigned char duplex_type;                  /* full- or half-duplex conv? */
} CONV_SUMMARY;
```

## Supplied parameters

The application supplies the following parameters:

### **opcode**

AP\_QUERY\_CONVERSATION

### **buf\_ptr**

A pointer to a data buffer that CS/AIX will use to return the requested information.

### **buf\_size**

Size of the supplied data buffer.

### **num\_entries**

Maximum number of conversations for which data should be returned. To request data for a specific conversation rather than a range, specify the value 1. To return as many entries as possible, specify zero; in this case, CS/AIX will return the maximum number of entries that can be accommodated in the supplied data buffer.

### **list\_options**

The position in the list from which CS/AIX should begin to return data. Specify one of the following values:

#### **AP\_FIRST\_IN\_LIST**

Start at the first entry in the list.

#### **AP\_LIST\_INCLUSIVE**

Start at the entry specified by the combination of local LU and conversation ID.

#### **AP\_LIST\_FROM\_NEXT**

Start at the entry immediately following the entry specified by the combination of local LU and conversation ID.

The combination of the local LU (*lu\_name* or *lu\_alias*) and conversation ID (*conv\_id*) specified is used as an index into the list of sessions if the *list\_options* parameter is set to AP\_LIST\_INCLUSIVE or AP\_LIST\_FROM\_NEXT.

For more information about how the list is ordered and how the application can obtain specific entries from it, see [“List options for QUERY\\_\\* Verbs” on page 33](#).

### **lu\_name**

LU name. This is an 8-byte type-A EBCDIC string, padded on the right with spaces if the name is shorter than 8 characters. To specify that the LU is identified by its alias rather than its LU name, set this parameter to 8 binary zeros and specify the LU alias in the following parameter. To specify the LU associated with the local CP (the default LU), set both *lu\_name* and *lu\_alias* to binary zeros.

### **lu\_alias**

Locally defined LU alias. This is an 8-byte ASCII string, padded on the right with spaces if the name is shorter than 8 bytes. This parameter is used only if *lu\_name* is set to 8 binary zeros; it is ignored otherwise. To specify the LU associated with the local CP (the default LU), set both *lu\_name* and *lu\_alias* to binary zeros.

### **conv\_id**

Identifier of the conversation for which information is required, or the conversation ID to be used as an index into the list of conversations. The conversation ID was returned by the ALLOCATE verb in the invoking TP, or by the RECEIVE\_ALLOCATE verb in the invoked TP.

This parameter is ignored if *list\_options* is set to AP\_FIRST\_IN\_LIST.



**session\_id**

8-byte identifier of the session. To list only information about conversations associated with a specific session, specify the session identifier. To obtain a complete list for all sessions, set this field to binary zeros.

## Returned parameters: successful execution

If the verb executes successfully, CS/AIX returns the following parameters:

**primary\_rc**

AP\_OK

**buf\_size**

Length of the information returned in the supplied buffer.

**total\_buf\_size**

Returned value indicating the size of buffer that would have been required to return all the list information requested. A value greater than *buf\_size* indicates that not all the available entries were returned.

**num\_entries**

Number of entries returned in the data buffer.

**total\_num\_entries**

Total number of entries available. A value greater than *num\_entries* indicates that not all the available entries were returned.

Each entry in the data buffer consists of the following parameters:

**conv\_summary.overlay\_size**

The size of the returned *conv\_summary* structure, and therefore the offset to the start of the next entry in the data buffer.

When your application needs to go through the returned buffer to find each *conv\_summary* structure in turn, it must use this value to move to the correct offset for the next data structure, and must not use the C `sizeof()` operator. This is because the size of the returned overlay may increase in future releases of CS/AIX; using the returned overlay size ensures that your application will continue to work with future releases.

**conv\_summary.conv\_id**

Conversation identifier. The conversation ID was returned by the ALLOCATE verb in the invoking TP, or by the RECEIVE\_ALLOCATE verb in the invoked TP.

**conv\_summary.local\_tp\_name**

The name of the local TP in the conversation.

**conv\_summary.partner\_tp\_name**

The name of the partner TP in the conversation. This parameter is returned only if the conversation was started by the local TP; it is reserved if the conversation was started by the remote TP.

**conv\_summary.tp\_id**

The TP identifier of the conversation.

**conv\_summary.session\_id**

The session identifier of the session allocated to the conversation.

**conv\_summary.conv\_start\_time**

The elapsed time in hundredths of seconds between the time when the CS/AIX node was started and the time when the conversation was started.

**conv\_summary.bytes\_sent**

The number of bytes that have been sent from the local TP to the partner TP since the start of the conversation.

**conv\_summary.bytes\_received**

The number of bytes that have been received from the partner TP by the local TP since the start of the conversation.

### ***conv\_summary.conv\_state***

The current state of the conversation. Values for a half-duplex conversation:

- AP\_CONFIRM\_STATE
- AP\_CONFIRM\_DEALL\_STATE
- AP\_CONFIRM\_SEND\_STATE
- AP\_END\_CONV\_STATE
- AP\_PEND\_DEALL\_STATE
- AP\_PEND\_POST\_STATE
- AP\_POST\_ON\_RECEIPT\_STATE
- AP\_RECEIVE\_STATE
- AP\_RESET\_STATE
- AP\_SEND\_STATE
- AP\_SEND\_PENDING\_STATE

Values for a full-duplex conversation:

- AP\_RESET\_STATE
- AP\_SEND\_ONLY\_STATE
- AP\_SEND\_RECEIVE\_STATE
- AP\_RECEIVE\_ONLY\_STATE

### ***conv\_summary.duplex\_type***

The duplex type of the conversation. Values:

- AP\_HALF\_DUPLEX
- AP\_FULL\_DUPLEX

## Returned parameters: parameter check

If the verb does not execute because of a parameter error, CS/AIX returns the following parameters:

### ***primary\_rc***

AP\_PARAMETER\_CHECK

### ***secondary\_rc***

Possible values are:

#### **AP\_BAD\_CONV\_ID**

The *list\_options* parameter was set to AP\_LIST\_INCLUSIVE to list all entries starting from the supplied value, but the *conv\_id* parameter was not valid.

#### **AP\_INVALID\_LU\_ALIAS**

The specified *lu\_alias* parameter was not valid.

#### **AP\_INVALID\_LU\_NAME**

The specified *lu\_name* parameter was not valid.

#### **AP\_INVALID\_LIST\_OPTION**

The *list\_options* parameter was not set to a valid value.

Appendix B, “Common return codes,” on page 661 lists further secondary return codes associated with AP\_PARAMETER\_CHECK, which are common to all NOF verbs.

## Returned parameters: other conditions

Appendix B, “Common return codes,” on page 661 lists further combinations of primary and secondary return codes that are common to all NOF verbs.

## QUERY\_COS

QUERY\_COS returns route calculation information for a specific class of service (COS).

This verb can be used to obtain information about a specific COS or about multiple COSs, depending on the options used.

### VCB structure

```
typedef struct query_cos
{
    AP_UINT16      opcode;                /* verb operation code          */
    unsigned char  reserv2;               /* reserved                     */
    unsigned char  format;               /* reserved                     */
    AP_UINT16      primary_rc;           /* primary return code          */
    AP_UINT32      secondary_rc;         /* secondary return code        */
    unsigned char  *buf_ptr;             /* pointer to buffer            */
    AP_UINT32      buf_size;             /* buffer size                  */
    AP_UINT32      total_buf_size;       /* total buffer size required   */
    AP_UINT16      num_entries;          /* number of entries            */
    AP_UINT16      total_num_entries;    /* total number of entries      */
    unsigned char  list_options;         /* listing options              */
    unsigned char  reserv3;             /* reserved                     */
    unsigned char  cos_name[8];          /* cos name                     */
} QUERY_COS;
```

```
typedef struct cos_data
{
    AP_UINT16      overlay_size;          /* size of returned entry      */
    unsigned char  cos_name[8];           /* cos name                    */
    unsigned char  description[32];       /* resource description         */
    unsigned char  reserv1[16];           /* reserved                    */
    unsigned char  transmission_priority; /* transmission priority        */
    AP_UINT16      num_of_node_rows;      /* number of node rows         */
    AP_UINT16      num_of_tg_rows;        /* number of tg rows           */
    AP_UINT32      trees;                 /* number of tree caches for COS */
    AP_UINT32      calcs;                 /* number of route calculations */
    AP_UINT32      rejs;                  /* number of route rejects for  */
    unsigned char  reserva[20];           /* reserved                    */
} COS_DATA;
```

### Supplied parameters

The application supplies the following parameters:

#### **opcode**

AP\_QUERY\_COS

#### **buf\_ptr**

A pointer to a data buffer that CS/AIX will use to return the requested information.

#### **buf\_size**

Size of the supplied data buffer.

#### **num\_entries**

Maximum number of COSs for which data should be returned. To request data for a specific COS rather than a range, specify the value 1. To return as many entries as possible, specify zero; in this case, CS/AIX will return the maximum number of entries that can be accommodated in the supplied data buffer.

#### **list\_options**

The position in the list of COSs from which CS/AIX should begin to return data. Possible values are:

##### **AP\_FIRST\_IN\_LIST**

Start at the first entry in the list.

##### **AP\_LIST\_INCLUSIVE**

Start at the entry specified by the *cos\_name* parameter.

**AP\_LIST\_FROM\_NEXT**

Start at the entry immediately following the entry specified by the *cos\_name* parameter.

For more information about how the list is ordered and how the application can obtain specific entries from it, see [“List options for QUERY\\_\\* Verbs”](#) on page 33.

**cos\_name**

Class of service name for which data is required, or the name to be used as an index into the list. This value is ignored if *list\_options* is set to AP\_FIRST\_IN\_LIST. The name is an 8-byte type-A EBCDIC string (starting with a letter), padded on the right with EBCDIC spaces if the name is shorter than 8 characters.

**Returned parameters: successful execution**

If the verb executes successfully, CS/AIX returns the following parameters:

**primary\_rc**

AP\_OK

**buf\_size**

Length of the information returned in the supplied buffer.

**total\_buf\_size**

Returned value indicating the size of buffer that would have been required to return all the list information requested. A value greater than *buf\_size* indicates that not all the available entries were returned.

**num\_entries**

Number of entries returned in the data buffer.

**total\_num\_entries**

Total number of entries available. A value greater than *num\_entries* indicates that not all the available entries were returned.

Each entry in the data buffer consists of the following parameters:

**cos\_data.overlay\_size**

The size of the returned *cos\_data* structure, and therefore the offset to the start of the next entry in the data buffer.

When your application needs to go through the returned buffer to find each *cos\_data* structure in turn, it must use this value to move to the correct offset for the next data structure, and must not use the C `sizeof()` operator. This is because the size of the returned overlay may increase in future releases of CS/AIX; using the returned overlay size ensures that your application will continue to work with future releases.

**cos\_data.cos\_name**

Class of service name. This is an 8-byte alphanumeric type-A EBCDIC string (starting with a letter), padded on the right with EBCDIC spaces.

**cos\_data.description**

A null-terminated text string describing the COS, as specified in the definition of the COS.

**cos\_data.transmission\_priority**

Transmission priority. Possible values are:

AP\_LOW

AP\_MEDIUM

AP\_HIGH

AP\_NETWORK (the highest priority)

**cos\_data.num\_of\_node\_rows**

Number of node rows defined for this COS.

**cos\_data.num\_of\_tg\_rows**

Number of TG rows defined for this COS.

**cos\_data.trees**

Number of route tree caches built for this COS since the last initialization.

**cos\_data.calcs**

Number of session activation requests (and therefore route calculations) specifying this class of service.

**cos\_data.rejs**

Number of session activation requests that failed because there was no acceptable route from this node to the named destination through the network. A route is only acceptable if it is made up entirely of active TGs and nodes that can provide the specified class of service.

## Returned parameters: parameter check

If the verb does not execute because of a parameter error, CS/AIX returns the following parameters:

**primary\_rc**

AP\_PARAMETER\_CHECK

**secondary\_rc**

Possible values are:

**AP\_INVALID\_COS\_NAME**

The *list\_options* parameter was set to AP\_LIST\_INCLUSIVE, to list all entries starting from the supplied name, but the *cos\_name* parameter was not valid.

**AP\_INVALID\_LIST\_OPTION**

The *list\_options* parameter was not set to a valid value.

Appendix B, “Common return codes,” on page 661 lists further secondary return codes associated with AP\_PARAMETER\_CHECK, which are common to all NOF verbs.

## Returned parameters: other conditions

Appendix B, “Common return codes,” on page 661 lists further combinations of primary and secondary return codes that are common to all NOF verbs.

## QUERY\_COS\_NODE\_ROW

QUERY\_COS\_NODE\_ROW returns node row information for a specified class of service as previously defined by DEFINE\_COS (or implicitly by the node for the SNA-defined COSs).

This verb can be used to obtain information about a specific COS node row, or about multiple COS node rows, depending on the options used.

## VCB structure

```
typedef struct query_cos_node_row
{
    AP_UINT16          opcode;           /* verb operation code          */
    unsigned char     reserv2;          /* reserved                      */
    unsigned char     format;           /* reserved                      */
    AP_UINT16         primary_rc;       /* primary return code          */
    AP_UINT32         secondary_rc;     /* secondary return code        */
    unsigned char     *buf_ptr;         /* pointer to buffer            */
    AP_UINT32         buf_size;         /* buffer size                   */
    AP_UINT32         total_buf_size;   /* total buffer size required   */
    AP_UINT16         num_entries;      /* number of entries            */
    AP_UINT16         total_num_entries; /* total number of entries      */
    unsigned char     list_options;     /* listing options              */
    unsigned char     reserv3;          /* reserved                      */
    unsigned char     cos_name[8];      /* cos name                      */
    AP_UINT16         node_row_index;   /* node row index               */
} QUERY_COS_NODE_ROW;
```

## QUERY\_COS\_NODE\_ROW

```
typedef struct cos_node_row_data
{
    AP_UINT16      overlay_size;          /* size of returned entry    */
    unsigned char  cos_name[8];          /* cos name                  */
    AP_UINT16      node_row_index;       /* node row index            */
    COS_NODE_ROW   node_row;             /* cos node row information  */
} COS_NODE_ROW_DATA;
```

```
typedef struct cos_node_row
{
    COS_NODE_STATUS minimum;            /* minimum                   */
    COS_NODE_STATUS maximum;           /* maximum                   */
    unsigned char   weight;             /* weight                    */
    unsigned char   reserv1;           /* reserved                  */
} COS_NODE_ROW;
```

```
typedef struct cos_node_status
{
    unsigned char   rar;                /* route additional resistance */
    unsigned char   status;             /* node status                */
    unsigned char   reserv1[2];        /* reserved                   */
} COS_NODE_STATUS;
```

## Supplied parameters

The application supplies the following parameters:

### ***opcode***

AP\_QUERY\_COS\_NODE\_ROW

### ***buf\_ptr***

A pointer to a data buffer that CS/AIX will use to return the requested information.

### ***buf\_size***

Size of the supplied data buffer.

### ***num\_entries***

Maximum number of COS node rows for which data should be returned. To request data for a specific COS node row rather than a range, specify the value 1. To return as many entries as possible, specify zero; in this case, CS/AIX will return the maximum number of entries that can be accommodated in the supplied data buffer.

### ***list\_options***

The position in the list of COS node rows from which CS/AIX should begin to return data. Possible values are:

#### **AP\_FIRST\_IN\_LIST**

Start at the first entry in the list.

#### **AP\_LIST\_INCLUSIVE**

Start at the entry specified by the combination of the *cos\_name* and *node\_row\_index* parameters.

#### **AP\_LIST\_FROM\_NEXT**

Start at the entry immediately following the entry specified by the combination of the *cos\_name* and *node\_row\_index* parameters.

The list is ordered by *cos\_name*, and then by *node\_row\_index* for each COS. For more information about how the application can obtain specific entries from the list, see [“List options for QUERY\\_\\* Verbs”](#) on page 33.

### ***cos\_name***

Class of service name for which node row information is required, or the name to be used as an index into the list. This value is ignored if *list\_options* is set to AP\_FIRST\_IN\_LIST. The name is an 8-byte type-A EBCDIC string (starting with a letter), padded on the right with EBCDIC spaces if the name is shorter than 8 characters.

**node\_row\_index**

Node row number for which information is required, or the number to be used as an index into the list. This value is ignored if *list\_options* is set to AP\_FIRST\_IN\_LIST. Use QUERY\_COS to determine the number of node rows associated with this COS.

**Returned parameters: successful execution**

If the verb executes successfully, CS/AIX returns the following parameters:

**primary\_rc**

AP\_OK

**buf\_size**

Length of the information returned in the supplied buffer.

**total\_buf\_size**

Returned value indicating the size of buffer that would have been required to return all the list information requested. A value greater than *buf\_size* indicates that not all the available entries were returned.

**num\_entries**

Number of entries returned in the data buffer.

**total\_num\_entries**

Total number of entries available. A value greater than *num\_entries* indicates that not all the available entries were returned.

Each entry in the data buffer consists of the following parameters:

**cos\_node\_row\_data.overlay\_size**

The size of the returned *cos\_node\_row\_data* structure, and therefore the offset to the start of the next entry in the data buffer.

When your application needs to go through the returned buffer to find each *cos\_node\_row\_data* structure in turn, it must use this value to move to the correct offset for the next data structure, and must not use the C `sizeof()` operator. This is because the size of the returned overlay may increase in future releases of CS/AIX; using the returned overlay size ensures that your application will continue to work with future releases.

**cos\_node\_row\_data.cos\_name**

Class of service name. This is an 8-byte type-A EBCDIC string (starting with a letter), padded on the right with EBCDIC spaces if the name is shorter than 8 characters.

**cos\_node\_row\_data.node\_row\_index**

Node row index.

**cos\_node\_row\_data.node\_row.minimum.rar**

Route additional resistance minimum, in the range 0-255.

**cos\_node\_row\_data.node\_row.minimum.status**

Specifies the minimum congestion status of the node. This parameter may be set to AP\_UNCONGESTED, to any one of the other values listed, or to two or more of the other values combined using a logical OR. Possible values are:

**AP\_UNCONGESTED**

The number of ISR sessions is below the *isr\_sessions\_upper\_threshold* value in the node's configuration.

**AP\_CONGESTED**

The number of ISR sessions exceeds the threshold value.

**AP\_IRR\_DEPLETED**

The number of ISR sessions has reached the maximum specified for the node.

**AP\_ERR\_DEPLETED**

The number of endpoint sessions has reached the maximum specified.

## QUERY\_COS\_TG\_ROW

### **AP\_QUIESCING**

A STOP\_NODE of type AP\_QUIESCE or AP\_QUIESCE\_ISR has been issued.

### ***cos\_node\_row\_data.node\_row.maximum.rar***

Route additional resistance maximum, in the range 0-255.

### ***cos\_node\_row\_data.node\_row.maximum.status***

Specifies the maximum congestion status of the node. This parameter may be set to AP\_UNCONGESTED, to any one of the other values listed, or to two or more of the other values combined using a logical OR. Possible values are:

### **AP\_UNCONGESTED**

The number of ISR sessions is below the *isr\_sessions\_upper\_threshold* value in the node's configuration.

### **AP\_CONGESTED**

The number of ISR sessions exceeds the threshold value.

### **AP\_IRR\_DEPLETED**

The number of ISR sessions has reached the maximum specified for the node.

### **AP\_ERR\_DEPLETED**

The number of endpoint sessions has reached the maximum specified.

### **AP\_QUIESCING**

A STOP\_NODE of type AP\_QUIESCE or AP\_QUIESCE\_ISR has been issued.

### ***cos\_node\_row\_data.node\_row.weight***

Weight associated with this node row.

## Returned parameters: parameter check

If the verb does not execute because of a parameter error, CS/AIX returns the following parameters:

### ***primary\_rc***

AP\_PARAMETER\_CHECK

### ***secondary\_rc***

Possible values are:

### **AP\_INVALID\_COS\_NAME**

The *list\_options* parameter was set to AP\_LIST\_INCLUSIVE, to list all entries starting from the supplied name, but the *cos\_name* parameter was not valid.

### **AP\_INVALID\_LIST\_OPTION**

The *list\_options* parameter was not set to a valid value.

Appendix B, “[Common return codes](#),” on page 661 lists further secondary return codes associated with AP\_PARAMETER\_CHECK, which are common to all NOF verbs.

## Returned parameters: other conditions

Appendix B, “[Common return codes](#),” on page 661 lists further combinations of primary and secondary return codes that are common to all NOF verbs.

## QUERY\_COS\_TG\_ROW

---

QUERY\_COS\_TG\_ROW returns TG row information for a specified class of service as previously defined by DEFINE\_COS (or implicitly by the node for the SNA-defined COSs).

This verb can be used to obtain information about a specific COS TG row, or about multiple COS TG rows, depending on the options used.



## VCB structure

```
typedef struct query_cos_tg_row
{
    AP_UINT16      opcode;           /* verb operation code      */
    unsigned char  reserv2;         /* reserved                  */
    unsigned char  format;          /* reserved                  */
    AP_UINT16      primary_rc;      /* primary return code      */
    AP_UINT32      secondary_rc;    /* secondary return code    */
    unsigned char  *buf_ptr;        /* pointer to buffer        */
    AP_UINT32      buf_size;        /* buffer size              */
    AP_UINT32      total_buf_size;  /* total buffer size required */
    AP_UINT16      num_entries;     /* number of entries        */
    AP_UINT16      total_num_entries; /* total number of entries  */
    unsigned char  list_options;    /* listing options          */
    unsigned char  reserv3;         /* reserved                  */
    unsigned char  cos_name[8];     /* cos name                  */
    AP_UINT16      tg_row_index;    /* TG row index             */
} QUERY_COS_TG_ROW;
```

```
typedef struct cos_tg_row_data
{
    AP_UINT16      overlay_size;    /* size of returned entry   */
    unsigned char  cos_name[8];     /* cos name                  */
    AP_UINT16      tg_row_index;    /* TG row index             */
    COS_TG_ROW     tg_row;          /* TG row information       */
} COS_TG_ROW_DATA;
```

```
typedef struct cos_tg_row
{
    TG_DEFINED_CHARS minimum;      /* minimum                  */
    TG_DEFINED_CHARS maximum;      /* maximum                  */
    unsigned char    weight;        /* weight                   */
    unsigned char    reserv1;       /* reserved                  */
} COS_TG_ROW;
```

```
typedef struct tg_defined_chars
{
    unsigned char    effect_cap;     /* Effective capacity       */
    unsigned char    reserve1[5];    /* Reserved                  */
    unsigned char    connect_cost;  /* Connection Cost          */
    unsigned char    byte_cost;     /* Byte cost                */
    unsigned char    reserve2;       /* Reserved                  */
    unsigned char    security;       /* Security                  */
    unsigned char    prop_delay;     /* Propagation delay        */
    unsigned char    modem_class;    /* reserved                  */
    unsigned char    user_def_parm_1; /* User-defined parameter 1 */
    unsigned char    user_def_parm_2; /* User-defined parameter 2 */
    unsigned char    user_def_parm_3; /* User-defined parameter 3 */
} TG_DEFINED_CHARS;
```

## Supplied parameters

The application supplies the following parameters:

### **opcode**

AP\_QUERY\_COS\_TG\_ROW

### **buf\_ptr**

A pointer to a data buffer that CS/AIX will use to return the requested information.

### **buf\_size**

Size of the supplied data buffer.

### **num\_entries**

Maximum number of COS TG rows for which data should be returned. To request data for a specific COS TG row rather than a range, specify the value 1. To return as many entries as possible, specify zero; in this case, CS/AIX will return the maximum number of entries that can be accommodated in the supplied data buffer.

***list\_options***

The position in the list of COS TG rows from which CS/AIX should begin to return data. Possible values are:

**AP\_FIRST\_IN\_LIST**

Start at the first entry in the list.

**AP\_LIST\_INCLUSIVE**

Start at the entry specified by the combination of the *cos\_name* and *tg\_row\_index* parameters.

**AP\_LIST\_FROM\_NEXT**

Start at the entry immediately following the entry specified by the combination of the *cos\_name* and *tg\_row\_index* parameters.

The list is ordered by *cos\_name*, and then by *tg\_row\_index* for each COS. For more information about how the list is ordered and how the application can obtain specific entries from it, see [“List options for QUERY\\_\\* Verbs”](#) on page 33.

***cos\_name***

Class of service name for which data is required, or the name to be used as an index into the list. The name is an 8-byte type-A EBCDIC string (starting with a letter), padded on the right with EBCDIC spaces if the name is shorter than 8 characters. This parameter is ignored if *list\_options* is set to AP\_FIRST\_IN\_LIST.

***tg\_row\_index***

TG row number for which data is required, or the number to be used as an index into the list (the first row has an index of zero). This parameter is ignored if *list\_options* is set to AP\_FIRST\_IN\_LIST.

## Returned parameters: successful execution

If the verb executes successfully, CS/AIX returns the following parameters:

***primary\_rc***

AP\_OK

***buf\_size***

Length of the information returned in the supplied buffer.

***total\_buf\_size***

Returned value indicating the size of buffer that would have been required to return all the list information requested. A value greater than *buf\_size* indicates that not all the available entries were returned.

***num\_entries***

Number of entries returned in the data buffer.

***total\_num\_entries***

Total number of entries available. A value greater than *num\_entries* indicates that not all the available entries were returned.

Each entry in the data buffer consists of the following parameters:

***cos\_tg\_row\_data.overlay\_size***

The size of the returned *cos\_tg\_row\_data* structure, and therefore the offset to the start of the next entry in the data buffer.

When your application needs to go through the returned buffer to find each *cos\_tg\_row\_data* structure in turn, it must use this value to move to the correct offset for the next data structure, and must not use the C `sizeof()` operator. This is because the size of the returned overlay may increase in future releases of CS/AIX; using the returned overlay size ensures that your application will continue to work with future releases.

***cos\_tg\_row\_data.cos\_name***

Class of service name. This is an 8-byte type-A EBCDIC string (starting with a letter), padded on the right with EBCDIC spaces if the name is shorter than 8 characters.

**cos\_tg\_row\_data.tg\_row\_index**

TG row index (the first row has an index of zero).

**cos\_tg\_row\_data.tg\_row.minimum.effect\_cap**

Minimum limit for actual bits per second rate (line speed). The value is encoded as a 1-byte floating point number, represented by the formula  $0.1 \text{ mmm} * 2^{\text{eeee}}$  where the bit representation of the byte is  $b'eeeeemmm'$ . Each unit of effective capacity is equal to 300 bits per second.

**cos\_tg\_row\_data.tg\_row.minimum.connect\_cost**

Minimum limit for cost per connect time; an integer value in the range 0-255, where 0 is the lowest cost per connect time and 255 is the highest.

**cos\_tg\_row\_data.tg\_row.minimum.byte\_cost**

Minimum limit for cost per byte; an integer value in the range 0-255, where zero is the lowest cost per byte and 255 is the highest.

**cos\_tg\_row\_data.tg\_row.minimum.security**

Minimum level of security. Possible values are:

**AP\_SEC\_NONSECURE**

No security.

**AP\_SEC\_PUBLIC\_SWITCHED\_NETWORK**

Data is transmitted over a public switched network.

**AP\_SEC\_UNDERGROUND\_CABLE**

Data is transmitted over secure underground cable.

**AP\_SEC\_SECURE\_CONDUIT**

Data is transmitted over a line in a secure conduit that is not guarded.

**AP\_SEC\_GUARDED\_CONDUIT**

Data is transmitted over a line in a conduit that is protected against physical tapping.

**AP\_SEC\_ENCRYPTED**

Data is encrypted before transmission over the line.

**AP\_SEC\_GUARDED\_RADIATION**

Data is transmitted over a line that is protected against physical and radiation tapping.

**cos\_tg\_row\_data.tg\_row.minimum.prop\_delay**

Minimum limits for propagation delay: the time that a signal takes to travel the length of the link. Possible values are:

**AP\_PROP\_DELAY\_MINIMUM**

Minimum propagation delay.

**AP\_PROP\_DELAY\_LAN**

Delay is less than 480 microseconds (typical for a LAN). If the verb was issued to a running node, this value will be returned if the DEFINE\_COS specified either AP\_PROP\_DELAY\_LAN or AP\_PROP\_DELAY\_MINIMUM.

**AP\_PROP\_DELAY\_TELEPHONE**

Delay is in the range 480-49,512 microseconds (typical for a telephone network).

**AP\_PROP\_DELAY\_PKT\_SWITCHED\_NET**

Delay is in the range 49,512-245,760 microseconds (typical for a packet-switched network).

**AP\_PROP\_DELAY\_SATELLITE**

Delay is greater than 245,760 microseconds (typical for a satellite link).

**AP\_PROP\_DELAY\_MAXIMUM**

Maximum propagation delay.

**cos\_tg\_row\_data.tg\_row.minimum.user\_def\_parm\_1 through****cos\_tg\_row\_data.tg\_row.minimum.user\_def\_parm\_3**

Minimum values for user-defined parameters, which include other TG characteristics not covered by the above parameters. Each of these parameters is set to a value in the range 0-255.

***cos\_tg\_row\_data.tg\_row.maximum.effect\_cap***

Maximum limit for actual bits per second rate (line speed). The value is encoded as a 1-byte floating point number, represented by the formula  $0.1 \text{ mmm} * 2^{\text{eeeeee}}$  where the bit representation of the byte is eeeeemmm. Each unit of effective capacity is equal to 300 bits per second.

***cos\_tg\_row\_data.tg\_row.maximum.connect\_cost***

Maximum limit for cost per connect time; an integer value in the range 0-255, where 0 is the lowest cost per connect time and 255 is the highest.

***cos\_tg\_row\_data.tg\_row.maximum.byte\_cost***

Maximum limit for cost per byte; an integer value in the range 0-255, where 0 is the lowest cost per byte and 255 is the highest.

***cos\_tg\_row\_data.tg\_row.maximum.security***

Maximum level of security. Possible values are:

**AP\_SEC\_NONSECURE**

No security.

**AP\_SEC\_PUBLIC\_SWITCHED\_NETWORK**

Data is transmitted over a public switched network.

**AP\_SEC\_UNDERGROUND\_CABLE**

Data is transmitted over secure underground cable.

**AP\_SEC\_SECURE\_CONDUIT**

Data is transmitted over a line in a secure conduit that is not guarded.

**AP\_SEC\_GUARDED\_CONDUIT**

Data is transmitted over a line in a conduit that is protected against physical tapping.

**AP\_SEC\_ENCRYPTED**

Data is encrypted before transmission over the line.

**AP\_SEC\_GUARDED\_RADIATION**

Data is transmitted over a line that is protected against physical and radiation tapping.

**AP\_SEC\_MAXIMUM**

Maximum security.

***cos\_tg\_row\_data.tg\_row.maximum.prop\_delay***

Maximum limits for propagation delay: the time that a signal takes to travel the length of the link. Possible values are:

**AP\_PROP\_DELAY\_MINIMUM**

Minimum propagation delay.

**AP\_PROP\_DELAY\_LAN**

Delay is less than 480 microseconds (typical for a LAN).

**AP\_PROP\_DELAY\_TELEPHONE**

Delay is in the range 480-49,512 microseconds (typical for a telephone network).

**AP\_PROP\_DELAY\_PKT\_SWITCHED\_NET**

Delay is in the range 49,512-245,760 microseconds (typical for a packet-switched network).

**AP\_PROP\_DELAY\_SATELLITE**

Delay is greater than 245,760 microseconds (typical for a satellite link). If the verb was issued to a running node, this value will be returned if the DEFINE\_COS specified either AP\_PROP\_DELAY\_SATELLITE or AP\_PROP\_DELAY\_MAXIMUM.

**AP\_PROP\_DELAY\_MAXIMUM**

Maximum propagation delay.

***cos\_tg\_row\_data.tg\_row.maximum.user\_def\_parm\_1 through***

***cos\_tg\_row\_data.tg\_row.maximum.user\_def\_parm\_3***

Maximum values for user-defined parameters, which include other TG characteristics not covered by the above parameters. Each of these parameters is set to a value in the range 0-255.

***cos\_tg\_row\_data.tg\_row.weight***

Weight associated with this TG row.

## Returned parameters: parameter check

If the verb does not execute because of a parameter error, CS/AIX returns the following parameters:

### *primary\_rc*

AP\_PARAMETER\_CHECK

### *secondary\_rc*

Possible values are:

#### **AP\_INVALID\_COS\_NAME**

The *list\_options* parameter was set to AP\_LIST\_INCLUSIVE, to list all entries starting from the supplied name, but the *cos\_name* parameter was not valid.

#### **AP\_INVALID\_LIST\_OPTION**

The *list\_options* parameter was not set to a valid value.

Appendix B, “Common return codes,” on page 661 lists further secondary return codes associated with AP\_PARAMETER\_CHECK, which are common to all NOF verbs.

## Returned parameters: other conditions

Appendix B, “Common return codes,” on page 661 lists further combinations of primary and secondary return codes that are common to all NOF verbs.

## QUERY\_CPIC\_SIDE\_INFO

This verb returns the side information entry for a given symbolic destination name, or for multiple symbolic destination names, depending on the options used.

Note the difference between this verb and the CPI-C function Extract\_CPIC\_Side\_Information. This verb queries a configuration file, so that it returns the default information used by all CS/AIX CPI-C applications. The CPI-C function queries the application's own copy in memory of the side information table, which the application may have modified using the other CPI-C side information functions.

This verb must be issued to the domain configuration file.

## VCB structure

```
typedef struct query_cplic_side_info
{
    AP_UINT16          opcode;          /* verb operation code      */
    unsigned char      reserv2;         /* reserved                  */
    unsigned char      format;          /* reserved                  */
    AP_UINT16          primary_rc;      /* primary return code      */
    AP_UINT32          secondary_rc;    /* secondary return code    */
    unsigned char      *buf_ptr;        /* pointer to buffer        */
    AP_UINT32          buf_size;        /* buffer size              */
    AP_UINT32          total_buf_size;  /* total buffer size required */
    AP_UINT16          num_entries;     /* number of entries        */
    AP_UINT16          total_num_entries; /* total number of entries  */
    unsigned char      list_options;    /* listing options          */
    unsigned char      reserv3;         /* reserved                  */
    unsigned char      sym_dest_name[8]; /* Symbolic destination name */
} QUERY_CPIC_SIDE_INFO;
```

```
typedef struct cplic_side_info_data
{
    AP_UINT16          overlay_size;    /* size of returned entry   */
    unsigned char      sym_dest_name[8]; /* Symbolic destination name */
    unsigned char      reserv1[2];     /* reserved                  */
    CPIC_SIDE_INFO_DEF_DATA def_data;
} CPIC_SIDE_INFO_DATA;
```

```
typedef struct cplic_side_info_def_data
{
    unsigned char      description[32]; /* resource description      */
    unsigned char      reserv1[16];    /* reserved                  */
    CPIC_SIDE_INFO     side_info;      /* CPIC side info           */
}
```

## QUERY\_CPIC\_SIDE\_INFO

```
    unsigned char    user_data[24];    /* reserved          */
} CPIC_SIDE_INFO_DEF_DATA;

typedef struct cpic_side_info
{
    unsigned char    partner_lu_name[17];    /* Fully qualified partner LU name */
    unsigned char    reserved[3];          /* Reserved                */
    AP_UINT32        tp_name_type;         /* TP name type            */
    unsigned char    tp_name[64];         /* TP name                  */
    unsigned char    mode_name[8];        /* Mode name                */
    AP_UINT32        conversation_security_type; /* Conversation security type */
    unsigned char    security_user_id[10]; /* User ID                  */
    unsigned char    security_password[10]; /* Password                 */
    unsigned char    lu_alias[8];         /* LU alias                  */
} CPIC_SIDE_INFO;
```

## Supplied parameters

The application supplies the following parameters:

### ***opcode***

AP\_QUERY\_CPIC\_SIDE\_INFO

### ***buf\_ptr***

A pointer to a data buffer that CS/AIX will use to return the requested information.

### ***buf\_size***

Size of the supplied data buffer.

### ***num\_entries***

Maximum number of symbolic destination names for which data should be returned. To request data for a specific symbolic destination name rather than a range, specify the value 1. To return as many entries as possible, specify zero; in this case, CS/AIX will return the maximum number of entries that can be accommodated in the supplied data buffer.

### ***list\_options***

The position in the list of symbolic destination names from which CS/AIX should begin to return data. Possible values are:

#### **AP\_FIRST\_IN\_LIST**

Start at the first entry in the list.

#### **AP\_LIST\_INCLUSIVE**

Start at the entry specified by the *sym\_dest\_name* parameter.

#### **AP\_LIST\_FROM\_NEXT**

Start at the entry immediately following the entry specified by the *sym\_dest\_name* parameter.

For more information about how the list is ordered and how the application can obtain specific entries from it, see [“List options for QUERY\\_\\* Verbs”](#) on page 33.

### ***sym\_dest\_name***

Symbolic destination name for which data is required, or the name to be used as an index into the list. This value is ignored if *list\_options* is set to AP\_FIRST\_IN\_LIST. The name is an ASCII string, consisting of uppercase A-Z and numerals 0-9, padded on the right with spaces if the name is shorter than 8 characters.

## Returned parameters: successful execution

If the verb executes successfully, CS/AIX returns the following parameters:

### ***primary\_rc***

AP\_OK

### ***buf\_size***

Length of the information returned in the supplied buffer.

***total\_buf\_size***

Returned value indicating the size of buffer that would have been required to return all the list information requested. A value greater than *buf\_size* indicates that not all the available entries were returned.

***num\_entries***

Number of entries returned in the data buffer.

***total\_num\_entries***

Total number of entries available. A value greater than *num\_entries* indicates that not all the available entries were returned.

Each entry in the data buffer consists of the following parameters:

***cpic\_side\_info\_data.overlay\_size***

The size of the returned *cpic\_side\_info\_data* structure, and therefore the offset to the start of the next entry in the data buffer.

When your application needs to go through the returned buffer to find each *cpic\_side\_info\_data* structure in turn, it must use this value to move to the correct offset for the next data structure, and must not use the C `sizeof()` operator. This is because the size of the returned overlay may increase in future releases of CS/AIX; using the returned overlay size ensures that your application will continue to work with future releases.

***cpic\_side\_info\_data.sym\_dest\_name***

Symbolic destination name for the returned side information entry.

***cpic\_side\_info\_data.def\_data.description***

A null-terminated text string describing the side information entry, as specified in the definition of the side information entry.

***cpic\_side\_info\_data.def\_data.side\_info.partner\_lu\_name***

Fully qualified name of the partner LU. The name is a 17-byte EBCDIC string, right-padded with EBCDIC spaces. It consists of a network ID of up to 8 A-string characters, an EBCDIC dot (period) character, and a network name of up to 8 A-string characters.

***cpic\_side\_info\_data.def\_data.side\_info.tp\_name\_type***

The type of the target TP (the valid characters for a TP name are determined by the TP type). Possible values are:

**XC\_APPLICATION\_TP**

Application TP. All characters in the TP name must be valid ASCII characters.

**XC\_SNA\_SERVICE\_TP**

Service TP. The TP name must be specified as an 8-character ASCII string representing the hexadecimal digits of a 4-character name. For example, if the hexadecimal representation of the name is 0x21F0F0F8, set the *def\_data.side\_info.tp\_name* parameter to the 8-character string ``21F0F0F8'`.

The first character (represented by two bytes) must be a hexadecimal value in the range 0x0-0x3F, excluding 0x0E and 0x0F; the remaining characters (each represented by two bytes) must be valid EBCDIC characters.

***cpic\_side\_info\_data.def\_data.side\_info.tp\_name***

TP name of the target TP. This is a 64-byte ASCII character string, right-padded with spaces.

***cpic\_side\_info\_data.def\_data.side\_info.mode\_name***

Name of the mode used to access the target TP. This is an 8-byte ASCII character string, right-padded with spaces.

***cpic\_side\_info\_data.def\_data.side\_info.conversation\_security\_type***

Specifies whether the target TP uses conversation security. Possible values are:

**XC\_SECURITY\_NONE**

The target TP does not use conversation security.

### **XC\_SECURITY\_PROGRAM**

The target TP uses conversation security. The *security\_user\_id* and *security\_password* parameters specified below will be used to access the target TP.

### **XC\_SECURITY\_PROGRAM\_STRONG**

As for XC\_SECURITY\_PROGRAM, except that the local node must not send the password across the network in clear text format. This value can be used only if the remote system supports password substitution.

### **XC\_SECURITY\_SAME**

The target TP uses conversation security, and can accept an "already verified" indicator from the local TP. (This indicates that the local TP was itself invoked by another TP, and has verified the security user ID and password supplied by this TP.) The *security\_user\_id* parameter specified below will be used to access the target TP; no password is required.

### ***cpic\_side\_info\_data.def\_data.side\_info.security\_user\_id***

User ID used to access the partner TP. This parameter is not used if the *conversation\_security\_type* parameter is set to XC\_SECURITY\_NONE.

### ***cpic\_side\_info\_data.def\_data.side\_info.security\_password***

Password used to access the partner TP. This parameter is used only if the *conversation\_security\_type* parameter is set to XC\_SECURITY\_PROGRAM or XC\_SECURITY\_PROGRAM\_STRONG.

### ***cpic\_side\_info\_data.def\_data.side\_info.lu\_alias***

The alias of the local LU used to communicate with the target TP. This alias is a character string using any locally displayable characters.

## Returned parameters: parameter check

If the verb does not execute because of a parameter error, CS/AIX returns the following parameters:

### ***primary\_rc***

AP\_PARAMETER\_CHECK

### ***secondary\_rc***

#### **AP\_INVALID\_LIST\_OPTION**

The *list\_options* parameter was not set to a valid value.

Appendix B, "Common return codes," on page 661 lists further secondary return codes associated with AP\_PARAMETER\_CHECK, which are common to all NOF verbs.

## Returned parameters: state check

If the verb does not execute because of a state error, CS/AIX returns the following parameters.

### ***primary\_rc***

AP\_STATE\_CHECK

### ***secondary\_rc***

#### **AP\_INVALID\_SYM\_DEST\_NAME**

The *list\_options* parameter was set to AP\_LIST\_INCLUSIVE, to list all entries starting from the supplied name, but the *sym\_dest\_name* parameter was not valid.

Appendix B, "Common return codes," on page 661 lists further secondary return codes associated with AP\_STATE\_CHECK, which are common to all NOF verbs.

## Returned parameters: other conditions

Appendix B, "Common return codes," on page 661 lists further combinations of primary and secondary return codes that are common to all NOF verbs.



## QUERY\_CS\_TRACE

This verb returns information about the current tracing options for data sent between computers on the CS/AIX LAN. For more information about tracing options, see the *IBM Communications Server for Data Center Deployment on AIX Administration Guide*.

This verb must be issued to a running node.

### VCB structure

```
typedef struct query_cs_trace
{
    AP_UINT16      opcode;           /* verb operation code          */
    unsigned char  reserv2;         /* reserved                      */
    unsigned char  format;         /* reserved                      */
    AP_UINT16      primary_rc;     /* primary return code          */
    AP_UINT32      secondary_rc;   /* secondary return code        */
    unsigned char  dest_sys[128];  /* node to which messages are traced */
    unsigned char  reserv4[4];     /* reserved                      */
    AP_UINT16      trace_flags;    /* trace flags                   */
    AP_UINT16      trace_direction; /* direction (send/rcv/both) to trace */
    unsigned char  reserv3[8];     /* Reserved                      */
} QUERY_CS_TRACE;
```

### Supplied parameters

The application supplies the following parameters:

#### **opcode**

AP\_QUERY\_CS\_TRACE

#### **dest\_sys**

The server name for which tracing options are being queried. This is an ASCII string, padded on the right with spaces if the name is shorter than 128 characters.

To query tracing options on messages flowing between the computer to which this verb is issued (identified by the *target\_handle* parameter on the NOF API call) and one other server on the LAN, specify the name of the other server here.

If the computer name includes a . (period) character, CS/AIX assumes that it is a fully-qualified name; otherwise it performs a DNS lookup to determine the computer name.

To query the default tracing options (set by a SET\_CS\_TRACE verb with no destination system name specified), set this parameter to all ASCII space characters.

### Returned parameters: successful execution

If the verb executes successfully, CS/AIX returns the following parameters:

#### **primary\_rc**

AP\_OK

#### **secondary\_rc**

Not used.

#### **trace\_flags**

The types of tracing currently active. For more information about these trace types, see [“SET\\_CS\\_TRACE” on page 563](#).

If no tracing is active, or if tracing of all types is active, this is one of the following values:

#### **AP\_NO\_TRACE**

No tracing.

#### **AP\_ALL\_TRACE**

Tracing of all types.

## QUERY\_DEFAULT\_PU

If tracing is being used on specific interfaces, this parameter is set to one or more values from the list below, combined using a logical OR operation.

### AP\_CS\_ADMIN\_MSG

Internal messages relating to client/server topology

### AP\_CS\_DATAGRAM

Datagram messages

### AP\_CS\_DATA

Data messages

### *trace\_direction*

Specifies the direction or directions in which tracing is active. This parameter is not used if *trace\_flags* is set to AP\_NO\_TRACE. Possible values are:

### AP\_CS\_SEND

Messages flowing from the target computer to the computer defined by *dest\_sys* are traced.

### AP\_CS\_RECEIVE

Messages flowing from the computer defined by *dest\_sys* to the target computer are traced.

### AP\_CS\_BOTH

Messages flowing in both directions are traced.

## Returned parameters: parameter check

If the verb does not execute because of a parameter error, CS/AIX returns the following parameters:

### *primary\_rc*

AP\_PARAMETER\_CHECK

### *secondary\_rc*

Possible values are:

### AP\_NAME\_NOT\_FOUND

The server specified by the *dest\_sys* parameter did not exist or was not started.

### AP\_LOCAL\_SYSTEM

The server specified by the *dest\_sys* parameter is the same as the target node to which this verb was issued.

### AP\_INVALID\_TARGET

The verb was issued on a standalone server. This verb can only be issued on a client/server system.

Appendix B, “Common return codes,” on page 661 lists further secondary return codes associated with AP\_PARAMETER\_CHECK, which are common to all NOF verbs.

## Returned parameters: other conditions

Appendix B, “Common return codes,” on page 661 lists further combinations of primary and secondary return codes that are common to all NOF verbs.

## QUERY\_DEFAULT\_PU

---

QUERY\_DEFAULT\_PU allows the user to query the default PU (defined using DEFINE\_DEFAULT\_PU).

## VCB structure

```
typedef struct query_default_pu
{
    AP_UINT16      opcode;           /* verb operation code          */
    unsigned char  reserv2;         /* reserved                     */
    unsigned char  format;          /* reserved                     */
    AP_UINT16      primary_rc;      /* primary return code          */
    AP_UINT32      secondary_rc;    /* secondary return code        */
}
```

```

unsigned char  def_pu_name[8];      /* default PU name          */
unsigned char  description[32];    /* resource description     */
unsigned char  reserv1[16];        /* reserved                  */
unsigned char  def_pu_sess[8];     /* PU name of active default session */
unsigned char  reserv3[16];        /* reserved                  */
} QUERY_DEFAULT_PU;

```

## Supplied parameters

The application supplies the following parameters:

### *opcode*

AP\_QUERY\_DEFAULT\_PU

## Returned parameters: successful execution

If the verb executes successfully, CS/AIX returns the following parameters:

### *primary\_rc*

AP\_OK

### *def\_pu\_name*

Name of the PU specified on the most recent DEFINE\_DEFAULT\_PU verb. This is an 8-byte type-A EBCDIC string (starting with a letter), padded on the right with EBCDIC spaces. If this field is set to all binary zeros, this indicates that no DEFINE\_DEFAULT\_PU verb has been issued or that the default PU has been deleted by issuing a DEFINE\_DEFAULT\_PU verb with the *pu\_name* parameter specified as all zeros.

### *description*

A null-terminated text string describing the default PU, as specified in the definition of the default PU.

### *def\_pu\_sess*

Name of the PU associated with the currently active default PU session.

This parameter normally contains the same value as the *def\_pu\_name* field. However, if a default PU has been defined, but the session associated with it is not active, CS/AIX continues to use the session associated with the previous default PU until the session associated with the defined default PU becomes active. In this case, this parameter specifies the name of the previous default PU, and is different from the *def\_pu\_name* field.

If there are no active PU sessions, this field will be set to all binary zeros.

## Returned parameters: node not started

If the verb does not execute because the node has not yet been started, CS/AIX returns the following parameters:

### *primary\_rc*

AP\_NODE\_NOT\_STARTED

## Returned parameters: other conditions

Appendix B, “Common return codes,” on page 661 lists further combinations of primary and secondary return codes that are common to all NOF verbs.

## QUERY\_DEFAULTS

QUERY\_DEFAULTS allows the user to query the default parameters defined for the node (defined using DEFINE\_DEFAULTS).

## VCB structure

```

typedef struct query_defaults
{

```

## QUERY\_DEFAULTS

```
    AP_UINT16      opcode;          /* verb operation code      */
    unsigned char  reserv2;         /* reserved                  */
    unsigned char  format;         /* reserved                  */
    AP_UINT16      primary_rc;     /* primary return code      */
    AP_UINT32      secondary_rc;   /* secondary return code    */
    DEFAULT_CHARS  default_chars;  /* default parameters       */
} QUERY_DEFAULTS;
```

```
typedef struct default_chars
{
    unsigned char  description[32]; /* resource description      */
    unsigned char  reserv2[16];    /* reserved                  */
    unsigned char  mode_name[8];   /* default mode name        */
    unsigned char  implicit_plu_forbidden; /* disallow implicit PLUs? */
    unsigned char  specific_security_codes; /*generic security sensecodes?*/
    AP_UINT16      limited_timeout; /* timeout for limited sessions */
    unsigned char  reserv[244];    /* reserved                  */
} DEFAULT_CHARS;
```

## Supplied parameters

The application supplies the following parameter:

### ***opcode***

AP\_QUERY\_DEFAULTS

## Returned parameters: successful execution

If the verb executes successfully, CS/AIX returns the following parameters:

### ***primary\_rc***

AP\_OK

### ***default\_chars.description***

A null-terminated text string describing the default parameters, as specified in DEFINE\_DEFAULTS.

### ***default\_chars.mode\_name***

Name of the default mode. If an application specifies an unrecognized mode name when attempting to start a session, the parameters from this mode will be used as a default definition for the unrecognized mode.

The mode name is an 8-byte type-A EBCDIC string. If no default mode name has been specified using the DEFINE\_DEFAULTS verb, this parameter is set to 8 binary zeros.

### ***default\_chars.implicit\_plu\_forbidden***

Indicates whether CS/AIX puts implicit definitions in place for unknown partner LUs. Possible values are:

#### **AP\_YES**

CS/AIX does not put implicit definitions in place for unknown partner LUs. All partner LUs must be defined explicitly.

#### **AP\_NO**

CS/AIX puts implicit definitions in place for unknown partner LUs.

### ***default\_chars.specific\_security\_codes***

Indicates whether CS/AIX uses specific sense codes on a security authentication or authorization failure. Specific sense codes are only returned to those partner LUs which have reported support for them on the session. Possible values are:

#### **AP\_YES**

CS/AIX uses specific sense codes.

#### **AP\_NO**

CS/AIX does not use specific sense codes.

### ***default\_chars.limited\_timeout***

Specifies the timeout after which free limited-resource conwinner sessions are deactivated. The range is 0-65,535 seconds.

## Returned parameters: node not started

If the verb does not execute because the node has not yet been started, CS/AIX returns the following parameter:

```
primary_rc
    AP_NODE_NOT_STARTED
```

## Returned parameters: other conditions

Appendix B, “Common return codes,” on page 661 lists further combinations of primary and secondary return codes that are common to all NOF verbs.

## QUERY\_DIRECTORY\_ENTRY

QUERY\_DIRECTORY\_ENTRY returns information about resources in the directory database. It can return either summary or detailed information, about a specific resource or multiple resources, depending on the options used.

If the verb is issued to a running node, it returns information both on resources that have been defined explicitly (using DEFINE\_DIRECTORY\_ENTRY, or DEFINE\_ADJACENT\_LEN\_NODE) and on resources that have been located dynamically. If the node is not running, only explicitly defined entries are returned.

When the verb is issued to an end node, the directory contains only information about the end node and its resources, and not about other nodes. The first entry returned is for the end node itself, followed by its LUs. (No entry is returned for the end node's network node server.)

When the verb is issued to a network node, the directory may contain information about multiple network nodes and their associated end nodes and LUs. For each network node, the information returned is in the following order:

1. The network node.
2. The LUs owned by this node.
3. The first end node associated with the network node.
4. The LUs owned by this end node.
5. Any other end nodes associated with the network node, each followed by its LUs.

## VCB structure

```
typedef struct query_directory_entry
{
    AP_UINT16      opcode;           /* verb operation code          */
    unsigned char  reserv2;         /* reserved                      */
    unsigned char  format;         /* reserved                      */
    AP_UINT16      primary_rc;      /* primary return code          */
    AP_UINT32      secondary_rc;    /* secondary return code        */
    unsigned char  *buf_ptr;       /* pointer to buffer            */
    AP_UINT32      buf_size;       /* buffer size                  */
    AP_UINT32      total_buf_size; /* total buffer size required   */
    AP_UINT16      num_entries;     /* number of entries            */
    AP_UINT16      total_num_entries; /* total number of entries      */
    unsigned char  list_options;   /* listing options              */
    unsigned char  reserv3;        /* reserved                      */
    unsigned char  resource_name[17]; /* network qualified resource  */
                                     /* name                          */
    unsigned char  reserv4;        /* reserved                      */
    AP_UINT16      resource_type;   /* Resource type                */
    unsigned char  parent_name[17]; /* parent name filter           */
    unsigned char  reserv5;        /* reserved                      */
    AP_UINT16      parent_type;    /* parent type                  */
    unsigned char  reserv6[24];    /* reserved                      */
} QUERY_DIRECTORY_ENTRY;
```

```
typedef struct directory_entry_summary
{
    AP_UINT16      overlay_size;    /* size of this entry           */
}
```

## QUERY\_DIRECTORY\_ENTRY

```
    unsigned char    resource_name[17];    /* network qualified resource */
    unsigned char    reserve1;            /* name */
    AP_UINT16        resource_type;        /* reserved */
    unsigned char    description[32];      /* Resource type */
    unsigned char    reserv1[16];         /* resource description */
    AP_UINT16        real_owning_cp_type;  /* reserved */
    unsigned char    real_owning_cp_name[17]; /* CP type of real owner */
    unsigned char    reserve2;            /* CP name of real owner */
} DIRECTORY_ENTRY_SUMMARY;                /* reserved */
```

```
typedef struct directory_entry_detail
{
    AP_UINT16        overlay_size;        /* size of this entry */
    unsigned char    resource_name[17];    /* network qualified res name */
    unsigned char    reserv1a;            /* reserved */
    AP_UINT16        resource_type;        /* Resource type */
    unsigned char    description[32];      /* resource description */
    unsigned char    reserv2[16];         /* reserved */
    unsigned char    parent_name[17];     /* Network qualified parent name */
    unsigned char    reserv1b;            /* reserved */
    AP_UINT16        parent_type;         /* Parent resource type */
    unsigned char    entry_type;          /* Type of the directory entry */
    unsigned char    location;            /* Resource location */
    AP_UINT16        real_owning_cp_type;  /* CP type of real owner */
    unsigned char    real_owning_cp_name[17]; /* CP name of real owner */
    unsigned char    reserv1c;            /* reserved */
    AP_UINT16        supplier_cp_type;    /* CP type of supplier */
    unsigned char    supplier_cp_name[17]; /* CP name of supplier */
    unsigned char    reserva;             /* reserved */
} DIRECTORY_ENTRY_DETAIL;
```

## Supplied parameters

The application supplies the following parameters:

### ***opcode***

AP\_QUERY\_DIRECTORY\_ENTRY

### ***buf\_ptr***

A pointer to a data buffer that CS/AIX will use to return the requested information.

### ***buf\_size***

Size of the supplied data buffer.

### ***num\_entries***

Maximum number of resources for which data should be returned. To request data for a specific resource rather than a range, specify the value 1. To return as many entries as possible, specify zero; in this case, CS/AIX will return the maximum number of entries that can be accommodated in the supplied data buffer.

### ***list\_options***

The position in the list from which CS/AIX should begin to return data, and the level of information required for each entry. Specify the level of information with one of the following values:

#### **AP\_SUMMARY**

Summary information only.

#### **AP\_DETAIL**

Detailed information.

Combine this value using a logical OR operation with one of the following values:

#### **AP\_FIRST\_IN\_LIST**

Start at the first entry in the list.

#### **AP\_LIST\_INCLUSIVE**

Start at the entry specified by the combination of the *parent\_name*, *resource\_name*, and *resource\_type* parameters.

**AP\_LIST\_FROM\_NEXT**

Start at the entry immediately following the entry specified by the combination of the *parent\_name*, *resource\_name*, and *resource\_type* parameters.

The list is ordered by *parent\_name*, then by *resource\_name*, and lastly by *resource\_type*. For more information about how the list is ordered and how the application can obtain specific entries from it, see “List options for QUERY\_\* Verbs” on page 33.

**resource\_name**

Fully qualified name of the resource for which information is required, or the name to be used as an index into the list of resources. This value is ignored if *list\_options* is set to AP\_FIRST\_IN\_LIST.

The name is a 17-byte EBCDIC string, right-padded with EBCDIC spaces. It consists of a network ID of up to 8 A-string characters, an EBCDIC dot (period) character, and a network name of up to 8 A-string characters.

**resource\_type**

Type of resource for which information is required. This value is ignored if *list\_options* is set to AP\_FIRST\_IN\_LIST. Possible values are:

**AP\_ENCP\_RESOURCE**

End node or LEN node

**AP\_NNCP\_RESOURCE**

Network node

**AP\_LU\_RESOURCE**

LU

**parent\_name**

Fully qualified resource name of the parent resource; for an LU the parent resource is the owning Control Point, and for an end node or LEN node it is the network node server. To return only entries belonging to the specified parent, set this parameter to the name of the parent resource and *parent\_type* to the parent's resource type; to return all entries, set both parameters to binary zeros.

The name is a 17-byte EBCDIC string, padded on the right with EBCDIC spaces. It consists of a network ID of 1-8 A-string characters, an EBCDIC dot (period) character, and a network name of 1-8 A-string characters.

**parent\_type**

Resource type of the parent resource. To return only entries belonging to the specified parent, set this parameter to the type of the parent resource; to return all entries, set this parameter to zero. Possible values are:

**AP\_ENCP\_RESOURCE**

End node (for an LU resource owned by an end node)

**AP\_NNCP\_RESOURCE**

Network node (for an LU resource owned by a network node, or for an EN or LEN resource)

**Returned parameters: successful execution**

If the verb executes successfully, CS/AIX returns the following parameters:

**primary\_rc**

AP\_OK

**buf\_size**

Length of the information returned in the supplied buffer.

**total\_buf\_size**

Returned value indicating the size of buffer that would have been required to return all the list information requested. A value greater than *buf\_size* indicates that not all the available entries were returned.

**num\_entries**

Number of entries returned in the data buffer.

### ***total\_num\_entries***

Total number of entries available. A value greater than *num\_entries* indicates that not all the available entries were returned.

Each entry in the data buffer consists of the following parameters:

### ***directory\_entry\_summary.overlay\_size***

The size of the returned *directory\_entry\_summary* structure, and therefore the offset to the start of the next entry in the data buffer.

When your application needs to go through the returned buffer to find each *directory\_entry\_summary* structure in turn, it must use this value to move to the correct offset for the next data structure, and must not use the C `sizeof()` operator. This is because the size of the returned overlay may increase in future releases of CS/AIX; using the returned overlay size ensures that your application will continue to work with future releases.

### ***directory\_entry\_summary.resource\_name***

Fully qualified name of the resource. The name is a 17-byte EBCDIC string, padded on the right with EBCDIC spaces. It consists of a network ID of 1-8 A-string characters, an EBCDIC dot (period) character, and a network name of 1-8 A-string characters

### ***directory\_entry\_summary.resource\_type***

Type of the resource. This is one of the following:

#### **AP\_ENCP\_RESOURCE**

End node or LEN node

#### **AP\_NNCP\_RESOURCE**

Network node

#### **AP\_LU\_RESOURCE**

LU

### ***directory\_entry\_summary.description***

A null-terminated text string describing the directory entry, as specified in the definition of the directory entry.

### ***directory\_entry\_summary.real\_owning\_cp\_type***

This parameter applies only if the local node is a Network Node or a Branch Network Node; it is reserved otherwise.

Specifies whether the real CP that owns the resource identified by this directory entry is the parent resource or another node. This is one of the following:

#### **AP\_NONE**

The real owner is the parent resource.

#### **AP\_ENCP\_RESOURCE**

The real owner is an end node that is not the parent resource. For example, if the resource is owned by an End Node in the domain of a Branch Network Node (BrNN), the directory of this BrNN's Network Node Server includes the BrNN as the parent resource, but the real owning CP is the End Node.

### ***directory\_entry\_summary.real\_owning\_cp\_name***

This parameter applies only if the local node is a Network Node or a Branch Network Node; it is reserved otherwise.

If the *real\_owning\_cp\_type* parameter indicates that the real owner of the resource is not the parent, this parameter specifies the fully qualified name of the CP that owns the resource; otherwise it is reserved.

The name is a 17-byte EBCDIC string, padded on the right with EBCDIC spaces. It consists of a network ID of 1-8 A-string characters, an EBCDIC dot (period) character, and a network name of 1-8 A-string characters.



***directory\_entry\_detail.overlay\_size***

The size of the returned `directory_entry_detail` structure, and therefore the offset to the start of the next entry in the data buffer.

When your application needs to go through the returned buffer to find each `directory_entry_detail` structure in turn, it must use this value to move to the correct offset for the next data structure, and must not use the C `sizeof()` operator. This is because the size of the returned overlay may increase in future releases of CS/AIX; using the returned overlay size ensures that your application will continue to work with future releases.

***directory\_entry\_detail.resource\_name***

Fully qualified name of the resource. The name is a 17-byte EBCDIC string, padded on the right with EBCDIC spaces. It consists of a network ID of 1-8 A-string characters, an EBCDIC dot (period) character, and a network name of 1-8 A-string characters.

***directory\_entry\_detail.resource\_type***

Type of the resource. This is one of the following:

**AP\_ENCP\_RESOURCE**

End node or LEN node

**AP\_NNCP\_RESOURCE**

Network node

**AP\_LU\_RESOURCE**

LU

***directory\_entry\_detail.description***

A null-terminated text string describing the directory entry, as specified in the definition of the directory entry.

***directory\_entry\_detail.parent\_name***

Fully qualified resource name of the parent resource; for an LU the parent resource is the owning Control Point, and for an end node or LEN node it is the network node server. This parameter is not used for a network node resource.

The name is a 17-byte EBCDIC string, padded on the right with EBCDIC spaces. It consists of a network ID of 1-8 A-string characters, an EBCDIC dot (period) character, and a network name of 1-8 A-string characters.

***directory\_entry\_detail.parent\_type***

Resource type of the parent resource. For a network node resource, this parameter is not used. Otherwise, it is one of the following:

**AP\_ENCP\_RESOURCE**

End node (for an LU resource owned by an end node)

**AP\_NNCP\_RESOURCE**

Network node (for an LU resource owned by a network node, or for an EN or LEN resource)

***directory\_entry\_detail.entry\_type***

Specifies the type of the directory entry. This is one of the following:

**AP\_HOME**

Local resource.

**AP\_CACHE**

Cached entry.

**AP\_REGISTER**

Registered resource (NN only).

***directory\_entry\_detail.location***

Specifies the location of the resource. This is one of the following.

**AP\_LOCAL**

The resource is at the local node.

### **AP\_DOMAIN**

The resource belongs to an attached end node.

### **AP\_CROSS\_DOMAIN**

The resource is not within the domain of the local node.

### ***directory\_entry\_detail.real\_owning\_cp\_type***

This parameter applies only if the local node is a Network Node or a Branch Network Node; it is reserved otherwise.

Specifies whether the real CP that owns the resource identified by this directory entry is the parent resource or another node. This is one of the following:

### **AP\_NONE**

The real owner is the parent resource.

### **AP\_ENCP\_RESOURCE**

The real owner is an end node that is not the parent resource. For example, if the resource is owned by an End Node in the domain of a Branch Network Node (BrNN), the directory of this BrNN's Network Node Server includes the BrNN as the parent resource, but the real owning CP is the End Node.

### ***directory\_entry\_detail.real\_owning\_cp\_name***

This parameter applies only if the local node is a Network Node or a Branch Network Node; it is reserved otherwise.

If the *real\_owning\_cp\_type* parameter indicates that the real owner of the resource is not the parent, this parameter specifies the fully qualified name of the CP that owns the resource; otherwise it is reserved.

The name is a 17-byte EBCDIC string, padded on the right with EBCDIC spaces. It consists of a network ID of 1-8 A-string characters, an EBCDIC dot (period) character, and a network name of 1-8 A-string characters.

### ***directory\_entry\_detail.supplier\_cp\_type***

This parameter applies only if the local node is a Network Node or a Branch Network Node; it is reserved otherwise.

Specifies whether this directory entry was registered by another node that is not the owning CP of the resource. This is one of the following:

### **AP\_NONE**

The directory entry was not registered, or was registered by its owning CP.

### **AP\_ENCP\_RESOURCE**

The directory entry was registered by a node that is not its owning CP. For example, if the resource is owned by an End Node in the domain of a Branch Network Node (BrNN) that is itself in the domain of the local node, the BrNN is the supplier because it registers the resource with the local node, but the real owning CP is the End Node.

### ***directory\_entry\_detail.supplier\_cp\_name***

This parameter applies only if the local node is a Network Node or a Branch Network Node; it is reserved otherwise.

If the *supplier\_cp\_type* parameter indicates that the directory entry was registered by a node that is not the owning resource, this parameter specifies the fully qualified name of the CP that supplied the registration; otherwise it is reserved.

The name is a 17-byte EBCDIC string, padded on the right with EBCDIC spaces. It consists of a network ID of 1-8 A-string characters, an EBCDIC dot (period) character, and a network name of 1-8 A-string characters.

## **Returned parameters: parameter check**

If the verb does not execute because of a parameter error, CS/AIX returns the following parameters:

**primary\_rc**

AP\_PARAMETER\_CHECK

**secondary\_rc**

Possible values are:

**AP\_INVALID\_RES\_NAME**

The *list\_options* parameter was set to AP\_LIST\_INCLUSIVE, to list all entries starting from the supplied name, but the *resource\_name* parameter was not valid.

**AP\_INVALID\_RES\_TYPE**

The *resource\_type* parameter was not set to a valid value.

**AP\_INVALID\_LIST\_OPTION**

The *list\_options* parameter was not set to a valid value.

Appendix B, “Common return codes,” on page 661 lists further secondary return codes associated with AP\_PARAMETER\_CHECK, which are common to all NOF verbs.

**Returned parameters: other conditions**

Appendix B, “Common return codes,” on page 661 lists further combinations of primary and secondary return codes that are common to all NOF verbs.

**QUERY\_DIRECTORY\_LU**

QUERY\_DIRECTORY\_LU returns a list of LUs from the directory database. It can be used to obtain information about a specific LU, or about multiple LUs, depending on the options used.

This verb must be issued to a running node.

**VCB structure**

```
typedef struct query_directory_lu
{
    AP_UINT16      opcode;           /* verb operation code          */
    unsigned char  reserv2;         /* reserved                      */
    unsigned char  format;         /* reserved                      */
    AP_UINT16      primary_rc;     /* primary return code          */
    AP_UINT32      secondary_rc;   /* secondary return code        */
    unsigned char  *buf_ptr;       /* pointer to buffer            */
    AP_UINT32      buf_size;       /* buffer size                  */
    AP_UINT32      total_buf_size; /* total buffer size required   */
    AP_UINT16      num_entries;    /* number of entries            */
    AP_UINT16      total_num_entries; /* total number of entries     */
    unsigned char  list_options;   /* listing options              */
    unsigned char  reserv3;       /* reserved                      */
    unsigned char  lu_name[17];    /* network qualified lu name    */
} QUERY_DIRECTORY_LU;
```

```
typedef struct directory_lu_summary
{
    AP_UINT16      overlay_size;    /* size of returned entry       */
    unsigned char  lu_name[17];    /* network qualified lu name    */
    unsigned char  description[32]; /* resource description         */
    unsigned char  reserv1[16];    /* reserved                      */
} DIRECTORY_LU_SUMMARY;
```

```
typedef struct directory_lu_detail
{
    AP_UINT16      overlay_size;    /* size of returned entry       */
    unsigned char  lu_name[17];    /* network qualified lu name    */
    unsigned char  description[32]; /* resource description         */
    unsigned char  reserv1[16];    /* reserved                      */
    unsigned char  server_name[17]; /* network qualified server name */
    unsigned char  lu_owner_name[17]; /* network qualified lu owner name */
    unsigned char  location;       /* Resource location            */
    unsigned char  entry_type;     /* Type of the directory entry   */
    unsigned char  wild_card;     /* type of wildcard entry       */
    unsigned char  apparent_lu_owner_name[17]; /* name of apparent LU owner */
}
```

```

    unsigned char   reserva[3];           /* reserved           */
} DIRECTORY_LU_DETAIL;

```

## Supplied parameters

The application supplies the following parameters:

### ***opcode***

AP\_QUERY\_DIRECTORY\_LU

### ***buf\_ptr***

A pointer to a data buffer that CS/AIX will use to return the requested information.

### ***buf\_size***

Size of the supplied data buffer.

### ***num\_entries***

Maximum number of LUs for which data should be returned. To request data for a specific LU rather than a range, specify the value 1. To return as many entries as possible, specify zero; in this case, CS/AIX will return the maximum number of entries that can be accommodated in the supplied data buffer.

### ***list\_options***

The position in the list from which CS/AIX should begin to return data, and the level of information required for each entry. Specify the level of information with one of the following values:

#### **AP\_SUMMARY**

Summary information only.

#### **AP\_DETAIL**

Detailed information.

Combine this value using a logical OR operation with one of the following values:

#### **AP\_FIRST\_IN\_LIST**

Start at the first entry in the list.

#### **AP\_LIST\_INCLUSIVE**

Start at the entry specified by the *lu\_name* parameter.

#### **AP\_LIST\_FROM\_NEXT**

Start at the entry immediately following the entry specified by the *lu\_name* parameter.

For more information about how the list is ordered and how the application can obtain specific entries from it, see [“List options for QUERY\\_\\* Verbs” on page 33](#).

### ***lu\_name***

Fully qualified name of the LU for which information is required, or the name to be used as an index into the list of LUs. This value is ignored if *list\_options* is set to AP\_FIRST\_IN\_LIST.

The name is a 17-byte EBCDIC string, right-padded with EBCDIC spaces. It consists of a network ID of up to 8 A-string characters, an EBCDIC dot (period) character, and a network name of up to 8 A-string characters.

## Returned parameters: successful execution

If the verb executes successfully, CS/AIX returns the following parameters:

### ***primary\_rc***

AP\_OK

### ***buf\_size***

Length of the information returned in the supplied buffer.

### ***total\_buf\_size***

Returned value indicating the size of buffer that would have been required to return all the list information requested. A value greater than *buf\_size* indicates that not all the available entries were returned.

***num\_entries***

Number of entries returned in the data buffer.

***total\_num\_entries***

Total number of entries available. A value greater than *num\_entries* indicates that not all the available entries were returned.

Each entry in the data buffer consists of the following parameters:

***directory\_lu\_summary.overlay\_size***

The size of the returned *directory\_lu\_summary* structure, and therefore the offset to the start of the next entry in the data buffer.

When your application needs to go through the returned buffer to find each *directory\_lu\_summary* structure in turn, it must use this value to move to the correct offset for the next data structure, and must not use the C `sizeof()` operator. This is because the size of the returned overlay may increase in future releases of CS/AIX; using the returned overlay size ensures that your application will continue to work with future releases.

***directory\_lu\_summary.lu\_name***

Fully qualified name of the LU. The name is a 17-byte EBCDIC string, padded on the right with EBCDIC spaces. It consists of a network ID of 1-8 A-string characters, an EBCDIC dot (period) character, and a network name of 1-8 A-string characters.

***directory\_lu\_summary.description***

A null-terminated text string describing the directory entry, as specified in the definition of the directory entry.

***directory\_lu\_detail.overlay\_size***

The size of the returned *directory\_lu\_detail* structure, and therefore the offset to the start of the next entry in the data buffer.

When your application needs to go through the returned buffer to find each *directory\_lu\_detail* structure in turn, it must use this value to move to the correct offset for the next data structure, and must not use the C `sizeof()` operator. This is because the size of the returned overlay may increase in future releases of CS/AIX; using the returned overlay size ensures that your application will continue to work with future releases.

***directory\_lu\_detail.lu\_name***

Fully qualified name of the LU. The name is a 17-byte EBCDIC string, padded on the right with EBCDIC spaces. It consists of a network ID of 1-8 A-string characters, an EBCDIC dot (period) character, and a network name of 1-8 A-string characters.

***directory\_lu\_detail.description***

A null-terminated text string describing the directory entry, as specified in the definition of the directory entry.

***directory\_lu\_detail.server\_name***

Fully qualified name of the node that serves the LU. The name is a 17-byte EBCDIC string, padded on the right with EBCDIC spaces. It consists of a network ID of 1-8 A-string characters, an EBCDIC dot (period) character, and a network name of 1-8 A-string characters.

***directory\_lu\_detail.lu\_owner\_name***

Fully qualified name of the node that owns the LU. The name is a 17-byte EBCDIC string, padded on the right with EBCDIC spaces. It consists of a network ID of 1-8 A-string characters, an EBCDIC dot (period) character, and a network name of 1-8 A-string characters.

***directory\_lu\_detail.location***

Specifies the location of the resource. This is one of the following.

**AP\_LOCAL**

The resource is at the local node.

**AP\_DOMAIN**

The resource belongs to an attached end node.

**AP\_CROSS\_DOMAIN**

The resource is not within the domain of the local node.

***directory\_lu\_detail.entry\_type***

Specifies the type of the resource. This is one of the following:

**AP\_HOME**

Local resource.

**AP\_CACHE**

Cached entry.

**AP\_REGISTER**

Registered resource (NN only).

***directory\_lu\_detail.wild\_card***

Specifies whether the LU entry is for an explicit name, or for a wildcard value that will match a range of names. This is one of the following:

**AP\_EXPLICIT**

The entry is an explicit LU name.

**AP\_FULL\_WILDCARD**

The entry is a full wildcard value that will match any LU name.

**AP\_PARTIAL\_WILDCARD**

The entry is a partial wildcard; the nonblank characters in the name will be used to match against an LU name.

**AP\_OTHER**

Unknown type of LU entry.

***directory\_lu\_detail.apparent\_lu\_owner\_name***

This parameter applies only if the local node is a Network Node or a Branch Network Node; it is reserved otherwise.

If the apparent owning CP of this LU is not the real owning CP, this parameter specifies the fully qualified name of the apparent owning CP; otherwise it is reserved. For example, if the resource is owned by an End Node in the domain of a Branch Network Node (BrNN), the directory of this BrNN's Network Node Server includes the BrNN as the apparent owner, but the real owning CP is the End Node.

The name is a 17-byte EBCDIC string, padded on the right with EBCDIC spaces. It consists of a network ID of 1-8 A-string characters, an EBCDIC dot (period) character, and a network name of 1-8 A-string characters.

## Returned parameters: parameter check

If the verb does not execute because of a parameter error, CS/AIX returns the following parameters:

***primary\_rc***

AP\_PARAMETER\_CHECK

***secondary\_rc***

Possible values are:

**AP\_INVALID\_LU\_NAME**

The *list\_options* parameter was set to AP\_LIST\_INCLUSIVE, to list all entries starting from the supplied name, but the *lu\_name* parameter was not valid.

**AP\_INVALID\_LIST\_OPTION**

The *list\_options* parameter was not set to a valid value.

Appendix B, "Common return codes," on page 661 lists further secondary return codes associated with AP\_PARAMETER\_CHECK, which are common to all NOF verbs.

## Returned parameters: other conditions

Appendix B, “Common return codes,” on page 661 lists further combinations of primary and secondary return codes that are common to all NOF verbs.

## QUERY\_DIRECTORY\_STATS

QUERY\_DIRECTORY\_STATS returns directory database statistics, which can be used to gauge the level of network locate traffic. For a network node, it returns information about the usage of the directory cache; you can use this information to determine the appropriate cache size, which is specified on the DEFINE\_NODE verb.

This verb must be issued to a running node.

## VCB structure

```
typedef struct query_directory_stats
{
    AP_UINT16      opcode;                /* verb operation code      */
    unsigned char  reserv2;              /* reserved                  */
    unsigned char  format;               /* reserved                  */
    AP_UINT16      primary_rc;           /* primary return code      */
    AP_UINT32      secondary_rc;         /* secondary return code    */
    AP_UINT32      max_caches;           /* maximum number of cache  */
                                           /* entries                   */
    AP_UINT32      cur_caches;           /* cache entry count        */
    AP_UINT32      cur_home_entries;     /* home entry count         */
    AP_UINT32      cur_reg_entries;      /* registered entry count   */
    AP_UINT32      cur_directory_entries; /* current number of directory */
                                           /* entries                   */
    AP_UINT32      cache_hits;           /* count of cache finds     */
    AP_UINT32      cache_misses;         /* count of resources found */
                                           /* by broadcast search      */
                                           /* (not in cache)          */
    AP_UINT32      in_locates;           /* locates in               */
    AP_UINT32      in_bcast_locates;     /* broadcast locates in     */
    AP_UINT32      out_locates;          /* locates out              */
    AP_UINT32      out_bcast_locates;    /* broadcast locates out    */
    AP_UINT32      not_found_locates;    /* unsuccessful locates     */
    AP_UINT32      not_found_bcast_locates; /* unsuccessful broadcast  */
                                           /* locates                  */
    AP_UINT32      locates_outstanding;  /* total outstanding locates */
    unsigned char  reserva[20];         /* reserved                  */
} QUERY_DIRECTORY_STATS;
```

## Supplied parameters

The application supplies the following parameter:

### *opcode*

AP\_QUERY\_DIRECTORY\_STATS

## Returned parameters: successful execution

If the verb executes successfully, CS/AIX returns the following parameters:

### *primary\_rc*

AP\_OK

### *max\_caches*

For a network node, the maximum number of cache entries allowed.

### *cur\_caches*

For a network node, the current number of cache entries.

### *cur\_home\_entries*

Current number of home entries.

## QUERY\_DLC

### ***cur\_reg\_entries***

Current number of registered entries.

### ***cur\_directory\_entries***

Total number of entries currently in the directory.

### ***cache\_hits***

For a network node, the number of successful cache finds. The count is increased every time a resource is found in the local directory cache.

### ***cache\_misses***

For a network node, the number of times a resource has been found by a broadcast search. The count is increased every time a resource is not found in the local directory cache but is then found using a broadcast search.

**Note:** The two counts *cache\_hits* and *cache\_misses* are maintained such that the size of the directory cache (specified on *DEFINE\_NODE*) can be tuned. An increasing *cache\_misses* over time indicates that the directory cache size is too small. A regularly increasing *cache\_hits* with a steady *cache\_misses* indicates that the cache is about the right size.

### ***in\_locates***

Number of directed locates received.

### ***in\_bcast\_locates***

For a network node, the number of broadcast locates received.

### ***out\_locates***

Number of directed locates sent.

### ***out\_bcast\_locates***

For a network node, the number of broadcast locates sent.

### ***not\_found\_locates***

Number of directed locates returned "not found".

### ***not\_found\_bcast\_locates***

For a network node, the number of broadcast locates returned "not found".

### ***locates\_outstanding***

Current number of outstanding locates, both directed and broadcast.

## Returned parameters: other conditions

Appendix B, "Common return codes," on page 661 lists further combinations of primary and secondary return codes that are common to all NOF verbs.

## QUERY\_DLC

---

QUERY\_DLC returns information about DLCs. This information is structured as "determined data" (data gathered dynamically during execution) and "defined data" (data supplied on *DEFINE\_DLC*).

This verb can be used to obtain either summary or detailed information, about a specific DLC or about multiple DLCs, depending on the options used.

## VCB structure

```
typedef struct query_dlc
{
    AP_UINT16      opcode;                /* verb operation code          */
    unsigned char  reserv2;               /* reserved                     */
    unsigned char  format;                /* reserved                     */
    AP_UINT16      primary_rc;            /* primary return code          */
    AP_UINT32      secondary_rc;          /* secondary return code        */
    unsigned char  *buf_ptr;              /* pointer to buffer            */
    AP_UINT32      buf_size;              /* buffer size                  */
    AP_UINT32      total_buf_size;        /* total buffer size required   */
    AP_UINT16      num_entries;           /* number of entries            */
    AP_UINT16      total_num_entries;     /* total number of entries      */
}
```



```

    unsigned char list_options;      /* listing options      */
    unsigned char reserv3;          /* reserved             */
    unsigned char dlc_name[8];     /* name of DLC         */
} QUERY_DLC;

```

```

typedef struct dlc_summary
{
    AP_UINT16 overlay_size;        /* size of returned entry */
    unsigned char dlc_name[8];    /* name of DLC           */
    unsigned char description[32]; /* resource description  */
    unsigned char reserv1[16];    /* reserved              */
    unsigned char state;         /* State of the DLC     */
    unsigned char dlc_type;      /* DLC type             */
} DLC_SUMMARY;

```

```

typedef struct dlc_detail
{
    AP_UINT16 overlay_size;        /* size of returned entry */
    unsigned char dlc_name[8];    /* name of DLC           */
    unsigned char reserv2[2];     /* reserved              */
    DLC_DET_DATA det_data;       /* Determined data      */
    DLC_DEF_DATA def_data;       /* Defined data         */
} DLC_DETAIL;

```

```

typedef struct dlc_det_data
{
    unsigned char state;          /* State of the DLC     */
    unsigned char reserv3[3];    /* reserved             */
    unsigned char reserva[20];   /* reserved             */
} DLC_DET_DATA;

```

```

typedef struct dlc_def_data
{
    unsigned char description[32]; /* resource description */
    unsigned char initially_active; /* is DLC initially active? */
    unsigned char reserv1[15];    /* reserved             */
    unsigned char dlc_type;      /* DLC type            */
    unsigned char neg_ls_supp;    /* negotiable link station support */
    unsigned char port_types;    /* port types supported by DLC type */
    unsigned char hpr_only;      /* only support HPR?  */
    unsigned char reserv3;       /* reserved             */
    unsigned char retry_flags;   /* reserved             */
    AP_UINT16 max_activation_attempts; /* reserved          */
    AP_UINT16 activation_delay_timer; /* reserved          */
    unsigned char reserv4[4];    /* reserved             */
    AP_UINT16 dlc_spec_data_len; /* Length of DLC specific data */
} DLC_DEF_DATA;

```

For more details of the DLC-specific data, see “[DEFINE\\_DLC](#)” on page 74. The data structure for this data follows the `dlc_def_data` structure, but is padded to start on a 4-byte boundary.

## Supplied parameters

The application supplies the following parameters:

### ***opcode***

AP\_QUERY\_DLC

### ***buf\_ptr***

A pointer to a data buffer that CS/AIX will use to return the requested information.

### ***buf\_size***

Size of the supplied data buffer.

### ***num\_entries***

Maximum number of DLCs for which data should be returned. To request data for a specific DLC rather than a range, specify the value 1. To return as many entries as possible, specify zero; in this case, CS/AIX will return the maximum number of entries that can be accommodated in the supplied data buffer.

***list\_options***

The position in the list from which CS/AIX should begin to return data, and the level of information required for each entry. Specify the level of information with one of the following values:

**AP\_SUMMARY**

Summary information only.

**AP\_DETAIL**

Detailed information.

Combine this value using a logical OR operation with one of the following values:

**AP\_FIRST\_IN\_LIST**

Start at the first entry in the list.

**AP\_LIST\_INCLUSIVE**

Start at the entry specified by the *dlc\_name* parameter.

**AP\_LIST\_FROM\_NEXT**

Start at the entry immediately following the entry specified by the *dlc\_name* parameter.

For more information about how the list is ordered and how the application can obtain specific entries from it, see [“List options for QUERY\\_\\* Verbs”](#) on page 33.

***dlc\_name***

DLC name for which information is required, or the name to be used as an index into the list of DLCs. This parameter is ignored if *list\_options* is set to AP\_FIRST\_IN\_LIST. The name is an 8-byte ASCII string, padded on the right with spaces if the name is shorter than 8 characters.

## Returned parameters: successful execution

If the verb executes successfully, CS/AIX returns the following parameters:

***primary\_rc***

AP\_OK

***buf\_size***

Length of the information returned in the supplied buffer.

***total\_buf\_size***

Returned value indicating the size of buffer that would have been required to return all the list information requested. A value greater than *buf\_size* indicates that not all the available entries were returned.

***num\_entries***

Number of entries returned in the data buffer.

***total\_num\_entries***

Total number of entries available. A value greater than *num\_entries* indicates that not all the available entries were returned.

Each entry in the data buffer consists of the following parameters:

***dlc\_summary.overlay\_size***

The size of the returned *dlc\_summary* structure, and therefore the offset to the start of the next entry in the data buffer.

When your application needs to go through the returned buffer to find each *dlc\_summary* structure in turn, it must use this value to move to the correct offset for the next data structure, and must not use the C `sizeof()` operator. This is because the size of the returned overlay may increase in future releases of CS/AIX; using the returned overlay size ensures that your application will continue to work with future releases.

***dlc\_summary.dlc\_name***

DLC name. The name is an 8-byte ASCII string, padded on the right with spaces if the name is shorter than 8 characters.

***dlc\_summary.description***

A null-terminated text string describing the DLC, as specified in the definition of the DLC.

***dlc\_summary.state***

State of the DLC. This is one of the following:

**AP\_ACTIVE**

The DLC is active.

**AP\_NOT\_ACTIVE**

The DLC is not active.

**AP\_PENDING\_INACTIVE**

STOP\_DLC is in progress.

***dlc\_summary.dlc\_type***

Type of DLC. This is one of the following:

**AP\_SDLC**

SDLC

**AP\_X25**

QLLC

**AP\_TR**

Token Ring

**AP\_ETHERNET**

Ethernet

**AP\_IP**

Enterprise Extender (HPR/IP)

***dlc\_detail.overlay\_size***

The size of the returned `dlc_detail` structure, and therefore the offset to the start of the next entry in the data buffer.

When your application needs to go through the returned buffer to find each `dlc_detail` structure in turn, it must use this value to move to the correct offset for the next data structure, and must not use the C `sizeof()` operator. This is because the size of the returned overlay may increase in future releases of CS/AIX; using the returned overlay size ensures that your application will continue to work with future releases.

***dlc\_detail.dlc\_name***

DLC name. The name is an 8-byte ASCII string, padded on the right with spaces if the name is shorter than 8 characters.

***dlc\_detail.det\_data.state***

State of the DLC. This is one of the following:

**AP\_ACTIVE**

The DLC is active.

**AP\_NOT\_ACTIVE**

The DLC is not active.

**AP\_PENDING\_INACTIVE**

STOP\_DLC is in progress.

***dlc\_detail.def\_data.description***

A null-terminated text string describing the DLC, as specified in the definition of the DLC.

***dlc\_detail.def\_data.initially\_active***

Specifies whether this DLC is automatically started when the node is started. Possible values are:

**AP\_YES**

The DLC is automatically started when the node is started.

**AP\_NO**

The DLC is not automatically started; it must be started manually.

***dlc\_detail.def\_data.dlc\_type***

Type of DLC. This is one of the following:

**AP\_SDLC**

SDLC

**AP\_X25**

QLLC

**AP\_TR**

Token Ring

**AP\_ETHERNET**

Ethernet

**AP\_IP**

Enterprise Extender (HPR/IP)

***dlc\_detail.def\_data.neg\_ls\_supp***

Specifies whether the DLC supports negotiable link stations. Possible values are:

**AP\_YES**

Link stations using this DLC may be negotiable.

**AP\_NO**

Link stations using this DLC must be defined as either primary or secondary; negotiable link stations are not supported.

***dlc\_detail.def\_data.port\_types***

If *dlc\_type* is set to AP\_TR / AP\_ETHERNET / AP\_IP, this parameter will be set to AP\_PORT\_SATF. For other DLC types, this parameter is reserved.

***dlc\_detail.def\_data.hpr\_only***

Specifies whether the DLC is used for Enterprise Extender links and therefore supports only HPR traffic. Possible values are:

**AP\_YES**

This DLC is used for Enterprise Extender links, and supports only HPR traffic.

**AP\_NO**

This DLC is not used for Enterprise Extender links, and supports non-HPR traffic; it may also support HPR traffic.

***dlc\_detail.def\_data.dlc\_spec\_data\_len***

Unpadded length, in bytes, of data specific to the type of DLC. The data structure for this data follows the *def\_data* structure, but is padded to start on a 4-byte boundary. For more details of the DLC-specific data, see [“DEFINE\\_DLC”](#) on page 74.

## Returned parameters: parameter check

If the verb does not execute because of a parameter error, CS/AIX returns the following parameters:

***primary\_rc***

AP\_PARAMETER\_CHECK

***secondary\_rc***

Possible values are:

**AP\_INVALID\_DLC\_NAME**

The *list\_options* parameter was set to AP\_LIST\_INCLUSIVE, to list all entries starting from the supplied name, but the *dlc\_name* parameter was not valid.

**AP\_INVALID\_LIST\_OPTION**

The *list\_options* parameter was not set to a valid value.

Appendix B, [“Common return codes,”](#) on page 661 lists further secondary return codes associated with AP\_PARAMETER\_CHECK, which are common to all NOF verbs.

## Returned parameters: other conditions

Appendix B, “Common return codes,” on page 661 lists further combinations of primary and secondary return codes that are common to all NOF verbs.

## QUERY\_DLC\_TRACE

QUERY\_DLC\_TRACE returns information about DLC line tracing, which was set up using ADD\_DLC\_TRACE verbs.

This verb can be used to obtain information about tracing on all resources, on a specific resource type, or on a specific resource, depending on the options used.

## VCB structure

```
typedef struct query_dlc_trace
{
    AP_UINT16          opcode;          /* Verb operation code          */
    unsigned char     reserv2;         /* reserved                     */
    unsigned char     format;         /* reserved                     */
    AP_UINT16         primary_rc;     /* Primary return code         */
    AP_UINT32         secondary_rc;   /* Secondary return code       */
    unsigned char     *buf_ptr;       /* pointer to buffer           */
    AP_UINT32         buf_size;       /* buffer size                 */
    AP_UINT32         total_buf_size; /* total buffer size required  */
    AP_UINT16         num_entries;    /* number of entries           */
    AP_UINT16         total_num_entries; /* total number of entries    */
    unsigned char     list_options;   /* listing options             */
    unsigned char     list_type;      /* type of listing required    */
    DLC_TRACE_FILTER filter_entry;    /* resource to start at       */
} QUERY_DLC_TRACE;
```

```
typedef struct dlc_trace_data
{
    AP_UINT16          overlay_size;   /* size of returned entry      */
    DLC_TRACE_FILTER  filter;         /* DLC trace filter information */
} DLC_TRACE_DATA;
```

```
typedef struct dlc_trace_filter
{
    unsigned char     resource_type;   /* type of resource           */
    unsigned char     resource_name[8]; /* name of resource           */
    SNA_LFSID         lfsid;          /* session identifier         */
    unsigned char     message_type;   /* type of messages          */
} DLC_TRACE_FILTER;
```

```
typedef struct sna_lfsid
{
    union
    {
        AP_UINT16          session_id;
        struct
        {
            unsigned char  sidh;
            unsigned char  sidl;
        } s;
    } uu;
    AP_UINT16            odai;
} SNA_LFSID;
```

## Supplied parameters

The application supplies the following parameters:

### *opcode*

AP\_QUERY\_DLC\_TRACE

### *buf\_ptr*

A pointer to a data buffer that CS/AIX will use to return the requested information.

***buf\_size***

Size of the supplied data buffer.

***num\_entries***

Maximum number of DLC\_TRACE entries for which data should be returned. To request data for a specific entry rather than a range, specify the value 1. To return as many entries as possible, specify zero; in this case, CS/AIX will return the maximum number of entries that can be accommodated in the supplied data buffer.

***list\_options***

The position in the list of DLC\_TRACE entries from which CS/AIX should begin to return data. Possible values are:

**AP\_FIRST\_IN\_LIST**

Start at the first entry in the list.

**AP\_LIST\_INCLUSIVE**

Start at the entry specified by the *filter\_entry* structure.

**AP\_LIST\_FROM\_NEXT**

Start at the entry immediately following the entry specified by the *filter\_entry* structure.

For more information about how the list is ordered and how the application can obtain specific entries from it, see [“List options for QUERY\\_\\* Verbs” on page 33](#).

***list\_type***

The type of resource for which to list tracing options. Possible values are:

**AP\_ALL\_DLC\_TRACES**

List all specified tracing options (for any resource type).

**AP\_ALL\_RESOURCES**

List the tracing options specified for all resources (defined using ADD\_DLC\_TRACE with a resource type of AP\_ALL\_RESOURCES).

**AP\_DLC**

List tracing options for DLC resources.

**AP\_PORT**

List tracing options for port resources for which all LSs are traced.

**AP\_LS**

List tracing options for LS resources.

**AP\_RTP\_RESOURCE\_TYPE**

List tracing options for RTP connection resources.

**AP\_PORT\_DEFINED\_LS**

List tracing options for port resources for which only defined LSs (not implicit LSs) are traced.

**AP\_PORT\_IMPLICIT\_LS**

List tracing options for port resources for which only implicit LSs (not defined LSs) are traced.

***filter\_entry.resource\_type***

Specifies the resource type of the entry to be returned, or the entry to be used as an index into the list. This parameter is used only if *list\_type* is set to AP\_ALL\_DLC\_TRACES and *list\_options* is not set to AP\_FIRST\_IN\_LIST. Possible values are:

**AP\_ALL\_RESOURCES**

The required entry specifies the options used for tracing all DLCs, ports, and LSs.

**AP\_DLC**

The required entry specifies tracing options for the DLC named in *resource\_name*, and for all ports and LSs that use this DLC.

**AP\_PORT**

The required entry specifies tracing options for the port named in *resource\_name*, and for all LSs that use this port.

**AP\_LS**

The required entry specifies tracing options for the LS named in *resource\_name*.

**AP\_RTP\_RESOURCE\_TYPE**

The required entry specifies tracing options for the RTP connection named in the *resource\_name* parameter.

**AP\_PORT\_DEFINED\_LS**

The required entry specifies tracing options for the port named in *resource\_name*, and for all defined LSs (but not implicit LSs) that use this port.

**AP\_PORT\_IMPLICIT\_LS**

The required entry specifies tracing options for the port named in *resource\_name*, and for all implicit LSs (but not defined LSs) that use this port.

***filter\_entry.resource\_name***

The name of the entry to be returned, or the entry to be used as an index into the list. This parameter is ignored if *list\_options* is set to AP\_FIRST\_IN\_LIST, or if *resource\_type* is set to AP\_ALL\_RESOURCES.

***filter\_entry.lfsid***

The Local Form Session Identifier for a session on the specified LS. This is only valid for *resource\_type* AP\_LS, and indicates that the required entry specifies messages on a particular session for the specified LS. The structure contains the following three values, which are returned in the SESSION\_STATS section of a QUERY\_SESSION verb:

***filter\_entry.lfsid.uu.s.sidh***

Session ID high byte.

***filter\_entry.lfsid.uu.s.sidl***

Session ID low byte.

***filter\_entry.lfsid.odai***

Origin Destination Assignor Indicator.

## Returned parameters: successful execution

If the verb executes successfully, CS/AIX returns the following parameters:

***primary\_rc***

AP\_OK

***buf\_size***

Length of the information returned in the supplied buffer.

***total\_buf\_size***

Returned value indicating the size of buffer that would have been required to return all the list information requested. A value greater than *buf\_size* indicates that not all the available entries were returned.

***num\_entries***

Number of entries returned in the data buffer.

***total\_num\_entries***

Total number of entries available. A value greater than *num\_entries* indicates that not all the available entries were returned.

Each entry in the data buffer contains the following parameters:

***overlay\_size***

The size of the returned *dlc\_trace\_data* structure, and therefore the offset to the start of the next entry in the data buffer.

When your application needs to go through the returned buffer to find each *dlc\_trace\_data* structure in turn, it must use this value to move to the correct offset for the next data structure, and must not use the C `sizeof()` operator. This is because the size of the returned overlay may increase in future releases of CS/AIX; using the returned overlay size ensures that your application will continue to work with future releases.

***dlc\_trace\_filter.resource\_type***

The type of resource being traced. This can take one of the following values:

**ALL\_RESOURCES**

The entry specifies tracing options for all resources.

**AP\_DLC**

The entry specifies tracing options for the DLC named in *resource\_name*, and for all ports and LSs that use this DLC.

**AP\_PORT**

The entry specifies tracing options for the port named in *resource\_name*, and for all LSs that use this port.

**AP\_LS**

The entry specifies tracing options for the LS named in *resource\_name* (or for a particular LFSID on this LS).

**AP\_RTP\_RESOURCE\_TYPE**

The entry specifies tracing options for the RTP connection named in *resource\_name*.

**AP\_PORT\_DEFINED\_LS**

The entry specifies tracing options for the port named in *resource\_name*, and for all defined LSs (but not implicit LSs) that use this port.

**AP\_PORT\_IMPLICIT\_LS**

The entry specifies tracing options for the port named in *resource\_name*, and for all implicit LSs (but not defined LSs) that use this port.

***dlc\_trace\_filter.resource\_name***

The name of the DLC, port, or LS being traced.

***dlc\_trace\_filter.lfsid***

The Local Form Session Identifier for a session on the specified LS. This is only valid for *resource\_type* AP\_LS, and indicates that only messages on this session are to be traced. The structure contains the following three values, which are returned in the SESSION\_STATS section of a QUERY\_SESSION verb:

***dlc\_trace\_filter.lfsid.uu.s.sidh***

Session ID high byte.

***dlc\_trace\_filter.lfsid.uu.s.sidl***

Session ID low byte.

***dlc\_trace\_filter.lfsid.odai***

Origin Destination Assignor Indicator.

***dlc\_trace\_filter.message\_type***

The type of messages being traced for the specified resource or session. This parameter is set to AP\_TRACE\_ALL to trace all messages, or to one or more of the following values (combined using a logical OR):

**AP\_TRACE\_XID**

XID messages

**AP\_TRACE\_SC**

Session Control RUs

**AP\_TRACE\_DFC**

Data Flow Control RUs

**AP\_TRACE\_FMD**

FMD messages

**AP\_TRACE\_NLP**

(this message type is currently not used)

**AP\_TRACE\_NC**

(this message type is currently not used)

**AP\_TRACE\_SEGS**

Non-BBIU segments that do not contain an RH



**AP\_TRACE\_CTL**

Messages other than MUs and XIDs

**Returned parameters: parameter check**

If the verb does not execute because of a parameter error, CS/AIX returns one of the following.

**primary\_rc**

AP\_PARAMETER\_CHECK

**secondary\_rc**

Possible values are:

**AP\_INVALID\_LIST\_TYPE**

The *list\_type* parameter specified a value that was not valid.

**AP\_INVALID\_RESOURCE\_TYPE**

The *resource\_type* parameter specified a value that was not valid.

**AP\_ALL\_RESOURCES\_NOT\_DEFINED**

The *resource\_type* parameter was set to AP\_ALL\_RESOURCES, but there is no DLC\_TRACE entry defined for tracing options on all resources.

**AP\_INVALID\_RTP\_CONNECTION**

The RTP connection named in the *resource\_name* parameter does not have any tracing options set.

Appendix B, “Common return codes,” on page 661 lists further secondary return codes associated with AP\_PARAMETER\_CHECK, which are common to all NOF verbs.

**Returned parameters: other conditions**

Appendix B, “Common return codes,” on page 661 lists further combinations of primary and secondary return codes that are common to all NOF verbs.

**QUERY\_DLUR\_DEFAULTS**

The QUERY\_DLUR\_DEFAULTS verb allows the user to query the defaults defined using the DEFINE\_DLUR\_DEFAULTS verb.

**VCB structure**

```
typedef struct query_dlur_defaults
{
    AP_UINT16      opcode;                /* verb operation code      */
    unsigned char  reserv2;              /* reserved                  */
    unsigned char  format;              /* reserved                  */
    AP_UINT16      primary_rc;          /* primary return code      */
    AP_UINT32      secondary_rc;        /* secondary return code    */
    unsigned char  description[32];     /* resource description     */
    unsigned char  reserv1[16];        /* reserved                  */
    unsigned char  dlus_name[17];      /* DLUS name                 */
    unsigned char  bkup_dlus_name[17]; /* Backup DLUS name        */
    unsigned char  reserv3;            /* reserved                  */
    AP_UINT16      dlus_retry_timeout; /* DLUS retry timeout      */
    AP_UINT16      dlus_retry_limit;   /* DLUS retry limit        */
    unsigned char  prefer_active_dlus; /* reserved                  */
    unsigned char  persistent_pipe_support; /* reserved                */
    unsigned char  reserv4[14];        /* reserved                  */
} QUERY_DLUR_DEFAULTS;
```

**Supplied parameters**

The application supplies the following parameters:

**opcode**

AP\_QUERY\_DLUR\_DEFAULTS

## QUERY\_DLUR\_LU

### ***description***

Resource description. The length of this parameter is a multiple of four bytes and is nonzero.

### ***dlus\_name***

Name of the DLUS node that is the default. This name is set to all zeros or a 17-byte EBCDIC string, right-padded with EBCDIC spaces. It consists of a network ID of up to 8 A-string characters, an EBCDIC dot (period) character, and a network name of up to 8 A-string characters.

### ***bkup\_dlus\_name***

Name of the DLUS node that serves as the backup default. This name is set to all zeros or a 17-byte EBCDIC string, right-padded with EBCDIC spaces. It consists of a network ID of up to 8 A-string characters, an EBCDIC dot (period) character, and a network name of up to 8 A-string characters.

### ***dlus\_retry\_timeout***

Interval in seconds between second and subsequent attempts to contact a DLUS. The interval between the initial attempt and the first retry is always one second.

### ***dlus\_retry\_limit***

Maximum number of retries after an initial failure to contact a DLUS. A value of 0xFFFF indicates that CS/AIX retries indefinitely.

## Returned parameters: successful execution

If the verb executes successfully, CS/AIX returns the following parameter:

### ***primary\_rc***

AP\_OK

## Returned parameters: function not supported

If the verb does not execute successfully because the local node configuration does not support it, CS/AIX returns the following parameter:

### ***primary\_rc***

#### **AP\_FUNCTION\_NOT\_SUPPORTED**

The local node does not support DLUR; this is defined by the *dlur\_support* parameter on the DEFINE\_NODE verb.

## Returned parameters: other conditions

Appendix B, “Common return codes,” on page 661 lists further combinations of primary and secondary return codes that are common to all NOF verbs.

## QUERY\_DLUR\_LU

---

QUERY\_DLUR\_LU returns information about active LUs that are using the DLUR feature of CS/AIX. This verb can be used to obtain information about a specific LU, or about multiple LUs, depending on the options used.

This verb must be issued to a running node.

## VCB structure

```
typedef struct query_dlur_lu
{
    AP_UINT16      opcode;           /* verb operation code          */
    unsigned char  reserv2;         /* reserved                     */
    unsigned char  format;         /* reserved                     */
    AP_UINT16      primary_rc;     /* primary return code          */
    AP_UINT32      secondary_rc;   /* secondary return code        */
    unsigned char  *buf_ptr;       /* pointer to buffer            */
    AP_UINT32      buf_size;       /* buffer size                  */
    AP_UINT32      total_buf_size; /* total buffer size required   */
    AP_UINT16      num_entries;    /* number of entries            */
    AP_UINT16      total_num_entries; /* total number of entries     */
}
```

```

    unsigned char    list_options;        /* listing options          */
    unsigned char    reserv3;            /* reserved                  */
    unsigned char    lu_name[8];        /* LU name                   */
    unsigned char    pu_name[8];        /* PU name filter           */
    unsigned char    filter;            /* local / downstream filter */
} QUERY_DLUR_LU;

```

```

typedef struct dlur_lu_summary
{
    AP_UINT16        overlay_size;       /* size of returned entry   */
    unsigned char    lu_name[8];        /* LU name                   */
} DLUR_LU_SUMMARY;

```

```

typedef struct dlur_lu_detail
{
    AP_UINT16        overlay_size;       /* size of returned entry   */
    unsigned char    lu_name[8];        /* LU name                   */
    unsigned char    pu_name[8];        /* PU name of owning PU     */
    unsigned char    dlus_name[17];     /* DLUS name if SSCP-LU session
                                        /* active                   */
    unsigned char    lu_location;       /* downstream or local LU   */
    unsigned char    nau_address;       /* NAU address of LU        */
    unsigned char    plu_name[17];     /* PLU name if PLU-SLU session
                                        /* active                   */
    unsigned char    reserv1[27];       /* reserved                  */
    unsigned char    rscv_len;         /* length of appended RSCV */
} DLUR_LU_DETAIL;

```

**Note:** The DLUR\_LU\_DETAIL structure may be followed by a Route Selection Control Vector (RSCV) as defined by SNA Formats. This control vector defines the session route through the network and is carried on the BIND. This RSCV is included only if the node's configuration (specified using DEFINE\_NODE) indicates that RSCVs should be stored for DLUR sessions and if the PLU-SLU session is active.

## Supplied parameters

The application supplies the following parameters:

### **opcode**

AP\_QUERY\_DLUR\_LU

### **buf\_ptr**

A pointer to a data buffer that CS/AIX will use to return the requested information.

### **buf\_size**

Size of the supplied data buffer.

### **num\_entries**

Maximum number of DLUR LUs for which data should be returned. To request data for a specific LU rather than a range, specify the value 1. To return as many entries as possible, specify zero; in this case, CS/AIX will return the maximum number of entries that can be accommodated in the supplied data buffer.

### **list\_options**

The position in the list from which CS/AIX should begin to return data, and the level of information required for each entry. Specify the level of information with one of the following values:

#### **AP\_SUMMARY**

Summary information only.

#### **AP\_DETAIL**

Detailed information.

Combine this value using a logical OR operation with one of the following values:

#### **AP\_FIRST\_IN\_LIST**

Start at the first entry in the list.

#### **AP\_LIST\_INCLUSIVE**

Start at the entry specified by the combination of the *pu\_name* and *lu\_name* parameters.

**AP\_LIST\_FROM\_NEXT**

Start at the entry immediately following the entry specified by the combination of the *pu\_name* and *lu\_name* parameters.

The list is ordered by *pu\_name* and then by *lu\_name*. For more information about how the application can obtain specific entries from the list, see [“List options for QUERY\\_\\* Verbs” on page 33](#).

**lu\_name**

Name of the LU for which information is required, or the name to be used as an index into the list of LUs. This value is ignored if *list\_options* is set to AP\_FIRST\_IN\_LIST. The name is an 8-byte EBCDIC type-A string, padded on the right with EBCDIC spaces if the name is shorter than 8 characters.

**pu\_name**

PU name for which LU information is required. To list only information about LUs associated with a specific PU, specify the PU name. To obtain a complete list for all PUs, set this field to binary zeros. The name is an 8-byte EBCDIC type-A string, padded on the right with EBCDIC spaces if the name is shorter than 8 characters.

**filter**

Specifies whether to filter the returned LUs according to their location. Allowed values for network node:

**AP\_INTERNAL**

Return information only for internal LUs.

**AP\_DOWNSTREAM**

Return information only for downstream LUs.

**AP\_NONE**

Return information about all LUs irrespective of location.

For end node, this parameter is reserved (downstream DLUR LUs are not supported).

**Returned parameters: successful execution**

If the verb executes successfully, CS/AIX returns the following parameters:

**primary\_rc**

AP\_OK

**buf\_size**

Length of the information returned in the supplied buffer.

**total\_buf\_size**

Returned value indicating the size of buffer that would have been required to return all the list information requested. A value greater than *buf\_size* indicates that not all the available entries were returned.

**num\_entries**

Number of entries returned in the data buffer.

**total\_num\_entries**

Total number of entries available. A value greater than *num\_entries* indicates that not all the available entries were returned.

Each entry in the data buffer consists of the following parameters:

**dlur\_lu\_summary.overlay\_size**

The size of the returned *dlur\_lu\_summary* structure, and therefore the offset to the start of the next entry in the data buffer.

When your application needs to go through the returned buffer to find each *dlur\_lu\_summary* structure in turn, it must use this value to move to the correct offset for the next data structure, and must not use the C `sizeof()` operator. This is because the size of the returned overlay may increase in future releases of CS/AIX; using the returned overlay size ensures that your application will continue to work with future releases.

***dlur\_lu\_summary.lu\_name***

Name of the LU. The name is an 8-byte EBCDIC type-A string, padded on the right with EBCDIC spaces if the name is shorter than 8 characters.

***dlur\_lu\_detail.overlay\_size***

The size of the returned `dlur_lu_detail` structure, and therefore the offset to the start of the next entry in the data buffer.

When your application needs to go through the returned buffer to find each `dlur_lu_detail` structure in turn, it must use this value to move to the correct offset for the next data structure, and must not use the C `sizeof()` operator. This is because the size of the returned overlay may increase in future releases of CS/AIX; using the returned overlay size ensures that your application will continue to work with future releases.

***dlur\_lu\_detail.lu\_name***

Name of the LU. The name is an 8-byte EBCDIC type-A string, padded on the right with EBCDIC spaces if the name is shorter than 8 characters.

***dlur\_lu\_detail.pu\_name***

Name of PU associated with the LU. This is an 8-byte type-A EBCDIC string (starting with a letter), padded on the right with EBCDIC spaces.

***dlur\_lu\_detail.dlus\_name***

If the SSCP-LU session is active, this field contains the name of the DLUS node used by the LU; otherwise it is set to 17 binary zeros. The name is a 17-byte EBCDIC string, right-padded with EBCDIC spaces. It consists of a network ID of up to 8 A-string characters, an EBCDIC dot (period) character, and a network name of up to 8 A-string characters.

***dlur\_lu\_detail.lu\_location***

Location of LU.

This is set to one of the following.

***AP\_INTERNAL***

LU is on the local node.

***AP\_DOWNSTREAM***

LU is on a downstream node (network node only).

***dlur\_lu\_detail.nau\_address***

Network accessible unit address of the LU.

***dlur\_lu\_detail.plu\_name***

If the PLU-SLU session is active, this field contains the name of the PLU; otherwise it is set to 17 binary zeros. The name is a 17-byte EBCDIC string, right-padded with EBCDIC spaces. It consists of a network ID of up to 8 A-string characters, an EBCDIC dot (period) character, and a network name of up to 8 A-string characters.

***dlur\_lu\_detail.rscv\_len***

Length of the RSCV that is appended to the `dlur_lu_detail` structure. If the node's configuration specifies that DLUR RSCVs are not stored, or if the PLU-SLU session is not active, this length is set to zero and no RSCV is included.

## Returned parameters: parameter check

If the verb does not execute because of a parameter error, CS/AIX returns the following parameters:

***primary\_rc***

AP\_PARAMETER\_CHECK

***secondary\_rc***

Possible values are:

***AP\_INVALID\_LU\_NAME***

The *list\_options* parameter was set to `AP_LIST_INCLUSIVE` to list all entries starting from the supplied name, but the *lu\_name* parameter was not valid.

## QUERY\_DLUR\_PU

### AP\_INVALID\_FILTER\_OPTION

The *filter* parameter was not set to a valid value.

### AP\_INVALID\_LIST\_OPTION

The *list\_options* parameter was not set to a valid value.

Appendix B, “Common return codes,” on page 661 lists further secondary return codes associated with AP\_PARAMETER\_CHECK, which are common to all NOF verbs.

## Returned parameters: function not supported

If the verb does not execute successfully because the local node configuration does not support it, CS/AIX returns the following parameter:

### *primary\_rc*

#### AP\_FUNCTION\_NOT\_SUPPORTED

The local node does not support DLUR; this is defined by the *dlur\_support* parameter on the DEFINE\_NODE verb.

## Returned parameters: other conditions

Appendix B, “Common return codes,” on page 661 lists further combinations of primary and secondary return codes that are common to all NOF verbs.

## QUERY\_DLUR\_PU

---

QUERY\_DLUR\_PU returns information about PUs that use the DLUR feature of CS/AIX.

This verb can be used to obtain information about a specific PU, or about multiple PUs, depending on the options used.

If this verb is issued to an inactive node, it returns information only about PUs defined at the local node; if it is issued to a running node, it also returns information about active downstream PUs using DLUR at this node.

## VCB structure

```
typedef struct query_dlur_pu
{
    AP_UINT16      opcode;                /* verb operation code          */
    unsigned char  reserv2;               /* reserved                      */
    unsigned char  format;                /* reserved                      */
    AP_UINT16      primary_rc;            /* primary return code          */
    AP_UINT32      secondary_rc;          /* secondary return code        */
    unsigned char  *buf_ptr;              /* pointer to buffer            */
    AP_UINT32      buf_size;              /* buffer size                  */
    AP_UINT32      total_buf_size;        /* total buffer size required   */
    AP_UINT16      num_entries;           /* number of entries            */
    AP_UINT16      total_num_entries;     /* total number of entries      */
    unsigned char  list_options;          /* listing options              */
    unsigned char  reserv3;               /* reserved                      */
    unsigned char  pu_name[8];            /* PU name                      */
    unsigned char  dlus_name[17];         /* fully-qualified DLUS name    */
    unsigned char  filter;                /* local / downstream filter    */
} QUERY_DLUR_PU;
```

```
typedef struct dlur_pu_summary
{
    AP_UINT16      overlay_size;          /* size of returned entry       */
    unsigned char  pu_name[8];            /* PU name                      */
    unsigned char  description[32];       /* resource description          */
    unsigned char  reserv1[16];           /* reserved                      */
} DLUR_PU_SUMMARY;
```

```
typedef struct dlur_pu_detail
{
    AP_UINT16      overlay_size;          /* size of returned entry       */
    /* ... (rest of the structure is not visible in the image) ... */
}
```

```

unsigned char    pu_name[8];           /* PU name */
unsigned char    description[32];      /* resource description */
unsigned char    initially_active;     /* is the PU initially active? */
unsigned char    reserv1[15];         /* reserved */
unsigned char    defined_dlus_name[17]; /* defined DLUS name */
unsigned char    bkup_dlus_name[17];  /* backup DLUS name */
unsigned char    pu_id[4];            /* PU identifier */
unsigned char    pu_location;         /* downstream or local PU */
unsigned char    active_dlus_name[17]; /* active DLUS name */
unsigned char    ans_support;         /* auto network shutdown support */
unsigned char    pu_status;           /* status of the PU */
unsigned char    dlus_session_status; /* status of the DLUS pipe */
unsigned char    reserv3;             /* reserved */
FQPCID          fqpcid;              /* FQPCID used on pipe */
AP_UINT16       dlus_retry_timeout;   /* DLUR retry timeout */
AP_UINT16       dlus_retry_limit;    /* DLUR retry limit */
} DLUR_PU_DETAIL;

```

```

typedef struct fqpcid
{
    unsigned char    pcid[8];           /* procedure correlator identifier */
    unsigned char    fqcp_name[17];    /* originator's network qualified */
    unsigned char    reserve3[3];      /* reserved */
} FQPCID;

```

## Supplied parameters

The application supplies the following parameters:

### ***opcode***

AP\_QUERY\_DLUR\_PU

### ***buf\_ptr***

A pointer to a data buffer that CS/AIX will use to return the requested information.

### ***buf\_size***

Size of the supplied data buffer.

### ***num\_entries***

Maximum number of DLUR PUs for which data should be returned. To request data for a specific PU rather than a range, specify the value 1. To return as many entries as possible, specify zero; in this case, CS/AIX will return the maximum number of entries that can be accommodated in the supplied data buffer.

### ***list\_options***

The position in the list from which CS/AIX should begin to return data, and the level of information required for each entry. Specify the level of information with one of the following values:

#### **AP\_SUMMARY**

Summary information only.

#### **AP\_DETAIL**

Detailed information.

Combine this value using a logical OR operation with one of the following values:

#### **AP\_FIRST\_IN\_LIST**

Start at the first entry in the list.

#### **AP\_LIST\_INCLUSIVE**

Start at the entry specified by the *pu\_name* parameter.

#### **AP\_LIST\_FROM\_NEXT**

Start at the entry immediately following the entry specified by the *pu\_name* parameter.

The list is ordered by *pu\_name*. For more information about how the application can obtain specific entries from the list, see [“List options for QUERY\\_\\* Verbs” on page 33](#).

***pu\_name***

Name of the PU for which information is required, or the name to be used as an index into the list of PUs. This value is ignored if *list\_options* is set to AP\_FIRST\_IN\_LIST. The name is an 8-byte EBCDIC type-A string, padded on the right with EBCDIC spaces if the name is shorter than 8 characters.

***dlus\_name***

DLUS name for which PU information is required. To list only information about PUs associated with a specific DLUS, specify the DLUS name; a PU will be listed only if it has an SSCP-PU session to the specified DLUS node. To obtain a complete list for all DLUSs, set this field to binary zeros.

The name is a 17-byte EBCDIC string, right-padded with EBCDIC spaces. It consists of a network ID of up to 8 A-string characters, an EBCDIC dot (period) character, and a network name of up to 8 A-string characters.

***filter***

Specifies whether to filter the returned PUs according to their location.

Allowed values for network node are:

**AP\_INTERNAL**

Return information only for internal PUs.

**AP\_DOWNSTREAM**

Return information only for downstream PUs.

**AP\_NONE**

Return information about all PUs irrespective of location.

For end node, this parameter is reserved (downstream DLUR PUs are not supported).

## Returned parameters: successful execution

If the verb executes successfully, CS/AIX returns the following parameters:

***primary\_rc***

AP\_OK

***buf\_size***

Length of the information returned in the supplied buffer.

***total\_buf\_size***

Returned value indicating the size of buffer that would have been required to return all the list information requested. A value greater than *buf\_size* indicates that not all the available entries were returned.

***num\_entries***

Number of entries returned in the data buffer.

***total\_num\_entries***

Total number of entries available. A value greater than *num\_entries* indicates that not all the available entries were returned.

Each entry in the data buffer consists of the following parameters:

***dlur\_pu\_summary.overlay\_size***

The size of the returned *dlur\_pu\_summary* structure, and therefore the offset to the start of the next entry in the data buffer.

When your application needs to go through the returned buffer to find each *dlur\_pu\_summary* structure in turn, it must use this value to move to the correct offset for the next data structure, and must not use the C `sizeof()` operator. This is because the size of the returned overlay may increase in future releases of CS/AIX; using the returned overlay size ensures that your application will continue to work with future releases.

***dlur\_pu\_summary.pu\_name***

Name of the PU. The name is an 8-byte EBCDIC type-A string, padded on the right with EBCDIC spaces if the name is shorter than 8 characters.



***dlur\_pu\_summary.description***

A null-terminated text string describing the PU, as specified in the definition of the PU. If the PU is an active downstream PU, rather than a defined internal PU, this parameter is reserved.

***dlur\_pu\_detail.overlay\_size***

The size of the returned `dlur_pu_detail` structure, and therefore the offset to the start of the next entry in the data buffer.

When your application needs to go through the returned buffer to find each `dlur_pu_detail` structure in turn, it must use this value to move to the correct offset for the next data structure, and must not use the C `sizeof()` operator. This is because the size of the returned overlay may increase in future releases of CS/AIX; using the returned overlay size ensures that your application will continue to work with future releases.

***dlur\_pu\_detail.pu\_name***

Name of the PU. The name is an 8-byte EBCDIC type-A string, padded on the right with EBCDIC spaces if the name is shorter than 8 characters.

***dlur\_pu\_detail.description***

A null-terminated text string describing the PU, as specified in the definition of the PU. If the PU is an active downstream PU, rather than a defined internal PU, this parameter is reserved.

***dlur\_pu\_detail.initially\_active***

Specifies whether this PU is automatically started when the node is started. For a downstream PU, this parameter is reserved. Possible values for an internal PU are:

**AP\_YES**

The PU is automatically started when the node is started.

**AP\_NO**

The PU is not automatically started; it must be started manually.

***dlur\_pu\_detail.defined\_dlus\_name***

Name of DLUS node, defined by either a `DEFINE_INTERNAL_PU` verb or a `DEFINE_LS` verb (with `dspu_services` set to `AP_DLUR`).

The name is a 17-byte EBCDIC string, right-padded with EBCDIC spaces. It consists of a network ID of up to 8 A-string characters, an EBCDIC dot (period) character, and a network name of up to 8 A-string characters.

***dlur\_pu\_detail.bkup\_dlus\_name***

Name of backup DLUS node, defined by either a `DEFINE_INTERNAL_PU` verb or a `DEFINE_LS` verb (with `dspu_services` set to `AP_DLUR`).

The name is a 17-byte EBCDIC string, right-padded with EBCDIC spaces. It consists of a network ID of up to 8 A-string characters, an EBCDIC dot (period) character, and a network name of up to 8 A-string characters.

***dlur\_pu\_detail.pu\_id***

PU identifier, either defined on `DEFINE_INTERNAL_PU` or obtained in an `XID` from a downstream PU. This is a 4-byte hexadecimal string, consisting of a block number (3 hexadecimal digits) and a node number (5 hexadecimal digits).

***dlur\_pu\_detail.pu\_location***

Location of PU.

This is set to one of the following.

**AP\_INTERNAL**

PU is on the local node.

**AP\_DOWNSTREAM**

PU is on a downstream node (network node only).

***dlur\_pu\_detail.active\_dlus\_name***

Name of DLUS node that the PU is currently using. If the SSCP-PU session is not active, this field will be set to all binary zeros.

The name is a 17-byte EBCDIC string, right-padded with EBCDIC spaces. It consists of a network ID of up to 8 A-string characters, an EBCDIC dot (period) character, and a network name of up to 8 A-string characters.

***dlur\_pu\_detail.ans\_support***

Auto Network Shutdown support, as sent to DLUR from the DLUS at SSCP-PU activation. It specifies whether link-level contact should be continued if the subarea node initiates an auto network shutdown procedure for the SSCP controlling the PU. Possible values are:

**AP\_CONT**

Continue link-level contact

**AP\_STOP**

Stop link-level contact.

This field is reserved if the SSCP-LU session is inactive.

***dlur\_pu\_detail.pu\_status***

Status of the PU (as seen by DLUR). Possible values are:

**AP\_RESET**

The PU is in reset state.

**AP\_PEND\_ACTPU**

The PU is waiting for an ACTPU from the host.

**AP\_PEND\_ACTPU\_RSP**

Having forwarded an ACTPU to the PU, DLUR is now waiting for the PU to respond to it.

**AP\_ACTIVE**

The PU is active.

**AP\_PEND\_DACTPU\_RSP**

Having forwarded a DACTPU to the PU, DLUR is waiting for the PU to respond to it.

**AP\_PEND\_INOP**

DLUR is waiting for all necessary events to complete before it deactivates the PU.

***dlur\_pu\_detail.dlus\_session\_status***

Status of the DLUS pipe currently being used by the PU. Possible values are:

**AP\_PENDING\_ACTIVE**

The pipe is in the process of being activated.

**AP\_ACTIVE**

The pipe is active.

**AP\_PENDING\_INACTIVE**

The pipe is in the process of being deactivated.

**AP\_INACTIVE**

The pipe is not active.

***dlur\_pu\_detail.fqpcid.pcid***

Procedure Correlator ID used on the pipe. This is an 8-byte hexadecimal string. If the SSCP-PU session is not active this field will be set to binary zeros.

***dlur\_pu\_detail.fqpcid.fqcp\_name***

Fully qualified Control Point name used on the pipe. If the SSCP-PU session is not active this field will be set to binary zeros.

The name is a 17-byte EBCDIC string, right-padded with EBCDIC spaces. It consists of a network ID of up to 8 A-string characters, an EBCDIC dot (period) character, and a network name of up to 8 A-string characters.

The combination of the *pcid* and *fqcp\_name* parameters uniquely identify each PU whose sessions are being routed using DLUR. The *fqcp\_name* parameter is the CP name of either the DLUR or DLUS node, depending on which node initiated the SSCP-PU session activation.

***dlur\_pu\_detail.dlus\_retry\_timeout***

The interval in seconds between the second and subsequent attempts to contact the DLUS specified by the *def\_data.dlus\_name* and *def\_data.bkup\_dlus\_name* parameters. The interval between the first and second attempts is always 1 second. If zero is specified, then the defaults specified using the DEFINE\_DLUR\_DEFAULTS verb are used. .

***dlur\_pu\_detail.dlus\_retry\_limit***

Number of attempts to recontact a DLUS after an initial failure. A value of zero indicates that the value from the DEFINE\_DLUR\_DEFAULTS verb is used. If 0xFFFF is returned, CS/AIX will retry indefinitely.

**Returned parameters: parameter check**

If the verb does not execute because of a parameter error, CS/AIX returns the following parameters:

***primary\_rc***

AP\_PARAMETER\_CHECK

***secondary\_rc***

Possible values are:

**AP\_INVALID\_PU\_NAME**

The *list\_options* parameter was set to AP\_LIST\_INCLUSIVE to list all entries starting from the supplied name, but the *pu\_name* parameter was not valid.

**AP\_INVALID\_FILTER\_OPTION**

The *filter* parameter was not set to a valid value.

**AP\_INVALID\_LIST\_OPTION**

The *list\_options* parameter was not set to a valid value.

Appendix B, “Common return codes,” on page 661 lists further secondary return codes associated with AP\_PARAMETER\_CHECK, which are common to all NOF verbs.

**Returned parameters: function not supported**

If the verb does not execute successfully because the local node configuration does not support it, CS/AIX returns the following parameters:

***primary\_rc*****AP\_FUNCTION\_NOT\_SUPPORTED**

The local node does not support DLUR; this is defined by the *dlur\_support* parameter on the DEFINE\_NODE verb.

**Returned parameters: other conditions**

Appendix B, “Common return codes,” on page 661 lists further combinations of primary and secondary return codes that are common to all NOF verbs.

**QUERY\_DLUS**

QUERY\_DLUS returns information about DLUS nodes known to the DLUR feature of CS/AIX. This verb returns pipe statistics (SSCP-PU and SSCP-LU session statistics); the QUERY\_ISR\_SESSION verb may be used to obtain PLU-SLU session statistics.

This verb can be used to obtain information about a specific DLUS, or about multiple DLUSs, depending on the options used.

If this verb is issued to an inactive node, it returns information only on DLUS nodes defined using DEFINE\_INTERNAL\_PU or DEFINE\_DLUR\_DEFAULTS; if it is issued to a running node, it also returns information about active DLUS nodes. It does not return information about the backup DLUS that was defined using DEFINE\_DLUR\_DEFAULTS, unless this DLUS is active.

## VCB structure

```
typedef struct query_dlus
{
    AP_UINT16      opcode;                /* verb operation code          */
    unsigned char  reserv2;               /* reserved                      */
    unsigned char  format;                /* reserved                      */
    AP_UINT16      primary_rc;            /* primary return code          */
    AP_UINT32      secondary_rc;          /* secondary return code        */
    unsigned char  *buf_ptr;              /* pointer to buffer            */
    AP_UINT32      buf_size;              /* buffer size                  */
    AP_UINT32      total_buf_size;        /* total buffer size required    */
    AP_UINT16      num_entries;           /* number of entries            */
    AP_UINT16      total_num_entries;     /* total number of entries      */
    unsigned char  list_options;          /* listing options              */
    unsigned char  reserv3;               /* reserved                      */
    unsigned char  dlus_name[17];         /* fully-qualified DLUS name    */
} QUERY_DLUS;
```

```
typedef struct dlus_data
{
    AP_UINT16      overlay_size;          /* size of returned entry       */
    unsigned char  dlus_name[17];         /* fully qualified DLUS name    */
    unsigned char  is_default;            /* is the DLUS the default      */
    unsigned char  is_backup_default;     /* is DLUS the backup default   */
    unsigned char  pipe_state;            /* state of CPSVRMGR pipe       */
    AP_UINT16      num_active_pus;        /* num of active PUs using pipe */
    PIPE_STATS     pipe_stats;            /* pipe statistics              */
    unsigned char  persistent_pipe_support; /* reserved                      */
    unsigned char  persistent_pipe;       /* reserved                      */
} DLUS_DATA;
```

```
typedef struct pipe_stats
{
    AP_UINT32      reqactpu_sent;          /* REQACTPUs sent to DLUS      */
    AP_UINT32      reqactpu_rsp_received; /* RSP(REQACTPU)s received     */
    /* from DLUS */
    AP_UINT32      actpu_received;         /* ACTPUs received from DLUS   */
    AP_UINT32      actpu_rsp_sent;         /* RSP(ACTPU)s sent to DLUS    */
    AP_UINT32      reqdactpu_sent;         /* REQDACTPUs sent to DLUS     */
    AP_UINT32      reqdactpu_rsp_received; /* RSP(REQDACTPU)s received    */
    /* from DLUS */
    AP_UINT32      dactpu_received;        /* DACTPUs received from DLUS  */
    AP_UINT32      dactpu_rsp_sent;        /* RSP(DACTPU)s sent to DLUS   */
    AP_UINT32      actlu_received;         /* ACTLUs received from DLUS   */
    AP_UINT32      actlu_rsp_sent;         /* RSP(ACTLU)s sent to DLUS    */
    AP_UINT32      dactlu_received;        /* DACTLUs received from DLUS  */
    AP_UINT32      dactlu_rsp_sent;        /* RSP(DACTLU)s sent to DLUS   */
    AP_UINT32      sscp_pu_mus_rcvd;       /* MUs for SSCP-PU sessions rcvd */
    AP_UINT32      sscp_pu_mus_sent;       /* MUs for SSCP-PU sessions sent */
    AP_UINT32      sscp_lu_mus_rcvd;       /* MUs for SSCP-LU sessions rcvd */
    AP_UINT32      sscp_lu_mus_sent;       /* MUs for SSCP-LU sessions sent */
} PIPE_STATS;
```

## Supplied parameters

The application supplies the following parameters:

### **opcode**

AP\_QUERY\_DLUS

### **buf\_ptr**

A pointer to a data buffer that CS/AIX will use to return the requested information.

### **buf\_size**

Size of the supplied data buffer.

### **num\_entries**

Maximum number of DLUSs for which data should be returned. To request data for a specific DLUS rather than a range, specify the value 1. To return as many entries as possible, specify zero; in this case, CS/AIX will return the maximum number of entries that can be accommodated in the supplied data buffer.

***list\_options***

The position in the list from which CS/AIX should begin to return data. Specify one of the following values:

**AP\_FIRST\_IN\_LIST**

Start at the first entry in the list.

**AP\_LIST\_INCLUSIVE**

Start at the entry specified by the *dlus\_name* parameter.

**AP\_LIST\_FROM\_NEXT**

Start at the entry immediately following the entry specified by the *dlus\_name* parameter.

The list is ordered by *dlus\_name*. For more information about how the application can obtain specific entries from the list, see [“List options for QUERY\\_\\* Verbs” on page 33](#).

***dlus\_name***

Name of the DLUS for which information is required, or the name to be used as an index into the list of DLUSs. This value is ignored if *list\_options* is set to AP\_FIRST\_IN\_LIST.

The name is a 17-byte EBCDIC string, right-padded with EBCDIC spaces. It consists of a network ID of up to 8 A-string characters, an EBCDIC dot (period) character, and a network name of up to 8 A-string characters.

## Returned parameters: successful execution

If the verb executes successfully, CS/AIX returns the following parameters:

***primary\_rc***

AP\_OK

***buf\_size***

Length of the information returned in the supplied buffer.

***total\_buf\_size***

Returned value indicating the size of buffer that would have been required to return all the list information requested. A value greater than *buf\_size* indicates that not all the available entries were returned.

***num\_entries***

Number of entries returned in the data buffer.

***total\_num\_entries***

Total number of entries available. A value greater than *num\_entries* indicates that not all the available entries were returned.

Each entry in the data buffer consists of the following parameters:

***dlus\_data.overlay\_size***

The size of the returned *dlus\_data* structure, and therefore the offset to the start of the next entry in the data buffer.

When your application needs to go through the returned buffer to find each *dlus\_data* structure in turn, it must use this value to move to the correct offset for the next data structure, and must not use the C `sizeof()` operator. This is because the size of the returned overlay may increase in future releases of CS/AIX; using the returned overlay size ensures that your application will continue to work with future releases.

***dlus\_data.dlus\_name***

Name of DLUS. The name is a 17-byte EBCDIC string, right-padded with EBCDIC spaces. It consists of a network ID of up to 8 A-string characters, an EBCDIC dot (period) character, and a network name of up to 8 A-string characters.

***dlus\_data.is\_default***

Specifies whether the DLUS node has been designated as the default by a DEFINE\_DLUR\_DEFAULTS verb (AP\_YES or AP\_NO).

***dlus\_data.is\_backup\_default***

Specifies whether the DLUS node has been designated as the backup default by a DEFINE\_DLUR\_DEFAULTS verb (AP\_YES or AP\_NO).

***dlus\_data.pipe\_state***

State of the pipe to the DLUS. Possible values are:

**AP\_PENDING\_ACTIVE**

The pipe is in the process of being activated.

**AP\_ACTIVE**

The pipe is active.

**AP\_PENDING\_INACTIVE**

The pipe is in the process of being deactivated.

**AP\_INACTIVE**

The pipe is not active.

***dlus\_data.num\_active\_pus***

Number of PUs currently using the pipe to the DLUS.

***dlus\_data.pipe\_stats.reqactpu\_sent***

Number of REQACTPUs sent to DLUS over the pipe.

***dlus\_data.pipe\_stats.reqactpu\_rsp\_received***

Number of RSP(REQACTPU)s received from DLUS over the pipe.

***dlus\_data.pipe\_stats.actpu\_received***

Number of ACTPUs received from DLUS over the pipe.

***dlus\_data.pipe\_stats.actpu\_rsp\_sent***

Number of RSP(ACTPU)s sent to DLUS over the pipe.

***dlus\_data.pipe\_stats.reqdactpu\_sent***

Number of REQDACTPUs sent to DLUS over the pipe.

***dlus\_data.pipe\_stats.reqdactpu\_rsp\_received***

Number of RSP(REQDACTPU)s received from DLUS over the pipe.

***dlus\_data.pipe\_stats.dactpu\_received***

Number of DACTPUs received from DLUS over the pipe.

***dlus\_data.pipe\_stats.dactpu\_rsp\_sent***

Number of RSP(DACTPU)s sent to DLUS over the pipe.

***dlus\_data.pipe\_stats.actlu\_received***

Number of ACTLUs received from DLUS over the pipe.

***dlus\_data.pipe\_stats.actlu\_rsp\_sent***

Number of RSP(ACTLU)s sent to DLUS over the pipe.

***dlus\_data.pipe\_stats.dactlu\_received***

Number of DACTLUs received from DLUS over the pipe.

***dlus\_data.pipe\_stats.dactlu\_rsp\_sent***

Number of RSP(DACTLU)s sent to DLUS over the pipe.

***dlus\_data.pipe\_stats.sscp\_pu\_mus\_rcvd***

Number of SSCP-PU MUs received from DLUS over the pipe.

***dlus\_data.pipe\_stats.sscp\_pu\_mus\_sent***

Number of SSCP-PU MUs sent to DLUS over the pipe.

***dlus\_data.pipe\_stats.sscp\_lu\_mus\_rcvd***

Number of SSCP-LU MUs received from DLUS over the pipe.

***dlus\_data.pipe\_stats.sscp\_lu\_mus\_sent***

Number of SSCP-LU MUs sent to DLUS over the pipe.

## Returned parameters: parameter check

If the verb does not execute because of a parameter error, CS/AIX returns the following parameters:

### *primary\_rc*

AP\_PARAMETER\_CHECK

### *secondary\_rc*

Possible values are:

#### **AP\_INVALID\_DLUS\_NAME**

The *list\_options* parameter was set to AP\_LIST\_INCLUSIVE, to list all entries starting from the supplied name, but the *dlus\_name* parameter was not valid.

#### **AP\_INVALID\_LIST\_OPTION**

The *list\_options* parameter was not set to a valid value.

Appendix B, “Common return codes,” on page 661 lists further secondary return codes associated with AP\_PARAMETER\_CHECK, which are common to all NOF verbs.

## Returned parameters: function not supported

If the verb does not execute successfully because the local node configuration does not support it, CS/AIX returns the following parameters:

### *primary\_rc*

#### **AP\_FUNCTION\_NOT\_SUPPORTED**

The local node does not support DLUR; this is defined by the *dlur\_support* parameter on the DEFINE\_NODE verb.

## Returned parameters: other conditions

Appendix B, “Common return codes,” on page 661 lists further combinations of primary and secondary return codes that are common to all NOF verbs.

## QUERY\_DOMAIN\_CONFIG\_FILE

QUERY\_DOMAIN\_CONFIG\_FILE returns the header information included in the CS/AIX domain configuration file (the CS/AIX version number, the revision level of the file, and an optional comment string supplied on DEFINE\_DOMAIN\_CONFIG\_FILE).

This verb must be issued to the domain configuration file.

## VCB structure

```
typedef struct query_domain_config_file
{
    AP_UINT16          opcode;           /* verb operation code    */
    unsigned char     reserv2;          /* reserved               */
    unsigned char     format;          /* reserved               */
    AP_UINT16          primary_rc;      /* primary return code    */
    AP_UINT32          secondary_rc;    /* secondary return code  */
    unsigned char     reserv3[8];      /* Reserved               */
    CONFIG_FILE_HEADER hdr;
} QUERY_DOMAIN_CONFIG_FILE;
```

```
typedef struct config_file_header
{
    AP_UINT16          major_version;   /* major version number   */
    AP_UINT16          minor_version;  /* minor version number   */
    AP_UINT16          update_release; /* update release         */
    AP_UINT32          revision_level; /* file revision number   */
    unsigned char     comment[100];    /* optional comment string */
    AP_UINT16          updating;       /* reserved               */
} CONFIG_FILE_HEADER;
```

## Supplied parameters

The application supplies the following parameter:

***opcode***

AP\_QUERY\_DOMAIN\_CONFIG\_FILE

## Returned parameters: successful execution

If the verb executes successfully, CS/AIX returns the following parameters:

***primary\_rc***

AP\_OK

***hdr.major\_version, hdr.minor\_version, hdr.update\_release***

The internal version identifier of the release of CS/AIX that was used to create this file.

***hdr.revision\_level***

The revision level of the file (stored internally by CS/AIX).

***hdr.comment***

An optional comment string containing information about the file. This is an ASCII string of 0-99 characters, followed by a null character.

## Returned parameters: other conditions

Appendix B, “Common return codes,” on page 661 lists further combinations of primary and secondary return codes that are common to all NOF verbs.

## QUERY\_DOWNSTREAM\_LU

---

QUERY\_DOWNSTREAM\_LU returns information about downstream LUs that use SNA gateway or DLUR or both. It also returns information about downstream LUs used by applications that communicates with a CS/AIX Primary RUI application. For more information about Primary RUI, see IBM Communications Server for Data Center Deployment on AIX or Linux LUA Programmer's Guide.

The returned information is structured as determined data (data gathered dynamically during execution, returned only if the node is active) and defined data (data supplied on DEFINE\_DOWNSTREAM\_LU). For DLUR-supported LUs, implicitly defined data is put in place when the downstream LU is activated.

This verb can be used to obtain information about a specific LU, or about multiple LUs, depending on the options used.

## VCB structure

```
typedef struct query_downstream_lu
{
    AP_UINT16      opcode;                /* verb operation code      */
    unsigned char  reserv2;               /* reserved                  */
    unsigned char  format;                /* reserved                  */
    AP_UINT16      primary_rc;            /* primary return code      */
    AP_UINT32      secondary_rc;          /* secondary return code    */
    unsigned char  *buf_ptr;              /* pointer to buffer        */
    AP_UINT32      buf_size;              /* buffer size              */
    AP_UINT32      total_buf_size;        /* total buffer size required */
    AP_UINT16      num_entries;           /* number of entries        */
    AP_UINT16      total_num_entries;     /* total number of entries  */
    unsigned char  list_options;          /* listing options          */
    unsigned char  reserv3;               /* reserved                  */
    unsigned char  dspu_name[8];          /* Downstream PU name filter */
    unsigned char  dslu_name[8];          /* Downstream LU name       */
    unsigned char  dspu_services;         /* services provided to LU  */
} QUERY_DOWNSTREAM_LU;
```

```
typedef struct downstream_lu_summary
{
    AP_UINT16      overlay_size;          /* size of returned entry   */
}
```



```

unsigned char    dspu_name[8];           /* PU name */
unsigned char    dslu_name[8];          /* LU name */
unsigned char    description[32];       /* resource description */
unsigned char    reserv1[16];           /* reserved */
unsigned char    dspu_services;         /* Type of services provided
                                         to downstream LU */

unsigned char    nau_address;           /* NAU address */
unsigned char    lu_sscp_sess_active;   /* Is LU-SSCP session active */
unsigned char    plu_sess_active;       /* Is PLU-SLU session active */
} DOWNSTREAM_LU_SUMMARY;

```

```

typedef struct downstream_lu_detail
{
    AP_UINT16     overlay_size;          /* size of returned entry */
    unsigned char dslu_name[8];          /* LU name */
    unsigned char reserv1[2];            /* reserved */
    DOWNSTREAM_LU_DET_DATA det_data;     /* Determined data */
    DOWNSTREAM_LU_DEF_DATA def_data;     /* Defined data */
} DOWNSTREAM_LU_DETAIL;

```

```

typedef struct downstream_lu_det_data
{
    unsigned char lu_sscp_sess_active;   /* Is LU-SSCP session active */
    unsigned char plu_sess_active;       /* Is PLU-SLU session active */
    unsigned char dspu_services;         /* Type of service provided to
                                         downstream node */
    unsigned char reserv1;                /* reserved */
    SESSION_STATS lu_sscp_stats;          /* LU-SSCP session statistics */
    SESSION_STATS ds_plu_stats;           /* Downstream PLU-SLU session
                                         statistics */
    SESSION_STATS us_plu_stats;           /* Upstream PLU-SLU session
                                         statistics */
    unsigned char host_lu_name[8];        /* Determined host LU name */
    unsigned char host_pu_name[8];        /* Determined host PU name */

    unsigned char reserva[4];             /* reserved */
} DOWNSTREAM_LU_DET_DATA;

```

```

typedef struct downstream_lu_def_data
{
    unsigned char description[32];        /* resource description */
    unsigned char reserv1[16];            /* reserved */
    unsigned char nau_address;            /* downstream LU nau address */
    unsigned char dspu_name[8];           /* Downstream PU name */
    unsigned char host_lu_name[8];        /* Host LU or Pool name */
    unsigned char allow_timeout;          /* Allow timeout of host LU */
    unsigned char delayed_logon;          /* Allow delayed logon to
                                         host LU */
    unsigned char reserv2[6];             /* reserved */
} DOWNSTREAM_LU_DEF_DATA;

```

```

typedef struct session_stats
{
    AP_UINT16     rcv_ru_size;            /* session receive RU size */
    AP_UINT16     send_ru_size;           /* session send RU size */
    AP_UINT16     max_send_btu_size;      /* maximum send BTU size */
    AP_UINT16     max_rcv_btu_size;       /* maximum rcv BTU size */
    AP_UINT16     max_send_pac_win;       /* maximum send pacing window size */
    AP_UINT16     cur_send_pac_win;       /* current send pacing window size */
    AP_UINT16     max_rcv_pac_win;        /* maximum receive pacing window size */
    AP_UINT16     cur_rcv_pac_win;        /* current receive pacing window size */
    AP_UINT32     send_data_frames;       /* number of data frames sent */
    AP_UINT32     send_fmd_data_frames;   /* num fmd data frames sent */
    AP_UINT32     send_data_bytes;        /* number of data bytes sent */
    AP_UINT32     rcv_data_frames;        /* number of data frames received */
    AP_UINT32     rcv_fmd_data_frames;    /* num fmd data frames received */
    AP_UINT32     rcv_data_bytes;         /* number of data bytes received */
    unsigned char sidh;                   /* session ID high byte (from LFSID) */
    unsigned char sidl;                   /* session ID low byte (from LFSID) */
    unsigned char odai;                   /* ODAI bit set */
    unsigned char ls_name[8];              /* Link station name */
    unsigned char pacing_type;            /* type of pacing in use */
} SESSION_STATS;

```

## Supplied parameters

The application supplies the following parameters:

### ***opcode***

AP\_QUERY\_DOWNSTREAM\_LU

### ***buf\_ptr***

A pointer to a data buffer that CS/AIX will use to return the requested information.

### ***buf\_size***

Size of the supplied data buffer.

### ***num\_entries***

Maximum number of downstream LUs for which data should be returned. To request data for a specific LU rather than a range, specify the value 1. To return as many entries as possible, specify zero; in this case, CS/AIX will return the maximum number of entries that can be accommodated in the supplied data buffer.

### ***list\_options***

The position in the list from which CS/AIX should begin to return data, and the level of information required for each entry. Specify the level of information with one of the following values:

#### **AP\_SUMMARY**

Summary information only.

#### **AP\_DETAIL**

Detailed information.

Combine this value using a logical OR operation with one of the following values:

#### **AP\_FIRST\_IN\_LIST**

Start at the first entry in the list.

#### **AP\_LIST\_INCLUSIVE**

Start at the entry specified by the combination of the *dspu\_name* and *dslu\_name* parameters.

#### **AP\_LIST\_FROM\_NEXT**

Start at the entry immediately following the entry specified by the combination of the *dspu\_name* and *dslu\_name* parameters.

The list is ordered by *dspu\_name* and then by *dslu\_name*. For more information about how the application can obtain specific entries from the list, see [“List options for QUERY\\_\\* Verbs” on page 33](#).

### ***dspu\_name***

PU name for which LU information is required (as specified on DEFINE\_LS). To list only information about LUs associated with a specific PU, specify the PU name. To obtain a complete list for all PUs, set this field to binary zeros. The name is an 8-byte EBCDIC type-A string, padded on the right with EBCDIC spaces if the name is shorter than 8 characters.

### ***dslu\_name***

Name of the LU for which information is required, or the name to be used as an index into the list of LUs. This value is ignored if *list\_options* is set to AP\_FIRST\_IN\_LIST. The name is an 8-byte EBCDIC type-A string, padded on the right with EBCDIC spaces if the name is shorter than 8 characters.

### ***dspu\_services***

DSPU services filter. When the verb is issued to a running node, this parameter specifies whether to filter the returned information by the type of services provided to the LUs. Possible values are:

#### **AP\_PU\_CONCENTRATION**

Return information only on downstream LUs served by SNA gateway.

#### **AP\_DLUR**

Return information only on downstream LUs served by DLUR.

#### **AP\_NONE**

Return information about all downstream LUs.

When the node is not running, this parameter is ignored; CS/AIX returns information about all downstream LUs.

## Returned parameters: successful execution

If the verb executes successfully, CS/AIX returns the following parameters:

### ***primary\_rc***

AP\_OK

### ***buf\_size***

Length of the information returned in the supplied buffer.

### ***total\_buf\_size***

Returned value indicating the size of buffer that would have been required to return all the list information requested. A value greater than *buf\_size* indicates that not all the available entries were returned.

### ***num\_entries***

Number of entries returned in the data buffer.

### ***total\_num\_entries***

Total number of entries available. A value greater than *num\_entries* indicates that not all the available entries were returned.

Each entry in the data buffer consists of the following parameters:

### ***downstream\_lu\_summary.overlay\_size***

The size of the returned *downstream\_lu\_summary* structure, and therefore the offset to the start of the next entry in the data buffer.

When your application needs to go through the returned buffer to find each *downstream\_lu\_summary* structure in turn, it must use this value to move to the correct offset for the next data structure, and must not use the C `sizeof()` operator. This is because the size of the returned overlay may increase in future releases of CS/AIX; using the returned overlay size ensures that your application will continue to work with future releases.

### ***downstream\_lu\_summary.dspu\_name***

Name of the PU associated with the LU. The name is an 8-byte EBCDIC type-A string, padded on the right with EBCDIC spaces if the name is shorter than 8 characters.

### ***downstream\_lu\_summary.dslu\_name***

Name of the LU. The name is an 8-byte EBCDIC type-A string, padded on the right with EBCDIC spaces if the name is shorter than 8 characters.

### ***downstream\_lu\_summary.description***

A null-terminated text string describing the downstream LU, as specified in the definition of the downstream LU.

For a DLUR-supported LU, this parameter is reserved.

### ***downstream\_lu\_summary.dspu\_services***

When the verb is issued to a running node, this parameter specifies the services provided by the local node to the downstream LU.

Possible values are:

#### **AP\_PU\_CONCENTRATION**

Downstream LU is served by SNA gateway.

#### **AP\_DLUR**

Downstream LU is served by DLUR.

### ***downstream\_lu\_summary.nau\_address***

Network accessible unit address of the LU.

### ***downstream\_lu\_summary.lu\_sscp\_sess\_active***

Specifies whether the LU-SSCP session is active. Possible values are:

**AP\_YES**

The session is active.

**AP\_NO**

The session is not active.

***downstream\_lu\_summary.plu\_sess\_active***

Specifies whether the PLU-SLU session is active. Possible values are:

**AP\_YES**

The session is active.

**AP\_NO**

The session is not active.

***downstream\_lu\_detail.overlay\_size***

The size of the returned `downstream_lu_detail` structure, and therefore the offset to the start of the next entry in the data buffer.

When your application needs to go through the returned buffer to find each `downstream_lu_detail` structure in turn, it must use this value to move to the correct offset for the next data structure, and must not use the C `sizeof()` operator. This is because the size of the returned overlay may increase in future releases of CS/AIX; using the returned overlay size ensures that your application will continue to work with future releases.

***downstream\_lu\_detail.dslu\_name***

Name of the LU. The name is an 8-byte EBCDIC type-A string, padded on the right with EBCDIC spaces if the name is shorter than 8 characters.

***downstream\_lu\_detail.det\_data.lu\_sscp\_sess\_active***

Specifies whether the LU-SSCP session is active. Possible values are:

**AP\_YES**

The session is active.

**AP\_NO**

The session is not active.

***downstream\_lu\_detail.det\_data.plu\_sess\_active***

Specifies whether the PLU-SLU session is active. Possible values are:

**AP\_YES**

The session is active.

**AP\_NO**

The session is not active.

***downstream\_lu\_detail.det\_data.dspu\_services***

When the verb is issued to a running node, this parameter specifies the services provided by the local node to the downstream LU.

Possible values are:

**AP\_PU\_CONCENTRATION**

Downstream LU is served by SNA gateway.

**AP\_DLUR**

Downstream LU is served by DLUR.

A `session_stats` structure is included for each of the three sessions (LU-SSCP session, downstream PLU-SLU session, and upstream PLU-SLU session). The fields in this structure are as follows:

***rcv\_ru\_size***

Maximum receive RU size. (In the LU-SSCP session statistics, this parameter is reserved.)

***send\_ru\_size***

Maximum send RU size. (In the LU-SSCP session statistics, this parameter is reserved.)

**max\_send\_btu\_size**

Maximum BTU size that can be sent.

**max\_rcv\_btu\_size**

Maximum BTU size that can be received.

**max\_send\_pac\_win**

Maximum size of the send pacing window on this session. (In the LU-SSCP session statistics, this parameter is reserved.)

**cur\_send\_pac\_win**

Current size of the send pacing window on this session. (In the LU-SSCP session statistics, this parameter is reserved.)

**max\_rcv\_pac\_win**

Maximum size of the receive pacing window on this session. (In the LU-SSCP session statistics, this parameter is reserved.)

**cur\_rcv\_pac\_win**

Current size of the receive pacing window on this session. (In the LU-SSCP session statistics, this parameter is reserved.)

**send\_data\_frames**

Number of normal flow data frames sent.

**send\_fmd\_data\_frames**

Number of normal flow FMD data frames sent.

**send\_data\_bytes**

Number of normal flow data bytes sent.

**rcv\_data\_frames**

Number of normal flow data frames received.

**rcv\_fmd\_data\_frames**

Number of normal flow FMD data frames received.

**rcv\_data\_bytes**

Number of normal flow data bytes received.

**sidh**

Session ID high byte. (In the upstream PLU-SLU session statistics for an LU served by SNA gateway, this parameter is reserved.)

**sidl**

Session ID low byte. (In the upstream PLU-SLU session statistics for an LU served by SNA gateway, this parameter is reserved.)

**odai**

Origin Destination Assignor Indicator. When bringing up a session, the sender of the BIND sets this field to zero if the local node contains the primary link station, and sets it to one if the BIND sender is the node containing the secondary link station. (In the upstream PLU-SLU session statistics for an LU served by SNA gateway, this parameter is reserved.)

**ls\_name**

Link station name associated with statistics. This is an 8-byte ASCII character string, right-padded with spaces if the name is shorter than 8 characters. (In the upstream PLU-SLU session statistics for an LU served by SNA gateway, this parameter is reserved.)

**pacing\_type**

The type of receive pacing in use on this session. Possible values are:

- AP\_NONE
- AP\_PACING\_FIXED

**downstream\_lu\_detail.det\_data.host\_lu\_name**

Name of the host LU to which the downstream LU is mapped, or to which it was mapped when the PLU-SLU session was last active. This parameter value may differ from *def\_data.host\_lu\_name* because *def\_data.host\_lu\_name* can be the name of a host LU pool.

## QUERY\_DOWNSTREAM\_LU

If the downstream LU is used to communicate with a CS/AIX Primary RUI application instead of a host, this field is set to the string #PRIRUI# in EBCDIC.

### ***downstream\_lu\_detail.det\_data.host\_pu\_name***

Name of the host PU to which the downstream LU is mapped, or to which it was mapped when the PLU-SLU session was last active.

### ***downstream\_lu\_detail.def\_data.description***

A null-terminated text string describing the downstream LU, as specified in the definition of the downstream LU. For a DLUR-supported LU, this parameter is reserved.

### ***downstream\_lu\_detail.def\_data.nau\_address***

Network accessible unit address of the downstream LU.

### ***downstream\_lu\_detail.def\_data.dspu\_name***

Name of the downstream PU associated with this LU (as specified on the DEFINE\_LS verb). This is an 8-byte type-A EBCDIC string (starting with a letter), padded on the right with EBCDIC spaces if the name is shorter than 8 characters.

### ***downstream\_lu\_detail.def\_data.host\_lu\_name***

Name of the host LU or host LU pool that the downstream LU uses. This is an 8-byte EBCDIC string, padded on the right with EBCDIC spaces if the name is shorter than 8 characters.

If the downstream LU is used to communicate with a CS/AIX Primary RUI application instead of a host, this field is set to the string #PRIRUI# in EBCDIC.

This field is reserved for DLUR-served downstream LUs.

### ***downstream\_lu\_detail.allow\_timeout***

Specifies whether this downstream LU allows its session with the upstream LU to timeout. Possible values are:

#### **AP\_YES**

This downstream LU allows its session with the upstream LU to timeout.

#### **AP\_NO**

This downstream LU does not allow its session with the upstream LU to timeout.

This field is ignored if the downstream LU is used to communicate with a CS/AIX Primary RUI application instead of a host.

### ***downstream\_lu\_detail.delayed\_logon***

Specifies whether this downstream LU uses delayed logon (the upstream LU is not activated until the user requests that it be activated). Possible values are:

#### **AP\_YES**

This downstream LU uses delayed logon.

#### **AP\_NO**

This downstream LU does not use delayed logon.

This field is ignored if the downstream LU is used to communicate with a CS/AIX Primary RUI application instead of a host.

## Returned parameters: parameter check

If the verb does not execute because of a parameter error, CS/AIX returns the following parameters:

### ***primary\_rc***

AP\_PARAMETER\_CHECK

### ***secondary\_rc***

Possible values are:

#### **AP\_INVALID\_LU\_NAME**

The *list\_options* parameter was set to AP\_LIST\_INCLUSIVE, to list all entries starting from the supplied name, but the *lu\_name* parameter was not valid.

**AP\_INVALID\_LIST\_OPTION**

The *list\_options* parameter was not set to a valid value.

Appendix B, “Common return codes,” on page 661 lists further secondary return codes associated with AP\_PARAMETER\_CHECK, which are common to all NOF verbs.

**Returned parameters: state check**

If the verb does not execute because of a state error, CS/AIX returns the following parameters.

**primary\_rc**

AP\_STATE\_CHECK

**secondary\_rc****AP\_INVALID\_PU\_TYPE**

The PU specified by the *dspu\_name* parameter is not a downstream PU.

Appendix B, “Common return codes,” on page 661 lists further secondary return codes associated with AP\_STATE\_CHECK, which are common to all NOF verbs.

**Returned parameters: function not supported**

If the verb does not execute successfully because the local node configuration does not support it, CS/AIX returns the following parameters:

**primary\_rc****AP\_FUNCTION\_NOT\_SUPPORTED**

The local node does not support SNA gateway or DLUR; this is defined by the *pu\_conc\_supportand dlur\_support* parameters on the DEFINE\_NODE verb.

**Returned parameters: other conditions**

Appendix B, “Common return codes,” on page 661 lists further combinations of primary and secondary return codes that are common to all NOF verbs.

**QUERY\_DOWNSTREAM\_PU**

QUERY\_DOWNSTREAM\_PU returns information about downstream PUs that use SNA gateway or DLUR or both. This verb can be used to obtain information about a specific PU or about multiple PUs, depending on the options used.

This verb must be issued to a running node.

**VCB structure**

```
typedef struct query_downstream_pu
{
    AP_UINT16      opcode;                /* verb operation code          */
    unsigned char  reserv2;               /* reserved                      */
    unsigned char  format;               /* reserved                      */
    AP_UINT16      primary_rc;           /* primary return code          */
    AP_UINT32      secondary_rc;        /* secondary return code        */
    unsigned char  *buf_ptr;             /* pointer to buffer            */
    AP_UINT32      buf_size;             /* buffer size                  */
    AP_UINT32      total_buf_size;       /* total buffer size required   */
    AP_UINT16      num_entries;          /* number of entries            */
    AP_UINT16      total_num_entries;    /* total number of entries      */
    unsigned char  list_options;         /* listing options              */
    unsigned char  reserv3;              /* reserved                      */
    unsigned char  dspu_name[8];         /* Downstream PU name filter    */
    unsigned char  dspu_services;       /* services provided to PU      */
} QUERY_DOWNSTREAM_PU;
```

```
typedef struct downstream_pu_data
{
```

## QUERY\_DOWNSTREAM\_PU

```
AP_UINT16      overlay_size;          /* size of returned entry      */
unsigned char  dspu_name[8];          /* PU name                      */
unsigned char  description[32];      /* resource description         */
unsigned char  reserv1[16];          /* reserved                      */
unsigned char  ls_name[8];           /* Link name                    */
unsigned char  pu_sscp_sess_active;  /* Is the PU-SSCP session active */
unsigned char  dspu_services;        /* DSPU service type           */
SESSION_STATS  pu_sscp_stats;        /* SSCP-PU session statistics   */
unsigned char  reserva[20];          /* reserved                      */
} DOWNSTREAM_PU_DATA;
```

```
typedef struct session_stats
{
AP_UINT16      rcv_ru_size;          /* session receive RU size     */
AP_UINT16      send_ru_size;         /* session send RU size        */
AP_UINT16      max_send_btu_size;    /* maximum send BTU size       */
AP_UINT16      max_rcv_btu_size;     /* maximum rcv BTU size        */
AP_UINT16      max_send_pac_win;     /* maximum send pacing window  */
AP_UINT16      cur_send_pac_win;     /* current send pacing window  */
AP_UINT16      max_rcv_pac_win;     /* maximum receive pacing window */
/* size */
AP_UINT16      cur_rcv_pac_win;      /* current receive pacing window */
/* size */
AP_UINT32      send_data_frames;     /* number of data frames sent  */
AP_UINT32      send_fmd_data_frames; /* num fmd data frames sent    */
AP_UINT32      send_data_bytes;     /* number of data bytes sent   */
AP_UINT32      rcv_data_frames;     /* number of data frames received */
AP_UINT32      rcv_fmd_data_frames; /* num fmd data frames received */
AP_UINT32      rcv_data_bytes;     /* number of data bytes received */
unsigned char  sidh;                /* session ID high byte (from LFSID) */
unsigned char  sidl;                /* session ID low byte (from LFSID) */
unsigned char  odai;                /* ODAI bit set                 */
unsigned char  ls_name[8];          /* Link station name            */
unsigned char  pacing_type;         /* type of pacing in use        */
} SESSION_STATS;
```

## Supplied parameters

The application supplies the following parameters:

### ***opcode***

AP\_QUERY\_DOWNSTREAM\_PU

### ***buf\_ptr***

A pointer to a data buffer that CS/AIX will use to return the requested information.

### ***buf\_size***

Size of the supplied data buffer.

### ***num\_entries***

Maximum number of downstream PUs for which data should be returned. To request data for a specific PU rather than a range, specify the value 1. To return as many entries as possible, specify zero; in this case, CS/AIX will return the maximum number of entries that can be accommodated in the supplied data buffer.

### ***list\_options***

The position in the list from which CS/AIX should begin to return data. Possible values are:

#### **AP\_FIRST\_IN\_LIST**

Start at the first entry in the list.

#### **AP\_LIST\_INCLUSIVE**

Start at the entry specified by the *dspu\_name* parameter.

#### **AP\_LIST\_FROM\_NEXT**

Start at the entry immediately following the entry specified by the *dspu\_name* parameter.

For more information about how the list is ordered and how the application can obtain specific entries from it, see [“List options for QUERY\\_\\* Verbs”](#) on page 33.

### ***dspu\_name***

Name of the PU for which information is required (as specified on DEFINE\_LS), or the name to be used as an index into the list of PUs. This value is ignored if *list\_options* is set to AP\_FIRST\_IN\_LIST. The



name is an 8-byte EBCDIC type-A string, padded on the right with EBCDIC spaces if the name is shorter than 8 characters.

***dspu\_services***

DSPU services filter. Specifies whether to filter the returned information by the type of services provided to the PUs. Possible values are:

**AP\_PU\_CONCENTRATION**

Return information only on downstream PUs served by SNA gateway.

**AP\_DLUR**

Return information only on downstream PUs served by DLUR.

**AP\_NONE**

Return information about all downstream PUs.

## Returned parameters: successful execution

If the verb executes successfully, CS/AIX returns the following parameters:

***primary\_rc***

AP\_OK

***buf\_size***

Length of the information returned in the supplied buffer.

***total\_buf\_size***

Returned value indicating the size of buffer that would have been required to return all the list information requested. A value greater than *buf\_size* indicates that not all the available entries were returned.

***num\_entries***

Number of entries returned in the data buffer.

***total\_num\_entries***

Total number of entries available. A value greater than *num\_entries* indicates that not all the available entries were returned.

Each entry in the data buffer consists of the following parameters:

***downstream\_pu\_data.overlay\_size***

The size of the returned *downstream\_pu\_data* structure, and therefore the offset to the start of the next entry in the data buffer.

When your application needs to go through the returned buffer to find each *downstream\_pu\_data* structure in turn, it must use this value to move to the correct offset for the next data structure, and must not use the C `sizeof()` operator. This is because the size of the returned overlay may increase in future releases of CS/AIX; using the returned overlay size ensures that your application will continue to work with future releases.

***downstream\_pu\_data.dspu\_name***

Name of the downstream PU. The name is an 8-byte EBCDIC type-A string, padded on the right with EBCDIC spaces if the name is shorter than 8 characters.

***downstream\_pu\_data.description***

A null-terminated text string describing the LS to the downstream PU, as specified in the definition of the LS.

***downstream\_pu\_data.ls\_name***

Name of the LS used to access the downstream PU. This is an 8-byte ASCII string, padded on the right with spaces if the name is shorter than 8 characters.

***downstream\_pu\_data.pu\_sscp\_sess\_active***

Specifies whether the PU-SSCP session to the downstream PU is active. Possible values are:

**AP\_YES**

The session is active.

### **AP\_NO**

The session is not active.

### ***downstream\_pu\_data.dspu\_services***

Specifies the type of services provided to the PU.

Possible values are:

### **AP\_PU\_CONCENTRATION**

Downstream PU is served by SNA gateway.

### **AP\_DLUR**

Downstream PU is served by DLUR.

### ***downstream\_pu\_data.pu\_sscp\_stats.rcv\_ru\_size***

Maximum receive RU size; this field is reserved (and set to zero) if the downstream PU is served by SNA gateway.

### ***downstream\_pu\_data.pu\_sscp\_stats.send\_ru\_size***

Maximum send RU size; this field is reserved (and set to zero) if the downstream PU is served by SNA gateway.

### ***downstream\_pu\_data.pu\_sscp\_stats.max\_send\_btu\_size***

Maximum BTU size that can be sent.

### ***downstream\_pu\_data.pu\_sscp\_stats.max\_rcv\_btu\_size***

Maximum BTU size that can be received.

### ***downstream\_pu\_data.pu\_sscp\_stats.max\_send\_pac\_win***

Reserved (always set to zero).

### ***downstream\_pu\_data.pu\_sscp\_stats.cur\_send\_pac\_win***

Reserved (always set to zero).

### ***downstream\_pu\_data.pu\_sscp\_stats.max\_rcv\_pac\_win***

Reserved (always set to zero).

### ***downstream\_pu\_data.pu\_sscp\_stats.cur\_rcv\_pac\_win***

Reserved (always set to zero).

### ***downstream\_pu\_data.pu\_sscp\_stats.send\_data\_frames***

Number of normal flow data frames sent.

### ***downstream\_pu\_data.pu\_sscp\_stats.send\_fmd\_data\_frames***

Number of normal flow FMD data frames sent.

### ***downstream\_pu\_data.pu\_sscp\_stats.send\_data\_bytes***

Number of normal flow data bytes sent.

### ***downstream\_pu\_data.pu\_sscp\_stats.rcv\_data\_frames***

Number of normal flow data frames received.

### ***downstream\_pu\_data.pu\_sscp\_stats.rcv\_fmd\_data\_frames***

Number of normal flow FMD data frames received.

### ***downstream\_pu\_data.pu\_sscp\_stats.rcv\_data\_bytes***

Number of normal flow data bytes received.

### ***downstream\_pu\_data.pu\_sscp\_stats.sidh***

Session ID high byte.

### ***downstream\_pu\_data.pu\_sscp\_stats.sidl***

Session ID low byte.

### ***downstream\_pu\_data.pu\_sscp\_stats.odai***

Origin Destination Assignor Indicator. When bringing up a session, the sender of the BIND sets this field to zero if the local node contains the primary link station, and sets it to one if the BIND sender is the node containing the secondary link station.

### ***downstream\_pu\_data.pu\_sscp\_stats.ls\_name***

Link station name associated with statistics. This is an 8-byte ASCII character string, right-padded with spaces if the name is shorter than 8 characters.

***downstream\_pu\_data.pacing\_type***

The type of receive pacing in use on the PU-SSCP. This parameter will always be set to AP\_NONE.

**Returned parameters: parameter check**

If the verb does not execute because of a parameter error, CS/AIX returns the following parameters:

***primary\_rc***

AP\_PARAMETER\_CHECK

***secondary\_rc***

Possible values are:

**AP\_INVALID\_PU\_NAME**

The *list\_options* parameter was set to AP\_LIST\_INCLUSIVE, to list all entries starting from the supplied name, but the *dspu\_name* parameter was not valid.

**AP\_INVALID\_LIST\_OPTION**

The *list\_options* parameter was not set to a valid value.

Appendix B, “Common return codes,” on page 661 lists further secondary return codes associated with AP\_PARAMETER\_CHECK, which are common to all NOF verbs.

**Returned parameters: function not supported**

If the verb does not execute successfully because the local node configuration does not support it, CS/AIX returns the following parameters:

***primary\_rc*****AP\_FUNCTION\_NOT\_SUPPORTED**

The local node does not support SNA gateway or DLUR; this is defined by the *pu\_conc\_support* and *dlur\_support* parameters on the DEFINE\_NODE verb.

**Returned parameters: other conditions**

Appendix B, “Common return codes,” on page 661 lists further combinations of primary and secondary return codes that are common to all NOF verbs.

**QUERY\_DSPU\_TEMPLATE**

The QUERY\_DSPU\_TEMPLATE verb returns information about defined downstream PU templates used for SNA gateway over implicit links.

This verb can be used to obtain information about a specific downstream PU template, or about a number of downstream PU templates, depending on the options used. To obtain information about a specific downstream PU template or multiple downstream PU templates, set the *template\_name* parameter. The *template\_name* parameter is ignored if the *list\_options* parameter is set to AP\_FIRST\_IN\_LIST.

**VCB structure**

```
typedef struct query_dspu_template
{
    AP_UINT16      opcode;           /* verb operation code          */
    unsigned char  reserv1;         /* reserved                    */
    unsigned char  format;         /* reserved                    */
    AP_UINT16      primary_rc;      /* primary return code          */
    AP_UINT32      secondary_rc;    /* secondary return code        */
    unsigned char  *buf_ptr;        /* pointer to buffer            */
    AP_UINT32      buf_size;        /* buffer size                  */
    AP_UINT32      total_buf_size;  /* total buffer size required   */
    AP_UINT16      num_entries;     /* number of entries            */
    AP_UINT16      total_num_entries; /* total number of entries      */
    unsigned char  list_options;    /* listing options              */
    unsigned char  reserv3;         /* reserved                    */
}
```

## QUERY\_DSPU\_TEMPLATE

```
    unsigned char  template_name[8]; /* name of DSPU template          */
} QUERY_DSPU_TEMPLATE;

typedef struct dspu_template_data
{
    AP_UINT16      overlay_size;      /* size of returned entry          */
    unsigned char  template_name[8]; /* name of DSPU template          */
    unsigned char  description[32];   /* resource description            */
    unsigned char  reserv2[16];       /* reserved                        */
    unsigned char  reserv1[12];       /* reserved                        */
    AP_UINT16      max_instance;      /* max active template instance   */
    AP_UINT16      active_instance;   /* current active instances       */
    unsigned char  num_of_dslu_templates; /* number of DSLU templates    */
} DSPU_TEMPLATE_DATA;
```

Each `dspu_template_data` structure is followed by one or more downstream LU templates; the number of the downstream LU templates is specified by the `number_of_dslu_templates` parameter. Each downstream LU template has the following format:

```
typedef struct dslu_template_data
{
    AP_UINT16      overlay_size;      /* size of this entry            */
    unsigned char  reserv1[2];        /* reserved                      */
    DSLU_TEMPLATE  dslu_template;     /* downstream LU template       */
} DSLU_TEMPLATE_DATA;

typedef struct dslu_template
{
    unsigned char  min_nau;           /* minimum NAU address in range  */
    unsigned char  max_nau;           /* maximum NAU address in range  */
    unsigned char  allow_timeout;     /* allow timeout of host LU?     */
    unsigned char  delayed_logon;     /* allow delayed logon to host LU */
    unsigned char  reserv1[8];        /* reserved                      */
    unsigned char  host_lu[8];        /* host LU or pool name          */
} DSLU_TEMPLATE;
```

## Supplied parameters

The application supplies the following parameters:

### ***opcode***

AP\_QUERY\_DSPU\_TEMPLATE

### ***buf\_ptr***

A pointer to a data buffer that CS/AIX will use to return the requested information.

### ***buf\_size***

Size of the supplied data buffer.

### ***num\_entries***

Maximum number of templates for which data should be returned. To request data for a specific template rather than a range, specify the value 1. To return as many entries as possible, specify zero; in this case, CS/AIX will return the maximum number of entries that can be accommodated in the supplied data buffer.

### ***list\_options***

The position in the list from which CS/AIX should begin to return data. Possible values are:

#### **AP\_FIRST\_IN\_LIST**

Start at the first entry in the list.

#### **AP\_LIST\_INCLUSIVE**

Start at the entry specified by the `template_name` parameter.

#### **AP\_LIST\_FROM\_NEXT**

Start at the entry immediately following the entry specified by the `template_name` parameter.

For more information about how the list is ordered and how the application can obtain specific entries from it, see [“List options for QUERY\\_\\* Verbs”](#) on page 33.

**template\_name**

Name of the DSPU template for which information is required, or the name to be used as an index into the list. This is an 8-byte string in a locally displayable character set. This parameter is ignored if *list\_options* is set to AP\_FIRST\_IN\_LIST.

**Returned parameters: successful execution**

If the verb executes successfully, CS/AIX returns the following parameters:

**primary\_rc**

AP\_OK

**buf\_size**

Length of the information returned in the buffer.

**total\_buf\_size**

Returned value indicating the size of buffer that would have been required to return all the list information requested. This may be higher than *buf\_size*.

**num\_entries**

The number of entries actually returned.

**total\_num\_entries**

Total number of entries that could have been returned. This may be higher than *num\_entries*.

**dspu\_template\_data.overlay\_size**

The number of bytes in this entry, including any downstream LU templates, and the offset to the next entry returned (if any).

When your application needs to go through the returned buffer to find each *dspu\_template\_data* structure in turn, it must use this value to move to the correct offset for the next data structure, and must not use the C `sizeof()` operator. This is because the size of the returned overlay may increase in future releases of CS/AIX; using the returned overlay size ensures that your application will continue to work with future releases.

**dspu\_template\_data.template\_name**

Name of the DSPU template.

**dspu\_template\_data.description**

Resource description, as defined on the DEFINE\_DSPU\_TEMPLATE verb.

**dspu\_template\_data.max\_instance**

The maximum number of instances of the template which can be active simultaneously.

**dspu\_template\_data.active\_instance**

The number of instances of the template which are currently active.

**dspu\_template\_data.num\_of\_dslu\_templates**

Number of downstream LU templates for this downstream PU template. Following this parameter are *num\_of\_dslu\_templates* entries, one for each DSLU template.

**dslu\_template\_data.overlay\_size**

The number of bytes in this entry, and the offset to the next entry returned (if any).

When your application needs to go through the returned buffer to find each *dslu\_template\_data* structure in turn, it must use this value to move to the correct offset for the next data structure, and must not use the C `sizeof()` operator. This is because the size of the returned overlay may increase in future releases of CS/AIX; using the returned overlay size ensures that your application will continue to work with future releases.

**dslu\_template\_data.min\_nau**

Minimum NAU address in the range of DSLU templates.

**dslu\_template\_data.max\_nau**

Maximum NAU address in the range of DSLU templates.

## QUERY\_FOCAL\_POINT

### ***dslu\_template\_data.allow\_timeout***

Indicates whether CS/AIX is allowed to timeout host LUs used by this downstream LU if the session is left inactive for the timeout period specified on the host LU definition. Possible values are:

#### **AP\_YES**

CS/AIX is allowed to timeout host LUs used by this downstream LU.

#### **AP\_NO**

CS/AIX is not allowed to timeout host LUs used by this downstream LU.

This field is ignored if the downstream LUs are used to communicate with a CS/AIX Primary RUI application instead of a host.

### ***dslu\_template\_data.delayed\_logon***

Indicates whether CS/AIX delays connecting the downstream LU to the host LU until the first data is received from the downstream LU. Instead, a simulated logon screen is sent to the downstream LU. Possible values are:

#### **AP\_YES**

CS/AIX delays connecting the downstream LU to the host LU.

#### **AP\_NO**

CS/AIX does not delay connecting the downstream LU to the host LU.

This field is ignored if the downstream LUs are used to communicate with a CS/AIX Primary RUI application instead of a host.

### ***dslu\_template\_data.host\_lu\_name***

Name of the host LU or host LU pool onto which all the downstream LUs within the range will be mapped.

If the downstream LUs are used to communicate with a CS/AIX Primary RUI application instead of a host, this field is set to the string #PRIRUI# in EBCDIC.

## Returned parameters: parameter check

If the verb does not execute because of a parameter error, CS/AIX returns the following parameters:

### ***primary\_rc***

AP\_PARAMETER\_CHECK

### ***secondary\_rc***

#### **AP\_INVALID\_TEMPLATE\_NAME**

The template specified in the *template\_name* parameter was not valid.

Appendix B, “Common return codes,” on page 661 lists further secondary return codes associated with AP\_PARAMETER\_CHECK, which are common to all NOF verbs.

## Returned parameters: other conditions

Appendix B, “Common return codes,” on page 661 lists further combinations of primary and secondary return codes that are common to all NOF verbs.

## QUERY\_FOCAL\_POINT

---

QUERY\_FOCAL\_POINT returns information about the focal point for a specific Management Services category, or about multiple focal points, depending on the options used.

## VCB structure

```
typedef struct query_focal_point
{
    AP_UINT16      opcode;          /* verb operation code      */
    unsigned char  reserv2;        /* reserved                  */
    unsigned char  format;         /* reserved                  */
}
```

```

AP_UINT16      primary_rc;          /* primary return code      */
AP_UINT32      secondary_rc;       /* secondary return code    */
unsigned char  *buf_ptr;           /* pointer to buffer        */
AP_UINT32      buf_size;           /* buffer size              */
AP_UINT32      total_buf_size;     /* total buffer size required */
AP_UINT16      num_entries;        /* number of entries        */
AP_UINT16      total_num_entries;  /* total number of entries  */
unsigned char  list_options;       /* listing options         */
unsigned char  reserv3;            /* reserved                  */
unsigned char  ms_category[8];     /* name of MS category     */
} QUERY_FOCAL_POINT;

```

```

typedef struct fp_data
{
    AP_UINT16      overlay_size;     /* size of returned entry   */
    unsigned char  ms_appl_name[8];  /* focal point application name */
    unsigned char  ms_category[8];  /* focal point category     */
    unsigned char  description[32];  /* resource description     */
    unsigned char  reserv1[16];     /* reserved                  */
    unsigned char  fp_fqcp_name[17]; /* focal point fully qualified
                                     /* cp name                   */
    unsigned char  bkup_appl_name[8]; /* backup focal point
                                     /* application name          */
    unsigned char  bkup_fp_fqcp_name[17]; /* backup fp fully qualified cp
                                     /* name                      */
    unsigned char  implicit_appl_name[8]; /* implicit focal point appl name */
    unsigned char  implicit_fp_fqcp_name[17]; /* implicit fp fully qualified
                                     /* cp name                   */
    unsigned char  fp_type;         /* focal point type         */
    unsigned char  fp_status;       /* focal point status       */
    unsigned char  fp_routing;      /* type of MDS routing to use */
    unsigned char  reserva[20];     /* reserved                  */
    AP_UINT16      number_of_appls; /* number of applications   */
} FP_DATA;

```

Each `fp_data` structure is followed by one or more application names; the number of these is specified by the `number_of_appls` parameter. Each application name has the following format:

```

unsigned char  appl_name[8];       /* application name        */

```

## Supplied parameters

The application supplies the following parameters:

### ***opcode***

AP\_QUERY\_FOCAL\_POINT

### ***buf\_ptr***

A pointer to a data buffer that CS/AIX will use to return the requested information.

### ***buf\_size***

Size of the supplied data buffer.

### ***num\_entries***

Maximum number of entries for which data should be returned. To request data for a specific entry rather than a range, specify the value 1. To return as many entries as possible, specify zero; in this case, CS/AIX will return the maximum number of entries that can be accommodated in the supplied data buffer.

### ***list\_options***

The position in the list of focal points from which CS/AIX should begin to return data. Possible values are:

#### **AP\_FIRST\_IN\_LIST**

Start at the first entry in the list.

#### **AP\_LIST\_INCLUSIVE**

Start at the entry specified by the `ms_category` parameter.

#### **AP\_LIST\_FROM\_NEXT**

Start at the entry immediately following the entry specified by the `ms_category` parameter.

For more information about how the list is ordered and how the application can obtain specific entries from it, see [“List options for QUERY\\_\\* Verbs”](#) on page 33.

***ms\_category***

Management Services category. This parameter is not used if *list\_options* is set to AP\_FIRST\_IN\_LIST.

This may be either one of the category names specified in the MS Discipline-Specific Application Programs table of *Systems Network Architecture: Management Services Reference* (see the Bibliography), padded with EBCDIC spaces (0x40), or a user-defined category. A user-defined category name is an 8-byte type-1134 EBCDIC string, padded with EBCDIC spaces (0x40) if necessary.

**Returned parameters: successful execution**

If the verb executes successfully, CS/AIX returns the following parameters:

***primary\_rc***

AP\_OK

***buf\_size***

Length of the information returned in the supplied buffer.

***total\_buf\_size***

Returned value indicating the size of buffer that would have been required to return all the list information requested. A value greater than *buf\_size* indicates that not all the available entries were returned.

***num\_entries***

Number of entries returned in the data buffer.

***total\_num\_entries***

Total number of entries available. A value greater than *num\_entries* indicates that not all the available entries were returned.

Each entry in the data buffer consists of the following parameters:

***fp\_data.overlay\_size***

The size of the returned *fp\_data* structure, and therefore the offset to the start of the next entry in the data buffer.

When your application needs to go through the returned buffer to find each *fp\_data* structure in turn, it must use this value to move to the correct offset for the next data structure, and must not use the C `sizeof()` operator. This is because the size of the returned overlay may increase in future releases of CS/AIX; using the returned overlay size ensures that your application will continue to work with future releases.

***fp\_data.ms\_appl\_name***

Name of the currently active focal point application. This is either one of the MS Discipline-Specific Application Programs specified in the *Systems Network Architecture: Management Services Reference* (see the Bibliography), or an EBCDIC string, using type-1134 characters, padded on the right with spaces if the name is shorter than 8 characters.

***fp\_data.ms\_category***

Management Services category. This is either one of the category names specified in the *Systems Network Architecture: Management Services Reference* (see the Bibliography), or an EBCDIC string, using type-1134 characters, padded on the right with spaces if the name is shorter than 8 characters.

***fp\_data.description***

A null-terminated text string describing the focal point, as specified in the definition of the focal point.

***fp\_data.fp\_fqcp\_name***

Fully qualified control point name of the currently active focal point. This name is a 17-byte EBCDIC string, padded on the right with EBCDIC spaces. It consists of a network ID of 1-8 A-string characters, an EBCDIC dot (period) character, and a network name of 1-8 A-string characters.



***fp\_data.bkup\_appl\_name***

Backup focal point application name. This is either one of the MS Discipline-Specific Application Programs specified in the *Systems Network Architecture: Management Services Reference* (see the Bibliography), or an EBCDIC string, using type-1134 characters, padded on the right with spaces if the name is shorter than 8 characters.

***fp\_data.bkup\_fp\_fqcp\_name***

Fully qualified control point name of the backup focal point. This name is a 17-byte EBCDIC string, padded on the right with EBCDIC spaces. It consists of a network ID of 1-8 A-string characters, an EBCDIC dot (period) character, and a network name of 1-8 A-string characters.

***fp\_data.implicit\_appl\_name***

Name of the implicit focal point application (specified using DEFINE\_FOCAL\_POINT). This is either one of the MS Discipline-Specific Application Programs specified in the *Systems Network Architecture: Management Services Reference* (see the Bibliography), or an EBCDIC string, using type-1134 characters, padded on the right with spaces if the name is shorter than 8 characters.

***fp\_data.implicit\_fp\_fqcp\_name***

Fully qualified control point name of the implicit focal point (specified using DEFINE\_FOCAL\_POINT). This name is a 17-byte EBCDIC string, padded on the right with EBCDIC spaces. It consists of a network ID of 1-8 A-string characters, an EBCDIC dot (period) character, and a network name of 1-8 A-string characters.

***fp\_data.fp\_type***

Type of focal point. Refer to the *IBM Systems Network Architecture: Management Services Reference* (see the Bibliography) for further detail. This is one of the following:

AP\_EXPLICIT\_PRIMARY\_FP

AP\_IMPLICIT\_PRIMARY\_FP

AP\_BACKUP\_FP

AP\_DEFAULT\_PRIMARY\_FP

AP\_DOMAIN\_FP

AP\_HOST\_FP

AP\_NO\_FP

***fp\_data.fp\_status***

Status of the focal point. This is one of the following:

**AP\_ACTIVE**

The focal point is currently active.

**AP\_NOT\_ACTIVE**

The focal point is currently not active.

**AP\_PENDING**

The focal point is pending active. This occurs after an implicit request has been sent to the focal point and before the response has been received.

**AP\_NEVER\_ACTIVE**

No focal point information is available for the specified category although application registrations for the category have been accepted.

***fp\_data.fp\_routing***

Specifies whether applications should use default or direct routing to route traffic to the focal point. This is one of the following:

**AP\_DEFAULT**

The MDS\_MU should be delivered to the focal point using default routing.

**AP\_DIRECT**

The MDS\_MU should be routed on a session directly to the focal point.

## QUERY\_GLOBAL\_LOG\_TYPE

### ***fp\_data.number\_of\_appls***

Number of applications registered for this focal point category.

### ***appl\_name***

Name of application registered for focal point category. This is either one of the MS Discipline-Specific Application Programs specified in the *Systems Network Architecture: Management Services Reference* (see the Bibliography), or an EBCDIC string, using type-1134 characters, padded on the right with spaces if the name is shorter than 8 characters.

## Returned parameters: parameter check

If the verb does not execute because of a parameter error, CS/AIX returns the following parameters:

### ***primary\_rc***

AP\_PARAMETER\_CHECK

### ***secondary\_rc***

Possible values are:

#### **AP\_INVALID\_MS\_CATEGORY**

The *list\_options* parameter was set to AP\_LIST\_INCLUSIVE, to list all entries starting from the supplied name, but the *ms\_category* parameter was not valid.

#### **AP\_INVALID\_LIST\_OPTION**

The *list\_options* parameter was not set to a valid value.

Appendix B, “Common return codes,” on page 661 lists further secondary return codes associated with AP\_PARAMETER\_CHECK, which are common to all NOF verbs.

## Returned parameters: function not supported

If the verb does not execute successfully because the local node configuration does not support it, CS/AIX returns the following parameters:

### ***primary\_rc***

#### **AP\_FUNCTION\_NOT\_SUPPORTED**

The local node does not support MS network management functions; this is defined by the *mds\_supported* parameter on the DEFINE\_NODE verb.

## Returned parameters: other conditions

Appendix B, “Common return codes,” on page 661 lists further combinations of primary and secondary return codes that are common to all NOF verbs.

## QUERY\_GLOBAL\_LOG\_TYPE

---

This verb allows a NOF application to determine the types of information that CS/AIX records in log files. It specifies default values that are used on all servers (unless they are overridden on a particular server by SET\_LOG\_TYPE); QUERY\_LOG\_TYPE can be used to determine the values being used on a particular server.

CS/AIX logs messages for the following types of event:

### **Problem**

An abnormal event that degrades the system in a way perceptible to a user (such as abnormal termination of a session).

### **Exception**

An abnormal event that may degrade the system but that is not immediately perceptible to a user (such as receiving a message that is not valid from the remote system).

### **Audit**

A normal event (such as starting a session).

Problem and exception messages are logged to the error log file; audit messages are logged to the audit log file. Problem messages are always logged and cannot be disabled, but you can specify whether to log each of the other two message types. For each of the two files (audit and error), you can specify whether to use succinct logging (including only the text of the message and a summary of the message source) or full logging (including full details of the message source, cause, and any action required).

This verb must be issued to the node currently acting as the central logger; for more information, see [“CONNECT\\_NODE”](#) on page 51.

## VCB structure

```
typedef struct query_global_log_type
{
    AP_UINT16      opcode;           /* verb operation code          */
    unsigned char  reserv2;         /* reserved                     */
    unsigned char  format;         /* reserved                     */
    AP_UINT16      primary_rc;      /* primary return code          */
    AP_UINT32      secondary_rc;    /* secondary return code        */
    unsigned char  audit;          /* audit logging on or off      */
    unsigned char  exception;      /* exception logging on or off  */
    unsigned char  succinct_audits; /* use succinct logging in audit file? */
    unsigned char  succinct_errors; /* use succinct logging in error file? */
    unsigned char  reserv3[4];     /* reserved                     */
} QUERY_GLOBAL_LOG_TYPE;
```

## Supplied parameters

The application supplies the following parameter:

### *opcode*

AP\_QUERY\_GLOBAL\_LOG\_TYPE

## Returned parameters: successful execution

If the verb executes successfully, CS/AIX returns the following parameters:

### *primary\_rc*

AP\_OK

### *secondary\_rc*

Not used.

### *audit*

This parameter indicates whether audit messages are recorded. Possible values are:

#### **AP\_YES**

Audit messages are recorded.

#### **AP\_NO**

Audit messages are not recorded.

### *exception*

This parameter indicates whether exception messages are recorded. Possible values are:

#### **AP\_YES**

Exception messages are recorded.

#### **AP\_NO**

Exception messages are not recorded.

### *succinct\_audits*

This parameter indicates whether succinct logging or full logging is used in the audit log file. Possible values are:

#### **AP\_YES**

Succinct logging: each message in the log file contains a summary of the message header information (such as the message number, log type, and system name) and the message text

## QUERY\_ISR\_SESSION

string and parameters. To obtain more details of the cause of the log and any action required, you can use the `snahelp` utility.

### AP\_NO

Full logging: each message in the log file includes a full listing of the message header information, the message text string and parameters, and additional information about the cause of the log and any action required.

If you are using central logging, the choice of succinct or full logging for messages from all computers is determined by the setting of this parameter on the server acting as the central logger; this setting may either be from the `SET_GLOBAL_LOG_TYPE` verb, or from a `SET_LOG_TYPE` verb issued to that server to override the default.

### *succinct\_errors*

This parameter indicates whether succinct logging or full logging is used in the error log file; this applies to both exception logs and problem logs. The possible values and their meanings are the same as for the *succinct\_audits* parameter.

## Returned parameters: parameter check

If the verb does not execute because of a parameter error, CS/AIX returns the following parameters:

### *primary\_rc*

AP\_PARAMETER\_CHECK

### *secondary\_rc*

AP\_NOT\_CENTRAL\_LOGGER

The verb was issued to a node that is not the central logger.

## Returned parameters: other conditions

Appendix B, “Common return codes,” on page 661 lists further combinations of primary and secondary return codes that are common to all NOF verbs.

## QUERY\_ISR\_SESSION

QUERY\_ISR\_SESSION returns list information about the sessions for which a network node is providing intermediate session routing.

This verb can be used to obtain information about a specific session, or about a number of sessions, depending on the options used. It can be used only if the CS/AIX node is a network node, and is not valid if it is an end node or LEN node.

This list is ordered by *fqpcid.pcid* first and then by EBCDIC lexicographical ordering on *fqpcid.fqcp\_name*. The format of the *fqpcid* structure is an 8-byte PCID (Procedure Correlator Identifier) and the network qualified CP name of the session originator.

This verb must be issued to a running node.

## VCB structure

```
typedef struct query_isr_session
{
    AP_UINT16      opcode;                /* verb operation code          */
    unsigned char  reserv2;               /* reserved                     */
    unsigned char  format;                /* reserved                     */
    AP_UINT16      primary_rc;            /* primary return code          */
    AP_UINT32      secondary_rc;          /* secondary return code        */
    unsigned char  *buf_ptr;              /* pointer to buffer            */
    AP_UINT32      buf_size;              /* buffer size                  */
    AP_UINT32      total_buf_size;        /* total buffer size required   */
    AP_UINT16      num_entries;           /* number of entries            */
    AP_UINT16      total_num_entries;     /* total number of entries      */
    unsigned char  list_options;          /* listing options              */
    unsigned char  session_type;          /* is this query for DLUR or regular */
                                          /*   ISR sessions?              */
}
```

```

    FQPCID      fqpcid;          /* fully qualified procedure */
                                /* correlator ID                */
} QUERY_ISR_SESSION;

typedef struct isr_session_summary
{
    AP_UINT16    overlay_size;   /* size of returned entry      */
    FQPCID      fqpcid;         /* fully qualified procedure    */
                                /* correlator ID                */
} ISR_SESSION_SUMMARY;

```

```

typedef struct isr_session_detail
{
    AP_UINT16    overlay_size;   /* size of returned entry      */
    AP_UINT16    sub_overlay_size; /* offset to appended RSCV     */
    FQPCID      fqpcid;         /* fully qualified procedure    */
                                /* correlator ID                */
    unsigned char trans_pri;     /* Transmission priority:      */
    unsigned char cos_name[8];   /* Class of Service name       */
    unsigned char ltd_res;       /* Session spans a limited resource */
    unsigned char reserv1[2];    /* reserved                     */
    EXTENDED_SESSION_STATS pri_ext_sess_stats; /* primary hop session stats */
    EXTENDED_SESSION_STATS sec_ext_sess_stats; /* secondary hop session stats */
    unsigned char sess_lu_type;  /* session LU type             */
    unsigned char sess_lu_level; /* session LU level            */
    unsigned char pri_tg_number; /* Primary session TG number    */
    unsigned char sec_tg_number; /* Secondary session TG number  */
    AP_UINT32    rtp_tcid;       /* RTP TC identifier           */
    AP_UINT32    time_active;     /* time elapsed since activation */
    unsigned char isr_state;     /* current state of ISR session */
    unsigned char reserv2[11];   /* reserved                     */
    unsigned char mode_name[8];  /* mode name                   */
    unsigned char pri_lu_name[17]; /* primary LU name             */
    unsigned char sec_lu_name[17]; /* secondary LU name           */
    unsigned char pri_adj_cp_name[17]; /* primary stage adjacent CP name */
    unsigned char sec_adj_cp_name[17]; /* secondary stage adjacent CP name */
    unsigned char reserv3[3];    /* reserved                     */
    unsigned char rscv_len;      /* length of following RSCV     */
} ISR_SESSION_DETAIL;

```

The ISR session detail structure may be followed by a Route Selection Control Vector (RSCV) as defined by SNA Formats. This control vector defines the session route through the network and is carried on the BIND. This RSCV is included only if the node's configuration (specified using DEFINE\_NODE) indicates that RSCVs should be stored for ISR sessions.

```

typedef struct fqpcid
{
    unsigned char pcid[8];       /* procedure correlator identifier */
    unsigned char fqcp_name[17]; /* originator's network qualified */
                                /* CP name                        */
    unsigned char reserve3[3];   /* reserved                       */
} FQPCID;

```

```

typedef struct extended_session_stats
{
    AP_UINT16    rcv_ru_size;     /* session receive RU size      */
    AP_UINT16    send_ru_size;    /* session send RU size         */
    AP_UINT16    max_send_btu_size; /* maximum send BTU size       */
    AP_UINT16    max_rcv_btu_size; /* maximum rcv BTU size        */
    AP_UINT16    max_send_pac_win; /* maximum send pacing window size */
    AP_UINT16    cur_send_pac_win; /* current send pacing window size */
    AP_UINT16    send_rpc;        /* send residual pacing count   */
    AP_UINT16    max_rcv_pac_win; /* maximum rcv pacing window size */
    AP_UINT16    cur_rcv_pac_win; /* current rcv pacing window size */
    AP_UINT16    rcv_rpc;        /* receive residual pacing count */
    AP_UINT32    send_data_frames; /* number of data frames sent   */
    AP_UINT32    send_fmd_data_frames; /* num fmd data frames sent */
    AP_UINT32    send_data_bytes; /* number of data bytes sent    */
    AP_UINT32    send_fmd_data_bytes; /* number of fmd data bytes sent */
    AP_UINT32    rcv_data_frames; /* number of data frames received */
    AP_UINT32    rcv_fmd_data_frames; /* num fmd data frames received */
    AP_UINT32    rcv_data_bytes; /* number of data bytes received */
    AP_UINT32    rcv_fmd_data_bytes; /* number of fmd data bytes received */
    unsigned char sidh;          /* session ID high byte (from LFSID) */
    unsigned char sidl;          /* session ID low byte (from LFSID) */
    unsigned char odai;          /* ODAI bit set                 */
}

```

## QUERY\_ISR\_SESSION

```
    unsigned char  ls_name[8];           /* link station name          */
    unsigned char  pacing_type;         /* type of pacing in use     */
    unsigned char  reserv1[100];       /* reserved                   */
} EXTENDED_SESSION_STATS;
```

### Supplied parameters

The application supplies the following parameters:

#### **opcode**

AP\_QUERY\_ISR\_SESSION

#### **buf\_ptr**

A pointer to a data buffer that CS/AIX will use to return the requested information.

#### **buf\_size**

Size of the supplied data buffer.

#### **num\_entries**

Maximum number of sessions for which data should be returned. To request data for a specific session rather than a range, specify the value 1. To return as many entries as possible, specify zero; in this case, CS/AIX will return the maximum number of entries that can be accommodated in the supplied data buffer.

#### **list\_options**

The position in the list from which CS/AIX should begin to return data, and the level of information required for each entry. Specify the level of information with one of the following values:

##### **AP\_SUMMARY**

Summary information only.

##### **AP\_DETAIL**

Detailed information.

Combine this value using a logical OR operation with one of the following values:

##### **AP\_FIRST\_IN\_LIST**

Start at the first entry in the list.

##### **AP\_LIST\_INCLUSIVE**

Start at the entry specified by the *pcid* and *fqcp\_name* parameters.

##### **AP\_LIST\_FROM\_NEXT**

Start at the entry immediately following the entry specified by the *pcid* and *fqcp\_name* parameters.

The list is ordered by *pcid* (numerically), and then by *fqcp\_name*. For more information about how the application can obtain specific entries from the list, see [“List options for QUERY\\_\\* Verbs” on page 33](#).

#### **session\_type**

Specifies whether DLUR-maintained sessions or regular ISR sessions are being queried. Possible values are:

##### **AP\_DLUR\_SESSIONS**

DLUR-maintained sessions are being queried.

##### **AP\_ISR\_SESSIONS**

Regular ISR sessions are being queried.

#### **fqpcid.pcid**

Procedure Correlator ID. This is an 8-byte hexadecimal string. This value is ignored if *list\_options* is set to AP\_FIRST\_IN\_LIST.

#### **fqpcid.fqcp\_name**

Fully qualified control point name of the session for which information is required, or the name to be used as an index into the list of sessions. This value is ignored if *list\_options* is set to AP\_FIRST\_IN\_LIST.

The name is a 17-byte EBCDIC string, right-padded with EBCDIC spaces. It consists of a network ID of up to 8 A-string characters, an EBCDIC dot (period) character, and a network name of up to 8 A-string characters.

## Returned parameters: successful execution

If the verb executes successfully, CS/AIX returns the following parameters:

### ***primary\_rc***

AP\_OK

### ***buf\_size***

Length of the information returned in the supplied buffer.

### ***total\_buf\_size***

Returned value indicating the size of buffer that would have been required to return all the list information requested. A value greater than *buf\_size* indicates that not all the available entries were returned.

### ***num\_entries***

Number of entries returned in the data buffer.

### ***total\_num\_entries***

Total number of entries available. A value greater than *num\_entries* indicates that not all the available entries were returned.

Each entry in the data buffer consists of the following parameters:

### ***isr\_session\_summary.overlay\_size***

The size of the returned *isr\_session\_summary* structure, and therefore the offset to the start of the next entry in the data buffer.

When your application needs to go through the returned buffer to find each *isr\_session\_summary* structure in turn, it must use this value to move to the correct offset for the next data structure, and must not use the C `sizeof()` operator. This is because the size of the returned overlay may increase in future releases of CS/AIX; using the returned overlay size ensures that your application will continue to work with future releases.

### ***isr\_session\_summary.fqpcid.pcid***

Procedure Correlator ID.

### ***isr\_session\_summary.fqpcid.fqcp\_name***

Fully qualified CP name. The name is a 17-byte EBCDIC string, right-padded with EBCDIC spaces. It consists of a network ID of up to 8 A-string characters, an EBCDIC dot (period) character, and a network name of up to 8 A-string characters.

### ***isr\_session\_detail.overlay\_size***

The size of the returned *isr\_session\_detail* structure, and therefore the offset to the start of the next entry in the data buffer.

When your application needs to go through the returned buffer to find each *isr\_session\_detail* structure in turn, it must use this value to move to the correct offset for the next data structure, and must not use the C `sizeof()` operator. This is because the size of the returned overlay may increase in future releases of CS/AIX; using the returned overlay size ensures that your application will continue to work with future releases.

### ***isr\_session\_detail.fqpcid.pcid***

Procedure Correlator ID.

### ***isr\_session\_detail.fqpcid.fqcp\_name***

Fully qualified CP name. The name is a 17-byte EBCDIC string, right-padded with EBCDIC spaces. It consists of a network ID of up to 8 A-string characters, an EBCDIC dot (period) character, and a network name of up to 8 A-string characters.

### ***isr\_session\_detail.trans\_pri***

Transmission priority. This parameter has one of the following values:

## QUERY\_ISR\_SESSION

- AP\_LOW AP\_MEDIUM
- AP\_HIGH AP\_NETWORK

### ***isr\_session\_detail.cos\_name***

Class of service name. This is an 8-byte alphanumeric type-A EBCDIC string (starting with a letter), padded on the right with EBCDIC spaces.

### ***isr\_session\_detail.ltd\_res***

Specifies whether the session uses a limited resource link. Possible values are:

#### **AP\_YES**

Session uses a limited resource link.

#### **AP\_NO**

Session does not use a limited resource link.

For each of the two sessions (primary and secondary), the `extended_session_stats` structure contains the following fields, each preceded by `isr_session_detail.pri_ext_sess_stats.*_*` for the primary session and `isr_session_detail.sec_ext_sess_stats.*_*` for the secondary session:

### ***rcv\_ru\_size***

Maximum receive RU size.

### ***send\_ru\_size***

Maximum send RU size.

### ***max\_send\_btu\_size***

Maximum BTU size that can be sent.

### ***max\_rcv\_btu\_size***

Maximum BTU size that can be received.

### ***max\_send\_pac\_win***

Maximum size of the send pacing window.

### ***cur\_send\_pac\_win***

Current size of the send pacing window.

### ***send\_rpc***

Send residual pacing count.

### ***max\_rcv\_pac\_win***

Maximum size of the receive pacing window.

### ***cur\_rcv\_pac\_win***

Current size of the receive pacing window.

### ***rcv\_rpc***

Receive residual pacing count.

### ***send\_data\_frames***

Number of normal flow data frames sent.

### ***send\_fmd\_data\_frames***

Number of normal flow FMD data frames sent.

### ***send\_data\_bytes***

Number of normal flow data bytes sent.

### ***send\_fmd\_data\_bytes***

Number of normal flow FMD data bytes sent.

### ***rcv\_data\_frames***

Number of normal flow data frames received.

### ***rcv\_fmd\_data\_frames***

Number of normal flow FMD data frames received.

### ***rcv\_data\_bytes***

Number of normal flow data bytes received.



***rcv\_fmd\_data\_bytes***

Number of normal flow FMD data bytes received.

***sidh***

Session ID high byte.

***sidl***

Session ID low byte.

***odai***

Origin Destination Assignor Indicator. When bringing up a session, the sender of the BIND sets this field to zero if the local node contains the primary link station, and sets it to one if the BIND sender is the node containing the secondary link station.

***ls\_name***

Link station name or name of the RTP connection associated with statistics. This is an 8-byte string in a locally displayable character set. All 8 bytes are significant. This field can be used to correlate the intermediate session statistics with a particular link station.

 ***pacing\_type***

Receive pacing type in use on the session. Possible values are:

- AP\_NONE
- AP\_PACING\_FIXED
- AP\_PACING\_ADAPTIVE

The following parameters are also returned (these parameters are not part of the `session_stats` structure):

***isr\_session.detail.sess\_lu\_type***

The LU type of the session specified on the BIND. Possible values are (LU type 5 is intentionally omitted):

- AP\_LU\_TYPE\_0
- AP\_LU\_TYPE\_1
- AP\_LU\_TYPE\_2
- AP\_LU\_TYPE\_3
- AP\_LU\_TYPE\_4
- AP\_LU\_TYPE\_6
- AP\_LU\_TYPE\_7
- AP\_LU\_TYPE\_UNKNOWN

***isr\_session.detail.sess\_lu\_level***

The LU level of the session. Possible values are:

- AP\_LU\_LEVEL\_0
- AP\_LU\_LEVEL\_1
- AP\_LU\_LEVEL\_2
- AP\_LU\_LEVEL\_UNKNOWN

For LU types other than 6, this parameter is set to `AP_LU_LEVEL_0`. The value `AP_LU_LEVEL_UNKNOWN` is always returned unless collection of names has been enabled using `DEFINE_ISR_STATS`.

***isr\_session.detail.pri\_tg\_number***

The TG number associated with the link traversed by the primary session hop. If the primary session stage traverses an RTP connection, zero is returned. The value zero is always returned unless collection of names has been enabled using `DEFINE_ISR_STATS`.

***isr\_session.detail.sec\_tg\_number***

The TG number associated with the link traversed by the secondary session hop. If the secondary session stage traverses an RTP connection, zero is returned. The value zero is always returned unless collection of names has been enabled using DEFINE\_ISR\_STATS.

***isr\_session.detail.rtp\_tcid***

Total TC ID for the RTP connection. This is returned in cases where this ISR session forms part of an ANR/ISR boundary. In other cases, this parameter is set to zero. The value zero is always returned unless collection of names has been enabled using DEFINE\_ISR\_STATS.

***isr\_session.detail.time\_active***

The elapsed time since the activation of the session, in hundredths of a second. The value zero is always returned unless collection of names has been enabled using DEFINE\_ISR\_STATS.

***isr\_session.detail.isr\_state***

The current state of the session. Possible values are:

- AP\_ISR\_INACTIVE
- AP\_ISR\_PENDING\_ACTIVE
- AP\_ISR\_ACTIVE
- AP\_ISR\_PENDING\_INACTIVE

***isr\_session.detail.mode\_name***

The mode name for the session. This is an 8-byte alphanumeric type-A EBCDIC string starting with a letter, padded on the right with EBCDIC spaces. All binary zeros are returned unless collection of names has been enabled using DEFINE\_ISR\_STATS.

***isr\_session.detail.pri\_lu\_name***

The primary LU name of the session. This name is a 17-byte EBCDIC string, padded on the right with EBCDIC spaces. The name consists of a network ID of 1-8 A-string characters, an EBCDIC dot (period) character, and an LU name of 1-8 A-string characters. If this name is not available, all binary zeros are returned in this field. All binary zeros are always returned unless collection of names has been enabled using DEFINE\_ISR\_STATS.

***isr\_session.detail.sec\_lu\_name***

The secondary LU name of the session. This name is a 17-byte EBCDIC string, padded on the right with EBCDIC spaces. The name consists of a network ID of 1-8 A-string characters, an EBCDIC dot (period) character, and an LU name of 1-8 A-string characters. If this name is not available, all binary zeros are returned in this field. All binary zeros are always returned unless collection of names has been enabled using DEFINE\_ISR\_STATS.

***isr\_session.detail.pri\_adj\_cp\_name***

The primary stage adjacent CP name of this session. If the primary session traverses an RTP connection, the CP name of the remote RTP endpoint is returned. This name is a 17-byte EBCDIC string, padded on the right with EBCDIC spaces. The name consists of a network ID of 1-8 A-string characters, an EBCDIC dot (period) character, and a CP name of 1-8 A-string characters. If this name is not available, all binary zeros are returned in this field. All binary zeros are always returned unless collection of names has been enabled using DEFINE\_ISR\_STATS.

***isr\_session.detail.sec\_adj\_cp\_name***

The secondary stage adjacent CP name of this session. If the secondary session traverses an RTP connection, the CP name of the remote RTP endpoint is returned. This name is a 17-byte EBCDIC string, padded on the right with EBCDIC spaces. The name consists of a network ID of 1-8 A-string characters, an EBCDIC dot (period) character, and a CP name of 1-8 A-string characters. If this name is not available, all binary zeros are returned in this field. All binary zeros are always returned unless collection of names has been enabled using DEFINE\_ISR\_STATS.

***isr\_session\_detail.rscv\_len***

Length of the RSCV which is appended to the `session_detail` structure. (If none is appended, then the length is zero.)

## Returned parameters: parameter check

If the verb does not execute because of a parameter error, CS/AIX returns the following parameters:

### *primary\_rc*

AP\_PARAMETER\_CHECK

### *secondary\_rc*

Possible values are:

#### **AP\_INVALID\_FQPCID**

The *list\_options* parameter was set to AP\_LIST\_INCLUSIVE to list all entries starting from the supplied name, but the *pcid* parameter was not valid.

#### **AP\_INVALID\_LIST\_OPTION**

The *list\_options* parameter was not set to a valid value.

Appendix B, “Common return codes,” on page 661 lists further secondary return codes associated with AP\_PARAMETER\_CHECK, which are common to all NOF verbs.

## Returned parameters: function not supported

If the verb does not execute successfully because the local node is not a network node, CS/AIX returns the following parameters:

### *primary\_rc*

#### **AP\_INVALID\_VERB**

The local node is not a network node. This verb can be used only at a network node.

## Returned parameters: other conditions

Appendix B, “Common return codes,” on page 661 lists further combinations of primary and secondary return codes that are common to all NOF verbs.

## QUERY\_KERNEL\_MEMORY\_LIMIT

This verb returns information about the amount of kernel memory that CS/AIX is currently using, the maximum amount it has used, and the configured limit. This allows you to check memory usage and set the limit appropriately, to ensure that sufficient memory is available for CS/AIX components and for other programs on the AIX computer.

You can specify the kernel memory limit when starting the CS/AIX software (for more information, see the *IBM Communications Server for Data Center Deployment on AIX Administration Guide*), or modify it later when the node is running (using the SET\_KERNEL\_MEMORY\_LIMIT verb).

## VCB structure

```
typedef struct query_kernel_memory_limit
{
    AP_UINT16      opcode;           /* verb operation code          */
    unsigned char  reserv2;         /* reserved                    */
    unsigned char  format;         /* reserved                    */
    AP_UINT16      primary_rc;      /* primary return code         */
    AP_UINT32      secondary_rc;    /* secondary return code       */
    AP_UINT32      limit;          /* kernel memory limit, 0 => no limit */
    AP_UINT32      actual;         /* current amount of memory allocated */
    AP_UINT32      max_used;       /* maximum amount of memory allocated */
    unsigned char  reset_max_used; /* set max_used = actual       */
    unsigned char  reserv3[8];     /* Reserved                    */
} QUERY_KERNEL_MEMORY_LIMIT;
```

## Supplied parameters

The application supplies the following parameters:

## QUERY\_LOCAL\_LU

### ***opcode***

AP\_QUERY\_KERNEL\_MEMORY\_LIMIT

### ***reset\_max\_used***

Specify whether CS/AIX should reset the *max\_used* value (after returning it on this verb) to match the amount of memory currently allocated. This ensures that a subsequent QUERY\_KERNEL\_MEMORY\_LIMIT verb will return the maximum amount used since this verb, rather than the maximum amount used since the system was started (or since the *max\_used* value was last reset). Possible values are:

#### **AP\_YES**

Reset the *max\_used* value to match the current memory allocation.

#### **AP\_NO**

Do not reset the *max\_used* value.

## Returned parameters: successful execution

If the verb executes successfully, CS/AIX returns the following parameters:

### ***primary\_rc***

AP\_OK

### ***secondary\_rc***

Not used.

### ***limit***

The maximum amount of kernel memory, in bytes, that CS/AIX is permitted to use at any time. If a CS/AIX component attempts to allocate kernel memory that would take the total amount of memory currently allocated to CS/AIX components above this limit, the allocation attempt will fail. A value of zero indicates no limit.

### ***actual***

The amount of kernel memory, in bytes, currently allocated to CS/AIX components.

### ***max\_used***

The maximum amount of kernel memory, in bytes, that has been allocated to CS/AIX components at any time since the *max\_used* parameter was last reset (as described for *reset\_max\_used* above), or since the CS/AIX software was started.

### ***reset\_max\_used***

Specifies whether CS/AIX resets the *max\_used* value (after returning it on this command) to match the amount of memory currently allocated. This ensures that a subsequent QUERY\_KERNEL\_MEMORY\_LIMIT verb will return the maximum amount used since this command was issued, rather than the maximum amount used since the system was started (or since the *max\_used* value was last reset). Possible values are:

#### **AP\_YES**

CS/AIX resets the *max\_used* value to match the current memory allocation.

#### **AP\_NO**

CS/AIX does not reset the *max\_used* value.

## Returned parameters: other conditions

Appendix B, “Common return codes,” on page 661 lists further combinations of primary and secondary return codes that are common to all NOF verbs.

## QUERY\_LOCAL\_LU

---

QUERY\_LOCAL\_LU returns information about local LUs.

This verb can be used to obtain either summary or detailed information, about a specific LU or about multiple LUs, depending on the options used. It can also obtain information about the LU associated with the CP (the default LU).

## VCB structure

```

typedef struct query_local_lu
{
    AP_UINT16      opcode;          /* verb operation code          */
    unsigned char  reserv2;         /* reserved                     */
    unsigned char  format;         /* reserved                     */
    AP_UINT16      primary_rc;     /* primary return code         */
    AP_UINT32      secondary_rc;   /* secondary return code       */
    unsigned char  *buf_ptr;       /* pointer to buffer           */
    AP_UINT32      buf_size;       /* buffer size                 */
    AP_UINT32      total_buf_size; /* total buffer size required  */
    AP_UINT16      num_entries;    /* number of entries           */
    AP_UINT16      total_num_entries; /* total number of entries    */
    unsigned char  list_options;   /* listing options             */
    unsigned char  reserv3;        /* reserved                     */
    unsigned char  lu_name[8];     /* LU name                     */
    unsigned char  lu_alias[8];   /* LU alias                    */
    unsigned char  pu_name[8];    /* PU name filter              */
} QUERY_LOCAL_LU;

```

```

typedef struct local_lu_summary
{
    AP_UINT16      overlay_size;    /* size of returned entry      */
    unsigned char  lu_name[8];     /* LU name                    */
    unsigned char  lu_alias[8];    /* LU alias                   */
    unsigned char  description[32]; /* resource description        */
    unsigned char  reserv1[16];    /* reserved                    */
} LOCAL_LU_SUMMARY;

```

```

typedef struct local_lu_detail
{
    AP_UINT16      overlay_size;    /* size of returned entry      */
    unsigned char  lu_name[8];     /* LU name                    */
    LOCAL_LU_DEF_DATA def_data;    /* defined data                */
    LOCAL_LU_DET_DATA det_data;    /* determined data            */
} LOCAL_LU_DETAIL;

```

```

typedef struct local_lu_def_data
{
    unsigned char  description[32]; /* resource description        */
    unsigned char  reserv1;        /* reserved                    */
    unsigned char  security_list_name[14]; /* security access list name */
    unsigned char  reserv3;        /* reserved                    */
    unsigned char  lu_alias[8];    /* local LU alias             */
    unsigned char  nau_address;    /* NAU address                */
    unsigned char  syncpt_support; /* is Syncpoint supported?    */
    AP_UINT16      lu_session_limit; /* LU session limit          */
    unsigned char  default_pool;   /* is LU in the pool of default */
    /* LUs?                          */
    unsigned char  reserv2;        /* reserved                    */
    unsigned char  pu_name[8];     /* PU name                    */
    unsigned char  lu_attributes; /* LU attributes              */
    unsigned char  sscp_id[6];    /* SSCP ID                    */
    unsigned char  disable;       /* disable or enable local LU */
    ROUTING_DATA  attach_routing_data; /* routing data for incoming */
    /* attaches                          */
    unsigned char  reserv6;        /* reserved                    */
    unsigned char  reserv4[7];     /* reserved                    */
    unsigned char  reserv5[16];    /* reserved                    */
} LOCAL_LU_DEF_DATA;

```

```

typedef struct local_lu_det_data
{
    unsigned char  lu_sscp_sess_active; /* Is LU-SSCP session active */
    unsigned char  appl_conn_active;   /* reserved                   */
    unsigned char  reserv1[2];         /* reserved                   */
    SESSION_STATS lu_sscp_stats;      /* LU-SSCP session statistics */
    unsigned char  sscp_id[6];        /* SSCP ID                    */
} LOCAL_LU_DET_DATA;

```

```

typedef struct session_stats
{
    AP_UINT16      rcv_ru_size;     /* session receive RU size    */
    AP_UINT16      send_ru_size;    /* session send Ru size       */
}

```

## QUERY\_LOCAL\_LU

```
AP_UINT16      max_send_btu_size;    /* max send BTU size          */
AP_UINT16      max_rcv_btu_size;    /* max rcv BTU size           */
AP_UINT16      max_send_pac_win;    /* max send pacing window size*/
AP_UINT16      cur_send_pac_win;    /* current send pacing win size*/
AP_UINT16      max_rcv_pac_win;    /* max receive pacing win size*/
AP_UINT16      cur_rcv_pac_win;    /* current receive pacing      */
/* window size                */
AP_UINT32      send_data_frames;    /* number of data frames sent  */
AP_UINT32      send_fmd_data_frames; /* num of fmd data frames sent */
AP_UINT32      send_data_bytes;    /* number of data bytes sent   */
AP_UINT32      rcv_data_frames;    /* num data frames received    */
AP_UINT32      rcv_fmd_data_frames; /* num of fmd data frames recvd*/
AP_UINT32      rcv_data_bytes;    /* number of data bytes received*/
unsigned char  sidh;                /* session ID high byte        */
unsigned char  sidl;                /* session ID low byte         */
unsigned char  odai;                /* ODAI bit set                */
unsigned char  ls_name;              /* link station name           */
unsigned char  pacing_type;         /* type of pacing in use       */
} SESSION_STATS;
```

```
typedef struct routing_data
{
  unsigned char sys_name[128];      /* Name of target system for TP */
  AP_INT32      timeout;            /* timeout value in seconds     */
  unsigned char back_level;         /* reserved                      */
  unsigned char reserved[59];      /* reserved                      */
} ROUTING_DATA;
```

## Supplied parameters

The application supplies the following parameters:

### ***opcode***

AP\_QUERY\_LOCAL\_LU

### ***buf\_ptr***

A pointer to a data buffer that CS/AIX will use to return the requested information.

### ***buf\_size***

Size of the supplied data buffer.

### ***num\_entries***

Maximum number of LUs for which data should be returned. To request data for a specific LU rather than a range, specify the value 1. To return as many entries as possible, specify zero; in this case, CS/AIX will return the maximum number of entries that can be accommodated in the supplied data buffer.

### ***list\_options***

The position in the list from which CS/AIX should begin to return data, and the level of information required for each entry. Specify the level of information with one of the following values:

#### **AP\_SUMMARY**

Summary information only.

#### **AP\_DETAIL**

Detailed information.

Combine this value using a logical OR operation with one of the following values:

#### **AP\_FIRST\_IN\_LIST**

Start at the first entry in the list.

#### **AP\_LIST\_INCLUSIVE**

Start at the entry specified by the *lu\_name* or *lu\_alias* parameter.

#### **AP\_LIST\_FROM\_NEXT**

Start at the entry immediately following the entry specified by the *lu\_name* or *lu\_alias* parameter.

If AP\_FIRST\_IN\_LIST is specified, you can also include the following option, using a logical OR operation:

**AP\_LIST\_BY\_ALIAS**

The list is returned in order of LU alias rather than LU name. This option is only valid if AP\_FIRST\_IN\_LIST is also specified. (For AP\_LIST\_FROM\_NEXT or AP\_LIST\_INCLUSIVE, the list is in order of LU alias or LU name, depending on which was specified as the index into the list.)

For more information about how the application can obtain specific entries from the list, see “List options for QUERY\_\* Verbs” on page 33. The list is in EBCDIC lexicographical order (irrespective of the length of each name).

**lu\_name**

Fully qualified name of the LU for which information is required, or the name to be used as an index into the list of LUs. This value is ignored if *list\_options* is set to AP\_FIRST\_IN\_LIST. To identify the LU by its alias instead of its name, set this parameter to 8 binary zeros, and specify the alias in the *lu\_alias* parameter; to identify the default LU, set both *lu\_name* and *lu\_alias* to 8 binary zeros.

The name is an 8-byte EBCDIC string, padded on the right with EBCDIC spaces if the name is shorter than 8 characters.

**lu\_alias**

LU alias of the LU for which information is required, or the name to be used as an index into the list of LUs. This value is ignored if *list\_options* is set to AP\_FIRST\_IN\_LIST.

This is an 8-byte ASCII string, padded on the right with spaces if the name is shorter than 8 characters. To identify the LU by its LU name instead of its alias, set this parameter to 8 binary zeros, and specify the name in the *lu\_name* parameter; to identify the default LU, set both *lu\_name* and *lu\_alias* to 8 binary zeros.

**pu\_name**

PU name filter. To return information only on LUs associated with a specific PU, specify the PU name; to return information without filtering on PU name, set this parameter to 8 binary zeros.

The name is an 8-byte type-A EBCDIC string (starting with a letter), padded on the right with EBCDIC spaces.

**Returned parameters: successful execution**

If the verb executes successfully, CS/AIX returns the following parameters:

**primary\_rc**

AP\_OK

**buf\_size**

Length of the information returned in the supplied buffer.

**total\_buf\_size**

Returned value indicating the size of buffer that would have been required to return all the list information requested. A value greater than *buf\_size* indicates that not all the available entries were returned.

**num\_entries**

Number of entries returned in the data buffer.

**total\_num\_entries**

Total number of entries available. A value greater than *num\_entries* indicates that not all the available entries were returned.

Each entry in the data buffer consists of the following parameters:

**local\_lu\_summary.overlay\_size**

The size of the returned `local_lu_summary` structure, and therefore the offset to the start of the next entry in the data buffer.

When your application needs to go through the returned buffer to find each `local_lu_summary` structure in turn, it must use this value to move to the correct offset for the next data structure, and must not use the C `sizeof()` operator. This is because the size of the returned overlay may increase

in future releases of CS/AIX; using the returned overlay size ensures that your application will continue to work with future releases.

***local\_lu\_summary.lu\_name***

LU name. This name is an 8-byte type-A EBCDIC character string.

***local\_lu\_summary.lu\_alias***

LU alias. This is an 8-byte ASCII character string.

***local\_lu\_summary.description***

A null-terminated text string describing the local LU, as specified in the definition of the LU.

***local\_lu\_detail.overlay\_size***

The size of the returned `local_lu_detail` structure, and therefore the offset to the start of the next entry in the data buffer.

When your application needs to go through the returned buffer to find each `local_lu_detail` structure in turn, it must use this value to move to the correct offset for the next data structure, and must not use the C `sizeof()` operator. This is because the size of the returned overlay may increase in future releases of CS/AIX; using the returned overlay size ensures that your application will continue to work with future releases.

***local\_lu\_detail.lu\_name***

LU name. This name is an 8-byte type-A EBCDIC character string.

***local\_lu\_detail.def\_data.description***

A null-terminated text string describing the local LU, as specified in the definition of the LU.

***local\_lu\_detail.def\_data.security\_list\_name***

Name of the security access list used by this local LU (defined using the `DEFINE_SECURITY_ACCESS_LIST` verb). If this parameter is set to 14 binary zeros, the LU is available for use by any user.

***local\_lu\_detail.def\_data.lu\_alias***

LU alias. This is an 8-byte ASCII character string.

***local\_lu\_detail.def\_data.nau\_address***

Network accessible unit address of the LU. This is in the range 1-255 if the LU is a dependent LU, or zero if the LU is an independent LU.

***local\_lu\_detail.def\_data.syncpt\_support***

Specifies whether the LU supports Syncpoint functions. Possible values are:

**AP\_YES**

Syncpoint is supported.

**AP\_NO**

Syncpoint is not supported.

***local\_lu\_detail.def\_data.lu\_session\_limit***

Maximum total number of sessions (across all modes) for the local LU. A value of zero indicates that there is no limit.

***local\_lu\_detail.def\_data.default\_pool***

Specifies whether the LU is in the pool of default dependent LUs. When an application attempts to start a conversation without specifying a local LU name, CS/AIX will select an unused LU from this pool. Possible values are:

**AP\_YES**

The LU is in the pool of default LUs, and can be used by applications that do not specify an LU name.

**AP\_NO**

The LU is not in the pool.

If the LU is an independent LU, this parameter is reserved.



***local\_lu\_detail.def\_data.pu\_name***

For dependent LUs, this parameter identifies the PU that this LU will use. This is an 8-byte type-A EBCDIC string (starting with a letter), padded on the right with EBCDIC spaces if necessary. For independent LUs, this field is not used; it is set to 8 binary zeros.

***local\_lu\_detail.def\_data.lu\_attributes***

Configured LU attributes. Possible values are:

**AP\_NONE**

No additional information identified.

**AP\_DISABLE\_PWSUB**

Disable password substitution support for the local LU. Password substitution means that passwords are encrypted before transmission between the local and remote LUs, rather than being sent as clear text. CS/AIX normally uses password substitution if the remote system supports it.

This value is provided as a work-around for communications with some remote systems that do not implement password substitution correctly. If you use this option, you should be aware that this involves sending and receiving passwords in clear text (which may represent a security risk). The option should not be set unless there are problems with the remote system's implementation of password substitution.

***local\_lu\_detail.def\_data.sscp\_id***

Specifies the ID of the SSCP permitted to activate this LU. It is a 6-byte binary field. This parameter is used only by dependent LUs, and is set to all binary zeros for independent LUs or if the LU can be activated by any SSCP.

***local\_lu\_detail.def\_data.attach\_routing\_data.sys\_name***

The name of the target computer for incoming Allocate requests (requests from a partner TP to start an APPC or CPI-C conversation) that arrive at this local LU. This identifies the computer where the target TP runs.

If this parameter is set to binary zeros, CS/AIX routes the incoming Allocate request dynamically to a running copy of the TP, if available, or attempts to start the TP on the same computer as the local LU.

***local\_lu\_detail.def\_data.attach\_routing\_data.timeout***

The timeout value (in seconds) for dynamic load requests. A request will time out if the invoked TP has not issued a Receive\_Allocate verb (APPC), or Accept\_Conversation or Accept\_Incoming (CPI-C), within this time. A value of -1 indicates no timeout (dynamic load requests will wait indefinitely).

The following parameters are used only for dependent LUs. For independent LUs, they are reserved (set to binary zeros); you can obtain the equivalent information by issuing the QUERY\_SESSION verb for the appropriate session between this LU and the partner LU.

***local\_lu\_detail.det\_data.lu\_sscp\_session\_active***

Specifies whether the LU-SSCP session is active. Possible values are:

**AP\_YES**

The LU-SSCP session is active.

**AP\_NO**

The LU-SSCP session is not active.

***local\_lu\_detail.det\_data.lu\_sscp\_stats***

Statistics for the LU-SSCP session.

***local\_lu\_detail.det\_data.lu\_sscp\_stats.rcv\_ru\_size***

This parameter is always reserved.

***local\_lu\_detail.det\_data.lu\_sscp\_stats.send\_ru\_size***

This parameter is always reserved.

***local\_lu\_detail.det\_data.lu\_sscp\_stats.max\_send\_btu\_size***

Maximum basic transmission unit (BTU) size that can be sent.

***local\_lu\_detail.det\_data.lu\_sscp\_stats.max\_rcv\_btu\_size***

Maximum BTU size that can be received.

***local\_lu\_detail.det\_data.lu\_sscp\_stats.max\_send\_pac\_win***

This parameter is always set to zero.

***local\_lu\_detail.det\_data.lu\_sscp\_stats.cur\_send\_pac\_win***

This parameter is always set to zero.

***local\_lu\_detail.det\_data.lu\_sscp\_stats.max\_rcv\_pac\_win***

This parameter is always set to zero.

***local\_lu\_detail.det\_data.lu\_sscp\_stats.cur\_rcv\_pac\_win***

This parameter is always set to zero.

***local\_lu\_detail.det\_data.lu\_sscp\_stats.send\_data\_frames***

Number of normal flow data frames sent

***local\_lu\_detail.det\_data.lu\_sscp\_stats.send\_fmd\_data\_frames***

Number of normal flow function management data (FMD) frames sent.

***local\_lu\_detail.det\_data.lu\_sscp\_stats.send\_data\_bytes***

Number of normal flow data bytes sent.

***local\_lu\_detail.det\_data.lu\_sscp\_stats.rcv\_data\_frames***

Number of normal flow data frames received.

***local\_lu\_detail.det\_data.lu\_sscp\_stats.rcv\_fmd\_data\_frames***

Number of normal flow FMD data frames received.

***local\_lu\_detail.det\_data.lu\_sscp\_stats.rcv\_data\_bytes***

Number of normal flow data bytes received.

***local\_lu\_detail.det\_data.lu\_sscp\_stats.sidh***

Session ID high byte.

***local\_lu\_detail.det\_data.lu\_sscp\_stats.sidl***

Session ID low byte.

***local\_lu\_detail.det\_data.lu\_sscp\_stats.odai***

Origin Destination Assignor Indicator. When bringing up a session, the sender of the ACTLU sets this parameter to zero if the local node contains the primary link station, and sets it to one if the ACTLU sender is the node containing the secondary link station.

***local\_lu\_detail.det\_data.lu\_sscp\_stats.ls\_name***

Link station name associated with the statistics This is an 8-byte string in a locally displayable character set. All eight bytes are significant. This parameter can be used to correlate this session with the link over which the session flows.

***local\_lu\_detail.det\_data.lu\_sscp\_stats.pacing\_type***

Receive pacing type in use on the LU-SSCP session. This parameter is set to AP\_NONE.

***local\_lu\_detail.det\_data.sscp\_id***

This parameter is a 6-byte field containing the SSCP ID received in the ACTPU for the PU used by this LU.

This parameter is reserved if *lu\_sscp\_sess\_active* is not set to AP\_YES.

## Returned parameters: parameter check

If the verb does not execute because of a parameter error, CS/AIX returns the following parameters:

***primary\_rc***

AP\_PARAMETER\_CHECK

***secondary\_rc***

Possible values are:

**AP\_INVALID\_LU\_ALIAS**

The *list\_options* parameter was set to AP\_LIST\_INCLUSIVE to list all entries starting from the supplied name, but the *lu\_alias* parameter was not valid.

**AP\_INVALID\_LU\_NAME**

The *list\_options* parameter was set to AP\_LIST\_INCLUSIVE to list all entries starting from the supplied name, but the *lu\_name* parameter was not valid.

**AP\_INVALID\_LIST\_OPTION**

The *list\_options* parameter was not set to a valid value.

Appendix B, “Common return codes,” on page 661 lists further secondary return codes associated with AP\_PARAMETER\_CHECK, which are common to all NOF verbs.

**Returned parameters: other conditions**

Appendix B, “Common return codes,” on page 661 lists further combinations of primary and secondary return codes that are common to all NOF verbs.

**QUERY\_LOCAL\_TOPOLOGY**

All APPN nodes maintain a local topology database which holds information about the TGs to all adjacent nodes. QUERY\_LOCAL\_TOPOLOGY allows information about these TGs to be returned.

This verb can be used to obtain either summary or detailed information, about a specific TG or about multiple TGs, depending on the options used.

This verb must be issued to a running node.

**VCB structure**

```
typedef struct query_local_topology
{
    AP_UINT16          opcode;                /* verb operation code          */
    unsigned char     reserv2;                /* reserved                      */
    unsigned char     format;                 /* reserved                      */
    AP_UINT16          primary_rc;            /* primary return code          */
    AP_UINT32          secondary_rc;          /* secondary return code        */
    unsigned char     *buf_ptr;               /* pointer to buffer            */
    AP_UINT32          buf_size;              /* buffer size                  */
    AP_UINT32          total_buf_size;        /* total buffer size required   */
    AP_UINT16          num_entries;           /* number of entries            */
    AP_UINT16          total_num_entries;     /* total number of entries      */
    unsigned char     list_options;          /* listing options              */
    unsigned char     reserv3;                /* reserved                      */
    unsigned char     dest[17];              /* TG destination node          */
    unsigned char     dest_type;             /* TG destination node type     */
    unsigned char     tg_num;                /* TG number                    */
} QUERY_LOCAL_TOPOLOGY;
```

```
typedef struct local_topology_summary
{
    AP_UINT16          overlay_size;          /* size of returned entry       */
    unsigned char     dest[17];              /* TG destination node          */
    unsigned char     dest_type;             /* TG destination node type     */
    unsigned char     tg_num;                /* TG number                    */
} LOCAL_TOPOLOGY_SUMMARY;
```

```
typedef struct local_topology_detail
{
    AP_UINT16          overlay_size;          /* size of returned entry       */
    unsigned char     dest[17];              /* TG destination node          */
    unsigned char     dest_type;             /* TG destination node type     */
    unsigned char     tg_num;                /* TG number                    */
    unsigned char     reserv1;                /* reserved                      */
    LINK_ADDRESS      dlc_data;               /* DLC signalling data          */
    AP_UINT32          rs_n;                  /* resource sequence number     */
    unsigned char     status;                 /* tg status                    */
    TG_DEFINED_CHARS  tg_chars;               /* TG characteristics           */
    unsigned char     cp_cp_session_active;  /* CP-CP sessions active?      */
    unsigned char     branch_link_type;      /* Up or down link?            */
    unsigned char     branch_tg;             /* Branch TG?                   */
    unsigned char     appended_data_format;  /* Format of appended data      */
    unsigned char     appended_data_len;     /* Length of appended data     */
}
```

## QUERY\_LOCAL\_TOPOLOGY

```
    unsigned char    reserva[11];          /* reserved          */
} LOCAL_TOPOLOGY_DETAIL;

typedef struct link_address
{
    unsigned char    format;              /* type of link address */
    unsigned char    reserve1;           /* reserved             */
    AP_UINT16        length;             /* length               */
    unsigned char    address[32];        /* address               */
} LINK_ADDRESS;
```

For details of the TG\_DEFINED\_CHARS structure, see [“DEFINE\\_LS” on page 100](#).

If the *list\_options* parameter specifies detailed information, a TG Descriptor CV may be appended to the returned information. See the descriptions of the parameters *local\_topology\_detail.appended\_data\_format* and *local\_topology\_detail.appended\_data\_len* for more information.

## Supplied parameters

The application supplies the following parameters:

### ***opcode***

AP\_QUERY\_LOCAL\_TOPOLOGY

### ***buf\_ptr***

A pointer to a data buffer that CS/AIX will use to return the requested information.

### ***buf\_size***

Size of the supplied data buffer.

### ***num\_entries***

Maximum number of entries for which data should be returned. To request a specific entry rather than a range, specify the value 1. To return as many entries as possible, specify zero; in this case, CS/AIX will return the maximum number of entries that can be accommodated in the supplied data buffer.

### ***list\_options***

The position in the list from which CS/AIX should begin to return data, and the level of information required for each entry. Specify the level of information with one of the following values:

#### **AP\_SUMMARY**

Summary information only.

#### **AP\_DETAIL**

Detailed information.

Combine this value using a logical OR operation with one of the following values:

#### **AP\_FIRST\_IN\_LIST**

Start at the first entry in the list.

#### **AP\_LIST\_INCLUSIVE**

Start at the entry specified by the combination of the *dest*, *dest\_type*, and *tg\_num* parameters.

#### **AP\_LIST\_FROM\_NEXT**

Start at the entry immediately following the entry specified by the combination of the *dest*, *dest\_type*, and *tg\_num* parameters.

The list is ordered by *dest*, then by *dest\_type* (in the order AP\_NETWORK\_NODE, AP\_END\_NODE, AP\_VRN), and lastly in numerical order of *tg\_num*. For more information about how the list is ordered and how the application can obtain specific entries from it, see [“List options for QUERY\\_\\* Verbs” on page 33](#).

### ***dest***

Fully qualified destination node name of the TG for which information is required, or the name to be used as an index into the list of TGs. This value is ignored if *list\_options* is set to AP\_FIRST\_IN\_LIST.

The name is a 17-byte EBCDIC string, right-padded with EBCDIC spaces. It consists of a network ID of up to 8 A-string characters, an EBCDIC dot (period) character, and a network name of up to 8 A-string characters.

***dest\_type***

Node type of the destination node for this TG. This value is ignored if *list\_options* is set to AP\_FIRST\_IN\_LIST. Possible values are:

**AP\_NETWORK\_NODE**

Network node.

**AP\_VRN**

Virtual routing node.

**AP\_END\_NODE**

End node or LEN node.

**AP\_LEARN\_NODE**

Unknown node type.

***tg\_num***

Number associated with the TG. This value is ignored if *list\_options* is set to AP\_FIRST\_IN\_LIST.

## Returned parameters: successful execution

If the verb executes successfully, CS/AIX returns the following parameters:

***primary\_rc***

AP\_OK

***buf\_size***

Length of the information returned in the supplied buffer.

***total\_buf\_size***

Returned value indicating the size of buffer that would have been required to return all the list information requested. A value greater than *buf\_size* indicates that not all the available entries were returned.

***num\_entries***

Number of entries returned in the data buffer.

***total\_num\_entries***

Total number of entries available. A value greater than *num\_entries* indicates that not all the available entries were returned.

Each entry in the data buffer consists of the following parameters:

***local\_topology\_summary.overlay\_size***

The size of the returned *local\_topology\_summary* structure, and therefore the offset to the start of the next entry in the data buffer.

When your application needs to go through the returned buffer to find each *local\_topology\_summary* structure in turn, it must use this value to move to the correct offset for the next data structure, and must not use the C `sizeof()` operator. This is because the size of the returned overlay may increase in future releases of CS/AIX; using the returned overlay size ensures that your application will continue to work with future releases.

***local\_topology\_summary.dest***

Fully qualified destination node name of the TG. The name is a 17-byte EBCDIC string, padded on the right with EBCDIC spaces. It consists of a network ID of 1-8 A-string characters, an EBCDIC dot (period) character, and a network name of 1-8 A-string characters.

***local\_topology\_summary.dest\_type***

Node type of the destination node for this TG. This is one of the following:

**AP\_NETWORK\_NODE**

Network node.

## QUERY\_LOCAL\_TOPOLOGY

### **AP\_VRN**

Virtual routing node.

### **AP\_END\_NODE**

End node or LEN node.

### ***local\_topology\_summary.tg\_num***

Number associated with the TG.

### ***local\_topology\_detail.overlay\_size***

The size of the returned `local_topology_detail` structure, and therefore the offset to the start of the next entry in the data buffer.

When your application needs to go through the returned buffer to find each `local_topology_detail` structure in turn, it must use this value to move to the correct offset for the next data structure, and must not use the C `sizeof()` operator. This is because the size of the returned overlay may increase in future releases of CS/AIX; using the returned overlay size ensures that your application will continue to work with future releases.

### ***local\_topology\_detail.dest***

Fully qualified destination node name of the TG. The name is a 17-byte EBCDIC string, padded on the right with EBCDIC spaces. It consists of a network ID of 1-8 A-string characters, an EBCDIC dot (period) character, and a network name of 1-8 A-string characters.

### ***local\_topology\_detail.dest\_type***

Node type of the destination node for this TG. This is one of the following:

#### **AP\_NETWORK\_NODE**

Network node.

#### **AP\_VRN**

Virtual routing node.

#### **AP\_END\_NODE**

End node or LEN node.

### ***local\_topology\_detail.tg\_num***

Number associated with the TG.

### ***local\_topology\_detail.dlc\_data.length***

If *dest\_type* is `AP_VRN`, this field specifies the length of the DLC address of the connection to the VRN. Otherwise, this field is not used and is set to zero.

### ***local\_topology\_detail.dlc\_data.address***

If *dest\_type* is `AP_VRN`, this field specifies the DLC address (in hexadecimal) of the connection to the VRN. The number of bytes in the address is given by the preceding field, *length*; the remaining bytes in the field are undefined. Otherwise, this field is not used.

For Token Ring or Ethernet, the address is in two parts: a 6-byte MAC address and a 1-byte local SAP address. The bit ordering of the MAC address may not be in the expected format; for information about converting between the two address formats, see [“Bit ordering in MAC addresses” on page 125](#).

### ***local\_topology\_detail.rsn***

Resource Sequence Number. This is assigned by the network node that owns this resource.

### ***local\_topology\_detail.status***

Specifies the status of the TG. This may be one or more of the following, combined by a logical OR operation.

`AP_TG_OPERATIVE`

`AP_TG_CP_CP_SESSIONS`

`AP_TG QUIESCING`

`AP_TG_HPR`

`AP_TG_RTP`

***local\_topology\_detail.tg\_chars***

TG characteristics. For more information about these parameters, see “[DEFINE\\_LS](#)” on page 100.

***local\_topology\_detail.cp\_cp\_session\_active***

Specifies whether the owning node's contention winner CP-CP session is active. Possible values are:

**AP\_YES**

The CP-CP session is active.

**AP\_NO**

The CP-CP session is not active.

**AP\_UNKNOWN**

The CP-CP session status is unknown.

***local\_topology\_detail.branch\_link\_type***

This parameter applies only if the node is a Branch Network Node; it is reserved otherwise.

Specifies the branch link type of this TG. Possible values are:

**AP\_UPLINK**

The TG is an uplink.

**AP\_DOWNLINK**

The TG is a downlink to an End Node.

**AP\_DOWNLINK\_TO\_BRNN**

The TG is a downlink to a Branch Network Node that appears as an End Node from the perspective of the local node.

**AP\_OTHERLINK**

The TG is a link to a VRN.

***local\_topology\_detail.branch\_tg***

This parameter applies only if the node is a Network Node; it is reserved otherwise.

Specifies whether the TG is a branch TG. Possible values are:

**AP\_YES**

The TG is a branch TG.

**AP\_NO**

The TG is not a branch TG.

**AP\_UNKNOWN**

The TG type is unknown.

***local\_topology\_detail.appended\_data\_format***

Specifies the format of data appended to this NOF VCB structure.

If the parameter *local\_topology\_detail.appended\_data\_len* is set to a non-zero value, indicating that appended data is included, this parameter is set to the following value:

**AP\_TG\_DESCRIPTOR\_CV**

The appended data contains a TG Descriptor CV, as defined by SNA Formats.

If *local\_topology\_detail.appended\_data\_len* is zero, indicating that no appended data is included, this parameter is reserved.

***local\_topology\_detail.appended\_data\_len***

Specifies the length of the TG Descriptor CV data appended to this NOF VCB structure. If this parameter is set to zero, no appended data is included.

## Returned parameters: parameter check

If the verb does not execute because of a parameter error, CS/AIX returns the following parameters:

***primary\_rc***

AP\_PARAMETER\_CHECK

## QUERY\_LOG\_FILE

### *secondary\_rc*

Possible values are:

#### **AP\_INVALID\_TG**

The *list\_options* parameter was set to AP\_LIST\_INCLUSIVE to list all entries starting from the supplied name, but the *tg\_num* parameter was not valid.

#### **AP\_INVALID\_LIST\_OPTION**

The *list\_options* parameter was not set to a valid value.

Appendix B, “Common return codes,” on page 661 lists further secondary return codes associated with AP\_PARAMETER\_CHECK, which are common to all NOF verbs.

## Returned parameters: other conditions

Appendix B, “Common return codes,” on page 661 lists further combinations of primary and secondary return codes that are common to all NOF verbs.

## QUERY\_LOG\_FILE

This verb allows the application to determine the name of the file that CS/AIX uses to record audit, error, or usage log messages, the name of the backup log file, and the file size at which log information is copied to the backup file.

## VCB structure

```
typedef struct query_log_file
{
    AP_UINT16      opcode;           /* verb operation code */
    unsigned char  reserv2;         /* reserved */
    unsigned char  format;         /* reserved */
    AP_UINT16      primary_rc;     /* primary return code */
    AP_UINT32      secondary_rc;   /* secondary return code */
    unsigned char  log_file_type;  /* type of log file */
    unsigned char  file_name[81];  /* file name */
    unsigned char  backup_file_name[81]; /* backup file name */
    AP_UINT32      file_size;     /* log file size */
    unsigned char  succinct;      /* reserved */
    unsigned char  reserv3[3];    /* reserved */
} QUERY_LOG_FILE;
```

## Supplied parameters

### *opcode*

AP\_QUERY\_LOG\_FILE

### *log\_file\_type*

The type of log file being queried. Possible values are:

#### **AP\_AUDIT\_FILE**

Audit log file (audit messages only).

#### **AP\_ERROR\_FILE**

Error log file (problem and exception messages).

#### **AP\_USAGE\_FILE**

Usage log file (information on current and peak usage of CS/AIX resources).

## Returned parameters: successful execution

If the verb executes successfully, CS/AIX returns the following parameters:

### *primary\_rc*

AP\_OK



**secondary\_rc**

Not used.

**file\_name**

Name of the log file. This parameter is an ASCII string of 1-80 characters, followed by a null (0x00) character.

If no path is included, the file is stored in the default directory for diagnostics files, /var/sna; if a path is included, this is either a full path (starting with a / character) or the path relative to the default directory.

**backup\_file\_name**

Name of the backup log file. This parameter is an ASCII string of 1-80 characters, followed by a null (0x00) character.

When the log file reaches the size specified by *file\_size* below, CS/AIX copies the current contents of the log file to this file and then clears the log file. You can also request a backup at any time using the SET\_LOG\_FILE verb.

If no path is included, the file is stored in the default directory for diagnostics files, /var/sna; if a path is included, this is either a full path (starting with a / character) or the path relative to the default directory.

**file\_size**

The maximum size of the log file specified by *log\_file\_type*. When a message written to the file causes the file size to exceed this limit, CS/AIX clears the backup log file, copies the current contents of the log file to the backup log file, and then clears the log file. This means that the maximum amount of disk space taken up by log files is approximately twice the value of *file\_size*.

## Returned parameters: parameter check

If the verb does not execute because of a parameter error, CS/AIX returns the following parameters:

**primary\_rc**

AP\_PARAMETER\_CHECK

**secondary\_rc****AP\_INVALID\_FILE\_TYPE**

The *log\_file\_type* parameter was not set to a valid value.

Appendix B, “Common return codes,” on page 661 lists further secondary return codes associated with AP\_PARAMETER\_CHECK, which are common to all NOF verbs.

## Returned parameters: other conditions

Appendix B, “Common return codes,” on page 661 lists further combinations of primary and secondary return codes that are common to all NOF verbs.

## QUERY\_LOG\_TYPE

---

This verb allows a NOF application to determine the types of information that CS/AIX records in log files on a particular server, and whether these are the default settings specified on SET\_GLOBAL\_LOG\_TYPE or local settings specified by a previous SET\_LOG\_TYPE verb.

CS/AIX logs messages for the following types of event:

**Problem**

An abnormal event that degrades the system in a way perceptible to a user (such as abnormal termination of a session).

**Exception**

An abnormal event that may degrade the system but that is not immediately perceptible to a user (such as receiving a message that is not valid from the remote system).

## QUERY\_LOG\_TYPE

### Audit

A normal event (such as starting a session).

Problem and exception messages are logged to the error log file; audit messages are logged to the audit log file. Problem messages are always logged and cannot be disabled, but you can specify whether to log each of the other two message types. For each of the two files (audit and error), you can specify whether to use succinct logging (including only the text of the message and a summary of the message source) or full logging (including full details of the message source, cause, and any action required).

## VCB structure

```
typedef struct query_log_type
{
    AP_UINT16      opcode;           /* verb operation code          */
    unsigned char  reserv2;         /* reserved                    */
    unsigned char  format;         /* reserved                    */
    AP_UINT16      primary_rc;      /* primary return code         */
    AP_UINT32      secondary_rc;    /* secondary return code       */
    unsigned char  override;       /* overriding global settings? */
    unsigned char  audit;          /* audit logging on or off     */
    unsigned char  exception;      /* exception logging on or off */
    unsigned char  succinct_audits; /* use succinct logging in audit file? */
    unsigned char  succinct_errors; /* use succinct logging in error file? */
    unsigned char  reserv3[3];     /* reserved                    */
} QUERY_LOG_TYPE;
```

## Supplied parameters

The application supplies the following parameter:

### *opcode*

AP\_QUERY\_LOG\_TYPE

## Returned parameters: successful execution

If the verb executes successfully, CS/AIX returns the following parameters:

### *primary\_rc*

AP\_OK

### *secondary\_rc*

Not used.

### *override*

Specifies whether the log types and succinct or full logging options returned on this verb are the global log types specified on SET\_GLOBAL\_LOG\_TYPE, or local values specified on SET\_LOG\_TYPE. Possible values are:

#### **AP\_YES**

The *audit*, *exception*, and *succinct\_\** parameters returned are local settings overriding the global settings.

#### **AP\_NO**

The *audit*, *exception*, and *succinct\_\** parameters returned are the global settings, which are not being overridden.

### *audit*

This parameter indicates whether audit messages are recorded. Possible values are:

#### **AP\_YES**

Audit messages are recorded.

#### **AP\_NO**

Audit messages are not recorded.

### *exception*

This parameter indicates whether exception messages are recorded. Possible values are:

**AP\_YES**

Exception messages are recorded.

**AP\_NO**

Exception messages are not recorded.

***succinct\_audits***

This parameter indicates whether succinct logging or full logging is used in the audit log file. Possible values are:

**AP\_YES**

Succinct logging: each message in the log file contains a summary of the message header information (such as the message number, log type, and system name) and the message text string and parameters. To obtain more details of the cause of the log and any action required, you can use the `snahe1p` utility.

**AP\_NO**

Full logging: each message in the log file includes a full listing of the message header information, the message text string and parameters, and additional information about the cause of the log and any action required.

If you are using central logging, the choice of succinct or full logging for messages from all computers is determined by the setting of this parameter on the server acting as the central logger; this setting may either be from the `SET_GLOBAL_LOG_TYPE` verb, or from a `SET_LOG_TYPE` verb issued to that server to override the default.

***succinct\_errors***

This parameter indicates whether succinct logging or full logging is used in the error log file; this applies to both exception logs and problem logs. The possible values and their meanings are the same as for the *succinct\_audits* parameter.

**Returned parameters: other conditions**

Appendix B, “Common return codes,” on page 661 lists further combinations of primary and secondary return codes that are common to all NOF verbs.

**QUERY\_LS**

QUERY\_LS returns a list of information about the link stations defined at the node. This information is structured as "determined data" (data gathered dynamically during execution, returned only if the node is active) and "defined data" (data supplied on DEFINE\_LS).

This verb can be used to obtain either summary or detailed information, about a specific LS or about multiple LSs, depending on the options used.

**VCB structure**

```
typedef struct query_ls
{
    AP_UINT16      opcode;                /* verb operation code          */
    unsigned char  reserv2;               /* reserved                     */
    unsigned char  format;               /* reserved                     */
    AP_UINT16      primary_rc;           /* Primary return code         */
    AP_UINT32      secondary_rc;        /* Secondary return code       */
    unsigned char  *buf_ptr;             /* pointer to buffer           */
    AP_UINT32      buf_size;             /* buffer size                 */
    AP_UINT32      total_buf_size;      /* total buffer size required  */
    AP_UINT16      num_entries;          /* number of entries           */
    AP_UINT16      total_num_entries;    /* total number of entries     */
    unsigned char  list_options;        /* listing options             */
    unsigned char  reserv3;             /* reserved                     */
    unsigned char  ls_name[8];          /* name of link station        */
    unsigned char  port_name[8];        /* port used by link station    */
} QUERY_LS;
```

```
typedef struct ls_summary
{
    AP_UINT16      overlay_size;          /* size of returned entry      */
    unsigned char  ls_name[8];           /* link station name           */
    unsigned char  description[32];      /* resource description        */
    unsigned char  reserv1[16];         /* reserved                    */
    unsigned char  dlc_type;             /* DLC type                   */
    unsigned char  state;                /* link station state         */
    AP_UINT16      act_sess_count;       /* currently active sessions   */
                                           /* count                      */
    unsigned char  det_adj_cp_name[17];  /* determined adjacent CP name */
    unsigned char  det_adj_cp_type;     /* determined adjacent node type */
    unsigned char  port_name[8];        /* port name                  */
    unsigned char  adj_cp_name[17];     /* adjacent CP name          */
    unsigned char  adj_cp_type;         /* adjacent node type        */
} LS_SUMMARY;
```

```
typedef struct ls_detail
{
    AP_UINT16      overlay_size;          /* size of returned entry      */
    unsigned char  ls_name[8];           /* link station name           */
    LS_DET_DATA    det_data;             /* determined data            */
    LS_DEF_DATA    def_data;            /* defined data                */
} LS_DETAIL;
```

```
typedef struct ls_det_data
{
    AP_UINT16      act_sess_count;       /* currently active sessions   */
                                           /* count                      */
    unsigned char  dlc_type;             /* DLC type                   */
    unsigned char  state;                /* link station state         */
    unsigned char  sub_state;            /* link station sub state     */
    unsigned char  det_adj_cp_name[17];  /* adjacent CP name          */
    unsigned char  det_adj_cp_type;     /* adjacent node type        */
    unsigned char  dlc_name[8];         /* name of DLC                */
    unsigned char  dynamic;              /* specifies whether LS is    */
                                           /* dynamic                    */
    unsigned char  migration;            /* supports migration partners */
    unsigned char  tg_num;               /* TG number                  */
    LS_STATS       ls_stats;             /* link station statistics    */
    AP_UINT32      start_time;           /* time LS started           */
    AP_UINT32      stop_time;           /* time LS stopped           */
    AP_UINT32      up_time;              /* total time LS active       */
    AP_UINT32      current_state_time;   /* time in current state     */
    unsigned char  deact_cause;          /* deactivation cause         */
    unsigned char  hpr_support;          /* TG HPR support            */
    unsigned char  anr_label[2];         /* local ANR label           */
    unsigned char  hpr_link_lvl_error;   /* HPR link-level error      */
    unsigned char  auto_act;             /* auto-activation supported  */
    unsigned char  ls_role;              /* LS role                    */
    unsigned char  ls_type;              /* LS type (defined,dynamic,..) */
    unsigned char  node_id[4];           /* determined node ID        */
    AP_UINT16      active_isr_count;     /* active isr count          */
    AP_UINT16      active_lu_sess_count; /* count of active LU sessions */
    AP_UINT16      active_sscp_sess_count; /* count of active SSCP sessions */
    ANR_LABEL      reverse_anr_label;    /* Reverse ANR label         */
    LINK_ADDRESS   local_address;        /* Local address             */
    AP_UINT16      max_send_btu_size;    /* Max send BTU size         */
    unsigned char  brnn_link_type;       /* type of branch link       */
    unsigned char  adj_cp_is_brnn;       /* is adjacent node a BrNN?  */
    unsigned char  mltg_member;          /* reserved                   */
    unsigned char  tg_sharing;           /* reserved                   */
    unsigned char  reservb[62];         /* reserved                   */
} LS_DET_DATA;
```

```
typedef struct ls_def_data
{
    unsigned char  description[32];      /* resource description        */
    unsigned char  initially_active;     /* is this LS initially active? */
    unsigned char  reserv2;              /* reserved                    */
    AP_UINT16      react_timer;          /* timer for retrying failed LS */
    AP_UINT16      react_timer_retry;    /* retry count for failed LS   */
    AP_UINT16      activation_count;     /* reserved                    */
    unsigned char  restart_on_normal_deact; /* restart the link on any    */
                                           /* failure                     */
    unsigned char  reserv3[7];           /* reserved                    */
    unsigned char  port_name[8];        /* name of associated port     */
    unsigned char  adj_cp_name[17];     /* adjacent CP name          */
}
```

```

unsigned char    adj_cp_type;           /* adjacent node type          */
LINK_ADDRESS    dest_address;          /* destination address         */
unsigned char    auto_act_supp;        /* auto-activate supported     */
unsigned char    tg_number;            /* pre-assigned TG number     */
unsigned char    limited_resource;     /* limited resource            */
unsigned char    solicit_sscp_sessions; /* solicit SSCP sessions      */
unsigned char    pu_name[8];           /* Local PU name (reserved if
                                        /* solicit_sscp_sessions is
                                        /* set to AP_NO)              */

unsigned char    disable_remote_act;   /* disable remote activation   */
unsigned char    dspu_services;        /* Services provided for
                                        /* downstream PU              */

unsigned char    dspu_name[8];         /* Downstream PU name (reserved
                                        /* if dspu_services is AP_NONE)*/

unsigned char    dlus_name[17];        /* DLUS name if dspu_services
                                        /* is AP_DLUR                  */

unsigned char    bkup_dlus_name[17];   /* Backup DLUS name if
                                        /* dspu_services is AP_DLUR    */

unsigned char    hpr_supported;        /* does the link support HPR?  */
unsigned char    hpr_link_lvl_error;   /* does link use link-level
                                        /* recovery for HPR frames?    */

AP_UINT16       link_deact_timer;      /* deact timer for limited
                                        /* resource                     */

unsigned char    reserv1;              /* reserved                    */
unsigned char    default_nn_server;    /* default LS to NN server?    */
unsigned char    ls_attributes[4];     /* LS attributes               */
unsigned char    adj_node_id[4];      /* adjacent node ID            */
unsigned char    local_node_id[4];    /* local node ID               */
unsigned char    cp_cp_sess_support;   /* CP-CP session support      */
unsigned char    use_default_tg_chars; /* Use default tg_chars       */
TG_DEFINED_CHARS tg_chars;            /* TG characteristics         */
AP_UINT16       target_pacing_count;   /* target pacing count         */
AP_UINT16       max_send_btu_size;     /* maximum send BTU size      */
AP_UINT16       ls_role;               /* link station role           */
unsigned char    max_ifrm_rcvd;        /* no. before acknowledgment   */
AP_UINT16       dlus_retry_timeout;    /* seconds to recontact a DLUS */
AP_UINT16       dlus_retry_limit;     /* attempts to recontact a DLUS */
unsigned char    conventional_lu_compression; /* compression for LU 0-3? */
unsigned char    conventional_lu_cryptography; /* reserved                    */
unsigned char    reserv3a;             /* reserved                    */
unsigned char    retry_flags;          /* reserved                    */
AP_UINT16       max_activation_attempts; /* reserved                    */
AP_UINT16       activation_delay_timer; /* reserved                    */
unsigned char    branch_link_type;     /* is link an up or down link  */
unsigned char    adj_brnn_cp_support;   /* adj CP allowed to be BrNN?  */
unsigned char    ml_tg_pacing_algorithm; /* reserved                    */
unsigned char    reserv5;              /* reserved                    */
AP_UINT16       max_rcv_btu_size;      /* reserved                    */
unsigned char    tg_sharing_prohibited; /* reserved                    */
unsigned char    link_spec_data_format; /* reserved                    */
unsigned char    pu_can_send_dddllu_offline; /* does the PU send NMVT
                                        /* (power off) to the host? */

unsigned char    reserv4[13];          /* reserved                    */
AP_UINT16       link_spec_data_len;    /* length of link specific data */
} LS_DEF_DATA;

```

```

typedef struct link_address
{
    unsigned char    format;           /* type of link address       */
    unsigned char    reserve1;         /* reserved                   */
    AP_UINT16       length;            /* length                     */
    unsigned char    address[32];      /* address                    */
} LINK_ADDRESS;

```

For Token Ring or Ethernet, the *address* parameter in the *link\_address* structure is replaced by the following:

```

typedef struct tr_address
{
    unsigned char    mac_address[6];    /* MAC address                */
    unsigned char    lsap_address;     /* local SAP address          */
} TR_ADDRESS;

```

## QUERY\_LS

For Enterprise Extender (HPR/IP), the *address* parameter in the *link\_address* structure is replaced by the following:

```
typedef struct ip_address_info
{
    unsigned char lsap;           /* Local Service Access Point addr */
    unsigned char version;       /* IPv4 or IPv6 */
    unsigned char address[272];  /* IP Address or hostname */
} IP_ADDRESS_INFO;
```

For all link types:

```
typedef struct tg_defined_chars
{
    unsigned char effect_cap;    /* Effective capacity */
    unsigned char reserve1[5];   /* Reserved */
    unsigned char connect_cost; /* Connection Cost */
    unsigned char byte_cost;    /* Byte cost */
    unsigned char reserve2;     /* Reserved */
    unsigned char security;     /* Security */
    unsigned char prop_delay;   /* Propagation delay */
    unsigned char modem_class;  /* reserved */
    unsigned char user_def_parm_1; /* User-defined parameter 1 */
    unsigned char user_def_parm_2; /* User-defined parameter 2 */
    unsigned char user_def_parm_3; /* User-defined parameter 3 */
} TG_DEFINED_CHARS;
```

```
typedef struct ls_stats
{
    AP_UINT32 in_xid_bytes;      /* number of XID bytes received */
    AP_UINT32 in_msg_bytes;     /* number of message bytes received */
    AP_UINT32 in_xid_frames;    /* number of XID frames received */
    AP_UINT32 in_msg_frames;    /* number of message frames received */
    AP_UINT32 out_xid_bytes;    /* number of XID bytes sent */
    AP_UINT32 out_msg_bytes;    /* number of message bytes sent */
    AP_UINT32 out_xid_frames;   /* number of XID frames sent */
    AP_UINT32 out_msg_frames;   /* number of message frames sent */
    AP_UINT32 in_invalid_sna_frames; /* number of invalid frames received */
    AP_UINT32 in_session_control_frames; /* number of control frames received */
    AP_UINT32 out_session_control_frames; /* number of control frames sent */
    AP_UINT32 echo_rsps;       /* reserved */
    AP_UINT32 current_delay;   /* reserved */
    AP_UINT32 max_delay;      /* reserved */
    AP_UINT32 min_delay;      /* reserved */
    AP_UINT32 max_delay_time; /* reserved */
    AP_UINT32 good_xids;      /* successful XID on LS count */
    AP_UINT32 bad_xids;       /* unsuccessful XID on LS count */
} LS_STATS;
```

For more details of the link-specific data, see “[DEFINE\\_LS](#)” on page 100. The data structure for this data follows the *ls\_def\_data* structure, but is padded to start on a 4-byte boundary.

## Supplied parameters

The application supplies the following parameters:

### **opcode**

AP\_QUERY\_LS

### **buf\_ptr**

A pointer to a data buffer that CS/AIX will use to return the requested information.

### **buf\_size**

Size of the supplied data buffer.

### **num\_entries**

Maximum number of LSs for which data should be returned. To request data for a specific LS rather than a range, specify the value 1. To return as many entries as possible, specify zero; in this case,

CS/AIX will return the maximum number of entries that can be accommodated in the supplied data buffer.

### ***list\_options***

The position in the list from which CS/AIX should begin to return data, and the level of information required for each entry. Specify the level of information with one of the following values:

#### **AP\_SUMMARY**

Summary information only.

#### **AP\_DETAIL**

Detailed information.

Combine this value using a logical OR operation with one of the following values:

#### **AP\_FIRST\_IN\_LIST**

Start at the first entry in the list.

#### **AP\_LIST\_INCLUSIVE**

Start at the entry specified by the *ls\_name* parameter.

#### **AP\_LIST\_FROM\_NEXT**

Start at the entry immediately following the entry specified by the *ls\_name* parameter.

For more information about how the list is ordered and how the application can obtain specific entries from it, see [“List options for QUERY\\_\\* Verbs” on page 33](#).

### ***ls\_name***

Link station name. This is an 8-byte ASCII string, padded on the right with spaces if the name is shorter than 8 characters. This value is ignored if *list\_options* is set to AP\_FIRST\_IN\_LIST.

### ***port\_name***

Port name filter. To return information only on LSs associated with a specific port, specify the name of the port. This is an 8-byte ASCII string, padded on the right with spaces if the name is shorter than 8 characters. To return information about all LSs without filtering on the port name, set this parameter to 8 binary zeros.

## **Returned parameters: successful execution**

If the verb executes successfully, CS/AIX returns the following parameters:

### ***primary\_rc***

AP\_OK

### ***buf\_size***

Length of the information returned in the supplied buffer.

### ***total\_buf\_size***

Returned value indicating the size of buffer that would have been required to return all the list information requested. A value greater than *buf\_size* indicates that not all the available entries were returned.

### ***num\_entries***

Number of entries returned in the data buffer.

### ***total\_num\_entries***

Total number of entries available. A value greater than *num\_entries* indicates that not all the available entries were returned.

Each entry in the data buffer consists of the following parameters:

### ***ls\_summary.overlay\_size***

The size of the returned *ls\_summary* structure, and therefore the offset to the start of the next entry in the data buffer.

When your application needs to go through the returned buffer to find each *ls\_summary* structure in turn, it must use this value to move to the correct offset for the next data structure, and must not use the C `sizeof()` operator. This is because the size of the returned overlay may increase in future

releases of CS/AIX; using the returned overlay size ensures that your application will continue to work with future releases.

***ls\_summary.ls\_name***

Link station name. This is an 8-byte ASCII string, padded on the right with spaces if the name is shorter than 8 characters.

***ls\_summary.description***

A null-terminated text string describing the LS, as specified in the definition of the LS.

***ls\_summary.dlc\_type***

Type of DLC. This is one of the following:

**AP\_SDLC**

SDLC

**AP\_X25**

QLLC

**AP\_TR**

Token Ring

**AP\_ETHERNET**

Ethernet

**AP\_IP**

Enterprise Extender (HPR/IP)

***ls\_summary.state***

State of this link station. This is one of the following:

**AP\_ACTIVE**

The LS is active.

**AP\_NOT\_ACTIVE**

The LS is not active.

**AP\_PENDING\_ACTIVE**

The LS is being activated.

**AP\_PENDING\_INACTIVE**

The LS is being deactivated.

**AP\_PENDING\_ACTIVE\_BY\_LR**

The LS has failed (or an attempt to activate it has failed), and CS/AIX is attempting to reactivate it.

***ls\_summary.act\_sess\_count***

The total number of active sessions (both endpoint and intermediate) using the link.

***ls\_summary.det\_adj\_cp\_name***

Fully qualified name of the adjacent control point. The name is a 17-byte EBCDIC string, padded on the right with EBCDIC spaces. It consists of a network ID of 1-8 A-string characters, an EBCDIC dot (period) character, and a network name of 1-8 A-string characters.

This name is normally determined during activation; it is null if the LS is inactive. However, for an LS to a back-level LEN node (specified by the *adj\_cp\_type* parameter on DEFINE\_LS), this name is taken from the LS definition and is not determined during activation.

***ls\_summary.det\_adj\_cp\_type***

Type of the adjacent node. This is one of the following:

**AP\_APPN\_NODE**

Node type is unknown, or LS is inactive.

**AP\_END\_NODE**

End node, Branch Network Node acting as an End Node from the local node's perspective, or up-level LEN node (one that includes the Network Name CV in its XID3).

**AP\_NETWORK\_NODE**

Network node, or Branch Network Node acting as a Network Node from the local node's perspective.



**AP\_VRN**

Virtual routing node.

The node type is normally determined during activation; it is null if the LS is inactive. However, for an LS to a back-level LEN node (specified by the *adj\_cp\_type* parameter on DEFINE\_LS), the node type is taken from the LS definition and is not determined during activation.

***ls\_summary.port\_name***

Name of the port associated with this link station. This is an 8-byte ASCII string, padded on the right with spaces if the name is shorter than 8 characters.

***ls\_summary.adj\_cp\_name***

Fully qualified name of the adjacent control point; this parameter is null for an implicit link. The name is a 17-byte EBCDIC string, padded on the right with EBCDIC spaces. It consists of a network ID of 1-8 A-string characters, an EBCDIC dot (period) character, and a network name of 1-8 A-string characters.

***ls\_summary.adj\_cp\_type***

Type of the adjacent node, determined during link activation. This is one of the following:

**AP\_APPN\_NODE**

Node type is unknown, or LS is inactive.

**AP\_END\_NODE**

End node, Branch Network Node acting as an End Node from the local node's perspective, or up-level LEN node (one that includes the Network Name CV in its XID3).

**AP\_NETWORK\_NODE**

Network node, or Branch Network Node acting as a Network Node from the local node's perspective.

**AP\_BACK\_LEVEL\_LEN\_NODE**

Back-level LEN node (one that does not include the Network Name CV in its XID3).

**AP\_HOST\_XID3**

Host node; CS/AIX should respond to a polling XID from the node with a format 3 XID.

**AP\_HOST\_XID0**

Host node; CS/AIX should respond to a polling XID from the node with a format 0 XID.

**AP\_DSPU\_XID**

Downstream PU; CS/AIX should include XID exchange in link activation. The *dspu\_name* and *dspu\_services* fields must also be set.

**AP\_DSPU\_NOXID**

Downstream PU; CS/AIX should not include XID exchange in link activation. The *dspu\_name* and *dspu\_services* fields must also be set.

**AP\_VRN**

Virtual routing node.

***ls\_detail.overlay\_size***

The size of the returned *ls\_detail* structure, and therefore the offset to the start of the next entry in the data buffer.

When your application needs to go through the returned buffer to find each *ls\_detail* structure in turn, it must use this value to move to the correct offset for the next data structure, and must not use the C `sizeof()` operator. This is because the size of the returned overlay may increase in future releases of CS/AIX; using the returned overlay size ensures that your application will continue to work with future releases.

***ls\_detail.ls\_name***

Link station name. This is an 8-byte ASCII string, padded on the right with spaces if the name is shorter than 8 characters.

***ls\_detail.det\_data.act\_sess\_count***

The total number of active sessions (both endpoint and intermediate) using the link.

***ls\_detail.det\_data.dlc\_type***

Type of DLC. This is one of the following:

**AP\_SDLC**

SDLC

**AP\_X25**

QLLC

**AP\_TR**

Token Ring

**AP\_ETHERNET**

Ethernet

**AP\_IP**

Enterprise Extender (HPR/IP)

***ls\_detail.det\_data.state***

State of this link station. This is one of the following:

**AP\_ACTIVE**

The LS is active.

**AP\_NOT\_ACTIVE**

The LS is not active.

**AP\_PENDING\_ACTIVE**

The LS is being activated.

**AP\_PENDING\_INACTIVE**

The LS is being deactivated.

**AP\_PENDING\_ACTIVE\_BY\_LR**

The LS has failed (or an attempt to activate it has failed), and CS/AIX is attempting to reactivate it.

***ls\_detail.det\_data.sub\_state***

This field provides more detailed information about the state of this link station. Possible values are:

AP\_SENT\_CONNECT\_OUT

AP\_PENDING\_XID\_EXCHANGE

AP\_SENT\_ACTIVATE\_AS

AP\_SENT\_SET\_MODE

AP\_ACTIVE

AP\_SENT\_DEACTIVATE\_AS\_ORDERLY

AP\_SENT\_DISCONNECT

AP\_WAITING\_STATS

AP\_RESET

***ls\_detail.det\_data.det\_adj\_cp\_name***

Fully qualified name of the adjacent control point. The name is a 17-byte EBCDIC string, padded on the right with EBCDIC spaces. It consists of a network ID of 1-8 A-string characters, an EBCDIC dot (period) character, and a network name of 1-8 A-string characters.

This name is normally determined during activation; it is null if the LS is inactive. However, for an LS to a back-level LEN node (specified by the *adj\_cp\_type* parameter on DEFINE\_LS), this name is taken from the LS definition and is not determined during activation.

***ls\_detail.det\_data.det\_adj\_cp\_type***

Type of the adjacent node. This is one of the following:

**AP\_END\_NODE**

End node, or Branch Network Node acting as an End Node from the local node's perspective.

**AP\_NETWORK\_NODE**

Network node, or Branch Network Node acting as a Network Node from the local node's perspective.

**AP\_LEARN\_NODE**

Node type is unknown.

The node type is normally determined during activation; it is null if the LS is inactive. However, for an LS to a back-level LEN node (specified by the *adj\_cp\_type* parameter on DEFINE\_LS), the node type is taken from the LS definition and is not determined during activation.

***ls\_detail.det\_data.dlc\_name***

Name of the DLC. This is an 8-byte ASCII string, padded on the right with spaces if the name is shorter than 8 characters.

***ls\_detail.det\_data.dynamic***

Specifies whether the link was defined dynamically. Possible values are:

**AP\_YES**

The link was defined dynamically (in response to a connection request from the adjacent node, or to connect dynamically to another node across a Connection Network).

**AP\_NO**

The link was defined explicitly (by DEFINE\_LS).

***ls\_detail.det\_data.migration***

Specifies whether the adjacent node is a migration level node (such as a Low Entry Networking or LEN node), or a full APPN network node or end node. Possible values are:

**AP\_YES**

The adjacent node is a migration-level node.

**AP\_NO**

The adjacent node is a network node or end node.

**AP\_UNKNOWN**

The adjacent node level is unknown.

***ls\_detail.det\_data.tg\_num***

Number associated with the TG.

***ls\_detail.det\_data.ls\_stats.in\_xid\_bytes***

Total number of XID (Exchange Identification) bytes received on this link station.

***ls\_detail.det\_data.ls\_stats.in\_msg\_bytes***

Total number of data bytes received on this link station.

***ls\_detail.det\_data.ls\_stats.in\_xid\_frames***

Total number of XID (Exchange Identification) frames received on this link station.

***ls\_detail.det\_data.ls\_stats.in\_msg\_frames***

Total number of data frames received on this link station.

***ls\_detail.det\_data.ls\_stats.out\_xid\_bytes***

Total number of XID (Exchange Identification) bytes sent on this link station.

***ls\_detail.det\_data.ls\_stats.out\_msg\_bytes***

Total number of data bytes sent on this link station.

***ls\_detail.det\_data.ls\_stats.out\_xid\_frames***

Total number of XID (Exchange Identification) frames sent on this link station.

***ls\_detail.det\_data.ls\_stats.out\_msg\_frames***

Total number of data frames sent on this link station.

***ls\_detail.det\_data.ls\_stats.in\_invalid\_sna\_frames***

Total number of not valid SNA frames received on this link station.

***ls\_detail.det\_data.ls\_stats.in\_session\_control\_frames***

Total number of session control frames received on this link station.

***ls\_detail.det\_data.ls\_stats.out\_session\_control\_frames***

Total number of session control frames sent on this link station.

***ls\_detail.det\_data.ls\_stats.good\_xids***

Total number of successful XID exchanges that have occurred on this link station since it was started.

***ls\_detail.det\_data.ls\_stats.bad\_xids***

Total number of unsuccessful XID exchanges that have occurred on this link station since it was started.

***ls\_detail.det\_data.start\_time***

Time since system startup (in hundredths of a second) when the link station was last activated (that is, when the mode setting commands completed).

***ls\_detail.det\_data.stop\_time***

Time since system startup (in hundredths of a second) when the link station was last deactivated.

***ls\_detail.det\_data.up\_time***

Total time (in hundredths of a second) that this link station has been active since system startup.

***ls\_detail.det\_data.current\_state\_time***

Total time (in hundredths of a second) that this link station has been in its current state.

***ls\_detail.det\_data.deact\_cause***

The cause of the last deactivation of the link station. Possible values are:

**AP\_NONE**

The link station has never been deactivated.

**AP\_DEACT\_OPER\_ORDERLY**

The link station was deactivated as a result of an orderly STOP command from an operator.

**AP\_DEACT\_OPER\_IMMEDIATE**

The link station was deactivated as a result of an immediate STOP command from an operator.

**AP\_DEACT\_AUTOMATIC**

The link station was deactivated automatically, for example because there were no more sessions using the link station.

**AP\_DEACT\_FAILURE**

The link station was deactivated because of a failure.

***ls\_detail.det\_data.hpr\_support***

Level of High Performance Routing (HPR) supported on this transmission group (TG), taking account of the capabilities of the local and adjacent nodes. Possible values are:

**AP\_NONE**

This TG does not support HPR protocols.

**AP\_BASE**

This TG supports base level HPR.

**AP\_RTP**

This TG supports Rapid Transport Protocols (RTP).

***ls\_detail.det\_data.anr\_label***

The HPR automatic network routing (ANR) label allocated to the local link.

***ls\_detail.det\_data.hpr\_link\_lvl\_error***

For SDLC, this parameter is reserved.

For other port types, this parameter specifies whether link-level error recovery is being used for HPR traffic on the link.

***ls\_detail.det\_data.auto\_act***

Specifies whether the link currently allows remote activation or activation on demand. This is set to AP\_NONE if neither is allowed, or to one or both of the following values (combined using a logical OR):

**AP\_AUTO\_ACT**

The link can be activated on demand by the local node when a session requires it.

**AP\_REMOTE\_ACT**

The link can be activated by the remote node.

***ls\_detail.det\_data.ls\_role***

The LS role of this link. This is normally taken from the definition of the port that owns the LS (or from the definition of the LS, if this overrides the LS role in the port definition). However, if the LS role is defined to be negotiable, it will be negotiated to either primary or secondary while the LS is active; if this verb is used to query an active LS, the returned LS role is the negotiated role currently in use and not the defined role. Possible values are:

**AP\_LS\_PRI**

Primary.

**AP\_LS\_SEC**

Secondary.

**AP\_LS\_NEG**

Negotiable.

***ls\_detail.det\_data.ls\_type***

Specifies how this link was defined or discovered. Possible values are:

**AP\_LS\_DEFINED**

The link station was defined explicitly by a CS/AIX administration program.

**AP\_LS\_DYNAMIC**

The link station was created when the local node connected to another node through a connection network.

**AP\_LS\_TEMPORARY**

The link station was created temporarily to process an incoming call, but has not yet become active.

**AP\_LS\_IMPLICIT**

The link station was defined implicitly when CS/AIX received an incoming call that it could not match to a defined link station.

**AP\_LS\_DLUS\_DEFINED**

The link station is a dynamic link station to a DLUR-served downstream PU, and was defined when the local node received an ACTPU from a DLUS.

***ls\_detail.det\_data.node\_id***

Node ID received from adjacent node during XID exchange. This is a 4-byte hexadecimal string.

***ls\_detail.det\_data.active\_isr\_count***

Number of active intermediate sessions using the link.

***ls\_detail.det\_data.active\_lu\_sess\_count***

The count of active LU-LU sessions using this link.

***ls\_detail.det\_data.active\_sscp\_sess\_count***

The count of active PU-SSCP sessions using this link.

***ls\_detail.det\_data.reverse\_anr\_label***

The Reverse Automatic Network Routing (ANR) label for this link station.

For SDLC:

***ls\_detail.det\_data.local\_address***

The local address of this link station.

For QLLC:

***ls\_detail.det\_data.local\_address***

The local address of this link station.

For Token Ring, Ethernet:

***ls\_detail.det\_data.local\_address.mac\_address***

MAC address of the local link station.

***ls\_detail.det\_data.local\_address.lsap\_address***

Local SAP address of the local link station.

For Enterprise Extender:

***ls\_detail.det\_data.local\_address.ip\_address\_info.lsap***

For Enterprise Extender: Local SAP address of the port. Specify a multiple of 0x04 in the range 0x04-0xEC. The usual value is 0x04, but VTAM may use 0x08 in some circumstances.

If you need to use two or more ports with different LSAP addresses on the same TCP/IP interface, you will need to create two or more Enterprise Extender DLCs, and then create a separate Enterprise Extender port for each DLC with the same *if\_name* but a different LSAP address.

***ls\_detail.det\_data.local\_address.ip\_address\_info.version***

For Enterprise Extender: Specifies whether the following field represents an IPv4 or IPv6 address. Possible values:

**IP\_VERSION\_4\_HOSTNAME**

The *address* field specifies an IPv4 address, or a hostname or alias that resolves to an IPv4 address.

**IP\_VERSION\_6\_HOSTNAME**

The *address* field specifies an IPv6 address, or a hostname or alias that resolves to an IPv6 address.

***ls\_detail.det\_data.local\_address.ip\_address\_info.address***

For Enterprise Extender: IP address of the port. This can be any of the following.

- An IPv4 dotted-decimal address (such as 193.1.11.100).
- An IPv6 colon-hexadecimal address (such as 2001:0db8:0000:0000:0000:0000:1428:57ab or 2001:db8::1428:57ab).
- A name (such as newbox.this.co.uk).
- An alias (such as newbox).

***ls\_detail.det\_data.max\_send\_btu\_size***

Maximum BTU size that can be sent on this link, as determined by negotiation with the adjacent node. If the link activation has not yet been attempted, a zero value is returned.

***ls\_detail.det\_data.brnn\_link\_type***

This parameter applies only if the local node is a Branch Network Node; it is reserved otherwise.

Specifies the branch link type of this link. Possible values are:

**AP\_UPLINK**

The link is an uplink.

**AP\_DOWNLINK**

The link is a downlink.

**AP\_OTHERLINK**

The link is to a VRN.

**AP\_UNKNOWN\_LINK\_TYPE**

The branch link type is unknown.

**AP\_BRNN\_NOT\_SUPPORTED**

The link supports PU 2.0 traffic only.

***ls\_detail.det\_data.adj\_cp\_is\_brnn***

Specifies whether the adjacent node is a Branch Network Node. Possible values are:

**AP\_YES**

The adjacent node is a Branch Network Node.

**AP\_NO**

The adjacent node is not a Branch Network Node.

**AP\_UNKNOWN**

The adjacent node type is unknown.

***ls\_detail.def\_data.description***

A null-terminated text string describing the LS, as specified in the definition of the LS.

***ls\_detail.def\_data.initially\_active***

Specifies whether this LS is automatically started when the node is started. Possible values are:

**AP\_YES**

The LS is automatically started when the node is started.

**AP\_NO**

The LS is not automatically started; it must be started manually.

***ls\_detail.def\_data.react\_timer***

Reactivation timer for reactivating a failed LS. If the *react\_timer\_retry* parameter below is nonzero, to specify that CS/AIX should retry activating the LS if it fails, this parameter specifies the time in seconds between retries. When the LS fails, or when an attempt to reactivate it fails, CS/AIX waits for the specified time before retrying the activation. If *react\_timer\_retry* is zero, this parameter is ignored.

***ls\_detail.def\_data.react\_timer\_retry***

Retry count for reactivating a failed LS. This parameter is used to specify whether CS/AIX should attempt to reactivate the LS if it fails while in use (or if an attempt to start the LS fails).

Zero indicates that CS/AIX should not attempt to reactivate the LS; a nonzero value specifies the number of retries to be made. A value of 65,535 indicates that CS/AIX should retry indefinitely until the LS is activated.

CS/AIX waits for the time specified by the *react\_timer* parameter above between successive retries. If the retry count is reached without successfully reactivating the LS, or if a STOP\_LS is issued while CS/AIX is retrying the activation, no further retries are made; the LS remains inactive unless START\_LS is issued for it.

If the *auto\_act\_supp* parameter is set to AP\_YES, the reactivation timer fields are ignored; if the link fails, CS/AIX does not attempt to reactivate it until the user application that was using the session attempts to restart the session.

***ls\_detail.def\_data.restart\_on\_normal\_deact***

Specifies whether CS/AIX should attempt to reactivate the LS if it is deactivated normally by the remote system. Possible values are:

**AP\_YES**

If the remote system deactivates the LS normally, CS/AIX attempts to reactivate it, using the same retry timer and count values as for reactivating a failed LS (the *react\_timer* and *react\_timer\_retry* parameters above).

**AP\_NO**

If the remote system deactivates the LS normally, CS/AIX does not attempt to reactivate it.

If the LS is a host link (specified by the *adj\_cp\_type* parameter), or is automatically started when the node is started (the *initially\_active* parameter is set to AP\_YES), this parameter is ignored; CS/AIX always attempts to reactivate the LS if it is deactivated normally by the remote system (unless *react\_timer\_retry* is zero).

***ls\_detail.def\_data.port\_name***

Name of the port associated with this link station. This is an 8-byte ASCII string, padded on the right with spaces if the name is shorter than 8 characters. If the link is to a VRN, this field specifies the name of the actual port used to connect to the VRN (as specified in the DEFINE\_CN verb).

***ls\_detail.def\_data.adj\_cp\_name***

Fully qualified name of the adjacent control point. This parameter is used only if *adj\_cp\_type* specifies that the adjacent node is an APPN node or a back-level LEN node.

The name is a 17-byte EBCDIC string, padded on the right with EBCDIC spaces. It consists of a network ID of 1-8 A-string characters, an EBCDIC dot (period) character, and a network name of 1-8 A-string characters.

***ls\_detail.def\_data.adj\_cp\_type***

Adjacent node type. This is one of the following:

**AP\_APPN\_NODE**

APPN-capable node; the node type will be learned during XID exchange.

**AP\_NETWORK\_NODE**

Network node, or Branch Network Node acting as a Network Node from the local node's perspective.

**AP\_END\_NODE**

End node, Branch Network Node acting as an End Node from the local node's perspective, or up-level LEN node (one that includes the Network Name CV in its XID3).

**AP\_BACK\_LEVEL\_LEN\_NODE**

Back-level LEN node (one that does not include the Network Name CV in its XID3).

**AP\_HOST\_XID3**

Host node; CS/AIX responds to a polling XID from the node with a format 3 XID.

**AP\_HOST\_XID0**

Host node; CS/AIX responds to a polling XID from the node with a format 0 XID.

**AP\_DSPU\_XID**

Downstream PU; CS/AIX includes XID exchange in link activation.

**AP\_DSPU\_NOXID**

Downstream PU; CS/AIX does not include XID exchange in link activation.

For SDLC:

***ls\_detail.def\_data.dest\_address***

Address of the secondary link station.

The value of this parameter depends on how the port that owns this LS is configured, as follows:

- If the port is used only for incoming calls (*out\_link\_act\_lim* on DEFINE\_PORT is 0), this parameter is reserved.
- If the port is switched primary and is used for outgoing calls (*port\_type* is PORT\_SWITCHED, *ls\_role* is LS\_PRI, and *out\_link\_act\_lim* on DEFINE\_PORT is a nonzero value), this parameter is set to either 0xFF to accept whatever address is configured at the secondary station, or to a 1-byte value in the range 0x01-0xFE (this value must match the value configured at the secondary station).
- For all other port configurations, this parameter is set to a 1-byte value in the range 0x01-0xFE to identify the link station. If the port is primary multi-drop (*ls\_role* on DEFINE\_PORT is LS\_PRI and *tot\_link\_act\_lim* is greater than 1), this address must be different for each LS on the port.

For QLLC:

***ls\_detail.def\_data.dest\_address***

Destination address of link station on the adjacent node. This parameter is used only for SVC outgoing calls (defined by the *vc\_type* parameter in the link-specific data, and by the link activation limit parameters on DEFINE\_PORT); it is ignored for incoming calls or for PVC.

For Token Ring, Ethernet:

***ls\_detail.def\_data.dest\_address.mac\_address***

MAC address of link station on adjacent node.

If this parameter is null, the LS is a non-selective listening LS (one that can be used only for incoming calls, but can have LUs defined on it to support dependent LU traffic). The LS can be used to receive incoming calls from any remote link station, but cannot be used for outgoing calls.

If the local and adjacent nodes are on LANs of different types (one Token Ring, the other Ethernet) connected by a bridge, you will probably need to reverse the bit order of the bytes in the MAC address. For more information, see [“Bit ordering in MAC addresses”](#) on page 125. If the two nodes are on the same LAN, or on LANs of the same type connected by a bridge, no change is required.



***ls\_detail.def\_data.dest\_address.lsap\_address***

Local SAP address of link station on adjacent node.

For Enterprise Extender (HPR/IP):

***ls\_detail.def\_data.dest\_address.ip\_address\_info.lsap***

Local SAP address of link station on adjacent node. Specify a multiple of 0x04 in the range 0x04-0xEC. The usual value is 0x04, but VTAM may use 0x08 in some circumstances.

***ls\_detail.def\_data.dest\_address.ip\_address\_info.version***

Specifies whether the following field represents an IPv4 or IPv6 address. Possible values:

**IP\_VERSION\_4\_HOSTNAME**

The *address* field specifies an IPv4 address, or a hostname or alias that resolves to an IPv4 address.

**IP\_VERSION\_6\_HOSTNAME**

The *address* field specifies an IPv6 address, or a hostname or alias that resolves to an IPv6 address.

***ls\_detail.def\_data.dest\_address.ip\_address\_info.address***

IP address of link station on adjacent node. This can be either of the following.

- An IPv4 dotted-decimal address (such as 193.1.11.100).
- An IPv6 colon-hexadecimal address (such as 2001:0db8:0000:0000:0000:0000:1428:57ab or 2001:db8::1428:57ab).

For all link types:

***ls\_detail.def\_data.auto\_act\_supp***

Specifies whether the link can be activated automatically when required by a session. Possible values are:

**AP\_YES**

The link can be activated automatically.

**AP\_NO**

The link cannot be activated automatically.

***ls\_detail.def\_data.tg\_number***

Preassigned TG number, used to represent the link when the link is activated. This parameter is used only if the adjacent node is an APPN node (*adj\_cp\_type* is either AP\_NETWORK\_NODE or AP\_END\_NODE); it is ignored otherwise. Zero indicates that the TG number is not preassigned and is negotiated when the link is activated.

***ls\_detail.def\_data.limited\_resource***

Specifies whether this link station is to be deactivated when there are no sessions using the link. Possible values are:

**AP\_NO**

The link is not a limited resource and will not be deactivated automatically.

**AP\_NO\_SESSIONS**

The link is a limited resource and will be deactivated automatically when no active sessions are using it.

**AP\_INACTIVITY**

The link is a limited resource and will be deactivated automatically when no active sessions are using it, or when no data has flowed on the link for the time period specified by the *link\_deact\_timer* field.

***ls\_detail.def\_data.solicit\_sscp\_sessions***

Specifies whether to request the adjacent node to initiate sessions between the SSCP and the local CP and dependent LUs. This parameter is used only if the adjacent node is an APPN node (*adj\_cp\_type* is either AP\_NETWORK\_NODE or AP\_END\_NODE); it is ignored otherwise. If the adjacent node is a host (*adj\_cp\_type* is either AP\_HOST\_XID3 or AP\_HOST\_XID0), CS/AIX always requests the host to initiate SSCP sessions.

This parameter is not used for Enterprise Extender (HPR/IP) links.

Possible values are:

**AP\_YES**

Request the adjacent node to initiate SSCP sessions.

**AP\_NO**

Do not request the adjacent node to initiate SSCP sessions.

***ls\_detail.def\_data.pu\_name***

Name of the local PU that uses this link. This parameter is used only if *adj\_cp\_type* is set to AP\_HOST\_XID3 or AP\_HOST\_XID0, or if *solicit\_sscp\_sessions* is set to AP\_YES; it is reserved otherwise.

This parameter is not used for Enterprise Extender (HPR/IP) links.

The PU name is an 8-byte alphanumeric type-A EBCDIC string (starting with a letter), padded on the right with EBCDIC spaces.

***ls\_detail.def\_data.disable\_remote\_act***

Specifies whether the LS can be activated by a remote node. Possible values are:

**AP\_YES**

The LS can only be activated by the local node; if the remote node attempts to activate it, CS/AIX will reject the attempt.

**AP\_NO**

The LS can be activated by the remote node.

***ls\_detail.def\_data.dspu\_services***

Specifies the services which the local node will provide to the downstream PU across this link. This parameter is used only if the adjacent node is a downstream PU or an APPN node with *solicit\_sscp\_sessions* set to AP\_NO; it is reserved otherwise. Possible values are:

**AP\_PU\_CONCENTRATION**

Local node will provide SNA gateway for the downstream PU.

**AP\_DLUR**

Local node will provide DLUR services for the downstream PU.

**AP\_NONE**

Local node will provide no services for this downstream PU.

***ls\_detail.def\_data.dspu\_name***

Name of the downstream PU. This parameter is required if *solicit\_sscp\_sessions* is set to AP\_NO and *dspu\_services* is set to AP\_PU\_CONCENTRATION or AP\_DLUR; it is reserved otherwise. The name is an 8-byte type-A EBCDIC string (starting with a letter), padded on the right with EBCDIC spaces.

***ls\_detail.def\_data.dlus\_name***

Name of the DLUS node from which DLUR solicits SSCP services when the link to the downstream node is activated. This field is reserved if *dspu\_services* is not set to AP\_DLUR.

The name is a 17-byte EBCDIC string, right-padded with EBCDIC spaces. It consists of a network ID of up to 8 A-string characters, an EBCDIC dot (period) character, and a network name of up to 8 A-string characters.

A string of 17 binary zeros indicates the global default DLUS, defined using the DEFINE\_DLUR\_DEFAULTS verb. If this parameter is set to zeros and there is no global default DLUS, then DLUR will not initiate SSCP contact when the link is activated.

***ls\_detail.def\_data.bkup\_dlus\_name***

Name of the DLUS node from which DLUR solicits SSCP services when the link to the downstream node is activated. This field is reserved if *dspu\_services* is not set to AP\_DLUR.

The name is a 17-byte EBCDIC string, right-padded with EBCDIC spaces. It consists of a network ID of up to 8 A-string characters, an EBCDIC dot (period) character, and a network name of up to 8 A-string characters.

A string of 17 binary zeros indicates the global backup default DLUS, defined using the DEFINE\_DLUR\_DEFAULTS verb.

***ls\_detail.def\_data.hpr\_supported***

Specifies whether HPR is supported on this link. Possible values are:

**AP\_YES**

HPR is supported on this link.

**AP\_NO**

HPR is not supported on this link.

***ls\_detail.def\_data.hpr\_link\_lvl\_error***

For SDLC, this parameter is reserved.

For other port types, this parameter specifies whether link-level error recovery is supported for HPR traffic on the link.

This parameter is reserved if the *ls\_detail.def\_data.hpr\_supported* parameter is set to AP\_NO. Possible values are:

**AP\_YES**

The HPR link-level error recovery tower is supported on this link.

**AP\_NO**

The HPR link-level error recovery tower is not supported on this link.

***ls\_detail.def\_data.link\_deact\_timer***

Limited resource link deactivation timer (in seconds, minimum 5). If *limited\_resource* is set to AP\_INACTIVITY, the link will be deactivated if no data flows on it for the time specified by this parameter. A value of zero indicates no timeout (the link is not deactivated, as though *limited\_resource* were set to AP\_NO), and that values in the range 1-4 are interpreted as 5.

***ls\_detail.def\_data.default\_nn\_server***

End node: Specifies whether this is a link supporting CP-CP sessions to a network node that can act as the local node's network node server. When the local node has no CP-CP sessions to a network node server and needs to establish them, it checks this parameter on its defined LSs to find a suitable LS to activate. This allows you to specify which adjacent NNs are suitable to act as the NN server (for example, to avoid using NNs that are accessed by expensive or slow links).

Possible values are:

**AP\_YES**

This link supports CP-CP sessions to a network node that can act as the local node's NN server; the local node can automatically activate this link if it needs to contact an NN server.

**AP\_NO**

This link should not be automatically activated in an attempt to contact a network node server.

If the local node is not an end node, this parameter is reserved.

***ls\_detail.def\_data.ls\_attributes***

This array contains further information about the adjacent node, as described in the following parameters:

***ls\_detail.def\_data.ls\_attributes[0]***

Host type (normally standard SNA). Possible values are:

**AP\_SNA**

Standard SNA host.

**AP\_FNA**

Fujitsu Network Architecture (VTAM-F) host.

**AP\_HNA**

Hitachi Network Architecture host.

***ls\_detail.def\_data.ls\_attributes[1]***

Network Name CV suppression for a link to a back-level LEN node.

If *adj\_cp\_type* is set to AP\_BACK\_LEVEL\_LEN\_NODE, this parameter specifies whether to suppress inclusion of the Network Name CV in the format 3 XID sent to the LEN node. Possible values are:

**AP\_NO**

Include the Network Name CV in the XID.

**AP\_SUPPRESS\_CP\_NAME**

Do not include the Network name CV.

If *adj\_cp\_type* is set to any other value, this parameter is reserved.

***ls\_detail.def\_data.adj\_node\_id***

Node ID of adjacent node. This is a 4-byte hexadecimal string; a value of 4 zeros indicates that node ID checking is disabled.

***ls\_detail.def\_data.local\_node\_id***

Node ID sent in XIDs on this LS. This is a 4-byte hexadecimal string, consisting of a block number (3 hexadecimal digits) and a node number (5 hexadecimal digits). A value of all zeros indicates that CS/AIX uses the node ID specified in the DEFINE\_NODE verb.

***ls\_detail.def\_data.cp\_cp\_sess\_support***

Specifies whether CP-CP sessions are supported. Possible values are:

**AP\_YES**

CP-CP sessions are supported.

**AP\_NO**

CP-CP sessions are not supported.

***ls\_detail.def\_data.use\_default\_tg\_chars***

Specifies whether the default TG characteristics supplied on the DEFINE\_PORT verb are used. Possible values are:

**AP\_YES**

Use the default TG characteristics; ignore the *tg\_chars* structure on this verb.

**AP\_NO**

Use the *tg\_chars* structure on this verb.

***ls\_detail.def\_data.tg\_chars.effect\_cap***

Actual bits per second rate (line speed). The value is encoded as a 1-byte floating point number, represented by the formula  $0.1 \text{ mmm} * 2^{\text{eeee}}$  where the bit representation of the byte is *b'eeeeemmm'*. Each unit of effective capacity is equal to 300 bits per second.

***ls\_detail.def\_data.tg\_chars.connect\_cost***

Cost per connect time. Valid values are integer values in the range 0-255, where 0 is the lowest cost per connect time and 255 is the highest.

***ls\_detail.def\_data.tg\_chars.byte\_cost***

Cost per byte. Valid values are integer values in the range 0-255, where 0 is the lowest cost per byte and 255 is the highest.

***ls\_detail.def\_data.tg\_chars.security***

Security level of the network. Possible values are:

**AP\_SEC\_NONSECURE**

No security.

**AP\_SEC\_PUBLIC\_SWITCHED\_NETWORK**

Data is transmitted over a public switched network.

**AP\_SEC\_UNDERGROUND\_CABLE**

Data is transmitted over secure underground cable.

**AP\_SEC\_SECURE\_CONDUIT**

Data is transmitted over a line in a secure conduit that is not guarded.

**AP\_SEC\_GUARDED\_CONDUIT**

Data is transmitted over a line in a conduit that is protected against physical tapping.

**AP\_SEC\_ENCRYPTED**

Data is encrypted before transmission over the line.

**AP\_SEC\_GUARDED\_RADIATION**

Data is transmitted over a line that is protected against physical and radiation tapping.

**AP\_SEC\_MAXIMUM**

Maximum security.

***ls\_detail.def\_data.tg\_chars.prop\_delay***

Propagation delay: the time that a signal takes to travel the length of the link. Possible values are:

**AP\_PROP\_DELAY\_MINIMUM**

Minimum propagation delay.

**AP\_PROP\_DELAY\_LAN**

Delay is less than 480 microseconds (typical for a LAN).

**AP\_PROP\_DELAY\_TELEPHONE**

Delay is in the range 480-49,512 microseconds (typical for a telephone network).

**AP\_PROP\_DELAY\_PKT\_SWITCHED\_NET**

Delay is in the range 49,512-245,760 microseconds (typical for a packet-switched network).

**AP\_PROP\_DELAY\_SATELLITE**

Delay is greater than 245,760 microseconds (typical for a satellite link).

**AP\_PROP\_DELAY\_MAXIMUM**

Maximum propagation delay.

***ls\_detail.def\_data.tg\_chars.user\_def\_parm\_1* through *def\_data.tg\_chars.user\_def\_parm\_3***

User-defined parameters, which include other TG characteristics not covered by the above parameters. Each of these parameters is set to a value in the range 0-255.

***ls\_detail.def\_data.target\_pacing\_count***

Numeric value between 1 and 32,767 inclusive indicating the desired pacing window size. (The current version of CS/AIX does not make use of this value.)

***ls\_detail.def\_data.max\_send\_btu\_size***

Maximum BTU size that can be sent.

***ls\_detail.def\_data.ls\_role***

Link station role. This is normally set to AP\_USE\_PORT\_DEFAULTS, specifying that the LS role is taken from the definition of the port that owns this LS.

If the LS has been defined with a specific LS role overriding the port definition, this is one of the following values:

**AP\_LS\_PRI**

Primary

**AP\_LS\_SEC**

Secondary

**AP\_LS\_NEG**

Negotiable

***ls\_detail.def\_data.max\_ifrm\_rcvd***

Maximum of I-frames that can be received by this link station before an acknowledgment is sent. This value is in the range 0-127. When this field is zero, the value of *max\_ifrm\_rcvd* from DEFINE\_PORT is used as default.

***ls\_detail.def\_data.dlus\_retry\_timeout***

Interval in seconds between second and subsequent attempts to contact the DLUS specified in the *ls\_detail.def\_data.dlus\_name* and *ls\_detail.def\_data.bkup\_dlus\_name* parameters. The interval between the initial attempt and the first retry is always one second. If zero is returned, the default value configured with DEFINE\_DLUR\_DEFAULTS is used. This parameter is ignored if *ls\_detail.def\_data.dspu\_services* is not set to AP\_DLUR.

***ls\_detail.def\_data.dlus\_retry\_limit***

Maximum number of retries after an initial failure to contact the DLUS specified in the *ls\_detail.def\_data.dlus\_name* and *ls\_detail.def\_data.bkup\_dlus\_name* parameters. If zero is returned, the default value configured through DEFINE\_DLUR\_DEFAULTS is used. If 0x0FFFF is returned, CS/AIX retries indefinitely. This parameter is ignored if *ls\_detail.def\_data.dspu\_services* is not set to AP\_DLUR.

***def\_data.conventional\_lu\_compression***

Specifies whether data compression is requested for LU 0-3 sessions on this link. This parameter is used only if this link carries LU 0-3 traffic; it does not apply to LU 6.2 sessions.

Possible values are:

**AP\_YES**

Data compression should be used for LU 0-3 sessions on this link if the host requests it.

**AP\_NO**

Data compression should not be used for LU 0-3 sessions on this link.

***ls\_detail.def\_data.branch\_link\_type***

This parameter applies only if the local node is a Branch Network Node; it is reserved if the local node is any other type.

If the parameter *def\_data.adj\_cp\_type* is set to AP\_NETWORK\_NODE, AP\_END\_NODE, AP\_APPN\_NODE, or AP\_BACK\_LEVEL\_LEN\_NODE, this parameter defines whether the link is an uplink or a downlink.

Possible values are:

**AP\_UPLINK**

The link is an uplink.

**AP\_DOWNLINK**

The link is a downlink.

***ls\_detail.def\_data.adj\_brnn\_cp\_support***

This parameter applies only if the local node is a Branch Network Node and the adjacent node is a network node (the parameter *def\_data.adj\_cp\_type* is set to AP\_NETWORK\_NODE, or it is set to AP\_APPN\_NODE and the node type discovered during XID exchange is network node). It is reserved if the local and remote nodes are any other type.

This parameter defines whether the adjacent node can be a Branch Network Node that is acting as a Network Node from the point of view of the local node. Possible values are:

**AP\_BRNN\_ALLOWED**

The adjacent node is allowed (but not required) to be a Branch Network Node.

**AP\_BRNN\_REQUIRED**

The adjacent node must be a Branch Network Node.

**AP\_BRNN\_PROHIBITED**

The adjacent node must not be a Branch Network Node.

***ls\_detail.def\_data.pu\_can\_send\_dddllu\_offline***

Specifies whether the local PU should send NMVT (power off) messages to the host. If the host system supports DDDL (Dynamic Definition of Dependent LUs), CS/AIX sends NMVT (power off) to the host when it has finished using a dynamically defined LU. This allows the host to save resources by removing the definition when it is no longer required.

This parameter is used only if this link is to a host (*solicit\_sscp\_sessions* is set to AP\_YES and *dspu\_services* is not set to AP\_NONE).

Possible values are:

**AP\_YES**

The local PU sends NMVT (power off) messages to the host.

**AP\_NO**

The local PU does not send NMVT (power off) messages to the host.

If the host supports DDDL but does not support the NMVT (power off) message, this parameter must be set to AP\_NO.

***ls\_detail.def\_data.link\_spec\_data\_len***

Length of link-specific data that is passed unchanged to link station component during initialization. The data structure for this data follows the *ls\_def\_data* structure, but is padded to start on a 4-byte boundary. For more details of the link-specific data, see [“DEFINE\\_LS” on page 100](#).

**Returned parameters: parameter check**

If the verb does not execute because of a parameter error, CS/AIX returns the following parameters:

***primary\_rc***

AP\_PARAMETER\_CHECK

***secondary\_rc***

Possible values are:

**AP\_INVALID\_LINK\_NAME**

The *list\_options* parameter was set to AP\_LIST\_INCLUSIVE to list all entries starting from the supplied name, but the *ls\_name* parameter was not valid.

**AP\_INVALID\_LIST\_OPTION**

The *list\_options* parameter was not set to a valid value.

Appendix B, [“Common return codes,” on page 661](#) lists further secondary return codes associated with AP\_PARAMETER\_CHECK, which are common to all NOF verbs.

**Returned parameters: other conditions**

Appendix B, [“Common return codes,” on page 661](#) lists further combinations of primary and secondary return codes that are common to all NOF verbs.

**QUERY\_LS\_ROUTING**

The QUERY\_LS\_ROUTING verb returns information for local LUs about the location of a partner LU using a link station. If information is requested about more than one local LU, the information is returned based on the Management Information Base (MIB) order of the local LU names, then on the MIB order of partner LU names associated with each local LU name. Wildcard partner LU names can be interspersed with entries that do not contain wildcards.

**VCB structure**

```
typedef struct query_ls_routing
{
    AP_UINT16          opcode;                /* verb operation code          */
    unsigned char     reserv2;               /* reserved                      */
    unsigned char     format;               /* reserved                      */
    AP_UINT16          primary_rc;          /* primary return code          */
    AP_UINT32          secondary_rc;        /* secondary return code        */
    unsigned char     *buf_ptr;             /* buffer pointer               */
    AP_UINT32          buf_size;            /* buffer size                   */
    AP_UINT32          total_buf_size;      /* total buffer size            */
    AP_UINT16          num_entries;         /* number of entries            */
    AP_UINT16          total_num_entries;   /* total number of entries      */
    unsigned char     list_options;        /* list options                  */
    unsigned char     reserv3;             /* reserved                      */
    unsigned char     lu_name[8];          /* LU Name                      */
    unsigned char     lu_alias[8];        /* reserved                     */
    unsigned char     fq_partner_lu[17];   /* partner lu name              */
    unsigned char     wildcard_fqplu;     /* wildcard partner LU flag     */
    unsigned char     reserv4[2];         /* reserved                      */
} QUERY_LS_ROUTING;
```

```
typedef struct ls_routing_data
{
    AP_UINT16          overlay_size;
```

```

unsigned char    lu_name[8];           /* local LU name          */
unsigned char    lu_alias[8];         /* reserved               */
unsigned char    fq_partner_lu[17];   /* partner lu             */
unsigned char    wildcard_fqplu;      /* wildcard partner LU flag */
unsigned char    ls_name[8];         /* link to use            */
unsigned char    reserv3[2];         /* reserved               */
} LS_ROUTING_DATA;

```

## Supplied parameters

The application supplies the following parameters:

### **opcode**

AP\_QUERY\_LS\_ROUTING

### **num\_entries**

Maximum number of LS routing entries for which data should be returned. To request data for a specific LS rather than a range, specify the value 1. To return as many entries as possible, specify zero; in this case, CS/AIX will return the maximum number of entries that can be accommodated in the supplied data buffer.

### **list\_options**

The position in the list of LS routing entries from which CS/AIX begins to return data.

Specify one of the following values:

#### **AP\_FIRST\_IN\_LIST**

Start at the first entry in the list.

#### **AP\_LIST\_INCLUSIVE**

Start at the entry specified by the combination of the *lu\_name* and *fq\_partner\_lu* parameters.

#### **AP\_LIST\_FROM\_NEXT**

Start at the entry immediately following the entry specified by the combination of the *lu\_name*, *fq\_partner\_lu*, and *wildcard\_fqplu* parameters.

For more information about how the list is ordered and how the application can obtain specific entries from it, see [“List options for QUERY\\_\\* Verbs” on page 33](#).

### **lu\_name**

Name of the local LU, as defined to CS/AIX. This is an 8-byte type-A EBCDIC string, padded on the right with spaces if the name is shorter than eight bytes. This parameter is ignored if *list\_options* is set to AP\_FIRST\_IN\_LIST.

### **lu\_alias**

This parameter is reserved; set it to binary zeros.

### **fq\_partner\_lu**

Fully qualified name of the partner LU, as defined to CS/AIX. The name is a 17-byte EBCDIC string, padded on the right with EBCDIC spaces. This parameter is used to qualify the entry to return within the list of partner LU names for the specified local LU. This parameter is ignored if *list\_options* is set to AP\_FIRST\_IN\_LIST.

If this parameter is set to binary zeros and *list\_options* is set to AP\_LIST\_FROM\_NEXT, the returned list starts at the first partner LU name for the LU identified by the *lu\_name* parameter.

### **wildcard\_fqplu**

Wildcard partner LU flag indicating whether the *fq\_partner\_lu* parameter contains a full or partial wildcard. This flag is used only to identify the first record to return. It cannot be used to specify that only entries matching the wildcard specification are to be returned. Possible values are:

#### **AP\_YES**

The *fq\_partner\_lu* parameter contains a wildcard entry.

#### **AP\_NO**

The *fq\_partner\_lu* parameter does not contain a wildcard entry.



## Returned parameters: successful execution

If the verb executes successfully, CS/AIX returns the following parameters:

***primary\_rc***

AP\_OK

***lu\_name***

Name of the local LU.

***fq\_partner\_lu***

Fully qualified name of the partner LU.

***wildcard\_fqplu***

Flag indicating whether the *fq\_partner\_lu* parameter contains a full or partial wildcard. Possible values are:

**AP\_YES**

The *fq\_partner\_lu* parameter contains a full or partial wildcard.

**AP\_NO**

The *fq\_partner\_lu* parameter does not contain a full or partial wildcard.

***ls\_name***

Name of the link station used for sessions between the LU specified in the *lu\_name* parameter and the partner LU specified in the *fq\_plu\_name* parameter.

## Returned parameters: parameter check

If the verb does not execute because of a parameter error, CS/AIX returns the following parameters:

***primary\_rc***

AP\_PARAMETER\_CHECK

***secondary\_rc***

Possible values are:

**AP\_INVALID\_LU\_NAME**

The *list\_options* parameter was set to AP\_LIST\_INCLUSIVE, but the value specified for the *lu\_name* parameter did not match any existing LS routing data record.

**AP\_INVALID\_PARTNER\_LU\_NAME**

The *list\_options* parameter was set to AP\_LIST\_INCLUSIVE, but the value specified by the *fq\_partner\_lu* parameter did not match any existing LS routing data record for the specified partner LU name.

**AP\_INVALID\_WILDCARD\_NAME**

The *wildcard\_fqplu* parameter was set to AP\_YES, but the *fq\_partner\_lu* parameter was not a valid wildcard name.

**AP\_INVALID\_LIST\_OPTION**

The *list\_options* parameter was not set to a valid value.

Appendix B, "Common return codes," on page 661 lists further secondary return codes associated with AP\_PARAMETER\_CHECK, which are common to all NOF verbs.

## Returned parameters: other conditions

Appendix B, "Common return codes," on page 661 lists further combinations of primary and secondary return codes that are common to all NOF verbs.

## QUERY\_LU\_0\_TO\_3

QUERY\_LU\_0\_TO\_3 returns information about local LUs of type 0, 1, 2, or 3. This information is structured as "determined data" (data gathered dynamically during execution, returned only if the node is active) and "defined data" (the data supplied by the application on DEFINE\_LU\_0\_TO\_3).

This verb can be used to obtain either summary or detailed information, about a specific LU or about multiple LUs, depending on the options used.

## VCB structure

```
typedef struct query_lu_0_to_3
{
    AP_UINT16      opcode;                /* verb operation code          */
    unsigned char  reserv2;               /* reserved                      */
    unsigned char  format;               /* reserved                      */
    AP_UINT16      primary_rc;           /* primary return code          */
    AP_UINT32      secondary_rc;         /* secondary return code        */
    unsigned char  *buf_ptr;             /* pointer to buffer            */
    AP_UINT32      buf_size;             /* buffer size                  */
    AP_UINT32      total_buf_size;       /* total buffer size required   */
    AP_UINT16      num_entries;          /* number of entries            */
    AP_UINT16      total_num_entries;    /* total number of entries      */
    unsigned char  list_options;         /* listing options              */
    unsigned char  reserv3;             /* reserved                      */
    unsigned char  pu_name[8];          /* PU name filter               */
    unsigned char  lu_name[8];          /* LU name                      */
    unsigned char  host_attachment;      /* host attachment filter       */
} QUERY_LU_0_TO_3;
```

```
typedef struct lu_0_to_3_summary
{
    AP_UINT16      overlay_size;         /* size of returned entry       */
    unsigned char  pu_name[8];          /* PU name                      */
    unsigned char  lu_name[8];          /* LU name                      */
    unsigned char  description[32];     /* resource description         */
    unsigned char  reserv1[16];         /* reserved                      */
    unsigned char  nau_address;         /* NAU address                  */
    unsigned char  lu_sscp_sess_active; /* Is LU-SSCP session active   */
    unsigned char  appl_conn_active;    /* Is connection to appl active */
    unsigned char  plu_sess_active;     /* Is PLU-SLU session active    */
    unsigned char  host_attachment;     /* LU's host attachment         */
} LU_0_TO_3_SUMMARY;
```

```
typedef struct lu_0_to_3_detail
{
    AP_UINT16      overlay_size;         /* size of returned entry       */
    unsigned char  lu_name[8];          /* LU name                      */
    unsigned char  reserv1[2];         /* reserved                      */
    LU_0_TO_3_DET_DATA det_data;       /* Determined data              */
    LU_0_TO_3_DEF_DATA def_data;       /* Defined data                  */
} LU_0_TO_3_DETAIL;
```

```
typedef struct lu_0_to_3_det_data
{
    unsigned char  lu_sscp_sess_active; /* Is LU-SSCP session active   */
    unsigned char  appl_conn_active;    /* Application is using LU      */
    unsigned char  plu_sess_active;     /* Is PLU-SLU session active    */
    unsigned char  host_attachment;     /* Host attachment              */
    SESSION_STATS lu_sscp_stats;        /* reserved                      */
    SESSION_STATS plu_stats;           /* reserved                      */
    unsigned char  plu_name[8];         /* PLU name                    */
    unsigned char  session_id[8];       /* Internal ID of PLU-SLU sess  */
    unsigned char  app_spec_det_data[360]; /* Application specified data   */
    unsigned char  app_type;            /* Type of application using LU */
    unsigned char  sscp_id[6];         /* sscp id                      */
    unsigned char  bind_lu_type;        /* LU type from BIND message   */
    unsigned char  compression;        /* data compression level       */
    unsigned char  cryptography;        /* reserved                      */
    unsigned char  reserva[10];         /* reserved                      */
} LU_0_TO_3_DET_DATA;
```

```
typedef struct session_stats
{
    AP_UINT16      rcv_ru_size;         /* session receive RU size      */
    AP_UINT16      send_ru_size;        /* session send RU size         */
    AP_UINT16      max_send_btu_size;   /* maximum send BTU size        */
    AP_UINT16      max_rcv_btu_size;    /* maximum rcv BTU size         */
    AP_UINT16      max_send_pac_win;    /* maximum send pacing window size */
    AP_UINT16      cur_send_pac_win;    /* current send pacing window size */
    AP_UINT16      max_rcv_pac_win;     /* maximum receive pacing window */
}
```

```

        AP_UINT16      cur_rcv_pac_win;          /* size */
                                                /* current receive pacing window */
        AP_UINT32      send_data_frames;        /* size */
                                                /* number of data frames sent */
        AP_UINT32      send_fmd_data_frames;    /* num fmd data frames sent */
        AP_UINT32      send_data_bytes;        /* number of data bytes sent */
        AP_UINT32      rcv_data_frames;         /* number of data frames received */
        AP_UINT32      rcv_fmd_data_frames;     /* num fmd data frames received */
        AP_UINT32      rcv_data_bytes;         /* number of data bytes received */
        unsigned char  sidh;                    /* session ID high byte (from LFSID) */
        unsigned char  sidl;                    /* session ID low byte (from LFSID) */
        unsigned char  odai;                    /* ODAI bit set */
        unsigned char  ls_name[8];             /* Link station name */
        unsigned char  pacing_type;            /* type of pacing in use */
    } SESSION_STATS;

```

```

typedef struct lu_0_to_3_def_data
{
    unsigned char  description[32];            /* resource description */
    unsigned char  reserv1[16];                /* reserved */
    unsigned char  nau_address;                /* LU NAU address */
    unsigned char  pool_name[8];              /* LU Pool name */
    unsigned char  pu_name[8];                /* PU name */
    unsigned char  priority;                   /* LU priority */
    unsigned char  lu_model;                   /* LU model (type) */
    unsigned char  sscp_id[6];                /* SSCP ID */
    AP_UINT16      timeout;                    /* Timeout */
    unsigned char  app_spec_def_data[16];     /* application-specified data */
    unsigned char  model_name[7];             /* reserved */
    unsigned char  term_method;                /* session termination type */
    unsigned char  disconnect_on_unbind;      /* disconnect on UNBIND flag */
    unsigned char  reserv3[15];                /* reserved */
} LU_0_TO_3_DEF_DATA;

```

If the *app\_type* parameter in the *lu\_0\_to\_3\_det\_data* structure is set to *AP\_LUA\_APPLICATION*, the *app\_spec\_det\_data* field contains the following structure:

```

typedef struct lua_session_user_info
{
    unsigned char  user_ip_address[40];        /* IP address of LUA application */
    unsigned char  user_host_address[256];    /* Host name of LUA application */
    unsigned char  reserved[24];              /* reserved */
} SESSION_USER_INFO;

```

If the *app\_type* parameter in the *lu\_0\_to\_3\_det\_data* structure is set to *AP\_FMI\_APPLICATION*, the *app\_spec\_det\_data* field contains the following structure:

```

typedef struct session_user_info
{
    unsigned char  user_name[32];              /* 3270 user name */
    unsigned char  system_name[128];          /* computer name */
    AP_UINT32      user_pid;                   /* process ID */
    AP_UINT32      user_type;                  /* type of application using LU */
    AP_UINT32      user_uid;                   /* user ID */
    AP_UINT32      user_gid;                   /* group ID */
    unsigned char  user_gname[32];            /* group name */
    unsigned char  reserv4[32];                /* reserved */
} SESSION_USER_INFO;

```

If the *app\_type* parameter in the *lu\_0\_to\_3\_det\_data* structure is set to *AP\_PU\_CONCENTRATION*, the *app\_spec\_det\_data* field contains the same structure as the 3270 structure above except that the *app\_type* parameter is set to *AP\_PU\_CONCENTRATION* and the *user\_name* through *user\_gname* parameters are replaced by a *pu\_conc\_downstream\_lu* parameter.

If the *app\_type* parameter in the *lu\_0\_to\_3\_det\_data* structure is set to *AP\_LUA\_APPLICATION*, the *app\_spec\_det\_data* field contains the same structure as the 3270 structure above except that the *app\_type* parameter is set to *AP\_LUA\_APPLICATION* and the *user\_name* through *user\_gname* parameters are not returned.

If the *app\_type* parameter in the *lu\_0\_to\_3\_det\_data* structure is set to *AP\_TN\_SERVER*, the *app\_spec\_det\_data* field contains the following structure:

```
typedef struct tn_server_session_user_info
{
    unsigned char    user_ip_address[40];    /* user's IP address          */
    AP_UINT16        port_number;           /* TCP/IP port number        */
    AP_UINT16        cb_number;             /* reserved                   */
    AP_UINT16        cfg_default;           /* using the default record?  */
    unsigned char    cfg_address[68];       /* address from config record */
    AP_UINT16        cfg_format;            /* format of address          */
    unsigned char    tn3270_level;          /* TN3270 level used:         */
                                                /* AP_LEVEL_TN3270            */
                                                /* AP_LEVEL_TN3270E          */
    unsigned char    lu_select;              /* method of LU selection:   */
                                                /* AP_GENERIC_LU              */
                                                /* AP_SPECIFIC_LU            */
                                                /* AP_ASSOCIATED_LU          */
    unsigned char    request_lu_name[8];    /* requested LU name or      */
                                                /* associated display LU name */
                                                /* (in EBCDIC)                */
    unsigned char    cipher_spec;           /* SSL cipher specification   */
    unsigned char    reserv3[21];           /* reserved                   */
} TN_SERVER_SESSION_USER_INFO;
```

## Supplied parameters

The application supplies the following parameters:

### ***opcode***

AP\_QUERY\_LU\_0\_TO\_3

### ***buf\_ptr***

A pointer to a data buffer that CS/AIX will use to return the requested information.

### ***buf\_size***

Size of the supplied data buffer.

### ***num\_entries***

Maximum number of LUs for which data should be returned. To request data for a specific LU rather than a range, specify the value 1. To return as many entries as possible, specify 0; in this case, CS/AIX will return the maximum number of entries that can be accommodated in the supplied data buffer.

### ***list\_options***

The position in the list from which CS/AIX should begin to return data, and the level of information required for each entry. Specify the level of information with one of the following values:

#### **AP\_SUMMARY**

Summary information only.

#### **AP\_DETAIL**

Detailed information.

Combine this value using a logical OR operation with one of the following values:

#### **AP\_FIRST\_IN\_LIST**

Start at the first entry in the list.

#### **AP\_LIST\_INCLUSIVE**

Start at the entry specified by the *lu\_name* parameter.

#### **AP\_LIST\_FROM\_NEXT**

Start at the entry immediately following the entry specified by the *lu\_name* parameter.

For more information about how the list is ordered and how the application can obtain specific entries from it, see [“List options for QUERY\\_\\* Verbs” on page 33](#).

### ***pu\_name***

PU name for which LU information is required. To list only information about LUs associated with a specific PU, specify the PU name. To obtain a complete list for all PUs, set this field to binary zeros.

**lu\_name**

Name of the local LU. This is an 8-byte type-A EBCDIC string (starting with a letter), padded on the right with EBCDIC spaces if the name is shorter than 8 characters. This parameter is ignored if *list\_options* is set to AP\_FIRST\_IN\_LIST.

**host\_attachment**

Host attachment filter. If the verb is issued to a running node, this parameter specifies whether to filter the returned information by whether the LUs are attached to the host directly or using DLUR or PU Concentration. Possible values are:

**AP\_DIRECT\_ATTACHED**

Return information only on LUs directly attached to the host system.

**AP\_DLUR\_ATTACHED**

Return information only on LUs supported by DLUR on the local node.

**AP\_DLUR**

Return information only on LUs supported by passthrough DLUR from a downstream node. This option is valid only if the local node is a Network Node.

**AP\_PU\_CONCENTRATION**

Return information only on LUs supported by SNA gateway from a downstream node.

**AP\_NONE**

Return information about all LUs regardless of host attachment.

If the node is not running, this parameter is ignored; CS/AIX returns information about all LUs regardless of host attachment.

## Returned parameters: successful execution

If the verb executes successfully, CS/AIX returns the following parameters:

**primary\_rc**

AP\_OK

**buf\_size**

Length of the information returned in the supplied buffer.

**total\_buf\_size**

Returned value indicating the size of buffer that would have been required to return all the list information requested. A value greater than *buf\_size* indicates that not all the available entries were returned.

**num\_entries**

Number of entries returned in the data buffer.

**total\_num\_entries**

Total number of entries available. A value greater than *num\_entries* indicates that not all the available entries were returned.

Each entry in the data buffer consists of the following parameters:

**lu\_0\_to\_3\_summary.overlay\_size**

The size of the returned *lu\_0\_to\_3\_summary* structure, and therefore the offset to the start of the next entry in the data buffer.

When your application needs to go through the returned buffer to find each *lu\_0\_to\_3\_summary* structure in turn, it must use this value to move to the correct offset for the next data structure, and must not use the C `sizeof()` operator. This is because the size of the returned overlay may increase in future releases of CS/AIX; using the returned overlay size ensures that your application will continue to work with future releases.

**lu\_0\_to\_3\_summary.pu\_name**

Name of the local PU used by the LU. This is an 8-byte type-A EBCDIC string (starting with a letter), padded on the right with EBCDIC spaces if the name is shorter than 8 characters.

***lu\_0\_to\_3\_summary.lu\_name***

Name of the local LU. This is an 8-byte type-A EBCDIC string (starting with a letter), padded on the right with EBCDIC spaces if the name is shorter than 8 characters.

***lu\_0\_to\_3\_summary.description***

A null-terminated text string describing the LU, as specified in the definition of the LU.

***lu\_0\_to\_3\_summary.nau\_address***

Network accessible unit address of the LU. This is in the range 1-255.

***lu\_0\_to\_3\_summary.lu\_sscp\_sess\_active***

Specifies whether the LU-SSCP session is active. Possible values are:

**AP\_YES**

The session is active.

**AP\_NO**

The session is inactive.

***lu\_0\_to\_3\_summary.appl\_conn\_active***

Specifies whether an application is using the LU. Possible values are:

**AP\_YES**

An application is using the LU.

**AP\_NO**

No application is using the LU.

***lu\_0\_to\_3\_summary.plu\_sess\_active***

Specifies whether the PLU-SLU session is active. Possible values are:

**AP\_YES**

The session is active.

**AP\_NO**

The session is inactive.

***lu\_0\_to\_3\_summary.host\_attachment***

LU host attachment type.

When the verb is issued to a running node, this parameter takes one of the following values:

**AP\_DIRECT\_ATTACHED**

LU is directly attached to the host system.

**AP\_DLUR\_ATTACHED**

LU is supported by DLUR on the local node.

**AP\_DLUR**

LU is supported by passthrough DLUR from a downstream node.

**AP\_PU\_CONCENTRATION**

LU is supported by SNA gateway from a downstream node.

***lu\_0\_to\_3\_detail.overlay\_size***

The size of the returned `lu_0_to_3_detail` structure, and therefore the offset to the start of the next entry in the data buffer.

When your application needs to go through the returned buffer to find each `lu_0_to_3_detail` structure in turn, it must use this value to move to the correct offset for the next data structure, and must not use the C `sizeof()` operator. This is because the size of the returned overlay may increase in future releases of CS/AIX; using the returned overlay size ensures that your application will continue to work with future releases.

***lu\_0\_to\_3\_detail.lu\_name***

Name of the local LU. This is an 8-byte type-A EBCDIC string (starting with a letter), padded on the right with EBCDIC spaces if the name is shorter than 8 characters.

***lu\_0\_to\_3\_detail.det\_data.lu\_sscp\_sess\_active***

Specifies whether the LU-SSCP session is active. Possible values are:

**AP\_YES**

The session is active.

**AP\_NO**

The session is inactive.

***lu\_0\_to\_3\_detail.det\_data.appl\_conn\_active***

Specifies whether an application is using the LU. Possible values are:

**AP\_YES**

An application is using the LU.

**AP\_NO**

No application is using the LU.

***lu\_0\_to\_3\_detail.det\_data.plu\_sess\_active***

Specifies whether the PLU-SLU session is active. Possible values are:

**AP\_YES**

The session is active.

**AP\_NO**

The session is inactive.

***lu\_0\_to\_3\_detail.det\_data.host\_attachment***

LU host attachment type.

When the verb is issued to a running node, this parameter takes one of the following values:

**AP\_DIRECT\_ATTACHED**

LU is directly attached to the host system.

**AP\_DLUR\_ATTACHED**

LU is supported by DLUR on the local node.

**AP\_DLUR**

LU is supported by passthrough DLUR from a downstream node.

**AP\_PU\_CONCENTRATION**

LU is supported by SNA gateway from a downstream node.

For each of the two sessions (LU-SSCP session and PLU-SLU session), the `session_stats` structure contains the following parameters:

***rcv\_ru\_size***

Maximum receive RU size. (In the LU-SSCP session statistics, this parameter is reserved.)

***send\_ru\_size***

Maximum send RU size. (In the LU-SSCP session statistics, this parameter is reserved.)

***max\_send\_btu\_size***

Maximum BTU size that can be sent.

***max\_rcv\_btu\_size***

Maximum BTU size that can be received.

***max\_send\_pac\_win***

Maximum size of the send pacing window on this session. (In the LU-SSCP session statistics, this parameter is reserved.)

***cur\_send\_pac\_win***

Current size of the send pacing window on this session. (In the LU-SSCP session statistics, this parameter is reserved.)

***max\_rcv\_pac\_win***

Maximum size of the receive pacing window on this session. (In the LU-SSCP session statistics, this parameter is reserved.)

***cur\_rcv\_pac\_win***

Current size of the receive pacing window on this session. (In the LU-SSCP session statistics, this parameter is reserved.)

***send\_data\_frames***

Number of normal flow data frames sent.

***send\_fmd\_data\_frames***

Number of normal flow FMD data frames sent.

***send\_data\_bytes***

Number of normal flow data bytes sent.

***rcv\_data\_frames***

Number of normal flow data frames received.

***rcv\_fmd\_data\_frames***

Number of normal flow FMD data frames received.

***rcv\_data\_bytes***

Number of normal flow data bytes received.

***sidh***

Session ID high byte.

***sidl***

Session ID low byte.

***odai***

Origin Destination Assignor Indicator. When bringing up a session, the sender of the BIND sets this field to zero if the local node contains the primary link station, and sets it to one if the BIND sender is the node containing the secondary link station.

***ls\_name***

Link station name associated with statistics. This is an 8-byte ASCII character string, right-padded with spaces if the name is shorter than 8 characters.

***pacing\_type***

Receive pacing type in use on the PLU-SLU session. Possible values are:

- AP\_NONE
- AP\_PACING\_FIXED

***lu\_0\_to\_3\_detail.det\_data.plu\_name***

Name of the primary LU. This is an 8-byte type-A EBCDIC string, right-padded with spaces if the name is shorter than 8 characters. This name is reserved if the PLU-SLU session is inactive.

***lu\_0\_to\_3\_detail.det\_data.session\_id***

Eight byte internal identifier of the PLU-SLU session.

***lu\_0\_to\_3\_detail.det\_data.app\_spec\_det\_data***

The format of the data in this field depends on the value of the *app\_type* field below, as follows:

- If *app\_type* is set to AP\_NONE, this field is reserved.
- If *app\_type* is set to AP\_PU\_CONCENTRATION, the first 8 bytes of this field contain the LU name of the downstream LU currently using this local LU. This is an EBCDIC string, right-padded with spaces if the name is shorter than 8 characters. The remaining bytes are reserved.
- If *app\_type* is set to AP\_LUA\_APPLICATION, this field is replaced by the *lua\_session\_user\_info* structure, as described below.
- If *app\_type* is set to AP\_FMI\_APPLICATION, this field is replaced by the *session\_user\_info* structure, as described below.

If *app\_type* is set to AP\_LUA\_APPLICATION, the *app\_spec\_det\_data* field is replaced by the *lua\_session\_user\_info* structure, containing information about the LUA application using this LU. The structure consists of the following fields:

***user\_ip\_address***

The IP address of the computer (client or server) where the LUA application is running. This is a null-terminated ASCII string, which can be either of the following.

- An IPv4 dotted-decimal address (such as 193 . 1 . 11 . 100).



- An IPv6 colon-hexadecimal address (such as 2001:0db8:0000:0000:0000:0000:1428:57ab or 2001:db8::1428:57ab).

**user\_host\_address**

The name of the computer (client or server) where the LUA application is running. This is a null-terminated ASCII string, representing an IP hostname (such as newbox.this.co.uk).

If *app\_type* is set to AP\_FMI\_APPLICATION, the *app\_spec\_det\_datafield* is replaced by the *session\_user\_info* structure, containing information about the user of this LU. The structure consists of the following fields:

**user\_name**

The AIX user name with which the 3270 emulation program using this LU is running. This is an ASCII string of 1-32 characters.

**system\_name**

The computer name on which the program is running.

**user\_pid**

The process ID of the program using the LU.

**user\_type**

The type of session (3270 display session, 3270 printer session) using the LU. Possible values are:

AP\_3270\_DISPLAY\_MODEL\_2  
 AP\_3270\_DISPLAY\_MODEL\_3  
 AP\_3270\_DISPLAY\_MODEL\_4  
 AP\_3270\_DISPLAY\_MODEL\_5  
 AP\_PRINTER  
 AP\_SCS\_PRINTER  
 AP\_UNKNOWN

**user\_uid**

The AIX user ID with which the program is running.

**user\_gid**

The AIX group ID with which the program is running.

**user\_gname**

The AIX group name with which the program is running. This is an ASCII string of 1-32 characters.

If *app\_type* is set to AP\_TN\_SERVER, this field is replaced by the *tn\_server\_session\_user\_info* structure, containing information about the TN3270 program that is using this LU. The structure consists of the following fields:

**user\_ip\_address**

The IP address of the computer where the TN3270 program is running. This is a null-terminated ASCII string, which can be either of the following.

- An IPv4 dotted-decimal address (such as 193.1.11.100).
- An IPv6 colon-hexadecimal address (such as 2001:0db8:0000:0000:0000:0000:1428:57ab or 2001:db8::1428:57ab).

**port\_number**

The TCP/IP port number that the TN3270 program uses to access TN server.

**cb\_number**

TN server control block number.

**cfg\_default**

Specifies whether the TN3270 program is using an explicitly-defined TN server user record, or is using the configured default record. For more information about configuring a default TN server user record, see [“DEFINE\\_TN3270\\_ACCESS” on page 179](#). Possible values are:

**AP\_YES**

The program is using the default record. The *cfg\_address* and *cfg\_format* parameters below are reserved.

**AP\_NO**

The program is using an explicitly-defined record.

***cfg\_address***

The TCP/IP address of the computer on which the TN3270 program runs, as defined in the configuration record that this user is using. This can be any of the following; the format is indicated by the *cfg\_format* parameter.

- An IPv4 dotted-decimal address (such as 193.1.11.100).
- An IPv6 colon-hexadecimal address (such as 2001:0db8:0000:0000:0000:1428:57ab or 2001:db8::1428:57ab).
- A name (such as newbox.this.co.uk).
- An alias (such as newbox).

***cfg\_format***

Specifies the format of the *cfg\_address* parameter. Possible values are:

**AP\_ADDRESS\_IP**

IP address

**AP\_ADDRESS\_FQN**

Alias or fully qualified name

***tn3270\_level***

Level of TN3270 support. Possible values are:

**AP\_LEVEL\_TN3270**

TN3270E protocols are disabled.

**AP\_LEVEL\_TN3270E**

TN3270E protocols are enabled.

***lu\_select***

Method of LU selection. Possible values are:

**AP\_GENERIC\_LU**

The TN3270 program selected a generic display or printer LU.

**AP\_SPECIFIC\_LU**

The TN3270 program selected this LU specifically.

**AP\_ASSOCIATED\_LU**

This is a printer LU that has been associated with a display LU by a DEFINE\_TN3270\_ASSOCIATION verb, or a display LU that has been associated with a printer LU by a DEFINE\_TN3270\_ASSOCIATION verb. The LU is in use by the TN3270 through its association.

***request\_lu\_name***

Requested LU name or associated display LU name. This is an 8-byte type-A EBCDIC string, padded on the right with spaces if the name is shorter than 8 characters.

***cipher\_spec***

Indicates the type of SSL security and the encryption level in use for this session. Possible values are:

**AP\_SSL\_NO\_SSL**

SSL is not being used.

**AP\_TLS\_RSA\_WITH\_NULL\_NULL AP\_TLS\_RSA\_WITH\_NULL\_SHA AP\_TLS\_RSA\_WITH\_NULL\_MD5**

Certificates are exchanged, but no encryption is used.

**AP\_TLS\_RSA\_WITH\_DES\_CBC\_SHA**

DES 56-bit encryption (deprecated).

**AP\_TLS\_AES\_128\_CCM\_8\_SHA256** **AP\_TLS\_AES\_128\_CCM\_SHA256**  
**AP\_TLS\_AES\_128\_GCM\_SHA256** **AP\_TLS\_ECDHE\_ECDSA\_WITH\_AES\_128\_CBC\_SHA**  
**AP\_TLS\_ECDHE\_ECDSA\_WITH\_AES\_128\_CBC\_SHA256**  
**AP\_TLS\_ECDHE\_ECDSA\_WITH\_AES\_128\_GCM\_SHA256**  
**AP\_TLS\_ECDHE\_RSA\_WITH\_AES\_128\_CBC\_SHA**  
**AP\_TLS\_ECDHE\_RSA\_WITH\_AES\_128\_CBC\_SHA256**  
**AP\_TLS\_ECDHE\_RSA\_WITH\_AES\_128\_GCM\_SHA256** **AP\_TLS\_RSA\_WITH\_AES\_128\_CBC\_SHA**  
**AP\_TLS\_RSA\_WITH\_AES\_128\_CBC\_SHA256** **AP\_TLS\_RSA\_WITH\_AES\_128\_GCM\_SHA256**  
 128-bit encryption.

**AP\_TLS\_ECDHE\_ECDSA\_WITH\_3DES\_EDE\_CBC\_SHA**  
**AP\_TLS\_ECDHE\_RSA\_WITH\_3DES\_EDE\_CBC\_SHA** **AP\_TLS\_RSA\_WITH\_3DES\_EDE\_CBC\_SHA**  
 Triple-DES 168-bit encryption.

**AP\_TLS\_AES\_256\_GCM\_SHA384** **AP\_TLS\_ECDHE\_ECDSA\_WITH\_AES\_256\_CBC\_SHA**  
**AP\_TLS\_ECDHE\_ECDSA\_WITH\_AES\_256\_CBC\_SHA384**  
**AP\_TLS\_ECDHE\_ECDSA\_WITH\_AES\_256\_GCM\_SHA384**  
**AP\_TLS\_ECDHE\_RSA\_WITH\_AES\_256\_CBC\_SHA**  
**AP\_TLS\_ECDHE\_RSA\_WITH\_AES\_256\_CBC\_SHA384**  
**AP\_TLS\_ECDHE\_RSA\_WITH\_AES\_256\_GCM\_SHA384** **AP\_TLS\_RSA\_WITH\_AES\_256\_CBC\_SHA**  
**AP\_TLS\_RSA\_WITH\_AES\_256\_CBC\_SHA256** **AP\_TLS\_RSA\_WITH\_AES\_256\_GCM\_SHA384**  
**AP\_TLS\_CHACHA20\_POLY1305\_SHA256**  
 256-bit encryption (recommended).

#### ***lu\_0\_to\_3\_detail.det\_data.app\_type***

The type of application, if any, that is using the LU. Possible values are:

##### **AP\_NONE**

The LU is not in use.

##### **AP\_LUA\_APPLICATION**

The LU is being used by an LUA application.

##### **AP\_PU\_CONCENTRATION**

The LU is being used by a downstream LU using SNA gateway.

##### **AP\_FMI\_APPLICATION**

The LU is being used by a 3270 emulation program.

##### **AP\_TN\_SERVER**

The LU is being used by a TN3270 program accessing TN server.

#### ***lu\_0\_to\_3\_detail.det\_data.sscp\_id***

A 6-byte field containing the SSCP ID received in the ACTPU for the PU used by this LU. If *lu\_sscp\_sess\_active* is AP\_NO, this parameter will be all zeros.

#### ***lu\_0\_to\_3\_detail.det\_data.bind\_lu\_type***

Specifies the LU type of the LU which issued the original BIND (if there is an active LU-LU session). Possible values are:

##### **AP\_LU\_TYPE\_0**

LU type 0.

##### **AP\_LU\_TYPE\_1**

LU type 1.

##### **AP\_LU\_TYPE\_2**

LU type 2.

##### **AP\_LU\_TYPE\_3**

LU type 3.

##### **AP\_LU\_TYPE\_6**

Downstream dependent LU 6.2.

##### **AP\_LU\_TYPE\_UNKNOWN**

There is no active LU-LU session.

***lu\_0\_to\_3\_detail.def\_data.compression***

Compression level in use on the PLU-SLU session, if any. Possible values are:

**AP\_NO**

Data flowing on the PLU-SLU session is not compressed by CS/AIX, or there is no active PLU-SLU session.

**AP\_YES**

CS/AIX performs compression and decompression on PLU-SLU session data. RLE compression is used on data flowing upstream to the primary LU, and LZ9 compression is used on data flowing downstream from the primary LU.

**AP\_PASSTHRU**

Compression on this session is performed by the session endpoints (the host LU and the local application or downstream LU), and not by CS/AIX.

***lu\_0\_to\_3\_detail.def\_data.description***

A null-terminated text string describing the LU, as specified in the definition of the LU.

***lu\_0\_to\_3\_detail.def\_data.nau\_address***

Network accessible unit address of the LU, in the range 1-255.

***lu\_0\_to\_3\_detail.def\_data.pool\_name***

Name of the LU pool to which this LU belongs. This is an 8-byte EBCDIC string, padded on the right with spaces if the name is shorter than 8 characters. If the LU does not belong to a pool, this field is set to 8 binary zeros.

***lu\_0\_to\_3\_detail.def\_data.pu\_name***

Name of the PU (as specified on the DEFINE\_LS verb) which this LU will use. This is an 8-byte type-A EBCDIC string, padded on the right with spaces if the name is shorter than 8 characters.

***lu\_0\_to\_3\_detail.def\_data.priority***

LU priority when sending to the host. This is set to one of the following:

- AP\_NETWORK
- AP\_HIGH
- AP\_MEDIUM
- AP\_LOW

***lu\_0\_to\_3\_detail.def\_data.lu\_model***

Type of the LU. This is set to one of the following:

- AP\_3270\_DISPLAY\_MODEL\_2
- AP\_3270\_DISPLAY\_MODEL\_3
- AP\_3270\_DISPLAY\_MODEL\_4
- AP\_3270\_DISPLAY\_MODEL\_5
- AP\_PRINTER
- AP\_SCS\_PRINTER
- AP\_UNKNOWN

***lu\_0\_to\_3\_detail.def\_data.sscp\_id***

Specifies the ID of the SSCP permitted to activate this LU. This is a 6-byte binary field. If this parameter is set to binary zeros, the LU may be activated by any SSCP.

***lu\_0\_to\_3\_detail.def\_data.timeout***

Timeout for the LU, specified in seconds. If a timeout is supplied and the user of the LU specified allow\_timeout on the OPEN\_LU\_SSCP\_SEC\_RQ (or, in the case of SNA gateway, on the downstream LU definition), then the LU will be deactivated after the PLU-SLU session is left inactive for this period and one of the following conditions applies:

- The session passes over a limited resource link.
- Another application wishes to use the LU before the session is used again.

If the timeout is set to zero, the LU will not be deactivated.

#### ***lu\_0\_to\_3\_detail.def\_data.term\_method***

This parameter specifies how CS/AIX should attempt to end a PLU-SLU session to a host from this LU. Possible values are:

##### **AP\_USE\_NODE\_DEFAULT**

Use the node's default termination method, specified by the *send\_term\_self* parameter on DEFINE\_NODE.

##### **AP\_SEND\_UNBIND**

End the session by sending an UNBIND.

##### **AP\_SEND\_TERM\_SELF**

End the session by sending a TERM\_SELF.

#### ***lu\_0\_to\_3\_detail.def\_data.disconnect\_on\_unbind***

This parameter applies only when this LU is being used by a TN3270 client. It specifies whether to end the session when the host sends an UNBIND instead of displaying the VTAM MSG10 or returning to a host session manager. Possible values are:

##### **AP\_YES**

End the session if the host sends an UNBIND that is not type 2 (BIND forthcoming).

##### **AP\_NO**

Do not end the session if the host sends an UNBIND.

## Returned parameters: parameter check

If the verb does not execute because of a parameter error, CS/AIX returns the following parameters:

#### ***primary\_rc***

AP\_PARAMETER\_CHECK

#### ***secondary\_rc***

Possible values are:

##### **AP\_INVALID\_LU\_NAME**

The *list\_options* parameter was set to AP\_LIST\_INCLUSIVE to list all entries starting from the supplied name, but the *lu\_name* parameter was not valid.

##### **AP\_INVALID\_LIST\_OPTION**

The *list\_options* parameter was not set to a valid value.

Appendix B, “Common return codes,” on page 661 lists further secondary return codes associated with AP\_PARAMETER\_CHECK, which are common to all NOF verbs.

## Returned parameters: other conditions

Appendix B, “Common return codes,” on page 661 lists further combinations of primary and secondary return codes that are common to all NOF verbs.

## QUERY\_LU\_LU\_PASSWORD

QUERY\_LU\_LU\_PASSWORD returns information about passwords used for session-level security verification between a local LU and a partner LU. It can be used to obtain information about the password for a specific partner LU or about passwords for multiple partner LUs, depending on the options used.

## VCB structure

```
typedef struct query_lu_lu_password
{
    AP_UINT16      opcode;                /* Verb operation code          */
    unsigned char  reserv2;              /* reserved                      */
    unsigned char  format;               /* reserved                      */
    AP_UINT16      primary_rc;          /* Primary return code          */
}
```

## QUERY\_LU\_LU\_PASSWORD

```
AP_UINT32      secondary_rc;          /* Secondary return code */
unsigned char  *buf_ptr;              /* pointer to buffer      */
AP_UINT32      buf_size;              /* buffer size            */
AP_UINT32      total_buf_size;        /* total buffer size required */
AP_UINT16      num_entries;           /* number of entries      */
AP_UINT16      total_num_entries;     /* total number of entries */
unsigned char  list_options;          /* listing options        */
unsigned char  reserv3;               /* reserved                */
unsigned char  lu_name[8];            /* LU name                 */
unsigned char  lu_alias[8];           /* LU alias                 */
unsigned char  plu_alias[8];          /* partner LU alias        */
unsigned char  fqplu_name[17];        /* fully-qual. partner LU name */
} QUERY_LU_LU_PASSWORD;
```

```
typedef struct password_info
{
    AP_UINT16      overlay_size;        /* size of returned entry */
    unsigned char  plu_alias[8];        /* partner LU alias        */
    unsigned char  fqplu_name[17];     /* fully-qual. partner LU name */
    unsigned char  description[32];     /* resource description    */
    unsigned char  reserv1[16];        /* reserved                 */
    unsigned char  password[8];        /* password                 */
    unsigned char  protocol_defined;   /* protocol defined        */
    unsigned char  protocol_in_use;    /* protocol in use         */
} PASSWORD_INFO;
```

## Supplied parameters

The application supplies the following parameters:

### ***opcode***

AP\_QUERY\_LU\_LU\_PASSWORD

### ***buf\_ptr***

A pointer to a data buffer that CS/AIX will use to return the requested information.

### ***buf\_size***

Size of the supplied data buffer.

### ***num\_entries***

Maximum number of partner LUs for which password information should be returned. To request a specific entry rather than a range, specify the value 1. To return as many entries as possible, specify zero; in this case, CS/AIX will return the maximum number of entries that can be accommodated in the supplied data buffer.

### ***list\_options***

The position in the list from which CS/AIX should begin to return data. Specify one of the following values:

#### **AP\_FIRST\_IN\_LIST**

Start at the first entry in the list.

#### **AP\_LIST\_INCLUSIVE**

Start at the entry specified by the *plu\_alias* or *fqplu\_name* parameter.

#### **AP\_LIST\_FROM\_NEXT**

Start at the entry immediately following the entry specified by the *plu\_alias* or *fqplu\_name* parameter.

For more information about how the list is ordered and how the application can obtain specific entries from it, see [“List options for QUERY\\_\\* Verbs” on page 33](#).

### ***lu\_name***

LU name. This name is an 8-byte type-A EBCDIC character string. To indicate that the LU is identified by its LU alias instead of its LU name, set this parameter to 8 binary zeros, and specify the LU alias in the *lu\_alias* parameter.

***lu\_alias***

Locally defined LU alias. This is an 8-byte ASCII character string. This parameter is used only if *lu\_name* is set to all zeros; it is ignored otherwise. To indicate the LU associated with the CP (the default LU), set both *lu\_name* and *lu\_alias* to all zeros.

***plu\_alias***

Partner LU alias. This is an 8-byte ASCII character string. If *list\_options* is set to AP\_FIRST\_IN\_LIST, this parameter is ignored; otherwise you must specify either the LU alias or the fully qualified LU name for the partner LU. To indicate that the partner LU is identified by its fully qualified LU name instead of its LU alias, set this parameter to 8 binary zeros, and specify the LU alias in the *fqplu\_name* parameter.

***fqplu\_name***

Fully qualified network name for the partner LU. If *list\_options* is set to AP\_FIRST\_IN\_LIST, this parameter is ignored; otherwise you must specify either the LU alias or the fully qualified LU name for the partner LU. This parameter is used only if *plu\_alias* is set to all zeros; it is ignored otherwise.

The name is a 17-byte EBCDIC string, right-padded with EBCDIC spaces. It consists of a network ID of up to 8 A-string characters, an EBCDIC dot (period) character, and a network name of up to 8 A-string characters.

## Returned parameters: successful execution

If the verb executes successfully, CS/AIX returns the following parameters:

***primary\_rc***

AP\_OK

***buf\_size***

Length of the information returned in the supplied buffer.

***total\_buf\_size***

Returned value indicating the size of buffer that would have been required to return all the list information requested. A value greater than *buf\_size* indicates that not all the available entries were returned.

***num\_entries***

Number of entries returned in the data buffer.

***total\_num\_entries***

Total number of entries available. A value greater than *num\_entries* indicates that not all the available entries were returned.

Each entry in the data buffer consists of the following parameters:

***password\_info.overlay\_size***

The size of the returned *password\_info* structure, and therefore the offset to the start of the next entry in the data buffer.

When your application needs to go through the returned buffer to find each *password\_info* structure in turn, it must use this value to move to the correct offset for the next data structure, and must not use the C `sizeof()` operator. This is because the size of the returned overlay may increase in future releases of CS/AIX; using the returned overlay size ensures that your application will continue to work with future releases.

***password\_info.plu\_alias***

Partner LU alias. This is an 8-byte ASCII character string.

***password\_info.fqplu\_name***

Fully qualified network name for the partner LU. The name is a 17-byte EBCDIC string, right-padded with EBCDIC spaces. It consists of a network ID of up to 8 A-string characters, an EBCDIC dot (period) character, and a network name of up to 8 A-string characters.

***password\_info.description***

A null-terminated text string describing the LU-LU password, as specified in the definition of the password.

## QUERY\_LU\_POOL

### ***password\_info.password***

An encrypted version of the password supplied on a DEFINE\_LU\_LU\_PASSWORD verb. This is an 8-byte hexadecimal string.

### ***password\_info.protocol\_defined***

Requested LU-LU verification protocol defined for use with this partner LU. Possible values are:

#### **AP\_BASIC**

Basic security protocols requested.

#### **AP\_ENHANCED**

Enhanced security protocols requested.

#### **AP\_EITHER**

Basic or enhanced security accepted.

### ***password\_info.protocol\_in\_use***

LU-LU verification protocol in use with this partner LU. Possible values are:

#### **AP\_BASIC**

Basic security protocols in use.

#### **AP\_ENHANCED**

Enhanced security protocols in use.

## Returned parameters: parameter check

If the verb does not execute because of a parameter error, CS/AIX returns the following parameters:

### ***primary\_rc***

AP\_PARAMETER\_CHECK

### ***secondary\_rc***

Possible values are:

#### **AP\_INVALID\_LU\_ALIAS**

The supplied *lu\_alias* parameter did not match the alias of any configured LU.

#### **AP\_INVALID\_LU\_NAME**

The supplied *lu\_name* parameter did not match the name of any configured LU.

#### **AP\_INVALID\_LIST\_OPTION**

The *list\_options* parameter was not set to a valid value.

Appendix B, “Common return codes,” on page 661 lists further secondary return codes associated with AP\_PARAMETER\_CHECK, which are common to all NOF verbs.

## Returned parameters: other conditions

Appendix B, “Common return codes,” on page 661 lists further combinations of primary and secondary return codes that are common to all NOF verbs.

## QUERY\_LU\_POOL

---

QUERY\_LU\_POOL returns information about LU pools and the LUs that belong to them.

This verb can be used to obtain information about a specific LU or pool, or about multiple LUs or pools, depending on the options used.

## VCB structure

```
typedef struct query_lu_pool
{
    AP_UINT16      opcode;                /* verb operation code      */
    unsigned char  reserv2;              /* reserved                  */
    unsigned char  format;               /* reserved                  */
    AP_UINT16      primary_rc;           /* primary return code      */
    AP_UINT32      secondary_rc;         /* secondary return code    */
}
```



```

unsigned char    *buf_ptr;           /* pointer to buffer      */
AP_UINT32       buf_size;           /* buffer size            */
AP_UINT32       total_buf_size;     /* total buffer size required */
AP_UINT16       num_entries;        /* number of entries      */
AP_UINT16       total_num_entries;  /* total number of entries */
unsigned char    list_options;      /* listing options        */
unsigned char    reserv3;           /* reserved                */
unsigned char    pool_name[8];      /* Pool name              */
unsigned char    lu_name[8];        /* LU name                 */
} QUERY_LU_POOL;

```

```

typedef struct lu_pool_summary
{
    AP_UINT16     overlay_size;       /* size of returned entry */
    unsigned char pool_name[8];       /* Pool name               */
    unsigned char description[32];    /* resource description    */
    unsigned char reserv1[16];       /* reserved                 */
    AP_UINT16     num_active_lus;     /* number of active lus    */
    AP_UINT16     num_avail_lus;     /* number of available lus */
} LU_POOL_SUMMARY;

```

```

typedef struct lu_pool_detail
{
    AP_UINT16     overlay_size;       /* size of returned entry */
    unsigned char pool_name[8];       /* Pool name               */
    unsigned char description[32];    /* resource description    */
    unsigned char reserv1[16];       /* reserved                 */
    unsigned char lu_name[8];        /* LU name                  */
    unsigned char lu_sscp_sess_active; /* Is LU-SSCP session active */
    unsigned char appl_conn_active;  /* Is appl connection open */
    unsigned char plu_sess_active;   /* Is PLU-SLU session active */
} LU_POOL_DETAIL;

```

## Supplied parameters

The application supplies the following parameters:

### **opcode**

AP\_QUERY\_LU\_POOL

### **buf\_ptr**

A pointer to a data buffer that CS/AIX will use to return the requested information.

### **buf\_size**

Size of the supplied data buffer.

### **num\_entries**

Maximum number of entries for which data should be returned. If *list\_options* is set to AP\_SUMMARY, each entry is a single LU pool; if *list\_options* is set to AP\_DETAIL, each entry is an LU in a pool (or an entry indicating an empty LU pool).

To request a specific entry rather than a range, specify the value 1. To return as many entries as possible, specify zero; in this case, CS/AIX will return the maximum number of entries that can be accommodated in the supplied data buffer.

### **list\_options**

The position in the list from which CS/AIX should begin to return data, and the level of information required for each entry. Specify the level of information with one of the following values:

#### **AP\_SUMMARY**

Summary information only (list LU pools).

#### **AP\_DETAIL**

Detailed information (list individual LUs in LU pools).

Combine this value using a logical OR operation with one of the following values:

#### **AP\_FIRST\_IN\_LIST**

Start at the first entry in the list.

#### **AP\_LIST\_INCLUSIVE**

Start at the entry specified by the combination of the *pool\_name* and *lu\_name* parameters.

**AP\_LIST\_FROM\_NEXT**

Start at the entry immediately following the entry specified by the combination of the *pool\_name* and *lu\_name* parameters.

The list is ordered by *pool\_name* and then by *lu\_name*. For more information about how the list is ordered and how the application can obtain specific entries from it, see [“List options for QUERY\\_\\* Verbs” on page 33](#).

***pool\_name***

Name of LU pool. This value is ignored if *list\_options* is set to AP\_FIRST\_IN\_LIST. This is an 8-byte EBCDIC type-A string, padded on the right with spaces if the name is shorter than 8 characters.

***lu\_name***

LU name. This value is ignored if *list\_options* is set to AP\_FIRST\_IN\_LIST or AP\_SUMMARY. This is an 8-byte type-A EBCDIC string, padded on the right with spaces if the name is shorter than 8 characters.

To obtain information about all LUs in a pool, set *pool\_name* to the name of the pool, set *num\_entries* to 0, and set *lu\_name* to 8 binary zeros.

**Returned parameters: successful execution**

If the verb executes successfully, CS/AIX returns the following parameters:

***primary\_rc***

AP\_OK

***buf\_size***

Length of the information returned in the supplied buffer.

***total\_buf\_size***

Returned value indicating the size of buffer that would have been required to return all the list information requested. A value greater than *buf\_size* indicates that not all the available entries were returned.

***num\_entries***

Number of entries returned in the data buffer.

***total\_num\_entries***

Total number of entries available. A value greater than *num\_entries* indicates that not all the available entries were returned.

Each entry in the data buffer consists of the following parameters:

***lu\_pool\_summary.overlay\_size***

The size of the returned *lu\_pool\_summary* structure, and therefore the offset to the start of the next entry in the data buffer.

When your application needs to go through the returned buffer to find each *lu\_pool\_summary* structure in turn, it must use this value to move to the correct offset for the next data structure, and must not use the C `sizeof()` operator. This is because the size of the returned overlay may increase in future releases of CS/AIX; using the returned overlay size ensures that your application will continue to work with future releases.

***lu\_pool\_summary.pool\_name***

Name of LU pool. This is an 8-byte EBCDIC string, padded on the right with spaces if the name is shorter than 8 characters.

***lu\_pool\_summary.description***

A null-terminated text string describing the LU pool, as specified in the definition of the pool.

***lu\_pool\_summary.num\_active\_lus***

Number of LUs in the pool that are active.

***lu\_pool\_summary.num\_avail\_lus***

Number of LUs in the pool that are available for activation by a forced open request. It includes all LUs whose PU is active or whose host link can be auto-activated, and whose connection is free.

This count does not take account of the LU *model\_type*, *model\_name* and the DDDL support of the PU. If the open request specifies a particular value for *model\_type*, some LUs that are included in this count may not be available because they do not have the correct model type.

***lu\_pool\_detail.overlay\_size***

The size of the returned *lu\_pool\_detail* structure, and therefore the offset to the start of the next entry in the data buffer.

When your application needs to go through the returned buffer to find each *lu\_pool\_detail* structure in turn, it must use this value to move to the correct offset for the next data structure, and must not use the C `sizeof()` operator. This is because the size of the returned overlay may increase in future releases of CS/AIX; using the returned overlay size ensures that your application will continue to work with future releases.

***lu\_pool\_detail.pool\_name***

Name of LU pool to which the LU belongs. This is an 8-byte EBCDIC string, padded on the right with spaces if the name is shorter than 8 characters.

***lu\_pool\_detail.description***

A null-terminated text string describing the LU pool, as specified in the definition of the pool.

***lu\_pool\_detail.lu\_name***

LU name of the LU. This is an 8-byte type-A EBCDIC string, padded on the right with spaces if the name is shorter than 8 characters. If a single *lu\_pool\_detail* structure is returned for a particular pool name with a string of 8 binary zeros for the LU name, this indicates that the specified pool is empty.

***lu\_pool\_detail.lu\_sscp\_sess\_active***

Specifies whether the LU-SSCP session is active. Possible values are:

**AP\_YES**

The session is active.

**AP\_NO**

The session is inactive.

***lu\_pool\_detail.appl\_conn\_active***

Specifies whether an application is using the LU. Possible values are:

**AP\_YES**

An application is using the LU.

**AP\_NO**

No application is using the LU.

***lu\_pool\_detail.plu\_sess\_active***

Specifies whether the PLU-SLU session is active. Possible values are:

**AP\_YES**

The session is active.

**AP\_NO**

The session is inactive.

## Returned parameters: parameter check

If the verb does not execute because of a parameter error, CS/AIX returns the following parameters:

***primary\_rc***

AP\_PARAMETER\_CHECK

***secondary\_rc***

Possible values are:

**AP\_INVALID\_LU\_NAME**

The *list\_options* parameter was set to AP\_LIST\_INCLUSIVE to list all entries starting from the supplied name, but the *lu\_name* parameter was not valid.

## QUERY\_LU62\_TIMEOUT

### AP\_INVALID\_POOL\_NAME

The *list\_options* parameter was set to AP\_LIST\_INCLUSIVE to list all entries starting from the supplied name, but the *pool\_name* parameter was not valid.

### AP\_INVALID\_LIST\_OPTION

The *list\_options* parameter was not set to a valid value.

Appendix B, “Common return codes,” on page 661 lists further secondary return codes associated with AP\_PARAMETER\_CHECK, which are common to all NOF verbs.

## Returned parameters: other conditions

Appendix B, “Common return codes,” on page 661 lists further combinations of primary and secondary return codes that are common to all NOF verbs.

## QUERY\_LU62\_TIMEOUT

The QUERY\_LU62\_TIMEOUT verb returns information about the definition of an LU type 6.2 session timeout that was defined previously with a DEFINE\_LU62\_TIMEOUT verb.

The information is returned as a list. To obtain information about a specific timeout, or about several timeout values, specify values for the *resource\_type* and *resource\_name* parameters. If the *list\_options* parameter is set to AP\_FIRST\_IN\_LIST, the *resource\_type* and *resource\_name* parameters are ignored. The returned list is ordered on *resource\_type* and then on *resource\_name*.

For *resource\_type*, the ordering is:

1. Global timeouts
2. Local LU timeouts
3. Partner LU timeouts
4. Mode timeouts

For *resource\_name*, the ordering is by:

1. Name length
2. By ASCII lexicographical ordering for names of the same length

If the *list\_options* parameter is set to AP\_LIST\_FROM\_NEXT, the returned list starts for the next entry according to the defined ordering (whether or not the specified entry exists).

## VCB structure

```
typedef struct query_lu62_timeout
{
    AP_UINT16      opcode;                /* verb operation code      */
    unsigned char  reserv2;               /* reserved                  */
    unsigned char  format;               /* reserved                  */
    AP_UINT16      primary_rc;           /* primary return code      */
    AP_UINT32      secondary_rc;        /* secondary return code    */
    unsigned char  *buf_ptr;             /* buffer pointer           */
    AP_UINT32      buf_size;             /* buffer size              */
    AP_UINT32      total_buf_size;      /* total buffer size        */
    AP_UINT16      num_entries;          /* number of entries        */
    AP_UINT16      total_num_entries;   /* total number of entries  */
    unsigned char  list_options;        /* list options             */
    unsigned char  reserv3;             /* reserved                  */
    unsigned char  resource_type;       /* resource type            */
    unsigned char  resource_name[17];   /* resource name            */
} QUERY_LU62_TIMEOUT;
```

```
typedef struct lu62_timeout_data
{
    AP_UINT16      overlay_size;        /* overlay size             */
    unsigned char  resource_type;      /* resource type            */
    unsigned char  resource_name[17];  /* resource name            */
}
```

```

AP_UINT16      timeout;
} LU62_TIMEOUT_DATA;
/* timeout
*/

```

## Supplied parameters

The application supplies the following parameters:

### **opcode**

AP\_QUERY\_LU62\_TIMEOUT

### **buf\_ptr**

A pointer to a data buffer that CS/AIX will use to return the requested information.

### **buf\_size**

Size of the supplied data buffer.

### **num\_entries**

Maximum number of entries for which data should be returned. To request data for a specific entry rather than a range, specify the value 1. To return as many entries as possible, specify 0; in this case, CS/AIX will return the maximum number of entries that can be accommodated in the supplied data buffer.

### **list\_options**

The position in the list of entries from which CS/AIX begins to return data. The list is ordered by *resource\_type* in the order AP\_GLOBAL\_TIMEOUT, AP\_LOCAL\_LU\_TIMEOUT, AP\_PARTNER\_LU\_TIMEOUT, AP\_MODE\_TIMEOUT, then by *resource\_name* in order of the name length, then by ASCII lexicographical ordering for names of the same length.

Possible values are:

#### **AP\_FIRST\_IN\_LIST**

Start at the first entry in the list

#### **AP\_LIST\_INCLUSIVE**

Start at the entry specified by the combination of the *resource\_type* and *resource\_name* parameters

#### **AP\_LIST\_FROM\_NEXT**

Start at the entry immediately following the entry specified by the combination of the *resource\_type* and *resource\_name* parameters

For more information about how the list is ordered and how the application can obtain specific entries from it, see [“List options for QUERY\\_\\* Verbs” on page 33](#).

### **resource\_type**

Specifies the type of timeout being queried. This parameter is ignored if *list\_options* is set to AP\_FIRST\_IN\_LIST.

Possible values are:

#### **AP\_GLOBAL\_TIMEOUT**

Timeout applies to all LU 6.2 sessions for the local node.

#### **AP\_LOCAL\_LU\_TIMEOUT**

Timeout applies to all LU 6.2 sessions for the local LU specified in the *resource\_name* parameter.

#### **AP\_PARTNER\_LU\_TIMEOUT**

Timeout applies to all LU 6.2 sessions to the partner LU specified in the *resource\_name* parameter.

#### **AP\_MODE\_TIMEOUT**

Timeout applies to all LU 6.2 sessions using the mode specified in the *resource\_name* parameter.

### **resource\_name**

Name of the resource being queried. This value can be one of the following:

- If *resource\_type* is set to AP\_GLOBAL\_TIMEOUT, do not specify this parameter.
- If *resource\_type* is set to AP\_LOCAL\_LU\_TIMEOUT, only the first 8 bytes of *resource\_name* are valid and should be set to the name of the local LU. This is an 8-byte alphanumeric type-A EBCDIC string

## QUERY\_LU62\_TIMEOUT

starting with a letter, padded to the right with EBCDIC spaces. Set the remaining nine bytes to all zeros.

- If *resource\_type* is set to AP\_PARTNER\_LU\_TIMEOUT, all 17 bytes of *resource\_name* are valid and should be set to the fully-qualified name of the partner LU which is padded on the right with EBCDIC spaces. The name consists of a 1-8 type-A character network name, followed by an EBCDIC dot (period) character, followed by a 1-8 type-A character partner LU name.
- If *resource\_type* is set to AP\_MODE\_TIMEOUT, only the first 8 bytes of *resource\_name* are valid and should be set to the name of the mode. This is an 8-byte alphanumeric type-A EBCDIC string starting with a letter, padded to the right with EBCDIC spaces. Set the remaining 9 bytes to all zeros.

This parameter is ignored if *list\_options* is set to AP\_FIRST\_IN\_LIST.

### Returned parameters: successful execution

If the verb executes successfully, CS/AIX returns the following parameters:

#### ***primary\_rc***

AP\_OK

#### ***buf\_size***

Length of the information returned in the supplied buffer.

#### ***total\_buf\_size***

Returned value indicating the size of buffer that would have been required to return all the list information requested. A value greater than *buf\_size* indicates that not all the available entries were returned.

#### ***num\_entries***

Number of entries returned in the data buffer.

#### ***total\_num\_entries***

Total number of entries available. A value greater than *num\_entries* indicates that not all the available entries were returned.

Each entry in the data buffer consists of the following parameters:

#### ***resource\_type***

The type of the timeout. Possible values are:

##### **AP\_GLOBAL\_TIMEOUT**

Timeout applies to all LU 6.2 sessions for the local node. The *resource\_name* parameter is set to all zeros.

##### **AP\_LOCAL\_LU\_TIMEOUT**

Timeout applies to all LU 6.2 sessions for the local LU indicated by the *resource\_name* parameter.

##### **AP\_PARTNER\_LU\_TIMEOUT**

Timeout applies to all LU 6.2 sessions to the partner LU indicated by the *resource\_name* parameter.

##### **AP\_MODE\_TIMEOUT**

Timeout applies to all LU 6.2 sessions using the mode indicated by the *resource\_name* parameter.

#### ***resource\_name***

Name of the resource. This name is a local LU, a partner LU, or a mode, depending on the value of the *resource\_type* parameter. This parameter is set to zeros if *resource\_type* is set to AP\_GLOBAL\_TIMEOUT.

#### ***timeout***

Timeout period in seconds. A value of 0 (zero) indicates that the session times out immediately after it becomes free.

### Returned parameters: parameter check

If the verb does not execute because of a parameter error, CS/AIX returns the following parameters:

**primary\_rc**

AP\_PARAMETER\_CHECK

**secondary\_rc**

Possible values are:

**AP\_INVALID\_RESOURCE\_NAME**

The *list\_options* parameter was set to AP\_LIST\_INCLUSIVE to list all entries starting from the supplied name and type, but the combination of *resource\_type* and *resource\_name* did not match any that are configured.

**AP\_INVALID\_LIST\_OPTION**

The *list\_options* parameter was not set to a valid value.

Appendix B, “Common return codes,” on page 661 lists further secondary return codes associated with AP\_PARAMETER\_CHECK, which are common to all NOF verbs.

## Returned parameters: other conditions

Appendix B, “Common return codes,” on page 661 lists further combinations of primary and secondary return codes that are common to all NOF verbs.

## QUERY\_MDS\_APPLICATION

QUERY\_MDS\_APPLICATION returns a list of applications that have registered for MDS-level messages by issuing the MS verb REGISTER\_MS\_APPLICATION. For more information about this verb, see the *IBM Communications Server for Data Center Deployment on AIX or Linux MS Programmer's Guide*.

This verb can be used to obtain information about a specific application or about multiple applications, depending on the options used.

This verb must be issued to a running node.

## VCB structure

```
typedef struct query_mds_application
{
    AP_UINT16      opcode;                /* verb operation code          */
    unsigned char  reserv2;              /* reserved                      */
    unsigned char  format;               /* reserved                      */
    AP_UINT16      primary_rc;           /* primary return code          */
    AP_UINT32      secondary_rc;         /* secondary return code        */
    unsigned char  *buf_ptr;             /* pointer to buffer            */
    AP_UINT32      buf_size;             /* buffer size                  */
    AP_UINT32      total_buf_size;       /* total buffer size required   */
    AP_UINT16      num_entries;          /* number of entries            */
    AP_UINT16      total_num_entries;    /* total number of entries      */
    unsigned char  list_options;         /* listing options              */
    unsigned char  reserv3;              /* reserved                      */
    unsigned char  application[8];       /* application                   */
} QUERY_MDS_APPLICATION;
```

```
typedef struct mds_application_data
{
    AP_UINT16      overlay_size;         /* size of returned entry       */
    unsigned char  application[8];       /* application name              */
    AP_UINT16      max_rcv_size;        /* max data size appl can receive */
    unsigned char  reserva[20];         /* reserved                      */
} MDS_APPLICATION_DATA;
```

## Supplied parameters

The application supplies the following parameters:

**opcode**

AP\_QUERY\_MDS\_APPLICATION

**buf\_ptr**

A pointer to a data buffer that CS/AIX will use to return the requested information.

**buf\_size**

Size of the supplied data buffer.

**num\_entries**

Maximum number of applications for which data should be returned. To request data for a specific application rather than a range, specify the value 1. To return as many entries as possible, specify zero; in this case, CS/AIX will return the maximum number of entries that can be accommodated in the supplied data buffer.

**list\_options**

The position in the list of applications from which CS/AIX should begin to return data. Possible values are:

**AP\_FIRST\_IN\_LIST**

Start at the first entry in the list.

**AP\_LIST\_INCLUSIVE**

Start at the entry specified by the application parameter.

**AP\_LIST\_FROM\_NEXT**

Start at the entry immediately following the entry specified by the application parameter.

For more information about how the list is ordered and how the application can obtain specific entries from it, see [“List options for QUERY\\_\\* Verbs”](#) on page 33.

**application**

Application name for which information is required, or the name to be used as an index into the list. This parameter is ignored if *list\_options* is set to AP\_FIRST\_IN\_LIST. This is an 8-byte type-A EBCDIC string, padded on the right with spaces if the name is shorter than 8 characters.

## Returned parameters: successful execution

If the verb executes successfully, CS/AIX returns the following parameters:

**primary\_rc**

AP\_OK

**buf\_size**

Length of the information returned in the supplied buffer.

**total\_buf\_size**

Returned value indicating the size of buffer that would have been required to return all the list information requested. A value greater than *buf\_size* indicates that not all the available entries were returned.

**num\_entries**

Number of entries returned in the data buffer.

**total\_num\_entries**

Total number of entries available. A value greater than *num\_entries* indicates that not all the available entries were returned.

Each entry in the data buffer consists of the following parameters:

**mds\_application\_data.overlay\_size**

The size of the returned *mds\_application\_data* structure, and therefore the offset to the start of the next entry in the data buffer.

When your application needs to go through the returned buffer to find each *mds\_application\_data* structure in turn, it must use this value to move to the correct offset for the next data structure, and must not use the C `sizeof()` operator. This is because the size of the returned overlay may increase in future releases of CS/AIX; using the returned overlay size ensures that your application will continue to work with future releases.



***mds\_application\_data.application***

Name of registered application. This is an 8-byte type-A EBCDIC string, padded on the right with spaces if the name is shorter than 8 characters.

***mds\_application\_data.max\_rcv\_size***

The maximum number of bytes that the application can receive in one message (this is specified when an application registers with MDS). For more information about MDS-level application registration, refer to the *IBM Communications Server for Data Center Deployment on AIX or Linux MS Programmer's Guide*.

**Returned parameters: parameter check**

If the verb does not execute because of a parameter error, CS/AIX returns the following parameters:

***primary\_rc***

AP\_PARAMETER\_CHECK

***secondary\_rc***

Possible values are:

**AP\_INVALID\_APPLICATION\_NAME**

The *list\_options* parameter was set to AP\_LIST\_INCLUSIVE to list all entries starting from the supplied name, but the *application* parameter was not valid.

**AP\_INVALID\_LIST\_OPTION**

The *list\_options* parameter was not set to a valid value.

Appendix B, “Common return codes,” on page 661 lists further secondary return codes associated with AP\_PARAMETER\_CHECK, which are common to all NOF verbs.

**Returned parameters: function not supported**

If the verb does not execute successfully because the local node configuration does not support it, CS/AIX returns the following parameters:

***primary\_rc*****AP\_FUNCTION\_NOT\_SUPPORTED**

The local node does not support MS network management functions; this is defined by the *mds\_supported* parameter on the DEFINE\_NODE verb.

**Returned parameters: other conditions**

Appendix B, “Common return codes,” on page 661 lists further combinations of primary and secondary return codes that are common to all NOF verbs.

**QUERY\_MDS\_STATISTICS**

QUERY\_MDS\_STATISTICS returns Management Services statistics. This verb can be used to gauge the level of MDS routing traffic. The information can also be used to determine the required size of the send alert queue, which is configured using the DEFINE\_NODE verb.

This verb must be issued to a running node.

**VCB structure**

```
typedef struct query_mds_statistics
{
    AP_UINT16      opcode;                /* verb operation code      */
    unsigned char  reserv2;              /* reserved                  */
    unsigned char  format;               /* reserved                  */
    AP_UINT16      primary_rc;           /* primary return code      */
    AP_UINT32      secondary_rc;         /* secondary return code    */
    AP_UINT32      alerts_sent;          /* number of alert sends    */
    AP_UINT32      alert_errors_rcvd;    /* error messages received  */
}
```

## QUERY\_MDS\_STATISTICS

```
AP_UINT32      uncorrelated_alert_errors; /* for alert sends */
AP_UINT32      mds_mus_rcvd_local;        /* uncorrelated alert errors */
AP_UINT32      mds_mus_rcvd_remote;       /* received */
AP_UINT32      mds_mus_delivered_local;   /* number of MDS_MUs received */
AP_UINT32      mds_mus_delivered_remote; /* from local applications */
AP_UINT32      parse_errors;              /* number of MDS_MUs received */
AP_UINT32      failed_deliveries;         /* from remote applications */
AP_UINT32      ds_searches_performed;     /* number of MDS_MUs delivered */
AP_UINT32      unverified_errors;         /* to local applications */
AP_UINT32      unsigned char reserva[20]; /* number of MDS_MUs delivered */
} QUERY_MDS_STATISTICS;                  /* to remote applications */
                                        /* number of MDS_MUs received */
                                        /* with parse errors */
                                        /* number of MDS_MUs where */
                                        /* delivery failed */
                                        /* number of DS searches */
                                        /* performed */
                                        /* number of unverified errors */
                                        /* reserved */
```

## Supplied parameters

The application supplies the following parameter:

### **opcode**

AP\_QUERY\_MDS\_STATISTICS

## Returned parameters: successful execution

If the verb executes successfully, CS/AIX returns the following parameters:

### **primary\_rc**

AP\_OK

### **alerts\_sent**

Number of locally originated alerts sent using the MDS transport system.

### **alert\_errors\_rcvd**

Number of error messages received by MDS indicating a delivery failure for a message containing an alert.

### **uncorrelated\_errors\_rcvd**

Number of error messages received by MDS indicating a delivery failure for a message containing an alert. Delivery failure occurs when the error message could not be correlated to an alert on the MDS send alert queue. MDS maintains a fixed-size queue where it caches alerts sent to the problem determination focal point. Once the queue reaches maximum size, the oldest alert will be discarded and replaced by the new alert. If a delivery error message is received, MDS attempts to correlate the error message to a cached alert so that the alert may be held until the problem determination focal point is restored.

**Note:** The two counts *alert\_errors\_rcvd* and *uncorrelated\_errors\_rcvd* can be used to check that the size of the send alert queue (specified on `DEFINE_NODE`) is appropriate. If the value of *uncorrelated\_errors\_rcvd* increases over time, this indicates that the send alert queue size is too small.

### **mds\_mus\_rcvd\_local**

Number of MDS\_MUs received from local applications.

### **mds\_mus\_rcvd\_remote**

Number of MDS\_MUs received from remote nodes using the `MDS_RECEIVE` and `MSU_HANDLER` transaction programs.

### **mds\_mus\_delivered\_local**

Number of MDS\_MUs successfully delivered to local applications.

### **mds\_mus\_delivered\_remote**

Number of MDS\_MUs successfully delivered to a remote node using the `MDS_SEND` transaction program.

**parse\_errors**

Number of MDS\_MUs received which contained header format errors.

**failed\_deliveries**

Number of MDS\_MUs this node failed to deliver.

**ds\_searches\_performed**

Number of Directory Services searches used to locate the next hop for an MDS\_MU. (Significant for network nodes only).

**unverified\_errors**

Number of routing errors due to using unverified (local Directory Services search) data for determining the next hop for an MDS\_MU. Each time one of these errors occurs, Directory Services must repeat the search using either a Central Directory Search or a broadcast search mechanism. (Significant for network nodes only).

**Returned parameters: function not supported**

If the verb does not execute successfully because the local node configuration does not support it, CS/AIX returns the following parameters:

**primary\_rc****AP\_FUNCTION\_NOT\_SUPPORTED**

The local node does not support MS network management functions; this is defined by the *mds\_supported* parameter on the DEFINE\_NODE verb.

**Returned parameters: other conditions**

Appendix B, “Common return codes,” on page 661 lists further combinations of primary and secondary return codes that are common to all NOF verbs.

**QUERY\_MODE**

QUERY\_MODE returns information about modes that a local LU is using, or has used, with partner LUs.

This verb can be used to obtain information about a specific partner LU-mode combination or about multiple modes, and about modes for which sessions are currently active or about all modes that have been used, depending on the options used. This verb returns information about current usage of the modes and LUs, not about their definition; use QUERY\_MODE\_DEFINITION to obtain the definition of the modes and LUs.

This verb must be issued to a running node.

**VCB structure**

```
typedef struct query_mode
{
    AP_UINT16      opcode;                /* verb operation code          */
    unsigned char  reserv2;               /* reserved                      */
    unsigned char  format;                /* reserved                      */
    AP_UINT16      primary_rc;            /* primary return code          */
    AP_UINT32      secondary_rc;          /* secondary return code        */
    unsigned char  *buf_ptr;              /* pointer to buffer            */
    AP_UINT32      buf_size;              /* buffer size                  */
    AP_UINT32      total_buf_size;        /* total buffer size required    */
    AP_UINT16      num_entries;           /* number of entries            */
    AP_UINT16      total_num_entries;     /* total number of entries      */
    unsigned char  list_options;          /* listing options              */
    unsigned char  reserv3;               /* reserved                      */
    unsigned char  lu_name[8];            /* LU name                      */
    unsigned char  lu_alias[8];           /* LU alias                     */
    unsigned char  plu_alias[8];          /* partner LU alias             */
    unsigned char  fqplu_name[17];        /* fully qualified partner LU name */
    unsigned char  mode_name[8];          /* mode name                    */
    unsigned char  active_sessions;       /* active sessions only filter  */
} QUERY_MODE;
```

## QUERY\_MODE

```
typedef struct mode_summary
{
    AP_UINT16      overlay_size;          /* size of returned entry      */
    unsigned char  mode_name[8];         /* mode name                   */
    unsigned char  description[32];     /* resource description        */
    unsigned char  reserv2[16];        /* reserved                    */
    AP_UINT16      sess_limit;          /* current session limit       */
    AP_UINT16      act_sess_count;     /* currently active sessions count */
    unsigned char  fqplu_name[17];     /* fully-qualified partner LU name */
    unsigned char  reserv1[3];        /* reserved                    */
} MODE_SUMMARY;
```

```
typedef struct mode_detail
{
    AP_UINT16      overlay_size;          /* size of returned entry      */
    unsigned char  mode_name[8];         /* mode name                   */
    unsigned char  description[32];     /* resource description        */
    unsigned char  reserv2[16];        /* reserved                    */
    AP_UINT16      sess_limit;          /* session limit              */
    AP_UINT16      act_sess_count;     /* currently active sessions count */
    unsigned char  fqplu_name[17];     /* fully-qualified partner LU name */
    unsigned char  reserv1[3];        /* reserved                    */
    AP_UINT16      min_conwinners_source; /* minimum conwinner sess limit */
    AP_UINT16      min_conwinners_target; /* minimum conloser sess limit */
    unsigned char  drain_source;       /* drain source?              */
    unsigned char  drain_partner;     /* drain partner?             */
    AP_UINT16      auto_act;           /* auto activated conwinner   */
    /* session limit */
    AP_UINT16      act_cw_count;       /* active conwinner sessions count */
    AP_UINT16      act_cl_count;       /* active conloser sessions count */
    unsigned char  sync_level;        /* synchronization level      */
    unsigned char  default_ru_size;    /* default RU size to maximize */
    /* performance */
    AP_UINT16      max_neg_sess_limit; /* maximum negotiated session limit */
    AP_UINT16      max_rcv_ru_size;   /* maximum receive RU size   */
    AP_UINT16      pending_session_count; /* pending sess count for mode */
    AP_UINT16      termination_count; /* termination count for mode */
    AP_UINT16      implicit;          /* implicit or explicit entry */
    unsigned char  reserva[15];       /* reserved                    */
} MODE_DETAIL;
```

## Supplied parameters

The application supplies the following parameters:

### ***opcode***

AP\_QUERY\_MODE

### ***buf\_ptr***

A pointer to a data buffer that CS/AIX will use to return the requested information.

### ***buf\_size***

Size of the supplied data buffer.

### ***num\_entries***

Maximum number of modes for which data should be returned. To request data for a specific mode rather than a range, specify the value 1. To return as many entries as possible, specify zero; in this case, CS/AIX will return the maximum number of entries that can be accommodated in the supplied data buffer.

### ***list\_options***

The position in the list from which CS/AIX should begin to return data, and the level of information required for each entry. Specify the level of information with one of the following values:

#### **AP\_SUMMARY**

Summary information only.

#### **AP\_DETAIL**

Detailed information.

Combine this value using a logical OR operation with one of the following values:

**AP\_FIRST\_IN\_LIST**

Start at the first entry in the list (the first partner LU and mode for the specified local LU).

**AP\_LIST\_INCLUSIVE**

Start at the entry specified by the supplied partner LU name and mode name.

**AP\_LIST\_FROM\_NEXT**

Start at the entry immediately following the entry specified by the supplied partner LU name and mode name.

For AP\_FIRST\_IN\_LIST, the entry used as the index into the list is defined by the combination of *lu\_name* (or *lu\_alias*) and *fqplu\_name* (or *plu\_alias*). If *fqplu\_name* or *plu\_alias* is not specified, the entry used as the index is *lu\_name* (or *lu\_alias*).

For AP\_LIST\_INCLUSIVE or AP\_LIST\_FROM\_NEXT, the entry used as the index into the list is defined by the combination of *lu\_name* (or *lu\_alias*), *fqplu\_name* (or *plu\_alias*) and *mode\_name* specified. For more information about how the list is ordered and how the application can obtain specific entries from it, see [“List options for QUERY\\_\\* Verbs” on page 33](#).

***lu\_name***

LU name. This is an 8-byte type-A EBCDIC string, padded on the right with spaces if the name is shorter than 8 characters. To specify that the LU is identified by its alias rather than its LU name, set this parameter to 8 binary zeros and specify the LU alias in the following parameter.

***lu\_alias***

Locally defined LU alias. This parameter is used only if *lu\_name* is set to 8 binary zeros; it is ignored otherwise.

The alias is an 8-byte ASCII string, padded on the right with spaces if the name is shorter than 8 bytes. To indicate the LU associated with the CP (the default LU), set both *lu\_name* and *lu\_alias* to binary zeros.

***plu\_alias***

Partner LU alias. This is an 8-byte ASCII string, padded on the right with spaces if the name is shorter than 8 bytes. If *list\_options* is set to AP\_FIRST\_IN\_LIST, this parameter is ignored; otherwise you must specify either the LU alias or the fully qualified LU name for the partner LU. To specify that the LU is identified by its LU name rather than its alias, set this parameter to 8 binary zeros and specify the LU name in the following parameter.

***fqplu\_name***

Fully qualified network name for the partner LU. If *list\_options* is set to AP\_FIRST\_IN\_LIST, this parameter is ignored; otherwise you must specify either the LU alias or the fully qualified LU name for the partner LU. This parameter is used only if *plu\_alias* is set to 8 binary zeros; it is ignored otherwise.

The name is a 17-byte EBCDIC string, right-padded with EBCDIC spaces. It consists of a network ID of up to 8 A-string characters, an EBCDIC dot (period) character, and a network name of up to 8 A-string characters.

***mode\_name***

Mode name which designates the network properties for a group of sessions. This is an 8-byte type-A EBCDIC string, padded on the right with spaces if the name is shorter than 8 characters. This parameter is ignored if *list\_options* is set to AP\_FIRST\_IN\_LIST.

***active\_sessions***

Specifies whether to return information only on modes for which sessions are active, or on all modes. Possible values are:

**AP\_YES**

Return information only on modes for which sessions are currently active.

**AP\_NO**

Return information about all modes for which sessions are active or have been active.

**Returned parameters: successful execution**

If the verb executes successfully, CS/AIX returns the following parameters:

***primary\_rc***

AP\_OK

***buf\_size***

Length of the information returned in the supplied buffer.

***total\_buf\_size***

Returned value indicating the size of buffer that would have been required to return all the list information requested. A value greater than *buf\_size* indicates that not all the available entries were returned.

***num\_entries***

Number of entries returned in the data buffer.

***total\_num\_entries***

Total number of entries available. A value greater than *num\_entries* indicates that not all the available entries were returned.

Each entry in the data buffer consists of the following parameters:

***mode\_summary.overlay\_size***

The size of the returned *mode\_summary* structure, and therefore the offset to the start of the next entry in the data buffer.

When your application needs to go through the returned buffer to find each *mode\_summary* structure in turn, it must use this value to move to the correct offset for the next data structure, and must not use the C `sizeof()` operator. This is because the size of the returned overlay may increase in future releases of CS/AIX; using the returned overlay size ensures that your application will continue to work with future releases.

***mode\_summary.mode\_name***

Mode name. This is an 8-byte type-A EBCDIC string, padded on the right with spaces if the name is shorter than 8 characters.

***mode\_summary.description***

A null-terminated text string describing the mode, as specified in the definition of the mode.

***mode\_summary.sess\_limit***

Current session limit.

***mode\_summary.act\_sess\_count***

Total number of active sessions between the specified local LU and partner LU using the mode.

***mode\_summary.fqplu\_name***

Fully qualified name of the partner LU. The name is a 17-byte EBCDIC string, right-padded with EBCDIC spaces. It consists of a network ID of up to 8 A-string characters, an EBCDIC dot (period) character, and a network name of up to 8 A-string characters.

***mode\_detail.overlay\_size***

The size of the returned *mode\_detail* structure, and therefore the offset to the start of the next entry in the data buffer.

When your application needs to go through the returned buffer to find each *mode\_detail* structure in turn, it must use this value to move to the correct offset for the next data structure, and must not use the C `sizeof()` operator. This is because the size of the returned overlay may increase in future releases of CS/AIX; using the returned overlay size ensures that your application will continue to work with future releases.

***mode\_detail.mode\_name***

Mode name. This is an 8-byte type-A EBCDIC string, padded on the right with spaces if the name is shorter than 8 characters.

***mode\_detail.description***

A null-terminated text string describing the mode, as specified in the definition of the mode.

***mode\_detail.sess\_limit***

Current session limit.

***mode\_detail.act\_sess\_count***

Total number of active sessions between the specified local LU and partner LU using the mode.

***mode\_detail.fqplu\_name***

Fully qualified name of the partner LU. The name is a 17-byte EBCDIC string, right-padded with EBCDIC spaces. It consists of a network ID of up to 8 A-string characters, an EBCDIC dot (period) character, and a network name of up to 8 A-string characters.

***mode\_detail.min\_conwinners\_source***

Specifies the minimum number of sessions on which the local LU is the contention winner.

***mode\_detail.min\_conwinners\_target***

Specifies the minimum number of sessions on which the local LU is the contention loser.

***mode\_detail.drain\_source***

Specifies whether the local LU satisfies waiting session requests before deactivating a session when session limits are changed or reset. Possible values are:

**AP\_YES**

Waiting session requests will be satisfied before sessions are deactivated.

**AP\_NO**

Waiting session requests will not be satisfied.

***mode\_detail.drain\_partner***

Specifies whether the partner LU satisfies waiting session requests before deactivating a session when session limits are changed or reset. Possible values are:

**AP\_YES**

Waiting session requests will be satisfied before sessions are deactivated.

**AP\_NO**

Waiting session requests will not be satisfied.

***mode\_detail.auto\_act***

Number of contention winner sessions that are automatically activated following the CNOS exchange with the partner LU.

***mode\_detail.act\_cw\_count***

Number of active contention winner sessions using this mode. (The local LU does not need to "bid" before using one of these sessions.)

***mode\_detail.act\_cl\_count***

Number of active, contention loser sessions using this mode. (The local LU must "bid" before using one of these sessions.)

***mode\_detail.sync\_level***

Specifies the synchronization level supported by the mode. Possible values are:

**AP\_CONFIRM**

The mode supports synchronization using the CONFIRM and CONFIRMED verbs.

**AP\_SYNCPT**

The mode supports Syncpoint functions.

**AP\_NONE**

The mode does not support synchronization.

***mode\_detail.default\_ru\_size***

Specifies whether the default upper bound for the maximum RU size will be used. Possible values are:

**AP\_YES**

CS/AIX ignores the maximum RU size specified in the definition of the mode, and sets the upper bound for the maximum RU size to the largest value that can be accommodated in the link BTU size.

**AP\_NO**

CS/AIX uses the maximum RU size specified in the definition of the mode.

## QUERY\_MODE

### ***mode\_detail.max\_neg\_sess\_limit***

Maximum negotiable session limit. Specifies the maximum session limit that a local LU can use with this mode name during its CNOS processing as the target LU.

### ***mode\_detail.max\_rcv\_ru\_size***

Maximum received RU size.

### ***mode\_detail.pending\_session\_count***

Specifies the number of sessions pending (waiting for session activation to complete).

### ***mode\_detail.termination\_count***

If a previous CNOS verb has set the mode session limit to zero, but sessions are still active because conversations were using them or waiting to use them, this parameter specifies the number of sessions that have not yet been deactivated.

### ***mode\_detail.implicit***

Specifies whether the entry was created by an implicit or explicit definition. Possible values are:

#### **AP\_YES**

The entry is an implicit entry.

#### **AP\_NO**

The entry is an explicit entry.

## Returned parameters: parameter check

If the verb does not execute because of a parameter error, CS/AIX returns the following parameters:

### ***primary\_rc***

AP\_PARAMETER\_CHECK

### ***secondary\_rc***

Possible values are:

#### **AP\_INVALID\_LIST\_OPTION**

The *list\_options* parameter was not set to a valid value.

#### **AP\_INVALID\_LU\_ALIAS**

The *list\_options* parameter was set to AP\_LIST\_INCLUSIVE to list all entries starting from the supplied name, but the *lu\_alias* parameter was not valid.

#### **AP\_INVALID\_LU\_NAME**

The *list\_options* parameter was set to AP\_LIST\_INCLUSIVE to list all entries starting from the supplied name, but the *lu\_name* parameter was not valid.

#### **AP\_INVALID\_MODE\_NAME**

The *list\_options* parameter was set to AP\_LIST\_INCLUSIVE to list all entries starting from the supplied name, but the *mode\_name* parameter was not valid.

#### **AP\_INVALID\_PLU\_NAME**

The *list\_options* parameter was set to AP\_LIST\_INCLUSIVE to list all entries starting from the supplied name, but one of the following conditions applies:

- The *fqplu\_name* parameter does not match the name of any of this local LU's partners.
- No sessions have been active (since the node was last started) for the specified combination of local LU, partner LU, and mode.

Appendix B, “[Common return codes](#),” on page 661 lists further secondary return codes associated with AP\_PARAMETER\_CHECK, which are common to all NOF verbs.

## Returned parameters: other conditions

Appendix B, “[Common return codes](#),” on page 661 lists further combinations of primary and secondary return codes that are common to all NOF verbs.



## QUERY\_MODE\_DEFINITION

QUERY\_MODE\_DEFINITION returns information about modes defined using DEFINE\_MODE, or about SNA-defined modes.

This verb can be used to obtain either summary or detailed information, about a specific mode or about multiple modes, depending on the options used. It returns information about the definition of the modes, not about their current usage; use QUERY\_MODE to obtain information about the current usage of a mode by local and partner LUs.

This verb cannot be used to return information about the default COS name that will be used for any unrecognized mode names; use QUERY\_MODE\_TO\_COS\_MAPPING to do this.

### VCB structure

```
typedef struct query_mode_definition
{
    AP_UINT16      opcode;                /* verb operation code      */
    unsigned char  reserv2;               /* reserved                  */
    unsigned char  format;               /* reserved                  */
    AP_UINT16      primary_rc;           /* primary return code      */
    AP_UINT32      secondary_rc;         /* secondary return code    */
    unsigned char  *buf_ptr;             /* pointer to buffer        */
    AP_UINT32      buf_size;             /* buffer size              */
    AP_UINT32      total_buf_size;       /* total buffer size required */
    AP_UINT16      num_entries;          /* number of entries        */
    AP_UINT16      total_num_entries;    /* total number of entries  */
    unsigned char  list_options;         /* listing options          */
    unsigned char  reserv3;             /* reserved                  */
    unsigned char  mode_name[8];        /* mode name                 */
} QUERY_MODE_DEFINITION;
```

```
typedef struct mode_def_summary
{
    AP_UINT16      overlay_size;          /* size of returned entry   */
    unsigned char  mode_name[8];         /* mode name                 */
    unsigned char  description[32];      /* resource description      */
    unsigned char  reserv1[16];         /* reserved                  */
} MODE_DEF_SUMMARY;
```

```
typedef struct mode_def_detail
{
    AP_UINT16      overlay_size;          /* size of returned entry   */
    unsigned char  mode_name[8];         /* mode name                 */
    MODE_CHARS     mode_chars;           /* mode characteristics     */
} MODE_DEF_DETAIL;
```

```
typedef struct mode_chars
{
    unsigned char  description[32];      /* resource description      */
    unsigned char  reserv2[16];         /* reserved                  */
    AP_UINT16      max_ru_size_upper;   /* maximum RU size upper bound */
    unsigned char  receive_pacing_win; /* receive pacing window    */
    unsigned char  default_ru_size;     /* default RU size to       */
    AP_UINT16      max_neg_sess_lim;    /* maximize performance     */
    AP_UINT16      max_neg_sess_lim;    /* maximum negotiable session */
    AP_UINT16      max_neg_sess_lim;    /* limit                    */
    AP_UINT16      plu_mode_session_limit; /* LU-mode session limit   */
    AP_UINT16      min_conwin_src;      /* minimum source contention */
    AP_UINT16      min_conwin_src;      /* winner sessions         */
    unsigned char  cos_name[8];         /* class of service name    */
    unsigned char  cryptography;        /* cryptography (reserved)  */
    unsigned char  compression;         /* data compression supported? */
    AP_UINT16      auto_act;            /* number of sessions to be */
    AP_UINT16      auto_act;            /* activated automatically  */
    AP_UINT16      min_conloser_src;    /* minimum source contention */
    AP_UINT16      min_conloser_src;    /* loser                    */
    AP_UINT16      max_ru_size_low;     /* maximum RU size lower bound */
    AP_UINT16      max_receive_pacing_win; /* maximum receive pacing   */
    AP_UINT16      max_receive_pacing_win; /* window                   */
    unsigned char  max_compress_lvl;    /* max level of data compression */
    unsigned char  max_decompress_lvl; /* max level of data decompression */
    unsigned char  comp_in_series;      /* reserved                  */
}
```

## QUERY\_MODE\_DEFINITION

```
    unsigned char    reserv4[25];           /* reserved          */
} MODE_CHARS;
```

### Supplied parameters

The application supplies the following parameters:

#### ***opcode***

AP\_QUERY\_MODE\_DEFINITION

#### ***buf\_ptr***

A pointer to a data buffer that CS/AIX will use to return the requested information.

#### ***buf\_size***

Size of the supplied data buffer.

#### ***num\_entries***

Maximum number of modes for which data should be returned. To request data for a specific mode rather than a range, specify the value 1. To return as many entries as possible, specify zero; in this case, CS/AIX will return the maximum number of entries that can be accommodated in the supplied data buffer.

#### ***list\_options***

The position in the list from which CS/AIX should begin to return data, and the level of information required for each entry. Specify the level of information with one of the following values:

##### **AP\_SUMMARY**

Summary information only.

##### **AP\_DETAIL**

Detailed information.

Combine this value using a logical OR operation with one of the following values:

##### **AP\_FIRST\_IN\_LIST**

Start at the first entry in the list.

##### **AP\_LIST\_INCLUSIVE**

Start at the entry specified by the *mode\_name* parameter.

##### **AP\_LIST\_FROM\_NEXT**

Start at the entry immediately following the entry specified by the *mode\_name* parameter.

For more information about how the application can obtain specific entries from the list, see [“List options for QUERY\\_\\* Verbs” on page 33](#). This verb differs from other QUERY\_\* verbs in that the modes are listed in the order they are created.

#### ***mode\_name***

Mode name which designates the network properties for a group of sessions. This parameter is ignored if *list\_options* is set to AP\_FIRST\_IN\_LIST. This is an 8-byte type-A EBCDIC string, padded on the right with spaces if the name is shorter than 8 characters.

### Returned parameters: successful execution

If the verb executes successfully, CS/AIX returns the following parameters:

#### ***primary\_rc***

AP\_OK

#### ***buf\_size***

Length of the information returned in the supplied buffer.

#### ***total\_buf\_size***

Returned value indicating the size of buffer that would have been required to return all the list information requested. A value greater than *buf\_size* indicates that not all the available entries were returned.

**num\_entries**

Number of entries returned in the data buffer.

**total\_num\_entries**

Total number of entries available. A value greater than *num\_entries* indicates that not all the available entries were returned.

Each entry in the data buffer consists of the following parameters:

**mode\_def\_summary.overlay\_size**

The size of the returned *mode\_def\_summary* structure, and therefore the offset to the start of the next entry in the data buffer.

When your application needs to go through the returned buffer to find each *mode\_def\_summary* structure in turn, it must use this value to move to the correct offset for the next data structure, and must not use the C `sizeof()` operator. This is because the size of the returned overlay may increase in future releases of CS/AIX; using the returned overlay size ensures that your application will continue to work with future releases.

**mode\_def\_summary.mode\_name**

Mode name. This is an 8-byte type-A EBCDIC string, padded on the right with spaces if the name is shorter than 8 characters.

**mode\_def\_summary.description**

A null-terminated text string describing the mode, as specified in the definition of the mode.

**mode\_def\_detail.overlay\_size**

The size of the returned *mode\_def\_detail* structure, and therefore the offset to the start of the next entry in the data buffer.

When your application needs to go through the returned buffer to find each *mode\_def\_detail* structure in turn, it must use this value to move to the correct offset for the next data structure, and must not use the C `sizeof()` operator. This is because the size of the returned overlay may increase in future releases of CS/AIX; using the returned overlay size ensures that your application will continue to work with future releases.

**mode\_def\_detail.mode\_name**

Mode name. This is an 8-byte type-A EBCDIC string, padded on the right with spaces if the name is shorter than 8 characters.

**mode\_def\_detail.mode\_chars.description**

A null-terminated text string describing the mode, as specified in the definition of the mode.

**mode\_def\_detail.mode\_chars.max\_ru\_size\_upp**

Upper boundary for the maximum RU size to be used on sessions with this mode name. The value is used when the maximum RU size is negotiated during session activation.

Range: 256-61,440. This field is ignored if the *default\_ru\_size* parameter (see below) is set to *AP\_YES*.

**mode\_def\_detail.mode\_chars.receive\_pacing\_win**

Session pacing window for sessions using this mode. For fixed pacing, this is the maximum number of frames that can be received from the partner LU before the local LU must send a response; for adaptive pacing, this value is used as an initial receive window size. CS/AIX always uses adaptive pacing unless the adjacent node specifies that it is not supported.

Range is 1-63, or zero to specify no pacing window (that is, an unlimited number of frames can be received, and no response is required).

**mode\_def\_detail.mode\_chars.default\_ru\_size**

Specifies whether a default upper bound for the maximum RU size will be used. Possible values are:

**AP\_YES**

CS/AIX ignores the *max\_ru\_size\_upp* parameter, and sets the upper bound for the maximum RU size to the largest value that can be accommodated in the link BTU size.

### **AP\_NO**

CS/AIX uses the *max\_ru\_size\_upp* parameter to define the maximum RU size.

### ***mode\_def\_detail.mode\_chars.max\_neg\_sess\_lim***

Maximum number of sessions allowed on this mode between any local LU and partner LU. Range: 1-32,767, or zero to specify no implicit CNOS exchange.

### ***mode\_def\_detail.mode\_chars.plu\_mode\_session\_limit***

Default session limit for this mode. This limits the number of sessions on this mode between any one local LU and partner LU pair. This value is used when CNOS (Change Number of Sessions) exchange is initiated implicitly. Range: 1-32,767, or zero to specify no implicit CNOS exchange.

### ***mode\_def\_detail.mode\_chars.min\_conwin\_src***

Minimum number of contention winner sessions that a local LU using this mode can activate. This value is used when CNOS (Change Number of Sessions) exchange is initiated implicitly. Range: 1-32,767, or zero to specify no implicit CNOS exchange.

### ***mode\_def\_detail.mode\_chars.cos\_name***

Name of the class of service to request when activating sessions on this mode. This is an 8-byte type-A EBCDIC string, padded on the right with spaces if the name is shorter than 8 characters.

### ***mode\_def\_detail.mode\_chars.compression***

Specifies whether sessions activated using this mode can use compression. Possible values are:

#### **AP\_COMP\_PROHIBITED**

Compression is not supported for sessions using this mode.

#### **AP\_COMP\_REQUESTED**

Compression is supported and requested for sessions using this mode. (It is not mandatory; compression will not be used if the BIND from the partner does not request it.)

### ***mode\_def\_detail.mode\_chars.auto\_act***

Specifies how many sessions will be activated automatically for this mode. This value is used when CNOS (Change Number of Sessions) exchange is initiated implicitly. This value is in the range 0-32,767.

### ***mode\_def\_detail.mode\_chars.min\_conloser\_src***

Minimum number of contention loser sessions that can be activated by any one local LU that uses this mode. This value is used when CNOS (Change Number of Sessions) exchange is initiated implicitly. This value is in the range 0-32,767.

### ***mode\_def\_detail.mode\_chars.max\_ru\_size\_low***

Lower bound for the maximum size of RUs sent and received on sessions that use this mode.

This value is in the range 256-61,440 or zero, which means that there is no lower bound.

### ***mode\_def\_detail.mode\_chars.max\_receive\_pacing\_win***

Maximum session pacing window for sessions in this mode. For adaptive pacing, this value is used to limit the receive pacing window that the session will grant. For fixed pacing, this parameter is not used. (CS/AIX always uses adaptive pacing unless the adjacent node specifies that it does not support it.)

This value is in the range 0-32,767 or zero, which means there is no limit for the pacing window.

### ***mode\_def\_detail.mode\_chars.max\_compress\_lvl***

Specifies the maximum level of compression that CS/AIX will attempt to negotiate for data flowing from the local node. Possible values are:

- AP\_NONE
- AP\_RLE\_COMPRESSION
- AP\_LZ9\_COMPRESSION
- AP\_LZ10\_COMPRESSION

If compression is negotiated using a non-extended BIND, which does not specify a maximum compression level, RLE compression will be used.

**mode\_def\_detail.mode\_chars.max\_decompress\_lvl**

Specifies the maximum level of decompression that CS/AIX will attempt to negotiate for data flowing into the local node. Possible values are:

- AP\_NONE
- AP\_RLE\_COMPRESSION
- AP\_LZ9\_COMPRESSION
- AP\_LZ10\_COMPRESSION

If compression is negotiated using a non-extended BIND, which does not specify a maximum compression level, RLE compression will be used.

**Returned parameters: parameter check**

If the verb does not execute because of a parameter error, CS/AIX returns the following parameters:

**primary\_rc**

AP\_PARAMETER\_CHECK

**secondary\_rc**

Possible values are:

**AP\_INVALID\_MODE\_NAME**

The *list\_options* parameter was set to AP\_LIST\_INCLUSIVE to list all entries starting from the supplied name, but the *mode\_name* parameter was not valid.

**AP\_INVALID\_LIST\_OPTION**

The *list\_options* parameter was not set to a valid value.

Appendix B, “Common return codes,” on page 661 lists further secondary return codes associated with AP\_PARAMETER\_CHECK, which are common to all NOF verbs.

**Returned parameters: other conditions**

Appendix B, “Common return codes,” on page 661 lists further combinations of primary and secondary return codes that are common to all NOF verbs.

**QUERY\_MODE\_TO\_COS\_MAPPING**

QUERY\_MODE\_TO\_COS\_MAPPING returns information about the COS (class of service) associated with a particular mode. This verb can be used to obtain information about a specific mode or about multiple modes, depending on the options used.

This verb must be issued to a running node.

**VCB structure**

```
typedef struct query_mode_to_cos_mapping
{
    AP_UINT16      opcode;                /* verb operation code      */
    unsigned char  reserv2;               /* reserved                  */
    unsigned char  format;                /* reserved                  */
    AP_UINT16      primary_rc;            /* primary return code      */
    AP_UINT32      secondary_rc;          /* secondary return code    */
    unsigned char  *buf_ptr;              /* pointer to buffer        */
    AP_UINT32      buf_size;              /* buffer size              */
    AP_UINT32      total_buf_size;        /* total buffer size required */
    AP_UINT16      num_entries;           /* number of entries        */
    AP_UINT16      total_num_entries;     /* total number of entries  */
    unsigned char  list_options;          /* listing options          */
    unsigned char  reserv3;               /* reserved                  */
    unsigned char  mode_name[8];          /* mode name                 */
} QUERY_MODE_TO_COS_MAPPING;
```

```
typedef struct mode_to_cos_mapping_data
{
    AP_UINT16      overlay_size;          /* size of returned entry    */
    unsigned char  mode_name[8];         /* mode name                  */
    unsigned char  cos_name[8];         /* cos name                   */
    unsigned char  reserva[20];         /* reserved                   */
} MODE_TO_COS_MAPPING_DATA;
```

## Supplied parameters

The application supplies the following parameters:

***opcode***

AP\_QUERY\_MODE\_TO\_COS\_MAPPING

***buf\_ptr***

A pointer to a data buffer that CS/AIX will use to return the requested information.

***buf\_size***

Size of the supplied data buffer.

***num\_entries***

Maximum number of modes for which data should be returned. To request data for a specific mode rather than a range, specify the value 1. To return as many entries as possible, specify zero; in this case, CS/AIX will return the maximum number of entries that can be accommodated in the supplied data buffer.

***list\_options***

The position in the list of modes from which CS/AIX should begin to return data. Possible values are:

**AP\_FIRST\_IN\_LIST**

Start at the first entry in the list.

**AP\_LIST\_INCLUSIVE**

Start at the entry specified by the *mode\_name* parameter.

**AP\_LIST\_FROM\_NEXT**

Start at the entry immediately following the entry specified by the *mode\_name* parameter.

For more information about how the list is ordered and how the application can obtain specific entries from it, see [“List options for QUERY\\_\\* Verbs”](#) on page 33.

***mode\_name***

Mode name for which information is required, or the name to be used as an index into the list. This value is ignored if *list\_options* is set to AP\_FIRST\_IN\_LIST.

The mode name is an 8-byte type-A EBCDIC string, padded on the right with spaces if the name is shorter than 8 characters. To return information about the default COS that is used for any unrecognized mode names, set this parameter to 8 binary zeros.

## Returned parameters: successful execution

If the verb executes successfully, CS/AIX returns the following parameters:

***primary\_rc***

AP\_OK

***buf\_size***

Length of the information returned in the supplied buffer.

***total\_buf\_size***

Returned value indicating the size of buffer that would have been required to return all the list information requested. A value greater than *buf\_size* indicates that not all the available entries were returned.

***num\_entries***

Number of entries returned in the data buffer.

**total\_num\_entries**

Total number of entries available. A value greater than *num\_entries* indicates that not all the available entries were returned.

Each entry in the data buffer consists of the following parameters:

**mode\_to\_cos\_mapping\_data.overlay\_size**

The size of the returned *mode\_to\_cos\_mapping\_data* structure, and therefore the offset to the start of the next entry in the data buffer.

When your application needs to go through the returned buffer to find each *mode\_to\_cos\_mapping\_data* structure in turn, it must use this value to move to the correct offset for the next data structure, and must not use the C `sizeof()` operator. This is because the size of the returned overlay may increase in future releases of CS/AIX; using the returned overlay size ensures that your application will continue to work with future releases.

**mode\_to\_cos\_mapping\_data.mode\_name**

Mode name. This is an 8-byte type-A EBCDIC string, padded on the right with spaces if the name is shorter than 8 characters.

**mode\_to\_cos\_mapping\_data.cos\_name**

Class of service name associated with the mode name. This is an 8-byte type-A EBCDIC string, padded on the right with spaces if the name is shorter than 8 characters.

## Returned parameters: parameter check

If the verb does not execute because of a parameter error, CS/AIX returns the following parameters:

**primary\_rc**

AP\_PARAMETER\_CHECK

**secondary\_rc**

Possible values are:

**AP\_INVALID\_MODE\_NAME**

The *list\_options* parameter was set to AP\_LIST\_INCLUSIVE to list all entries starting from the supplied name, but the *mode\_name* parameter was not valid.

**AP\_INVALID\_LIST\_OPTION**

The *list\_options* parameter was not set to a valid value.

Appendix B, “Common return codes,” on page 661 lists further secondary return codes associated with AP\_PARAMETER\_CHECK, which are common to all NOF verbs.

## Returned parameters: other conditions

Appendix B, “Common return codes,” on page 661 lists further combinations of primary and secondary return codes that are common to all NOF verbs.

## QUERY\_NMVT\_APPLICATION

---

QUERY\_NMVT\_APPLICATION returns a list of applications that have registered for NMVT-level messages by issuing the MS verb REGISTER\_NMVT\_APPLICATION. For more information about this verb, see the *IBM Communications Server for Data Center Deployment on AIX or Linux MS Programmer's Guide*.

This verb can be used to obtain information about a specific application or about multiple applications, depending on the options used.

This verb must be issued to a running node.

## VCB structure

```
typedef struct query_nmvt_application
{
    AP_UINT16          opcode;          /* Verb operation code */
}
```

## QUERY\_NMVT\_APPLICATION

```
    unsigned char    reserv2;                /* reserved          */
    unsigned char    format;                 /* reserved          */
    AP_UINT16        primary_rc;             /* primary return code */
    AP_UINT32        secondary_rc;          /* secondary return code */
    unsigned char    *buf_ptr;               /* pointer to buffer  */
    AP_UINT32        buf_size;              /* buffer size        */
    AP_UINT32        total_buf_size;        /* total buffer size required*/
    AP_UINT16        num_entries;           /* number of entries  */
    AP_UINT16        total_num_entries;     /* total number of entries */
    unsigned char    list_options;          /* listing options    */
    unsigned char    reserv3;               /* reserved           */
    unsigned char    application[8];        /* application         */
} QUERY_NMVT_APPLICATION;
```

```
typedef struct nmvt_application_data
{
    AP_UINT16        overlay_size;           /* size of returned entry */
    unsigned char    application[8];        /* application name        */
    AP_UINT16        ms_vector_key_type;    /* MS vector key accepted
                                           /* by appl                */
    unsigned char    conversion_required;    /* is conversion to MDS_MU
                                           /* required                */
    unsigned char    reserv[5];             /* reserved                */
    unsigned char    reserva[20];          /* reserved                */
} NMVT_APPLICATION_DATA;
```

## Supplied parameters

The application supplies the following parameters:

### ***opcode***

AP\_QUERY\_NMVT\_APPLICATION

### ***buf\_ptr***

A pointer to a data buffer that CS/AIX will use to return the requested information.

### ***buf\_size***

Size of the supplied data buffer.

### ***num\_entries***

Maximum number of applications for which data should be returned. To request data for a specific application rather than a range, specify the value 1. To return as many entries as possible, specify zero; in this case, CS/AIX will return the maximum number of entries that can be accommodated in the supplied data buffer.

### ***list\_options***

The position in the list of applications from which CS/AIX should begin to return data. Possible values are:

#### **AP\_FIRST\_IN\_LIST**

Start at the first entry in the list.

#### **AP\_LIST\_INCLUSIVE**

Start at the entry specified by the application parameter.

#### **AP\_LIST\_FROM\_NEXT**

Start at the entry immediately following the entry specified by the application parameter.

For more information about how the list is ordered and how the application can obtain specific entries from it, see [“List options for QUERY\\_\\* Verbs” on page 33](#).

### ***application***

Application name. This parameter is ignored if *list\_options* is set to AP\_FIRST\_IN\_LIST. The name is an 8-byte type-A EBCDIC string, padded on the right with spaces if the name is shorter than 8 characters.

## Returned parameters: successful execution

If the verb executes successfully, CS/AIX returns the following parameters:



**primary\_rc**

AP\_OK

**buf\_size**

Length of the information returned in the supplied buffer.

**total\_buf\_size**

Returned value indicating the size of buffer that would have been required to return all the list information requested. A value greater than *buf\_size* indicates that not all the available entries were returned.

**num\_entries**

Number of entries returned in the data buffer.

**total\_num\_entries**

Total number of entries available. A value greater than *num\_entries* indicates that not all the available entries were returned.

Each entry in the data buffer consists of the following parameters:

**nmvt\_application\_data.overlay\_size**

The size of the returned *nmvt\_application\_data* structure, and therefore the offset to the start of the next entry in the data buffer.

When your application needs to go through the returned buffer to find each *nmvt\_application\_data* structure in turn, it must use this value to move to the correct offset for the next data structure, and must not use the C `sizeof()` operator. This is because the size of the returned overlay may increase in future releases of CS/AIX; using the returned overlay size ensures that your application will continue to work with future releases.

**nmvt\_application\_data.application**

Name of the registered application. This is an 8-byte type-A EBCDIC string, padded on the right with spaces if the name is shorter than 8 characters.

**nmvt\_application\_data.ms\_vector\_key\_type**

MS vector key accepted by the application. When the application registers for NMVT messages, it specifies which MS vector keys it will accept.

**nmvt\_application\_data.conversion\_required**

Specifies whether the registered application requires incoming messages to be converted from NMVT to MDS\_MU format. When the application registers for NMVT messages, it specifies whether this conversion is required. Possible values are:

**AP\_YES**

Incoming messages are converted to MDS\_MU format.

**AP\_NO**

Incoming messages are not converted.

## Returned parameters: parameter check

If the verb does not execute because of a parameter error, CS/AIX returns the following parameters:

**primary\_rc**

AP\_PARAMETER\_CHECK

**secondary\_rc**

Possible values are:

**AP\_INVALID\_APPLICATION\_NAME**

The *list\_options* parameter was set to AP\_LIST\_INCLUSIVE to list all entries starting from the supplied name, but the application parameter was not valid.

**AP\_INVALID\_LIST\_OPTION**

The *list\_options* parameter was not set to a valid value.

Appendix B, "Common return codes," on page 661 lists further secondary return codes associated with AP\_PARAMETER\_CHECK, which are common to all NOF verbs.

## Returned parameters: other conditions

Appendix B, “Common return codes,” on page 661 lists further combinations of primary and secondary return codes that are common to all NOF verbs.

## QUERY\_NN\_TOPOLOGY\_NODE

Each network node maintains a network topology database which holds information about all the network nodes, virtual routing nodes (VRNs), and network node to network node TGs in the network. QUERY\_NN\_TOPOLOGY\_NODE returns information about the network node and VRN entries in this database.

This verb can be used to obtain either summary or detailed information, about a specific node or about multiple nodes, depending on the options used. It can be issued only to a network node; it is not valid at an end node or a LEN node.

This verb must be issued to a running node.

## VCB structure

```
typedef struct query_nn_topology_node
{
    AP_UINT16      opcode;           /* verb operation code          */
    unsigned char  reserv2;          /* reserved                      */
    unsigned char  format;           /* reserved                      */
    AP_UINT16      primary_rc;       /* primary return code          */
    AP_UINT32      secondary_rc;     /* secondary return code        */
    unsigned char  *buf_ptr;         /* pointer to buffer            */
    AP_UINT32      buf_size;         /* buffer size                   */
    AP_UINT32      total_buf_size;   /* total buffer size required   */
    AP_UINT16      num_entries;      /* number of entries            */
    AP_UINT16      total_num_entries; /* total number of entries      */
    unsigned char  list_options;     /* listing options              */
    unsigned char  reserv3;          /* reserved                      */
    unsigned char  node_name[17];    /* network qualified node name  */
    unsigned char  node_type;        /* node type                     */
    AP_UINT32      frsn;             /* flow reduction sequence number */
} QUERY_NN_TOPOLOGY_NODE;
```

If the *frsn* field is set to a non-zero value then only node entries with FRSNs equal to or greater than the one specified will be returned. If it is set to zero then all node entries are returned.

```
typedef struct nn_topology_node_summary
{
    AP_UINT16      overlay_size;     /* size of returned entry       */
    unsigned char  node_name[17];    /* network qualified node name  */
    unsigned char  node_type;        /* node type                     */
} NN_TOPOLOGY_NODE_SUMMARY;
```

```
typedef struct nn_topology_node_detail
{
    AP_UINT16      overlay_size;     /* size of returned entry       */
    unsigned char  node_name[17];    /* network qualified node name  */
    unsigned char  node_type;        /* node type                     */
    AP_UINT16      days_left;        /* days left until entry purged */
    unsigned char  reserv1[2];       /* reserved                      */
    AP_UINT32      frsn;             /* flow reduction sequence number */
    AP_UINT32      rsn;              /* resource sequence number     */
    unsigned char  rar;              /* route additional resistance   */
    unsigned char  status;           /* node status                   */
    unsigned char  function_support; /* function support              */
    unsigned char  reserv2;          /* reserved                      */
    unsigned char  branch_aware;     /* is the node branch aware?    */
    unsigned char  reserva[19];      /* reserved                      */
} NN_TOPOLOGY_NODE_DETAIL;
```

## Supplied parameters

The application supplies the following parameters:

**opcode**

AP\_QUERY\_NN\_TOPOLOGY\_NODE

**buf\_ptr**

A pointer to a data buffer that CS/AIX will use to return the requested information.

**buf\_size**

Size of the supplied data buffer.

**num\_entries**

Maximum number of nodes for which data should be returned. To request data for a specific node rather than a range, specify the value 1. To return as many entries as possible, specify zero; in this case, CS/AIX will return the maximum number of entries that can be accommodated in the supplied data buffer.

**list\_options**

The position in the list from which CS/AIX should begin to return data, and the level of information required for each entry. Specify the level of information with one of the following values:

**AP\_SUMMARY**

Summary information only.

**AP\_DETAIL**

Detailed information.

Combine this value using a logical OR operation with one of the following values:

**AP\_FIRST\_IN\_LIST**

Start at the first entry in the list.

**AP\_LIST\_INCLUSIVE**

Start at the entry specified by the combination of the *node\_name*, *node\_type*, and *frsn* parameters.

**AP\_LIST\_FROM\_NEXT**

Start at the entry immediately following the entry specified by the combination of the *node\_name*, *node\_type*, and *frsn* parameters.

The list is ordered by *node\_name*, then by *node\_type* (in the order AP\_NETWORK\_NODE, AP\_VRN), and lastly in numerical order of *frsn*. For more information about how the list is ordered and how the application can obtain specific entries from it, see [“List options for QUERY\\_\\* Verbs” on page 33](#).

**node\_name**

Fully qualified name of the node for which information is required, or the name to be used as an index into the list of nodes. This value is ignored if *list\_options* is set to AP\_FIRST\_IN\_LIST

The name is a 17-byte EBCDIC string, right-padded with EBCDIC spaces. It consists of a network ID of up to 8 A-string characters, an EBCDIC dot (period) character, and a network name of up to 8 A-string characters.

**node\_type**

Type of the node. This value is ignored if *list\_options* is set to AP\_FIRST\_IN\_LIST. Possible values are:

**AP\_NETWORK\_NODE**

Network node.

**AP\_VRN**

Virtual routing node.

**AP\_LEARN\_NODE**

Node type is unknown.

**frsn**

Flow Reduction Sequence Number (FRSN). Specify zero to return information about all nodes, or a nonzero value to return information about nodes with a FRSN greater than or equal to this value.

## QUERY\_NN\_TOPOLOGY\_NODE

This parameter can be used to ensure that consistent information is obtained when the application needs to issue several verbs to obtain all the information. The application should take the following steps:

To Obtain Consistent Information Using the *frsn* Parameter

1. Issue QUERY\_NODE to get the node's current FRSN.
2. Issue as many QUERY\_NN\_TOPOLOGY\_NODE verbs as necessary to get all the database entries, with the *frsn* parameter set to zero.
3. Issue QUERY\_NODE again and compare the new FRSN with the one returned in step 1.
4. If the two FRSNs are different, the database has changed. Add 1 to the FRSN obtained in step 1, and issue further QUERY\_NN\_TOPOLOGY\_NODE verbs with the *frsn* parameter set to this new value. These verbs will return only the entries that have changed.

### Returned parameters: successful execution

If the verb executes successfully, CS/AIX returns the following parameters:

***primary\_rc***

AP\_OK

***buf\_size***

Length of the information returned in the supplied buffer.

***total\_buf\_size***

Returned value indicating the size of buffer that would have been required to return all the list information requested. A value greater than *buf\_size* indicates that not all the available entries were returned.

***num\_entries***

Number of entries returned in the data buffer.

***total\_num\_entries***

Total number of entries available. A value greater than *num\_entries* indicates that not all the available entries were returned.

Each entry in the data buffer consists of the following parameters:

***nn\_topology\_node\_summary.overlay\_size***

The size of the returned *nn\_topology\_node\_summary* structure, and therefore the offset to the start of the next entry in the data buffer.

When your application needs to go through the returned buffer to find each *nn\_topology\_node\_summary* structure in turn, it must use this value to move to the correct offset for the next data structure, and must not use the C `sizeof()` operator. This is because the size of the returned overlay may increase in future releases of CS/AIX; using the returned overlay size ensures that your application will continue to work with future releases.

***nn\_topology\_node\_summary.node\_name***

Fully qualified name of the node. This is a 17-byte EBCDIC string, padded on the right with EBCDIC spaces. It consists of a network ID of 1-8 A-string characters, an EBCDIC dot (period) character, and a network name of 1-8 A-string characters.

***nn\_topology\_node\_summary.node\_type***

Type of the node. This is one of the following:

**AP\_NETWORK\_NODE**

Network node.

**AP\_END\_NODE**

End node.

**AP\_VRN**

Virtual routing node.

***nn\_topology\_node\_detail.node\_name***

Fully qualified name of the node. This is a 17-byte EBCDIC string, padded on the right with EBCDIC spaces. It consists of a network ID of 1-8 A-string characters, an EBCDIC dot (period) character, and a network name of 1-8 A-string characters.

***nn\_topology\_node\_detail.node\_type***

Type of the node. This is one of the following:

**AP\_NETWORK\_NODE**

Network node.

**AP\_END\_NODE**

End node.

**AP\_VRN**

Virtual routing node.

***nn\_topology\_node\_detail.overlay\_size***

The size of the returned `nn_topology_node_detail` structure, and therefore the offset to the start of the next entry in the data buffer.

When your application needs to go through the returned buffer to find each `nn_topology_node_detail` structure in turn, it must use this value to move to the correct offset for the next data structure, and must not use the C `sizeof()` operator. This is because the size of the returned overlay may increase in future releases of CS/AIX; using the returned overlay size ensures that your application will continue to work with future releases.

***nn\_topology\_node\_detail.days\_left***

Number of days before this node entry will be deleted from the Topology Database. For the local node entry, this value is set to zero, indicating that this entry is never deleted.

***nn\_topology\_node\_detail.frsn***

Flow Reduction Sequence Number (FRSN). Indicates the last time that this resource was updated at the local node.

***nn\_topology\_node\_detail.rsn***

Resource Sequence Number. This is assigned by the network node that owns this resource.

***nn\_topology\_node\_detail.rar***

The node's route additional resistance. Values are in the range 0-255.

***nn\_topology\_node\_detail.status***

Specifies the status of the node. This parameter may be set to `AP_UNCONGESTED`, to any one of the other values listed, or to two or more of the other values combined using a logical OR. Possible values are:

**AP\_UNCONGESTED**

The number of ISR sessions is below the `isr_sessions_upper_threshold` value in the node's configuration.

**AP\_CONGESTED**

The number of ISR sessions exceeds the threshold value.

**AP\_IRR\_DEPLETED**

The number of ISR sessions has reached the maximum specified for the node.

**AP\_ERR\_DEPLETED**

The number of endpoint sessions has reached the maximum specified.

**AP\_QUIESCING**

A `STOP_NODE` of type `AP_QUIESCE` or `AP_QUIESCE_ISR` has been issued.

***nn\_topology\_node\_detail.function\_support***

Specifies which functions are supported. This may be one or more of the following, combined using a logical OR.

**AP\_BORDER\_NODE**

Border Node

## QUERY\_NN\_TOPOLOGY\_NODE

### AP\_EXTENDED\_BORDER\_NODE

Return border node function is supported.

### AP\_CDS

Central Directory server

### AP\_GATEWAY

Gateway Node

### AP\_INTERCHANGE\_NODE

Interchange node function is supported.

### AP\_ISR

Intermediate Session Routing.

### AP\_HPR

Node supports the base functions of High Performance Routing (HPR).

### AP\_RTP\_TOWER

Node supports the Rapid Transport Protocol tower of HPR.

### AP\_CONTROL\_OVER\_RTP\_TOWER

Node supports HPR control flows over the Rapid Transport Protocol tower.

### *nn\_topology\_node\_detail.branch\_aware*

Specifies whether the node supports branch awareness, APPN Option Set 1120.

### AP\_NO

The node does not support option set 1120.

### AP\_YES

The node supports option set 1120.

## Returned parameters: parameter check

If the verb does not execute because of a parameter error, CS/AIX returns the following parameters:

### *primary\_rc*

AP\_PARAMETER\_CHECK

### *secondary\_rc*

Possible values are:

#### AP\_INVALID\_NODE

The *list\_options* parameter was set to AP\_LIST\_INCLUSIVE to list all entries starting from the supplied name, but the *node\_name* parameter was not valid.

#### AP\_INVALID\_LIST\_OPTION

The *list\_options* parameter was not set to a valid value.

Appendix B, “Common return codes,” on page 661 lists further secondary return codes associated with AP\_PARAMETER\_CHECK, which are common to all NOF verbs.

## Returned parameters: function not supported

If the verb does not execute successfully because the local node is not a network node, CS/AIX returns the following parameters:

### *primary\_rc*

#### AP\_FUNCTION\_NOT\_SUPPORTED

The local node is not a network node. This verb can be used only at a network node.

## Returned parameters: other conditions

Appendix B, “Common return codes,” on page 661 lists further combinations of primary and secondary return codes that are common to all NOF verbs.

## QUERY\_NN\_TOPOLOGY\_STATS

QUERY\_NN\_TOPOLOGY\_STATS returns statistical information about the topology database. It can be used only if the CS/AIX node is a network node, and is not valid if it is an end node.

This verb must be issued to a running node.

### VCB structure

```
typedef struct query_nn_topology_stats
{
    AP_UINT16      opcode;                /* verb operation code          */
    unsigned char  reserv2;               /* reserved                     */
    unsigned char  format;                /* reserved                     */
    AP_UINT16      primary_rc;            /* primary return code          */
    AP_UINT32      secondary_rc;          /* secondary return code        */
    AP_UINT32      max_nodes;             /* max number of nodes in database */
    AP_UINT32      cur_num_nodes;         /* current number of nodes in database */
    AP_UINT32      node_in_tdus;          /* number of TDUs received      */
    AP_UINT32      node_out_tdus;         /* number of TDUs sent          */
    AP_UINT32      node_low_rsns;         /* node updates received with low RSNs */
    AP_UINT32      node_equal_rsns;       /* node updates in with equal RSNs */
    AP_UINT32      node_good_high_rsns;   /* node updates in with high RSNs */
    AP_UINT32      node_bad_high_rsns;    /* node updates in with high and odd RSNs */
    AP_UINT32      node_state_updates;    /* number of node updates sent  */
    AP_UINT32      node_errors;           /* number of node entry errors found */
    AP_UINT32      node_timer_updates;    /* number of node records built due to timer updates */
    AP_UINT32      node_purges;           /* number of node records purged */
    AP_UINT32      tg_low_rsns;           /* TG updates received with low RSNs */
    AP_UINT32      tg_equal_rsns;         /* TG updates in with equal RSNs */
    AP_UINT32      tg_good_high_rsns;     /* TG updates in with high RSNs */
    AP_UINT32      tg_bad_high_rsns;      /* TG updates in with high and odd RSNs */
    AP_UINT32      tg_state_updates;      /* number of TG updates sent    */
    AP_UINT32      tg_errors;             /* number of TG entry errors found */
    AP_UINT32      tg_timer_updates;      /* number of node records built due to timer updates */
    AP_UINT32      tg_purges;             /* number of node records purged */
    AP_UINT32      total_route_calcs;     /* number of routes calculated for COS */
    AP_UINT32      total_route_rejs;      /* number of failed route calculations */
    AP_UINT32      total_tree_cache_hits; /* total number of tree cache hits */
    AP_UINT32      total_tree_cache_misses; /* total number of tree cache misses */
    AP_UINT32      total_tdu_wars;        /* total number TDU war detections */
    unsigned char  reserva[16];          /* reserved                     */
} QUERY_NN_TOPOLOGY_STATS;
```

### Supplied parameters

The application supplies the following parameter:

#### *opcode*

AP\_QUERY\_NN\_TOPOLOGY\_STATS

### Returned parameters: successful execution

If the verb executes successfully, CS/AIX returns the following parameters:

#### *primary\_rc*

AP\_OK

#### *max\_nodes*

Maximum number of node records in the Topology Database. This value was specified on DEFINE\_NODE. A value of zero indicates no limit.

### ***cur\_num\_nodes***

Current number of nodes in this node's topology database. If this value exceeds the maximum number of nodes allowed, an Alert is issued.

### ***node\_in\_tdus***

Total number of Topology Database Updates (TDUs) received by this node.

### ***node\_out\_tdus***

Total number of Topology Database Updates (TDUs) built by this node to be sent to all adjacent network nodes since the last initialization.

### ***node\_low\_rsns***

Total number of topology node updates received by this node with RSN less than the current RSN. Both even and odd RSNs are included in this count. (These TDUs are not errors, but result when TDUs are broadcast to all adjacent network nodes. No update to this node's topology database occurs, but this node will send a TDU with its higher RSN to the adjacent node that sent this low RSN.)

### ***node\_equal\_rsns***

Total number of topology node updates received by this node with RSN equal to the current RSN. Both even and odd RSNs are included in this count. (These TDUs are not errors, but result when TDUs are broadcast to all adjacent network nodes. No update to this node's topology database occurs.)

### ***node\_good\_high\_rsns***

Total number of topology node updates received by this node with RSN greater than the current RSN. The node updates its topology and broadcasts a TDU to all adjacent network nodes. It is not required to send a TDU to the sender of this update because that node already has the update.

### ***node\_bad\_high\_rsns***

Total number of topology node updates received by this node with an odd RSN greater than the current RSN. These updates represent a topology inconsistency detected by one of the APPN network nodes. The node updates its topology and broadcasts the TDU to all adjacent network nodes.

### ***node\_state\_updates***

Total number of topology node updates built as a result of internally detected node state changes that affect APPN topology and routing. Updates are sent via TDUs to all adjacent network nodes.

### ***node\_errors***

Total number of topology node update inconsistencies detected by this node. This occurs when this node attempts to update its topology database and detects a data inconsistency. This node will create a TDU with the current RSN incremented to the next odd number and broadcast it to all adjacent network nodes.

### ***node\_timer\_updates***

Total number of topology node updates built for this node's resource due to timer updates. Updates are sent via TDUs to all adjacent network nodes. These updates ensure that other network nodes do not delete this node's resource from their topology database.

### ***node\_purges***

Total number of topology node records purged from this node's topology database. This occurs when a node record has not been updated in a specified amount of time. The owning node is responsible for broadcasting updates for its resource that it wants kept in the network topology.

### ***tg\_low\_rsns***

Total number of topology TG updates received by this node with RSN less than the current RSN. Both even and odd RSNs are included in this count. (These TDUs are not errors, but result when TDUs are broadcast to all adjacent network nodes. No update to this node's topology database occurs, but this node will send a TDU with its higher RSN to the adjacent node that sent this low RSN.)

### ***tg\_equal\_rsns***

Total number of topology TG updates received by this node with RSN equal to the current RSN. Both even and odd RSNs are included in this count. (These TDUs are not errors, but result when TDUs are broadcast to all adjacent network nodes. No update to this node's topology database occurs.)

### ***tg\_good\_high\_rsns***

Total number of topology TG updates received by this node with RSN greater than the current RSN. The node updates its topology and broadcasts a TDU to all adjacent network nodes.



***tg\_bad\_high\_rsns***

Total number of topology TG updates received by this node with an odd RSN greater than the current RSN. These updates represent a topology inconsistency detected by one of the APPN network nodes. The node updates its topology and broadcasts the TDU to all adjacent network nodes.

***tg\_state\_updates***

Total number of topology TG updates built as a result of internally detected node state changes that affect APPN topology and routing. Updates are sent via TDUs to all adjacent network nodes.

***tg\_errors***

Total number of topology TG update inconsistencies detected by this node. This occurs when this node attempts to update its topology database and detects a data inconsistency. This node will create a TDU with the current RSN incremented to the next odd number and broadcast it to all adjacent network nodes.

***tg\_timer\_updates***

Total number of topology TG updates built for this node's resource due to timer updates. Updates are sent via TDUs to all adjacent network nodes. These updates ensure that other network nodes do not delete this node's resource from their topology database.

***tg\_purges***

Total number of topology TG records purged from this node's topology database. This occurs when a TG record has not been updated in a specified amount of time. The owning node is responsible for broadcasting updates for its resource that it wants kept in the network topology.

***total\_route\_calcs***

Number of routes calculated for all class of services since the last initialization.

***total\_route\_rejs***

Number of route requests for all class of services that could not be calculated since the last initialization.

***total\_tree\_cache\_hits***

Number of route computations that were satisfied by a cached routing tree. This number may be greater than the total number of computed routes, since each route may require inspection of several trees.

***total\_tree\_cache\_misses***

Number of route computations that were not satisfied by a cached routing tree, so that a new routing tree had to be built.

***total\_tdu\_wars***

Number of TDU wars the local node has detected and prevented.

## Returned parameters: function not supported

If the verb does not execute successfully because the local node is not a network node, CS/AIX returns the following parameters:

***primary\_rc*****AP\_FUNCTION\_NOT\_SUPPORTED**

The local node is not a network node. This verb can be used only at a network node.

## Returned parameters: other conditions

Appendix B, "Common return codes," on page 661 lists further combinations of primary and secondary return codes that are common to all NOF verbs.

## QUERY\_NN\_TOPOLOGY\_TG

---

Each network node maintains a network topology database which holds information about all the network nodes, VRNs and network node to network node TGs in the network. QUERY\_NN\_TOPOLOGY\_TG returns information about the TG entries in this database.

## QUERY\_NN\_TOPOLOGY\_TG

This verb can be used to obtain either summary or detailed information, about a specific TG or about multiple TGs, depending on the options used. It can be issued only to a network node; it is not valid at an end node or a LEN node.

This verb must be issued to a running node.

## VCB structure

```
typedef struct query_nn_topology_tg
{
    AP_UINT16      opcode;           /* verb operation code          */
    unsigned char  reserv2;          /* reserved                      */
    unsigned char  format;           /* reserved                      */
    AP_UINT16      primary_rc;       /* primary return code          */
    AP_UINT32      secondary_rc;     /* secondary return code        */
    unsigned char  *buf_ptr;         /* pointer to buffer            */
    AP_UINT32      buf_size;         /* buffer size                  */
    AP_UINT32      total_buf_size;   /* total buffer size required   */
    AP_UINT16      num_entries;      /* number of entries            */
    AP_UINT16      total_num_entries; /* total number of entries      */
    unsigned char  list_options;     /* listing options              */
    unsigned char  reserv3;          /* reserved                      */
    unsigned char  owner[17];        /* node that owns the TG        */
    unsigned char  owner_type;       /* type of node that owns the TG */
    unsigned char  dest[17];         /* TG destination node          */
    unsigned char  dest_type;        /* TG destination node type     */
    unsigned char  tg_num;           /* TG number                    */
    unsigned char  reserv1;          /* reserved                      */
    AP_UINT32      frsn;             /* flow reduction sequence number */
} QUERY_NN_TOPOLOGY_TG;
```

```
typedef struct topology_tg_summary
{
    AP_UINT16      overlay_size;     /* size of returned entry       */
    unsigned char  owner[17];        /* node that owns the TG        */
    unsigned char  owner_type;       /* type of node that owns the TG */
    unsigned char  dest[17];         /* TG destination node          */
    unsigned char  dest_type;        /* TG destination node type     */
    unsigned char  tg_num;           /* TG number                    */
    unsigned char  reserv3[1];       /* reserved                      */
    AP_UINT32      frsn;             /* flow reduction sequence number */
} TOPOLOGY_TG_SUMMARY;
```

```
typedef struct topology_tg_detail
{
    AP_UINT16      overlay_size;     /* size of returned entry       */
    unsigned char  owner[17];        /* node that owns the TG        */
    unsigned char  owner_type;       /* type of node that owns the TG */
    unsigned char  dest[17];         /* TG destination node          */
    unsigned char  dest_type;        /* TG destination node type     */
    unsigned char  tg_num;           /* TG number                    */
    unsigned char  reserv3[1];       /* reserved                      */
    AP_UINT32      frsn;             /* flow reduction sequence number */
    AP_UINT16      days_left;        /* days left until entry purged */
    LINK_ADDRESS   dlc_data;         /* DLC signalling data          */
    AP_UINT32      rsn;              /* resource sequence number     */
    unsigned char  status;           /* tg status                    */
    TG_DEFINED_CHARS tg_chars;       /* TG characteristics           */
    unsigned char  subarea_number;   /* subarea number               */
    unsigned char  tg_type;          /* TG type                      */
    unsigned char  intersubnet_tg;   /* TG between subnets         */
    unsigned char  cp_cp_session_active; /* Are CP-CP sessions active? */
    unsigned char  branch_tg;       /* TG branch aware?            */
    unsigned char  multilink_tg;     /* reserved                     */
    unsigned char  appended_data_format; /* format of appended data     */
    unsigned char  appended_data_len; /* length of appended data     */
    unsigned char  reserva[9];       /* reserved                      */
} TOPOLOGY_TG_DETAIL;
```

```
typedef struct link_address
{
    unsigned char  format;           /* type of link address         */
    unsigned char  reserve1;         /* reserved                      */
    AP_UINT16      length;           /* length                       */
}
```

```

unsigned char  address[32];          /* address          */
} LINK_ADDRESS;

```

For details of the TG\_DEFINED\_CHARS structure, see [“DEFINE\\_LS” on page 100](#).

If the *frsn* field is set to a non-zero value then only node entries with that FRSN or greater will be returned. If it is set to zero then all node entries are returned.

If the *list\_options* parameter specifies detailed information, a TG Descriptor CV may be appended to the returned information. See the descriptions of the parameters *topology\_tg\_detail.appended\_data\_format* and *topology\_tg\_detail.appended\_data\_len* for more information.

## Supplied parameters

The application supplies the following parameters:

### **opcode**

AP\_QUERY\_NN\_TOPOLOGY\_TG

### **buf\_ptr**

A pointer to a data buffer that CS/AIX will use to return the requested information.

### **buf\_size**

Size of the supplied data buffer.

### **num\_entries**

Maximum number of TGs for which data should be returned. To request data for a specific TG rather than a range, specify the value 1. To return as many entries as possible, specify zero; in this case, CS/AIX will return the maximum number of entries that can be accommodated in the supplied data buffer.

### **list\_options**

The position in the list from which CS/AIX should begin to return data, and the level of information required for each entry. Specify the level of information with one of the following values:

#### **AP\_SUMMARY**

Summary information only.

#### **AP\_DETAIL**

Detailed information.

Combine this value using a logical OR operation with one of the following values:

#### **AP\_FIRST\_IN\_LIST**

Start at the first entry in the list.

#### **AP\_LIST\_INCLUSIVE**

Start at the entry specified by the combination of owner, destination, TG number, and FRSN.

#### **AP\_LIST\_FROM\_NEXT**

Start at the entry immediately following the entry specified by the combination of owner, destination, TG number, and FRSN.

The combination of the *owner*, *owner\_type*, *dest*, *dest\_type*, *tg\_num*, and *frsn* parameters specified is used as an index into the list of TGs if the *list\_options* parameter is set to AP\_LIST\_INCLUSIVE or AP\_LIST\_FROM\_NEXT.

The list is ordered by *owner*, *owner\_type* (in the order AP\_NETWORK\_NODE, AP\_VRN), *dest*, *dest\_type* (in the order AP\_NETWORK\_NODE, AP\_VRN), *tg\_num* (numerically), and lastly *frsn* (numerically). For more information about how the list is ordered and how the application can obtain specific entries from it, see [“List options for QUERY\\_\\* Verbs” on page 33](#).

### **owner**

Name of the node that owns the TG. This value is ignored if *list\_options* is set to AP\_FIRST\_IN\_LIST. The name is a 17-byte EBCDIC string, right-padded with EBCDIC spaces. It consists of a network ID of up to 8 A-string characters, an EBCDIC dot (period) character, and a network name of up to 8 A-string characters.

## QUERY\_NN\_TOPOLOGY\_TG

### ***owner\_type***

Type of the node that owns the TG. This parameter is ignored if *list\_options* is set to AP\_FIRST\_IN\_LIST. Possible values are:

#### **AP\_NETWORK\_NODE**

Network node.

#### **AP\_VRN**

Virtual routing node.

#### **AP\_LEARN\_NODE**

Node type is unknown.

### ***dest***

Name of the destination node for the TG. This value is ignored if *list\_options* is set to AP\_FIRST\_IN\_LIST. The name is a 17-byte EBCDIC string, right-padded with EBCDIC spaces. It consists of a network ID of up to 8 A-string characters, an EBCDIC dot (period) character, and a network name of up to 8 A-string characters.

### ***dest\_type***

Type of the destination node for the TG. This value is ignored if *list\_options* is set to AP\_FIRST\_IN\_LIST. Possible values are:

#### **AP\_NETWORK\_NODE**

Network node.

#### **AP\_VRN**

Virtual routing node.

#### **AP\_LEARN\_NODE**

Node type is unknown.

### ***tg\_num***

Number associated with the TG.

### ***frsn***

Flow Reduction Sequence Number (FRSN). Specify zero to return information about all TGs, or a nonzero value to return information about TGs with a FRSN greater than or equal to this value.

This parameter can be used to ensure that consistent information is obtained when the application needs to issue several verbs to obtain all the information. The application should take the following steps:

To Obtain Consistent Information Using the *frsn* Parameter

1. Issue QUERY\_NODE to get the node's current FRSN.
2. Issue as many QUERY\_NN\_TOPOLOGY\_TG verbs as necessary to get all the database entries, with the *frsn* parameter set to zero.
3. Issue QUERY\_NODE again and compare the new FRSN with the one returned in step 1.
4. If the two FRSNs are different, the database has changed. Add 1 to the FRSN obtained in step 1, and issue further QUERY\_NN\_TOPOLOGY\_TG verbs with the *frsn* parameter set to this new value. These verbs will return only the entries that have changed.

## Returned parameters: successful execution

If the verb executes successfully, CS/AIX returns the following parameters:

### ***primary\_rc***

AP\_OK

### ***buf\_size***

Length of the information returned in the supplied buffer.

***total\_buf\_size***

Returned value indicating the size of buffer that would have been required to return all the list information requested. A value greater than *buf\_size* indicates that not all the available entries were returned.

***num\_entries***

Number of entries returned in the data buffer.

***total\_num\_entries***

Total number of entries available. A value greater than *num\_entries* indicates that not all the available entries were returned.

Each entry in the data buffer consists of the following parameters:

***topology\_tg\_summary.overlay\_size***

The size of the returned *topology\_tg\_summary* structure, and therefore the offset to the start of the next entry in the data buffer.

When your application needs to go through the returned buffer to find each *topology\_tg\_summary* structure in turn, it must use this value to move to the correct offset for the next data structure, and must not use the C `sizeof()` operator. This is because the size of the returned overlay may increase in future releases of CS/AIX; using the returned overlay size ensures that your application will continue to work with future releases.

***topology\_tg\_summary.owner***

Name of the node that owns the TG. The name is a 17-byte EBCDIC string, padded on the right with EBCDIC spaces. It consists of a network ID of 1-8 A-string characters, an EBCDIC dot (period) character, and a network name of 1-8 A-string characters.

***topology\_tg\_summary.owner\_type***

Type of the node that owns the TG. Possible values are:

**AP\_NETWORK\_NODE**

Network node.

**AP\_END\_NODE**

End node.

**AP\_VRN**

Virtual routing node.

***topology\_tg\_summary.dest***

Name of the destination node for the TG. The name is a 17-byte EBCDIC string, padded on the right with EBCDIC spaces. It consists of a network ID of 1-8 A-string characters, an EBCDIC dot (period) character, and a network name of 1-8 A-string characters.

***topology\_tg\_summary.dest\_type***

Type of the destination node for the TG. Possible values are:

**AP\_NETWORK\_NODE**

Network node.

**AP\_END\_NODE**

End node.

**AP\_VRN**

Virtual routing node.

***topology\_tg\_summary.tg\_num***

Number associated with the TG.

***topology\_tg\_summary.frsn***

Flow Reduction Sequence Number (FRSN), indicating the last time that this resource was updated at the local node.

***topology\_tg\_detail.overlay\_size***

The size of the returned *topology\_tg\_detail* structure, and therefore the offset to the start of the next entry in the data buffer.

When your application needs to go through the returned buffer to find each `topology_tg_detail` structure in turn, it must use this value to move to the correct offset for the next data structure, and must not use the C `sizeof()` operator. This is because the size of the returned overlay may increase in future releases of CS/AIX; using the returned overlay size ensures that your application will continue to work with future releases.

***topology\_tg\_detail.owner***

Name of the node that owns the TG. The name is a 17-byte EBCDIC string, padded on the right with EBCDIC spaces. It consists of a network ID of 1-8 A-string characters, an EBCDIC dot (period) character, and a network name of 1-8 A-string characters.

***topology\_tg\_detail.owner\_type***

Type of the node that owns the TG. Possible values are:

**AP\_NETWORK\_NODE**

Network node.

**AP\_END\_NODE**

End node.

**AP\_VRN**

Virtual routing node.

***topology\_tg\_detail.dest***

Name of the destination node for the TG. The name is a 17-byte EBCDIC string, padded on the right with EBCDIC spaces. It consists of a network ID of 1-8 A-string characters, an EBCDIC dot (period) character, and a network name of 1-8 A-string characters.

***topology\_tg\_detail.dest\_type***

Type of the destination node for the TG. Possible values are:

**AP\_NETWORK\_NODE**

Network node.

**AP\_END\_NODE**

End node.

**AP\_VRN**

Virtual routing node.

***topology\_tg\_detail.tg\_num***

Number associated with the TG.

***topology\_tg\_detail.frsn***

Flow Reduction Sequence Number (FRSN), indicating the last time that this resource was updated at the local node.

***topology\_tg\_detail.days\_left***

Number of days before this TG entry will be deleted from the Topology Database.

***topology\_tg\_detail.dlc\_data.length***

If *dest\_type* or *owner\_type* is AP\_VRN, this field specifies the length of the DLC address in the following field. Otherwise, this field is not used.

***topology\_tg\_detail.dlc\_data.address***

If *dest\_type* or *owner\_type* is AP\_VRN, this field specifies the DLC address (in hexadecimal) of the connection to the VRN. The number of bytes in the address is given by the preceding field, *length*; the remaining bytes in the field are undefined. Otherwise, this field is not used.

For Token Ring or Ethernet, the address is in two parts: a 6-byte MAC address and a 1-byte local SAP address. The bit ordering of the MAC address may not be in the expected format; for information about converting between the two address formats, see [“Bit ordering in MAC addresses” on page 125](#).

For Enterprise Extender (HPR/IP), see [“QUERY\\_LS” on page 375](#) for details of the address format.

***topology\_tg\_detail.rsn***

Resource Sequence Number. This is assigned by the network node that owns this resource.

***topology\_tg\_detail.status***

Specifies the status of the TG. This may be one or more of the following, combined using a logical OR operation.

AP\_NONE

AP\_TG\_OPERATIVE

AP\_TG\_QUIESCING

AP\_TG\_CP\_CP\_SESSIONS

AP\_HPR

AP\_RTP

***topology\_tg\_detail.tg\_chars***

TG characteristics. For details of these parameters, see [“DEFINE\\_LS”](#) on page 100.

***topology\_tg\_detail.subarea\_number***

If the owner of the destination of the TG is subarea capable, this parameter contains the subarea number of the type-4 or type-5 node that owns the link station associated with the TG on the subarea capable node. Otherwise, this parameter is set to all binary zeros.

***topology\_tg\_detail.tg\_type***

Type of the TG. Possible values are:

**AP\_APPN\_OR\_BOUNDARY\_TG**

APPN TG or boundary function based TG.

**AP\_INTERCHANGE\_TG**

Interchange TG.

**AP\_VIRTUAL\_ROUTE\_BASED\_TG**

Virtual route based TG.

**AP\_UNKNOWN**

The TG type is unknown.

***topology\_tg\_detail.intersubnet\_tg***

Specifies whether the TG is an intersubnetwork TG. Possible values are:

**AP\_YES**

The TG is an intersubnetwork TG.

**AP\_NO**

The TG is not an intersubnetwork TG.

***topology\_tg\_detail.cp\_cp\_session\_active***

Specifies whether the owning node's contention winner CP-CP session is active. Possible values are:

**AP\_YES**

The CP-CP session is active.

**AP\_NO**

The CP-CP session is not active.

**AP\_UNKNOWN**

The CP-CP session status is unknown.

***topology\_tg\_detail.branch\_tg***

Specifies whether the TG is a branch TG. Possible values are:

**AP\_YES**

The TG is a branch TG.

**AP\_NO**

The TG is not a branch TG.

**AP\_UNKNOWN**

The TG type is unknown.

## QUERY\_NODE

### ***topology\_tg\_detail.appended\_data\_format***

Specifies the format of data appended to this NOF VCB structure.

If the parameter *topology\_tg\_detail.appended\_data\_len* is set to a non-zero value, indicating that appended data is included, this parameter is set to the following value:

### **AP\_TG\_DESCRIPTOR\_CV**

The appended data contains a TG Descriptor CV, as defined by SNA Formats.

If *topology\_tg\_detail.appended\_data\_len* is zero, indicating that no appended data is included, this parameter is reserved.

### ***topology\_tg\_detail.appended\_data\_len***

Specifies the length of the TG Descriptor CV data appended to this NOF VCB structure. If this parameter is set to zero, no appended data is included.

## Returned parameters: parameter check

If the verb does not execute because of a parameter error, CS/AIX returns the following parameters:

### ***primary\_rc***

AP\_PARAMETER\_CHECK

### ***secondary\_rc***

Possible values are:

#### **AP\_INVALID\_TG**

The *list\_options* parameter was set to AP\_LIST\_INCLUSIVE to list all entries starting from the supplied name, but the *tg\_num* parameter was not valid.

#### **AP\_INVALID\_ORIGIN\_NODE**

The *list\_options* parameter was set to AP\_LIST\_INCLUSIVE to list all entries starting from the supplied name, but the *owner* parameter was not valid.

#### **AP\_INVALID\_LIST\_OPTION**

The *list\_options* parameter was not set to a valid value.

Appendix B, “Common return codes,” on page 661 lists further secondary return codes associated with AP\_PARAMETER\_CHECK, which are common to all NOF verbs.

## Returned parameters: function not supported

If the verb does not execute successfully because the local node is not a network node, CS/AIX returns the following parameters:

### ***primary\_rc***

#### **AP\_FUNCTION\_NOT\_SUPPORTED**

The local node is not a network node. This verb can be used only at a network node.

## Returned parameters: other conditions

Appendix B, “Common return codes,” on page 661 lists further combinations of primary and secondary return codes that are common to all NOF verbs.

## QUERY\_NODE

QUERY\_NODE returns information about the definition of a CS/AIX node, and on its status if it is active.

## VCB structure

```
typedef struct query_node
{
    AP_UINT16      opcode;          /* verb operation code      */
    unsigned char  reserv2;        /* reserved                  */
}
```



```

unsigned char    format;                /* reserved */
AP_UINT16      primary_rc;             /* primary return code */
AP_UINT32      secondary_rc;          /* secondary return code */
CP_CREATE_PARMS cp_create_parms;      /* create parameters */
AP_UINT32      up_time;                /* time since node started */
AP_UINT32      mem_size;               /* reserved */
AP_UINT32      mem_used;               /* reserved */
AP_UINT32      mem_warning_threshold; /* reserved */
AP_UINT32      mem_critical_threshold; /* reserved */
unsigned char   nn_functions_supported; /* NN functions supported */
unsigned char   functions_supported;   /* functions supported */
unsigned char   en_functions_supported; /* EN functions supported */
unsigned char   nn_status;              /* node status */
AP_UINT32      nn_frsn;                 /* NN flow reduction sequence
                                        /* number */
AP_UINT32      nn_rsn;                  /* Resource sequence number */
AP_UINT16      def_ls_good_xids;        /* Good XIDS for defined link
                                        /* stations */
AP_UINT16      def_ls_bad_xids;         /* Bad XIDS for defined link
                                        /* stations */
AP_UINT16      dyn_ls_good_xids;        /* Good XIDS for dynamic link
                                        /* stations */
AP_UINT16      dyn_ls_bad_xids;         /* Bad XIDS for dynamic link
                                        /* stations */
unsigned char   dlur_release_level;     /* Current DLUR release level */
unsigned char   nns_dlus_served_lu_reg_supp; /* NNS supports DLUS-served
                                        /* LU registration? */
unsigned char   nns_en_reg_diff_owning_cp; /* NNS supports option 1123? */
unsigned char   reserva[17];            /* reserved */
unsigned char   fq_nn_server_name[17];  /* fully qualified NN server
                                        /* name */
AP_UINT32      current_isr_sessions;    /* number of ISR sessions */
unsigned char   nn_functions2;          /* further NN fns supported */
unsigned char   branch_ntwk_arch_version; /* level of BrNN support */
unsigned char   reservb[28];            /* reserved */
} QUERY_NODE;

```

```

typedef struct cp_create_parms
{
AP_UINT16      crt_parms_len;           /* length of CP_CREATE_PARMS */
unsigned char   description[32];        /* resource description */
unsigned char   reserv1[2];             /* reserved */
unsigned char   ms_support;             /* reserved */
unsigned char   queue_nmvt;            /* reserved */
unsigned char   reserv3[12];            /* reserved */
unsigned char   node_type;              /* node type */
unsigned char   fqcp_name[17];          /* fully qualified CP name */
unsigned char   cp_alias[8];            /* CP alias */
unsigned char   mode_to_cos_map_supp;   /* mode to COS mapping support */
unsigned char   mds_supported;          /* MDS and MS capabilities */
unsigned char   node_id[4];             /* node ID */
AP_UINT16      max_locates;             /* maximum locates node can process */
AP_UINT16      dir_cache_size;          /* directory cache size */
AP_UINT16      max_dir_entries;         /* maximum directory entries
                                        /* (0 means unlimited) */
AP_UINT16      locate_timeout;          /* locate timeout in seconds */
unsigned char   reg_with_nn;            /* register resources with NNs */
unsigned char   reg_with_cds;           /* register resources with CDS */
AP_UINT16      mds_send_alert_q_size;   /* size of MDS send alert queue */
AP_UINT16      cos_cache_size;          /* number of cos definitions */
AP_UINT16      tree_cache_size;         /* Topology Database routing tree
                                        /* cache size */
AP_UINT16      tree_cache_use_limit;     /* number of times a tree can be
                                        /* used */
AP_UINT16      max_tdm_nodes;           /* max number of nodes that can be
                                        /* stored in Topology Database */
AP_UINT16      max_tdm_tgs;            /* max number of TGs that can be
                                        /* stored in Topology Database */
AP_UINT32      max_isr_sessions;        /* maximum ISR sessions */
AP_UINT32      isr_sessions_upper_threshold; /* upper threshold for ISR
                                        /* sessions */
AP_UINT32      isr_sessions_lower_threshold; /* lower threshold for ISR
                                        /* sessions */
AP_UINT16      isr_max_ru_size;         /* max RU size for ISR */
AP_UINT16      isr_rcv_pac_window;      /* ISR receive pacing window size */
unsigned char   store_endpt_rscvs;      /* endpoint RSCV storage */
unsigned char   store_isr_rscvs;        /* ISR RSCV storage */
unsigned char   store_dlur_rscvs;       /* DLUR RSCV storage */
unsigned char   dlur_support;           /* is DLUR supported? */
unsigned char   pu_conc_support;        /* is PU conc supported? */
unsigned char   nn_rar;                 /* route additional resistance */
}

```

## QUERY\_NODE

```
unsigned char hpr_support;          /* level of HPR support      */
unsigned char mobile;              /* reserved                  */
unsigned char discovery_support;   /* reserved                  */
unsigned char discovery_group_name[8]; /* reserved                  */
unsigned char implicit_lu_0_to_3;  /* reserved                  */
unsigned char default_preference;  /* reserved                  */
unsigned char anynet_supported;    /* reserved                  */
AP_UINT16 max_ls_exception_events; /* max # exception entries  */
unsigned char reserv2[1];          /* reserved                  */
unsigned char max_compress_lvl;    /* Max compressson level (reserved)*/
unsigned char node_spec_data_len;  /* reserved                  */
unsigned char ptf[64];             /* program temporary fix array */
unsigned char cos_table_version;   /* version of COS tables to use */
unsigned char send_term_self;      /* default PLU-SLU session term */
unsigned char disable_branch_awareness; /* disable BrNN awareness */
unsigned char cplu_syncpt_support; /* syncpoint support on CP LU? */
unsigned char cplu_attributes;    /* attributes for CP LU      */
unsigned char reserved[95];        /* reserved                  */
} CP_CREATE_PARMS;
```

## Supplied parameters

The application supplies the following parameter:

### *opcode*

AP\_QUERY\_NODE

## Returned parameters: successful execution

If the verb executes successfully, CS/AIX returns the following parameters:

### *primary\_rc*

AP\_OK

### *cp\_create\_parms.crt\_parms\_len*

Length of create parameters structure.

### *cp\_create\_parms.description*

A null-terminated text string describing the node, as specified in the definition of the node.

### *cp\_create\_parms.node\_type*

Type of node. Possible values are:

AP\_NETWORK\_NODE

AP\_BRANCH\_NETWORK\_NODE

AP\_END\_NODE

AP\_LEN\_NODE

### *cp\_create\_parms.fqcp\_name*

Fully qualified name of the node. This is a 17-byte EBCDIC string, padded on the right with EBCDIC spaces. It consists of a network ID of 1-8 A-string characters, an EBCDIC dot (period) character, and a network name of 1-8 A-string characters.

### *cp\_create\_parms.cp\_alias*

Locally used CP alias. This is an 8-byte ASCII string. All 8 bytes are significant.

### *cp\_create\_parms.mode\_to\_cos\_map\_supp*

Specifies whether mode-to-COS mapping is supported by the node. This parameter is ignored for a network node; mode-to-COS mapping is always supported. For a LEN node, mode-to-COS mapping is not supported. Possible values are:

#### **AP\_YES**

Mode-to-COS mapping is supported.

#### **AP\_NO**

Mode-to-COS mapping is not supported.

***cp\_create\_parms.mds\_supported***

Specifies whether Management Services supports Multiple Domain Support and MS Capabilities.  
Possible values are:

**AP\_YES**

MDS is supported.

**AP\_NO**

MDS is not supported.

***cp\_create\_parms.node\_id***

Node identifier used in XID exchange. This is a 4-byte hexadecimal string.

***cp\_create\_parms.max\_locates***

Maximum number of locates that the node can process.

***cp\_create\_parms.dir\_cache\_size***

Network node only: Size of the directory cache.

***cp\_create\_parms.max\_dir\_entries***

Maximum number of directory entries. Zero indicates no limit.

***cp\_create\_parms.locate\_timeout***

Specifies the time in seconds before a network search will time out. Zero indicates no timeout.

***cp\_create\_parms.reg\_with\_nn***

End node only: Specifies whether to register the node's resources with the network node server when the node is started. Possible values are:

**AP\_YES**

Register resources with the NN. The end node's network node server will only forward directed locates to it.

**AP\_NO**

Do not register resources. The network node server will forward all broadcast searches to the end node.

***cp\_create\_parms.reg\_with\_cds***

End node: Specifies whether the network node server is allowed to register end node resources with a Central Directory server. This field is ignored if *reg\_with\_nn* is set to AP\_NO.

Network node: Specifies whether local or domain resources can be optionally registered with Central Directory server (AP\_YES or AP\_NO).

Possible values are:

**AP\_YES**

Register resources with the CDS.

**AP\_NO**

Do not register resources.

***cp\_create\_parms.mds\_send\_alert\_q\_size***

Size of the MDS send alert queue. If the number of queued alerts reaches this limit, CS/AIX deletes the oldest alert on the queue.

***cp\_create\_parms.cos\_cache\_size***

Network node: Size of the COS Database weights cache (the maximum number of COS definitions required). For an end node or LEN node, this parameter is reserved.

***cp\_create\_parms.tree\_cache\_size***

Network node: Size of the Topology Database routing tree cache. The minimum is 8. For an end node or LEN node, this parameter is reserved.

***cp\_create\_parms.tree\_cache\_use\_limit***

Network node: Maximum number of uses of a cached tree. When this number is exceeded, the tree is discarded and recomputed. This enables the node to balance sessions among equal weight routes. A low value provides better load balancing at the expense of increased activation latency. The minimum number of uses is 1. For an end node or LEN node, this parameter is reserved.

***cp\_create\_parms.max\_tdm\_nodes***

Network node: Maximum number of nodes that can be stored in Topology Database. A value of 0 (zero) indicates an unlimited number of nodes. For an end node or LEN node, this parameter is reserved.

***cp\_create\_parms.max\_tdm\_tgs***

Network node: Maximum number of TGs that can be stored in Topology Database. A value of 0 (zero) indicates an unlimited number of nodes. For an end node or LEN node, this parameter is reserved.

***cp\_create\_parms.max\_isr\_sessions***

Network node: Maximum number of ISR sessions the node can participate in at once. CS/AIX uses the value 100 unless a larger number has been specified. For an end node or LEN node, this parameter is reserved.

***cp\_create\_parms.isr\_sessions\_upper\_threshold* and *cp\_create\_parms.isr\_sessions\_lower\_threshold***

Network node: These thresholds control the node's congestion status, which is reported to other nodes in the network for use in route calculations. The node state changes from uncongested to congested if the number of ISR sessions exceeds the upper threshold. The node state changes back to uncongested when the number of ISR sessions dips below the lower threshold. For an end node or LEN node, these parameters are reserved.

***cp\_create\_parms.isr\_max\_ru\_size***

Network node or BrNN: Maximum RU size supported for intermediate or DLUR LU-LU sessions.

End node: Maximum RU size supported for DLUR LU-LU sessions.

For a LEN node, this parameter is reserved.

***cp\_create\_parms.isr\_rcv\_pac\_window***

Network node: Suggested receive pacing window size for intermediate sessions, in the range 1-63.

This value is only used on the secondary hop of intermediate sessions if the adjacent node does not support adaptive pacing. For an end node or LEN node, this parameter is reserved.

***cp\_create\_parms.store\_endpt\_rscvs***

Specifies whether RSCVs should be stored for diagnostic purposes. Possible values are:

**AP\_YES**

Store RSCVs.

**AP\_NO**

Do not store RSCVs.

If this field is set to AP\_YES, then an RSCV will be returned on the QUERY\_SESSION verb. (Setting this value to AP\_YES means an RSCV will be stored for each endpoint session. This extra storage can be up to 256 bytes per session.)

***cp\_create\_parms.store\_isr\_rscvs***

Network node: Specifies whether RSCVs should be stored for diagnostic purposes (AP\_YES or AP\_NO).

If this field is set to AP\_YES, then an RSCV will be returned on the QUERY\_ISR\_SESSION verb.

(Setting this value to AP\_YES means an RSCV will be stored for each ISR session. This extra storage can be up to 256 bytes per session.) For an end node or LEN node, this parameter is reserved.

***cp\_create\_parms.store\_dlur\_rscvs***

Specifies whether RSCVs should be stored for diagnostic purposes (AP\_YES or AP\_NO). If this field is set to AP\_YES, then an RSCV will be returned on the QUERY\_DLUR\_LU verb. (Setting this value to AP\_YES means an RSCV will be stored for each PLU-SLU session. This extra storage can be up to 256 bytes per session.)

***cp\_create\_parms.dlur\_support***

Specifies whether DLUR is supported. For a LEN node, this parameter is reserved. Possible values are:

**AP\_YES**

DLUR is supported.

**AP\_LIMITED\_DLUR\_MULTI\_SUBNET | AP\_NO**

End Node or Branch Network Node: DLUR is supported, but will not be used to connect to a DLUR in another subnet.

This value is not supported for a Network Node.

**AP\_NO**

DLUR is not supported.

***cp\_create\_parms.pu\_conc\_support***

Specifies whether SNA gateway is supported (AP\_YES or AP\_NO).

***cp\_create\_parms.nn\_rar***

The network node's route additional resistance.

***cp\_create\_parms.hpr\_support***

Specifies the level of HPR (High Performance Routing) support provided by the node. Possible values are:

**AP\_NONE**

No support for HPR.

**AP\_BASE**

This node can perform automatic network routing (ANR) but cannot act as an RTP (Rapid Transport Protocol) end point for HPR sessions.

**AP\_RTP**

This node can perform automatic network routing (ANR) and can act as an RTP (Rapid Transport Protocol) end point for HPR sessions.

**AP\_CONTROL\_FLOWS**

This node can perform all HPR functions including control flows.

***cp\_create\_parms.max\_ls\_exception\_events***

The maximum number of LS exception events recorded by the node.

***cp\_create\_parms.ptf***

Array for configuring and controlling future program temporary fix (ptf) operation, as follows:

***cp\_create\_parms.ptf[0]***

REQDISCONT support and Mandatory Search Status support.

CS/AIX normally uses REQDISCONT to deactivate limited resource host links that are no longer required by session traffic. This byte can be used to suppress use of REQDISCONT, or to modify the settings used on REQDISCONT requests sent by CS/AIX. Possible values:

**AP\_NONE**

Use the normal REQDISCONT support.

**AP\_SUPPRESS\_REQDISCONT**

Do not use REQDISCONT.

**AP\_OVERRIDE\_REQDISCONT**

Use a modified version of REQDISCONT support. If REQDISCONT is specified, it must be combined with one or both of the following values, using a logical OR operation:

**AP\_REQDISCONT\_TYPE**

Use type "immediate" on REQDISCONT; if this value is not specified, CS/AIX uses type "normal".

**AP\_REQDISCONT\_RECONTACT**

Use type "immediate recontact" on REQDISCONT; if this value is not specified, CS/AIX uses type "no immediate recontact".

When CS/AIX is running as an End Node or as a Branch Network Node, it may choose whether or not to invite network searches from its Network Node Server (NNS). Requesting network searches slows broadcast search processing for the network as a whole, so is undesirable. However, if the local node cannot register all its resources (LUs) with its NNS, requesting searches is the only way to make these resources visible to the network.

Normally, CS/AIX determines whether all LUs can be registered, then intelligently requests network searches from its NNS. If this node makes LUs accessible to the network in an unusual manner (for

example, if it is acting as a gateway for other nodes), the value above is combined with the following value to override the standard operation:

**AP\_SET\_SEARCH\_STATUS**

Unconditionally request network searches from the NNS.

***cp\_create\_parms.ptf[1]***

ERP support. CS/AIX normally processes an ACTPU(ERP) as an ERP; this resets the PU-SSCP session, but does not implicitly deactivate the subservient LU-SSCP and PLU-SLU sessions. SNA implementations may legally process ACTPU(ERP) as if it were ACTPU(cold), implicitly deactivating the subservient LU-SSCP and PLU-SLU sessions. Possible values:

**AP\_NONE**

Use the normal processing.

**AP\_OVERRIDE\_ERP**

Process all ACTPU requests as ACTPU(cold).

***cp\_create\_parms.ptf[2]***

LU 6.2 session activation and deactivation. CS/AIX normally does not include the ENQUEUE parameter on the INIT\_SELF message when activating a dependent LU 6.2 session, and uses the BIS protocol prior to deactivating a limited resource LU 6.2 session. Possible values:

**AP\_NONE**

Use the normal processing.

**AP\_SUPPRESS\_BIS**

Do not use the BIS protocol. Limited resource LU 6.2 sessions are deactivated immediately using UNBIND(cleanup).

**AP\_LU62\_INIT\_SELF\_ENQUEUE**

Use the old format of the INIT\_SELF message, which includes the ENQUEUE parameter.

***cp\_create\_parms.ptf[3]***

APINGD support. CS/AIX normally includes a partner program for the APING connectivity tester. This byte allows you to disable the APING Daemon within the node, so that requests by an APING program arriving at the node will not be processed automatically. Possible values:

**AP\_NONE**

Include APINGD support within the node (the normal processing).

**AP\_EXTERNAL\_APINGD**

Disable APINGD within the node.

***cp\_create\_parms.ptf[4]***

LU 0-3 RU checks. This byte is used to provide workarounds for host systems that send non-standard SNA data; it should be set to AP\_NONE unless you have encountered the specific problem described below.

The value AP\_NONE indicates CS/AIX's normal checking on LU 0-3 RUs.

If specific checks on LU 0-3 RUs have been relaxed, the following value is returned:

**AP\_ALLOW\_BB\_RQE**

The SNA protocols state that BB !EB RUs on LU 0-3 PLU-SLU sessions must be RQD. Several hosts send RQE BB !EB CD - a protocol violation which CS/AIX always tolerates. If this value is set, CS/AIX will tolerate RQE BB !EB !CD EC RUs as well.

**AP\_SEND\_ACTLU\_POWER\_ON**

When an application is using an LU 0-3 LU (for example if RUI\_INIT has been received for the LU) and ACTLU is received, this option indicates that CS/AIX should respond with a +ve RSP ACTLU containing the power on subvector. Without this flag CS/AIX sends an ACTLU RSP without this subvector and a subsequent NOTIFY message indicating the power on condition.

***cp\_create\_parms.ptf[5]***

Security checking for received Attaches.

If a local invocable TP is defined not to require conversation security, or is not defined and therefore defaults to not requiring conversation security, the invoking TP need not send a user ID and password to access it. If the invoking TP supplies these parameters and they are included in the Attach message that CS/AIX receives, CS/AIX normally checks the parameters (and rejects the Attach if they are not valid) even though the invocable TP does not require conversation security. This parameter allows you to disable the checking. Possible values:

**AP\_NONE**

Always check security parameters if they are included on a received Attach, regardless of the security requirements of the invocable TP (the normal processing).

**AP\_LIMIT\_TP\_SECURITY**

Do not check security parameters on a received Attach if the invocable TP does not require it.

***cp\_create\_parms.ptf[6]***

RTP options for HPR.

The value AP\_NONE indicates CS/AIX's normal RTP processing.

For customized RTP operation, one of the following values is returned:

**AP\_NO\_PROGRESSIVE\_ARB**

If this value is set, CS/AIX will advertise support for the standard and responsive mode ARB algorithms but not for the progressive mode algorithm.

***cp\_create\_parms.ptf[7]***

DLUR unbind on DACTLU. CS/AIX does not normally end the PLU-SLU session when it receives a DACTLU from the host for a session using DLUR. This parameter allows you to force ending of the PLU-SLU session. Possible values:

**AP\_NONE**

Use the normal processing.

**AP\_DLUR\_UNBIND\_ON\_DACTLU**

When DACTLU is received on a session using DLUR, end the PLU-SLU session.

***cp\_create\_parms.ptf[8]***

Suppress PU name on REQACTPU. CS/AIX normally identifies the PU name in the REQACTPU message when activating DLUR PUs. Possible values:

**AP\_NONE**

Use the normal processing.

**AP\_SUPPRESS\_PU\_NAME\_ON\_REQACTPU**

Suppress PU name when activating DLUR PUs.

**AP\_RETRY\_CNOS\_ON\_BIND\_NEG\_RSP**

During APPC session activation, the CNOS session activation can fail due to transitory conditions on the partner system. Some conditions indicated by particular sense codes are always retried (with a timer). This flag indicates that CS/AIX will always retry failed CNOS session activations.

***cp\_create\_parms.ptf[9]***

RUI bracket race options, limited resource override options for connection networks, and TCP/IP Information Control Vector options.

If an RUI application is using bracket protocols, and the host sends a BB (Begin Bracket) after the RUI application has already sent one, CS/AIX normally rejects this with sense data of 0813 and does not pass it to the application. Possible values:

**AP\_NONE**

Use the normal processing.

**AP\_LUA\_PASSTHRU\_BB\_RACE**

Pass the BB through to the RUI application. The application should send a negative response with sense data of either 0813 or 0814.

A link in CS/AIX that uses a connection network is normally a limited resource. The following value overrides this default:

**AP\_CN\_OVERRIDE\_LIM\_RES**

Use the *implicit\_limited\_resource* parameter in the port associated with each connection network link to determine whether it is a limited resource.

CS/AIX normally includes the TCP/IP Information Control Vector (0x64) in a NOTIFY request to the host for a TN3270 or LUA session. This vector contains information that can be displayed on the host console or used by the host (for example in billing): the TCP/IP address and port number used by the client, and the IP name corresponding to the client address. For TN3270, the TN3270 server normally performs a Domain Name Server (DNS) lookup to determine the client IP name.

If the client address is an IPv6 address but the host is running a back-level version of VTAM that cannot interpret IPv6 addresses, the client address may be displayed incorrectly on the host console.

The following flags allow you to override this behavior.

**AP\_NO\_TCPIP\_VECTOR**

Do not include the TCP/IP Information Control Vector (0x64) in NOTIFY requests to the host for either TN3270 or LUA.

Use this value if the host is running an older version of VTAM that does not support this control vector.

**AP\_NO\_TCPIP\_NAME**

Do not perform the DNS lookup, and send the CV64 control vector with the client IP address but no IP name.

This value applies only to TN3270; no DNS lookup is required for LUA clients. Use this value if the DNS environment is slow, or if you know that the clients are not included in the DNS data (for example if they are DHCP clients without DDNS).

***cp\_create\_parms.ptf[10]***

Suppress Logical Unit of Work Identifiers (LUWIDs) in FMH-5 Attach messages. CS/AIX normally includes the LUWID in the FMH-5 Attach message that it sends to start an APPC conversation.

The following flag allows you to override this behavior.

**AP\_DONT\_SEND\_LUWIDS**

Do not include the LUWID in the FMH-5 Attach; specify the field length for this field as zero.

***cp\_create\_parms.ptf[11]***

LU management options. Possible values:

**AP\_NONE**

Use the normal processing.

**AP\_DLUR\_USE\_REX\_PACING**

When the BIND from an upstream LU requests adaptive pacing with an unlimited pacing window, CS/AIX normally indicates this by specifying a window size of 0 (zero). If the downstream LU does not support adaptive pacing, it may incorrectly interpret this zero value as "no pacing", so CS/AIX must specify a non-zero pacing window size instead. This option indicates that CS/AIX uses the REX stage pacing value from the ACTLU as the pacing window size specified to the downstream LU.

**AP\_CLI\_OVERWRITE\_SYS\_NAME**

This option indicates that CS/AIX maintains the association between an APPC application running on a client and the pooled LU that it uses, so that subsequent conversations started by the partner application can be routed to the correct client. When a client application accesses an LU in a pool, CS/AIX changes the *sys\_name* parameter on the LU to the hostname of the client computer where the application is running. For more information about managing clients, refer to the *IBM Communications Server for Data Center Deployment on AIX Administration Guide*.

**AP\_OVERWRITE\_INTERNAL\_PU\_PARMS**

Normally, once a DLUR PU is defined, there is no way to modify configuration parameters on that PU without first deleting it (and any associated LUs). This flag permits CS/AIX to accept a fresh definition of a DLUR PU using `snaadmin` providing also that the node is inactive. All non-defaulted parameters must be defined (this is not equivalent to a `snaadmin -c` command).



***cp\_create\_parms.cos\_table\_version***

Specifies the version of the COS tables used by the node. Possible values:

**AP\_VERSION\_0\_COS\_TABLES**

Use the COS tables originally defined in the APPN Architecture Reference.

**AP\_VERSION\_1\_COS\_TABLES**

Use the COS tables originally defined for HPR over ATM.

***cp\_create\_parms.send\_term\_self***

Specifies the default method for ending a PLU-SLU session to a host. The value you specify is used for all type 0-3 LUs on the node, unless you override it by specifying a different value in the LU definition. Possible values:

**AP\_YES**

Send a TERM\_SELF on receipt of a CLOSE\_PLU\_SLU\_SEC\_RQ.

**AP\_NO**

Send an UNBIND on receipt of a CLOSE\_PLU\_SLU\_SEC\_RQ.

***cp\_create\_parms.disable\_branch\_awareness***

This parameter applies only if *node\_type* is AP\_NETWORK\_NODE; it is reserved for other node types.

Specifies whether the local node supports branch awareness, APPN Option Set 1120. Possible values:

**AP\_YES**

The local node does not support branch awareness. TGs between this node and served Branch Network Nodes do not appear in the network topology, and the local node does not report itself as being branch aware.

**AP\_NO**

The local node supports branch awareness.

***cp\_create\_parms.cplu\_syncpt\_support***

Specifies whether the node's Control Point LU supports Syncpoint functions. This parameter is equivalent to the *syncpt\_support* parameter on DEFINE\_LOCAL\_LU, but applies only to the node's Control Point LU (which does not have an explicit LU definition).

Set this parameter to AP\_YES only if you have a Sync Point Manager (SPM) and Conversation Protected Resource Manager (C-PRM) in addition to the standard CS/AIX product. Possible values are:

**AP\_YES**

Syncpoint is supported.

**AP\_NO**

Syncpoint is not supported.

***cp\_create\_parms.cplu\_attributes***

Identifies additional information about the node's Control Point LU. This parameter is equivalent to the *lu\_attributes* parameter on DEFINE\_LOCAL\_LU, but applies only to the node's Control Point LU (which does not have an explicit LU definition).

Possible values are:

**AP\_NONE**

No additional information identified.

**AP\_DISABLE\_PWSUB**

Disable password substitution support for the control point LU. Password substitution means that passwords are encrypted before transmission between the local and remote LUs, rather than being sent as clear text. CS/AIX normally uses password substitution if the remote system supports it.

This value is provided as a work-around for communications with some remote systems that do not implement password substitution correctly. If you use this option, you should be aware that this involves sending and receiving passwords in clear text (which may represent a security risk). The option should not be set unless there are problems with the remote system's implementation of password substitution.

***up\_time***

Time (in hundredths of a second) since the node was started (or restarted). A value of zero indicates that the node is not running.

***nn\_functions\_supported***

Network node only: Specifies the network node functions supported. This may be one or more of the following, combined using a logical OR.

**AP\_RCV\_REG\_CHAR**

Node supports receiving registered characteristics.

**AP\_GATEWAY**

Node is a gateway node.

**AP\_CDS**

Node supports Central Directory server function.

**AP\_TREE\_CACHING**

Node supports route tree cache.

**AP\_TREE\_UPDATES**

Node supports incremental tree updates. If this is supported, tree caching must also be supported.

**AP\_ISR**

Node supports Intermediate Session Routing.

***functions\_supported***

Specifies the functions supported. This may be one or more of the following, combined using a logical OR.

AP\_NEGOTIABLE\_LS

AP\_SEGMENT\_REASSEMBLY

AP\_BIND\_REASSEMBLY

AP\_PARALLEL\_TGS

AP\_CALL\_IN

AP\_ADAPTIVE\_PACING

AP\_TOPOLOGY\_AWARENESS

***en\_functions\_supported***

End node only: Specifies the end node functions supported. This may be one or more of the following, combined using a logical OR.

**AP\_SEGMENT\_GENERATION**

Node supports segment generation.

**AP\_MODE\_TO\_COS\_MAP**

Node supports mode name to COS name mapping.

**AP\_LOCATE\_CDINIT**

Node supports generation of locates and cross-domain initiate GDS variables for locating remote LUs.

**AP\_REG\_WITH\_NN**

Node will register its LUs with the adjacent serving network node.

**AP\_REG\_CHARS\_WITH\_NN**

Node supports send register characteristics. If this function is supported, send registered names must also be supported.

***nn\_status***

Network node only: Specifies the status of the node. This parameter may be set to AP\_UNCONGESTED, to any one of the other values listed, or to two or more of the other values combined using a logical OR. Possible values are:

**AP\_UNCONGESTED**

The number of ISR sessions is below the *isr\_sessions\_upper\_threshold* value in the node's configuration.

**AP\_CONGESTED**

The number of ISR sessions exceeds the threshold value.

**AP\_IRR\_DEPLETED**

The number of ISR sessions has reached the maximum specified for the node.

**AP\_ERR\_DEPLETED**

The number of endpoint sessions has reached the maximum specified.

**AP QUIESCING**

A STOP\_NODE of type AP\_QUIESCE or AP\_QUIESCE\_ISR has been issued.

***nn\_frsn***

Network node only: The network node's current Flow Reduction Sequence Number (FRSN).

***nn\_rsn***

Network node only: Resource sequence number.

***def\_ls\_good\_xids***

Total number of successful XID exchanges that have occurred on all defined link stations since the node was last started.

***def\_ls\_bad\_xids***

Total number of unsuccessful XID exchanges that have occurred on all defined link stations since the node was last started.

***dyn\_ls\_good\_xids***

Total number of successful XID exchanges that have occurred on all dynamic link stations since the node was last started.

***dyn\_ls\_bad\_xids***

Total number of unsuccessful XID exchanges that have occurred on all dynamic link stations since the node was last started.

***dlur\_release\_level***

Release level of the DLUR architecture supported by the node. This is set to the value 1 (the only release level of DLUR currently defined); future versions may incorporate later release levels of the DLUR architecture, and so may return different values.

***nns\_dlus\_served\_lu\_reg\_supp***

This parameter applies only if the local node is an end node or a Branch Network Node; it is reserved otherwise.

Specifies whether the network node server supports DLUS-served LU registration. Possible values are:

**AP\_YES**

The network node server supports registration of DLUS-served LUs.

**AP\_NO**

The network node server does not support registration of DLUS-served LUs.

**AP\_UNKNOWN**

The node does not have a network node server.

***nns\_en\_reg\_diff\_owning\_cp***

This parameter applies only if the local node is a Branch Network Node; it is reserved otherwise.

Specifies whether the network node server supports option set 1123 - End Node Resource Registration With Different Owing CP Name NNS(BrNN) Support.

**AP\_YES**

The network node server supports option set 1123.

**AP\_NO**

The network node server does not support option set 1123.

## QUERY\_NODE\_ALL

### AP\_UNKNOWN

The node does not have a network node server.

### *fq\_nn\_server\_name*

End node only. Name of the network node server for the node.

### *current\_isr\_sessions*

This parameter applies only if the local node is a Network Node or a Branch Network Node; it is reserved otherwise.

Number of ISR sessions routed through this node.

### *nn\_functions\_2*

This parameter applies only if the local node is a Network Node; it is reserved otherwise.

Specifies whether the node supports branch awareness, APPN Option Set 1120.

### AP\_NONE

The network node server does not support option set 1120.

### AP\_BRANCH\_AWARENESS

The node supports option set 1120.

### *branch\_ntwk\_arch\_version*

This parameter applies only if the local node is a Network Node or a Branch Network Node; it is reserved otherwise.

Specifies the version of the Branch Network Architecture supported. This is set to 1, or 0 (zero) if the node does not support the Branch Network Architecture.

## Returned parameters: other conditions

Appendix B, “Common return codes,” on page 661 lists further combinations of primary and secondary return codes that are common to all NOF verbs.

## QUERY\_NODE\_ALL

QUERY\_NODE\_ALL returns information about nodes on the CS/AIX LAN. This verb returns only each node's name and configuration file role, and does not provide detailed information about the node's configuration. The application can use QUERY\_NODE for a particular node name to obtain detailed information about that node.

This verb must be issued with a null target handle.

## VCB structure

```
typedef struct query_node_all
{
    AP_UINT16      opcode;                /* verb operation code          */
    unsigned char  reserv2;               /* reserved                     */
    unsigned char  format;                /* reserved                     */
    AP_UINT16      primary_rc;            /* primary return code          */
    AP_UINT32      secondary_rc;          /* secondary return code        */
    unsigned char  *buf_ptr;              /* pointer to buffer            */
    AP_UINT32      buf_size;              /* buffer size                  */
    AP_UINT32      total_buf_size;        /* total buffer size required   */
    AP_UINT16      num_entries;           /* number of entries            */
    AP_UINT16      total_num_entries;     /* total number of entries      */
    unsigned char  list_options;          /* listing options              */
    unsigned char  reserv3;               /* reserved                     */
    unsigned char  node_name[128];        /* node name                    */
} QUERY_NODE_ALL;
```

```
typedef struct node_summary
{
    AP_UINT16      overlay_size;           /* size of returned entry       */
    unsigned char  node_name[128];        /* node name                    */
    unsigned char  config_role;           /* server's config file role    */
}
```

```

    unsigned char   reserv3[12];           /* reserved */
} NODE_SUMMARY;

```

## Supplied parameters

The application supplies the following parameters:

### ***opcode***

AP\_QUERY\_NODE\_ALL

### ***buf\_ptr***

A pointer to a data buffer that CS/AIX will use to return the requested information.

### ***buf\_size***

Size of the supplied data buffer.

### ***num\_entries***

Maximum number of nodes for which data should be returned. To request data for a specific node rather than a range, specify the value 1. To return as many entries as possible, specify zero; in this case, CS/AIX will return the maximum number of entries that can be accommodated in the supplied data buffer.

### ***list\_options***

The position in the list from which CS/AIX should begin to return data. Possible values are:

#### **AP\_FIRST\_IN\_LIST**

Start at the first entry in the list of nodes.

#### **AP\_LIST\_INCLUSIVE**

Start at the entry specified by the *node\_name* parameter.

#### **AP\_LIST\_FROM\_NEXT**

Start at the entry immediately following the entry specified by the *node\_name* parameter.

The list is not ordered by node name. However, the order remains the same for subsequent QUERY\_NODE\_ALL verbs, so the application can obtain a complete list in several sections by using multiple verbs in the normal way. For more information about how the application can obtain specific entries from the list, see [“List options for QUERY\\_\\* Verbs” on page 33](#).

### ***node\_name***

Name of the node to be used as an index into the list. This parameter is ignored if *list\_options* is set to AP\_FIRST\_IN\_LIST.

This is an ASCII string of 1-128 characters, padded on the right with spaces if the name is shorter than 128 characters.

If the computer name includes a . (period) character, CS/AIX assumes that it is a fully-qualified name; otherwise it performs a DNS lookup to determine the computer name.

## Returned parameters: successful execution

If the verb executes successfully, CS/AIX returns the following parameters:

### ***primary\_rc***

AP\_OK

### ***buf\_size***

Length of the information returned in the supplied buffer.

### ***total\_buf\_size***

Returned value indicating the size of buffer that would have been required to return all the list information requested. A value greater than *buf\_size* indicates that not all the available entries were returned.

### ***num\_entries***

Number of entries returned in the data buffer.

## QUERY\_NODE\_LIMITS

### ***total\_num\_entries***

Total number of entries available. A value greater than *num\_entries* indicates that not all the available entries were returned.

Each entry in the data buffer consists of the following parameters:

### ***node\_summary.overlay\_size***

The size of the returned *node\_summary* structure, and therefore the offset to the start of the next entry in the data buffer.

When your application needs to go through the returned buffer to find each *node\_summary* structure in turn, it must use this value to move to the correct offset for the next data structure, and must not use the C `sizeof()` operator. This is because the size of the returned overlay may increase in future releases of CS/AIX; using the returned overlay size ensures that your application will continue to work with future releases.

### ***node\_summary.node\_name***

The name of the CS/AIX node.

### ***node\_summary.config\_role***

The configuration file role of the server where the node is running. For more information about configuration file roles, refer to the *IBM Communications Server for Data Center Deployment on AIX Administration Guide*. Possible values are:

#### **AP\_ROLE\_CONTROLLERR**

The server holds the controlling configuration file.

#### **AP\_ROLE\_BACKUP**

The server holds a backup configuration file.

#### **AP\_ROLE\_NONE**

The server does not share its copy of the configuration file.

## Returned parameters: parameter check

If the verb does not execute because of a parameter error, CS/AIX returns the following parameters:

### ***primary\_rc***

AP\_PARAMETER\_CHECK

### ***secondary\_rc***

Possible values are:

#### **AP\_INVALID\_NODE\_NAME**

The *list\_options* parameter was set to AP\_LIST\_INCLUSIVE to list all entries starting from the supplied name, but the *node\_name* parameter was not valid.

#### **AP\_INVALID\_LIST\_OPTION**

The *list\_options* parameter was not set to a valid value.

Appendix B, “Common return codes,” on page 661 lists further secondary return codes associated with AP\_PARAMETER\_CHECK, which are common to all NOF verbs.

## Returned parameters: other conditions

Appendix B, “Common return codes,” on page 661 lists further combinations of primary and secondary return codes that are common to all NOF verbs.

## QUERY\_NODE\_LIMITS

---

QUERY\_NODE\_LIMITS returns information about the functions that your CS/AIX license allows you to use on a particular node, and about your usage of these functions. These are divided into the following categories:

- Node options, which specify the CS/AIX features that you can use

- Node resource usage, which specifies the current and peak usage of CS/AIX resources.

You can use the information returned by this verb to check whether your usage of CS/AIX resources is within the limits permitted by your license. For more information about licensing requirements, see *IBM Communications Server for Data Center Deployment on AIX Quick Beginnings*.

The information returned by this verb is also written to the usage log file at intervals. For more information about this file, see *IBM Communications Server for Data Center Deployment on AIX Diagnostics Guide*.

## VCB structure

```
typedef struct query_node_limits
{
    AP_UINT16          opcode;           /* verb operation code          */
    unsigned char     reserv2;          /* reserved                     */
    unsigned char     format;          /* reserved                     */
    AP_UINT16          primary_rc;      /* primary return code          */
    AP_UINT32          secondary_rc;    /* secondary return code        */
    NODE_RESOURCE_LIMITS max_limits;    /* reserved                     */
    NODE_RESOURCE_LIMITS curr_usage;    /* current usage of LUs/sessions/users*/
    NODE_OPTIONS       node_options;    /* permitted functions          */
    unsigned char     reserv4[4];      /* reserved                     */
    NODE_RESOURCE_LIMITS max_usage;     /* highest usage counts         */
} QUERY_NODE_LIMITS;
```

```
typedef struct node_resource_limits
{
    AP_INT32          lu62_tps;         /* APPC/CPI-C applications      */
    AP_INT32          lua_tps;         /* LUA applications             */
    AP_INT32          fmapi_tps;       /* reserved                    */
    AP_INT32          link_stations;   /* Active link stations         */
    AP_INT32          tn3270_connections; /* TN3270 server connections   */
    AP_INT32          tn_redirector_connections; /* TN redirector connections */
    AP_INT32          v4_sna_channels; /* reserved                    */
    AP_INT32          v4_gsna_channels; /* reserved                    */
    AP_INT32          data_sessions;   /* Active PLU-SLU sessions     */
    AP_INT32          reserv1[11];     /* Reserved                    */
} NODE_RESOURCE_LIMITS;
```

```
typedef struct node_options
{
    unsigned char     network_node;    /* is Network Node supported?  */
    unsigned char     end_node;       /* is End Node supported?      */
    unsigned char     len_node;       /* is LEN Node supported?      */
    unsigned char     dlur_support;   /* is DLUR supported?         */
    unsigned char     pu_conc_support; /* is PU Conc supported?      */
    unsigned char     tn_server_support; /* is TN Server supported?    */
    unsigned char     hpr_support;    /* level of HPR support        */
    unsigned char     back_level_client; /* reserved                   */
    unsigned char     reserv2;        /* reserved                    */
    unsigned char     ssl_support;    /* is SSL supported?          */
    unsigned char     branch_network_node; /* is BrNN supported?       */
    unsigned char     reserv1[21];    /* reserved                    */
} NODE_OPTIONS;
```

## Supplied parameters

The application supplies the following parameter:

### **opcode**

AP\_QUERY\_NODE\_LIMITS

## Returned parameters: successful execution

If the verb executes successfully, CS/AIX returns the following parameters:

### **primary\_rc**

AP\_OK

### **curr\_usage.lu62\_tps**

The number of APPC and CPI-C applications currently active on this node.

## QUERY\_NODE\_LIMITS

### ***curr\_usage.lua\_tps***

The number of LUA applications currently active on this node.

### ***curr\_usage.link\_stations***

The number of link stations currently active on this node.

### ***curr\_usage.tn3270\_connections***

The number of connections from TN3270 clients currently active on this node.

### ***curr\_usage.tn\_redirector\_connections***

The number of connections from TN Redirector clients currently active on this node.

### ***curr\_usage.data\_sessions***

The number of PLU-SLU sessions currently active on this node.

### ***max\_usage.lu62\_tps***

The maximum number of APPC and CPI-C applications that have been active on this node at any time since the AIX computer was restarted.

### ***max\_usage.lua\_tps***

The maximum number of LUA applications that have been active on this node at any time since the AIX computer was restarted.

### ***max\_usage.link\_stations***

The maximum number of link stations that have been active on this node at any time since the AIX computer was restarted.

### ***max\_usage.tn3270\_connections***

The maximum number of connections from TN3270 clients that have been active on this node at any time since the AIX computer was restarted.

### ***max\_usage.tn\_redirector\_connections***

The maximum number of connections from TN Redirector clients that have been active on this node at any time since the AIX computer was restarted.

### ***max\_usage.data\_sessions***

The maximum number of PLU-SLU sessions that have been active on this node at any time since the AIX computer was restarted.

### ***node\_options.network\_node***

Specifies whether your license allows you to define this node as a network node. Possible values are:

#### **AP\_YES**

Network node is supported.

#### **AP\_NO**

Network node is not supported.

### ***node\_options.end\_node***

Specifies whether your license allows you to define this node as an end node. Possible values are:

#### **AP\_YES**

End node is supported.

#### **AP\_NO**

End node is not supported.

### ***node\_options.len\_node***

Specifies whether your license allows you to define this node as a LEN node. Possible values are:

#### **AP\_YES**

LEN node is supported.

#### **AP\_NO**

LEN node is not supported.

### ***node\_options.dlur\_support***

This parameter is reserved.

Specifies whether your license allows you to use Dependent LU Requester (DLUR) on this node. Possible values are:



**AP\_YES**

DLUR is supported.

**AP\_NO**

DLUR is not supported.

***node\_options.pu\_conc\_support***

Specifies whether your license allows you to use SNA gateway on this node. Possible values are:

**AP\_YES**

SNA gateway is supported.

**AP\_NO**

SNA gateway is not supported.

***node\_options.tn\_server\_support***

Specifies whether your license allows you to use TN server on this node. Possible values are:

**AP\_YES**

TN server is supported.

**AP\_NO**

TN server is not supported.

***node\_options.hpr\_support***

Specifies whether your license allows you to use HPR (High Performance Routing) on this node. Possible values are:

**AP\_YES**

HPR is supported.

**AP\_NO**

HPR is not supported.

***node\_options.ssl\_support***

Specifies whether the Secure Sockets Layer software is installed on the node (for use with TN Server). Possible values are:

**AP\_YES**

The SSL software is installed.

**AP\_NO**

The SSL software is not installed.

***node\_options.branch\_network\_node***

Specifies whether your license allows you to define this node as a branch network node. Possible values are:

**AP\_YES**

Branch network node is supported.

**AP\_NO**

Branch network node is not supported.

## Returned parameters: other conditions

Appendix B, “Common return codes,” on [page 661](#) lists further combinations of primary and secondary return codes that are common to all NOF verbs.

## QUERY\_PARTNER\_LU

---

QUERY\_PARTNER\_LU returns information about partner LUs that a local LU is currently using, or has used. This verb returns information about usage of the partner LUs, not about their definition; use QUERY\_PARTNER\_LU\_DEFINITION to obtain the definition of the partner LUs.

This verb can be used to obtain either summary or detailed information, about a specific LU or about multiple LUs, depending on the options used.

## QUERY\_PARTNER\_LU

This verb must be issued to a running node.

## VCB structure

```
typedef struct query_partner_lu
{
    AP_UINT16      opcode;                /* verb operation code          */
    unsigned char  reserv2;               /* reserved                      */
    unsigned char  format;                /* reserved                      */
    AP_UINT16      primary_rc;            /* primary return code          */
    AP_UINT32      secondary_rc;          /* secondary return code        */
    unsigned char  *buf_ptr;              /* pointer to buffer            */
    AP_UINT32      buf_size;              /* buffer size                  */
    AP_UINT32      total_buf_size;        /* total buffer size required    */
    AP_UINT16      num_entries;           /* number of entries            */
    AP_UINT16      total_num_entries;     /* total number of entries      */
    unsigned char  list_options;          /* listing options              */
    unsigned char  reserv3;               /* reserved                      */
    unsigned char  lu_name[8];            /* LU name                      */
    unsigned char  lu_alias[8];           /* LU alias                     */
    unsigned char  plu_alias[8];          /* partner LU alias             */
    unsigned char  fqplu_name[17];        /* fully qualified partner LU name */
    unsigned char  active_sessions;       /* active sessions only filter   */
} QUERY_PARTNER_LU;
```

```
typedef struct plu_summary
{
    AP_UINT16      overlay_size;          /* size of returned entry       */
    unsigned char  plu_alias[8];          /* partner LU alias             */
    unsigned char  fqplu_name[17];        /* fully qualified partner LU name */
    unsigned char  reserv1;               /* reserved                      */
    unsigned char  description[32];        /* resource description         */
    unsigned char  reserv2[16];           /* reserved                      */
    AP_UINT16      act_sess_count;         /* currently active sessions count */
    unsigned char  partner_cp_name[17];    /* partner LU CP name           */
    unsigned char  partner_lu_located;     /* CP name resolved?           */
} PLU_SUMMARY;
```

```
typedef struct plu_detail
{
    AP_UINT16      overlay_size;          /* size of returned entry       */
    unsigned char  plu_alias[8];          /* partner LU alias             */
    unsigned char  fqplu_name[17];        /* fully qualified partner LU name */
    unsigned char  reserv1;               /* reserved                      */
    unsigned char  description[32];        /* resource description         */
    unsigned char  reserv2[16];           /* reserved                      */
    AP_UINT16      act_sess_count;         /* currently active sessions count */
    unsigned char  partner_cp_name[17];    /* partner LU CP name           */
    unsigned char  partner_lu_located;     /* CP name resolved?           */
    unsigned char  plu_un_name[8];        /* partner LU uninterpreted name */
    unsigned char  parallel_sess_supp;    /* parallel sessions supported? */
    unsigned char  conv_security;         /* conversation security        */
    AP_UINT16      max_mc_ll_send_size;    /* maximum send LL size for mapped */
    /* conversations */
    unsigned char  implicit;              /* implicit or explicit entry   */
    unsigned char  security_details;       /* session security details     */
    unsigned char  duplex_support;         /* full-duplex support          */
    unsigned char  preference;            /* reserved                      */
    unsigned char  reserva[16];           /* reserved                      */
} PLU_DETAIL;
```

## Supplied parameters

The application supplies the following parameters:

### **opcode**

AP\_QUERY\_PARTNER\_LU

### **buf\_ptr**

A pointer to a data buffer that CS/AIX will use to return the requested information.

### **buf\_size**

Size of the supplied data buffer.

**num\_entries**

Maximum number of LUs for which data should be returned. To request data for a specific LU rather than a range, specify the value 1. To return as many entries as possible, specify zero; in this case, CS/AIX will return the maximum number of entries that can be accommodated in the supplied data buffer.

**list\_options**

The position in the list from which CS/AIX should begin to return data, and the level of information required for each entry. Specify the level of information with one of the following values:

**AP\_SUMMARY**

Summary information only.

**AP\_DETAIL**

Detailed information.

Combine this value using a logical OR operation with one of the following values:

**AP\_FIRST\_IN\_LIST**

Start at the first entry in the list of partner LUs associated with the specified local LU.

**AP\_LIST\_INCLUSIVE**

Start at the entry specified by the combination of local and partner LU names.

**AP\_LIST\_FROM\_NEXT**

Start at the entry immediately following the entry specified by the combination of local and partner LU names.

**AP\_LIST\_BY\_ALIAS**

The list is returned in order of LU alias rather than LU name. This option is only valid if AP\_FIRST\_IN\_LIST is also specified. (For AP\_LIST\_FROM\_NEXT or AP\_LIST\_INCLUSIVE, the list is in order of LU alias or LU name, depending on which was specified as the index into the list.)

The combination of the local LU (*lu\_name* or *lu\_alias*) and partner LU (*plu\_alias* or *fqplu\_name*) specified is used as an index into the list of partner LUs if the *list\_options* parameter is set to AP\_LIST\_INCLUSIVE or AP\_LIST\_FROM\_NEXT.

The list is ordered by *fqplu\_name*. For more information about how the list is ordered and how the application can obtain specific entries from it, see [“List options for QUERY\\_\\* Verbs” on page 33](#).

**lu\_name**

LU name of the local LU. This is an 8-byte type-A EBCDIC string, padded on the right with spaces if the name is shorter than 8 characters. To indicate that the LU is identified by its LU alias instead of its LU name, set this parameter to 8 binary zeros and specify the LU alias in the following parameter.

**lu\_alias**

LU alias of the local LU. This parameter is used only if the *lu\_name* field is set to 8 binary zeros, and is ignored otherwise. The alias is an 8-byte ASCII string, padded on the right with spaces if the name is shorter than 8 bytes. To indicate the LU associated with the local CP (the default LU), set both *lu\_name* and *lu\_alias* to binary zeros.

**plu\_alias**

Partner LU alias. This is an 8-byte ASCII string, padded on the right with spaces if the name is shorter than 8 bytes. If *list\_options* is set to AP\_FIRST\_IN\_LIST, this parameter is ignored; otherwise you must specify either the LU alias or the fully qualified LU name for the partner LU. To indicate that the LU is identified by its fully qualified name instead of its alias, set this parameter to 8 binary zeros and specify the LU name in the following parameter.

**fqplu\_name**

17-byte fully qualified network name for the partner LU. If *list\_options* is set to AP\_FIRST\_IN\_LIST, this parameter is ignored; otherwise you must specify either the LU alias or the fully qualified LU name for the partner LU. This parameter is used only if the *plu\_alias* field is set to 8 binary zeros, and is ignored otherwise.

## QUERY\_PARTNER\_LU

The name is a 17-byte EBCDIC string, right-padded with EBCDIC spaces. It consists of a network ID of up to 8 A-string characters, an EBCDIC dot (period) character, and a network name of up to 8 A-string characters.

### ***active\_sessions***

Specifies whether to return information only on partner LUs for which sessions are active, or on all partner LUs. Possible values are:

#### **AP\_YES**

Return information only on partner LUs for which sessions are currently active.

#### **AP\_NO**

Return information about all partner LUs for which sessions are active or have been active.

## Returned parameters: successful execution

If the verb executes successfully, CS/AIX returns the following parameters:

### ***primary\_rc***

AP\_OK

### ***buf\_size***

Length of the information returned in the supplied buffer.

### ***total\_buf\_size***

Returned value indicating the size of buffer that would have been required to return all the list information requested. A value greater than *buf\_size* indicates that not all the available entries were returned.

### ***num\_entries***

Number of entries returned in the data buffer.

### ***total\_num\_entries***

Total number of entries available. A value greater than *num\_entries* indicates that not all the available entries were returned.

Each entry in the data buffer consists of the following parameters:

### ***plu\_summary.overlay\_size***

The size of the returned *plu\_summary* structure, and therefore the offset to the start of the next entry in the data buffer.

When your application needs to go through the returned buffer to find each *plu\_summary* structure in turn, it must use this value to move to the correct offset for the next data structure, and must not use the C `sizeof()` operator. This is because the size of the returned overlay may increase in future releases of CS/AIX; using the returned overlay size ensures that your application will continue to work with future releases.

### ***plu\_summary.plu\_alias***

Partner LU alias. This is an 8-byte ASCII string, padded on the right with spaces if the name is shorter than 8 bytes.

### ***plu\_summary.fqplu\_name***

17-byte fully qualified network name for the partner LU. The name is a 17-byte EBCDIC string, padded on the right with EBCDIC spaces. It consists of a network ID of 1-8 A-string characters, an EBCDIC dot (period) character, and a network name of 1-8 A-string characters.

### ***plu\_summary.description***

A null-terminated text string describing the partner LU, as specified in the definition of the partner LU.

### ***plu\_summary.act\_sess\_count***

Total number of active sessions between the local LU and the partner LU.

### ***plu\_summary.partner\_cp\_name***

17-byte fully qualified network name for the CP associated with the partner LU. This parameter is not used if *partner\_lu\_located* below is set to AP\_NO.

The name is a 17-byte EBCDIC string, padded on the right with EBCDIC spaces. It consists of a network ID of up to 8 A-string characters, an EBCDIC dot (period) character, and a network name of up to 8 A-string characters.

***plu\_summary.partner\_lu\_located***

Specifies whether the local node has located the CP where the partner LU is located. Possible values are:

**AP\_YES**

The partner LU has been located. The *partner\_cp\_name* parameter contains the CP name of the partner LU.

**AP\_NO**

The partner LU has not yet been located. The *partner\_cp\_name* parameter should not be checked.

***plu\_detail.overlay\_size***

The size of the returned *plu\_detail* structure, and therefore the offset to the start of the next entry in the data buffer.

When your application needs to go through the returned buffer to find each *plu\_detail* structure in turn, it must use this value to move to the correct offset for the next data structure, and must not use the C `sizeof()` operator. This is because the size of the returned overlay may increase in future releases of CS/AIX; using the returned overlay size ensures that your application will continue to work with future releases.

***plu\_detail.plu\_alias***

Partner LU alias. This is an 8-byte ASCII string, padded on the right with spaces if the name is shorter than 8 bytes.

***plu\_detail.fqplu\_name***

17-byte fully qualified network name for the partner LU. The name is a 17-byte EBCDIC string, padded on the right with EBCDIC spaces. It consists of a network ID of 1-8 A-string characters, an EBCDIC dot (period) character, and a network name of 1-8 A-string characters.

***plu\_detail.description***

A null-terminated text string describing the partner LU, as specified in the definition of the partner LU.

***plu\_detail.act\_sess\_count***

Total number of active sessions between the local LU and the partner LU.

***plu\_detail.partner\_cp\_name***

17-byte fully qualified network name for the CP associated with the partner LU. This parameter is not used if *partner\_lu\_located* below is set to AP\_NO.

The name is a 17-byte EBCDIC string, padded on the right with EBCDIC spaces. It consists of a network ID of up to 8 A-string characters, an EBCDIC dot (period) character, and a network name of up to 8 A-string characters.

***plu\_detail.partner\_lu\_located***

Specifies whether the local node has located the CP where the partner LU is located. Possible values are:

**AP\_YES**

The partner LU has been located. The *partner\_cp\_name* parameter contains the CP name of the partner LU.

**AP\_NO**

The partner LU has not yet been located. The *partner\_cp\_name* parameter should not be checked.

***plu\_detail.plu\_un\_name***

Uninterpreted name of the partner LU. This is an 8-byte type-A EBCDIC character string.

***plu\_detail.parallel\_sess\_supp***

Specifies whether parallel sessions are supported. Possible values are:

**AP\_YES**

Parallel sessions are supported.

### **AP\_NO**

Parallel sessions are not supported.

### ***plu\_detail.conv\_security***

Specifies whether conversation security information can be sent to this partner LU. Possible values are:

### **AP\_YES**

Conversation security information supplied by a local TP is sent to the partner LU.

### **AP\_NO**

Conversation security information supplied by a local TP is not sent to the partner LU.

### **AP\_UNKNOWN**

No sessions are active with the partner LU.

### ***plu\_detail.max\_mc\_ll\_send\_size***

Maximum logical record size, in bytes, that can be sent to the partner LU. This may be in the range 1-32,767, or zero to indicate no limit (in which case the maximum is 32,767). Data records that are larger than this are broken down into several LL records before being sent to the partner LU.

### ***plu\_detail.implicit***

Specifies whether the entry was created by an implicit or explicit definition. Possible values are:

### **AP\_YES**

The entry is an implicit entry.

### **AP\_NO**

The entry is an explicit entry.

### ***plu\_detail.security\_details***

Returns the conversation security support as negotiated on the BIND. Possible values are:

### **AP\_CONVERSATION\_LEVEL\_SECURITY**

Conversation security information will be accepted on requests to or from the partner LU to allocate a conversation. The specific types of conversation security support are described by the following values.

### **AP\_ALREADY\_VERIFIED**

Both the local and partner LU agree to accept Already Verified requests to allocate a conversation. An Already Verified request needs to carry only a user ID. It does not need to carry a password.

### **AP\_PERSISTENT\_VERIFICATION**

Persistent Verification is supported on the session between the local and partner LUs. Once the initial request (carrying a user ID and usually a password) for a conversation has been verified, subsequent requests for a conversation need to carry only the user ID.

### **AP\_PASSWORD\_SUBSTITUTION**

The local and partner LU support Password Substitution conversation security. When a request to allocate a conversation is issued, the request carries an encrypted form of the password. If Password Substitution is not supported, the password is carried in clear text (nonencrypted) format. If the session does not support Password Substitution, an Allocate or Send\_Conversation with security type set to AP\_PGM\_STRONG will fail.

### **AP\_UNKNOWN**

No sessions are active with the partner LU.

### ***plu\_detail.duplex\_support***

Returns the conversation duplex support as negotiated on the BIND. Possible values are:

### **AP\_HALF\_DUPLEX**

Only half-duplex conversations are supported.

### **AP\_FULL\_DUPLEX**

Both full-duplex and half-duplex sessions are supported. Expedited data is also supported.

### **AP\_UNKNOWN**

The conversation duplex support is not known because no sessions are active with the partner LU.

**preference**

This parameter is reserved.

**Returned parameters: parameter check**

If the verb does not execute because of a parameter error, CS/AIX returns the following parameters:

**primary\_rc**

AP\_PARAMETER\_CHECK

**secondary\_rc**

Possible values are:

**AP\_INVALID\_LU\_ALIAS**

The *list\_options* parameter was set to AP\_LIST\_INCLUSIVE to list all entries starting from the supplied name, but the *lu\_alias* parameter was not valid.

**AP\_INVALID\_LU\_NAME**

The *list\_options* parameter was set to AP\_LIST\_INCLUSIVE to list all entries starting from the supplied name, but the *lu\_name* parameter was not valid.

**AP\_INVALID\_PLU\_NAME**

The *list\_options* parameter was set to AP\_LIST\_INCLUSIVE to list all entries starting from the supplied name, but one of the following conditions applies:

- The *fqplu\_name* parameter does not match the name of any of this local LU's partners.
- No sessions have been active (since the node was last started) for the specified combination of local LU and partner LU.

**AP\_INVALID\_LIST\_OPTION**

The *list\_options* parameter was not set to a valid value.

Appendix B, “Common return codes,” on page 661 lists further secondary return codes associated with AP\_PARAMETER\_CHECK, which are common to all NOF verbs.

**Returned parameters: other conditions**

Appendix B, “Common return codes,” on page 661 lists further combinations of primary and secondary return codes that are common to all NOF verbs.

**QUERY\_PARTNER\_LU\_DEFINITION**

QUERY\_PARTNER\_LU\_DEFINITION returns information about partner LUs for a local LU. This verb returns information about the definition of the LUs, not about their current usage; use QUERY\_PARTNER\_LU to obtain the usage information.

This verb can be used to obtain either summary or detailed information, about a specific LU or about multiple LUs, depending on the options used.

**VCB structure**

```
typedef struct query_partner_lu_definition
{
    AP_UINT16      opcode;                /* verb operation code          */
    unsigned char  reserv2;               /* reserved                     */
    unsigned char  format;               /* reserved                     */
    AP_UINT16      primary_rc;           /* primary return code          */
    AP_UINT32      secondary_rc;         /* secondary return code        */
    unsigned char  *buf_ptr;             /* pointer to buffer            */
    AP_UINT32      buf_size;             /* buffer size                  */
    AP_UINT32      total_buf_size;       /* total buffer size required   */
    AP_UINT16      num_entries;          /* number of entries            */
    AP_UINT16      total_num_entries;    /* total number of entries      */
    unsigned char  list_options;         /* listing options              */
    unsigned char  reserv3;             /* reserved                     */
    unsigned char  plu_alias[8];        /* partner LU alias             */
}
```

## QUERY\_PARTNER\_LU\_DEFINITION

```
    unsigned char  fqplu_name[17];          /* fully qualified partner LU name */
} QUERY_PARTNER_LU_DEFINITION;
```

```
typedef struct partner_lu_def_summary
{
    AP_UINT16      overlay_size;           /* size of returned entry          */
    unsigned char  plu_alias[8];          /* partner LU alias                 */
    unsigned char  fqplu_name[17];        /* fully qualified partner LU name  */
    unsigned char  description[32];       /* resource description             */
    unsigned char  reserv1[16];           /* reserved                          */
} PARTNER_LU_DEF_SUMMARY;
```

```
typedef struct partner_lu_def_detail
{
    AP_UINT16      overlay_size;           /* size of returned entry          */
    unsigned char  plu_alias[8];          /* partner LU alias                 */
    unsigned char  fqplu_name[17];        /* fully qualified partner LU name  */
    unsigned char  reserv1;               /* reserved                          */
    PLU_CHARS      plu_chars;             /* partner LU characteristics       */
} PARTNER_LU_DEF_DETAIL;
```

```
typedef struct plu_chars
{
    unsigned char  fqplu_name[17];        /* fully qualified partner LU name  */
    unsigned char  plu_alias[8];          /* partner LU alias                 */
    unsigned char  description[32];       /* resource description             */
    unsigned char  reserv2[16];           /* reserved                          */
    unsigned char  plu_un_name[8];        /* partner LU uninterpreted name    */
    unsigned char  preference;            /* reserved                          */
    AP_UINT16      max_mc_ll_send_size;   /* maximum MC send LL size         */
    unsigned char  conv_security_ver;     /* already-verified security       */
    /* supported?                          */
    unsigned char  parallel_sess_supp;    /* parallel sessions supported?    */
    unsigned char  reserv3[8];           /* reserved                          */
} PLU_CHARS;
```

## Supplied parameters

The application supplies the following parameters:

### **opcode**

AP\_QUERY\_PARTNER\_LU\_DEFINITION

### **buf\_ptr**

A pointer to a data buffer that CS/AIX will use to return the requested information.

### **buf\_size**

Size of the supplied data buffer.

### **num\_entries**

Maximum number of LUs for which data should be returned. To request data for a specific LU rather than a range, specify the value 1. To return as many entries as possible, specify zero; in this case, CS/AIX will return the maximum number of entries that can be accommodated in the supplied data buffer.

### **list\_options**

The position in the list from which CS/AIX should begin to return data, and the level of information required for each entry. Specify the level of information with one of the following values:

#### **AP\_SUMMARY**

Summary information only.

#### **AP\_DETAIL**

Detailed information.

Combine this value using a logical OR operation with one of the following values:

#### **AP\_FIRST\_IN\_LIST**

Start at the first entry in the list.



**AP\_LIST\_INCLUSIVE**

Start at the entry specified by the *plu\_alias* or *fqplu\_name* parameter.

**AP\_LIST\_FROM\_NEXT**

Start at the entry immediately following the entry specified by the *plu\_alias* or *fqplu\_name* parameter.

If AP\_FIRST\_IN\_LIST is specified, you can also include the following option, using a logical OR operation:

**AP\_LIST\_BY\_ALIAS**

The list is returned in order of LU alias rather than LU name. This option is only valid if AP\_FIRST\_IN\_LIST is also specified. (For AP\_LIST\_FROM\_NEXT or AP\_LIST\_INCLUSIVE, the list is in order of LU alias or LU name, depending on which was specified as the index into the list.)

For more information about how the application can obtain specific entries from the list, see [“List options for QUERY\\_\\* Verbs”](#) on page 33.

***plu\_alias***

Partner LU alias. The name is an 8-byte ASCII string, padded on the right with spaces if the name is shorter than 8 bytes. If *list\_options* is set to AP\_FIRST\_IN\_LIST, this parameter is ignored; otherwise you must specify either the LU alias or the fully qualified LU name for the partner LU. To indicate that the partner LU is defined by its fully qualified name instead of its alias, set this parameter to 8 binary zeros and specify the name in the following parameter.

***fqplu\_name***

Fully qualified name of the partner LU for which information is required, or the name to be used as an index into the list of LUs. If *list\_options* is set to AP\_FIRST\_IN\_LIST, this parameter is ignored; otherwise you must specify either the LU alias or the fully qualified LU name for the partner LU. This parameter is used only if the *plu\_alias* parameter is set to zeros, and is ignored otherwise.

The name is a 17-byte EBCDIC string, right-padded with EBCDIC spaces. It consists of a network ID of up to 8 A-string characters, an EBCDIC dot (period) character, and a network name of up to 8 A-string characters.

**Returned parameters: successful execution**

If the verb executes successfully, CS/AIX returns the following parameters:

***primary\_rc***

AP\_OK

***buf\_size***

Length of the information returned in the supplied buffer.

***total\_buf\_size***

Returned value indicating the size of buffer that would have been required to return all the list information requested. A value greater than *buf\_size* indicates that not all the available entries were returned.

***num\_entries***

Number of entries returned in the data buffer.

***total\_num\_entries***

Total number of entries available. A value greater than *num\_entries* indicates that not all the available entries were returned.

Each entry in the data buffer consists of the following parameters:

***partner\_lu\_def\_summary.overlay\_size***

The size of the returned *partner\_lu\_def\_summary* structure, and therefore the offset to the start of the next entry in the data buffer.

When your application needs to go through the returned buffer to find each *partner\_lu\_def\_summary* structure in turn, it must use this value to move to the correct offset for the next data structure, and must not use the C `sizeof()` operator. This is because the size of the

returned overlay may increase in future releases of CS/AIX; using the returned overlay size ensures that your application will continue to work with future releases.

### ***partner\_lu\_def\_summary.plu\_alias***

Partner LU alias. This is an 8-byte ASCII string, padded on the right with spaces if the name is shorter than 8 bytes.

### ***partner\_lu\_def\_summary.fqplu\_name***

Fully qualified network name for the partner LU. This name is a 17-byte EBCDIC string, padded on the right with EBCDIC spaces. It consists of a network ID of 1-8 A-string characters, an EBCDIC dot (period) character, and a network name of 1-8 A-string characters.

### ***partner\_lu\_def\_summary.description***

A null-terminated text string describing the partner LU, as specified in the definition of the partner LU.

### ***partner\_lu\_def\_detail.overlay\_size***

The size of the returned `partner_lu_def_detail` structure, and therefore the offset to the start of the next entry in the data buffer.

When your application needs to go through the returned buffer to find each `partner_lu_def_detail` structure in turn, it must use this value to move to the correct offset for the next data structure, and must not use the C `sizeof()` operator. This is because the size of the returned overlay may increase in future releases of CS/AIX; using the returned overlay size ensures that your application will continue to work with future releases.

### ***partner\_lu\_def\_detail.plu\_alias***

Partner LU alias. This is an 8-byte ASCII string, padded on the right with spaces if the name is shorter than 8 bytes.

### ***partner\_lu\_def\_detail.fqplu\_name***

Fully qualified network name for the partner LU. This name is a 17-byte EBCDIC string, padded on the right with EBCDIC spaces. It consists of a network ID of 1-8 A-string characters, an EBCDIC dot (period) character, and a network name of 1-8 A-string characters.

### ***partner\_lu\_def\_detail.plu\_chars.fqplu\_name***

Fully qualified network name for the partner LU. This name is a 17-byte EBCDIC string, padded on the right with EBCDIC spaces. It consists of a network ID of 1-8 A-string characters, an EBCDIC dot (period) character, and a network name of 1-8 A-string characters.

### ***partner\_lu\_def\_detail.plu\_chars.plu\_alias***

Partner LU alias. This is an 8-byte ASCII string, padded on the right with spaces if the name is shorter than 8 bytes.

### ***partner\_lu\_def\_detail.plu\_chars.description***

A null-terminated text string describing the partner LU, as specified in the definition of the partner LU.

### ***partner\_lu\_def\_detail.plu\_chars.plu\_un\_name***

Uninterpreted name of the partner LU. This is an 8-byte type-A EBCDIC string, padded on the right with spaces if the name is shorter than 8 characters.

### ***partner\_lu\_def\_detail.plu\_chars.preference***

This parameter is reserved.

### ***partner\_lu\_def\_detail.plu\_chars.max\_mc\_ll\_send\_size***

Maximum logical record length, in bytes, that can be sent to the partner LU. This may be in the range 1-32,767, or zero to indicate no limit (in which case the maximum is 32,767). Data records that are larger than this are broken down into several LL records before being sent to the partner LU.

### ***partner\_lu\_def\_detail.plu\_chars.conv\_security\_ver***

Specifies whether the partner LU is authorized to validate user IDs on behalf of local LUs; that is, whether the partner LU may set the already-verified indicator in an Attach request. Possible values are:

#### **AP\_YES**

The partner LU is authorized to validate user IDs.

#### **AP\_NO**

The partner LU is authorized to validate user IDs.

***partner\_lu\_def\_detail.plu\_chars.parallel\_sess\_supp***

Specifies whether parallel sessions are supported. Possible values are:

**AP\_YES**

Parallel sessions are supported.

**AP\_NO**

Parallel sessions are not supported.

**Returned parameters: parameter check**

If the verb does not execute because of a parameter error, CS/AIX returns the following parameters:

***primary\_rc***

AP\_PARAMETER\_CHECK

***secondary\_rc***

Possible values are:

**AP\_INVALID\_PLU\_NAME**

The *list\_options* parameter was set to AP\_LIST\_INCLUSIVE to list all entries starting from the supplied name, but the *plu\_alias* or *fqplu\_name* parameter was not valid.

**AP\_INVALID\_LIST\_OPTION**

The *list\_options* parameter was not set to a valid value.

Appendix B, "Common return codes," on page 661 lists further secondary return codes associated with AP\_PARAMETER\_CHECK, which are common to all NOF verbs.

**Returned parameters: other conditions**

Appendix B, "Common return codes," on page 661 lists further combinations of primary and secondary return codes that are common to all NOF verbs.

**QUERY\_PORT**

QUERY\_PORT returns a list of information about a node's ports. This information is structured as "determined data" (data gathered dynamically during execution) and "defined data" (the data supplied by the application on DEFINE\_PORT).

This verb can be used to obtain either summary or detailed information, about a specific port or about multiple ports, depending on the options used.

**VCB structure**

```
typedef struct query_port
{
    AP_UINT16      opcode;                /* verb operation code          */
    unsigned char  reserv2;              /* reserved                     */
    unsigned char  format;              /* reserved                     */
    AP_UINT16      primary_rc;          /* primary return code          */
    AP_UINT32      secondary_rc;        /* secondary return code        */
    unsigned char  *buf_ptr;            /* pointer to buffer            */
    AP_UINT32      buf_size;            /* buffer size                  */
    AP_UINT32      total_buf_size;      /* total buffer size required   */
    AP_UINT16      num_entries;         /* number of entries            */
    AP_UINT16      total_num_entries;   /* total number of entries      */
    unsigned char  list_options;        /* listing options              */
    unsigned char  reserv3;            /* reserved                     */
    unsigned char  port_name[8];        /* port name                    */
    unsigned char  dlc_name[8];        /* DLC name filter              */
} QUERY_PORT;
```

```
typedef struct port_summary
{
    AP_UINT16      overlay_size;        /* size of returned entry       */
    unsigned char  port_name[8];        /* port name                    */
    unsigned char  description[32];     /* resource description         */
}
```

## QUERY\_PORT

```

unsigned char   reserv2[16];           /* reserved                */
unsigned char   port_state;           /* port state              */
unsigned char   reserv1[1];          /* reserved                */
unsigned char   dlc_name[8];         /* name of DLC             */
} PORT_SUMMARY;

```

```

typedef struct port_detail
{
    AP_UINT16    overlay_size;         /* size of returned entry  */
    unsigned char port_name[8];       /* port name               */
    unsigned char reserv1[2];        /* reserved                */
    PORT_DET_DATA det_data;          /* determined data        */
    PORT_DEF_DATA def_data;          /* defined data            */
} PORT_DETAIL;

```

```

typedef struct port_det_data
{
    unsigned char port_state;         /* port state              */
    unsigned char dlc_type;          /* DLC type                */
    unsigned char port_sim_rim;      /* port initialization options */
    unsigned char reserv1;          /* reserved                */
    AP_UINT16    def_ls_good_xids;    /* number of successful XIDs */
    AP_UINT16    def_ls_bad_xids;    /* number of unsuccessful XIDs */
    AP_UINT16    dyn_ls_good_xids;   /* successful XIDs on dynamic */
    AP_UINT16    dyn_ls_bad_xids;    /* LS count               */
    AP_UINT16    num_implicit_links; /* failed XIDs on dynamic LS */
    unsigned char neg_ls_supp;       /* negotiable?            */
    unsigned char abm_ls_supp;       /* ABM support?          */
    AP_UINT32    start_time;         /* Start time of the port  */
    unsigned char reserva[12];       /* reserved                */
} PORT_DET_DATA;

```

```

typedef struct port_def_data
{
    unsigned char description[32];    /* resource description    */
    unsigned char initially_active;  /* is the port initially active? */
    unsigned char reserv2[15];       /* reserved                */
    unsigned char dlc_name[8];       /* DLC name associated with port */
    unsigned char port_type;         /* port type              */
    unsigned char port_attributes[4]; /* port attributes        */
    unsigned char implicit_uplink_to_en; /* implicit EN links up or down? */
    unsigned char implicit_appn_links_len; /* reserved                */
    unsigned char reserv3;          /* reserved                */
    AP_UINT32    port_number;        /* port number            */
    AP_UINT16    max_rcv_btu_size;   /* max receive BTU size  */
    AP_UINT16    tot_link_act_lim;   /* total link activation limit */
    AP_UINT16    inb_link_act_lim;   /* inbound link activation limit */
    AP_UINT16    out_link_act_lim;   /* outbound link activation limit */
    unsigned char ls_role;          /* initial link station role */
    unsigned char retry_flags;       /* reserved                */
    AP_UINT16    max_activation_attempts; /* reserved                */
    AP_UINT16    activation_delay_timer; /* reserved                */
    unsigned char mltg_pacing_algorithm; /* reserved                */
    unsigned char implicit_tg_sharing_prohibited; /* reserved                */
    unsigned char link_spec_data_format; /* reserved                */
    unsigned char limit_enable;      /* reserved                */
    unsigned char reserv1[6];        /* reserved                */
    unsigned char implicit_dspu_template[8]; /* implicit dspu template */
    AP_UINT16    implicit_ls_limit;   /* implicit ls limit      */
    unsigned char reserv4;          /* reserved                */
    unsigned char implicit_dspu_services; /* reserved                */
    unsigned char implicit_deact_timer; /* deact timer for implicit LSs */
    AP_UINT16    act_xid_exchange_limit; /* activation XID exchange limit */
    AP_UINT16    nonact_xid_exchange_limit; /* non-act. XID exchange limit */
    unsigned char ls_xmit_rcv_cap;   /* LS transmit-receive capability */
    unsigned char max_ifrm_rcvd;     /* maximum number of I-frames that can be received */
    AP_UINT16    target_pacing_count; /* target pacing count    */
    AP_UINT16    max_send_btu_size;  /* maximum send BTU size  */
    LINK_ADDRESS dlc_data;           /* DLC data               */
    LINK_ADDRESS hpr_dlc_data;       /* reserved                */
    unsigned char implicit_cp_cp_sess_support; /* implicit links allow CP-CP sessions */
    unsigned char implicit_limited_resource; /* implicit links are limited resource */
    unsigned char implicit_hpr_support; /* Implicit links support HPR */
}

```

```

unsigned char  implicit_link_lvl_error; /* Send HPR traffic on implicit */
                                                    /* links using link-level error */
                                                    /* recovery? */
unsigned char  retired1; /* reserved */
TG_DEFINED_CHARS default_tg_chars; /* default TG chars */
unsigned char  discovery_supported; /* reserved */
AP_UINT16     port_spec_data_len; /* length of port specific data */
AP_UINT16     link_spec_data_len; /* length of link specific data */
} PORT_DEF_DATA;

```

For more details of the `link_address` structure, see “[QUERY\\_LS](#)” on page 375; for more details of the port-specific and link-specific data, see “[DEFINE\\_PORT](#)” on page 159 and “[DEFINE\\_LS](#)” on page 100. The data structure for the port-specific data follows the `port_def_data` structure, and the data structure for the link-specific data follows this; both structures are padded to start on a 4-byte boundary.

## Supplied parameters

The application supplies the following parameters:

### ***opcode***

AP\_QUERY\_PORT

### ***buf\_ptr***

A pointer to a data buffer that CS/AIX will use to return the requested information.

### ***buf\_size***

Size of the supplied data buffer.

### ***num\_entries***

Maximum number of ports for which data should be returned. To request data for a specific port rather than a range, specify the value 1. To return as many entries as possible, specify zero; in this case, CS/AIX will return the maximum number of entries that can be accommodated in the supplied data buffer.

### ***list\_options***

The position in the list from which CS/AIX should begin to return data, and the level of information required for each entry. Specify the level of information with one of the following values:

#### **AP\_SUMMARY**

Summary information only.

#### **AP\_DETAIL**

Detailed information.

Combine this value using a logical OR operation with one of the following values:

#### **AP\_FIRST\_IN\_LIST**

Start at the first entry in the list.

#### **AP\_LIST\_INCLUSIVE**

Start at the entry specified by the `port_name` parameter.

#### **AP\_LIST\_FROM\_NEXT**

Start at the entry immediately following the entry specified by the `port_name` parameter.

For more information about how the list is ordered and how the application can obtain specific entries from it, see “[List options for QUERY\\_\\* Verbs](#)” on page 33.

### ***port\_name***

Name of port being queried. This is an 8-byte ASCII string, padded on the right with spaces if the name is shorter than 8 bytes. This parameter is ignored if `list_options` is set to `AP_FIRST_IN_LIST`.

### ***dlc\_name***

DLC name filter. To return information only on ports associated with a specific DLC, specify the DLC name. This is an 8-byte ASCII string, padded on the right with spaces if the name is shorter than 8 bytes. To return information about all ports without filtering on the DLC name, set this parameter to 8 binary zeros.

## Returned parameters: successful execution

If the verb executes successfully, CS/AIX returns the following parameters:

***primary\_rc***

AP\_OK

***buf\_size***

Length of the information returned in the supplied buffer.

***total\_buf\_size***

Returned value indicating the size of buffer that would have been required to return all the list information requested. A value greater than *buf\_size* indicates that not all the available entries were returned.

***num\_entries***

Number of entries returned in the data buffer.

***total\_num\_entries***

Total number of entries available. A value greater than *num\_entries* indicates that not all the available entries were returned.

Each entry in the data buffer consists of the following parameters:

***port\_summary.overlay\_size***

The size of the returned *port\_summary* structure, and therefore the offset to the start of the next entry in the data buffer.

When your application needs to go through the returned buffer to find each *port\_summary* structure in turn, it must use this value to move to the correct offset for the next data structure, and must not use the C `sizeof()` operator. This is because the size of the returned overlay may increase in future releases of CS/AIX; using the returned overlay size ensures that your application will continue to work with future releases.

***port\_summary.port\_name***

Name of the port. This is an 8-byte ASCII string, padded on the right with spaces if the name is shorter than 8 bytes.

***port\_summary.description***

A null-terminated text string describing the port, as specified in the definition of the port.

***port\_summary.port\_state***

Specifies the current state of the port. Possible values are:

**AP\_ACTIVE**

The port is active.

**AP\_NOT\_ACTIVE**

The port is not active.

**AP\_PENDING\_ACTIVE**

START\_PORT is in progress.

**AP\_PENDING\_INACTIVE**

STOP\_PORT is in progress.

***port\_summary.dlc\_name***

Name of the DLC associated with this port. This is an 8-byte ASCII string, padded on the right with spaces if the name is shorter than 8 bytes.

***port\_detail.overlay\_size***

The size of the returned *port\_detail* structure, and therefore the offset to the start of the next entry in the data buffer.

When your application needs to go through the returned buffer to find each *port\_detail* structure in turn, it must use this value to move to the correct offset for the next data structure, and must not use the C `sizeof()` operator. This is because the size of the returned overlay may increase in future

releases of CS/AIX; using the returned overlay size ensures that your application will continue to work with future releases.

***port\_detail.port\_name***

Name of the port. This is an 8-byte ASCII string, padded on the right with spaces if the name is shorter than 8 bytes.

***port\_detail.det\_data.port\_state***

Specifies the current state of the port. Possible values are:

**AP\_ACTIVE**

The port is active.

**AP\_NOT\_ACTIVE**

The port is not active.

**AP\_PENDING\_ACTIVE**

START\_PORT is in progress.

**AP\_PENDING\_INACTIVE**

STOP\_PORT is in progress.

***port\_detail.det\_data.dlc\_type***

DLC type for the port. This is one of the following:

**AP\_SDLC**

SDLC

**AP\_X25**

QLLC

**AP\_TR**

Token Ring

**AP\_ETHERNET**

Ethernet

**AP\_IP**

Enterprise Extender (HPR/IP)

***port\_detail.det\_data.port\_sim\_rim***

Specifies whether Set Initialization Mode (SIM) and Receive Initialization Mode (RIM) are supported. Possible values are:

**AP\_YES**

SIM and RIM are supported.

**AP\_NO**

SIM and RIM are not supported.

***port\_detail.det\_data.def\_ls\_good\_xids***

Total number of successful XID exchanges that have occurred on all defined link stations on this port since the last time this port was started.

***port\_detail.det\_data.def\_ls\_bad\_xids***

Total number of unsuccessful XID exchanges that have occurred on all defined link stations on this port since the last time this port was started.

***port\_detail.det\_data.dyn\_ls\_good\_xids***

Total number of successful XID exchanges that have occurred on all dynamic link stations on this port since the last time this port was started.

***port\_detail.det\_data.dyn\_ls\_bad\_xids***

Total number of unsuccessful XID exchanges that have occurred on all dynamic link stations on this port since the last time this port was started.

***port\_detail.det\_data.num\_implicit\_links***

Total number of implicit links currently active on this port. This includes dynamic links and implicit links created following use of Discovery. The number of such links allowed on this port is limited by the *implicit\_ls\_limit* parameter of *port\_def\_data*.

***port\_detail.det\_data.neg\_ls\_supp***

Support for negotiable link stations. Possible values are:

**AP\_YES**

Link stations can be negotiated.

**AP\_NO**

Link stations cannot be negotiated.

***port\_detail.det\_data.abm\_ls\_supp***

Support for ABM link stations. Possible values are:

**AP\_YES**

ABM link stations are supported.

**AP\_NO**

ABM link stations are not supported.

**AP\_UNKNOWN**

Support for ABM link stations cannot be determined because the DLC associated with this port has not yet been started.

***port\_detail.det\_data.start\_time***

The elapsed time, in hundredths of a second, between the time the node was started and the last time this port was started. If this port has not yet been started, this parameter is set to zero.

***port\_detail.def\_data.description***

A null-terminated text string describing the port, as specified in the definition of the port.

***port\_detail.def\_data.dlc\_name***

Name of the DLC associated with this port. This is an 8-byte ASCII string, padded on the right with spaces if the name is shorter than 8 bytes.

***port\_detail.def\_data.port\_type***

The type of line used by the port.

For SDLC, the following values may be returned:

**AP\_PORT\_SWITCHED**

Switched line.

**AP\_PORT\_NONSWITCHED**

Nonswitched line.

For QLLC, this is set to AP\_PORT\_SWITCHED.

For Token Ring / Ethernet, this is set to AP\_PORT\_SATF (shared access transport facility).

For Enterprise Extender (HPR/IP), this is set to AP\_PORT\_SATF (shared access transport facility).

***port\_detail.def\_data.port\_attributes***

This is a bit field. It can take the value AP\_NO, or the following:

**AP\_RESOLVE\_BY\_LINK\_ADDRESS**

This value specifies that an attempt is made to resolve incoming calls by using the link address on CONNECT\_IN before using the CP name (or node ID) carried on the received XID3 to resolve them. This is ignored if the *port\_type* parameter is not set to AP\_PORT\_SWITCHED.

***def\_data.implicit\_uplink\_to\_en***

This parameter applies only if the local node is a Branch Network Node; it is reserved if the local node is any other type.

If the adjacent node is an end node, this parameter specifies whether implicit link stations off this port are uplink or downlink. This parameter is ignored if there are existing links to the same adjacent node, because in this case the existing links are used to determine the link type. Possible values are:

**AP\_YES**

Implicit links to an End Node are uplinks.



**AP\_NO**

Implicit links to an End Node are downlinks.

***port\_detail.def\_data.port\_number***

Port number.

***port\_detail.def\_data.max\_rcv\_btu\_size***

Maximum BTU size that can be received.

***port\_detail.def\_data.tot\_link\_act\_lim***

Total link activation limit.

***port\_detail.def\_data.inb\_link\_act\_lim***

Inbound link activation limit.

***port\_detail.def\_data.out\_link\_act\_lim***

Outbound link activation limit.

***port\_detail.def\_data.ls\_role***

Link station role.

For SDLC or QLLC, the following values may be returned:

**AP\_LS\_PRI**

Primary

**AP\_LS\_SEC**

Secondary

**AP\_LS\_NEG**

Negotiable

For Token Ring / Ethernet, this is set to AP\_LS\_NEG (negotiable).

***port\_detail.def\_data.implicit\_dspu\_template***

Specifies the DSPU template, defined with the DEFINE\_DSPU\_TEMPLATE verb, that will be used for definitions if the local node is to provide SNA gateway for an implicit link activated on this port. If the template specified does not exist (or is already at its instance limit) when the link is activated, activation will fail. This is an 8-byte string in a locally displayable character set. All eight bytes are significant and must be set.

If the *def\_data.implicit\_dspu\_services* parameter is not set to AP\_PU\_CONCENTRATION, this parameter is reserved.

***port\_detail.def\_data.implicit\_ls\_limit***

The maximum number of implicit link stations which can be active on this port simultaneously, including dynamic links and links activated for Discovery. A value of zero indicates that there is no limit; a value of AP\_NO\_IMPLICIT\_LINKS indicates that no implicit links are allowed.

***port\_detail.def\_data.implicit\_deact\_timer***

Limited resource link deactivation timer, in seconds.

If *implicit\_limited\_resource* is set to AP\_YES or AP\_NO\_SESSIONS, then an HPR-capable implicit link is automatically deactivated if no data flows on the link for the duration of this timer, and no sessions are using the link.

If *implicit\_limited\_resource* is set to AP\_INACTIVITY, then an implicit link is automatically deactivated if no data flows on the link for the duration of this timer.

***port\_detail.def\_data.act\_xid\_exchange\_limit***

Activation XID exchange limit.

***port\_detail.def\_data.nonact\_xid\_exchange\_limit***

Non-activation XID exchange limit.

***port\_detail.def\_data.ls\_xmit\_rcv\_cap***

Specifies the link station transmit/receive capability. Possible values are:

**AP\_LS\_TWS**

Two-way simultaneous

**AP\_LS\_TWA**

Two-way alternating

***port\_detail.def\_data.max\_ifrm\_rcvd***

Maximum number of I-frames that can be received by local link stations before an acknowledgment is sent. Range: 1-127.

***port\_detail.def\_data.target\_pacing\_count***

Numeric value between 1 and 32,767 inclusive indicating the desired pacing window size. (The current version of CS/AIX does not make use of this value.)

***port\_detail.def\_data.max\_send\_btu\_size***

Maximum BTU size that can be sent.

***port\_detail.def\_data.dlc\_data***

Port address. For more information on the `dlc_data` structure, see [“QUERY\\_LS” on page 375](#).

***def\_data.implicit\_cp\_cp\_sess\_support***

Specifies whether CP-CP sessions are permitted for implicit link stations using this port. Possible values are:

**AP\_YES**

CP-CP sessions are permitted for implicit LSs.

**AP\_NO**

CP-CP sessions are not permitted for implicit LSs.

***def\_data.implicit\_limited\_resource***

Specifies whether implicit link stations off this port are defined as limited resources. Possible values are:

**AP\_NO**

Implicit links are not limited resources, and will not be deactivated automatically.

**AP\_NO\_SESSIONS**

Implicit links are limited resources, and will be deactivated automatically when no active sessions are using them.

**AP\_INACTIVITY**

Implicit links are limited resources, and will be deactivated automatically when no active sessions are using them or when no data has flowed for the time period specified by the `implicit_deact_timer` field.

***def\_data.implicit\_hpr\_support***

Specifies whether High Performance Routing (HPR) is supported on implicit links. Possible values are:

**AP\_YES**

HPR is supported on implicit links.

**AP\_NO**

HPR is not supported on implicit links.

***def\_data.implicit\_link\_lvl\_error***

For SDLC, this parameter is not used.

For other link types, this parameter specifies whether HPR traffic should be sent on implicit links using link-level error recovery (AP\_YES or AP\_NO). The parameter is reserved if `implicit_hpr_support` is set to AP\_NO.

***def\_data.default\_tg\_chars***

Default TG characteristics. These are used for implicit link stations using this port, and as the default TG characteristics for defined link stations that do not have TG characteristics explicitly defined. For details of these parameters, see [“DEFINE\\_LS” on page 100](#).

***port\_detail.def\_data.port\_spec\_data\_len***

Unpadded length, in bytes, of the port-specific data. The data structure for this data follows the `port_def_data` structure, but is padded to start on a 4-byte boundary. For more details of the port-specific data, see [“DEFINE\\_PORT” on page 159](#).

***port\_detail.def\_data.link\_spec\_data\_len***

Unpadded length, in bytes, of the link-specific data. The data structure for the link-specific data follows the data structure for the port-specific data, but is padded to start on a 4-byte boundary. For more details of the link-specific data, see [“DEFINE\\_PORT” on page 159](#).

**Returned parameters: parameter check**

If the verb does not execute because of a parameter error, CS/AIX returns the following parameters:

***primary\_rc***

AP\_PARAMETER\_CHECK

***secondary\_rc***

Possible values are:

**AP\_INVALID\_PORT\_NAME**

The *list\_options* parameter was set to AP\_LIST\_INCLUSIVE to list all entries starting from the supplied name, but the *port\_name* parameter was not valid.

**AP\_INVALID\_LIST\_OPTION**

The *list\_options* parameter was not set to a valid value.

Appendix B, [“Common return codes,” on page 661](#) lists further secondary return codes associated with AP\_PARAMETER\_CHECK, which are common to all NOF verbs.

**Returned parameters: other conditions**

Appendix B, [“Common return codes,” on page 661](#) lists further combinations of primary and secondary return codes that are common to all NOF verbs.

**QUERY\_PU**

QUERY\_PU returns information about local PUs and the links associated with them. This verb can be used to obtain information about a specific PU or about multiple PUs, depending on the options used.

**VCB structure**

```
typedef struct query_pu
{
    AP_UINT16      opcode;                /* verb operation code          */
    unsigned char  reserv2;               /* reserved                     */
    unsigned char  format;                /* reserved                     */
    AP_UINT16      primary_rc;            /* primary return code          */
    AP_UINT32      secondary_rc;          /* secondary return code        */
    unsigned char  *buf_ptr;              /* pointer to buffer            */
    AP_UINT32      buf_size;              /* buffer size                  */
    AP_UINT32      total_buf_size;        /* total buffer size required   */
    AP_UINT16      num_entries;           /* number of entries            */
    AP_UINT16      total_num_entries;     /* total number of entries      */
    unsigned char  list_options;          /* listing options              */
    unsigned char  reserv3;               /* reserved                     */
    unsigned char  pu_name[8];           /* PU name                      */
    unsigned char  host_attachment;       /* host attachment filter       */
} QUERY_PU;
```

```
typedef struct pu_data
{
    AP_UINT16      overlay_size;          /* size of returned entry       */
    unsigned char  pu_name[8];           /* PU name                      */
    unsigned char  description[32];      /* resource description         */
    unsigned char  reserv1[16];          /* reserved                     */
    unsigned char  ls_name[8];           /* LS name                      */
    unsigned char  pu_sscp_sess_active; /* Is PU-SSCP session active   */
    unsigned char  host_attachment;      /* Host attachment              */
    SESSION_STATS  pu_sscp_stats;        /* PU-SSCP session statistics   */
    unsigned char  sscp_id[6];           /* SSCP ID                      */
    unsigned char  conventional_lu_compression; /* compression for LU 0-3?    */
    unsigned char  conventional_lu_cryptography; /* reserved                   */
    unsigned char  dddlu_supported;      /* does the host support DDDL?  */
}
```

## QUERY\_PU

```
    unsigned char    tcpcv_supported;        /* does the host support TCPCVs? */
    unsigned char    dddlu_offline_supported; /* does the PU support sending */
    unsigned char    reserva[9];            /* NMVT (power off) to host? */
} PU_DATA;

typedef struct session_stats
{
    AP_UINT16        rcv_ru_size;            /* session receive RU size */
    AP_UINT16        send_ru_size;          /* session send RU size */
    AP_UINT16        max_send_btu_size;     /* maximum send BTU size */
    AP_UINT16        max_rcv_btu_size;     /* maximum rcv BTU size */
    AP_UINT16        max_send_pac_win;     /* maximum send pacing window size */
    AP_UINT16        cur_send_pac_win;     /* current send pacing window size */
    AP_UINT16        max_rcv_pac_win;     /* maximum receive pacing window */
    AP_UINT16        cur_rcv_pac_win;     /* current receive pacing window */
    AP_UINT32        send_data_frames;     /* number of data frames sent */
    AP_UINT32        send_fmd_data_frames; /* num fmd data frames sent */
    AP_UINT32        send_data_bytes;     /* number of data bytes sent */
    AP_UINT32        rcv_data_frames;     /* number of data frames received */
    AP_UINT32        rcv_fmd_data_frames; /* num fmd data frames received */
    AP_UINT32        rcv_data_bytes;     /* number of data bytes received */
    unsigned char    sidh;                /* session ID high byte (from */
    unsigned char    lsfsid;              /* LFSID) */
    unsigned char    sidl;                /* session ID low byte (from LFSID) */
    unsigned char    odai;                /* ODAI bit set */
    unsigned char    ls_name[8];          /* Link station name */
    unsigned char    pacing_type;         /* type of pacing in use */
} SESSION_STATS;
```

## Supplied parameters

The application supplies the following parameters:

### ***opcode***

AP\_QUERY\_PU

### ***buf\_ptr***

A pointer to a data buffer that CS/AIX will use to return the requested information.

### ***buf\_size***

Size of the supplied data buffer.

### ***num\_entries***

Maximum number of PUs for which data should be returned. To request data for a specific PU rather than a range, specify the value 1. To return as many entries as possible, specify zero; in this case, CS/AIX will return the maximum number of entries that can be accommodated in the supplied data buffer.

### ***list\_options***

The position in the list from which CS/AIX should begin to return data. Specify one of the following values:

#### **AP\_FIRST\_IN\_LIST**

Start at the first entry in the list.

#### **AP\_LIST\_INCLUSIVE**

Start at the entry specified by the *pu\_name* parameter.

#### **AP\_LIST\_FROM\_NEXT**

Start at the entry immediately following the entry specified by the *pu\_name* parameter.

For more information about how the list is ordered and how the application can obtain specific entries from it, see [“List options for QUERY\\_\\* Verbs”](#) on page 33.

### ***pu\_name***

Name of the PU for which information is required, or the name to be used as an index into the list of PUs. This value is ignored if *list\_options* is set to AP\_FIRST\_IN\_LIST. This is an 8-byte type-A EBCDIC string, padded on the right with spaces if the name is shorter than 8 characters.

**host\_attachment**

Specifies whether to filter the returned information by whether the PUs are attached to the host directly or using DLUR. Possible values are:

**AP\_DIRECT\_ATTACHED**

Return information only on PUs directly attached to the host system.

**AP\_DLUR\_ATTACHED**

Return information only on PUs supported by DLUR.

**AP\_NONE**

Return information about all PUs regardless of host attachment.

**Returned parameters: successful execution**

If the verb executes successfully, CS/AIX returns the following parameters:

**primary\_rc**

AP\_OK

**buf\_size**

Length of the information returned in the supplied buffer.

**total\_buf\_size**

Returned value indicating the size of buffer that would have been required to return all the list information requested. A value greater than *buf\_size* indicates that not all the available entries were returned.

**num\_entries**

Number of entries returned in the data buffer.

**total\_num\_entries**

Total number of entries available. A value greater than *num\_entries* indicates that not all the available entries were returned.

Each entry in the data buffer consists of the following parameters:

**pu\_data.overlay\_size**

The size of the returned *pu\_data* structure, and therefore the offset to the start of the next entry in the data buffer.

When your application needs to go through the returned buffer to find each *pu\_data* structure in turn, it must use this value to move to the correct offset for the next data structure, and must not use the `C sizeof()` operator. This is because the size of the returned overlay may increase in future releases of CS/AIX; using the returned overlay size ensures that your application will continue to work with future releases.

**pu\_data.pu\_name**

PU Name. This is an 8-byte type-A EBCDIC string, padded on the right with spaces if the name is shorter than 8 characters.

**pu\_data.description**

A null-terminated text string describing the PU, as specified in the definition of the LS or of the internal PU.

**pu\_data.ls\_name**

Name of the link station associated with this PU. This is an 8-byte ASCII string, padded on the right with spaces if the name is shorter than 8 bytes.

**pu\_data.pu\_sscp\_sess\_active**

Specifies whether the PU-SSCP session is active. Possible values are:

**AP\_YES**

The PU-SSCP session is active.

**AP\_NO**

The PU-SSCP session is inactive.

***pu\_data.host\_attachment***

Local PU host attachment type.

Possible values are:

**AP\_DIRECT\_ATTACHED**

PU is directly attached to the host system.

**AP\_DLUR\_ATTACHED**

PU is supported by DLUR.

***pu\_data.pu\_sscp\_stats.rcv\_ru\_size***

Reserved (always set to zero).

***pu\_data.pu\_sscp\_stats.send\_ru\_size***

Reserved (always set to zero).

***pu\_data.pu\_sscp\_stats.max\_send\_btu\_size***

Maximum BTU size that can be sent.

***pu\_data.pu\_sscp\_stats.max\_rcv\_btu\_size***

Maximum BTU size that can be received.

***pu\_data.pu\_sscp\_stats.max\_send\_pac\_win***

Reserved (always set to zero).

***pu\_data.pu\_sscp\_stats.cur\_send\_pac\_win***

Reserved (always set to zero).

***pu\_data.pu\_sscp\_stats.max\_rcv\_pac\_win***

Reserved (always set to zero).

***pu\_data.pu\_sscp\_stats.cur\_rcv\_pac\_win***

Reserved (always set to zero).

***pu\_data.pu\_sscp\_stats.send\_data\_frames***

Number of normal flow data frames sent.

***pu\_data.pu\_sscp\_stats.send\_fmd\_data\_frames***

Number of normal flow FMD data frames sent.

***pu\_data.pu\_sscp\_stats.send\_data\_bytes***

Number of normal flow data bytes sent.

***pu\_data.pu\_sscp\_stats.rcv\_data\_frames***

Number of normal flow data frames received.

***ppu\_data.pu\_sscp\_stats.rcv\_fmd\_data\_frames***

Number of normal flow FMD data frames received.

***pu\_data.pu\_sscp\_stats.rcv\_data\_bytes***

Number of normal flow data bytes received.

***pu\_data.pu\_sscp\_stats.sidh***

Session ID high byte.

***pu\_data.pu\_sscp\_stats.sidl***

Session ID low byte.

***pu\_data.pu\_sscp\_stats.odai***

Origin Destination Assignor Indicator. When bringing up a session, the sender of the BIND sets this field to zero if the local node contains the primary link station, and sets it to one if the BIND sender is the node containing the secondary link station.

***pu\_data.pu\_sscp\_stats.ls\_name***

Link station name associated with statistics. This is an 8-byte ASCII character string, right-padded with spaces if the name is shorter than 8 characters.

***pu\_data.pu\_sscp\_stats.pacing\_type***

The type of receive pacing in use on the PU-SSCP session. This parameter is set to AP\_NONE.

***pu\_data.sscp\_id***

For dependent LU sessions, this parameter is the SSCP ID received in the ACTPU from the host for the PU to which the local LU is mapped. For independent LU sessions, this parameter is set to 0 (zero). This value is an array of six bytes displayed as hexadecimal values.

***pu\_data.conventional\_lu\_compression***

Specifies whether data compression is requested for LU 0-3 sessions using this PU. Possible values are:

**AP\_YES**

Data compression should be used for LU 0-3 sessions using this PU if the host requests it.

**AP\_NO**

Data compression should not be used for LU 0-3 sessions using this PU.

***pu\_data.dddlu\_supported***

Specifies whether the host system supports DDDLU (Dynamic Definition of Dependent LUs). Possible values are:

**AP\_YES**

The host supports DDDLU.

**AP\_NO**

The host does not support DDDLU.

***pu\_data.tcpcv\_supported***

Specifies whether the host system supports receiving the TCP/IP Information Control Vector (0x64). CS/AIX can use this vector to send TCP/IP addressing information for TN3270 or LUA clients to the host. Possible values are:

**AP\_YES**

The host supports TCP CVs.

**AP\_NO**

The host does not support TCP CVs.

***pu\_data.dddlu\_offline\_supported***

Specifies whether the local PU supports sending NMVT (power off) messages to the host. If the host system supports DDDLU (Dynamic Definition of Dependent LUs), CS/AIX sends NMVT (power off) to the host when it has finished using a dynamically defined LU. This allows the host to save resources by removing the definition when it is no longer required.

Possible values are:

**AP\_YES**

The local PU sends NMVT (power off) messages to the host.

**AP\_NO**

The local PU does not send NMVT (power off) messages to the host.

## Returned parameters: parameter check

If the verb does not execute because of a parameter error, CS/AIX returns the following parameters:

***primary\_rc***

AP\_PARAMETER\_CHECK

***secondary\_rc***

Possible values are:

**AP\_INVALID\_PU\_NAME**

The *list\_options* parameter was set to AP\_LIST\_INCLUSIVE to list all entries starting from the supplied name, but the *pu\_name* parameter was not valid.

**AP\_INVALID\_LIST\_OPTION**

The *list\_options* parameter was not set to a valid value.

## QUERY\_RAPI\_CLIENTS

Appendix B, “Common return codes,” on page 661 lists further secondary return codes associated with AP\_PARAMETER\_CHECK, which are common to all NOF verbs.

### Returned parameters: state check

If the verb does not execute because of a state error, CS/AIX returns the following parameters.

#### *primary\_rc*

AP\_STATE\_CHECK

#### *secondary\_rc*

##### **AP\_INVALID\_PU\_TYPE**

The PU specified by the *pu\_name* parameter is a remote PU and not a local PU.

Appendix B, “Common return codes,” on page 661 lists further secondary return codes associated with AP\_STATE\_CHECK, which are common to all NOF verbs.

### Returned parameters: other conditions

Appendix B, “Common return codes,” on page 661 lists further combinations of primary and secondary return codes that are common to all NOF verbs.

## QUERY\_RAPI\_CLIENTS

QUERY\_RAPI\_CLIENTS returns information about Remote API Clients (on AIX, Linux, or Windows) for which a particular server on the CS/AIX LAN is currently acting as the controller.

This verb must be issued to a server. It does not matter whether the node is started on that server.

**Note:** If a client is connected to the server through a Web server, and the client software is stopped, there may be a delay of a minute or two before the Web server ends the connection to the CS/AIX controller server. This means that a QUERY\_RAPI\_CLIENTS verb may still include the client for a short time after it has stopped using the server.

### VCB structure

```
typedef struct query_rapi_clients
{
    AP_UINT16          opcode;           /* verb operation code          */
    unsigned char     reserv2;          /* reserved                      */
    unsigned char     format;           /* reserved                      */
    AP_UINT16          primary_rc;       /* primary return code          */
    AP_UINT32          secondary_rc;     /* secondary return code        */
    unsigned char     *buf_ptr;         /* pointer to buffer            */
    AP_UINT32          buf_size;         /* buffer size                  */
    AP_UINT32          total_buf_size;  /* total buffer size required   */
    AP_UINT16          num_entries;      /* number of entries            */
    AP_UINT16          total_num_entries; /* total number of entries      */
    unsigned char     list_options;     /* listing options              */
    AP_UINT16          max_clients;      /* maximum number of clients    */
    unsigned char     sys_name[128];    /* RAPI Client to start query   */
} QUERY_RAPI_CLIENTS;
```

```
typedef struct rapi_client_info
{
    AP_UINT16          overlay_size;     /* overlay size                  */
    unsigned char     sys_name[128];    /* RAPI Client System name      */
    SNA_IP_ADDR       rapi_client_origin_ip_addr; /* IP addr client sends us    */
    SNA_IP_ADDR       rapi_client_adj_ip_addr; /* IP addr client comes in on */
    AP_UINT16          rapi_client_adj_port; /* port IP client comes in on */
} RAPI_CLIENT_INFO;
```

```
typedef struct sna_ip_addr
{
    AP_UINT16          family;           /* IPv4 or IPv6                 */
    union
    {

```



```

    unsigned char  ipv4_addr[4];
    unsigned char  ipv6_addr[16];
  } ip_addr;
} SNA_IP_ADDR;

```

## Supplied parameters

The application supplies the following parameters:

### ***opcode***

AP\_QUERY\_RAPI\_CLIENTS

### ***buf\_ptr***

A pointer to a data buffer that CS/AIX will use to return the requested information.

### ***buf\_size***

Size of the supplied data buffer.

### ***num\_entries***

Maximum number of clients for which data should be returned. To request data for a specific client rather than a range, specify the value 1. To return as many entries as possible, specify zero; in this case, CS/AIX will return the maximum number of entries that can be accommodated in the supplied data buffer.

### ***list\_options***

The position in the list from which CS/AIX should begin to return data. Possible values are:

#### **AP\_FIRST\_IN\_LIST**

Start at the first entry in the list of clients.

#### **AP\_LIST\_INCLUSIVE**

Start at the entry specified by the *sys\_name* parameter.

#### **AP\_LIST\_FROM\_NEXT**

Start at the entry immediately following the entry specified by the *sys\_name* parameter.

### ***sys\_name***

Fully-qualified system name of the client to be used as an index into the list (such as `newbox.this.co.uk`). This parameter is ignored if *list\_options* is set to `AP_FIRST_IN_LIST`.

This is an ASCII string of 1-128 characters, padded on the right with spaces if the name is shorter than 128 characters.

## Returned parameters: successful execution

If the verb executes successfully, CS/AIX returns the following parameters:

### ***primary\_rc***

AP\_OK

### ***buf\_size***

Length of the information returned in the supplied buffer.

### ***total\_buf\_size***

Returned value indicating the size of buffer that would have been required to return all the list information requested. A value greater than *buf\_size* indicates that not all the available entries were returned.

### ***num\_entries***

Number of entries returned in the data buffer.

### ***total\_num\_entries***

Total number of entries available. A value greater than *num\_entries* indicates that not all the available entries were returned.

Each entry in the data buffer consists of the following parameters:

### ***max\_clients***

The maximum number of clients using the server as their controller server at any time since the CS/AIX software was started.

### ***rapi\_client\_info.overlay\_size***

The size of the returned `rapi_client_info` structure, and therefore the offset to the start of the next entry in the data buffer.

When your application needs to go through the returned buffer to find each `rapi_client_info` structure in turn, it must use this value to move to the correct offset for the next data structure, and must not use the C `sizeof()` operator. This is because the size of the returned overlay may increase in future releases of CS/AIX; using the returned overlay size ensures that your application will continue to work with future releases.

### ***rapi\_client\_info.sys\_name***

The fully-qualified system name of the client (such as `newbox.this.co.uk`).

### ***rapi\_client\_info.rapi\_client\_origin\_ip\_addr***

The IP address of the client.

### ***rapi\_client\_info.rapi\_client\_origin\_ip\_addr.family***

The type of TCP/IP address specified for the client. Possible values are as follows.

#### **AF\_INET**

IPv4 address, specified as a dotted-decimal address (such as `193.1.11.100`).

#### **AF\_INET6**

IPv6 address, specified as a colon-hexadecimal address (such as `2001:0db8:0000:0000:0000:0000:1428:57ab` or `2001:db8::1428:57ab`).

**Note:** The values `AF_INET` and `AF_INET6` are taken from a system header file, and are not standard `AP_*` values defined by CS/AIX. The system header file is `/usr/include/sys/socket.h` on an AIX server or client, and `/usr/include/linux/socket.h` on a Linux client.

If your NOF application needs to test against these values, you should use `#include` to include this system file in addition to the `nof_c.h` header file.

### ***rapi\_client\_info.rapi\_client\_origin\_ip\_addr.ip\_addr.ipv4\_addr***

This field is used only if the *family* parameter is set to `AF_INET`. The IPv4 (dotted-decimal) address of the client computer.

### ***rapi\_client\_info.rapi\_client\_origin\_ip\_addr.ip\_addr.ipv6\_addr***

This field is used only if the *family* parameter is set to `AF_INET6`. The IPv6 (colon-hexadecimal) address of the client computer.

### ***rapi\_client\_info.rapi\_client\_adj\_ip\_addr***

The IP address through which the client attaches to CS/AIX. This may not be the same as *rapi\_client\_origin\_ip\_addr* if one of the following is true.

- The client connects through a Web server.
- The client connects through a TCP/IP proxy or NAT router, such as the Linux iptables tool.
- The client has multiple IP addresses.

### ***rapi\_client\_info.rapi\_client\_adj\_ip\_addr.family***

The type of TCP/IP address through which the client attaches to CS/AIX. Possible values are as follows.

#### **AF\_INET**

IPv4 address, specified as a dotted-decimal address (such as `193.1.11.100`).

#### **AF\_INET6**

IPv6 address, specified as a colon-hexadecimal address (such as `2001:0db8:0000:0000:0000:0000:1428:57ab` or `2001:db8::1428:57ab`).

**Note:** The values `AF_INET` and `AF_INET6` are taken from a system header file, and are not standard `AP_*` values defined by CS/AIX. The system header file is `/usr/include/sys/socket.h` on an AIX server or client, and `/usr/include/linux/socket.h` on a Linux client.

If your NOF application needs to test against these values, you should use `#include` to include this system file in addition to the `nof_c.h` header file.

***rapi\_client\_info.rapi\_client\_adj\_ip\_addr.ip\_addr.ipv4\_addr***

This field is used only if the *family* parameter is set to `AF_INET`. The IPv4 (dotted-decimal) address through which the client attaches to CS/AIX.

***rapi\_client\_info.rapi\_client\_adj\_ip\_addr.ip\_addr.ipv6\_addr***

This field is used only if the *family* parameter is set to `AF_INET6`. The IPv6 (colon-hexadecimal) address through which the client attaches to CS/AIX.

***rapi\_client\_info.rapi\_client\_adj\_port***

The IP port number through which the client attaches to CS/AIX.

## Returned parameters: parameter check

If the verb does not execute because of a parameter error, CS/AIX returns the following parameters:

***primary\_rc***

`AP_PARAMETER_CHECK`

***secondary\_rc***

Possible values are:

***AP\_INVALID\_LIST\_OPTION***

The *list\_options* parameter was not set to a valid value.

***AP\_INVALID\_NODE\_NAME***

The *list\_options* parameter was set to `AP_LIST_INCLUSIVE` or `AP_LIST_FROM_NEXT` to list all entries starting from the supplied node name, but the *sys\_name* parameter was not specified or was not valid.

Appendix B, “Common return codes,” on page 661 lists further secondary return codes associated with `AP_PARAMETER_CHECK`, which are common to all NOF verbs.

## Returned parameters: other conditions

Appendix B, “Common return codes,” on page 661 lists further combinations of primary and secondary return codes that are common to all NOF verbs.

## QUERY\_RCF\_ACCESS

`QUERY_RCF_ACCESS` returns information about the permitted access to the CS/AIX Remote Command Facility (RCF): the user ID used to run UNIX Command Facility (UCF) commands, and the restrictions on which administration commands can be issued using the Service Point Command Facility (SPCF). This information was previously set up using `DEFINE_RCF_ACCESS`. For more information about SPCF and UCF, see the *IBM Communications Server for Data Center Deployment on AIX Administration Guide*.

This verb must be issued to the domain configuration file.

## VCB structure

```
typedef struct query_rcf_access
{
    AP_UINT16      opcode;           /* Verb operation code      */
    unsigned char  reserv2;         /* reserved                  */
    unsigned char  format;         /* reserved                  */
    AP_UINT16      primary_rc;     /* primary return code      */
    AP_UINT32      secondary_rc;   /* secondary return code    */
    unsigned char  ucf_username[32]; /* UCF username             */
    AP_UINT32      spcf_permissions; /* SPCF permissions        */
    unsigned char  reserv3[8];     /* Reserved                  */
} QUERY_RCF_ACCESS;
```

### Supplied parameters

The application supplies the following parameters:

***opcode***

AP\_QUERY\_RCF\_ACCESS

### Returned parameters: successful execution

If the verb executes successfully, CS/AIX returns the following parameters:

***primary\_rc***

AP\_OK

***ucf\_username***

Specifies the AIX user name of the UCF user. This parameter is a null-terminated ASCII string.

All UCF commands will be run using this user's user ID, using the default shell and access permissions defined for this user.

If this parameter is set to a null string, this indicates that UCF access is prohibited.

***spcf\_permissions***

Specifies the types of CS/AIX administration commands that can be accessed using SPCF. This is set to AP\_NONE to indicate that SPCF access is prohibited, or to one or more of the following values (combined using a logical OR):

**AP\_ALLOW\_QUERY\_LOCAL**

QUERY\_\* verbs are permitted.

**AP\_ALLOW\_DEFINE\_LOCAL**

DEFINE\_\*, SET\_\*, DELETE\_\*, ADD\_\*, and REMOVE\_\* verbs, and also INIT\_NODE, are permitted.

**AP\_ALLOW\_ACTION\_LOCAL**

"Action" verbs are permitted: START\_\*, STOP\_\*, ACTIVATE\_\*, DEACTIVATE\_\*, and also APING, INITIALIZE\_SESSION\_LIMIT, CHANGE\_SESSION\_LIMIT, and RESET\_SESSION\_LIMIT.

**AP\_ALLOW\_QUERY\_REMOTE**

The QUERY\_\* verbs are allowed to provide access to a remote CS/AIX node.

**AP\_ALLOW\_DEFINE\_REMOTE**

The DEFINE\_\*, SET\_\*, DELETE\_\*, ADD\_\*, REMOVE\_\*, and INIT\_NODE verbs are allowed to provide access to a remote CS/AIX node.

**AP\_ALLOW\_ACTION\_REMOTE**

The START\_\*, STOP\_\*, ACTIVATE\_\*, DEACTIVATE\_\*, APING, INITIALIZE\_SESSION\_LIMIT, CHANGE\_SESSION\_LIMIT, and RESET\_SESSION\_LIMIT verbs are allowed to provide access to a remote CS/AIX node.

### Returned parameters: other conditions

Appendix B, "Common return codes," on [page 661](#) lists further combinations of primary and secondary return codes that are common to all NOF verbs.

## QUERY\_RTP\_CONNECTION

---

The QUERY\_RTP\_CONNECTION verb returns a list of information about Rapid Transport Protocol (RTP) connections for which the node is an endpoint. This verb can be used to obtain summary or detailed information about a specific RTP connection or about multiple RTP connections, depending on the options used.

This verb must be issued to a running node.

## VCB structure

```

typedef struct query_rtp_connection
{
    AP_UINT16      opcode;                /* verb operation code          */
    unsigned char  reserv2;               /* reserved                      */
    unsigned char  format;                /* reserved                      */
    AP_UINT16      primary_rc;            /* primary return code          */
    AP_UINT32      secondary_rc;          /* secondary return code        */
    unsigned char  *buf_ptr;              /* pointer to buffer            */
    AP_UINT32      buf_size;              /* buffer size                  */
    AP_UINT32      total_buf_size;        /* total buffer size required   */
    AP_UINT16      num_entries;           /* number of entries            */
    AP_UINT16      total_num_entries;     /* total number of entries      */
    unsigned char  list_options;          /* listing options              */
    unsigned char  reserv3;               /* reserved                      */
    unsigned char  rtp_name[8];           /* name of RTP connection      */
} QUERY_RTP_CONNECTION;

```

```

typedef struct rtp_connection_summary
{
    AP_UINT16      overlay_size;          /* size of returned entry      */
    unsigned char  rtp_name[8];           /* RTP connection name         */
    unsigned char  first_hop_ls_name[8]; /* LS name of first hop        */
    unsigned char  dest_node_name[17];    /* fully qualified name of     */
                                          /* destination node            */
    unsigned char  connection_type;       /* LU-LU or CP-CP connection? */
    unsigned char  cos_name[8];           /* class of service name       */
    AP_UINT16      num_sess_active;       /* number of active sessions   */
} RTP_CONNECTION_SUMMARY;

```

```

typedef struct rtp_connection_detail
{
    AP_UINT16      overlay_size;          /* size of returned entry      */
    unsigned char  rtp_name[8];           /* RTP connection name         */
    unsigned char  first_hop_ls_name[8]; /* LS name of first hop        */
    unsigned char  dest_node_name[17];    /* fully qualified name of     */
                                          /* destination node            */
    unsigned char  isr_boundary_fn;       /* is conn used for Boundary Func? */
    unsigned char  connection_type;       /* LU-LU or CP-CP connection? */
    unsigned char  reserv1;               /* reserved                      */
    unsigned char  cos_name[8];           /* class of service name       */
    AP_UINT16      max_btu_size;          /* maximum BTU size            */
    AP_UINT32      liveness_timer;        /* liveness timer              */
    unsigned char  local_tcid[8];         /* local tcid                   */
    unsigned char  remote_tcid[8];        /* remote tcid                  */
    RTP_STATISTICS rtp_stats;             /* RTP statistics              */
    AP_UINT16      num_sess_active;       /* number of active sessions   */
    unsigned char  arb_mode;              /* ARB-S, ARB-R, ARB-P?       */
    unsigned char  refifo;                /* refifo support?             */
    AP_UINT32      refifo_timer;           /* last refifo timer in ms     */
    AP_UINT32      path_switch_time;      /* time since last path switch secs */
    AP_UINT16      path_switch_atts;      /* number of path switch attempts */
    unsigned char  reserv2[4];            /* reserved                      */
    AP_UINT16      rscv_len;              /* length of appended RSCV     */
} RTP_CONNECTION_DETAIL;

```

The session detail structure may be followed by a Route Selection Control Vector (RSCV) as defined by SNA Formats. This control vector defines the session route through the network and is carried on the BIND. This RSCV is included only if the node's configuration (specified using DEFINE\_NODE) indicates that endpoint RSCVs should be stored.

```

typedef struct rtp_statistics
{
    AP_UINT32      bytes_sent;             /* total number of bytes sent   */
    AP_UINT32      bytes_received;        /* total number of bytes received */
    AP_UINT32      bytes_resent;          /* total number of bytes resent  */
    AP_UINT32      bytes_discarded;       /* total number of bytes discarded */
    AP_UINT32      packets_sent;          /* total number of packets sent  */
    AP_UINT32      packets_received;      /* total number of packets received */
    AP_UINT32      packets_resent;        /* total number of packets resent */
    AP_UINT32      packets_discarded;     /* total number of packets discarded */
    AP_UINT32      gaps_detected;         /* gaps detected                */
    AP_UINT32      send_rate;             /* current send rate            */
    AP_UINT32      max_send_rate;         /* maximum send rate            */
    AP_UINT32      min_send_rate;         /* minimum send rate            */
}

```

## QUERY\_RTP\_CONNECTION

```
AP_UINT32 receive_rate; /* current send rate */
AP_UINT32 max_receive_rate; /* maximum receive rate */
AP_UINT32 min_receive_rate; /* minimum receive rate */
AP_UINT32 burst_size; /* current burst size */
AP_UINT32 up_time; /* total uptime of connection */
AP_UINT32 smooth_rtt; /* smoothed round-trip time */
AP_UINT32 last_rtt; /* last round-trip time */
AP_UINT32 short_req_timer; /* SHORT_REQ timer duration */
AP_UINT32 short_req_timeouts; /* number of SHORT_REQ timeouts */
AP_UINT32 liveness_timeouts; /* number of liveness timeouts */
AP_UINT32 in_invalid_sna_frames; /* number of invalid SNA frames */
AP_UINT32 in_sc_frames; /* number of SC frames received */
AP_UINT32 out_sc_frames; /* number of SC frames sent */
AP_INT32 delay_change_sum; /* delay change sum */
AP_UINT32 current_receiver_threshold; /* current ARB-R receiver threshold */
AP_UINT32 minimum_receiver_threshold; /* minimum ARB-R receiver threshold */
AP_UINT32 maximum_receiver_threshold; /* maximum ARB-R receiver threshold */
AP_UINT32 sent_normals_count; /* number of NORMALs sent */
AP_UINT32 sent_slowdowns_count; /* number of SLOWDOWNs sent */
AP_UINT32 rcvd_normals_count; /* number of NORMALs received */
AP_UINT32 rcvd_slowdowns_count; /* number of SLOWDOWNs received */
AP_UINT32 dcs_reset_count_non_heal; /* number of non-healing resets */
AP_UINT16 dcs_reset_count_healing; /* number of self-healing resets */
unsigned char arb_mode; /* ARB mode (GREEN, YELLOW, RED) */
unsigned char reserve[1]; /* reserved */
} RTP_STATISTICS;
```

## Supplied parameters

Supplied parameters are:

### ***opcode***

AP\_QUERY\_RTP\_CONNECTION

### ***buf\_ptr***

Pointer to a buffer into which list information can be written. The application can append data to the end of the VCB in which case, *buf\_ptr* must be set to NULL.

### ***buf\_size***

Size of the buffer supplied.

### ***num\_entries***

Maximum number of RTP connections for which data should be returned. To request data for a specific connection rather than a range, specify the value 1. To return as many entries as possible, specify zero; in this case, CS/AIX will return the maximum number of entries that can be accommodated in the supplied data buffer.

### ***list\_options***

The level of information required for each entry and the position in the list from which CS/AIX begins to return data.

Specify the level of information required with one of the following values:

#### **AP\_SUMMARY**

Summary information only.

#### **AP\_DETAIL**

Detailed information.

Combine this value using a logical OR operation with one of the following values:

#### **AP\_FIRST\_IN\_LIST**

Start at the first entry in the list.

#### **AP\_LIST\_INCLUSIVE**

Start at the entry specified by the *rtp\_name* parameter.

**AP\_LIST\_FROM\_NEXT**

Start at the entry immediately following the entry specified by the *rtp\_name* parameter.

***rtp\_name***

Name of the RTP connection. This value is ignored if the *list\_options* parameter is set to AP\_FIRST\_IN\_LIST. This is an 8-byte ASCII string, padded on the right with spaces if the name is shorter than 8 bytes.

**Returned parameters: successful execution**

If the verb executes successfully, CS/AIX returns the following parameters:

***primary\_rc***

AP\_OK

***buf\_size***

Length of the information returned in the buffer.

***total\_buf\_size***

Returned value indicating the size of buffer that would have been required to return all the list information requested. This may be higher than *buf\_size*.

***num\_entries***

The number of entries actually returned.

***total\_num\_entries***

Total number of entries that could have been returned. This may be higher than *num\_entries*.

***rtp\_connection\_summary.overlay\_size***

The size of the returned *rtp\_connection* structure, and therefore the offset to the start of the next entry in the data buffer.

When your application needs to go through the returned buffer to find each *rtp\_connection\_summary* structure in turn, it must use this value to move to the correct offset for the next data structure, and must not use the C `sizeof()` operator. This is because the size of the returned overlay may increase in future releases of CS/AIX; using the returned overlay size ensures that your application will continue to work with future releases.

***rtp\_connection\_summary.rtp\_name***

Name of the RTP connection. This is an 8-byte ASCII string, padded on the right with spaces if the name is shorter than 8 bytes.

***rtp\_connection\_summary.first\_hop\_ls\_name***

Name of the link station of the first hop of the RTP connection. This is an 8-byte ASCII string, padded on the right with spaces if the name is shorter than 8 bytes.

***rtp\_connection\_summary.dest\_node\_name***

Fully qualified name of the destination control point for the RTP portion of the session. The name is a 17-byte EBCDIC string, right-padded with EBCDIC spaces. It consists of a network ID of up to 8 A-string characters, an EBCDIC dot (period) character, and a network name of up to 8 A-string characters.

***rtp\_connection\_summary.connection\_type***

Specifies the type of sessions on the RTP connection. Possible values are:

**AP\_RTP\_CP\_CP\_SESSION**

The RTP connection carries CP-CP sessions.

**AP\_RTP\_LU\_LU\_SESSION**

The RTP connection carries LU-LU sessions.

**AP\_RTP\_ROUTE\_SETUP**

The RTP connection is used for route setup.

***rtp\_connection\_summary.cos\_name***

Name of the class of service used by the RTP connection. This name is an EBCDIC string padded on the right with EBCDIC spaces.

### ***rtp\_connection\_summary.num\_sess\_active***

Number of sessions active on this RTP connection.

### ***rtp\_connection\_detail.overlay\_size***

The size of the returned `rtp_connection` structure, and therefore the offset to the start of the next entry in the data buffer.

When your application needs to go through the returned buffer to find each `rtp_connection_detail` structure in turn, it must use this value to move to the correct offset for the next data structure, and must not use the C `sizeof()` operator. This is because the size of the returned overlay may increase in future releases of CS/AIX; using the returned overlay size ensures that your application will continue to work with future releases.

### ***rtp\_connection\_detail.rtp\_name***

Name of the RTP connection. This is an 8-byte ASCII string, padded on the right with spaces if the name is shorter than 8 bytes.

### ***rtp\_connection\_detail.first\_hop\_ls\_name***

Name of the link station of the first hop of the RTP connection. This is an 8-byte ASCII string, padded on the right with spaces if the name is shorter than 8 bytes.

### ***rtp\_connection\_detail.dest\_node\_name***

Fully qualified name of the destination control point for the RTP portion of the session. The name is a 17-byte EBCDIC string, right-padded with EBCDIC spaces. It consists of a network ID of up to 8 A-string characters, an EBCDIC dot (period) character, and a network name of up to 8 A-string characters.

### ***rtp\_connection\_detail.isr\_boundary\_fn***

Specifies whether the RTP Connection is being used for any ISR session for which the local node is providing HPR-APPN Boundary Function. Possible values are:

#### **AP\_YES**

The RTP connection is being used for an ISR session for which the local node is providing HPR-APPN Boundary Function.

#### **AP\_NO**

The RTP connection is not being used for an ISR session for which the local node is providing HPR-APPN Boundary Function.

### ***rtp\_connection\_detail.connection\_type***

Specifies the type of sessions on the RTP connection. Possible values are:

#### **AP\_RTP\_CP\_CP\_SESSION**

The RTP connection carries CP-CP sessions.

#### **AP\_RTP\_LU\_LU\_SESSION**

The RTP connection carries LU-LU sessions.

#### **AP\_RTP\_ROUTE\_SETUP**

The RTP connection is used for route setup.

### ***rtp\_connection\_detail.cos\_name***

Name of the class of service used by the RTP connection. This name is an EBCDIC string padded on the right with EBCDIC spaces.

### ***rtp\_connection\_detail.max\_btu\_size***

Maximum size, in bytes, of the basic transmission unit (BTU) used on the RTP connection.

### ***rtp\_connection\_detail.liveness\_timer***

Liveness timer, measured in seconds, for the RTP connection. If no traffic flows on a connection during a liveness timer interval, RTP starts a status exchange to check if its partner is still there. A short liveness timer interval provides quick detection of line failures and rapid path switching when a line fails. However, if the interval is too short, performance is slightly degraded by the frequent checks on the status of the line.

### ***rtp\_connection\_detail.local\_tcid***

Local TCID (transport control identifier) for the RTP connection.



***rtp\_connection\_detail.remote\_tcid***

Remote TCID for the RTP connection.

***rtp\_connection\_detail.rtp\_stats.bytes\_sent***

Total number of bytes that the local node has sent on this RTP connection.

***rtp\_connection\_detail.rtp\_stats.bytes\_received***

Total number of bytes that the local node has received on this RTP connection.

***rtp\_connection\_detail.rtp\_stats.bytes\_resent***

Total number of bytes that the local node has resent on this RTP connection because bytes were lost in transit.

***rtp\_connection\_detail.rtp\_stats.bytes\_discarded***

Total number of bytes sent by the other end of the RTP connection that were discarded as duplicates of data already received.

***rtp\_connection\_detail.rtp\_stats.packets\_sent***

Total number of packets that the local node has sent on this RTP connection.

***rtp\_connection\_detail.rtp\_stats.packets\_received***

Total number of packets that the local node has received on this RTP connection.

***rtp\_connection\_detail.rtp\_stats.packets\_resent***

Total number of packets that the local node has resent on this RTP connection because packets were lost in transit.

***rtp\_connection\_detail.rtp\_stats.packets\_discarded***

Total number of packets sent by the other end of the RTP connection that were discarded as duplicates of data already received.

***rtp\_connection\_detail.rtp\_stats.gaps\_detected***

Total number of gaps detected by the local node. Each gap corresponds to one or more lost frames.

***rtp\_connection\_detail.rtp\_stats.send\_rate***

Current send rate on this RTP connection, measured in Kbits/second. This rate is the maximum allowed send rate as calculated by the ARB (adaptive rate-based) algorithm. RTP uses the ARB algorithm to calculate how fast it can send data based on an analysis of the amount of time it takes for the partner to respond.

***rtp\_connection\_detail.rtp\_stats.max\_send\_rate***

Maximum send rate on this RTP connection, measured in Kbits/second.

***rtp\_connection\_detail.rtp\_stats.min\_send\_rate***

Minimum send rate on this RTP connection, measured in Kbits/second.

***rtp\_connection\_detail.rtp\_stats.receive\_rate***

Current receive rate on this RTP connection, measured in Kbits/second. This rate is the actual rate calculated over the last measurement interval.

***rtp\_connection\_detail.rtp\_stats.max\_receive\_rate***

Maximum receive rate on this RTP connection, measured in Kbits/second.

***rtp\_connection\_detail.rtp\_stats.min\_receive\_rate***

Minimum receive rate on this RTP connection, measured in Kbits/second.

***rtp\_connection\_detail.rtp\_stats.burst\_size***

Current burst size on this RTP connection, measured in bytes.

***rtp\_connection\_detail.rtp\_stats.up\_time***

Total number of seconds this RTP connection has been active.

***rtp\_connection\_detail.rtp\_stats.smooth\_rtt***

Smoothed measure of round-trip time between the local node and the partner RTP node, measured in milliseconds.

***rtp\_connection\_detail.rtp\_stats.last\_rtt***

The last measured round-trip time between the local node and the partner RTP node, measured in milliseconds.

***rtp\_connection\_detail.rtp\_stats.short\_req\_timer***

The amount of time to wait for a response to a request for a status exchange, measured in milliseconds. A short timer interval provides quick detection of failures but lowers performance.

***rtp\_connection\_detail.rtp\_stats.short\_req\_timeouts***

Total number of times the *short\_req\_timer* has expired for this RTP connection.

***rtp\_connection\_detail.rtp\_stats.liveness\_timeouts***

Total number of times the liveness timer has expired for this RTP connection. The liveness timer expires when the connection has been idle for the period specified in the *liveness\_timer* parameter.

***rtp\_connection\_detail.rtp\_stats.in\_invalid\_sna\_frames***

Total number of SNA frames received and discarded on this RTP connection because they were not valid.

***rtp\_connection\_detail.rtp\_stats.in\_sc\_frames***

Total number of session control frames received on this RTP connection.

***rtp\_connection\_detail.rtp\_stats.out\_sc\_frames***

Total number of session control frames sent on this RTP connection.

***rtp\_connection\_detail.rtp\_stats.delay\_change\_sum***

Value of the delay change sum currently held by the ARB-R algorithm on this RTP connection.

***rtp\_connection\_detail.rtp\_stats.current\_receiver\_threshold***

Value of the receiver threshold currently held by the ARB-R algorithm on this RTP connection.

***rtp\_connection\_detail.rtp\_stats.minimum\_receiver\_threshold***

Value of the minimum receiver threshold currently held by the ARB-R algorithm on this RTP connection.

***rtp\_connection\_detail.rtp\_stats.maximum\_receiver\_threshold***

Value of the maximum receiver threshold currently held by the ARB-R algorithm on this RTP connection.

***rtp\_connection\_detail.rtp\_stats.sent\_normals\_count***

Number of NORMAL feedback ARB-R segments sent by the ARB-R algorithm on this RTP connection.

***rtp\_connection\_detail.rtp\_stats.sent\_slowdowns\_count***

Number of SLOWDOWN1 and SLOWDOWN2 feedback ARB-R segments sent by the ARB-R algorithm on this RTP connection.

***rtp\_connection\_detail.rtp\_stats.rcvd\_normals\_count***

Number of NORMAL feedback ARB-R segments received by the ARB-R algorithm on this RTP connection.

***rtp\_connection\_detail.rtp\_stats.rcvd\_slowdowns\_count***

Number of SLOWDOWN1 and SLOWDOWN2 feedback ARB-R segments received by the ARB-R algorithm on this RTP connection.

***rtp\_connection\_detail.rtp\_stats.dcs\_reset\_count\_non\_heal***

Number of delay change sum resets made as a part of normal ARB-R processing on this RTP connection.

***rtp\_connection\_detail.rtp\_stats.dcs\_reset\_count\_healing***

Number of delay change sum resets made to self-heal the ARB-R algorithm on this RTP connection.

***rtp\_connection\_detail.rtp\_stats.arb\_mode***

The current ARB-R status mode on this RTP connection. Possible values are:

- 0** GREEN
- 1** YELLOW
- 2** RED

***rtp\_connection\_detail.num\_sess\_active***

Number of sessions active on this RTP connection.

***rtp\_connection\_detail.arb\_mode***

Specifies the ARB mode in use on this RTP Connection. Possible values are:

**AP\_ARB\_S**

Standard mode ARB.

**AP\_ARB\_R**

Responsive mode ARB.

**AP\_ARB\_P**

Progressive mode ARB.

**AP\_UNKNOWN**

The ARB mode has not yet been determined because the RTP connection is not yet established.

***rtp\_connection\_detail.refifo***

Specifies whether refifo is enabled on the RTP connection. Possible values are:

**AP\_YES**

Refifo is enabled. When CS/AIX detects a gap in received data, it starts the refifo timer to allow time for out-of-sequence packets to arrive, and requests retransmission only if the packets are still missing when the timer expires.

**AP\_NO**

Refifo is not enabled. When CS/AIX detects a gap in received data, it requests retransmission of the missing packets immediately.

***rtp\_connection\_detail.refifo\_timer***

The most recent refifo timer duration, in milliseconds.

***rtp\_connection\_detail.path\_switch\_time***

The time in seconds since the most recent path switch attempt on this RTP connection. If there have been no path switch attempts (*path\_switch\_atts* is set to zero), this parameter is set to zero.

***rtp\_connection\_detail.path\_switch\_atts***

The total number of path switch attempts made on this RTP connection.

## Returned parameters: parameter check

If the verb does not execute because of a parameter error, CS/AIX returns the following parameters:

***primary\_rc***

AP\_PARAMETER\_CHECK

***secondary\_rc***

Possible values are:

**AP\_INVALID\_RTP\_CONNECTION**

The *list\_options* parameter was set to AP\_LIST\_INCLUSIVE to list all entries starting from the supplied name, but the *rtp\_name* parameter was not valid.

Appendix B, “Common return codes,” on page 661 lists further secondary return codes associated with AP\_PARAMETER\_CHECK, which are common to all NOF verbs.

## Returned parameters: other conditions

Appendix B, “Common return codes,” on page 661 lists further combinations of primary and secondary return codes that are common to all NOF verbs.

## QUERY\_RTP\_TUNING

---

QUERY\_RTP\_TUNING returns information about the parameters that will be used for future RTP connections. This information was previously set up using DEFINE\_RTP\_TUNING.

## VCB structure

```
typedef struct query_rtp_tuning
{
    AP_UINT16      opcode;           /* Verb operation code          */
    unsigned char  reserv2;         /* reserved                     */
    unsigned char  format;         /* reserved                     */
    AP_UINT16      primary_rc;     /* primary return code          */
    AP_UINT32      secondary_rc;   /* secondary return code        */
    unsigned char  path_switch_attempts; /* number of path switch attempts */
    unsigned char  short_req_retry_limit; /* short request timer retry limit */
    AP_UINT16      path_switch_times[4]; /* path switch times            */
    AP_UINT32      refifo_cap;     /* maximum for refifo timer     */
    AP_UINT32      srt_cap;        /* maximum for short request timer */
    AP_UINT16      path_switch_delay; /* minimum delay before path switch*/
    unsigned char  reserved[78];   /* reserved                     */
} QUERY_RTP_TUNING;
```

## Supplied parameters

The application supplies the following parameters:

### ***opcode***

AP\_QUERY\_RTP\_TUNING

## Returned parameters: successful execution

If the verb executes successfully, CS/AIX returns the following parameters:

### ***primary\_rc***

AP\_OK

### ***path\_switch\_attempts***

Number of path switch attempts to set on new RTP connections.

### ***short\_req\_retry\_limit***

Number of times a Status Request is sent before CS/AIX determines that an RTP connection is disconnected and starts Path Switch processing.

### ***path\_switch\_times***

Length of time in seconds for which CS/AIX attempts to path switch a disconnected RTP connection. This parameter is specified as four separate time limits for each of the valid transmission priorities in order: AP\_LOW, AP\_MEDIUM, AP\_HIGH, and AP\_NETWORK.

### ***refifo\_cap***

The RTP protocol uses a timer called the Re-FIFO Timer. The value of this timer is calculated as part of the protocol, but this parameter specifies a maximum value in milliseconds beyond which the timer cannot increase. In some situations, setting this maximum value can improve performance. A value of 0 (zero) means that the timer is not limited and can take any value calculated by the protocol.

### ***srt\_cap***

The RTP protocol uses a timer called the Short Request Timer. The value of this timer is calculated as part of the protocol, but this parameter specifies a maximum value in milliseconds beyond which the timer cannot increase. In some situations, setting this maximum value can improve performance. A value of 0 (zero) means that the timer is not limited and can take any value calculated by the protocol.

### ***path\_switch\_delay***

Minimum delay in seconds before a path switch occurs. Specifying a delay avoids unnecessary path switch attempts caused by temporary resource shortages at the remote system, in particular when there is no other route available.

The default value for this parameter is zero, indicating that a path switch attempt can occur as soon as the protocol indicates it is required.

## Returned parameters: other conditions

Appendix B, “Common return codes,” on page 661 lists further combinations of primary and secondary return codes that are common to all NOF verbs.

## QUERY\_SECURITY\_ACCESS\_LIST

QUERY\_SECURITY\_ACCESS\_LIST returns information about security access lists defined in a CS/AIX configuration file. It can return information about a single list or multiple lists, depending on the options used.

### VCB structure

```
typedef struct query_security_access_list
{
    AP_UINT16      opcode;                /* verb operation code          */
    unsigned char  reserv2;               /* reserved                     */
    unsigned char  format;                /* reserved                     */
    AP_UINT16      primary_rc;            /* primary return code          */
    AP_UINT32      secondary_rc;          /* secondary return code        */
    unsigned char  *buf_ptr;              /* pointer to buffer            */
    AP_UINT32      buf_size;              /* buffer size                  */
    AP_UINT32      total_buf_size;        /* total buffer size required    */
    AP_UINT16      num_entries;           /* number of entries            */
    AP_UINT16      total_num_entries;     /* total number of entries      */
    unsigned char  list_options;          /* listing options              */
    unsigned char  reserv3;               /* reserved                     */
    unsigned char  list_name[14];         /* Security Access List name    */
    unsigned char  user_name[10];         /* user name                    */
    AP_UINT32      num_init_users;        /* number of users for first    */
    AP_UINT32      num_last_users;        /* number of users on last      */
    unsigned char  last_list_incomplete; /* set to AP_YES if user data   */
    } QUERY_SECURITY_ACCESS_LIST;
    /* for last list is incomplete */
```

```
typedef struct security_access_detail
{
    AP_UINT16      overlay_size;           /* size of returned entry       */
    unsigned char  list_name[14];         /* list name                    */
    unsigned char  reserv1[2];           /* reserved                     */
    AP_UINT32      num_filtered_users;    /* number of users returned     */
    SECURITY_LIST_DEF def_data;           /* list definition              */
    } SECURITY_ACCESS_DETAIL;
```

```
typedef struct security_list_def
{
    unsigned char  description[32];       /* description                   */
    unsigned char  reserv3[16];           /* reserved                     */
    AP_UINT32      num_users;             /* number of users in list      */
    unsigned char  reserv2[16];           /* reserved                     */
    } SECURITY_LIST_DEF;
```

```
typedef struct security_user_data
{
    AP_UINT16      sub_overlay_size;       /* reserved                     */
    unsigned char  user_name[10];         /* user name                    */
    } SECURITY_USER_DATA;
```

## Supplied parameters

The application supplies the following parameters:

### **opcode**

AP\_QUERY\_SECURITY\_ACCESS\_LIST

### **buf\_ptr**

A pointer to a data buffer that CS/AIX will use to return the requested information.

### ***buf\_size***

Size of the supplied data buffer.

### ***num\_entries***

Maximum number of security access lists for which data should be returned. This number includes partial security access list entries (for which a user name is specified, so that the returned data does not include the first user name in the list).

To request data for a specific security access list rather than a range, specify the value 1. To return as many entries as possible, specify zero; in this case, CS/AIX will return the maximum number of entries that can be accommodated in the supplied data buffer.

### ***list\_options***

The position in the list from which CS/AIX should begin to return data. Specify one of the following values:

#### **AP\_FIRST\_IN\_LIST**

Start at the first user name for the first security access list.

#### **AP\_LIST\_INCLUSIVE**

Start at the entry specified by the supplied security access list name and user name, or start at the first user name for the specified security access list if no user name is specified.

#### **AP\_LIST\_FROM\_NEXT**

If a user name is specified, start at the user immediately following the specified user. If no user name is specified, start at the first user for the specified security access list.

The list is ordered by security access list name, and then by user name within each security access list. For more information about how the list is ordered and how the application can obtain specific entries from it, see [“List options for QUERY\\_\\* Verbs” on page 33](#).

### ***list\_name***

The name of the security access list for which information is required, or the name to be used as an index into the list of security access lists. This parameter is ignored if *list\_options* is set to AP\_FIRST\_IN\_LIST. The name is an ASCII string of 1-14 characters, padded on the right with spaces if the name is shorter than 14 characters.

### ***user\_name***

To return information starting with a specific user name for the specified security access list, set this parameter to the user name. To return information starting at the first user name for the specified security access list, set this parameter to 10 binary zeros.

## Returned parameters: successful execution

If the verb executes successfully, CS/AIX returns the following parameters:

### ***primary\_rc***

AP\_OK

### ***buf\_size***

Length of the information returned in the buffer.

### ***total\_buf\_size***

Returned value indicating the size of buffer that would have been required to return all the list information requested. This may be higher than *buf\_size*.

### ***total\_num\_entries***

Total number of entries that could have been returned. This may be higher than *num\_entries*.

### ***num\_entries***

The number of entries actually returned. The last entry may be incomplete; this is indicated by the *last\_list\_incomplete* parameter.

### ***num\_init\_users***

If the *user\_name* parameter was set to a nonzero value, so that the information for the first security access list in the returned data does not start with the first user in that list, this parameter indicates

the number of user name structures for this list that are included in the returned data. Otherwise, this parameter is not used.

***num\_last\_users***

If the *last\_list\_incomplete* parameter indicates that the data for the last list is incomplete, this parameter indicates the number of user name structures for this list that are included in the returned data. (The *num\_filtered\_users* parameter returned for this list indicates the total number of user name structures that are available.) Otherwise, this parameter is not used.

***last\_list\_incomplete***

Specifies whether the information for the last security access list is incomplete. Possible values are:

**AP\_YES**

The complete data for the last security access list was too large to fit in the data buffer. At least one user name structure is included, but there are further user name structures that are not included in the data buffer. The *num\_last\_users* parameter indicates how many user name structures have been returned; the application can issue further verbs to obtain the remaining data.

**AP\_NO**

The data for the last list is complete.

Each entry in the data buffer consists of the following:

***security\_access\_detail.list\_name***

The name of the security access list. This is an ASCII string of 1-14 characters.

***security\_access\_detail.num\_filtered\_users***

The total number of user names in this security access list.

***security\_access\_detail.def\_data.description***

A null-terminated text string describing the security access list, as specified in the definition of the list.

***security\_access\_detail.def\_data.num\_users***

The total number of users in the security access list.

If this is the last list in the data buffer, and the *last\_list\_incomplete* parameter is set to AP\_YES, the total number of user name structures returned for this list will be as specified by the *num\_last\_users* parameter; this will be less than *num\_users*.

For each user name in the list, a *security\_user\_data* structure is returned with the following information:

***user\_name***

Name of the user.

This can be either of the following:

- An AIX login ID defined on the CS/AIX computer (if password substitution is disabled for LUs that use this security access list)
- A user ID defined using the DEFINE\_USERID\_PASSWORD verb

## Returned parameters: parameter check

If the verb does not execute because of a parameter error, CS/AIX returns the following parameters:

***primary\_rc***

AP\_PARAMETER\_CHECK

***secondary\_rc***

Possible values are:

**AP\_INVALID\_LIST\_NAME**

The *list\_options* parameter was set to AP\_LIST\_INCLUSIVE, but the *list\_name* parameter did not match the name of any defined security access list.

## QUERY\_SESSION

### AP\_INVALID\_USER\_NAME

The *list\_options* parameter was set to AP\_LIST\_INCLUSIVE, but the *user\_name* parameter did not match a user name defined for the specified security access list.

### AP\_INVALID\_LIST\_OPTION

The *list\_options* parameter was not set to a valid value.

Appendix B, “Common return codes,” on page 661 lists further secondary return codes associated with AP\_PARAMETER\_CHECK, which are common to all NOF verbs.

## Returned parameters: other conditions

Appendix B, “Common return codes,” on page 661 lists further combinations of primary and secondary return codes that are common to all NOF verbs.

## QUERY\_SESSION

QUERY\_SESSION returns list information about sessions for a particular local LU.

This verb can be used to obtain either summary or detailed information, about a specific session or a range of sessions, depending on the options used.

This verb must be issued to a running node.

## VCB structure

```
typedef struct query_session
{
    AP_UINT16      opcode;                /* verb operation code          */
    unsigned char  reserv2;               /* reserved                     */
    unsigned char  format;                /* reserved                     */
    AP_UINT16      primary_rc;            /* primary return code          */
    AP_UINT32      secondary_rc;          /* secondary return code        */
    unsigned char  *buf_ptr;              /* pointer to buffer            */
    AP_UINT32      buf_size;               /* buffer size                  */
    AP_UINT32      total_buf_size;        /* total buffer size required   */
    AP_UINT16      num_entries;            /* number of entries            */
    AP_UINT16      total_num_entries;     /* total number of entries      */
    unsigned char  list_options;          /* listing options              */
    unsigned char  reserv3;               /* reserved                     */
    unsigned char  lu_name[8];            /* LU name                      */
    unsigned char  lu_alias[8];           /* LU alias                     */
    unsigned char  plu_alias[8];          /* partner LU alias             */
    unsigned char  fqplu_name[17];        /* fully qualified partner LU name */
    unsigned char  mode_name[8];          /* mode name                    */
    unsigned char  session_id[8];         /* session ID                   */
} QUERY_SESSION;
```

```
typedef struct session_summary
{
    AP_UINT16      overlay_size;           /* size of returned entry       */
    unsigned char  plu_alias[8];           /* partner LU alias             */
    unsigned char  fqplu_name[17];        /* fully qualified partner LU name */
    unsigned char  reserv3[1];            /* reserved                     */
    unsigned char  mode_name[8];          /* mode name                    */
    unsigned char  session_id[8];         /* session ID                   */
    FQPCID         fqpcid;                /* fully qualified procedure     */
    unsigned char  correlator_id;         /* correlator ID                */
} SESSION_SUMMARY;
```

```
typedef struct session_detail
{
    AP_UINT16      overlay_size;           /* size of returned entry       */
    unsigned char  plu_alias[8];           /* partner LU alias             */
    unsigned char  fqplu_name[17];        /* fully qualified partner LU name */
    unsigned char  reserv3[1];            /* reserved                     */
    unsigned char  mode_name[8];          /* mode name                    */
    unsigned char  session_id[8];         /* session ID                   */
    FQPCID         fqpcid;                /* fully qualified procedure     */
    unsigned char  correlator_id;         /* correlator ID                */
    unsigned char  cos_name[8];           /* Class of Service name        */
}
```



```

unsigned char  trans_pri;          /* Transmission priority:          */
unsigned char  ltd_res;           /* Session spans a limited resource */
unsigned char  polarity;         /* Session polarity                */
unsigned char  contention;       /* Session contention               */
SESSION_STATS sess_stats;       /* Session statistics              */
unsigned char  reserv3a;        /* reserved                        */
unsigned char  sscp_id[6];      /* SSCP ID of host                 */
unsigned char  reserva;         /* reserved                        */
AP_UINT32     session_start_time; /* start time of the session      */
AP_UINT16     session_timeout;  /* session timeout                 */
unsigned char  cryptography;    /* reserved                        */
unsigned char  reservb[5];      /* reserved                        */
unsigned char  comp_in_series;   /* reserved                        */
unsigned char  plu_slu_comp_lvl; /* PLU to SLU compression level   */
unsigned char  slu_plu_comp_lvl; /* SLU to PLU compression level   */
unsigned char  rscv_len;        /* Length of following RSCV       */
} SESSION_DETAIL;

```

The session detail structure may be followed by a Route Selection Control Vector (RSCV) as defined by SNA Formats. This control vector defines the session route through the network and is carried on the BIND. This RSCV is included only if the node's configuration (specified using DEFINE\_NODE) indicates that endpoint RSCVs should be stored.

```

typedef struct fqpcid
{
    unsigned char  pcid[8];          /* procedure correlator identifier */
    unsigned char  fqcp_name[17];   /* originator's network qualified */
                                   /* CP name                         */
    unsigned char  reserve3[3];     /* reserved                        */
} FQPCID;

```

```

typedef struct session_stats
{
    AP_UINT16     rcv_ru_size;      /* session receive RU size        */
    AP_UINT16     send_ru_size;     /* session send RU size           */
    AP_UINT16     max_send_btu_size; /* Maximum send BTU size         */
    AP_UINT16     max_rcv_btu_size; /* Maximum rcv BTU size          */
    AP_UINT16     max_send_pac_win; /* Maximum send pacing window size */
    AP_UINT16     cur_send_pac_win; /* Current send pacing window size */
    AP_UINT16     max_rcv_pac_win;  /* Maximum receive pacing window */
                                   /* size                           */
    AP_UINT16     cur_rcv_pac_win;  /* Current receive pacing window */
                                   /* size                           */
    AP_UINT32     send_data_frames; /* Number of data frames sent     */
    AP_UINT32     send_fmd_data_frames; /* Num fmd data frames sent     */
    AP_UINT32     send_data_bytes;  /* Number of data bytes sent      */
    AP_UINT32     rcv_data_frames;  /* Number of data frames received */
    AP_UINT32     rcv_fmd_data_frames; /* Num fmd data frames received */
    AP_UINT32     rcv_data_bytes;   /* Number of data bytes received  */
    unsigned char  sidh;            /* Session ID high byte (from LFSID) */
    unsigned char  sidl;            /* Session ID low byte (from LFSID) */
    unsigned char  odai;            /* ODAI bit set                   */
    unsigned char  ls_name[8];      /* Link station name (or RTP name) */
    unsigned char  pacing_type;     /* type of pacing in use          */
} SESSION_STATS;

```

## Supplied parameters

The application supplies the following parameters:

### ***opcode***

AP\_QUERY\_SESSION

### ***buf\_ptr***

A pointer to a data buffer that CS/AIX will use to return the requested information.

### ***buf\_size***

Size of the supplied data buffer.

### ***num\_entries***

Maximum number of sessions for which data should be returned. To request data for a specific session rather than a range, specify the value 1. To return as many entries as possible, specify zero; in

this case, CS/AIX will return the maximum number of entries that can be accommodated in the supplied data buffer.

***list\_options***

The position in the list from which CS/AIX should begin to return data, and the level of information required for each entry. Specify the level of information with one of the following values:

**AP\_SUMMARY**

Summary information only.

**AP\_DETAIL**

Detailed information.

Combine this value using a logical OR operation with one of the following values:

**AP\_FIRST\_IN\_LIST**

Start at the first entry in the list.

**AP\_LIST\_INCLUSIVE**

Start at the entry specified by the *session\_id* parameter.

**AP\_LIST\_FROM\_NEXT**

Start at the entry immediately following the entry specified by the *session\_id* parameter.

The combination of the local LU (*lu\_name* or *lu\_alias*), partner LU (*plu\_alias* or *fqplu\_name*), and *mode\_name* specified is used as an index into the list of sessions if the *list\_options* parameter is set to AP\_LIST\_INCLUSIVE or AP\_LIST\_FROM\_NEXT.

For more information about how the list is ordered and how the application can obtain specific entries from it, see [“List options for QUERY\\_\\* Verbs”](#) on page 33.

***lu\_name***

LU name. This is an 8-byte type-A EBCDIC string, padded on the right with spaces if the name is shorter than 8 characters. To specify that the LU is identified by its alias rather than its LU name, set this parameter to 8 binary zeros and specify the LU alias in the following parameter. To specify the LU associated with the local CP (the default LU), set both *lu\_name* and *lu\_alias* to binary zeros.

***lu\_alias***

Locally defined LU alias. This is an 8-byte ASCII string, padded on the right with spaces if the name is shorter than 8 bytes. This parameter is used only if *lu\_name* is set to 8 binary zeros; it is ignored otherwise. To specify the LU associated with the local CP (the default LU), set both *lu\_name* and *lu\_alias* to binary zeros.

***plu\_alias***

Partner LU alias. To return information only about sessions associated with a specific partner LU, specify the partner LU alias (in this parameter) or the partner LU fully qualified name (in the following parameter). To return information about all sessions without filtering on the partner LU, set both of these parameters to binary zeros.

This is an 8-byte ASCII string, padded on the right with spaces if the name is shorter than 8 bytes. To specify that the LU is identified by its LU name rather than its alias, set this parameter to 8 binary zeros and specify the LU name in the following parameter.

***fqplu\_name***

Fully qualified network name for the partner LU. This parameter is used only if *plu\_alias* is set to 8 binary zeros; it is ignored otherwise.

The name is a 17-byte EBCDIC string, right-padded with EBCDIC spaces. It consists of a network ID of up to 8 A-string characters, an EBCDIC dot (period) character, and a network name of up to 8 A-string characters.

***mode\_name***

Mode name filter. To return information only about sessions associated with a specific mode, specify the mode name; the partner LU must also be specified (using one of the two preceding parameters). To return information about all sessions without filtering on mode name, set this parameter to 8 binary zeros.

The mode name is an 8-byte type-A EBCDIC string, padded on the right with spaces if the name is shorter than 8 characters.

***session\_id***

8-byte identifier of the session. This parameter is ignored if *list\_options* is set to AP\_FIRST\_IN\_LIST.

## Returned parameters: successful execution

If the verb executes successfully, CS/AIX returns the following parameters:

***primary\_rc***

AP\_OK

***buf\_size***

Length of the information returned in the supplied buffer.

***total\_buf\_size***

Returned value indicating the size of buffer that would have been required to return all the list information requested. A value greater than *buf\_size* indicates that not all the available entries were returned.

***num\_entries***

Number of entries returned in the data buffer.

***total\_num\_entries***

Total number of entries available. A value greater than *num\_entries* indicates that not all the available entries were returned.

Each entry in the data buffer consists of the following parameters:

***session\_summary.overlay\_size***

The size of the returned *session\_summary* structure, and therefore the offset to the start of the next entry in the data buffer.

When your application needs to go through the returned buffer to find each *session\_summary* structure in turn, it must use this value to move to the correct offset for the next data structure, and must not use the C `sizeof()` operator. This is because the size of the returned overlay may increase in future releases of CS/AIX; using the returned overlay size ensures that your application will continue to work with future releases.

***session\_summary.plu\_alias***

Partner LU alias. This is an 8-byte ASCII character string, right-padded with ASCII spaces.

***session\_summary.fqplu\_name***

Fully qualified network name for the partner LU. The name is a 17-byte EBCDIC string, right-padded with EBCDIC spaces. It consists of a network ID of up to 8 A-string characters, an EBCDIC dot (period) character, and a network name of up to 8 A-string characters.

***session\_summary.mode\_name***

Mode name. This is an 8-byte type-A EBCDIC string (starting with a letter), right-padded with EBCDIC spaces.

***session\_summary.session\_id***

8-byte identifier of the session.

***session\_summary.fqpcid.pcid***

Procedure Correlator ID. This is an 8-byte hexadecimal string.

***session\_summary.fqpcid.fqcp\_name***

Fully qualified CP name. The name is a 17-byte EBCDIC string, right-padded with EBCDIC spaces. It consists of a network ID of up to 8 A-string characters, an EBCDIC dot (period) character, and a network name of up to 8 A-string characters.

***session\_detail.overlay\_size***

The size of the returned *session\_detail* structure, and therefore the offset to the start of the next entry in the data buffer.

When your application needs to go through the returned buffer to find each `session_detail` structure in turn, it must use this value to move to the correct offset for the next data structure, and must not use the C `sizeof()` operator. This is because the size of the returned overlay may increase in future releases of CS/AIX; using the returned overlay size ensures that your application will continue to work with future releases.

### ***session\_detail.plu\_alias***

Partner LU alias. This is an 8-byte ASCII character string, right-padded with ASCII spaces.

### ***session\_detail.fqplu\_name***

Fully qualified network name for the partner LU. The name is a 17-byte EBCDIC string, right-padded with EBCDIC spaces. It consists of a network ID of up to 8 A-string characters, an EBCDIC dot (period) character, and a network name of up to 8 A-string characters.

### ***session\_detail.mode\_name***

Mode name. This is an 8-byte type-A EBCDIC string (starting with a letter), right-padded with EBCDIC spaces.

### ***session\_detail.session\_id***

8-byte identifier of the session.

### ***session\_detail.fqpcid.pcid***

Procedure Correlator ID. This is an 8-byte hexadecimal string.

### ***session\_detail.fqpcid.fqcp\_name***

Fully qualified control point name. This is a 17-byte EBCDIC string, padded on the right with EBCDIC spaces. It consists of a network ID of 1-8 A-string characters, an EBCDIC dot (period) character, and a network name of 1-8 A-string characters.

### ***session\_detail.cos\_name***

Class of service name. This is an 8-byte type-A EBCDIC string, padded on the right with spaces if the name is shorter than 8 characters.

### ***session\_detail.trans\_pri***

Transmission priority. Possible values are:

AP\_LOW

AP\_MEDIUM

AP\_HIGH

AP\_NETWORK

### ***session\_detail.ltd\_res***

Specifies whether the session uses a limited resource link. Possible values are:

**AP\_YES**

Session uses a limited resource link.

**AP\_NO**

Session does not use a limited resource link.

### ***session\_detail.polarity***

Specifies the polarity of the session. Possible values are:

AP\_PRIMARY

AP\_SECONDARY

### ***session\_detail.contention***

Specifies whether the session is a contention winner or contention loser session for the local LU. Possible values are:

**AP\_CONWINNER**

Contention winner session

**AP\_CONLOSER**

Contention loser session

***session\_detail.sess\_stats.rcv\_ru\_size***

Maximum receive RU size.

***session\_detail.sess\_stats.send\_ru\_size***

Maximum send RU size.

***session\_detail.sess\_stats.max\_send\_btu\_size***

Maximum BTU size that can be sent.

***session\_detail.sess\_stats.max\_rcv\_btu\_size***

Maximum BTU size that can be received.

***session\_detail.sess\_stats.max\_send\_pac\_win***

Maximum size of the send pacing window on this session.

***session\_detail.sess\_stats.cur\_send\_pac\_win***

Current size of the send pacing window on this session.

***session\_detail.sess\_stats.max\_rcv\_pac\_win***

Maximum size of the receive pacing window on this session.

***session\_detail.sess\_stats.cur\_rcv\_pac\_win***

Current size of the receive pacing window on this session.

***session\_detail.sess\_stats.send\_data\_frames***

Number of normal flow data frames sent.

***session\_detail.sess\_stats.send\_fmd\_data\_frames***

Number of normal flow FMD data frames sent.

***session\_detail.sess\_stats.send\_data\_bytes***

Number of normal flow data bytes sent.

***session\_detail.sess\_stats.rcv\_data\_frames***

Number of normal flow data frames received.

***session\_detail.sess\_stats.rcv\_fmd\_data\_frames***

Number of normal flow FMD data frames received.

***session\_detail.sess\_stats.rcv\_data\_bytes***

Number of normal flow data bytes received.

***session\_detail.sess\_stats.sidh***

Session ID high byte.

***session\_detail.sess\_stats.sidl***

Session ID low byte.

***session\_detail.sess\_stats.odai***

Origin Destination Assignor Indicator. When bringing up a session, the sender of the BIND sets this field to zero if the local node contains the primary link station. It sets it to one if the BIND sender is the node containing the secondary link station.

***session\_detail.sess\_stats.ls\_name***

Link station name associated with statistics. This is an 8-byte ASCII string, padded on the right with spaces if the name is shorter than 8 bytes. This field can be used to correlate the session statistics with the link over which session data flows.

***session\_detail.sess\_stats.pacing\_type***

The type of receive pacing in use on this session. Possible values are:

- AP\_NONE
- AP\_FIXED
- AP\_ADAPTIVE

***session\_detail.duplex\_support***

Returns the conversation duplex support as negotiated on the BIND. Possible values are:

**AP\_HALF-DUPLEX**

Only half-duplex conversations are supported.

## QUERY\_SESSION

### **AP\_FULL\_DUPLEX**

Both full-duplex and half-duplex sessions are supported. Expedited data is also supported.

### ***session\_detail.sscp\_id***

For dependent LU sessions, this parameter is the SSCP ID received in the ACTPU from the host for the PU to which the local LU is mapped. For independent LU sessions, this parameter is set to 0 (zero).

### ***session\_detail.session\_start\_time***

The time between the CP starting and this session becoming active, measured in one-hundredths of a second. If the session is not fully active when the query is processed, this parameter is set to 0 (zero).

### ***session\_detail.session\_timeout***

The timeout associated with this session This timeout is derived from:

- The LU 6.2 timeout associated with the local LU
- The LU 6.2 timeout associated with the remote LU
- The mode timeout
- The global timeout
- The limited resource timeout (if this session is running over a limited resource link)

### ***session\_detail.plu\_slu\_comp\_lvl***

Specifies the compression level for data sent from the primary LU (PLU) to the secondary LU (SLU). Possible values are:

#### **AP\_NONE**

Compression is not used.

#### **AP\_RLE\_COMPRESSION**

Run-length encoding (RLE) compression is used.

#### **AP\_LZ9\_COMPRESSION**

LZ9 compression is used.

#### **AP\_LZ10\_COMPRESSION**

LZ10 compression is used.

### ***session\_detail.slu\_plu\_comp\_lvl***

Specifies the compression level for data sent from the secondary LU (SLU) to the primary LU (PLU). Possible values are:

#### **AP\_NONE**

Compression is not used.

#### **AP\_RLE\_COMPRESSION**

Run-length encoding (RLE) compression is used.

#### **AP\_LZ9\_COMPRESSION**

LZ9 compression is used.

#### **AP\_LZ10\_COMPRESSION**

LZ10 compression is used.

### ***session\_detail.rscv\_len***

Length of the RSCV which is appended to the `session_detail` structure. (If none is appended, then the length is zero.)

## Returned parameters: parameter check

If the verb does not execute because of a parameter error, CS/AIX returns the following parameters:

### ***primary\_rc***

AP\_PARAMETER\_CHECK

### ***secondary\_rc***

Possible values are:

**AP\_INVALID\_LU\_ALIAS**

The specified *lu\_alias* parameter was not valid.

**AP\_INVALID\_LU\_NAME**

The specified *lu\_name* parameter was not valid.

**AP\_INVALID\_SESSION\_ID**

The *list\_options* parameter was set to AP\_LIST\_INCLUSIVE to list all entries starting from the supplied value, but the *session\_id* parameter was not valid.

**AP\_INVALID\_LIST\_OPTION**

The *list\_options* parameter was not set to a valid value.

Appendix B, “Common return codes,” on page 661 lists further secondary return codes associated with AP\_PARAMETER\_CHECK, which are common to all NOF verbs.

## Returned parameters: other conditions

Appendix B, “Common return codes,” on page 661 lists further combinations of primary and secondary return codes that are common to all NOF verbs.

## QUERY\_SNA\_NET

QUERY\_SNA\_NET returns information about servers that can act as backup servers, as defined in the `sna.net` file. It can be used to obtain information about a specific server or about multiple servers, depending on the options used.

The ordering of server names in this file is significant; the first server listed in the file will always be the controller if it is active, the second will be the controller if the first is inactive, the third will be the controller if the first and second are both inactive, and so on. Because of this, the list of server names returned on QUERY\_SNA\_NET is in the same order as it is in the file; the returned names are not ordered by name length and lexicographical ordering, as with other QUERY\_\* verbs.

This verb must be issued to the `sna.net` file.

## VCB structure

```
typedef struct query_sna_net
{
    AP_UINT16      opcode;                /* Verb operation code          */
    unsigned char  reserv2;               /* reserved                     */
    unsigned char  format;                /* reserved                     */
    AP_UINT16      primary_rc;            /* Primary return code          */
    AP_UINT32      secondary_rc;          /* Secondary return code        */
    unsigned char  *buf_ptr;              /* pointer to buffer            */
    AP_UINT32      buf_size;              /* buffer size                  */
    AP_UINT32      total_buf_size;        /* total buffer size required   */
    AP_UINT16      num_entries;            /* number of entries            */
    AP_UINT16      total_num_entries;     /* total number of entries      */
    unsigned char  list_options;          /* listing options              */
    unsigned char  security;              /* reserved                     */
    unsigned char  domain_name[64];       /* domain name                  */
    unsigned char  server_name[128];      /* controller or backup server name */
    unsigned char  reserv4[4];            /* reserved                     */
} QUERY_SNA_NET;
```

```
typedef struct backup_summary
{
    AP_UINT16      overlay_size;           /* size of returned entry       */
    unsigned char  reserv1[2];            /* reserved                     */
    unsigned char  server_name[128];      /* controller or backup server name */
    unsigned char  reserv2[4];            /* reserved                     */
} BACKUP_SUMMARY;
```

## Supplied parameters

The application supplies the following parameters:

***opcode***

AP\_QUERY\_SNA\_NET

***buf\_ptr***

A pointer to a data buffer that CS/AIX will use to return the requested information.

***buf\_size***

Size of the supplied data buffer.

***num\_entries***

Maximum number of server names for which data should be returned. To request a specific entry rather than a range, specify the value 1. To return as many entries as possible, specify zero; in this case, CS/AIX will return the maximum number of entries that can be accommodated in the supplied data buffer.

***list\_options***

The position in the list from which CS/AIX should begin to return data.

Specify one of the following values:

**AP\_FIRST\_IN\_LIST**

Start at the first entry in the list.

**AP\_LIST\_INCLUSIVE**

Start at the entry specified by the *server\_name* parameter.

**AP\_LIST\_FROM\_NEXT**

Start at the entry immediately following the entry specified by the *server\_name* parameter.

For more information about how the application can obtain specific entries from the list, see [“List options for QUERY\\_\\* Verbs”](#) on page 33. The server names are listed in the same order as in the file, not in order of name length and/or lexicographical order as for other QUERY\_\* verbs.

***server\_name***

Name of the server for which information is required, or the name to be used as an index into the list of servers. The server name is ignored if *list\_options* is set to AP\_FIRST\_IN\_LIST.

If the server name includes a . (period) character, CS/AIX assumes that it is a fully-qualified name; otherwise it performs a DNS lookup to determine the server name.

## Returned parameters: successful execution

If the verb executes successfully, CS/AIX returns the following parameters:

***primary\_rc***

AP\_OK

***buf\_size***

Length of the information returned in the supplied buffer.

***total\_buf\_size***

Returned value indicating the size of buffer that would have been required to return all the list information requested. A value greater than *buf\_size* indicates that not all the available entries were returned.

***num\_entries***

Number of entries returned in the data buffer.

***total\_num\_entries***

Total number of entries available. A value greater than *num\_entries* indicates that not all the available entries were returned.

***domain\_name***

The name of the TCP/IP domain containing the CS/AIX LAN. This name was specified during installation of the controller server.

Each entry in the data buffer consists of the following parameters:



***backup\_summary.overlay\_size***

The size of the returned `backup_summary` structure, and therefore the offset to the start of the next entry in the data buffer.

When your application needs to go through the returned buffer to find each `backup_summary` structure in turn, it must use this value to move to the correct offset for the next data structure, and must not use the C `sizeof()` operator. This is because the size of the returned overlay may increase in future releases of CS/AIX; using the returned overlay size ensures that your application will continue to work with future releases.

***backup\_summary.server\_name***

Server name.

**Returned parameters: parameter check**

If the verb does not execute because of a parameter error, CS/AIX returns the following parameters:

***primary\_rc***

AP\_PARAMETER\_CHECK

***secondary\_rc*****AP\_INVALID\_LIST\_OPTION**

The *list\_options* parameter was not set to a valid value.

Appendix B, “Common return codes,” on page 661 lists further secondary return codes associated with AP\_PARAMETER\_CHECK, which are common to all NOF verbs.

**Returned parameters: state check**

If the verb does not execute because of a state check, CS/AIX returns the following parameters.

***primary\_rc***

AP\_STATE\_CHECK

***secondary\_rc***

Possible values are:

**AP\_RECORD\_NOT\_FOUND**

The *list\_options* parameter was set to AP\_LIST\_INCLUSIVE or AP\_LIST\_FROM\_NEXT to list entries starting from the supplied server name, but the *backup\_name* parameter did not match an entry in the file. If the supplied name was one returned on a previous QUERY\_SNA\_NET verb, this indicates that the list has been updated (by another administration program or NOF application) since the previous verb; the application should reissue QUERY\_SNA\_NET to obtain the complete list.

**AP\_INVALID\_TARGET**

The target handle on the NOF API call specified a configuration file or a node. This verb must be issued to the `sna.net` file.

Appendix B, “Common return codes,” on page 661 lists further secondary return codes associated with AP\_STATE\_CHECK, which are common to all NOF verbs.

**Returned parameters: other conditions**

Appendix B, “Common return codes,” on page 661 lists further combinations of primary and secondary return codes that are common to all NOF verbs.

**QUERY\_STATISTICS**

QUERY\_STATISTICS returns statistics on the usage of an LS. The Enterprise Extender (HPR/IP) link type does not support link statistics; do not issue this verb for an Enterprise Extender LS or port.

This verb must be issued to a running node.

## VCB structure

```
typedef struct query_statistics
{
    AP_UINT16      opcode;           /* verb operation code          */
    unsigned char  reserv2;         /* reserved                     */
    unsigned char  format;         /* reserved                     */
    AP_UINT16      primary_rc;     /* primary return code         */
    AP_UINT32      secondary_rc;   /* secondary return code       */
    unsigned char  name[8];        /* LS name or port name        */
    unsigned char  stats_type;     /* LS or port statistics?     */
    unsigned char  table_type;     /* statistics table requested  */
    unsigned char  reset_stats;    /* reset the statistics?      */
    unsigned char  dlc_type;       /* type of DLC                 */
    unsigned char  statistics[256]; /* current statistics          */
    unsigned char  reserva[20];    /* reserved                    */
} QUERY_STATISTICS;
```

LS statistics:

```
typedef struct vdl_ls_statistics
{
    V0_MUX_INFO    mux_info;        /* streams config info         */
    AP_UINT32      ls_st_mus_sent;  /* Frames sent from this Link Stn */
    AP_UINT32      ls_st_mus_received; /* Frames received at this Link Stn */
    AP_UINT32      ls_st_bytes_sent; /* Bytes sent from this Link Stn */
    AP_UINT32      ls_st_bytes_received; /* Bytes received at this Link Stn */
    AP_UINT32      ls_st_test_cmds_sent; /* test commands sent         */
    AP_UINT32      ls_st_test_cmds_rec; /* test commands received     */
    AP_UINT32      ls_st_data_pkt_reseat; /* sequenced data packets reseat */
    AP_UINT32      ls_st_inv_pkt_rec; /* invalid packets received   */
    AP_UINT32      ls_st_adp_rec_err; /* data detected receive errors */
    AP_UINT32      ls_st_adp_send_err; /* data detected transmit errors */
    AP_UINT32      ls_st_rec_inact_to; /* received inactivity timeouts */
    AP_UINT32      ls_st_cmd_polls_sent; /* command polls sent         */
    AP_UINT32      ls_st_cmd_repolls_sent; /* command repolls sent      */
    AP_UINT32      ls_st_cmd_cont_repolls; /* max continuous repolls sent */
} VDL_LS_STATISTICS;
```

```
typedef struct v0_mux_info
{
    AP_UINT16      dlc_type;        /* DLC implementation type     */
    unsigned char  need_vrfy_fixup; /* reserved                   */
    unsigned char  num_mux_ids;    /* reserved                   */
    AP_UINT32      card_type;      /* type of adapter card       */
    AP_UINT32      adapter_number; /* DLC adapter number         */
    AP_UINT32      oem_data_length; /* reserved                   */
    AP_UINT32      mux_ids[5];    /* reserved                   */
} V0_MUX_INFO;
```

## Supplied parameters

The application supplies the following parameters:

### **opcode**

AP\_QUERY\_STATISTICS

### **name**

Name of the LS for which statistics are required. This is an 8-byte ASCII string, padded on the right with spaces if the name is shorter than 8 bytes. CS/AIX uses this name to correlate the response to the correct link station.

### **stats\_type**

The type of resource for which statistics are requested. Set this to AP\_LS.

### **table\_type**

The type of statistics information requested. Set this to AP\_STATS\_TBL.

### **reset\_stats**

Specifies whether to reset the statistics when this verb completes. Possible values are:

**AP\_YES**

Reset the statistics; a subsequent QUERY\_STATISTICS verb will contain only data gathered after this verb was issued.

**AP\_NO**

Do not reset the statistics; the data on this verb will be included in the data returned to a subsequent QUERY\_STATISTICS verb.

***dlc\_type***

Type of the DLC. Possible values are:

**AP\_SDLC**

Synchronous data link control

**AP\_TR**

Token Ring

**AP\_ETHERNET**

Ethernet

**AP\_X25**

X.25 packet switching

## Returned parameters: successful execution

If the verb executes successfully, CS/AIX returns the following parameters:

***primary\_rc***

AP\_OK

***dlc\_type***

Type of DLC for which statistics information is being returned. Possible values are:

**AP\_SDLC**

SDLC

**AP\_X25**

QLLC

**AP\_TR**

Token Ring

**AP\_ETHERNET**

Ethernet

***statistics***

Current statistics for the link station. This string is replaced by the appropriate structure for the DLC type. The parameters in the structure are described below.

***mux\_info.dlc\_type, mux\_info.card\_type, mux\_info.adapter\_number***

Streams configuration information for the DLC. For more information about these parameters, see [“DEFINE\\_DLC”](#) on page 74.

***vdl\_ls\_statistics.ls\_st\_mus\_sent***

Number of frames sent from CS/AIX on this LS since the LS was started.

***vdl\_ls\_statistics.ls\_st\_mus\_received***

Number of frames received by CS/AIX on this LS since the LS was started.

***vdl\_ls\_statistics.ls\_st\_bytes\_sent***

Number of bytes sent from CS/AIX on this LS since the LS was started.

***vdl\_ls\_statistics.ls\_st\_bytes\_received***

Number of bytes received by CS/AIX on this LS since the LS was started.

***vdl\_ls\_statistics.ls\_st\_test\_cmds\_sent***

Number of TEST commands sent by CS/AIX on this LS since the LS was started.

***vdl\_ls\_statistics.ls\_st\_test\_cmds\_rec***

Number of TEST commands received by CS/AIX on this LS since the LS was started.

## QUERY\_STATISTICS

### ***vdl\_ls\_statistics.ls\_st\_data\_pkt\_resent***

Number of sequenced data packets resent by CS/AIX on this LS since the LS was started.

### ***vdl\_ls\_statistics.ls\_st\_inv\_pkt\_rec***

Number of invalid packets received by CS/AIX on this LS since the LS was started.

### ***vdl\_ls\_statistics.ls\_st\_adp\_rec\_err***

Number of data detected receive errors on this LS since the LS was started.

### ***vdl\_ls\_statistics.ls\_st\_adp\_send\_err***

Number of data detected transmit errors on this LS since the LS was started.

### ***vdl\_ls\_statistics.ls\_st\_rec\_inact\_to***

Number of received inactivity timeouts on this LS since the LS was started.

### ***vdl\_ls\_statistics.ls\_st\_cmd\_polls\_sent***

Number of command polls sent by CS/AIX on this LS since the LS was started.

### ***vdl\_ls\_statistics.ls\_st\_cmd\_repolls\_sent***

Number of command repolls sent by CS/AIX on this LS since the LS was started.

### ***vdl\_ls\_statistics.ls\_st\_cmd\_cont\_repolls***

Maximum number of continuous repolls sent by CS/AIX on this LS since the LS was started.

## Returned parameters: parameter check

If the verb does not execute because of a parameter error, CS/AIX returns the following parameters:

### ***primary\_rc***

AP\_PARAMETER\_CHECK

### ***secondary\_rc***

Possible values are:

#### **AP\_INVALID\_LINK\_NAME**

The supplied name parameter was not a valid LS name.

#### **AP\_INVALID\_STATS\_TYPE**

The *stats\_type* parameter was not set to a valid value.

#### **AP\_INVALID\_TABLE\_TYPE**

The *table\_type* parameter was not set to a valid value.

Appendix B, "Common return codes," on page 661 lists further secondary return codes associated with AP\_PARAMETER\_CHECK, which are common to all NOF verbs.

## Returned parameters: state check

If the verb does not execute because of a state error, CS/AIX returns the following parameters.

### ***primary\_rc***

AP\_STATE\_CHECK

### ***secondary\_rc***

Possible values are:

#### **AP\_LINK\_DEACTIVATED**

The specified link is not currently active.

#### **AP\_PORT\_DEACTIVATED**

The specified port is not currently active.

Appendix B, "Common return codes," on page 661 lists further secondary return codes associated with AP\_STATE\_CHECK, which are common to all NOF verbs.

## Returned parameters: function not supported

If the verb does not execute because the DLC type does not support returning statistics information, CS/AIX returns the following parameter:

**primary\_rc**

AP\_FUNCTION\_NOT\_SUPPORTED

**Returned parameters: other conditions**

Appendix B, “Common return codes,” on page 661 lists further combinations of primary and secondary return codes that are common to all NOF verbs.

**QUERY\_TN3270\_ACCESS\_DEF**

QUERY\_TN3270\_ACCESS\_DEF returns information about TN3270 users on other computers that can use the TN server feature of CS/AIX to access a host for 3270 emulation using TN3270 Server. (To return information about users accessing the host using TN Redirector, use QUERY\_TN\_REDIRECT\_DEF.)

This verb can return either summary or detailed information, about a single user or multiple users, depending on the options used.

**VCB structure**

```
typedef struct query_tn3270_access_def
{
    AP_UINT16      opcode;                /* verb operation code          */
    unsigned char  reserv2;               /* reserved                     */
    unsigned char  format;                /* reserved                     */
    AP_UINT16      primary_rc;            /* primary return code          */
    AP_UINT32      secondary_rc;          /* secondary return code        */
    unsigned char  *buf_ptr;              /* pointer to buffer            */
    AP_UINT32      buf_size;              /* buffer size                  */
    AP_UINT32      total_buf_size;        /* total buffer size required    */
    AP_UINT16      num_entries;           /* number of entries            */
    AP_UINT16      total_num_entries;     /* total number of entries      */
    unsigned char  list_options;          /* listing options              */
    unsigned char  reserv3;               /* reserved                     */
    AP_UINT16      default_record;         /* start with DEFAULT record?   */
    unsigned char  client_address[256];    /* address of TN3270 user       */
    AP_UINT16      port_number;           /* TCP/IP port to access server */
    AP_UINT32      num_init_sessions;     /* number of sessions for first */
    AP_UINT32      num_last_sessions;     /* user when starting in middle */
    AP_UINT32      num_last_sessions;     /* number of sessions on last   */
    AP_UINT32      num_last_sessions;     /* detail overlay if last user  */
    AP_UINT32      num_last_sessions;     /* is incomplete                */
    unsigned char  last_user_incomplete;  /* set to AP_YES if session     */
    unsigned char  reserv4[11];           /* data for last user incomplete*/
    unsigned char  reserv4[11];           /* Reserved                      */
} QUERY_TN3270_ACCESS_DEF;
```

```
typedef struct tn3270_access_summary
{
    AP_UINT16      overlay_size;          /* overlay size                 */
    AP_UINT16      default_record;         /* is this the DEFAULT record?  */
    unsigned char  client_address[256];    /* address of TN3270 user       */
    AP_UINT16      address_format;        /* Format of client address      */
    unsigned char  reserv3[6];            /* Reserved                     */
} TN3270_ACCESS_SUMMARY;
```

```
typedef struct tn3270_access_detail
{
    AP_UINT16      overlay_size;          /* overlay size                 */
    AP_UINT16      sub_overlay_offset;    /* offset to first sess struct*/
    AP_UINT16      default_record;         /* is this the DEFAULT record?*/
    unsigned char  client_address[256];    /* address of TN3270 user       */
    AP_UINT32      num_filtered_sessions; /* num sess returned for user   */
    unsigned char  reserv3[4];            /* Reserved                     */
    TN3270_ACCESS_DEF_DATA def_data;      /* user definition              */
} TN3270_ACCESS_DETAIL;
```

```
typedef struct tn3270_access_def_data
{
    unsigned char  description[32];        /* Description - null terminated */
    unsigned char  reserv1[16];           /* reserved                     */
    AP_UINT16      address_format;        /* Format of client address      */
}
```

## QUERY\_TN3270\_ACCESS\_DEF

```
    AP_UINT32    num_sessions;          /* Number of sessions being added */
    unsigned char reserv3[64];         /* reserved */
} TN3270_ACCESS_DEF_DATA;
```

For each session, up to the number specified by the *num\_sessions* parameter, the following structure is included at the end of the *def\_data* structure:

```
typedef struct tn3270_session_def_data
{
    AP_UINT16    sub_overlay_size;      /* reserved */
    unsigned char description[32];      /* Session description */
    unsigned char tn3270_support;      /* Level of TN3270 support */
    unsigned char allow_specific_lu;   /* Allow access to specific LUs */
    unsigned char printer_lu_name[8];  /* Generic printer LU/pool
                                        /* accessed */
    unsigned char reserv1[6];          /* reserved */
    AP_UINT16    port_number;           /* TCP/IP port used to access
                                        /* server */
    unsigned char lu_name[8];          /* Generic display LU/pool
                                        /* accessed */
    unsigned char session_type;        /* Unused in current version */
    unsigned char model_override;      /* Unused in current version */
    unsigned char ssl_enabled;         /* Is this an SSL session? */
    unsigned char security_level;      /* SSL encryption strength */
    unsigned char cert_key_label[80];  /* Certificate key label */
    unsigned char listen_local_address[46];
                                        /* Local addr client connects to
                                        /* Allow non-SSL clients on SSL?
    unsigned char allow_ssl_timeout_to_nonssl;
    unsigned char reserv3[17];
    AP_UINT32    reserv4;               /* reserved */
} TN3270_SESSION_DEF_DATA;
```

## Supplied parameters

The application supplies the following parameters:

### ***opcode***

AP\_QUERY\_TN3270\_ACCESS\_DEF

### ***buf\_ptr***

A pointer to a data buffer that CS/AIX will use to return the requested information.

### ***buf\_size***

Size of the supplied data buffer.

### ***num\_entries***

Maximum number of users for which data should be returned. If detailed information about user sessions is being returned, this number includes partial entries (for which a client address is specified, so that the returned data does not include the user definition or the user's first session).

To request data for a specific user rather than a range, specify the value 1. To return as many entries as possible, specify zero; in this case, CS/AIX will return the maximum number of entries that can be accommodated in the supplied data buffer.

### ***list\_options***

The position in the list from which CS/AIX should begin to return data, and the level of information required for each entry. Specify the level of information with one of the following values:

#### **AP\_SUMMARY**

Summary information only.

#### **AP\_DETAIL**

Detailed information.

Combine this value using a logical OR operation with one of the following values:

#### **AP\_FIRST\_IN\_LIST**

Start at the first session for the first user in the list.

**AP\_LIST\_INCLUSIVE**

Start at the entry specified by the supplied client address and port number, or start at the first session for the specified client address if no port number is specified.

**AP\_LIST\_FROM\_NEXT**

If a port number is specified, start at the session immediately following the session with the specified port number. If no port number is specified, start at the first session for the specified client address.

The list is ordered by client address and then by port number for each user. For more information about how the list is ordered and how the application can obtain specific entries from it, see [“List options for QUERY\\_\\* Verbs”](#) on page 33.

**default\_record**

Specifies whether the requested entry (or the entry to be used as an index into the list) is the default record.

To query the default record, which is used by any TN3270 user not explicitly identified by a TCP/IP address, specify AP\_YES. In this case, the *client\_address* parameter is reserved.

To query a normal TN3270 user record, specify AP\_NO.

**client\_address**

The TCP/IP address of the TN3270 user for whom information is required, or the name to be used as an index into the list of users. This parameter is ignored if *list\_options* is set to AP\_FIRST\_IN\_LIST. The address is a null-terminated ASCII string, which can be any of the following.

- An IPv4 dotted-decimal address (such as 193.1.11.100).
- An IPv6 colon-hexadecimal address (such as 2001:0db8:0000:0000:0000:0000:1428:57ab or 2001:db8::1428:57ab).
- A name (such as newbox.this.co.uk).
- An alias (such as newbox).

**port\_number**

To return information starting with a specific session for the specified user, set this parameter to the TCP/IP port number defined for that session. To return information starting at the first session for the specified user, set this parameter to zero.

**Returned parameters: successful execution**

If the verb executes successfully, CS/AIX returns the following parameters:

**primary\_rc**

AP\_OK

**buf\_size**

Length of the information returned in the buffer.

**total\_buf\_size**

Returned value indicating the size of buffer that would have been required to return all the list information requested. This may be higher than *buf\_size*.

**total\_num\_entries**

Total number of entries that could have been returned. This may be higher than *num\_entries*.

**num\_entries**

The number of entries actually returned. The last entry may be incomplete; this is indicated by the *last\_user\_incomplete* parameter.

**num\_init\_sessions**

If the *port\_number* parameter was set to a nonzero value, so that the information for the first user in the list does not start with the user's first session, this parameter indicates the number of session structures for this user that are included in the returned data. Otherwise, this parameter is not used.

***num\_last\_sessions***

If the *last\_user\_incomplete* parameter indicates that the data for the last user is incomplete, this parameter indicates the number of session structures for this user that are included in the returned data. Otherwise, this parameter is not used.

***last\_user\_incomplete***

Specifies whether the information for the last user is incomplete. Possible values are:

**AP\_YES**

The complete data for the last user was too large to fit in the data buffer. At least one session structure is included, but there are further session structures that are not included in the data buffer. The *num\_last\_sessions* parameter indicates how many session structures have been returned; the application can issue further verbs to obtain the remaining data.

**AP\_NO**

The data for the last user is complete.

Each entry in the data buffer consists of the following:

***tn3270\_access\_summary.overlay\_size***

The size of the returned *tn3270\_access\_summary* structure, and therefore the offset to the start of the next entry in the data buffer.

When your application needs to go through the returned buffer to find each *tn3270\_access\_summary* structure in turn, it must use this value to move to the correct offset for the next data structure, and must not use the C `sizeof()` operator. This is because the size of the returned overlay may increase in future releases of CS/AIX; using the returned overlay size ensures that your application will continue to work with future releases.

***tn3270\_access\_summary.default\_record***

Specifies whether this entry is the default record. Possible values are:

**AP\_YES**

This is the default record. The *client\_address* parameter is reserved.

**AP\_NO**

This is a normal TN3270 user record.

***tn3270\_access\_summary.client\_address***

The TCP/IP address of the TN3270 user. This can be any of the following; the *address\_format* parameter indicates whether it is an IP address or a name.

- An IPv4 dotted-decimal address (such as 193.1.11.100).
- An IPv6 colon-hexadecimal address (such as 2001:0db8:0000:0000:0000:0000:1428:57ab or 2001:db8::1428:57ab).
- A name (such as newbox.this.co.uk).
- An alias (such as newbox).

***tn3270\_access\_summary.address\_format***

Specifies the format of the *client\_address* parameter. Possible values are:

**AP\_ADDRESS\_IP**

IP address (either IPv4 or IPv6)

**AP\_ADDRESS\_FQN**

Alias or fully qualified name

***tn3270\_access\_detail.overlay\_size***

The size of the returned *tn3270\_access\_detail* structure, and therefore the offset to the start of the next entry in the data buffer.

When your application needs to go through the returned buffer to find each *tn3270\_access\_detail* structure in turn, it must use this value to move to the correct offset for the next data structure, and must not use the C `sizeof()` operator. This is because the size of the returned overlay may increase in future releases of CS/AIX; using the returned overlay size ensures that your application will continue to work with future releases.



***tn3270\_access\_detail.sub\_overlay\_offset***

The offset to the start of the first session data structure for this TN3270 access record in the data buffer.

***tn3270\_access\_detail.default\_record***

Specifies whether this entry is the default record. Possible values are:

**AP\_YES**

This is the default record. The *client\_address* parameter is reserved.

**AP\_NO**

This is a normal TN3270 user record.

***tn3270\_access\_detail.client\_address***

The TCP/IP address of the TN3270 user. This is a null-terminated ASCII string, which can be any of the following.

- An IPv4 dotted-decimal address (such as 193.1.11.100).
- An IPv6 colon-hexadecimal address (such as 2001:0db8:0000:0000:0000:0000:1428:57ab or 2001:db8::1428:57ab).
- A name (such as newbox.this.co.uk).
- An alias (such as newbox).

***tn3270\_access\_detail.num\_filtered\_sessions***

The number of sessions returned for this user.

***tn3270\_access\_detail.def\_data***

The details of the user, as defined in the configuration. This is followed by a number of session structures defining the user's sessions. The format of this information is the same as for the DEFINE\_TN3270\_ACCESS verb, except for the following:

- The *num\_sessions* parameter in the *def\_data* structure defines the total number of sessions defined for the user.
- If the *port\_number* parameter was set to a nonzero value, the data for the first user will contain only the remaining session structures (starting from the requested entry), without the *def\_data* structure.
- If the *last\_user\_incomplete* parameter is set to AP\_YES, the total number of session structures returned for the last user will be as specified by the *num\_last\_sessions* parameter; this will be less than *num\_sessions*.

## Returned parameters: parameter check

If the verb does not execute because of a parameter error, CS/AIX returns the following parameters:

***primary\_rc***

AP\_PARAMETER\_CHECK

***secondary\_rc***

Possible values are:

**AP\_INVALID\_CLIENT\_ADDRESS**

The *list\_options* parameter was set to AP\_LIST\_INCLUSIVE, but the *client\_address* parameter did not match the address of any defined TN3270 user.

**AP\_INVALID\_PORT\_NUMBER**

The *list\_options* parameter was set to AP\_LIST\_INCLUSIVE, but the *port\_number* parameter did not match a port number defined for the specified TN3270 user.

**AP\_INVALID\_LIST\_OPTION**

The *list\_options* parameter was not set to a valid value.

Appendix B, “Common return codes,” on page 661 lists further secondary return codes associated with AP\_PARAMETER\_CHECK, which are common to all NOF verbs.

## Returned parameters: other conditions

Appendix B, “Common return codes,” on page 661 lists further combinations of primary and secondary return codes that are common to all NOF verbs.

## QUERY\_TN3270\_ASSOCIATION

QUERY\_TN3270\_ASSOCIATION returns information about associations between display LUs and printer LUs. Associations are queried by display LU name and are returned in order of display LU name.

This verb can be used to obtain information about a specific association or about multiple associations, depending on the options used.

## VCB structure

```
typedef struct query_tn3270_association
{
    AP_UINT16      opcode;                /* verb operation code          */
    unsigned char  reserv2;               /* reserved                     */
    unsigned char  format;               /* reserved                     */
    AP_UINT16      primary_rc;           /* primary return code          */
    AP_UINT32      secondary_rc;        /* secondary return code        */
    unsigned char  *buf_ptr;             /* pointer to buffer            */
    AP_UINT32      buf_size;             /* buffer size                  */
    AP_UINT32      total_buf_size;       /* total buffer size required   */
    AP_UINT16      num_entries;          /* number of entries            */
    AP_UINT16      total_num_entries;    /* total number of entries      */
    unsigned char  list_options;         /* listing options              */
    unsigned char  reserv3;              /* reserved                     */
    unsigned char  display_lu_name[8];   /* Display LU name              */
} QUERY_TN3270_ASSOCIATION;
```

```
typedef struct tn3270_association
{
    AP_UINT16      overlay_size;         /* Overlay size                 */
    unsigned char  reserv2[2];          /* reserved                     */
    unsigned char  display_lu_name[8];   /* Display LU name              */
    TN3270_ASSOCIATION_DEF_DATA def_data; /* association definition        */
} TN3270_ASSOCIATION;
```

```
typedef struct tn3270_association_def_data
{
    unsigned char  description[32];      /* resource description         */
    unsigned char  reserve0[16];        /* reserved                     */
    unsigned char  printer_lu_name[8];  /* name of printer LU/pool     */
    unsigned char  reserv2[8];         /* reserved                     */
} TN3270_ASSOCIATION_DEF_DATA;
```

Data is returned in the form of tn3270\_association structures.

## Supplied parameters

The application supplies the following parameters:

### **opcode**

AP\_QUERY\_TN3270\_ASSOCIATION

### **buf\_ptr**

A pointer to a data buffer that CS/AIX will use to return the requested information.

### **buf\_size**

Size of the supplied data buffer.

### **num\_entries**

Maximum number of associations for which data should be returned. To request data for a specific association rather than a range, specify the value 1. To return as many entries as possible, specify 0; in this case, CS/AIX will return the maximum number of entries that can be accommodated in the supplied data buffer.

***list\_options***

The position in the list of associations from which CS/AIX begins to return data. Specify one of the following values:

**AP\_FIRST\_IN\_LIST**

Start at the first entry in the list.

**AP\_LIST\_INCLUSIVE**

Start at the entry specified by the *display\_lu\_name* parameter.

**AP\_LIST\_FROM\_NEXT**

Start at the entry immediately following the entry specified by the *display\_lu\_name* parameter.

***display\_lu\_name***

Name of the display LU for which association information is required or the name to be used as an index into the list of associations. The display LU name is an EBCDIC string padded on the right with EBCDIC spaces. This parameter is ignored if *list\_options* is set to AP\_FIRST\_IN\_LIST.

**Returned parameters: successful execution**

If the verb executes successfully, CS/AIX returns the following parameters:

***primary\_rc***

AP\_OK

***buf\_size***

Length of the information returned in the buffer.

***total\_buf\_size***

Returned value indicating the size of buffer that would have been required to return all the list information requested. This may be higher than the value supplied for the *buf\_size* parameter.

***num\_entries***

The number of entries actually returned.

***total\_num\_entries***

Total number of entries that could have been returned. This may be higher than the value supplied for the *num\_entries* parameter.

Each entry in the data buffer consists of the following:

***tn3270\_association.overlay\_size***

The size of the returned *tn3270\_association* structure (and therefore the offset to the start of the next entry in the data buffer).

When your application needs to go through the returned buffer to find each *tn3270\_association* structure in turn, it must use this value to move to the correct offset for the next data structure, and must not use the C `sizeof()` operator. This is because the size of the returned overlay may increase in future releases of CS/AIX; using the returned overlay size ensures that your application will continue to work with future releases.

***tn3270\_association.display\_lu\_name***

Name of the display LU associated with the printer LU specified by the *association.printer\_lu\_name* parameter. This is an EBCDIC string padded on the right with EBCDIC spaces.

***tn3270\_association\_def\_data.description***

A null-terminated text string that describe the association, as specified in the definition of the association.

***tn3270\_association\_def\_data.printer\_lu\_name***

Name of the printer LU associated with the display LU specified by the *association.display\_lu\_name* parameter. This is an EBCDIC string padded on the right with EBCDIC spaces.

**Returned parameters: parameter check**

If the verb does not execute because of a parameter error, CS/AIX returns the following parameters:

## QUERY\_TN3270\_DEFAULTS

### *primary\_rc*

AP\_PARAMETER\_CHECK

### *secondary\_rc*

Possible values are:

#### **AP\_INVALID\_LIST\_OPTION**

The *list\_options* parameter was not set to a valid value.

#### **AP\_INVALID\_LU\_NAME**

Indicates one of the following:

- The *list\_options* parameter was set to AP\_LIST\_FROM\_NEXT, but the display LU name was not a valid EBCDIC string.
- The *list\_options* parameter was set to AP\_LIST\_INCLUSIVE, but the display LU name either was not a valid EBCDIC string or did not correspond to an existing association record.

Appendix B, “Common return codes,” on page 661 lists further secondary return codes associated with AP\_PARAMETER\_CHECK, which are common to all NOF verbs.

## Returned parameters: other conditions

Appendix B, “Common return codes,” on page 661 lists further combinations of primary and secondary return codes that are common to all NOF verbs.

## QUERY\_TN3270\_DEFAULTS

QUERY\_TN3270\_DEFAULTS returns information about TN3270 parameters used on all client sessions.

If you are using Secure Sockets Layer (SSL) client authentication, and checking clients against a certificate revocation list on an external LDAP server, use the QUERY\_TN3270\_SSL\_LDAP verb to return details of how to access this server.

## VCB structure

```
typedef struct query_tn3270_defaults
{
    AP_UINT16      opcode;           /* verb operation code          */
    unsigned char  reserv2;         /* reserved                     */
    unsigned char  format;         /* reserved                     */
    AP_UINT16      primary_rc;     /* primary return code          */
    AP_UINT32      secondary_rc;   /* secondary return code        */
    TN3270_DEFAULTS_DEF_DATA def_data; /* TN3270 defaults             */
} QUERY_TN3270_DEFAULTS;
```

```
typedef struct tn3270_defaults_def_data
{
    AP_UINT16      force_responses; /* force printer responses?     */
    AP_UINT16      keepalive_method; /* method for sending keep-alives */
    AP_UINT32      keepalive_interval; /* interval between keep-alives */
    unsigned char  reserv2[32];     /* reserved                     */
} TN3270_DEFAULTS_DEF_DATA;
```

## Supplied parameters

The application supplies the following parameter:

### *opcode*

AP\_QUERY\_TN3270\_DEFAULTS

## Returned parameters: successful execution

If the verb executes successfully, CS/AIX returns the following parameters:

**primary\_rc**

AP\_OK

**def\_data.force\_responses**

Controls client responses on printer sessions. Possible values are:

**AP\_YES**

Requests definite responses.

**AP\_NO**

Request responses matching SNA traffic.

**def\_data.keepalive\_method**

Method for sending keep-alive messages. Keep-alive messages are messages sent to TN3270 clients when there is no other activity on the connection, to keep the TCP/IP connections to the clients active; this ensures that failed connections and clients can be detected. If there is no traffic at all on a TCP/IP connection, failure of the connection or of the client may never be detected, which wastes TN server resources and prevents LUs from being used for other sessions.

Possible values are:

**AP\_NONE**

Do not send keep-alive messages.

**AP\_TN3270\_NOP**

Send Telnet NOP messages.

**AP\_TN3270\_TM**

Send Telnet DO TIMING-MARK messages.

**def\_data.keepalive\_interval**

Interval (in seconds) between consecutive keep-alive messages. The interval should be long enough to minimize network traffic, especially if there are typically many idle client connections. The shorter the keep-alive interval, the quicker failures are detected, but the more network traffic is generated. If the keep-alive interval is too short and there are many clients, this traffic can be significant.

Because of the way TCP/IP operates, the keepalive interval that you configure is not the exact time that it will take for the server to recognize that a client has disappeared. The exact time depends on various factors, but will be no more than twice the configured timeout plus a few extra minutes (the exact number depends on how TCP/IP is configured).

**Returned parameters: other conditions**

Appendix B, “Common return codes,” on page 661 lists further combinations of primary and secondary return codes that are common to all NOF verbs.

**QUERY\_TN3270\_EXPRESS\_LOGON**

QUERY\_TN3270\_EXPRESS\_LOGON returns information about the TN3270 Express Logon feature. This feature means that TN3270 client users who connect to CS/AIX TN Server or TN Redirector using the Secure Sockets Layer (SSL) client authentication feature do not need to supply the user ID and password normally used for TN3270 security. Instead, their security certificate is checked against a Digital Certificate Access Server (DCAS) at the host, which supplies the required user ID and password.

**VCB structure**

```
typedef struct query_tn3270_express_logon
{
    AP_UINT16      opcode;                /* verb operation code          */
    unsigned char  reserv2;               /* reserved                      */
    unsigned char  format;                /* reserved                      */
    AP_UINT16      primary_rc;            /* primary return code          */
    AP_UINT32      secondary_rc;          /* secondary return code        */
    unsigned char  dcas_server[256];     /* IP hostname of DCAS server   */
    AP_UINT16      dcas_port;             /* port number to access server */
    unsigned char  enabled;               /* is Express Logon enabled?    */
}
```

## QUERY\_TN3270\_SLP

```
    unsigned char    reserv3[33];           /* reserved          */
} QUERY_TN3270_EXPRESS_LOGON;           */
```

### Supplied parameters

The application supplies the following parameter:

#### *opcode*

AP\_QUERY\_TN3270\_EXPRESS\_LOGON

### Returned parameters: successful execution

If the verb executes successfully, CS/AIX returns the following parameters:

#### *primary\_rc*

AP\_OK

#### *dcas\_server*

The TCP/IP address of the host DCAS server that handles Express Logon authorization. This can be specified as any of the following.

- An IPv4 dotted-decimal address (such as 193.1.11.100).
- An IPv6 colon-hexadecimal address (such as 2001:0db8:0000:0000:0000:0000:1428:57ab or 2001:db8::1428:57ab).
- A name (such as newbox.this.co.uk).
- An alias (such as newbox).

#### *dcas\_port*

The TCP/IP port number used to access the DCAS server.

#### *enabled*

Specifies whether the TN3270 Express Logon function is enabled. Possible values are:

##### **AP\_YES**

The function is enabled, so TN3270 clients can access the host without needing to specify a user ID and password.

##### **AP\_NO**

The function is not enabled, so TN3270 clients must specify a user ID and password.

### Returned parameters: other conditions

Appendix B, “Common return codes,” on page 661 lists further combinations of primary and secondary return codes that are common to all NOF verbs.

## QUERY\_TN3270\_SLP

QUERY\_TN3270\_SLP returns information about whether CS/AIX TN Server provides Service Location Protocol (SLP) support, and how the TN Server advertises its services for use by TN3270 clients. This information was specified using the DEFINE\_TN3270\_SLP verb.

### VCB structure

```
typedef struct query_tn3270_slp
{
    AP_UINT16          opcode;           /* verb operation code    */
    unsigned char     reserv2;           /* reserved                */
    unsigned char     format;           /* reserved                */
    AP_UINT16          primary_rc;       /* primary return code    */
    AP_UINT32          secondary_rc;     /* secondary return code  */
    TN3270_SLP         slp_config;      /* SLP configuration      */
    TN3270_SLP_DET_DATA det_data;       /* SLP determined data   */
} QUERY_TN3270_SLP;
```

```

typedef struct tn3270_slp
{
    unsigned char    enable_load_balancing;    /* Use this feature?          */
    unsigned char    reserve1;                /* Reserved                    */
    AP_UINT16        load_advertisement_freq; /* Frequency of calculating load */
    AP_UINT16        load_change_threshold;   /* Change in load required to  */
                                                /* readvertise                 */
    AP_INT16         load_factor;             /* Percentage factor to apply to */
                                                /* load                        */
    unsigned char    num_scopes;              /* count of SLP scope names    */
    TN3270_SLP_SCOPE slp_scopes[10];        /* A set of scopes for the     */
                                                /* TN3270 SLP/SA               */
    unsigned char    reserved[64];           /* Reserved                     */
} TN3270_SLP;

```

```

typedef struct tn3270_slp_scope
{
    unsigned char    scope[32];              /* Scope (null-terminated string) */
} TN3270_SLP_SCOPE;

```

```

typedef struct tn3270_slp_det_data
{
    AP_UINT16        current_load;           /* Advertised load            */
    unsigned char    reserved[30];          /* Reserved                    */
} TN3270_SLP_DET_DATA;

```

## Supplied parameters

The application supplies the following parameter:

### *opcode*

AP\_QUERY\_TN3270\_SLP

## Returned parameters: successful execution

If the verb executes successfully, CS/AIX returns the following parameters:

### *primary\_rc*

AP\_OK

### *slp\_config.enable\_load\_balancing*

Specifies whether TN Server provides SLP support. Possible values are:

#### **AP\_YES**

TN Server provides SLP support.

#### **AP\_NO**

TN Server does not provide SLP support. All other parameters for this verb are reserved.

### *slp\_config.load\_advertisement\_freq*

Specifies the time interval (in seconds) at which CS/AIX recalculates the load on TN Server, to determine whether the load has changed significantly and needs to be re-advertised.

### *slp\_config.load\_change\_threshold*

Specifies the change in load that is considered significant and requires re-advertising of the current load. When CS/AIX recalculates the load on TN Server, it checks whether the current load differs from the advertised load by more than this amount (either higher or lower), and advertises the new load only if the difference is significant. For example, if the last advertised load value is 30%, a value of 10 indicates that CS/AIX re-advertises the load only if the current load becomes higher than 40% or lower than 20%.

### *slp\_config.load\_factor*

Specifies a percentage factor that CS/AIX should apply to the advertised load, to provide better balancing between TN Servers of different capacities. For example, if one TN Server is running on a faster computer with more available memory than another TN Server, you will probably want clients to choose the first TN Server when both have the same load (in terms of the percentage of their host LUs that are in use). In this case, specify a lower *load\_factor* for the first TN Server and a higher one for

## QUERY\_TN3270\_SLP\_TRACE

the second TN Server, so that the second TN Server's advertised load is higher even when the actual percentage load is the same.

The load factor is a percentage in the range -100 - 100. The advertised load is calculated by adding 100 to this value and multiplying the actual percentage load by the result. For example, if the load factor is -80, the advertised load is the actual load multiplied by (-80 + 100) or 20%; if the load factor 50, the advertised load is the actual load multiplied by (50 + 100) or 150%.

### ***slp\_config.slp\_scopes***

In a large SLP network with many TN Servers and TN3270 clients, you may need to restrict the range of TN Servers that each client can access. To do this, you can define a number of scopes, each of which identifies a logical segment of the network. Each client and each Directory Agent is assigned to a particular scope; a TN Server advertises its services only to clients and Directory Agents that have the correct scope.

If each element of this array is set to a null string, the TN Server's services are advertised to any TN3270 client or Directory Agent.

Any non-null strings in this array specify scope names for which this TN Server provides services. Each scope name is an ASCII string (terminated by a null character); all clients and Directory Agents that are to have access to the TN Server must have a scope name defined that matches a scope name defined for the TN Server. Any unused scope names are set to null strings.

### ***det\_data.current\_load***

The load currently being advertised by this TN Server.

## Returned parameters: other conditions

Appendix B, “Common return codes,” on page 661 lists further combinations of primary and secondary return codes that are common to all NOF verbs.

## QUERY\_TN3270\_SLP\_TRACE

---

This verb returns information about the current tracing options for the CS/AIX TN3270 Service Location Protocol feature.

This verb must be issued to a running node.

## VCB structure

```
typedef struct query_tn3270_slp_trace
{
    AP_UINT16      opcode;                /* verb operation code      */
    unsigned char  reserv2;              /* reserved                  */
    unsigned char  format;               /* reserved                  */
    AP_UINT16      primary_rc;           /* primary return code      */
    AP_UINT32      secondary_rc;        /* secondary return code    */
    AP_UINT16      trace_flags;         /* trace flags              */
    unsigned char  reserv3[6];          /* Reserved                  */
} QUERY_TN3270_SLP_TRACE;
```

## Supplied parameters

The application supplies the following parameter:

### ***opcode***

AP\_QUERY\_TN3270\_SLP\_TRACE

## Returned parameters: successful execution

If the verb executes successfully, CS/AIX returns the following parameters:

### ***primary\_rc***

AP\_OK



**secondary\_rc**

Not used.

**trace\_flags**

The types of tracing currently active.

If no tracing is active, or if tracing of all types is active, this is one of the following values:

**AP\_TN3270\_SLP\_NO\_TRACE**

No tracing.

**AP\_TN3270\_SLP\_ALL\_TRACE**

Tracing of all types.

If tracing is being used on specific interfaces, this parameter is set to one or more values from the list below, combined using a logical OR operation.

**AP\_TN3270\_SLP\_TRC\_CFG**

Configuration message tracing: messages relating to the configuration of TN3270 SLP

**AP\_TN3270\_SLP\_TRC\_NOF**

Internal node operator function (NOF) tracing: trace NOF requests made by TN3270 SLP

**AP\_TN3270\_SLP\_TRC\_TCP**

TCP/IP interface tracing: messages between TN3270 SLP and TN3270 clients

**Returned parameters: other conditions**

Appendix B, “Common return codes,” on page 661 lists further combinations of primary and secondary return codes that are common to all NOF verbs.

**QUERY\_TN3270\_SSL\_LDAP**

QUERY\_TN3270\_SSL\_LDAP returns information about how to access a certificate revocation list for use with the Secure Sockets Layer (SSL) client authentication feature. This information was specified using the DEFINE\_TN3270\_SSL\_LDAP verb.

**VCB structure**

```
typedef struct query_tn3270_ssl_ldap
{
    AP_UINT16      opcode;                /* verb operation code          */
    unsigned char  reserv2;               /* reserved                      */
    unsigned char  format;               /* reserved                      */
    AP_UINT16      primary_rc;           /* primary return code          */
    AP_UINT32      secondary_rc;         /* secondary return code        */
    unsigned char  *buf_ptr;             /* pointer to buffer            */
    AP_UINT32      buf_size;             /* buffer size                  */
    AP_UINT32      total_buf_size;       /* total buffer size required   */
    AP_UINT16      num_entries;          /* reserved                      */
    AP_UINT16      total_num_entries;    /* reserved                      */
    unsigned char  list_options;         /* reserved                      */
    unsigned char  reserv3;             /* reserved                      */
} QUERY_TN3270_SSL_LDAP;
```

```
typedef struct tn3270_ssl_ldap_def_data
{
    AP_UINT16      overlay_size;         /* reserved                      */
    unsigned char  auth_type;           /* type of authorization checking */
    unsigned char  reserv1;             /* reserved                      */
    unsigned char  ldap_addr[256];      /* address of LDAP server        */
    AP_UINT16      ldap_port;           /* port number to access server  */
    unsigned char  ldap_user[1024];     /* user ID on LDAP server        */
    unsigned char  ldap_password[128];  /* password on LDAP server       */
    unsigned char  reserv2[256];        /* reserved                      */
} TN3270_SSL_LDAP_DEF_DATA;
```

## Supplied parameters

The application supplies the following parameter:

***opcode***

AP\_QUERY\_TN3270\_SSL\_LDAP

***buf\_ptr***

A pointer to a data buffer that CS/AIX will use to return the requested information.

***buf\_size***

Size of the supplied data buffer.

## Returned parameters: successful execution

If the verb executes successfully, CS/AIX returns the following parameters:

***primary\_rc***

AP\_OK

***buf\_size***

Length of the information returned in the buffer.

***total\_buf\_size***

Returned value indicating the size of buffer that would have been required to return the complete information. This may be higher than the value supplied for the *buf\_size* parameter.

The following information is returned in the data buffer:

***def\_data.auth\_type***

Specifies the type of authorization checking performed by the TN Server or TN Redirector. Possible values are:

**AP\_LOCAL\_ONLY**

The server checks client certificates locally, but does not use an external certificate revocation list. The parameters *ldap\_addr* - *ldap\_password* are reserved.

**AP\_LOCAL\_X500**

The server checks certificates locally, and also checks against an external certificate revocation list. The remaining parameters in this data structure specify the location of this list.

***def\_data.ldap\_addr***

The TCP/IP address of the LDAP server that holds the certificate revocation list. This can be specified as any of the following.

- An IPv4 dotted-decimal address (such as 193.1.11.100).
- An IPv6 colon-hexadecimal address (such as 2001:0db8:0000:0000:0000:0000:1428:57ab or 2001:db8::1428:57ab).
- A name (such as newbox.this.co.uk).
- An alias (such as newbox).

***def\_data.ldap\_port***

The TCP/IP port number used to access the LDAP server. The range is 0-65535.

***def\_data.ldap\_user***

The user name used to access the certificate revocation list on the LDAP server.

***def\_data.ldap\_password***

The password used to access the certificate revocation list on the LDAP server.

## Returned parameters: other conditions

Appendix B, “[Common return codes](#),” on page 661 lists further combinations of primary and secondary return codes that are common to all NOF verbs.

## QUERY\_TN\_REDIRECT\_DEF

QUERY\_TN\_REDIRECT\_DEF returns information about Telnet clients on other computers that can use the TN Redirector feature of CS/AIX to access a host. It can return either summary or detailed information, about a single user or multiple users, depending on the options used.

### VCB structure

```
typedef struct query_tn_redirect_def
{
    AP_UINT16      opcode;           /* verb operation code          */
    unsigned char  reserv2;         /* reserved                     */
    unsigned char  format;         /* reserved                     */
    AP_UINT16      primary_rc;     /* primary return code         */
    AP_UINT32      secondary_rc;   /* secondary return code       */
    unsigned char  *buf_ptr;       /* pointer to buffer           */
    AP_UINT32      buf_size;       /* buffer size                 */
    AP_UINT32      total_buf_size; /* total buffer size required  */
    AP_UINT16      num_entries;    /* number of entries           */
    AP_UINT16      total_num_entries; /* total number of entries    */
    unsigned char  list_options;   /* listing options             */
    unsigned char  reserv3[3];     /* reserved                    */
    TN_REDIRECT_ADDRESS addr;      /* Uniquely defines record    */
} QUERY_TN_REDIRECT_DEF;
```

```
typedef struct tn_redirect_data
{
    AP_UINT16      overlay_size;   /* overlay size                */
    unsigned char  reserv1[2];    /* Reserved                    */
    TN_REDIRECT_ADDRESS addr;     /* addressing information      */
    TN_REDIRECT_DEF_DATA def_data; /* definitions for the client  */
} TN_REDIRECT_DATA;
```

```
typedef struct tn_redirect_address
{
    AP_UINT16      default_record; /* Is this the default record ? */
    unsigned char  address_format; /* IP address or fully-qualified name */
    unsigned char  client_address[256]; /* Client address */
    AP_UINT16      port_number;    /* Port number that client connects on */
    unsigned char  listen_local_address[46]; /* Local addr client connects to */
    unsigned char  reserved[34];   /* reserved */
} TN_REDIRECT_ADDRESS;
```

```
typedef struct tn_redirect_def_data
{
    unsigned char  description[32]; /* Description - null terminated */
    unsigned char  reserve0[16];   /* Reserved */
    unsigned char  cli_ssl_enabled; /* Is the client session SSL? */
    unsigned char  host_ssl_enabled; /* Is the host session SSL? */
    unsigned char  host_address_format; /* Type of IP address for the host */
    unsigned char  reserv1;       /* Reserved */
    unsigned char  host_address[256]; /* Host address */
    AP_UINT16      host_port_number; /* Port number to connect to host */
    unsigned char  cli_conn_security_level; /* SSL encryption strength */
    unsigned char  serv_conn_security_level; /* SSL encryption strength */
    unsigned char  cli_conn_cert_key_label[80]; /* Key label for certificate */
    unsigned char  serv_conn_cert_key_label[80]; /* Key label for certificate */
    unsigned char  reserved[46];   /* Reserved */
} TN_REDIRECT_DEF_DATA;
```

### Supplied parameters

The application supplies the following parameters:

#### **opcode**

AP\_QUERY\_TN\_REDIRECT\_DEF

#### **buf\_ptr**

A pointer to a data buffer that CS/AIX will use to return the requested information.

**buf\_size**

Size of the supplied data buffer.

**num\_entries**

Maximum number of users for which data should be returned. To request data for a specific user rather than a range, specify the value 1. To return as many entries as possible, specify zero; in this case, CS/AIX will return the maximum number of entries that can be accommodated in the supplied data buffer.

**list\_options**

The position in the list from which CS/AIX should begin to return data, and the level of information required for each entry. Specify one of the following values:

**AP\_FIRST\_IN\_LIST**

Start at the first user in the list.

**AP\_LIST\_INCLUSIVE**

Start at the entry specified by the supplied client addressing information.

**AP\_LIST\_FROM\_NEXT**

Start at the entry immediately following the entry specified by the supplied client addressing information.

The list is ordered by client address. For more information about how the list is ordered and how the application can obtain specific entries from it, see [“List options for QUERY\\_\\* Verbs” on page 33](#).

**addr**

Specifies addressing information for the Telnet client for whom information is required, or the user to be used as an index into the list of users. For more information about the contents of this data structure, see [“DEFINE\\_TN\\_REDIRECT” on page 194](#).

The information in this structure is ignored if *list\_options* is set to AP\_FIRST\_IN\_LIST.

## Returned parameters: successful execution

If the verb executes successfully, CS/AIX returns the following parameters:

**primary\_rc**

AP\_OK

**buf\_size**

Length of the information returned in the buffer.

**total\_buf\_size**

Returned value indicating the size of buffer that would have been required to return all the list information requested. This may be higher than *buf\_size*.

**total\_num\_entries**

Total number of entries that could have been returned. This may be higher than *num\_entries*.

**num\_entries**

The number of entries actually returned.

**tn\_redirect\_data.overlay\_size**

The size of the returned *tn\_redirect\_data* structure, and therefore the offset to the start of the next entry in the data buffer.

When your application needs to go through the returned buffer to find each *tn\_redirect\_data* structure in turn, it must use this value to move to the correct offset for the next data structure, and must not use the C `sizeof()` operator. This is because the size of the returned overlay may increase in future releases of CS/AIX; using the returned overlay size ensures that your application will continue to work with future releases.

**tn\_redirect\_data.addr**

Specifies addressing information for the Telnet client. For more information about the contents of this data structure, see [“DEFINE\\_TN\\_REDIRECT” on page 194](#).

***tn\_redirect\_data.def\_data***

Specifies definitions for the Telnet client. For more information about the contents of this data structure, see [“DEFINE\\_TN\\_REDIRECT” on page 194](#).

**Returned parameters: parameter check**

If the verb does not execute because of a parameter error, CS/AIX returns the following parameters:

***primary\_rc***

AP\_PARAMETER\_CHECK

***secondary\_rc***

Possible values are:

**AP\_INVALID\_CLIENT\_ADDRESS**

The *list\_options* parameter was set to AP\_LIST\_INCLUSIVE, but the supplied addressing information did not match any defined TN Redirector user.

**AP\_INVALID\_LIST\_OPTION**

The *list\_options* parameter was not set to a valid value.

Appendix B, [“Common return codes,” on page 661](#) lists further secondary return codes associated with AP\_PARAMETER\_CHECK, which are common to all NOF verbs.

**Returned parameters: other conditions**

Appendix B, [“Common return codes,” on page 661](#) lists further combinations of primary and secondary return codes that are common to all NOF verbs.

**QUERY\_TN\_SERVER\_TRACE**

This verb returns information about the current tracing options for the CS/AIX TN server feature.

This verb must be issued to a running node.

**VCB structure**

```
typedef struct query_tn_server_trace
{
    AP_UINT16      opcode;           /* verb operation code      */
    unsigned char  reserv2;         /* reserved                  */
    unsigned char  format;         /* reserved                  */
    AP_UINT16      primary_rc;     /* primary return code      */
    AP_UINT32      secondary_rc;   /* secondary return code    */
    AP_UINT16      trace_flags;    /* trace flags              */
    unsigned char  reserv3[6];     /* Reserved                  */
} QUERY_TN_SERVER_TRACE;
```

**Supplied parameters**

The application supplies the following parameter:

***opcode***

AP\_QUERY\_TN\_SERVER\_TRACE

**Returned parameters: successful execution**

If the verb executes successfully, CS/AIX returns the following parameters:

***primary\_rc***

AP\_OK

***secondary\_rc***

Not used.

## QUERY\_TP

### *trace\_flags*

The types of tracing currently active.

If no tracing is active, or if tracing of all types is active, this is one of the following values:

#### **AP\_TN\_SERVER\_NO\_TRACE**

No tracing.

#### **AP\_TN\_SERVER\_ALL\_TRACE**

Tracing of all types.

If tracing is being used on specific interfaces, this parameter is set to one or more values from the list below, combined using a logical OR operation.

#### **AP\_TN\_SERVER\_TRC\_TCP**

TCP/IP interface tracing: messages between TN server and TN3270 clients

#### **AP\_TN\_SERVER\_TRC\_FM**

Node interface tracing: internal control messages, and messages between TN server and TN3270 clients (in internal format)

#### **AP\_TN\_SERVER\_TRC\_CFG**

Configuration message tracing: messages relating to the configuration of TN server

## Returned parameters: other conditions

Appendix B, “Common return codes,” on page 661 lists further combinations of primary and secondary return codes that are common to all NOF verbs.

## QUERY\_TP

QUERY\_TP returns information about TPs that are currently using a local LU. This verb can be used to obtain information about a specific TP or about multiple TPs, depending on the options used. This verb returns information about current usage of the TPs, not about their definition; use QUERY\_TP\_DEFINITION to obtain the definition of the TPs.

This verb must be issued to a running node.

## VCB structure

```
typedef struct query_tp
{
    AP_UINT16      opcode;                /* Verb operation code      */
    unsigned char  reserv2;               /* reserved                  */
    unsigned char  format;                /* reserved                  */
    AP_UINT16      primary_rc;            /* Primary return code      */
    AP_UINT32      secondary_rc;          /* Secondary return code    */
    unsigned char  *buf_ptr;              /* pointer to buffer        */
    AP_UINT32      buf_size;              /* buffer size              */
    AP_UINT32      total_buf_size;        /* total buffer size required */
    AP_UINT16      num_entries;           /* number of entries        */
    AP_UINT16      total_num_entries;     /* total number of entries  */
    unsigned char  list_options;          /* listing options          */
    unsigned char  reserv3;               /* reserved                  */
    unsigned char  lu_name[8];            /* LU name                  */
    unsigned char  lu_alias[8];           /* LU alias                  */
    unsigned char  tp_name[64];           /* TP name                  */
} QUERY_TP;
```

```
typedef struct tp_data
{
    AP_UINT16      overlay_size;           /* size of returned entry   */
    unsigned char  tp_name[64];           /* TP name                  */
    unsigned char  description[32];        /* resource description     */
    unsigned char  reserv1[16];           /* reserved                  */
    AP_UINT16      instance_limit;         /* maximum instance count   */
    AP_UINT16      instance_count;         /* current instance count   */
    AP_UINT16      locally_started_count;  /* locally started instance */
    unsigned char  count;                 /* count                    */
    AP_UINT16      remotely_started_count; /* remotely started instance */
}
```

```

        unsigned char   reserva[20];           /* count          */
    } TP_DATA;          /* reserved       */

```

## Supplied parameters

The application supplies the following parameters:

### **opcode**

AP\_QUERY\_TP

### **buf\_ptr**

A pointer to a data buffer that CS/AIX will use to return the requested information.

### **buf\_size**

Size of the supplied data buffer.

### **num\_entries**

Maximum number of TPs for which data should be returned. To request data for a specific TP rather than a range, specify the value 1. To return as many entries as possible, specify zero; in this case, CS/AIX will return the maximum number of entries that can be accommodated in the supplied data buffer.

### **list\_options**

The position in the list of TPs from which CS/AIX should begin to return data. Possible values are:

#### **AP\_FIRST\_IN\_LIST**

Start at the first entry in the list.

#### **AP\_LIST\_INCLUSIVE**

Start at the entry specified by the combination of LU name and TP name.

#### **AP\_LIST\_FROM\_NEXT**

Start at the entry immediately following the entry specified by the combination of LU name and TP name.

For more information about how the list is ordered and how the application can obtain specific entries from it, see [“List options for QUERY\\_\\* Verbs”](#) on page 33.

### **lu\_name**

LU name. This is an 8-byte type-A EBCDIC string, padded on the right with spaces if the name is shorter than 8 characters. To specify that the LU is identified by its alias rather than its LU name, set this parameter to 8 binary zeros and specify the LU alias in the following parameter. To specify the LU associated with the local CP (the default LU), set both *lu\_name* and *lu\_alias* to binary zeros.

### **lu\_alias**

Locally defined LU alias. This is an 8-byte ASCII string, padded on the right with spaces if the name is shorter than 8 bytes. This parameter is used only if *lu\_name* is set to 8 binary zeros; it is ignored otherwise. To specify the LU associated with the local CP (the default LU), set both *lu\_name* and *lu\_alias* to binary zeros.

### **tp\_name**

TP name. This is a 64-byte string, padded on the right with spaces if the name is shorter than 64 characters. This value is ignored if *list\_options* is set to AP\_FIRST\_IN\_LIST.

## Returned parameters: successful execution

If the verb executes successfully, CS/AIX returns the following parameters:

### **primary\_rc**

AP\_OK

### **buf\_size**

Length of the information returned in the supplied buffer.

***total\_buf\_size***

Returned value indicating the size of buffer that would have been required to return all the list information requested. A value greater than *buf\_size* indicates that not all the available entries were returned.

***num\_entries***

Number of entries returned in the data buffer.

***total\_num\_entries***

Total number of entries available. A value greater than *num\_entries* indicates that not all the available entries were returned.

Each entry in the data buffer consists of the following parameters:

***tp\_data.overlay\_size***

The size of the returned *tp\_data* structure, and therefore the offset to the start of the next entry in the data buffer.

When your application needs to go through the returned buffer to find each *tp\_data* structure in turn, it must use this value to move to the correct offset for the next data structure, and must not use the C `sizeof()` operator. This is because the size of the returned overlay may increase in future releases of CS/AIX; using the returned overlay size ensures that your application will continue to work with future releases.

***tp\_data.tp\_name***

TP name. This is a 64-byte string, padded on the right with spaces if the name is shorter than 64 characters.

***tp\_data.description***

A null-terminated text string describing the TP, as specified in the definition of the TP.

***tp\_data.instance\_limit***

Maximum number of concurrently active instances of the specified TP.

***tp\_data.instance\_count***

Number of instances of the specified TP that are currently active.

***tp\_data.locally\_started\_count***

Number of instances of the TP that have been started locally (by the TP issuing a TP\_STARTED verb).

***tp\_data.remotely\_started\_count***

Number of instances of the TP that have been started remotely (by a received Attach request).

## Returned parameters: parameter check

If the verb does not execute because of a parameter error, CS/AIX returns the following parameters:

***primary\_rc***

AP\_PARAMETER\_CHECK

***secondary\_rc***

Possible values are:

**AP\_INVALID\_LIST\_OPTION**

The *list\_options* parameter was not set to a valid value.

**AP\_INVALID\_LU\_ALIAS**

The supplied *lu\_alias* parameter was not valid.

**AP\_INVALID\_LU\_NAME**

The supplied *lu\_name* parameter was not valid.

**AP\_INVALID\_TP\_NAME**

The *list\_options* parameter was set to AP\_LIST\_INCLUSIVE to list all entries starting from the supplied name, but the *tp\_name* parameter was not valid.

Appendix B, "Common return codes," on page 661 lists further secondary return codes associated with AP\_PARAMETER\_CHECK, which are common to all NOF verbs.



## Returned parameters: other conditions

Appendix B, “Common return codes,” on page 661 lists further combinations of primary and secondary return codes that are common to all NOF verbs.

## QUERY\_TP\_DEFINITION

QUERY\_TP\_DEFINITION returns information about TPs defined on the CS/AIX system. This verb can be used to obtain information about a specific TP or about multiple TPs, depending on the options used. It returns information about the definition of the TPs, not about their current usage; use QUERY\_TP to obtain the usage information.

## VCB structure

```
typedef struct query_tp_definition
{
    AP_UINT16      opcode;                /* Verb operation code          */
    unsigned char  reserv2;               /* reserved                     */
    unsigned char  format;               /* reserved                     */
    AP_UINT16      primary_rc;           /* Primary return code         */
    AP_UINT32      secondary_rc;        /* Secondary return code       */
    unsigned char  *buf_ptr;             /* pointer to buffer           */
    AP_UINT32      buf_size;             /* buffer size                 */
    AP_UINT32      total_buf_size;       /* total buffer size required  */
    AP_UINT16      num_entries;          /* number of entries           */
    AP_UINT16      total_num_entries;    /* total number of entries     */
    unsigned char  list_options;         /* listing options             */
    unsigned char  reserv3;              /* reserved                     */
    unsigned char  tp_name[64];         /* TP name                     */
} QUERY_TP_DEFINITION;
```

```
typedef struct tp_def_summary
{
    AP_UINT16      overlay_size;         /* size of returned entry      */
    unsigned char  tp_name[64];         /* TP name                     */
    unsigned char  description[32];     /* resource description        */
    unsigned char  reserv1[16];        /* reserved                    */
} TP_DEF_SUMMARY;
```

```
typedef struct tp_def_detail
{
    AP_UINT16      overlay_size;         /* size of returned entry      */
    unsigned char  tp_name[64];         /* TP name                     */
    TP_CHARS      tp_chars;             /* TP characteristics         */
} TP_DEF_DETAIL;
```

```
typedef struct tp_chars
{
    unsigned char  description[32];     /* resource description        */
    unsigned char  security_list_name[14]; /* security access list name  */
    unsigned char  reserv1[2];         /* reserved                    */
    unsigned char  conv_type;          /* conversation type          */
    unsigned char  security_rqd;       /* security support           */
    unsigned char  sync_level;         /* synchronization level support */
    unsigned char  dynamic_load;       /* dynamic load               */
    unsigned char  enabled;            /* is the TP enabled?        */
    unsigned char  pip_allowed;        /* program initialization     */
    unsigned char  reserv2;             /* reserved                    */
    unsigned char  reserv3[10];        /* reserved                    */
    AP_UINT16      tp_instance_limit;  /* limit on currently active TP */
    AP_UINT16      instances;          /* instances                  */
    AP_UINT16      incoming_alloc_timeout; /* incoming allocation timeout */
    AP_UINT16      rcv_alloc_timeout;  /* receive allocation timeout  */
    AP_UINT16      tp_data_len;        /* reserved                   */
    unsigned char  tp_data[120];      /* reserved                   */
} TP_CHARS;
```

## Supplied parameters

The application supplies the following parameters:

## QUERY\_TP\_DEFINITION

### ***opcode***

AP\_QUERY\_TP\_DEFINITION

### ***buf\_ptr***

A pointer to a data buffer that CS/AIX will use to return the requested information.

### ***buf\_size***

Size of the supplied data buffer.

### ***num\_entries***

Maximum number of TPs for which data should be returned. To request data for a specific TP rather than a range, specify the value 1. To return as many entries as possible, specify zero; in this case, CS/AIX will return the maximum number of entries that can be accommodated in the supplied data buffer.

### ***list\_options***

The position in the list from which CS/AIX should begin to return data, and the level of information required for each entry. Specify the level of information with one of the following values:

#### **AP\_SUMMARY**

Summary information only.

#### **AP\_DETAIL**

Detailed information.

Combine this value using a logical OR operation with one of the following values:

#### **AP\_FIRST\_IN\_LIST**

Start at the first entry in the list.

#### **AP\_LIST\_INCLUSIVE**

Start at the entry specified by the *tp\_name* parameter.

#### **AP\_LIST\_FROM\_NEXT**

Start at the entry immediately following the entry specified by the *tp\_name* parameter.

For more information about how the list is ordered and how the application can obtain specific entries from it, see [“List options for QUERY\\_\\* Verbs”](#) on page 33.

### ***tp\_name***

TP name. This is a 64-byte string, padded on the right with spaces if the name is shorter than 64 characters. This parameter is ignored if *list\_options* is set to AP\_FIRST\_IN\_LIST.

## Returned parameters: successful execution

If the verb executes successfully, CS/AIX returns the following parameters:

### ***primary\_rc***

AP\_OK

### ***buf\_size***

Length of the information returned in the supplied buffer.

### ***total\_buf\_size***

Returned value indicating the size of buffer that would have been required to return all the list information requested. A value greater than *buf\_size* indicates that not all the available entries were returned.

### ***num\_entries***

Number of entries returned in the data buffer.

### ***total\_num\_entries***

Total number of entries available. A value greater than *num\_entries* indicates that not all the available entries were returned.

Each entry in the data buffer consists of the following parameters:

***tp\_def\_summary.overlay\_size***

The size of the returned `tp_def_summary` structure, and therefore the offset to the start of the next entry in the data buffer.

When your application needs to go through the returned buffer to find each `tp_def_summary` structure in turn, it must use this value to move to the correct offset for the next data structure, and must not use the C `sizeof()` operator. This is because the size of the returned overlay may increase in future releases of CS/AIX; using the returned overlay size ensures that your application will continue to work with future releases.

***tp\_def\_summary.tp\_name***

TP name. This is a 64-byte string, padded on the right with spaces if the name is shorter than 64 characters.

***tp\_def\_summary.description***

A null-terminated text string describing the TP, as specified in the definition of the TP.

***tp\_def\_detail.overlay\_size***

The size of the returned `tp_def_detail` structure, and therefore the offset to the start of the next entry in the data buffer.

When your application needs to go through the returned buffer to find each `tp_def_detail` structure in turn, it must use this value to move to the correct offset for the next data structure, and must not use the C `sizeof()` operator. This is because the size of the returned overlay may increase in future releases of CS/AIX; using the returned overlay size ensures that your application will continue to work with future releases.

***tp\_def\_detail.tp\_name***

TP name. This is a 64-byte string, padded on the right with spaces if the name is shorter than 64 characters.

***tp\_def\_detail.tp\_chars.description***

A null-terminated text string describing the TP, as specified in the definition of the TP.

***tp\_def\_detail.tp\_chars.security\_list\_name***

Name of the security access list used by this TP (defined using the `DEFINE_SECURITY_ACCESS_LIST` verb). This parameter restricts the TP so that only the users named in the specified list can allocate conversations with it.

If this parameter is set to 14 binary zeros, the TP is available for use by any user.

***tp\_def\_detail.tp\_chars.conv\_type***

Specifies the type or types of conversation supported by the TP. Possible values are:

**AP\_BASIC**

The TP supports only basic conversations.

**AP\_MAPPED**

The TP supports only mapped conversations.

**AP\_EITHER**

The TP supports either basic or mapped conversations.

***tp\_def\_detail.tp\_chars.security\_rqd***

Specifies the level of conversation security information required to start the TP. Possible values are:

**AP\_YES**

A user ID and password are required to start the TP.

**AP\_NO**

No security information is required.

***tp\_def\_detail.tp\_chars.sync\_level***

Specifies the values of synchronization level supported by the TP. Possible values are:

**AP\_NONE**

The TP supports only `sync_level` NONE.

## QUERY\_TP\_DEFINITION

### **AP\_CONFIRM\_SYNC\_LEVEL**

The TP supports only *sync\_level* CONFIRM.

### **AP\_EITHER**

The TP supports either *sync\_level* NONE or CONFIRM.

### **AP\_SYNCPT\_REQUIRED**

The TP supports only *sync\_level* SYNCPT (syncpoint is required).

### **AP\_SYNCPT\_NEGOTIABLE**

The TP supports any of the three *sync\_level* values NONE, CONFIRM, and SYNCPT.

### ***tp\_def\_detail.tp\_chars.dynamic\_load***

Specifies whether the TP can be dynamically loaded. This is set to AP\_YES.

### ***tp\_def\_detail.tp\_chars.enabled***

Specifies whether the TP can be attached successfully. Possible values are:

#### **AP\_YES**

TP can be attached.

#### **AP\_NO**

TP cannot be attached.

### ***tp\_def\_detail.tp\_chars.pip\_allowed***

Specifies whether the TP can receive Program Initialization Parameters (PIP). Possible values are:

#### **AP\_YES**

TP can receive PIP.

#### **AP\_NO**

TP cannot receive PIP.

### ***tp\_def\_detail.tp\_chars.duplex\_support***

Specifies which conversation duplex types are supported by the TP. Possible values are:

#### **AP\_HALF\_DUPLEX**

The TP supports half-duplex conversations only.

#### **AP\_FULL\_DUPLEX**

The TP supports full-duplex conversations.

#### **AP\_EITHER\_DUPLEX**

The TP supports both half-duplex and full-duplex conversations.

### ***tp\_def\_detail.tp\_chars.tp\_instance\_limit***

Limit on the number of concurrently active TP instances.

### ***tp\_def\_detail.tp\_chars.incoming\_alloc\_timeout***

Specifies the number of seconds that an incoming Attach will be queued waiting for a RECEIVE\_ALLOCATE. The value 0 (zero) implies that there is no timeout; the incoming Attach will be queued indefinitely.

### ***tp\_def\_detail.tp\_chars.rcv\_alloc\_timeout***

Number of seconds that a RECEIVE\_ALLOCATE verb is queued waiting for an incoming Attach. The value 0 (zero) implies that there is no timeout; the RECEIVE\_ALLOCATE verb will be queued indefinitely.

### ***tp\_def\_detail.tp\_chars.tp\_data\_len***

Length of the implementation dependent TP data.

### ***tp\_def\_detail.tp\_chars.tp\_data***

CS/AIX does not use this parameter (it is set to all zeros).

## Returned parameters: parameter check

If the verb does not execute because of a parameter error, CS/AIX returns the following parameters:

### ***primary\_rc***

AP\_PARAMETER\_CHECK

**secondary\_rc**

Possible values are:

**AP\_INVALID\_TP\_NAME**

The *list\_options* parameter was set to AP\_LIST\_INCLUSIVE to list all entries starting from the supplied name, but the *tp\_name* parameter was not valid.

**AP\_INVALID\_LIST\_OPTION**

The *list\_options* parameter was not set to a valid value.

Appendix B, “Common return codes,” on page 661 lists further secondary return codes associated with AP\_PARAMETER\_CHECK, which are common to all NOF verbs.

**Returned parameters: other conditions**

Appendix B, “Common return codes,” on page 661 lists further combinations of primary and secondary return codes that are common to all NOF verbs.

**QUERY\_TP\_LOAD\_INFO**

QUERY\_TP\_LOAD\_INFO returns information about TP load information entries. The buffer contains a number of the variably sized *tp\_load\_info* structures.

This verb must be issued to a running node.

**VCB structure**

```
typedef struct query_tp_load_info
{
    AP_UINT16          opcode;           /* Verb operation code      */
    unsigned char     reserv2;          /* reserved                  */
    unsigned char     format;           /* reserved                  */
    AP_UINT16         primary_rc;       /* Primary return code      */
    AP_UINT32         secondary_rc;     /* Secondary return code    */
    unsigned char     *buf_ptr;         /* pointer to buffer        */
    AP_UINT32         buf_size;         /* buffer size              */
    AP_UINT32         total_buf_size;   /* total buffer size required */
    AP_UINT16         num_entries;      /* number of entries        */
    AP_UINT16         total_num_entries; /* total number of entries  */
    unsigned char     list_options;     /* listing options          */
    unsigned char     reserv3[3];       /* reserved                  */
    unsigned char     tp_name[64];      /* TP name                   */
    unsigned char     lu_alias[8];      /* LU alias                  */
} QUERY_TP_LOAD_INFO;
```

```
typedef struct tp_load_info
{
    AP_UINT16         overlay_size;     /* size of returned entry   */
    unsigned char     tp_name[64];      /* TP name                   */
    unsigned char     lu_alias[8];      /* LU alias                  */
    TP_LOAD_INFO_DEF_DATA def_data;    /* defined data              */
} TP_LOAD_INFO;
```

```
typedef struct tp_load_info_def_data
{
    unsigned char     description[32];  /* Description                */
    unsigned char     reserv1[16];     /* reserved                  */
    unsigned char     user_id[64];     /* User ID                   */
    unsigned char     group_id[64];    /* Group ID                  */
    unsigned short    timeout;         /* Timeout value             */
    unsigned char     type;            /* TP type                   */
    unsigned char     reserv2;         /* reserved                  */
    AP_UINT16         reserv3;         /* reserved                  */
    AP_UINT16         ltv_length;      /* Length of LTV data        */
} TP_LOAD_INFO_DEF_DATA;
```

**Supplied parameters**

The application supplies the following parameters:

**opcode**

AP\_QUERY\_TP\_LOAD\_INFO

**buf\_ptr**

A pointer to a data buffer that CS/AIX will use to return the requested information.

**buf\_size**

Size of the supplied data buffer.

**num\_entries**

Maximum number of extra data control blocks for which data should be returned. To request data for a specific resource rather than a range, specify the value 1. To return as many entries as possible, specify zero; in this case, CS/AIX will return the maximum number of entries that can be accommodated in the supplied data buffer.

**list\_options**

The position in the list of TPs from which CS/AIX should begin to return data. Possible values are:

**AP\_FIRST\_IN\_LIST**

Start at the first entry in the list.

**AP\_LIST\_INCLUSIVE**

Start at the entry specified by the combination of TP name and LU alias.

**AP\_LIST\_FROM\_NEXT**

Start at the entry immediately following the entry specified by the combination of TP name and LU alias.

For more information about how the list is ordered and how the application can obtain specific entries from it, see [“List options for QUERY\\_\\* Verbs”](#) on page 33.

**tp\_name**

TP name to query. This is a 64-byte EBCDIC string, padded on the right with spaces if the name is shorter than 64 characters. Specify all binary zeroes to match on all TPs. This value is ignored if *list\_options* is set to AP\_FIRST\_IN\_LIST.

**lu\_alias**

The LU alias to query. This is an 8-byte ASCII string, padded on the right with spaces if the name is shorter than 8 bytes. Specify all binary zeroes to match on all LUs.

This parameter can be used only if the TP is an APPC application; it is reserved if the TP is a CPI-C application.

## Returned parameters: successful execution

If the verb executes successfully, CS/AIX returns the following parameters:

**primary\_rc**

AP\_OK

**buf\_size**

Length of the information returned in the supplied buffer.

**total\_buf\_size**

Returned value indicating the size of buffer that would have been required to return all the list information requested. A value greater than *buf\_size* indicates that not all the available entries were returned.

**num\_entries**

Number of entries returned in the data buffer.

**total\_num\_entries**

Total number of entries available. A value greater than *num\_entries* indicates that not all the available entries were returned.

Each entry in the data buffer consists of the following parameters:

***tp\_load\_info.overlay\_size***

The size of this overlay, including the LTV data. This size includes padding to ensure that the next overlay falls on a properly aligned memory location.

When your application needs to go through the returned buffer to find each `tp_load_info` structure in turn, it must use this value to move to the correct offset for the next data structure, and must not use the C `sizeof()` operator. This is because the size of the returned overlay may increase in future releases of CS/AIX; using the returned overlay size ensures that your application will continue to work with future releases.

***tp\_load\_info.tp\_name***

TP name of the TP load info entry. This is a 64-byte EBCDIC string, padded on the right with spaces if the name is shorter than 64 characters.

***tp\_load\_info.lu\_alias***

The LU alias of the TP load info entry. This is an 8-byte ASCII string, padded on the right with spaces if the name is shorter than 8 bytes.

This parameter is used only if the TP is an APPC application; it is reserved if the TP is a CPI-C application.

***def\_data.description***

Description of the TP load info.

***def\_data.user\_id***

User ID required to access and run the TP.

***def\_data.group\_id***

Group ID required to access and run the TP.

***def\_data.timeout***

Timeout in seconds after the TP is loaded.

***def\_data.type***

Indicates the TP type. Possible values are:

AP\_TP\_TYPE\_QUEUED

AP\_TP\_TYPE\_QUEUED\_BROADCAST

AP\_TP\_TYPE\_NON\_QUEUED

***def\_data.ltv\_length***

Length of the LTV data buffer appended to this structure.

## Returned parameters: parameter check

If the verb does not execute because of a parameter error, CS/AIX returns the following parameters:

***primary\_rc***

AP\_PARAMETER\_CHECK

***secondary\_rc***

Possible values are:

**AP\_INVALID\_TP\_NAME**

The *tp\_name* parameter did not match the name of a defined TP.

**AP\_INVALID\_LU\_ALIAS**

The *lu\_alias* parameter did not match any defined LU alias.

Appendix B, “Common return codes,” on page 661 lists further secondary return codes associated with AP\_PARAMETER\_CHECK, which are common to all NOF verbs.

## Returned parameters: other conditions

Appendix B, “Common return codes,” on page 661 lists further combinations of primary and secondary return codes that are common to all NOF verbs.

## QUERY\_TRACE\_FILE

This verb returns information about the files that CS/AIX uses to record trace data.

This verb must be issued to a running node.

### VCB structure

```
typedef struct query_trace_file
{
    AP_UINT16      opcode;                /* verb operation code      */
    unsigned char  reserv2;               /* reserved                 */
    unsigned char  format;               /* reserved                 */
    AP_UINT16      primary_rc;           /* primary return code     */
    AP_UINT32      secondary_rc;        /* secondary return code   */
    unsigned char  trace_file_type;     /* type of trace file     */
    unsigned char  dual_files;          /* dual trace files       */
    AP_UINT32      trace_file_size;     /* trace file size        */
    unsigned char  reserv3[4];          /* reserved                 */
    unsigned char  file_name[81];       /* file name               */
    unsigned char  file_name_2[81];    /* second file name       */
} QUERY_TRACE_FILE;
```

### Supplied parameters

The application supplies the following parameters:

#### ***opcode***

AP\_QUERY\_TRACE\_FILE

#### ***trace\_file\_type***

The type of trace file. Possible values are:

##### **AP\_CS\_TRACE**

File contains tracing on data transferred across the CS/AIX LAN between the specified computer and other nodes (activated by the SET\_CS\_TRACE verb).

##### **AP\_TN\_SERVER\_TRACE**

File contains tracing on the CS/AIX TN server component.

##### **AP\_TN3270\_SLP\_TRACE**

File contains tracing on the CS/AIX TN3270 Service Location Protocol component.

##### **AP\_IPS\_TRACE**

File contains tracing on kernel components for the specified node (activated by the SET\_TRACE\_TYPE or ADD\_DLC\_TRACE verb).

### Returned parameters: successful execution

If the verb executes successfully, CS/AIX returns the following parameters:

#### ***primary\_rc***

AP\_OK

#### ***secondary\_rc***

Not used.

#### ***dual\_files***

Specifies whether tracing is to one file or to two files. Possible values are:

##### **AP\_YES**

Tracing is to two files. When the first file reaches the size specified by *trace\_file\_size*, the second file is cleared, and tracing continues to the second file. When this file then reaches the size specified by *trace\_file\_size*, the first file is cleared, and tracing continues to the first file. This ensures that tracing can continue for long periods without using excessive disk space; the maximum space required is approximately twice the value of *trace\_file\_size*.



**AP\_NO**

Tracing is to one file.

**trace\_file\_size**

The maximum size of the trace file. If *dual\_files* is set to AP\_YES, tracing will switch between the two files when the current file reaches this size. If *dual\_files* is set to AP\_NO, this parameter is ignored; the file size is not limited.

**file\_name**

Name of the trace file, or of the first trace file if *dual\_files* is set to AP\_YES. This parameter is an ASCII string of 1-80 characters, followed by a NULL character (binary zero).

If no path is included, the file is stored in the default directory for diagnostics files, `/var/sna` if a path is included, this is either a full path (starting with a `/` character) or the path relative to the default directory.

**file\_name\_2**

Name of the second trace file; this parameter is used only if *dual\_files* is set to AP\_YES. This parameter is an ASCII string of 1-80 characters, followed by a NULL character (binary zero).

If no path is included, the file is stored in the default directory for diagnostics files, `/var/sna` if a path is included, this is either a full path (starting with a `/` character) or the path relative to the default directory.

## Returned parameters: parameter check

If the verb does not execute because of a parameter error, CS/AIX returns the following parameters:

**primary\_rc**

AP\_PARAMETER\_CHECK

**secondary\_rc****AP\_INVALID\_FILE\_TYPE**

The *trace\_file\_type* parameter was not set to a valid value.

Appendix B, “Common return codes,” on page 661 lists further secondary return codes associated with AP\_PARAMETER\_CHECK, which are common to all NOF verbs.

## Returned parameters: other conditions

Appendix B, “Common return codes,” on page 661 lists further combinations of primary and secondary return codes that are common to all NOF verbs.

## QUERY\_TRACE\_TYPE

This verb returns information about the current tracing options for CS/AIX kernel components. For more information about tracing options, see the *IBM Communications Server for Data Center Deployment on AIX Administration Guide*.

This verb does not return information about DLC line tracing. To do this, use the QUERY\_DLC\_TRACE verb.

This verb must be issued to a running node.

## VCB structure

```
typedef struct query_trace_type
{
    AP_UINT16      opcode;          /* verb operation code          */
    unsigned char  reserv2;        /* reserved                     */
    unsigned char  format;        /* reserved                     */
    AP_UINT16      primary_rc;     /* primary return code         */
    AP_UINT32      secondary_rc;   /* secondary return code       */
    AP_UINT16      trace_flags;    /* trace flags                 */
    AP_UINT32      truncation_length; /* truncate each msg to this size */
    AP_UINT16      internal_level; /* reserved                    */
}
```

## QUERY\_TRACE\_TYPE

```
AP_UINT32    api_flags;           /* reserved */
} QUERY_TRACE_TYPE;
```

### Supplied parameters

The application supplies the following parameter:

#### *opcode*

AP\_QUERY\_TRACE\_TYPE

### Returned parameters: successful execution

If the verb executes successfully, CS/AIX returns the following parameters:

#### *primary\_rc*

AP\_OK

#### *secondary\_rc*

Not used.

#### *trace\_flags*

The types of tracing currently active. For more information about these trace types, see [“SET\\_TRACE\\_TYPE” on page 579](#).

If no tracing is active, or if tracing of all types is active, this is one of the following values:

#### **AP\_NO\_TRACE**

No tracing.

#### **AP\_ALL\_TRACE**

Tracing of all types.

If tracing is being used on specific interfaces, this parameter is set to one or more values from the list below, combined using a logical OR operation.

#### **AP\_APPC\_MSG**

APPC messages

#### **AP\_FM\_MSG**

FM messages

#### **AP\_LUA\_MSG**

LUA messages

#### **AP\_NOF\_MSG**

NOF messages

#### **AP\_MS\_MSG**

MS messages

#### **AP\_GSNA\_MSG**

Generic SNA messages

#### **AP\_PV\_MSG**

(not used in this version of CS/AIX)

#### **AP\_GDLC\_MSG**

GDLC messages

#### **AP\_IPDL\_MSG**

Enterprise Extender (HPR/IP) messages

#### **AP\_DLC\_MSG**

Node to DLC messages

#### **AP\_NODE\_MSG**

Node messages

#### **AP\_SLIM\_MSG**

Messages sent between controller and backup servers in a client/server system

**AP\_DATAGRAM**

Datagram messages

**truncation\_length**

The maximum length, in bytes, of the information written to the trace file for each message. If a message is longer than this, CS/AIX writes only the start of the message to the trace file, and discards the data beyond *truncation\_length*. This allows you to record the most important information for each message but avoid filling up the file with long messages. A value of zero indicates that trace messages are not truncated.

**Returned parameters: other conditions**

Appendix B, “Common return codes,” on page 661 lists further combinations of primary and secondary return codes that are common to all NOF verbs.

**QUERY\_USERID\_PASSWORD**

QUERY\_USERID\_PASSWORD returns information about user ID / password pairs for use with APPC and CPI-C conversation security, or about profiles for a defined user ID and password. It can be used to obtain information about a specific user ID / password pair or about multiple pairs, depending on the options used.

**VCB structure**

```
typedef struct query_userid_password
{
    AP_UINT16      opcode;           /* Verb operation code      */
    unsigned char  reserv2;         /* reserved                 */
    unsigned char  format;         /* reserved                 */
    AP_UINT16      primary_rc;     /* Primary return code     */
    AP_UINT32      secondary_rc;   /* Secondary return code   */
    unsigned char  *buf_ptr;       /* pointer to buffer       */
    AP_UINT32      buf_size;       /* buffer size             */
    AP_UINT32      total_buf_size; /* total buffer size required */
    AP_UINT16      num_entries;    /* number of entries       */
    AP_UINT16      total_num_entries; /* total number of entries */
    unsigned char  list_options;   /* listing options         */
    unsigned char  reserv3;       /* reserved                 */
    unsigned char  user_id[10];    /* user ID                 */
} QUERY_USERID_PASSWORD;
```

```
typedef struct userid_info
{
    AP_UINT16      overlay_size;    /* size of returned entry  */
    unsigned char  user_id[10];    /* user ID                 */
    USERID_PASSWORD_CHARS password_chars; /* password characteristics */
} USERID_INFO;
```

```
typedef struct userid_password_chars
{
    unsigned char  description[32]; /* resource description    */
    unsigned char  reserv2[16];    /* reserved                 */
    AP_UINT16      profile_count;  /* number of profiles     */
    AP_UINT16      reserv1;       /* reserved                 */
    unsigned char  password[10];  /* password                 */
    unsigned char  profiles[10][10]; /* profiles                 */
} USERID_PASSWORD_CHARS;
```

**Supplied parameters**

The application supplies the following parameters:

**opcode**

AP\_QUERY\_USERID\_PASSWORD

**buf\_ptr**

A pointer to a data buffer that CS/AIX will use to return the requested information.

### ***buf\_size***

Size of the supplied data buffer.

### ***num\_entries***

Maximum number of user ID / password pairs for which data should be returned. To request a specific entry rather than a range, specify the value 1. To return as many entries as possible, specify zero; in this case, CS/AIX will return the maximum number of entries that can be accommodated in the supplied data buffer.

### ***list\_options***

The position in the list from which CS/AIX should begin to return data. Specify one of the following values:

#### **AP\_FIRST\_IN\_LIST**

Start at the first entry in the list.

#### **AP\_LIST\_INCLUSIVE**

Start at the entry specified by the *user\_id* parameter.

#### **AP\_LIST\_FROM\_NEXT**

Start at the entry immediately following the entry specified by the *user\_id* parameter.

For more information about how the list is ordered and how the application can obtain specific entries from it, see [“List options for QUERY\\_\\* Verbs”](#) on page 33.

### ***user\_id***

User ID. This is a 10-byte type-AE EBCDIC string, padded on the right with spaces if the name is shorter than 10 characters. The user ID is ignored if *list\_options* is set to AP\_FIRST\_IN\_LIST.

## Returned parameters: successful execution

If the verb executes successfully, CS/AIX returns the following parameters:

### ***primary\_rc***

AP\_OK

### ***buf\_size***

Length of the information returned in the supplied buffer.

### ***total\_buf\_size***

Returned value indicating the size of buffer that would have been required to return all the list information requested. A value greater than *buf\_size* indicates that not all the available entries were returned.

### ***num\_entries***

Number of entries returned in the data buffer.

### ***total\_num\_entries***

Total number of entries available. A value greater than *num\_entries* indicates that not all the available entries were returned.

Each entry in the data buffer consists of the following parameters:

### ***userid\_info.overlay\_size***

The size of the returned *userid\_info* structure, and therefore the offset to the start of the next entry in the data buffer.

When your application needs to go through the returned buffer to find each *userid\_info* structure in turn, it must use this value to move to the correct offset for the next data structure, and must not use the C `sizeof()` operator. This is because the size of the returned overlay may increase in future releases of CS/AIX; using the returned overlay size ensures that your application will continue to work with future releases.

### ***userid\_info.user\_id***

User identifier. This is a 10-byte type-AE EBCDIC character string, padded on the right with EBCDIC spaces.

***userid\_info.password\_chars.description***

A null-terminated text string describing the user ID and password, as specified in the definition of the user ID and password.

***userid\_info.password\_chars.profile\_count***

Number of profiles defined for this user.

***userid\_info.password\_chars.password***

An encrypted version of the user's password supplied on a DEFINE\_USERID\_PASSWORD verb. This is a 10-byte type-AE EBCDIC character string, padded on the right with EBCDIC spaces.

***userid\_info.password\_chars.profiles***

Profiles associated with user. Each of these is a 10-byte type-AE EBCDIC character string, padded on the right with EBCDIC spaces.

## Returned parameters: parameter check

If the verb does not execute because of a parameter error, CS/AIX returns the following parameters:

***primary\_rc***

AP\_PARAMETER\_CHECK

***secondary\_rc***

Possible values are:

**AP\_INVALID\_USERID**

The *list\_options* parameter was set to AP\_LIST\_INCLUSIVE to list all entries starting from the supplied user ID, but the *user\_id* parameter was not valid.

**AP\_INVALID\_LIST\_OPTION**

The *list\_options* parameter was not set to a valid value.

Appendix B, “Common return codes,” on page 661 lists further secondary return codes associated with AP\_PARAMETER\_CHECK, which are common to all NOF verbs.

## Returned parameters: other conditions

Appendix B, “Common return codes,” on page 661 lists further combinations of primary and secondary return codes that are common to all NOF verbs.

## REGISTER\_INDICATION\_SINK

---

REGISTER\_INDICATION\_SINK registers the NOF application to receive indications of a particular type; for details of the CS/AIX NOF indications, see Chapter 4, “NOF Indications,” on page 599. The application specifies the required type of indication by its *opcode* parameter; an application can register more than once to accept multiple indication types. Each time an event occurs for which the application has requested indications (for example a change in the configuration of the application's target node or a change in the status of a DLC), CS/AIX sends the appropriate indication message to the application.

A NOF\_STATUS\_INDICATION, which indicates status changes for the target node or file, may be returned to an application that has registered for any type of indication. For more information, see “NOF\_STATUS\_INDICATION” on page 632.

This verb must always be issued using the asynchronous NOF API entry point, including a callback routine (for more information about the NOF API entry points, see “Asynchronous entry point: nof\_async” on page 21). CS/AIX uses this callback routine to return the requested indications to the application.

This verb may be issued to different targets depending on the type of indications required, as follows:

- To register for SNA network file indications, the target must be the `sna.net` file.
- To register for server indications, no target is required; the application must specify a null target handle.
- To register for configuration indications relating to domain resources, the target must be the domain configuration file.

## REGISTER\_INDICATION\_SINK

- To register for configuration indications relating to node resources, or to register for any other indications, the target may be either a running node or an inactive node on a computer where the CS/AIX software is running.

## VCB structure

```
typedef struct register_indication_sink
{
    AP_UINT16      opcode;          /* verb operation code          */
    unsigned char  reserv2;        /* reserved                      */
    unsigned char  format;        /* reserved                      */
    AP_UINT16      primary_rc;     /* primary return code          */
    AP_UINT32      secondary_rc;   /* secondary return code        */
    AP_UINT32      proc_id;        /* reserved                      */
    AP_UINT16      queue_id;       /* reserved                      */
    AP_UINT16      indication_opcode; /* opcode of indication to be sunk */
} REGISTER_INDICATION_SINK;
```

## Supplied parameters

The application supplies the following parameters:

### *opcode*

AP\_REGISTER\_INDICATION\_SINK

### *indication\_opcode*

The *opcode* parameter of the indication to be returned. CS/AIX will send this indication to the application's callback routine every time the indication is generated.

To receive configuration indications, specify the value AP\_CONFIG\_INDICATION. If the target handle specified on the REGISTER\_INDICATION\_SINK verb identifies the domain configuration file, this value requests an indication each time the file is updated; if the target handle identifies a node, this value requests an indication each time the node's configuration is updated.

To receive SNA network file indications, issue the verb using a target handle that identifies the sna.net file, and specify the value AP\_SNA\_NET\_INDICATION. This value requests an indication each time the file is updated.

For all other indications, specify the *opcode* value for the required indication. For more information, see the descriptions of individual indications in [Chapter 4, "NOF Indications,"](#) on page 599.

## Returned parameters: successful execution

If the verb executes successfully, CS/AIX returns the following parameters:

### *primary\_rc*

AP\_OK

### *secondary\_rc*

Not used.

## Returned parameters: parameter check

If the verb does not execute because of a parameter error, CS/AIX returns the following parameters:

### *primary\_rc*

AP\_PARAMETER\_CHECK

### *secondary\_rc*

Possible values are:

#### **AP\_INVALID\_OP\_CODE**

One of the following has occurred:

- The *indication\_opcode* parameter did not match the *opcode* of any of the CS/AIX NOF API indications.

- The *indication\_opcode* parameter specified an indication type that does not apply to the specified target. If the target handle identifies the domain configuration file, only configuration indications are valid; if the target handle identifies the *sna.net* file, only SNA network file indications are valid; and if the target handle specifies a running node, all indications except SNA network file indications are valid.

**AP\_DYNAMIC\_LOAD\_ALREADY\_REGD**

The *indication\_opcode* parameter was set to a reserved value.

**AP\_SYNC\_NOT\_ALLOWED**

The application issued REGISTER\_INDICATION\_SINK using the synchronous NOF entry point. This verb must use the asynchronous entry point.

Appendix B, “Common return codes,” on page 661 lists further secondary return codes associated with AP\_PARAMETER\_CHECK, which are common to all NOF verbs.

**Returned parameters: function not supported**

If the verb does not execute successfully because the local node does not support the function associated with the specified indication, CS/AIX returns the following parameters:

***primary\_rc*****AP\_FUNCTION\_NOT\_SUPPORTED**

The local node does not support the specified indication. For details of the support required for each indication, see the description of each indication in Chapter 4, “NOF Indications,” on page 599.

**Returned parameters: other conditions**

Appendix B, “Common return codes,” on page 661 lists further combinations of primary and secondary return codes that are common to all NOF verbs.

**REMOVE\_DLC\_TRACE**

This verb removes DLC line tracing that was previously specified using ADD\_DLC\_TRACE. It can be used to remove all tracing on a resource that is currently being traced, to remove the tracing of certain messages from a resource currently being traced, or to remove all DLC line tracing.

**VCB structure**

```
typedef struct remove_dlc_trace
{
    AP_UINT16      opcode;                /* verb operation code      */
    unsigned char  reserv2;               /* reserved                  */
    unsigned char  format;               /* reserved                  */
    AP_UINT16      primary_rc;           /* primary return code      */
    AP_UINT32      secondary_rc;        /* secondary return code    */
    DLC_TRACE_FILTER filter;            /* resource to stop tracing */
} REMOVE_DLC_TRACE;
```

```
typedef struct dlc_trace_filter
{
    unsigned char  resource_type;         /* type of resource         */
    unsigned char  resource_name[8];     /* name of resource         */
    SNA_LFSID      lfsid;                /* session identifier       */
    unsigned char  message_type;        /* type of messages        */
} DLC_TRACE_FILTER;
```

```
typedef struct sna_lfsid
{
    union
    {
        AP_UINT16      session_id;
        struct
        {

```

## REMOVE\_DLC\_TRACE

```
        unsigned char    sidh;
        unsigned char    sidl;
    } s;
} uu;
AP_UINT16            odai;
} SNA_LFSID;
```

## Supplied parameters

The application supplies the following parameters:

### **opcode**

AP\_REMOVE\_DLC\_TRACE

### **resource\_type**

The resource type of the trace entry to remove or modify. Possible values are:

#### **AP\_ALL\_DLC\_TRACES**

Remove all DLC tracing options, so that no resources are traced. If this option is specified, the remaining parameters on this verb (*resource\_name* through *message\_type*) are reserved.

#### **AP\_ALL\_RESOURCES**

Remove or modify the tracing options used for tracing all DLCs, ports, and LSs; resources for which DLC\_TRACE entries are explicitly defined will continue to be traced.

#### **AP\_DLC**

Remove or modify tracing for the DLC named in *resource\_name*, and for all ports and LSs that use this DLC.

#### **AP\_PORT**

Remove or modify tracing for the port named in *resource\_name*, and for all LSs that use this port.

#### **AP\_LS**

Remove or modify tracing for the LS named in *resource\_name*.

#### **AP\_RTP**

Remove or modify tracing for the RTP (rapid transport protocol) connection named in *resource\_name*.

#### **AP\_PORT\_DEFINED\_LS**

Modify tracing for the port named in *resource\_name* and its defined LSs.

#### **AP\_PORT\_IMPLICIT\_LS**

Modify tracing for the port named in *resource\_name* and its implicit LSs.

### **resource\_name**

The name of the DLC, port, LS, or RTP connection for which tracing is being removed or modified. This parameter is reserved if *resource\_type* is set to AP\_ALL\_DLC\_TRACES or AP\_ALL\_RESOURCES.

### **lfsid**

The Local Form Session Identifier for a session on the specified LS. This is only valid for *resource\_type* AP\_LS, and indicates that only messages on this session are to be removed. The structure contains the following three values, which are returned in the SESSION\_STATS section of a QUERY\_SESSION verb:

#### **lfsid.uu.s.sidh**

Session ID high byte.

#### **lfsid.uu.s.sidl**

Session ID low byte.

#### **lfsid.odai**

Origin Destination Assignor Indicator.

### **message\_type**

The type of messages to trace for the specified resource or session. Set this parameter to AP\_TRACE\_ALL to remove all messages, or specify one or more of the following values (combined using a logical OR):



**AP\_TRACE\_XID**

XID messages

**AP\_TRACE\_SC**

Session Control RUs

**AP\_TRACE\_DFC**

Data Flow Control RUs

**AP\_TRACE\_FMD**

FMD messages

**AP\_TRACE\_SEGS**

Non-BBIU segments that do not contain an RH

**AP\_TRACE\_CTL**

Messages other than MUs and XIDs

**AP\_TRACE\_NLP**

(this message type is currently not used)

**AP\_TRACE\_NC**

(this message type is currently not used)

For tracing on an RTP connection, the values AP\_TRACE\_XID, AP\_TRACE\_NLP, and AP\_TRACE\_CTL are ignored.

## Returned parameters: successful execution

If the verb executes successfully, CS/AIX returns the following parameters:

***primary\_rc***

AP\_OK

***secondary\_rc***

Not used.

## Returned parameters: parameter check

If the verb does not execute because of a parameter error, CS/AIX returns one of the following.

***primary\_rc***

AP\_PARAMETER\_CHECK

***secondary\_rc***

Possible values are:

**AP\_INVALID\_RESOURCE\_TYPE**The *resource\_type* parameter specified a value that was not valid.**AP\_INVALID\_MESSAGE\_TYPE**The *message\_type* parameter specified a value that was not valid.**AP\_INVALID\_DLC\_NAME**The DLC named in *resource\_name* does not have any tracing options set.**AP\_INVALID\_PORT\_NAME**The Port named in *resource\_name* does not have any tracing options set.**AP\_INVALID\_LS\_NAME**The LS named in *resource\_name* does not have any tracing options set.**AP\_INVALID\_RTP\_CONNECTION**The RTP connection named in the *resource\_name* parameter does not have any tracing options set.**AP\_INVALID\_LFSID\_SPECIFIED**The LS named in *resource\_name* does not have any tracing options set for the specified LFSID.

## RESET\_SESSION\_LIMIT

### AP\_INVALID\_FILTER\_TYPE

The *message\_type* parameter specified a message type that is not currently being traced for the specified resource.

### AP\_ALL\_RESOURCES\_NOT\_DEFINED

The *resource\_type* parameter was set to AP\_ALL\_RESOURCES, but there is no DLC\_TRACE entry defined for tracing options on all resources.

Appendix B, “Common return codes,” on page 661 lists further secondary return codes associated with AP\_PARAMETER\_CHECK, which are common to all NOF verbs.

## Returned parameters: other conditions

Appendix B, “Common return codes,” on page 661 lists further combinations of primary and secondary return codes that are common to all NOF verbs.

## RESET\_SESSION\_LIMIT

The RESET\_SESSION\_LIMIT verb requests CS/AIX to reset the session limits for a particular LU-LU-mode combination. Sessions may be deactivated as a result of processing this verb.

## VCB structure

```
typedef struct reset_session_limit
{
    AP_UINT16      opcode;                /* verb operation code          */
    unsigned char  reserv2;               /* reserved                      */
    unsigned char  format;                /* reserved                      */
    AP_UINT16      primary_rc;            /* primary return code          */
    AP_UINT32      secondary_rc;          /* secondary return code        */
    unsigned char  lu_name[8];            /* local LU name                 */
    unsigned char  lu_alias[8];           /* local LU alias                */
    unsigned char  plu_alias[8];          /* partner LU alias              */
    unsigned char  fqplu_name[17];        /* fully qualified partner LU name*/
    unsigned char  reserv3;               /* reserved                      */
    unsigned char  mode_name[8];          /* mode name                     */
    unsigned char  mode_name_select;      /* select mode name              */
    unsigned char  set_negotiable;        /* set max negotiable limit to  */
                                          /* zero?                          */
    unsigned char  reserv4[8];            /* reserved                      */
    unsigned char  responsible;           /* who is responsible for        */
                                          /* deactivation                  */
    unsigned char  drain_source;          /* drain source                  */
    unsigned char  drain_target;          /* drain target                  */
    unsigned char  force;                 /* force                         */
    AP_UINT32      sense_data;            /* sense data                    */
} RESET_SESSION_LIMIT;
```

## Supplied parameters

The application supplies the following parameters:

### *opcode*

AP\_RESET\_SESSION\_LIMIT

### *lu\_name*

LU name of the local LU, as defined to CS/AIX. This is an 8-byte type-A EBCDIC string, padded on the right with spaces if the name is shorter than 8 bytes. To indicate that the LU is defined by its LU alias instead of its LU name, set this parameter to 8 binary zeros.

### *lu\_alias*

LU alias of the local LU, as defined to CS/AIX. This is an 8-byte ASCII string, using any locally displayable characters, padded on the right with spaces if the name is shorter than 8 bytes. It is used only if *lu\_name* is set to zeros.

To indicate the LU associated with the CP (the default LU), set both *lu\_name* and *lu\_alias* to 8 binary zeros.

***plu\_alias***

LU alias of the partner LU.

This is an 8-byte ASCII string, using any locally displayable characters, padded on the right with spaces if the name is shorter than 8 bytes. To indicate that the partner LU is defined by its fully qualified LU name instead of its LU alias, set this parameter to 8 binary zeros.

***fqplu\_name***

Fully qualified LU name for the partner LU, as defined to CS/AIX. This parameter is used only if the *plu\_alias* field is set to zeros; it is ignored if *plu\_alias* is specified.

The name is a 17-byte EBCDIC string, right-padded with EBCDIC spaces. It consists of a network ID of up to 8 A-string characters, an EBCDIC dot (period) character, and a network name of up to 8 A-string characters.

***mode\_name***

Name of the mode for which to reset session limits. This parameter is ignored if *mode\_name\_select* is set to AP\_ALL.

This is an 8-byte alphanumeric type-A EBCDIC string (starting with a letter), padded on the right with EBCDIC spaces if the name is shorter than 8 bytes.

***mode\_name\_select***

Selects whether session limits should be reset on a single specified mode, or on all modes between the local and partner LUs. Possible values are:

**AP\_ONE**

Reset session limits on the mode specified by *mode\_name*.

**AP\_ALL**

Reset session limits on all modes.

***set\_negotiable***

Specifies whether the maximum negotiable session limit for this LU-LU-mode combination should be reset to zero. (The current limit may be the limit specified for the mode, or may have been changed by *initialize\_session\_limit* or *change\_session\_limit*). Possible values are:

**AP\_YES**

Reset the maximum negotiable session limit for this LU-LU-mode combination to zero so that sessions cannot be activated until it is changed by INITIALIZE\_SESSION\_LIMIT.

**AP\_NO**

Leave the maximum negotiable session limit unchanged.

***responsible***

Indicates whether the source (local) or target (partner) LU is responsible for deactivating sessions after the session limit is reset. Possible values are:

**AP\_SOURCE**

The local LU is responsible for deactivating sessions.

**AP\_TARGET**

The partner LU is responsible for deactivating sessions.

***drain\_source***

Specifies whether the source LU satisfies waiting session requests before deactivating a session. Possible values are:

**AP\_YES**

Waiting session requests are satisfied.

**AP\_NO**

Waiting session requests are not satisfied.

***drain\_target***

Specifies whether the target LU satisfies waiting session requests before deactivating a session. Possible values are:

## RESET\_SESSION\_LIMIT

### **AP\_YES**

Waiting session requests are satisfied.

### **AP\_NO**

Waiting session requests are not satisfied.

### **force**

Specifies whether session limits will be set to zero even if CNOS negotiation fails. Possible values are:

### **AP\_YES**

Session limits will be set to zero.

### **AP\_NO**

Session limits will not be set to zero if CNOS negotiation fails.

## Returned parameters: successful execution

If the verb executes successfully, CS/AIX returns the following parameters:

### **primary\_rc**

AP\_OK

### **secondary\_rc**

Possible values are:

### **AP\_FORCED**

The session limits were set to zero even though CNOS negotiation failed.

### **AP\_AS\_NEGOTIATED**

The session limits were changed, but one or more values were negotiated by the partner LU.

### **AP\_AS\_SPECIFIED**

The session limits were changed as requested, without being negotiated by the partner LU.

## Returned parameters: parameter check

If the verb does not execute because of a parameter error, CS/AIX returns the following parameters:

### **primary\_rc**

AP\_PARAMETER\_CHECK

### **secondary\_rc**

Possible values are:

### **AP\_EXCEEDS\_MAX\_ALLOWED**

A CS/AIX internal error occurred.

### **AP\_INVALID\_LU\_ALIAS**

The *lu\_alias* parameter did not match any defined local LU alias.

### **AP\_INVALID\_LU\_NAME**

The *lu\_name* parameter did not match any defined local LU name.

### **AP\_INVALID\_MODE\_NAME**

The *mode\_name* parameter did not match any defined mode name.

### **AP\_INVALID\_PLU\_NAME**

The *fqplu\_name* parameter did not match any defined partner LU name.

### **AP\_INVALID\_MODE\_NAME\_SELECT**

The *mode\_name\_select* parameter was not set to a valid value.

### **AP\_INVALID\_DRAIN\_SOURCE**

The *drain\_source* parameter was not set to a valid value.

### **AP\_INVALID\_DRAIN\_TARGET**

The *drain\_target* parameter was not set to a valid value.

### **AP\_INVALID\_FORCE**

The *force* parameter was not set to a valid value.

**AP\_INVALID\_RESPONSIBLE**

The *responsible* parameter was not set to a valid value.

**AP\_INVALID\_SET\_NEGOTIABLE**

The *set\_negotiable* parameter was not set to a valid value.

Appendix B, “Common return codes,” on page 661 lists further secondary return codes associated with AP\_PARAMETER\_CHECK, which are common to all NOF verbs.

**Returned parameters: state check**

If the verb does not execute because of a state error, CS/AIX returns the following parameters.

***primary\_rc***

AP\_STATE\_CHECK

***secondary\_rc*****AP\_MODE\_RESET**

No sessions are currently active for this LU-LU-mode combination. Use INITIALIZE\_SESSION\_LIMIT instead of RESET\_SESSION\_LIMIT to specify the limits.

Appendix B, “Common return codes,” on page 661 lists further secondary return codes associated with AP\_STATE\_CHECK, which are common to all NOF verbs.

**Returned parameters: session allocation error**

If the verb does not execute because of a session allocation error, CS/AIX returns the following parameters:

***primary\_rc***

AP\_ALLOCATION\_ERROR

***secondary\_rc*****AP\_ALLOCATION\_FAILURE\_NO\_RETRY**

A session could not be allocated because of a condition that requires corrective action. Check the *sense\_data* parameter and any logged messages to determine the reason for the failure, and take any action required. Do not attempt to retry the verb until the condition has been corrected.

***sense\_data***

The SNA sense data associated with the allocation failure.

**Returned parameters: CNOS processing errors**

If the verb does not execute because of an error, CS/AIX returns the following parameters.

***primary\_rc*****AP\_CONV\_FAILURE\_NO\_RETRY**

The session limits could not be changed because of a condition that requires action (such as a configuration mismatch or a session protocol error). Check the CS/AIX log file for information about the error condition, and correct it before retrying this verb.

***primary\_rc*****AP\_CNOS\_PARTNER\_LU\_REJECT**

The verb failed because CS/AIX failed to negotiate the session limits with the partner. Check configuration at both the local LU and partner LU.

***secondary\_rc*****AP\_CNOS\_COMMAND\_RACE\_REJECT**

The verb failed because the specified mode was being accessed by another administration program (or internally by the CS/AIX software) for session activation or deactivation, or for session limit processing. The application should retry the verb, preferably after a timeout to allow the race condition to be cleared.

## SET\_BUFFER\_AVAILABILITY

### Returned parameters: other conditions

Appendix B, “Common return codes,” on page 661 lists further combinations of primary and secondary return codes that are common to all NOF verbs.

## SET\_BUFFER\_AVAILABILITY

---

This verb specifies the amount of STREAMS buffers that CS/AIX can use at any one time. This allows the node to make efficient use of the buffers available, and allows you to ensure that buffers are available for other processes on the AIX computer.

### VCB structure

```
typedef struct set_buffer_availability
{
    AP_UINT16      opcode;           /* verb operation code      */
    unsigned char  reserv2;         /* reserved                  */
    unsigned char  format;          /* reserved                  */
    AP_UINT16      primary_rc;      /* primary return code      */
    AP_UINT32      secondary_rc;    /* secondary return code    */
    AP_UINT32      buf_avail;       /* maximum buffer space available */
    unsigned char  reserv3[8];      /* reserved                  */
} SET_BUFFER_AVAILABILITY;
```

### Supplied parameters

The application supplies the following parameters:

#### *opcode*

AP\_SET\_BUFFER\_AVAILABILITY

#### *buf\_avail*

The maximum amount of STREAMS buffer space available, in bytes.

### Returned parameters: successful execution

If the verb executes successfully, CS/AIX returns the following parameters:

#### *primary\_rc*

AP\_OK

#### *secondary\_rc*

Not used.

### Returned parameters: other conditions

Appendix B, “Common return codes,” on page 661 lists further combinations of primary and secondary return codes that are common to all NOF verbs.

## SET\_CENTRAL\_LOGGING

---

This verb specifies whether CS/AIX log messages are sent to a central file from all servers, or to a separate file on each server. For more information, see “SET\_LOG\_FILE” on page 568.

This verb must be issued to the node that is currently acting as the central logger; for information about accessing this node, see “CONNECT\_NODE” on page 51.

### VCB structure

```
typedef struct set_central_logging
{
    AP_UINT16      opcode;           /* verb operation code      */
    unsigned char  reserv2;         /* reserved                  */
    unsigned char  format;          /* reserved                  */
}
```

```

AP_UINT16      primary_rc;          /* primary return code */
AP_UINT32      secondary_rc;       /* secondary return code */
unsigned char  enabled;            /* is central logging enabled? */
unsigned char  reserv3[3];         /* reserved */
} SET_CENTRAL_LOGGING;

```

## Supplied parameters

The application supplies the following parameters:

### **opcode**

AP\_SET\_CENTRAL\_LOGGING

### **enabled**

Specify whether central logging is enabled or disabled. Possible values are:

#### **AP\_YES**

Central logging is enabled. All log messages are sent to a single file on the node currently acting as the central logger.

#### **AP\_NO**

Central logging is disabled. Log messages from each server are sent to a file on that server (specified using the SET\_LOG\_FILE verb).

## Returned parameters: successful execution

If the verb executes successfully, CS/AIX returns the following parameters:

### **primary\_rc**

AP\_OK

### **secondary\_rc**

Not used.

## Returned parameters: parameter check

If the verb does not execute because of a parameter error, CS/AIX returns the following parameters:

### **primary\_rc**

AP\_PARAMETER\_CHECK

### **secondary\_rc**

#### **AP\_NOT\_CENTRAL\_LOGGER**

The verb was issued to a node that is not the central logger.

## Returned parameters: other conditions

Appendix B, “Common return codes,” on page 661 lists further combinations of primary and secondary return codes that are common to all NOF verbs.

## SET\_CS\_TRACE

This verb specifies tracing options for data sent between computers on the CS/AIX LAN. For more information about tracing options, see the *IBM Communications Server for Data Center Deployment on AIX Administration Guide*.

This verb can be issued from a NOF application running on an AIX or Linux client. The NOF application must run with the userid `root`, or with a userid that is a member of the `sys` group (AIX) or `sna` group (Linux).

This verb must be issued to a running node, unless it is issued from a client.

## VCB structure

```
typedef struct set_cs_trace
{
    AP_UINT16      opcode;           /* verb operation code          */
    unsigned char  reserv2;         /* reserved                     */
    unsigned char  format;         /* reserved                     */
    AP_UINT16      primary_rc;     /* primary return code         */
    AP_UINT32      secondary_rc;   /* secondary return code       */
    unsigned char  dest_sys[128];  /* node to which messages are traced */
    unsigned char  reserv4[4];     /* reserved                    */
    AP_UINT16      trace_flags;    /* trace flags                 */
    AP_UINT16      trace_direction; /* direction (send/rcv/both) to trace */
    unsigned char  reserv3[8];     /* reserved                    */
} SET_CS_TRACE;
```

## Supplied parameters

The application supplies the following parameters:

### ***opcode***

AP\_SET\_CS\_TRACE

### ***dest\_sys***

The server name for which tracing is required. This is an ASCII string, padded on the right with spaces if the name is shorter than 128 characters.

To manage tracing on messages flowing between the computer to which this verb is issued (identified by the *target\_handle* parameter on the NOF API call) and one other server on the LAN, specify the name of the other server here. Tracing on messages flowing to and from other computers on the LAN will be unchanged; in particular, you can issue two SET\_CS\_TRACE verbs to activate tracing between the same target computer and two different destination servers.

If the server name includes a . (period) character, CS/AIX assumes that it is a fully-qualified name; otherwise it performs a DNS lookup to determine the server name.

To manage tracing on messages flowing between the computer to which this verb is issued (identified by the *target\_handle* parameter on the NOF API call) and all other servers and clients on the LAN, set this parameter to 128 ASCII space characters. The options you specify on this verb override any previous settings for tracing to specific computers (identified by *dest\_sys* on the previous verbs).

### ***trace\_flags***

The types of tracing required. To turn off all tracing, or to turn on tracing of all types, specify one of the following values:

#### **AP\_NO\_TRACE**

No tracing.

#### **AP\_ALL\_TRACE**

Tracing of all types.

To activate tracing on specific message types, select one or more values from the list below, combined using a logical OR operation.

#### **AP\_CS\_ADMIN\_MSG**

Internal messages relating to client/server topology

#### **AP\_CS\_DATAGRAM**

Datagram messages

#### **AP\_CS\_DATA**

Data messages

### ***trace\_direction***

Specifies the direction(s) in which tracing is required. This parameter is ignored if *trace\_flags* is set to AP\_NO\_TRACE. Possible values are:

#### **AP\_CS\_SEND**

Trace messages flowing from the target computer to the computer defined by *dest\_sys*.



**AP\_CS\_RECEIVE**

Trace messages flowing from the computer defined by *dest\_sys* to the target computer.

**AP\_CS\_BOTH**

Trace messages flowing in both directions.

**Returned parameters: successful execution**

If the verb executes successfully, CS/AIX returns the following parameters:

***primary\_rc***

AP\_OK

***secondary\_rc***

Not used.

**Returned parameters: parameter check**

If the verb does not execute because of a parameter error, CS/AIX returns the following parameters:

***primary\_rc***

AP\_PARAMETER\_CHECK

***secondary\_rc***

Possible values are:

**AP\_NAME\_NOT\_FOUND**

The server specified by the *dest\_sys* parameter did not exist or was not started.

**AP\_LOCAL\_SYSTEM**

The server specified by the *dest\_sys* parameter is the same as the target node to which this verb was issued.

**AP\_INVALID\_TRC\_DIRECTION**

The *trace\_direction* parameter was not set to a valid value.

**AP\_INVALID\_TARGET**

The verb was issued on a standalone server. This verb can only be issued on a client/server system.

Appendix B, “Common return codes,” on page 661 lists further secondary return codes associated with AP\_PARAMETER\_CHECK, which are common to all NOF verbs.

**Returned parameters: other conditions**

Appendix B, “Common return codes,” on page 661 lists further combinations of primary and secondary return codes that are common to all NOF verbs.

**SET\_GLOBAL\_LOG\_TYPE**

This verb specifies the types of information that CS/AIX records in log files. It specifies default values that are used on all servers; SET\_LOG\_TYPE can then be used to override these defaults on a particular server. For more information about log files, see “SET\_LOG\_FILE” on page 568.

CS/AIX logs messages for the following types of event:

**Problem**

An abnormal event that degrades the system in a way perceptible to a user (such as abnormal termination of a session).

**Exception**

An abnormal event that degrades the system but that is not immediately perceptible to a user (such as a resource shortage), or an event that does not degrade the system but may indicate the cause of later exceptions or problems (such as receiving an unexpected message from the remote system).

## SET\_GLOBAL\_LOG\_TYPE

### Audit

A normal event (such as starting a session).

Problem and exception messages are logged to the error log file; audit messages are logged to the audit log file. Problem messages are always logged and cannot be disabled, but you can specify whether to log each of the other two message types. For each of the two files (audit and error), you can specify whether to use succinct logging (including only the text of the message and a summary of the message source) or full logging (including full details of the message source, cause, and any action required).

This verb must be issued to the node currently acting as the central logger; for more information, see [“CONNECT\\_NODE”](#) on page 51.

## VCB structure

```
typedef struct set_global_log_type
{
    AP_UINT16      opcode;           /* verb operation code          */
    unsigned char  reserv2;         /* reserved                     */
    unsigned char  format;         /* reserved                     */
    AP_UINT16      primary_rc;      /* primary return code          */
    AP_UINT32      secondary_rc;    /* secondary return code        */
    unsigned char  audit;          /* audit logging on or off      */
    unsigned char  exception;      /* exception logging on or off  */
    unsigned char  succinct_audits; /* use succinct logging in audit file? */
    unsigned char  succinct_errors; /* use succinct logging in error file? */
    unsigned char  reserv3[4];     /* reserved                     */
} SET_GLOBAL_LOG_TYPE;
```

## Supplied parameters

The application supplies the following parameters:

### *opcode*

AP\_SET\_GLOBAL\_LOG\_TYPE

### *audit*

Specify whether audit messages are recorded. Possible values are:

#### **AP\_YES**

Audit messages are recorded.

#### **AP\_NO**

Audit messages are not recorded.

#### **AP\_LEAVE\_UNCHANGED**

Leave audit logging unchanged from the existing definition. (The initial default, when the CS/AIX software is started, is that audit messages are not recorded.)

### *exception*

Specify whether exception messages are recorded. Possible values are:

#### **AP\_YES**

Exception messages are recorded.

#### **AP\_NO**

Exception messages are not recorded.

#### **AP\_LEAVE\_UNCHANGED**

Leave exception logging unchanged from the existing definition. (The initial default, when the CS/AIX software is started, is that exception messages are recorded.)

### *succinct\_audits*

Specifies whether to use succinct logging or full logging in the audit log file. Possible values are:

#### **AP\_YES**

Succinct logging: each message in the log file contains a summary of the message header information (such as the message number, log type, and system name) and the message text

string and parameters. To obtain more details of the cause of the log and any action required, you can use the snahelp utility.

#### **AP\_NO**

Full logging: each message in the log file includes a full listing of the message header information, the message text string and parameters, and additional information about the cause of the log and any action required.

#### **AP\_LEAVE\_UNCHANGED**

Use the value (succinct logging or full logging) specified for this parameter on the previous SET\_GLOBAL\_LOG\_TYPE verb. The initial default, before any SET\_GLOBAL\_LOG\_TYPE verb has been issued, is to use succinct logging.

If you are using central logging, the choice of succinct or full logging for messages from all computers is determined by the setting of this parameter on the server acting as the central logger; this setting may either be from the SET\_GLOBAL\_LOG\_TYPE verb, or from a SET\_LOG\_TYPE verb issued to that server to override the default.

#### ***succinct\_errors***

Specifies whether to use succinct logging or full logging in the error log file; this applies to both exception logs and problem logs. The allowed values and their meanings are the same as for the *succinct\_audits* parameter.

## **Returned parameters: successful execution**

If the verb executes successfully, CS/AIX returns the following parameters:

#### ***primary\_rc***

AP\_OK

#### ***secondary\_rc***

Not used.

## **Returned parameters: parameter check**

If the verb does not execute because of a parameter error, CS/AIX returns the following parameters:

#### ***primary\_rc***

AP\_PARAMETER\_CHECK

#### ***secondary\_rc***

Possible values are:

#### **AP\_NOT\_CENTRAL\_LOGGER**

The verb was issued to a node that is not the central logger.

#### **AP\_INVALID\_SUCCINCT\_SETTING**

The *succinct\_audits* or *succinct\_errors* parameter was not set to a valid value.

## **Returned parameters: other conditions**

Appendix B, “Common return codes,” on page 661 lists further combinations of primary and secondary return codes that are common to all NOF verbs.

## **SET\_KERNEL\_MEMORY\_LIMIT**

This verb specifies a limit on the amount of kernel memory that CS/AIX can use at any one time. This allows you to ensure that memory is available for other processes on the AIX computer.

You can also specify the kernel memory limit when starting the CS/AIX software (for more information, see the *IBM Communications Server for Data Center Deployment on AIX Administration Guide*). This verb overrides the limit, if any, specified when starting the CS/AIX software.

## VCB structure

```
typedef struct set_kernel_memory_limit
{
    AP_UINT16      opcode;           /* verb operation code          */
    unsigned char  reserv2;         /* reserved                     */
    unsigned char  format;         /* reserved                     */
    AP_UINT16      primary_rc;      /* primary return code          */
    AP_UINT32      secondary_rc;    /* secondary return code        */
    AP_UINT32      limit;           /* kernel memory limit, 0 => no limit */
    unsigned char  reserv3[8];     /* Reserved                     */
} SET_KERNEL_MEMORY_LIMIT;
```

## Supplied parameters

The application supplies the following parameters:

### *opcode*

AP\_SET\_KERNEL\_MEMORY\_LIMIT

### *limit*

The maximum amount of kernel memory that CS/AIX should use at any time, in bytes. If a CS/AIX component attempts to allocate kernel memory that would take the total amount of memory currently allocated to CS/AIX components above this limit, the allocation attempt will fail.

To remove the limit set by a previous SET\_KERNEL\_MEMORY\_LIMIT verb, specify zero.

## Returned parameters: successful execution

If the verb executes successfully, CS/AIX returns the following parameters:

### *primary\_rc*

AP\_OK

### *secondary\_rc*

Not used.

## Returned parameters: other conditions

Appendix B, “Common return codes,” on [page 661](#) lists further combinations of primary and secondary return codes that are common to all NOF verbs.

## SET\_LOG\_FILE

This verb manages a file that CS/AIX uses to record log messages. It allows you to do the following:

- Specify a file used to record log messages (audit, error, or usage logs), and the backup file (to which log information is copied).
- Specify the maximum log file size (when the log file reaches this size, CS/AIX copies log information to the backup file and resets the log file).
- Copy the current contents of the log file to the backup file, and optionally delete the current file.

You can record audit log and error log messages in separate files, or record both types of messages in the same file.

If you are using central logging, as defined by SET\_CENTRAL\_LOGGING, this verb must be issued to the node that is acting as the central logger. Otherwise you can issue it to each node separately in order to specify a different log file on each node.

This verb can be issued from a NOF application running on an AIX or Linux client. The NOF application must run with the userid root, or with a userid that is a member of the sys group (AIX) or sna group (Linux).

## VCB structure

```
typedef struct set_log_file
{
    AP_UINT16      opcode;           /* verb operation code          */
    unsigned char  reserv2;         /* reserved                     */
    unsigned char  format;         /* reserved                     */
    AP_UINT16      primary_rc;     /* primary return code         */
    AP_UINT32      secondary_rc;   /* secondary return code       */
    unsigned char  log_file_type;  /* type of log file           */
    unsigned char  action;        /* reset and/or backup existing */
    unsigned char  file_name[81];  /* file name                   */
    unsigned char  backup_file_name[81]; /* backup file               */
    AP_UINT32      file_size;     /* log file size              */
    unsigned char  succinct;      /* reserved                    */
    unsigned char  reserv3[3];    /* reserved                    */
} SET_LOG_FILE;
```

## Supplied parameters

The application supplies the following parameters:

### ***opcode***

AP\_SET\_LOG\_FILE

### ***log\_file\_type***

The type of log file being managed. Possible values are:

#### **AP\_AUDIT\_FILE**

Audit log file (audit messages only).

#### **AP\_ERROR\_FILE**

Error log file (problem and exception messages).

#### **AP\_USAGE\_FILE**

Usage log file (information on current and peak usage of CS/AIX resources).

To record both audit and error messages in the same file, issue two SET\_LOG\_FILE verbs for the same file name, specifying AP\_AUDIT\_FILE on one verb and AP\_ERROR\_FILE on the other.

### ***action***

The action to be taken on the log file. Specify one of the following values:

#### **AP\_NO\_FILE\_ACTION**

Use the file specified in the *file\_name* parameter as the log file, and the file specified in the *backup\_file\_name* parameter as the backup file. After this verb completes successfully, all log messages of the type defined by *log\_file\_type* are written to the new log file. The log file that was used before this verb is issued, if any, is left unchanged.

#### **AP\_DELETE\_FILE**

Delete the contents of the current log file.

#### **AP\_BACKUP\_FILE**

Copy the contents of the current log file to the backup file, and then delete the contents of the current file.

### ***file\_name***

Name of the new log file.

To create the file in the default directory for diagnostics files, /var/sna, specify the file name with no path. To create the file in a different directory, specify either a full path or the path relative to the default directory. If you include the path, ensure that it is a valid path (either relative to the application's working directory or a full path) on any computer to which this verb is issued.

This parameter is an ASCII string of 1-80 characters, followed by a NULL character (binary zero). To continue logging to the file specified on a previous SET\_LOG\_FILE verb, specify a null string.

## SET\_LOG\_FILE

### ***backup\_file\_name***

Name of the backup log file. When the log file reaches the size specified by *file\_size* below, CS/AIX copies the current contents to the backup file and then clears the log file. You can also request a backup at any time using the action parameter above.

To create the file in the default directory for diagnostics files, `/var/sna`, specify the file name with no path. To create the file in a different directory, specify either a full path or the path relative to the default directory. If you include the path, ensure that it is a valid path (either relative to the application's working directory or a full path) on any computer to which this verb is issued.

This parameter is an ASCII string of 1-80 characters, followed by a NULL character (binary zero). To continue using the backup file specified on a previous SET\_LOG\_FILE verb, specify a null string.

### ***file\_size***

The maximum size of the log file specified by *log\_file\_type*. When a message written to the file causes the file size to exceed this limit, CS/AIX copies the current contents of the log file to the backup log file and clears the log file. This means that the maximum amount of disk space taken up by log files is approximately twice *file\_size*.

To continue using the file size specified on a previous SET\_LOG\_FILE verb, set this parameter to zero. The initial default value, before any SET\_LOG\_FILE verb has been issued, is 10,000,000 bytes. A value of zero indicates "continue using the existing file size" and not "no limit".

You may need to increase the size of the audit and error log files according to the size of the CS/AIX client/server network, to allow for the volume of log information generated in larger systems. In particular, consider increasing the log file size to allow for the following:

- Large numbers of clients or users (since a single communications link failure may result in large numbers of logs on the server relating to session failures)
- Activating audit logging as well as exception logging
- Using central logging instead of distributed logging
- Using full logging instead of succinct logging.

## Returned parameters: successful execution

If the verb executes successfully, CS/AIX returns the following parameters:

### ***primary\_rc***

AP\_OK

### ***secondary\_rc***

Not used.

## Returned parameters: parameter check

If the verb does not execute because of a parameter error, CS/AIX returns the following parameters:

### ***primary\_rc***

AP\_PARAMETER\_CHECK

### ***secondary\_rc***

Possible values are:

#### **AP\_INVALID\_FILE\_ACTION**

The *action* parameter was not set to a valid value.

#### **AP\_INVALID\_FILE\_TYPE**

The *log\_file\_type* parameter was not set to a valid value.

Appendix B, "Common return codes," on page 661 lists further secondary return codes associated with AP\_PARAMETER\_CHECK, which are common to all NOF verbs.

## Returned parameters: other conditions

Appendix B, “Common return codes,” on page 661 lists further combinations of primary and secondary return codes that are common to all NOF verbs.

## SET\_LOG\_TYPE

This verb specifies the types of information that CS/AIX records in log files on a particular server. It can be used to override the default settings specified on SET\_GLOBAL\_LOG\_TYPE, or to remove the override so that this server reverts to using the default settings. For more information about log files, see “SET\_LOG\_FILE” on page 568.

This verb can be issued from a NOF application running on an AIX or Linux client. The NOF application must run with the userid `root`, or with a userid that is a member of the `sys` group (AIX) or `sna` group (Linux).

### Problem

An abnormal event that degrades the system in a way perceptible to a user (such as abnormal termination of a session).

### Exception

An abnormal event that degrades the system but that is not immediately perceptible to a user (such as a resource shortage), or an event that does not degrade the system but may indicate the cause of later exceptions or problems (such as receiving an unexpected message from the remote system).

### Audit

A normal event (such as starting a session).

Problem and exception messages are logged to the error log file; audit messages are logged to the audit log file. Problem messages are always logged and cannot be disabled, but you can specify whether to log each of the other two message types. For each of the two files (audit and error), you can specify whether to use succinct logging (including only the text of the message and a summary of the message source) or full logging (including full details of the message source, cause, and any action required).

## VCB structure

```
typedef struct set_log_type
{
    AP_UINT16      opcode;           /* verb operation code          */
    unsigned char  reserv2;         /* reserved                     */
    unsigned char  format;         /* reserved                     */
    AP_UINT16      primary_rc;     /* primary return code          */
    AP_UINT32      secondary_rc;   /* secondary return code        */
    unsigned char  override;       /* override global defaults?    */
    unsigned char  audit;          /* audit logging on or off      */
    unsigned char  exception;      /* exception logging on or off  */
    unsigned char  succinct_audits; /* use succinct logging in audit file? */
    unsigned char  succinct_errors; /* use succinct logging in error file? */
    unsigned char  reserv3[3];     /* reserved                     */
} SET_LOG_TYPE;
```

## Supplied parameters

The application supplies the following parameters:

### *opcode*

AP\_SET\_LOG\_TYPE

### *override*

Specifies whether this verb is being used to override the global log types specified on SET\_GLOBAL\_LOG\_TYPE, or to revert to using these defaults. Possible values are:

## SET\_LOG\_TYPE

### **AP\_YES**

Override the global log types. The log types to be used on this server are specified by the *audit* and *exception* parameters below, and the choice of succinct or full logging is specified by the *succinct\_\** parameters below.

### **AP\_NO**

Revert to using the global log types. The *audit*, *exception*, and *succinct\_\** parameters below are ignored.

### **audit**

Specify whether audit messages are recorded on this server. Possible values are:

#### **AP\_YES**

Audit messages are recorded.

#### **AP\_NO**

Audit messages are not recorded.

#### **AP\_LEAVE\_UNCHANGED**

Leave audit logging unchanged from the existing definition.

### **exception**

Specify whether exception messages are recorded on this server. Possible values are:

#### **AP\_YES**

Exception messages are recorded.

#### **AP\_NO**

Exception messages are not recorded.

#### **AP\_LEAVE\_UNCHANGED**

Leave exception logging unchanged from the existing definition.

### **succinct\_audits**

Specifies whether to use succinct logging or full logging in the audit log file on this server. Possible values are:

#### **AP\_YES**

Succinct logging: each message in the log file contains a summary of the message header information (such as the message number, log type, and system name) and the message text string and parameters. To obtain more details of the cause of the log and any action required, you can use the *snahelp* utility.

#### **AP\_NO**

Full logging: each message in the log file includes a full listing of the message header information, the message text string and parameters, and additional information about the cause of the log and any action required.

#### **AP\_LEAVE\_UNCHANGED**

Leave succinct logging or full logging unchanged from the existing definition.

If you are using central logging, the choice of succinct or full logging for messages from all computers is determined by the setting of this parameter on the server acting as the central logger; this setting may either be from the *SET\_GLOBAL\_LOG\_TYPE* verb, or from a *SET\_LOG\_TYPE* verb issued to that server to override the default.

### **succinct\_errors**

Specifies whether to use succinct logging or full logging in the error log file on this server; this applies to both exception logs and problem logs. The allowed values and their meanings are the same as for the *succinct\_audits* parameter.

## Returned parameters: successful execution

If the verb executes successfully, CS/AIX returns the following parameters:

### **primary\_rc**

AP\_OK



**secondary\_rc**

Not used.

**Returned parameters: parameter check**

If the verb does not execute because of a parameter error, CS/AIX returns the following parameters:

**primary\_rc**

AP\_PARAMETER\_CHECK

**secondary\_rc****AP\_INVALID\_SUCCINCT\_SETTING**

The *succinct\_audits* or *succinct\_errors* parameter was not set to a valid value.

**Returned parameters: other conditions**

Appendix B, “Common return codes,” on page 661 lists further combinations of primary and secondary return codes that are common to all NOF verbs.

**SET\_PROCESSING\_MODE**

This verb specifies how the NOF application interacts with the target node, configuration file, or SNA network data file: whether the application has read-only access or read/write access, and whether the application has exclusive access to the domain configuration file so that other applications cannot access it.

This verb applies only to NOF applications running on a server. For an application running on a client, the only processing mode available is read-only mode (the default), in which the application can issue QUERY\_\* verbs but cannot define, start or stop resources. The client application cannot use SET\_PROCESSING\_MODE to select any other mode.

The target node or file is specified by the *target\_handle* parameter on the NOF API call; the application obtains this parameter from the verb CONNECT\_NODE (for a node) or OPEN\_FILE (for a file). For more information about the use of this parameter, see “NOF API entry points for AIX or Linux” on page 19.

This verb may be issued to the domain configuration file, to the sna.net file, or to a running node. The valid processing modes that can be set with this verb depend on the target type.

**VCB structure**

```
typedef struct set_processing_mode
{
    AP_UINT16      opcode;           /* verb operation code          */
    unsigned char  reserv2;         /* reserved                     */
    unsigned char  format;         /* reserved                     */
    AP_UINT16      primary_rc;     /* primary return code         */
    AP_UINT32      secondary_rc;   /* secondary return code       */
    unsigned char  mode;          /* new mode to be set for this handle */
    AP_UINT16      reserv1;       /* reserved                     */
} SET_PROCESSING_MODE;
```

**Supplied parameters****opcode**

AP\_SET\_PROCESSING\_MODE

**mode**

Requested mode for this target handle. The mode cannot be changed while any previous verbs issued using this target handle are still outstanding. Possible values are:

**AP\_MODE\_READ\_ONLY**

Read-only mode: the application will use only QUERY\_\* verbs, which do not modify the configuration. This option can be used with either a file or a node as the target.

## SET\_PROCESSING\_MODE

### AP\_MODE\_READ\_WRITE

Read / write mode: the application may use any NOF API verbs. This option can be used with either a file or a node as the target.

### AP\_MODE\_COMMIT

Commit mode: the application has exclusive read/write access to the target file, so that other applications cannot access it until this application releases it. This option can be used only with the domain configuration file as the target.

This mode is intended for issuing a series of connected verbs to a file (such as a series of DEFINE verbs for related components). The application should complete the series of verbs as quickly as possible and then reset its processing mode to one of the other options, in order to release the file so that other NOF API applications or CS/AIX components can access it.

**Note:** To obtain read/write or commit access to the file, your NOF application must be running with a user ID that is a member of the SNA administrators group `system` or `sna` (or running as `root`). If the user ID is not a member of this group or `root`, the only valid processing mode is `AP_MODE_READ_ONLY`.

## Returned parameters: successful execution

If the verb executes successfully, CS/AIX returns the following parameters:

### *primary\_rc*

AP\_OK

### *secondary\_rc*

Not used.

## Returned parameters: parameter check

If the verb does not execute because of a parameter error, CS/AIX returns the following parameters:

### *primary\_rc*

AP\_PARAMETER\_CHECK

### *secondary\_rc*

Possible values are:

#### **AP\_INVALID\_PROC\_MODE**

The *mode* parameter was not set to a valid value.

#### **AP\_INVALID\_TARGET\_MODE**

The *mode* parameter was not valid for the selected target.

Appendix B, "Common return codes," on page 661 lists further secondary return codes associated with `AP_PARAMETER_CHECK`, which are common to all NOF verbs.

## Returned parameters: state check

If the verb does not execute because of a state check, CS/AIX returns the following parameters.

### *primary\_rc*

AP\_STATE\_CHECK

### *secondary\_rc*

Possible values are:

#### **AP\_FILE\_UNAVAILABLE**

The application specified commit mode, but was unable to get exclusive access to the required configuration file. This may be because another application is accessing the file in commit mode.

#### **AP\_VERB\_IN\_PROGRESS**

The processing mode for the specified target handle cannot be changed because a previous verb issued for this handle is still outstanding. All verbs for the target handle must be completed before attempting to change the processing mode.

**AP\_NOT\_AUTHORIZED**

The NOF application cannot obtain read/write access to the file because it is running on a client, or because it is running with a user ID that is not a member of the SNA administrators group system. If the user ID is not a member of this group, the only valid processing mode is AP\_MODE\_READ\_ONLY.

**AP\_NOT\_CONTROLLER**

The processing mode cannot be changed to AP\_MODE\_READ\_WRITE or AP\_MODE\_COMMIT because the target handle specifies a file (either the domain configuration file or the SNA network data file) on a backup server that is no longer acting as the controller server. Changes to the running configuration file can be made only to the copy of this file on the controller (so that they will be distributed to other servers); other copies of the file can be accessed only in read-only mode. If the application needs to use read/write or commit mode, it should issue CLOSE\_FILE for this target handle, and then reissue OPEN\_FILE to access the file on the new controller server.

Appendix B, “Common return codes,” on page 661 lists further secondary return codes associated with AP\_STATE\_CHECK, which are common to all NOF verbs.

**Returned parameters: other conditions**

Appendix B, “Common return codes,” on page 661 lists further combinations of primary and secondary return codes that are common to all NOF verbs.

**SET\_TN3270\_SLP\_TRACE**

This verb specifies tracing options for the CS/AIX TN3270 Service Location Protocol component.

This verb must be issued to a running node.

**VCB structure**

```
typedef struct set_tn3270_slp_trace
{
    AP_UINT16      opcode;           /* verb operation code      */
    unsigned char  reserv2;         /* reserved                  */
    unsigned char  format;         /* reserved                  */
    AP_UINT16      primary_rc;     /* primary return code      */
    AP_UINT32      secondary_rc;   /* secondary return code    */
    AP_UINT16      trace_flags;    /* trace flags              */
    unsigned char  reserv3[6];     /* reserved                  */
} SET_TN3270_SLP_TRACE;
```

**Supplied parameters**

The application supplies the following parameters:

***opcode***

AP\_SET\_TN3270\_SLP\_TRACE

***trace\_flags***

The types of tracing required. To turn off all tracing, or to turn on tracing of all types, specify one of the following values:

**AP\_TN3270\_SLP\_NO\_TRACE**

No tracing.

**AP\_TN3270\_SLP\_ALL\_TRACE**

Tracing of all types.

To activate tracing on specific message types, select one or more values from the list below, combined using a logical OR operation.

**AP\_TN3270\_SLP\_TRC\_CFG**

Configuration message tracing: messages relating to the configuration of TN3270 SLP

## SET\_TN\_SERVER\_TRACE

### AP\_TN3270\_SLP\_TRC\_NOF

Internal node operator function (NOF) tracing: trace NOF requests made by TN3270 SLP

### AP\_TN3270\_SLP\_TRC\_TCP

TCP/IP interface tracing: messages between TN3270 SLP and TN3270 clients

## Returned parameters: successful execution

If the verb executes successfully, CS/AIX returns the following parameters:

### *primary\_rc*

AP\_OK

### *secondary\_rc*

Not used.

## Returned parameters: other conditions

Appendix B, “Common return codes,” on page 661 lists further combinations of primary and secondary return codes that are common to all NOF verbs.

## SET\_TN\_SERVER\_TRACE

---

This verb specifies tracing options for the CS/AIX TN server component.

This verb must be issued to a running node.

## VCB structure

```
typedef struct set_tn_server_trace
{
    AP_UINT16      opcode;           /* verb operation code      */
    unsigned char  reserv2;         /* reserved                  */
    unsigned char  format;         /* reserved                  */
    AP_UINT16      primary_rc;     /* primary return code      */
    AP_UINT32      secondary_rc;   /* secondary return code    */
    AP_UINT16      trace_flags;    /* trace flags               */
    unsigned char  reserv3[6];     /* reserved                  */
} SET_TN_SERVER_TRACE;
```

## Supplied parameters

The application supplies the following parameters:

### *opcode*

AP\_SET\_TN\_SERVER\_TRACE

### *trace\_flags*

The types of tracing required. To turn off all tracing, or to turn on tracing of all types, specify one of the following values:

### AP\_TN\_SERVER\_NO\_TRACE

No tracing.

### AP\_TN\_SERVER\_ALL\_TRACE

Tracing of all types.

To activate tracing on specific message types, select one or more values from the list below, combined using a logical OR operation.

### AP\_TN\_SERVER\_TRC\_TCP

TCP/IP interface tracing: messages between TN server and TN3270 clients

### AP\_TN\_SERVER\_TRC\_FM

Node interface tracing: internal control messages, and messages between TN server and TN3270 clients (in internal format)

**AP\_TN\_SERVER\_TRC\_CFG**

Configuration message tracing: messages relating to the configuration of TN server

**AP\_TN\_SERVER\_TRC\_NOF**

Internal node operator function (NOF) tracing: trace NOF requests made by TN server.

**Returned parameters: successful execution**

If the verb executes successfully, CS/AIX returns the following parameters:

***primary\_rc***

AP\_OK

***secondary\_rc***

Not used.

**Returned parameters: other conditions**

Appendix B, “Common return codes,” on page 661 lists further combinations of primary and secondary return codes that are common to all NOF verbs.

**SET\_TRACE\_FILE**

This verb specifies the name of a file that CS/AIX uses to record trace data.

If you issue a second SET\_TRACE\_FILE verb specifying a new file for the same file type, all subsequent trace information will be written to the new file; the existing file is not removed, but further information will not be written to it. If you issue a second SET\_TRACE\_FILE verb for the same trace file, this resets the file (discarding trace information that was written to the file before the second verb).

This verb must be issued to a running node.

**VCB structure**

```
typedef struct set_trace_file
{
    AP_UINT16      opcode;                /* verb operation code */
    unsigned char  reserv2;              /* reserved */
    unsigned char  format;              /* reserved */
    AP_UINT16      primary_rc;          /* primary return code */
    AP_UINT32      secondary_rc;        /* secondary return code */
    unsigned char  trace_file_type;     /* type of trace file */
    unsigned char  dual_files;          /* dual trace files */
    AP_UINT32      trace_file_size;     /* trace file size */
    unsigned char  reserv3[4];          /* reserved */
    unsigned char  file_name[81];       /* file name */
    unsigned char  file_name_2[81];     /* second file name */
} SET_TRACE_FILE;
```

**Supplied parameters**

The application supplies the following parameters:

***opcode***

AP\_SET\_TRACE\_FILE

***trace\_file\_type***

The type of trace file. Possible values are:

**AP\_CS\_TRACE**

File contains tracing on data transferred across the CS/AIX LAN between the specified computer and other nodes (activated by the SET\_CS\_TRACE verb).

**AP\_TN\_SERVER\_TRACE**

File contains tracing on the CS/AIX TN server component.

## SET\_TRACE\_FILE

### AP\_TN3270\_SLP\_TRACE

File contains tracing on the CS/AIX TN3270 Service Location Protocol component.

### AP\_IPS\_TRACE

File contains tracing on kernel components for the specified node (activated by the SET\_TRACE\_TYPE or ADD\_DLC\_TRACE verb).

### *dual\_files*

Specifies whether tracing is to one file or to two files. Possible values are:

#### AP\_YES

Tracing is to two files. When the first file reaches the size specified by *trace\_file\_size*, the second file is cleared, and tracing continues to the second file. When this file then reaches the size specified by *trace\_file\_size*, the first file is cleared, and tracing continues to the first file. This ensures that tracing can continue for long periods without using excessive disk space; the maximum space required is approximately twice the value of *trace\_file\_size*.

#### AP\_NO

Tracing is to one file.

#### AP\_LEAVE\_UNCHANGED

Leave the *dual\_files* setting unchanged from the existing definition. (The initial default, when the CS/AIX software is started, is to use two files.)

### *trace\_file\_size*

The maximum size of the trace file, in bytes. The initial default value, before any SET\_TRACE\_FILE verb has been issued, is 10,000,000 bytes. To continue using the existing file size definition, specify zero.

If *dual\_files* is set to AP\_YES, tracing will switch between the two files when the current file reaches this size. If *dual\_files* is set to AP\_NO, this parameter is ignored; the file size is not limited.

You may need to increase the size of the trace files according to the size of the CS/AIX client/server network, to allow for the volume of trace information generated in larger systems. In particular, consider increasing the trace file size on a server to allow for large numbers of clients or users accessing the server.

### *file\_name*

Name of the trace file, or of the first trace file if *dual\_files* is set to AP\_YES. To continue using the file name specified on a previous SET\_TRACE\_FILE verb, set this parameter to a null string.

To create the file in the default directory for diagnostics files, */var/sna*, specify the file name with no path. To create the file in a different directory, specify either a full path or the path relative to the default directory. If you include the path, ensure that it is a valid path (either relative to the application's working directory or a full path) on any computer to which this verb is issued.

This parameter is an ASCII string of 1-80 characters, followed by a NULL character (binary zero).

### *file\_name\_2*

Name of the second trace file; this parameter is used only if *dual\_files* is set to AP\_YES. To continue using the file name specified on a previous *set\_trace\_file* verb, set this parameter to a null string.

To create the file in the default directory for diagnostics files, */var/sna*, specify the file name with no path. To create the file in a different directory, specify either a full path or the path relative to the default directory. If you include the path, ensure that it is a valid path (either relative to the application's working directory or a full path) on any computer to which this verb is issued.

This parameter is an ASCII string of 1-80 characters, followed by a NULL character (binary zero).

## Returned parameters: successful execution

If the verb executes successfully, CS/AIX returns the following parameters:

### *primary\_rc*

AP\_OK

**secondary\_rc**

Not used.

**Returned parameters: parameter check**

If the verb does not execute because of a parameter error, CS/AIX returns the following parameters:

**primary\_rc**

AP\_PARAMETER\_CHECK

**secondary\_rc**

Possible values are:

**AP\_INVALID\_FILE\_NAME**

The *file\_name* or *file\_name\_2* parameter was not set to a valid AIX file name, or *file\_name\_2* was not specified when changing from a single trace file to dual trace files.

**AP\_INVALID\_FILE\_TYPE**

The *trace\_file\_type* parameter was not set to a valid value.

Appendix B, “Common return codes,” on page 661 lists further secondary return codes associated with AP\_PARAMETER\_CHECK, which are common to all NOF verbs.

**Returned parameters: other conditions**

Appendix B, “Common return codes,” on page 661 lists further combinations of primary and secondary return codes that are common to all NOF verbs.

**SET\_TRACE\_TYPE**

This verb specifies tracing options for CS/AIX kernel components. You can use this verb to specify the state of tracing (on or off) at all interfaces, or to turn tracing on or off at specific interfaces (leaving tracing at other interfaces unchanged). For more information about tracing options, see the *IBM Communications Server for Data Center Deployment on AIX Administration Guide*.

To control DLC line tracing, use the ADD\_DLC\_TRACE verb. The truncation length specified on this verb also applies to DLC tracing, but the tracing options on this verb do not apply to DLC tracing.

This verb must be issued to a running node.

**VCB structure**

```
typedef struct set_trace_type
{
    AP_UINT16      opcode;                /* verb operation code          */
    unsigned char  reserv2;              /* reserved                     */
    unsigned char  format;              /* reserved                     */
    AP_UINT16      primary_rc;          /* primary return code         */
    AP_UINT32      secondary_rc;       /* secondary return code       */
    AP_UINT16      trace_flags;        /* trace flags                 */
    AP_UINT32      truncation_length;  /* truncate each msg to this size */
    unsigned char  init_flags;         /* TRUE if initializing flags   */
    unsigned char  set_flags;          /* TRUE if setting flags       */
                                     /* FALSE if unsetting flags    */
    unsigned char  set_internal;        /* reserved                    */
    AP_UINT16      internal_level;     /* reserved                    */
    AP_UINT32      api_flags;          /* api trace flags             */
} SET_TRACE_TYPE;
```

**Supplied parameters**

The application supplies the following parameters:

**opcode**

AP\_SET\_TRACE\_TYPE

## SET\_TRACE\_TYPE

### *trace\_flags*

The types of tracing required. To turn off all tracing, or to turn on tracing of all types, specify one of the following values:

#### **AP\_NO\_TRACE**

No tracing.

#### **AP\_ALL\_TRACE**

Tracing of all types.

To control tracing on specific interfaces, select one or more values from the list below, combined using a logical OR operation. For more information about these trace types, see [“Trace types” on page 581](#).

If *init\_flags* is set to AP\_YES, select the values corresponding to the interfaces where you want tracing to be active, and do not select the values corresponding to the interfaces where you want it to be inactive. If *init\_flags* is set to AP\_NO, select the values corresponding to the interfaces where you want to change the state of tracing.

#### **AP\_APPC\_MSG**

APPC messages

#### **AP\_LUA\_MSG**

LUA messages

#### **AP\_NOF\_MSG**

NOF messages

#### **AP\_MS\_MSG**

MS messages

#### **AP\_GDLC\_MSG**

GDLC messages

#### **AP\_IPDL\_MSG**

Enterprise Extender (HPR/IP) messages

#### **AP\_DLC\_MSG**

Node to DLC messages

#### **AP\_NODE\_MSG**

Node messages

#### **AP\_SLIM\_MSG**

Messages sent between controller and backup servers

#### **AP\_DATAGRAM**

Datagram messages

### *truncation\_length*

Specify the maximum length, in bytes, of the information to be written to the trace file for each message. This value must be at least 256.

If a trace message is longer than the length specified in this parameter, CS/AIX writes only the start of the message to the trace file, and discards the data beyond *truncation\_length*. This allows you to record the most important information for each message but avoid filling up the file with long messages.

To specify no truncation (all the data from each message is written to the file), set this parameter to zero.

### *init\_flags*

Specifies whether to initialize tracing (define the tracing state at all interfaces), or to change the state of tracing at one or more interfaces (leaving the others unchanged). Possible values are:

#### **AP\_YES**

Tracing is being initialized. The *trace\_flags* parameter defines the required state of tracing at all interfaces.



**AP\_NO**

Tracing is being changed. The *trace\_flags* parameter defines the interfaces where tracing is being activated or deactivated; other interfaces will not be affected.

**set\_flags**

If *init\_flags* is set to AP\_NO, this parameter specifies whether tracing is to be activated or deactivated at the requested interfaces. Possible values are:

**AP\_YES**

Tracing is to be activated at the interfaces specified by the *trace\_flags* parameter.

**AP\_NO**

Tracing is to be deactivated at the interfaces specified by the *trace\_flags* parameter.

If *init\_flags* is set to AP\_YES, this parameter is ignored.

**Returned parameters: successful execution**

If the verb executes successfully, CS/AIX returns the following parameters:

**primary\_rc**

AP\_OK

**secondary\_rc**

Not used.

**Returned parameters: parameter check**

If the verb does not execute because of a parameter error, CS/AIX returns the following parameters:

**primary\_rc**

AP\_PARAMETER\_CHECK

**secondary\_rc****AP\_INVALID\_TRUNC\_LEN**

The *truncation\_length* parameter specified a length of less than 256 bytes.

Appendix B, “Common return codes,” on page 661 lists further secondary return codes associated with AP\_PARAMETER\_CHECK, which are common to all NOF verbs.

**Returned parameters: other conditions**

Appendix B, “Common return codes,” on page 661 lists further combinations of primary and secondary return codes that are common to all NOF verbs.

**Trace types**

Figure 2 on page 582, shows the overall structure of CS/AIX. Each kernel-space trace type, relating to data transferred across a particular interface between CS/AIX components, is shown in the diagram at the interface where it is traced.

## SET\_TRACE\_TYPE

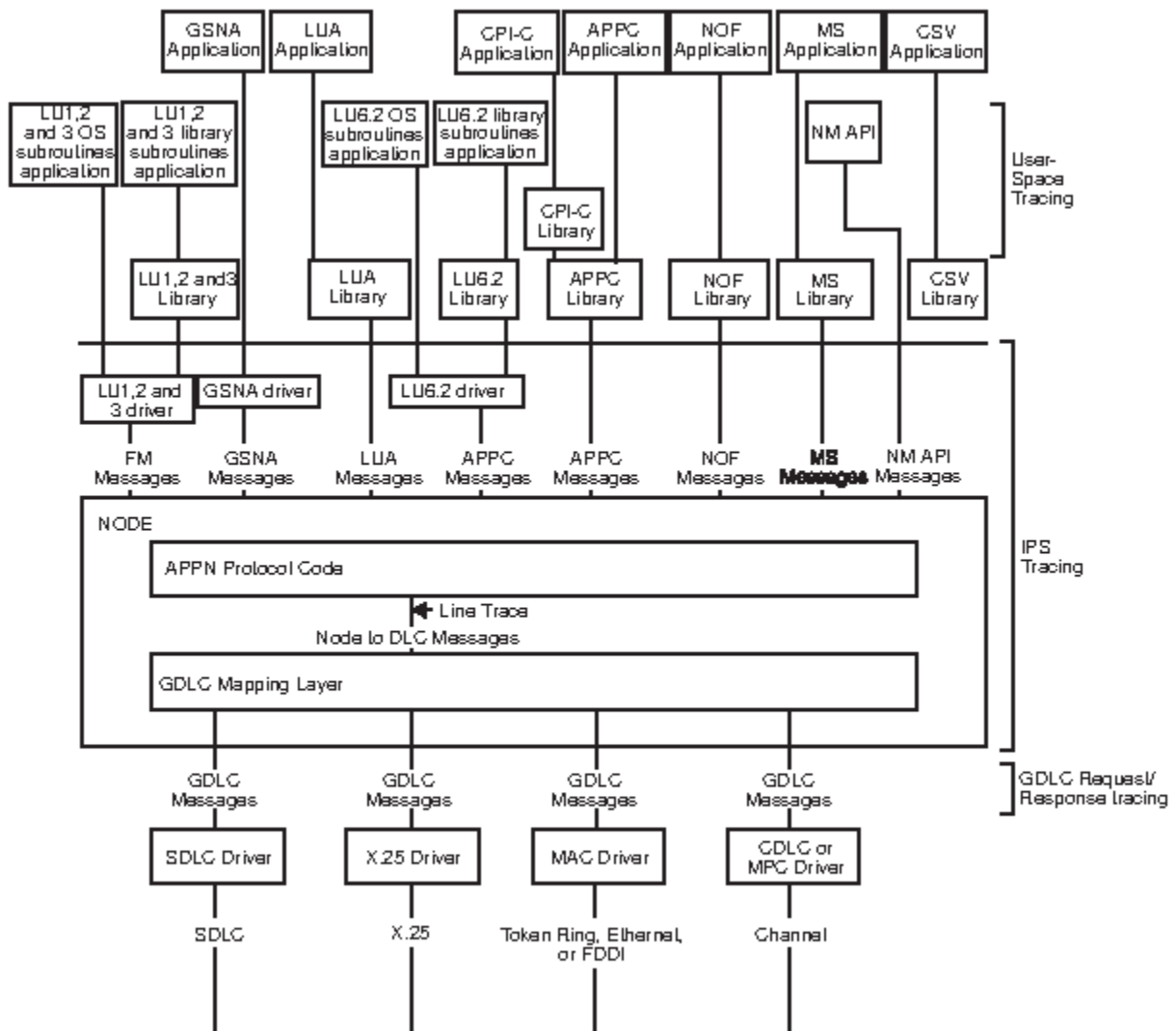

Figure 2. Overall Structure of CS/AIX

Figure 2 on page 582 shows the following types of tracing, each of which can be controlled separately:

### APPC messages

Messages between the APPC library and the node

### LUA messages

Messages between the LUA library and the node

### NOF messages

Messages between the NOF library and the node

### MS messages

Messages between the MS library and the node

### DLC line trace

SNA data sent on a DLC (tracing on these messages is controlled by the ADD\_DLC\_TRACE verb, not by SET\_TRACE\_TYPE)

### Node to DLC messages

Messages between the APPN node and the DLC component

In addition, the following message types (internal to CS/AIX) can be traced:

### Node messages

Messages between components within the APPN protocol code

**Control messages**

Internal control messages between system components

**START\_DLC**

START\_DLC requests the activation of a DLC.

This verb must be issued to a running node.

**VCB structure**

```
typedef struct start_dlc
{
    AP_UINT16      opcode;                /* verb operation code    */
    unsigned char  reserv2;              /* reserved                */
    unsigned char  format;               /* reserved                */
    AP_UINT16      primary_rc;           /* primary return code     */
    AP_UINT32      secondary_rc;         /* secondary return code   */
    unsigned char  dlc_name[8];          /* name of DLC             */
} START_DLC;
```

**Supplied parameters**

The application supplies the following parameters:

***opcode***

AP\_START\_DLC

***dlc\_name***

Name of the DLC to be started. This is an 8-byte ASCII string, padded on the right with spaces if the name is shorter than 8 bytes, which must match the name of a defined DLC.

**Returned parameters: successful execution**

If the verb executes successfully, CS/AIX returns the following parameter:

***primary\_rc***

AP\_OK

This return code indicates only that the verb was issued successfully; the verb does not wait for the DLC to initialize, and so does not return error return codes if the initialization of the DLC fails. DLC initialization failures are reported using messages written to the error log file.

**Returned parameters: parameter check**

If the verb does not execute because of a parameter error, CS/AIX returns the following parameters:

***primary\_rc***

AP\_PARAMETER\_CHECK

***secondary\_rc***

**AP\_INVALID\_DLC**

The *dlc\_name* parameter was not the name of a defined DLC.

Appendix B, “Common return codes,” on page 661 lists further secondary return codes associated with AP\_PARAMETER\_CHECK, which are common to all NOF verbs.

**Returned parameters: state check**

If the verb does not execute because of a state error, CS/AIX returns the following parameters.

***primary\_rc***

AP\_STATE\_CHECK

## START\_INTERNAL\_PU

### *secondary\_rc*

#### **AP\_DLC\_DEACTIVATING**

The specified DLC has already been started, and is in the process of being deactivated.

Appendix B, “Common return codes,” on page 661 lists further secondary return codes associated with AP\_STATE\_CHECK, which are common to all NOF verbs.

## Returned parameters: other conditions

Appendix B, “Common return codes,” on page 661 lists further combinations of primary and secondary return codes that are common to all NOF verbs.

## START\_INTERNAL\_PU

START\_INTERNAL\_PU requests DLUR to initiate SSCP-PU session activation for a previously defined local PU which is served by DLUR.

This verb must be issued to a running node.

## VCB structure

```
typedef struct start_internal_pu
{
    AP_UINT16      opcode;           /* verb operation code      */
    unsigned char  reserv2;         /* reserved                  */
    unsigned char  format;          /* reserved                  */
    AP_UINT16      primary_rc;      /* primary return code      */
    AP_UINT32      secondary_rc;    /* secondary return code    */
    unsigned char  pu_name[8];      /* internal PU name         */
    unsigned char  dlus_name[17];   /* DLUS name                */
    unsigned char  bkup_dlus_name[17]; /* Backup DLUS name        */
} START_INTERNAL_PU;
```

## Supplied parameters

The application supplies the following parameters:

### ***opcode***

AP\_START\_INTERNAL\_PU

### ***pu\_name***

Name of the internal PU to be started (which must have been previously defined using DEFINE\_INTERNAL\_PU). The name is an 8-byte type-A EBCDIC string (starting with a letter), padded on the right with EBCDIC spaces.

### ***dlus\_name***

Name of DLUS node which DLUR will contact to solicit SSCP-PU session activation for the given PU. The name is a 17-byte EBCDIC string, right-padded with EBCDIC spaces. It consists of a network ID of up to 8 A-string characters, an EBCDIC dot (period) character, and a network name of up to 8 A-string characters.

To use the DLUS specified in the DEFINE\_INTERNAL\_PU verb, or the global default specified in DEFINE\_DLUR\_DEFAULTS if none was specified in DEFINE\_INTERNAL\_PU, set this parameter to 17 binary zeros.

### ***bkup\_dlus\_name***

Name of DLUS node which DLUR will store as the backup DLUS for the given PU. The name is a 17-byte EBCDIC string, right-padded with EBCDIC spaces. It consists of a network ID of up to 8 A-string characters, an EBCDIC dot (period) character, and a network name of up to 8 A-string characters.

To use the backup DLUS specified in the DEFINE\_INTERNAL\_PU verb, or the global backup default specified in DEFINE\_DLUR\_DEFAULTS if none was specified in DEFINE\_INTERNAL\_PU, set this parameter to 17 binary zeros.

## Returned parameters: successful execution

If the verb executes successfully, CS/AIX returns the following parameters:

**primary\_rc**  
AP\_OK

## Returned parameters: parameter check

If the verb does not execute because of a parameter error, CS/AIX returns the following parameters:

**primary\_rc**  
AP\_PARAMETER\_CHECK

**secondary\_rc**  
Possible values are:

**AP\_INVALID\_DLUS\_NAME**  
The *dlus\_name* parameter contained a character that was not valid or was not in the correct format.

**AP\_INVALID\_BKUP\_DLUS\_NAME**  
The *bkup\_dlus\_name* parameter contained a character that was not valid or was not in the correct format.

## Returned parameters: state check

If the verb does not execute because of a state error, CS/AIX returns the following parameters.

**primary\_rc**  
AP\_STATE\_CHECK

**secondary\_rc**  
Possible values are:

**AP\_NO\_DEFAULT\_DLUS\_DEFINED**  
A DLUS name was not specified either on this verb or on the DEFINE\_INTERNAL\_PU verb, and there is no default DLUS defined because the DEFINE\_DLUR\_DEFAULTS verb has not been issued.

**AP\_PU\_NOT\_DEFINED**  
The supplied PU name was not the name of an internal PU defined using DEFINE\_INTERNAL\_PU.

**AP\_PU\_ALREADY\_ACTIVATING**  
The PU is already in the process of being started.

**AP\_PU\_ALREADY\_ACTIVE**  
The PU has already been started.

## Returned parameters: unsuccessful

If the verb does not execute successfully, CS/AIX returns the following parameters.

**primary\_rc**  
AP\_UNSUCCESSFUL

**secondary\_rc**  
Possible values are:

**AP\_DLUS\_REJECTED**  
The DLUS rejected the session activation request.

**AP\_DLUS\_CAPS\_MISMATCH**  
The configured DLUS name was not a DLUS node.

**AP\_PU\_FAILED\_ACTPU**  
The local node rejected a message from the DLUS. This may be caused by an internal error, a resource shortage, or a problem with the received message; check the CS/AIX log files for messages providing more information.

## START\_LS

### Returned parameters: function not supported

If the verb does not execute because the node's configuration does not support it, CS/AIX returns the following parameter:

#### *primary\_rc*

##### **AP\_FUNCTION\_NOT\_SUPPORTED**

The node does not support DLUR; this is defined by the *dlur\_supported* parameter on DEFINE\_NODE.

### Returned parameters: other conditions

Appendix B, “Common return codes,” on page 661 lists further combinations of primary and secondary return codes that are common to all NOF verbs.

## START\_LS

START\_LS normally starts an inactive LS. Alternatively, it can be used to leave the LS inactive but specify that it can be activated automatically by CS/AIX when required or activated by the remote system.

**Note:** If the LS is a leased SDLC link or a QLLC PVC link, it must be activated by the remote system as well as by CS/AIX. You are recommended to define the LS to be activated when the node is started and to be reactivated automatically after failures, to ensure that the link is always available; see “[DEFINE\\_LS](#)” on page 100 for more information.

This verb must be issued to a running node.

### VCB structure

```
typedef struct start_ls
{
    AP_UINT16      opcode;           /* verb operation code          */
    unsigned char  reserv2;         /* reserved                     */
    unsigned char  format;         /* reserved                     */
    AP_UINT16      primary_rc;     /* primary return code         */
    AP_UINT32      secondary_rc;   /* secondary return code       */
    unsigned char  ls_name[8];     /* name of link station        */
    unsigned char  enable;         /* start ls or enable auto-activation? */
    unsigned char  react_kicked;   /* retry in progress?         */
    unsigned char  reserv3[2];     /* reserved                    */
} START_LS;
```

### Supplied parameters

The application supplies the following parameters:

#### **opcode**

AP\_START\_LS

#### **ls\_name**

Name of the link station to be started. This is an 8-byte ASCII string, padded on the right with spaces if the name is shorter than 8 bytes, which must already have been defined by a DEFINE\_LS verb.

#### **enable**

Specifies the action to be taken for the LS.

To start the LS, set this parameter to AP\_ACTIVATE.

To leave the LS inactive but specify that it can be activated (either by CS/AIX or by the remote system) when required, specify one or both of the following values (combined using a logical OR):

#### **AP\_AUTO\_ACT**

The LS can be activated automatically by CS/AIX when required for a session. This value should be used only when the LS is defined to be auto-activatable (*auto\_act\_supp* in the LS definition is set to AP\_YES); it re-enables auto-activation after the LS has been manually stopped using STOP\_LS.

**AP\_REMOTE\_ACT**

The LS can be activated by the remote system. This value does not alter the defined value of *disable\_remote\_act* in the LS definition; when the LS is next stopped, it will return to the defined setting.

**Returned parameters: successful execution**

If the verb executes successfully, CS/AIX returns the following parameters:

**primary\_rc**  
AP\_OK

**Returned parameters: parameter check**

If the verb does not execute because of a parameter error, CS/AIX returns the following parameters:

**primary\_rc**  
AP\_PARAMETER\_CHECK

**secondary\_rc**  
Possible values are:

**AP\_INVALID\_LINK\_NAME\_SPECIFIED**

The *ls\_name* parameter was not the name of a defined LS.

**AP\_INVALID\_LINK\_ENABLE**

The *enable* parameter was not set to a valid value.

Appendix B, “Common return codes,” on page 661 lists further secondary return codes associated with AP\_PARAMETER\_CHECK, which are common to all NOF verbs.

**Returned parameters: state check**

If the verb does not execute because of a state error, CS/AIX returns the following parameters.

**primary\_rc**  
AP\_STATE\_CHECK

**secondary\_rc**  
Possible values are:

**AP\_ACTIVATION\_LIMITS\_REACHED**

The activation limits have been reached.

**AP\_LINK\_DEACT\_IN\_PROGRESS**

The specified LS is currently being deactivated. You cannot start it until the deactivation process has finished.

**AP\_ALREADY\_STARTING**

The specified LS is already starting.

**AP\_PARALLEL\_TGS\_NOT\_SUPPORTED**

A link to the remote system is already active. The adjacent node does not support parallel transmission groups.

**AP\_PORT\_INACTIVE**

The LS cannot be started because its associated port is not active.

**react\_kicked**

Specifies whether CS/AIX will retry the attempt to activate the LS (based on the *react\_timer\_retry* parameter in the LS definition). Possible values are:

**AP\_YES**

LS activation will be retried (up to the number of attempts specified by *react\_timer\_retry*).

**AP\_NO**

LS activation will not be retried.

## START\_PORT

Appendix B, “Common return codes,” on page 661 lists further secondary return codes associated with AP\_STATE\_CHECK, which are common to all NOF verbs.

### Returned parameters: unsuccessful

If the verb does not execute successfully because the SNA subsystem on the remote computer cannot be contacted, CS/AIX returns the following parameters:

**primary\_rc**

AP\_LS\_FAILURE

**secondary\_rc**

Possible values are:

**AP\_PARTNER\_NOT\_FOUND**

No response was received from the port associated with this LS. For Token Ring, Ethernet: check that the *mac\_address* parameter in the LS definition is correct.

**AP\_ERROR**

The connection to the remote computer could not be established. This may be because the SNA subsystem on the remote computer is not started. For link types other than LAN types (Token Ring, Ethernet), it may also indicate that CS/AIX could not find a remote computer matching the supplied addressing information.

### Returned parameters: cancelled

If the verb does not execute because it was cancelled by another verb, CS/AIX returns the following parameters:

**primary\_rc**

AP\_CANCELLED

**secondary\_rc**

Possible values are:

**AP\_NO\_SECONDARY\_RC**

A STOP\_LS verb was issued before the START\_LS verb had completed. The START\_LS verb was cancelled.

**AP\_LINK\_DEACTIVATED**

The DLC or port used by the LS was stopped before the START\_LS verb had completed. The START\_LS verb was cancelled.

**react\_kicked**

Specifies whether CS/AIX will retry the attempt to activate the LS (based on the *react\_timer\_retry* parameter in the LS definition). Possible values are:

**AP\_YES**

LS activation will be retried (up to the number of attempts specified by *react\_timer\_retry*).

**AP\_NO**

LS activation will not be retried.

### Returned parameters: other conditions

Appendix B, “Common return codes,” on page 661 lists further combinations of primary and secondary return codes that are common to all NOF verbs.

## START\_PORT

---

START\_PORT requests the activation of a port. The DLC specified for the port must be active before this verb is issued.

This verb must be issued to a running node.



## VCB structure

```
typedef struct start_port
{
    AP_UINT16      opcode;           /* verb operation code      */
    unsigned char  reserv2;         /* reserved                  */
    unsigned char  format;          /* reserved                  */
    AP_UINT16      primary_rc;      /* primary return code      */
    AP_UINT32      secondary_rc;    /* secondary return code    */
    unsigned char  port_name[8];    /* name of port             */
} START_PORT;
```

## Supplied parameters

The application supplies the following parameters:

### *opcode*

AP\_START\_PORT

### *port\_name*

Name of port to be started. This is an 8-byte ASCII string, padded on the right with spaces if the name is shorter than 8 bytes, which must already have been defined by a DEFINE\_PORT verb.

## Returned parameters: successful execution

If the verb executes successfully, CS/AIX returns the following parameters:

### *primary\_rc*

AP\_OK

## Returned parameters: parameter check

If the verb does not execute because of a parameter error, CS/AIX returns the following parameters:

### *primary\_rc*

AP\_PARAMETER\_CHECK

### *secondary\_rc*

#### **AP\_INVALID\_PORT**

The *port\_name* parameter was not the name of a defined port.

Appendix B, “Common return codes,” on page 661 lists further secondary return codes associated with AP\_PARAMETER\_CHECK, which are common to all NOF verbs.

## Returned parameters: state check

If the verb does not execute because of a state error, CS/AIX returns the following parameters.

### *primary\_rc*

AP\_STATE\_CHECK

### *secondary\_rc*

Possible values are:

#### **AP\_DLC\_INACTIVE**

The port cannot be started because its associated DLC is not active.

#### **AP\_DUPLICATE\_PORT**

The specified port has already been started.

#### **AP\_STOP\_PORT\_PENDING**

The specified port is currently being deactivated. You cannot start it until the deactivation process has finished.

Appendix B, “Common return codes,” on page 661 lists further secondary return codes associated with AP\_STATE\_CHECK, which are common to all NOF verbs.

## STOP\_DLC

### Returned parameters: cancelled

If the verb does not execute because it was cancelled, CS/AIX returns the following parameters.

#### *primary\_rc*

##### **AP\_CANCELLED**

A STOP\_PORT verb was issued before this verb had completed. The START\_PORT verb was cancelled.

### Returned parameters: other conditions

Appendix B, “Common return codes,” on page 661 lists further combinations of primary and secondary return codes that are common to all NOF verbs.

## STOP\_DLC

---

STOP\_DLC requests CS/AIX to stop a DLC; this also stops any active ports and LSs that use the DLC.

This verb must be issued to a running node.

### VCB structure

```
typedef struct stop_dlc
{
    AP_UINT16      opcode;           /* verb operation code      */
    unsigned char  reserv2;         /* reserved                  */
    unsigned char  format;         /* reserved                  */
    AP_UINT16      primary_rc;     /* primary return code      */
    AP_UINT32      secondary_rc;   /* secondary return code    */
    unsigned char  stop_type;     /* stop type                */
    unsigned char  dlc_name[8];    /* name of DLC              */
} STOP_DLC;
```

### Supplied parameters

The application supplies the following parameters:

#### ***opcode***

AP\_STOP\_DLC

#### ***stop\_type***

Type of stop processing required. Possible values are:

##### **AP\_ORDERLY\_STOP**

CS/AIX will perform cleanup operations before stopping the DLC.

##### **AP\_IMMEDIATE\_STOP**

CS/AIX will stop the DLC immediately.

#### ***dlc\_name***

Name of DLC to be stopped. This is an 8-byte ASCII string, padded on the right with spaces if the name is shorter than 8 bytes, which must already have been defined by a DEFINE\_DLC verb.

### Returned parameters: successful execution

If the verb executes successfully, CS/AIX returns the following parameters:

#### ***primary\_rc***

AP\_OK

### Returned parameters: parameter check

If the verb does not execute because of a parameter error, CS/AIX returns the following parameters:

**primary\_rc**

AP\_PARAMETER\_CHECK

**secondary\_rc**

Possible values are:

**AP\_INVALID\_DLC**The *dlc\_name* parameter did not match the name of a defined DLC.**AP\_UNRECOGNIZED\_DEACT\_TYPE**The *stop\_type* parameter was not set to a valid value.

Appendix B, “Common return codes,” on page 661 lists further secondary return codes associated with AP\_PARAMETER\_CHECK, which are common to all NOF verbs.

**Returned parameters: state check**

If the verb does not execute because of a state error, CS/AIX returns the following parameters.

**primary\_rc**

AP\_STATE\_CHECK

**secondary\_rc****AP\_STOP\_DLC\_PENDING**

The specified DLC is already in the process of being stopped.

Appendix B, “Common return codes,” on page 661 lists further secondary return codes associated with AP\_STATE\_CHECK, which are common to all NOF verbs.

**Returned parameters: cancelled**

If the verb does not execute because it has been cancelled, CS/AIX returns the following parameters:

**primary\_rc****AP\_CANCELLED**

The *stop\_type* parameter specified an orderly stop, but the DLC was then stopped by a second command specifying an immediate stop or by a failure condition.

**Returned parameters: other conditions**

Appendix B, “Common return codes,” on page 661 lists further combinations of primary and secondary return codes that are common to all NOF verbs.

**STOP\_INTERNAL\_PU**

STOP\_INTERNAL\_PU requests DLUR to initiate SSCP-PU session deactivation for a previously defined local PU which is served by DLUR.

This verb must be issued to a running node.

**VCB structure**

```
typedef struct stop_internal_pu
{
    AP_UINT16      opcode;           /* verb operation code      */
    unsigned char  reserv2;         /* reserved                  */
    unsigned char  format;         /* reserved                  */
    AP_UINT16      primary_rc;     /* primary return code      */
    AP_UINT32      secondary_rc;   /* secondary return code    */
    unsigned char  pu_name[8];    /* internal PU name        */
    unsigned char  stop_type;     /* type of stop requested   */
} STOP_INTERNAL_PU;
```

## Supplied parameters

The application supplies the following parameters:

***opcode***

AP\_STOP\_INTERNAL\_PU

***pu\_name***

Name of the internal PU for which the SSCP-PU session will be deactivated. This is an 8-byte type-A EBCDIC string (starting with a letter), padded to the right with EBCDIC spaces.

***stop\_type***

Specifies how to stop the PU. Possible values are:

**AP\_ORDERLY\_STOP**

Deactivate all underlying PLU-SLU and SSCP-LU sessions before deactivating the SSCP-PU session.

**AP\_IMMEDIATE\_STOP**

Deactivate the SSCP-PU session immediately.

## Returned parameters: successful execution

If the verb executes successfully, CS/AIX returns the following parameters:

***primary\_rc***

AP\_OK

## Returned parameters: parameter check

If the verb does not execute because of a parameter error, CS/AIX returns the following parameters:

***primary\_rc***

AP\_PARAMETER\_CHECK

***secondary\_rc*****AP\_INVALID\_STOP\_TYPE**

The *stop\_type* parameter was not set to a valid value.

## Returned parameters: state check

If the verb does not execute because of a state error, CS/AIX returns the following parameters.

***primary\_rc***

AP\_STATE\_CHECK

***secondary\_rc***

Possible values are:

**AP\_PU\_NOT\_DEFINED**

The supplied PU name did not match the name of a defined internal PU.

**AP\_PU\_ALREADY\_DEACTIVATING**

The PU is already in the process of being stopped.

**AP\_PU\_NOT\_ACTIVE**

The PU is not active.

## Returned parameters: function not supported

If the verb does not execute because the node's configuration does not support it, CS/AIX returns the following parameter:

**primary\_rc****AP\_FUNCTION\_NOT\_SUPPORTED**

The node does not support DLUR; this is defined by the *dlur\_supported* parameter on DEFINE\_NODE.

**Returned parameters: other conditions**

Appendix B, “Common return codes,” on page 661 lists further combinations of primary and secondary return codes that are common to all NOF verbs.

**STOP\_LS**

STOP\_LS stops an active LS. Alternatively, it can be issued for an inactive LS, to specify that the LS cannot be activated automatically by CS/AIX when required or activated by the remote system; if both of these are disabled, the LS can be activated only by issuing START\_LS.

This verb must be issued to a running node.

**VCB structure**

```
typedef struct stop_ls
{
    AP_UINT16      opcode;           /* verb operation code          */
    unsigned char  reserv2;         /* reserved                      */
    unsigned char  format;         /* reserved                      */
    AP_UINT16      primary_rc;     /* primary return code          */
    AP_UINT32      secondary_rc;   /* secondary return code        */
    unsigned char  stop_type;      /* stop type                    */
    unsigned char  ls_name[8];     /* name of link station         */
    unsigned char  disable;        /* disable remote or auto activation? */
    unsigned char  reserved[3];    /* reserved                      */
} STOP_LS;
```

**Supplied parameters**

The application supplies the following parameters:

**opcode**

AP\_STOP\_LS

**stop\_type**

Type of stop processing required. Possible values are:

**AP\_ORDERLY\_STOP**

CS/AIX will perform cleanup operations before stopping the LS.

**AP\_IMMEDIATE\_STOP**

CS/AIX will stop the LS immediately.

**ls\_name**

Name of LS to be stopped. This is an 8-byte ASCII string, padded on the right with spaces if the name is shorter than 8 bytes, which must already have been defined by a DEFINE\_LS verb.

**disable**

Specifies the action to be taken for the LS.

To stop an active LS and return to the default settings for auto-activation and remote activation, set this parameter to AP\_NO.

To specify that an inactive LS cannot be activated by CS/AIX, or cannot be activated by the remote system, specify one or both of the following values (combined using a logical OR):

**AP\_AUTO\_ACT**

The LS cannot be activated automatically by CS/AIX.

## STOP\_PORT

### AP\_REMOTE\_ACT

The LS cannot be activated by the remote system. This value does not alter the defined value of *disable\_remote\_act* in the LS definition; when the LS is next started and stopped, it will return to the defined setting.

## Returned parameters: successful execution

If the verb executes successfully, CS/AIX returns the following parameters:

**primary\_rc**  
AP\_OK

## Returned parameters: parameter check

If the verb does not execute because of a parameter error, CS/AIX returns the following parameters:

**primary\_rc**  
AP\_PARAMETER\_CHECK

**secondary\_rc**  
Possible values are:

### AP\_LINK\_NOT\_DEFD

The *ls\_name* parameter did not match the name of a defined LS.

### AP\_UNRECOGNIZED\_DEACT\_TYPE

The *stop\_type* parameter was not set to a valid value.

Appendix B, “Common return codes,” on page 661 lists further secondary return codes associated with AP\_PARAMETER\_CHECK, which are common to all NOF verbs.

## Returned parameters: state check

If the verb does not execute because of a state error, CS/AIX returns the following parameters.

**primary\_rc**  
AP\_STATE\_CHECK

**secondary\_rc**

### AP\_LINK\_DEACT\_IN\_PROGRESS

The specified LS is already in the process of being deactivated.

Appendix B, “Common return codes,” on page 661 lists further secondary return codes associated with AP\_STATE\_CHECK, which are common to all NOF verbs.

## Returned parameters: cancelled

If the verb does not execute because it was cancelled, CS/AIX returns the following parameters.

**primary\_rc**

### AP\_CANCELLED

The *stop\_type* parameter specified an orderly stop, but the LS was then stopped by a second verb specifying an immediate stop or by a failure condition.

## Returned parameters: other conditions

Appendix B, “Common return codes,” on page 661 lists further combinations of primary and secondary return codes that are common to all NOF verbs.

## STOP\_PORT

---

STOP\_PORT allows the application to stop a port. This also stops any active LSs that are using the port.

This verb must be issued to a running node.

## VCB structure

```
typedef struct stop_port
{
    AP_UINT16      opcode;           /* verb operation code      */
    unsigned char  reserv2;         /* reserved                  */
    unsigned char  format;         /* reserved                  */
    AP_UINT16      primary_rc;     /* primary return code      */
    AP_UINT32      secondary_rc;   /* secondary return code    */
    unsigned char  stop_type;      /* Stop Type                */
    unsigned char  port_name[8];   /* name of port             */
} STOP_PORT;
```

## Supplied parameters

The application supplies the following parameters:

### ***opcode***

AP\_STOP\_PORT

### ***stop\_type***

Type of stop processing required. Possible values are:

#### **AP\_ORDERLY\_STOP**

CS/AIX will perform cleanup operations before stopping the port.

#### **AP\_IMMEDIATE\_STOP**

CS/AIX will stop the port immediately.

### ***port\_name***

Name of port to be stopped. This is an 8-byte ASCII string, padded on the right with spaces if the name is shorter than 8 bytes.

## Returned parameters: successful execution

If the verb executes successfully, CS/AIX returns the following parameters:

### ***primary\_rc***

AP\_OK

## Returned parameters: parameter check

If the verb does not execute because of a parameter error, CS/AIX returns the following parameters:

### ***primary\_rc***

AP\_PARAMETER\_CHECK

### ***secondary\_rc***

Possible values are:

#### **AP\_INVALID\_PORT\_NAME**

The *port\_name* parameter did not match the name of a defined port.

#### **AP\_UNRECOGNIZED\_DEACT\_TYPE**

The *stop\_type* parameter was not set to a valid value.

Appendix B, “Common return codes,” on page 661 lists further secondary return codes associated with AP\_PARAMETER\_CHECK, which are common to all NOF verbs.

## Returned parameters: state check

If the verb does not execute because of a state error, CS/AIX returns the following parameters.

### ***primary\_rc***

AP\_STATE\_CHECK

## TERM\_NODE

### *secondary\_rc*

#### **AP\_STOP\_PORT\_PENDING**

The specified port is already in the process of being deactivated.

Appendix B, “Common return codes,” on page 661 lists further secondary return codes associated with AP\_STATE\_CHECK, which are common to all NOF verbs.

## Returned parameters: cancelled

If the verb does not execute because it has been cancelled, CS/AIX returns the following parameters:

### *primary\_rc*

#### **AP\_CANCELLED**

The *stop\_type* parameter specified an orderly stop, but the port was then stopped by a second verb specifying an immediate stop or by a failure condition.

## Returned parameters: other conditions

Appendix B, “Common return codes,” on page 661 lists further combinations of primary and secondary return codes that are common to all NOF verbs.

## TERM\_NODE

---

TERM\_NODE allows the application to stop the node with a specified urgency. This also stops all connectivity resources associated with the node.

This verb must be issued to a running node.

## VCB structure

```
typedef struct term_node
{
    AP_UINT16      opcode;          /* verb operation code    */
    unsigned char  reserv2;        /* reserved               */
    unsigned char  format;        /* reserved               */
    AP_UINT16      primary_rc;     /* primary return code    */
    AP_UINT32      secondary_rc;   /* secondary return code  */
    unsigned char  stop_type;     /* stop type              */
} TERM_NODE;
```

## Supplied parameters

The application supplies the following parameters:

### *opcode*

AP\_TERM\_NODE

### *stop\_type*

Specifies how CS/AIX should stop the node. Possible values are:

#### **AP\_ABORT**

Stop immediately without attempting any cleanup processing. This value should be used only in serious error conditions, because it may cause problems for other programs using the node's resources.

#### **AP\_SHUTDOWN**

Deactivate all LSs associated with the node before stopping.

#### **AP QUIESCE**

Indicate to the network that the node is quiesced, reset session limits on all modes, unbind all endpoint sessions for the node's LUs, and then stop as for AP\_SHUTDOWN.



**AP\_QUIESCE\_ISR**

Same functions as AP\_QUIESCE, except that the node waits for all intermediate sessions to end. This value applies only to network nodes.

**AP\_DEACT\_CLEAN**

Same functions as AP\_QUIESCE, except that session limits are not reset and RTP connections are allowed to terminate gracefully before the LSs are deactivated.

**Returned parameters: successful execution**

If the verb executes successfully, CS/AIX returns the following parameters:

*primary\_rc*  
AP\_OK

**Returned parameters: other conditions**

Appendix B, “Common return codes,” on page 661 lists further combinations of primary and secondary return codes that are common to all NOF verbs.

**UNREGISTER\_INDICATION\_SINK**

UNREGISTER\_INDICATION\_SINK unregisters the NOF application so that it no longer receives indications of a particular type (previously specified using REGISTER\_INDICATION\_SINK).

If the application has registered more than once to accept multiple indication types, it must unregister separately for each indication that it no longer wants to receive.

This verb must always be issued using the asynchronous NOF API entry point, including the callback routine that was supplied on the REGISTER\_INDICATION\_SINK verb (for more information about the asynchronous NOF API entry point, see “Asynchronous entry point: nof\_async” on page 21).

This verb may be issued to the domain configuration file, to a running node or to a server where the node is not running, or to the sna.net file, depending on the type of indication for which the application is unregistering.

**VCB structure**

```
typedef struct unregister_indication_sink
{
    AP_UINT16      opcode;           /* verb operation code          */
    unsigned char  reserv2;         /* reserved                     */
    unsigned char  format;          /* reserved                     */
    AP_UINT16      primary_rc;      /* primary return code          */
    AP_UINT32      secondary_rc;    /* secondary return code        */
    AP_UINT32      proc_id;         /* reserved                     */
    AP_UINT16      queue_id;        /* reserved                     */
    AP_UINT16      indication_opcode; /* opcode of indication to be unsunk */
} UNREGISTER_INDICATION_SINK;
```

**Supplied parameters**

The application supplies the following parameters:

***opcode***

AP\_UNREGISTER\_INDICATION\_SINK

***indication\_opcode***

The *opcode* parameter of the indication that is no longer required.

**Returned parameters: successful execution**

If the verb executes successfully, CS/AIX returns the following parameters:

***primary\_rc***

AP\_OK

## Returned parameters: parameter check

If the verb does not execute because of a parameter error, CS/AIX returns the following parameters:

***primary\_rc***

AP\_PARAMETER\_CHECK

***secondary\_rc***

**AP\_INVALID\_OP\_CODE**

The *indication\_opcode* parameter did not match the *opcode* of any of the CS/AIX NOF indications, or the application has not previously registered to receive the specified indication on this target handle.

Appendix B, “Common return codes,” on page 661 lists further secondary return codes associated with AP\_PARAMETER\_CHECK, which are common to all NOF verbs.

## Returned parameters: function not supported

If the verb does not execute successfully because the local node does not support the function associated with the specified indication, CS/AIX returns the following parameters:

***primary\_rc***

**AP\_FUNCTION\_NOT\_SUPPORTED**

The local node does not support the specified indication. For details of the support required for each indication, see the description of each indication in [Chapter 4, “NOF Indications,”](#) on page 599.

## Returned parameters: other conditions

Appendix B, “Common return codes,” on page 661 lists further combinations of primary and secondary return codes that are common to all NOF verbs.

## Chapter 4. NOF Indications

This chapter provides the following information for each NOF indication:

- Description of the indication's purpose and usage
- Verb control block (VCB) structure, as defined in the NOF API header file `/usr/include/sna/nof_c.h` (AIX) or `/opt/ibm/sna/include/nof_c.h` (Linux)
- Explanations of the parameters returned to the application in the VCB

For information about how the application registers to receive NOF indications, see [“REGISTER\\_INDICATION\\_SINK” on page 553](#).

### CONFIG\_INDICATION

This indication is generated when another NOF application or a CS/AIX administration tool makes a change to the target configuration, when the target node is stopped or started, or when a DLC, port, or LS owned by the target node is stopped or started. The target can be the domain configuration file, a running node, or an inactive node on a server where the CS/AIX software is running. The target is identified by the *target\_handle* parameter on the REGISTER\_INDICATION\_SINK verb that registers to receive this indication.

#### VCB structure

No specific VCB structure is associated with this indication. To register for configuration indications, the application specifies the value AP\_CONFIG\_INDICATION as the *indication\_opcode* parameter on REGISTER\_INDICATION\_SINK. When a change is made, CS/AIX then reports this to the application's callback routine by sending a copy of the VCB from the NOF verb that made the change. For example, if the configuration was modified by a DEFINE\_DLC verb, CS/AIX sends a copy of the DEFINE\_DLC VCB to the application's callback routine.

To enable the application to distinguish between configuration indications and asynchronous responses to its own NOF verbs, CS/AIX changes the *primary\_rc* parameter in the VCB for a configuration indication. The value AP\_INDICATION identifies a VCB associated with a configuration indication; the value AP\_OK, or any other value, indicates an asynchronous response to one of the application's own NOF verbs.

The following events are not reported as configuration indications:

- Changes to the SNA network file `sna.net`. To receive indications of these changes, the application must register for the indication type AP\_SNA\_NET\_INDICATION. For more information, see [“SNA\\_NET\\_INDICATION” on page 648](#).
- Starting and stopping the SNA software on other servers. To receive indications of these changes, the application must register for the indication type AP\_SERVER\_INDICATION. For more information, see [“SERVER\\_INDICATION” on page 644](#).

The range of VCBs that can be returned as configuration indications depends on the type of target handle specified on REGISTER\_INDICATION\_SINK:

#### Domain configuration file

The application can receive VCBs for any verbs that modify domain resources but not node resources (verbs that can be issued to the domain configuration file).

#### Node configuration file

The application can receive VCBs for any verbs that modify node resources.

#### Running node

The application can receive VCBs for any verbs that modify node resources, TERM\_NODE VCBs, and START\_\* and STOP\_\* VCBs for DLCs, ports, and LSs.

## DIRECTORY\_INDICATION

### Inactive node

The application can receive VCBs for any verbs that modify node resources and also INIT\_NODE VCBs.

## DIRECTORY\_INDICATION

This indication is generated when an entry is added to or removed from the local directory database.

### VCB structure

```
typedef struct directory_indication
{
    AP_UINT16      opcode;                /* verb operation code          */
    unsigned char  reserv2;              /* reserved                     */
    unsigned char  format;              /* reserved                     */
    AP_UINT16      primary_rc;          /* primary return code          */
    AP_UINT32      secondary_rc;        /* secondary return code        */
    unsigned char  data_lost;           /* previous indication lost     */
    unsigned char  removed;            /* is entry being removed?     */
    unsigned char  resource_name[17];   /* resource name                */
    unsigned char  invalid;            /* invalid entry being removed? */
    AP_UINT16      resource_type;       /* resource type                */
    unsigned char  parent_name[17];    /* parent resource name         */
    unsigned char  entry_type;         /* type of the directory entry  */
    AP_UINT16      parent_type;        /* parent resource type         */
    unsigned char  description[32];    /* resource description         */
    unsigned char  reserv3[16];        /* reserved                     */
    AP_UINT16      real_owning_cp_type; /* CP type of real owner       */
    unsigned char  real_owning_cp_name[17]; /* CP name of real owner     */
    AP_UINT16      supplier_cp_type;   /* CP type of supplier         */
    unsigned char  supplier_cp_name[17]; /* CP name of supplier        */
    unsigned char  reserva;            /* reserved                     */
} DIRECTORY_INDICATION;
```

### Parameters

#### *opcode*

AP\_DIRECTORY\_INDICATION

#### *primary\_rc*

AP\_OK

#### *data\_lost*

Specifies whether any previous directory indications have been lost. If CS/AIX detects a condition that prevents it from sending an indication (for example an internal resource shortage), it indicates this by setting the *data\_lost* parameter on the next indication after the condition has cleared. Possible values are:

#### **AP\_YES**

One or more previous directory indications were lost. Later fields in this VCB may be set to zeros.

#### **AP\_NO**

No previous directory indications were lost.

#### *removed*

Specifies whether the indicated resource has been removed from the directory or added to it. Possible values are:

#### **AP\_YES**

The entry has been removed.

#### **AP\_NO**

The entry has been added.

#### *resource\_name*

Fully qualified name of the resource. The name is a 17-byte EBCDIC string, padded on the right with EBCDIC spaces. It consists of a network ID of up to 8 A-string characters, an EBCDIC dot (period) character, and a network name of up to 8 A-string characters.

***invalid***

When an end node registers its resources with a network node, new directory entries are added to the network node's directory database for these resources. If the database already contains an explicitly defined entry for one of these resources, but the entry does not match the registered resource, CS/AIX removes the entry that is not valid and replaces it with the correct entry. This parameter is used to indicate whether the entry has been removed because it was not valid and has been replaced by the correct entry from the registered resource or because it was explicitly deleted. Possible values are:

**AP\_YES**

The entry has been removed because it was incorrect.

**AP\_NO**

The entry has been removed because it was explicitly deleted.

If the local node is not a network node, or if *removed* is set to AP\_NO, this parameter is not used.

***resource\_type***

Resource type. Possible values are:

**AP\_NNCP\_RESOURCE**

Network node.

**AP\_ENCP\_RESOURCE**

End node.

**AP\_LU\_RESOURCE**

LU.

***parent\_name***

Fully qualified name of parent resource. If *resource\_type* is AP\_NNCP\_RESOURCE, this is set to 17 binary zeros.

The name is a 17-byte EBCDIC string, padded on the right with EBCDIC spaces. It consists of a network ID of up to 8 A-string characters, an EBCDIC dot (period) character, and a network name of up to 8 A-string characters.

***entry\_type***

Specifies the type of the directory entry. This is one of the following:

**AP\_HOME**

Local resource.

**AP\_CACHE**

Cached entry.

**AP\_REGISTER**

Registered resource (NN only)

***parent\_type***

Specifies the parent type of the resource being registered. If *resource\_type* is AP\_NNCP\_RESOURCE, this parameter is not used. Possible values are:

**AP\_NNCP\_RESOURCE**

Network node.

**AP\_ENCP\_RESOURCE**

End node.

***description***

A null-terminated text string describing the resource, as specified in the definition of the resource.

***real\_owning\_cp\_type***

This parameter applies only if the local node is a Network Node or a Branch Network Node; it is reserved otherwise.

Specifies whether the real CP that owns the resource identified by this directory entry is the parent resource or another node. This is one of the following:

## DLC\_INDICATION

### AP\_NONE

The real owner is the parent resource.

### AP\_ENCP\_RESOURCE

The real owner is an end node that is not the parent resource. For example, if the resource is owned by an End Node in the domain of a Branch Network Node (BrNN), the directory of this BrNN's Network Node Server includes the BrNN as the parent resource, but the real owning CP is the End Node.

### *real\_owning\_cp\_name*

This parameter applies only if the local node is a Network Node or a Branch Network Node; it is reserved otherwise.

If the *real\_owning\_cp\_type* parameter indicates that the real owner of the resource is not the parent, this parameter specifies the fully qualified name of the CP that owns the resource; otherwise it is reserved.

The name is a 17-byte EBCDIC string, padded on the right with EBCDIC spaces. It consists of a network ID of 1-8 A-string characters, an EBCDIC dot (period) character, and a network name of 1-8 A-string characters.

### *supplier\_cp\_type*

This parameter applies only if the local node is a Network Node or a Branch Network Node; it is reserved otherwise.

Specifies whether this directory entry was registered by another node that is not the owning CP of the resource. This is one of the following:

### AP\_NONE

The directory entry was not registered, or was registered by its owning CP.

### AP\_ENCP\_RESOURCE

The directory entry was registered by a node that is not its owning CP. For example, if the resource is owned by an End Node in the domain of a Branch Network Node (BrNN) that is itself in the domain of the local node, the BrNN is the supplier because it registers the resource with the local node, but the real owning CP is the End Node.

### *supplier\_cp\_name*

This parameter applies only if the local node is a Network Node or a Branch Network Node; it is reserved otherwise.

If the *supplier\_cp\_type* parameter indicates that the directory entry was registered by a node that is not the owning resource, this parameter specifies the fully qualified name of the CP that supplied the registration; otherwise it is reserved.

The name is a 17-byte EBCDIC string, padded on the right with EBCDIC spaces. It consists of a network ID of 1-8 A-string characters, an EBCDIC dot (period) character, and a network name of 1-8 A-string characters.

## DLC\_INDICATION

---

This indication is generated when a DLC changes state between active and inactive.

### VCB structure

```
typedef struct dlc_indication
{
    AP_UINT16      opcode;                /* verb operation code          */
    unsigned char  reserv2;              /* reserved                      */
    unsigned char  format;               /* reserved                      */
    AP_UINT16      primary_rc;           /* primary return code          */
    AP_UINT32      secondary_rc;         /* secondary return code        */
    unsigned char  data_lost;            /* previous indication lost      */
    unsigned char  deactivated;          /* has session been deactivated? */
    unsigned char  dlc_name[8];          /* link station name            */
    unsigned char  description[32];      /* resource description          */
    unsigned char  reserv1[16];          /* reserved                      */
}
```

```

    unsigned char   reserva[20];           /* reserved                */
} DLC_INDICATION;

```

## Parameters

### *opcode*

AP\_DLC\_INDICATION

### *primary\_rc*

AP\_OK

### *data\_lost*

Specifies whether any previous indications have been lost. If CS/AIX detects a condition that prevents it from sending an indication (for example an internal resource shortage), it indicates this by setting the *data\_lost* parameter on the next indication after the condition has cleared. Possible values are:

#### **AP\_YES**

One or more previous DLC indications were lost. Later fields in this VCB may be set to zeros.

#### **AP\_NO**

No previous DLC indications were lost.

### *deactivated*

Specifies whether the DLC has become inactive or become active. Possible values are:

#### **AP\_YES**

The DLC has become inactive.

#### **AP\_NO**

The DLC has become active.

### *dlc\_name*

Name of DLC. This is an 8-byte ASCII string, padded on the right with spaces if the name is shorter than 8 bytes.

### *description*

A null-terminated text string describing the DLC, as specified in the definition of the DLC.

## DLUR\_LU\_INDICATION

This indication is generated when a DLUR LU is activated or deactivated. This indication can be used by a registered application to maintain a list of currently active DLUR LUs.

## VCB structure

```

typedef struct dlur_lu_indication
{
    AP_UINT16      opcode;           /* Indication operation code */
    unsigned char  reserv2;         /* reserved                   */
    unsigned char  format;         /* reserved                   */
    AP_UINT16      primary_rc;     /* primary return code       */
    AP_UINT32      secondary_rc;   /* secondary return code     */
    unsigned char  data_lost;     /* Previous indication lost? */
    unsigned char  reason;        /* reason for this indication */
    unsigned char  lu_name[8];    /* LU name                   */
    unsigned char  pu_name[8];   /* PU name                   */
    unsigned char  nau_address;  /* NAU address               */
    unsigned char  reserv5[7];    /* reserved                   */
} DLUR_LU_INDICATION;

```

## Parameters

### *opcode*

AP\_DLUR\_LU\_INDICATION

### *primary\_rc*

AP\_OK

## DLUR\_PU\_INDICATION

### *data\_lost*

Specifies whether any previous directory indications have been lost. If CS/AIX detects a condition that prevents it from sending an indication (for example an internal resource shortage), it indicates this by setting the *data\_lost* parameter on the next indication after the condition has cleared. Possible values are:

#### **AP\_YES**

One or more previous directory indications were lost. Later fields in this VCB may be set to zeros.

#### **AP\_NO**

No previous directory indications were lost.

### *reason*

Reason for this indication. Possible values are:

#### **AP\_ADDED**

The DLUR has just been activated by the DLUS.

#### **AP\_REMOVED**

The DLUR has been deactivated, either explicitly by the DLUS or implicitly by a link failure or the deactivation of the PU.

### *lu\_name*

Name of the logical unit (LU). This is an 8-byte alphanumeric type-A EBCDIC string (starting with a letter), padded on the right with EBCDIC spaces.

### *pu\_name*

Name of the physical unit (PU) that this LU uses. This is an 8-byte alphanumeric type-A EBCDIC string (starting with a letter), padded on the right with EBCDIC spaces.

### *nau\_address*

Network accessible unit (NAU) address of the LU. This value must be in the range 1-255.

## DLUR\_PU\_INDICATION

---

This indication is generated when a physical unit (PU) for the node that supports the dependent LU requester (DLUR) function is attempting to activate, fails to activate, activates, or is deactivated. This indication can be used to maintain a list of currently active DLUR PUs.

## VCB structure

```
typedef struct dlur_pu_indication
{
    AP_UINT16      opcode;                /* Indication operation code      */
    unsigned char  reserv2;               /* reserved                        */
    unsigned char  format;               /* reserved                        */
    AP_UINT16      primary_rc;           /* primary return code            */
    AP_UINT32      secondary_rc;         /* secondary return code          */
    unsigned char  data_lost;            /* Previous indication lost?      */
    unsigned char  reason;               /* reason for this indication     */
    unsigned char  pu_name[8];           /* PU name                        */
    unsigned char  pu_id[4];             /* PU identifier                  */
    unsigned char  pu_location;          /* downstream or local PU        */
    unsigned char  pu_status;            /* status of the PU              */
    unsigned char  dlus_name[17];        /* current DLUS name             */
    unsigned char  dlus_session_status; /* status of the DLUS pipe       */
    unsigned char  reserv5[2];           /* reserved                       */
} DLUR_PU_INDICATION;
```

## Parameters

### *opcode*

AP\_DLUR\_PU\_INDICATION

### *primary\_rc*

AP\_OK



***data\_lost***

Specifies whether any previous directory indications have been lost. If CS/AIX detects a condition that prevents it from sending an indication (for example an internal resource shortage), it indicates this by setting the *data\_lost* parameter on the next indication after the condition has cleared. Possible values are:

**AP\_YES**

One or more previous directory indications were lost. Later fields in this VCB may be set to zeros.

**AP\_NO**

No previous directory indications were lost.

***reason***

Cause of the indication. Possible values are:

Possible values are:

**AP\_ACTIVATION\_STARTED**

The PU is activating.

**AP\_ACTIVATING**

The PU has become active.

**AP\_DEACTIVATING**

The PU has become inactive.

**AP\_FAILED**

The PU has failed.

**AP\_ACTIVATION\_FAILED**

The PU has failed to activate.

***pu\_name***

Name of the physical unit (PU). This is an 8-byte alphanumeric type-A EBCDIC string (starting with a letter), padded on the right with EBCDIC spaces.

***pu\_id***

PU identifier defined in a DEFINE\_INTERNAL\_PU verb or obtained in an XID from a downstream PU. This value is a 4-byte hexadecimal string. Bits 0-11 are set to the Block number and bits 12-31 are set to the ID number that uniquely identifies the PU.

***pu\_location***

Location of the PU. Possible values are:

**AP\_INTERNAL**

The PU has been defined by a DEFINE\_INTERNAL\_PU verb.

**AP\_DOWNSTREAM**

The PU is located at a downstream computer.

***pu\_status***

Status of the PU, as seen by the DLUR. Possible values are:

**AP\_RESET\_NO\_RETRY**

The PU is in reset state and will not be retried.

**AP\_RESET\_RETRY**

The PU is in reset state and will be retried.

**AP\_PEND\_ACTPU**

The PU is waiting for an ACTPU from the host.

**AP\_PEND\_ACTPU\_RSP**

Having forwarded an ACTPU to the PU, DLUR is now waiting for the PU to respond to it.

**AP\_ACTIVE**

The PU is active.

**AP\_PEND\_DACTPU\_RSP**

Having forwarded a DACTPU to the PU, DLUR is now waiting for the PU to respond to it.

## DLUS\_INDICATION

### AP\_PEND\_INOP

DLUR is waiting for all necessary events to complete before it deactivates the PU.

### *dlius\_name*

Name of the dependent LU server (DLUS) node that the PU is currently using (or attempting to use). The name is a 17-byte EBCDIC string, padded on the right with EBCDIC spaces. It consists of a network ID of up to 8 A-string characters, an EBCDIC dot (period) character, and a network name of up to 8 A-string characters. If the *reason* parameter is set to AP\_FAILED, the *dlius\_name* parameter is set to all zeros.

### *dlius\_session\_status*

Status of the DLUS pipe currently being used by the PU. Possible values are:

#### AP\_PENDING\_ACTIVE

The DLUS pipe is currently being activated.

#### AP\_ACTIVE

The DLUS pipe is active.

#### AP\_PENDING\_INACTIVE

The DLUS pipe is currently being deactivated.

#### AP\_INACTIVE

The DLUS pipe is inactive.

## DLUS\_INDICATION

This indication is generated when a pipe to a DLUS node changes state between active and inactive. When the pipe becomes inactive, the indication also includes pipe statistics.

### VCB structure

```
typedef struct dlius_indication
{
    AP_UINT16      opcode;                /* verb operation code          */
    unsigned char  reserv2;              /* reserved                     */
    unsigned char  format;              /* reserved                     */
    AP_UINT16      primary_rc;          /* primary return code          */
    AP_UINT32      secondary_rc;        /* secondary return code        */
    unsigned char  data_lost;           /* previous indication lost     */
    unsigned char  deactivated;         /* has DLUS become inactive?   */
    unsigned char  dlius_name[17];     /* DLUS name                    */
    unsigned char  reserv1;            /* reserved                     */
    PIPE_STATS     pipe_stats;          /* pipe statistics              */
    unsigned char  persistent_pipe_support; /* reserved                    */
    unsigned char  persistent_pipe;    /* reserved                     */
    unsigned char  reserva[18];        /* reserved                     */
} DLUS_INDICATION;
```

```
typedef struct pipe_stats
{
    AP_UINT32      reqactpu_sent;        /* REQACTPUs sent to DLUS      */
    AP_UINT32      reqactpu_rsp_received; /* RSP(REQACTPU)s received    */
    /* from DLUS */
    AP_UINT32      actpu_received;      /* ACTPUs received from DLUS  */
    AP_UINT32      actpu_rsp_sent;      /* RSP(ACTPU)s sent to DLUS   */
    AP_UINT32      reqdactpu_sent;     /* REQDACTPUs sent to DLUS    */
    AP_UINT32      reqdactpu_rsp_received; /* RSP(REQDACTPU)s received  */
    /* from DLUS */
    AP_UINT32      dactpu_received;     /* DACTPUs received from DLUS */
    AP_UINT32      dactpu_rsp_sent;     /* RSP(DACTPU)s sent to DLUS  */
    AP_UINT32      actlu_received;     /* ACTLUs received from DLUS  */
    AP_UINT32      actlu_rsp_sent;     /* RSP(ACTLU)s sent to DLUS   */
    AP_UINT32      dactlu_received;    /* DACTLUs received from DLUS */
    AP_UINT32      dactlu_rsp_sent;    /* RSP(DACTLU)s sent to DLUS  */
    AP_UINT32      sscp_pu_mus_rcvd;   /* MUS for SSCP-PU sessions rcvd */
    AP_UINT32      sscp_pu_mus_sent;   /* MUS for SSCP-PU sessions sent */
    AP_UINT32      sscp_lu_mus_rcvd;   /* MUS for SSCP-LU sessions rcvd */
    AP_UINT32      sscp_lu_mus_sent;   /* MUS for SSCP-LU sessions sent */
} PIPE_STATS;
```

## Parameters

### ***opcode***

AP\_DLUS\_INDICATION

### ***primary\_rc***

AP\_OK

### ***data\_lost***

Specifies whether any previous DLUS indications have been lost. If CS/AIX detects a condition that prevents it from sending an indication (for example an internal resource shortage), it indicates this by setting the *data\_lost* parameter on the next indication after the condition has cleared. Possible values are:

#### **AP\_YES**

One or more previous downstream LU indications were lost. Later fields in this VCB may be set to zeros.

#### **AP\_NO**

No previous downstream LU indications were lost.

### ***deactivated***

Specifies whether the pipe has become inactive or become active. Possible values are:

#### **AP\_YES**

The pipe has become inactive.

#### **AP\_NO**

The pipe has become active.

### ***dlus\_name***

Name of the DLUS node. The name is a 17-byte EBCDIC string, right-padded with EBCDIC spaces. It consists of a network ID of up to 8 A-string characters, an EBCDIC dot (period) character, and a network name of up to 8 A-string characters.

If the pipe was deactivated, a *pipe\_stats* structure is included. The fields in this structure are as follows:

#### ***pipe\_stats.reqactpu\_sent***

Number of REQACTPUs sent to DLUS over the pipe.

#### ***pipe\_stats.reqactpu\_rsp\_received***

Number of RSP(REQACTPU)s received from DLUS over the pipe.

#### ***pipe\_stats.actpu\_received***

Number of ACTPUs received from DLUS over the pipe.

#### ***pipe\_stats.actpu\_rsp\_sent***

Number of RSP(ACTPU)s sent to DLUS over the pipe.

#### ***pipe\_stats.reqdactpu\_sent***

Number of REQDACTPUs sent to DLUS over the pipe.

#### ***pipe\_stats.reqdactpu\_rsp\_received***

Number of RSP(REQDACTPU)s received from DLUS over the pipe.

#### ***pipe\_stats.dactpu\_received***

Number of DACTPUs received from DLUS over the pipe.

#### ***pipe\_stats.dactpu\_rsp\_sent***

Number of RSP(DACTPU)s sent to DLUS over the pipe.

#### ***pipe\_stats.actlu\_received***

Number of ACTLUs received from DLUS over the pipe.

#### ***pipe\_stats.actlu\_rsp\_sent***

Number of RSP(ACTLU)s sent to DLUS over the pipe.

#### ***pipe\_stats.dactlu\_received***

Number of DACTLUs received from DLUS over the pipe.

## DOWNSTREAM\_LU\_INDICATION

### *pipe\_stats.dactlu\_rsp\_sent*

Number of RSP(DACTLU)s sent to DLUS over the pipe.

### *pipe\_stats.sscp\_pu\_mus\_rcvd*

Number of SSCP-PU MUs received from DLUS over the pipe.

### *pipe\_stats.sscp\_pu\_mus\_sent*

Number of SSCP-PU MUs sent to DLUS over the pipe.

### *pipe\_stats.sscp\_lu\_mus\_rcvd*

Number of SSCP-LU MUs received from DLUS over the pipe.

### *pipe\_stats.sscp\_lu\_mus\_sent*

Number of SSCP-LU MUs sent to DLUS over the pipe.

## DOWNSTREAM\_LU\_INDICATION

This indication is generated when either the LU-SSCP session or the PLU-SLU session between the downstream LU and the host changes state between active and inactive. When one of these sessions becomes inactive, the indication also includes session statistics for that session.

### VCB structure

```
typedef struct downstream_lu_indication
{
    AP_UINT16      opcode;                /* verb operation code          */
    unsigned char  reserv2;               /* reserved                     */
    unsigned char  format;                /* reserved                     */
    AP_UINT16      primary_rc;            /* primary return code          */
    AP_UINT32      secondary_rc;          /* secondary return code        */
    unsigned char  data_lost;             /* previous indication lost     */
    unsigned char  dspu_name[8];          /* PU name                      */
    unsigned char  ls_name[8];            /* Link station name            */
    unsigned char  dslu_name[8];          /* LU name                      */
    unsigned char  description[32];        /* resource description         */
    unsigned char  reserv3[16];           /* reserved                     */
    unsigned char  nau_address;            /* NAU address                  */
    unsigned char  lu_sscp_sess_active;    /* Is LU-SSCP session active    */
    unsigned char  plu_sess_active;        /* Is PLU-SLU session active    */
    unsigned char  dspu_services;          /* DSPU services                */
    unsigned char  reserv1;               /* reserved                     */
    SESSION_STATS lu_sscp_stats;           /* LU-SSCP session statistics   */
    SESSION_STATS ds_plu_stats;            /* Downstream PLU-SLU session stats */
    SESSION_STATS us_plu_stats;            /* Upstream PLU-SLU session stats */
} DOWNSTREAM_LU_INDICATION;
```

```
typedef struct session_stats
{
    AP_UINT16      rcv_ru_size;            /* session receive RU size      */
    AP_UINT16      send_ru_size;           /* session send RU size         */
    AP_UINT16      max_send_btu_size;      /* maximum send BTU size        */
    AP_UINT16      max_rcv_btu_size;       /* maximum rcv BTU size         */
    AP_UINT16      max_send_pac_win;        /* maximum send pacing window size */
    AP_UINT16      cur_send_pac_win;        /* current send pacing window size */
    AP_UINT16      max_rcv_pac_win;         /* maximum receive pacing window size */
    AP_UINT16      cur_rcv_pac_win;         /* current receive pacing window size */
    AP_UINT32      send_data_frames;        /* number of data frames sent   */
    AP_UINT32      send_fmd_data_frames;    /* num fmd data frames sent     */
    AP_UINT32      send_data_bytes;         /* number of data bytes sent     */
    AP_UINT32      rcv_data_frames;         /* number of data frames received */
    AP_UINT32      rcv_fmd_data_frames;     /* num fmd data frames received  */
    AP_UINT32      rcv_data_bytes;          /* number of data bytes received */
    unsigned char  sidh;                   /* session ID high byte (from LFSID) */
    unsigned char  sidl;                   /* session ID low byte (from LFSID) */
    unsigned char  odai;                   /* ODAI bit set                 */
    unsigned char  ls_name[8];              /* Link station name            */
    unsigned char  reserve;                /* reserved                     */
} SESSION_STATS;
```

## Parameters

### ***opcode***

AP\_DOWNSTREAM\_LU\_INDICATION

### ***primary\_rc***

AP\_OK

### ***data\_lost***

Specifies whether any previous downstream LU indications have been lost. If CS/AIX detects a condition that prevents it from sending an indication (for example an internal resource shortage), it indicates this by setting the *data\_lost* parameter on the next indication after the condition has cleared. Possible values are:

#### **AP\_YES**

One or more previous downstream LU indications were lost. Later fields in this VCB may be set to zeros.

#### **AP\_NO**

No previous downstream LU indications were lost.

### ***dspu\_name***

Name of the downstream PU associated with the downstream LU. This is an 8-byte alphanumeric type-A EBCDIC string (starting with a letter), padded on the right with EBCDIC spaces.

### ***ls\_name***

Name of the link station associated with the downstream LU. This is an 8-byte ASCII string, padded on the right with spaces if the name is shorter than 8 characters.

### ***dslu\_name***

Name of the downstream LU. This is an 8-byte alphanumeric type-A EBCDIC string (starting with a letter), padded on the right with EBCDIC spaces.

### ***description***

A null-terminated text string describing the downstream LU, as specified in the definition of the LU.

### ***nau\_address***

Network accessible unit address of the LU.

### ***lu\_sscp\_sess\_active***

Specifies whether the LU-SSCP session is active. Possible values are:

#### **AP\_YES**

The session is active.

#### **AP\_NO**

The session is not active.

### ***plu\_sess\_active***

Specifies whether the PLU-SLU session is active. Possible values are:

#### **AP\_YES**

The session is active.

#### **AP\_NO**

The session is not active.

### ***dspu\_services***

Specifies the services provided by the local node to the downstream LU.

Possible values are:

#### **AP\_PU\_CONCENTRATION**

Downstream LU is served by SNA gateway.

#### **AP\_DLUR**

Downstream LU is served by DLUR.

## DOWNSTREAM\_LU\_INDICATION

If the LU-SSCP session was deactivated, a `session_stats` structure is included for this session; if the PLU-SLU session was deactivated, `session_stats` structures are included for the downstream and upstream PLU-SLU sessions. The fields in this structure are as follows:

***rcv\_ru\_size***

Maximum receive RU size. (In the LU-SSCP session statistics, this parameter is reserved.)

***send\_ru\_size***

Maximum send RU size. (In the LU-SSCP session statistics, this parameter is reserved.)

***max\_send\_btu\_size***

Maximum BTU size that can be sent.

***max\_rcv\_btu\_size***

Maximum BTU size that can be received.

***max\_send\_pac\_win***

Maximum size of the send pacing window on this session. (In the LU-SSCP session statistics, this parameter is reserved.)

***cur\_send\_pac\_win***

Current size of the send pacing window on this session. (In the LU-SSCP session statistics, this parameter is reserved.)

***max\_rcv\_pac\_win***

Maximum size of the receive pacing window on this session. (In the LU-SSCP session statistics, this parameter is reserved.)

***cur\_rcv\_pac\_win***

Current size of the receive pacing window on this session. (In the LU-SSCP session statistics, this parameter is reserved.)

***send\_data\_frames***

Number of normal flow data frames sent.

***send\_fmd\_data\_frames***

Number of normal flow FMD data frames sent.

***send\_data\_bytes***

Number of normal flow data bytes sent.

***rcv\_data\_frames***

Number of normal flow data frames received.

***rcv\_fmd\_data\_frames***

Number of normal flow FMD data frames received.

***rcv\_data\_bytes***

Number of normal flow data bytes received.

***sidh***

Session ID high byte. (In the upstream PLU-SLU session statistics, this parameter is reserved.)

***sidl***

Session ID low byte. (In the upstream PLU-SLU session statistics, this parameter is reserved.)

***odai***

Origin Destination Assignor Indicator. When bringing up a session, the sender of the BIND sets this field to zero if the local node contains the primary link station, and sets it to one if the BIND sender is the node containing the secondary link station. (In the upstream PLU-SLU session statistics, this parameter is reserved.)

***ls\_name***

Link station name associated with statistics. This is an 8-byte ASCII character string, right-padded with spaces if the name is shorter than 8 characters. (In the upstream PLU-SLU session statistics, this parameter is reserved if `dspu_services` is set to `AP_PU_CONCENTRATION`.)

## DOWNSTREAM\_PU\_INDICATION

This indication is generated when the PU-SSCP session between the downstream PU and the host changes state between active and inactive. When the session becomes inactive, the indication also includes PU-SSCP session statistics.

### VCB structure

```
typedef struct downstream_pu_indication
{
    AP_UINT16      opcode;                /* verb operation code          */
    unsigned char  reserv2;               /* reserved                      */
    unsigned char  format;               /* reserved                      */
    AP_UINT16      primary_rc;           /* primary return code          */
    AP_UINT32      secondary_rc;         /* secondary return code        */
    unsigned char  data_lost;            /* previous indication lost     */
    unsigned char  dspu_name[8];         /* PU name                      */
    unsigned char  description[32];      /* resource description         */
    unsigned char  reserv3[16];          /* reserved                      */
    unsigned char  ls_name[8];           /* Link station name           */
    unsigned char  pu_sscp_sess_active;  /* Is PU-SSCP session active    */
    unsigned char  dspu_services;        /* DSPU services                */
    unsigned char  reserv1[2];           /* reserved                      */
    SESSION_STATS  pu_sscp_stats;        /* PU-SSCP session statistics   */
} DOWNSTREAM_PU_INDICATION;
```

```
typedef struct session_stats
{
    AP_UINT16      rcv_ru_size;           /* session receive RU size      */
    AP_UINT16      send_ru_size;          /* session send RU size         */
    AP_UINT16      max_send_btu_size;     /* maximum send BTU size       */
    AP_UINT16      max_rcv_btu_size;      /* maximum rcv BTU size        */
    AP_UINT16      max_send_pac_win;      /* maximum send pacing window  */
    AP_UINT16      cur_send_pac_win;      /* current send pacing window   */
    AP_UINT16      max_rcv_pac_win;       /* maximum receive pacing window*/
    AP_UINT16      cur_rcv_pac_win;       /* current receive pacing window*/
    AP_UINT32      send_data_frames;      /* number of data frames sent   */
    AP_UINT32      send_fmd_data_frames;  /* num fmd data frames sent     */
    AP_UINT32      send_data_bytes;       /* number of data bytes sent    */
    AP_UINT32      rcv_data_frames;       /* number of data frames received */
    AP_UINT32      rcv_fmd_data_frames;   /* num fmd data frames received */
    AP_UINT32      rcv_data_bytes;        /* number of data bytes received */
    unsigned char  sidh;                  /* session ID high byte (from LFSID) */
    unsigned char  sidl;                  /* session ID low byte (from LFSID) */
    unsigned char  odai;                  /* ODAI bit set                 */
    unsigned char  ls_name[8];            /* Link station name            */
    unsigned char  reserve;               /* reserved                      */
} SESSION_STATS;
```

### Parameters

#### **opcode**

AP\_DOWNSTREAM\_PU\_INDICATION

#### **primary\_rc**

AP\_OK

#### **data\_lost**

Specifies whether any previous downstream PU indications have been lost. If CS/AIX detects a condition that prevents it from sending an indication (for example an internal resource shortage), it indicates this by setting the *data\_lost* parameter on the next indication after the condition has cleared. Possible values are:

#### **AP\_YES**

One or more previous downstream PU indications were lost. Later fields in this VCB may be set to zeros.

#### **AP\_NO**

No previous downstream PU indications were lost.

## DOWNSTREAM\_PU\_INDICATION

### ***dspu\_name***

Name of downstream PU. The name is an 8-byte EBCDIC type-A string, padded on the right with EBCDIC spaces if the name is shorter than 8 characters.

### ***description***

A null-terminated text string describing the downstream PU, as specified in the definition of the LS associated with the PU.

### ***ls\_name***

Name of the link station associated with the downstream PU. This is an 8-byte ASCII string, padded on the right with spaces if the name is shorter than 8 characters.

### ***pu\_sscp\_sess\_active***

Specifies whether the PU-SSCP session to the downstream PU is active. Possible values are:

#### **AP\_YES**

The session is active.

#### **AP\_NO**

The session is not active.

### ***dspu\_services***

Specifies the services provided by the local node to the downstream PU.

Possible values are:

#### **AP\_PU\_CONCENTRATION**

Downstream LU is served by SNA gateway.

#### **AP\_DLUR**

Downstream LU is served by DLUR.

### ***pu\_sscp\_stats.rcv\_ru\_size***

Reserved (always set to zero).

### ***pu\_sscp\_stats.send\_ru\_size***

Reserved (always set to zero).

### ***pu\_sscp\_stats.max\_send\_btu\_size***

Maximum BTU size that can be sent.

### ***pu\_sscp\_stats.max\_rcv\_btu\_size***

Maximum BTU size that can be received.

### ***pu\_sscp\_stats.max\_send\_pac\_win***

Reserved (always set to zero).

### ***pu\_sscp\_stats.cur\_send\_pac\_win***

Reserved (always set to zero).

### ***pu\_sscp\_stats.max\_rcv\_pac\_win***

Reserved (always set to zero).

### ***pu\_sscp\_stats.cur\_rcv\_pac\_win***

Reserved (always set to zero).

### ***pu\_sscp\_stats.send\_data\_frames***

Number of normal flow data frames sent.

### ***pu\_sscp\_stats.send\_fmd\_data\_frames***

Number of normal flow FMD data frames sent.

### ***pu\_sscp\_stats.send\_data\_bytes***

Number of normal flow data bytes sent.

### ***pu\_sscp\_stats.rcv\_data\_frames***

Number of normal flow data frames received.

### ***pu\_sscp\_stats.rcv\_fmd\_data\_frames***

Number of normal flow FMD data frames received.



***pu\_sscp\_stats.rcv\_data\_bytes***

Number of normal flow data bytes received.

***pu\_sscp\_stats.sidh***

Session ID high byte.

***pu\_sscp\_stats.sidl***

Session ID low byte.

***pu\_sscp\_stats.odai***

Origin Destination Assignor Indicator. When bringing up a session, the sender of the BIND sets this field to zero if the local node contains the primary link station, and sets it to one if the BIND sender is the node containing the secondary link station.

***pu\_sscp\_stats.ls\_name***

Link station name associated with statistics. This is an 8-byte ASCII character string, right-padded with spaces if the name is shorter than 8 characters.

## FOCAL\_POINT\_INDICATION

---

This indication is generated whenever a focal point is acquired, changed or revoked.

### VCB structure

```
typedef struct focal_point_indication
{
    AP_UINT16      opcode;           /* verb operation code          */
    unsigned char  reserv2;         /* reserved                     */
    unsigned char  format;         /* reserved                     */
    AP_UINT16      primary_rc;     /* primary return code         */
    AP_UINT32      secondary_rc;   /* secondary return code       */
    unsigned char  data_lost;      /* previous indication lost     */
    unsigned char  ms_category[8]; /* Focal point category        */
    unsigned char  fp_fqcp_name[17]; /* Fully qualified focal point cp name*/
    unsigned char  ms_appl_name[8]; /* Focal point application name */
    unsigned char  fp_type;        /* type of current focal point  */
    unsigned char  fp_status;      /* status of focal point        */
    unsigned char  fp_routing;     /* type of MDS routing to reach FP */
    unsigned char  reserva[20];    /* reserved                     */
} FOCAL_POINT_INDICATION;
```

### Parameters

***opcode***

AP\_FOCAL\_POINT\_INDICATION

***primary\_rc***

AP\_OK

***data\_lost***

Specifies whether any previous focal point indications have been lost. If CS/AIX detects a condition that prevents it from sending an indication (for example an internal resource shortage), it indicates this by setting the *data\_lost* parameter on the next indication after the condition has cleared. Possible values are:

**AP\_YES**

One or more previous focal point indications were lost. Later fields in this VCB may be set to zeros.

**AP\_NO**

No previous focal point indications were lost.

***ms\_category***

Management Services category for which the focal point has changed. This can be either one of the category names specified in the MS Discipline-Specific Application Programs table contained in the *SNA Management Services Reference*, padded on the right with spaces if the name is shorter than 8 bytes, or a user-defined category. User-defined category names should be an 8-byte type-1134 EBCDIC string, padded on the right with spaces if the name is shorter than 8 bytes.

***fp\_fqcp\_name***

Fully qualified name of the current focal point for the specified MS category. The name is a 17-byte EBCDIC string, padded on the right with EBCDIC spaces. It consists of a network ID of up to 8 A-string characters, an EBCDIC dot (period) character, and a network name of up to 8 A-string characters. If this parameter is set to 17 binary zeros, this indicates that there is no focal point currently defined for the specified MS category; the previous focal point has been deleted and not replaced.

***ms\_appl\_name***

Name of the current focal point application. This can be either one of the application names specified in the MS Discipline-Specific Application Programs table in *Systems Network Architecture: Management Services Reference SC30-3346*, padded on the right with spaces to 8 bytes, or a user-defined application name (see the Bibliography). User-defined names should be an 8-byte type-1134 EBCDIC string, padded on the right with spaces if the name is shorter than 8 bytes. If this parameter is set to 8 binary zeros, this indicates that there is no focal point currently defined for the specified MS category; the previous focal point has been deleted and not replaced.

***fp\_type***

Type of focal point. Refer to SNA Management Services for further detail. Possible values are:

AP\_EXPLICIT\_PRIMARY\_FP

AP\_IMPLICIT\_PRIMARY\_FP

AP\_BACKUP\_FP

AP\_DEFAULT\_PRIMARY\_FP

AP\_DOMAIN\_FP

AP\_HOST\_FP

AP\_NO\_FP

***fp\_status***

Status of the focal point. Possible values are:

**AP\_NOT\_ACTIVE**

The focal point has gone from active to inactive.

**AP\_ACTIVE**

The focal point has gone from inactive or pending active to active.

***fp\_routing***

Type of routing that applications should specify when sending data to the focal point. This parameter is used only if the focal point status is AP\_ACTIVE. Possible values are:

**AP\_DEFAULT**

Data should be sent using default routing.

**AP\_DIRECT**

Data should be sent using direct routing.

## ISR\_INDICATION

---

This indication is generated when an intermediate session routing (ISR) session is activated or deactivated. When the session is deactivated, the returned data includes statistics on the session's usage.

### VCB structure

```
typedef struct isr_indication
{
    AP_UINT16      opcode;                /* verb operation code          */
    unsigned char  reserv2;              /* reserved                     */
    unsigned char  format;              /* reserved                     */
    AP_UINT16      primary_rc;          /* primary return code         */
    AP_UINT32      secondary_rc;        /* secondary return code       */
    unsigned char  data_lost;           /* previous indication lost     */
}
```

```

unsigned char   deactivated;           /* has ISR session been          */
/* deactivated?                          */
FQPCID         fqpcid;                /* FQPCID for ISR session        */
unsigned char   fqplu_name[17];       /* fully-qualified primary LU name */
unsigned char   fqslu_name[17];       /* fully-qualified secondary      */
/* LU name                                */
unsigned char   mode_name[8];         /* mode name                      */
unsigned char   cos_name[8];          /* COS name                       */
unsigned char   transmission_priority; /* transmission priority          */
AP_UINT32       sense_data;           /* sense data                      */
unsigned char   reserv2a[2];          /* reserved                        */
SESSION_STATS   pri_sess_stats;       /* Primary hop session statistics */
SESSION_STATS   sec_sess_stats;       /* Secondary hop session statistics*/
unsigned char   reserva[20];          /* reserved                        */
} ISR_INDICATION;

```

```

typedef struct fqpcid
{
  unsigned char   pcid[8];             /* procedure correlator identifier */
  unsigned char   fqcp_name[17];       /* originator's network qualified  */
/* CP name                                */
  unsigned char   reserve3[3];         /* reserved                        */
} FQPCID;

```

```

typedef struct session_stats
{
  AP_UINT16       rcv_ru_size;         /* session receive RU size        */
  AP_UINT16       send_ru_size;        /* session send RU size           */
  AP_UINT16       max_send_btu_size;   /* maximum send BTU size          */
  AP_UINT16       max_rcv_btu_size;    /* maximum rcv BTU size           */
  AP_UINT16       max_send_pac_win;    /* maximum send pacing window size */
  AP_UINT16       cur_send_pac_win;    /* current send pacing window size */
  AP_UINT16       max_rcv_pac_win;     /* maximum receive pacing window size*/
  AP_UINT16       cur_rcv_pac_win;     /* current receive pacing window size*/
  AP_UINT32       send_data_frames;    /* number of data frames sent     */
  AP_UINT32       send_fmd_data_frames; /* num fmd data frames sent       */
  AP_UINT32       send_data_bytes;     /* number of data bytes sent      */
  AP_UINT32       rcv_data_frames;     /* number of data frames received */
  AP_UINT32       rcv_fmd_data_frames; /* num fmd data frames received   */
  AP_UINT32       rcv_data_bytes;      /* number of data bytes received  */
  unsigned char   sidh;                /* session ID high byte (from LFSID) */
  unsigned char   sidl;                /* session ID low byte (from LFSID) */
  unsigned char   odai;                /* ODAI bit set                   */
  unsigned char   ls_name[8];          /* Link station name              */
  unsigned char   reserve;             /* reserved                        */
} SESSION_STATS;

```

## Parameters

### ***opcode***

AP\_ISR\_INDICATION

### ***primary\_rc***

AP\_OK

### ***data\_lost***

Specifies whether any previous ISR indications have been lost. If CS/AIX detects a condition that prevents it from sending an indication (for example an internal resource shortage), it indicates this by setting the *data\_lost* parameter on the next indication after the condition has cleared. Possible values are:

#### **AP\_YES**

One or more previous ISR indications were lost. Later fields in this VCB may be set to zeros.

#### **AP\_NO**

No previous ISR indications were lost.

### ***deactivated***

Specifies whether the ISR session was deactivated or activated. Possible values are:

#### **AP\_YES**

The session was deactivated.

**AP\_NO**

The session was activated.

***fqpcid.pcid***

Procedure Correlator ID for the session. This is an 8-byte hexadecimal string.

***fqpcid.fqcp\_name***

Fully qualified control point name. The name is a 17-byte EBCDIC string, padded on the right with EBCDIC spaces. It consists of a network ID of up to 8 A-string characters, an EBCDIC dot (period) character, and a network name of up to 8 A-string characters.

***fqplu\_name***

Fully qualified name of the primary LU for this session; this parameter is reserved if *deactivated* is set to AP\_YES. The name is a 17-byte EBCDIC string, padded on the right with EBCDIC spaces. It consists of a network ID of up to 8 A-string characters, an EBCDIC dot (period) character, and a network name of up to 8 A-string characters.

***fqslu\_name***

Fully qualified name of the secondary LU for this session; this parameter is reserved if *deactivated* is set to AP\_YES. The name is a 17-byte EBCDIC string, padded on the right with EBCDIC spaces. It consists of a network ID of up to 8 A-string characters, an EBCDIC dot (period) character, and a network name of up to 8 A-string characters.

***mode\_name***

Mode name for this session; this parameter is reserved if *deactivated* is set to AP\_YES. This is an 8-byte type-A EBCDIC string (starting with a letter), padded to the right with EBCDIC spaces.

***cos\_name***

COS name for this session; this parameter is reserved if *deactivated* is set to AP\_YES. This is an 8-byte type-A EBCDIC string (starting with a letter), padded to the right with EBCDIC spaces.

***transmission\_priority***

The transmission priority associated with the session. This parameter is reserved if *deactivated* is set to AP\_YES.

***sense\_data***

The sense data sent or received on the UNBIND request. This parameter is reserved if *deactivated* is set to AP\_NO.

If the ISR session was deactivated, *session\_stats* structures are included for the primary and secondary sessions. The fields in this structure are as follows:

***rcv\_ru\_size***

Maximum receive RU size.

***send\_ru\_size***

Maximum send RU size.

***max\_send\_btu\_size***

Maximum BTU size that can be sent.

***max\_rcv\_btu\_size***

Maximum BTU size that can be received.

***max\_send\_pac\_win***

Maximum size of the send pacing window on this session.

***cur\_send\_pac\_win***

Current size of the send pacing window on this session.

***max\_rcv\_pac\_win***

Maximum size of the receive pacing window on this session.

***cur\_rcv\_pac\_win***

Current size of the receive pacing window on this session.

***send\_data\_frames***

Number of normal flow data frames sent.

**send\_fmd\_data\_frames**

Number of normal flow FMD data frames sent.

**send\_data\_bytes**

Number of normal flow data bytes sent.

**rcv\_data\_frames**

Number of normal flow data frames received.

**rcv\_fmd\_data\_frames**

Number of normal flow FMD data frames received.

**rcv\_data\_bytes**

Number of normal flow data bytes received.

**sidh**

Session ID high byte.

**sidl**

Session ID low byte.

**odai**

Origin Destination Assignor Indicator. When bringing up a session, the sender of the BIND sets this field to zero if its local node contains the primary link station, and sets it to one if its local node contains the secondary link station.

**ls\_name**

Link station name associated with statistics. This is an 8-byte ASCII string, padded on the right with spaces if the name is shorter than 8 bytes, which can be used to correlate the session statistics with the link over which the session traffic flows.

## LOCAL\_LU\_INDICATION

---

This indication is generated when a local LU is defined or deleted. This indication can be used by a registered application to maintain a list of all local LUs currently defined.

### VCB structure

```
typedef struct local_lu_indication
{
    AP_UINT16      opcode;           /* Indication operation code      */
    unsigned char  reserv2;         /* reserved                        */
    unsigned char  format;         /* reserved                        */
    AP_UINT16      primary_rc;     /* primary return code            */
    AP_UINT32      secondary_rc;   /* secondary return code          */
    unsigned char  data_lost;      /* Previous indication lost?      */
    unsigned char  reason;         /* reason for this indication     */
    unsigned char  lu_name[8];     /* LU name                        */
    DESCRIPTION    description;    /* resource description           */
    unsigned char  lu_alias[8];    /* LU alias                       */
    unsigned char  nau_address;    /* NAU address                    */
    unsigned char  reserv4;        /* reserved                        */
    unsigned char  pu_name[8];     /* PU name                        */
    unsigned char  lu_sscp_active; /* Is LU-SSCP session active     */
    unsigned char  reserv5;        /* reserved                        */
    SESSION_STATS  lu_sscp_stats;  /* LU-SSCP session statistics    */
    unsigned char  sscp_id[6];     /* SSCP ID                        */
} LOCAL_LU_INDICATION;
```

```
typedef struct session_stats
{
    AP_UINT16      rcv_ru_size;     /* session receive RU size        */
    AP_UINT16      send_ru_size;    /* session send RU size           */
    AP_UINT16      max_send_btu_size; /* max send BTU size             */
    AP_UINT16      max_rcv_btu_size; /* max receive BTU size          */
    AP_UINT16      max_send_pac_win; /* max send pacing window size   */
    AP_UINT16      cur_send_pac_win; /* current send pacing window size */
    AP_UINT16      max_rcv_pac_win; /* max receive pacing window size */
    AP_UINT16      cur_rcv_pac_win; /* current rcv pacing window size */
    AP_UINT32      send_data_frames; /* number of data frames sent    */
    AP_UINT32      send_fmd_data_frames; /* num of fmd data frames sent */
    AP_UINT32      send_data_bytes; /* number of data bytes sent     */
}
```

## LOCAL\_LU\_INDICATION

```
AP_UINT32      rcv_data_frames;      /* number of data frames received */
AP_UINT32      rcv_fmd_data_frames; /* num of fmd data frames received */
AP_UINT32      rcv_data_bytes;      /* number of data bytes received */
unsigned char  sidh;                /* session ID high byte */
unsigned char  sidl;                /* session ID low byte */
unsigned char  odai;                /*origin-destination assignor bit set*/
unsigned char  ls_name[8];          /* link station name */
unsigned char  pacing_type;         /* type of pacing in use */
} SESSION_STATS;
```

The LU-SSCP statistics contained in the `session_stats` structure are valid only when both the `nau_address` parameter is set to a nonzero value and the `lu_sscp_active` parameter is set to `AP_YES`. Otherwise, the parameters in the `session_stats` structure are reserved.

## Parameters

### **opcode**

`AP_LOCAL_LU_INDICATION`

### **primary\_rc**

`AP_OK`

### **data\_lost**

Specifies whether any previous directory indications have been lost. If CS/AIX detects a condition that prevents it from sending an indication (for example an internal resource shortage), it indicates this by setting the `data_lost` parameter on the next indication after the condition has cleared. Possible values are:

#### **AP\_YES**

One or more previous directory indications were lost. Later fields in this VCB may be set to zeros.

#### **AP\_NO**

No previous directory indications were lost.

### **reason**

Reason for the indication. Possible values are:

#### **AP\_ADDED**

The LU has been defined.

#### **AP\_REMOVED**

The LU has been deleted, either explicitly using `DELETE_LOCAL_LU`, or implicitly, using `DELETE_LS`, `DELETE_PORT`, or `DELETE_DLC`.

#### **AP\_SSCP\_ACTIVE**

The LU-SSCP session has become active after the node has successfully processed an `ACTLU`.

#### **AP\_SSCP\_INACTIVE**

The LU-SSCP session has become inactive after a normal `DACTLU` or a link failure.

### **lu\_name**

Name of the local logical unit (LU) whose state has changed. This is an 8-byte alphanumeric type-A EBCDIC string (starting with a letter), padded on the right with EBCDIC spaces.

### **description**

Resource description, as specified on `DEFINE_LOCAL_LU`.

### **lu\_alias**

Locally defined LU alias. This is an 8-byte string in a locally displayable character set. All eight bytes are significant.

### **nau\_address**

Network accessible unit (NAU) address of the LU. This value must be in the range 1-255. A nonzero value implies that the LU is a dependent LU. The value 0 (zero) implies that the LU is an independent LU.

### **pu\_name**

Name of the physical unit (PU) that this LU uses. This is an 8-byte type-A EBCDIC string, padded on the right with EBCDIC spaces. This parameter is significant only if the `nau_address` parameter is not

set to 0 (zero). If the *nau\_address* parameter is set to 0, the *pu\_name* parameter is set to all binary zeros.

***lu\_sscp\_sess\_active***

Specifies whether the LU-SSCP session is active. If the *nau\_address* parameter is set to 0 (zero), this parameter is reserved. Possible values are:

**AP\_YES**

The LU-SSCP session is active.

**AP\_NO**

The LU-SSCP session is not active.

***lu\_sscp\_stats.rcv\_ru\_size***

This parameter is always reserved.

***lu\_sscp\_stats.send\_ru\_size***

This parameter is always reserved.

***lu\_sscp\_stats.max\_send\_btu\_size***

Maximum basic transmission unit (BTU) that can be sent.

***lu\_sscp\_stats.max\_rcv\_btu\_size***

Maximum basic transmission unit (BTU) that can be received.

***lu\_sscp\_stats.max\_send\_pac\_win***

This parameter is always set to zero.

***lu\_sscp\_stats.cur\_send\_pac\_win***

This parameter is always set to zero.

***lu\_sscp\_stats.max\_rcv\_pac\_win***

This parameter is always set to zero.

***lu\_sscp\_stats.cur\_rcv\_pac\_win***

This parameter is always set to zero.

***lu\_sscp\_stats.send\_data\_frames***

Number of normal flow data frames sent.

***lu\_sscp\_stats.send\_fmd\_data\_frames***

Number of normal flow function management data (FMD) frames sent.

***lu\_sscp\_stats.send\_data\_bytes***

Number of normal flow data bytes sent.

***lu\_sscp\_stats.rcv\_data\_frames***

Number of normal flow data frames received.

***lu\_sscp\_stats.rcv\_fmd\_data\_frames***

Number of normal flow function management data (FMD) frames received.

***lu\_sscp\_stats.rcv\_data\_bytes***

Number of normal flow data bytes received.

***lu\_sscp\_stats.sidh***

Session ID high byte.

***lu\_sscp\_stats.sidl***

Session ID low byte.

***lu\_sscp\_stats.odai***

Origin Destination Assignor indicator. When activating a session, the sender of the ACTLU sets this parameter to zero if the local node contains the primary link station and sets it to one if the ACTLU sender is the node containing the secondary link station.

***lu\_sscp\_stats.ls\_name***

Link station name associated with statistics. This is an 8-byte string in a locally displayable character set. All eight bytes are significant. The parameter can be used to correlate this session with the link over which the session flows.

## LOCAL\_TOPOLOGY\_INDICATION

### *lu\_sscp\_stats.pacing\_type*

Receive pacing type in use on the LU-SSCP session. This will take the value AP\_NONE.

### *sscp\_id*

The identifier of the SSCP as received in the ACTPU for the PU used by this LU. This parameter is 6 bytes and is used only by dependent LUs. This parameter is set to all zeros for independent LUs or if the *lu\_sscp\_sess\_active* parameter is not set to AP\_YES.

## LOCAL\_TOPOLOGY\_INDICATION

---

This indication is generated when one of the following occurs:

- A TG in the local node's topology database changes state between active and inactive.
- A TG in the local node's topology database changes state between quiescing and not quiescing.
- A contention winner CP-CP session over a TG in the local node's topology database is activated or deactivated.

## VCB structure

```
typedef struct local_topology_indication
{
    AP_UINT16      opcode;           /* verb operation code          */
    unsigned char  reserv2;         /* reserved                     */
    unsigned char  format;         /* reserved                     */
    AP_UINT16      primary_rc;     /* primary return code          */
    AP_UINT32      secondary_rc;   /* secondary return code        */
    unsigned char  data_lost;      /* previous indication lost     */
    unsigned char  status;         /* TG status                   */
    unsigned char  dest[17];      /* name of TG destination node  */
    unsigned char  dest_type;     /* TG destination node type    */
    unsigned char  tg_num;        /* TG number                   */
    unsigned char  cp_cp_session_active; /* CP-CP sessions active? */
    unsigned char  branch_link_type; /* Up or down link?          */
    unsigned char  branch_tg;     /* Branch TG?                  */
    unsigned char  reserva[17];   /* reserved                    */
} LOCAL_TOPOLOGY_INDICATION;
```

## Parameters

### *opcode*

AP\_LOCAL\_TOPOLOGY\_INDICATION

### *primary\_rc*

AP\_OK

### *data\_lost*

Specifies whether any previous local topology indications have been lost. If CS/AIX detects a condition that prevents it from sending an indication (for example an internal resource shortage), it indicates this by setting the *data\_lost* parameter on the next indication after the condition has cleared. Possible values are:

#### **AP\_YES**

One or more previous local topology indications were lost.

#### **AP\_NO**

No previous local topology indications were lost.

### *status*

Specifies the status of the TG. This can be AP\_NONE or one or more of the following values (combined using a logical OR):

AP\_TG\_OPERATIVE

AP\_TG\_CP\_CP\_SESSIONS

AP\_TG QUIESCING



**dest**

Fully qualified destination node name for the TG. The name is a 17-byte EBCDIC string, padded on the right with EBCDIC spaces. It consists of a network ID of up to 8 A-string characters, an EBCDIC dot (period) character, and a network name of up to 8 A-string characters.

**dest\_type**

Type of the destination node. Possible values are:

**AP\_END\_NODE**

End node.

**AP\_NETWORK\_NODE**

Network node.

**AP\_VRN**

Virtual routing node.

**tg\_num**

Transmission group number associated with the TG.

**cp\_cp\_session\_active**

Specifies whether the local node's contention winner CP-CP session is active. Possible values are:

**AP\_YES**

The CP-CP session is active.

**AP\_NO**

The CP-CP session is not active.

**AP\_UNKNOWN**

The CP-CP session status is unknown.

**branch\_link\_type**

This parameter applies only if the node is a Branch Network Node; it is reserved otherwise.

Specifies the branch link type of this TG. Possible values are:

**AP\_UPLINK**

The TG is an uplink.

**AP\_DOWNLINK**

The TG is a downlink to an End Node.

**AP\_DOWNLINK\_TO\_BRNN**

The TG is a downlink to a Branch Network Node that appears as an End Node from the perspective of the local node.

**AP\_OTHERLINK**

The TG is a link to a VRN.

**branch\_tg**

This parameter applies only if the node is a Network Node; it is reserved otherwise.

Specifies whether the TG is a branch TG. Possible values are:

**AP\_YES**

The TG is a branch TG.

**AP\_NO**

The TG is not a branch TG.

**AP\_UNKNOWN**

The TG type is unknown.

## LS\_INDICATION

---

This indication is generated when a link station is activated or deactivated. When the link station is deactivated, the returned data includes statistics on the link station's usage.

## VCB structure

```

typedef struct ls_indication
{
    AP_UINT16      opcode;                /* verb operation code          */
    unsigned char  reserv2;               /* reserved                      */
    unsigned char  format;                /* reserved                      */
    AP_UINT16      primary_rc;            /* primary return code          */
    AP_UINT32      secondary_rc;          /* secondary return code        */
    unsigned char  data_lost;             /* previous indication lost     */
    unsigned char  deactivated;           /* has LS been deactivated?     */
    unsigned char  ls_name[8];            /* link station name            */
    unsigned char  description[32];        /* resource description         */
    unsigned char  reserv1[16];           /* reserved                      */
    unsigned char  adj_cp_name[17];        /* network qualified Adjacent CP name*/
    unsigned char  adj_node_type;         /* adjacent node type           */
    AP_UINT16      act_sess_count;         /* active session count on link  */
    unsigned char  indication_cause;      /* cause of indication          */
    LS_STATS       ls_stats;              /* link station statistics      */
    unsigned char  tg_num;                 /* tg number                    */
    AP_UINT32      sense_data;            /* sense data                   */
    unsigned char  brnn_link_type;         /* type of branch link          */
    unsigned char  adj_cp_is_brnn;         /* is adjacent node a BrNN?     */
    unsigned char  mltg_member;           /* reserved                      */
    unsigned char  tg_sharing;            /* reserved                      */
    unsigned char  ls_type;               /* how LS was defined or discovered */
    unsigned char  reserva[14];           /* reserved                      */
} LS_INDICATION;

```

```

typedef struct ls_stats
{
    AP_UINT32      in_xid_bytes;           /* number of XID bytes received */
    AP_UINT32      in_msg_bytes;           /* number of message bytes received */
    AP_UINT32      in_xid_frames;          /* number of XID frames received */
    AP_UINT32      in_msg_frames;          /* number of message frames received*/
    AP_UINT32      out_xid_bytes;          /* number of XID bytes sent     */
    AP_UINT32      out_msg_bytes;          /* number of message bytes sent */
    AP_UINT32      out_xid_frames;         /* number of XID frames sent    */
    AP_UINT32      out_msg_frames;         /* number of message frames sent */
    AP_UINT32      in_invalid_sna_frames;  /* number of invalid            */
                                           /* frames received              */
    AP_UINT32      in_session_control_frames; /* number of control            */
                                           /* frames received              */
    AP_UINT32      out_session_control_frames; /* number of control            */
                                           /* frames sent                   */
    AP_UINT32      echo_rsps;              /* reserved                      */
    AP_UINT32      current_delay;           /* reserved                      */
    AP_UINT32      max_delay;              /* reserved                      */
    AP_UINT32      min_delay;              /* reserved                      */
    AP_UINT32      max_delay_time;         /* reserved                      */
    AP_UINT32      good_xids;              /* successful XID on LS count    */
    AP_UINT32      bad_xids;               /* unsuccessful XID on LS count  */
} LS_STATS;

```

## Parameters

**opcode**

AP\_LS\_INDICATION

**primary\_rc**

AP\_OK

**data\_lost**

Specifies whether any previous LS indications have been lost. If CS/AIX detects a condition that prevents it from sending an indication (for example an internal resource shortage), it indicates this by setting the *data\_lost* parameter on the next indication after the condition has cleared. Possible values are:

**AP\_YES**

One or more previous LS indications were lost. Later fields in this VCB may be set to zeros.

**AP\_NO**

No previous LS indications were lost.

***deactivated***

Specifies whether the LS has been deactivated or activated. Possible values are:

**AP\_YES**

The LS has been deactivated.

**AP\_NO**

The LS has been activated.

***ls\_name***

Name of the link station. This is an 8-byte ASCII string, padded on the right with spaces if the name is shorter than 8 bytes.

***description***

A null-terminated text string describing the LS, as specified in the definition of the LS.

***adj\_cp\_name***

Fully qualified CP name of the adjacent node. The name is a 17-byte EBCDIC string, padded on the right with EBCDIC spaces. It consists of a network ID of up to 8 A-string characters, an EBCDIC dot (period) character, and a network name of up to 8 A-string characters.

***adj\_node\_type***

Type of the adjacent node. Possible values are:

**AP\_END\_NODE**

End node.

**AP\_NETWORK\_NODE**

Network node.

**AP\_LEN\_NODE**

LEN node.

**AP\_VRN**

Virtual routing node.

***act\_sess\_count***

Total number of active sessions (both endpoint and intermediate) using the link.

***indication\_cause***

Cause of the indication. Possible values are:

**AP\_ACTIVATING**

The LS has been activated.

**AP\_DEACTIVATION\_STARTED**

Deactivation processing for the LS has started.

**AP\_DEACTIVATING**

The LS has been deactivated.

**AP\_SESS\_COUNT\_CHANGING**

The number of active sessions using the LS has changed.

**AP\_CP\_NAME\_CHANGING**

The adjacent node's CP name has changed.

**AP\_DATA\_LOST**

A previous indication could not be sent.

**AP\_FAILED**

The LS has failed.

**AP\_ACTIVATION\_STARTED**

The LS supports auto-activation, and has been started automatically when required for a session.

**AP\_ACTIVATION\_FAILED**

The LS supports auto-activation, but the attempt to start it automatically when required has failed.

**AP\_LR\_ACTIVATING**

The LS has failed (or an attempt to activate it has failed), and CS/AIX is attempting to reactivate it.

## LS\_INDICATION

The following parameters are returned only if `deactivated` is set to `AP_YES`, indicating that the LS has been deactivated.

### ***ls\_stats.in\_xid\_bytes***

Total number of XID (Exchange Identification) bytes received on this link station.

### ***ls\_stats.in\_msg\_bytes***

Total number of data bytes received on this link station.

### ***ls\_stats.in\_xid\_frames***

Total number of XID (Exchange Identification) frames received on this link station.

### ***ls\_stats.in\_msg\_frames***

Total number of data frames received on this link station.

### ***ls\_stats.out\_xid\_bytes***

Total number of XID (Exchange Identification) bytes sent on this link station.

### ***ls\_stats.out\_msg\_bytes***

Total number of data bytes sent on this link station.

### ***ls\_stats.out\_xid\_frames***

Total number of XID (Exchange Identification) frames sent on this link station.

### ***ls\_stats.out\_msg\_frames***

Total number of data frames sent on this link station.

### ***ls\_stats.in\_invalid\_sna\_frames***

Total number of SNA frames that were not valid received on this link station.

### ***ls\_stats.in\_session\_control\_frames***

Total number of session control frames received on this link station.

### ***ls\_stats.out\_session\_control\_frames***

Total number of session control frames sent on this link station.

### ***ls\_stats.good\_xids***

Total number of successful XID exchanges that have occurred on this link station since it was started.

### ***ls\_stats.bad\_xids***

Total number of unsuccessful XID exchanges that have occurred on this link station since it was started.

### ***tg\_num***

Transmission group number associated with the LS.

### ***sense\_data***

If the LS has failed because of an XID protocol error, this parameter contains the sense data associated with the error. If *indication\_cause* is set to any value other than `AP_FAILED`, this parameter is reserved.

### ***brnn\_link\_type***

This parameter applies only if the local node is a Branch Network Node; it is reserved otherwise.

Specifies the branch link type of this link. Possible values are:

#### **AP\_UPLINK**

The link is an uplink.

#### **AP\_DOWNLINK**

The link is a downlink.

#### **AP\_OTHERLINK**

The link is to a VRN.

#### **AP\_UNKNOWN\_LINK\_TYPE**

The branch link type is unknown.

#### **AP\_BRNN\_NOT\_SUPPORTED**

The link supports PU 2.0 traffic only.

**adj\_cp\_is\_brnn**

Specifies whether the adjacent node is a Branch Network Node. Possible values are:

**AP\_YES**

The adjacent node is a Branch Network Node.

**AP\_NO**

The adjacent node is not a Branch Network Node.

**AP\_UNKNOWN**

The adjacent node type is unknown.

**ls\_type**

Specifies how this link was defined or discovered. Possible values are:

**AP\_LS\_DEFINED**

The link station was defined explicitly by a CS/AIX administration program.

**AP\_LS\_DYNAMIC**

The link station was created when the local node connected to another node through a connection network.

**AP\_LS\_TEMPORARY**

The link station was created temporarily to process an incoming call, but has not yet become active.

**AP\_LS\_IMPLICIT**

The link station was defined implicitly when CS/AIX received an incoming call that it could not match to a defined link station.

**AP\_LS\_DLUS\_DEFINED**

The link station is a dynamic link station to a DLUR-served downstream PU, and was defined when the local node received an ACTPU from a DLUS.

## LU\_0\_TO\_3\_INDICATION

---

This indication is generated when the session status of a type 0-3 LU changes.

### VCB structure

```
typedef struct lu_0_to_3_indication
{
    AP_UINT16      opcode;           /* verb operation code          */
    unsigned char  reserv2;         /* reserved                      */
    unsigned char  format;         /* reserved                      */
    AP_UINT16      primary_rc;      /* primary return code          */
    AP_UINT32      secondary_rc;    /* secondary return code        */
    unsigned char  data_lost;       /* previous indication lost     */
    unsigned char  pu_name[8];     /* PU Name                      */
    unsigned char  lu_name[8];     /* LU Name                      */
    unsigned char  description[32]; /* resource description         */
    unsigned char  reserv1[16];    /* reserved                     */
    unsigned char  nau_address;     /* NAU address                  */
    unsigned char  lu_sscp_sess_active; /* Is SSCP session active?    */
    unsigned char  appl_conn_active; /* Is application using LU?    */
    unsigned char  plu_sess_active; /* Is PLU-SLU session active?  */
    unsigned char  host_attachment; /* Host attachment              */
    SESSION_STATS lu_sscp_stats;    /* LU-SSCP session statistics   */
    SESSION_STATS plu_stats;       /* PLU session statistics       */
    unsigned char  sscp_id[6];     /* SSCP id                      */
} LU_0_TO_3_INDICATION;
```

```
typedef struct session_stats
{
    AP_UINT16      rcv_ru_size;     /* session receive RU size      */
    AP_UINT16      send_ru_size;    /* session send RU size         */
    AP_UINT16      max_send_btu_size; /* maximum send BTU size       */
    AP_UINT16      max_rcv_btu_size; /* maximum rcv BTU size        */
    AP_UINT16      max_send_pac_win; /* maximum send pacing window  */
    AP_UINT16      cur_send_pac_win; /* current send pacing window   */
    AP_UINT16      max_rcv_pac_win; /* maximum receive pacing window */
}
```

## LU\_0\_TO\_3\_INDICATION

```
AP_UINT16      cur_rcv_pac_win;      /* size */
AP_UINT32      send_data_frames;    /* current receive pacing window */
AP_UINT32      send_fmd_data_frames; /* size */
AP_UINT32      send_data_bytes;     /* number of data frames sent */
AP_UINT32      rcv_data_frames;     /* num fmd data frames sent */
AP_UINT32      rcv_fmd_data_frames; /* number of data bytes sent */
AP_UINT32      rcv_data_bytes;     /* number of data frames received */
AP_UINT32      rcv_fmd_data_bytes;  /* num fmd data frames received */
AP_UINT32      rcv_data_bytes;     /* number of data bytes received */
unsigned char  sidh;                /* session ID high byte (from LFSID) */
unsigned char  sidl;                /* session ID low byte (from LFSID) */
unsigned char  odai;                /* ODAI bit set */
unsigned char  ls_name[8];          /* Link station name */
unsigned char  reserve;             /* reserved */
} SESSION_STATS;
```

## Parameters

### ***opcode***

AP\_LU\_0\_TO\_3\_INDICATION

### ***primary\_rc***

AP\_OK

### ***data\_lost***

Specifies whether any previous LU 0-3 indications have been lost. If CS/AIX detects a condition that prevents it from sending an indication (for example an internal resource shortage), it indicates this by setting the *data\_lost* parameter on the next indication after the condition has cleared. Possible values are:

#### **AP\_YES**

One or more previous LU 0-3 indications were lost. Later fields in this VCB may be set to zeros.

#### **AP\_NO**

No previous LU 0-3 indications were lost.

### ***pu\_name***

Name of the local PU used by the LU. This is an 8-byte type-A EBCDIC string (starting with a letter), padded on the right with EBCDIC spaces if the name is shorter than 8 characters.

### ***lu\_name***

Name of the LU whose session status has changed. This is an 8-byte type-A EBCDIC string, padded on the right with spaces if the name is shorter than 8 characters.

### ***description***

A null-terminated text string describing the LU, as specified in the definition of the LU.

### ***nau\_address***

Network accessible unit address of the LU.

### ***lu\_sscp\_sess\_active***

Specifies whether the SSCP session is active - that is, whether the ACTLU has been successfully processed. Possible values are:

#### **AP\_YES**

The session is active.

#### **AP\_NO**

The session is not active.

### ***appl\_conn\_active***

Specifies whether an application is using the LU. Possible values are:

#### **AP\_YES**

An application is using the LU.

#### **AP\_NO**

No application is using the LU.

### ***plu\_sess\_active***

Specifies whether the PLU-SLU session has been activated. Possible values are:

**AP\_YES**

The session is active.

**AP\_NO**

The session is not active.

**host\_attachment**

LU host attachment type.

Possible values are:

**AP\_DIRECT\_ATTACHED**

LU is directly attached to the host system.

**AP\_DLUR\_ATTACHED**

LU is attached to the host system using DLUR

**sscp\_id**

For dependent LU sessions, this parameter is the SSCP ID received in the ACTPU from the host for the PU to which the local LU is mapped. For independent LU sessions, this parameter is set to 0 (zero). This value is an array of six bytes displayed as hexadecimal values.

A session\_stats structure is included for each of the two sessions (LU-SSCP session and PLU-SLU session). If the session goes from active to inactive, the structure contains the following parameters; otherwise these parameters are reserved.

**rcv\_ru\_size**

Maximum receive RU size. (In the LU-SSCP session statistics, this parameter is reserved.)

**send\_ru\_size**

Maximum send RU size. (In the LU-SSCP session statistics, this parameter is reserved.)

**max\_send\_btu\_size**

Maximum BTU size that can be sent.

**max\_rcv\_btu\_size**

Maximum BTU size that can be received.

**max\_send\_pac\_win**

Maximum size of the send pacing window on this session. (In the LU-SSCP session statistics, this parameter is reserved.)

**cur\_send\_pac\_win**

Current size of the send pacing window on this session. (In the LU-SSCP session statistics, this parameter is reserved.)

**max\_rcv\_pac\_win**

Maximum size of the receive pacing window on this session. (In the LU-SSCP session statistics, this parameter is reserved.)

**cur\_rcv\_pac\_win**

Current size of the receive pacing window on this session. (In the LU-SSCP session statistics, this parameter is reserved.)

**send\_data\_frames**

Number of normal flow data frames sent.

**send\_fmd\_data\_frames**

Number of normal flow FMD data frames sent.

**send\_data\_bytes**

Number of normal flow data bytes sent.

**rcv\_data\_frames**

Number of normal flow data frames received.

**rcv\_fmd\_data\_frames**

Number of normal flow FMD data frames received.

**rcv\_data\_bytes**

Number of normal flow data bytes received.

## MODE\_INDICATION

### *sidh*

Session ID high byte.

### *sidl*

Session ID low byte.

### *odai*

Origin Destination Assignor Indicator. When bringing up a session, the sender of the BIND sets this field to zero if the local node contains the primary link station, and sets it to one if the BIND sender is the node containing the secondary link station.

### *ls\_name*

Link station name associated with statistics. This is an 8-byte ASCII character string, right-padded with spaces if the name is shorter than 8 characters.

## MODE\_INDICATION

---

This indication is sent when a local LU and partner LU start to communicate using a particular mode, or when the active session count for the LU-LU-mode combination changes.

### VCB structure

```
typedef struct mode_indication
{
    AP_UINT16      opcode;                /* verb operation code          */
    unsigned char  reserv2;               /* reserved                     */
    unsigned char  format;               /* reserved                     */
    AP_UINT16      primary_rc;           /* primary return code          */
    AP_UINT32      secondary_rc;         /* secondary return code        */
    unsigned char  data_lost;            /* previous indication lost     */
    unsigned char  removed;              /* is entry being removed?     */
    unsigned char  lu_alias[8];          /* LU alias                     */
    unsigned char  plu_alias[8];         /* partner LU alias             */
    unsigned char  fqplu_name[17];       /* fully qualified partner LU name */
    unsigned char  mode_name[8];         /* mode name                    */
    unsigned char  description[32];      /* resource description         */
    unsigned char  reserv1[16];          /* reserved                     */
    AP_UINT16      curr_sess_count;      /* current session count        */
    unsigned char  reserva[20];          /* reserved                     */
} MODE_INDICATION;
```

### Parameters

#### *opcode*

AP\_MODE\_INDICATION

#### *primary\_rc*

AP\_OK

#### *data\_lost*

Specifies whether any previous mode indications have been lost. If CS/AIX detects a condition that prevents it from sending an indication (for example an internal resource shortage), it indicates this by setting the *data\_lost* parameter on the next indication after the condition has cleared. Possible values are:

#### **AP\_YES**

One or more previous mode indications were lost.

#### **AP\_NO**

No previous mode indications were lost.

#### *removed*

This parameter is currently not used; a mode indication is generated only when the LUs start to use the mode, and not when they stop using it.

#### *lu\_alias*

Locally defined LU alias. This is an 8-byte ASCII string, padded on the right with spaces if the name is shorter than 8 bytes.



***plu\_alias***

Partner LU alias. This is an 8-byte ASCII string, padded on the right with spaces if the name is shorter than 8 bytes.

***fqplu\_name***

Fully qualified name of the partner LU. The name is a 17-byte EBCDIC string, padded on the right with EBCDIC spaces. It consists of a network ID of up to 8 A-string characters, an EBCDIC dot (period) character, and a network name of up to 8 A-string characters.

***mode\_name***

Mode name which designates the network properties for a group of sessions. This is an 8-byte type-A EBCDIC string (starting with a letter), padded on the right with spaces if the name is shorter than 8 characters.

***description***

A null-terminated text string describing the mode, as specified in the definition of the mode.

***curr\_sess\_count***

The number of sessions currently active for this LU-LU-mode combination.

## NN\_TOPOLOGY\_NODE\_INDICATION

---

This indication is generated when a node entry in a network node's topology database is activated or deactivated.

### VCB structure

```
typedef struct nn_topology_node_indication
{
    AP_UINT16      opcode;                /* verb operation code          */
    unsigned char  reserv2;               /* reserved                      */
    unsigned char  format;                /* reserved                      */
    AP_UINT16      primary_rc;            /* primary return code          */
    AP_UINT32      secondary_rc;          /* secondary return code        */
    unsigned char  data_lost;             /* previous indication lost     */
    unsigned char  deactivated;           /* has the node become inactive? */
    unsigned char  node_name[17];        /* node name                    */
    unsigned char  node_type;            /* node type                    */
    unsigned char  branch_aware;          /* is the node branch aware?    */
    unsigned char  reserva[19];          /* reserved                      */
} NN_TOPOLOGY_NODE_INDICATION;
```

### Parameters

***opcode***

AP\_NN\_TOPOLOGY\_NODE\_INDICATION

***primary\_rc***

AP\_OK

***data\_lost***

Specifies whether any previous NN topology node indications have been lost. If CS/AIX detects a condition that prevents it from sending an indication (for example an internal resource shortage), it indicates this by setting the *data\_lost* parameter on the next indication after the condition has cleared. Possible values are:

**AP\_YES**

One or more previous NN topology node indications were lost. Later fields in this VCB may be set to zeros.

**AP\_NO**

No previous NN topology node indications were lost.

***deactivated***

Specifies whether the node has been deactivated or activated. Possible values are:

## NN\_TOPOLOGY\_TG\_INDICATION

### AP\_YES

The node has been deactivated.

### AP\_NO

The node has been activated.

### node\_name

Network qualified node name from Network Topology Database. The name is a 17-byte EBCDIC string, padded on the right with EBCDIC spaces. It consists of a network ID of up to 8 A-string characters, an EBCDIC dot (period) character, and a network name of up to 8 A-string characters.

### node\_type

Type of the node. Possible values are:

#### AP\_NETWORK\_NODE

Network node.

#### AP\_VRN

Virtual routing node.

### branch\_aware

Specifies whether the node supports branch awareness, APPN Option Set 1120.

#### AP\_NO

The node does not support option set 1120.

#### AP\_YES

The node supports option set 1120.

## NN\_TOPOLOGY\_TG\_INDICATION

---

This indication is generated when a TG entry in a network node's topology database is activated or deactivated.

## VCB structure

```
typedef struct nn_topology_tg_indication
{
    AP_UINT16      opcode;           /* verb operation code          */
    unsigned char  reserv2;         /* reserved                     */
    unsigned char  format;         /* reserved                     */
    AP_UINT16      primary_rc;     /* primary return code         */
    AP_UINT32      secondary_rc;   /* secondary return code       */
    unsigned char  data_lost;      /* previous indication lost     */
    unsigned char  status;         /* TG status                   */
    unsigned char  owner[17];      /* name of TG owner node       */
    unsigned char  dest[17];      /* name of TG destination node */
    unsigned char  tg_num;        /* TG number                   */
    unsigned char  owner_type;     /* type of node that owns TG   */
    unsigned char  dest_type;     /* TG destination node type    */
    unsigned char  cp_cp_session_active; /* are CP-CP sessions active? */
    unsigned char  branch_tg;     /* is this a branch link?     */
    unsigned char  multilink_tg;  /* reserved                    */
    unsigned char  reserva[15];   /* reserved                    */
} NN_TOPOLOGY_TG_INDICATION;
```

## Parameters

### opcode

AP>NN\_TOPOLOGY\_TG\_INDICATION

### primary\_rc

AP\_OK

### data\_lost

Specifies whether any previous NN topology TG indications have been lost. If CS/AIX detects a condition that prevents it from sending an indication (for example an internal resource shortage), it indicates this by setting the *data\_lost* parameter on the next indication after the condition has cleared. Possible values are:

**AP\_YES**

One or more previous NN topology TG indications were lost. Later fields in this VCB may be set to zeros.

**AP\_NO**

No previous NN topology TG indications were lost.

**status**

Specifies the status of the TG. This can be AP\_NONE, or one or more of the following values (combined using a logical OR):

AP\_TG\_OPERATIVE

AP\_TG\_CP\_CP\_SESSIONS

AP\_TG QUIESCING

**owner**

Name of the TG's originating node (the CS/AIX local node name). The name is a 17-byte EBCDIC string, padded on the right with EBCDIC spaces. It consists of a network ID of up to 8 A-string characters, an EBCDIC dot (period) character, and a network name of up to 8 A-string characters.

**dest**

Fully qualified destination node name for the TG. The name is a 17-byte EBCDIC string, padded on the right with EBCDIC spaces. It consists of a network ID of up to 8 A-string characters, an EBCDIC dot (period) character, and a network name of up to 8 A-string characters.

**tg\_num**

Transmission group number associated with the TG.

**owner\_type**

Type of node that owns the TG. Possible values are:

AP\_NETWORK\_NODE

AP\_VRN

**dest\_type**

Type of the destination node for the TG. Possible values are:

AP\_NETWORK\_NODE

AP\_VRN

**cp\_cp\_session\_active**

Specifies whether the owning node's contention winner CP-CP session is active. Possible values are:

**AP\_YES**

The CP-CP session is active.

**AP\_NO**

The CP-CP session is not active.

**AP\_UNKNOWN**

The CP-CP session status is unknown.

**branch\_tg**

Specifies whether the TG is a branch TG. Possible values are:

**AP\_YES**

The TG is a branch TG.

**AP\_NO**

The TG is not a branch TG.

**AP\_UNKNOWN**

The TG type is unknown.

## NOF\_STATUS\_INDICATION

This indication is generated when the application can no longer access its connected target (because the CS/AIX software on the target computer has been stopped, or because the communications path to the target computer has failed). If the target is the domain configuration file, it is also generated if another server takes over as controller (and therefore the connected target file is no longer the controlling copy of the file).

The application does not need to register explicitly for this indication. CS/AIX will return it to any application that has registered for any type of indications on the specified target handle. If the application is currently registered to receive indications using more than one callback routine, CS/AIX returns this indication to the first routine registered.

After the application receives an indication that the target can no longer be accessed, all subsequent verbs using the relevant target handle will be rejected, apart from DISCONNECT\_NODE or CLOSE\_FILE (to end the application's connection to the target). In addition, any registrations for indications on this target handle will be lost; in order to continue receiving indications when the target becomes available, the application must reconnect to the target and reregister for the required indications.

### VCB structure

```
typedef struct nof_status_indication
{
    AP_UINT16      opcode;                /* verb operation code      */
    unsigned char  reserv2;               /* reserved                  */
    unsigned char  format;               /* reserved                  */
    AP_UINT16      primary_rc;           /* primary return code      */
    AP_UINT32      secondary_rc;         /* secondary return code    */
    AP_UINT32      status;               /* status being reported    */
    AP_UINT32      dead_target_handle;   /* Handle of dead connection */
    /* NULL for system termination */
    unsigned char  reserv1[32];          /* reserved                  */
} NOF_STATUS_INDICATION;
```

### Parameters

#### *opcode*

AP\_NOF\_STATUS\_INDICATION

#### *primary\_rc*

AP\_OK

#### *status*

Specifies the status change being reported. Possible values are:

##### **AP\_LOCAL\_ABENDED**

The CS/AIX software on the local computer has stopped. The application should not attempt to issue any more NOF verbs until the software has been restarted.

##### **AP\_TARGET\_ABENDED**

The CS/AIX software on the target computer has stopped or the communications path to it has failed.

##### **AP\_CONTROLLER\_TAKEOVER**

This value is returned only when the application is connected to the controlling configuration file (specified by the *requested\_role* parameter on OPEN\_FILE). Another server has now taken over as controller, so the target file is no longer the controlling configuration file. If the application needs to make further changes to the running configuration, it must use CLOSE\_FILE to end its connection with the file, and then issue OPEN\_FILE again to access the new controlling configuration file.

#### *dead\_target\_handle*

The target handle of the failed target or of the file that is no longer the controlling configuration file. The application should not attempt to issue any further verbs for this target handle except DISCONNECT\_NODE or CLOSE\_FILE.

If *status* is set to AP\_LOCAL\_ABENDED, this parameter is reserved.

## PLU\_INDICATION

This indication is generated when a local LU begins to communicate with a partner LU. This occurs either when the first ALLOCATE to this PLU is processed or when the first BIND is received from this PLU. The indication is also generated if the partner LU's CP name changes.

### VCB structure

```
typedef struct plu_indication
{
    AP_UINT16      opcode;                /* verb operation code      */
    unsigned char  reserv2;               /* reserved                  */
    unsigned char  format;                /* reserved                  */
    AP_UINT16      primary_rc;            /* primary return code      */
    AP_UINT32      secondary_rc;          /* secondary return code    */
    unsigned char  data_lost;             /* has previous indication  */
                                                /* been lost?               */
    unsigned char  removed;               /* is entry being removed?  */
    unsigned char  lu_alias[8];           /* LU alias                  */
    unsigned char  plu_alias[8];          /* partner LU alias         */
    unsigned char  fqplu_name[17];        /* fully qualified partner  */
                                                /* LU name                  */
    unsigned char  description[32];        /* resource description     */
    unsigned char  reserv1[16];           /* reserved                  */
    unsigned char  partner_cp_name[17];   /* partner CP name          */
    unsigned char  partner_lu_located;     /* partner CP name resolved? */
    unsigned char  reserva[20];           /* reserved                  */
} PLU_INDICATION;
```

### Parameters

#### *opcode*

AP\_PLU\_INDICATION

#### *primary\_rc*

AP\_OK

#### *data\_lost*

Specifies whether any previous PLU indications have been lost. If CS/AIX detects a condition that prevents it from sending an indication (for example an internal resource shortage), it indicates this by setting the *data\_lost* parameter on the next indication after the condition has cleared. Possible values are:

#### **AP\_YES**

One or more previous PLU indications were lost. Later fields in this VCB may be set to zeros.

#### **AP\_NO**

No previous PLU indications were lost.

#### *removed*

This parameter is currently not used; a PLU indication is generated only when the LUs start to communicate, and not when they stop communicating.

#### *lu\_alias*

Local LU alias. This is an 8-byte ASCII string, padded on the right with spaces if the name is shorter than 8 bytes.

#### *plu\_alias*

Partner LU alias. This is an 8-byte ASCII string, padded on the right with spaces if the name is shorter than 8 bytes.

#### *fqplu\_name*

17-byte fully qualified network name for the partner LU. The name is a 17-byte EBCDIC string, padded on the right with EBCDIC spaces. It consists of a network ID of up to 8 A-string characters, an EBCDIC dot (period) character, and a network name of up to 8 A-string characters.

## PORT\_INDICATION

### **description**

A null-terminated text string describing the partner LU, as specified in the definition of the partner LU.

### **partner\_cp\_name**

17-byte fully qualified network name for the CP associated with the partner LU. This parameter is not used if *partner\_lu\_located* below is set to AP\_NO.

The name is a 17-byte EBCDIC string, padded on the right with EBCDIC spaces. It consists of a network ID of up to 8 A-string characters, an EBCDIC dot (period) character, and a network name of up to 8 A-string characters.

### **partner\_lu\_located**

Specifies whether the local node has located the CP where the partner LU is located. Possible values are:

#### **AP\_YES**

The partner LU has been located. The *partner\_cp\_name* parameter contains the CP name of the partner LU.

#### **AP\_NO**

The partner LU has not yet been located. The *partner\_cp\_name* parameter should not be checked.

## PORT\_INDICATION

---

This indication is generated when a port is activated or deactivated.

## VCB structure

```
typedef struct port_indication
{
    AP_UINT16      opcode;           /* verb operation code          */
    unsigned char  reserv2;         /* reserved                      */
    unsigned char  format;         /* reserved                      */
    AP_UINT16      primary_rc;     /* primary return code          */
    AP_UINT32      secondary_rc;   /* secondary return code        */
    unsigned char  data_lost;      /* previous indication lost     */
    unsigned char  deactivated;    /* has session been deactivated? */
    unsigned char  port_name[8];   /* port name                    */
    unsigned char  description[32]; /* resource description         */
    unsigned char  reserv1[16];    /* reserved                      */
    unsigned char  reserva[20];    /* reserved                      */
} PORT_INDICATION;
```

## Parameters

### **opcode**

AP\_PORT\_INDICATION

### **primary\_rc**

AP\_OK

### **data\_lost**

Specifies whether any previous port indications have been lost. If CS/AIX detects a condition that prevents it from sending an indication (for example an internal resource shortage), it indicates this by setting the *data\_lost* parameter on the next indication after the condition has cleared. Possible values are:

#### **AP\_YES**

One or more previous port indications were lost. Later fields in this VCB may be set to zeros.

#### **AP\_NO**

No previous port indications were lost.

### **deactivated**

Specifies whether the port has been deactivated or activated. Possible values are:

**AP\_YES**

The port has been deactivated.

**AP\_NO**

The port has been activated.

**port\_name**

Name of port. This is an 8-byte ASCII string, padded on the right with spaces if the name is shorter than 8 bytes.

**description**

A null-terminated text string describing the port, as specified in the definition of the port.

## PU\_INDICATION

---

This indication is generated when the PU-SSCP session status of a local PU changes.

### VCB structure

```
typedef struct pu_indication
{
    AP_UINT16      opcode;                /* verb operation code */
    unsigned char  reserv2;               /* reserved */
    unsigned char  format;                /* reserved */
    AP_UINT16      primary_rc;            /* primary return code */
    AP_UINT32      secondary_rc;          /* secondary return code */
    unsigned char  data_lost;             /* previous indication lost */
    unsigned char  pu_name[8];            /* PU Name */
    unsigned char  description[32];       /* resource description */
    unsigned char  reserv3[16];           /* reserved */
    unsigned char  pu_sscp_sess_active;   /* Is SSCP session active? */
    unsigned char  host_attachment;       /* Host attachment */
    unsigned char  reserv1[2];            /* reserved */
    SESSION_STATS  pu_sscp_stats;         /* PU-SSCP session statistics */
    unsigned char  sscp_id[6];            /* SSCP id */
} PU_INDICATION;
```

```
typedef struct session_stats
{
    AP_UINT16      rcv_ru_size;            /* session receive RU size */
    AP_UINT16      send_ru_size;           /* session send RU size */
    AP_UINT16      max_send_btu_size;      /* maximum send BTU size */
    AP_UINT16      max_rcv_btu_size;       /* maximum rcv BTU size */
    AP_UINT16      max_send_pac_win;       /* maximum send pacing window size */
    AP_UINT16      cur_send_pac_win;       /* current send pacing window size */
    AP_UINT16      max_rcv_pac_win;        /* maximum receive pacing
    /* window size */
    AP_UINT16      cur_rcv_pac_win;        /* current receive pacing
    /* window size */
    AP_UINT32      send_data_frames;       /* number of data frames sent */
    AP_UINT32      send_fmd_data_frames;   /* num fmd data frames sent */
    AP_UINT32      send_data_bytes;        /* number of data bytes sent */
    AP_UINT32      rcv_data_frames;        /* number of data frames received */
    AP_UINT32      rcv_fmd_data_frames;    /* num fmd data frames received */
    AP_UINT32      rcv_data_bytes;         /* number of data bytes received */
    unsigned char  sidh;                   /* session ID high byte
    /* (from LFSID) */
    unsigned char  sidl;                   /* session ID low byte (from LFSID) */
    unsigned char  odai;                   /* ODAI bit set */
    unsigned char  ls_name[8];             /* Link station name */
    unsigned char  reserve;                /* reserved */
} SESSION_STATS;
```

### Parameters

**opcode**

AP\_PU\_INDICATION

**primary\_rc**

AP\_OK

## PU\_INDICATION

### ***data\_lost***

Specifies whether any previous PU indications have been lost. If CS/AIX detects a condition that prevents it from sending an indication (for example an internal resource shortage), it indicates this by setting the *data\_lost* parameter on the next indication after the condition has cleared. Possible values are:

#### **AP\_YES**

One or more previous PU indications were lost. Later fields in this VCB may be set to zeros.

#### **AP\_NO**

No previous PU indications were lost.

### ***pu\_name***

Name of the PU (specified on the DEFINE\_LS verb). This is an 8-byte type-A EBCDIC string, padded on the right with spaces if the name is shorter than 8 characters.

### ***description***

A null-terminated text string describing the PU, as specified in the definition of the PU.

### ***pu\_sscp\_sess\_active***

Specifies whether the PU-SSCP session is active (whether the ACTPU has been successfully processed). Possible values are:

#### **AP\_YES**

The PU-SSCP session is active.

#### **AP\_NO**

The PU-SSCP session is inactive.

### ***host\_attachment***

Local PU host attachment type.

Possible values are:

#### **AP\_DIRECT\_ATTACHED**

PU is directly attached to the host system.

#### **AP\_DLUR\_ATTACHED**

PU is supported by DLUR.

### ***sscp\_id***

For dependent LU sessions, this parameter is the SSCP ID received in the ACTPU from the host for the PU to which the local LU is mapped. For independent LU sessions, this parameter is set to 0 (zero). This value is an array of six bytes displayed as hexadecimal values.

The following parameters are used only when the session state changes from active to inactive:

### ***pu\_sscp\_stats.rcv\_ru\_size***

Reserved (always set to zero).

### ***pu\_sscp\_stats.send\_ru\_size***

Reserved (always set to zero).

### ***pu\_sscp\_stats.max\_send\_btu\_size***

Maximum BTU size that can be sent.

### ***pu\_sscp\_stats.max\_rcv\_btu\_size***

Maximum BTU size that can be received.

### ***pu\_sscp\_stats.max\_send\_pac\_win***

Reserved (always set to zero).

### ***pu\_sscp\_stats.cur\_send\_pac\_win***

Reserved (always set to zero).

### ***pu\_sscp\_stats.max\_rcv\_pac\_win***

Reserved (always set to zero).

### ***pu\_sscp\_stats.cur\_rcv\_pac\_win***

Reserved (always set to zero).



***pu\_sscp\_stats.send\_data\_frames***

Number of normal flow data frames sent.

***pu\_sscp\_stats.send\_fmd\_data\_frames***

Number of normal flow FMD data frames sent.

***pu\_sscp\_stats.send\_data\_bytes***

Number of normal flow data bytes sent.

***pu\_sscp\_stats.rcv\_data\_frames***

Number of normal flow data frames received.

***pu\_sscp\_stats.rcv\_fmd\_data\_frames***

Number of normal flow FMD data frames received.

***pu\_sscp\_stats.rcv\_data\_bytes***

Number of normal flow data bytes received.

***pu\_sscp\_stats.sidh***

Session ID high byte.

***pu\_sscp\_stats.sidl***

Session ID low byte.

***pu\_sscp\_stats.odai***

Origin Destination Assignor Indicator. When bringing up a session, the sender of the BIND sets this field to zero if the local node contains the primary link station and sets it to one if the BIND sender is the node containing the secondary link station.

***pu\_sscp\_stats.ls\_name***

Link station name associated with statistics. This is an 8-byte ASCII character string, right-padded with spaces if the name is shorter than 8 characters.

## RAPI\_CLIENT\_INDICATION

This indication is generated when a Remote API Client connects to or disconnects from a CS/AIX server. A NOF application can use these indications to keep track of which clients are currently using the server as their controller server.

### VCB structure

```
typedef struct rapi_client_indication
{
    AP_UINT16      opcode;                /* verb operation code          */
    unsigned char  reserv2;               /* reserved                      */
    unsigned char  format;                /* reserved                      */
    AP_UINT16      primary_rc;            /* primary return code          */
    AP_UINT32      secondary_rc;          /* secondary return code        */
    unsigned char  data_lost;             /* previous indication lost     */
    unsigned char  reason;                /* reason for indication        */
    unsigned char  sys_name[128];         /* system name client sends us  */
    SNA_IP_ADDR    rapi_client_origin_ip_addr; /* IP addr client sends us    */
    SNA_IP_ADDR    rapi_client_adj_ip_addr; /* IP addr client comes in on  */
    AP_UINT16      rapi_client_adj_port;  /* port IP client comes in on  */
    unsigned char  reserva[16];           /* reserved                      */
} RAPI_CLIENT_INDICATION;

typedef struct sna_ip_addr
{
    AP_UINT16      family;                 /* IPv4 or IPv6                */
    union
    {
        unsigned char  ipv4_addr[4];
        unsigned char  ipv6_addr[16];
    } ip_addr;
} SNA_IP_ADDR;
```

## Parameters

***opcode***

AP\_RAPI\_CLIENT\_INDICATION

***primary\_rc***

AP\_OK

***data\_lost***

Specifies whether any previous client indications have been lost. If CS/AIX detects a condition that prevents it from sending an indication (for example an internal resource shortage), it indicates this by setting the *data\_lost* parameter on the next indication after the condition has cleared. Possible values are:

**AP\_YES**

One or more previous client indications were lost. Later fields in this VCB may be set to zeros.

**AP\_NO**

No previous client indications were lost.

***reason***

Specifies the status change that has occurred for this client. Possible values are:

**AP\_RAPI\_CLIENT\_CONNECTED**

The client has started and has connected to this CS/AIX server as its controller server.

**AP\_RAPI\_CLIENT\_DISCONNECTED**

The client has stopped and has disconnected from the CS/AIX server.

***sys\_name***

The fully-qualified system name of the client (such as `newbox.this.co.uk`).

***rapi\_client\_origin\_ip\_addr***

The IP address of the client.

***rapi\_client\_origin\_ip\_addr.family***

The type of TCP/IP address specified for the client. Possible values are as follows. (These are standard TCP/IP values rather than AP\_\* values defined by CS/AIX.)

**AF\_INET**

IPv4 address, specified as a dotted-decimal address (such as `193.1.11.100`).

**AF\_INET6**

IPv6 address, specified as a colon-hexadecimal address (such as `2001:0db8:0000:0000:0000:0000:1428:57ab` or `2001:db8::1428:57ab`).

**Note:** The values AF\_INET and AF\_INET6 are taken from a system header file, and are not standard AP\_\* values defined by CS/AIX. The system header file is `/usr/include/sys/socket.h` on an AIX server or client, and `/usr/include/linux/socket.h` on a Linux client.

If your NOF application needs to test against these values, you should use `#include` to include this system file in addition to the `nof_c.h` header file.

***rapi\_client\_origin\_ip\_addr.ip\_addr.ipv4\_addr***

This field is used only if the *family* parameter is set to AF\_INET. The IPv4 (dotted-decimal) address of the client computer.

***rapi\_client\_origin\_ip\_addr.ip\_addr.ipv6\_addr***

This field is used only if the *family* parameter is set to AF\_INET6. The IPv6 (colon-hexadecimal) address of the client computer.

***rapi\_client\_adj\_ip\_addr***

The IP address through which the client attaches to CS/AIX. This may not be the same as *rapi\_client\_origin\_ip\_addr* if one of the following is true.

- The client connects through a Web server.
- The client connects through a TCP/IP proxy or NAT router, such as the Linux iptables tool.
- The client has multiple IP addresses.

***rapi\_client\_adj\_ip\_addr.family***

The type of TCP/IP address through which the client attaches to CS/AIX. Possible values are as follows. (These are standard TCP/IP values rather than AP\_\* values defined by CS/AIX.)

**AF\_INET**

IPv4 address, specified as a dotted-decimal address (such as 193.1.11.100).

**AF\_INET6**

IPv6 address, specified as a colon-hexadecimal address (such as 2001:0db8:0000:0000:0000:0000:1428:57ab or 2001:db8::1428:57ab).

**Note:** The values AF\_INET and AF\_INET6 are taken from a system header file, and are not standard AP\_\* values defined by CS/AIX. The system header file is /usr/include/sys/socket.h on an AIX server or client, and /usr/include/linux/socket.h on a Linux client.

If your NOF application needs to test against these values, you should use #include to include this system file in addition to the nof\_c.h header file.

***rapi\_client\_adj\_ip\_addr.ip\_addr.ipv4\_addr***

This field is used only if the *family* parameter is set to AF\_INET. The IPv4 (dotted-decimal) address through which the client attaches to CS/AIX.

***rapi\_client\_adj\_ip\_addr.ip\_addr.ipv6\_addr***

This field is used only if the *family* parameter is set to AF\_INET6. The IPv6 (colon-hexadecimal) address through which the client attaches to CS/AIX.

***rapi\_client\_adj\_port***

The IP port number through which the client attaches to CS/AIX.

## REGISTRATION\_FAILURE

---

REGISTRATION\_FAILURE indicates that an attempt to register resources with the network node server failed.

### VCB structure

```
typedef struct registration_failure
{
    AP_UINT16      opcode;                /* verb operation code          */
    unsigned char  reserv2;              /* reserved                      */
    unsigned char  format;              /* reserved                      */
    AP_UINT16      primary_rc;          /* primary return code          */
    AP_UINT32      secondary_rc;        /* secondary return code        */
    unsigned char  data_lost;           /* previous indication lost      */
    unsigned char  resource_name[17];   /* network qualified resource name */
    AP_UINT16      resource_type;       /* resource type                */
    unsigned char  description[32];     /* resource description          */
    unsigned char  reserv1[16];         /* reserved                      */
    unsigned char  reserv2b[2];         /* reserved                      */
    AP_UINT32      sense_data;          /* sense data                    */
    unsigned char  reserva[20];         /* reserved                      */
} REGISTRATION_FAILURE;
```

### Parameters

***opcode***

AP\_REGISTRATION\_FAILURE

***primary\_rc***

AP\_OK

***data\_lost***

Specifies whether any previous registration failure indications have been lost. If CS/AIX detects a condition that prevents it from sending an indication (for example an internal resource shortage), it indicates this by setting the *data\_lost* parameter on the next indication after the condition has cleared. Possible values are:

## RTP\_INDICATION

### AP\_YES

One or more previous registration failure indications were lost. Later fields in this VCB may be set to zeros.

### AP\_NO

No previous registration failure indications were lost.

### resource\_name

Name of resource that failed to register. The name is a 17-byte EBCDIC string, right-padded with EBCDIC spaces. It consists of a network ID of up to 8 A-string characters, an EBCDIC dot (period) character, and a network name of up to 8 A-string characters.

### resource\_type

Resource type of resource that failed to register. One of the following.

#### AP\_NNCP\_RESOURCE

Network node.

#### AP\_ENCP\_RESOURCE

End node.

#### AP\_LU\_RESOURCE

LU.

### description

A null-terminated text string describing the resource, as specified in the definition of the resource.

### sense\_data

Sense data (specified in SNA Formats).

## RTP\_INDICATION

---

This indication is generated when one of the following occurs:

- An RTP connection is connected or disconnected.
- The active session count changes.
- The connection performs a path-switch.

When the connection is disconnected, final RTP statistics are returned. At other times the *rtp\_stats* parameter is reserved.

## VCB structure

```
typedef struct rtp_indication
{
    AP_UINT16      opcode;                /* Indication operation code      */
    unsigned char  reserv2;               /* reserved                        */
    unsigned char  format;               /* reserved                        */
    AP_UINT16      primary_rc;           /* primary return code            */
    AP_UINT32      secondary_rc;        /* secondary return code          */
    unsigned char  data_lost;           /* Previous indication lost?      */
    unsigned char  connection_state;     /* current state of the RTP      */
                                           /* connection                     */
    unsigned char  rtp_name[8];         /* name of the RTP connection    */
    AP_UINT16      num_sess_active;      /* number of active sessions     */
    unsigned char  indication_cause;    /* reason for this indication     */
    unsigned char  connection_type;     /* usage of RTP connection       */
    unsigned char  reserv3[2];          /* reserved                        */
    RTP_STATISTICS rtp_stats;           /* RTP statistics                 */
} RTP_INDICATION;
```

```
typedef struct rtp_statistics
{
    AP_UINT32      bytes_sent;           /* total number of bytes sent    */
    AP_UINT32      bytes_received;      /* total number of bytes received */
    AP_UINT32      bytes_resent;        /* total number of bytes resent  */
    AP_UINT32      bytes_discarded;     /* total number of bytes discarded */
    AP_UINT32      packets_sent;        /* total number of packets sent  */
    AP_UINT32      packets_received;    /* total number of packets received */
    AP_UINT32      packets_resent      /* total number of packets resent */
}
```

```

AP_UINT32    packets_discarded;    /* total number of packets discarded*/
AP_UINT32    gaps_detected;        /* gaps detected */
AP_UINT32    send_rate;            /* current send rate */
AP_UINT32    max_send_rate;        /* maximum send rate */
AP_UINT32    min_send_rate;        /* minimum send rate */
AP_UINT32    receive_rate;         /* current receive rate */
AP_UINT32    max_receive_rate;     /* maximum receive rate */
AP_UINT32    min_receive_rate;     /* minimum receive rate */
AP_UINT32    burst_size;           /* current burst size */
AP_UINT32    up_time;              /* total uptime of connection */
AP_UINT32    smooth_rtt;           /* smoothed round-trip time */
AP_UINT32    last_rtt;             /* last round-trip time */
AP_UINT32    short_req_timer;      /* SHORT_REQ timer duration */
AP_UINT32    short_req_timeouts;  /* number of SHORT_REQ timeouts */
AP_UINT32    liveness_timeouts;   /* number of liveness timeouts */
AP_UINT32    in_invalid_sna_frames; /* number of invalid SNA frames */
AP_UINT32    /* received */
AP_UINT32    in_sc_frames;         /* number of SC frames received */
AP_UINT32    out_sc_frames;        /* number of SC frames sent */
AP_UINT32    delay_change_sum;     /* delay change sum */
AP_UINT32    current_receiver_threshold; /* current ARB-R receiver threshold */
AP_UINT32    minimum_receiver_threshold; /* minimum ARB-R receiver threshold */
AP_UINT32    maximum_receiver_threshold; /* maximum ARB-R receiver threshold */
AP_UINT32    sent_normals_count;   /* number of NORMALS sent */
AP_UINT32    sent_slowdowns_count; /* number of SLOWDOWNS sent */
AP_UINT32    rcvd_normals_count;   /* number of NORMALS received */
AP_UINT32    rcvd_slowdowns_count; /* number of SLOWDOWNS received */
AP_UINT32    dcs_reset_count_non_heal; /* number of non-healing resets */
AP_UINT16    dcs_reset_count_healing; /* number of self-healing resets */
unsigned char arb_mode;            /* ARB mode (GREEN, YELLOW, RED) */
unsigned char reserve[1];          /* reserved */
} RTP_STATISTICS;

```

## Parameters

### *opcode*

AP\_RTP\_INDICATION

### *primary\_rc*

AP\_OK

### *data\_lost*

Specifies whether any previous directory indications have been lost. If CS/AIX detects a condition that prevents it from sending an indication (for example an internal resource shortage), it indicates this by setting the *data\_lost* parameter on the next indication after the condition has cleared. Possible values are:

#### **AP\_YES**

One or more previous directory indications were lost. Later fields in this VCB may be set to zeros.

#### **AP\_NO**

No previous directory indications were lost.

### *connection\_state*

The current state of the RTP connection. Possible values are:

#### **AP\_CONNECTING**

Connection setup has started but is not yet complete.

#### **AP\_CONNECTED**

The connection is fully active.

#### **AP\_DISCONNECTED**

The connection is no longer active.

### *rtp\_name*

RTP connection name. This name is an 8-byte string in a locally displayable character set. All eight bytes are significant.

## RTP\_INDICATION

### ***num\_sess\_active***

Number of sessions currently active on the connection.

### ***indication\_cause***

Cause of the indication. Possible values are:

#### **AP\_ACTIVATED**

The connection has become active.

#### **AP\_DEACTIVATED**

The connection has become inactive.

#### **AP\_PATH\_SWITCHED**

The connection has successfully completed a path switch.

#### **AP\_SESS\_COUNT\_CHANGING**

The number of active sessions using the connection has changed.

#### **AP\_SETUP\_FAILED**

The connection has failed before becoming fully active.

### ***connection\_type***

Specifies the type of sessions on the RTP connection. Possible values are:

#### **AP\_RTP\_CP\_CP\_SESSION**

The RTP connection carries CP-CP sessions.

#### **AP\_RTP\_LU\_LU\_SESSION**

The RTP connection carries LU-LU sessions.

#### **AP\_RTP\_ROUTE\_SETUP**

The RTP connection is used for route setup.

The following parameters are supplied only when the connection becomes inactive (when the *indication\_cause* parameter is set to AP\_DEACTIVATED or AP\_SETUP\_FAILED). In all other cases, the following parameters are reserved.

### ***rtp\_stats.bytes\_sent***

Total number of bytes that the local node has sent on this RTP connection.

### ***rtp\_stats.bytes\_received***

Total number of bytes that the local node has received on this RTP connection.

### ***rtp\_stats.bytes\_resent***

Total number of bytes that the local node has resent on this RTP connection because of loss in transit.

### ***rtp\_stats.bytes\_discarded***

Total number of bytes sent by the other end of the RTP connection that were discarded as duplicates of data already received.

### ***rtp\_stats.packets\_sent***

Total number of packets that the local node has sent on this RTP connection.

### ***rtp\_stats.packets\_received***

Total number of packets that the local node has received on this RTP connection.

### ***rtp\_stats.packets\_resent***

Total number of packets that the local node has resent on this RTP connection because of loss in transit.

### ***rtp\_stats.packets\_discarded***

Total number of packets sent by the other end of the RTP connection that were discarded as duplicates of data already received.

### ***rtp\_stats.gaps\_detected***

Total number of gaps detected by the local node. Each gap corresponds to one or more lost frames.

### ***rtp\_stats.send\_rate***

Current send rate on this RTP connection, measured in kilobits per second. This is the maximum allowed send rate as calculated by the ARB algorithm.

***rtp\_stats.max\_send\_rate***

Maximum send rate on this RTP connection, measured in kilobits per second.

***rtp\_stats.min\_send\_rate***

Minimum send rate on this RTP connection, measured in kilobits per second.

***rtp\_stats.receive\_rate***

Current receive rate on this RTP connection, measured in kilobits per second. This is the actual receive rate calculated over the last measurement interval.

***rtp\_stats.max\_receive\_rate***

Maximum receive rate on this RTP connection, measured in kilobits per second.

***rtp\_stats.min\_receive\_rate***

Minimum receive rate on this RTP connection, measured in kilobits per second.

***rtp\_stats.burst\_size***

Current burst size on the RTP connection, measured in bytes.

***rtp\_stats.up\_time***

Total number of seconds the RTP connection has been active.

***rtp\_stats.smooth\_rtt***

Smoothed measure of round-trip time between the local node and the partner RTP node, measured in milliseconds.

***rtp\_stats.last\_rtt***

The last measured round-trip time between the local node and the partner RTP node, measured in milliseconds.

***rtp\_stats.short\_req\_timer***

The current duration used for the SHORT\_REQ timer, measured in milliseconds.

***rtp\_stats.short\_req\_timeouts***

Number of SHORT\_REQ timeouts.

***rtp\_stats.liveness\_timeouts***

Total number of times the liveness timer has expired for this RTP connection. The liveness timer expires when the connection has been idle for the specified in the *rtp\_connection\_detail.liveness\_timer*.

***rtp\_stats.in\_invalid\_sna\_frames***

Total number of SNA frames received and discarded as not valid on this RTP connection.

***rtp\_stats.in\_sc\_frames***

Total number of session control frames received on this RTP connection.

***rtp\_stats.out\_sc\_frames***

Total number of session control frames sent on this RTP connection.

***rtp\_stats.delay\_change\_sum***

Value of the delay change sum currently held by the ARB-R algorithm on this RTP connection.

***rtp\_stats.current\_receiver\_threshold***

Value of the receiver threshold currently held by the ARB-R algorithm on this RTP connection.

***rtp\_stats.minimum\_receiver\_threshold***

Value of the minimum receiver threshold currently held by the ARB-R algorithm on this RTP connection.

***rtp\_stats.maximum\_receiver\_threshold***

Value of the maximum receiver threshold currently held by the ARB-R algorithm on this RTP connection.

***rtp\_stats.sent\_normals\_count***

Number of NORMAL feedback ARB-R segments sent by the ARB-R algorithm on this RTP connection.

***rtp\_stats.sent\_slowdowns\_count***

Number of SLOWDOWN1 and SLOWDOWN2 feedback ARB-R segments sent by the ARB-R algorithm on this RTP connection.

## SERVER\_INDICATION

### ***rtp\_stats.rcvd\_normals\_count***

Number of NORMAL feedback ARB-R segments received by the ARB-R algorithm on this RTP connection.

### ***rtp\_stats.rcvd\_slowdowns\_count***

Number of SLOWDOWN1 and SLOWDOWN2 feedback ARB-R segments received by the ARB-R algorithm on this RTP connection.

### ***rtp\_stats.dcs\_reset\_count\_non\_heal***

Number of delay change sum resets made as a part of normal ARB-R processing on this RTP connection.

### ***rtp\_stats.dcs\_reset\_count\_healing***

Number of delay change sum resets made to self-heal the ARB-R algorithm on this RTP connection.

### ***rtp\_stats.arb\_mode***

The current ARB-R status mode on this RTP connection. Possible values are:

- 0** GREEN
- 1** YELLOW
- 2** RED

## SERVER\_INDICATION

---

This indication is generated when the CS/AIX software is started or stopped on another computer on the LAN or when a server's role as controller or backup server changes. A NOF application can use these indications to keep track of which servers are currently active or to determine when a new server has successfully taken over as controller.

Server indications are also generated (for CS/AIX internal use) when the status of other CS/AIX components on a server changes. If the application needs to use server indications as described above, it should check the *status* and *flags* parameters for changes; it can ignore any server indications where these parameters do not indicate a change.

The REGISTER\_INDICATION\_SINK verb used to register for server indications should be issued with a null target handle; it is not associated with any particular target.

## VCB structure

```
typedef struct server_indication
{
    AP_UINT16      opcode;           /* verb operation code          */
    unsigned char  reserv2;         /* reserved                     */
    unsigned char  format;         /* reserved                     */
    AP_UINT16      primary_rc;      /* primary return code          */
    AP_UINT32      secondary_rc;    /* secondary return code        */
    unsigned char  data_lost;       /* previous indication lost     */
    AP_UINT32      status;          /* node status                  */
    AP_UINT32      flags;           /* is server controller or backup? */
    unsigned char  server_name[128]; /* name of server               */
} SERVER_INDICATION;
```

## Parameters

### ***opcode***

AP\_SERVER\_INDICATION

### ***primary\_rc***

AP\_OK



**data\_lost**

Specifies whether any previous server indications have been lost. If CS/AIX detects a condition that prevents it from sending an indication (for example an internal resource shortage), it indicates this by setting the *data\_lost* parameter on the next indication after the condition has cleared. Possible values are:

**AP\_YES**

One or more previous server indications were lost. Later fields in this VCB may be set to zeros.

**AP\_NO**

No previous server indications were lost.

**status**

Specifies the status of the SNA software on the indicated server. Possible values are:

**AP\_ACTIVE**

The SNA software has been started.

**AP\_NOT\_ACTIVE**

The SNA software has been stopped.

**flags**

Specifies whether the indicated server is the controller server or a backup server. The application should use a logical AND operation to check the appropriate values, as follows:

- If the expression "*flags* AND AP\_CONTROLLER\_FLAG" is nonzero, the indicated server is the controller server.
- If the expression "*flags* AND AP\_BACKUP\_FLAG" is nonzero, the indicated server is a backup server.

**server\_name**

Name of the server on which the SNA software has been started or stopped.

## SESSION\_INDICATION

---

This indication is generated when a session is activated or deactivated. When a session is deactivated, the verb returns statistics on the usage of the session.

### VCB structure

```
typedef struct session_indication
{
    AP_UINT16      opcode;           /* verb operation code          */
    unsigned char  reserv2;         /* reserved                     */
    unsigned char  format;         /* reserved                     */
    AP_UINT16      primary_rc;     /* primary return code         */
    AP_UINT32      secondary_rc;   /* secondary return code       */
    unsigned char  data_lost;     /* previous indication lost    */
    unsigned char  deactivated;    /* has session been deactivated? */
    unsigned char  lu_name[8];    /* LU name                     */
    unsigned char  lu_alias[8];   /* LU alias                    */
    unsigned char  plu_alias[8];  /* partner LU alias           */
    unsigned char  fqplu_name[17]; /* fully qualified partner LU name */
    unsigned char  mode_name[8];  /* mode name                  */
    unsigned char  session_id[8]; /* session ID                 */
    FQPCID        fqpcid;        /* fully qualified procedure   */
                                /* correlator ID              */
    AP_UINT32      sense_data;     /* sense data                  */
    unsigned char  reserv1;       /* reserved                    */
    SESSION_STATS  sess_stats;    /* session statistics         */
    unsigned char  sscp_id[6];    /* SSCP ID                    */
    unsigned char  plu_slu_comp_lvl; /* compression level PLU->SLU */
    unsigned char  slu_plu_comp_lvl; /* compression level SLU->PLU */
    unsigned char  comp_in_series; /* reserved                   */
    unsigned char  reserva[11];   /* reserved                    */
} SESSION_INDICATION;
```

```
typedef struct fqpcid
{
    unsigned char  pcid[8];        /* procedure correlator identifier */
    unsigned char  fqcp_name[17]; /* originator's network qualified */
}
```

## SESSION\_INDICATION

```
    unsigned char    reserve3[3];    /* CP name */
} FQPCID;           /* reserved */

typedef struct session_stats
{
    AP_UINT16        rcv_ru_size;    /* session receive RU size */
    AP_UINT16        send_ru_size;   /* session send RU size */
    AP_UINT16        max_send_btu_size; /* maximum send BTU size */
    AP_UINT16        max_rcv_btu_size; /* maximum rcv BTU size */
    AP_UINT16        max_send_pac_win; /* maximum send pacing window size */
    AP_UINT16        cur_send_pac_win; /* current send pacing window size */
    AP_UINT16        max_rcv_pac_win; /* maximum receive pacing window
    /* size */
    AP_UINT16        cur_rcv_pac_win; /* current receive pacing window
    /* size */
    AP_UINT32        send_data_frames; /* number of data frames sent */
    AP_UINT32        send_fmd_data_frames; /* num fmd data frames sent */
    AP_UINT32        send_data_bytes; /* number of data bytes sent */
    AP_UINT32        rcv_data_frames; /* number of data frames received */
    AP_UINT32        rcv_fmd_data_frames; /* num fmd data frames received */
    AP_UINT32        rcv_data_bytes; /* number of data bytes received */
    unsigned char    sidh;           /* session ID high byte
    /* (from LFSID) */
    unsigned char    sidl;           /* session ID low byte (from LFSID) */
    unsigned char    odai;           /* ODAI bit set */
    unsigned char    ls_name[8];     /* Link station name */
    unsigned char    pacing_type;    /* Pacing type */
} SESSION_STATS;
```

## Parameters

### *opcode*

AP\_SESSION\_INDICATION

### *primary\_rc*

AP\_OK

### *data\_lost*

Specifies whether any previous session indications have been lost. If CS/AIX detects a condition that prevents it from sending an indication (for example an internal resource shortage), it indicates this by setting the *data\_lost* parameter on the next indication after the condition has cleared. Possible values are:

#### **AP\_YES**

One or more previous session indications were lost. Later fields in this VCB may be set to zeros.

#### **AP\_NO**

No previous session indications were lost.

### *deactivated*

Specifies whether the session has been deactivated or activated. Possible values are:

#### **AP\_YES**

The session has been deactivated.

#### **AP\_NO**

The session has been activated.

### *lu\_name*

LU name of the local LU, as defined to CS/AIX. This is an 8-byte type-A EBCDIC string, padded on the right with spaces if the name is shorter than 8 bytes.

### *lu\_alias*

LU alias of the local LU, as defined to CS/AIX. This is an 8-byte ASCII string, using any locally displayable characters, padded on the right with spaces if the name is shorter than 8 bytes.

### *plu\_alias*

LU alias of the partner LU. This is an 8-byte ASCII string, using any locally displayable characters, padded on the right with spaces if the name is shorter than 8 bytes.

***fqplu\_name***

Fully qualified LU name for the partner LU, as defined to CS/AIX. This name is a 17-byte EBCDIC string, padded on the right with EBCDIC spaces. It consists of a network ID of 1-8 A-string characters, an EBCDIC dot (period) character, and an LU name of 1-8 A-string characters.

***mode\_name***

Name of the mode used by the LUs. This is an 8-byte alphanumeric type-A EBCDIC string (starting with a letter), padded on the right with EBCDIC spaces if the name is shorter than 8 bytes.

***session\_id***

8-byte identifier of the session.

***fqpcid.pcid***

Procedure Correlator ID. This is an 8-byte hexadecimal string.

***fqpcid.fqcp\_name***

Fully qualified CP name. The name is a 17-byte EBCDIC string, padded on the right with EBCDIC spaces. It consists of a network ID of up to 8 A-string characters, an EBCDIC dot (period) character, and a network name of up to 8 A-string characters.

The following parameters are used only if *deactivated* is set to AP\_YES:

***sense\_data***

The sense data sent or received on the UNBIND message that ended the session.

***duplex\_support***

The conversation duplex support as negotiated on the BIND. Possible values are:

**AP\_HALF\_DUPLEX**

Only half-duplex conversations are supported.

**AP\_FULL\_DUPLEX**

Both half-duplex and full-duplex conversations are supported. Expedited data is also supported.

**AP\_UNKNOWN**

Duplex support is not known because the session has deactivated.

***sess\_stats.rcv\_ru\_size***

Maximum receive RU size.

***sess\_stats.send\_ru\_size***

Maximum send RU size.

***sess\_stats.max\_send\_btu\_size***

Maximum BTU size that can be sent.

***sess\_stats.max\_rcv\_btu\_size***

Maximum BTU size that can be received.

***sess\_stats.max\_send\_pac\_win***

Maximum size of the send pacing window on this session.

***sess\_stats.cur\_send\_pac\_win***

Current size of the send pacing window on this session.

***sess\_stats.max\_rcv\_pac\_win***

Maximum size of the receive pacing window on this session.

***sess\_stats.cur\_rcv\_pac\_win***

Current size of the receive pacing window on this session.

***sess\_stats.send\_data\_frames***

Number of normal flow data frames sent.

***sess\_stats.send\_fmd\_data\_frames***

Number of normal flow FMD data frames sent.

***sess\_stats.send\_data\_bytes***

Number of normal flow data bytes sent.

***sess\_stats.rcv\_data\_frames***

Number of normal flow data frames received.

## SNA\_NET\_INDICATION

### ***sess\_stats.rcv\_fmd\_data\_frames***

Number of normal flow FMD data frames received.

### ***sess\_stats.rcv\_data\_bytes***

Number of normal flow data bytes received.

### ***sess\_stats.sidh***

Session ID high byte.

### ***sess\_stats.sidl***

Session ID low byte.

### ***sess\_stats.odai***

Origin Destination Assignor Indicator. When bringing up a session, the sender of the BIND sets this field to zero if the local node contains the primary link station, and sets it to one if the BIND sender is the node containing the secondary link station.

### ***sess\_stats.ls\_name***

Link station name associated with statistics. This is an 8-byte string in a locally displayable character set. All 8 bytes are significant. This field can be used to correlate the session statistics with the link over which session traffic flows.

### ***sess\_stats.pacing\_type***

The type of receive pacing in use on this session.

### ***sscp\_id***

For dependent LU sessions, the identifier of the SSCP as received in the ACTPU for the PU used by this LU. This parameter is 6 bytes and is used only by dependent LUs. This parameter is set to all zeros for independent LUs.

### ***session\_detail.plu\_slu\_comp\_lvl***

Specifies the compression level for data sent from the primary LU (PLU) to the secondary LU (SLU). Possible values are:

#### **AP\_NONE**

Compression is not used.

#### **AP\_RLE\_COMPRESSION**

Run-length encoding (RLE) compression is used.

#### **AP\_LZ9\_COMPRESSION**

LZ9 compression is used.

#### **AP\_LZ10\_COMPRESSION**

LZ10 compression is used.

### ***session\_detail.slu\_plu\_comp\_lvl***

Specifies the compression level for data sent from the secondary LU (SLU) to the primary LU (PLU). Possible values are:

#### **AP\_NONE**

Compression is not used.

#### **AP\_RLE\_COMPRESSION**

Run-length encoding (RLE) compression is used.

#### **AP\_LZ9\_COMPRESSION**

LZ9 compression is used.

#### **AP\_LZ10\_COMPRESSION**

LZ10 compression is used.

## SNA\_NET\_INDICATION

---

This indication is generated when another NOF application or a CS/AIX administration tool makes a change to the SNA network file `sna.net`. The target for this verb, identified by the *target\_handle* parameter on the REGISTER\_INDICATION\_SINK verb that registers to receive this indication, must be the `sna.net` file.

## VCB structure

No specific VCB structure is associated with this indication. To register for SNA network indications, the application specifies the value `AP_SNA_NET_INDICATION` as the *indication\_opcode* parameter on `REGISTER_INDICATION_SINK`. When a change is made to the SNA network file, CS/AIX then reports this to the application's callback routine by sending a copy of the VCB from the NOF verb (`ADD_BACKUP` or `DELETE_BACKUP`) that made the change.

To enable the application to distinguish between SNA network indications and asynchronous responses to its own NOF verbs issued to the SNA network file, CS/AIX changes the *primary\_rc* parameter in the VCB for an indication. The value `AP_INDICATION` identifies a VCB associated with an SNA network file indication; the value `AP_OK`, or any other value, indicates an asynchronous response to one of the application's own NOF verbs.

## TN\_REDIRECTION\_INDICATION

This indication is generated when a Telnet client starts or ends a session using TN Redirector. It is also generated when the SNA node providing TN Server function is stopped, to notify the application that it will need to re-register for TN Redirection indications; this is because registration for these indications is not maintained when the node stops and restarts.

## VCB structure

```
typedef struct tn_redirection_indication
{
    AP_UINT16      opcode;                /* verb operation code          */
    unsigned char  reserv2;               /* reserved                      */
    unsigned char  format;                /* reserved                      */
    AP_UINT16      primary_rc;            /* primary return code          */
    AP_UINT32      secondary_rc;          /* secondary return code        */
    unsigned char  data_lost;             /* previous indication lost     */
    unsigned char  reason;                /* reason for indication        */
    SNA_IP_ADDR    client_ip_addr;        /* client IP address            */
    AP_UINT16      client_port;           /* client port number           */
    SNA_IP_ADDR    host_ip_addr;          /* host IP address              */
    AP_UINT16      host_port;             /* host port number             */
    unsigned char  client_number;         /* client number                */
    unsigned char  listen_local_address[46];
    unsigned char  reserva[16];           /* reserved                      */
} TN_REDIRECTION_INDICATION;

typedef struct sna_ip_addr
{
    AP_UINT16      family;                /* IPv4 or IPv6                 */
    union
    {
        unsigned char  ipv4_addr[4];
        unsigned char  ipv6_addr[16];
    } ip_addr;
} SNA_IP_ADDR;
```

## Parameters

### **opcode**

`AP_TN_REDIRECTION_INDICATION`

### **primary\_rc**

`AP_OK`

### **data\_lost**

Specifies whether any previous TN redirection indications have been lost. If CS/AIX detects a condition that prevents it from sending an indication (for example an internal resource shortage), it indicates this by setting the *data\_lost* parameter on the next indication after the condition has cleared. Possible values are:

## TN\_REDIRECTION\_INDICATION

### **AP\_YES**

One or more previous TN redirection indications were lost. Later fields in this VCB may be set to zeros.

### **AP\_NO**

No previous TN redirection indications were lost.

### ***reason***

Specifies the reason for sending this indication. Possible values are:

#### **AP\_CONNECTION\_ACTIVATED**

The Telnet client has started a session using TN Redirector.

#### **AP\_CONNECTION\_DEACTIVATED**

The TN Redirector session has ended.

#### **AP\_TN\_SERVER\_TERMINATED**

The node providing TN Server function has stopped. If there were any active TN Redirector sessions using this node, the application will also receive an indication for each session with *reason* set to AP\_CONNECTION\_DEACTIVATED.

If the application needs to continue receiving TN Redirection indications, it should re-register for these indications when the node restarts.

The following fields are not valid if *reason* is set to AP\_TN\_SERVER\_TERMINATED.

### ***client\_ip\_addr.family***

The type of TCP/IP address specified for the computer on which the Telnet client runs. Possible values are as follows. (These are standard TCP/IP values rather than AP\_\* values defined by CS/AIX.)

#### **AF\_INET**

IPv4 address, specified as a dotted-decimal address (such as 193.1.11.100).

#### **AF\_INET6**

IPv6 address, specified as a colon-hexadecimal address (such as 2001:0db8:0000:0000:0000:0000:1428:57ab or 2001:db8::1428:57ab).

**Note:** The values AF\_INET and AF\_INET6 are taken from a system header file, and are not standard AP\_\* values defined by CS/AIX. The system header file is `/usr/include/sys/socket.h` on an AIX server or client, and `/usr/include/linux/socket.h` on a Linux client.

If your NOF application needs to test against these values, you should use `#include` to include this system file in addition to the `nof_c.h` header file.

### ***client\_ip\_addr.ip\_addr.ipv4\_addr***

This field is used only if *client\_ip\_addr.family* is set to AF\_INET. The IPv4 (dotted-decimal) address of the computer on which the Telnet client runs.

### ***client\_ip\_addr.ip\_addr.ipv6\_addr***

This field is used only if *client\_ip\_addr.family* is set to AF\_INET6. The IPv6 (colon-hexadecimal) address of the computer on which the Telnet client runs.

### ***client\_port***

The number of the server TCP/IP port that the Telnet client uses to access the TN Redirector node.

### ***host\_ip\_addr***

The TCP/IP address of the host computer with which the client communicates. This can be either of the following.

- An IPv4 dotted-decimal address (such as 193.1.11.100).
- An IPv6 colon-hexadecimal address (such as 2001:0db8:0000:0000:0000:0000:1428:57ab or 2001:db8::1428:57ab).

### ***host\_port***

The number of the TCP/IP port that the TN Redirector node uses to access the host.

***client\_number***

A number specific to each client. This can be used to correlate successful redirection indications of type AP\_CONNECTION\_ACTIVATED with those of type AP\_CONNECTION\_DEACTIVATED.

***listen\_local\_address***

The address on the local TN Server computer to which TN3270 clients connect.





## Appendix A. Return code values

This appendix lists all the possible return codes in the NOF interface in numerical order. The values are defined in the header file `values_c.h`.

You can use this appendix as a reference to check the meaning of a return code received by your application.

### Primary return codes

The following primary return codes are used in NOF applications.

AP_OK	0x0000
AP_PARAMETER_CHECK	0x0100
AP_STATE_CHECK	0x0200
AP_INDICATION	0x0210
AP_TP_BUSY	0x02F0
AP_ALLOCATION_ERROR	0x0300
AP_ACTIVATION_FAIL_RETRY	0x0310
AP_COMM_SUBSYSTEM_ABENDED	0x03F0
AP_ACTIVATION_FAIL_NO_RETRY	0x0410
AP_COMM_SUBSYSTEM_NOT_LOADED	0x04F0
AP_DEALLOC_ABEND	0x0500
AP_LU_SESS_LIMIT_EXCEEDED	0x0510
AP_DEALLOC_ABEND_PROG	0x0600
AP_FUNCTION_NOT_SUPPORTED	0x0610
AP_THREAD_BLOCKING	0x06F0
AP_DEALLOC_ABEND_SVC	0x0700
AP_DEALLOC_ABEND_TIMER	0x0800
AP_DATA_POSTING_BLOCKED	0x0810
AP_INVALID_VERB_SEGMENT	0x08F0
AP_DEALLOC_NORMAL	0x0900
AP_PATH_SWITCH_NOT_ALLOWED	0x0910
AP_CP_CP_SESS_ACT_FAILURE	0x0A10
AP_PROG_ERROR_NO_TRUNC	0x0C00
AP_PROG_ERROR_TRUNC	0x0D00
AP_PROG_ERROR_PURGING	0x0E00
AP_CONV_FAILURE_RETRY	0x0F00
AP_CONV_FAILURE_NO_RETRY	0x1000
AP_SVC_ERROR_NO_TRUNC	0x1100
AP_UNEXPECTED_DOS_ERROR	0x11F0
AP_SVC_ERROR_TRUNC	0x1200
AP_SVC_ERROR_PURGING	0x1300
AP_UNSUCCESSFUL	0x1400
AP_STACK_TOO_SMALL	0x15F0
AP_MIXED_API_USED	0x16F0
AP_IN_PROGRESS	0x17F0
AP_CNOS_PARTNER_LU_REJECT	0x1800
AP_COMPLETED	0x18F0
AP_CONVERSATION_TYPE_MIXED	0x1900
AP_NODE_STOPPING	0x1A00
AP_NODE_NOT_STARTED	0x1B00
AP_CANCELLED	0x2100
AP_BACKED_OUT	0x2200
AP_DUPLEX_TYPE_MIXED	0x2300
AP_LS_FAILURE	0x2300
AP_OPERATION_INCOMPLETE	0x4000
AP_OPERATION_NOT_ACCEPTED	0x4100
AP_CONVERSATION_ENDED	0x4200
AP_ERROR_INDICATION	0x4300
AP_EXPD_NOT_SUPPORTED_BY_LU	0x4400
AP_BUFFER_TOO_SMALL	0x4500
AP_MEMORY_ALLOCATION_FAILURE	0x4600
AP_INVALID_VERB	0xFFFF

## Secondary return codes

The following secondary return codes are used in NOF applications.

AP_AS_SPECIFIED	0x00000000
AP_ALLOCATION_ERROR_PENDING	0x00000300
AP_DEALLOC_ABEND_PROG_PENDING	0x00000600
AP_DEALLOC_ABEND_SVC_PENDING	0x00000700
AP_DEALLOC_ABEND_TIMER_PENDING	0x00000800
AP_UNKNOWN_ERROR_TYPE_PENDING	0x00001100
AP_BO_NO_RESYNC	0x00002408
AP_TRANS_PGM_NOT_AVAIL_NO_RETRY	0x00004C08
AP_INVALID_SET_PROT	0x00070000
AP_INVALID_DLUS_NAME	0x00900000
AP_SEC_BAD_PASSWORD_EXPIRED	0x00FF0F08
AP_BAD_TP_ID	0x01000000
AP_BO_RESYNC	0x01002408
AP_INVALID_NEW_PROT	0x01070000
AP_DLC_ACTIVE	0x01100000
AP_NO_DEFAULT_DLUS_DEFINED	0x01900000
AP_BAD_TPSID	0x01FF0000
AP_SEC_BAD_PASSWORD_INVALID	0x01FF0F08
AP_BAD_CONV_ID	0x02000000
AP_SEND_ERROR_LOG_LL_WRONG	0x02010000
AP_INVALID_SET_UNPROT	0x02070000
AP_INVALID_NUMBER_OF_NODE_ROWS	0x02080000
AP_DUPLICATE_CP_NAME	0x02100000
AP_INVALID_PU_ID	0x02900000
AP_NOT_OWNER	0x02FF0000
AP_SEC_BAD_USERID_REVOKED	0x02FF0F08
AP_BAD_LU_ALIAS	0x03000000
AP_BAD_DLOAD_ID	0x03000001
AP_BAD_REMOTE_LU_ALIAS	0x03000002
AP_SEND_ERROR_BAD_TYPE	0x03010000
AP_INVALID_NEW_UNPROT	0x03070000
AP_DUPLICATE_DEST_ADDR	0x03100000
AP_PU_ALREADY_ACTIVATING	0x03900000
AP_INSUFFICIENT_PRIVILEGES	0x03FF0000
AP_SEC_BAD_USERID_INVALID	0x03FF0F08
AP_ALLOCATION_FAILURE_NO_RETRY	0x04000000
AP_SEND_ERROR_BAD_STATE	0x04010000
AP_INVALID_SET_USER	0x04070000
AP_NODE_ROW_WGT_LESS_THAN_LAST	0x04080000
AP_CANT_MODIFY_PORT_NAME	0x04100000
AP_PU_ALREADY_DEACTIVATING	0x04900000
AP_INVALID_CALLBACK	0x04FF0000
AP_SEC_BAD_USERID_MISSING	0x04FF0F08
AP_ALLOCATION_FAILURE_RETRY	0x05000000
AP_BAD_ERROR_DIRECTION	0x05010000
AP_INVALID_DATA_TYPE	0x05070000
AP_TG_ROW_WGT_LESS_THAN_LAST	0x05080000
AP_DUPLICATE_PORT_NUMBER	0x05100000
AP_PU_ALREADY_ACTIVE	0x05900000
AP_BAD_TP_TYPE	0x05FF0000
AP_SEC_BAD_PASSWORD_MISSING	0x05FF0F08
AP_INVALID_STATS_TYPE	0x06070000
AP_DUPLICATE_PORT_NAME	0x06100000
AP_PU_NOT_ACTIVE	0x06900000
AP_ALREADY_REGISTERED	0x06FF0000
AP_SEC_BAD_GROUP_INVALID	0x06FF0F08
AP_AS_NEGOTIATED	0x07000000
AP_INVALID_TABLE_TYPE	0x07070000
AP_INVALID_DLC_NAME	0x07100000
AP_DLUS_REJECTED	0x07900000
AP_SEC_BAD_UID_REVOKED_IN_GRP	0x07FF0F08
AP_PORT_DEACTIVATED	0x08070000
AP_INVALID_DLC_TYPE	0x08100000
AP_DLUS_CAPS_MISMATCH	0x08900000
AP_SEC_BAD_UID_NOT_DEFD_TO_GRP	0x08FF0F08
AP_ALLOCATE_NOT_PENDING	0x09050000
AP_INVALID_SET_PASSWORD	0x09070000
AP_INVALID_NUMBER_OF_TG_ROWS	0x09080000
AP_INVALID_LINK_ACTIVE_LIMIT	0x09100000
AP_PU_FAILED_ACTPU	0x09900000
AP_SEC_BAD_UNAUTHRZD_AT_RLU	0x09FF0F08
AP_SNA_DEFD_COS_CANT_BE_CHANGE	0x0A080000
AP_SNA_DEFD_COS_CANT_BE_CHANGED	0x0A080000
AP_PU_NOT_RESET	0x0A900000
AP_SEC_BAD_UNAUTHRZD_FROM_LLU	0x0AFF0F08
AP_INVALID_NUM_PORTS_SPECIFIED	0x0B100000

AP_PU_OWNS_LUS	0x0B900000
AP_SEC_BAD_UNAUTHRD_TO_TP	0x0BFF0F08
AP_INVALID_PORT_NAME	0x0C100000
AP_INVALID_FILTER_OPTION	0x0C900000
AP_SEC_BAD_INSTALL_EXIT_FAILED	0x0CFF0F08
AP_INVALID_PORT_TYPE	0x0D100000
AP_INVALID_STOP_TYPE	0x0D900000
AP_SEC_BAD_PROCESSING_FAILURE	0x0DFF0F08
AP_UNRECOGNIZED_DEACT_TYPE	0x0E050000
AP_PORT_ACTIVE	0x0E100000
AP_PU_ALREADY_DEFINED	0x0E900000
AP_NO_PORTS_DEFINED_ON_DLC	0x0F100000
AP_DEPENDENT_LU_NOT_SUPPORTED	0x0F900000
AP_INVALID_DLC	0x10050000
AP_COS_NAME_NOT_DEFD	0x10080000
AP_DUPLICATE_PORT	0x10100000
AP_INVALID_DSPU_SERVICES	0x10900000
AP_BAD_CONV_TYPE	0x11000000
AP_SNA_DEFD_COS_CANT_BE_DELETE	0x11080000
AP_SNA_DEFD_COS_CANT_BE_DELETED	0x11080000
AP_STOP_PORT_PENDING	0x11100000
AP_DSPU_SERVICES_NOT_SUPPORTED	0x11900000
AP_BAD_SYNC_LEVEL	0x12000000
AP_LU_NAU_ADDR_ALREADY_DEFD	0x12020000
AP_INVALID_SESSION_ID	0x12050000
AP_LINK_DEACT_IN_PROGRESS	0x12100000
AP_INVALID_DSPU_NAME	0x12900000
AP_BAD_SECURITY	0x13000000
AP_INVALID_NN_SESSION_TYPE	0x13050000
AP_LINK_DEACTIVATED	0x13100000
AP_PARTNER_NOT_FOUND	0x13200000
AP_PARTNER_NOT_RESPONDING	0x13300000
AP_ERROR	0x13400000
AP_DSPU_ALREADY_DEFINED	0x13900000
AP_BAD_RETURN_CONTROL	0x14000000
AP_INVALID_MAX_NEGOT_SESS_LIM	0x14020000
AP_INVALID_SET_COLLECT_STATS	0x14050000
AP_LINK_ACT_BY_REMOTE	0x14100000
AP_INVALID_SOLICIT_SSCP_SESS	0x14900000
AP_INVALID_BACK_LEVEL_SUPPORT	0x15000000
AP_INVALID_MODE_NAME	0x15020000
AP_INVALID_SET_COLLECT_NAMES	0x15050000
AP_LINK_ACT_BY_LOCAL	0x15100000
AP_INVALID_TG_NUMBER	0x15500000
AP_MISSING_CP_NAME	0x15510000
AP_MISSING_CP_TYPE	0x15520000
AP_INVALID_CP_TYPE	0x15520000
AP_DUPLICATE_TG_NUMBER	0x15530000
AP_TG_NUMBER_IN_USE	0x15540000
AP_MISSING_TG_NUMBER	0x15550000
AP_PARALLEL_TGS_NOT_ALLOWED	0x15570000
AP_INVALID_BKUP_DLU_NAME	0x15900000
AP_PIP_LEN_INCORRECT	0x16000000
AP_INVALID_RECV_PACING_WINDOW	0x16020000
AP_INVALID_SET_COLLECT_RSCVS	0x16050000
AP_SEC_REQUESTED_NOT_SUPPORTED	0x16900000
AP_NO_USE_OF_SNASVCMG	0x17000000
AP_INVALID_CNOS_SLIM	0x17020000
AP_LINK_NOT_DEFD	0x17100000
AP_INVALID_DUPLEX_SUPPORT	0x17900000
AP_UNKNOWN_PARTNER_MODE	0x18000000
AP_INVALID_TARGET_PACING_CNT	0x18020000
AP_PS_CREATION_FAILURE	0x18100000
AP_QUEUE_PROHIBITED	0x18900000
AP_INVALID_MAX_RU_SIZE_UPPER	0x19020000
AP_TP_ACTIVE	0x19100000
AP_INVALID_TEMPLATE_NAME	0x19900000
AP_INVALID_SNASVCMG_MODE_LIMIT	0x1A020000
AP_MODE_ACTIVE	0x1A100000
AP_CLASHING_NAU_RANGE	0x1A900000
AP_PLU_ACTIVE	0x1B100000
AP_INVALID_NAU_RANGE	0x1B900000
AP_INVALID_COS_SNASVCMG_MODE	0x1C020000
AP_INVALID_PLU_NAME	0x1C100000
AP_INVALID_NUM_DSLU_TEMPLATES	0x1C900000
AP_INVALID_DEFAULT_RU_SIZE	0x1D020000
AP_INVALID_SET_NEGOTIABLE	0x1D100000
AP_GLOBAL_TIMEOUT_NOT_DEFINED	0x1D900000
AP_INVALID_MIN_CONWINNERS	0x1E020000
AP_INVALID_MODE_NAME_SELECT	0x1E100000
AP_INVALID_RESOURCE_NAME	0x1E900000
AP_INVALID_RESPONSIBLE	0x1F100000

## Secondary return codes

AP_INVALID_DLU_RETRY_TIMEOUT	0x1F900000
AP_MODE_SESS_LIM_EXCEEDS_NEG	0x20020000
AP_INVALID_DRAIN_SOURCE	0x20100000
AP_INVALID_DLU_RETRY_LIMIT	0x20900000
AP_CPSVCMG_ALREADY_DEF	0x21020000
AP_INVALID_CN_NAME	0x21080000
AP_INVALID_DRAIN_TARGET	0x21100000
AP_TP_NAME_NOT_RECOGNIZED	0x21600810
AP_INVALID_MIN_CONLOSERS	0x21900000
AP_BAD_DUPLEX_TYPE	0x22000000
AP_INVALID_BYPASS_SECURITY	0x22020000
AP_DEF_LINK_INVALID_SECURITY	0x22080000
AP_INVALID_FORCE	0x22100000
AP_SYSTEM_TP_CANT_BE_CHANGED	0x22600810
AP_INVALID_MAX_RU_SIZE_LOW	0x22900000
AP_FDX_NOT_SUPPORTED_BY_LU	0x23000000
AP_TEST_INVALID_FOR_FDX	0x23010000
AP_INVALID_IMPLICIT_PLU_FORBID	0x23020000
AP_INVALID_PROPAGATION_DELAY	0x23080000
AP_SYSTEM_TP_CANT_BE_DELETED	0x23600810
AP_INVALID_MAX_RECV_PACING_WIN	0x23900000
AP_SEND_EXPD_INVALID_LENGTH	0x24010000
AP_INVALID_SPECIFIC_SECURITY	0x24020000
AP_INVALID_EFFECTIVE_CAPACITY	0x24080000
AP_INVALID_CLEANUP_TYPE	0x24100000
AP_INVALID_DYNAMIC_LOAD	0x24600810
AP_RU_SIZE_LOW_UPPER_MISMATCH	0x24900000
AP_RCV_EXPD_INVALID_LENGTH	0x25010000
AP_INVALID_DELAYED_LOGON	0x25020000
AP_INVALID_COS_NAME	0x25100000
AP_INVALID_ENABLED	0x25600810
AP_LU_ALREADY_ACTIVATING	0x25900000
AP_EXPD_BAD_RETURN_CONTROL	0x26010000
AP_INVALID_CNOS_PERMITTED	0x26020000
AP_PW_SUB_NOT_SUPP_ON_SESS	0x26050000
AP_INVALID_SESSION_LIMIT	0x26100000
AP_INVALID_PIP_ALLOWED	0x26600810
AP_LU_DEACTIVATING	0x26900000
AP_EXPD_DATA_BAD_CONV_STATE	0x27010000
AP_INVALID_DRAIN	0x27100000
AP_LU_ALREADY_ACTIVE	0x27900000
AP_INVALID_PRL_SESS_SUPP	0x28100000
AP_INVALID_MIN_CONTENTION_SUM	0x28900000
AP_INVALID_LU_NAME	0x29100000
AP_COMPRESSION_NOT_SUPPORTED	0x29900000
AP_MODE_NOT_RESET	0x2A100000
AP_INVALID_MAX_COMPRESS_LVL	0x2A900000
AP_MODE_RESET	0x2B100000
AP_INVALID_COMPRESSION	0x2B900000
AP_CNOS_REJECT	0x2C100000
AP_INVALID_EXCEPTION_INDEX	0x2C900000
AP_INVALID_OP_CODE	0x2D100000
AP_INVALID_MAX_LS_EXCEPTION	0x2D900000
AP_INVALID_DISABLE	0x2E900000
AP_INVALID_MODIFY_TEMPLATE	0x2F900000
AP_INVALID_ALLOW_TIMEOUT	0x30900000
AP_CONFIRM_ON_SYNC_LEVEL_NONE	0x31000000
AP_PIP_NOT_ALLOWED	0x31600810
AP_TRANS_PGM_NOT_AVAIL_RETRY	0x31604B08
AP_POST_ON_RECEIPT_BAD_FILL	0x31900000
AP_CONFIRM_BAD_STATE	0x32000000
AP_UNKNOWN_USER	0x32100000
AP_POST_ON_RECEIPT_BAD_STATE	0x32900000
AP_CONFIRM_NOT_LL_BDY	0x33000000
AP_NO_PROFILES	0x33100000
AP_INVALID_HPR_SUPPORT	0x33900000
AP_CONFIRM_INVALID_FOR_FDX	0x34000000
AP_CONVERSATION_TYPE_MISMATCH	0x34600810
AP_INVALID_LU_MODEL	0x34900000
AP_INVALID_MODEL_NAME	0x35900000
AP_TOO_MANY_PROFILES	0x36100000
AP_INVALID_CRYPTOGRAPHY	0x36900000
AP_INVALID_UPDATE_TYPE	0x37100000
AP_INVALID_CLU_CRYPTOGRAPHY	0x37900000
AP_DIR_ENTRY_PARENT	0x38100000
AP_INVALID_RESOURCE_TYPES	0x38900000
AP_NODE_ALREADY_STARTED	0x39100000
AP_CHECKSUM_FAILED	0x39900000
AP_NODE_FAILED_TO_START	0x3A100000
AP_DATA_CORRUPT	0x3A900000
AP_LU_ALREADY_DEFINED	0x3B100000
AP_INVALID_RETRY_FLAGS	0x3B900000

AP_IMPLICIT_LU_DEFINED	0x3C100000
AP_DELAYED_VERB_PENDING	0x3C900000
AP_PORT_INACTIVE	0x3D100000
AP_DSLU_ACTIVE	0x3D900000
AP_ACTIVATION_LIMITS_REACHED	0x3E100000
AP_ACTIVATION_LIMITS_REACHED	0x3E100000
AP_INVALID_BRANCH_LINK_TYPE	0x3E900000
AP_PARALLEL_TGS_NOT_SUPPORTED	0x3F100000
AP_INVALID_BRNN_SUPPORT	0x3F900000
AP_DLC_INACTIVE	0x40100000
AP_BRNN_SUPPORT_MISSING	0x40900000
AP_CONFIRMED_BAD_STATE	0x41000000
AP_NO_LINKS_DEFINED	0x41100000
AP_SYNC_LEVEL_NOT_SUPPORTED	0x41600810
AP_INVALID_UPLINK	0x41900000
AP_CONFIRMED_INVALID_FOR_FDX	0x42000000
AP_STOP_DLC_PENDING	0x42100000
AP_INVALID_DOWNLINK	0x42900000
AP_INVALID_LS_ROLE	0x43100000
AP_INVALID_IMPLICIT_UPLINK	0x43900000
AP_INVALID_BTU_SIZE	0x44100000
AP_INVALID_ROCP_NAME	0x44900000
AP_LAST_LINK_ON_ACTIVE_PORT	0x45100000
AP_INVALID_REG_WITH_NN	0x45900000
AP_DYNAMIC_LOAD_ALREADY_REGD	0x46100000
AP_LS_PENDING_RETRY	0x46900000
AP_INVALID_LIST_OPTION	0x47100000
AP_INVALID_COS_TABLE_VERSION	0x47900000
AP_INVALID_RES_NAME	0x48100000
AP_CFRTP_REQUIRED_FOR_MLTG	0x48900000
AP_INVALID_RES_TYPE	0x49100000
AP_INVALID_MLTG_PAC_ALGORITHM	0x49900000
AP_INVALID_ADJ_NNCP_NAME	0x4A100000
AP_LIM_RESOURCE_INVALID_FOR_MLTG	0x4A900000
AP_INVALID_NODE	0x4B100000
AP_AUTO_ACT_INVALID_FOR_MLTG	0x4B900000
AP_INVALID_ORIGIN_NODE	0x4C100000
AP_MLTG_LS_VISIBILITY_MISMATCH	0x4C900000
AP_INVALID_TG	0x4D100000
AP_SLTG_LINK_ACTIVE	0x4D900000
AP_INVALID_FQPCID	0x4E100000
AP_MLTG_LINK_PROPERTIES_DIFFER	0x4E900000
AP_INVALID_POOL_NAME	0x4F100000
AP_INVALID_ADJ_CP_NAME	0x4F900000
AP_BAD_TYPE	0x50020000
AP_INVALID_NAU_ADDRESS	0x50100000
AP_INVALID_ENABLE_POOL	0x50300000
AP_INVALID_SEND_TERM_SELF	0x50900000
AP_DEALLOC_BAD_TYPE	0x51000000
AP_LU_NAME_POOL_NAME_CLASH	0x51100000
AP_SECURITY_NOT_VALID	0x51600F08
AP_INVALID_TERM_METHOD	0x51900000
AP_DEALLOC_FLUSH_BAD_STATE	0x52000000
AP_INVALID_PRIORITY	0x52100000
AP_INVALID_DISABLE_BRANCH_AWRN	0x52900000
AP_DEALLOC_CONFIRM_BAD_STATE	0x53000000
AP_INVALID_DNST_LU_NAME	0x53100000
AP_INVALID_SHARING_PROHIBITED	0x53900000
AP_INVALID_HOST_LU_NAME	0x54100000
AP_INVALID_LINK_SPEC_FORMAT	0x54900000
AP_DEALLOC_NOT_LL_BDY	0x55000000
AP_PU_NOT_DEFINED	0x55100000
AP_INVALID_CN_TYPE	0x55900000
AP_INVALID_PU_NAME	0x56100000
AP_INVALID_PU_TYPE	0x56600000
AP_INCONSISTENT_BEST_EFFORT	0x56900000
AP_DEALLOC_LOG_LL_WRONG	0x57000000
AP_CNOS_MODE_NAME_REJECT	0x57010000
AP_INVALID_MAX_IFRM_RCVD	0x57100000
AP_INVALID_CN_TG	0x57900000
AP_INVALID_SYM_DEST_NAME	0x58100000
AP_SEC_BAD_PROTOCOL_VIOLATION	0x58600F08
AP_INVALID_LINK_SPEC_DATA	0x58900000
AP_INVALID_LENGTH	0x59100000
AP_DLC_UI_ONLY	0x59900000
AP_INVALID_ISR_THRESHOLDS	0x5A100000
AP_ADJ_CP_WRONG_TYPE	0x5A900000
AP_BAD_PARTNER_LU_ALIAS	0x5B010000
AP_INVALID_NUM_LUS	0x5B100000
AP_CP_CP_SESS_ALREADY_ACTIVE	0x5B900000
AP_EXCEEDS_MAX_ALLOWED	0x5C010000
AP_CANT_DELETE_ADJ_ENDNODE	0x5C100000

## Secondary return codes

AP_NO_ACTIVE_CP_CP_LINK	0x5C900000
AP_LU_MODE_SESSION_LIMIT_ZERO	0x5D010000
AP_INVALID_RESOURCE_TYPE	0x5D100000
AP_PU_CONC_NOT_SUPPORTED	0x5E100000
AP_INVALID_IMPL_APPN_LINKS_LEN	0x5E900000
AP_CNOS_COMMAND_RACE_REJECT	0x5F010000
AP_DLUR_NOT_SUPPORTED	0x5F100000
AP_INVALID_LIMIT_ENABLE	0x5F900000
AP_INVALID_SVCMG_LIMITS	0x60010000
AP_INVALID_RTP_CONNECTION	0x60100000
AP_INVALID_LS_ATTRIBUTE	0x60900000
AP_FLUSH_NOT_SEND_STATE	0x61000000
AP_PATH_SWITCH_IN_PROGRESS	0x61100000
AP_HPR_NOT_SUPPORTED	0x62100000
AP_SOME_ENABLED	0x62900000
AP_RTP_NOT_SUPPORTED	0x63100000
AP_NONE_ENABLED	0x63900000
AP_COS_TABLE_FULL	0x64100000
AP_INCONSISTENT_IMPLICIT	0x64900000
AP_INVALID_DAYS_LEFT	0x65100000
AP_ANYNET_NOT_SUPPORTED	0x66100000
AP_INVALID_PERSIST_PIPE_SUPP	0x66900000
AP_INVALID_DISCOVERY_SUPPORT	0x67100000
AP_ACTIVATION_PROHIBITED	0x67900000
AP_SESSION_FAIL_ALREADY_REGD	0x68100000
AP_INVALID_NULL_ADDR_MEANING	0x68900000
AP_CANT_MODIFY_VISIBILITY	0x69100000
AP_INVALID_CPLU_SYNCPT_SUPPORT	0x69900000
AP_CANT_MODIFY_WHEN_ACTIVE	0x6A100000
AP_INVALID_CPLU_ATTRIBUTES	0x6A900000
AP_INVALID_BASE_NUMBER	0x6B100000
AP_INVALID_REG_LEN_SUPPORT	0x6B900000
AP_DEACT_CG_INVALID_CGID	0x6C020000
AP_INVALID_NAME_ATTRIBUTES	0x6C100000
AP_LUNAME_CGID_MISMATCH	0x6C900000
AP_NAU_ADDRESS_MISMATCH	0x6D100000
AP_INVALID_DDDLU_OFFLINE	0x6D900000
AP_POSTED_DATA	0x6E100000
AP_POSTED_NO_DATA	0x6F100000
AP_DEF_PLU_INVALID_FQ_NAME	0x74020000
AP_DLC_DEACTIVATING	0x86020000
AP_INVALID_WILDCARD_NAME	0x8C020000
AP_DUPLICATE	0x8D020000
AP_LU_NAME_WILDCARD_NAME_CLASH	0x8E020000
AP_INVALID_USERID	0x90020000
AP_INVALID_PASSWORD	0x91020000
AP_INVALID_PROFILE	0x93020000
AP_INVALID_TP_NAME	0xA0020000
AP_P_TO_R_INVALID_TYPE	0xA1000000
AP_INVALID_CONV_TYPE	0xA1020000
AP_P_TO_R_NOT_LL_BDY	0xA2000000
AP_P_TO_R_NOT_SEND_STATE	0xA3000000
AP_INVALID_SYNC_LEVEL	0xA3020000
AP_P_TO_R_INVALID_FOR_FDX	0xA5000000
AP_INVALID_LINK_NAME_SPECIFIED	0xB0020000
AP_RCV_AND_WAIT_BAD_STATE	0xB1000000
AP_INVALID_LU_ALIAS	0xB1020000
AP_RCV_AND_WAIT_NOT_LL_BDY	0xB2000000
AP_INVALID_NUM_LS_SPECIFIED	0xB2020000
AP_PLU_ALIAS_CANT_BE_CHANGED	0xB3020000
AP_PLU_ALIAS_ALREADY_USED	0xB4020000
AP_RCV_AND_WAIT_BAD_FILL	0xB5000000
AP_INVALID_AUTO_ACT_SUPP	0xB5020000
AP_CANT_DELETE_IMPLICIT_LU	0xB6020000
AP_FORCED	0xB7020000
AP_INVALID_LS_NAME	0xB7030000
AP_INVALID_LFSID_SPECIFIED	0xB7040000
AP_INVALID_FILTER_TYPE	0xB7050000
AP_INVALID_MESSAGE_TYPE	0xB7060000
AP_CANT_DELETE_CP_LU	0xB7070000
AP_ALL_RESOURCES_NOT_DEFINED	0xB7090000
AP_INVALID_LIST_TYPE	0xB70A0000
AP_RESOURCE_NAME_NOT_ALLOWED	0xB70B0000
AP_LU_ALIAS_CANT_BE_CHANGED	0xB8020000
AP_LU_ALIAS_ALREADY_USED	0xB9020000
AP_INVALID_LINK_ENABLE	0xBA020000
AP_INVALID_CLU_COMPRESSION	0xBB020000
AP_INVALID_DLUR_SUPPORT	0xBC020000
AP_ALREADY_STARTING	0xC0010000
AP_RCV_IMMD_BAD_STATE	0xC1000000
AP_INVALID_LINK_NAME	0xC1010000
AP_INVALID_USER_DEF_1	0xC3010000

AP_RCV_IMMD_BAD_FILL	0xC4000000
AP_INVALID_USER_DEF_2	0xC4010000
AP_INVALID_NODE_TYPE	0xC4020000
AP_INVALID_USER_DEF_3	0xC5010000
AP_INVALID_NAME_LEN	0xC5020000
AP_INVALID_NETID_LEN	0xC6020000
AP_INVALID_NODE_TYPE_FOR_HPR	0xC8020000
AP_INVALID_MAX_DECOMPRESS_LVL	0xC9020000
AP_INVALID_CP_NAME	0xCA010000
AP_INVALID_COMP_IN_SERIES	0xCA020000
AP_INVALID_LIMITED_RESOURCE	0xCE010000
AP_RCV_AND_POST_BAD_STATE	0xD1000000
AP_INVALID_BYTE_COST	0xD1010000
AP_RCV_AND_POST_NOT_LL_BDY	0xD2000000
AP_RCV_AND_POST_BAD_FILL	0xD5000000
AP_INVALID_TIME_COST	0xD6010000
AP_BAD_RETURN_STATUS_WITH_DATA	0xD7000000
AP_LOCAL_CP_NAME	0xD7010000
AP_LS_ACTIVE	0xDA010000
AP_INVALID_FQ_OWNING_CP_NAME	0xDB020000
AP_R_T_S_BAD_STATE	0xE1000000
AP_R_T_S_INVALID_FOR_FDX	0xE2000000
AP_BAD_LL	0xF1000000
AP_SEND_DATA_NOT_SEND_STATE	0xF2000000
AP_CP_OR_SNA_SVCMG_UNDELETABLE	0xF3010000
AP_SEND_DATA_INVALID_TYPE	0xF4000000
AP_DEL_MODE_DEFAULT_SPCD	0xF4010000
AP_SEND_DATA_CONFIRM_SYNC_NONE	0xF5000000
AP_MODE_NAME_NOT_DEFD	0xF5010000
AP_SEND_DATA_NOT_LL_BDY	0xF6000000
AP_MODE_UNDELETABLE	0xF6010000
AP_SEND_TYPE_INVALID_FOR_FDX	0xF7000000
AP_INVALID_FQ_LU_NAME	0xFD010000
AP_INVALID_PARTNER_LU	0xFE010000
AP_INVALID_LOCAL_LU	0xFF010000





---

## Appendix B. Common return codes

This appendix describes the primary and secondary return codes that are common to all NOF verbs.

Return codes that are specific to a particular verb, or a group of verbs, are described in the individual verb descriptions in [Chapter 3, “NOF API Verbs,”](#) on page 35.

---

### Communications subsystem not active

If the verb does not execute because a required component is not active, CS/AIX returns the following parameters:

***primary\_rc***

AP\_COMM\_SUBSYSTEM\_ABENDED

***secondary\_rc***

One of the following:

**AP\_LOCAL\_ABENDED**

The CS/AIX software has stopped.

**AP\_TARGET\_ABENDED**

The target node has stopped or the communication path to it has failed.

***primary\_rc***

**AP\_COMM\_SUBSYSTEM\_NOT\_LOADED**

The CS/AIX software is not active.

***secondary\_rc***

Not used.

***primary\_rc***

**AP\_NODE\_NOT\_STARTED**

The target node has not been started.

***secondary\_rc***

Not used.

***primary\_rc***

**AP\_NODE\_STOPPING**

The target node is in the process of stopping (as a result of a TERM\_NODE verb).

***secondary\_rc***

Not used.

---

### Indication

This return code does not signify an error.

If the application has registered using REGISTER\_INDICATION\_SINK to receive configuration indications or SNA network file indications, CS/AIX sends an indication each time another NOF API application or a CS/AIX component modifies the target file or the target node's configuration. The format of this indication is the same as the returned VCB for the NOF verb that modified the configuration. CS/AIX sets this primary return code to indicate that the VCB being returned is a configuration indication or an SNA network file indication, rather than the response to a verb issued by the application; this enables the application to distinguish between its own verb returns and indications resulting from verbs issued by other applications.

***primary\_rc***

AP\_INDICATION

## Invalid function

### *secondary\_rc*

Possible values are:

#### **AP\_EXTRA\_DATA\_LOST**

CS/AIX was unable to allocate sufficient storage to return the complete VCB for this indication; the returned information is incomplete. The application should issue the appropriate QUERY\_\* verb to obtain more information about the modified component.

#### **(zero)**

The complete VCB for this indication is being returned.

## Invalid function

---

If the verb does not execute because the node does not recognize it as a valid verb, CS/AIX returns the following parameters:

### *primary\_rc*

#### **AP\_INVALID\_VERB**

The *opcode* parameter was not set to the operation code of any NOF verb, or the verb identified by this parameter cannot be used because this version of CS/AIX does not support it.

### *secondary\_rc*

Not used.

### *primary\_rc*

#### **AP\_FUNCTION\_NOT\_SUPPORTED**

The NOF verb identified by the specified *opcode* parameter cannot be used because the target node's configuration does not support it.

### *secondary\_rc*

Not used.

## Invalid verb segment

---



If the verb does not execute because the VCB was not contained within a data segment, CS/AIX returns the following parameters:

### *primary\_rc*

#### **AP\_INVALID\_VERB\_SEGMENT**

The verb control block extended beyond the end of a data segment. The verb did not execute.

A secondary return code is not returned.



## Parameter check

---

If the verb does not execute because of a parameter error, CS/AIX returns the following parameters:

### *primary\_rc*

AP\_PARAMETER\_CHECK

### *secondary\_rc*

One of the following:

#### **AP\_INVALID\_FORMAT**

The reserved parameter *format* was not set to zero.

#### **AP\_INVALID\_TARGET\_HANDLE**

The supplied target handle is not valid.

**AP\_INVALID\_TARGET**

The verb cannot be issued to the specified target. For example, QUERY\_PARTNER\_LU, which returns information about an LU's current usage, can be issued only to a running node; it is not valid when issued to a file.

**AP\_INVALID\_TARGET\_MODE**

The verb cannot be issued in the current mode. For example, only QUERY\_\* verbs can be issued in read-only mode; DEFINE\_\*, DELETE\_\*, START\_\*, and STOP\_\* verbs are not valid in this mode.

**AP\_NOT\_SERVER**

This return code occurs only when you are running the NOF application program on a client. The verb that you issued is not valid on a client; it can be issued only on a server.

**AP\_SYNC\_NOT\_ENABLED**

The application issued this verb within a callback routine, using the synchronous NOF entry point. Any verb issued from a callback routine must use the asynchronous entry point.

## State check

---

If the verb does not execute because of a state check, CS/AIX returns the following parameters.

***primary\_rc***

AP\_STATE\_CHECK

***secondary\_rc***

One of the following:

**AP\_CANT\_MODIFY\_VISIBILITY**

You have attempted to define a resource with a name that is reserved for use internally by CS/AIX. Please choose a different name.

**AP\_FILE\_LOCK\_FAILED**

The application issued SET\_PROCESSING\_MODE to change to commit mode, but CS/AIX failed to get a lock on the configuration file. This can be because another NOF API application or CS/AIX component is already accessing the file.

**AP\_FILE\_UNLOCK\_FAILED**

The application issued SET\_PROCESSING\_MODE to change from commit mode to one of the other modes, but CS/AIX failed to release its lock on the configuration file. In order to free the file when this error occurs, CS/AIX closes the application's handle to the file. The application must issue OPEN\_FILE again, to obtain a new file handle, before attempting to issue any more verbs to this file.

**AP\_FILE\_UNAVAILABLE**

The connection to the target file has been lost.

**AP\_NOT\_CONTROLLER**

The target file is a copy of the domain configuration file, or of the sna.net file, on a server that is not the controller server. Verbs that modify these files must be issued to the controller server's copy of the files.

**AP\_SYNC\_PENDING**

This verb was issued using the synchronous NOF API entry point, but another synchronous verb was in progress. Only one synchronous verb can be in progress at any time.

## System error

---

If the verb does not execute because of an operating system error, CS/AIX returns the following parameters:

***primary\_rc*****AP\_UNEXPECTED\_SYSTEM\_ERROR**

An operating system call failed during processing of the verb.

### *secondary\_rc*

The secondary return code in this case is the return code from the operating system call.

UNIX

For the meaning of the operating system return code, see the file `/usr/include/errno.h` on the computer where the error occurred. Typically, the return code will indicate a condition such as memory shortage.

WINDOWS

For the meaning of the operating system return code, refer to your operating system documentation.

■■■■■

If the problem persists, consult your System Administrator.

If the verb was issued to change the target configuration (such as `DEFINE_*` or `DELETE_*`), or to perform an action (such as `START_*`), the application should issue the appropriate `QUERY_*` verb to determine whether the change or action succeeded. In particular, if this error occurs while processing a `DEFINE_*` or `DELETE_*` verb containing multiple data structures, the change can be incomplete.

---

## Appendix C. How to send your comments to IBM

We appreciate your input on our publications. Feel free to comment on the clarity, accuracy, and completeness of the information or provide any other feedback that you have.

Use one of the following methods to send your comments:

1. Use the feedback link at the bottom of Knowledge Center.
2. Use the feedback template below and send us an email at "[mhvrcfs@us.ibm.com](mailto:mhvrcfs@us.ibm.com)"
3. Mail the comments to the following address:

IBM Corporation  
Attention: MHVRCFS Reader's Comments  
Department H6MA, Building 707  
2455 South Road  
Poughkeepsie, NY 12601-5400  
US

---

### Email feedback template

Please cut and paste the template below into your email. Then fill in the required information.

- My name:
- My Company, University or Institution:
- The URL of the topic or web page you are commenting on:
- The text of your comment

If you are willing to talk to us about your comment, please feel free to include a phone number and the best time to reach you.

When you send comments to IBM, you grant IBM a nonexclusive right to use or distribute the comments in any way appropriate without incurring any obligation to you.

IBM or any other organizations use the personal information that you supply to contact you only about the issues that you submit.

---

### If you have a technical problem

Do not use the feedback methods that are listed for sending reader's comments. Instead, take one of the following actions:

- Contact your IBM service representative
- Call IBM technical support
- Visit the IBM support portal at <https://www.ibm.com/support/home/>.



---

## Appendix D. Notices

This information was developed for products and services offered in the U.S.A. IBM may not offer the products, services, or features discussed in this document in other countries. Consult your local IBM representative for information on the products and services currently available in your area. Any reference to an IBM product, program, or service is not intended to state or imply that only that IBM product, program, or service may be used. Any functionally equivalent product, program, or service that does not infringe any IBM intellectual property right may be used instead. However, it is the user's responsibility to evaluate and verify the operation of any non-IBM product, program, or service.

IBM may have patents or pending patent applications covering subject matter described in this document. The furnishing of this document does not give you any license to these patents. You can send license inquiries, in writing, to:

- IBM Director of Licensing
- IBM Corporation
- North Castle Drive
- Armonk, NY 10504-1785
- U.S.A.

For license inquiries regarding double-byte (DBCS) information, contact the IBM Intellectual Property Department in your country or send inquiries, in writing, to:

- IBM World Trade Asia Corporation
- Licensing
- 2-31 Roppongi 3-chome, Minato-ku
- Tokyo 106, Japan

**The following paragraph does not apply to the United Kingdom or any other country where such provisions are inconsistent with local law:** INTERNATIONAL BUSINESS MACHINES CORPORATION PROVIDES THIS PUBLICATION "AS IS" WITHOUT WARRANTY OF ANY KIND, EITHER EXPRESS OR IMPLIED, INCLUDING, BUT NOT LIMITED TO, THE IMPLIED WARRANTIES OF NON-INFRINGEMENT, MERCHANTABILITY OR FITNESS FOR A PARTICULAR PURPOSE. Some states do not allow disclaimer of express or implied warranties in certain transactions, therefore, this statement may not apply to you.

This information could include technical inaccuracies or typographical errors. Changes are periodically made to the information herein; these changes will be incorporated in new editions of the publication. IBM may make improvements and/or changes in the product(s) and/or the program(s) described in this publication at any time without notice.

Any references in this information to non-IBM Web sites are provided for convenience only and do not in any manner serve as an endorsement of those Web sites. The materials at those Web sites are not part of the materials for this IBM product and use of those Web sites is at your own risk.

IBM may use or distribute any of the information you supply in any way it believes appropriate without incurring any obligation to you.

Licensees of this program who wish to have information about it for the purpose of enabling: (i) the exchange of information between independently created programs and other programs (including this one) and (ii) the mutual use of the information which has been exchanged, should contact:

- IBM Corporation
- P.O. Box 12195
- 3039 Cornwallis Road
- Research Triangle Park, NC 27709-2195
- U.S.A.

Such information may be available, subject to appropriate terms and conditions, including in some cases, payment of a fee.

The licensed program described in this information and all licensed material available for it are provided by IBM under terms of the IBM Customer Agreement, IBM International Program License Agreement, or any equivalent agreement between us.

Any performance data contained herein was determined in a controlled environment. Therefore, the results obtained in other operating environments may vary significantly. Some measurements may have been made on development-level systems and there is no guarantee that these measurements will be the same on generally available systems. Furthermore, some measurements may have been estimated through extrapolation. Actual results may vary. Users of this document should verify the applicable data for their specific environment.

Information concerning non-IBM products was obtained from the suppliers of those products, their published announcements or other publicly available sources. IBM has not tested those products and cannot confirm the accuracy of performance, compatibility or any other claims related to non-IBM products. Questions on the capabilities of non-IBM products should be addressed to the suppliers of those products.

This information contains examples of data and reports used in daily business operations. To illustrate them as completely as possible, the examples include the names of individuals, companies, brands, and products. All of these names are fictitious and any similarity to the names and addresses used by an actual business enterprise is entirely coincidental.

**COPYRIGHT LICENSE:** This information contains sample application programs in source language, which illustrates programming techniques on various operating platforms. You may copy, modify, and distribute these sample programs in any form without payment to IBM, for the purposes of developing, using, marketing or distributing application programs conforming to the application programming interface for the operating platform for which the sample programs are written. These examples have not been thoroughly tested under all conditions. IBM, therefore, cannot guarantee or imply reliability, serviceability, or function of these programs. You may copy, modify, and distribute these sample programs in any form without payment to IBM, for the purposes of developing, using, marketing or distributing application programs conforming to IBM's application programming interfaces.

Each copy or any portion of these sample programs or any derivative work must include a copyright notice as follows: © (your company name) (year). Portions of this code are derived from IBM Corp. Sample Programs. © Copyright IBM Corp. 2000, 2005, 2006, 2007, 2008, 2021. All rights reserved.

## Trademarks

---

The following terms are trademarks of the IBM Corporation in the United States or other countries or both:



- ACF/VTAM
- Advanced Peer-to-Peer Networking
- AIX
- Application System/400
- APPN
- AS/400
- CICS
- DATABASE 2
- DB2
- Enterprise System/3090
- Enterprise System/4381
- Enterprise System/9000
- ES/3090
- ES/9000
- eServer
- IBM
- IBMLink
- IMS
- MVS
- MVS/ESA
- Operating System/2
- Operating System/400
- OS/2
- OS/400
- PowerPC
- PowerPC Architecture
- S/390
- System/390
- System p5
- System z
- System z9
- VSE/ESA
- VTAM
- WebSphere

The following terms are trademarks or registered trademarks of other companies:

Java and all Java-based trademarks are trademarks of Sun Microsystems, Inc., in the United States, other countries, or both.

UNIX is a registered trademark in the United States and other countries licensed exclusively through The Open Group.

Intel and EM64T are trademarks of Intel Corporation.

AMD64 is a trademark of Advanced Micro Devices, Inc.

Linux is a trademark of Linus Torvalds.

RedHat and RPM are trademarks of Red Hat, Inc.

SuSE Linux is a trademark of Novell.

Ubuntu is a trademark of Canonical Limited.

Microsoft, Windows, Windows 10, Windows Server 2012, Windows Server 2016, Windows Server 2019 and the Windows logo are trademarks of Microsoft Corporation in the United States, other countries, or both.

Other company, product, and service names may be trademarks or service marks of others.



## Bibliography

---

The following IBM publications provide information about the topics discussed in this library. The publications are divided into the following broad topic areas:

- CS/AIX, Version 7.1
- Redbooks
- AIX operating system
- Systems Network Architecture (SNA)
- Host configuration
- z/OS Communications Server
- Transmission Control Protocol/Internet Protocol (TCP/IP)
- X.25
- Advanced Program-to-Program Communication (APPC)
- Programming
- Other IBM networking topics

For books in the CS/AIX library, brief descriptions are provided. For other books, only the titles and order numbers are shown here.

### CS/AIX version 7.1 publications

---

The CS/AIX library comprises the following books. In addition, softcopy versions of these documents are provided on the CD-ROM. See *IBM Communications Server for Data Center Deployment on AIX Quick Beginnings* for information about accessing the softcopy files on the CD-ROM. To install these softcopy books on your system, you require 9-15 MB of hard disk space (depending on which national language versions you install).

- *IBM Communications Server for Data Center Deployment on AIX Migration Guide* (SC31-8585)  
This book explains how to migrate from Communications Server for AIX Version 4 Release 2 or earlier to CS/AIX Version 6.
- *IBM Communications Server for Data Center Deployment on AIX Quick Beginnings* (GC31-8583)  
This book is a general introduction to CS/AIX, including information about supported network characteristics, installation, configuration, and operation.
- *IBM Communications Server for Data Center Deployment on AIX Administration Guide* (SC31-8586)  
This book provides an SNA and CS/AIX overview and information about CS/AIX configuration and operation.
- *IBM Communications Server for Data Center Deployment on AIX Administration Command Reference* (SC31-8587)  
This book provides information about SNA and CS/AIX commands.
- *IBM Communications Server for Data Center Deployment on AIX or Linux CPI-C Programmer's Guide* (SC23-8591)  
This book provides information for experienced 'C' or Java™ programmers about writing SNA transaction programs using the CS/AIX CPI Communications API.
- *IBM Communications Server for Data Center Deployment on AIX or Linux APPC Programmer's Guide* (SC23-8592)  
This book contains the information you need to write application programs using Advanced Program-to-Program Communication (APPC).

- *IBM Communications Server for Data Center Deployment on AIX or Linux LUA Programmer's Guide* (SC23-8590)

This book contains the information you need to write applications using the Conventional LU Application Programming Interface (LUA).

- *IBM Communications Server for Data Center Deployment on AIX or Linux CSV Programmer's Guide* (SC23-8589)

This book contains the information you need to write application programs using the Common Service Verbs (CSV) application program interface (API).

- *IBM Communications Server for Data Center Deployment on AIX or Linux MS Programmer's Guide* (SC23-8596)

This book contains the information you need to write applications using the Management Services (MS) API.

- *IBM Communications Server for Data Center Deployment on AIX NOF Programmer's Guide* (SC31-8595)

This book contains the information you need to write applications using the Node Operator Facility (NOF) API.

- *IBM Communications Server for Data Center Deployment on AIX Diagnostics Guide* (SC31-8588)

This book provides information about SNA network problem resolution.

- *IBM Communications Server for Data Center Deployment on AIX or Linux APPC Application Suite User's Guide*(SC23-8595)

This book provides information about APPC applications used with CS/AIX.

- *IBM Communications Server for Data Center Deployment on AIX Glossary* (GC31-8589)

This book provides a comprehensive list of terms and definitions used throughout the CS/AIX library.

## IBM Redbooks

---

IBM maintains an International Technical Support Center that produces publications known as Redbooks. Similar to product documentation, Redbooks cover theoretical and practical aspects of SNA technology. However, they do not include the information that is supplied with purchased networking products.

The following books contain information that may be useful for CS/AIX:

- *IBM Communications Server for AIX Version 6*(SG24-5947)
- *IBM CS/AIX Understanding and Migrating to Version 5: Part 2 - Performance* (SG24-2136)
- *Load Balancing for Communications Servers*(SG24-5305)

On the World Wide Web, users can download Redbook publications by using <http://www.redbooks.ibm.com>.

## AIX operating system publications

---

The following books contain information about the AIX operating system:

- *AIX Version 5.3 System Management Guide: Operating System and Devices* (SC23-4910)
- *AIX Version 5.3 System Management Concepts: Operating System and Devices* (SC23-4908)
- *AIX Version 5.3 System Management Guide: Communications and Networks* (SC23-4909)
- *AIX Version 5.3 Performance Management Guide* (SC23-4905)
- *AIX Version 5.3 Performance Tools Guide and Reference* (SC23-4906)
- *Performance Toolbox Version 2 and 3 Guide and Reference* (SC23-2625)
- *AIX Version 5.3 Communications Programming Concepts* (SC23-4894)
- *AIX Version 5.3 Installation Guide and Reference* (SC23-4887)

- *AIXlink/X.25 Version 2.1 for AIX: Guide and Reference* (SC23-2520)

## Systems Network Architecture (SNA) publications

---

The following books contain information about SNA networks:

- *Systems Network Architecture: Format and Protocol Reference Manual - Architecture Logic for LU Type 6.2* (SC30-3269)
- *Systems Network Architecture: Formats* (GA27-3136)
- *Systems Network Architecture: Guide to SNA Publications* (GC30-3438)
- *Systems Network Architecture: Network Product Formats* (LY43-0081)
- *Systems Network Architecture: Technical Overview* (GC30-3073)
- *Systems Network Architecture: APPN Architecture Reference* (SC30-3422)
- *Systems Network Architecture: Sessions between Logical Units* (GC20-1868)
- *Systems Network Architecture: LU 6.2 Reference - Peer Protocols* (SC31-6808)
- *Systems Network Architecture: Transaction Programmer's Reference Manual for LU Type 6.2* (GC30-3084)
- *Systems Network Architecture: 3270 Datastream Programmer's Reference* (GA23-0059)
- *Networking Blueprint Executive Overview* (GC31-7057)
- *Systems Network Architecture: Management Services Reference* (SC30-3346)

## Host configuration publications

---

The following books contain information about host configuration:

- *ES-9000, ES-3090 IOCP User's Guide Volume A04* (GC38-0097)
- *3174 Establishment Controller Installation Guide* (GG24-3061)
- *3270 Information Display System 3174 Establishment Controller: Planning Guide* (GA27-3918)
- *OS/390 Hardware Configuration Definition (HCD) User's Guide* (SC28-1848)
- *ESCON Director Planning*(GA23-0364)

## z/OS Communications Server publications

---

The following books contain information about z/OS Communications Server:

- *z/OS V1R7 Communications Server: SNA Network Implementation Guide* (SC31-8777)
- *z/OS V1R7 Communications Server: SNA Diagnostics* (Vol 1: GC31-6850, Vol 2: GC31-6851)
- *z/OS V1R6 Communications Server: Resource Definition Reference* (SC31-8778)

## TCP/IP publications

---

The following books contain information about the Transmission Control Protocol/Internet Protocol (TCP/IP) network protocol:

- *z/OS V1R7 Communications Server: IP Configuration Guide* (SC31-8775)
- *z/OS V1R7 Communications Server: IP Configuration Reference* (SC31-8776)
- *z/VM V5R1 TCP/IP Planning and Customization* (SC24-6125)

## X.25 publications

---

The following books contain information about the X.25 network protocol:

- *AIXLink/X.25 for AIX: Guide and Reference* (SC23-2520)

- *RS/6000 AIXLink/X.25 Cookbook*(SG24-4475)
- *Communications Server for OS/2 Version 4 X.25 Programming* (SC31-8150)

## APPC publications

---

The following books contain information about Advanced Program-to-Program Communication (APPC):

- *APPC Application Suite V1 User's Guide* (SC31-6532)
- *APPC Application Suite V1 Administration* (SC31-6533)
- *APPC Application Suite V1 Programming* (SC31-6534)
- *APPC Application Suite V1 Online Product Library* (SK2T-2680)
- *APPC Application Suite Licensed Program Specifications* (GC31-6535)
- *z/OS V1R2.0 Communications Server: APPC Application Suite User's Guide* (SC31-8809)

## Programming publications

---

The following books contain information about programming:

- *Common Programming Interface Communications CPI-C Reference* (SC26-4399)
- *Communications Server for OS/2 Version 4 Application Programming Guide* (SC31-8152)

## Other IBM networking publications

---

The following books contain information about other topics related to CS/AIX:

- *SDLC Concepts*(GA27-3093)
- *Local Area Network Concepts and Products: LAN Architecture* (SG24-4753)
- *Local Area Network Concepts and Products: LAN Adapters, Hubs and ATM* (SG24-4754)
- *Local Area Network Concepts and Products: Routers and Gateways* (SG24-4755)
- *Local Area Network Concepts and Products: LAN Operating Systems and Management* (SG24-4756)
- *IBM Network Control Program Resource Definition Guide* (SC30-3349)

---

# Index

## A

access list, conversation security [177](#)  
ACTIVATE\_SESSION [35](#)  
activating a session [35](#)  
ADD\_BACKUP [38](#)  
ADD\_DLC\_TRACE [39](#)  
AIX applications  
    compiling and linking [24](#)  
APING [42](#)  
APPN node [2](#)  
asynchronous entry point  
    AIX or Linux [20](#)  
    callback routine [23](#)  
    callback routine, Windows [28](#)  
    overview [21](#)  
    Windows [25](#), [26](#)  
audit log file [372](#), [568](#)

## B

backup server  
    adding [38](#)  
    deleting [208](#)

## C

callback routine  
    overview [23](#)  
    overview, Windows [28](#)  
    requirements [24](#)  
    supplied to REGISTER\_\* verbs [24](#)  
central logging [266](#), [267](#), [562](#)  
CHANGE\_SESSION\_LIMIT [46](#)  
changing session limits [46](#)  
checking communications path to remote LU [42](#)  
child process [24](#)  
client/server operation [3](#)  
clients  
    querying [492](#)  
CLOSE\_FILE [50](#)  
closing a configuration file [50](#)  
closing the sna.net file [50](#)  
CN [59](#), [269](#)  
CN ports [273](#)  
comments on publication  
    sending feedback [665](#)  
comp\_proc (callback routine)  
    Windows [27](#)  
compiling AIX applications [24](#)  
compiling and linking  
    Windows [29](#)  
compiling Linux applications [24](#)  
CONFIG\_INDICATION [17](#), [599](#)  
configuration file  
    closing [50](#)  
    domain resources [2](#)

configuration file (*continued*)  
    header information [81](#), [331](#)  
    node [2](#)  
    opening [252](#)  
configuration indication [17](#)  
configuration, node [2](#)  
CONNECT\_NODE [51](#)  
controller server [4](#)  
corr (correlator)  
    Windows [28](#), [29](#)  
COS  
    defining [62](#)  
    getting information [279](#)  
    node row [281](#)  
    TG row [284](#)  
CPI-C, side information [67](#), [289](#)

## D

data file  
    invokable TP [2](#)  
    TP definition [2](#)  
DEACTIVATE\_CONV\_GROUP [52](#)  
DEACTIVATE\_LU\_0\_TO\_3 [54](#)  
DEACTIVATE\_SESSION [55](#)  
deactivating a session  
    LU type 0-3 [54](#)  
    LU type 6.2 [55](#)  
DEFINE\_ADJACENT\_LEN\_NODE [57](#)  
DEFINE\_CN [59](#)  
DEFINE\_COS [62](#)  
DEFINE\_CPIC\_SIDE\_INFO [67](#)  
DEFINE\_DEFAULT\_PU [69](#)  
DEFINE\_DEFAULTS [70](#)  
DEFINE\_DIRECTORY\_ENTRY [72](#)  
DEFINE\_DLC [74](#)  
DEFINE\_DLUR\_DEFAULTS [79](#)  
DEFINE\_DOMAIN\_CONFIG\_FILE [81](#)  
DEFINE\_DOWNSTREAM\_LU [82](#)  
DEFINE\_DOWNSTREAM\_LU\_RANGE [85](#)  
DEFINE\_DSPU\_TEMPLATE [88](#)  
DEFINE\_FOCAL\_POINT [91](#)  
DEFINE\_INTERNAL\_PU [93](#)  
DEFINE\_LOCAL\_LU [96](#)  
DEFINE\_LS [100](#)  
DEFINE\_LS\_ROUTING verb [127](#)  
DEFINE\_LU\_0\_TO\_3 [130](#)  
DEFINE\_LU\_0\_TO\_3\_RANGE [134](#)  
DEFINE\_LU\_LU\_PASSWORD [138](#)  
DEFINE\_LU\_POOL [140](#)  
DEFINE\_LU62\_TIMEOUT [129](#)  
DEFINE\_MODE [141](#)  
DEFINE\_PARTNER\_LU [156](#)  
DEFINE\_PORT [159](#)  
DEFINE\_RCF\_ACCESS [174](#)  
DEFINE\_RTP\_TUNING [175](#)  
DEFINE\_SECURITY\_ACCESS\_LIST [177](#)

[DEFINE\\_TN\\_REDIRECT](#) [194](#)  
[DEFINE\\_TN3270\\_ACCESS](#) [179](#)  
[DEFINE\\_TN3270\\_ASSOCIATION](#) [185](#)  
[DEFINE\\_TN3270\\_DEFAULTS](#) [187](#)  
[DEFINE\\_TN3270\\_EXPRESS\\_LOGON](#) [188](#)  
[DEFINE\\_TN3270\\_SLP](#) [190](#)  
[DEFINE\\_TN3270\\_SSL\\_LDAP](#) [192](#)  
[DEFINE\\_TP](#) [199](#)  
[DEFINE\\_TP\\_LOAD\\_INFO](#) [202](#)  
[DEFINE\\_USERID\\_PASSWORD](#) [205](#)  
[DELETE\\_ADJACENT\\_LEN\\_NODE](#) [207](#)  
[DELETE\\_BACKUP](#) [208](#)  
[DELETE\\_CN](#) [209](#)  
[DELETE\\_COS](#) [211](#)  
[DELETE\\_CPIC\\_SIDE\\_INFO](#) [212](#)  
[DELETE\\_DIRECTORY\\_ENTRY](#) [213](#)  
[DELETE\\_DLC](#) [214](#)  
[DELETE\\_DOWNSTREAM\\_LU](#) [215](#)  
[DELETE\\_DOWNSTREAM\\_LU\\_RANGE](#) [217](#)  
[DELETE\\_DSPU\\_TEMPLATE](#) [218](#)  
[DELETE\\_FOCAL\\_POINT](#) [220](#)  
[DELETE\\_INTERNAL\\_PU](#) [222](#)  
[DELETE\\_LOCAL\\_LU](#) [223](#)  
[DELETE\\_LS](#) [224](#)  
[DELETE\\_LS\\_ROUTING](#) [225](#)  
[DELETE\\_LU\\_0\\_TO\\_3](#) [228](#)  
[DELETE\\_LU\\_0\\_TO\\_3\\_RANGE](#) [229](#)  
[DELETE\\_LU\\_LU\\_PASSWORD](#) [231](#)  
[DELETE\\_LU\\_POOL](#) [232](#)  
[DELETE\\_LU62\\_TIMEOUT](#) [227](#)  
[DELETE\\_MODE](#) [233](#)  
[DELETE\\_PARTNER\\_LU](#) [234](#)  
[DELETE\\_PORT](#) [235](#)  
[DELETE\\_RCF\\_ACCESS](#) [236](#)  
[DELETE\\_SECURITY\\_ACCESS\\_LIST](#) [237](#)  
[DELETE\\_TN\\_REDIRECT](#) [242](#)  
[DELETE\\_TN3270\\_ACCESS](#) [238](#)  
[DELETE\\_TN3270\\_ASSOCIATION](#) [240](#)  
[DELETE\\_TP](#) [243](#)  
[DELETE\\_TP\\_LOAD\\_INFO](#) [244](#)  
[DELETE\\_USERID\\_PASSWORD](#) [245](#)  
 directory entry  
     defining [72](#)  
     deleting [213](#)  
     getting information [297](#)  
     LU [303](#)  
 directory statistics [307](#)  
[DIRECTORY\\_INDICATION](#) [600](#)  
[DISCONNECT\\_NODE](#) [247](#)  
 DLC  
     defining [74](#)  
     querying [308](#)  
     starting [583](#)  
     stopping [590](#)  
[DLC\\_INDICATION](#) [602](#)  
 DLUR  
     default DLUS [79](#)  
     LU [318](#)  
     PU [322](#)  
     support [33](#)  
[DLUR\\_LU\\_INDICATION](#) [603](#)  
[DLUR\\_PU\\_INDICATION](#) [604](#)  
[DLUS](#) [327](#)  
[DLUS\\_INDICATION](#) [606](#)

[domain configuration](#) [4](#)  
[domain configuration file](#)  
     on multiple servers [4](#)  
[domain resources, configuration file](#) [2](#)  
[downstream LU](#) [82](#), [85](#), [332](#)  
[downstream PU](#) [339](#)  
[DOWNSTREAM\\_LU\\_INDICATION](#) [608](#)  
[DOWNSTREAM\\_PU\\_INDICATION](#) [611](#)  
[DSPU template](#) [343](#)

## E

[end node](#) [32](#)  
[entry points](#)  
     AIX or Linux [19](#)  
     Windows [25](#)  
[error log file](#) [372](#), [568](#)  
[Express Logon](#) [188](#)

## F

[feedback](#)  
     email template [665](#)  
     sending reader comments [665](#)  
[FNA](#) [111](#)  
[focal point](#) [91](#), [346](#)  
[FOCAL\\_POINT\\_INDICATION](#) [613](#)

## H

[hexadecimal values for NOF parameters](#) [35](#)  
[HNA](#) [111](#)

## I

[indications](#)  
     overview [16](#), [599](#)  
     registering for [553](#)  
     unregistering [597](#)  
[INIT\\_NODE](#) [248](#)  
[INITIALIZE\\_SESSION\\_LIMIT](#) [249](#)  
[invokable TP](#)  
     data file [2](#)  
     defining [199](#)  
     getting information [262](#)  
[invokable TP data file](#) [200](#)  
[ISR session](#) [352](#)  
[ISR\\_INDICATION](#) [614](#)

## K

[kernel components, memory usage](#) [359](#), [567](#)

## L

[LEN node](#) [32](#)  
[licensing limits](#) [466](#)  
[link station routing](#)  
     defining [127](#)  
     deleting [225](#)  
     querying [395](#)  
[linking AIX applications](#) [24](#)



- linking Linux applications [24](#)
- Linux applications
  - compiling and linking [24](#)
- list options for QUERY\_\* verbs [33](#)
- local LU
  - conversations [275](#)
  - defining [96](#)
  - querying [360](#)
  - sessions [508](#)
- local topology [367](#)
- LOCAL\_LU\_INDICATION [617](#)
- LOCAL\_TOPOLOGY\_INDICATION [620](#)
- log file [372](#), [568](#)
- log message type [350](#), [373](#), [565](#), [571](#)
- log messages
  - central logging [266](#), [267](#)
- log messages, central logging [562](#)
- LS
  - defining [100](#)
  - querying [375](#)
  - starting [586](#)
  - statistics [517](#)
  - stopping [593](#)
- LS\_INDICATION [621](#)
- LU pool
  - defining [140](#)
  - querying [412](#)
- LU type 0-3 [130](#), [134](#)
- LU type 6.2 timeout
  - defining [129](#)
  - deleting [227](#)
  - querying [416](#)
- LU\_0\_TO\_3\_INDICATION [625](#)
- LU-LU password [138](#), [409](#)

## M

- MAC address, Token Ring / Ethernet [125](#)
- Management Services
  - active applications [419](#)
  - active transactions [256](#)
  - default PU [69](#), [294](#)
  - focal point [91](#), [346](#)
  - statistics [421](#)
- MDS application [419](#)
- MDS statistics [421](#)
- MDS support [33](#)
- memory usage, kernel components [359](#), [567](#)
- mode
  - defining [141](#)
  - mapping to COS [433](#)
- MODE\_INDICATION [628](#)
- multiple processes [24](#)
- multiple servers on a LAN [4](#)

## N

- network node
  - restrictions [32](#)
  - topology [438](#), [446](#)
- network topology
  - querying [367](#), [438](#), [446](#)
  - statistics [443](#)

- NN\_TOPOLOGY\_NODE\_INDICATION [629](#)
- NN\_TOPOLOGY\_TG\_INDICATION [630](#)
- node
  - connecting to [51](#)
  - defining [145](#)
  - implementation of [2](#)
  - limits [466](#)
  - options [466](#)
  - querying [452](#), [464](#)
  - resource usage [466](#)
  - starting [248](#)
  - stopping [596](#)
- node configuration file [2](#)
- node type, APPN [32](#)
- NOF API overview [1](#)
- nof entry point
  - AIX or Linux [20](#)
  - description [20](#)
  - returned values [21](#)
  - supplied parameters [20](#)
  - Windows [25](#)
- NOF verbs
  - common return codes [661](#)
  - order in which issued [31](#)
  - overview [35](#)
  - restrictions based on node configuration [32](#)
- nof\_async entry point
  - AIX or Linux [20](#)
  - callback routine [23](#)
  - callback routine, Windows [28](#)
  - description [21](#)
  - returned values [22](#)
  - returned values, Windows [28](#)
  - supplied parameters [22](#)
  - supplied parameters, Windows [27](#)
  - Windows [25](#), [26](#)
- NOF\_STATUS\_INDICATION [17](#), [632](#)
- nofvcb structure
  - Windows [26](#), [27](#)

## O

- OPEN\_FILE [252](#)
- opening a configuration file [252](#)
- opening thesna.net file [252](#)

## P

- partner LU
  - defining [156](#)
  - getting information [469](#), [475](#)
  - method of locating [127](#), [225](#), [395](#)
- password
  - conversation security [205](#), [551](#)
  - LU-LU [138](#), [409](#)
  - session-level security [409](#)
- PATH\_SWITCH [254](#)
- PLU\_INDICATION [633](#)
- pool, LU [140](#), [412](#)
- port
  - defining [159](#)
  - querying [479](#)
  - starting [588](#)

port (*continued*)  
stopping [594](#)  
PORT\_INDICATION [634](#)  
primary return codes [653](#)  
processing mode [31](#), [573](#)  
PU [487](#)  
PU\_INDICATION [635](#)

## Q

QUERY\_\* verbs  
detailed information [34](#)  
list options [33](#)  
returning information about multiple resources [33](#)  
summary information [34](#)  
QUERY\_ACTIVE\_TRANSACTION [256](#)  
QUERY\_ADJACENT\_NN [259](#)  
QUERY\_AVAILABLE\_TP [262](#)  
QUERY\_BUFFER\_AVAILABILITY [264](#)  
QUERY\_CENTRAL\_LOGGER [266](#)  
QUERY\_CENTRAL\_LOGGING [267](#)  
QUERY\_CN [269](#)  
QUERY\_CN\_PORT [273](#)  
QUERY\_CONVERSATION [275](#)  
QUERY\_COS [279](#)  
QUERY\_COS\_NODE\_ROW [281](#)  
QUERY\_COS\_TG\_ROW [284](#)  
QUERY\_CPIC\_SIDE\_INFO [289](#)  
QUERY\_CS\_TRACE [293](#)  
QUERY\_DEFAULT\_PU [294](#)  
QUERY\_DEFAULTS [295](#)  
QUERY\_DIRECTORY\_ENTRY [297](#)  
QUERY\_DIRECTORY\_LU [303](#)  
QUERY\_DIRECTORY\_STATS [307](#)  
QUERY\_DLC [308](#)  
QUERY\_DLC\_TRACE [313](#)  
QUERY\_DLUR\_DEFAULTS [317](#)  
QUERY\_DLUR\_LU [318](#)  
QUERY\_DLUR\_PU [322](#)  
QUERY\_DLUS [327](#)  
QUERY\_DOMAIN\_CONFIG\_FILE [331](#)  
QUERY\_DOWNSTREAM\_LU [332](#)  
QUERY\_DOWNSTREAM\_PU [339](#)  
QUERY\_DSPU\_TEMPLATE [343](#)  
QUERY\_FOCAL\_POINT [346](#)  
QUERY\_GLOBAL\_LOG\_TYPE [350](#)  
QUERY\_ISR\_SESSION [352](#)  
QUERY\_KERNEL\_MEMORY\_LIMIT [359](#)  
QUERY\_LOCAL\_LU [360](#)  
QUERY\_LOCAL\_TOPOLOGY [367](#)  
QUERY\_LOG\_FILE [372](#)  
QUERY\_LOG\_TYPE [373](#)  
QUERY\_LS [375](#)  
QUERY\_LS\_ROUTING [395](#)  
QUERY\_LU\_0\_TO\_3 [397](#)  
QUERY\_LU\_LU\_PASSWORD [409](#)  
QUERY\_LU\_POOL [412](#)  
QUERY\_LU62\_TIMEOUT [416](#)  
QUERY\_MDS\_APPLICATION [419](#)  
QUERY\_MDS\_STATISTICS [421](#)  
QUERY\_MODE [423](#)  
QUERY\_MODE\_DEFINITION [429](#)  
QUERY\_MODE\_TO\_COS\_MAPPING [433](#)  
QUERY\_NN\_TOPOLOGY\_NODE [438](#)

QUERY\_NN\_TOPOLOGY\_STATS [443](#)  
QUERY\_NN\_TOPOLOGY\_TG [446](#)  
QUERY\_NODE [452](#)  
QUERY\_NODE\_ALL [464](#)  
QUERY\_NODE\_LIMITS [466](#)  
QUERY\_PARTNER\_LU [469](#)  
QUERY\_PARTNER\_LU\_DEFINITION [475](#)  
QUERY\_PORT [479](#)  
QUERY\_PU [487](#)  
QUERY\_RAPI\_CLIENTS [492](#)  
QUERY\_RCF\_ACCESS [495](#)  
QUERY\_RTP\_CONNECTION [496](#)  
QUERY\_RTP\_TUNING [503](#)  
QUERY\_SECURITY\_ACCESS\_LIST [505](#)  
QUERY\_SESSION [508](#)  
QUERY\_SNA\_NET [515](#)  
QUERY\_STATISTICS [517](#)  
QUERY\_TN\_REDIRECT\_DEF [535](#)  
QUERY\_TN\_SERVER\_TRACE [537](#)  
QUERY\_TN3270\_ACCESS\_DEF [521](#)  
QUERY\_TN3270\_ASSOCIATION [526](#)  
QUERY\_TN3270\_DEFAULTS [528](#)  
QUERY\_TN3270\_EXPRESS\_LOGON [529](#)  
QUERY\_TN3270\_SLP [530](#)  
QUERY\_TN3270\_SLP\_TRACE [532](#)  
QUERY\_TN3270\_SSL\_LDAP [533](#)  
QUERY\_TP [538](#)  
QUERY\_TP\_DEFINITION [541](#)  
QUERY\_TP\_LOAD\_INFO [545](#)  
QUERY\_TRACE\_FILE [548](#)  
QUERY\_TRACE\_TYPE [549](#)  
QUERY\_USERID\_PASSWORD [551](#)

## R

RAPI\_CLIENT\_INDICATION [637](#)  
RCF  
access [495](#)  
defining [174](#)  
preventing access [236](#)  
reader comments  
methods of sending feedback [665](#)  
REGISTER\_INDICATION\_SINK [553](#)  
registering for indications [553](#)  
REGISTRATION\_FAILURE [639](#)  
Remote API Client  
querying [492](#)  
REMOVE\_DLC\_TRACE [555](#)  
RESET\_SESSION\_LIMIT [558](#)  
return codes  
primary [653](#)  
secondary [654](#)  
return codes, common [661](#)  
RTP connections  
parameters [175](#), [503](#)  
querying [496](#)  
switching path [254](#)  
RTP\_INDICATION [640](#)

## S

secondary return codes [654](#)  
server [4](#)

- SERVER\_INDICATION [644](#)
- session limits
  - initializing [249](#)
  - resetting [558](#)
- SESSION\_INDICATION [645](#)
- SET\_BUFFER\_AVAILABILITY [562](#)
- SET\_CENTRAL\_LOGGING [562](#)
- SET\_CS\_TRACE [563](#)
- SET\_GLOBAL\_LOG\_TYPE [565](#)
- SET\_KERNEL\_MEMORY\_LIMIT [567](#)
- SET\_LOG\_FILE [568](#)
- SET\_LOG\_TYPE [571](#)
- SET\_PROCESSING\_MODE [31](#), [573](#)
- SET\_TN\_SERVER\_TRACE [576](#)
- SET\_TN3270\_SLP\_TRACE [575](#)
- SET\_TRACE\_FILE [577](#)
- SET\_TRACE\_TYPE [579](#)
- side information, CPI-C [67](#), [289](#)
- SNA gateway support [33](#)
- SNA network file indication [17](#)
- SNA\_NET\_INDICATION [17](#), [648](#)
- sna.net file
  - adding a backup server [38](#)
  - closing [50](#)
  - deleting a backup server [208](#)
  - opening [252](#)
  - querying backup servers [515](#)
- SPCF
  - access [495](#)
  - defining [174](#)
- START\_DLC [583](#)
- START\_INTERNAL\_PU [584](#)
- START\_LS [586](#)
- START\_PORT [588](#)
- statistics
  - LS [517](#)
  - network topology [443](#)
- status indication [17](#)
- STOP\_DLC [590](#)
- STOP\_INTERNAL\_PU [591](#)
- STOP\_LS [593](#)
- STOP\_PORT [594](#)
- STREAMS buffers [264](#), [562](#)
- STREAMS components [3](#)
- synchronous entry point
  - AIX or Linux [20](#)
  - Windows [25](#)

## T

- target for NOF verbs [30](#)
- target handle
  - Windows [26](#), [27](#)
- technical problems
  - methods of resolving [665](#)
- Telnet client
  - checking authorization [192](#)
  - express logon [188](#)
  - using TN Redirector [194](#), [535](#)
- TERM\_NODE [596](#)
- TN\_REDIRECTION\_INDICATION [649](#)
- TN3270 Express Logon [188](#)
- TN3270 user
  - using TN3270 Server [179](#), [521](#)

- TN3270 user (*continued*)
  - using TN3270 SLP [190](#)
- TP [199](#), [538](#), [541](#), [545](#)
- trace file [548](#), [577](#)
- trace type
  - CS trace [293](#), [563](#)
  - node DLC trace [39](#)
  - querying [549](#)
  - setting [579](#)
  - TN server trace [537](#), [576](#)
  - TN3270 SLP trace [532](#), [575](#)

## U

- UCF
  - access [495](#)
  - defining [174](#)
- UNREGISTER\_INDICATION\_SINK [597](#)
- usage log file [372](#), [568](#)
- user ID, conversation security [205](#), [551](#)

## V

- VCB structure, pointer to
  - Windows [26](#), [27](#)
- VCB structure, pointer to, Windows [29](#)







SC31-8595-06

