

IBM Db2 Analytics Accelerator for z/OS
5.1.9

User's Guide



Note

Before you use this information and the product it supports, read the information in [“Notices”](#) on page [265](#).

Eleventh Edition, July 2022

This edition applies to version 5.1.9 of IBM® Db2® Analytics Accelerator for z/OS® (product number 5697-DA5), and to all subsequent releases and modifications until otherwise indicated in new editions. This edition replaces SH12-7061-09. Changes to this edition are marked with a vertical bar.

© **Copyright International Business Machines Corporation 2010, 2022.**

US Government Users Restricted Rights – Use, duplication or disclosure restricted by GSA ADP Schedule Contract with IBM Corp.

Contents

- Figures..... ix**
- About this book..... xi**
- Who should read this book..... xiii**
- What's new in version 5?..... xv**
- Accessibility features..... xvii**

- Chapter 1. Introduction..... 1**
 - Connecting to a data server..... 1
 - Database connection profiles.....1
 - Connecting to a database.....1
 - Adding accelerators..... 1
 - Defining the data to load into an accelerator..... 2
 - Selecting the proper tables..... 2
 - Checking the table size.....2
 - Choosing a distribution key..... 2
 - Choosing an organizing key..... 3
 - Working with accelerator-shadow tables.....4
 - Loading data into selected tables..... 4
 - Enabling tables for query acceleration..... 4
 - Disabling query acceleration for a table..... 4
 - Enabling tables for incremental updates.....4
 - Disabling incremental updates..... 5
 - Moving partition or table data to an accelerator..... 5
 - Removing tables..... 5
 - Order in which to complete tasks..... 5

- Chapter 2. Basic concepts.....7**
 - Accelerator..... 7
 - Virtual accelerator.....7
 - Static SQL query support..... 7
 - Accelerator-shadow table.....8
 - How to select tables for query acceleration.....8
 - Distribution keys..... 11
 - Organizing keys..... 12
 - Zone maps.....13
 - Tables states..... 13
 - Accelerator-archive tables..... 15
 - Accelerator-only tables and in-database transformation..... 16
 - Workload balancing..... 20
 - IBM Db2 Analytics Accelerator for z/OS system table entries..... 20

- Chapter 3. Conditions for query routing to an accelerator.....21**
 - Configuring Db2 for z/OS for the acceleration of dynamic SQL queries..... 21
 - Configuring Db2 for z/OS for the acceleration of static SQL queries..... 23
 - Supported queries..... 26

| | |
|--|-----------|
| Supported data types..... | 27 |
| Supported SQL functions and expressions..... | 31 |
| Supported special registers..... | 35 |
| Conditions that prevent query routing to an accelerator..... | 37 |
| Isolation levels..... | 40 |
| Incompatibilities between Db2 for z/OS and IBM Db2 Analytics Accelerator for z/OS..... | 41 |
| Correlated subqueries..... | 41 |
| COUNT_BIG function..... | 41 |
| Data types..... | 41 |
| Division and multiplication of decimal values..... | 42 |
| Encoding issues..... | 43 |
| Exception handling..... | 43 |
| Maximum row length..... | 44 |
| Predicate evaluation..... | 44 |
| Scalar functions..... | 44 |
| SQL issues..... | 46 |
| Time and date values..... | 46 |
| Incompatibilities related to IBM InfoSphere Change Data Capture for z/OS..... | 48 |
| Restrictions of accelerator-only tables..... | 49 |
| New features in Db2 10 for z/OS..... | 52 |
| New features in Db2 11 for z/OS..... | 55 |
| Differences in floating-point error tolerances..... | 56 |
| Chapter 4. Administration clients..... | 57 |
| Interface elements of IBM Db2 Analytics Accelerator Studio..... | 58 |
| Menu bar..... | 58 |
| Administration Explorer | 58 |
| Object List Editor..... | 60 |
| Accelerator views..... | 64 |
| Interface elements of IBM Data Server Manager..... | 77 |
| Main menu..... | 78 |
| Accelerator view..... | 79 |
| List of tables..... | 85 |
| List of queries..... | 88 |
| Chapter 5. Administration tasks..... | 91 |
| Creating a database connection profile..... | 91 |
| Connecting to a database server..... | 95 |
| Exploring a database server..... | 98 |
| Adding accelerators..... | 99 |
| Obtaining the pairing code for authentication..... | 99 |
| Completing the authentication using the Add Accelerator wizard..... | 101 |
| Adding virtual accelerators (IBM Db2 Analytics Accelerator Studio only)..... | 103 |
| Displaying accelerator networking details..... | 104 |
| Defining tables on an accelerator..... | 104 |
| Determining the status of an accelerator..... | 107 |
| Enabling an accelerator..... | 108 |
| Disabling an accelerator..... | 109 |
| Preparing tables for workload balancing and accelerating static SQL queries..... | 110 |
| Enabling or disabling an accelerator for members of a data sharing group..... | 112 |
| Loading tables..... | 112 |
| Enabling tables for query acceleration..... | 117 |
| Disabling query acceleration for tables..... | 119 |
| Specifying or changing a distribution key or organizing keys..... | 120 |
| Synchronizing schemas (IBM Db2 Analytics Accelerator Studio only)..... | 124 |
| Running an SQL script from your administration client..... | 126 |
| Running IBM Netezza Analytics stored procedures..... | 128 |

| | |
|--|-----|
| EXPLAIN information..... | 129 |
| Displaying an access plan graph..... | 133 |
| Types of access plan graphs and nodes in these graphs..... | 134 |
| Selecting and ordering query monitoring columns..... | 138 |
| Selectable columns in the query history..... | 141 |
| Canceling tasks..... | 151 |
| Removing tables from an accelerator..... | 152 |
| Exporting a table specification..... | 153 |
| Importing a table specification..... | 154 |
| Removing accelerators..... | 154 |
| Tracing..... | 155 |
| Configuring the trace behavior..... | 155 |
| Saving trace information..... | 158 |
| Collecting CDC trace information..... | 162 |
| Configuring the FTP server for the Save Trace function..... | 163 |
| Clearing trace information and replication events..... | 164 |
| Monitoring accelerator usage metrics..... | 165 |
| Accelerator usage metrics..... | 165 |
| Viewing accelerator usage metrics..... | 170 |
| Setting a refresh interval or a skew threshold..... | 171 |
| Updating accelerator tables continually..... | 172 |
| Making queries wait for incremental updates..... | 173 |
| Starting or stopping incremental updates..... | 177 |
| Including or excluding tables from incremental updates..... | 178 |
| Monitoring incremental updates..... | 182 |
| Using the event viewer for incremental updates..... | 183 |
| Warnings related to incremental updates..... | 185 |
| Collecting CDC trace information..... | 186 |
| What to do after changing a table or table space in Db2 for z/OS..... | 187 |
| Freeing up storage in Db2 for z/OS..... | 188 |
| Archiving partition or table data with the High-Performance Storage Saver..... | 190 |
| Impact of special register settings..... | 194 |
| Restoring archived partitions..... | 196 |
| How to handle the RBA and LRSN conversion in Db2 11 for z/OS..... | 198 |
| Federated access..... | 198 |
| Granting access to remote tables..... | 201 |
| Creating reference tables..... | 202 |
| Revoking table access..... | 205 |
| Removing reference tables..... | 207 |
| Installing updates..... | 209 |
| Updating the IBM Db2 Analytics Accelerator software, the Netezza Platform Software (NPS), the Access Server, or the replication engine..... | 209 |
| Updating administration clients..... | 222 |
| Switching from 24:00:00 conversion to native 24:00:00 support..... | 225 |
| Viewing the encryption status..... | 227 |

Chapter 6. Opening a support case..... 229

Chapter 7. Status information about the system and the incremental update function..... 231

Chapter 8. Troubleshooting..... 235

| | |
|---|-----|
| Redundant CDC metadata..... | 235 |
| Firewall blocks operations because crucial ports are closed..... | 235 |
| IBM Db2 Analytics Accelerator Studio does not start..... | 236 |
| IBM Db2 Analytics Accelerator Studio on Linux does not start..... | 237 |
| Message AQT10200E and SQL code -206 when running stored procedures after migration..... | 237 |

| | |
|---|------------|
| Package not found when running a stored procedure from IBM Db2 Analytics Accelerator Studio.... | 237 |
| Removing orphaned system-table entries and catalog-table entries..... | 238 |
| Long-running tasks are not completed..... | 239 |
| SQL code -430 from IBM Db2 Analytics Accelerator for z/OS stored procedures..... | 240 |
| Database access problems after updating IBM Db2 Analytics Accelerator Studio or IBM Optim | |
| Query Tuner..... | 240 |
| DRDA connection does not work..... | 241 |
| Different results for floating-point aggregates..... | 241 |
| Replication column not shown..... | 242 |
| Replication status: ERROR | 242 |
| Table removal very slow..... | 243 |
| Repeated IBM InfoSphere Change Data Capture for z/OS errors after abnormal end of Db2 for z/OS | 243 |
| Stored procedure calls fail with message AQT10206I while temporary files are being created..... | 243 |
| Query history is not displayed - error message returned..... | 244 |
| Db2 for z/OS returns SQLCODE -30040..... | 244 |
| Query fails with SQLSTATE: HY000 SQLCODE: 46 'ERROR'..... | 245 |
| Restoring of archived partition fails with 'Duplicate key' error..... | 245 |
| Table definition fails with error message AQT1005I..... | 246 |
| SQL error as you try to enable tables for incremental updates..... | 247 |
| UNLOAD utility threads remain in STOPPED state..... | 247 |
| | |
| Appendix A. Mappings of product SQL codes to Db2 for z/OS SQL codes..... | 249 |
| | |
| Appendix B. Impact of special register, ZPARM, or bind option settings on | |
| accelerator-only tables..... | 259 |
| | |
| Notices..... | 265 |
| Trademarks..... | 266 |
| Terms and conditions for product documentation..... | 267 |
| | |
| GDPR considerations..... | 269 |
| GDPR..... | 269 |
| Why is GDPR important?..... | 269 |
| Product Configuration for GDPR..... | 270 |
| How to configure the offering so that it can be used in a GDPR environment..... | 270 |
| Data Life Cycle..... | 271 |
| What types of data?..... | 271 |
| Where in the process?..... | 271 |
| For what purpose?..... | 271 |
| Personal data used for online contact with IBM..... | 271 |
| Data Collection..... | 271 |
| Data Storage..... | 272 |
| Data Access..... | 272 |
| Data Processing..... | 272 |
| Data Deletion..... | 273 |
| Data Monitoring..... | 273 |
| Responding to Data Subject Rights..... | 273 |
| Does the offering facilitate being able to meet data subject rights?..... | 273 |
| | |
| Glossary..... | 275 |
| A..... | 275 |
| C..... | 275 |
| D..... | 275 |
| F..... | 276 |
| I..... | 276 |
| L..... | 276 |

| | |
|--------|-----|
| M..... | 276 |
| P..... | 276 |
| Q..... | 277 |
| R..... | 277 |
| S..... | 277 |
| T..... | 277 |
| V..... | 278 |
| W..... | 278 |

| | |
|-------------------|------------|
| Index..... | 279 |
|-------------------|------------|

Figures

- 1. Administration tasks in the overall process flow..... 5
- 2. Access plan graph of the query in the example..... 10
- 3. Possible table state transitions..... 15
- 4. IBM Db2 Analytics Accelerator setup..... 57
- 5. Administration Explorer..... 59
- 6. Object List Editor..... 60
- 7. Accelerator view for regular accelerators..... 64
- 8. Accelerator view for virtual accelerators..... 75
- 9. Welcome page of IBM Data Server Manager..... 77
- 10. Accelerator view in IBM Data Server Manager..... 79
- 11. The list of tables in IBM Data Server Manager..... 85
- 12. The list of queries in IBM Data Server Manager..... 89
- 13. Wait time, execution time, fetch time, and elapsed time in comparison..... 146
- 14. The System Utilization view of the accelerator monitoring window..... 166
- 15. The Current Tasks view of the accelerator monitoring window..... 167
- 16. The Finished Tasks view of the accelerator monitoring window..... 168
- 17. The Data Slices view of the accelerator monitoring window..... 169
- 18. The Incremental Updates view of the accelerator monitoring window..... 170
- 19. Federated access diagram..... 200
- 20. All members in the same LPAR..... 233
- 21. Members in two different LPARs..... 234
- 22. SQL code -430 message window..... 240

About this book

This book provides information about the following subjects:

- Connecting to a data server
- Adding query accelerators
- Adding and maintaining tables for query acceleration
- Configuring and activating system traces

Who should read this book

This book is intended for database administrators working with administration client applications to complete administration tasks for IBM DB2® Analytics Accelerator for z/OS.

The most important tasks in this context are the definition and deployment of data for accelerated database queries and the adding, removal, activation, and deactivation of individual accelerators within the system configuration.

What's new in version 5?

This version of IBM Db2 Analytics Accelerator for z/OS, when used with the latest Db2 for z/OS support, includes the following new features:

- Support for temporal Db2 tables (tables with system or business period definitions)
- Encryption of data in motion
- Option to integrate *IBM Netezza® Analytics* modeling and prediction algorithms
- Installation enhancements
- Improved backward compatibility. Stored procedures can now be at a higher level than accelerator software.

Enhancements in this version

For enhancements in this or previous follow-up versions, see the [What's new](#) document.

IBM Knowledge Center and book revision July 2016:

The suffixes of stored-procedure messages have been corrected. They now show the proper letters E, I, or W.

Accessibility features

Accessibility features help users who have a disability, such as restricted mobility or limited vision, to use information technology products successfully.

Accessibility features

The following list includes the major accessibility features in IBM Db2 Analytics Accelerator Studio:

- Keyboard-only operation
- Interfaces that are commonly used by screen readers

The IBM Db2 Analytics Accelerator for z/OS documentation in IBM Knowledge Center and its related publications are accessibility-enabled.

Keyboard navigation

In addition to the standard navigation keys of your operating system, this product uses keyboard shortcuts and controls of the Eclipse framework. For more information about these features:

1. Go to <https://www.eclipse.org/documentation/>.
2. Open the information center of one of the recent Eclipse releases, such as <https://help.eclipse.org/2019-12/index.jsp>.
3. Search for the article *Navigating the user interface using the keyboard*.

Interface information

The Eclipse framework supports the JAWS screen reader software. If you are facing difficulties in getting JAWS to read out table column headers, see the following articles in a recent Eclipse information center:

- *Accessibility features in textual editors*
- *Tips for making user interfaces accessible*

How to access these articles is described under [“Keyboard navigation”](#) on page xvii.

IBM and accessibility

See the [IBM Human Ability and Accessibility Center](#) for more information about the commitment that IBM has to accessibility.

Chapter 1. Introduction

IBM Db2 Analytics Accelerator for z/OS is a query accelerator capable of reducing response times for Db2 for z/OS queries by an order of magnitude.

IBM Db2 Analytics Accelerator for z/OS integrates deeply into your existing Db2 for z/OS environment and can process very large amounts of data. The addition of IBM Db2 Analytics Accelerator for z/OS makes Db2 for z/OS a truly universal database management system with optimum performance characteristics for transactional and analytical applications.

You can use the following graphical front-ends or administration clients to administer IBM Db2 Analytics Accelerator for z/OS:

- IBM Db2 Analytics Accelerator Studio
- IBM Data Server Manager

These client applications offer functions for the configuration and administration, as well as analytical tools that collect performance metrics or troubleshooting information.

This chapter provides an overview of the basic tasks that can be completed with either administration client.

Connecting to a data server

IBM Db2 Analytics Accelerator for z/OS needs access to your data servers to read the database catalogs and invoke the stored procedures for the accelerators. To connect to a database server, you must complete the tasks that are described in this section.

Related tasks

[Connecting to a database server](#)

The steps to connect to a Db2 subsystem differ with respect to the administration client that you use.

Database connection profiles

Your administration client connects to your Db2 for z/OS data server using Java™ Database Connectivity (JDBC), like other database clients. The configuration parameters for accessing a Db2 for z/OS data server are stored in database connection profiles. Create a database connection profile for each Db2 for z/OS data server with an accelerator.

Related tasks

[Creating a database connection profile](#)

Create a database connection profile to gain access to a Db2 subsystem on a database server. A Db2 subsystem houses one or more databases, in which the source data for query acceleration (schemas and tables) is kept.

Connecting to a database

You can easily connect to a database (called Db2 subsystem in Db2 for z/OS) from your administration client.

Adding accelerators

When a connection to a Db2 subsystem has been established through one of your database connection profiles, you can see all currently deployed accelerators.

In IBM Db2 Analytics Accelerator Studio, the accelerators are listed in the **Object List Editor**. You access the Object List Editor from the **Accelerator Perspective** in IBM Db2 Analytics Accelerator Studio.

In IBM Data Server Manager, the accelerators are listed in the **Accelerator** view, which is accessible from the ADMINISTER submenu of the main menu.

To connect a newly installed accelerator, use the **Add Accelerator** wizard, which is available in either administration client.

Related tasks

[Completing the authentication using the Add Accelerator wizard](#)

To complete the authentication, you specify the IP address, the port number, and the pairing code in the **Add Accelerator** wizard.

Defining the data to load into an accelerator

Defining the data to load into an accelerator basically means selecting the proper tables and choosing favorable distribution keys and organizing keys. However, you also need to complete a number of related sub-tasks. This section lists all required tasks in the correct order.

Selecting the proper tables

In choosing the proper tables, you determine the data to be queried. For each Db2 for z/OS table that you select, a corresponding table is created on one or more accelerators. These tables are called accelerator-shadow tables. Accelerator-shadow tables are not necessarily copies of their originals. Often, they contain fewer columns than the tables they stem from because columns with unsupported data types are excluded. Accelerator-shadow tables must be filled with data before they can be queried. This is done in a later step (see loading accelerator-shadow tables).

Related tasks

[Defining tables on an accelerator](#)

Using the **Add Tables to Accelerator** or the **Select Tables to Add** wizard, you can define accelerator-shadow tables on an accelerator.

Checking the table size

When you select a table for an accelerator in the **Add Tables** wizard, your administration client displays the table size. This table size is calculated on the basis of the values in the CARDF and AVGROWLEN columns of the SYSIBM.SYSTABLES table. Thus the metrics come from Db2 for z/OS. Comparing this size with the available disk space on your accelerator, you can roughly assess how much space the table will occupy on your accelerator. However, Db2 for z/OS and the accelerator use completely different compression algorithms, so the size of a table in Db2 might differ from the size of the same table on the accelerator.

Choosing a distribution key

By default, all rows in accelerator-shadow tables are evenly distributed among the existing worker nodes (random distribution). When a query includes table joins, it can be that a join can only be executed if table rows are sent from one worker node to another (redistribution), or that all rows are first sent to the Netezza host to be distributed to the worker nodes from there (broadcast). Both, redistribution and broadcast, can be very time-consuming when big tables with millions or even billions of records are involved, to the extent that the accelerator becomes ineffective.

Using distribution keys, you can instruct IBM Db2 Analytics Accelerator for z/OS to distribute the rows of tables to be joined to the same worker node so that redistributions and broadcasts of large amounts of data can be avoided.

Related concepts

[Distribution keys](#)

You can choose between two methods to distribute table rows to the worker nodes of your accelerator: random distribution and distribution using a distribution key.

[How to select tables for query acceleration](#)

Selecting the proper tables for a query to be accelerated is basically simple: You need to define the tables that are referenced by the query. Slightly more thought needs to be spent on the choice of proper distribution keys and organizing keys.

Related tasks

[Specifying or changing a distribution key or organizing keys](#)

Distribution and organizing keys have a considerable impact on the query response time.

Choosing an organizing key

Organizing keys can speed up accelerated queries even further as they diminish the time that is needed to scan the disks belonging to a single worker node.

When you create an organizing key, you select certain columns to the effect that rows of accelerator-shadow tables with equal and nearby values in the selected columns are grouped together. These clusters are then written to the extents, that is, addressable storage blocks on disk.

IBM Db2 Analytics Accelerator for z/OS creates zone maps for each column that is selected as an organizing key. Zone maps contain information about the value range (minimum and maximum) that can be found in an extent.

When an incoming query restricts on a column that was selected as an organizing key, IBM Db2 Analytics Accelerator for z/OS first uses the information in the zone maps to identify the extents that contain accelerator-shadow table rows with relevant data. When an extent must be scanned, the query engine benefits from the fact that the table rows are organized in clusters. If a table row is found with a column value that is not relevant to the query, this and all remaining rows in the cluster (rows with the same value in that column) can be skipped. Only blocks with relevant table rows must be read line-by-line, which can reduce the time needed for disk and table scans dramatically.

Related concepts

Organizing keys

Organizing key also have an impact on the query response time. When choosing an organizing key, you select columns by means of which you group the rows of an accelerator-shadow table within the data slices on the worker nodes. This creates grouped segments or blocks of rows with equal or nearby values in the columns selected as organizing keys. If an incoming SQL query references one of the organizing key columns in a range or equality predicate, the query can run much faster because entire blocks can be skipped. It is not necessary to scan the entire accelerator-shadow table. Thus the time needed for disk output operations related to the query is drastically reduced.

Zone maps

Zone maps are automatically generated, internal tables that summarize the range of column values (minimum and maximum) of rows that fall into the same extent, that is, an addressable storage block on disk.

How to select tables for query acceleration

Selecting the proper tables for a query to be accelerated is basically simple: You need to define the tables that are referenced by the query. Slightly more thought needs to be spent on the choice of proper distribution keys and organizing keys.

Related tasks

[Specifying or changing a distribution key or organizing keys](#)

Distribution and organizing keys have a considerable impact on the query response time.

Working with accelerator-shadow tables

To populate, maintain, and control accelerator-shadow tables, you complete the tasks that are described here.

Loading data into selected tables

To enable users to run accelerated queries against selected database tables, you must load the empty tables that you previously added to the accelerator with data. In doing so, you create a snapshot copy of your existing Db2 for z/OS data on the accelerator.

The Db2 Optimizer calculates the expected response times for incoming queries. If an accelerator can process a query against the selected tables faster than the database management system, the query is routed to the accelerator and evaluated against the populated accelerator-shadow tables.

You can reload accelerator-shadow tables, and, under certain conditions, also reload selected partitions of such tables. Doing so replaces the current data with a more recent snapshot, resulting in an update. When you reload tables or partitions, the accelerator automatically detects the tables and partitions that changed since the last load. This way, you can avoid loading the same data twice. The load wizard shows the load status for each table or partition and recommends maintenance activities.

Furthermore, you can enable incremental updates. Once this ongoing process is enabled, changes to the original Db2 data tables are detected, captured, and propagated automatically to the corresponding accelerator-shadow tables.

Related concepts

Updating accelerator tables continually

The incremental update function of IBM Db2 Analytics Accelerator for z/OS allows you to update accelerator-shadow tables continually. Changes to the data in original Db2 for z/OS tables are thus propagated to the corresponding target tables with a high frequency and just a brief delay. This way, query results from an accelerator are always extracted from recent, close-to-real-time data.

Related tasks

Loading tables

Successful queries against accelerator-shadow tables are possible only if the tables contain data. Therefore, you must load the tables after their definition (empty structure) has been copied to the accelerator.

Enabling tables for query acceleration

Query acceleration can be switched on and off for each accelerator-shadow table. This allows you to do maintenance work on a particular table while query acceleration remains active for other tables on the same accelerator.

Disabling query acceleration for a table

Disabling a table, you can prevent accelerated queries against this table. This might be necessary when a query must be run against very recent data, which has not yet been copied to the accelerator.

Enabling tables for incremental updates

The incremental update function allows you to automatically update accelerator-shadow tables in an ongoing process. Updates to Db2 tables are then propagated to the corresponding tables on the

accelerator with little delay, so that accelerated queries will always “hit” very recent data. You have to mark the tables that you want to include in this process.

Disabling incremental updates

Disabling incremental updates excludes tables from the incremental update process.

Moving partition or table data to an accelerator

If table partitions in Db2 for z/OS contain data that is no longer updated (historical data), you can use High Performance Storage Saver to move this data to an accelerator to free up costly storage on your Db2 for z/OS data server. A positive side-effect is that query processing and table maintenance become faster because the remaining data consists of fewer table rows and indexes require fewer entries.

Removing tables

If tables are no longer needed for queries, you can use the removal function in your administration client to remove the accelerator-shadow tables from the accelerator.

Related tasks

[Removing tables from an accelerator](#)

Follow the steps in this topic to remove accelerator-shadow tables from an accelerator.

Order in which to complete tasks

See a diagram that shows the order of the most common tasks.

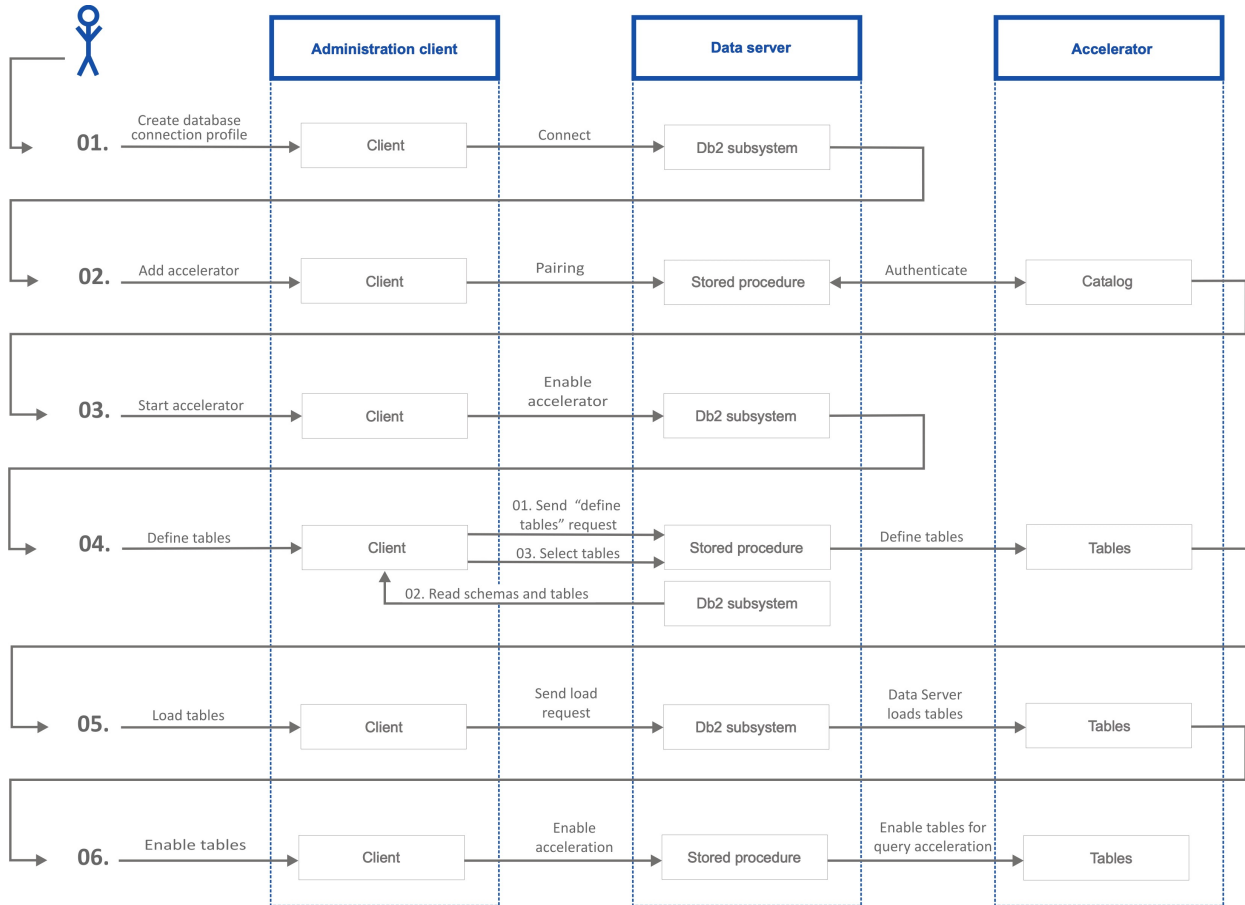

Figure 1. Administration tasks in the overall process flow

Chapter 2. Basic concepts

Get familiar with the basic concepts of IBM Db2 Analytics Accelerator for z/OS.

Accelerator

IBM Db2 Analytics Accelerator for z/OS consists of a high-performance hardware platform and an optimized database query engine. These components work together to support a variety of data analysis and business reporting tasks.

The high-performance query processing capabilities are embedded in a “shared nothing” architecture, which means that each worker node is able to process data independently, without network traffic or communication between the nodes. Hence there is hardly a contention for shared resources.

Each query is processed in parallel by all worker nodes, with each node processing a portion of each accelerator-shadow table. These portions are called *data slices*. The accelerator-shadow tables are thus horizontally partitioned because each worker node processes a data slice of each table.

Virtual accelerator

For testing purposes, you can employ virtual accelerators. These are simulators that use the EXPLAIN function offered by Db2 for z/OS. The output will always be Db2 EXPLAIN information because virtual accelerators cannot process regular queries and hence cannot return the corresponding results.

The EXPLAIN information can be visualized in an access plan graph (Visual Explain Graph). While the same information can also be obtained from real accelerators, virtual accelerators have the advantage that they do not require accelerator hardware. You can thus check whether queries can be accelerated, see if queries contain errors, and calculate response time estimates without making extra demands on the hardware resources.

Related concepts

EXPLAIN information

After creating the necessary EXPLAIN tables, you can analyze queries by invoking the Db2 EXPLAIN function. Such queries are accepted by regular and virtual accelerators alike. The analysis shows whether a query can be accelerated, indicates the reason for a failure, and gives a response time estimate. The outcome of the analysis can also be visualized in an access plan graph.

Related tasks

Displaying an access plan graph

An access plan graph is a visual representation of a query that shows the database objects that are accessed by the query and the order in which this is done.

Static SQL query support

Static SQL query support means that you can now accelerate SQL queries that are embedded within Db2 for z/OS application programs. Older versions of IBM Db2 Analytics Accelerator for z/OS could not accelerate such queries.

Static SQL queries are prepared at the time the application program is bound as a package in Db2 for z/OS, that is, before the execution of the application in Db2. To accelerate static SQL queries within these application programs, you must BIND or REBIND the Db2 package for that application and specify a new bind option that requests static query acceleration.

Related tasks

Preparing tables for workload balancing and accelerating static SQL queries

You need not enable workload balancing or static SQL support. However, the development of these features made it necessary to introduce a new naming scheme for tables. So if you have accelerator-shadow tables that were defined with older versions of IBM Db2 Analytics Accelerator for z/OS and want

to use workload balancing or accelerate static SQL queries, you must either migrate, or, if this is not possible, remove and then redefine those tables.

Accelerator-shadow table

An accelerator-shadow table represents a table in a Db2 subsystem. When you define accelerator-shadow tables in your administration client, you instruct IBM Db2 Analytics Accelerator for z/OS to copy the definition of that table (an empty table) to an accelerator.

Queries including this table are then routed to the accelerator provided that the requirements for query redirection are met. A query can only be routed to an accelerator if the query refers to a subset or all of the tables on the accelerator.

Restriction: A table can be added to multiple accelerators, but an accelerated query using that table can run only on one accelerator at a time.

In addition, a query can only be accelerated if all tables that are referenced by the query reside on the same accelerator, if the accelerator-shadow tables are loaded, and if query acceleration is enabled for these tables. A query can reference tables indirectly if the table references a view or a table alias. For example, if the query references a view that joins two tables, both tables must be present on the accelerator.

When tables are added to an accelerator, Db2 for z/OS keeps track of these accelerator-shadow tables in its system catalog. The system table entries enable the optimizer of the database management system to complete the following tasks:

- Query matching, that is, comparing an incoming query with the information stored in the system tables to check whether the query can be handled by IBM Db2 Analytics Accelerator for z/OS.
- Query evaluation, that is, calculating the estimated query response time. If a performance gain can be predicted, the query is sent to IBM Db2 Analytics Accelerator for z/OS. If not, the query is handled by the database management system itself.

If a table contains columns with unsupported data types, these columns will not be included in the corresponding accelerator-shadow table. All other columns will be copied. So the job of defining a table will be completed even if some columns do not fulfill the criteria. However, queries that address columns with unsupported data types will not be accelerated.

Related tasks

Defining tables on an accelerator

Using the **Add Tables to Accelerator** or the **Select Tables to Add** wizard, you can define accelerator-shadow tables on an accelerator.

How to select tables for query acceleration

Selecting the proper tables for a query to be accelerated is basically simple: You need to define the tables that are referenced by the query. Slightly more thought needs to be spent on the choice of proper distribution keys and organizing keys.

Suppose that you want to accelerate the following query, which extracts the total number of items and the total amount of money paid by each customer from a set of sales tables. The query does not reach infinitely into the past; rather, it considers just the orders that were received after a certain date. The results will be grouped by customer number.

Note: The O_TOTALPRICE column denotes the total price per order. It is not the total price that is calculated by the query.

Query:

```
SELECT SUM(L_QUANTITY), SUM(O_TOTALPRICE), O_CUSTKEY
FROM TPCH.LINEITEM L JOIN TPCH.ORDERS O ON L.L_ORDERKEY = O.O_ORDERKEY
WHERE O.O_ORDERDATE > '01.01.1994' GROUP BY O.O_CUSTKEY;
```

The query references the following tables:

- LINEITEM (L)
- ORDERS (O)

You would thus define these tables on the accelerator.

The query contains the following join predicate (join condition):

```
L.L_ORDERKEY = O.O_ORDERKEY
```

Suppose that O.O_ORDERKEY is a primary key and that the L table uses this key as a foreign key (L.L_ORDERKEY). To enable colocated joins, which lead to shorter query response times, the columns of accelerator-shadow tables must be on the same processing node. In order to achieve this, you would thus use O.O_ORDERKEY and L.L_ORDERKEY as distribution keys. Hence you would specify O.O_ORDERKEY as the distribution key for O and L.L_ORDERKEY as the distribution key for L.

Furthermore, the query contains the condition

```
WHERE O.O_ORDERDATE > '01.01.1994'
```

The O.O_ORDERDATE column makes a good candidate for an organizing key because its selection as a key of this type will group table rows with the same shipment date together. All rows with the same shipment date will be organized in blocks or clusters. When the query “encounters” a value that does not fulfill the condition, it can skip an entire block rather than individual rows. This decreases the time that is needed for scans of accelerator-shadow tables, and thus further decreases the query response time.

Access plan graph

If you are unsure whether the query refers to views or aliases rather than actual tables, you can display the access plan graph of the query.

In the access plan graph for this example, you can see that TPCH.LINEITEM and TPCH.ORDERS are tables because they appear in the access plan graph. Views and aliases are not represented in access plan graphs. See [Figure 2 on page 10](#).

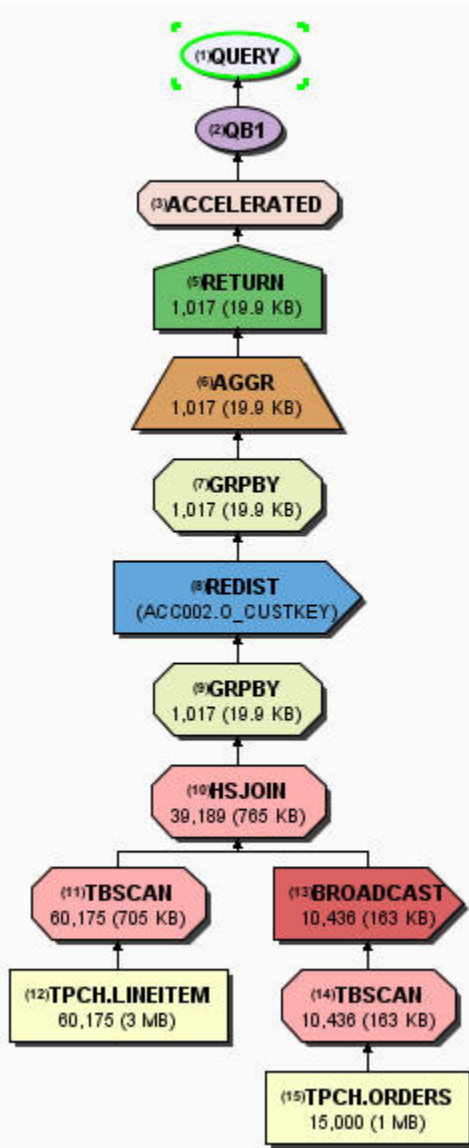

Figure 2. Access plan graph of the query in the example

Related concepts

Choosing a distribution key

By default, all rows in accelerator-shadow tables are evenly distributed among the existing worker nodes (random distribution). When a query includes table joins, it can be that a join can only be executed if table rows are sent from one worker node to another (redistribution), or that all rows are first sent to the Netezza host to be distributed to the worker nodes from there (broadcast). Both, redistribution and broadcast, can be very time-consuming when big tables with millions or even billions of records are involved, to the extent that the accelerator becomes ineffective.

Choosing an organizing key

Organizing keys can speed up accelerated queries even further as they diminish the time that is needed to scan the disks belonging to a single worker node.

Related tasks

Displaying an access plan graph

An access plan graph is a visual representation of a query that shows the database objects that are accessed by the query and the order in which this is done.

Related reference

[Types of access plan graphs and nodes in these graphs](#)

Different graphs are displayed for queries that can be accelerated and queries that cannot be accelerated. Read a brief article on how these graphs differ, and which set of nodes you can expect in either of these.

Distribution keys

You can choose between two methods to distribute table rows to the worker nodes of your accelerator: random distribution and distribution using a distribution key.

Random distribution

A circular or revolving distribution of the rows in an accelerator-shadow table. Each data slice, which is the portion of data that is processed by a single worker node, is assigned an equal number of table rows starting with the first slice, then moving on to the next, and so on. After table rows have been assigned to the last unit in the chain, the next chunk of rows is distributed to the first again. This process continues until all table rows have been distributed.

Use of a distribution key (hash partitioning)

You can specify up to four columns that make up a distribution key. The accelerator uses a hash function on the key columns to determine the data slice or worker node that receives a table row. Rows with equal hash values are distributed to the same worker node.

By default, random distribution is used to distribute table rows to worker nodes for query processing. That is, all tables are evenly distributed among the existing worker nodes.

Impact of the distribution key on the query performance

Parallel processing works best if the table rows to be processed are evenly distributed across the worker nodes. If the rows of a table that is referenced by a query are unevenly distributed, the worker nodes with fewer rows have to wait for the node with the biggest number of rows to finish processing. However, if your queries involve joins of big tables (100 million to billions of rows), and the rows of these accelerator-shadow tables are scattered across the worker nodes even though they are evenly distributed in terms of quantity, you can easily spend much more time on data redistributions and broadcasts than you actually gain by the advantage of an even distribution.

Impact of distribution key on join performance

When two tables are joined, the query runs fastest if the matched rows of both accelerator-shadow tables reside on the same worker node (colocated join). You can instigate colocated joins by selecting the join columns as the distribution key for both tables.

However, if an accelerator-shadow table *F1* is joined with two or more other tables *D1*, ... *Dn* using different join keys, you can only locate one of the pairs (*F1-D1*, *F1-D2*, ..., *F1-Dn*) on the same node because you can only select one of the join columns in table *F1* as the distribution key for *F1*. In this case, it is best to colocate the biggest tables.

Best practices for selecting distribution keys

Follow these guidelines when using distribution keys:

- For fact tables and the largest dimension tables, specify a distribution key. For all other tables, start with the default (random distribution).
- Prefer single-column distribution keys to multiple-column keys.
- Select a column as the distribution key that distributes the table rows as evenly as possible across the worker nodes, that is, select primary keys or columns with a unique index. Do not specify columns that only have a small number of distinct values. For example, Boolean values like *male* and *female* would place the table rows on two of the worker nodes only.
- When joining two large tables, try to colocate the tables by specifying the join columns as the distribution key for both tables. Note that to instigate a colocated join, the data types of the join columns in both tables must match.
- In general, do not specify a date, time, or timestamp column as the distribution key. Such keys would also distribute the table rows evenly across the worker nodes, but many queries restrict the number

of result rows by a range predicate on the date, time, or timestamp column. For example, a query retrieving revenue figures from last month only would be processed on a single worker node if a column MONTH was selected as the distribution key because rows with equal values in this column would all be assigned to the same data slice.

- Although adverse to the goal of faster query acceleration, a distribution key on the primary key or unique constraint of a table helps if you must update tables continually. Therefore, decide what is more important to you: query performance or the latency of incremental updates. The accelerator automatically picks a distribution key when you enable incremental updates for a table unless you have defined a distribution key by yourself.

Organizing keys

Organizing key also have an impact on the query response time. When choosing an organizing key, you select columns by means of which you group the rows of an accelerator-shadow table within the data slices on the worker nodes. This creates grouped segments or blocks of rows with equal or nearby values in the columns selected as organizing keys. If an incoming SQL query references one of the organizing key columns in a range or equality predicate, the query can run much faster because entire blocks can be skipped. It is not necessary to scan the entire accelerator-shadow table. Thus the time needed for disk output operations related to the query is drastically reduced.

Organizing keys allow the query engine to identify the disk regions (addressable storage blocks on the disk) that contain the clusters of rows relevant to a query.

Best practices for selecting organizing keys

- In general, the accelerator should be able to process your queries with adequate performance so that organizing keys are not needed. However, the use of an organizing key, particularly on large fact tables can result in table scan performance gains by multiple orders of magnitude.
- An organizing key has no effect if the table is too small. The **Organized** column in the **Accelerator** view reflects this by not showing a value for the degree of organization (percentage).
- It is recommended to define an organizing key for accelerator-shadow tables that you want to update continually by using the incremental update function. Use the primary key columns of the table for the organizing key. When the incremental update function applies DELETE or UPDATE statements, the accelerator has to search for the rows that must be deleted or updated. Defining an organizing key accelerates these operations.
- Organizing keys work best on large tables (with millions or more records), under the condition that your queries restrict on column values that are rather scattered across the table. For example, if a query restricts on a set of product IDs and customer IDs from a table of sales records in which the records are presorted by the date on which a record was added, the customer ID column and the product ID column would make good candidates for an organizing key. These keys would have the effect that records with the same customer ID and product ID are grouped together, leading to the table scan performance benefits described earlier.

Since restrictions on summary columns in dimension tables are, in many cases, automatically pushed down to the join column of a fact table, organizing keys on such columns in the fact table can be very beneficial.

An organizing key is also recommended if your history of data records reaches back into the past for an extended period, but the majority of your queries, in using a range predicate on a fact-table timestamp column or a parent attribute in a joined dimension, requires a constrained range of dates.

Example:

```
SELECT ... FROM ... WHERE TRANSACTION_DATE BETWEEN (<date1>, <date2>)
```

In this example, the TRANSACTION_DATE column would make a good organizing key.

As additional columns are chosen as organizing keys, the benefit of predicates on column subsets is reduced. Four keys are the allowed maximum. However, there is hardly a need to select more than three.

- Organizing keys are also useful the more frequently the columns that you specified as keys are used in query predicates, alone or in combination, and if the column cardinality is high (that is, if the columns have many different values).
- For organizing keys to have a positive effect on the table-scan performance, a query does not have to reference all the columns that have been defined as organizing keys. It is enough if just one of these columns is addressed in a query predicate. However, the benefit is higher if all columns are used because this means that the relevant rows are kept in a smaller number of disk regions.
- There is no preference for any of the columns that you specify and the order in which columns are selected does not matter either.
- Bear in mind, though, that clustered table rows cause a processing overhead when you load or update these tables on the accelerator.

Zone maps

Zone maps are automatically generated, internal tables that summarize the range of column values (minimum and maximum) of rows that fall into the same extent, that is, an addressable storage block on disk.

Zone maps are always created for columns that were selected as organizing keys. Furthermore, you can only select a column as an organizing key if the data type of this column allows IBM Db2 Analytics Accelerator for z/OS to create a zone map.

Using the information in the zone maps, IBM Db2 Analytics Accelerator for z/OS “knows” which extents it needs to “look at” during a disk scan. Extents with relevant data (table rows containing the values demanded by a query) must be scanned; those that contain just irrelevant data can be skipped.

Zone maps thus tell the query engine whether it is worth to look at a certain extent on disk. If it is, then the clusters within an extent allow the query engine to scan the table rows in the extent much faster because rows with relevant data will be found in the same block, while blocks that do not contain relevant data can be skipped entirely.

Tables states

A table can go through various states while it is being processed by IBM Db2 Analytics Accelerator for z/OS. The meaning of these states is explained here. In addition, it is shown which operation you can run on a table in a particular state. Finally, a diagram shows the possible shifts from one state to another (state transitions).

Table states are displayed in your administration client, in the **Last Load** column. In IBM Db2 Analytics Accelerator Studio, you find this column in the **Accelerator** view for regular accelerators (**Tables** section). In IBM Data Server Manager, the column is in the list of tables. A table can be in one of the following states:

InitialLoadPending

State after the definition of an accelerator-shadow table on the accelerator, which indicates that the table must be loaded with data.

InitialLoadInProgress

State that indicates the loading of an empty accelerator-shadow table or the reloading of an accelerator-shadow table that was in the *Error* state.

Loaded

The load process has been finished.

SchemaModificationInProgress

The schema of a table is being modified. This happens when you change distribution key or organizing key columns, or if background jobs create foreign-key relationships with columns of the table. A table

is also in this state when you run a synchronization job on an accelerator-shadow table because columns have been added to an original Db2 for z/OS table.

UpdateInProgress

The data of the table is being updated. For example, an accelerator-shadow table is in this state if a reload has been enforced by various circumstances.

ReplicationInProgress

The table data is currently being synchronized by the incremental update function.

ArchivingInProgress

Original Db2 table data (partitions) is being archived on an accelerator.

Error

State that indicates a processing error, after which an accelerator-shadow table is reset to the *InitialLoadPending* state. That is, a reload is required.

Possible operations

Table 1 on page 14 shows which operations you can run on a table in a particular state.

| <i>Table 1. Possible operations on a table depending on its state</i> | | | | | | |
|---|---|--|----------------------------|--|---|---------------|
| Table state | Enable or disable query acceleration | Load or update | Schema modification | Enable or disable incremental updates | Archive or restore partition data (High Performance Storage Saver) | Remove |
| <i>InitialLoadPending</i> | No | Yes. The entire accelerator-shadow table is loaded or reloaded. Partition lists are ignored. | Yes | Yes | No | Yes |
| <i>InitialLoadInProgress</i> | No | No | No | No | No | Yes |
| <i>Loaded</i> | Yes | Yes | Yes | Yes | Yes | Yes |
| <i>SchemaModificationInProgress</i> | Yes | No | No | No | No | Yes |
| <i>UpdateInProgress</i> | Yes | No | No | No | No | Yes |
| <i>ReplicationInProgress</i> | Yes | Yes | No | No | No | Yes |
| <i>ArchivingInProgress</i> | Yes | No | No | No | No | Yes |
| <i>Error</i> | No | Yes. The entire accelerator-shadow table is loaded or reloaded. Partition lists are ignored. | Yes | Yes | No | Yes |

State transitions

Figure 3 on page 15 shows the state transitions that are possible.

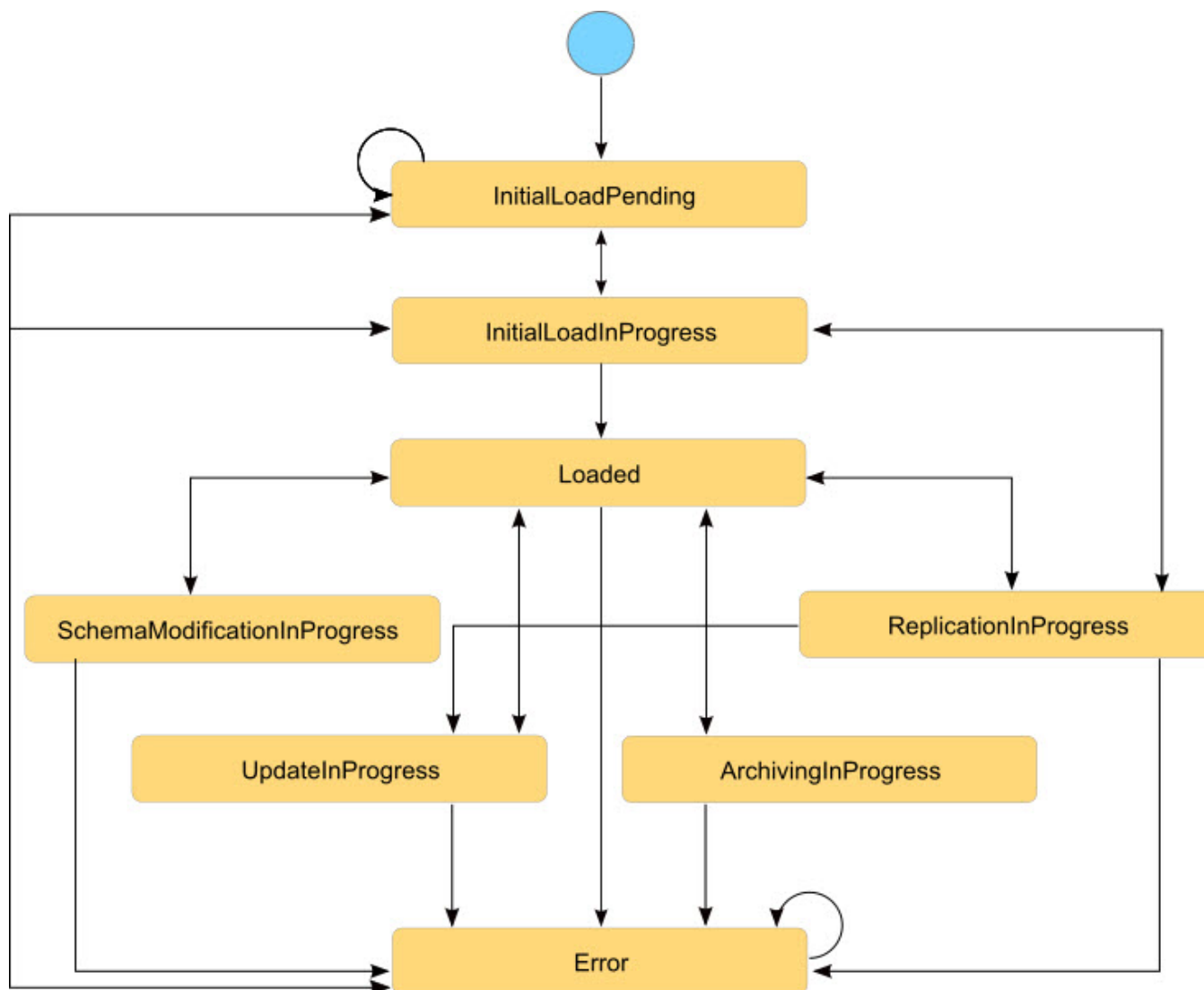

Figure 3. Possible table state transitions

Related concepts

[Accelerator view for regular accelerators](#)

Here is a brief description of the status information and the function buttons on the **Accelerator** view for regular accelerators.

[Accelerator view](#)

See a brief description of the status information and the function buttons on the **Accelerator** view of IBM Data Server Manager.

Accelerator-archive tables

These are table partitions or entire tables whose data was moved to an archive on an accelerator by the High-Performance Storage Saver. Moving table data saves storage space on IBM Z®.

You can move partitions or entire tables (all partitions of a table) to an archive on an accelerator if the tables were previously defined on the accelerator (that is, if accelerator-shadow tables of these tables exist). As part of the move, the original Db2 data is deleted. The table space containing the tables or

partitions in Db2 is set to a persistent (permanent) read-only state so that the original tables can no longer be updated or otherwise modified.

To be able to recover the data in an emergency case, an image copy is also created as part of the move. The recovery function of the High-Performance Storage Saver uses the image copies to restore the data to its original location in Db2. The High-Performance Storage Saver is used for historical data that is no longer actively used or maintained.

Normally, the data in accelerator-archive tables is not included in accelerated queries. However, you can set the parameter `GET_ACCEL_ARCHIVE = YES` to include it. This can be done at multiple levels: You can set `GET_ACCEL_ARCHIVE = YES` as a ZPARM, as a special register, as a bind option for static SQL, or as a connection property for Java Database Connectivity (JDBC) or Open Database Connectivity (ODBC) connections.

Mind that the `CURRENT_QUERY_ACCELERATION` special register must also be set, or otherwise the moved data cannot be accessed.

Related concepts

Freeing up storage in Db2 for z/OS

The High Performance Storage Saver archives data of table partitions in Db2 for z/OS to an accelerator. In moving data that is no longer actively used (historical data) to a less expensive storage device, you can free up costly storage space on your database server.

Accelerator-only tables and in-database transformation

Accelerator-only tables are tables that do not originate from Db2 base tables. Their data exists only on an accelerator. Data in accelerator-only tables can only be modified by data-manipulation (DML) statements (INSERT, UPDATE, and DELETE). With accelerator-only tables, you can do in-database transformation (IDT) in a more efficient way.

Queries and data-manipulation statements against accelerator-only tables are always routed to an accelerator. If a SQL statement does not satisfy the conditions for acceleration, the statement fails. Furthermore, DML statements that are run on an accelerator can only manipulate data in accelerator-only tables.

Accelerator-only tables are useful for statistics and analytic tools that employ temporary data for reports because the high velocity of execution allows these tools to gather all required data quickly. Since the data in these tables can be modified fast, they are also ideal for data-preparation tasks that must be completed before the data can be used for predictive modeling.

Use accelerator-only tables if you want to accelerate queries that access previously calculated, interim result sets. To take full advantage of the product's high-speed capabilities, store all your interim results in accelerator-only tables. This allows subsequent queries or data transformations to process all relevant data on the accelerator.

To create an accelerator-only table, you submit a `CREATE TABLE` statement in Db2 that uses the `IN ACCELERATOR <acceleratorname>` clause. Accelerator-only tables are registered in the Db2 catalog with a type of 'D'.

Accelerator-only tables cannot be loaded by the `SYSPROC.ACCEL_LOAD_TABLES` stored procedure or by the corresponding function in your administration client. You have to use `INSERT` statements. These can be submitted from interactive client interfaces (SPUFI, IBM Data Studio, RUN SQL submenu in IBM Data Server Manager), or from client application programs using ODBC, JDBC or static SQL. It is possible to transfer many rows in a single batch or transaction (multi-row insert). However, the multi-row insert support is limited to client application programs and cannot be used interactively.

Important:

The use of accelerator-only tables brings extra workloads to your accelerators that compete for the same resources, such as CPU, disk, and system memory. This might impact the stability of your production environment.

Conventional in-database transformation versus in-database transformation with accelerator-only tables

A conventional approach to in-database transformation might consist of the following steps:

1. CREATE TABLE T1 ...;
2. INSERT INTO T1 SELECT ... FROM T0 ...;
3. SELECT ... FROM T1 ...;
4. DROP TABLE T1;

Step “1” on page 17 creates an interim table. Interim results that were calculated on the basis of the data in T0 are stored in table T1 (see step “2” on page 17). In step “3” on page 17, a second query reads the interim table T1 to calculate the final result. In step “4” on page 17, the interim table T1 is dropped because it is no longer needed.

To accelerate the steps above, create table T1 in step “1” on page 17 as an accelerator-only table. This accelerates the final (second) query and avoids the movement of data in Db2, which occupies considerable processing resources if T1 is large. If T1 is an accelerator-only table, the INSERT statement in step “2” on page 17 is run on the accelerator rather than in Db2. You also omit the duplication of table T1 in Db2 because you do not need to run IBM Db2 Analytics Accelerator stored procedures to define, load, and enable table T1 on the accelerator. This is a big advantage because many extract-transform-and-load (ETL) tools that generate data transformation statements automatically do not support stored procedure calls. Using accelerator-only tables, you have to modify the statements generated by these tools only slightly to end up with accelerated in-database transformation steps that do not require stored procedure calls.

Before running the following modified steps, you must define, load and enable acceleration for table T0 on the accelerator by using the IBM Db2 Analytics Accelerator stored procedures or the corresponding functions in your administration client. This is just a one-time preparation step. Then you continue with the following steps:

1. CREATE TABLE Q1.T1 ... IN ACCELERATOR ... IN DATABASE ...;
2. INSERT INTO Q1.T1 SELECT ... FROM T0 ...;
3. SELECT ... FROM Q1.T1 ...;
4. DROP TABLE Q1.T1;

Notes:

1. Depending on your situation, you might want to keep the accelerator-only table for later use and run step “4” on page 17 at a later time.
2. In contrast to temporary tables, accelerator-only tables are much more like normal Db2 tables. It is therefore recommended that you create these tables in an authorized database by using a CREATE TABLE statement with the IN DATABASE clause. Otherwise, accelerator-only tables are created in an implicit database, just like normal Db2 tables. You might also want to add an explicit schema qualifier to the table name.

The following examples consist of extended data transformations that use more than one interim table. They show how to change conventional Db2 statements to arrive at an accelerated solution to in-database-transformation. The left column shows the conventional approach. The right column shows the in-database-transformation steps that include accelerator-only tables.

Example 1

The Db2 tables T1, T2 and T3 already exist. The conventional approach uses two declared global temporary tables to store the interim results.

Table 2. Example 1: Declared global temporary tables versus accelerator-only tables

| | Conventional approach (Db2) | Accelerator-only tables |
|----------------------|--|--|
| One-time preparation | N/A | Define and load the tables T1, T2 and T3 on accelerator ACCEL1 by using stored procedures or the corresponding functions in your administration client. |
| Step 2 | <pre> DECLARE GLOBAL TEMPORARY TABLE SESSION.TEMP1 (C11 CHAR(2), ...) ON COMMIT PRESERVE ROWS; INSERT INTO SESSION.TEMP1 SELECT ... FROM T1 ...; DECLARE GLOBAL TEMPORARY TABLE SESSION.TEMP2 (C21 CHAR(2), ...) ON COMMIT PRESERVE ROWS; INSERT INTO SESSION.TEMP2 SELECT ... FROM T2 ...; SELECT ... FROM FROM SESSION.TEMP1 ... SESSION.TEMP2 ... T3 ...; DROP TABLE SESSION.TEMP1; DROP TABLE SESSION.TEMP2; </pre> | <pre> SET CURRENT QUERY ACCELERATION = ALL; CREATE DATABASE DBTEMP; CREATE TABLE TEMP1 (C11 CHAR(2), ...) IN ACCELERATOR ACCEL1 IN DATABASE DBTEMP; INSERT INTO TEMP1 SELECT ... FROM T1 ...; CREATE TABLE TEMP2 (C21 CHAR(2), ...) IN ACCELERATOR ACCEL1 IN DATABASE DBTEMP; INSERT INTO TEMP2 SELECT ... FROM T2 ...; SELECT ... FROM FROM TEMP1 ... TEMP2 ... T3 ...; DROP TABLE TEMP1; DROP TABLE TEMP2; DROP DATABASE DBTEMP; </pre> |

Example 2

The Db2 tables T1 and T2 already exist. The final transformation result is stored in the existing Db2 table T3. The conventional approach uses two declared global temporary tables to store the interim transformation results.

Table 3. Example 2: Declared global temporary tables versus accelerator-only tables

| | Conventional approach (Db2) | Accelerator-only tables |
|----------------------|-----------------------------|---|
| One-time preparation | N/A | Define and load the tables T1 and T2 on accelerator ACCEL1 by using stored procedures or the corresponding functions in your administration client. |

Table 3. Example 2: Declared global temporary tables versus accelerator-only tables (continued)

| | Conventional approach (Db2) | Accelerator-only tables |
|--------|--|--|
| Step 2 | <pre> DECLARE GLOBAL TEMPORARY TABLE SESSION.TEMP1 (C11 CHAR(2), ...) ON COMMIT PRESERVE ROWS; INSERT INTO SESSION.TEMP1 SELECT ... FROM T1 ...; DECLARE GLOBAL TEMPORARY TABLE SESSION.TEMP2 (C21 CHAR(2), ...) ON COMMIT PRESERVE ROWS; INSERT INTO SESSION.TEMP2 SELECT ... FROM SESSION.TEMP1 ...; INSERT INTO T3 SELECT ... FROM FROM SESSION.TEMP2 ... T2 ...; DROP TABLE SESSION.TEMP1; DROP TABLE SESSION.TEMP2; </pre> | <pre> SET CURRENT QUERY ACCELERATION = ALL; CREATE DATABASE DBTEMP; CREATE TABLE TEMP1 (C11 CHAR(2), ...) IN ACCELERATOR ACCEL1 IN DATABASE DBTEMP; INSERT INTO TEMP1 SELECT ... FROM T1 ...; CREATE TABLE TEMP2 (C21 CHAR(2), ...) IN ACCELERATOR ACCEL1 IN DATABASE DBTEMP; INSERT INTO TEMP2 SELECT ... FROM TEMP1 ...; INSERT INTO T3 SELECT ... FROM FROM TEMP1 ... T2 ...; DROP TABLE TEMP1; DROP TABLE TEMP2; DROP DATABASE DBTEMP; </pre> |

Notes:

- Bear in mind that alternative constructs, such as declared global temporary tables, which can exist in Db2, but not on an accelerator, cannot be accelerated by IBM Db2 Analytics Accelerator.
- It is not possible to create image copies of accelerator-only tables because these tables do not hold any data in Db2. You can only recover the data from their original sources, which is why accelerator-only tables should be used only for temporary data.
- An accelerator-only table can reside on just a single accelerator. Copies on other accelerators cannot exist (no high availability).
- For information on how to create an accelerator-only table using the CREATE TABLE command or the restrictions governing the use of these tables, follow the **Related information** link at the end of this topic.
- When you submit a CREATE TABLE statement to create an accelerator-only table, the statement is committed in Db2 for z/OS before the corresponding action is completed on the accelerator. That is, there is a brief period during which the table is listed in the Db2 catalog, but not in the accelerator catalog. If you run the SYSPROC.ACCEL_GET_TABLES_INFO stored procedure during that time, the integrity status `ViolatedOnAccelerator` is reported for that table in the result set. (In IBM Db2 Analytics Accelerator Studio, you see the error icon next to the table name in the **Tables** section of the **Accelerator** view. In IBM Data Server Manager, you find a similar indicator. If you move the mouse pointer over the icon, the integrity status is displayed in a fly-over help window.)

Related concepts

[Configuring Db2 for z/OS for the acceleration of dynamic SQL queries](#)

To make Db2 for z/OS route dynamic SQL queries to an accelerator, you must enable acceleration by using the CURRENT QUERY ACCELERATION special register. Alternatively, you can set the QUERY_ACCELERATION ZPARM in Db2 for z/OS. This also applies to queries against accelerator-only tables.

[Configuring Db2 for z/OS for the acceleration of static SQL queries](#)

To accelerate static SQL queries, use the QUERYACCELERATION and GETACCELARCHIVE bind options for Db2 packages.

Related reference

[Restrictions of accelerator-only tables](#)

Here is a summary of the restrictions that exist for accelerator-only tables.

[Impact of special register, ZPARM, or bind option settings on accelerator-only tables](#)

SQL statements that reference accelerator-only tables can only be executed on an accelerator. However, certain combinations of special register and ZPARM settings might prohibit the execution of a statement on an accelerator. The same is true for the QUERYACCELERATION bind option for static SQL queries. The table in this section shows how these settings affect the statement execution.

Related information

[DB2 for z/OS 12: CREATE TABLE statement](#)

[DB2 for z/OS 12: INSERT statement](#)

[Batch size limit when using DB2 Universal JDBC Driver is 32K due to limitation of DRDA architecture](#)

Workload balancing

Workload balancing can be described as follows: If more than one accelerator is connected to a Db2 subsystem, and the tables that are referenced in a query are defined on multiple accelerators, IBM Db2 Analytics Accelerator for z/OS automatically picks the accelerator with the lowest utilization for processing.

Related tasks

[Preparing tables for workload balancing and accelerating static SQL queries](#)

You need not enable workload balancing or static SQL support. However, the development of these features made it necessary to introduce a new naming scheme for tables. So if you have accelerator-shadow tables that were defined with older versions of IBM Db2 Analytics Accelerator for z/OS and want to use workload balancing or accelerate static SQL queries, you must either migrate, or, if this is not possible, remove and then redefine those tables.

IBM Db2 Analytics Accelerator for z/OS system table entries

When you select tables for query acceleration, information about these tables is added to the IBM Db2 Analytics Accelerator for z/OS system tables in the Db2 for z/OS catalog of the connected subsystem. Each entry (system table row) serves as a link between Db2 and the table on the accelerator. An entry contains, among other information, the table name.

Chapter 3. Conditions for query routing to an accelerator

Queries can be routed to an accelerator only if certain conditions are met. There are also adverse conditions that prohibit query acceleration. Both types of conditions are discussed in this section.

A query can be routed to an accelerator if the following general conditions are met:

1. The accelerator is in an operational mode and has been started.
2. Db2 for z/OS has been configured so that the query will be routed to a connected accelerator provided that this query meets all other conditions.
3. The accelerator supports the SQL expressions that are used in the query.
4. All data that is referenced by the query, such as the contents of tables and views, is available on one and the same accelerator. To satisfy this condition, the accelerator must have been loaded with the data in question.

Related information

[DB2 10 for z/OS: SYSIBM.DSN_PROFILE_ATTRIBUTES](#)

[DB2 11 for z/OS: SYSIBM.DSN_PROFILE_ATTRIBUTES](#)

Configuring Db2 for z/OS for the acceleration of dynamic SQL queries

To make Db2 for z/OS route dynamic SQL queries to an accelerator, you must enable acceleration by using the CURRENT QUERY ACCELERATION special register. Alternatively, you can set the QUERY_ACCELERATION ZPARAM in Db2 for z/OS. This also applies to queries against accelerator-only tables.

The value of the QUERY_ACCELERATION ZPARAM provides the default setting for the CURRENT QUERY ACCELERATION special register. Both, the ZPARAM and the special register accept the following values:

1 (NONE)

No routing of dynamic SQL queries to an accelerator. Queries will be processed by Db2 for z/OS only (inhouse query processing).

2 (ENABLE)

A dynamic SQL query will be routed to an accelerator if it fulfills all required conditions. An incoming query is tested against a set of heuristics, which include the table size and a response time estimate based on cost information from the SYSIBM.DSN_PROFILE_ATTRIBUTES table. Both tests ensure that a query will only be routed to an accelerator if the query can be expected to run faster than in Db2 for z/OS. However, if an error occurs while the query is being processed by the accelerator, Db2 for z/OS will return a negative SQLCODE to the application and query processing will stop.

3 (ENABLE WITH FAILBACK)

Dynamic queries are accelerated only if Db2 for z/OS determines that it is advantageous to do so. If an accelerator returns an error during the PREPARE phase or when first opening (OPEN) the query, the query is processed by Db2 for z/OS rather than sent to the accelerator. If the accelerator returns an error during a FETCH operation or a subsequent OPEN operation, Db2 for z/OS returns an error to the user and the query ends abnormally.

4 (ELIGIBLE)

Dynamic queries are accelerated if they are eligible for acceleration. Db2 for z/OS does not use cost information to determine whether to accelerate the queries. Queries that are not eligible for acceleration are executed by Db2 for z/OS. If an accelerator fails while a query is running, or if the accelerator returns an error, Db2 for z/OS returns a negative SQL code to the application.

5 (ALL)

A dynamic query will always be routed to an accelerator, no matter if it fulfills the conditions or not. If processing cannot start or continue because an incoming query fails to fulfill all the conditions for accelerated query processing, Db2 for z/OS returns a negative SQLCODE to the application and query processing ends abruptly. That is, the query will not be processed at all.

Exceptions:

- If a dynamic query cannot be processed by IBM Db2 Analytics Accelerator because the tables do not exist on the accelerator, the query usually fails with an error message (-4742, reason code 12). However, such a query is processed by Db2 for z/OS if it references tables with the following qualifiers only:
 - SYSIBM
 - SYSACCEL
 - DB2GSE
 - SYSXSR
 - DGT
- Dynamic queries whose top query block is pruned, and which therefore return an empty result set, are processed by Db2 for z/OS. To check whether a query falls into this category, follow these steps:
 1. Explain the query using the DB2 EXPLAIN function. Use the following special register setting in the SQL statement:

```
SET CURRENT QUERY ACCELERATION = NONE
```

2. Check the PLAN_TABLE. If the top query block has been pruned, the entry for the query block shows PRUNED in the QBLOCK_TYPE column and no value in the ACCESTYPE column.

A query against an accelerator-only table can only succeed if the CURRENT QUERY ACCELERATION special register is set to a value other than NONE. There is no difference to accelerator-shadow tables in this respect. However, this does not affect data-definition (DDL) statements, such as CREATE TABLE or DROP TABLE. DDL statements are executed regardless of the special register or ZPRAM setting.

To enable query routing to an accelerator on the Db2 side, you issue the following SQL statement:

```
SET CURRENT QUERY ACCELERATION = ENABLE
```

FAILBACK processing

If you specify SET CURRENT QUERY ACCELERATION = ENABLE WITH FAILBACK, the query is returned to Db2 for processing if an error occurs during the PREPARE phase. This is the time before the query is actually routed to the accelerator, and during which the heuristics are tested. A query is also returned if an error was caused by an accelerator failure, a network failure, a network connection timeout, or a similar error. Errors immediately following the initial OPEN request of a query usually fall into this category.

Restrictions:

FAILBACK processes are not started if one of the following conditions applies:

- Query results have already been returned. This holds true even if the results are not complete.
- Query routing to an accelerator fails although the same query could be routed successfully before.
- Queries do not qualify for routing to an accelerator. Such queries are prepared and executed in Db2, regardless of the setting of the CURRENT QUERY ACCELERATION special register.

Settings resulting from the preparation phase are stored in the Db2 Dynamic Statement Cache. This allows the query engine to skip the preparation phase when a query comes in for the second time. However, this is also often the reason for not returning a query to Db2 for z/OS in case of an error. If you assume that this has happened, invalidate the Dynamic Statement Cache and rerun the query.

Configuring Db2 for z/OS for the acceleration of static SQL queries

To accelerate static SQL queries, use the QUERYACCELERATION and GETACCELARCHIVE bind options for Db2 packages.

Important:

- The new acceleration bind options apply to cursor queries and the SELECT portion of the SQL INSERT from SELECT statement. Since product version 4.1 PTF-3, the SQL SELECT INTO statement can also be bound for acceleration.
- The functions and behavior of these acceleration bind options for static queries are the same as the comparable existing acceleration special registers CURRENT QUERY ACCELERATION and CURRENT GET ACCEL ARCHIVE that are used for dynamic query acceleration, except that the Db2 decision to accelerate a static query and bind it for acceleration occurs at BIND or REBIND PACKAGE time, and not at query execution time when the application is run. The special registers do not affect the binding or the execution of static queries; instead, the new bind options are used to determine acceleration behavior for static queries.
- The accelerator need not be started at BIND or REBIND PACKAGE time for the static query to be bound for acceleration. However, you must start the accelerator before you run the application that executes the static query.
-

| <i>Table 4. Bind options for static SQL queries</i> | |
|--|---|
| QUERYACCELERATION | GETACCELARCHIVE |
| Binds static SQL queries for execution on an accelerator | Includes or excludes partition data that was archived by the High Performance Storage Saver from accelerated static SQL queries |

Table 4. Bind options for static SQL queries (continued)

| QUERYACCELERATION | GETACCELARCHIVE |
|--|---|
| <p>Settings:</p> <p>1 (NONE) No static query in the application is bound for acceleration or will be accelerated when the application is run.</p> <p>2 (ENABLE) A static query is bound for acceleration if it satisfies the acceleration criteria, including the cost and heuristics criteria. The query is routed to an accelerator when the application is run. If the static query does not satisfy the acceleration criteria, the query is bound for an execution in Db2.</p> <p>In the following cases, Db2 returns a negative SQL code for the query to the application:</p> <ul style="list-style-type: none"> • If a failure occurs while executing the accelerated static query on the accelerator • If the accelerator returns an error for the query • If the accelerator is not started and Db2 cannot route the static query to the accelerator for execution <p>3 (ENABLEWITHFAILBACK) Same as ENABLE, except for the following cases:</p> <ul style="list-style-type: none"> • The accelerator returns an error. • The accelerator fails on the first OPEN request for the accelerated static query. • The accelerator is not active or started when the first OPEN occurs. <p>In either of these cases, Db2 does not return a negative SQL code (accelerator failure) to the application, but executes a "failback" operation. That is, a temporary statement-level incremental bind of the query is performed, and the query is run in Db2. No "failback" to Db2 is possible after a successful OPEN request.</p> | <p>Settings:</p> <p>NO No static query is bound to retrieve archived partition data from the accelerator. If the static query is not bound for acceleration, it will be bound to run in Db2. If the static query is bound for acceleration because the bind option QUERYACCELERATION was specified, the query is routed to the accelerator when the application is run, but the query will only retrieve <i>active</i> data from the accelerator and ignore data archived by the High Performance Storage Saver.</p> <p>YES If the bind option QUERYACCELERATION is also specified and the static query references a table from which data has been archived by the High Performance Storage Saver, one of the following courses of action is taken:</p> <ul style="list-style-type: none"> • If the static query satisfies the acceleration criteria (as specified by QUERYACCELERATION), the query is bound for acceleration, and when the application is run, the query includes the archived data in the query. • If the static query cannot be bound for acceleration because it does not satisfy the criteria, Db2 fails to complete the BIND or REBIND PACKAGE operation and returns an error message for that query. |

Table 4. Bind options for static SQL queries (continued)

| QUERYACCELERATION | GETACCELARCHIVE |
|--|-----------------|
| <p>4 (ELIGIBLE) A static query is bound for acceleration if the query meets the basic acceleration criteria, regardless of cost or heuristics, and the query will be routed to the accelerator when the application is run.</p> <p>5 (ALL) All static queries in the application are to be bound for acceleration and routed to the accelerator when the application is run. If Db2 determines that a static query cannot be bound to run on the accelerator, and the query references a base table or view, Db2 fails to complete the BIND or REBIND PACKAGE operation with an error message for that query. No error message is returned for Declared Global Temp Tables (DGTs) and Created Global Temp Tables (CGTTs) because these tables cannot be accelerated.</p> | |

The new bind options are supported for:

- BIND, BIND COPY, and REBIND PACKAGE (local and remote)
- BIND DEPLOY (for SQLPL procedures)
- ALTER PROCEDURE and ALTER FUNCTION for native SQLPL procedures and SQLPL scalar functions
- CREATE PROCEDURE and CREATE FUNCTION for native SQLPL procedures and SQLPL scalar functions

The new bind options are not supported for:

- ALTER TRIGGER
- CREATE TRIGGER
- REBIND TRIGGER PACKAGE

Important:

- The default value for both new bind options is *option not specified*. The default for the bind options is not taken from the comparable Db2 installation system parameters (ZPARMs) QUERY_ACCELERATION and GET_ACCEL_ARCHIVE.
- If you submit a CREATE, DROP, or COMMIT statement against an accelerator-only table together with an INSERT, UPDATE, DELETE, or SELECT statement (against the same table) in the same thread, the table does not come into existence during the bind phase. However, the current implementation requires that all referenced tables are defined and enabled for query acceleration during the bind phase.

As a workaround, you can use the VALIDATE(RUN) bind option, which binds the INSERT, UPDATE, DELETE, or SELECT statement incrementally at execution time. However, this usually does not give you the optimum performance. Therefore, consider running the static CREATE statement in a separate thread before running the INSERT, UPDATE, DELETE, or SELECT statement.

The bind options can also be used for the acceleration of dynamic queries. If the bind options are specified, they set the initial values in the same manner as the comparable special registers CURRENT QUERY_ACCELERATION and CURRENT GET_ACCEL_ARCHIVE when the application is run, provided that the special registers have not already been set explicitly before the invocation of that application. The values of the bind options are then used as special register values for dynamic queries in that application, so that you do not have to add explicit SET statements to the application for the acceleration special registers.

Mind that you cannot use the bind options for dynamic queries under the following conditions:

- Dynamic and static queries are started from the same application or script.
- Both types of queries work on the same or share a number of tables.
- You want to accelerate the dynamic queries, but not the static queries.

In this case, you must use explicit SET statements to set the special registers in your application or script. This is because the bind options would also lead to an acceleration of the static queries. Special registers, on the other hand, have no effect on static queries.

The precedence order (low to high) for setting the initial value of the special registers is as follows:

1. Db2 installation system parameters QUERY_ACCELERATION and GET_ACCEL_ARCHIVE
2. Bind option value if specified (QUERYACCELERATION and GETACCELARCHIVE)
3. Explicit SET statement for the special register

As with the acceleration of dynamic queries and the use of the acceleration special registers, the use of the new bind options requires you to set ACCEL (Db2 ZPARM) to a value other than NONE to enable the Db2 subsystem for query routing to IBM Db2 Analytics Accelerator for z/OS.

Supported queries

A set of conditions must be fulfilled before an accelerator can handle a query.

The following conditions must apply:

- The principal expression used by the query is a SELECT statement or an “INSERT FROM SELECT” statement. In this case, only the SELECT part of the query is accelerated.

Note: To enable support for “INSERT FROM SELECT” statements, set the QUERY_ACCEL_OPTIONS parameter (a ZPARM) to the value 2. For more information, see *Installing Db2 libraries with IBM Db2 Analytics Accelerator for z/OS support* in the *IBM Db2 Analytics Accelerator for z/OS: Installation Guide*.

- The query is defined as read-only. The criteria for read-only queries are documented in the subsection *Read-only cursors* of the topic *DECLARE CURSOR* in the Db2 10 for z/OS information center or the IBM Knowledge Center. A link is provided under **Related information** at the end of this topic.

Tip: If a query is not considered a read-only query by Db2 for z/OS, but you want the query to run on an accelerator, you can add the FOR READ ONLY clause to the SQL of the query.

- If the query is submitted by an application and introduces a cursor definition by means of the DECLARE CURSOR statement, then this cursor must be a read-only cursor that is neither a scrollable cursor, nor a rowset cursor that is declared by a remote application, such as an SQL statement submitted from the Db2 CLI for Windows. However, read-only rowset cursors are supported if they are declared by local applications (such as SPUFI or local stored procedure calls) in the following contexts:

- As part of a DELCARE CURSOR statement, for example:

```
EXEC SQL DECLARE DYN1 CURSOR WITH ROWSET POSITIONING FOR STMT1;
```

- As an attribute in a PREPARE statement, for example:

```
STMTSTR = 'SELECT COLI2,COLI8,COLI4,COLI2'  
          || ' FROM NTZTB01'  
          || ' WHERE 1=1'  
          || ' ORDER BY COLI2'  
          || ' FOR FETCH ONLY';  
  
ATTRSTR = 'WITH ROWSET POSITIONING';  
  
EXEC SQL PREPARE STMT1 ATTRIBUTES :ATTRSTR FROM :STMTSTR;
```

- In a rowset-positioned FETCH operation, for example:

```
DCL AINT2A(07) BIN FIXED(15);  
DCL AINT2B(07) BIN FIXED(15);  
DCL AINT4B(07) BIN FIXED(31);
```

```
DCL AINT8B(07) BIN FIXED(63);

EXEC SQL FETCH NEXT ROWSET FROM DYN1 FOR :NROWS ROWS INTO
:AINT2A, :AINT8B, :AINT4B, :AINT2B;
```

- When `#SET MULT_FETCH` is used as an instruction for the DSNTEP4 program, for example:

```
//SYSIN DD *
--#SET MULT_FETCH 7
SET CURRENT_QUERY ACCELERATION = ALL;
SELECT COLI2, COLI8, COLI4, COLI2 FROM ADMF001.NTZTB01
WHERE 1=1 FOR FETCH ONLY;
```

- Plans for query processing must use packages rather than database request modules (DBRMs).
- Based on its own set of heuristics, Db2 classifies an acceleration of the query as favorable. That is, Db2 “expects” a much shorter query response time by routing the query to an accelerator.
- DRDA® is used for the transmission of the query from Db2 to the accelerator. Therefore, DRDA must be configured and started from any Db2 subsystem connected to the accelerator.

Related information

[DECLARE CURSOR](#)

Supported data types

See this overview of supported Db2 data types, corresponding Netezza types, ranges, and hints at restrictions. The section also lists the unsupported data types at the end.

Numeric data types

| Db2 type | Netezza type | Range Db2 | Range Netezza | Comment |
|----------|---------------------|--|---|--|
| SMALLINT | SMALLINT (INT2) | -32768 to +32767 | -32768 to +32767 | |
| INTEGER | INTEGER (INT, INT4) | -2147483648 to +2147483647 | -2147483648 to +2147483647 | |
| BIGINT | BIGINT (INT8) | -9223372036854 775808 to +9223372036854 775807 | -9223372036854 775808 to +9223372036854 775807 | |
| REAL | DOUBLE | ~ -7.2 * 10 ⁺⁷⁵ to -5.4 * 10 ⁻⁷⁹ or ~ +5.4 * 10 ⁻⁷⁹ to +7.2 * 10 ⁺⁷⁵ | DOUBLE on Netezza: ~ -1.79 * 10 ⁺³⁰⁸ to -3.40 * 10 ⁻³⁰⁸ or ~ +3.4 * 10 ⁻³⁰⁸ to +1.79 * 10 ⁺³⁰⁸ | For details, see “Differences in floating-point error tolerances” on page 56 |
| DOUBLE | DOUBLE | ~ -7.2 * 10 ⁺⁷⁵ to -5.4 * 10 ⁻⁷⁹ or ~ +5.4 * 10 ⁻⁷⁹ to +7.2 * 10 ⁺⁷⁵ | ~ -1.79 * 10 ⁺³⁰⁸ to -3.40 * 10 ⁻³⁰⁸ or ~ +3.4 * 10 ⁻³⁰⁸ to +1.79 * 10 ⁺³⁰⁸ | For details, see “Differences in floating-point error tolerances” on page 56 |

Table 5. Numeric data types (continued)

| Db2 type | Netezza type | Range Db2 | Range Netezza | Comment |
|--|--|-------------------|-------------------|---------|
| DECIMAL(<i>precision</i> , <i>scale</i>) | NUMERIC(<i>precision</i> , <i>scale</i>) | Max. precision 31 | Max. precision 38 | |

Date, time, and timestamp data types

Table 6. Date, time, and timestamp data types

| Db2 type | Netezza type | Range Db2 | Range Netezza | Comment |
|-----------|--------------|---|---|--|
| DATE | DATE | 0001-01-01 to 9999-12-31 | 0001-01-01 to 9999-12-31 | |
| TIME | TIME | 00:00:00.000000 to 24:00:00.000000 | 00:00:00 to 23:59:59 or 00:00:00 to 24:00:00 | The precision must be six fractional digits. You can set a ZPARM to truncate values with precision 12. See <i>Setting ZPARMs for IBM Db2 Analytics Accelerator in Db2 11 for z/OS</i> in the <i>IBM Db2 Analytics Accelerator for z/OS: Installation Guide</i> . |
| TIMESTAMP | TIMESTAMP | Date portion: 0001-01-01 to 9999-12-31 Time portion: 00:00:00.000000 to 24:00:00.000000 | Date portion: 0001-01-01 to 9999-12-31 Time portion: 00:00:00.000000 to 24:00:00.000000 or 00:00:00.000000 to 23:59:59.999999 | Timestamps with timezone specifications are not supported, to the effect that: <ul style="list-style-type: none"> • SQL queries that require TIMESTAMP with a timezone specification as the result data type are not routed to an accelerator. • Timestamps with timezone constants are not accepted. • Functions and special registers that are related to timestamps with timezone specifications are not accepted. |

String data types

Only the following combinations of coded character set identifiers (CCSID) and subtypes are allowed in string expressions:

| CCSID | Allowed character subtypes | Comment |
|--|--|--|
| ASCII (for example 819; there are numerous others) | SBCS | |
| EBCDIC (for example 37; there are numerous others) | SBCS MIXED (partially supported) DBCS (graphic, partially supported) | The combinations EBCDIC + MIXED and EBCDIC + DBCS are supported only if the system parameter QUERY_ACCEL_OPTIONS includes the value 1 and if the value in the SUPPORTLEVEL column of SYSACCEL.SYSACCELERATEDTABLES is 2 or higher for the affected tables. For more information about these options, see <i>Installing Db2 libraries with IBM Db2 Analytics Accelerator for z/OS support in the IBM Db2 Analytics Accelerator for z/OS: Installation Guide</i> |
| UNICODE (367, 1208, 1200) | SBCS (367) MIXED (1208) DBCS (1200) | |

| Db2 type | Netezza type | Supported CCSIDs | Comment |
|------------------------|--------------|--|---------|
| CHAR FOR SBCS DATA | CHAR | ASCII EBCDIC UNICODE (367) | |
| VARCHAR FOR SBCS DATA | VARCHAR | ASCII EBCDIC UNICODE (367) | |
| CHAR FOR MIXED DATA | NVARCHAR | UNICODE (1208) EBCDIC (partially supported) | |
| VARCHAR FOR MIXED DATA | NVARCHAR | UNICODE (1208) EBCDIC (partially supported) | |

Table 8. String data types (continued)

| Db2 type | Netezza type | Supported CCSIDs | Comment |
|----------------------|--------------|--|--|
| CHAR FOR BIT DATA | CHAR | EBCDIC | <p>EBCDIC tables that were added and loaded with product version 4.1 PTF-2 or later support columns with a data type of CHAR FOR BIT DATA. This means that queries can reference CHAR FOR BIT DATA columns in EBCDIC tables that were added with version 4.1 PTF-2 or a later version.</p> <p>Restriction: A query that references a FOR BIT DATA column can reference other columns that use supported data types, but only if these columns contain single-byte encoded (SBCS) data. That is, none of the other columns must contain MIXED data. Assuming that EBCDIC_MIXED_COL is a MIXED data column and EBCDIC_FOR_BIT_COL a FOR BIT DATA column in an EBCDIC table, a query of the following type cannot be accelerated:</p> <pre>SELECT .. FROM TABLE WHERE EBCDIC_MIXED_COL = 'abc' AND EBCDIC_FOR_BIT_COL = X'C1C2';</pre> <p>Queries referencing CHAR FOR BIT DATA columns in EBCDIC tables that were loaded with product version 4.1 PTF-1 or earlier will not be accelerated because the FOR BIT DATA columns have been excluded during the load. That is, these columns do not exist on the accelerator. Queries not referencing FOR BIT DATA columns continue to work. To enable FOR BIT DATA support for tables loaded with earlier versions, remove the relevant tables from the accelerator, then define and load these again.</p> |
| VARCHAR FOR BIT DATA | VARCHAR | EBCDIC | See the comment on VARCHAR FOR BIT DATA. It also applies here. |
| GRAPHIC | NVARCHAR | UNICODE (1200) EBCDIC (partially supported) | Normally, this type is supported for UNICODE only. To enable this type for EBCDIC, include the value 1 when setting QUERY_ACCEL_OPTIONS. |
| VARGRAPHIC | NVARCHAR | UNICODE (1200) EBCDIC (partially supported) | Normally, this type is supported for UNICODE only. To enable this type for EBCDIC, include the value 1 when setting QUERY_ACCEL_OPTIONS. |

Unsupported Db2 data types

- BINARY
- BLOB
- CLOB
- DBCLOB
- DECFLOAT
- Distinct (user-defined) data types
- ROWID
- VARBINARY
- XML

Related concepts

Conditions that prevent query routing to an accelerator

Db2 for z/OS does not route a query to an accelerator if any of the following conditions applies.

Supported SQL functions and expressions

IBM Db2 Analytics Accelerator for z/OS supports all aggregate functions, except for the XMLAGG function. In addition, IBM Db2 Analytics Accelerator for z/OS supports a variety of scalar functions and the CAST specification.

Supported scalar functions

| Function name | Function name | Function name | Function name |
|----------------------------------|---|--|---------------------------------------|
| • ABS | • DECIMAL | • LTRIM (also with two arguments) | • RTRIM (also with two arguments) |
| • ADD_MONTHS | • DECODE (also with two arguments) | • MAX (also GREATEST; see Table 10 on page 32) | • SECOND |
| • BIGINT | • DEGREES | • MEDIAN (see Table 10 on page 32) | • SIGN (see Table 10 on page 32) |
| • BITAND | • DIGITS | • MICROSECOND | • SMALLINT |
| • BITANDNOT | • DOUBLE_PRECISION (also DOUBLE, FLOAT) | • MIDNIGHT_SECONDS | • SPACE |
| • BITNOT | • EXP | • MIN (also LEAST; see Table 10 on page 32) | • SQRT |
| • BITOR | • EXTRACT | • MINUTE | • STRIP |
| • BITXOR | • FLOAT | • MOD | • SUBSTR (see Table 10 on page 32) |
| • CEILING | • FLOOR | • MONTH | • SUBSTRING (see Table 10 on page 32) |
| • CAST specification | • HOUR | • MONTHS_BETWEEN | • TIME |
| • CHAR (see Table 10 on page 32) | • IFNULL | • NEXT_DAY | • TIMESTAMP (see Table 10 on page 32) |

Table 9. Supported scalar functions and specifications (continued)

| Function name | Function name | Function name | Function name |
|---|---|--|---|
| • CHARACTER_LENGTH (see Table 10 on page 32) | • INTEGER (INT) | • NULLIF | • TIMESTAMPDIFF |
| • COALESCE | • JULIAN_DAY | • NVL (Rewriting to COALESCE no longer required. Also supported with two arguments.) | • TIMESTAMP_FORMAT |
| • CONCAT | • LAST_DAY (see Table 10 on page 32) | • POSITION (see Table 10 on page 32) | • TIMESTAMP_ISO (see Table 10 on page 32) |
| • CORR | • LCASE | • POSSTR (see Table 10 on page 32) | • TRANSLATE (see Table 10 on page 32) |
| • COVAR | • LEFT (see Table 10 on page 32) | • POWER | • TRIM (also with two arguments) |
| • COVAR_SAMP | • LENGTH (see Table 10 on page 32) | • QUARTER | • TRUNCATE (see Table 10 on page 32) |
| • DATE | • LN | • RADIANS | • UCASE |
| • DAY (see Table 10 on page 32) | • LOCATE (see Table 10 on page 32) | • REAL | • UPPER (see Table 10 on page 32) |
| • DAYOFMONTH | • LOCATE_IN_STRING (see Table 10 on page 32) | • REPEAT | • VALUE |
| • DAYOFWEEK | • LOG10 | • REPLACE (see Table 10 on page 32) | • VARCHAR (see Table 10 on page 32) |
| • DAYOFWEEK_ISO | • LOG | • RIGHT (see Table 10 on page 32) | • VARCHAR_FORMAT (see Table 10 on page 32) |
| • DAYOFYEAR | • LOWER (see Table 10 on page 32) | • ROUND | • WEEK_ISO |
| • DAYS | • LPAD (see Table 10 on page 32) | • RPAD (see Table 10 on page 32) | • YEAR |

Table 10. Restrictions

| Function name | Restriction |
|--|---|
| <ul style="list-style-type: none"> • BITAND • BITANDNOT • BITNOT • BITOR • BITXOR | Arguments must be of the type BIGINT, INT, or SMALLINT. |

Table 10. Restrictions (continued)

| Function name | Restriction |
|--|---|
| <ul style="list-style-type: none"> CHAR | <ul style="list-style-type: none"> If CHAR is used for character-to-character or graphic-to-character conversions, one of the arguments in the expression must be of type CODEUNIT16 or CODEUNIT32. If one of the arguments of this function is a string encoded in UTF-8 or UTF-16, enable support by setting the QUERY_ACCEL_OPTIONS parameter (a ZPARAM) to the value 3. Mind that result deviations can occur if the input string contains multibyte characters. |
| <ul style="list-style-type: none"> CAST specification CHARACTER_LENGTH LEFT LENGTH LOCATE LOCATE_IN_STRING | <p>Enable support by setting the QUERY_ACCEL_OPTIONS parameter (a ZPARAM) to the value 3 if one of these conditions applies:</p> <ul style="list-style-type: none"> One of the arguments is of the type CODEUNITS16 or OCTETS. One of the arguments is a string encoded in UTF-8 or UTF-16. Mind that result deviations can occur if the input string contains multibyte characters. <p>Important: LEFT is supported for character and graphic strings only.</p> |
| <ul style="list-style-type: none"> DAY | The argument must not be of the type INTEGER or FLOAT. |
| <ul style="list-style-type: none"> LAST_DAY | The argument must not be a timestamp. |
| <ul style="list-style-type: none"> LENGTH | The argument must be of type CHAR or VARCHAR. Numeric types, time values, date values, or timestamps cannot be used. |
| <ul style="list-style-type: none"> LOWER (LCASE) | <ul style="list-style-type: none"> If one of the arguments of this function is a string encoded in UTF-8 or UTF-16, enable support by setting the QUERY_ACCEL_OPTIONS parameter (a ZPARAM) to the value 3. Mind that result deviations can occur if the input string contains multibyte characters. When a query is accelerated, the value of the locale argument is ignored and en_US is used instead. |
| <ul style="list-style-type: none"> LPAD | If one of the arguments of this function is a string encoded in UTF-8 or UTF-16, enable support by setting the QUERY_ACCEL_OPTIONS parameter (a ZPARAM) to the value 3. Mind that result deviations can occur if the input string contains multibyte characters. |
| <ul style="list-style-type: none"> MAX MIN | Arguments of this function must be of the type BIGINT, INT, or SMALLINT. In addition, no more than four arguments are allowed. If these criteria are not met, the query or operation is not accelerated. |
| <ul style="list-style-type: none"> MEDIAN | This function is fully supported by Db2 11 for z/OS, but not by Db2 10 for z/OS. In connection with Db2 10 for z/OS, you can only run the MEDIAN function on an accelerator. This means that a query including this function will inevitably fail if the accelerator becomes unavailable because failback processing is not possible. |
| <ul style="list-style-type: none"> POSITION | If one of the arguments of this function is of the type CODEUNITS16 or OCTETS, enable support by setting the QUERY_ACCEL_OPTIONS parameter (a ZPARAM) to the value 3. |
| <ul style="list-style-type: none"> POSSTR REPLACE | If one of the arguments of this function is a string encoded in UTF-8 or UTF-16, enable support by setting the QUERY_ACCEL_OPTIONS parameter (a ZPARAM) to the value 3. Mind that result deviations can occur if the input string contains multibyte characters. |

Table 10. Restrictions (continued)

| Function name | Restriction |
|--|--|
| <ul style="list-style-type: none"> • RIGHT | <p>Enable support by setting the QUERY_ACCEL_OPTIONS parameter (a ZPARAM) to the value 3 if one of these conditions applies:</p> <ul style="list-style-type: none"> • One of the arguments is of the type CODEUNITS16 or OCTETS. • One of the arguments is a string encoded in UTF-8 or UTF-16. Mind that result deviations can occur if the input string contains multibyte characters. |
| <ul style="list-style-type: none"> • RPAD • SUBSTR | <p>If one of the arguments of this function is a string encoded in UTF-8 or UTF-16, enable support by setting the QUERY_ACCEL_OPTIONS parameter (a ZPARAM) to the value 3. Mind that result deviations can occur if the input string contains multibyte characters.</p> |
| <ul style="list-style-type: none"> • SIGN | <p>Arguments must not be of the data type DECFLOAT.</p> |
| <ul style="list-style-type: none"> • SUBSTRING | <p>SUBSTRING is supported only if the expression refers to character or graphic data types. To enable support for graphic data types, set the QUERY_ACCEL_OPTIONS parameter (a ZPARAM) to the value 3.</p> |
| <ul style="list-style-type: none"> • TIMESTAMP | <p>The following restrictions with regard to the formats of string literals that can be used as timestamps do not apply if Netezza Platform Software (NPS®) 7.2 or later is used. However, they do apply if you still use an older version of NPS. That is, string literals in the following formats are not supported as arguments of the TIMESTAMP function:</p> <ul style="list-style-type: none"> • String literals with a space character () or dash (-) as the separator (delimiter) between the date and the time portion and a period (.) or colon (:) to separate hours, minutes, and seconds: <p>Examples:</p> <ul style="list-style-type: none"> – yyyy-mm-dd[hh .mm .ss [. nnnnnn]] (space character before hh; period to separate hours, minutes, and seconds) – yyyy-mm-dd[-hh :mm :ss [. nnnnnn]] (dash before hh; colon to separate hours, minutes, and seconds) <ul style="list-style-type: none"> • String literals with the capital letter T as the separator (delimiter) between the date and the time portion and a period (.) or colon (:) to separate hours, minutes, and seconds: <ul style="list-style-type: none"> – yyyy-mm-dd[T hh .mm .ss [. nnnnnn]] (T before hh; period to separate hours, minutes, and seconds) – yyyy-mm-dd[T hh :mm :ss [. nnnnnn]] (T before hh; colon to separate hours, minutes, and seconds) |
| <ul style="list-style-type: none"> • TIMESTAMP_ISO | <p>The argument must not be of the type CHAR or VARCHAR.</p> |
| <ul style="list-style-type: none"> • TRANSLATE | <p>If one of the arguments of this function is a string encoded in UTF-8 or UTF-16, enable support by setting the QUERY_ACCEL_OPTIONS parameter (a ZPARAM) to the value 3. Mind that result deviations can occur if the input string contains multibyte characters.</p> |
| <ul style="list-style-type: none"> • TRUNCATE | <p>You cannot use the TRUNCATE function on accelerator-only tables.</p> |

Table 10. Restrictions (continued)

| Function name | Restriction |
|--|--|
| <ul style="list-style-type: none"> • UPPER (UCASE) | <ul style="list-style-type: none"> • If one of the arguments of this function is a string encoded in UTF-8 or UTF-16, enable support by setting the QUERY_ACCEL_OPTIONS parameter (a ZPARAM) to the value 3. Mind that result deviations can occur if the input string contains multibyte characters. • When a query is accelerated, the value of the locale argument is ignored and en_US is used instead. |
| <ul style="list-style-type: none"> • VARCHAR | <p>Enable support by setting the QUERY_ACCEL_OPTIONS parameter (a ZPARAM) to the value 3 if one of these conditions applies:</p> <ul style="list-style-type: none"> • If VARCHAR is used for character-to-varchar or graphic-to-varchar conversions, and one of the arguments of the function is of the type CODEUNIT16 or OCTETS. • One of the arguments is a string encoded in UTF-8 or UTF-16. Mind that result deviations can occur if the input string contains multibyte characters. |
| <ul style="list-style-type: none"> • VARCHAR_FORMAT | <p>Queries that use the VARCHAR_FORMAT function cannot be accelerated if one of the function arguments is of data type DOUBLE or FLOAT. Example of a query that fails:</p> <pre>SELECT VARCHAR_FORMAT(CAST(1 AS DOUBLE)) AS COL FROM SCHEMA1.TABLE1</pre> |

Unsupported scalar functions

Table 11. Unsupported scalar functions

| | | |
|--------------------|----------------------|-----------------|
| • BINARY | • GENERATE_UNIQUE | • RAISE_ERROR |
| • BLOB | • GETHINT | • RAND |
| • COLLATION_KEY | • GETVARIABLE | • ROWID |
| • COMPARE_DECFLOAT | • GRAPHIC | • SCORE |
| • CONTAINS | • HEX | • SOA <xxx> |
| • DBCLOB | • IDENTITY_VAL_LOCVL | • SOUNDEX |
| • DECFLOAT | • MQ <xxx> | • TOTALORDER |
| • DECFLOAT_SORTKEY | • NORMALIZE_DECFLOAT | • VARBINARY |
| • DIFFERENCE | • NORMALIZE_STRING | • VARGRAPHIC |
| • DECRYPT <xxx> | • OVERLAY | • WEEK |
| • ENCRYPT_TDES | • QUANTIZE | • <xxx>XML<xxx> |

Supported special registers

IBM Db2 Analytics Accelerator for z/OS supports most Db2 special registers. During SQL routing to an accelerator, these special registers are replaced with the equivalent Netezza functions or with a literal string containing the register's value at the time of statement execution. In some cases, this leads to different query results.

The following special registers are supported by Netezza function substitution:

- CURRENT ACCELERATOR
- CURRENT APPLICATION COMPATIBILITY
- CURRENT APPLICATION ENCODING SCHEME
- CURRENT CLIENT_ACCTNG
- CURRENT CLIENT_APPLNAME
- CURRENT CLIENT_CORR_TOKEN
- CURRENT CLIENT_WRKSTNNAME
- CURRENT DATE

Replaced with the Netezza function CURRENT_DATE on the accelerator.

- CURRENT DEBUG MODE
- CURRENT DECFLOAT ROUNDING MODE
- CURRENT DEGREE
- CURRENT EXPLAIN MODE
- CURRENT GET_ACCEL_ARCHIVE
- CURRENT LOCALE LC_CTYPE
- CURRENT MAINTAINED TABLE TYPES FOR OPTIMIZATION
- CURRENT MEMBER
- CURRENT OPTIMIZATION HINT
- CURRENT PACKAGE PATH
- CURRENT PACKAGESET
- CURRENT PATH
- CURRENT PRECISION
- CURRENT QUERY ACCELERATION
- CURRENT QUERY ACCELERATION WAITFORDATA
- CURRENT REFRESH AGE
- CURRENT ROUTINE VERSION
- CURRENT RULES
- CURRENT SCHEMA
- CURRENT SERVER
- CURRENT SQLID
- CURRENT TEMPORAL BUSINESS_TIME
- CURRENT TEMPORAL SYSTEM_TIME
- CURRENT TIME

Replaced with the Netezza function CURRENT_TIME on the accelerator.

Restriction: Microseconds are not returned in the query results. A zero is displayed in the positions where you would expect microseconds.

- CURRENT TIMESTAMP

Replaced with the following Netezza TIMESTAMP function:

```
TIMESTAMP(to_char(current_timestamp, 'yyyy-mmdd-hh.mm.ss.ts'))
```

Restriction: Microseconds are not returned in the query results. A zero is displayed in the positions where you would expect microseconds.

- SESSION_USER

- SESSION TIME ZONE

Most of the remaining special registers are supported through literal string substitution in the SQL. For example, a reference to CURRENT SQLID will be replaced in the SQL with the literal string value from that register before the SQL is submitted to Netezza for processing.

Conditions that prevent query routing to an accelerator

Db2 for z/OS does not route a query to an accelerator if any of the following conditions applies.

- You use a distributed data facility (DDF) client, such as an Open Database Connectivity (ODBC) client, that does not support *level 8* of the IBM Distributed Relational Database Architecture™ (DRDA).
- The encoding scheme of an SQL statement is M because the tables use different encoding schemes, or the query contains an expression that explicitly relates to a coded character set identifier (CCSID), for example, a cast specification with a CCSID option.
- The FROM clause of the query specifies a data-change-table-reference, or, in other words, the query is selected from a FINAL TABLE or from an OLD TABLE.
- The query contains a correlated table expression. A correlated table expression is a table expression that contains one or more correlated references to other tables in the same FROM clause. For example:

```
SELECT ... FROM TA A, TABLE ( SELECT ... FROM TB B WHERE B.C1 = A.C1) TX (...),
TC WHERE ...
```

- The query contains a recursive common table expression reference.
- Your version of the Netezza Platform Software (NPS) is lower than 7.0.4 and the query contains one of the following predicates:
 - = ALL (<subquery>) (equal to)
 - <> ALL (<subquery>) (not equal to)
 - > ALL (<subquery>) (greater than)
 - < ALL (<subquery>) (less than)
 - >= ALL (<subquery>) (greater than or equal to)
 - <= ALL (<subquery>) (less than or equal to)
 - NOT IN (<subquery>)
- The query contains a string expression (including columns) with an unsupported subtype. See [Table 7 on page 29](#).
- The query contains an expression with an unsupported result data type or subtype. See [“Supported data types” on page 27](#).
- The query refers to a column that uses a field procedure (FIELDPROC).
- The query uses a special register other than:
 - CURRENT DATE
 - CURRENT TIME
 - CURRENT TIMESTAMP
- A LOCAL date format is used, that is, one or more of the following conditions apply:
 1. The query contains a CHAR function in which LOCAL is specified as the second argument.
 2. The query contains a date or time expression and the DATE FORMAT field of the DSNTIP4 installation panel specifies LOCAL.
 3. Application programs that process SQL on Db2 for z/OS have been precompiled with the DATE(LOCAL) option.

Exception: You can enable LOCAL date expressions in the format dd/mm/yyyy or yyyyymmdd (with two space characters at the end) by including the QUERY_ACCEL_OPTIONS ZPARM value 4 or 7. For

more information, see *Installing Db2 libraries with IBM Db2 Analytics Accelerator for z/OS support* in the *IBM Db2 Analytics Accelerator for z/OS: Installation Guide*.

- The query contains a sequence expression (NEXTVAL or PREVVVAL).
- The query contains a user-defined function (UDF)
- The query contains a ROW CHANGE expression
- The query contains a string constant that is longer than 16000 characters.
- A new column name is referenced in a sort-key expression, for example:

```
SELECT C1+1 AS X, C1+2 AS Y FROM T WHERE ... ORDER BY X+Y;
```

- The query contains a correlated subquery that the accelerator cannot handle. In such a case, the Db2 EXPLAIN table DSN_QUERYINFOTABLE shows the value 21 in the REASON_CODE column. The term *correlated* means that the scalar fullselect references a column of a table or view that is named in an outer subselect. For example, a query will be blocked if any of the following conditions applies:

- All of the following is true:
 1. The subquery correlates directly with its parent.
 2. The subquery contains an IFNULL, COALESCE, VALUE, or CASE expression.
 3. The parameter of any of these expressions is an aggregate function.

Example:

```
SELECT * FROM T2 AS A
WHERE C0=(SELECT COALESCE(MAX(C0),1)
FROM T2 AS B
WHERE A.C0=B.C0 AND 1=2);
```

- The subquery is in a NOT-IN list.
- The predicate (WHERE clause) of the subquery specifies an IS NULL condition when the column is defined as NOT NULL.

Example: C3SINT is defined as NOT NULL:

```
SELECT * FROM T1
WHERE C1 = C2
AND C1 in (SELECT C1 FROM T2 WHERE T2.C3SINT IS NULL)
```

- The previous restrictions for correlated subqueries no longer exist in Db2 11 for z/OS and later versions. However, the following restriction still holds true for all supported Db2 for z/OS versions (including Db2 11 for z/OS):

The query contains a correlated scalar fullselect query in an IN list.

Example:

```
SELECT * FROM TEST2 T1 WHERE T1.C0 IN
(2,(SELECT C0 FROM TEST2 T2 WHERE T1.C1=T2.C1),3);
```

For more information, follow the appropriate link under **Related information** at the end of this topic.

- All three of the following statements are true for character-based scalar functions or cast specification expressions in a query:
 - The CODEUNIT16, OCTETS, or NO CODEUNITS option is used.
 - The QUERY_ACCEL_OPTION parameter does not include the value 3.
 - The string arguments are not single-byte (SBCS) values.
- The query contains a cast specification expression with a result data type of GRAPHIC or VARGRAPHIC.
- The query contains one of the following scalar functions or cast specification expressions with a string argument that is encoded in UTF-8 or UTF-16. The problem occurs because Netezza evaluates the character values of these string functions, whereas Db2 evaluates the byte values.

- CAST (arg as CHAR(*n*))
- CAST(arg AS VARCHAR(*n*)) where *n* is less than the length of the argument
- CHAR
- CHARACTER_LENGTH
- LEFT
- LENGTH
- LOCATE
- LOCATE_IN_STRING
- LOWER(arg, *n*) where *n* is not equal to the length of the argument
- LPAD
- POSSTR
- REPLACE
- RIGHT
- RPAD
- SUBSTR
- TRANSLATE (if more than one argument is specified)
- UPPER(arg, *n*) where *n* is not equal to the length of the argument
- VARCHAR(arg, *n*) where *n* is less than the length of the argument

Note: To enable these types for query routing to an accelerator, include the value 3 in the setting of QUERY_ACCEL_OPTIONS. Result deviations might occur if the input string contains multibyte characters.

- The query uses a LENGTH function, but the argument of this function is not a string or is encoded in UTF-8 or UTF-16. To enable query acceleration for queries containing the LENGTH function with an argument of these types, include option 3 in the value of QUERY_ACCEL_OPTIONS.
- The query uses a DAY function where the argument of the function specifies a duration.
- Db2 10 for z/OS: The query uses the LAST_DAY function and specifies a TIMESTAMP expression as its first argument.
- The query uses the *scalar* MIN or MAX function with more than four arguments or the result of the scalar MIN or MAX expression is not of the INTEGER or FLOAT data type.
- The query uses a TRANSLATE function with only two arguments.
- The query uses one of the following scalar functions and one or more of its arguments contain a parameter marker or a scalar fullselect:
 - LOCATE
 - MICROSECOND
 - MIDNIGHT_SECONDS
 - TRANSLATE
- The query uses the EXTRACT function, and the function specifies that the SECOND portion of a TIME or TIMESTAMP value must be returned.
- The query uses one of the following aggregate functions with the DISTINCT option:
 - STDDEV
 - STDDEV_SAMP
 - VARIANCE
 - VAR_SAMP
- The query uses a table function, such as ADMIN_TASK_LIST or ADMIN_TASK_STATUS.
- The query uses an unsupported scalar function. See [Table 11 on page 35](#)

- The instruction to process “SELECT FROM ... INSERT INTO ... ” statements (ZPARAM QUERY_ACCEL_OPTIONS includes the value 2) is ignored if the target table uses an encoding scheme that is different from the encoding scheme of the tables in the SELECT statement.
- A *static* SQL query that includes a FOR SYSTEM_TIME ... or FOR BUSINESS_TIME ... is not routed to an accelerator if one of the following bind options (value YES, default) is used.

| <i>Table 12. Unsupported bind options</i> | |
|--|---|
| Clause | Bind option (value YES, which is the default) |
| <ul style="list-style-type: none"> – FOR BUSINESS_TIME AS OF – FOR BUSINESS_TIME FROM ... TO ... – FOR BUSINESS_TIME BETWEEN ... AND... | <ul style="list-style-type: none"> – BUSTIMESENSITIVE – BUSINESS_TIME SENSITIVE |
| <ul style="list-style-type: none"> – FOR SYSTEM_TIME AS OF – FOR SYSTEM_TIME FROM ... TO ... – FOR SYSTEM_TIME BETWEEN ... AND ... | <ul style="list-style-type: none"> – SYSTIMESENSITIVE – SYSTEM_TIME SENSITIVE |

In cases like this, you receive error message -4742 with reason code 18.

Related concepts

EXPLAIN information

After creating the necessary EXPLAIN tables, you can analyze queries by invoking the Db2 EXPLAIN function. Such queries are accepted by regular and virtual accelerators alike. The analysis shows whether a query can be accelerated, indicates the reason for a failure, and gives a response time estimate. The outcome of the analysis can also be visualized in an access plan graph.

Related information

How IBM DB2 Analytics Accelerator for z/OS handles correlated subqueries

Isolation levels

Db2 isolation levels are ignored by IBM Db2 Analytics Accelerator for z/OS.

Every table on an accelerator has its counterpart. That is, the table has been derived from a table that resides in Db2 for z/OS. An accelerator-shadow table is thus a copy of a projection of a Db2 table. In most cases, the projection is the Db2 table itself. Columns of the original Db2 table are excluded from the projection only if a column uses an unsupported data type.

You can change a Db2 table practically at any time by means of INSERT, UPDATE, or DELETE operations, mass imports (LOAD), and schema modifications (selected DDL). In this version of IBM Db2 Analytics Accelerator for z/OS, changes to a Db2 table are propagated automatically to the associated accelerator-shadow table only if the incremental update feature is used. If incremental updates are not enabled, you must update the accelerator-shadow tables manually in order to synchronize the table data. You can start the update from your administration client or run the SYSPROC.ACCEL_LOAD_TABLES stored procedure for this purpose.

The update of accelerator-shadow tables is an asynchronous process, that is, there is no guarantee that the data in the Db2 tables and the data in the accelerator-shadow tables are always in sync. Therefore, the result set that a query returns when it is processed by Db2 might differ from the result set that the same query produces when it is processed by IBM Db2 Analytics Accelerator for z/OS. This implies that isolation levels set for Db2 data are ignored or must be ignored by applications that send queries to IBM Db2 Analytics Accelerator for z/OS. Result sets that are returned by IBM Db2 Analytics Accelerator for z/OS do not necessarily comply with any isolation level setting.

To ensure that a query "sees" the latest committed Db2 for z/OS changes on the accelerator, you can combine the incremental update feature with a value > 0 for the CURRENT QUERY ACCELERATION WAITFORDATA special register. In this case, the query will wait (for the maximum time specified) for the

asynchronous propagation of the Db2-side changes to the accelerator. This ensures data consistency on a relatively safe level.

However, this approach still does not prevent concurrent units of work from updating the tables referenced by a query. So a query running under isolation level RR or RS that is accelerated does not hold any read locks in Db2 and thus cannot prevent that a concurrent writer commits changes to the rows seen by the query. So applications that rely on locks and the RR or RS protocol should not be enabled for query acceleration. For these applications, set the CURRENT QUERY ACCELERATION special register to the value NONE.

Related concepts

Updating accelerator tables continually

The incremental update function of IBM Db2 Analytics Accelerator for z/OS allows you to update accelerator-shadow tables continually. Changes to the data in original Db2 for z/OS tables are thus propagated to the corresponding target tables with a high frequency and just a brief delay. This way, query results from an accelerator are always extracted from recent, close-to-real-time data.

Related tasks

Loading tables

Successful queries against accelerator-shadow tables are possible only if the tables contain data. Therefore, you must load the tables after their definition (empty structure) has been copied to the accelerator.

Incompatibilities between Db2 for z/OS and IBM Db2 Analytics Accelerator for z/OS

In the list of incompatibilities, you find explanations for execution errors or different query results that Db2 for z/OS and IBM Db2 Analytics Accelerator for z/OS might return for the same query.

Correlated subqueries

IBM Db2 Analytics Accelerator for z/OS cannot handle correlated subqueries if the subquery cannot be de-correlated internally. If a query that was routed to an accelerator contains a correlated subquery, the query might fail. In this case, the query is returned to Db2 for processing (FAILBACK). To find out which correlated subqueries are supported, see the external document that is referenced under **Related information** at the end of this topic.

Related information

[How IBM DB2 Analytics Accelerator for z/OS handles correlated subqueries](#)

COUNT_BIG function

During query routing to an accelerator, the aggregate Db2 function COUNT_BIG is converted to the COUNT function, which is the corresponding accelerator function. The Db2 COUNT_BIG function returns DECIMAL(31,0) values, while the accelerator COUNT function returns BIGINT values. If the result returned by the accelerator function COUNT exceeds the maximum length that can be represented by the BIGINT data type, an accelerated query fails. The same query would succeed in Db2 as long as the result of COUNT_BIG can be represented in a DECIMAL(31,0) value.

Data types

See how IBM Db2 Analytics Accelerator handles certain Db2 data types:

CHAR (n)

During query routing to an accelerator, the Db2 UTF-8 data type CHAR (n) is converted to the NVARCHAR (n) data type. Bear this in mind if your queries contain rules regarding the result data type. These can be, for example, result expressions that use the CASE function on set operations such as UNION, INTERSECT, or EXCEPT. The result data type will be CHAR in Db2 and VARCHAR in IBM Db2 Analytics Accelerator for z/OS. This affects the output if Db2 for z/OS internally uses padding to

cast the results to the expected data type. Inhouse Db2 queries and accelerated queries might return different results.

FLOAT

The FLOAT data type is an approximate data type. The result can be different due to platform differences (hexadecimal floating-point numbers (HFP) versus IEEE754 floating-point numbers) or other internal handling differences. This applies to expressions that return FLOAT data and to expressions that contain a FLOAT data-type argument.

Related concepts

[Differences in floating-point error tolerances](#)

For queries that involve floating-point aggregates, you can expect IBM Db2 Analytics Accelerator for z/OS to produce results that are different from those delivered by inhouse Db2 for z/OS processing.

Division and multiplication of decimal values

During the division or multiplication of decimal values, Db2 for z/OS might truncate operand values if at least one of the operands is defined with a precision greater than 15. If that happens, the result of the calculation will be imprecise or wrong. IBM Db2 Analytics Accelerator for z/OS does not truncate operand values internally, so the results will be more precise.

Example: Consider the following query:

```
CREATE TABLE TEST_TABLE(
  D_DECIMAL_4_2 DECIMAL(4,2),
  D_DECIMAL_17_2 DECIMAL(17,2),
  D_DECIMAL_30_6 DECIMAL(30,6)
);
INSERT INTO TEST_TABLE VALUES(3.5, 3.5, 0.5);
INSERT INTO TEST_TABLE VALUES(1.5, 1.5, 1.5);

SELECT D_DECIMAL_17_2/D_DECIMAL_30_6, D_DECIMAL_17_2*D_DECIMAL_30_6
FROM TEST_TABLE;

SELECT D_DECIMAL_4_2/D_DECIMAL_30_6, D_DECIMAL_4_2*D_DECIMAL_30_6
FROM TEST_TABLE;
```

Db2 for z/OS returns results as follows:

- For the first calculation in the query:

```
+-----+
| ? | 1.5 |
| 1 | 1.5 |
+-----+
```

- For the second calculation in the query:

```
+-----+
| ? | 1.75 |
| 1.5 | 2.25 |
+-----+
```

The question mark (?) means that an overflow has occurred (division by zero) because Db2 for z/OS has internally reduced the value 0.5 to 0.

IBM Db2 Analytics Accelerator for z/OS would have returned the correct results, which are the same for both calculations in the query:

```
+-----+
| 7 | 1.75 |
| 1 | 2.25 |
+-----+
```

The truncation problem is discussed in subsections of the *Arithmetic with two decimal operands* topic of the SQL reference in the Db2 10 for z/OS information center. A link to this topic is provided under **Related information**.

Related information

[Arithmetic with two decimal operands](#)

Encoding issues

Consider the following points when you have to deal with Unicode SQL statements, multibyte (mixed) data in connection with parameter markers, and multibyte or double-byte EBCDIC columns.

Unicode SQL statements

Generally, when a UNICODE-encoded SQL statement contains characters or strings (as a literal, host variable, or parameter marker) that refer to a single-byte-encoded EBCDIC column, then Db2 tries to convert these strings to EBCDIC. Sometimes, such a string cannot be converted properly because it contains invalid UNICODE characters or characters that do not exist in the target EBCDIC code page. In such cases, the results of the SQL operation and the SQLCODE returned by the accelerator might be different from those returned by Db2 for z/OS with regard to the following aspects:

- Queries might return a different number of rows.
- SQLCODE 0 might be returned instead of the SQL warning codes +331 or +335.
- Different substitution characters might be put into returned or inserted strings.
- Returned or inserted strings or substitution characters might be different if multiple encoding is enabled on the accelerator.

Mixed data and parameter markers

If a Db2 subsystem is set up to contain mixed data (`mixed=yes`), that is, if differently encoded data is allowed to coexist, and the coded character set identifier (CCSID) is not specified for parameter markers in a query, the query might return incorrect results.

Multibyte and double-byte EBCDIC columns

Columns encoded in EBCDIC MIXED or DBCS are only partially supported by IBM Db2 Analytics Accelerator for z/OS. This is why you must explicitly enable the routing of queries that refer to such columns to an accelerator. In Db2, the data in such columns is encoded in EBCDIC, but in IBM Db2 Analytics Accelerator for z/OS, it is encoded in Unicode (UTF-8). These encoding schemes have significant differences that can lead to different result sets depending on whether the query is executed in Db2 or on the accelerator. **Examples:** EBCDIC and Unicode implement different collating sequences. The collating sequence for Unicode is numeric, uppercase characters, and then lowercase characters (1, 2, 3, A, B, C, a, b, c). In EBCDIC, the collating sequence is lowercase, uppercase, and then numeric characters (a, b, c A, B, C, 1, 2, 3). The collating sequences for national characters are also different. This affects both, data ordering and the results from range predicates. Therefore, if the tables include character columns where the column values belong to more than one of these groups and the SQL statements include range predicates or ordering on these columns, a query executed in Db2 might return a different result set than the same query executed in IBM Db2 Analytics Accelerator for z/OS.

Another prominent example is the different handling of blanks in some cases.

On the contrary, there are many situations in which Db2 data in multi-byte EBCDIC tables can be processed by IBM Db2 Analytics Accelerator for z/OS without problems. However, to avoid problems, always contact IBM support before you connect an accelerator to a Db2 subsystem that contains table data in EBCDIC MIXED or DBCS encoding.

Exception handling

When an exception, such as a buffer overflow, a division by zero, or an out-of-range value occurs, Db2 returns the value NULL combined with a +802 warning, provided that the faulty expression is in the outermost SELECT statement and affects only one row. This is also called *friendly arithmetic*. IBM Db2 Analytics Accelerator for z/OS will always issue an error in cases like these.

Maximum row length

The maximum row length for a table on an accelerator is 65535 bytes. If the combined length of all column fields in a Db2 table exceeds this limit, you cannot define that table on an accelerator.

Predicate evaluation

Db2 tolerates SQL errors during predicate evaluation as long as the error has no impact on the result of the evaluation. IBM Db2 Analytics Accelerator for z/OS, on the contrary, always returns an error. This rule applies to predicates consisting of multiple terms (an SQL error in a predicate consisting of only one term cannot be tolerated). An SQL error in a predicate does not influence the outcome of the predicate evaluation if it does not matter whether the error makes the predicate logically *true* or *false*. For example, if the predicate is a conjunction of terms as in *P1 AND P2*, and the evaluation of *P1* results in an SQL error, then this error does not influence the outcome if *P2* evaluates to *false* because both, *true AND P2* and *false AND P2*, evaluate to *false*. [Table 13 on page 44](#) shows all relevant permutations for two-term predicates (E = *error*, T = *true*, F = *false*). Values in parentheses indicate that the *P2* term is not evaluated if an evaluation of *P1* already yields the result of the entire predicate evaluation.

| P1 | P2 | P1 AND P2 | P1 OR P2 |
|----|----|-----------|----------|
| E | E | E | E |
| E | T | E | T |
| E | F | F | E |
| T | E | E | (T) |
| F | E | (F) | E |

The reason for choosing this evaluation method is that Db2 sometimes changes the order of term evaluation internally. The change is not announced or reported, and therefore goes unnoticed. Depending on the order of term evaluation, Db2 returns an error in one case, but not the other.

The behavior is very similar for the CASE and DECODE functions. These are basically SQL implementations of IF ... THEN ... ELSE constructs and exist in Db2 and IBM Db2 Analytics Accelerator. Db2 will ignore a wrongly defined option as long as it can select a correct one that evaluates to true. IBM Db2 Analytics Accelerator, on the other hand, will first check all available options, and return an error if one of these is not correctly defined. In the latter case, it does not matter whether selecting one of the correctly defined options would have led to a correct result.

Scalar functions

See how the behavior of certain scalar functions deviates from the behavior of these functions in Db2 for z/OS.

DATE(numeric_exp)

See [DATE\(numeric_exp\)](#) scalar function.

LEFT

If the second argument of the LEFT scalar function contains a parameter marker or value that is longer than the value of the first argument, the padding of the second argument value in IBM Db2 Analytics Accelerator for z/OS might be different from the padding in Db2 for z/OS.

LOCATE

The Db2 scalar functions LOCATE and LOCATE_IN_STRING are converted to the INSTR function. That is, LOCATE(search, source, start) ends up as

INSTR(source, search, start) and LOCATE_IN_STRING(source, search, start, instance) ends up as INSTR(source, search, start, instance). If the starting point is an expression that returns a negative value, IBM Db2 Analytics Accelerator for z/OS evaluates the expression from the right with an offset of 1. If the converted query is executed in Db2 (due to a FAILBACK, for example), LOCATE returns an error with SQLCODE171, while LOCATE_IN_STRING will give you a result that differs from the result returned by the original Db2 query.

LOCATE_IN_STRING

See [LOCATE](#).

LOWER

- Db2 and IBM Db2 Analytics Accelerator for z/OS might return different results if the UPPER, LOWER, or TRANSLATE scalar functions are used. The differences are as follows:

Functions that do not use a locale setting (specified explicitly or by means of a special register)

When a query is not routed to an accelerator, only the plain Latin letters from a-z and from A-Z are converted to uppercase or lowercase. If the incoming data is encoded using a MIXED or a double-byte character set (DBCS), the entire set of Latin characters is converted.

When a query is routed to an accelerator, the characters with diacritical marks are converted in addition to the plain Latin characters from a-z or from A-Z. In other words, more characters are converted to uppercase or lowercase if a query is accelerated.

For functions that do use a locale setting (specified explicitly or by means of a special register)

When a query is not routed to an accelerator, special characters (as defined in the Unicode file SpecialCasing.txt) are converted to uppercase or lowercase.

When the query is routed to an accelerator, these special characters are not converted.

This might lead to the following differences in your query results:

- Db2 and IBM Db2 Analytics Accelerator for z/OS return different numbers of rows for the same query if the UPPER or LOWER function is used in a predicate.
 - Db2 and IBM Db2 Analytics Accelerator for z/OS return rows in different orders or group rows differently if the UPPER or LOWER function is used in an ORDER BY or GROUP BY clause.
 - Db2 and IBM Db2 Analytics Accelerator for z/OS return different data. For example, the results of any aggregate function can differ if UPPER or LOWER is used in a GROUP BY clause or in a predicate. Some characters will show a different case (uppercase in Db2 results, lowercase in accelerator results, or vice versa).
 - Other differences are possible, depending on where the UPPER or LOWER function appears in the query.
- IBM Db2 Analytics Accelerator for z/OS does not support string functions like UPPER() and LOWER() for strings with termination characters (0x00) in the following constructs:
 - Literals
 - CHAR columns
 - VARCHAR columns
 - GRAPHIC columns
 - VARGRAPHIC columns

The resulting strings are truncated. The truncation starts at the first termination character.

MONTHS_BETWEEN

The result data type of the MONTHS_BETWEEN scalar function in Db2 is DECIMAL(31,15). In IBM Db2 Analytics Accelerator for z/OS, it is NUMERIC(17,9). As a consequence, the query results contain fewer digits if such a query is routed to and processed by IBM Db2 Analytics Accelerator for z/OS.

NEXT_DAY

Db2 and IBM Db2 Analytics Accelerator for z/OS might return different results in connection with the NEXT_DAY scalar function if the function handles years before the year 1582. For years before 1582, Db2 uses Julian calendar dates while IBM Db2 Analytics Accelerator for z/OS continues to use Gregorian calendar dates.

ROUND

If the second argument of the ROUND or TRUNC scalar function is less than -38 or greater than 37, Db2 for z/OS can still evaluate the expression, whereas IBM Db2 Analytics Accelerator for z/OS will return an error.

SUBSTR

If the SUBSTR scalar function (SUBSTR(*string-expression*, *start*, *length*)) uses a start position that is greater than the value of *length*, Db2 returns SQLCODE138. IBM Db2 Analytics Accelerator for z/OS returns an empty string.

TRANSLATE

- See [LOWER](#).
- If the value of *from-str* in the TRANSLATE scalar function (TRANSLATE(*str*, *to-str*, *from-str*)) is an expression that returns an empty string, Db2 returns SQLCODE171. IBM Db2 Analytics Accelerator for z/OS returns the first argument.

TRUNC

See [ROUND](#).

UPPER

See [LOWER](#).

SQL issues

In a grouping select, the HAVING clause can only reference expressions that are single-valued within a group. That is, you can only reference group fields, aggregates, or single-valued expressions that are derived from group fields or aggregates (which must include constants).

Time and date values

Time and date constructs in the Netezza database often differ from the constructs used by Db2 for z/OS, so that values and expressions must be converted. The conversion is often accompanied by limitations.

24:00:00 conversion

This product supports the Db2 for z/OS time representation 24.00.00 for midnight (end of day) in TIME and TIMESTAMP columns or SQL expressions. There is no need to set up a conversion.

Restrictions:

- The value 23:59:59.999999 must not occur in your data and must not be used in SQL expressions because it is needed internally for the automatic conversion.
- 24:00:00 can never be the result of an arithmetic calculation. For example, 00:00:00 + 24 hours will be 00:00:00 (on the next day) rather than 24:00:00, as in Db2 for z/OS.

If you have used the LOAD_ENABLE_HOUR24_CONVERSION parameter so far, and now want to use the native 24:00:00 support, you must set this parameter to the value `false`. A menu entry has been added to the IBM Db2 Analytics Accelerator Console for doing this, so that the conversion can be switched off

without the help of an IBM support person. If your accelerators contain tables with converted values, you have to reload these tables after resetting the parameter. For more information, follow the appropriate link at the end of this topic.

For versions earlier than version 4 PTF-2, the restriction regarding the 24:00:00 time value still exists. This means: IBM Db2 Analytics Accelerator for z/OS cannot process queries if the value 24:00:00 occurs in a TIME or TIMESTAMP expression, and table columns containing such values cannot be loaded into an accelerator-shadow table.

Related tasks

Switching from 24:00:00 conversion to native 24:00:00 support

If you have so far converted 24:00:00 time values to 23:59:59 by using the LOAD_ENABLE_HOUR24_CONVERSION configuration parameter and now want to use the native 24:00:00 support provided by newer versions of the Netezza Platform Software (NPS), you must remove this parameter or set it to the value false. In addition, you must reload accelerator-shadow tables that contain converted values.

DATE(numeric_exp) scalar function

During query routing to an accelerator, the DATE(numeric_exp) scalar function is converted to DATE(to_date('0000-12-31', 'YYYY-MM-DD')+trunc(numeric_exp)). If the numeric_exp result is a negative number, IBM Db2 Analytics Accelerator for z/OS adds BC to the date. An error is returned when the converted scalar function is evaluated in Db2.

Dates in TIMESTAMP expressions

If a date is supplied as the only argument to a TIMESTAMP expression, for example TIMESTAMP(DATE('2015-12-31')), Db2 for z/OS returns a timestamp with a time portion that shows no fractional seconds, whereas IBM Db2 Analytics Accelerator for z/OS returns fractional seconds with a precision of six digits:

| | |
|-------------------------------|----------------------------|
| Db2 for z/OS | 2015-12-31 00:00:00 |
| IBM Db2 Analytics Accelerator | 2015-12-31 00:00:00.000000 |

You can circumvent this problem by supplying the date as a string value, for example TIMESTAMP('2015-12-31') because this gives the same return value in both systems, that is:

```
2015-12-31 00:00:00.000000
```

Formats

- IBM Db2 Analytics Accelerator for z/OS does not support all date and time formats that Db2 supports. This might lead to different results for accelerated queries and inhouse Db2 queries if the VARCHAR_FORMAT or TIMESTAMP_FORMAT scalar function is used. The following formats are not supported by IBM Db2 Analytics Accelerator for z/OS:

- FF[n] - fractional seconds (000000-999999)

The optional number *n* is used to specify the number of digits to include in the return value. Valid values for *n* are the integers from 1-6. The default is 6.

- ID - ISO day of the week (1-7)

The value 1 represents Monday. The value 7 represents Sunday.

- IYYY - ISO year (0000-9999)

The last four digits of the year based on the ISO week that is returned.

- NNNNNN - microseconds (000000-999999)

This format is equivalent to FF6.

- RR - last two digits of the year (00-99)

- SSSSS - seconds since the previous midnight
- Db2 accepts an argument in the format `yyyynnn` as input for the DATE function. IBM Db2 Analytics Accelerator for z/OS does not accept this format and therefore issues an error.

Note: This restriction no longer exists with Netezza Platform Software (NPS) 7.2 or later.
- Similarly, Db2 accepts an argument in the format `yyyyxxddhhmmss` and also a 13-byte string as input for the TIMESTAMP function, whereas IBM Db2 Analytics Accelerator for z/OS does not. Queries that contain strings in these formats are routed to the accelerator none the less because Db2 bind time is unaware of this incompatibility. The string could be a valid TIMESTAMP string.

Strings and their conversion

For some scalar functions, such as TIME, Db2 accepts a time value, a timestamp, and also a string representation of times and timestamps. When Db2 evaluates the scalar function, it first checks whether a value can be interpreted as a time. If this fails, it tries to interpret the value as a timestamp. The corresponding accelerator functions do not accept string values. During query conversion, the content of a string is not evaluated. Instead, it is always cast to a time value. If the string represents a valid time format on the accelerator, IBM Db2 Analytics Accelerator for z/OS processes the query. Otherwise, if the string represents a timestamp, it returns an error. A workaround is to cast the string explicitly to a timestamp in the query.

Affected functions:

- CAST if the operation converts the string to a Db2 TIME value
- EXTRACT(HOUR FROM <arg>)
- EXTRACT(MINUTE FROM <arg>)
- HOUR
- MIDNIGHT_SECONDS
- MINUTE
- SECOND
- TIME

Incompatibilities related to IBM InfoSphere Change Data Capture for z/OS

You might encounter execution errors or deviating query results when you use the incremental update function. Some of these errors or result deviations are due to incompatibilities between Db2 for z/OS, IBM Db2 Analytics Accelerator for z/OS, and IBM InfoSphere Change Data Capture for z/OS. The following section deals with these incompatibilities.

IBM InfoSphere Change Data Capture for z/OS is the main software component behind the incremental update function of IBM Db2 Analytics Accelerator for z/OS.

All incompatibilities that are listed in the section *Incompatibilities between Db2 for z/OS and IBM Db2 Analytics Accelerator for z/OS* also apply to IBM InfoSphere Change Data Capture for z/OS.

In addition, incompatibilities that affect the regular load function of IBM Db2 Analytics Accelerator for z/OS (the `SYSPROC.ACCEL_LOAD_TABLES` stored procedure) also affect IBM InfoSphere Change Data Capture for z/OS. However, the following exceptions exist when IBM InfoSphere Change Data Capture for z/OS transfers data to IBM Db2 Analytics Accelerator for z/OS:

- Values of VARCHAR FOR MIXED and VARGRAPHIC columns that exceed 16000 characters are cut off when they are received by IBM Db2 Analytics Accelerator for z/OS. The difference to Db2 for z/OS is that in the case of IBM InfoSphere Change Data Capture for z/OS, *no warning or error message* is issued.
- In contrast to the handling of ideographic space characters (U+3000) coming from Db2 for z/OS, which are converted to U+0020 characters when they are received by the Netezza system, *no conversion* occurs when such characters are received from IBM InfoSphere Change Data Capture for z/OS. U+3000

characters remain unchanged when they are transferred to the Netezza database. This means that operations on the data in the Netezza database might not show the intended result. For example, an execution of the `trim` command will not remove leading or trailing spaces.

Restrictions of accelerator-only tables

Here is a summary of the restrictions that exist for accelerator-only tables.

Current limitations

The use of accelerator-only tables brings extra workloads to your accelerators that compete for the same resources, such as CPU, disk, and system memory. This might impact the stability of your production environment.

Data-definition (DDL) statements

The following restrictions exist for data-definition statements and accelerator-only tables:

- The `IN ACCELERATOR` clause can be used only once in a statement.
- A `CREATE TABLE` must not contain a materialized query definition if the table is an accelerator-only table.
- A `CREATE MASK` statement must not define a mask for an accelerator-only table.
- A `CREATE PERMISSION` statement must not define a column permission for an accelerator-only table.
- A `DECLARE GLOBAL TEMPORARY TABLE` statement must not reference an accelerator-only table.
- A `CREATE TRIGGER` or `ALTER TRIGGER` statement must not reference an accelerator-only table in the body of the trigger.
- A `CREATE TRIGGER` or `ALTER TRIGGER` statement with an `INSTEAD OF` clause must not reference a view that references an accelerator-only table in the body of the trigger.
- An `ALTER TABLE` statement is not allowed if the table is an accelerator-only table.
- An `ALTER TABLESPACE` statement is not allowed if the table space contains accelerator-only tables.
- A `DROP TABLESPACE` statement fails if the table space contains accelerator-only tables. You must first drop the accelerator-only tables by using a `DROP TABLE` statement.
- The `DROP DATABASE` statement does not behave as expected:
 - If you create an accelerator-only table without specifying a database, the table is created in the default database as usual, but a `DROP DATABASE` statement does not remove that database.
 - A `DROP DATABASE` statement does not remove a database and the tables therein if some of the tables are accelerator-only tables. To remove such a database, first remove all accelerator-only tables by using separate `DROP TABLE` statements, and then the database.
- A `RENAME TABLE` statement fails if the table is an accelerator-only table.
- A `LOCK TABLE` statement must not refer to an accelerator-only table.
- A `CREATE INDEX` statement fails if the table to be indexed is an accelerator-only table.
- A `CREATE SYNONYM` statement fails if the synonym is for an accelerator-only table.
- You cannot create more than one accelerator-only table in a single transaction. The following example does not work:

```
CREATE TABLE AOT1 ... IN ACCELERATOR ...
CREATE TABLE AOT2 ... IN ACCELERATOR ...
COMMIT;
```

This example, on the other hand, does work:

```
CREATE TABLE AOT1 ... IN ACCELERATOR ...
COMMIT;
CREATE TABLE AOT2 ... IN ACCELERATOR ...
COMMIT;
```

In addition, the following clauses or keywords cannot be used in DDL statements that refer to accelerator-only tables:

| | | | |
|--------------|----------------------------|----------------|---------------|
| APPEND | AS FULLSELECT ¹ | AUDIT | BUFFERPOOL |
| CHECK | COMPRESS | DATA CAPTURE | DSSIZE |
| EDITPROC | FIELDPROC | FOREIGN KEY | GENERATED |
| HASH | IMPLICITLY HIDDEN | IN TABLESPACE | INLINE LENGTH |
| LIKE | LOGGED | MEMBER CLUSTER | NOT LOGGED |
| PARTITION BY | PERIOD | PRIMARY KEY | TRACKMOD |
| UNIQUE INDEX | VALIDPROC | VOLATILE | WITH DEFAULT |

Other SQL statements

The following statements are not allowed:

- You cannot run an `INSERT INTO <accelerator-only table> SELECT ... FROM ...` statement if the `SELECT` part of the statement references a normal Db2 table that has no loaded counterpart on the accelerator. The statements succeeds only if the `SELECT` part references one or more tables on the same accelerator as the accelerator-only table.
- You cannot submit an `UPDATE` statement against table columns that serve as distribution keys.
- You cannot insert values directly into a decimal column of an accelerator-only table if these values are the result of a division where the dividend, the divisor, or both are decimals. However, the operation works if the division is part of the `SELECT` portion in an `INSERT INTO ... SELECT FROM ...` statement.

Restrictions on data types, column types, and code pages

Note that restrictions that apply to certain data types in general also apply to the use of these types in accelerator-only tables. In addition to that, the following restrictions exist for data types, column types, and code pages (CCSIDs), or are especially noteworthy:

- The column names in an accelerator-only table must not start with a tilde (~) followed by an underscore () character.
- You cannot have string columns of the type `CHAR FOR BIT DATA` or `VARCHAR FOR BIT DATA` in accelerator-only tables if these tables are encoded in ASCII or UNICODE. Only EBCDIC tables can have such columns.
- The `CHAR FOR BIT DATA` and `VARCHAR FOR BIT DATA` data types are not supported in accelerator-only tables if the environment has been set up for the use of mixed data (`ZPARM MIXED=YES`).
- You cannot define a large-object (LOB) column for an accelerator-only table.
- You cannot define a security label column for an accelerator-only table.

Stored procedures

Some of the IBM Db2 Analytics Accelerator stored procedures do not work on accelerator-only tables:

SYSPROC.ACCEL_ADD_TABLES

Submit a `CREATE TABLE ... IN ACCELERATOR` statement instead.

¹ The restriction for the `AS FULLSELECT` clause is limited to the `CREATE TABLE` statement. It does work with other statements that reference an accelerator-only table, such as the `CREATE VIEW` statement.

New features in Db2 10 for z/OS

Some features that were introduced with Db2 10 for z/OS are not yet supported by IBM Db2 Analytics Accelerator for z/OS.

General

The EXPLAIN reason codes that hint at routing errors in connection with new features in Db2 10 for z/OS are the codes 11, 15, and 17.

Reason code 11 covers unsupported expressions, data types, and so on, while reason code 15 is a general reason code for all errors that are not covered by reason code 11. Reason code 17 is returned if you try to process a query with an INSERT statement, but have not set the QUERY_ACCEL_OPTIONS parameter accordingly. For more information about the QUERY_ACCEL_OPTIONS parameter, see *Installing Db2 libraries with IBM Db2 Analytics Accelerator for z/OS support* in the *IBM Db2 Analytics Accelerator for z/OS: Installation Guide*

Access control of columns or rows

IBM Db2 Analytics Accelerator for z/OS handles columns with access control or Db2 tables with row access control as follows:

- Columns with access control are ignored when the corresponding accelerator-shadow table is loaded.
- Tables for which row access control has been defined cannot be added to an accelerator.
- If a query references a column for which a column mask has been activated, the query is not routed to an accelerator.

Cross-loading of tables

When a LOAD DATA INCURSOR ... INTO statement is used, the query inherits the setting of the CURRENT QUERY ACCELERATION special register. Hence queries are automatically routed to an accelerator if this has been enabled by the CURRENT QUERY ACCELERATION special register.

Cross-loading is not supported if the CURRENT GET_ACCEL_ARCHIVE special register is set. Hence queries with this setting cannot be accelerated in a cross-loading context.

CURRENT EXPLAIN MODE special register

Query routing to an accelerator works for queries that use the CURRENT EXPLAIN MODE special register if the special register is set to the value YES or EXPLAIN. Meaning of these settings:

CURRENT EXPLAIN MODE = YES

Enables the Db2 EXPLAIN facility and causes EXPLAIN information to be inserted into the EXPLAIN tables for eligible dynamic SQL statements after preparing and executing the statement. Dynamic SQL statements are hence compiled and executed normally.

CURRENT EXPLAIN MODE = EXPLAIN

Enables the Db2 EXPLAIN facility and captures EXPLAIN information for eligible dynamic SQL statement after preparing the statement. Note that with setting, a dynamic statement or query will not be executed, except for the SET clauses that it might contain.

Implicit casting

In Db2 10 for z/OS, string data types and numeric data types can be made compatible by an implicit casting of the string data type to the DECFLOAT data type. Because IBM Db2 Analytics Accelerator for z/OS does not support the DECFLOAT data type, queries containing such constructs cannot be routed to an accelerator.

New OLAP functions

IBM Db2 Analytics Accelerator for z/OS supports the following moving aggregate functions:

- AVG

- CORRELATION (see the **Notes**[®])
- COUNT
- COUNT_BIG
- COVARIANCE (see the **Notes**)
- COVARIANCE_SAMP (see the **Notes**)
- MAX
- MIN
- STDDEV
- SUM
- VARIANCE (VARIANCE_SAMP)

Notes:

- The moving aggregate functions CORRELATION, COVARIANCE, and COVARIANCE_SAMP are supported only if none of the arguments uses the DECFLOAT data type, which cannot be handled by IBM Db2 Analytics Accelerator for z/OS.
- The result data type that IBM Db2 Analytics Accelerator for z/OS returns for the CORRELATION, COVARIANCE, and COVARIANCE_SAMP functions is DOUBLE, and not DECFLOAT, as in Db2 10 for z/OS. This results in a loss of precision.
- Queries that use the previously mentioned moving aggregate functions are not accelerated if the window-aggregation-group clause specifies just a group-end clause, for example:

```
SELECT C1, C2, C3, SUM(C2)
OVER (ORDER BY C3 ROWS UNBOUNDED FOLLOWING)
FROM <table>
ORDER BY 1,2,3,4;
```

For a complete list of the new OLAP functions, see the Db2 10 for z/OS documentation.

Syntax

If a query contains syntactical constructs that are supported by Db2 10 for z/OS, but not Db2 Version 9.1 for z/OS, the query is not routed to IBM Db2 Analytics Accelerator for z/OS. For example, a query containing `TIMESTAMP(6)` will not be routed to an accelerator, although the construct delivers the same result as `CURRENT_TIMESTAMP`.

Temporal tables

Although tables that keep track of system time intervals and business time intervals (system-temporal tables, business-temporal tables, and bi-temporal tables) were introduced in Db2 10 for z/OS, IBM Db2 Analytics Accelerator for z/OS supports system-temporal tables and bi-temporal tables only in connection with *Db2 11 for z/OS*. Business-temporal tables, on the other hand, are also supported with Db2 10 for z/OS. Queries referencing temporal tables usually contain the following expressions or clauses:

- FOR SYSTEM_TIME AS OF
- FOR SYSTEM_TIME FROM ... TO ...
- FOR SYSTEM_TIME BETWEEN ... AND ...
- FOR BUSINESS_TIME AS OF
- FOR BUSINESS_TIME FROM ... TO ...
- FOR BUSINESS_TIME BETWEEN ... AND...

System-temporal and bi-temporal tables use columns with a timestamp data type that has a precision of 12 fractional seconds. On the accelerator, these timestamps are truncated, leaving a precision of only 6 fractional seconds. For that reason, you must enable the use of system-temporal and bi-temporal tables. To do so, set or include option 5 in the value of the `QUERY_ACCEL_OPTIONS` parameter or `ZPARM`.

Restriction: A *static* SQL query that includes a FOR SYSTEM_TIME ... or FOR BUSINESS_TIME ... is not routed to an accelerator if one of the following bind options (value YES, default) is used.

| Table 15. Unsupported bind options | |
|--|---|
| Clause | Bind option (value YES, which is the default) |
| <ul style="list-style-type: none"> • FOR BUSINESS_TIME AS OF • FOR BUSINESS_TIME FROM ... TO ... • FOR BUSINESS_TIME BETWEEN ... AND... | <ul style="list-style-type: none"> • BUSTIMESENSITIVE • BUSINESS_TIME SENSITIVE |
| <ul style="list-style-type: none"> • FOR SYSTEM_TIME AS OF • FOR SYSTEM_TIME FROM ... TO ... • FOR SYSTEM_TIME BETWEEN ... AND ... | <ul style="list-style-type: none"> • SYSTIMESENSITIVE • SYSTEM_TIME SENSITIVE |

In cases like this, you receive error message -4742 with reason code 18.

Timestamps

The portion that denotes fractional seconds in timestamps can have up to twelve digits in Db2 for z/OS, which means that even picoseconds can be represented. IBM Db2 Analytics Accelerator for z/OS, on contrary, only supports timestamps with a precision up to six digits (microseconds), and can handle incoming timestamps with a precision of 12, which are truncated to a length of six digits. This behavior reflects a limitation of the underlying Netezza database. To deal with a precision of 12, you must allow the truncation of such values by setting the QUERY_ACCEL_OPTIONS parameter or ZPARM to the value 6.

Be aware that the truncation of the fractional seconds portion has implications:

- The truncation leads to a loss of precision. Bear this in mind if timestamp precision is critical.
- A timestamp column might have been chosen as the primary key of a Db2 table because the high precision of the fractional seconds guarantees the uniqueness of the values. After a truncation, the values might not be unique anymore. Therefore, the very same column might be unsuitable as the primary key of an accelerator-shadow table.

Restrictions: The following constructs are not supported, no matter if truncation is enabled or not:

- Timestamps with timezone specifications, to the effect that:
 - SQL queries that require TIMESTAMP with a timezone specification as the result data type are not routed to an accelerator.
 - Timestamps with timezone constants are not accepted.
 - Functions and special registers that are related to timestamps with timezone specifications are not accepted.
- Fractional seconds with a precision greater than 6 in values of parameter markers
- Fractional seconds with a precision greater than 6 in CHAR columns that are referenced as part of an AS OF clause

Note: If a string constant or expression is used in connection with timestamps, such as string_col = timestamp_col, the query is routed to IBM Db2 Analytics Accelerator for z/OS regardless of the content of the string expression because the string constant or expression is not validated. This might cause a run-time error during query execution if the string column contains timestamp values with a precision other than 6.

For more information, see *Setting ZPARMs for IBM Db2 Analytics Accelerator for z/OS* in the *IBM Db2 Analytics Accelerator for z/OS: Installation Guide*.

Related concepts

[EXPLAIN information](#)

After creating the necessary EXPLAIN tables, you can analyze queries by invoking the Db2 EXPLAIN function. Such queries are accepted by regular and virtual accelerators alike. The analysis shows whether a query can be accelerated, indicates the reason for a failure, and gives a response time estimate. The outcome of the analysis can also be visualized in an access plan graph.

New features in Db2 11 for z/OS

See which new features in Db2 11 for z/OS are supported by IBM Db2 Analytics Accelerator for z/OS and which are not.

Global variables

Db2 11 for z/OS introduces the concept of global variables, which can be created, instantiated, accessed, and modified by applications. Global variables are named memory variables that you can access and modify through SQL statements. Global variables enable you to share relational data between SQL statements without the need for an application to transfer data. A global variable is associated with a specific application context, and contains a value that is unique to that application scope.

Global variables are not supported by IBM Db2 Analytics Accelerator for z/OS. A query that contains a global variable statement is hence not routed to an accelerator.

Furthermore, the following IBM Db2 Analytics Accelerator for z/OS special registers cannot be set to the value of a global variable:

- CURRENT_GET_ACCEL_ARCHIVE
- CURRENT_QUERY_ACCELERATION

Support for the array data type in SQL PL, CALL, and Java

An array consists of an ordered set of elements of a single built-in data type. Db2 11 for z/OS offers limited support for arrays within SQL to provide more options for routines and data access code.

Arrays can be defined as parameters and variables for SQL routines. In addition, arrays can be passed from one procedure to another as arguments for the **IN** and **OUT** parameters, function parameters, or as a function return value. Db2 11 for z/OS supports both, ordinary arrays and associative arrays. Ordinary arrays have a defined upper limit, while associative arrays do not have such a limit. When the array data type is used in a query, the query is not routed to an accelerator.

Aliases and synonyms

An alias is an alternative name for an object such as a Db2 table, a Db2 view, or another Db2 alias. It can be used to reference an object wherever that object can be referenced directly. Synonyms are similar to aliases, but are supported only for compatibility with previous releases. Synonyms will be deprecated in a future release. Db2 11 for z/OS extends the support for aliases so that these can be defined for sequence objects, and also provides support for *public aliases*. This product does not support aliases if these are used in a sequence object.

SQL grouping sets and supergroups

A grouping-sets specification allows multiple grouping clauses to be specified in a single statement. This can be thought of as the union-all of two or more groups of rows into a single result set.

It is logically equivalent to the union-all of multiple subselects with the GROUP BY clause in each subselect corresponding to one grouping set. A grouping set can be a single element or can be a list of elements delimited by parentheses and commas, where an element is either a grouping-expression or a supergroup. Grouping sets allow the computing of groups with just a single pass over the base table.

A supergroup stands for a ROLLUP clause, a CUBE clause, or a grand-total clause. Db2 11 for z/OS also introduces a new aggregate function named GROUPING. This function is used in conjunction with grouping sets and supergroups to return a value that indicates whether a row that is returned in a GROUP BY answer set is a null value generated by a grouping set.

Starting with this version of IBM Db2 Analytics Accelerator for z/OS (version 5.1.0), grouping sets are supported.

Differences in floating-point error tolerances

For queries that involve floating-point aggregates, you can expect IBM Db2 Analytics Accelerator for z/OS to produce results that are different from those delivered by inhouse Db2 for z/OS processing.

Reason

You know that the same query processed twice by Db2 for z/OS can give you different results. This is due to the fact that the results depend on the order in which the rows or tuples are processed. It is not possible to determine the order that Db2 will choose beforehand.

In the case of IBM Db2 Analytics Accelerator for z/OS, another sort of result deviation occurs, which is caused by the different methods of representation for floating-point numbers. Db2 for z/OS uses hexadecimal floating-point (HFP) numbers, whereas IBM Db2 Analytics Accelerator for z/OS uses IEEE754 floating-point numbers.

When a query is routed from Db2 for z/OS to IBM Db2 Analytics Accelerator for z/OS, all processing takes place on the accelerator.

The main difference between these two methods is the base or radix of the exponential part. HFP uses a base of 16. IEEE754 uses a base of 2. The base of 16 requires the exponent of HFP numbers to be increased in steps of 4 during the calculation of an aggregate. IEEE754 numbers, on the other hand, need to be increased just in steps of 1. The multiplier in front of the exponent (mantissa) of an HFP number loses 4 bits at the right end each time the exponent is increased. The mantissa of IEEE754 numbers loses just 1 bit. The difference in error thus lies in the difference of three bits, and the amount per step depends on the values of these. If the values of the three bits are all zero, the error difference is also zero. If all values are 1, the difference in error is maximized. Because of the lower exponential increase per step, IEEE754 is the more precise method of representation.

Whether the difference in precision matters much mainly depends on the number of rows or tuples (n) used for floating-point aggregates. Naturally, if n gets higher, the result deviation or error increases, too. How high the total deviation will be is hard to quantify as it further depends on the type of the mathematical function that is used (compare, for example, a simple addition with an operation that takes the square of each number involved).

Important: In contrast to HFP numbers of the type REAL in Db2 for z/OS, which might range from $-7.2E+75$ to $+7.2E+75$, IEEE754 is only capable of processing REAL floating point numbers between $-3.4E+38$ and $3.4E+38$. This means that it is not possible to load an accelerator-shadow table with REAL values outside the range of $-3.4E+38$ to $3.4E+38$.

Also bear in mind that HFP and IEEE754 have different minimum and maximum values for REAL and DOUBLE numbers:

| | HFP (Db2 for z/OS) | | IEEE754 (IBM Db2 Analytics Accelerator for z/OS) | |
|---------------|--------------------|--------|--|--------|
| | REAL | DOUBLE | REAL | DOUBLE |
| Min. | | | | |
| Max. | | | | |
| Min. positive | | | | |
| Max. negative | | | | |

Chapter 4. Administration clients

Different administration clients are available for the administration of the product: IBM Db2 Analytics Accelerator Studio and IBM Data Server Manager.

IBM Db2 Analytics Accelerator Studio is a plugin for IBM Data Studio, which allows you to administer IBM Db2 Analytics Accelerator for z/OS. IBM Data Studio is a classic workstation application, in the sense that it must be installed on all client workstations connecting to your data server.

IBM Data Server Manager is a multi-purpose web application, which can also be used to administer IBM Db2 Analytics Accelerator for z/OS. Because it is a web application that comes with its own web server, it is sufficient to install it on a single computer within your company network. As long as client workstations can connect to this computer over the network, they can use IBM Data Server Manager for the administration of IBM Db2 Analytics Accelerator for z/OS.

IBM Data Server Manager is easier to maintain because updates must be installed in one place only, and need not be rolled out to a number of client workstations.

Instead of using one of the supported administration clients, you can also control and operate the product by using Db2 commands and the stored procedures that come with the product.

Launching a function from an administration client causes the client to connect to your data server, which in turn calls a stored procedure that executes the corresponding command on the accelerator. The accelerator is thus always controlled and maintained indirectly via the data server.

In most cases, you do not have to change existing database applications to use IBM Db2 Analytics Accelerator. If an accelerator has been properly deployed and tables have been added to the accelerator, queries that come from database applications are usually routed automatically from your data server to the accelerator provided that this results in shorter response times.

See the following diagram:

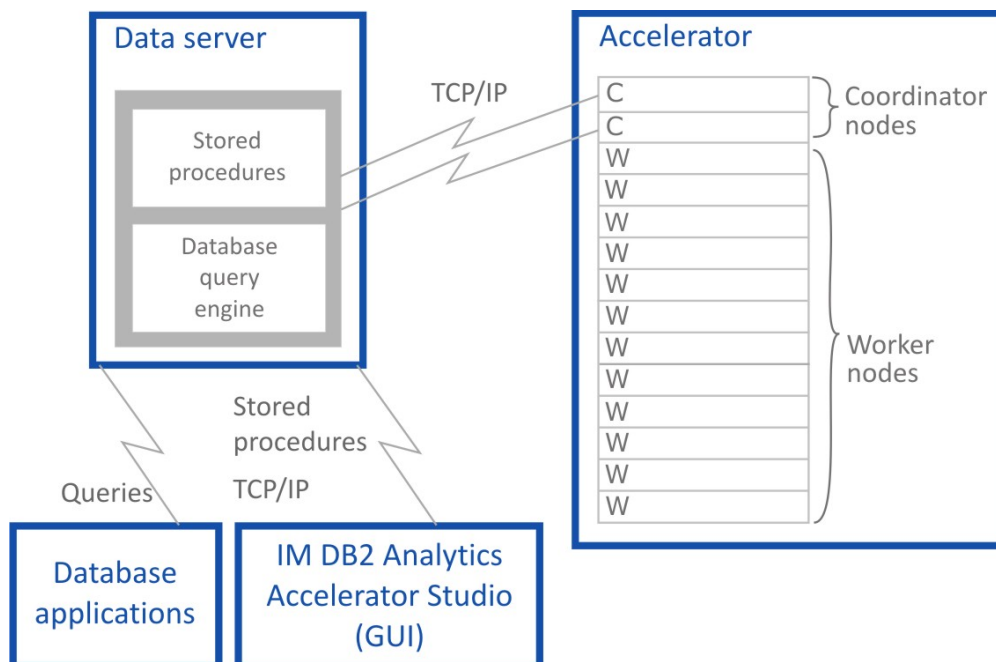

Figure 4. IBM Db2 Analytics Accelerator setup

Interface elements of IBM Db2 Analytics Accelerator Studio

Here is a brief description of the interface elements that show IBM Db2 Analytics Accelerator Studio functionality.

Note: When you start IBM Db2 Analytics Accelerator Studio for the first time, you see the **Welcome** screen. To see the main window of IBM Db2 Analytics Accelerator Studio with the principal functions and controls, just close the **Welcome** screen by clicking the cross-shaped icon on the tab of the **Welcome** screen (usually positioned on the upper left).

Menu bar

When IBM Db2 Analytics Accelerator Studio has been opened, specific menus or menu choices are added to the menu bar of the Accelerator perspective. In addition, some standard menu choices of the Data perspective might have a different effect when IBM Db2 Analytics Accelerator Studio is loaded.

Edit > Select All

Selects all elements in the currently active view.

Window > Open Perspective > Other > Accelerator

Opens the Accelerator perspective, which shows IBM Db2 Analytics Accelerator Studio (if it has been installed).

Window > Reset Perspective

Restores all default views of IBM Db2 Analytics Accelerator Studio to their default size and position in the IBM Data Studio main window.

Window > Show View

Opens a submenu that allows you to reopen a currently closed IBM Db2 Analytics Accelerator Studio view.

Help > Welcome > Overview > IBM Db2 Analytics Accelerator Studio

Opens the *Introduction* topic in the online help system.

Help > Welcome > First Steps > Demonstration Videos

Opens the *Demonstration videos* topic in the online help system, which lists the available videos. Clicking a link starts the playback of a video.

Help > Welcome > Workbench

Closes the **Welcome** screen and displays the main view of IBM Db2 Analytics Accelerator Studio.

Administration Explorer

The **Administration Explorer** shows your database connection profiles and various objects like schemas, tables, and stored procedures that are defined in the database catalogs of your data servers.

The **Administration Explorer** is the navigation tree that you can see in [Figure 5 on page 59](#). It is usually located on the left-hand side.

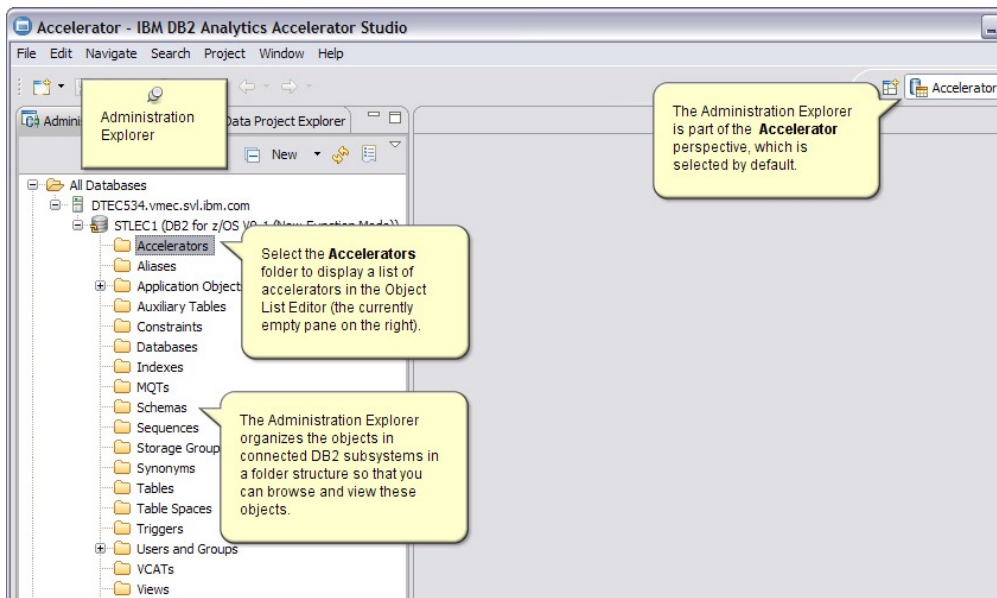

Figure 5. Administration Explorer

Menus

Depending on your selection in the **Administration Explorer**, the menu (right-click action) offers the following menu choices specific to IBM Db2 Analytics Accelerator for z/OS:

An existing database connection profile

When you right-click an existing database connection profile, you can select the following items from the menu:

Connect

Connects to the database that is referred to in the profile. You are asked for the password of the logon user if the option **Save password** is not selected in the profile.

Disconnect

Disconnects an active database connection.

Ping

Issues a **ping** command to check whether the network connection to the database server works.

Manage Connection

Gives you access to a submenu from which you can rename, delete, or copy (duplicate) the selected profile.

Properties

Opens the **Properties** sheet of the existing profile so that you can edit it.

Folders

When a database server has been connected to, you can see the various objects on that server, which are organized in folders. Most folders pertain to database objects that are created or configured in Db2 for z/OS. An exception is the **Accelerators** folder, which pertains to IBM Db2 Analytics Accelerator for z/OS only.

Accelerators folder

Selecting the **Accelerators** folder opens the **Object List Editor** in the main view (pane on the right).

The context menu of the **Accelerators** folder offers the following choices:

Add Accelerator

Starts the **Add Accelerator** wizard, which allows you to add an accelerator to the system configuration.

Add Virtual Accelerator

Starts the **Add Virtual Accelerator** wizard, which allows you to add a virtual accelerator to the system configuration.

Important: Virtual accelerators are a feature of earlier versions of IBM Db2 Analytics Accelerator for z/OS. They are not supported by IBM Db2 Analytics Accelerator for z/OS Version 7.

Save Trace

Opens the **Save Trace** window, in which you can select the trace information that you want to save and either save it to a file or submit it to IBM.

Refresh

Refreshes the list of accelerators in the Object List Editor (right pane).

Object List Editor

Apart from various other functions, the Object List Editor contains a table with an entry for each accelerator that has been configured. The **Object List Editor** opens when you select the **Accelerators** folder in the **Administration Explorer**.

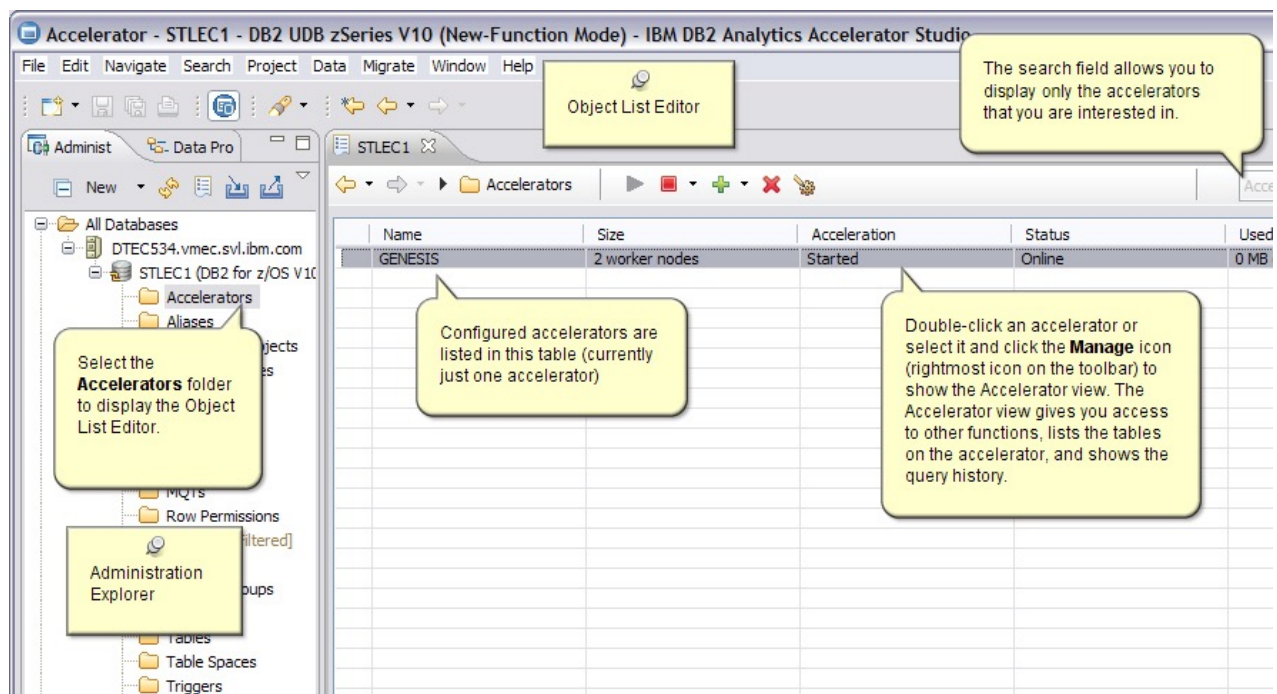

Figure 6. Object List Editor

Buttons in the Object List Editor

On top of the table in the **Object List Editor**, you find the following buttons:



The arrow pointing to the left returns to the previous display in the **Object List Editor**.

The downward-pointing arrow allows you to select a particular earlier display from a list.



To switch forward to a display in the Object List Editor that was opened later than the current one.

The downward-pointing arrow allows you to select a particular later display from a list.

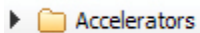
 Accelerators

To change the type of object that is currently displayed in the Object List Editor. The currently selected type is displayed to the right of the twistie (here: accelerators).



To enable the selected accelerator in Db2 for z/OS.

Notes:

- Multiple selections are not possible here. You can enable only one accelerator at a time.
- If the accelerator is attached to a Db2 data sharing group, acceleration is enabled for all members of the group.



To disable the selected accelerator in Db2 for z/OS.

The downward-pointing arrow on the right opens a menu from which you can select the following choices:

Stop

Same as clicking the button on the toolbar

Stop Force

A function that disables the selected accelerator immediately, that is, without waiting for the completion of not yet finished queries.

Notes:

- Multiple selections are not possible here. You can disable only one accelerator at a time.
- If the accelerator is attached to a Db2 data sharing group, acceleration is disabled for all members of the group.



To open the **Add Accelerator** wizard. See the previous description for the context menu of the Accelerators folder.

The downward-pointing arrow on the right opens a menu from which you can select the following choices:

Add Accelerator

Same as clicking the button on the toolbar

Add Virtual Accelerator

Starts the wizard for adding a virtual accelerator



To remove the selected accelerator from the system configuration.

Note: Multiple selections are not possible here. You can remove only one accelerator at a time.



To open the **Accelerator** view for the selected accelerator, in which you can define, remove, enable, or disable accelerator-shadow tables and invoke various other functions.

Clicking this button has the same effect as double-clicking an accelerator name in the table of the **Object List Editor**.

Note: Multiple selections are not possible here. You can only open the **Accelerator** view for one accelerator at a time.



To open the monitoring view for the selected accelerator. The monitoring view offers graphical displays of various usage metrics, such as the system utilization, the number of parallel tasks running on an accelerator, the disk space occupied by the data on the accelerator as claimed by the connected Db2 subsystems, as well as the replication throughput and the replication latency.

The icon with the downward-pointing arrow allows you to select a trace file that contains these usage metrics, so that the data in the trace file is presented graphically.

The search field makes it easier to find particular accelerators if the list is long. Type the names of accelerators in this field, either fully or partially and press Enter. The table will display just those accelerators bearing or starting with that name.

Column information

The table in the **Object List Editor** provides various information about the accelerators, such as:

Name

Name of an accelerator

Size

Size of an accelerator, that is, its number of worker nodes (3, 6, or 12).

Acceleration

Whether acceleration has been *started* or *stopped* for the Db2 subsystem that is associated with an accelerator.

Note: The status of an accelerator cannot not been determined if acceleration has been stopped for a Db2 subsystem.

Status

Current[®] status or state that an accelerator is in. The following states are possible:

Cluster Is Initializing

Interim state that is shown when a new software version is applied. When this process has finished, the accelerator goes to *Fully Operational*.

Fully Operational

Ready to be enabled in Db2 for z/OS.

Online

Ready for processing.

Running

The accelerator is processing queries.

Stopping

Interim state that is shown when you click the **Stop** button or issue the **STOP -ACCEL** command from Db2 for z/OS. During the *Stopping* phase, already started queries are completed.

Stopped

The accelerator is currently disabled in Db2 for z/OS.

Unknown

The current status of the accelerator cannot be determined.

Used Space

Overall size of the accelerator-shadow tables on an accelerator

Active Queries

The number of queries that is currently being processed on an accelerator

Replication

Indicates whether the incremental update function is enabled for this accelerator in the Db2 subsystem. Possible values:

Disabled

The incremental update function has not been configured for this accelerator and is therefore not available.

Configured

The incremental update function is available for this accelerator, but accelerator-shadow tables have not yet been added to the process.

Error

The incremental update function has been configured, but cannot be started due to an error.

Started

The incremental update function is running and updates are applied to accelerator-shadow tables that have been included in the process.

Stopped

The incremental update function is available and accelerator-shadow tables have been included in the process. However, the function is not running right now.

Accelerator views

To show the tables on an accelerator, view the query history, or access various other functions, double-click an accelerator name in the **Object List Editor**, which opens the related **Accelerator** view.

Accelerator view for regular accelerators

Here is a brief description of the status information and the function buttons on the **Accelerator** view for regular accelerators.

The screenshot shows the IBM Db2 Analytics Accelerator Studio interface. The main window is titled "Accelerator - Connection Profile: STLEC1 - Accelerator: VMNPS01 - IBM DB2 Analytics Accelerator Studio". The interface is divided into several sections:

- Administration Explorer:** A tree view on the left showing the database structure, including Databases, Indexes, MQTs, Row Permissions, Schemas, Sequences, Storage Groups, Synonyms, Tables, Table Spaces, Triggers, Users and Groups, VCATs, Views, and XML Schemas.
- Accelerator: VMNPS01 @ STLEC1:** The main view showing status information and functional links.
 - Status:** Acceleration: Started [Stop](#); Credentials valid since: 9/16/12 6:58 PM [Update](#); Status: Online; Trace: DEFAULT / OFF [Configure](#) [Save](#) [Clear](#); Used space: 8 MB of 191 GB; Active queries: 0.
 - Query Statistics:** Statistics collected since accelerator server process was started. Successful queries: 1; Maximum queue wait time: 0.453 seconds; Maximum number of queries in queue: 0; Failed queries: 0; Average queue wait time: 0.06 seconds.
 - About:** z/OS Stored Procedures: 3.1.0.20120822-1819; Server Accelerator version: 3.1.0.201209030518 [Transfer updates](#) [Remove](#) [Apply other software version](#); Netezza version: 6.0.8-0.F-1.P-0.Bld-24809; Client Studio: 3.1.0.201209110331 [Check for Updates](#).
- Tables (8 of 8 tables):** A table listing the tables on the accelerator, sorted by schema. The table has columns: Name, Size, Rows, Acceleration, Last Load, and Distribution Key.

| Name | Size | Rows | Acceleration | Last Load | Distribution Key |
|----------|------|--------|--------------|-----------|------------------|
| TPCH | 9 MB | - | 8 of 8 | - | - |
| CUSTOMER | 1 MB | 1,500 | Enabled | - | Random |
| LINEITEM | 3 MB | 60,175 | Enabled | - | Random |
| NATION | 1 MB | 25 | Enabled | - | Random |
| ORDERS | 1 MB | 15,000 | Enabled | - | Random |
| PART | 1 MB | 2,000 | Enabled | - | Random |
- Query Monitoring:** A section for viewing query history. It includes a "Show SQL..." button and a table of query results.

| SQL Text | User ID | Start Time | State |
|------------------------------------|---------|--------------------|------------|
| select count(*) from tpch.lineitem | SYSADM | 9/16/12 7:07:47 PM | Successful |

Yellow callout boxes provide additional information:

- "Accelerator view for regular accelerators" points to the main view title.
- "Links to various other functions" points to the [Configure](#), [Save](#), and [Clear](#) buttons.
- "Statistics about query execution" points to the Query Statistics section.
- "Links to various other functions" points to the [Transfer updates](#), [Remove](#), and [Apply other software version](#) buttons.
- "Tables on the accelerator (sorted by schema)." points to the table header.
- "Tables can be enabled or disabled, that is, included or excluded from acceleration." points to the "Acceleration" column.
- "Query history. Double-clicking an entry shows the SQL code." points to the Query Monitoring table.

Figure 7. Accelerator view for regular accelerators

Status information and functional links

The header of the **Accelerator** view for regular accelerators contains status information and links to related functions.

Table 17. Header information

| Label | Description |
|--------------------------------|---|
| Acceleration | <p>Whether the accelerator is currently enabled in Db2 for z/OS. To change the current status, click Start or Stop.</p> <p>If the accelerator is attached to a Db2 data sharing group, the behavior is different. The status <i>Started</i> is displayed if acceleration has been started for at least one member of the data sharing group. Other statuses are shown only if the status is the same for all members of the data sharing group. If the status of individual members is different, a warning icon is displayed.</p> <p>If you move the mouse pointer over the displayed status or the warning icon, a pop-up window shows the acceleration status for all members of the data sharing group.</p> <p>An additional functional link labeled Change is displayed for data sharing groups. Clicking it opens a window in which you can change the acceleration status of each member in the data sharing group.</p> |
| Status | <p>The status of the accelerator hardware.</p> <p>If the accelerator is attached to a Db2 data sharing group, you can move the mouse pointer over the status information to display the status of each member in the data sharing group.</p> |
| Used space | <p>The amount of disk space that is taken up by the tables, in proportion to the available space on the accelerator.</p> <p>This is the space allocated in the file system of the accelerator for the table spaces of the connected Db2 subsystem. Currently, these table spaces can only grow. So if you have removed tables from the accelerator that have used space before, then this size is a high watermark that may include free space in the table spaces for this subsystem. This free space can be reused when you add additional tables from this Db2 subsystem to the accelerator or when existing tables grow. However, the free space cannot be used by other Db2 subsystems paired with the same accelerator because these Db2 subsystems have their own table spaces. The free space can be given back to the operating system when you remove the pairing between the current Db2 subsystem and the accelerator. This action will remove the table spaces for this subsystem.</p> |
| Replication | <p>Only visible if incremental updates are configured. A status of Started indicates that the incremental update process is running for tables included in the process. Stopped indicates that the incremental update process has been suspended. To change the current status, click Start or Stop.</p> |
| Credentials valid since | <p>Shows the date on which the last authentication of the accelerator took place. To renew the authentication, click Update.</p> |
| Encryption details | <p>If you click the Encryption details, the Encryption Details window opens, which shows information about the use of encryption for the selected accelerator. This includes the status of hard-disk encryption, the status of encryption of data in motion, a list of encrypted IPsec tunnels (IP connections), and a list of the certificates that are used.</p> |
| Trace | <p>Shows the trace profiles for the accelerator and the stored procedures that are currently in use. To change a profile, click Configure. To change the settings for the saving of trace information to a file, click Save. To delete the trace information that has been collected, click Clear.</p> <p>Note: The Clear option is not available for cloud accelerators.</p> |

Table 17. Header information (continued)

| Label | Description |
|-----------------------|---|
| Active queries | The number of accelerated queries that are currently being processed. In parentheses, you see the number of queued queries. |

Table 17. Header information (continued)

| Label | Description |
|----------------------------|--|
| Replication latency | <p>Only visible if incremental updates are configured. This is not the case in Figure 7 on page 64. The value indicates how much the incremental update function is lagging behind. Possible values:</p> <p>Stopped Incremental updates have been stopped for the entire accelerator.</p> <p>Low It will take less than three minutes to propagate recent changes to the corresponding accelerator-shadow tables.</p> <p>Medium Recent changes to the original Db2 tables will be propagated to the corresponding accelerator-shadow tables within three and six minutes.</p> <p>High It will take six minutes or longer to apply recent changes to Db2 tables to the corresponding accelerator-shadow tables.</p> <p>See Note on replication latency.</p> <p>When you move the mouse pointer over the latency value in IBM Db2 Analytics Accelerator Studio, a pop-up window shows the following information:</p> <p>Target Agent Operations completed by the incremental update function.</p> <p>Inserts Number of row inserts in accelerator-shadow tables that have been included in the incremental update process.</p> <p>Deletes Number of row deletions from accelerator-shadow tables that have been included in the incremental update process.</p> <p>Restriction: This feature is currently not included in IBM Data Server Manager.</p> <p>Remember:</p> <ul style="list-style-type: none"> • An UPDATE is a DELETE followed by an INSERT, so these two figures account for all incremental updates that have been applied. • Since an UPDATE in Db2 is a DELETE followed by an INSERT on the accelerator side, the values can be different from those in Db2 for z/OS (see Source Agent). Furthermore, multiple operations on a single row within a short time might be reported as just one single operation. • If a load operation is in progress and lock mode Row has been selected, the original Db2 tables are not locked during the load. Hence it is possible to INSERT new rows into the Db2 tables even though a load is taking place. If incremental updates are enabled for the same tables, the incremental update function stores these new rows in the spill queue until the load has finished, and applies these changes thereafter (draining the spill queue). In the course of a drain, a DELETE and an INSERT operation is carried out for each row in the affected accelerator-shadow tables. The DELETE deletes the row that was inserted by the previous load operation, and the INSERT adds this row again (applies the latest change) . This has the effect that the number of Deletes increases in cases like this. <p>Clicking Show events opens the event viewer, which keeps a record of all transactions that are related to incremental updates.</p> |

Note on replication latency: The *replication latency* is disclosed through different channels, at different points in time. Sometimes, it is calculated by different systems. Values are reported:

- In the **Accelerator** view as described in the previous table
- When you run the Db2 command `-DIS ACCEL(<name>) DETAIL`
- In trace files:

```
<Event id="61098" timestamp="2018-11-28 18:07:51" level="W" addressee="0" >
  The current replication latency of XXXXs on DB2 location ADB2K04 (subscription
  DWE9PLVY)
  has exceeded the threshold of 3600s.
</Event>
```

- In the status monitoring counter Q8STCRL
- As a result of running the SYSPROC.ACCEL_CONTROL_ACCELERATOR stored procedure in connection with the `<getAcceleratorInfo>` parameter.

These systems or reporting channels are not synced, so deviating values are inevitable. Deviations can be considerable, depending on the channel that is tapped and on the time when this is done. Stick to one reporting channel if you need to compare latency values.

| Table 18. Header information (continued) | |
|--|---|
| Label | Description |
| Replication latency (continued) | <p>Source Agent Number of data changes to relevant Db2 for z/OS tables (tables for which accelerator-shadow tables have been defined and that are included in the incremental update process.)</p> <p>Inserts Number of row inserts in the relevant Db2 for z/OS tables.</p> <p>Updates Number of updates to rows in the relevant Db2 for z/OS tables.</p> <p>Deletes Number of row deletions from the relevant Db2 for z/OS tables.</p> <p>Latency Repetition of the Replication latency value.</p> <p>Clicking Show events opens the event viewer, which keeps a record of all transactions that are related to incremental updates.</p> |

Monitoring

The **Monitoring** section provides the following information:

| Table 19. Information in the Monitoring section | |
|--|---|
| Label | Description |
| Queries | <p>Metrics related to queries since the start of the currently viewed accelerator, divided into the following categories:</p> <p>Successful Number of queries that ran successfully</p> <p>Failed Number of queries that failed</p> |

Table 19. Information in the **Monitoring** section (continued)

| Label | Description |
|-----------------|---|
| Queue | <p>Metrics related to queuing since the start of the currently viewed accelerator:</p> <p>Max. length The highest number of queries in the queue, up to this time.</p> <p>Important: The Max. length and Max. wait time values cover all system transactions during a given period of time. This includes internal system queries, as well as INSERT, UPDATE, and DELETE operations. Therefore, these fields might display positive values even if there have been no active user queries recently. A discrepancy becomes noticeable when you compare the values with the ones reported in the query history, which provides the same information for individual queries.</p> <p>Avg. wait time Average time that queries had to stay in the queue. The basis for the calculation is all queries that were processed during the last minute.</p> <p>Max. wait time Longest time that a query stayed in the queue, that is, before it was processed.</p> |
| CPU Cost | <p>CPU time that was used since the start of the currently viewed accelerator, with regard to the connected Db2 subsystem. The total CPU time is divided into the following categories:</p> <p>Query execution CPU time needed for query processing</p> <p>Data maintenance CPU time needed for load and High Performance Storage Saver operations</p> <p>Replication CPU time needed for incremental updates</p> |

About

The following information is displayed in the **About** section:

Table 20. Information in the **About** section

| Label | Description | Information blocks | Description |
|-------------|--|--------------------------|--|
| z/OS | Information about components on the z/OS data server | Stored procedures | The currently installed version of the IBM Db2 Analytics Accelerator stored procedures |

Table 20. Information in the **About** section (continued)

| Label | Description | Information blocks | Description |
|---------------|---|---|--|
| Server | Information about software components that are installed on the IBM PureData System for Analytics | Accelerator server | The version of the IBM Db2 Analytics Accelerator for z/OS software that is currently in use. To transfer an update package from the z/OS UNIX file system (zFS) on z/OS to the accelerator, click Transfer updates . To remove an obsolete version no longer used, click Remove . To use a different version of the IBM Db2 Analytics Accelerator for z/OS software, click Apply other software version . Note: The Transfer updates , Remove , and Apply other software version options are not available for cloud accelerators. |
| | | Netezza Performance Server (NPS) | The current version of the Netezza Platform Software (NPS). Before you install a new version of the Netezza Platform Software (NPS), make sure that the required minimum versions of the Netezza Firmware (FDT) and the Netezza Host Platform (HPF) are installed. To transfer an update package from the z/OS UNIX file system (zFS) to the IBM PureData System for Analytics, click Transfer updates . |
| | | Netezza Firmware (FDT) | Only visible if version 4 or later of the IBM Db2 Analytics Accelerator for z/OS is installed on the accelerator. This is the current version of the Netezza Firmware and Diagnostics and Tools (FDT) running on the accelerator (IBM PureData System for Analytics). To transfer an FDT update package from the z/OS UNIX file system (zFS) to the IBM PureData System for Analytics, click Transfer files . The installation of the Netezza Firmware (FDT), however, must be carried out by a service engineer and requires a downtime of the IBM PureData System for Analytics. |

Table 20. Information in the **About** section (continued)

| Label | Description | Information blocks | Description |
|---------------------------------|--|------------------------------------|---|
| Server (continued) | | Netezza Host Platform (HPF) | <p>Only visible if version 4 or later of the IBM Db2 Analytics Accelerator for z/OS is installed on the accelerator. This is the current version of the Netezza Host Platform (HPF) running on the accelerator (IBM PureData System for Analytics). The HPF software contains kernel updates, firmware, and other special software used by the Netezza host servers.</p> <p>To transfer an FDT update package from the z/OS UNIX file system (zFS) to the IBM PureData System for Analytics, click Transfer files. The installation of the Netezza Host Platform (HPF), however, must be carried out by a service engineer and requires a downtime of the IBM PureData System for Analytics.</p> |
| | | Access Server | <p>Only visible if incremental updates are configured. This is the version of the CDC Access Server, the central component in the incremental update process which manages the list of subscriptions (incremental update requests) and controls the agents involved in the process.</p> |
| | | Replication engine | <p>Only visible if incremental updates are configured. This is the version of the CDC Apply Agent, which propagates data changes to the IBM PureData System for Analytics, according to the instructions received from the CDC Access Server.</p> |
| Client | Information about your IBM Db2 Analytics Accelerator Studio installation | Studio | <p>The currently installed version of IBM Db2 Analytics Accelerator Studio. Click Check for Updates to look for a newer version.</p> |
| Optional Server Packages | <p>If external packages (remote stored procedures) are installed, the package name is shown here (for example: <i>IBM Netezza Analytics</i>). In addition, functional links are displayed to enable or disable the package for the selected accelerator.</p> | | |

Tables

The **Tables** section in the **Accelerator** view for regular accelerators contains buttons and a listing of the tables on the accelerator.

| <i>Table 21. Buttons in the Tables section</i> | |
|---|---|
| Button | Description |
| Add | Starts the Add Tables wizard. |
| Alter Keys | Opens a window in which you can select or change the distribution and organizing keys that are used by the accelerator. |
| Remove | Removes the selected tables from the accelerator. |
| Load | Opens the Load Tables window, in which you can select accelerator-shadow tables for loading and set the lock scope for the load process. |
| Acceleration | Opens a pull-down menu, from which you can enable or disable the selected accelerator-shadow tables so that these are included or excluded from query acceleration. |
| Storage Saver | <p>Allows you to archive partitions on an accelerator or restore these to their original locations. The button opens a menu with the following choices:</p> <p>Move Partitions to Accelerator Opens the Move Storage Saver Partitions to Accelerator window, which allows you to select Db2 for z/OS tables or partitions in order to archive the data therein on the accelerator currently viewed.</p> <p>Restore Partitions to Db2 Opens Restore Storage Saver Partitions to Db2 window, in which you can select accelerator-archive tables and partitions that have been archived on the currently selected accelerator in order to restore these.</p> |
| Replication | Only visible if incremental updates are configured. This is not the case in Figure 7 on page 64 . Clicking the button opens a pull-down menu from which you can enable or disable incremental updates for selected accelerator-shadow tables. |
| List Tasks | Opens the List Tasks window, which displays the running tasks on the currently viewed accelerator, such as table load processes. To cancel a running task, select it in the list and click Cancel Selected Task . |





| <i>Table 22. Icons and columns in the table of tables</i> | |
|---|---|
| Item | Description |
|  | Icon representing the schema of a table |
|  | Icon representing a table schema with not yet synchronized changes. It is shown if, for example, columns have been added to a Db2 for z/OS table that are not yet part of the corresponding schema definition on the accelerator. |
|  | Icon representing an accelerator-only table |
|  | Icon representing an accelerator-shadow table |
|  | Icon representing a table with not yet synchronized changes. It is shown if, for example, columns have been added to a Db2 for z/OS table, but not yet to the corresponding schema accelerator-shadow table. |

Table 22. Icons and columns in the table of tables (continued)

| Item | Description |
|--------------------------------|---|
| Name | Column containing the table names |
| Size | <p>Column containing the table sizes.</p> <p>If rows have been deleted from the table (for example by replication or by a partial reload), a certain space on the pages might remain empty. So if you run many data maintenance jobs on a table, such as replication, without ever reloading the table fully, the table might still grow over time, even if the overall number of rows does not change.</p> |
| Acceleration | Column that shows whether acceleration is enabled for a table |
| Last Load | Column that shows the timestamp of the last successful load for each table or the current table state. Because accelerator-only tables are not loaded by IBM Db2 Analytics Accelerator functions, the column always shows the table state (for example <i>AOT ready</i>) for this type of table. |
| Storage Saver Partition | <p>Column that provides information about the archived partitions of a table. The column is visible only if tables with archived partitions exist.</p> <p>At the schema level, the column shows how many partitions out of the total number of partitions were archived. At the table level, it shows the compressed data size of the archived partitions and the number of rows in these partitions. If archiving is in progress for a partition, the columns shows <i>In Progress</i>.</p> |
| Replication Since | <p>Column that shows the last incremental-update capture-point (a timestamp) for incrementally updated accelerator-shadow tables or <i>Disabled</i> for the tables that are not updated in that way.</p> <p>If continuous incremental updates are enabled, the column shows <i>Suspended</i> when a table load has started and incremental updates are therefore on halt, and <i>Refreshing</i> when table changes are being applied, be this through the ongoing load process or the draining of incremental updates from the spill queue.</p> |
| Distribution Key | Column that shows <i>Random</i> if random distribution is used or the names of distribution-key-columns if a distribution key is used. |
| Skew | Column that shows the skew value for each table on the accelerator. The skew value is a metric for the distribution imbalance of table rows across the snippet-processing units (SPUs) or worker nodes. The value is the difference between the smallest and the largest data slice for a table in megabytes (MB). |
| Organizing Keys | Column that shows the names of the organizing keys (column names) that were selected for a table. |

Table 22. Icons and columns in the table of tables (continued)

| Item | Description |
|------------------|--|
| Organized | <p>Column that shows the percentage of the table data that is organized based on the specified organizing keys for that table. For organized tables, this value is typically 100%, and 0% for tables that are not organized at all. Values in between indicate that an organizing key has been specified, and that the organization process is ongoing.</p> <p>For small tables, the value is not displayed (it only makes sense to use organizing keys when the table has at least 5 extents per data slice).</p> <p>If you archive tables with the High-Performance Storage Saver, the value decreases and ends up at 0% when you have archived the entire table. The reason is that the former accelerator-shadow table is emptied during the process. Hence the degree of organization can no longer be displayed for the archived partitions. The degree of organization of an accelerator-archive table (a table in the read-only table space) is not displayed, but remains the same as before archiving.</p> |

Query Monitoring

The **Query Monitoring** section shows an extensive number of additional buttons, information columns, and other controls. For a description, see [“Selecting and ordering query monitoring columns”](#) on page 138.

Stored procedure call

To display or refresh the list of schemas and tables, IBM Db2 Analytics Accelerator Studio invokes the **SYSPROC.ACCEL_GET_TABLES_INFO** stored procedure on your data server. For information about the privileges that are required to run this procedure and further details, see the appropriate section in the *IBM Db2 Analytics Accelerator for z/OS: Stored Procedures Reference*. A link to this document is provided under **Related reference** at the end of this section.

Related concepts

[Tables states](#)

A table can go through various states while it is being processed by IBM Db2 Analytics Accelerator for z/OS. The meaning of these states is explained here. In addition, it is shown which operation you can run on a table in a particular state. Finally, a diagram shows the possible shifts from one state to another (state transitions).

[How to select tables for query acceleration](#)

Selecting the proper tables for a query to be accelerated is basically simple: You need to define the tables that are referenced by the query. Slightly more thought needs to be spent on the choice of proper distribution keys and organizing keys.

Related tasks

[Defining tables on an accelerator](#)

Using the **Add Tables to Accelerator** or the **Select Tables to Add** wizard, you can define accelerator-shadow tables on an accelerator.

[Loading tables](#)

Successful queries against accelerator-shadow tables are possible only if the tables contain data. Therefore, you must load the tables after their definition (empty structure) has been copied to the accelerator.

[Enabling tables for query acceleration](#)

You can permit or prevent the sending of queries to an accelerator by enabling or disabling the corresponding accelerator-shadow tables.

[Specifying or changing a distribution key or organizing keys](#)

Distribution and organizing keys have a considerable impact on the query response time.

Including or excluding tables from incremental updates

Incremental updates can be enabled or disabled on the table level. This allows you to select the tables that take part in the process. When a subsystem has been configured for incremental updates, the toolbar of the accelerator view for regular accelerators shows an extra button, which works like a drop-down menu.

Selecting and ordering query monitoring columns

You can customize the view that displays the query history of an accelerator. That is, you can select the columns to be displayed. In IBM Db2 Analytics Accelerator Studio, you can also change the order of their appearance.

Related information

[IBM DB2 Analytics Accelerator for z/OS: Stored Procedures Reference](#)

Accelerator view for virtual accelerators

Here is a brief description of the status information and the function buttons on the **Accelerator** view for virtual accelerators.

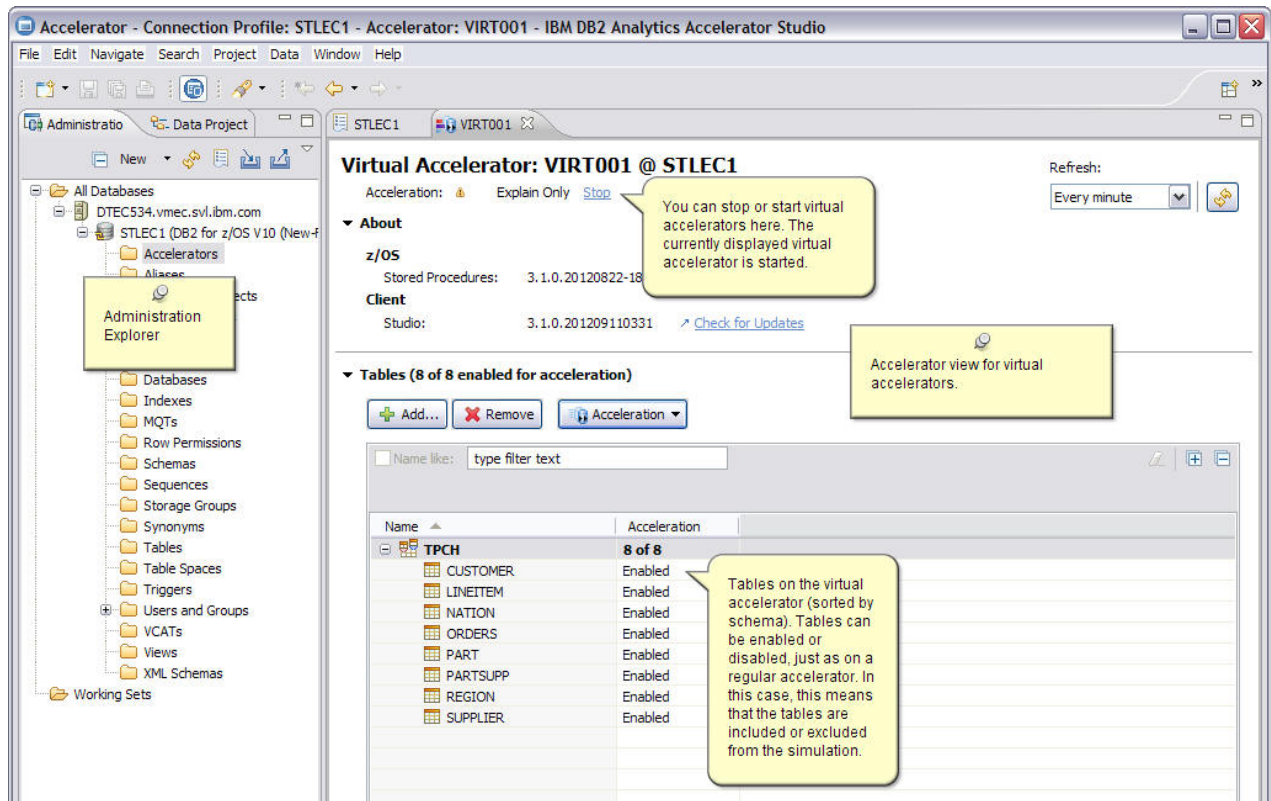

Figure 8. Accelerator view for virtual accelerators

Status information and functional links

The header of the **Accelerator** view for virtual accelerators contains status information and a functional link.

Acceleration

The status can be **Stopped** or **Explain Only**. These states indicate whether the virtual accelerator is currently enabled in Db2 for z/OS. The **Explain Only** state, as opposed to **Started**, is a reminder that this is a virtual accelerator rather than a regular accelerator. To change the current status, click **Start** or **Stop**.



About

| Table 23. Information in the About section | | | |
|---|--|--------------------------|--|
| Label | Description | Information blocks | Description |
| z/OS | Information about components on the z/OS data server | Stored procedures | The currently installed version of the IBM Db2 Analytics Accelerator stored procedures |
| Client | Information about your IBM Db2 Analytics Accelerator Studio installation | Studio | The currently installed version of IBM Db2 Analytics Accelerator Studio. Click Check for Updates to look for a newer version. |

Tables

The **Tables** section in the **Accelerator** view for virtual accelerators contains buttons and a table listing the accelerator-shadow tables on the virtual accelerator.

| Table 24. Buttons in the Tables section | |
|--|---|
| Button | Description |
| Add | Starts the Add Tables wizard. |
| Remove | Removes the selected accelerator-shadow tables from the virtual accelerator. |
| Acceleration | Opens a pull-down menu, on which you can enable or disable the selected accelerator-shadow tables so that these are included or excluded from the simulation. |

| Table 25. Icons and columns in the table of accelerator-shadow tables | |
|---|---|
| Item | Description |
|  | Icon representing the schema of an accelerator-shadow table |
|  | Icon representing an accelerator-shadow table |
| Name | Column containing the names of accelerator-shadow tables |
| Acceleration | Column that shows whether acceleration is enabled for an accelerator-shadow table |

Stored procedure call

To display or refresh the list of schemas and accelerator-shadow tables, IBM Db2 Analytics Accelerator Studio invokes the **SYSPROC.ACCEL_GET_TABLES_INFO** stored procedure on your data server. For information about the privileges that are required to run this procedure and further details, see the appropriate section in the *IBM Db2 Analytics Accelerator for z/OS: Stored Procedures Reference*. A link to this document is provided under **Related reference** at the end of this section.

Related concepts

[How to select tables for query acceleration](#)

Selecting the proper tables for a query to be accelerated is basically simple: You need to define the tables that are referenced by the query. Slightly more thought needs to be spent on the choice of proper distribution keys and organizing keys.

Related tasks

[Defining tables on an accelerator](#)

Using the **Add Tables to Accelerator** or the **Select Tables to Add** wizard, you can define accelerator-shadow tables on an accelerator.

[Enabling tables for query acceleration](#)

You can permit or prevent the sending of queries to an accelerator by enabling or disabling the corresponding accelerator-shadow tables.

Related information

[IBM DB2 Analytics Accelerator for z/OS: Stored Procedures Reference](#)

Interface elements of IBM Data Server Manager

Here is a brief description of the interface elements in IBM Data Server Manager that allow you to administer accelerators.

Note: When you start IBM Data Server Manager for the first time, you see the **Welcome** page (see [Figure 9](#) on page 77). You can start crucial functions directly from the **Welcome** page. However, if you'd rather like to see the main entry point for administering accelerators, click  in the upper left of the browser window and select **ADMINISTER > Accelerators**

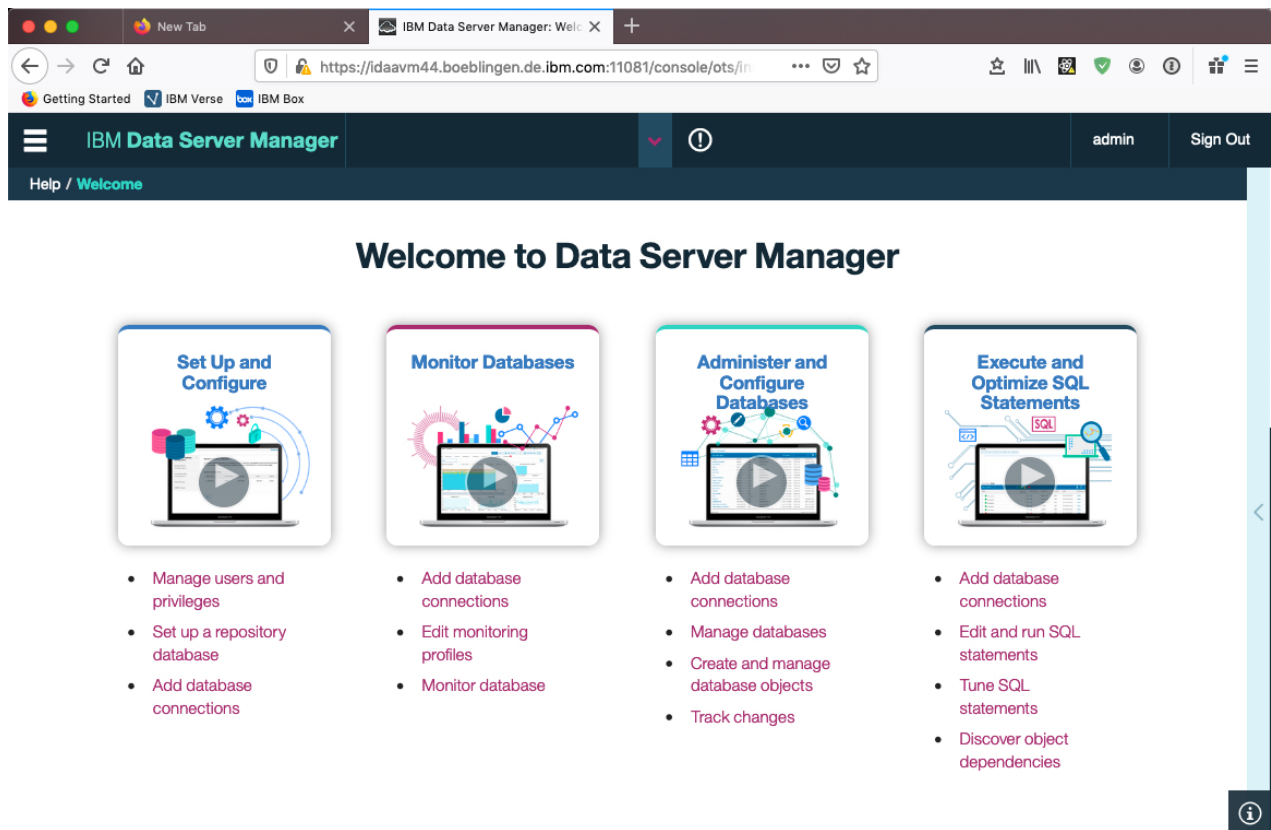



Figure 9. Welcome page of IBM Data Server Manager

Main menu

In IBM Data Server Manager, you access the main menu by clicking  in the upper left of the browser window.

From the top-level entry point, the following menu choices are relevant to the administration of accelerators:

ADMINISTER > Accelerators

To add, maintain, or remove accelerators.

RUN SQL

To run queries or create, save, and maintain reusable query scripts. From the **Run SQL** window, you also have access to a list of past queries and to a window that displays query results. You can run accelerated queries from this window.

SETTINGS > Manage Connections

To configure or select profiles for connections to Db2 subsystems or data sharing groups.

HELP > Open Help / Close Help

To show or hide context-sensitive help information in a side window on the right.

HELP > Welcome

To display the **Welcome** page, which provides an easy access point to essential functions.

Accelerator view

See a brief description of the status information and the function buttons on the **Accelerator** view of IBM Data Server Manager.

The screenshot shows the IBM Data Server Manager interface. At the top, there's a navigation bar with the title 'IBM Data Server Manager' and a user profile 'admin'. Below this is a breadcrumb trail 'Admin / Accelerators'. A toolbar contains buttons for 'Stop', 'Add', 'Remove', 'Manage', 'Monitor', and 'Refresh'. A table lists accelerators with columns for name, status, and space usage. The 'SIM148' row is selected. Below the table, the 'Acceleration Status' is 'Online' and the 'Diagnostics' section shows 'Used Space' as 'Not Available' and 'Credentials Valid Since' as '1/15/20 4:23 PM'. Callouts identify the 'Main menu', 'Connection to Db2 subsystem', 'Accelerators' table, 'Toolbar', and 'Details of selected accelerator'.

| ACCELERATOR NAME | ACCELERAT... | ACCELERATION STA... | USED SPACE | ACTIVE QUERIES |
|------------------|--------------|---------------------|------------|----------------|
| MAQ100 | OPPED | On | Available | 0 (0 queued) |
| SIM075 | ARTED | On | Available | 0 (0 queued) |
| SIM083 | -1 wo... | STOPPED | Unknown | Not Available |
| SIM127 | -1 wo... | STOPPED | Unknown | Not Available |
| SIM148 | 1 wor... | STARTED | Online | Not Available |
| SIM197 | 1 wor... | STARTED | Online | Not Available |
| SIM86 | -1 wo... | STOPPED | Unknown | Not Available |
| SIMP148 | -1 wo... | STARTED | Unknown | 0 (0 queued) |

Figure 10. **Accelerator** view in IBM Data Server Manager

Acceleration Status and Diagnostics

The **Acceleration Status** is displayed on top of the **Accelerator** view, followed by the **Diagnostics** section, which contains status information and controls for related functions.

Table 26. **Acceleration Status** and information in the **Diagnostics** section

| Label | Description |
|--------------------------------|---|
| Acceleration Status | <p>Whether the accelerator is currently enabled in Db2 for z/OS. To change the current status, click Start or Stop.</p> <p>If the accelerator is attached to a Db2 data sharing group, the behavior is different. The status <i>Started</i> is displayed if acceleration has been started for at least one member of the data sharing group. Other statuses are shown only if the status is the same for all members of the data sharing group. If the status of individual members is different, a warning icon is displayed.</p> <p>If you move the mouse pointer over the displayed status or the warning icon, a pop-up window shows the acceleration status for all members of the data sharing group.</p> <p>An additional functional link labeled Change is displayed for data sharing groups. Clicking it opens a window in which you can change the acceleration status of each member in the data sharing group.</p> |
| Used Space | <p>The amount of disk space that is taken up by the tables, in proportion to the available space on the accelerator.</p> <p>This is the space allocated in the file system of the accelerator for the table spaces of the connected Db2 subsystem. Currently, these table spaces can only grow. So if you have removed tables from the accelerator that have used space before, then this size is a high watermark that may include free space in the table spaces for this subsystem. This free space can be reused when you add additional tables from this Db2 subsystem to the accelerator or when existing tables grow. However, the free space cannot be used by other Db2 subsystems paired with the same accelerator because these Db2 subsystems have their own table spaces. The free space can be given back to the operating system when you remove the pairing between the current Db2 subsystem and the accelerator. This action will remove the table spaces for this subsystem.</p> |
| Credentials Valid Since | <p>Shows the date on which the last authentication of the accelerator took place. To renew the authentication, click Update.</p> |
| Trace | <p>Shows the trace profiles for the accelerator and the stored procedures that are currently in use. To change a profile, click Configure. To change the settings for the saving of trace information to a file, click Save. To delete the trace information that has been collected, click Clear.</p> <p>Note: The Clear option is not available for cloud accelerators.</p> |
| Encryption Details | <p>If you click Encryption Details, the Encryption Details window opens, which shows information about the use of encryption for the selected accelerator. This includes the status of hard-disk encryption, the status of encryption of data in motion, a list of encrypted IPsec tunnels (IP connections), and a list of the certificates that are used.</p> |

If an accelerator is selected, and you scroll down in the **Accelerator** view, you can see numerous details of the accelerator.

Administer / Accelerators

Used Space : Not Available

Credentials Valid Since : 12/16/19 12:35 PM [Update](#) [Encryption Details](#)

Trace : DEFAULT/OFF [Configure](#) [Save](#) [Clear](#)

Query execution statistics

Query History : 0 (0 queued)
: 1 successful -1 failed

Monitoring

Queue : Max. length: Avg. wait time: **N/A** Max. wait time: **N/A**

CPU cost : Query Execution: **N/A** Data maintenance: **N/A** Backup: **N/A**

Replication

Replication Status : Not Enabled

Replication Latency : N/A

z/OS

Stored Procedure Version : 7.5.1.20200122-1102

Server

[Transfer Updates](#) [Remove](#) [Apply other software version](#)

Accelerator Server Version : 5.1.7.201912121800

Netezza Firmware : 4.3.1.5

Access Server : 11.4.10600 (20191212-1800)

Unicode Sort Order : UTF8

Serial Number : 1234

Netezza Platform Software : 7.2.1.4-P3 [Build 105]

Netezza Host Platform : 5.4.0.1

Replication Engine : 11.4.0.2 [Build Release_5128] (20191212-1800)

Netezza Log Collector : 2.1.0.5

Operating System : Red Hat Enterprise Linux Server release 6.5 (Santiago)

Optional Server Packages

Buttons to start other functions

Version information

Queries

Table 27. Information in the **Queries** section

| Label | Description |
|-----------------------|--|
| Active Queries | The number of accelerated queries that are currently being processed. In parentheses, you see the number of queued queries. |
| Query History | Metrics related to completed queries since the start of the currently viewed accelerator, divided into the following categories: Successful Number of queries that ran successfully Failed Number of queries that failed |

Monitoring

The **Monitoring** section provides the following information:

Table 28. Information in the **Monitoring** section

| Label | Description |
|-----------------|---|
| Queue | <p>Metrics related to queuing since the start of the currently viewed accelerator:</p> <p>Max. length The highest number of queries in the queue, up to this time.</p> <p>Important: The Max. length and Max. wait time values cover all system transactions during a given period of time. This includes internal system queries, as well as INSERT, UPDATE, and DELETE operations. Therefore, these fields might display positive values even if there have been no active user queries recently. A discrepancy becomes noticeable when you compare the values with the ones reported in the query history, which provides the same information for individual queries.</p> <p>Avg. wait time Average time that queries had to stay in the queue. The basis for the calculation is all queries that were processed during the last minute.</p> <p>Max. wait time Longest time that a query stayed in the queue, that is, before it was processed.</p> |
| CPU Cost | <p>CPU time that was used since the start of the currently viewed accelerator, with regard to the connected Db2 subsystem. The total CPU time is divided into the following categories:</p> <p>Query execution CPU time needed for query processing</p> <p>Data maintenance CPU time needed for load and High Performance Storage Saver operations</p> <p>Replication CPU time needed for incremental updates</p> |

Replication

The **Replication** section contains information about incremental update processing:

Table 29. Information in the **Replication** section

| Label | Description |
|---------------------------|---|
| Replication Status | <p>Information is displayed only if incremental updates are configured. A status of Started indicates that the incremental update process is running for tables included in the process. Stopped indicates that the incremental update process has been suspended. To change the current status, click Start or Stop.</p> |

Table 29. Information in the Replication section (continued)

| Label | Description |
|--|--|
| Replication Latency | <p>Only visible if incremental updates are configured. This is not the case in Figure 10 on page 79. The value indicates how much the incremental update function is lagging behind. Possible values:</p> <p>Stopped Incremental updates have been stopped for the entire accelerator.</p> <p>Low It will take less than three minutes to propagate recent changes to the corresponding accelerator-shadow tables.</p> <p>Medium Recent changes to the original Db2 tables will be propagated to the corresponding accelerator-shadow tables within three and six minutes.</p> <p>High It will take six minutes or longer to apply recent changes to Db2 tables to the corresponding accelerator-shadow tables.</p> <p>See Note on replication latency.</p> <p>Clicking Show Events opens the event viewer, which keeps a record of all transactions that are related to incremental updates.</p> |
| Replication Latency (continued) | <p>Source Agent Number of data changes to relevant Db2 for z/OS tables (tables for which accelerator-shadow tables have been defined and that are included in the incremental update process.</p> <p>Inserts Number of row inserts in the relevant Db2 for z/OS tables.</p> <p>Updates Number of updates to rows in the relevant Db2 for z/OS tables.</p> <p>Deletes Number of row deletions from the relevant Db2 for z/OS tables.</p> <p>Latency Repetition of the Replication Latency value.</p> <p>Clicking Show Events opens the event viewer, which keeps a record of all transactions that are related to incremental updates.</p> |

Note on replication latency: The *replication latency* is disclosed through different channels, at different points in time. Sometimes, it is calculated by different systems. Values are reported:

- In the **Accelerator** view as described in the previous table
- When you run the Db2 command -DIS ACCEL(<name>) DETAIL
- In trace files:

```
<Event id="61098" timestamp="2018-11-28 18:07:51" level="W" addressee="0" >
  The current replication latency of XXXXXs on DB2 location ADB2K04 (subscription
  DWE9PLVY)
  has exceeded the threshold of 3600s.
</Event>
```

- In the status monitoring counter Q8STCRL
- As a result of running the SYSPROC.ACCEL_CONTROL_ACCELERATOR stored procedure in connection with the <getAcceleratorInfo> parameter.

These systems or reporting channels are not synced, so deviating values are inevitable. Deviations can be considerable, depending on the channel that is tapped and on the time when this is done. Stick to one reporting channel if you need to compare latency values.

z/OS

The following information is displayed in the **z/OS** section:

| <i>Table 30. Information in the z/OS section</i> | |
|--|--|
| Label | Description |
| Stored Procedure Version | The currently installed version of the IBM Db2 Analytics Accelerator stored procedures |

Server

The **Server** section contains information about software components that are installed on the IBM PureData System for Analytics.

| <i>Table 31. Information in the Server section</i> | |
|--|--|
| Label | Description |
| Accelerator Server Version | <p>The version of the IBM Db2 Analytics Accelerator for z/OS software that is currently in use. To transfer an update package from the z/OS UNIX file system (zFS) on z/OS to the accelerator, click Transfer Updates. To remove an obsolete version no longer used, click Remove. To use a different version of the IBM Db2 Analytics Accelerator for z/OS software, click Apply other software version.</p> <p>Note: The Transfer updates, Remove, and Apply other software version options are not available for cloud accelerators.</p> |
| Netezza Firmware (FDT) | <p>Only visible if version 4 or later of the IBM Db2 Analytics Accelerator for z/OS software is installed on the accelerator. This is the current version of the Netezza Firmware and Diagnostics and Tools (FDT) running on the accelerator (IBM PureData System for Analytics). To transfer an FDT update package from the z/OS UNIX file system (zFS) to the IBM PureData System for Analytics, click Transfer files. The installation of the Netezza Firmware (FDT), however, must be carried out by a service engineer and requires a downtime of the IBM PureData System for Analytics.</p> |
| Access Server | <p>Only visible if incremental updates are configured. This is the version of the CDC Access Server, the central component in the incremental update process which manages the list of subscriptions (incremental update requests) and controls the agents involved in the process.</p> |
| Unicode Sort Order | <p>Information is displayed only if the connected Db2 subsystem or data sharing group is a Db2 11 for z/OS database. The value reflects the sort order that was selected for tables on the accelerator. Possible values are UTF8 and UTF16. The choice has an impact on how supplementary Unicode characters are sorted in query results.</p> |
| Netezza Platform Software (NPS) | <p>The current version of the Netezza Platform Software (NPS).</p> <p>Before you install a new version of the Netezza Platform Software (NPS), make sure that the required minimum versions of the Netezza Firmware (FDT) and the Netezza Host Platform (HPF) are installed.</p> <p>To transfer an update package from the z/OS UNIX file system (zFS) to the IBM PureData System for Analytics, click Transfer files.</p> |

Table 31. Information in the **Server** section (continued)

| Label | Description |
|------------------------------------|--|
| Netezza Host Platform (HPF) | <p>Only visible if version 4 or later of the IBM Db2 Analytics Accelerator for z/OS software is installed on the accelerator. This is the current version of the Netezza Host Platform (HPF) running on the accelerator (IBM PureData System for Analytics). The HPF software contains kernel updates, firmware, and other special software used by the Netezza host servers.</p> <p>To transfer an FDT update package from the z/OS UNIX file system (zFS) to the IBM PureData System for Analytics, click Transfer files. The installation of the Netezza Host Platform (HPF), however, must be carried out by a service engineer and requires a downtime of the IBM PureData System for Analytics.</p> |
| Replication Engine | Information is displayed only if incremental updates are configured. This is the version of the CDC Apply Agent, which propagates data changes to the IBM PureData System for Analytics, according to the instructions received from the CDC Access Server. |

Optional Server Packages

If external packages (remote stored procedures) are installed, the package name is shown in the **Optional Server Packages** section. This could be, for example, the *IBM Netezza Analytics* package. In addition, buttons are displayed to enable or disable the package for the selected accelerator.

List of tables

Here is a brief description of the elements and interactive controls in the view that lists the tables on an accelerator

List of tables

To display the list of tables on an accelerator, select the accelerator (row) in the **Accelerator** view and click the **Manage** button. The list of tables has a toolbar of its own, with buttons described in [Table 32 on page 86](#). See the following figure:

The screenshot shows the IBM Data Server Manager interface. At the top, there is a navigation bar with the text "IBM Data Server Manager" and "ABCXYZ4". Below this, there is a breadcrumb trail "Administer / Accelerators" and a link "Back to Accelerator View". The main content area is titled "Accelerator: ABC100" and "List of tables". Below the title, there are tabs for "Tables" and "Queries". A toolbar contains buttons for "Add", "Remove", "Load", "Alter Keys", "List Tasks", "Acceleration", "Storage Saver", and "Federation". The table below has the following data:

| <input type="checkbox"/> | SCHEMA NAME | TABLE NAME | SIZE | ACCELERATION | ERRORS | LAST LOAD TIME | LAST LOAD |
|-------------------------------------|-------------|------------|---------|--------------|--------|-------------------|----------------------|
| <input type="checkbox"/> | TPCH | - | N/A | - | None | - | - |
| <input type="checkbox"/> | TPCH | NATION | 3 MB | Disabled | None | 12/16/19 12:57 PM | Loaded |
| <input checked="" type="checkbox"/> | TPCH | PARTSUPP | 1.93 GB | Disabled | None | 12/16/19 12:57 PM | Loaded |
| <input type="checkbox"/> | TPCH | PART | 377 MB | Disabled | None | 12/16/19 12:57 PM | Loaded |
| <input type="checkbox"/> | TPCH | ORDERS | 2.37 GB | Disabled | None | 12/16/19 12:57 PM | Loaded |
| <input type="checkbox"/> | TPCH | CUSTOMER | 401 MB | Disabled | None | 12/16/19 12:57 PM | Loaded |
| <input type="checkbox"/> | TPCH | SUPPLIER | 30 MB | Disabled | None | 12/16/19 12:39 PM | Loaded |
| <input type="checkbox"/> | TPCH | I INFITFM | 0 MB | Disabled | None | | Initial Load Pending |

Figure 11. The list of tables in IBM Data Server Manager

Table 32. Buttons on the toolbar of the list of tables

| Button | Description |
|----------------------|---|
| Add | Starts the Add Tables wizard. |
| Remove | Removes the selected tables from the accelerator. |
| Load | Opens the Load Tables window, in which you can select accelerator-shadow tables for loading and set the lock scope for the load process. |
| Alter Keys | Opens a window in which you can select or change the distribution and organizing keys that are used by the accelerator. |
| List Tasks | Opens the List Tasks window, which displays the running tasks on the currently viewed accelerator, such as table load processes. To cancel a running task, select it in the list and click Cancel Selected Task . |
| Acceleration | Opens a pull-down menu, from which you can enable or disable the selected accelerator-shadow tables so that these are included or excluded from query acceleration. |
| Storage Saver | Allows you to archive partitions on an accelerator or restore these to their original locations. The button opens a menu with the following choices: Move Partitions to Accelerator Opens the Move Storage Saver Partitions to Accelerator window, which allows you to select Db2 for z/OS tables or partitions to archive the data therein on the accelerator currently viewed. Restore Partitions to Db2 Opens Restore Storage Saver Partitions to Db2 window, in which you can select accelerator-archive tables and partitions that have been archived on the currently selected accelerator in order to restore these. |
| Federation | Allows you to control federated access. The button opens a menu with the following choices: Grant Grants a referencing Db2 subsystem access to tables that belong to another Db2 subsystem (called owning or remote Db2 subsystem) Create Reference Creates reference tables on the accelerator shared between the referencing Db2 subsystem and the owning Db2 subsystem. The reference tables contain metadata for access to the original data by the referencing Db2 subsystem. Revoke Revokes previously granted table access. Remove Removes reference tables. |
| Replication | Only visible if incremental updates are configured. This is not the case in Figure 11 on page 85 . Clicking the button opens a pull-down menu from which you can enable or disable incremental updates for selected accelerator-shadow tables. |

The list of tables contains the following columns:

Table 33. Columns in the list of tables

| Column | Description |
|---------------------------------|--|
| SCHEMA NAME | Column containing schema names |
| TABLE NAME | Column containing the table names |
| SIZE | Column containing the table sizes. If rows have been deleted from the table (for example by replication or by a partial reload), a certain space on the pages might remain empty. So if you run many data maintenance jobs on a table, such as replication, without ever reloading the table fully, the table might still grow over time, even if the overall number of rows does not change. |
| ACCELERATION | Column that shows whether acceleration is enabled for a table |
| ERRORS | Column that shows the number of errors in each table |
| LAST LOAD TIME | Column that shows the timestamp of the last successful load for each table or the current table state. Because accelerator-only tables are not loaded by IBM Db2 Analytics Accelerator functions, the column always shows the table state (for example <i>AOT ready</i>) for this type of table. |
| LAST LOAD | Column that shows the table states, such as, <i>loaded</i> , <i>load pending</i> , and so on. |
| STORAGE SAVER PARTITIONS | Column that provides information about the archived partitions of a table. The column is visible only if tables with archived partitions exist. At the schema level, the column shows how many partitions out of the total number of partitions were archived. At the table level, it shows the compressed data size of the archived partitions and the number of rows in these partitions. If archiving is in progress for a partition, the columns shows <i>In Progress</i> . |
| REPLICATION SINCE | Only visible if incremental updates are configured. Column that shows the last incremental-update capture-point (a timestamp) for incrementally updated accelerator-shadow tables or <i>Disabled</i> for the tables that are not updated in that way. If continuous incremental updates are enabled, the column shows <i>Suspended</i> when a table load has started and incremental updates are therefore on halt, and <i>Refreshing</i> when table changes are being applied, be this through the ongoing load process or the draining of incremental updates from the spill queue. |
| DISTRIBUTION KEY | Column that shows <i>Random</i> if random distribution is used or the names of distribution-key-columns if a distribution key is used. |
| SKEW | Column that shows the skew value for each table on the accelerator. The skew value is a metric for the distribution imbalance of table rows across the snippet-processing units (SPUs) or worker nodes. The value is the difference between the smallest and the largest data slice for a table in megabytes (MB). |
| ORGANIZING KEYS | Column that shows the names of the organizing keys (column names) that were selected for a table. |

Table 33. Columns in the list of tables (continued)

| Column | Description |
|------------------|--|
| ORGANIZED | <p>Column that shows the percentage of the table data that is organized based on the specified organizing keys for that table. For organized tables, this value is typically 100%, and 0% for tables that are not organized at all. Values in between indicate that an organizing key has been specified, and that the organization process is ongoing.</p> <p>For small tables, the value is not displayed (it only makes sense to use organizing keys when the table has at least 5 extents per data slice).</p> <p>If you archive tables with the High Performance Storage Saver, the value decreases and ends up at 0% when you have archived the entire table. The reason is that the former accelerator-shadow table is emptied during the process. Hence the degree of organization can no longer be displayed for the archived partitions. The degree of organization of an accelerator-archive table (a table in the read-only table space) is not displayed, but remains the same as before archiving.</p> |
| REMOTE | Column that indicates whether federated access has been granted to tables. |

Stored procedure call

To display or refresh the list of tables, IBM Data Server Manager invokes the SYSPROC.ACCEL_GET_TABLES_INFO stored procedure on your data server. For information about the privileges that are required to run this procedure and further details, see the appropriate section in the *IBM Db2 Analytics Accelerator for z/OS: Stored Procedures Reference*. A link to this document is provided under **Related reference** at the end of this section.

List of queries

Here is a brief description of the elements and interactive controls in the view that lists the queries on an accelerator.

To display the list of active or past queries on an accelerator:

1. Select the accelerator (row) in the **Accelerator** view.
2. Click the **Manage** button.
3. Click the **Queries** tab.

The toolbar on top of the list of queries has few buttons, which are described in [Table 34 on page 89](#). See the following figure:

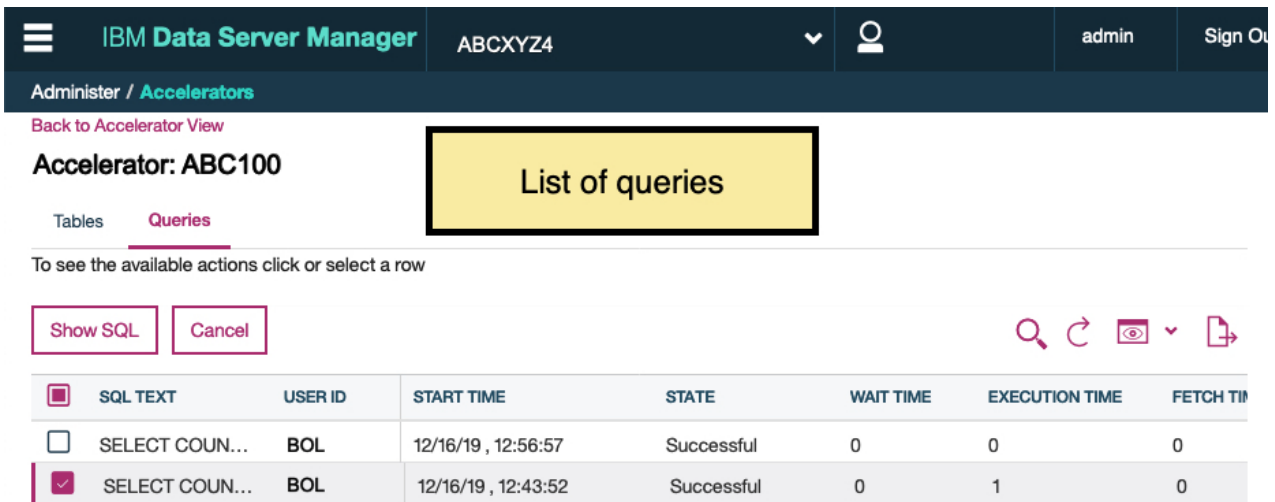

Figure 12. The list of queries in IBM Data Server Manager

| Table 34. Buttons on the toolbar of the list of queries | |
|---|---|
| Button | Description |
| Show SQL | Shows the SQL code of a query after selecting it in the list. |
| Cancel | Cancel a running query after selecting it in the list. |

Columns

The list of queries contains the following columns:

| Table 35. Columns in the list of queries | |
|--|--|
| Column | Description |
| SQL TEXT | Column that shows the beginning of a query's SQL code. |
| USER ID | Column that shows the IDs of the users who submitted the queries. |
| START TIME | Times when queries were received by IBM Db2 Analytics Accelerator for z/OS. For more information on the time values, see the following description . |
| STATE | Processing states that queries are in. The following states are possible: <ul style="list-style-type: none"> UNKNOWN The state cannot be determined. QUEUED A query has been passed to the Netezza system for processing. RUNNING The query is being processed by the Netezza system. FETCHING The Netezza system has finished processing the query, but Db2 for z/OS has not yet finished collecting the results. FAILED The query did not run to completion because one or more errors occurred. SUCCESSFUL Query execution has been completed successfully. CANCELED The query did not run to completion because it was canceled by a user. |

Table 35. Columns in the list of queries (continued)

| Column | Description |
|-----------------------|---|
| WAIT TIME | Periods of time that queries had to “spend” in the queue before they were processed by the IBM PureData System for Analytics. For more information on the time values, see the following description . |
| EXECUTION TIME | The time a query spent in the queue before it was sent to the accelerator plus the time needed to process the query on the IBM PureData System for Analytics. For more information on the time values, see the following description . |
| FETCH TIME | The time interval starting with the first retrieval of a result row by Db2 and ending with the last. In most cases, Netezza query execution has already finished when the result retrieval process is still ongoing. For more information on the time values, see the following description . |
| ELAPSED TIME | The total time that was needed to process a query (from the state QUEUED to the state FAILED, SUCCESSFUL, or CANCELED). For more information on the time values, see the following description . |
| RESULT SIZE | The data size of the rows that were returned in query results (in MB or GB) from the accelerator to Db2 for z/OS. |
| ROWS RETURNED | The number of rows that were returned by the accelerator as query results. |

Chapter 5. Administration tasks

See an overview of the tasks that you can complete from your administration client.

Prerequisites

Before you go about a task, check whether you meet the requirements for running your administration client:

- Network connections must exist between the database server and the machine on which the administration client is installed. In addition, network connections must exist between the database server and the accelerators.
- At least one accelerator (hardware) must be installed and connected to your database server.
- The appropriate Program Temporary Fixes (PTFs) must be installed so that IBM Db2 Analytics Accelerator for z/OS can connect to your database management system.
- IBM Db2 Analytics Accelerator for z/OS stored procedures must exist on the database server.
- IBM Db2 Analytics Accelerator for z/OS jobs have been run to configure and integrate the accelerator hardware and software into your database environment.

Creating a database connection profile

Create a database connection profile to gain access to a Db2 subsystem on a database server. A Db2 subsystem houses one or more databases, in which the source data for query acceleration (schemas and tables) is kept.

About this task

No matter which administration client you use, the connection information is stored in profiles for reuse. Having created a profile, you can reconnect to a database by double-clicking the icon representing the profile in the **Administration Explorer** or by selecting the profile from the drop-down list of the top banner in IBM Data Server Manager.

Procedure

1. Open the wizard or window to add a database connection:

| | |
|--------------------------------------|---|
| IBM Db2 Analytics Accelerator Studio | On the header of the Administration Explorer on the left, click the downward-pointing arrow next to New and select New Connection to a Database . |
| IBM Data Server Manager | a. Click  in the upper left. b. Select SETTINGS > Manage Connections . c. Select Add > Add a database . |

2. Give the database connection profile a name:

| | |
|--------------------------------------|--|
| IBM Db2 Analytics Accelerator Studio | Decide how to name the database connection profile: <ul style="list-style-type: none">• To use the name of the database server that you want to connect to, leave Use default naming convention selected. |
|--------------------------------------|--|

| | |
|-------------------------|--|
| | <ul style="list-style-type: none"> To choose a different name, clear Use default naming convention, and type the name in the Connection Name field. |
| IBM Data Server Manager | Type the name in the Database connection name field. |

3. Select the database management system:

| | |
|--------------------------------------|--|
| IBM Db2 Analytics Accelerator Studio | <p>From the Select a database manager list, select Db2 for z/OS.</p> <p>Make sure that in the JDBC driver drop-down list, IBM Data Server Driver for JDBC and SQLJ (JDBC 4.0) Default is selected.</p> |
| IBM Data Server Manager | From the Data server type drop-down list, select Db2 for z/OS . |

4. Specify the **Location** name of the Db2 subsystem. This is the name of the Db2 subsystem in the Db2 system table SYSIBM.LOCATIONS.

| | |
|--------------------------------------|---|
| IBM Db2 Analytics Accelerator Studio | Type the name in the Location field. |
| IBM Data Server Manager | Type the name in the Location field. |

Tip: To determine the **Location**, **Host** name, and **Port number**, a Db2 for z/OS systems programmer or database administrator can issue a `-DIS DDF` command.

5. Specify the host name or IP address of the computer on which the database server is located:

| | |
|--------------------------------------|---|
| IBM Db2 Analytics Accelerator Studio | Type the host name or IP address in the Host field. |
| IBM Data Server Manager | Type the host name or IP address in the Host name field. |

6. Specify the port number for connections to the database server:

| | |
|--------------------------------------|---|
| IBM Db2 Analytics Accelerator Studio | In the Port number field, you see that port number 446 is selected by default. Leave this setting unless the database server uses another port. |
| IBM Data Server Manager | In the Port number field, type the number of the port that was configured during the installation of IBM Data Server Manager. By default, this is 11511 for secure (https://) connections. |

7. Select specific options of your administration client:

| | |
|--------------------------------------|---|
| IBM Db2 Analytics Accelerator Studio | <p>Select Retrieve objects created by this user only if you want to restrict database access to the databases, schemas, tables, and other objects that were created by the logon user.</p> <p>If you do not select this option (default), IBM Db2 Analytics Accelerator Studio will show and make selectable all databases, schemas, and tables that the logon user has access to, including those to which this user might have only read access.</p> |
|--------------------------------------|---|

| | |
|-------------------------|---|
| IBM Data Server Manager | <p>Select:</p> <ol style="list-style-type: none"> Enable operation to allow a user (ID) to administer, tune, and query the connected Db2 subsystem. Enable data collection to allow a user (ID) to collect data from the connected Db2 subsystem. <p>Both options are required for successful operation of IBM Db2 Analytics Accelerator. You specify the corresponding user IDs on the next tab.</p> |
|-------------------------|---|

8. If you use IBM Data Server Manager, click the **Credential** tab.

9. Specify the user ID of the logon user or operation user:

| | |
|--------------------------------------|---|
| IBM Db2 Analytics Accelerator Studio | In the User name field, type the user ID that you want to use to log on to the database server. |
| IBM Data Server Manager | In the group box labeled Operation credentials , you find a User ID field. Type the ID of the logon user in this field. |

Note that you can only use your administration client successfully if the logon user has sufficient rights to run the stored procedures that are called by the administration client functions. The section *Appendix C. Required access rights* in the *IBM Db2 Analytics Accelerator for z/OS: Stored Procedures Reference* lists the privileges that are required to run a particular stored procedure. If you are uncertain, use an ID with SYSADMIN authority.

10. Specify the password belonging to the logon user ID or operation user ID:

| | |
|--------------------------------------|--|
| IBM Db2 Analytics Accelerator Studio | <ul style="list-style-type: none"> In the Password field, type the password of the logon user. Leave the Save password check box deselected. <p> Attention: You can select Save password to avoid having to enter the password each time that you want to work with the database server. This, however, is not recommended because only a lightweight encryption is applied when the password is stored on your local hard disk.</p> <ul style="list-style-type: none"> Leave the Default schema field blank. |
| IBM Data Server Manager | <ol style="list-style-type: none"> Under Operation credentials, in the Password field, type the password of the logon user. To save the logon password so that you do not need to provide it each time you connect to the same Db2 subsystem, select Save credentials to repository. |

11. Specify a secondary user ID (optional for IBM Db2 Analytics Accelerator Studio), or the data collection user ID for IBM Data Server Manager:

| | |
|--------------------------------------|--|
| IBM Db2 Analytics Accelerator Studio | <p>In many organizations, it is a common practice to have personal user IDs with restricted authority and special-purpose user IDs (groups in most cases) with extensive privileges in a certain field. IBM Db2 Analytics Accelerator Studio supports this practice in that you can specify a secondary user ID, which might have the privileges that your logon user ID lacks, such as the privilege to run stored procedures. If the secondary ID is a group user ID, the logon user must of course be a member of that group. To specify a secondary user ID, follow these steps:</p> <ol style="list-style-type: none"> On the Connection Parameters page, click the Optional tab. In the Property field, type the following statement: <div data-bbox="922 684 1469 737" style="background-color: #f0f0f0; padding: 2px; margin: 5px 0;">currentSQLID</div> In the Value field, type the secondary user ID. Click Add. Click the General tab to return to that page and complete the logon. |
| IBM Data Server Manager | <p>Under Data collecting credentials, in the User ID field, type the ID of the data collection user (this user is related to the Enable data collection option in step “Creating a database connection profile” on page 91).</p> |

12. Test the connection or connections:

| | |
|--------------------------------------|--|
| IBM Db2 Analytics Accelerator Studio | Click Test Connection to check if you can log on to the database server. |
| IBM Data Server Manager | <ol style="list-style-type: none"> In the Operation credentials group box, click the Test Connection button to check if your operation user can log on to the Db subsystem. In the Data collecting credentials group box, click the Test Connection button to check if your data collection user can log on to the Db subsystem. |

13. Save your database connection profile:

| | |
|--------------------------------------|-----------------------|
| IBM Db2 Analytics Accelerator Studio | Click Finish . |
| IBM Data Server Manager | Click OK . |

Results

After creating the profile, your administration client automatically connects to the Db2 subsystem.

What to do next

If it takes too long to load all objects of the Db2 subsystem into the current view of your administration client (more than one minute), you can set a filter to limit the number of schemas to be loaded:

| | |
|--------------------------------------|--|
| IBM Db2 Analytics Accelerator Studio | <ol style="list-style-type: none"> 1. In the Administration Explorer, right-click the icon representing the Db2 subsystem (database symbol). 2. Select Properties from the menu. 3. In the Properties for ... window, select Default Schema Filter. 4. Clear the Disable filter check box. This activates the filter controls. 5. From the Name drop-down list, select a suitable filter mask. In the adjacent text field, type the filter string. For example, to exclude all schemas whose names starts with the characters BLU: <ol style="list-style-type: none"> a. From the Name drop-down list, select Does not start with the characters. b. In the text field, type BLU. 6. Click Apply. |
| IBM Data Server Manager | <ol style="list-style-type: none"> 1. Select  > ADMINISTER > Schemas. <ul style="list-style-type: none"> • You can use the Filter by Name field to quickly filter the list of schemas using ordinary characters and wildcard characters (% for strings and _ for individual characters). For example, entering A% will display just the schemas whose names start with the letter A. • Another way is to use the filter editor: <ol style="list-style-type: none"> a. Click the funnel icon in the upper right. b. In the Filter window, you can define many types of filter rules. For example, to exclude all schemas whose names start with the characters BLU: <ol style="list-style-type: none"> i) Leave the first drop-down list unchanged. ii) From the second drop-down list, select does not contain. iii) In the text entry field, type BLU. iv) Click Apply. The Filter window closes, and the list of schemas is refreshed. Notice that the funnel icon is completely filled with color when a filter has been applied. |

Connecting to a database server

The steps to connect to a Db2 subsystem differ with respect to the administration client that you use.

Before you begin



If it takes too long to load all objects of the Db2 subsystem into the current view of your administration client (more than one minute), you can set a filter to limit the number of schemas to be loaded:

| | |
|--------------------------------------|--|
| IBM Db2 Analytics Accelerator Studio | <ol style="list-style-type: none"> 1. In the Administration Explorer, right-click the icon representing the Db2 subsystem (database symbol). 2. Select Properties from the menu. 3. In the Properties for ... window, select Default Schema Filter. 4. Clear the Disable filter check box. This activates the filter controls. 5. From the Name drop-down list, select a suitable filter mask. In the adjacent text field, type the filter string. For example, to exclude all schemas whose names starts with the characters BLU: <ol style="list-style-type: none"> a. From the Name drop-down list, select Does not start with the characters. b. In the text field, type BLU. 6. Click Apply. |
| IBM Data Server Manager | <ol style="list-style-type: none"> 1. Select  > ADMINISTER > Schemas. <ul style="list-style-type: none"> • You can use the Filter by Name field to quickly filter the list of schemas using ordinary characters and wildcard characters (% for strings and _ for individual characters). For example, entering A% will display just the schemas whose names start with the letter A. • Another way is to use the filter editor: <ol style="list-style-type: none"> a. Click the funnel icon in the upper right. b. In the Filter window, you can define many types of filter rules. For example, to exclude all schemas whose names start with the characters BLU: <ol style="list-style-type: none"> i) Leave the first drop-down list unchanged. ii) From the second drop-down list, select does not contain. iii) In the text entry field, type BLU. iv) Click Apply. The Filter window closes, and the list of schemas is refreshed. Notice that the funnel icon is completely filled with color when a filter has been applied. |

Procedure

Depending on your administration client, use one of the following approaches:

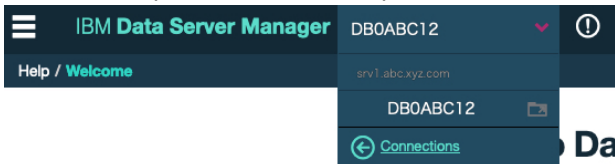
| | |
|--------------------------------------|--|
| IBM Db2 Analytics Accelerator Studio | In the Administration Explorer , double-click the icon representing the Db2 subsystem. For example:  STLEC1 |
|--------------------------------------|--|



| | |
|--------------------------------|---|
| <p>IBM Data Server Manager</p> | <p>IBM Data Server Manager tries to reconnect to the previously connected Db2 subsystem by default. If the reconnection fails, or you want to connect to a different subsystem, you can select the appropriate connection name from the drop-down list on the top banner. For example:</p>  <p>Alternatively:</p> <ol style="list-style-type: none"> Click  and select SETTINGS > Manage Connections. Select the box in front of a listed connection. |
|--------------------------------|---|

Results

You see the following results if the connection was successful:

| | |
|---|--|
| <p>IBM Db2 Analytics Accelerator Studio</p> | <p>The icon representing the subsystem changes and the database object types, such as table spaces or tables, are displayed in a folder hierarchy in the Administration Explorer.</p> |
| <p>IBM Data Server Manager</p> | <p>The views on the main menu, under the ADMINISTER submenu, are populated.</p> |

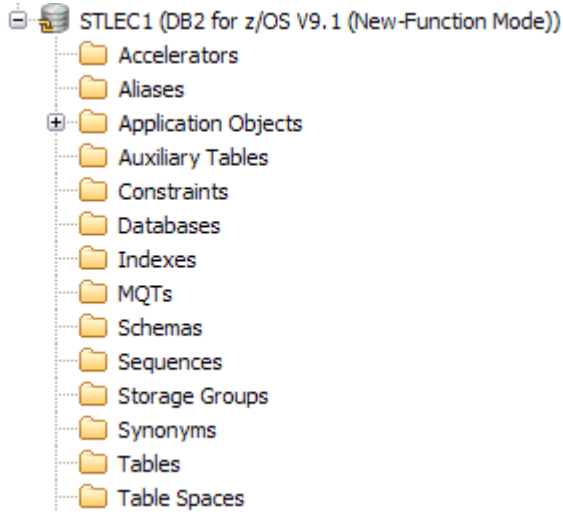
Examples

| | |
|---|--|
| <p>IBM Db2 Analytics Accelerator Studio</p> | <p>After a successful connection, you can see the following folder hierarchy in the Administration Explorer:</p>  |
| <p>IBM Data Server Manager</p> | <p>Tables in the connected Db2 subsystem are displayed after selecting  > ADMINISTER > Tables:</p> |

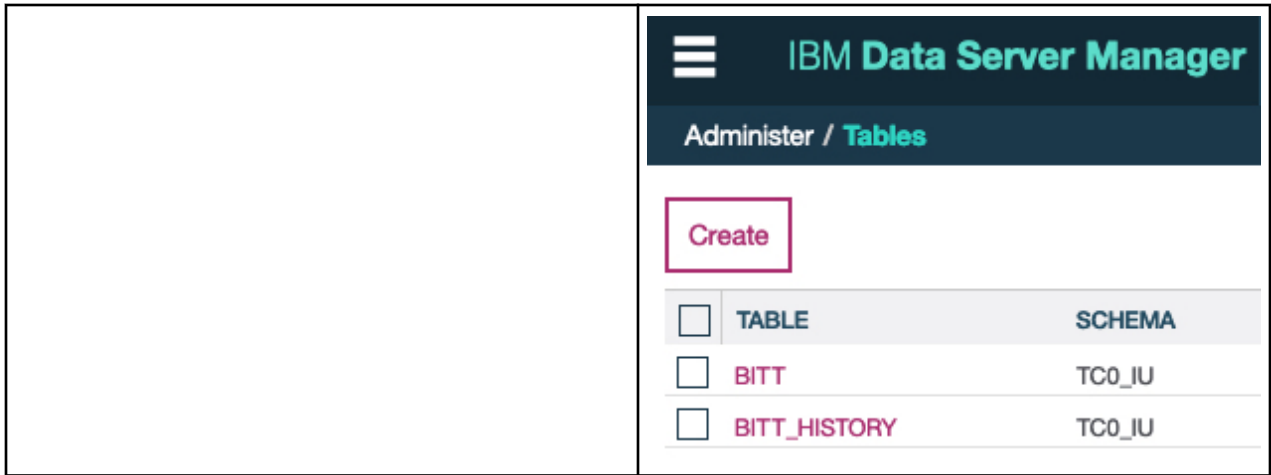

Exploring a database server

When a connection to a database server has been established successfully, you can navigate to various folders or pages of your administration client to obtain information about the objects in the database. You can, for example, find out which schemas and tables the connection gives you access to.

Procedure

Follow these steps:

| | |
|--------------------------------------|--|
| IBM Db2 Analytics Accelerator Studio | <ol style="list-style-type: none"> If necessary, open the Administration Explorer and expand the node representing the database server connection. Expand the single node underneath, which represents the database server. Navigate downwards in the folder hierarchy to see the objects on the database server. |
| IBM Data Server Manager | <ol style="list-style-type: none"> Click  in the upper left. Expand the ADMINISTER submenu. Select the appropriate choice for the type of objects you'd like to view, for example Tables, Views, Schemas, or Accelerators. |

Results

| | |
|--------------------------------------|---|
| IBM Db2 Analytics Accelerator Studio | <p>Selecting a folder shows the corresponding objects in the Object List Editor.</p> <p>When IBM Db2 Analytics Accelerator for z/OS has been set up correctly, the Administration Explorer shows a folder called Accelerators. You can open this folder to display the list of configured accelerators. Double-clicking an accelerator name opens a view that shows the details of this accelerator.</p> |
| IBM Data Server Manager | <p>Selecting a choice from the ADMINISTER submenu displays a page that lists the objects of</p> |

| | |
|--|--|
| | <p>your choice. Various control buttons allow you to interact with these objects.</p> <p>To display a list of the connected accelerators, select ADMINISTER > Accelerators from the main menu. To view the details of an accelerator, select its entry in the list. The details are displayed at the bottom of the page.</p> |
|--|--|

Adding accelerators

Adding an accelerator to your configuration is a two-step process. First, you must obtain a pairing code from the IBM Db2 Analytics Accelerator Console. Second, you must enter this pairing code along with the IP address and the name of the accelerator in the **Add Accelerator** wizard of your administration client.

Obtaining the pairing code for authentication

Communication between an accelerator and a Db2 subsystem requires both components to share credentials. These credentials are generated after you submit a temporarily valid pairing code. This step is required each time you add a new accelerator. The following steps describe how to obtain the pairing code.

About this task

Note: You can renew the authentication for an existing accelerator without having to use a new pairing code. To do so, click the **Update** link in the **Accelerator** view.

The steps *Obtaining the pairing code for accelerator authentication* and *Adding Accelerators* (next topic) belong together, but are seldom carried out by the same person. Since the pairing code obtained from the IBM Db2 Analytics Accelerator Console is only valid for a limited time (30 minutes by default), the persons operating the console and the administration client must coordinate their steps.

To obtain the pairing code, the **SYSPROC.ACCEL_UPDATE_CREDENTIALS** stored procedure is run on your data server. For information about the privileges that are required to run this procedure and further details, see the appropriate section in the *IBM Db2 Analytics Accelerator for z/OS: Stored Procedures Reference*. A link to this document is provided under **Related reference** at the end of this section.

Procedure

1. Ask the network administrator or the person who did the TCP/IP setup for the IP address (virtual IP or wall IP address) of the accelerator. Make a note of this information. You need to enter it as you complete the steps that follow.
2. Start a client or emulator session (using, for example, IBM Personal Communications or IBM Host On-Demand) to communicate with the z/OS system on which your Db2 subsystem is located.
3. Log on to TSO/ISPF.
4. Enter the following command:

```
tso telnet <hostname> 1600
```

where

<hostname>

Is the IP address of the accelerator that is connected to the Db2 for z/OS data server.

1600

Is the number of the port configured for accessing the IBM Db2 Analytics Accelerator Console using a telnet connection between the Db2 for z/OS data server and the accelerator.

For example:

```
tso telnet 203.0.113.8 1600
```

5. When prompted, enter the console password.

The initial password is dwa -1234. You must change this password at the first logon.

6. Press the Pause key, then Enter to display the following screen:

```
*****
*           Welcome to the IBM Db2 Analytics Accelerator Console
*****

You have the following options:

(1) - Change the Configuration Console Password
(2) - (Menu) Run Netezza Commands
(3) - (Menu) Run Accelerator Functions
(4) - (Menu) Manage Hardware
(5) - (Menu) Manage Incremental Updates
(6) - (Menu) Manage 'Call Home'
(7) - (Menu) Manage Encryption

-----
(x) - Exit the Configuration Console
```

7. Type 3 and press Enter to display the submenu:

```
main -> 3
-----
You have the following options:

(0) - Go back one level
(1) - Obtain pairing code, IP address, and port
(2) - List paired Db2 subsystems
(3) - Set resource limits for Db2 subsystems
(4) - Clear query history
(5) - Specify the priority of maintenance tasks
(6) - Set the Db2 subsystem for time synchronization
(7) - Restart accelerator process
(8) - Enable the conversion mode for 24:00:00 h values to 23:59:59 h
(9) N/A: - Disable the conversion mode for 24:00:00 h values to 23:59:59 h
(10) - Set a system-wide resource limit
```

8. Type 1 and press Enter:

9. When the message Specify for how long you want the pairing code to be valid. is displayed, enter an appropriate integer to specify the validity period in minutes.

The time that you choose must be sufficient for you or a coworker to go to the workstation that runs the administration client, start the **Add Accelerator** wizard, and enter the information that is returned by the console. Values from 5 to 1440 are allowed. If you just press Enter, you accept the default of 30 minutes.

```
Press <return> to accept the default of 30 minutes.
Cancel the process by entering 0.
```

```
Accelerator pairing information:
Pairing code   : 6048
IP address    : 203.0.113.8
Port          : 1400
Valid for     : 30 minutes

Press <return> to continue
```

Important: A pairing code is valid for a single try only. Furthermore, the code is bound to the IP address that is displayed on the console.

10. Make a note of the following information on the **console**:

- Pairing code
- IP address

- Port
11. Press Enter to return to the main menu of the console.
 12. Type x and press Enter to exit the console and close the network session.

Related tasks

Completing the authentication using the Add Accelerator wizard

To complete the authentication, you specify the IP address, the port number, and the pairing code in the **Add Accelerator** wizard.

Related information

[IBM DB2 Analytics Accelerator for z/OS: Stored Procedures Reference](#)

Completing the authentication using the Add Accelerator wizard

To complete the authentication, you specify the IP address, the port number, and the pairing code in the **Add Accelerator** wizard.

Before you begin

Make sure that the following conditions apply:

- You need privileges to run Db2 administration commands and stored procedures on z/OS. If you created a power user as suggested in the *Installation Guide*, the power user will have the required privileges.
- You have a valid pairing code. The pairing code, which is of temporary validity, can be obtained by using the IBM Db2 Analytics Accelerator Console.



Attention: Do not give ordinary users SELECT authorization on the SYSIBM.USERNAMES table because this allows the users to see the authentication information in the SYSIBM.USERNAMES.NEWAUTHID column.

About this task

You can renew the authentication for an existing accelerator without having to use a new pairing code. To do so, click the **Update** link in the **Accelerator** view.



Attention: Making a new backup of your Db2 catalog tables is strongly recommended after each authentication update because restore processes in your Db2 subsystem can make an accelerator unusable. This happens if you must restore your Db2 catalog and the backup of the catalog was made before the last update of the accelerator credentials. In this case, the latest authentication information will not be in the catalog tables of the backup, and so the accelerator can no longer be used.

For the completion of this task, the following stored procedures are run on your data server:

- SYSPROC.ACCEL_TEST_CONNECTION
- SYSPROC.ACCEL_ADD_ACCELERATOR

For information about the privileges that are required to run these procedures and further details, see the appropriate section in the *IBM Db2 Analytics Accelerator for z/OS: Stored Procedures Reference*. A link to this document is provided under **Related information** at the end of this section.

Procedure

1. Go to the folder or page that lists the accelerators:

| | |
|--------------------------------------|--|
| IBM Db2 Analytics Accelerator Studio | Select the Accelerators folder in the Administration Explorer . |
| IBM Data Server Manager | <ol style="list-style-type: none"> a. Click . b. Select > ADMINISTER > Accelerators. |

2. Start the **Add Accelerator** wizard:

| | |
|--------------------------------------|--|
| IBM Db2 Analytics Accelerator Studio | <p>a. On the menu bar of the Object List Editor, click the downward-pointing arrow next to the green plus sign.</p> <p>b. From the drop-down menu, select Add Accelerator.</p> |
| IBM Data Server Manager | Click Add . |

3. In the **Name** field, type a name for the accelerator.

This name is automatically copied to the **Location** field.

The location name is the unique name of the accelerator in the SYSIBM.LOCATIONS table. Mostly, this is the same name as the accelerator name.



Attention: If you want to connect more than one Db2 subsystem to the same accelerator, you must use a different location name for each pairing. For each IP address and port combination, the assignment to an accelerator must be logically unique. If you disregard this rule and use the same location name, you will lose the connection to the previously paired Db2 subsystem, and the data on the accelerator will be deleted. This mechanism was implemented on purpose because it ensures that a newly added accelerator is always “clean”.

4. In the **Pairing code** field, type the pairing code.

5. In the **IP address** field, type the IP address of the accelerator.

6. Specify the correct port:

| | |
|--------------------------------------|---|
| IBM Db2 Analytics Accelerator Studio | In the Port field, type 1400. This is the fixed port for network communication between the z/OS data server and the accelerator. |
| IBM Data Server Manager | The Port field is prefilled with port number 1400. Leave this as is, unless you know for sure that a different port has been configured. |

7. Click **Test Connection** to check whether the accelerator with the given address can be connected to.

Note: If the network connection between the z/OS data server and the accelerator is encrypted, an MTU (maximum transmission unit or frame size) error is reported. The message says that the maximum frame sizes on the z/OS data server and on the accelerator differ. Although the difference is real (is has to do with the IPsec implementation), you can ignore this message because the difference has no impact.

8. Click **OK**.

A connection test is carried out. See the note in step [“Completing the authentication using the Add Accelerator wizard”](#) on page 101. The note also applies here because it is the same test.

Related tasks

Obtaining the pairing code for authentication

Communication between an accelerator and a Db2 subsystem requires both components to share credentials. These credentials are generated after you submit a temporarily valid pairing code. This step is required each time you add a new accelerator. The following steps describe how to obtain the pairing code.

Related information

[IBM DB2 Analytics Accelerator for z/OS: Stored Procedures Reference](#)

[DRDA connection does not work](#)

You can ping the accelerators, but you cannot establish a distributed relational database access (DRDA) connection between your database management system and the accelerator.

Adding virtual accelerators (IBM Db2 Analytics Accelerator Studio only)

Virtual accelerators are simulators used for query testing and evaluation. Using such an accelerator, you can check whether a query can be accelerated, whether errors occur during processing, and whether the response time benefit is high enough to justify acceleration.

Before you begin

Make sure that the user running the test queries has the following privileges in Db2 for z/OS:

- SELECT, INSERT and DELETE privilege on the SYSACCEL.SYSACCELERATORS table
- SELECT, INSERT, DELETE, UPDATE privilege on the SYSACCEL.SYSACCELERATEDTABLES table
- MONITOR privilege (to display, start, and stop the virtual accelerator)
- SELECT privilege on the tables used in the test queries
- SELECT, INSERT, UPDATE and DELETE privileges on explain tables, including DSN_QUERYINFO_TABLE

Restriction: You can define virtual accelerators from IBM Db2 Analytics Accelerator Studio only. IBM Data Server Manager does not offer this option.

About this task

Virtual accelerators do not require accelerator hardware. They produce Db2 EXPLAIN information, which can be visualized in an access plan graph.

Procedure

1. Select the **Accelerators** folder in the **Administration Explorer**.
2. On the menu bar of the **Object List Editor**, click the downward-pointing arrow next to the green plus sign.
3. From the drop-down menu, select **Add Virtual Accelerator**.
4. In the **Add Virtual Accelerator** window, in the **Name** field, type a name for the virtual accelerator.
5. Click **OK**.

Results

The virtual accelerator is shown in the **Object List Editor**.

What to do next

Complete the following steps in the same way as for a regular accelerator:

1. Define accelerator-shadow tables on the virtual accelerator.
2. Enable acceleration for these tables as necessary.
3. Submit queries to the virtual accelerator.

Note: You cannot load data into a virtual accelerator.

Related tasks

[Displaying an access plan graph](#)

An access plan graph is a visual representation of a query that shows the database objects that are accessed by the query and the order in which this is done.

Displaying accelerator networking details

To display the networking details of connected accelerators, such as the host names, IP addresses, and ports used, you can issue an SQL query.

About this task

The information can be extracted from certain Db2 catalog tables and system tables:

- SYSACCEL.SYSACCELERATORS
- SYSIBM.IPNAMES
- SYSIBM.LOCATIONS

Procedure

1. In the header of the **Administration Explorer** in IBM Db2 Analytics Accelerator Studio, click the downward-pointing arrow and select **New SQL script**.
2. Copy and paste the following query in the script window on the right:

```
SELECT A.ACCELERATORNAME, A.LOCATION, I.IPADDR, L.PORT
FROM SYSACCEL.SYSACCELERATORS AS A, SYSIBM.IPNAMES AS I, SYSIBM.LOCATIONS AS L
WHERE A.LOCATION = L.LOCATION AND I.LINKNAME = L.LINKNAME;
```

3. Click .
4. If no connection profile is selected in the **Administration Explorer**, the **Select Connection Profile** window comes up. If so, select the proper database connection profile (database server) in the **Connections** list.
5. Click **Finish**.
6. Click the **Result1** tab in the lower right corner.
The requested information is displayed in a table.

Example

| ACCELERATORNAME | LOCATION | IPADDR | PORT |
|-----------------|----------|-------------|------|
| BC6 | BC6 | 203.0.113.7 | 1277 |
| TF12 | TF12 | 203.0.113.8 | 1400 |
| TF3 | TF3 | 203.0.113.9 | 1400 |

Defining tables on an accelerator

Using the **Add Tables to Accelerator** or the **Select Tables to Add** wizard, you can define accelerator-shadow tables on an accelerator.

Before you begin

- Make sure that at least one accelerator has been configured.
- Make sure that a database connection is associated with this accelerator.
- Make sure that your resource database contains tables.

About this task

Important:

- Table columns of the type CHAR and VARCHAR can be encoded in UNICODE, EBCDIC, or ASCII. By default, tables cannot co-exist on the same accelerator if columns of these types are encoded differently.

However, setting the AQT_ENABLE_MULTIPLE_ENCODING environment variable, you can define tables with EBCDIC and UNICODE columns on the same accelerator. For details and restrictions, see the documentation of this environment variable in the *IBM Db2 Analytics Accelerator for z/OS: Stored Procedures Reference*.

- IBM Db2 Analytics Accelerator for z/OS does not support EDITPROC encryption. SQL encryption and decryption functions, such as DECRYPT_CHAR(), require binary table columns, which cannot be used on an accelerator. Furthermore, data that is stored in Db2 with the EDITPROC encryption tool will not be encrypted on the hard disk of the accelerator. However, the data on an accelerator is encoded with a special algorithm for efficient compression and therefore cannot be easily extracted from the media.

This task is carried out by the SYSPROC.ACCEL_ADD_TABLES stored procedure on your data server. For information about the privileges that are required to run this procedure and further details, see the appropriate section in the *IBM Db2 Analytics Accelerator for z/OS: Stored Procedures Reference*. A link to this document is provided under **Related reference** at the end of this section.

Procedure

- Open the list of accelerators:

| | |
|--------------------------------------|--|
| IBM Db2 Analytics Accelerator Studio | In the Administration Explorer , go to the Accelerators folder. |
| IBM Data Server Manager | <ol style="list-style-type: none"> Click  in the upper left. Select ADMINISTER > Accelerators. |

- Select the accelerator that you want to add tables to:

| | |
|--------------------------------------|---|
| IBM Db2 Analytics Accelerator Studio | <ol style="list-style-type: none"> In the Object List Editor, double-click the accelerator name. In the Accelerator view, click Add on the toolbar, which is located above the list of tables. |
| IBM Data Server Manager | <ol style="list-style-type: none"> Select a row in the list of accelerators. Click the Manage button on the toolbar. Click the Add button on the toolbar. |

- If the list is long, narrow the choice by using a filter.

| | |
|--------------------------------------|---|
| IBM Db2 Analytics Accelerator Studio | <p>In the Add Tables to Accelerator window, you see a list of all available schemas and tables under Available tables.</p> <p>Type the names of schemas or tables in the Name like filter field, either fully or partially, to display just schemas and tables bearing or starting with that name. The names of tables that have already been selected are grayed out.</p> |
| IBM Data Server Manager | In the Select Tables to Add window, you see a list of all available schemas and tables. |





| | |
|--|---|
| | <p>Click  to display the search field. Type the names of schemas or tables in the search field, either fully or partially, to display just schemas and tables containing your search string. The names of tables that have already been selected are grayed out.</p> |
|--|---|

4. Select the tables.

The list of selectable items is organized hierarchically. At first, you might only see the available schemas. If you click the twistie in front of a schema name, the tables belonging to the schema come into view.

You cannot select accelerator-only tables because these tables already exist on an accelerator. Entries for these tables are listed, but are grayed out. Apart from the different icon, you find the information *already added* in parentheses to identify the table as an accelerator-only table. Remember that accelerator-only tables are created by a `CREATE TABLE . . . IN ACCELERATOR` SQL statement.

The **Unsupported Columns** column lists the unsupported columns in each Db2 table (if any). If possible, do not select tables with unsupported columns because such columns are not loaded on the accelerator. Queries referencing such columns cannot be accelerated. In most cases, a column is not supported because its data type cannot be handled by IBM Db2 Analytics Accelerator for z/OS.

| | |
|---|---|
| <p>IBM Db2 Analytics Accelerator Studio</p> | <ul style="list-style-type: none"> • To define a single table on the selected accelerator, select its name under Available tables, in the Name column, and click  to move the column to the Tables to be added list. To select multiple tables, hold down the CTRL key and click the names of the tables that you want to add. To move all visible tables to the Tables to be added list, click . • To correct your choice and remove a table from the Tables to be added list, select it in the Name column of that list and click  to move the table back to the Available tables list. To remove all tables from the Tables to be added list, click . <p>Note: Detecting unsupported columns takes a long time if IBM Db2 Analytics Accelerator Studio has to connect to a database with numerous tables. To save this time, you can suppress the display of unsupported columns. To do so, go to Window > Preferences > IBM Db2 Analytics Accelerator > Accelerator View and clear the Check for unsupported columns check box.</p> |
| <p>IBM Data Server Manager</p> | <ul style="list-style-type: none"> • To add all schemas (including all tables), select the check box in front of the column label SCHEMA NAME. • To add all tables belonging to a schema, select the check box in front of a schema name. • To add individual tables, click the twistie in front of a schema name to expand the list of |

| | |
|--|---|
| | tables belonging to that schema. Then select the check box in front of one or more table names. |
|--|---|

If a Db2 source table was created after IBM Db2 Analytics Accelerator Studio connected to a Db2 subsystem on the data server, you might be unable to locate this table in the list. In such a case, click the refresh button:

| | |
|--------------------------------------|---|
| IBM Db2 Analytics Accelerator Studio |  |
| IBM Data Server Manager |  |

In IBM Db2 Analytics Accelerator Studio, the problem can also occur if you have defined a filter in the **Administration Explorer** or in the **Properties** section of a database connection profile. If so, proceed as follows:

- a. Close the **Add Tables** window.
 - b. Remove the filter.
 - c. Reopen the **Add Tables** window.
 - d. Click .
5. Confirm by closing the **Add Tables** or **Select Tables to Add** wizard.

| | |
|--------------------------------------|-----------------------|
| IBM Db2 Analytics Accelerator Studio | Click Finish . |
| IBM Data Server Manager | Click OK . |

Related tasks

[Preparing tables for workload balancing and accelerating static SQL queries](#)

You need not enable workload balancing or static SQL support. However, the development of these features made it necessary to introduce a new naming scheme for tables. So if you have accelerator-shadow tables that were defined with older versions of IBM Db2 Analytics Accelerator for z/OS and want to use workload balancing or accelerate static SQL queries, you must either migrate, or, if this is not possible, remove and then redefine those tables.

Related information

[IBM DB2 Analytics Accelerator for z/OS: Stored Procedures Reference](#)

Determining the status of an accelerator

See how to check the status of an accelerator.

Before you begin

- A database connection profile must exist for the database that is associated with the accelerator.
- You (your user ID) must be connected to the database.

About this task

This task is carried out by the SYSPROC.ACCEL_CONTROL_ACCELERATOR stored procedure on your data server. For information about the privileges that are required to run this procedure and further details, see the appropriate section in the *IBM Db2 Analytics Accelerator for z/OS: Stored Procedures Reference*. A link to this document is provided under **Related reference** at the end of this section.

Procedure

1. Start your administration client.

2. Select the accelerator:

| | |
|--------------------------------------|--|
| IBM Db2 Analytics Accelerator Studio | <ol style="list-style-type: none"> In the Administration Explorer, select the Accelerators folder. In the Object List Editor, double-click an accelerator name to open the corresponding Accelerator view. |
| IBM Data Server Manager | <ol style="list-style-type: none"> Click  in the upper left. Select ADMINISTER > Accelerators. In the list of accelerators, select the name of the accelerator (row). |

3. View the status:

| | |
|--------------------------------------|--|
| IBM Db2 Analytics Accelerator Studio | The status is displayed on top of the page that is displayed. |
| IBM Data Server Manager | The Acceleration Status of the selected accelerator is displayed in the lower half of the window. |

Related tasks

[Enabling an accelerator](#)

Queries can only be routed to an accelerator if the accelerator has been enabled in Db2 for z/OS.

Related information

[IBM DB2 Analytics Accelerator for z/OS: Stored Procedures Reference](#)

Enabling an accelerator

Queries can only be routed to an accelerator if the accelerator has been enabled in Db2 for z/OS.

Before you begin

- You need a connection to a database that has an accelerator attached to it.
- You (your user ID) must be connected to the database and have the rights to control the accelerator.
- The **Acceleration** status of the accelerator must be *Stopped*.

Procedure

Use one of the following methods to enable an accelerator:

- On the command-line in Db2 for z/OS, enter `-start ACCEL <name>` where <name> is the name of the accelerator.
- In your administration client:
 - a) Select the accelerator:

| | |
|--------------------------------------|--|
| IBM Db2 Analytics Accelerator Studio | <ol style="list-style-type: none"> In the Administration Explorer, select the Accelerators folder. In the Object List Editor, double-click an accelerator name to open the corresponding Accelerator view. |
|--------------------------------------|--|

| | |
|-------------------------|--|
| IBM Data Server Manager | <ol style="list-style-type: none"> Click  in the upper left. Select ADMINISTER > Accelerators. In the list of accelerators, select the name of the accelerator (row). |
|-------------------------|--|

b) Click the start button:

| | |
|--------------------------------------|--|
| IBM Db2 Analytics Accelerator Studio | Click  on the toolbar. |
| IBM Data Server Manager | Click the Start button on the toolbar. |

This invokes the Db2 command **-START ACCEL** on your data server.

Results

When an accelerator has been enabled, its acceleration status changes to *Started*.

Related tasks

Disabling an accelerator

You can disable an accelerator to prevent the routing of queries to this accelerator.

Disabling an accelerator

You can disable an accelerator to prevent the routing of queries to this accelerator.

Before you begin

- You need a connection to a database that has an accelerator attached to it.
- You (your user ID) must be connected to the database and have the rights to control the accelerator.
- The status of the accelerator must be *Online*.

About this task

Disabling an accelerator is recommended, for example, before you update software on the data server or on the accelerator. You can also disable an accelerator temporarily to compare response time. During the disablement, all queries are processed by Db2. You might also want to disable an accelerator for maintenance tasks. However, it is not necessary to disable an entire accelerator for maintaining accelerator-shadow tables; each table can be disabled individually.





Procedure

- On the command-line in Db2 for z/OS, enter `-stop ACCEL <name>` where <name> is the name of the accelerator.
- In your administration client:
 - a) Select the accelerator:

| | |
|--------------------------------------|--|
| IBM Db2 Analytics Accelerator Studio | <ol style="list-style-type: none"> In the Administration Explorer, select the Accelerators folder. In the Object List Editor, double-click an accelerator name to open the corresponding Accelerator view. |
| IBM Data Server Manager | <ol style="list-style-type: none"> Click  in the upper left. Select ADMINISTER > Accelerators. |

| | |
|--|---|
| | c. In the list of accelerators, select the name of the accelerator (row). |
|--|---|

b) Stop the accelerator:

| | |
|--------------------------------------|--|
| IBM Db2 Analytics Accelerator Studio | <ul style="list-style-type: none"> – Click  to disable the selected accelerator without canceling running queries. The accelerator status first changes to <i>Stopping</i>, then to <i>Stopped</i>. During the <i>Stopping</i> phase, running queries are completed. – Click the  button on the right of the  button and select Force from the menu to disable the selected accelerator and cancel all running queries. The status of the accelerator changes to <i>Stopped</i> immediately. <p>Note: Clicking the stop button does not make an accelerator unusable or remove it from the configuration. It just deactivates it. To restart an accelerator, click the  button on the toolbar.</p> |
| IBM Data Server Manager | <p>Click the Stop button on the toolbar. The accelerator status first changes to <i>Stopping</i>, then to <i>Stopped</i>. During the <i>Stopping</i> phase, running queries are completed.</p> <p>Note: Clicking the stop button does not make an accelerator unusable or remove it from the configuration. It just deactivates it. To restart an accelerator, click the Start button on the toolbar.</p> |

Preparing tables for workload balancing and accelerating static SQL queries

You need not enable workload balancing or static SQL support. However, the development of these features made it necessary to introduce a new naming scheme for tables. So if you have accelerator-shadow tables that were defined with older versions of IBM Db2 Analytics Accelerator for z/OS and want to use workload balancing or accelerate static SQL queries, you must either migrate, or, if this is not possible, remove and then redefine those tables.

Before you begin

Version 4 PTF-2 of the product introduces the SYSPROC.ACCEL_MIGRATE stored procedure, which converts existing table names in accordance with the new naming scheme. Running the stored procedure is less effort than removing, redefining, reloading, and re-enabling the accelerator-shadow tables, so consider upgrading the product to version 4 PTF-2 or later.

About this task

To support workload balancing and static SQL, it became necessary to change the naming scheme for tables in the SYSACCEL.SYSACCELERATEDTABLES catalog table. Older entries in this catalog table do not provide the additional information that is required for a successful use of these features. Migrate the table names by using the appropriate method for your version of the product:

Procedure

- If version 4 PTF-2 or later has been installed, run the SYSPROC.ACCEL_MIGRATE stored procedure against each accelerator that is supposed to participate in your workload balancing or static SQL scenario.

The stored procedure always migrates the names of all tables on an accelerator.

Important:

- If you want to accelerate static SQL queries in a workload balancing environment, run the stored procedure before you bind the static packages. Otherwise, you will have to rebind the packages after the table name migration.
- The query history (**Show Plan** function) in IBM Db2 Analytics Accelerator Studio might show unexpected table names after the migration. This is normal.

For instructions on the use of the stored procedure, follow the **Related reference** link at the end of this topic.

- If you still use version 4 PTF-1, complete the following steps:
 - a) To find the tables that do not yet use the new naming scheme, submit the following query:

```
SELECT ACCELERATORNAME, CREATOR, NAME, SUPPORTLEVEL
FROM SYSACCEL.SYSACCELERATEDTABLES
WHERE SUPPORTLEVEL < 3;
```

- b) Remove the accelerator-shadow tables that are listed in the query output from all accelerators.
- c) Redefine these tables on as many accelerators as required.
- d) Load the redefined accelerator-shadow tables.
- e) Enable query acceleration for the redefined accelerator-shadow tables.

Related concepts

Static SQL query support

Static SQL query support means that you can now accelerate SQL queries that are embedded within Db2 for z/OS application programs. Older versions of IBM Db2 Analytics Accelerator for z/OS could not accelerate such queries.

Workload balancing

Workload balancing can be described as follows: If more than one accelerator is connected to a Db2 subsystem, and the tables that are referenced in a query are defined on multiple accelerators, IBM Db2 Analytics Accelerator for z/OS automatically picks the accelerator with the lowest utilization for processing.

Related information

[IBM DB2 Analytics Accelerator for z/OS: Stored Procedures Reference](#)

Enabling or disabling an accelerator for members of a data sharing group

If an accelerator is attached to a Db2 data sharing group, you can enable or disable acceleration individually for each member of the group.

Procedure

1. In the **Administration Explorer**, select the **Accelerators** folder.
2. In the **Object List Editor**, double-click an accelerator to open the **Accelerator** view.
3. In the header of the Accelerator view, next to the **Acceleration** status, click the **Change** link.
4. The **Start / Stop Acceleration** window lists all members of the data sharing group and shows their acceleration status. To enable or disable the accelerator for members of the data sharing group, select the appropriate check boxes in front of the member names.

If the group contains many members, you can speed up the process by using the **Select All** and **Deselect All** buttons.

5. Click one of the following buttons on top of the list:

Start

To enable the accelerator for the selected members

Stop

To disable the accelerator for the selected members

Stop Force

To disable the accelerator immediately, that is, without waiting for the completion of not yet finished queries.

6. Click **Close** when finished or **Cancel** to close the window without making changes.

Loading tables

Successful queries against accelerator-shadow tables are possible only if the tables contain data. Therefore, you must load the tables after their definition (empty structure) has been copied to the accelerator.

Before you begin

- A database connection profile must exist for the database that is associated with the accelerator.
- You (your user ID) must be connected to the database. Your user ID requires privileges to:
 - Control the accelerator
 - Read the data to be loaded into the accelerator
- The accelerator-shadow tables that you want to load or update must exist on the accelerator.
- The following procedure is not for accelerator-only tables. To load accelerator-only tables, you have to use INSERT statements. These can be submitted from Db2 for z/OS directly, from various client programs using ODBC or JDBC connections, or from application programs with embedded (static) SQL code.

About this task

Loading accelerator-shadow tables can take a long time (for example minutes or hours) depending on the amount of data in the original Db2 tables.

The disk throughput can be quite volatile, depending on the disk configuration, the placement of data sets, the number of parallel I/O operations, and so on. To a large extent, the throughput depends on the following factors:

- Partitioning of tables in your Db2 subsystem. In Db2 for z/OS, this determines the degree of parallelism that can be used internally by the Db2 Unload Utilities.
- Number of DATE, TIME, and TIMESTAMP columns in your original table. The conversion of the values in such columns is CPU-intensive.
- Compression of data in Db2 for z/OS.
- Number of available processors.
- Workload Manager (WLM) configuration.
- Workload on the zEnterprise® server.
- Workload on the accelerators.

Restrictions:

- A load fails if names of table columns start with a special character, that is, column names must start with a character from 0-9, a-z, or A-Z.
- IBM Db2 Analytics Accelerator for z/OS does not support EDITPROC encryption. SQL encryption and decryption functions, such as DECRYPT_CHAR(), require binary table columns, which cannot be used on an accelerator. Furthermore, data that is stored in Db2 with the EDITPROC encryption tool will not be encrypted on the hard disk of the accelerator. However, the data on an accelerator is encoded with a special algorithm for efficient compression and therefore cannot be easily extracted from the media.
- During a load process, you cannot close IBM Db2 Analytics Accelerator Studio or the database connection before the loading has finished.
- Incremental updates are not restarted automatically if you enable these for just one table and complete the enablement steps in this order:
 1. Define the accelerator-shadow table.
 2. Enable incremental updates for this table.
 3. Load the accelerator-shadow table.
 4. Start incremental updates (**Replication > Start**).
 5. Reload the accelerator-shadow table.

Normally, when this is done for more than one table, incremental updates continue or are restarted for all tables that are not being loaded or where loading has been finished, which finally results in an automatic restart for all tables. In this special case (just one table), however, you must restart incremental updates manually after the reload.

- After a load, a replication-enabled accelerator-shadow table goes into *Suspended* state if the following conditions apply:
 - *Continuous incremental updates* are enabled.
 - Someone has stopped replication during the load.

Suspended means that the table is skipped when incremental updates are applied. To make this table part of the incremental update process again, you must reload it.

You can also integrate the loading and updating of accelerator-shadow tables into your scheduled ETL processes by invoking the SYSPROC.ACCEL_LOAD_TABLES stored procedure directly from a job that is run by your preferred scheduler (for example, Tivoli® workload scheduler).

Table loading is carried out by the SYSPROC.ACCEL_LOAD_TABLES stored procedure on your data server. In addition, the SYSPROC.ACCEL_SET_TABLES_ACCELERATION stored procedure is invoked to enable acceleration for the loaded table.

For information about the privileges that are required to run these procedures and further details, see *Appendix C. Required access rights* in the *IBM Db2 Analytics Accelerator for z/OS: Stored Procedures Reference*. A link to this document is provided under **Related information** at the end of this section.

Procedure

1. Select an accelerator:

| | |
|--------------------------------------|---|
| IBM Db2 Analytics Accelerator Studio | <ol style="list-style-type: none"> a. In the Administration Explorer, select the Accelerators folder. b. In the Object List Editor, double-click the accelerator containing the tables that you want to load. |
| IBM Data Server Manager | <ol style="list-style-type: none"> a. Click  in the upper left. b. Select ADMINISTER > Accelerators. c. In the list of accelerators, select the accelerator containing the tables you want to load. d. Click Manage. |

2. You see a list of the tables on the accelerator. Select the accelerator-shadow tables that you want to load.

To see the tables, you might have to expand the schema nodes first, by clicking the plus sign in front of a schema name. Selecting an entire schema will select all accelerator-shadow tables belonging to that schema for loading.

3. Click the **Load** button on the toolbar.

The list in the **Load Tables** window contains a column labeled **Load Recommended**. The information in this column is supposed to help you with the selection. Because table loads are long-running processes, only load or reload an accelerator-shadow table or partition when necessary.

Important:

- You can only select table partitions if the tables are partitioned by range or partitioned by growth, and if they were already loaded in the past. In all other cases, you can only load entire tables.
- The information in the **Load Recommended** column might be inaccurate if Db2 realtime statistics are not up-to-date (RUNSTATS) or if incremental updates have been applied to the accelerator-shadow table since the last load.

The **Load Recommended** column contains one of the following statuses for each table or partition:

No - data unchanged

Table or partition data has not changed in Db2 for z/OS. Therefore, you need not load or reload the accelerator-shadow table or partition.

Yes - changed data

A load or reload of the accelerator-shadow table or partition is recommended because data changes have been applied to the original Db2 for z/OS tables.

Unknown - no statistics

A load or reload of the accelerator-shadow table or partition is recommended because the current status of the table or partition cannot be determined. It must therefore be assumed that the table is out of sync. The reason might be that access to Db2 statistics is not available or that the last successful invocation of RUNSTATS was some time ago.

Unknown - replication enabled

Data changes have been detected since the last load of the accelerator-shadow table, but the table is currently enabled for incremental updates. The data changes are propagated asynchronously by the incremental update function, but it can not be determined whether the table is already in sync. A reload is usually not required under this condition.

Yes - enforced

A partition with a value of **Yes - enforced** in the **Load Recommended** column will always be loaded if the entire accelerator-shadow table is selected for loading. A possible reason is that the partition is in *InitialLoadPending* state because it has never been loaded before.

If the list of tables and partitions is long, you can apply a filter to hide certain items from the display. To do so, select a different value from the **Show recommended** drop-down list (in IBM Data Server Manager, this drop-down list has no label). The following choices are available:

All (default)

Displays all accelerator-shadow tables and partitions.

All recommended

Displays only the accelerator-shadow tables and partitions for which a load or reload is recommended.

No - data unchanged

Displays only the accelerator-shadow tables and partitions that need not be loaded or reloaded.

Yes - changed data

Displays only the accelerator-shadow tables and partitions for which a load or reload is recommended because data in the original tables has changed.

Unknown - no statistics

Displays only the accelerator-shadow tables and partitions for which a load or reload is recommended because the status cannot be determined.

Yes - enforced

Displays only the accelerator-shadow tables and partitions for which a load or reload will be enforced.

4. Select the appropriate tables or partitions.

| | |
|--------------------------------------|---|
| IBM Db2 Analytics Accelerator Studio | <p>Select the appropriate check boxes in front of the table or partition names, or use the buttons on the right:</p> <p>Select All Selects all tables and partitions that are shown in the Load Tables window.</p> <p>Deselect All Deselects all tables and partitions.</p> <p>Select Recommended Selects all accelerator-shadow tables and partitions for which a load or reload is recommended in the Load Recommended column.</p> <p>Expand All Expands all table nodes so that the partitions come into view.</p> <p>Collapse All Collapses all table nodes so that the table partitions are hidden from view.</p> <p>Next Unknown Jumps to and selects the next accelerator-shadow table or partition with a status of Unknown - no statistics in the Load Recommended column. This might prove useful if the list is crowded.</p> |
| IBM Data Server Manager | Select the appropriate check boxes in front of the table or partition names. |

| | |
|--|---|
| | To quickly select just the tables and partitions for which a load is recommended, click the Select Recommended button. |
|--|---|

5. Select **Lock DB2 tables while loading** if you want to protect (lock) the original tables or table partitions in the database against changes during the load operation:

All Tables

Protects the Db2 source tables of the tables to be loaded against changes during the load operation.

Current Table

Protects just the Db2 source table of the table that is currently being loaded.

Current Partitions

Protects the Db2 table-space partition containing the part of the of the source table that is currently being loaded. With this setting, an unpartitioned table is always locked completely.

Current Row

Protects at least the row or page that is being loaded against updates. Whether a row, a page, or an entire table is locked is determined by the LOCKSIZE defined for the table space of the source tables. (For more information, see the Db2 documentation for the CREATE TABLESPACE command. You find a link at the end of this topic.) When lock mode ROW is set, Db2 data is unloaded at isolation level CS (cursor stability), but in contrast to lock mode NONE, rows locked by an application are not skipped. This is the recommended choice for loads in connection with *continuous incremental updates*.



Attention: This lock mode might lead to a loss of not yet transferred changes if *continuous incremental updates* are not enabled. This is because a load stops "ordinary" incremental updates, and a new capture point (point in time after which table changes are monitored) is not set before load completion. If table rows are locked for the unloading of row data and unlocked shortly after, when the process moves on to the next row, unmonitored row changes can occur. Such changes would be lost.

Therefore, use lock mode **Row** only if you have enabled *continuous incremental updates* because this type of incremental updates saves all changes not yet applied to a spill queue, which is emptied after the load (changes that occurred before the setting of the capture point are applied at a later time).

To avoid deadlocks during the draining of the spill queue, set the table space of the source tables to LOCKSIZE ROW. For more information, see *Enabling continuous incremental updates* in the *IBM Db2 Analytics Accelerator for z/OS: Installation Guide*.

If you want to use this lock mode in a different context, contact IBM support before doing so.

NONE

No locking at all. However, only committed data is loaded into the accelerator-shadow tables because the Db2 data is unloaded with isolation level CS and SKIP LOCKED DATA.

6. The option **After load, enable acceleration for disabled tables** ensures that you can run accelerated queries against all accelerator-shadow tables immediately after the completion of the load operation. It is selected by default. Deselect it only if there is a good reason to do so.

The following scenario is thinkable: the table is big and one or more columns could not be loaded because their data type is not supported. These columns, however, would have held the crucial data. In this case, it makes perfect sense to switch the option off to prevent a waste of processing resources.

7. Click **OK**.

Note: If the load fails, first check whether DSNUTIL was started in Db2 for z/OS.

Related concepts

[Accelerator-only tables and in-database transformation](#)

Accelerator-only tables are tables that do not originate from Db2 base tables. Their data exists only on an accelerator. Data in accelerator-only tables can only be modified by data-manipulation (DML) statements (INSERT, UPDATE, and DELETE). With accelerator-only tables, you can do in-database transformation (IDT) in a more efficient way.

Updating accelerator tables continually

The incremental update function of IBM Db2 Analytics Accelerator for z/OS allows you to update accelerator-shadow tables continually. Changes to the data in original Db2 for z/OS tables are thus propagated to the corresponding target tables with a high frequency and just a brief delay. This way, query results from an accelerator are always extracted from recent, close-to-real-time data.

Related tasks

Preparing tables for workload balancing and accelerating static SQL queries

You need not enable workload balancing or static SQL support. However, the development of these features made it necessary to introduce a new naming scheme for tables. So if you have accelerator-shadow tables that were defined with older versions of IBM Db2 Analytics Accelerator for z/OS and want to use workload balancing or accelerate static SQL queries, you must either migrate, or, if this is not possible, remove and then redefine those tables.

Related information

[IBM DB2 Analytics Accelerator for z/OS: Stored Procedures Reference](#)
[IDLE THREAD TIMEOUT field \(IDTHTOIN subsystem parameter\)](#)

Enabling tables for query acceleration

You can permit or prevent the sending of queries to an accelerator by enabling or disabling the corresponding accelerator-shadow tables.

Before you begin

- You need a connection to a database that has an accelerator attached to it.
- You (your user ID) must be connected to the database and have the rights to control the accelerator.
- The tables must have been defined on the accelerator.

About this task

After its creation, an accelerator-shadow table is in *load pending* state. Query acceleration is disabled for tables in this state. The *load pending* state is also reached when an error has led to an operation failure. Also, when data has been loaded into a table, the table is not automatically enabled. Therefore, you must enable the table so that it becomes *active* and will thus be used in accelerated queries. You can disable or re-enable a loaded accelerator-shadow table by switching query acceleration for this table on or off. To enable a table, the table must be in *loaded* or *update in progress* state.

If partitions of a table have been archived by the High Performance Storage Saver, these partitions no longer belong to the regular accelerator-shadow table. Enabling this table for accelerated queries will thus not enable the archived partitions. To include archived partitions in accelerated queries, use the GET_ACCEL_ARCHIVE special register in your queries or set this option as a ZPARM.

Tip: If you want to disable all tables, you better stop the entire accelerator. For more information, see the link under **Related tasks** at the end.

The task of enabling tables for query acceleration is carried out by the SYSPROC.ACCEL_SET_TABLES_ACCELERATION stored procedure on your data server. For information about the privileges that are required to run this procedure and further details, see the appropriate section in the *IBM Db2 Analytics Accelerator for z/OS: Stored Procedures Reference*. A link to this document is provided under **Related reference** at the end of this section.

When an accelerator-shadow table has been enabled, the corresponding entry in the ENABLED column of the system table SYSACCEL.SYSACCELERATEDTABLES is set to ON. Although an accelerator-shadow table

can exist on more than one accelerator, it can be enabled on one accelerator only. If a table is in a state that does not permit enabling, the operation ends abnormally and the enablement is canceled.

Important:

- Query acceleration can be always disabled regardless of the state an accelerator-shadow table is in. This is useful if you need to recover from an error situation in which an accelerator is down or unreachable.
- You might have to reload or even remove tables from an accelerator after the execution of an ALTER TABLE or ALTER TABLESPACE statement in Db2 for z/OS. For more information, see *What to do after changing a table or table space in Db2 for z/OS*. You find a **Related reference** link at the end of this topic.

Procedure

1. Select an accelerator:

| | |
|--------------------------------------|--|
| IBM Db2 Analytics Accelerator Studio | <p>a. In the Administration Explorer, select the Accelerators folder.</p> <p>b. In the Object List Editor, double-click the accelerator containing the tables that you want to enable.</p> |
| IBM Data Server Manager | <p>a. Click  in the upper left.</p> <p>b. Select ADMINISTER > Accelerators.</p> <p>c. In the list of accelerators, select the accelerator containing the tables you want to enable.</p> <p>d. Click Manage.</p> |

2. Select the tables you want to enable. In IBM Db2 Analytics Accelerator Studio, you might have to scroll down to the list of tables.

3. Enable acceleration for the selected tables:

| | |
|--------------------------------------|---|
| IBM Db2 Analytics Accelerator Studio | Select Acceleration > Enable from the toolbar. |
| IBM Data Server Manager | Select Acceleration > Enable Acceleration from the toolbar. |

Results

Queries against these tables are accelerated if the associated accelerator has been started.

Related tasks

Disabling query acceleration for tables

You can disable accelerated queries against selected tables without entirely disabling the associated accelerator.

Loading tables

Successful queries against accelerator-shadow tables are possible only if the tables contain data. Therefore, you must load the tables after their definition (empty structure) has been copied to the accelerator.

Preparing tables for workload balancing and accelerating static SQL queries

You need not enable workload balancing or static SQL support. However, the development of these features made it necessary to introduce a new naming scheme for tables. So if you have accelerator-shadow tables that were defined with older versions of IBM Db2 Analytics Accelerator for z/OS and want to use workload balancing or accelerate static SQL queries, you must either migrate, or, if this is not possible, remove and then redefine those tables.

Disabling an accelerator

You can disable an accelerator to prevent the routing of queries to this accelerator.

Related reference

What to do after changing a table or table space in Db2 for z/OS

In a number of cases, an ALTER TABLE or ALTER TABLESPACE statement in Db2 for z/OS does not involve maintenance work on your accelerator-shadow tables. There are cases, however, in which it does. See which steps you might have to take.

Related information

[IBM DB2 Analytics Accelerator for z/OS: Stored Procedures Reference](#)

Disabling query acceleration for tables

You can disable accelerated queries against selected tables without entirely disabling the associated accelerator.

Before you begin

- You need a connection to a database that has an accelerator attached to it.
- You (your user ID) must be connected to the database and have the rights to control the accelerator.
- The tables that you want to disable must have been added to the accelerator.

About this task

The task of disabling tables is carried out by the SYSPROC.ACCEL_SET_TABLES_ACCELERATION stored procedure on your data server. For information about the privileges that are required to run this procedure and further details, see the appropriate section in the *IBM Db2 Analytics Accelerator for z/OS: Stored Procedures Reference*. A link to this document is provided under **Related reference** at the end of this section.

Procedure

1. Select an accelerator:

| | |
|--------------------------------------|---|
| IBM Db2 Analytics Accelerator Studio | <ol style="list-style-type: none">a. In the Administration Explorer, select the Accelerators folder.b. In the Object List Editor, double-click the accelerator containing the tables that you want to disable. |
| IBM Data Server Manager | <ol style="list-style-type: none">a. Click  in the upper left.b. Select ADMINISTER > Accelerators.c. In the list of accelerators, select the accelerator containing the tables you want to disable.d. Click Manage. |

2. Select the tables you want to disable. In IBM Db2 Analytics Accelerator Studio, you might have to scroll down to the list of tables.
3. Disable acceleration for the selected tables:

| | |
|--------------------------------------|--|
| IBM Db2 Analytics Accelerator Studio | Select Acceleration > Disable from the toolbar. |
| IBM Data Server Manager | Select Acceleration > Disable Acceleration from the toolbar. |

Results

This disables query acceleration for the selected tables only. Other tables that are associated with the same accelerator are not affected.

Related information

[IBM DB2 Analytics Accelerator for z/OS: Stored Procedures Reference](#)

Specifying or changing a distribution key or organizing keys

Distribution and organizing keys have a considerable impact on the query response time.

About this task

Distribution keys and organizing keys can influence the query response time positively as well as negatively. Therefore, make sure that you only select such keys when necessary, and that you select a proper key.

Distribution key: The default is not to use a distribution key, but to distribute the data (table rows) evenly among the processing nodes. This is what the **Random distribution without a distribution key** check box signifies. If **Random distribution without a distribution key** is selected, all table rows are distributed sequentially to the processing nodes (random distribution) so that each node receives an equal share of the workload. To distribute the data evenly is usually the best choice for small and medium-sized tables, so do not change the setting unless incoming queries demand big tables to be joined.

To execute a join, data might have to be transferred over the network, which slows down the process. In such a case, it might be better to use a distribution key. If you select a join column as the distribution key for all tables involved, you assign the rows of these tables to the same processing node. This has the effect that no data needs to be transferred to execute the join.

In general, unique key columns, such as primary keys or columns with a unique index, are a good choice for a distribution key because all values are distinct. Columns that allow NULL as a value are not a good choice if many NULL values can be expected. The reason is that all rows with a NULL in the specified column will end up on the same processing node.

Tip: If you cannot assess the distribution of values in table columns, start with random distribution. If you witness a slow performance, try using a few of the recommended columns as the distribution key. Always use as few columns as possible in a distribution key.

Organizing keys: An organizing key further enhances the performance in that it sorts table rows into blocks with equal values in the selected columns. The query engine can thus process incoming rows more quickly, as less time is required to scan the rows. Since the rows are distributed for processing in blocks, entire blocks can be skipped if the value in a particular column does not match a selection criterion specified in the query. It is not necessary to scan the entire accelerator-shadow table on disk.

Organizing keys must be columns that can be referenced in zone maps. By default, an accelerator creates zone maps for columns of the following data types:

- Integers (SMALLINT, INT, BIGINT)
- DATE
- TIMESTAMP

In addition, an accelerator creates zone maps for columns of the following data types if columns of this type are used as organizing keys:

- CHAR (all sizes, but only the first eight bytes are used in the zone map)
- VARCHAR (all sizes, but only the first eight bytes are used in the zone map)
- DECIMAL (up to 18 digits)
- REAL
- DOUBLE
- TIME

Important: An organizing key has no effect if the table is too small. The **Organized** column in the **Accelerator** view reflects this by not showing a value for the degree of organization (percentage).

This task of altering or changing distribution keys or organizing keys is carried out by the SYSPROC.ACCEL_ALTER_TABLES stored procedure on your data server. For information about the privileges that are required to run this procedure and further details, see the appropriate section in the *IBM Db2 Analytics Accelerator for z/OS: Stored Procedures Reference*. A link to this document is provided under **Related reference** at the end of this section.

Procedure

1. Select the accelerator:

| | |
|--------------------------------------|--|
| IBM Db2 Analytics Accelerator Studio | <ol style="list-style-type: none"> In the Administration Explorer, select the Accelerators folder. In the Object List Editor, double-click an accelerator name to open the corresponding Accelerator view. |
| IBM Data Server Manager | <ol style="list-style-type: none"> Click  in the upper left. Select ADMINISTER > Accelerators. In the list of accelerators, select the name of the accelerator (row). Click Manage. |

2. Select a table that contains the columns to be used as a distribution key or as organizing keys:

| | |
|--------------------------------------|--|
| IBM Db2 Analytics Accelerator Studio | Select such a table in the list of schemas and tables in the Accelerator view. You might have to scroll down to view the list. |
| IBM Data Server Manager | <ol style="list-style-type: none"> Expand the twistie in front of the schema (name) the table belongs to. Select the check box in front of the table name. |

3. Click **Alter Keys** button on the toolbar.

| | |
|--------------------------------------|---|
| IBM Db2 Analytics Accelerator Studio | <p>You see the Alter Distribution or Organizing Keys window.</p> <p>The list on the left has a Recommendation column, which suggests certain columns to be used in a distribution key or as organizing keys. Suggestions are made on the basis of a previous run of Db2 RUNSTATS. So if no recommendations can be seen, use RUNSTATS and then return to the Alter Distribution or Organizing Keys window.</p> <p>RUNSTATS also calculates the column cardinality (Cardinality in the selection list). This is the number of distinct values in a column. The higher this number, the better a column is suited as a distribution key.</p> |
|--------------------------------------|---|

| | |
|-------------------------|---|
| IBM Data Server Manager | <p>You see the Alter Distribution and Organizing Keys window.</p> <p>The list of table columns contains a RECOMMENDED column, which suggests certain columns to be used in a distribution key or as organizing keys. Suggestions are made on the basis of a previous run of Db2 RUNSTATS. So if no recommendations can be seen, use RUNSTATS and then return to the Alter Distribution and Organizing Keys window.</p> |
|-------------------------|---|

Important: The RUNSTATS utility cannot collect statistics for accelerator-only tables because the data of this type of table does not reside in Db2. Hence key recommendations that rely on Db2 statistics cannot be given. You only find key recommendations for accelerator-only tables if these can be derived from the column data type.

4. To specify a distribution key:

| | |
|--------------------------------------|--|
| IBM Db2 Analytics Accelerator Studio | <ol style="list-style-type: none"> a. Clear the Random distribution without a distribution key check box. This enables the controls for the definition of a distribution key. b. In the Alter Distribution or Organizing Keys window, you see a list of the columns in the selected table. To specify a column as the distribution key or as part of it, select the column in the list and click the right-arrow button. <p>The Name like filter field makes it easier to find particular columns if the list is long. Type a column name in this field, either fully or partially, to display just the columns bearing or starting with that name. The names of columns that are currently selected as keys are grayed out.</p> <p>Selected columns appear in the upper list box on the right. You can remove a selected column by first selecting it in this box, and then clicking the left-arrow button.</p> <p>Using the buttons with the upward-pointing and downward-pointing arrows, you can change the order of the columns in the key. The order of the columns in the list has an influence on the hash value that is calculated to determine the target processing node. To place the rows of joined tables on the same processing node, the distribution keys of all tables must yield the same hash value. It is therefore important to specify the distribution key columns for all tables in the same order.</p> c. Repeat this step to add further columns to the key. A maximum of four columns is allowed. |
|--------------------------------------|--|

| | |
|-------------------------|---|
| IBM Data Server Manager | <p>a. To select a column for a distribution key, select the corresponding check box in the DISTRIBUTION KEY column.</p> <p>You can use a filter to find particular columns:</p> <p>Click  to display the search field. Type the names of columns you are looking for in the search field, either fully or partially. This will display just the column names that contain your search string.</p> <p>Selected columns appear in a small list or table on the lower left. You can remove a selected column from this list by clearing the check box in the DISTRIBUTION KEY column.</p> <p>Selecting an entry in the small list on the lower left and using the Move Up and Move Down buttons, you can change the order of the columns in the key. The order of the columns in the list has an influence on the hash value that is calculated to determine the target processing node. To place the rows of joined tables on the same processing node, the distribution keys of all tables must yield the same hash value. It is therefore important to specify the distribution key columns for all tables in the same order.</p> <p>b. Repeat the previous step to add further columns to the key. A maximum of four columns is allowed.</p> |
|-------------------------|---|

Remember: It is a best practice to use as few columns as possible in a distribution key.

5. To specify organizing keys:

| | |
|--------------------------------------|--|
| IBM Db2 Analytics Accelerator Studio | <p>a. Select a column to be used as an organizing key in the list on the left and click the right-arrow button next to the list box at the bottom.</p> <p>The Name like filter field makes it easier to find particular columns if the list is long. Type a column name in this field, either fully or partially, to display just the columns bearing or starting with that name. The names of columns that are currently selected as keys are grayed out.</p> <p>Selected columns appear in the lower list box on the right. You can remove a selected column by first selecting it in this box, and then clicking the left-arrow button.</p> <p>b. Repeat the previous step to add further keys. A maximum of four keys is allowed.</p> |
|--------------------------------------|--|

| | |
|-------------------------|--|
| IBM Data Server Manager | <p>a. To select a column as an organizing key, select the corresponding check box in the ORGANIZATION KEY column.</p> <p>You can use a filter to find particular columns:</p> <p>Click  to display the search field. Type the names of columns you are looking for in the search field, either fully or partially. This will display just the column names that contain your search string.</p> <p>You can remove an organizing key by clearing the check box in the ORGANIZATION KEY column.</p> <p>b. Repeat the previous step to add further keys. A maximum of four keys is allowed.</p> |
|-------------------------|--|

6. Click **OK**.

Related concepts

Choosing a distribution key

By default, all rows in accelerator-shadow tables are evenly distributed among the existing worker nodes (random distribution). When a query includes table joins, it can be that a join can only be executed if table rows are sent from one worker node to another (redistribution), or that all rows are first sent to the Netezza host to be distributed to the worker nodes from there (broadcast). Both, redistribution and broadcast, can be very time-consuming when big tables with millions or even billions of records are involved, to the extent that the accelerator becomes ineffective.

Choosing an organizing key

Organizing keys can speed up accelerated queries even further as they diminish the time that is needed to scan the disks belonging to a single worker node.

Related information

[IBM DB2 Analytics Accelerator for z/OS: Stored Procedures Reference](#)

Synchronizing schemas (IBM Db2 Analytics Accelerator Studio only)

When columns have been added to a Db2 for z/OS table and a corresponding accelerator-shadow table exists, the schemas of both tables differ because the accelerator-shadow table does not yet include the new columns. The synchronization function adds the missing columns to the schema of the accelerator-shadow table, so that the schemas of both tables are in sync.

About this task

The only supported schema change is an add-column operation (ALTER TABLE ADD COLUMN). Although it is detected and affected accelerator-shadow tables are flagged with a *synchronization needed* icon in the **Tables** section of the **Accelerator** view, the dropping of a column from an original Db2 for z/OS table cannot be handled by the synchronization function. If you try to synchronize such a table, you receive an error message saying that the synchronization cannot be carried out. This means that in this and all other unsupported cases, you must:

1. Remove the table from the accelerator.
2. Redefine the table.
3. Reload the table.

Already running queries against an accelerator-shadow table with a pending schema change are completed. New queries against the table are blocked.

If you run the stored procedure on a set of different tables and an error or warning occurs, the affected tables are skipped and processing continues (no rollback).

If a column was added to a table that is enabled for incremental updates, you must, under normal conditions, remove the table from the accelerator, redefine it, reload it, and finally re-enable incremental updates. You can configure IBM InfoSphere Change Data Capture for z/OS to handle such events without you having to complete these steps, but this feature brings an additional degree of complexity to the process, and should therefore only be used if the time needed for a reload, during which the table is unavailable, is intolerably long. For more information, see the description of the SYSPROC.ACCEL_SYNCHRONIZE_SCHEMA stored procedure in the *IBM Db2 Analytics Accelerator for z/OS: Stored Procedures Reference*.

It is possible to synchronize the schema of a table or partition that was archived with the High Performance Storage Saver. That is, columns are added to the archived table, either with their current values, or, when empty, with the default values defined for these columns.

However, bear in mind that the image copy taken at archiving time contains a different table schema (with fewer columns). The image copy thus restores an older state of the table or partition. The added columns not included in the image copy will be present, but filled with the default values defined for these columns.

If more than one accelerator is used for high availability and workload balancing, you must run synchronize the schema on each accelerator with a copy of the affected table. Repeat this after each schema change.

If *federated access* has been set up for a table with added columns, you must remove and then re-create the reference tables because these tables no longer reflect the actual state of the referenced accelerator-shadow table.

The following restrictions exist:

- Some restrictions exist for the column default values that are allowed. In general, these must be explicit rather than uncertain. For example, a table cannot be synchronized if a hexadecimal string was used to define a column's default value.
- A table or partition archived by the High Performance Storage Saver allows a maximum of 255 schema changes. If this number is exceeded, SQL code -4732 is returned. To recover from a situation like this, you must:
 1. Restore the archived table or partition.
 2. Remove the image copy by running the MODIFY utility.
 3. Re-archive the table or partition.
- It is not possible to modify the schema of (add columns to) accelerator-only tables. So if you use in-database transformation or IBM Netezza Analytics, you must re-create the underlying tables.

To detect diverging table schemas, the SYSPROC.ACCEL_GET_TABLES_INFO stored procedure is run on your data server. The synchronization itself is carried out by the SYSPROC.ACCEL_SYNCHRONIZE_SCHEMA stored procedure. For information about the privileges that are required to run these procedures and further details, see the appropriate sections in the *IBM Db2 Analytics Accelerator for z/OS: Stored Procedures Reference*. A link to this document is provided under **Related reference** at the end of this topic.

Restriction: Currently, you can execute the following steps from IBM Db2 Analytics Accelerator Studio only because there is no functional equivalent in IBM Data Server Manager.

Procedure

1. When you open the **Accelerator** view of an accelerator with tables whose schemas differ from the schemas of the original tables in Db2, the **Synchronize Schema** window comes up automatically, and you can select tables with added columns for synchronization. See step [“7” on page 126](#) and continue from there.
2. To synchronize the schemas at a later time, reopen the **Accelerator** view in question.

3. Navigate to the **Tables** section.
4. A schema change is indicated by a modified icon for schemas and tables (a white cross in a red circle is added). The icon shows up next to the schema name and the names of tables affected by the change.
See the following screen capture:

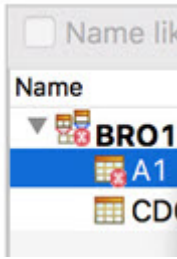

5. Move the mouse pointer over the icon.
A message box with details about the schema change opens:

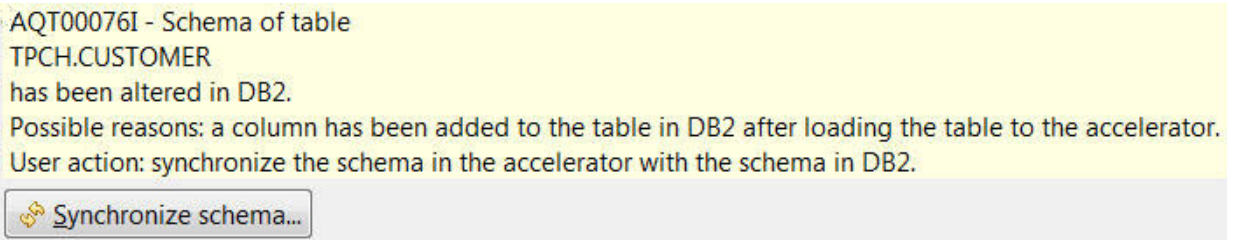

6. Click **Synchronize schema** in the message box.
7. The **Synchronize Schema** window lists all tables on the accelerator that have not yet been synchronized. Select those that you want to process.
The window provides buttons to speed up the process if you have to select many tables: Click **Select All** to select all tables in the window or **Deselect All** to clear all selected check boxes in front of table names.
8. Click **OK**.

Related information

[IBM DB2 Analytics Accelerator for z/OS: Stored Procedures Reference](#)

Running an SQL script from your administration client

To modify connected databases or create objects in these databases, you can run SQL scripts directly from your administration client. This is useful because you need not change the system or console to execute SQL statements.

Before you begin

Make sure that the user running the administration client has sufficient privileges on the selected databases to execute the SQL code.

About this task

If you run an accelerated query from the SQL Script Editor of IBM Data Studio, the SQL Script Editor invokes the JDBC method `Statement.setNumRows()`, which causes the JDBC driver to convert the query into a read-only query (FOR READ ONLY). This happens even if the FOR READ ONLY clause is not part of the query statement. If the clause is not part of the statement, the query might end with an error message and reason code 4 (The query is not read-only). The error occurs with actual queries in a production environment and EXPLAIN-only queries alike. With EXPLAIN-only queries, the error does not matter. Actual queries, however, will not return results when the error occurs. Therefore, add the FOR READ ONLY clause explicitly to the SQL statement text if you submit actual queries from the SQL Script Editor.

Procedure

1. From your administration client, connect to the Db2 subsystem or data sharing group the query is supposed to run against:

| | |
|--------------------------------------|---|
| IBM Db2 Analytics Accelerator Studio | In the Administration Explorer , double-click a database connection profile. |
| IBM Data Server Manager | Select the appropriate connection from the drop-down list on the top banner. |

2. Open the SQL editor:

| | |
|--------------------------------------|---|
| IBM Db2 Analytics Accelerator Studio | <ol style="list-style-type: none"> a. On the toolbar of the Administration Explorer, click the downward-pointing arrow next to the New button. b. Select New SQL Script from the menu. |
| IBM Data Server Manager | <ol style="list-style-type: none"> a. Click  in the upper left. b. Select RUN SQL. <p>Note: This option is available only if an active database connection has been selected from the drop-down list on the top banner.</p> |

3. Type or paste your SQL statement in the text area:

| | |
|--------------------------------------|--|
| IBM Db2 Analytics Accelerator Studio | <p>Type or paste the SQL statement in the blank space of the Script<x>.sql workspace that opens on the upper right.</p> <p>Note: <x> stands for a counting number (integer). This means that your first SQL script is named Script1.sql, the second Script2.sql, and so on.</p> |
| IBM Data Server Manager | Type or paste the SQL statement in the text area that opens in the upper half of the window. |

4. Run your SQL script:

| | |
|--------------------------------------|---|
| IBM Db2 Analytics Accelerator Studio | <ol style="list-style-type: none"> a. Click  <p>If no connection profile is selected in the Administration Explorer, the Select Connection Profile window comes up. If so, select the proper database connection profile (database server) in the Connections list.</p> <ol style="list-style-type: none"> b. Click Finish. |
| IBM Data Server Manager | Select Run > Run all from the toolbar. |

What to do next

You might want to save your SQL script for reuse:

| | |
|--------------------------------------|--|
| IBM Db2 Analytics Accelerator Studio | SQL scripts can be saved in your local workspace if you created an appropriate project before, |
|--------------------------------------|--|

| | |
|-------------------------|---|
| | for example a <i>Data Development</i> project. For information on how to create and work with Data Development projects, refer to <i>Creating a data development project</i> in the online help of IBM Data Studio. |
| IBM Data Server Manager | <p>You can save your SQL script using one of the options on the Script menu on the toolbar:</p> <p>Save Saves your script to the computer where IBM Data Server Manager is installed. You can view all scripts saved on this computer if you click the Saved scripts tab in the lower half of the Run SQL window.</p> <p>Save to client Saves the script to your local workstation, that is, the computer that you are currently using to work with IBM Data Server Manager.</p> |

Running IBM Netezza Analytics stored procedures

You can now run a number of IBM Netezza Analytics stored procedures on an accelerator to speed up data preparation and the creation of models for data analytics. In addition, there is a support package for the R programming language (called `ibmdbR`), which allows you to start these stored procedures from R scripts.

The following IBM Netezza Analytics stored procedures are currently supported:

- `arule`, `predict_arule`
- `dectree`, `grow_dectree`, `prune_dectree`, `predict_dectree`
- `divcluster`, `predict_divcluster`
- `export_model_to_table`

Important: This stored procedure is needed for the support of the R programming language.

- `glm`, `predict_glm`, `print_glm`

Restriction: You can use the `glm` stored procedure on Unicode data only.

- `impute_data`
- `iqr`
- `kmeans`, `predict_kmeans`
- `linear_regression`, `predict_linear_regression`

Restriction: You can use the `linear_regression` stored procedure on Unicode data only.

- `median`, `median_disc`
- `model_exists`, `drop_model`, `drop_all_models`, `list_models`
- `moments`
- `naivebayes`, `predict_naivebayes`
- `outliers`,
- `pmml_model`
- `quantile`, `quantile_disc`
- `quartile`, `quartile_disc`
- `random_sample`
- `regtree`, `grow_regtree`, `prune_regtree`, `predict_regtree`

- split_data
- std_norm
- twostep, predict_twostep

Installation

For information on how to install and enable these stored procedures, see *Installing the IBM Netezza Analytics stored procedure package* in the *Installation Guide*. This chapter also contains information on how to obtain the R support package (ibmdbR).

EXPLAIN information

After creating the necessary EXPLAIN tables, you can analyze queries by invoking the Db2 EXPLAIN function. Such queries are accepted by regular and virtual accelerators alike. The analysis shows whether a query can be accelerated, indicates the reason for a failure, and gives a response time estimate. The outcome of the analysis can also be visualized in an access plan graph.

Note: Unlike regular accelerators, virtual accelerators can process EXPLAIN queries only. That is, the SQL queries sent to a virtual accelerator must contain an EXPLAIN statement. Otherwise the query is rejected.

Preparations

To be able to use the EXPLAIN function in order to check whether a query can be accelerated, you need the following EXPLAIN tables:

- PLAN_TABLE
- DSN_QUERYINFO_TABLE

For basic EXPLAIN information, you need just the PLAN_TABLE. To create EXPLAIN tables (including DSN_QUERYINFO_TABLE) for a specific user, customize and run the DSNTESC member of the SDSNSAMP library. Modify and run the DSNTIJOS sample job to create EXPLAIN tables that are qualified by SYSIBM and Db2OSC, as these tables are used by Db2 optimization tools like IBM Query Tuner.

Description

The EXPLAIN tables provide the following information:

PLAN_TABLE

For each accelerated query, the query blocks are pruned and a single row is inserted in the PLAN_TABLE with an ACESSTYPE of 'A'. The query is thus represented by a single row with the value 1 in the QBLOCKNO column. For queries that are not accelerated, the PLAN_TABLE can contain multiple rows representing the tables accessed by each query block, with an ACESSTYPE other than 'A'. If there are multiple rows belonging to the same query, these are numbered consecutively in the QBLOCKNO column.

DSN_QUERYINFO_TABLE

Additional EXPLAIN information can be found in the DSN_QUERYINFO_TABLE. See [Table 36 on page 129](#).

| Table 36. Important columns in DSN_QUERYINFO_TABLE | |
|--|---|
| Column | Description |
| QINAME1 | When the ACESSTYPE of a query in the PLAN_TABLE is A, and the REASON_CODE in DSN_QUERYINFO_TABLE is 0, this row contains the name of the accelerator that will process the query. |

| <i>Table 36. Important columns in DSN_QUERYINFO_TABLE (continued)</i> | |
|---|--|
| Column | Description |
| QINAME2 | When the ACCESTYPE of a query in the PLAN_TABLE is A, and the REASON_CODE in DSN_QUERYINFO_TABLE is 0, this row contains the location name of the accelerator that will process the query. The location name is the unique name of the accelerator in the SYSIBM.LOCATIONS table. Mostly, this is the same name as the accelerator name. |
| TYPE | The type of the output for this row. A type of A means that Db2 for z/OS routes the query to an accelerator. |
| REASON_CODE | The reason code for a query. When the value of TYPE is A and the reason code is 0, the query can be accelerated. If the REASON_CODE column contains a value other than 0, something prevents the acceleration of the query. To look up the other reason codes, refer to Table 37 on page 130 . |
| QI_DATA | When the value of TYPE is A and the reason code is 0, this row contains the SQL code of the converted query that was routed to the accelerator. If a query has a reason code other than 0, this column contains a description of the reason code. |

Reason codes

[Table 37 on page 130](#) lists and describes the various reason codes. A reason code greater than 0 indicates that a query cannot be accelerated.

| <i>Table 37. Possible reason codes in DSN_QUERYINFO_TABLE</i> | | |
|---|---|---|
| REASON_CODE | Description | Suggested solution |
| 0 | The query qualifies for routing to an accelerator. | N/A |
| 1 | An active accelerator or tables enabled for query acceleration could not be found when the statement was executed. If an accelerator is available, make sure that it is started, and that enabled tables exist on that accelerator. | Start the accelerator. |
| 2 | The query could not be routed to an accelerator because the CURRENT QUERY ACCELERATION special register is set to the value NONE. | Set the CURRENT QUERY ACCELERATION special register to one of the following values: <ul style="list-style-type: none"> • ALL • ELIGIBLE • ENABLE • ENABLE WITH FAILBACK |
| 3 | The query is a short-running Db2 query or query acceleration is not advantageous. | If you must accelerate the query for some reason, set the CURRENT QUERY ACCELERATION special register to one of the following values: <ul style="list-style-type: none"> • ALL • ELIGIBLE |
| 4 | The query is not read-only. | Ensure that the query meets the criteria for a read-only query. |

Table 37. Possible reason codes in DSN_QUERYINFO_TABLE (continued)

| REASON_CODE | Description | Suggested solution |
|-------------|--|--|
| 6 | The query uses a scrollable cursor or a remotely defined rowset-positioned cursor. | Remove the SCROLL clause or WITH ROWSET POSITIONING clause from the cursor declaration. |
| 7 | The query uses multiple encoding schemes. | Ensure that all objects to which the query refers have the same encoding scheme. |
| 8 | The FROM clause of the query specifies a data-change-table-reference. | Rewrite the FROM clause of the query so that it does not include a data-change-table-reference clause. |
| 9 | The query contains a nested table expression. | Ensure that the FROM clause of the query does not contain a subquery. |
| 10 | The query contains a recursive reference to a common table expression. | Ensure that the FROM clause of the query does not reference a common table expression. |
| 11 | The query contains an unsupported expression. The QI_DATA column contains this expression. | Remove the unsupported expression from the query. |
| 12 | The query references a table with one of the following characteristics: <ul style="list-style-type: none"> • The table is not defined on the accelerator. • The table is defined on a different accelerator. • The table is not enabled for query acceleration. | Ensure that all tables that are referenced by the query are defined on the same accelerator, and that all tables are enabled for query acceleration. |
| 13 | The accelerator server that contains the tables that are referenced in the query is not started. | Start the accelerator that contains the tables that are referenced in the query. |
| 14 | A column that is referenced in the query has been altered after loading the column data into the corresponding accelerator-shadow table. | Reload the accelerator-shadow table. |
| 15 | The query uses functionality that is available only in Db2 10 for z/OS new-function mode or later. | Ensure that the query does not use any functionality that is available in Db2 10 for z/OS new-function mode or later. |
| 16 | The query is not in a package. | Bind the application that contains the query into a package. |
| 17 | The query is an INSERT from SELECT statement. Subsystem parameter QUERY_ACCEL_OPTIONS does not specify option 2 to enable the acceleration of INSERT from SELECT statements. | Enable the acceleration of INSERT from SELECT statements by updating subsystem parameter QUERY_ACCEL_OPTIONS to include option 2. |
| 18 | The query uses new Db2 11 for z/OS functionality. | Try to rewrite the query so that it does not use the new (unsupported) Db2 11 for z/OS functionality. |

Table 37. Possible reason codes in DSN_QUERYINFO_TABLE (continued)

| REASON_CODE | Description | Suggested solution |
|-------------|---|--|
| 19 | The accelerator is not at the correct level (that is, you are using an older version) and therefore does not support all the functions in the SQL statement. The QI_DATA column in DSN_QUERYINFO_TABLE contains the function text or expression text that has caused the failure. Update the accelerator software to enable query acceleration for the SQL statement that contains the function text or expression text. | Update the accelerator software to a service level that supports all functions in the query. |
| 21 | The query contains an unsupported correlated subquery. | If possible, rewrite the query without using the unsupported subquery. |
| 22 | <p>The statement references an accelerator-only table, but cannot be routed to an accelerator. For example:</p> <ul style="list-style-type: none"> A MERGE statement references an accelerator-only table. An UPDATE or DELETE statement references an accelerator-only table, but the target table of the UPDATE or DELETE is a normal Db2 table, for example: <pre>UPDATE db2_table SET ... (SELECT ... FROM accelerator_only_table)</pre> <ul style="list-style-type: none"> An INSERT, UPDATE, or DELETE refers to a row expression with a sub-select, for example: <pre>UPDATE accelerator_only_table SET (C1,C2) = (SELECT C3,C4 FROM table_2)</pre> | <ul style="list-style-type: none"> Remove the reference to the accelerator-only table If possible, rewrite the statement so that it references a regular Db2 table instead of an accelerator-only table. |
| 24 | The DDL or DML statement cannot be offloaded because the connection to the accelerator server does not allow updates. This can occur when a two-phase commit requester (for example, a Db2 for z/OS requester) connects to a Db2 for z/OS server to offload a DDL or DML statement." | Issue the DDL or DML statement directly from the Db2 for z/OS server, or from a requester which does not require a two-phase commit, for example, the IBM Data Server Driver for JDBC. |

For example, reason code 7 resolves to The query uses multiple encoding schemes. If you receive this reason code, check the encoding schemes that are used by the tables. If different schemes are used, you might have to curtail the query so that it only refers to columns that use the same coded character set identifier (CCSID) or code page.

Sample EXPLAIN query

```
-- clean up explain tables
DELETE FROM PLAN_TABLE WHERE QUERYNO = 3825;
```

```

DELETE FROM DSN_QUERYINFO_TABLE WHERE QUERYNO = 3825;

-- enable accelerator for this session
SET CURRENT QUERY ACCELERATION=ENABLE;

-- explain query
EXPLAIN ALL SET QUERYNO = 3825 FOR
SELECT SUM(L_QUANTITY), SUM(O_TOTALPRICE), O_CUSTKEY
FROM TPCH.LINEITEM L JOIN TPCH.ORDERS O ON L.L_ORDERKEY = O.O_ORDERKEY
WHERE O.O_ORDERDATE > '01.01.1994' GROUP BY O.O_CUSTKEY;

-- check if query is eligible for acceleration
SELECT QBLOCKNO, ACESSTYPE FROM PLAN_TABLE AS P WHERE QUERYNO = 3825;

SELECT QINAME1 AS ACCELERATOR, REASON_CODE, QI_DATA FROM DSN_QUERYINFO_TABLE
WHERE QUERYNO = 3825;

```

The DELETE statements at the beginning remove old information from the EXPLAIN tables.

The SET CURRENT QUERY ACCELERATION=ENABLE special register is required, even for virtual accelerators. Leaving it out would mean to run an in-house Db2 query that is not sent to any accelerator.

Then comes the actual test query. It starts with the mandatory EXPLAIN statement. A number is assigned to the query so that the EXPLAIN information pertaining to that query can be easily extracted from the EXPLAIN tables by means of a SELECT statement.

The first SELECT statement extracts the QBLOCKNO and the ACESSTYPE column values of the query from the PLAN_TABLE. The second SELECT statement extracts the QINAME1, REASON_CODE, and QI_DATA values of the query from DSN_QUERYINFO_TABLE.

Related tasks

[Displaying an access plan graph](#)

An access plan graph is a visual representation of a query that shows the database objects that are accessed by the query and the order in which this is done.

Displaying an access plan graph

An access plan graph is a visual representation of a query that shows the database objects that are accessed by the query and the order in which this is done.

About this task

An access plan graph can give you valuable information. Looking at an access plan graph of a query, you can verify whether your query really uses a specific table on the accelerator. For example, you can define accelerator-shadow tables and then revisit the access plan graph of the query to check whether the query used these tables. In addition, an access plan graph can show which tables are referenced indirectly by the query if the query references a view. You can thus identify all accelerator-shadow tables that you need to load before you can accelerate the query.

Access plan graphs are derived from information in Db2 EXPLAIN tables. To obtain the EXPLAIN data (query result) and convert it to the XML format for output, IBM Db2 Analytics Accelerator Studio runs the **SYSPROC.ACCEL_GET_QUERY_EXPLAIN** stored procedure on your data server. For information about the privileges that are required to run this procedure and further details, see the appropriate section in the *IBM Db2 Analytics Accelerator for z/OS: Stored Procedures Reference*. A link to this document is provided under **Related reference** at the end of this section.

Restriction: A function to display access plan graphs is currently not available in IBM Data Server Manager.

Procedure

1. In the **Administration Explorer**, right-click the icon of the Db2 subsystem that contains the source tables for the query.
2. Select **New SQL Script** from the menu.

- The **Script.sql** window that opens on the upper right contains a blank pane. In this pane, type or paste the query that you want to display an access plan graph for.
- Click the  icon.
- On the **General Settings** page of the **Collect Explain Data** wizard, click **Next**.
- From the **QUERY ACCELERATION** drop-down list, select **ENABLE, ALL**, or **ELIGIBLE**.
- If you use the High Performance Storage Saver, also select a suitable value from the **GET_ACCEL_ARCHIVE** drop-down list.
In selecting the value **Yes**, you include data in the query that was archived by the High Performance Storage Saver. In selecting **No**, you exclude this type of data.
- Click **Finish**.

Results

You see the access plan graph at the bottom of the window.

Related concepts

EXPLAIN information

After creating the necessary EXPLAIN tables, you can analyze queries by invoking the Db2 EXPLAIN function. Such queries are accepted by regular and virtual accelerators alike. The analysis shows whether a query can be accelerated, indicates the reason for a failure, and gives a response time estimate. The outcome of the analysis can also be visualized in an access plan graph.

Related reference

Types of access plan graphs and nodes in these graphs

Different graphs are displayed for queries that can be accelerated and queries that cannot be accelerated. Read a brief article on how these graphs differ, and which set of nodes you can expect in either of these.

Related information

[IBM DB2 Analytics Accelerator for z/OS: Stored Procedures Reference](#)

Types of access plan graphs and nodes in these graphs

Different graphs are displayed for queries that can be accelerated and queries that cannot be accelerated. Read a brief article on how these graphs differ, and which set of nodes you can expect in either of these.

Restriction: A function to display access plan graphs is currently not available in IBM Data Server Manager.

If a query cannot be accelerated and is processed by Db2 for z/OS, you see the regular Db2 for z/OS access plan. Unless the query is an EXPLAIN-ONLY query (queries sent to virtual accelerators invariably belong to this category), you see an additional node labeled **NOT ACCEL..** This node contains the reason code, which explains why the query could not be accelerated.

Example

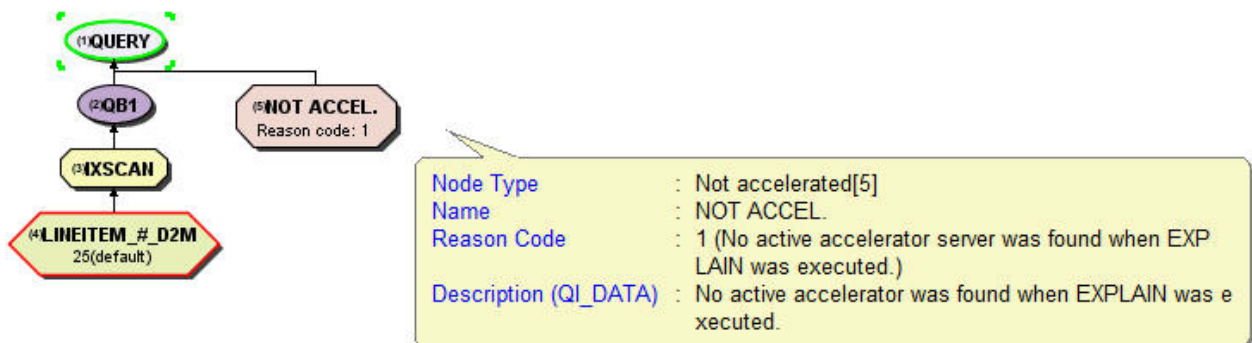

For an overview of the nodes that might occur in a Db2 for z/OS access plan graph, follow the **Related information** link at the end of this topic.

If a query can be accelerated, you see the access plan as it will be executed on the accelerator. The nodes that can occur in this type of graph are briefly described in [Table 38 on page 135](#). The nodes reflect the different stages during query processing. Some of these give you valuable information for query optimization.

| <i>Table 38. Nodes in access plan graphs</i> | | |
|--|--|--|
| Node | Additional information | Description |
| ACCELERATED | | Indicates that a query could be accelerated. This node is not shown in graphs for EXPLAIN only queries, but only in graphs for real queries. That is, the query must have been routed to an accelerator by setting the SET CURRENT QUERY ACCELERATION special register to one of the following values: <ul style="list-style-type: none"> • ENABLE • ENABLE WITH FAILBACK • ELIGIBLE • ALL |
| AGGR | First number Number of affected rows Second number Total size of the affected rows | Aggregation. Indicates that data will be aggregated to calculate the results of statements, such as SUM, AVG, MAX, or COUNT. The numbers indicate the number of aggregated rows and the size of these rows. |
| BROADCAST | First number Number of broadcast table rows Second number Total size of the broadcast rows | Broadcast of table rows. This means that all rows relevant for a join must be sent over the network to the active coordinator node (Netezza host) to be redistributed from there. When large tables with more than 100 million rows are involved, broadcasts have a highly negative impact on the performance. Avoid broadcasts by using distribution keys. |
| GRPBY | First number Number of grouped rows Second number Total size of the grouped rows | Group by. Indicates that resulting rows are grouped according to a GROUP BY clause in the query. |
| HSJOIN | First number Number of surviving rows after the join Second number Total size of the surviving rows | Hash join. A way of executing a table join that employs hashing. It is the most efficient way of executing equality joins. When a large amount of data needs to be processed, hashing achieves its optimum performance when it is combined with a colocated join (in most cases, this means use of a distribution key). The row and size numbers refer to the surviving rows after the join. |

Table 38. Nodes in access plan graphs (continued)

| Node | Additional information | Description |
|------------|--|---|
| NOT ACCEL. | The node contains the reason code for the failure. | <p>Indicates that a query cannot be accelerated. This node is not shown in graphs for EXPLAIN only queries, but only in graphs for real queries. That is, the query must have been routed to an accelerator by setting the SET CURRENT QUERY ACCELERATION special register to one of the following values:</p> <ul style="list-style-type: none"> • ENABLE • ENABLE WITH FAILBACK • ELIGIBLE • ALL |
| NLJOIN | <p>First number Number of surviving rows after the join</p> <p>Second number Total size of the surviving rows</p> | <p>Nested loop join (called expression-join in Netezza terminology). A way of executing joins that is chosen for non-equality joins, that is, joins such as WHERE (T1.COL1 - T2.COLx > 0). It is also used for queries that use EXISTS clauses. In a nested loop join, each row in the first table is matched against each row in the second, and the join predicate is evaluated for each of the pairs. It is thus a slow way of executing a join. If the performance is poor, see if you can change the non-equality join into an equality join.</p> |
| QUERY | <p>First number Number of rows that are returned to Db2</p> <p>Second number Total size of the rows that are returned to Db2</p> | <p>Indicates the point at which the active coordinator node (Netezza host) returns the query results to Db2 for z/OS. The numbers indicate the number of rows in the result set and the size of these rows.</p> |
| REDIST | The column name indicates the join column that causes the redistribution. | <p>Redistribution of table rows. That is, to execute a join, table rows must be sent over the network from one worker node to another. When large accelerator-shadow tables with more than 100 million rows are involved, redistributions have a negative impact on the performance and should be avoided. Consider the use of a distribution key to achieve a colocated join.</p> |
| RETURN | <p>First number Number of returned rows</p> <p>Second number Total size of the returned rows</p> | <p>Return of results from the worker nodes to the active coordinator node (Netezza host).</p> |
| SORT | <p>First number Number of sorted rows</p> <p>Second number Total size of the sorted rows</p> | <p>Sorting of rows. The numbers indicate the time needed to do the sorting, the number of rows sorted, and the size of these rows.</p> |

Table 38. Nodes in access plan graphs (continued)

| Node | Additional information | Description |
|-------------|---|---|
| SUBSELECT | | Subselect. That is, the query contains at least one outer query and one inner query, in which the inner query refers to a subset of the table rows captured by the outer query. The SUBSELECT node reflects the evaluation of the nested SELECT statements. |
| <TABLENAME> | <p>First number Number of table rows</p> <p>Second number Total size of the table rows</p> <p>Important: A <TABLENAME> node always shows the current number of table rows and the current size of the rows. These are not necessarily the figures that were valid at the time the query was run.</p> | The name of a base table used in the query. |
| TBSCAN | <p>First number Number of “surviving” rows, that is, rows that have not been filtered out due to unused columns, restrictive clauses, or organizing keys.</p> <p>Second number Total size of the surviving rows</p> | Table scan. This node represents the scan of an accelerator-shadow table during query processing. |
| UNIONA | <p>First number Number of rows in the unified result set</p> <p>Second number Total size of the rows in the unified result set</p> | Union. Indicates a union of two result sets. This node occurs if the query contains a UNION ALL or UNION DISTINCT statement. |
| UNIQUE | <p>First number Number of surviving rows after the elimination</p> <p>Second number Total size of the surviving rows</p> | Elimination of duplicate table rows. |

Related concepts

EXPLAIN information

After creating the necessary EXPLAIN tables, you can analyze queries by invoking the Db2 EXPLAIN function. Such queries are accepted by regular and virtual accelerators alike. The analysis shows whether a query can be accelerated, indicates the reason for a failure, and gives a response time estimate. The outcome of the analysis can also be visualized in an access plan graph.

Selecting and ordering query monitoring columns

You can customize the view that displays the query history of an accelerator. That is, you can select the columns to be displayed. In IBM Db2 Analytics Accelerator Studio, you can also change the order of their appearance.

Procedure

1. Open the list of accelerators:

| | |
|--------------------------------------|--|
| IBM Db2 Analytics Accelerator Studio | In the Administration Explorer , go to the Accelerators folder. |
| IBM Data Server Manager | <ol style="list-style-type: none"> a. Click  in the upper left. b. Select ADMINISTER > Accelerators. |



2. Go to the view or page that lists the query history:

| | |
|--------------------------------------|--|
| IBM Db2 Analytics Accelerator Studio | <ol style="list-style-type: none"> a. Scroll down until you see the heading Query Monitoring. b. Click the twistie next to the heading to reveal the contents of the section. |
| IBM Data Server Manager | <ol style="list-style-type: none"> a. Select the accelerator in the list. b. Click the Manage button on the toolbar. c. Click the Queries tab. |

You see the recent query history (SQL statements and other information about recent queries). You can select various information columns, some of which are displayed by default. For a list of the available columns, click the appropriate **Related reference** link at the end of this topic.



Important: The reference for all times that are displayed is the accelerator system time. The accelerator system time is determined by the first Db2 subsystem that was added to the configuration. A warning is issued if the accelerator works with data from a Db2 subsystem that was not the first to be added. It is very important to keep this in mind if the Db2 subsystems (data servers) are situated in different time zones.

3. Access the column display function:



| | |
|--------------------------------------|---|
| IBM Db2 Analytics Accelerator Studio | Click  . |
| IBM Data Server Manager | Click  on the toolbar. |

4. To add columns:



| | |
|--------------------------------------|--|
| IBM Db2 Analytics Accelerator Studio | <p>In the Adjust Query Monitoring Table window, you see the following lists:</p> <p>Available columns The names of available columns that are currently not selected for display</p> <p>Shown columns The names of the columns that are currently displayed. The order from top to bottom indicates their appearance in the Accelerator view from left to right.</p> |
|--------------------------------------|--|

| | |
|-------------------------|--|
| | <ul style="list-style-type: none"> To add a single column for display in the Accelerator view, select it in the Available columns list and click  to move the column to the Shown columns list. To move all available columns to the Shown columns list, click . Click OK when finished. |
| IBM Data Server Manager | <ol style="list-style-type: none"> Select the appropriate check boxes in front of the column names in the drop-down list. Click OK. |

5. To remove columns from the display:

| | |
|--------------------------------------|--|
| IBM Db2 Analytics Accelerator Studio | <ul style="list-style-type: none"> To hide a single column from the display in the Accelerator view, select it in the Shown columns list and click  to move the column to the Available columns list. To remove all columns from the display, click . Click OK when finished. |
| IBM Data Server Manager | <ol style="list-style-type: none"> Clear the appropriate check boxes in front of the column names in the drop-down list. Click OK. |

6. In IBM Db2 Analytics Accelerator Studio, you can also change the order in which the columns appear:

- To change the order of appearance in the **Accelerator** view, select a column in the **Shown columns** list and click  or  to move the column up or down.
The order of the columns from top to bottom represents the order in which these columns appear from left to right in the **Accelerator** view.
- To restore the default settings for the **Query Monitoring** section in the **Accelerator** view, click **Restore Defaults**.
- Click **OK** when finished.

Results

| | |
|--------------------------------------|---|
| IBM Db2 Analytics Accelerator Studio | Your settings are applied to the table in the Query Monitoring section, that is, columns are added, removed or their order of appearance is changed. |
| IBM Data Server Manager | Your settings are applied to the query history, that is, columns are added or removed from the display. |

What to do next

The **Query Monitoring** section in IBM Db2 Analytics Accelerator Studio offers a few additional functions:

- To show further details about a selected query or to rerun the query, click:

Show SQL

To view the SQL of the query

Show Plan

To view the access plan graph of the query

Note: For accelerator-only tables, the **Show SQL** and **Show Plan** functions show information about data manipulation (DML) jobs, such as INSERT, UPDATE, or DELETE, but not data definition (DDL) jobs, such as CREATE or DROP.



This drop-down button is available for cloud accelerators only. It leads to the following functions:

Show Plan

Same as the button described before

Show Explain Details

Opens a window with a textual representation of a query's access plan and other information about the query execution. As an example, see the following extract:

```
...
FROM
  KLMDWEDB14."CUSTOMER-UID_01140003-V0" AS Q1
WHERE
  (Q1."DWA_Partition_ID (hidden)" <= 100001)
```

Access Plan:

```
-----
Total Cost:          105.849
Query Degree:        8
```

```

      Rows
RETURN
(   1)
  Cost
  I/O
  |
333.333
LTQ
(   2)
105.849
  15
  |
333.333
CTQ
(   3)
105.778
  15
  |
333.333
TBSCAN
(   4)
105.766
  15
  |
  1000
CO-TABLE: KLMDWEDB14
CUSTOMER-UID_01140003-V0
Q1
```

Operator Symbols :

```
-----
Symbol      Description
-----
ATQ        : Asynchrony
```

...

Re-Run Query

To rerun the query

Cancel

To cancel a running query or an INSERT, UPDATE, or DELETE operation on an accelerator-only table.

- To limit the number of queries that are displayed in the **Query Monitoring** table.
 1. Show all recent queries, just the queries that are currently being processed, or just the completed queries, by selecting the appropriate value from the **View** drop-down list:

All Queries

To show all recent queries

Active Queries

To show just the queries that are currently being processed

Query History

To show just the completed queries

2. To limit the displayed queries on the basis of their values in one of the columns of the **Query Monitoring** table:

- a. Change the default (**All**) in the first drop-down list to the right of the **Show** label to one of the restricting values (**Highest 5**, **Highest 10** and so on).
- b. From the other drop-down list further to the right, select the column in the **Query Monitoring** table that the setting in the previous step refers to.
- c. Click **Run**.

This limits the number of displayed queries to those with the highest value in the selected column. If you select a column containing time values, this means that the display will be restricted to the slowest queries. The designers of the product have opted for this order because the slowest queries usually have the highest potential for query optimizing, and are most probably the ones that a database administrator wants to touch again after they have been run.

Related reference

Selectable columns in the query history

The table in this section briefly describes all columns that can be selected for display in the query history of an accelerator.

Related information

[Query history is not displayed - error message returned](#)

The query history is not displayed in the **Accelerator** view and a corresponding error message is returned.

Selectable columns in the query history

The table in this section briefly describes all columns that can be selected for display in the query history of an accelerator.

| Column name | Description | Available in IBM Db2 Analytics Accelerator Studio | Available in IBM Data Server Manager |
|-------------------|---|---|--------------------------------------|
| Accounting String | Accounting information that can be provided by an application programming interface (API) on the client side, such as the setDb2ClientAccountingInformation API of a connecting JDBC client. For more information, see Providing extended client information to the data source with IBM Data Server Driver for JDBC and SQLJ-only methods | X | |

Table 39. Selectable columns (continued)

| Column name | Description | Available in IBM Db2 Analytics Accelerator Studio | Available in IBM Data Server Manager |
|-------------------------|--|---|--------------------------------------|
| Client User ID | <p>The ID of a connecting client user. This ID can be provided by an application programming interface (API) on the client side, such as the <code>setDb2ClientUser</code> API of a connecting JDBC client.</p> <p>For more information, see Providing extended client information to the data source with IBM Data Server Driver for JDBC and SQLJ-only methods</p> | X | |
| Client Workstation Name | <p>The name or ID of a connecting client workstation. This ID can be provided by an application programming interface (API) on the client side, such as the <code>setDb2ClientWorkstation</code> API of a connecting JDBC client.</p> <p>For more information, see Providing extended client information to the data source with IBM Data Server Driver for JDBC and SQLJ-only methods</p> | X | |
| Collection ID | <p>The ID or name that identifies a group of static SQL packages. If a collection ID is displayed, this means that the static SQL package containing the query belongs to that group.</p> | X | |
| Connection Name | <p>The connection name. Possible values are:</p> <ul style="list-style-type: none"> For batch: BATCH For TSO: TSO For QMF: Db2CALL For Db2 utilities: UTILITY For Db2 private protocol: The Db2 subsystem ID For IMS: The IMS ID For CICS®: The CICS ID For DRDA connections from non-Db2 requesters: SERVER <p>For more information, see IFCID 147 - Thread Correlation Data.</p> | X | |

Table 39. Selectable columns (continued)

| Column name | Description | Available in IBM Db2 Analytics Accelerator Studio | Available in IBM Data Server Manager |
|-----------------|---|---|--------------------------------------|
| Connection Type | <p>The type of the Db2 connection. Valid values are:</p> <p>APPLCTN Application directed access</p> <p>BATCH Batch job</p> <p>CICS CICS attach</p> <p>Db2CAF Db2 call attach</p> <p>DLIBATCH DL/I batch</p> <p>IMS IMS thread</p> <p>IMS BMP IMS attach BMP</p> <p>IMS TBMP IMS transaction BMP</p> <p>IMS CTL IMS control region</p> <p>IMS MPP IMS attach MPP</p> <p>SYSTEM System directed access</p> <p>TSO/E TSO/E foreground and background</p> <p>UNKNOWN Unrecognizable connection type</p> <p>UTILITY Db2 utility</p> <p>For more information, see Thread SQL Counts Attributes.</p> | X | |

Table 39. Selectable columns (continued)

| Column name | Description | Available in IBM Db2 Analytics Accelerator Studio | Available in IBM Data Server Manager |
|----------------|--|---|--------------------------------------|
| Correlation ID | <p>The correlation ID value. Possible values are:</p> <p>For BATCH: Job name.</p> <p>For TSO: Logon ID.</p> <p>For IMS/VS: PST#.PSBNAME</p> <p>For CICS: CONNECTION_TYPE.THREAD_TYPE.THREAD_#.TRAN-ID</p> <p>For RRSAF: CORRELATION-ID value from SIGNON function.</p> <p>For threads using the Db2 private protocol or DRDA from a Db2 requester: This field contains the correlation-ID name of the thread at the requesting location.</p> <p>For threads using DRDA from a non-Db2 requester: This field contains the first 12 characters in the DDM external name (EXTNAM) parameter of the DDM EXCSAT command received as part of the SQL connect.</p> <p>For more information, see IFCID 147 - Thread Correlation Data</p> | X | |
| CPU Time | <p>The overall CPU time that was needed by an accelerator to process a query or data manipulation (DML) statement. This value reflects parallel processing such that the CPU value might exceed the accumulated elapsed time. This is an indicator for the amount of used resources.</p> <p>For completed statements, this is the CPU time from the initial request to the last row being returned to Db2. In case of DML statements, this is measured until the final result (SQLCA) is sent to Db2.</p> <p>For in-process statements, this is the time from the initial request to the current point in time. The counter includes the CPU time that was used by the product and also the CPU time spent in the Netezza system (on the coordinator node and all worker nodes). Because parallel processing is the standard, the CPU time cannot be related to the elapsed time. If query processing has already finished in the Netezza system, the CPU time spent inside this system is included. If the SQL statement is still running in the Netezza system, only the CPU time that was used by IBM Db2 Analytics Accelerator is available.</p> | X | |

Table 39. Selectable columns (continued)

| Column name | Description | Available in IBM Db2 Analytics Accelerator Studio | Available in IBM Data Server Manager |
|--------------------------|--|---|--------------------------------------|
| Data Sharing Group Name | The name of the Db2 data sharing group (if the accelerator is connected to such a group rather than a Db2 subsystem) | X | |
| Data Sharing Member Name | If the accelerator is connected to a Db2 data sharing group, the name of the group member that sent the query. | X | |
| Db2 Subsystem ID | The Db2 subsystem ID. | X | |

Table 39. Selectable columns (continued)

| Column name | Description | Available in IBM Db2 Analytics Accelerator Studio | Available in IBM Data Server Manager |
|--------------|---|---|--------------------------------------|
| Elapsed Time | <p>The total time that was needed to process a query (from the state QUEUED to FAILED, SUCCESSFUL, or CANCELED).</p> <p>The following diagram shows the beginning, duration, and the end of each time in the Query Monitoring section on a time scale. This way, you can better relate the values to each other. It starts with the Start Time (point in time, where the diagram starts and when the accelerator receives the query). The following interval, the Wait Time overlaps with the Execution Time because the Execution Time includes the period that a query stays in the Netezza execution queue. The Execution Time overlaps with the following interval, the Fetch Time, because Db2 starts fetching results when the first result rows have been returned by Netezza, that is, at a time when the entire query has not necessarily finished processing. Finally, the diagram shows the Elapsed Time, which includes all intervals mentioned before because it lasts from the beginning of the Start Time to the time when the query controller stops processing the query.</p>  <p><i>Figure 13. Wait time, execution time, fetch time, and elapsed time in comparison</i></p> | X | X |

Table 39. Selectable columns (continued)

| Column name | Description | Available in IBM Db2 Analytics Accelerator Studio | Available in IBM Data Server Manager |
|-------------------|--|---|--------------------------------------|
| Error Description | The error description or error token that is returned with the SQL Code . The description might be truncated. | X | |
| Execution Time | The time that a query spent in the queue before it was sent to the accelerator plus the time needed to process the query on the IBM PureData System for Analytics. | X | X |
| Fetch Time | The time interval starting with the first retrieval of a result row by Db2 and ending with the last. In most cases, Netezza query execution has already finished when the result retrieval process is still ongoing. | X | X |
| Location Name | Location name of the Db2 subsystem sending the query. | X | |
| LU Name | Network LU (logical unit) name of the requester sending the query. This is used in the end-to-end monitoring of accelerated queries in multi-tier architectures where Db2 for z/OS handles requests passed on by an application server on behalf of a client application. This allows you to identify queries that were issued by a certain LU Name. | X | |
| Network ID | Network ID of the requester sending the query. This is used in the end-to-end monitoring of accelerated queries in multi-tier architectures where Db2 for z/OS handles requests passed on by an application server on behalf of a client application. This allows you to identify queries that were issued by a certain Network ID. | X | |

Table 39. Selectable columns (continued)

| Column name | Description | Available in IBM Db2 Analytics Accelerator Studio | Available in IBM Data Server Manager |
|---------------------------|---|---|--------------------------------------|
| Original Authorization ID | <p>The original authorization ID. Possible values are:</p> <p>For TSO: The logon ID.</p> <p>For batch: The user ID on the job statement.</p> <p>For IMS (message-driven regions): The sign-on ID, LTERM, ASXBUSR, or PSB name.</p> <p>For IMS (control regions): The user ID on the job statement, or the RACF® started procedure entry if RACF is used.</p> <p>For CICS: The user ID, TERM ID, TRAN ID, or as specified in the resource control table.</p> <p>For MVS™ operator commands and Db2 system internal agents: SYSOPR</p> <p>For a distributed application server (AS):</p> <ul style="list-style-type: none"> • If the application requester (AR) is a Db2 system, then this is the same value that was assigned at the AR. • If the application requester is not a Db2 system, then this is the user ID used to make the initial connection with the application server. <p>For more information, see IFCID 147 - Thread Correlation Data</p> | X | |
| Package Name | <p>The name that identifies a static SQL package or application package. If such a name is displayed, this means that the query was submitted by an application program in the form of a bound package for static SQL processing.</p> | X | |

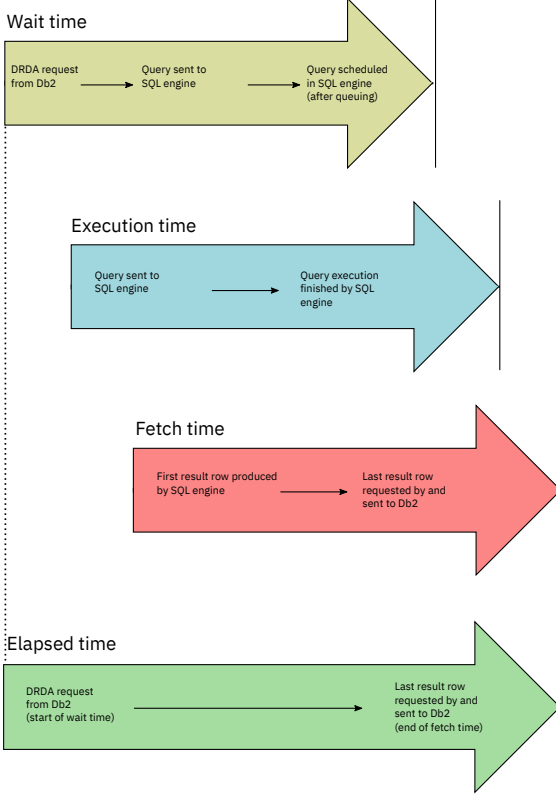
Table 39. Selectable columns (continued)

| Column name | Description | Available in IBM Db2 Analytics Accelerator Studio | Available in IBM Data Server Manager |
|---------------|---|---|--------------------------------------|
| Plan Name | <p>The plan name. It is blank for a Db2 command thread; otherwise:</p> <p>DSNESP RR For SPUFI with repeatable read</p> <p>DSNESP CS For SPUFI with cursor stability</p> <p>DSNUT IL For Db2 utilities</p> <p>DSNTE P2 For DSNTEP2</p> <p>DSNB IN D For binding</p> <p>The application plan name For IMS or CICS</p> <p>A blank plan name For IMS and CICS commands</p> <p>DSQPL AN For QMF</p> <p>The first 8 bytes of the application name For DRDA connections to the common servers</p> <p>For more information, see IFCID 147 - Thread Correlation Data.</p> | X | |
| Priority | <p>The Workload Manager (WLM) importance level that the query or job holds in Db2.</p> <p>For more information, see <i>Mapping of WLM importance levels to Netezza priorities in the IBM Db2 Analytics Accelerator for z/OS: Installation Guide</i>.</p> | X | |
| Product ID | ID of the product (application requester) that routed the query, such as a JDBC driver. | X | |
| Result Size | The data size of the rows that were returned in query results (in MB or GB) from the accelerator to Db2 for z/OS. | X | X |
| Rows Returned | The number of rows that were returned by the accelerator as query results. | X | X |
| SQL Code | The SQL code that is returned to the user after the query or job execution. | X | |
| SQL Text | The SQL statements of recently submitted queries. | X | |
| Start Time | Times when queries were received by IBM Db2 Analytics Accelerator for z/OS. | X | |

Table 39. Selectable columns (continued)

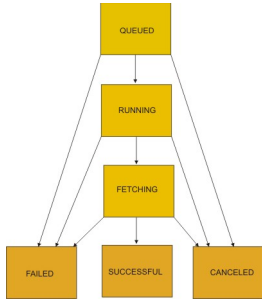
| Column name | Description | Available in IBM Db2 Analytics Accelerator Studio | Available in IBM Data Server Manager |
|-------------|--|---|--------------------------------------|
| State | <p>Processing states that queries are in. The following states are possible:</p> <p>UNKNOWN The state cannot be determined.</p> <p>QUEUED A query has been passed to the Netezza system for processing.</p> <p>RUNNING The query is being processed by the Netezza system.</p> <p>FETCHING The Netezza system has finished processing the query, but Db2 for z/OS has not yet finished collecting the results.</p> <p>FAILED The query did not run to completion because one or more errors occurred.</p> <p>SUCCESSFUL Query execution has been completed successfully.</p> <p>CANCELED The query did not run to completion because it was canceled by a user.</p> <p>With the exception of the UNKNOWN state, each query passes through all the states, unless an error leads to an abnormal ending or a user cancels the query. This is shown in the following diagram:</p>  <pre> graph TD QUEUED[QUEUED] --> RUNNING[RUNNING] RUNNING --> FETCHING[FETCHING] RUNNING --> FAILED[FAILED] RUNNING --> CANCELED1[CANCELED] FETCHING --> SUCCESSFUL[SUCCESSFUL] FETCHING --> CANCELED2[CANCELED] </pre> | X | X |
| User ID | The names of users who submitted past queries. | X | |
| Wait Time | The times that queries had to “spend” in the queue before they were processed by the IBM PureData System for Analytics. | X | X |

Canceling tasks

See how to cancel tasks that are in progress on an accelerator, such as load operations.

About this task

You cancel a task by using the **List Tasks** function. Mind that you cannot use this function to cancel queries. To cancel a running query or an INSERT, UPDATE, or DELETE operation on an accelerator-only table, see *Canceling queries*.

Important: When a load job fails, and you run the command to check the status of the Db2 UNLOAD utility in Db2 for z/OS, you might find numerous UNLOAD threads in the STOPPED state. The stopped threads are ended automatically when you start another load job.

Procedure

1. Open the list of accelerators:

| | |
|--------------------------------------|---|
| IBM Db2 Analytics Accelerator Studio | In the Administration Explorer , go to the Accelerators folder. |
| IBM Data Server Manager | a. Click  in the upper left. b. Select ADMINISTER > Accelerators . |

2. Select the accelerator the task is running on:

| | |
|--------------------------------------|---|
| IBM Db2 Analytics Accelerator Studio | a. In the Object List Editor , double-click the accelerator name. |
| IBM Data Server Manager | a. Select the accelerator in the list. b. Click the Manage button on the toolbar. |

3. Click **List Tasks** on the toolbar.
4. The table in the **List Tasks** window shows all tasks that are currently running on the accelerator. To cancel a task, select it in the table and click **Cancel Selected Task**.

The table that lists the tasks contains the following columns, which give you further details about a task:

Name

The type of the task, for example **Load Tables**.

Execution Time

The time that passed since the start of the task.

Progress

The degree of completeness since the start of the task.

If individual tables were selected for processing, the number denotes the number of records (table rows) that were processed so far.

If an entire schema was selected for processing, the number represents the percentage of completion. The maximum value is 1, denoting 100 percent. Therefore, a value of 0.25 means 25 percent complete.

Progress Message

Additional information about running tasks.

User

The IDs of the users who started the tasks.

5. Click **Close** to close the **List Tasks** window.

Removing tables from an accelerator

Follow the steps in this topic to remove accelerator-shadow tables from an accelerator.

About this task

If a part or all of a table (all partitions) have been archived by the High Performance Storage Saver, then this table (an accelerator-archive table) cannot be removed without first restoring the archived data. After restoring the data, the table remains on the accelerator, but becomes an ordinary accelerator-shadow table, which means that it can be removed.

The table removal task is carried out by the SYSPROC.ACCEL_REMOVE_TABLES stored procedure on your data server. For information about the privileges that are required to run this procedure and further details, see the appropriate section in the *IBM Db2 Analytics Accelerator for z/OS: Stored Procedures Reference*. A link to this document is provided under **Related reference** at the end of this section.

Procedure

1. Open the list of accelerators:

| | |
|--------------------------------------|---|
| IBM Db2 Analytics Accelerator Studio | In the Administration Explorer , go to the Accelerators folder. |
| IBM Data Server Manager | a. Click  in the upper left. b. Select ADMINISTER > Accelerators . |

2. Select the accelerator that contains the tables you want to remove:

| | |
|--------------------------------------|---|
| IBM Db2 Analytics Accelerator Studio | a. In the Object List Editor , double-click the accelerator name. |
| IBM Data Server Manager | a. Select the accelerator in the list. b. Click the Manage button on the toolbar. |

3. If incremental updates are enabled for the tables that you want to remove, first disable incremental updates:

- a) To see the table names, you might have to expand the table schema. To do so, click the twistie in front of the schema name.

Tip: You can select all tables belonging to a schema if you select the check box in front of the schema name:

- In IBM Db2 Analytics Accelerator Studio, just select the schema name.
- In IBM Data Server Manager, select the check box in front of the schema name.

- b) Select the tables that you want to disable.

- c) Select **Replication > Disable Replication** from the toolbar.

4. Click **Remove** on the toolbar.

5. Confirm the removal by clicking **Yes** in the **Remove Table** window.

Related tasks

Including or excluding tables from incremental updates

Incremental updates can be enabled or disabled on the table level. This allows you to select the tables that take part in the process. When a subsystem has been configured for incremental updates, the toolbar

of the accelerator view for regular accelerators shows an extra button, which works like a drop-down menu.

Related information

[IBM DB2 Analytics Accelerator for z/OS: Stored Procedures Reference](#)

Exporting a table specification

You can save a list of the accelerator-shadow tables on an accelerator to an XML file and in a later step import that list for use with another accelerator. This way, tables can be added more quickly than by adding schemas and tables individually.

About this task

A typical use case is an administrator who saves a valid table specification that was created in a test environment in order to use this specification in a production environment. To make the definition work in a different environment, you can edit the XML file with a text editor, and, for example, use the find-and-replace function to replace the names of schemas and tables.

Restriction: This option does not exist in IBM Data Server Manager.

Procedure

1. Click **File > Export**.
2. In the **Export** window, expand the **IBM Db2 Analytics Accelerator** folder to see its contents.
3. Select **Table Specifications**.
4. Click **Next**.
5. In the **Export Table Specification** window, select an appropriate database connection profile.
The profile gives you access to the accelerators that a Db2 subsystem is connected to. Tables are exported from these accelerators. You thus have to select the proper profile, that is, one that gives you, by way of the connected Db2 subsystem, access to the accelerators that contain the right tables. If the proper profile does not exist yet, you can click **New** to create it.
6. Click **Next**.
7. From the **From accelerator** drop-down list, select the accelerator containing the tables to be exported.
8. In the table below, you can see the schemas and tables on the selected accelerator. From this table, you can select the tables or entire schemas whose specification you want to save to an XML file.
If the list is long, first narrow the choice by using the **Name like** filter field. Type the names of schemas or tables in this field, either fully or partially, to display just schemas and tables bearing or starting with that name. The names of tables that have already been selected are grayed out.
9. Click **Browse**.
10. In the **Export to File** window, navigate to the folder in which you want to save your table specification XML file.
11. Type a file name in the **File name** field.
By default, the file is given an extension of `idaa.xml`. Files of this type are encoded in UTF-8.
12. Click **Save**.
You return to the **Export Table Specification** window. The path and the file name of your table specification XML file are displayed in the **To XML file** field.
13. Click **Finish**.

Importing a table specification

You can import a list of accelerator-shadow tables for query acceleration that was previously saved to an XML file.

About this task

A typical use case is an administrator who saves a valid table specification that was created in a test environment in order to use in a production environment. To make the definition work in a different environment, you can edit the XML file with a text editor, and, for example, use the find-and-replace function to replace the names of schemas and tables.

Restriction: This option does not exist in IBM Data Server Manager.

Procedure

1. Click **File > Import**.
2. In the **Import** window, expand the **IBM Db2 Analytics Accelerator** folder to see its contents.
3. Select **Table Specifications**.
4. Click **Next**.
5. In the **Import Table Specification** window, select an appropriate database connection profile.
The profile gives you access to the accelerators that a Db2 subsystem is connected to. Tables are exported from these accelerators. You thus have to select the proper profile, that is, one that gives you, by way of the connected Db2 subsystem, access to the accelerators that contain the right tables. If the proper profile does not exist yet, you can click **New** to create it.
6. Click **Next**.
7. From the **To accelerator** drop-down list, select the accelerator on which you want to define the tables.
8. Click **Browse** to navigate to the folder that contains the XML file with the list of accelerator-shadow tables.
9. In the **Import from File** window, navigate to the proper XML file, select it, and click **Open**.

Important: XML files in UTF-8 format are recommended. Such files start with the following header:

```
<?xml version="1.0" encoding="UTF-8"?>
```

You return to the **Import Table Specification** window. The path and the file name of the selected XML file is displayed in the **From XML** file field.

10. In the table below, you can see the schemas and tables that are listed in the selected XML file. From this list, select entire schemas or individual tables that you want to define on the accelerator.
If the list is long, first narrow the choice by using the **Name like** filter field. Type the names of schemas or tables in this field, either fully or partially, to display just schemas and tables bearing or starting with that name. The names of tables that have already been selected are grayed out.
11. Click **Finish**.

Removing accelerators

Follow the steps in this topic to remove accelerators from the system configuration. Bear in mind that this action will also remove the tables from an accelerator.

About this task

The table removal task is carried out by the following stored procedures on your data server:

- SYSPROC.ACCEL_REMOVE_TABLES
- SYSPROC.ACCEL_REMOVE_ACCELERATOR

For information about the privileges that are required to run these procedures and further details, see *Appendix C. Required access rights* in the *IBM Db2 Analytics Accelerator for z/OS: Stored Procedures Reference*. A link to this document is provided under **Related information** at the end of this section.

Procedure

1. Open the list of accelerators:

| | |
|--------------------------------------|--|
| IBM Db2 Analytics Accelerator Studio | In the Administration Explorer , go to the Accelerators folder. |
| IBM Data Server Manager | <ol style="list-style-type: none"> a. Click  in the upper left. b. Select ADMINISTER > Accelerators. |

2. Select the accelerator:

| | |
|--------------------------------------|--|
| IBM Db2 Analytics Accelerator Studio | In the Object List Editor on the right, select the accelerator that you want to remove. |
| IBM Data Server Manager | In the list of accelerators, select the accelerator name (row). |

3. Remove the accelerator.

| | |
|--------------------------------------|---|
| IBM Db2 Analytics Accelerator Studio | <ol style="list-style-type: none"> a. Click  on the toolbar. b. Confirm the removal by clicking Yes in the Confirm Removing Accelerator window. |
| IBM Data Server Manager | <ol style="list-style-type: none"> a. Click Remove on the toolbar. b. Confirm the removal by clicking Yes in the Remove Accelerator window. |

Related information

[IBM DB2 Analytics Accelerator for z/OS: Stored Procedures Reference](#)

Tracing

IBM Db2 Analytics Accelerator for z/OS offers a variety of predefined trace profiles in case you need diagnostic information. These profiles determine the trace detail level and the components or events that will generate trace information. After collecting the information, you can save it to a file. If your administration client is IBM Db2 Analytics Accelerator Studio, and you have access to the internet, you can directly send the information to IBM by using the built-in FTP function. This method automatically adds the information to an existing IBM support case.

Configuring the trace behavior

IBM Db2 Analytics Accelerator for z/OS provides trace profiles. These profiles consist of lists of components and events that result in the collection of trace information. In addition, they determine the verbosity level of the information, that is, how detailed the trace information will be. Profiles are available for accelerators as well as for stored procedures. In IBM Db2 Analytics Accelerator Studio, you can also use custom profiles that have been saved to an XML file.

About this task

When a traceable event was caused by a component that is covered by the selected profile, trace information about this event is collected and stored in a temporary file.

You can save the temporary trace information to a permanent file or even add the information to a support case (formerly known as problem management record or PMR). Where to save the collected information is configured in another dialog, the **Save Trace** window.

Recommendation: Tracing can have a considerable impact on the system performance. The more verbose the information, the bigger the (negative) impact. Therefore, use the default profiles unless you are instructed otherwise by IBM support.

If none of the available profiles covers your problem scenario, you can ask IBM support for an appropriate profile. If you open a support case, IBM support will give you detailed instructions on how to configure the trace behavior.

Two sets of profiles are available. The first set captures accelerator events; the second events that were caused by stored procedures. The scope of these profile sets is different. Accelerator trace profiles are saved on the selected accelerator. When active, they capture any event on this accelerator, no matter if incidents were caused by an (external) application program or by a function of your administration client. In contrast, stored procedure trace profiles are a part of your administration client. This means that you can only capture events with the help of these profiles if a stored procedure is called by a function of your administration client. Stored procedures that are called from external applications can thus not be traced. Furthermore, the temporary file, which holds the collected trace information about stored procedures, is deleted when you close the administration client. Therefore, to retain access to this information, specify a permanent trace file in the **Save Trace** window.

Using the **Configure Trace** function invokes the SYSPROC.ACCEL_CONTROL_ACCELERATOR stored procedure on your data server. For information about the privileges that are required to run this procedure and further details, see the appropriate section in the *IBM Db2 Analytics Accelerator for z/OS: Stored Procedures Reference*. A link to this document is provided under **Related reference** at the end of this section.

Procedure

1. Connect to the Db2 subsystem that is associated with the accelerator you want to trace:

| | |
|--------------------------------------|--|
| IBM Db2 Analytics Accelerator Studio | Double-click the database-connection-profile icon for that subsystem. |
| IBM Data Server Manager | From the drop-down list on the top banner, select the corresponding database connection. |

2. Open the list of accelerators:

| | |
|--------------------------------------|--|
| IBM Db2 Analytics Accelerator Studio | In the Administration Explorer , go to the Accelerators folder. |
| IBM Data Server Manager | <ol style="list-style-type: none"> a. Click  in the upper left. b. Select ADMINISTER > Accelerators. |

3. Select the accelerator that you want to trace:

| | |
|--------------------------------------|---|
| IBM Db2 Analytics Accelerator Studio | <ol style="list-style-type: none"> a. In the Object List Editor, double-click the accelerator name. |
| IBM Data Server Manager | Select the accelerator (row) in the list. |

4. Open the **Configure Trace** window:

| | |
|--------------------------------------|---|
| IBM Db2 Analytics Accelerator Studio | In the header section at the top of the Accelerator view, click Configure . |
| IBM Data Server Manager | In the lower half of the Accelerator view, click Configure . |

5. To select a profile for accelerator tracing:

| | |
|--------------------------------------|--|
| IBM Db2 Analytics Accelerator Studio | <p>Select one of the profiles from the Profile drop-down list under the heading Accelerator.</p> <p>By default, the currently active trace profile is selected. You can select one of the other standard profiles or a custom profile. A custom profile must be imported before you can select it from the Profile drop-down list. See step “#unique_141/unique_141_Connect_42_accustom” on page 157.</p> <p>You find additional information about the standard profiles in the Description field. The text in this field gives you details about the events that are covered by the profile.</p> <p>To select a custom profile that has been saved to an XML file:</p> <ol style="list-style-type: none"> Click Import. Navigate to the XML file in your file system. Select the file and click OK. Select the custom profile from the Profile drop-down list. |
| IBM Data Server Manager | <p>Select one of the standard profiles from the Accelerator drop-down list.</p> <p>By default, the currently active trace profile is selected.</p> |

6. To select a profile for stored-procedure tracing:

| | |
|--------------------------------------|---|
| IBM Db2 Analytics Accelerator Studio | <p>Select one of the standard profile from the second Profile drop-down list under the heading Stored Procedures.</p> <p>By default, the currently active trace profile is selected. You can select one of the other standard profiles or a custom profile. For importing a custom profile, see step “5” on page 157.</p> |
| IBM Data Server Manager | <p>Select one of the standard profiles from the Stored Procedure drop-down list.</p> <p>By default, the currently active trace profile is selected.</p> |

7. To discard your individual settings and return to the default profiles for both, accelerator tracing and stored-procedure tracing (**DEFAULT** and **Off**):

| | |
|--------------------------------------|--|
| IBM Db2 Analytics Accelerator Studio | Click Restore Defaults . |
| IBM Data Server Manager | a. From the Accelerator drop-down list, select DEFAULT . |

| | |
|--|---|
| | b. From the Stored Procedure drop-down list, select Off . |
|--|---|

8. Click **OK** to save your settings.

Results

The selected profiles remain active until other profiles are selected or until they are reset to the default by the **Reset configuration profiles to default after collecting traces** option. You find this option in the **Save Trace** window.

Related tasks

Saving trace information

The **Save Trace** function saves the collected trace information. In the **Save Trace** window, which opens before the action is completed, you can specify or change the settings for the save operation.

Collecting CDC trace information

None of the options in the **Save Trace** window of IBM Db2 Analytics Accelerator Studio collects trace information about the CDC Capture Agent. This information, however, might be the key to a problem with the incremental update function.

Configuring the FTP server for the Save Trace function

To add trace information to an existing IBM support case, your IBM Db2 Analytics Accelerator Studio client must connect to the IBM RETAIN server on which the support case was created.

Clearing trace information and replication events

The **Clear** function deletes the collected trace information and the replication events (information about incremental updates) from the replication event log.

Related information

[IBM DB2 Analytics Accelerator for z/OS: Stored Procedures Reference](#)

Saving trace information

The **Save Trace** function saves the collected trace information. In the **Save Trace** window, which opens before the action is completed, you can specify or change the settings for the save operation.

About this task

You can specify or change the location of the trace file on your local system. The **Save Trace** window also allows you to include or exclude certain information from the bulk of information that was collected as a result of using a particular profile.

In IBM Db2 Analytics Accelerator Studio, you can also choose to add the Eclipse error log to the trace file, since the information in the Eclipse error log is not generated by an IBM Db2 Analytics Accelerator for z/OS trace profile.

Moreover, you can send trace information to IBM using the file transfer protocol (FTP) to the effect that the trace information is added to an existing support case (formerly known as problem management record or PMR).

Using the **Save Trace** function invokes the SYSPROC.ACCEL_CONTROL_ACCELERATOR stored procedure on your data server. For information about the privileges that are required to run this procedure and further details, see the appropriate section in the *IBM Db2 Analytics Accelerator for z/OS: Stored Procedures Reference*. A link to this document is provided under **Related reference** at the end of this section.

Procedure

1. Open the list of accelerators:

| | |
|--------------------------------------|--|
| IBM Db2 Analytics Accelerator Studio | In the Administration Explorer , go to the Accelerators folder. |
| IBM Data Server Manager | <ol style="list-style-type: none"> Click  in the upper left. Select ADMINISTER > Accelerators. |

2. Select the accelerator that you want to save trace information from:

| | |
|--------------------------------------|--|
| IBM Db2 Analytics Accelerator Studio | <ol style="list-style-type: none"> In the Object List Editor, double-click the accelerator name. |
| IBM Data Server Manager | Select the accelerator (row) in the list. |

3. Open the **Save Trace** window:

| | |
|--------------------------------------|--|
| IBM Db2 Analytics Accelerator Studio | In the header section at the top of the Accelerator view, click Save . |
| IBM Data Server Manager | In the lower half of the Accelerator view, click Save . |

4. Select the information that you want to store in the trace file.

Accelerator trace information

All the information that is captured as a result of your settings in the **Configure Trace** window. This might include the following blocks of information (if applicable). As a user of IBM Db2 Analytics Accelerator for z/OS on premises, you can include or exclude individual blocks:

Traces (includes queries)

An incident protocol that lists the various events and actions that were taken.

Core dumps (may include user data)

An image of the system memory portion that is occupied or shared by IBM Db2 Analytics Accelerator for z/OS processes at a given time.

Important: A core dump contains recent query data among which there might be sensitive information about customers, money transactions and so on. Be careful not to divulge this information to unauthorized parties or individuals.

Netezza core dumps (may include user data)

Netezza core files (files in the `/nz/kit/log/spucore` directory and files detected by the `find /nz/kit/log -type f -name '[0-9]*'` command).

Handle this information with the same care as the IBM Db2 Analytics Accelerator core dumps. See the previous [Important](#) note.

Catalog dumps (includes database schema)

Snapshot of the IBM Db2 Analytics Accelerator for z/OS catalog.

Important: A catalog dump always contains your database schema. Since database schemas are often protected assets, be careful not to divulge this information to unauthorized parties or individuals.

Plans (includes queries)

Netezza execution plans.

Log history

Log information created by the operating system of an accelerator.

Detailed Netezza diagnostics (includes user data)

See the previous [Important](#) note.

nzlogcollector (includes user data)

Produces the same output as an `nzlogcollector` command that is issued from a Netezza machine (`/nz/support/bin/adm/nzlogcollector/nzlogcollector`). The

output presents trace information in a way that is familiar to Netezza experts. The option is available only if you use Netezza Platform Software (NPS) (NPS) 7.2.0.5 or later. See the previous [Important note](#).

Network encryption (IPsec)

Only available if *encryption of data in motion* is enabled. The option collects encryption-related trace information.

Note: When you open the **Save Trace** window from the context menu of the Accelerators folder in IBM Db2 Analytics Accelerator Studio, the **Accelerator trace information** check box and the indented check boxes underneath are inactive. The reason is that selecting the entire Accelerators folder does not allow you to specify or select the particular accelerator in whose trace information you are interested. The **Save Trace** menu choice on the context menu of the Accelerators folder is a kind of “last rescue” option. Without it, there would be no way to submit trace information to IBM in case an error prevents the proper listing of the accelerators in the right pane (accelerators view). If such an error occurs, you have no access to the **Save Trace** function for individual accelerators.

Stored procedure trace information

Trace information that is collected while running stored procedures of IBM Db2 Analytics Accelerator for z/OS, as the result of using a particular profile for stored-procedure tracing in the **Configure Trace** window. Using the check box, you can include or exclude this information from the trace file to be saved.

Eclipse error log (IBM Db2 Analytics Accelerator Studio only)

Error information that is collected by the Eclipse framework, on which the foundation for IBM Db2 Analytics Accelerator Studio, IBM Data Studio, is built. Hence this information does not pertain to errors in IBM Db2 Analytics Accelerator for z/OS, but to its software environment.

5. Where to save the trace file:

| | |
|--------------------------------------|--|
| IBM Db2 Analytics Accelerator Studio | Under the heading Save to local file system , in the Folder field, type the location of the trace file (full directory path) on your local system. Alternatively, you can click Browse to select a folder. |
| IBM Data Server Manager | The trace information will be exported as a zip file to the default download directory in the local file system of the computer used to run IBM Data Server Manager. You cannot change this. |

6. To add the trace information to a support case:

| | |
|--------------------------------------|---|
| IBM Db2 Analytics Accelerator Studio | <ol style="list-style-type: none"> a. Select Add trace information to IBM problem management record (PMR) using FTP to add the selected information to an existing support case. b. In the fields next to PMR number, type the identification number of the support case. c. In the FTP password field, type the password for logging on to the IBM RETAIN server on which the support case was opened. <p>Note: Most IBM FTP servers for support cases accept the registered email address as the password.</p> <p>The currently selected server is displayed in square brackets in the text above the Password field.</p> |
|--------------------------------------|---|

| | |
|-------------------------|---|
| | To change the server or the proxy settings required to access the server, select Window > Preferences > IBM Db2 Analytics Accelerator for z/OS > Save Trace Dialog from the IBM Data Studio main menu. |
| IBM Data Server Manager | <p>a. Select Associate the trace file with the following support case.</p> <p>b. In the Support case ID field, type the support case ID (number) of the support case.</p> |

7. To reset your choices:

| | |
|--------------------------------------|--|
| IBM Db2 Analytics Accelerator Studio | <p>If you want to reset your choices in the Save Trace window to make corrections or start over, click Restore Defaults.</p> <p>Note: This button just undoes all of your recent actions in the Save Trace window. It does not reset profiles and affects your current settings rather than future settings. Compare this with the previous description of the Reset configuration profiles to default after collecting traces check box.</p> |
| IBM Data Server Manager | <p>a. Click Cancel.</p> <p>b. Reopen the Save Trace window by clicking Save again from the Accelerator view.</p> |

8. To revoke all individual settings and in a future run save just the information that is selected by using the default trace profiles, select **Reset configuration profiles to default after collecting traces**. This prevents that verbose trace information consumes too much space on your hard disks. If you want to retain your individual settings after saving them once, clear the **Reset configuration profiles to default after collecting traces** check box or leave it deselected (default).

9. Save your settings:

| | |
|--------------------------------------|---------------------|
| IBM Db2 Analytics Accelerator Studio | Click OK . |
| IBM Data Server Manager | Click Save . |

Related tasks

Configuring the trace behavior

IBM Db2 Analytics Accelerator for z/OS provides trace profiles. These profiles consist of lists of components and events that result in the collection of trace information. In addition, they determine the verbosity level of the information, that is, how detailed the trace information will be. Profiles are available for accelerators as well as for stored procedures. In IBM Db2 Analytics Accelerator Studio, you can also use custom profiles that have been saved to an XML file.

Collecting CDC trace information

None of the options in the **Save Trace** window of IBM Db2 Analytics Accelerator Studio collects trace information about the CDC Capture Agent. This information, however, might be the key to a problem with the incremental update function.

Configuring the FTP server for the Save Trace function

To add trace information to an existing IBM support case, your IBM Db2 Analytics Accelerator Studio client must connect to the IBM RETAIN server on which the support case was created.

Clearing trace information and replication events

The **Clear** function deletes the collected trace information and the replication events (information about incremental updates) from the replication event log.

Related information

[IBM DB2 Analytics Accelerator for z/OS: Stored Procedures Reference](#)

Collecting CDC trace information

None of the options in the **Save Trace** window of IBM Db2 Analytics Accelerator Studio collects trace information about the CDC Capture Agent. This information, however, might be the key to a problem with the incremental update function.

About this task

If you are facing a problem with the incremental update function, provide as much information about the related software components as possible the support team. This includes information about the CDC Capture Agent, which is the part of IBM InfoSphere Change Data Capture for z/OS that runs on z/OS. The support team might even ask you for this type of information. Here is a description on how to obtain it.

Procedure

1. The CDC Capture Agent is just one of the started tasks running on your z/OS system. If you do not know the name of the started task, ask a z/OS systems programmer which task that is.
2. In the SDSF program on z/OS, type XDC in front of the relevant address space output to copy its contents to a sequential data set.
3. Transfer this data set in ASCII mode to your Linux® or Windows workstation and add the resulting txt file to your support case.
4. If a trace dump has been generated, include that information as well. Transfer this data in TERSED format to your workstation because this retains the mainframe-readable formatting of the data during the transfer to a non-mainframe system, and thus ensures that the data remains useful for IBM support. Use an extension of trs for the files.

The TERSED format also reduces the file size. See the documentation for the AMATERSE program if you need further assistance.

Related tasks

[Configuring the trace behavior](#)

IBM Db2 Analytics Accelerator for z/OS provides trace profiles. These profiles consist of lists of components and events that result in the collection of trace information. In addition, they determine the verbosity level of the information, that is, how detailed the trace information will be. Profiles are available for accelerators as well as for stored procedures. In IBM Db2 Analytics Accelerator Studio, you can also use custom profiles that have been saved to an XML file.

[Saving trace information](#)

The **Save Trace** function saves the collected trace information. In the **Save Trace** window, which opens before the action is completed, you can specify or change the settings for the save operation.

[Configuring the FTP server for the Save Trace function](#)

To add trace information to an existing IBM support case, your IBM Db2 Analytics Accelerator Studio client must connect to the IBM RETAIN server on which the support case was created.

[Clearing trace information and replication events](#)

The **Clear** function deletes the collected trace information and the replication events (information about incremental updates) from the replication event log.

Configuring the FTP server for the Save Trace function

To add trace information to an existing IBM support case, your IBM Db2 Analytics Accelerator Studio client must connect to the IBM RETAIN server on which the support case was created.

About this task

The RETAIN server uses the file transfer protocol (FTP) for data transmissions. The IBM Db2 Analytics Accelerator section in the **Preferences** window of IBM Db2 Analytics Accelerator Studio allows you to specify the correct server and connection settings for this operation.

Note: This configuration step is required only for IBM Db2 Analytics Accelerator Studio. In IBM Data Server Manager, you cannot configure the server to send trace information to.

Procedure

1. From the main menu in IBM Db2 Analytics Accelerator Studio, select **Window > Preferences > IBM Db2 Analytics Accelerator > Save Trace Dialog**.
2. In the **Server Name** field, type the name of the IBM RETAIN server.
European IBM customers, for example, use a server called `ftp.ecurep.ibm.com`.
3. In most cases, port 21 is used for FTP transmissions so that you need not change the default entry in the **Port** field.
4. In the **User ID** field, type anonymous.
5. In the **Password** field, type your e-mail address.
For European customers, the logon process is described on the web. See the links under **Related information** at the end.
6. In the **Directory** field, type the path to the directory that you use to dispatch RETAIN data.
7. If your FTP transmission needs to pass a proxy server that is part of your organization's firewall, select **Use SOCKS 5 proxy server** and specify the details of this proxy server:

Note: As the label of the check box suggests, the proxy server needs to comply with the *SOCKS 5* standard.

- a) In the **Address** field, type the host name or IP address of the proxy server.
 - b) In the **Port** field, type the number of the port on which the proxy server listens to outbound requests.
 - c) In the **User ID** field, type a user ID that allows you to send data via the proxy server.
 - d) In **Password** field, type the password belonging to that ID.
8. Click **Apply** to save your settings or **OK** to save your settings and exit the **Preferences** window.

Related tasks

[Configuring the trace behavior](#)

IBM Db2 Analytics Accelerator for z/OS provides trace profiles. These profiles consist of lists of components and events that result in the collection of trace information. In addition, they determine the verbosity level of the information, that is, how detailed the trace information will be. Profiles are available for accelerators as well as for stored procedures. In IBM Db2 Analytics Accelerator Studio, you can also use custom profiles that have been saved to an XML file.

[Saving trace information](#)

The **Save Trace** function saves the collected trace information. In the **Save Trace** window, which opens before the action is completed, you can specify or change the settings for the save operation.

[Collecting CDC trace information](#)

None of the options in the **Save Trace** window of IBM Db2 Analytics Accelerator Studio collects trace information about the CDC Capture Agent. This information, however, might be the key to a problem with the incremental update function.

Clearing trace information and replication events

The **Clear** function deletes the collected trace information and the replication events (information about incremental updates) from the replication event log.

Related information

IBM Enhanced Customer Data Repository Service

IBM Support

Clearing trace information and replication events

The **Clear** function deletes the collected trace information and the replication events (information about incremental updates) from the replication event log.

About this task

The deletion does not include trace information that was saved to a file. Delete trace files manually.

It is not possible to clear the trace information without clearing the replication event log at the same time or vice versa. Postpone the deletion if you still need either information.

Procedure

1. Open the list of accelerators:

| | |
|--------------------------------------|--|
| IBM Db2 Analytics Accelerator Studio | In the Administration Explorer , go to the Accelerators folder. |
| IBM Data Server Manager | <ol style="list-style-type: none"> a. Click  in the upper left. b. Select ADMINISTER > Accelerators. |

2. Select the accelerator to clear trace information from:

| | |
|--------------------------------------|---|
| IBM Db2 Analytics Accelerator Studio | <ol style="list-style-type: none"> a. In the Object List Editor, double-click the accelerator name. |
| IBM Data Server Manager | Select the accelerator (row) in the list. |

3. Clear trace information and replication events:

| | |
|--------------------------------------|---|
| IBM Db2 Analytics Accelerator Studio | In the header section at the top of the Accelerator view, click Clear . |
| IBM Data Server Manager | In the lower half of the Accelerator view, click Clear . |

4. Confirm the deletion:

| | |
|--------------------------------------|---|
| IBM Db2 Analytics Accelerator Studio | In the Confirm Clearing Trace window, click Yes . |
| IBM Data Server Manager | In the Confirm window, click Yes . |

The following message is displayed:

| | |
|--------------------------------------|--|
| IBM Db2 Analytics Accelerator Studio | Existing trace was successfully removed. |
|--------------------------------------|--|

| | |
|-------------------------|---------------------------------------|
| IBM Data Server Manager | Successfully removed existing traces. |
|-------------------------|---------------------------------------|

5. Click **OK**.

Related tasks

Configuring the trace behavior

IBM Db2 Analytics Accelerator for z/OS provides trace profiles. These profiles consist of lists of components and events that result in the collection of trace information. In addition, they determine the verbosity level of the information, that is, how detailed the trace information will be. Profiles are available for accelerators as well as for stored procedures. In IBM Db2 Analytics Accelerator Studio, you can also use custom profiles that have been saved to an XML file.

Saving trace information

The **Save Trace** function saves the collected trace information. In the **Save Trace** window, which opens before the action is completed, you can specify or change the settings for the save operation.

Collecting CDC trace information

None of the options in the **Save Trace** window of IBM Db2 Analytics Accelerator Studio collects trace information about the CDC Capture Agent. This information, however, might be the key to a problem with the incremental update function.

Configuring the FTP server for the Save Trace function

To add trace information to an existing IBM support case, your IBM Db2 Analytics Accelerator Studio client must connect to the IBM RETAIN server on which the support case was created.

Monitoring accelerator usage metrics

Your administration client offers an accelerator monitoring function, which allows you to observe and analyze the usage of accelerator resources, such as CPU, disks, and memory. The function also shows basic replication performance metrics. The function must be configured to show available metrics.

Accelerator usage metrics

The monitoring window of an accelerator shows various usage metrics. Here is a brief description of controls on the monitoring window and the metrics.

General information

The accelerator monitoring window shows several views (tabs) with different information.

On top of each graph or table in a view, you find the time scale slider. By default, the slider is in the leftmost position, which means that the time axis (x-axis) under the graph focuses on events or measurements on the current day. As you drag the slider to the right, the scope broadens, so that the time axis displays the metrics of several days or even weeks. At the same time, the number of measurements per day decreases. The slider is comparable to a zoom-in/zoom-out function. If you slide it back to the left, the scope narrows, and the displayed number of measurements per day increases. You can also move the slider back and forth by using the scroll wheel on your mouse.

System Utilization

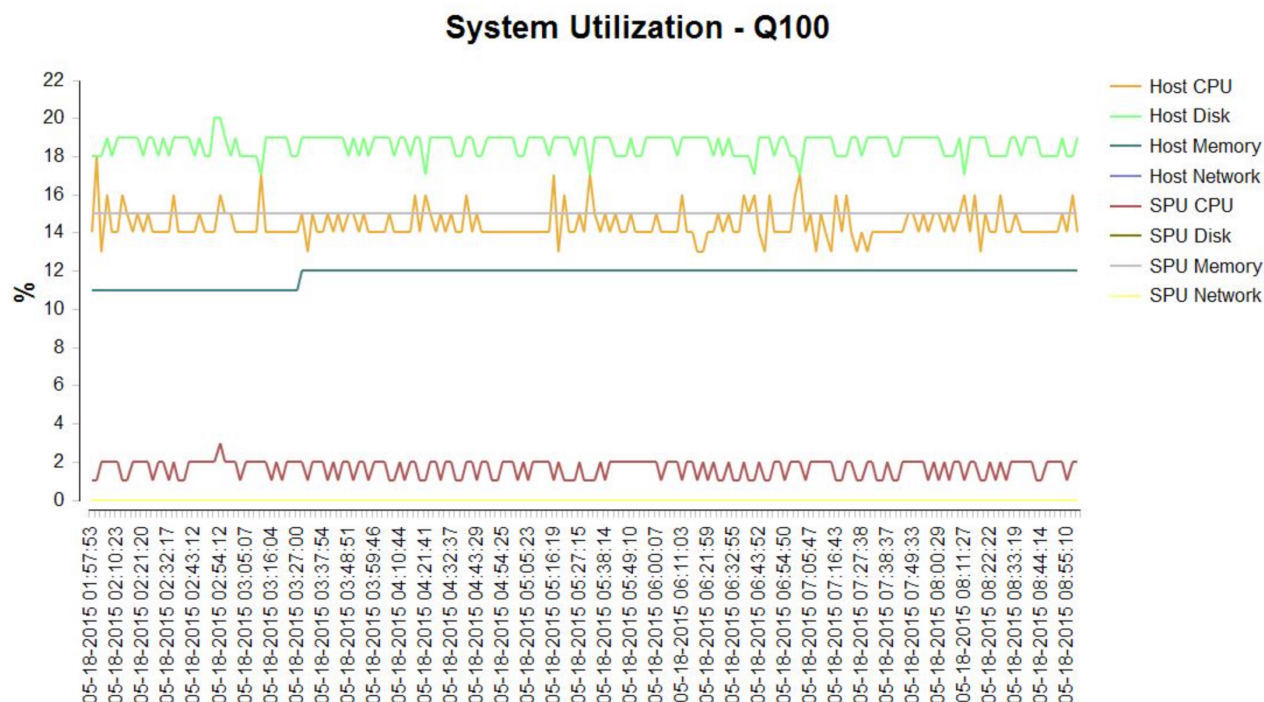

Figure 14. The **System Utilization** view of the accelerator monitoring window

The y-axis shows the different utilization values (metrics) in percent.

The **System Utilization** tab offers a graphical display (curve) of the following metrics:

Host CPU

The utilization of the coordinator node's central processing unit (CPU) in percent

Host Disk

The utilization of the disks used by the coordinator node percent

Host Memory

The utilization of the coordinator node's memory in percent

Host Network

The utilization of the network used for connections to and from the coordinator node in percent

SPU CPU

The overall CPU utilization of the snippet processing units or SPUs (worker nodes) in percent

SPU Disk

The utilization of the disks used by the snippet-processing units (SPUs or worker nodes)

SPU Memory

The overall memory utilization of the snippet processing units or SPUs (worker nodes) in percent

SPU Network

The utilization of the network used for connections to and from the snippet processing units (SPUs) in percent

By default, curves for all these metrics are shown in the graph on the **System Utilization** tab. To focus on just a few of these metrics, you can deselect the others, so that they are hidden from view. To deselect a metric, just click its name on the legend, which you find above the graph. When deselected, the name of a metric is grayed out.

The graph also has a time line. If you drag the time line to the left or to the right, a pop-up window comes into view, which shows the metrics that are related to the position of the time line on the x-axis.

Current Tasks

The **Current Tasks** view gives you a list of the currently running accelerator tasks in a table.

| ID | PID | DBNAME | TYPE | CONNTIME | STATUS | COMMAND | PRIORITY | CID |
|--------|------|----------------------|----------|---------------------|--------|--|----------|-------|
| 131350 | 8237 | DWA_LOCATION_DWEDA14 | sql-odbc | 2015-05-18 07:32:06 | active | GENERATE STATISTICS ON "TPCH30M_E"."REGION-UID_... | 2 | 20389 |
| 131351 | 8249 | SYSTEM | sql | 2015-05-18 07:32:06 | active | select id, pid, dbname, type, conntime, status, translate(c... | 3 | 8248 |

| 20150518 | Plan # | Snippet | Time S/P | State | Busy | Dataslices ... | SQL | Username/Database |
|----------|--------|---------|----------|---------|------|----------------|--|----------------------|
| 07:32:07 | 20093 | (1/8) | 1/1 | waiting | | | GENERATE STATISTICS ON REGION-UID_011800 | DWA_USER_DWEDA14/DWA |

Figure 15. The **Current Tasks** view of the accelerator monitoring window

This table has the following columns:

ID

The task IDs

PID

The process identifiers that the system assigns to running tasks

DBNAME

The names of the Db2 subsystems or data sharing groups involved in the processes

TYPE

The operation type. For example, sql stands for a SQL operation, sql-odbc stands for a SQL command that was received from an ODBC client.

CONNTIME

The connection time, that is, the time that was needed so far to process a task

STATUS

The statuses of the tasks. Values can be active or finished.

COMMAND

The command (code) that was submitted. In the screen capture, you see SQL commands.

PRIORITY

The priority assigned to the tasks

CID

8-digit number

The number in the column header is the current date. The values that the column contains are the start times of the tasks.

Plan

The plan IDs.

Snippet

The currently processed snippet (data slice). For example, 1/8 means the first of eight data slices in total.

Time S/P

State

The processing state of the snippets (data slices)

Busy

Data Slices

SQL

The SQL commands that are processed (if any).

Username/Database

The IDs of the users who started the tasks and the names of the Db2 subsystems or data sharing groups involved

Finished Tasks

The **Finished Tasks** view shows a list of the task history on the selected accelerator.

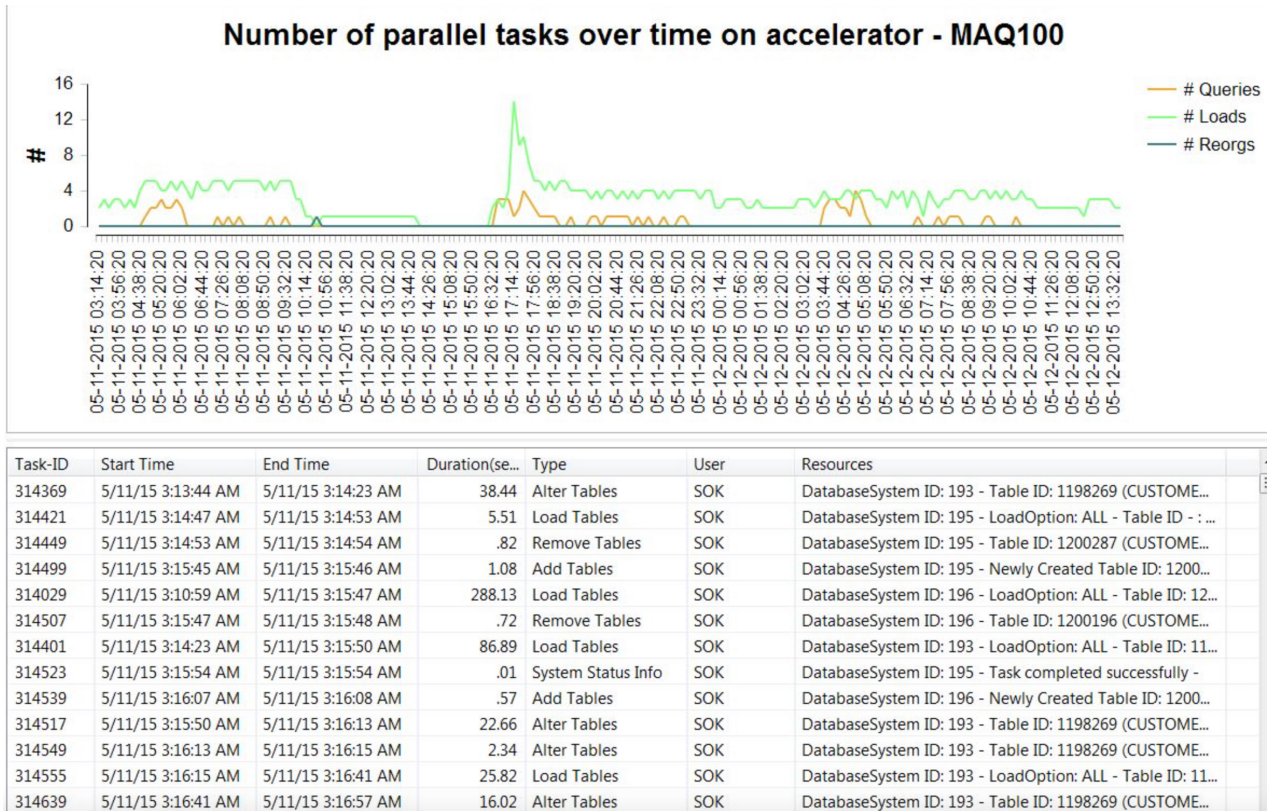

Figure 16. The Finished Tasks view of the accelerator monitoring window

The table has the following columns:

Task-ID

The unique identification numbers of the tasks in the table.

Start Time

The start times of the tasks.

End Time

The completion times of the tasks.

Duration

The times that it took to complete the tasks, in milliseconds.

Type

The types of the tasks that were run on the accelerator, for example, the adding of tables, the alteration of tables, the removal of tables, or the collection of system status information. Note that queries are not listed here.

User

The names of the users who submitted the tasks.

Resources

Identifiers of the objects and processes that were used to complete the tasks, such as database IDs, table IDs, or process descriptions.

Data Slices

Data slices are the chunks of data that are processed by the worker nodes of an accelerator. Exactly one data slice is processed by all worker nodes at a particular time. This can be, for example, a portion of the table rows that must be processed for a query.

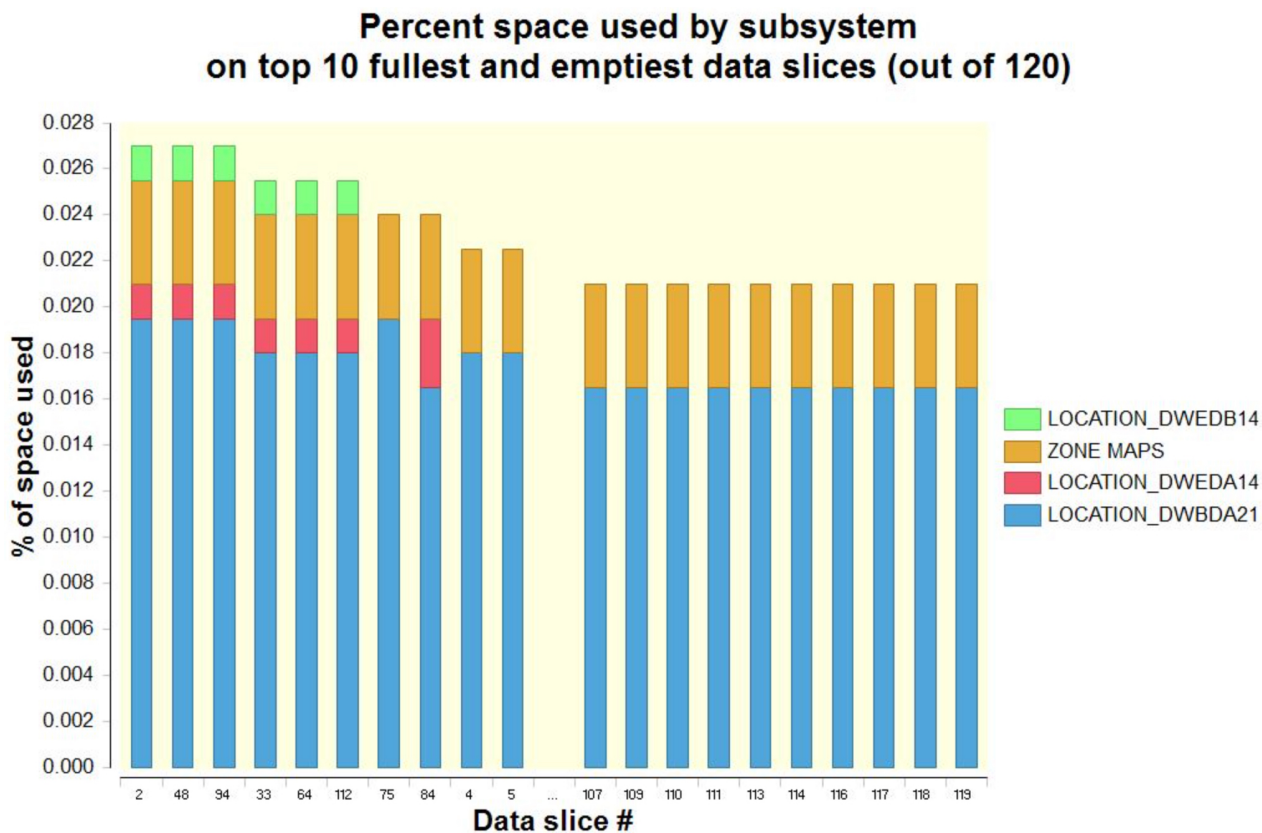

Figure 17. The Data Slices view of the accelerator monitoring window

Incremental Updates

The **Incremental Updates** view of replication metrics is visible only if IBM InfoSphere Change Data Capture for z/OS (CDC) has been configured for the accelerator. In this case, the graphs of this view show the replication workload (the number of inserted, updated and deleted rows in Db2 for z/OS) and the replication latency for the connection between a Db2 for z/OS subsystem or data sharing group and the selected accelerator. You see a graph for each subscription, that is, each Db2 for z/OS subsystem or data sharing group connected to the selected accelerator. Scroll down to view any other graphs that might be.

Replication subscription ACCEL_DWAS9MV4_DWBDB13 on accelerator MAQ50

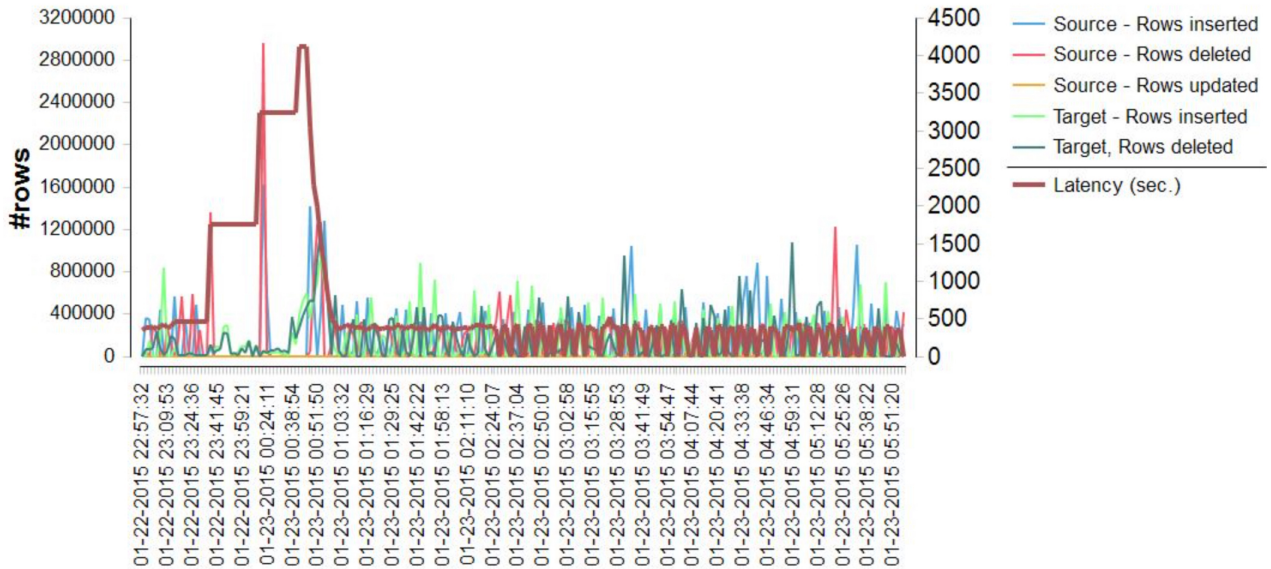

Figure 18. The Incremental Updates view of the accelerator monitoring window

Viewing accelerator usage metrics

The accelerator monitoring view offers graphical displays of various usage metrics and tables containing these metrics. Metrics include the system utilization, the tasks running on an accelerator, the disk space occupied by the data broken down by Db2 subsystems, as well as the replication throughput and the replication latency.

Before you begin

To populate the views (tabs) of the monitoring window, you must provide the corresponding data. This is done by running the SYSPROC.ACCEL_CONTROL_ACCELERATOR stored procedure with the <getTraceData> command. The <getTraceData> command allows you to specify attributes and keywords in the input XML data, which cause the stored procedure to collect the requested data and store it in a trace file on the accelerator.

To obtain the required data and make it available in the accelerator monitoring window:

1. In the input XML string of the stored procedure, add the <getTraceData> command (XML element).
2. Inside of the <getTraceData> element, add a <content> element.
3. Set the value (text) between the <content> tags to SYSTEMUTILIZATION.
4. Run the stored procedure SYSPROC.ACCEL_CONTROL_ACCELERATOR.

The stored procedure call looks like this:

```
CALL SYSPROC.ACCEL_CONTROL_ACCELERATOR
(accelerator_name,
 <getTraceData keepConfiguration="true" >
   <content>SYSTEMUTILIZATION</content>
</getTraceData>,
 result,
 message)
```

Insert values for *accelerator_name*, *result*, and *message* as needed.

For more details, see the description of the SYSPROC.ACCEL_CONTROL_ACCELERATOR stored procedure in the *IBM Db2 Analytics Accelerator for z/OS: Stored Procedures Reference*.

When you open the monitoring window, the information in the most recent trace information on the selected accelerator is used for the display of graphs and tables. However, you can also select other (older) trace files to serve as the information source.

Procedure

1. Open the list of accelerators:

| | |
|--------------------------------------|--|
| IBM Db2 Analytics Accelerator Studio | In the Administration Explorer , go to the Accelerators folder. |
| IBM Data Server Manager | <ol style="list-style-type: none"> a. Click  in the upper left. b. Select ADMINISTER > Accelerators. |

2. Select the accelerator:

| | |
|--------------------------------------|--|
| IBM Db2 Analytics Accelerator Studio | a. Select the accelerator in the Object List Editor . |
| IBM Data Server Manager | a. Select the accelerator in the list. |

3. Click **Monitor** on the toolbar to open the monitoring window.
The monitoring window opens. The **System Utilization** tab is in front.
4. Select the view (tab) of interest.

Setting a refresh interval or a skew threshold

Select **Preferences > IBM Db2 Analytics Accelerator > Accelerator View** from the main menu to set the refresh interval for the **Accelerator** view or the warning threshold for table skew.

Procedure

1. Set values:

- To set or change the interval after which the information in the **Accelerator** view is automatically refreshed, select the appropriate value from the **Automatically refresh information in the Accelerator view** drop-down list. The default is **Every minute**, meaning that the information in the **Accelerator** view is refreshed each time after the passing of one minute.
- To set or change a table skew value that will result in a warning message when it has been exceeded by a very big accelerator-shadow table in the range of 100 million rows, type a decimal number between 0 and 1 in the text field next to **Show a warning if the skew value of very big tables exceeds**. Example: 0.7. The default is 0.25.

Notes:

- What is considered to be *very big* varies with the size of your IBM PureData System for Analytics. On smaller systems, the tables that will cause a warning are smaller and vice versa. The threshold is somewhere in the range between 50 million and 100 million table rows.
- The actual skew value can be greater than 1, and thus you could enter a value greater than one, but for the tables that are affected by the skew threshold (very big accelerator-shadow tables), 1 is already a bad value.

To be able to issue a warning, IBM Db2 Analytics Accelerator Studio must compare the specified skew threshold with the actual skew values of the tables on your accelerators. The actual values are obtained by running the **SYSPROC.ACCEL_GET_TABLES_INFO** stored procedure on your data server. For information about the privileges that are required to run this procedure and further details, see the appropriate section in the *IBM Db2 Analytics Accelerator for z/OS: Stored*

Procedures Reference. A link to this document is provided under **Related reference** at the end of this section.

- To disable checking for unsupported columns, clear the **Check for unsupported columns** check box. By default, this feature is enabled because it tells you beforehand why a table cannot be added or why certain columns were skipped.

Important: For the deactivation to take effect, you must disconnect, then reconnect to the Db2 subsystem. To do so:

- Go to the **Administration Explorer**.
 - In the **All Databases** folder, navigate to the appropriate Db2 subsystem icon.
 - Right-click the icon.
 - Select **Disconnect** from the menu.
 - Double-click the icon to reconnect.
- Click **Apply** to save the changes or **Restore Defaults** to undo the changes.
 - Click **OK** to save your settings and exit the window or just exit the window.

Related information

[IBM DB2 Analytics Accelerator for z/OS: Stored Procedures Reference](#)

Updating accelerator tables continually

The incremental update function of IBM Db2 Analytics Accelerator for z/OS allows you to update accelerator-shadow tables continually. Changes to the data in original Db2 for z/OS tables are thus propagated to the corresponding target tables with a high frequency and just a brief delay. This way, query results from an accelerator are always extracted from recent, close-to-real-time data.

The information about changes to be transferred comes from the Db2 for z/OS log.

In the past, data in accelerator-shadow tables could only be updated by use of the table load function. With this function, you can only update entire tables and entire table partitions, and the latter only if the tables are partitioned by range or partitioned by growth. The incremental update function, in contrast, updates individual table rows. Advantages and disadvantages are connected with either method. [Table 40 on page 172](#) compares the advantages and disadvantages.

| Manual update of entire table using load function | Manual update of entire partitions using load function | Incremental update |
|---|---|--|
| For all types of tables | Only for range-partitioned tables and tables partitioned by growth | For all types of tables |
| Potentially long-running process, depending on the size of the tables | Potentially long-running process, depending on the size of partitions and the distribution of data changes across partitions (the more partitions are involved, the more time-consuming the update becomes) | Short-running process after initial load |
| Fast (up to one TB per hour) | Fast (up to one TB per hour) | Slower (in the range of GBs per hour) |
| Redundant load of table rows that have not changed, resulting in waste of processing resources (MIPS) | Redundant load of table rows that have not changed, resulting in waste of processing resources (MIPS) | No redundant load of table rows, no waste of processing resources. |

Table 40. Comparison of table update methods (continued)

| Manual update of entire table using load function | Manual update of entire partitions using load function | Incremental update |
|--|--|--------------------------------|
| Just a snapshot of the original data at some point in the past | Just a snapshot of the original data at some point in the past | Continual updates, recent data |

Use cases

Incremental updates are the preferable method with regard to the following points of interest:

Realtime business intelligence

If real-time data is very important for your business intelligence operations, incremental updates are the preferable choice. Incremental updates do not guarantee that query data is the most recent available, but the latency is low, and this makes incremental updates a cost-efficient alternative.

Quick reporting on operational data

Incremental updates provide an uncomplicated, easy-to-use, and fast way to reporting on data in an operational data store (ODS) because the function is deeply integrated into your Db2 for z/OS and IBM Db2 Analytics Accelerator for z/OS setup. No up-front extraction and transformation of data is required to obtain results.

Cost-efficiency

Incremental updates are more cost-efficient than traditional update methods because there is no redundancy during updates and hence no waste of processing resources.

In addition, internal tests have shown that running incremental update processes affect the query response time only marginally.

High availability

Incremental updates can be configured in such a way that data changes in a Db2 for z/OS table are propagated to more than one accelerator-shadow table on multiple accelerators. If one accelerator fails, another one can take over to process incoming queries. This happens with just a short delay.

Related tasks

Loading tables

Successful queries against accelerator-shadow tables are possible only if the tables contain data. Therefore, you must load the tables after their definition (empty structure) has been copied to the accelerator.

Making queries wait for incremental updates

To minimize the gap in data recency between the original Db2 for z/OS tables and incrementally updated accelerator-shadow tables (replication latency), you can delay the execution of queries until the latest incremental updates have been applied. This guarantees that an accelerated query against incrementally updated tables always "sees" the latest changes that have been committed in Db2 for z/OS.

This capability fulfills the criteria for Hybrid Transactional Analytical Processing (HTAP). It allows you to run transactional processes as well as analytical queries on a unified data store with a minimized time lag between transactional completion and analytical insight. Informed business decisions can be made much faster, on the basis of much more recent data.

To activate the delay, you must add a special register to your queries. You can also use a ZPARM or bind option to the same effect. The special register is:

```
SET CURRENT QUERY ACCELERATION WAITFORDATA = n.m.
```

where *n.m.* is a decimal number denoting seconds. The minimum is 0.0 (no delay). The maximum is 3600.0 (a delay of one hour).

Important: If you want to use a delay, specify at least 20 seconds. Lower values might work, but you must take the time into account that is needed to scan and read the SYSLOG and to report the findings. Experience has shown that realistic delays are around 20 seconds long.

Example

```
SET CURRENT QUERY ACCELERATION = ENABLE;  
SET CURRENT QUERY ACCELERATION WAITFORDATA = 120.0;  
SELECT * FROM XYZ WHERE [...]
```

The first special register in line 1 enables query acceleration. The second special register sets the delay to 120 seconds. What follows is the SQL code for the query. The execution of the query will be postponed for 120 seconds. During that time, the replication engine tries to apply all committed changes that have accumulated before the query started. If the replication engine cannot finish the job during that period, the query will not be accelerated. The further handling depends on the option set in the first special register and on the expiration behavior configured on the IBM Db2 Analytics Accelerator Console. The first special register is set to ENABLE. That means the query fails if one of the conditions for query acceleration is not met. Let's assume that the conditions can be met; so normally, the query would run on the accelerator. However, the default expiration behavior is to abort a query if the incremental updates cannot be applied in time. Supposing the default behavior is set, the query would indeed fail if not all of the pending incremental updates can be applied in 120 seconds.

How to calculate the proper delay time

You certainly ask yourself how to determine the proper delay time (WAITFORDATA value) for your environment. There are two values by which an initial delay time or starting point can be calculated: the *replication latency* and the *replication velocity*. The replication latency is the time that the incremental update process is lagging behind. The replication velocity is a measure for the speed at which data changes could be applied in the past. You get these two values by running the following Db2 command:

```
-DIS ACCEL(<name>) DETAIL
```

where <name> is the name of the accelerator attached to the Db2 subsystem. If incremental updates have been configured for this pair of Db2 subsystem and accelerator, you find the two values in the command output. For example:

```
...  
CURRENT REPLICATION LATENCY FOR THIS DB2 SYSTEM = 2000 MS  
NUMBER OF SUCCESSFUL QUERY REQUESTS WITH DELAY PROTOCOL FOR ALL DB2 SYSTEMS = 0  
NUMBER OF EXPIRED QUERY REQUESTS WITH DELAY PROTOCOL FOR ALL DB2 SYSTEMS = 1  
REPLICATION VELOCITY = 0.04 DB2 LOG SECONDS APPLIED PER SECOND  
...
```

In this example, The latency is 2000 milliseconds or 2 seconds, and the velocity is 0.04. You get the proper WAITFORDATA value by dividing latency by velocity. For the example, this gives you a WAITFORDATA value of 50 seconds to start with.

See [Note on replication latency](#).

Conditions for the success or failure of a query

Whether a query fails depends on the setting of the SET CURRENT QUERY ACCELERATION special register and on the expiration behavior. It also depends on the type of the table. For accelerator-only tables, the WAITFORDATA option is always ignored because it can be assumed that the data in these tables is always the most recent data available (there is no other data in a Db2 for z/OS source table).

If the WAITFORDATA option has been set for queries that reference incrementally updated tables as well as tables not enabled for incremental updates (loaded tables), the query might fail if loaded tables are to be excluded and the expiration behavior is set to FAIL.

For information on how to configure the expiration behavior and the treatment of loaded tables, see *Configuring the expiration behavior of WAITFORDATA queries* and *Including or excluding loaded tables from WAITFORDATA queries* in the *IBM Db2 Analytics Accelerator for z/OS: Installation Guide*.

Table 41 on page 175 lists the possible combinations of settings and their effect with regard to query processing. It is assumed that an incoming query satisfies the conditions for query acceleration.

Table 41. Settings that influence WAITFORDATA query processing

| CURRENT QUERY ACCELERATION | WAITFORDATA | Expiration behavior | Loaded tables | Query processing |
|----------------------------|-------------|---------------------|---------------|---|
| NONE | N/A | N/A | N/A | Db2 for z/OS |
| ENABLE / ELIGIBLE / ALL | 0.0 | fail | Include | Accelerator |
| | | | Exclude | Query fails |
| | | continue | Include | Accelerator |
| | | | Exclude | Accelerator |
| | > 0.0 | fail | Include | Query fails if outstanding incremental updates cannot be applied within WAITFORDATA period. |
| | | | Exclude | Query fails |
| | | continue | Include | Accelerator. The query might return results that are based on obsolete data |
| | | | Exclude | Accelerator. The query might return results that are based on obsolete data |
| ENABLE WITH FAILBACK | 0.0 | fail | Include | Accelerator |
| | | | Exclude | Db2 for z/OS |
| | | continue | Include | Accelerator |
| | | | Exclude | Accelerator. The query might return results that are based on obsolete data |
| | > 0.0 | fail | Include | Db2 for z/OS |
| | | | Exclude | Db2 for z/OS |
| | | continue | Include | Accelerator. The query might return results that are based on obsolete data |
| | | | Exclude | Db2 for z/OS |

Note: A setting of the *Loaded table* parameter has an effect only if loaded tables are referenced by the query

Dependencies on other processing states, configurations, or product features

Other processing states or the use of certain configuration settings or other product features might affect query processing if WAITFORDATA is enabled (value > 0.0):

- If *continuous incremental updates* are enabled, and one of the tables referenced in the query is currently reloaded, or in the spilling or draining state, the query will fail or be processed by Db2 for z/OS (ENABLE WITH FAILBACK). This is because the end of these processes or table states cannot be predicted, and in most cases, they take much longer than the WAITFORDATA period.
- If *continuous incremental updates* are not enabled, the reload of a table stops the incremental update process. The end of the reload process cannot be predicted. It can easily take several hours. The execution of the query would have to wait until the process has finished and incremental updates are re-enabled. This is probably much more time than a user who is waiting for the results of a query is willing to accept. Therefore, WAITFORDATA queries will fail.
- If partitions of a table have been archived with the High Performance Storage Saver, WAITFORDATA processing can still be used for the active partitions of the table. The archived partitions do not receive incremental updates, so a WAITFORDATA setting will not have an effect.
- A setting of WAITFORDATA > 0.0 is ignored if an external stored procedure is run for in-database analytics or predictive modeling (IBM Netezza Analytics). The external stored procedures are executed immediately, processing whatever data is currently available.
- If workload balancing is used in a high-availability setup, a WAITFORDATA setting > 0.0 might lead to successful or failing queries. The decisive factor is the replication latency of the accelerator that a query is sent to. If the latency is higher than the WAITFORDATA period, the query fails. The problem is that one does not know beforehand to which accelerator a query is sent. The accelerator is picked at random.
- If the product software on the accelerator is back-level, and does not support the WAITFORDATA protocol, a query does not necessarily fail. If CURRENT QUERY ACCELERATION is set to ENABLE, ELIGIBLE, or ENABLE WITH FAILBACK, the query might be processed by Db2 for z/OS. If, on the other hand, the special register is set to ALL, the query will fail. The same applies to the equivalent ZPARM or bind option settings.
- WAITFORDATA processing is not possible if *federated access* has been granted to any of the tables referenced by a query. This is because the reference tables (referencing accelerator-only tables), which represent snapshots of the underlying accelerator-shadow tables, cannot be updated by the same incremental update process, and will inevitably be out-of-sync. A query against such tables will fail.
- If a column has been added to a Db2 for z/OS table (add-column schema change), and the accelerator-shadow table of that table has been enabled for incremental updates, the success of a query with a setting of WAITFORDATA > 0.0 against this table depends on a successful schema synchronization within or before the start of the WAITFORDATA period. That is, the SYSPROC.ACCEL_SYNCHRONIZE_SCHEMA stored procedure or the equivalent function in your administration client must have been run successfully. If the stored procedure or client function has been started, but not yet completed, a successful run of an accelerated query against the table remains uncertain. It might or might not succeed, depending on the completion of the necessary changes to the catalog and the full reflection of the schema change in the accelerator-shadow table.
- You cannot change the distribution key or the organizing keys of a table while incremental updates are enabled. To enable the **Alter Keys** function, you must first disable replication, and that means that a setting of WAITFORDATA > 0.0 will have no effect.
- A failure of the active Netezza host has the effect that all queries with a WAITFORDATA setting will fail. However, these queries will be restarted and processed as usual after the passive host has taken over (failover).
- Treatment of date, time, and timestamp values: An accelerated query that retrieves dates might give you the same values as Db2 for z/OS, but a query that selects time values or timestamps will probably produce different results. The reason is that the WAITFORDATA period and the difference between the z/OS system clock and the accelerator's system clock (≤ 7 seconds) are added to these values while the incremental updates are being applied.

Related information

[IBM Db2 Analytics Accelerator for z/OS: Installation Guide](#)

Starting or stopping incremental updates

When a Db2 subsystem has been configured for incremental updates, you can start or stop incremental updates for attached accelerators from the corresponding accelerator views in your administration client. Using the functional links in the header starts or stops incremental updates for an entire accelerator.

About this task

When a subsystem has been configured for incremental updates, the header of the accelerator view for regular accelerators shows an additional entry, which is labeled **Replication**. Next to this label, you find a status indicator and a functional link. Status indicator and link vary according to the current status of the accelerator. For example, if incremental updates have been stopped, the status indicator shows *Stopped* and a functional link labeled **Start**. This is reversed to *Started* and **Stop** when incremental updates have been started. The following statuses are possible:

Disabled

The incremental update function has not been configured for this accelerator and is therefore not available.

Configured

The incremental update function is available for this accelerator, but accelerator-shadow tables have not yet been added to the process.

Error

The incremental update function has been configured, but cannot be started due to an error.

Started

The incremental update function is running and updates are applied to accelerator-shadow tables that have been included in the process.

Stopped

The incremental update function is available and accelerator-shadow tables have been included in the process. However, the function is not running right now.

See Table 42 on page 177.

| IBM Db2 Analytics Accelerator Studio | IBM Data Server Manager | | | | | | | | | | | | | | | | | | | | | | | | | | | | | | |
|---|-------------------------|--------|---------------|------------------|-------------------|-------------------|--------|---|--------|---------------|---|--------|-----------|---|---|---------|------------------|------------------|------------|---|---|---------|------------------|------------------|------------|---|---|---------|------------------|------------------|--|
| <p>Accelerator: VMNPS04 @ DWEDA11</p> <p>Acceleration: Unknown Start Stop Credentials valid since: 11/13/12 6:56 PM Update</p> <p>Status: Unknown Trace: DEFAULT / OFF Configure Save Clear</p> <p>Used space: N/A Active queries: N/A</p> <p>Replication: Stopped Start Replication latency: Stopped Show events</p> <p>► Query Statistics</p> <p>► About</p> <p>▼ Tables (3 of 3 loaded / 3 of 3 enabled for acceleration)</p> <p>Add... Alter Keys... Remove Load... Acceleration Storage Saver Replication</p> <table border="1"><thead><tr><th>Name</th><th>Size</th><th>Rows</th><th>Acceleration</th><th>Last Load</th><th>Replication Since</th></tr></thead><tbody><tr><td>IUTEST</td><td>-</td><td>3 of 3</td><td>3 of 3 tables</td><td>-</td><td>3 of 3</td></tr><tr><td>CUSTOMERA</td><td>-</td><td>-</td><td>Enabled</td><td>11/16/12 1:21 PM</td><td>11/16/12 1:21 PM</td></tr><tr><td>CUSTOMERA2</td><td>-</td><td>-</td><td>Enabled</td><td>11/16/12 1:21 PM</td><td>11/16/12 1:21 PM</td></tr><tr><td>CUSTOMERA3</td><td>-</td><td>-</td><td>Enabled</td><td>11/16/12 1:21 PM</td><td>11/16/12 1:21 PM</td></tr></tbody></table> | Name | Size | Rows | Acceleration | Last Load | Replication Since | IUTEST | - | 3 of 3 | 3 of 3 tables | - | 3 of 3 | CUSTOMERA | - | - | Enabled | 11/16/12 1:21 PM | 11/16/12 1:21 PM | CUSTOMERA2 | - | - | Enabled | 11/16/12 1:21 PM | 11/16/12 1:21 PM | CUSTOMERA3 | - | - | Enabled | 11/16/12 1:21 PM | 11/16/12 1:21 PM | <p>IBM Data Server Manager</p> <p>Administer / Accelerators</p> <p>Diagnostics</p> <p>Used Space : Not Available</p> <p>Credentials Valid Since : 1/27/20 1:42 PM</p> <p>Trace</p> <p>Trace : DEFAULT/OFF</p> <p>Queries</p> <p>Active Queries : 0 (0 queued)</p> <p>Query History : 100 successful -1 fi</p> <p>Monitoring</p> <p>Queue : Avg. wait time: N/A</p> <p>CPU cost : Query Execution: N/A</p> <p>Replication</p> <p>Replication Status : STARTED Stop</p> <p>Replication Latency : Low Show Events</p> |
| Name | Size | Rows | Acceleration | Last Load | Replication Since | | | | | | | | | | | | | | | | | | | | | | | | | | |
| IUTEST | - | 3 of 3 | 3 of 3 tables | - | 3 of 3 | | | | | | | | | | | | | | | | | | | | | | | | | | |
| CUSTOMERA | - | - | Enabled | 11/16/12 1:21 PM | 11/16/12 1:21 PM | | | | | | | | | | | | | | | | | | | | | | | | | | |
| CUSTOMERA2 | - | - | Enabled | 11/16/12 1:21 PM | 11/16/12 1:21 PM | | | | | | | | | | | | | | | | | | | | | | | | | | |
| CUSTOMERA3 | - | - | Enabled | 11/16/12 1:21 PM | 11/16/12 1:21 PM | | | | | | | | | | | | | | | | | | | | | | | | | | |

Important: Using the functional link starts or stops the incremental update process for all tables that have been enabled for incremental updates on the selected accelerator.

Procedure

1. Start your administration client.
2. Connect to the Db2 subsystem that is associated with the proper accelerator.

| | |
|--------------------------------------|--|
| IBM Db2 Analytics Accelerator Studio | Double-click the database-connection-profile icon for that subsystem. |
| IBM Data Server Manager | From the drop-down list on the top banner, select the corresponding database connection. |

3. Open the list of accelerators:

| | |
|--------------------------------------|--|
| IBM Db2 Analytics Accelerator Studio | In the Administration Explorer , go to the Accelerators folder. |
| IBM Data Server Manager | <ol style="list-style-type: none"> a. Click  in the upper left. b. Select ADMINISTER > Accelerators. |

4. Select the accelerator for which you want to start or stop incremental updates:

| | |
|--------------------------------------|---|
| IBM Db2 Analytics Accelerator Studio | <ol style="list-style-type: none"> a. In the Object List Editor, double-click the accelerator name. |
| IBM Data Server Manager | Select the accelerator (row) in the list. |

5. Start or stop incremental updates by taking one of the following actions:

- To start incremental updates, click **Start** in the header of the accelerator view. The status, which is labeled **Replication** or **Replication Status** in the header of the **Accelerator** view, changes to *Started*.
- To stop incremental updates, click **Stop** in the header of the accelerator view. This opens the **Stop Replication** window, in which you can select between the following options for stopping the incremental update process:

Controlled

Completes all work in progress before stopping the process.

Immediate

Stops the process without completing work in progress. Compared with the **Controlled** option, using this option causes a restart of the process to take longer.

Restriction: If *continuous incremental updates* are enabled, and you stop replication inadvertently while a regular reload of a replication-enabled accelerator-shadow table is taking place (started by the load function or the SYSPROC.ACCEL_LOAD_TABLES stored procedure), the table state changes to *Suspended* after the load. That is, the table is treated like a faulty table. To re-enable incremental updates for this table, restart replication on the accelerator and reload the table again.

Click **OK** after selecting an option. You return to the accelerator view, which now shows a replication status of *Stopped*.

Including or excluding tables from incremental updates

Incremental updates can be enabled or disabled on the table level. This allows you to select the tables that take part in the process. When a subsystem has been configured for incremental updates, the toolbar

of the accelerator view for regular accelerators shows an extra button, which works like a drop-down menu.

Before you begin

An accelerator-shadow table can only be included in the incremental update process if it contains data, that is, if it has been loaded.

When loading a table, make sure that the lock mode **TABLE_SET** is selected because this guarantees that data changes will not go amiss during the time between unloading the table data from Db2 to the accelerator and the point where the incremental update process sets in.

If you have enabled *continuous incremental updates* (a mode of operation in which incremental updates are not stopped when a table load begins), you can select lock mode **ROW** for a better performance. This lock mode effects a faster propagation of changes because the incremental updates are not put on halt when a table load starts and continue after the load, but are written to a spill queue, which is drained in the course of events. However, this comes at the price of a slower load process because lock mode **ROW** prevents the loading of the temporary table, which eventually replaces the former accelerator-shadow table. That is, loads are executed as a series of row changes. Decide whether faster loads or faster incremental updates are more important to you.



Attention:

- A risk of data loss exists if you include tables without a unique constraint, such as a primary key or a unique index. To identify rows in such a table, the values of all table columns are used. It is possible that rows with exactly the same values exist, in which case it is impossible to identify a row unambiguously. Hence a deletion of a single row from a table in Db2 for z/OS results in the deletion of this row and all its duplicates from the corresponding accelerator-shadow table. This, in turn, leads to incorrect results for accelerated queries.
- When lock mode ROW is set, Db2 data is unloaded at isolation level CS (cursor stability). Whether a row, a page, or an entire table is locked is determined by the LOCKSIZE defined for the table space of the source tables. To avoid deadlocks during the draining of the spill queue, set this table space to LOCKSIZE ROW if you want to use lock mode ROW for your incrementally updated tables.
- If you update Db2 for z/OS tables by running the LOAD utility rather than an INSERT, UPDATE, or DELETE operation, you must set the following parameters (for the LOAD utility):
 - SHRLEVEL CHANGE
 - LOG YES

Otherwise, the changes that were made by the LOAD utility are not detected by the incremental update function, and will thus not be reflected in your accelerator-shadow tables.

- The Db2 attribute DATA CAPTURE is added to the tables on an accelerator. The attribute can carry the value Y or N (default), for *yes* or *no*. When incremental updates are enabled for a table, the DATA CAPTURE attribute of the table is set to the value Y. Once set, this attribute value persists, even if the table is disabled at a later time. Bear this in mind, especially if you run applications that use the DATA CAPTURE attribute.
- You might have to reload or even remove tables from an accelerator after the execution of an ALTER TABLE or ALTER TABLESPACE statement in Db2 for z/OS. For more information, see *What to do after changing a table or table space in Db2 for z/OS*. You find a **Related reference** link at the end of this topic.

About this task

Two different situations must be considered before adding tables to an incremental update process:

- An accelerator-shadow table has not yet been loaded, that is, it is in *Initial load pending* state. If you enable such a table, and load it immediately thereafter, the tables in Db2 and on the accelerator are in sync. No data changes will be lost because the table contents are the same at the outset and the incremental update process captures all future changes and propagates these to the accelerator.

Tables of this type show the same timestamp in the **Last Load** and **Replication Since** columns of the **Accelerator** view. Compare the tables listed in both images in [Table 43](#) on [page 180](#).

- An accelerator-shadow table has already been loaded when it is added to the incremental update process. In this case, it is likely that the tables are out of sync because data changes might have been applied to the original Db2 table, and not been reflected in the corresponding accelerator-shadow table because the last manual update of the table was before these changes happened. If a safety mechanism was not in place, such tables would continue to be out of sync because the incremental update process can only capture and propagate changes that occur in the future. To avoid this, the status of such tables changes to *Initial load pending* when incremental updates are enabled. This state enforces a complete reload of the tables before they can be used, so that the synchronization gap is closed before the incremental update process sets in.

Important: If the load fails for some of the selected tables, incremental updates are automatically disabled for these tables.

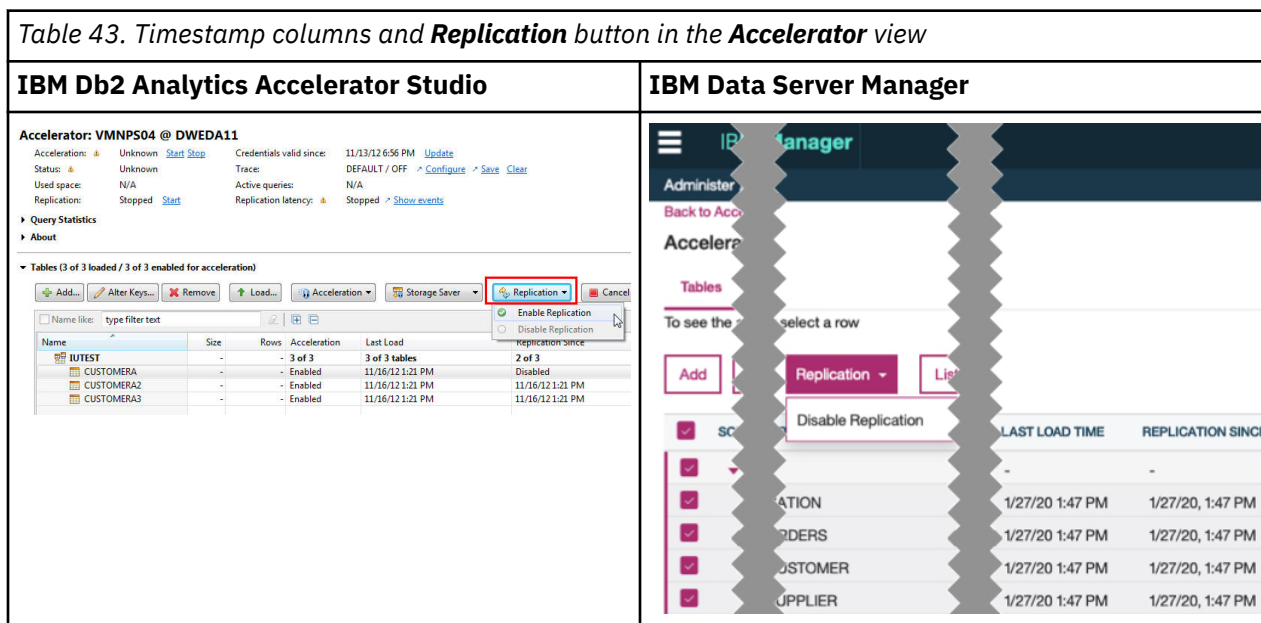

If continuous incremental updates are enabled (see *Enabling continuous incremental updates* in the *IBM Db2 Analytics Accelerator for z/OS: Installation Guide*, the **Replication Since** column shows the following states in the order indicated as soon as a load process begins:

1. *Suspended*
2. *Refreshing*

The *Refreshing* state is shown until the last change has been drained from the spill queue. When you move the mouse pointer over the *Refreshing* label, the current processing phase is displayed in a tool-tip window. The refresh process consists of the following phases:

Pending

The table load process was started, but no data has yet been transferred. Therefore, only the data that has been transferred before the refresh is available for accelerated queries.

Spilling

The table load is in progress, and data is being transferred. Incremental updates that occur during this time are written to the spill queue. Therefore, only the recently transferred load data is available for accelerated queries.

Draining

The load has finished and the changes that have been collected in the spill queue are being applied. Only the data changes that have already been transferred to the table are available for accelerated queries.

Tip: If a table remains in the draining phase for several hours, you are probably in the very rare situation in which new changes arrive in the spill queue faster than they can be drained from it, so that the draining phase never ends (infinite drain). In this case, stop incremental updates completely for a while.

Restriction: It is not possible to enable tables if the table name or the schema name contains GB18030 characters (Simplified Chinese) of Unicode plane 2 (U+20000-U+2FFFF: Supplementary Ideographic Plane). Trying to do so results in an error.

Procedure

1. Connect to the Db2 subsystem that is associated with the accelerator on which the tables reside:

| | |
|--------------------------------------|--|
| IBM Db2 Analytics Accelerator Studio | Double-click the database-connection-profile icon for that subsystem. |
| IBM Data Server Manager | From the drop-down list on the top banner, select the corresponding database connection. |

2. Open the list of accelerators:

| | |
|--------------------------------------|--|
| IBM Db2 Analytics Accelerator Studio | In the Administration Explorer , go to the Accelerators folder. |
| IBM Data Server Manager | <ol style="list-style-type: none"> a. Click  in the upper left. b. Select ADMINISTER > Accelerators. |

3. Select the proper accelerator:

| | |
|--------------------------------------|--|
| IBM Db2 Analytics Accelerator Studio | In the Object List Editor , double-click the accelerator name. |
| IBM Data Server Manager | <ol style="list-style-type: none"> a. Select the accelerator (row) in the list. b. Click Manage on the toolbar. |

4. Select the accelerator-shadow tables to be included or excluded.

In IBM Data Server Manager, the table selection results in the display of additional buttons on the toolbar.

5. Include or exclude tables from the process:

- To include selected tables in the incremental update process, select **Replication > Enable Replication** from the toolbar. See the images in [Table 43 on page 180](#) for the location of the buttons.
- To exclude selected tables from the incremental update process, select **Replication > Disable Replication**.

6. If you have disabled the selected tables, click **Start** in the header of the **Accelerator** view to restart the incremental update process for the remaining enabled tables.

Also note that incremental updates are not restarted automatically if you enable just one table and the steps involved are completed in this order:

- a. Define the accelerator-shadow table.
- b. Enable incremental updates for this table.
- c. Load the accelerator-shadow table.
- d. Start incremental updates (**Replication > Start**).
- e. Reload the accelerator-shadow table.

Normally, when this is done for more than one table, incremental updates continue or are restarted for all tables that are not being loaded or where loading has been finished, which finally results in an automatic restart for all tables. In this special case (just one table), however, you must restart incremental updates manually after the reload.

Related reference

[What to do after changing a table or table space in Db2 for z/OS](#)

In a number of cases, an ALTER TABLE or ALTER TABLESPACE statement in Db2 for z/OS does not involve maintenance work on your accelerator-shadow tables. There are cases, however, in which it does. See which steps you might have to take.

Related information

[CREATE TABLESPACE](#)

Monitoring incremental updates

You can monitor the changes to accelerator tables that result from incremental updates. The header of the **Accelerator** view in your administration client provides an additional line of information when incremental updates have been configured for the accelerator. This line of information is labeled **Replication latency**.

One of the following values is displayed next to this label:

Stopped

Incremental updates have been stopped for the entire accelerator.

Low

It will take less than three minutes to propagate recent changes to the corresponding accelerator-shadow tables.

Medium

Recent changes to the original Db2 tables will be propagated to the corresponding accelerator-shadow tables within three and six minutes.

High

It will take six minutes or longer to apply recent changes to Db2 tables to the corresponding accelerator-shadow tables.

When you move the mouse pointer over the latency value in IBM Db2 Analytics Accelerator Studio, a pop-up window shows the following information:

Target Agent

Operations completed by the incremental update function.

Inserts

Number of row inserts in accelerator-shadow tables that have been included in the incremental update process.

Deletes

Number of row deletions from accelerator-shadow tables that have been included in the incremental update process.

Restriction: This feature is currently not included in IBM Data Server Manager.

Remember:

- An UPDATE is a DELETE followed by an INSERT, so these two figures account for all incremental updates that have been applied.
- Since an UPDATE in Db2 is a DELETE followed by an INSERT on the accelerator side, the values can be different from those in Db2 for z/OS (see **Source Agent**). Furthermore, multiple operations on a single row within a short time might be reported as just one single operation.
- If a load operation is in progress and lock mode **Row** has been selected, the original Db2 tables are not locked during the load. Hence it is possible to INSERT new rows into the Db2 tables even though a load is taking place. If incremental updates are enabled for the same tables, the incremental update function stores these new rows in the spill queue until the load has finished, and applies

these changes thereafter (draining the spill queue). In the course of a drain, a DELETE and an INSERT operation is carried out for each row in the affected accelerator-shadow tables. The DELETE deletes the row that was inserted by the previous load operation, and the INSERT adds this row again (applies the latest change) . This has the effect that the number of **Deletes** increases in cases like this.

See Table 44 on page 183.

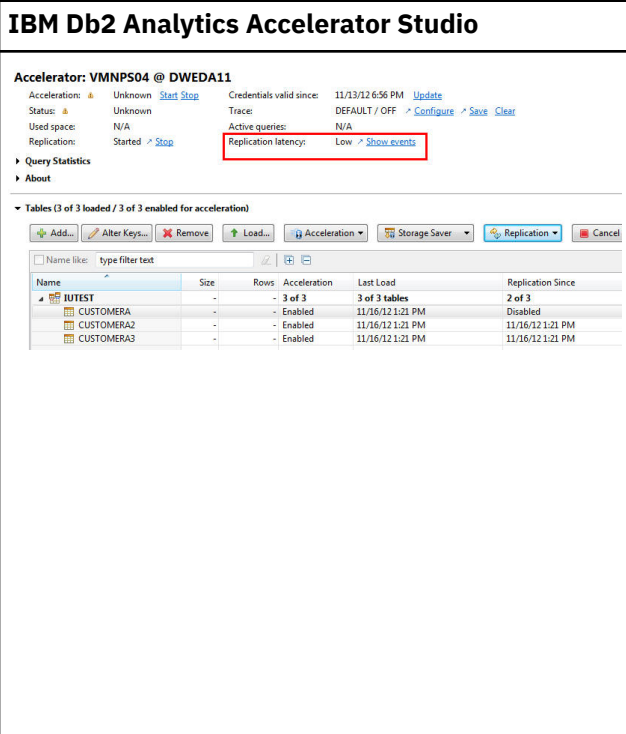
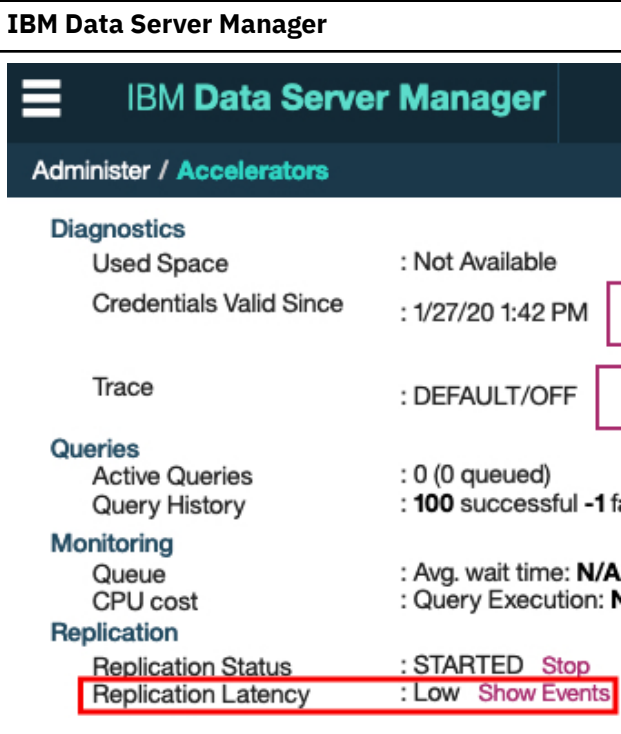
| Table 44. <i>Replication latency in the Accelerator view</i> | | | | | | | | | | | | | | | | | | | | | | | | | | | | | | | |
|--|------|--------|---------------|------------------|-------------------|-------------------|--------|---|--------|---------------|------------------|--------|-----------|---|---|---------|------------------|----------|------------|---|---|---------|------------------|------------------|------------|---|---|---------|------------------|------------------|--|
|  <p>IBM Db2 Analytics Accelerator Studio</p> <p>Accelerator: VMNPS04 @ DWEDA11 Acceleration: Unknown Start Stop Credentials valid since: 11/13/12 6:56 PM Update Status: Unknown Trace: DEFAULT / OFF Configure Save Clear Used space: N/A Active queries: N/A Replication: Started Stop Replication latency: Low Show events</p> <p>Query Statistics About</p> <p>Tables (3 of 3 loaded / 3 of 3 enabled for acceleration)</p> <table border="1"> <thead> <tr> <th>Name</th> <th>Size</th> <th>Rows</th> <th>Acceleration</th> <th>Last Load</th> <th>Replication Since</th> </tr> </thead> <tbody> <tr> <td>INTEST</td> <td>-</td> <td>3 of 3</td> <td>3 of 3 tables</td> <td>11/16/12 1:21 PM</td> <td>2 of 3</td> </tr> <tr> <td>CUSTOMERA</td> <td>-</td> <td>-</td> <td>Enabled</td> <td>11/16/12 1:21 PM</td> <td>Disabled</td> </tr> <tr> <td>CUSTOMERA2</td> <td>-</td> <td>-</td> <td>Enabled</td> <td>11/16/12 1:21 PM</td> <td>11/16/12 1:21 PM</td> </tr> <tr> <td>CUSTOMERA3</td> <td>-</td> <td>-</td> <td>Enabled</td> <td>11/16/12 1:21 PM</td> <td>11/16/12 1:21 PM</td> </tr> </tbody> </table> | Name | Size | Rows | Acceleration | Last Load | Replication Since | INTEST | - | 3 of 3 | 3 of 3 tables | 11/16/12 1:21 PM | 2 of 3 | CUSTOMERA | - | - | Enabled | 11/16/12 1:21 PM | Disabled | CUSTOMERA2 | - | - | Enabled | 11/16/12 1:21 PM | 11/16/12 1:21 PM | CUSTOMERA3 | - | - | Enabled | 11/16/12 1:21 PM | 11/16/12 1:21 PM |  <p>IBM Data Server Manager</p> <p>Administer / Accelerators</p> <p>Diagnostics</p> <p>Used Space : Not Available Credentials Valid Since : 1/27/20 1:42 PM</p> <p>Trace : DEFAULT/OFF</p> <p>Queries</p> <p>Active Queries : 0 (0 queued) Query History : 100 successful -1 f</p> <p>Monitoring</p> <p>Queue : Avg. wait time: N/A CPU cost : Query Execution: N</p> <p>Replication</p> <p>Replication Status : STARTED Stop Replication Latency : Low Show Events</p> |
| Name | Size | Rows | Acceleration | Last Load | Replication Since | | | | | | | | | | | | | | | | | | | | | | | | | | |
| INTEST | - | 3 of 3 | 3 of 3 tables | 11/16/12 1:21 PM | 2 of 3 | | | | | | | | | | | | | | | | | | | | | | | | | | |
| CUSTOMERA | - | - | Enabled | 11/16/12 1:21 PM | Disabled | | | | | | | | | | | | | | | | | | | | | | | | | | |
| CUSTOMERA2 | - | - | Enabled | 11/16/12 1:21 PM | 11/16/12 1:21 PM | | | | | | | | | | | | | | | | | | | | | | | | | | |
| CUSTOMERA3 | - | - | Enabled | 11/16/12 1:21 PM | 11/16/12 1:21 PM | | | | | | | | | | | | | | | | | | | | | | | | | | |

Using the event viewer for incremental updates

The event viewer shows system messages that are related to incremental update processes. It is equipped with various filtering options to facilitate the search for particular messages.

About this task

The event viewer shows a log entry for each system event that occurred in connection with incremental updates. The entries are listed in a table, which contains the following columns:

Type or Severity

The type of the event or message connected with the event. Possible types are **Error**, **Warning**, and **Information**.

Message

The message code and the starting text of the event message. The full message is displayed in the **Message** window on the lower right.

Event ID

The unique identifier of the event.

Originator

The component that issued a message.

Time

The time at which an event occurred.

Procedure

- To open the event viewer:
 - Connect to the Db2 subsystem that is associated with the replication-enabled accelerator.
This must be an accelerator that is included in the incremental update process. That is, incremental updates must be configured for the Db2 subsystem to which the accelerator is attached.

| | |
|--------------------------------------|--|
| IBM Db2 Analytics Accelerator Studio | Double-click the database-connection-profile icon for that subsystem. |
| IBM Data Server Manager | From the drop-down list on the top banner, select the corresponding database connection. |

- Open the list of accelerators:

| | |
|--------------------------------------|--|
| IBM Db2 Analytics Accelerator Studio | In the Administration Explorer , go to the Accelerators folder. |
| IBM Data Server Manager | <ol style="list-style-type: none"> Click  in the upper left. Select ADMINISTER > Accelerators. |

- Select the replication-enabled accelerator:

| | |
|--------------------------------------|--|
| IBM Db2 Analytics Accelerator Studio | a. In the Object List Editor , double-click the accelerator name. |
| IBM Data Server Manager | Select the accelerator (row) in the list. |

- Open the event viewer:

| | |
|--------------------------------------|--|
| IBM Db2 Analytics Accelerator Studio | Click the Show events link in the header of the Accelerator view . |
| IBM Data Server Manager | Next to the Replication Latency value in the Accelerator view , click Show Events . |

Note: The current replication status of the accelerator (*Started, Stopped, or Error*) is irrelevant.

- Selecting a message in the **Replication Events** window has the following effect:

| | |
|--------------------------------------|---|
| IBM Db2 Analytics Accelerator Studio | The main column values are displayed in the Event Details section on the lower left, and the full message text is displayed in the Message window on the lower right. |
| IBM Data Server Manager | The full message text is displayed at the bottom of the window. |

- Using the **View** drop-down list on the upper right, you can hide all messages of an event type that is different from the selected type. To apply this type of filter, click the **Run** button after selecting an event type from the drop-down list.
For example, if you select **Error** and **Run**, only error messages and messages with a severity higher than *error* are displayed.
The underlying mechanism is the same as for the classification of trace information. The lower the severity of the selected information type, the more verbose is the information that is displayed. While the **Error** type provides information about errors and even severer events only, the **Warning** type provides information about warnings, errors, and severer events. That is, each information type with a lower severity includes the information of the types with a higher severity.

- Using the **Show** drop-down list, you can select a time frame for the messages to be displayed. To apply this type of filter, click the **Run** button after selecting a time frame from the drop-down list. For example, if you select **Last 24 hours** and **Run**, the event viewer shows all events that happened during the last 24 hours.

In IBM Db2 Analytics Accelerator Studio, you can even define a custom time frame:

- Select **Custom interval** from the **Show** drop-down list to open the **Define Custom Interval** window.
 - To use a predefined time frame (same as using the **Show** drop-down list in the **Replication Events** window), leave the **Show events within** radio button as is, and select a suitable time frame from the adjacent drop-down list.
 - To define a custom time frame, select **Show events** and:
 - In the line starting with **From**, select the start of your time frame by using the date picker and the time spin buttons on the right.
 - In the line starting with **To**, select the end of your time frame by using the date picker and the time spin buttons on the right.
 - Click **OK** to return to the **Replication Events** window.
- IBM Db2 Analytics Accelerator Studio only:** Typing a search term in the search field on the top of the table reduces the messages being displayed to those messages that contain the search term. For example, if you know the error code belonging to a particular message, you can type in this error code to show just the messages for one particular type of error.
 - To close the **Replication Events** viewer:

| | |
|--------------------------------------|--|
| IBM Db2 Analytics Accelerator Studio | Click the cross-shaped icon on the window tab. |
| IBM Data Server Manager | Click Close . |

Related tasks

[Clearing trace information and replication events](#)

The **Clear** function deletes the collected trace information and the replication events (information about incremental updates) from the replication event log.

Warnings related to incremental updates

The following warnings might occur in connection with incremental updates.

InsufficientLockModeWarning

This warning is issued if you did not select the option **Lock Db2 tables while loading** for the initial load of an accelerator-shadow table taking part in the incremental update process, or if you selected the lock modes **NONE** or **PARTITION**.

If locks were disabled for the initial load of an accelerator-shadow table (**Lock Db2 tables while loading** not selected), the following message is displayed:

```
One of the tables has replication enabled. This table must be locked while loading to avoid an inconsistency of data between Db2 and the accelerator.
```

If the lock modes **NONE** or **PARTITION** were used, data consistency between tables in Db2 and accelerator-shadow tables cannot be guaranteed because table changes can be applied to the Db2 tables during the unload process. If possible, use the lock mode **TABLE_SET**.

NoUniqueConstraintsDefinedWarning

A table does not have a unique constraint, such as a unique key or unique index. This might result in a poor performance when UPDATE or DELETE changes are propagated to an accelerator-shadow table (because it takes longer to identify the changed table rows).



Attention: A risk of data loss also exists because the absence of a unique constraint might cause the deletion of multiple rows from an accelerator-shadow table if just a single row is deleted from a Db2 table. That is, all rows with identical values will be deleted from

the accelerator-shadow table because the various instances cannot be uniquely identified. Incorrect query results will be the consequence. Therefore, do not include such tables in incremental update processes unless you know for sure that the tables do not contain duplicate rows.

OrganizingKeysAndUniqueConstraintsMismatchWarning

The unique constraints of a table in Db2 for z/OS differ from those of the corresponding accelerator-shadow table or exceed the number of matching organizing keys. This might lead to a slow propagation of data changes to the accelerator. In the case of different unique constraints, it just takes longer to identify the table rows to be updated or deleted. A mismatch between the unique constraints of the table and the organizing keys affects the change propagation negatively if there are more unique constraints than matching organizing keys. If extents cannot be located for certain table rows because there is no matching organizing key, table scans take longer.

Collecting CDC trace information

None of the options in the **Save Trace** window of IBM Db2 Analytics Accelerator Studio collects trace information about the CDC Capture Agent. This information, however, might be the key to a problem with the incremental update function.

About this task

If you are facing a problem with the incremental update function, provide as much information about the related software components as possible the support team. This includes information about the CDC Capture Agent, which is the part of IBM InfoSphere Change Data Capture for z/OS that runs on z/OS. The support team might even ask you for this type of information. Here is a description on how to obtain it.

Procedure

1. The CDC Capture Agent is just one of the started tasks running on your z/OS system. If you do not know the name of the started task, ask a z/OS systems programmer which task that is.
2. In the SDSF program on z/OS, type XDC in front of the relevant address space output to copy its contents to a sequential data set.
3. Transfer this data set in ASCII mode to your Linux or Windows workstation and add the resulting txt file to your support case.
4. If a trace dump has been generated, include that information as well. Transfer this data in TERSED format to your workstation because this retains the mainframe-readable formatting of the data during the transfer to a non-mainframe system, and thus ensures that the data remains useful for IBM support. Use an extension of `trts` for the files.

The TERSED format also reduces the file size. See the documentation for the AMATERSE program if you need further assistance.

Related tasks

Configuring the trace behavior

IBM Db2 Analytics Accelerator for z/OS provides trace profiles. These profiles consist of lists of components and events that result in the collection of trace information. In addition, they determine the verbosity level of the information, that is, how detailed the trace information will be. Profiles are available for accelerators as well as for stored procedures. In IBM Db2 Analytics Accelerator Studio, you can also use custom profiles that have been saved to an XML file.

Saving trace information

The **Save Trace** function saves the collected trace information. In the **Save Trace** window, which opens before the action is completed, you can specify or change the settings for the save operation.

Configuring the FTP server for the Save Trace function

To add trace information to an existing IBM support case, your IBM Db2 Analytics Accelerator Studio client must connect to the IBM RETAIN server on which the support case was created.

Clearing trace information and replication events

The **Clear** function deletes the collected trace information and the replication events (information about incremental updates) from the replication event log.

What to do after changing a table or table space in Db2 for z/OS

In a number of cases, an ALTER TABLE or ALTER TABLESPACE statement in Db2 for z/OS does not involve maintenance work on your accelerator-shadow tables. There are cases, however, in which it does. See which steps you might have to take.

NOT Programming Interface information

ALTER TABLE

- **For users of the incremental update function only:** You need not take action after an ALTER TABLE ROTATE PARTITION operation. The CDC Capture Agent automatically detects a rotation in the Db2 transaction log. If a partition has been rotated, the agent generates a DELETE DML statement for the records in the to-be-deleted partition (rolled-off partition). It will also propagate new records that were inserted into the rolled-on partition. So there is no need for a removal, redefinition, re-enablement, or reload of the related accelerator-shadow table.
- If a column was added, changed, or deleted by an ALTER TABLE operation on a Db2 table, queries against this table are not accelerated if they reference the new, changed, or deleted column (reason code 14). This is independent of any incremental update configuration that might exist. Therefore, you must complete the following steps after an ALTER TABLE operation:
 1. Remove the corresponding accelerator-shadow table from all accelerators on which it is defined.

In most cases, a REORG operation is not required before the table can be redefined on the accelerator. However, a REORG is required in the following cases, although this seems to be just a recommended action, as the advisory *REORG-pending* (AREO) state suggests:

 - The ALTER TABLE operation added column.
 - The ALTER TABLE operation changed column data types.
 - The ALTER TABLE operation dropped columns in *Db2 11 for z/OS*.
 2. Redefine the table on the accelerators from which you previously removed it.
 3. If the incremental update function is used, enable incremental updates for the redefined table on all accelerators.
 4. Load the redefined table on all accelerators.
 5. Enable query acceleration for the redefined table on all accelerators.

ALTER TABLESPACE

If a table space was changed in Db2 for z/OS (ALTER TABLESPACE), and the tables of that table space also exist on an accelerator, actions are required under the following conditions:

- If the maximum number of partitions has changed (MAXPARTITIONS), you only have to reload the new or changed partitions. It is not required to reload existing partitions that have not changed.
- If a table space was changed from *segmented* to *partitioned by growth*, you must remove the accelerator-shadow tables of that table space from all accelerators, then redefine and re-prepare these for accelerated queries or incremental updates. Follow steps [“1” on page 187](#) through [“5” on page 187](#) to do that.

End of NOT Programming Interface information

Freeing up storage in Db2 for z/OS

The High Performance Storage Saver archives data of table partitions in Db2 for z/OS to an accelerator. In moving data that is no longer actively used (historical data) to a less expensive storage device, you can free up costly storage space on your database server.

Details

The High Performance Storage Saver is a fully integrated function. Its use has the positive side-effect that it also makes the database system more responsive. This is because fewer objects need to be maintained in the catalog, smaller or fewer indexes need to be searched, reorganizations become quicker, report data and statistics can be gathered faster.

If a query could be accelerated while the original data resided in Db2, it can also be accelerated when the data has been archived to an accelerator.

Just like before, the query routing process is handled by the Db2 query optimizer and IBM Db2 Analytics Accelerator. If data has been archived to an accelerator, and an incoming query needs to access this data, and if furthermore the query qualifies for acceleration, then the query is automatically processed by IBM Db2 Analytics Accelerator.

You can determine whether archived data is to be included in queries. By default, this type of data is excluded, and IBM Db2 Analytics Accelerator for z/OS automatically skips archived records when it processes a query. This often leads to different results for queries that are run repeatedly because the query is run just against the remaining Db2 data. If this behavior is not wanted, you can set the `CURRENT GET_ACCEL_ARCHIVE` special register or the `GET_ACCEL_ARCHIVE` configuration parameter to YES.

You can reload accelerator tables without thinking about archived partitions. Partitions that have been archived are automatically excluded from the load process.

The High Performance Storage Saver is flexible. It is still possible to define one and the same query table on multiple accelerators. It is also possible to archive the data of one or more partitions to an accelerator, while the data of other partitions remains in Db2 for z/OS and on the same or other accelerators.

Before any data is moved to an accelerator and deleted from Db2, image copies are created, which allow you to restore the data if needed. The table spaces of the affected (archived) partitions are set to a persistent read-only state, which prevents future INSERT, UPDATE, and DELETE operations on these partitions. Furthermore, the High Performance Storage Saver ensures that the data in the image copies is consistent with the data that is going to be archived.

The table space of an archived partition continues to exist. It will be empty, but will still claim as much disk space as defined by the *minimum primary space allocation*. To meet your space-saving goal, check the minimum primary space allocation (PRIQTY) for the table spaces of the partitions that you want to archive. Decrease the value if needed by submitting an appropriate `ALTER TABLESPACE . . . PRIQTY` statement.

Restrictions

The following restrictions exist in connection with the High Performance Storage Saver:

- The High Performance Storage Saver works on range-partitioned tables only. If the partitioning is controlled by an index, the index must (already) exist.
- The smallest unit that you can archive is a partition. That is, all the table rows in specified partitions are copied to the accelerator and are finally removed from Db2.
- You can only archive partitions of tables that exist as accelerator-shadow tables and that are in *InitialLoadPending* or *Loaded* state. This implies that partitions cannot be archived if incremental updates have been enabled for the table.
- Table data cannot be archived if a column in the table serves as the parent in a foreign-key-relationship. The reason for this is that the original data is deleted at the end of the archiving process, which removes the values of the foreign key. This cannot be permitted because it violates a fundamental rule for data integrity in a relational database.

- Normally, you cannot rotate a Db2 partition or change partition boundaries if the data of this partition data has been archived to an accelerator. Commands to rotate a partition or change partition boundaries will be rejected by Db2 for z/OS. This restriction can be circumvented by first removing the Partition Read-Only (PRO) state with the help of the Db2 REPAIR utility. If you rotate a partition after removing the PRO state, you are still able to recover the archived partitions by using the image copies, except for those partitions that have been "rotated out". If you change the partition boundaries, on the other hand, the image copies become unusable and the data cannot be restored. You will also end up with orphaned data on the accelerator.



Attention: A rotation leads to the deletion of the data in those Db2 partitions that have been "rotated out". In addition, the corresponding image copies, which were created when the data was archived, will become unusable. The first archiving operation on the table that used to contain the "rotated -out" partitions will also delete the data of the "rotated-out" partitions from the accelerator, irrespective of the partitions that you specified for archiving.

- Starting with product version 4.1 PTF-3, you can archive partitions that contain *Db2 archive tables*. However, you cannot archive *Db2 archive-enabled tables*. Do not confuse these tables with partitions and tables that were archived to an accelerator by the High Performance Storage Saver (accelerator-archive tables). If necessary, check the Db2 documentation for definitions of the terms *Db2 archive table* and *Db2 archive-enabled table*. Bear in mind also that when a Db2 archive table has been processed by the High Performance Storage Saver, you can no longer shift rows from the corresponding Db2 archive-enabled table to the Db2 archive table or vice versa. A message with SQLCODE=-904 is returned when you try to do that.
- No failback mechanism is in place in case an error occurs. Records that have already been archived are not rolled back. The Db2 catalog explicitly marks the partitions containing these records as "archived".
- Columns that cannot be loaded into accelerator tables because their data types are not supported can also not be archived. These are basically the following data types:
 - DECFLOAT
 - TIMESTAMP(*n*) where *n* has a value other than 6.
 - ROWID
 - User-defined types that are based on the above

However, an attempt results in the issuing of a warning. The rest of the partition or table data will be archived. Although the original data is deleted after archiving, the data in unsupported columns is not lost because it is saved to the image copies.

The following data types, on the contrary, lead to a failure of the archiving operation:

- BLOB
- CLOB
- DBCLOB
- XML
- If the GET_ACCEL_ARCHIVE special register (or ZPARM) has been set to the value YES, and a query addresses tables whose data has been archived to different accelerators, the query fails.
- For an archiving operation to succeed, a shared lock is required on the involved tables or partitions. Long-running transactions, such as database queries, might prevent the lock from being obtained. Make sure that long-running transactions are finished before you start archiving.

Archiving partition or table data with the High-Performance Storage Saver

The functionality of the High Performance Storage Saver is fully integrated into your administration client. See how to archive the data of partitions or entire tables from the **Accelerator** view.

Before you begin

1. Make sure that you have read the introduction to the High Performance Storage Saver and the list of restrictions in the superordinate topic.
2. For the creation of the image copies, the AQTENV data set must be referenced by the Workload Manager (WLM) environment that has been set up for the IBM Db2 Analytics Accelerator for z/OS stored procedures, and a user with sufficient access rights must have set at least one of the following environment variables in this data set (a z/OS systems programmer or database administrator usually has the required access rights):

- AQT_ARCHIVE_COPY1
- AQT_ARCHIVE_COPY2
- AQT_ARCHIVE_RECOVERYCOPY1
- AQT_ARCHIVE_RECOVERYCOPY2

These variables determine how many local image copies and recovery image copies are created for each archived partition and how the data sets are named. If you set a variable, a corresponding data set is created when partition data is archived. At least one of the variables must be set. Default values do not exist. Each value is a template specification as used in the Db2 TEMPLATE utility, for example:

```
AQT_ARCHIVE_COPY1 = &USERID..&DB..&TS..P&PART..&UNIQ.
```

where

&USERID.

ID of the user who runs SYSPROC.ACCEL_ARCHIVE_TABLES

&DB.

Name of the database that a partition resides in

&TS.

Name of the table space that the partition resides in

&PART.

Identifier of the (physical) partition. The letter P in the example is a text or string constant used as a prefix. This is required because &PART. resolves to a numeric value like 00001, and this not valid for qualifiers in a data-set name.

&UNIQ.

Causes the creation of a unique identifier

The template specification in the example could, for instance, result in the following image copy name:

```
BCKE.V4L1.BCKERTSE.CK RANGE3.P00001.D72R4KHN
```

- All template variables that are documented for the Db2 COPY utility can be used, with the exception of &SEQ (&SQ), &LIST (&LI), and &DSNUM.
- The chosen variables must ensure the uniqueness of image-copy data-set names. It is therefore recommended that you use at least the &PART. and &UNIQ. template variables.
- Templates must resolve to valid z/OS data set names.
- The template data-set names that you use must have been mapped to suitable data classes in the DFSMS.

Important: The AQT_ARCHIVECOPY_HLQ environment variable that was used with earlier versions of the High Performance Storage Saver is deprecated. Remove it from the AQTENV data set.

3. The stored procedure SYSPROC.ACCEL_ARCHIVE_TABLES creates image copies whose size might exceed 65535 tracks on direct access storage devices (DASDs). Therefore, a z/OS systems programmer must define and use a data class in the storage management subsystem (SMS) that supports larger sequential data sets and must associate this data class with the range of template data-set names for image copies. Data set types that can be used to this end are shown in [Table 45 on page 191](#).

| Data-set type | Settings in SMS data class | Properties of data-set type |
|-----------------------------|--|--|
| Extended-format data set | <ul style="list-style-type: none"> • Data Set Name Type = EXT • One of the following extension sub-parameter settings: <ul style="list-style-type: none"> – Ext subparameter = R (required) – Ext subparameter = P (preferred) • Volume Count > 1 | <ul style="list-style-type: none"> • Requires multiple volumes • Maximum volume size still 65535 tracks |
| Large-format data set | Data Set Name Type = LARGE | <ul style="list-style-type: none"> • Multiple volumes possible, but not required • Volume sizes of more than 65535 tracks possible |
| Extended-attribute data set | EATTR = OPT | <ul style="list-style-type: none"> • Data sets must be stored on an extended-address volume (EAV) with at least 65521 cylinders. • Multiple volumes possible, but not required. A single volume might be sufficient. |

To associate a suitable data class with the range of template data-set names, the z/OS systems programmer must create or modify a corresponding automatic class selection routine (ACS routine). The following example shows an excerpt of such an ACS routine, in which it has been assumed that the value of AQT_ARCHIVE_COPY1 starts with IDAAHPSS, as in IDAAHPSS.&USERID.&DB.&TS.&P&PART.&UNIQU.:

```
FILTLIST LARGE INCLUDE(IDAAHPSS.**)  
....  
WHEN (&DSN = &LARGE) DO SET &DATACLAS = 'LARGE' ...
```

Tip: You can also define the ACS routine in such a way that the image copies created by the High Performance Storage Saver are stored on tape devices so that space can be saved on more expensive storage devices.

4. After setting the environment variables mentioned in step “2” on page 190, the Workload Manager (WLM) environment for the SYSPROC.ACCEL_ARCHIVE_TABLES stored procedure must be refreshed. Make sure that this has been done.
5. If you intend to archive partitions from a Db2 data sharing group, make sure that the following conditions apply:
 - a. The volumes or devices for the storage of image copies must be available for all members of the data sharing group.

- b. The values of the environment variables mentioned in step “2” on page 190 must be identical on all members of the data sharing group.
- 6. Non-partitioning indexes might slow down the archiving process. If more than just a few small to mid-sized non-partitioning indexes are defined for a table, but the partitions to be archived are not many and rather large, then consider dropping the indexes before archiving. Re-create the indexes thereafter.
- 7. If you also use the incremental update function, check the setting of the ONUTILITYACTION keyword in the IBM InfoSphere Change Data Capture for z/OS configuration. The setting ONUTILITYACTION=IDLE leads to a conflict because IDLE suspends the propagation of data changes for the entire table, and not just the partitions that have been archived by the High Performance Storage Saver. Hence the parts that have not been archived will not be synchronized anymore. To avoid this conflict, set the keyword to the value IGNORE.

About this task

The archiving task is carried out by the SYSPROC.ACCEL_ARCHIVE_TABLES stored procedure on your data server. For information about the privileges that are required to run this procedure and further details, follow the appropriate **Related reference** link at the end of this topic.

Note: It might take a long time to archive many partitions. If you an administration client to invoke the ACCEL_ARCHIVE_TABLES stored procedure, the administration client must stay open until the task has been completed. Otherwise, the stored procedure aborts, in which case it might be difficult to recover from the errors that were caused by the abortion. To avoid this problem, invoke the stored procedure from a TSO batch job. You can also repeatedly archive a smaller set of partitions at a time. Before you invoke the function, make sure that you have enough disk space for the image copies.

Procedure

1. Start your administration client.
2. Connect to the Db2 subsystem that is associated with the accelerator you want to archive to:

| | |
|--------------------------------------|--|
| IBM Db2 Analytics Accelerator Studio | Double-click the database-connection-profile icon for that subsystem. |
| IBM Data Server Manager | From the drop-down list on the top banner, select the corresponding database connection. |

3. Open the list of accelerators:

| | |
|--------------------------------------|--|
| IBM Db2 Analytics Accelerator Studio | In the Administration Explorer , go to the Accelerators folder. |
| IBM Data Server Manager | <ol style="list-style-type: none"> a. Click  in the upper left. b. Select ADMINISTER > Accelerators. |

4. Select the accelerator you want to archive to:

| | |
|--------------------------------------|---|
| IBM Db2 Analytics Accelerator Studio | In the Object List Editor , double-click the accelerator name. |
| IBM Data Server Manager | <ol style="list-style-type: none"> a. Select the accelerator (row) in the list. b. Click Manage. |

Note: You can only archive partition or table data to a regular accelerator. Therefore, you must open the **Accelerator view** of a regular accelerator.

5. If the tables are not yet defined as accelerator-shadow tables, click **Add** to start the **Add Tables** wizard and define these tables.

6. If necessary, refresh the **Accelerator** view.
7. To archive the data of a range-partitioned table or partitions of this table, expand the appropriate schema node and select the table name.
8. On the toolbar of the **Accelerator** view, select **Storage Saver > Move Partitions to Accelerator**.
9. In the **Move Storage Saver Partitions to Accelerator** window, you can select a partitioning key or individual partitions.
 - To select the partition data to be archived with the help of a partitioning key, leave **Move all partitions up to and including the following limit key** selected and choose the proper key from the drop-down list.

The drop-down list is filled with the values of the LIMITKEY column in the SYSIBM.SYSTABLEPART catalog table. The values are sorted by the LOGICAL_PART column in SYSIBM.SYSTABLEPART and appear in descending order. Mostly, LIMITKEY is a column of the type DATE or DATE/TIME, which allows you to select partitions whose data covers a certain time frame. The key that you use might be different, and so might be the choices in the drop-down list.

- To manually select the partitions whose data you want to archive, click **Manually select partitions** and select the appropriate check boxes in front of the (logical) partition names. The names of partitions whose data has already been archived are grayed out. To select all partitions:

| | |
|--------------------------------------|--|
| IBM Db2 Analytics Accelerator Studio | Click Select all . |
| IBM Data Server Manager | Select the check box in front of the Logical Partition column header. |

To clear all selections:

| | |
|--------------------------------------|---|
| IBM Db2 Analytics Accelerator Studio | Click Deselect all . |
| IBM Data Server Manager | Clear the check box in front of the Logical Partition column header. |

10. Click **OK**.

What to do next

Check with your database operators (the people running queries) whether the archived data needs to be accessed by their queries. Whether to include or exclude the archived data can be controlled by using the **GET_ACCEL_ARCHIVE** parameter (ZPARM) or the SET CURRENT GET_ACCEL_ARCHIVE special register. The parameter or special register can be set to the value YES or NO. If you set it to YES, the archived data will be available for queries.

The **GET_ACCEL_ARCHIVE** parameter is set on the DSN6SPRN panel of a Db2 subsystem. The systems programmer or database administrator needs to enable option 2.

The SET CURRENT GET_ACCEL_ARCHIVE special register can be prepended to the SQL script for a query.

Example: Suppose you have a table called ORDERS, which contains a history of purchase transactions. This table is partitioned by time and contains a partition for each quarter. You keep ten years of history, but only a small subset of the queries accesses older data. Most queries use a range predicate, which restricts the query to data of the current year. You decide to archive all data that was collected in the previous years. For the queries that access the current year's data only, you need not set the SET CURRENT GET_ACCEL_ARCHIVE special register because these queries need not “see” the archived data. They can run on the accelerator or in Db2 for z/OS, depending on the SET CURRENT QUERY ACCELERATION special register. For those queries that need to access older data, you specify SET CURRENT GET_ACCEL_ARCHIVE=YES. For the latter type of queries, you must also set the SET CURRENT QUERY ACCELERATION special register to a value other than NONE. The query cannot run in Db2 for z/OS because Db2 does no longer contain the data.

Related information

[IBM DB2 Analytics Accelerator for z/OS: Stored Procedures Reference](#)

Impact of special register settings

It has been said that a query cannot be accelerated without setting the SET CURRENT QUERY ACCELERATION special register to a value other than NONE. It has also been said that the GET_ACCEL_ARCHIVE or the SET CURRENT GET_ACCEL_ARCHIVE special register determines whether data that was moved with the help of the High Performance Storage Saver is included in a query. The table in this topic explores all combinations of these settings for qualifying and non-qualifying queries and briefly describes the consequences.

If a query can neither be executed in Db2 for z/OS, nor on an accelerator, the following message is displayed, which starts with SQL code -4742:

```
-4742 The statement cannot be executed by Db2 or in the accelerator (REASON <code>)
```

where <code> stands for the numeric reason code. For a list of the reason codes, follow the link at the end of this topic.

| Setting of SET CURRENT QUERY ACCELERATION | Setting of GET_ACCEL_ARCHIVE or SET CURRENT GET_ACCEL_ARCHIVE | Query qualifies for acceleration? | Consequence |
|---|---|-----------------------------------|---|
| NONE | NO | No | The query is executed in Db2. |
| NONE | NO | Yes | The query is executed in Db2. |
| NONE | YES | No | The query fails and SQL code -4742 is returned. |
| NONE | YES | Yes | The query fails and SQL code -4742 is returned. |
| ENABLE | NO | No | The query is executed in Db2. |
| ENABLE | NO | Yes | The query is accelerated. Data of moved tables and partitions is excluded. If the query fails on the accelerator, SQL code -901 is returned to the calling application. |
| ENABLE | YES | No | The query fails and SQL code -4742 is returned. |
| ENABLE | YES | Yes | The query is accelerated. Data of moved tables and partitions is included, provided that this data resides on the accelerator that the query is directed at. If the query fails on the accelerator, SQL code -901 is returned to the calling application. |
| ENABLE WITH FAILBACK | NO | No | The query is executed in Db2. |
| ENABLE WITH FAILBACK | NO | Yes | The query is accelerated. Data of moved tables and partitions is excluded. If the query fails on the accelerator, an attempt is made to run the query in Db2. |
| ENABLE WITH FAILBACK | YES | No | The query fails and SQL code -4742 is returned. |

Table 46. Impact of special register settings on the query execution, taking the query qualification into account (continued)

| Setting of SET CURRENT QUERY ACCELERATION | Setting of GET_ACCEL_ARCHIVE or SET CURRENT GET_ACCEL_ARCHIVE | Query qualifies for acceleration? | Consequence |
|---|---|-----------------------------------|---|
| ENABLE WITH FAILBACK | YES | Yes | The query is accelerated. Data of moved tables and partitions is included, provided that this data resides on the accelerator that the query is directed at. If the query fails, SQL code -4742 is returned. |
| ALL | NO | No | The query fails and SQL code -4742 is returned. |
| ALL | NO | Yes | The query is accelerated. Data of moved tables and partitions is excluded. If the query fails on the accelerator, SQL code -901 is returned to the calling application. |
| ALL | YES | No | The query fails and SQL code -4742 is returned. |
| ALL | YES | Yes | The query is accelerated. Data of moved tables and partitions is included, provided that this data resides on the accelerator that the query is directed at. If the query fails on the accelerator, SQL code -901 is returned to the calling application. |
| ELIGIBLE | NO | No | The query is executed in Db2. |
| ELIGIBLE | NO | Yes | The query is accelerated. Data of moved tables and partitions is excluded. If the query fails on the accelerator, SQL code -901 is returned to the calling application. |
| ELIGIBLE | YES | No | The query fails and SQL code -4742 is returned. |
| ELIGIBLE | YES | Yes | The query is accelerated. Data of moved tables and partitions is included, provided that this data resides on the accelerator that the query is directed at. If the query fails on the accelerator, SQL code -901 is returned to the calling application. |

Important: A query that would be executed in Db2 for z/OS according to the special register or parameter settings in [Table 46 on page 194](#) fails with SQL code -4742 if the query references data that can only be found on the accelerator because it has been moved.

Related concepts

EXPLAIN information

After creating the necessary EXPLAIN tables, you can analyze queries by invoking the Db2 EXPLAIN function. Such queries are accepted by regular and virtual accelerators alike. The analysis shows whether a query can be accelerated, indicates the reason for a failure, and gives a response time estimate. The outcome of the analysis can also be visualized in an access plan graph.

Restoring archived partitions

Restoring archived partition data might become necessary if you must add or update data in the original Db2 partition. It might also become necessary if an error in IBM Db2 Analytics Accelerator for z/OS has led to the loss of archived data. Restoring archived data is required also after changing the schema of a Db2 table (for example, adding a column).

About this task

In the context of archived partition data, the restore operation is typically just a single operation in a series of actions that must be taken. For example, adding a column to a Db2 table involves the following steps:

1. Restoring the archived partitions to Db2
2. Removing the corresponding accelerator-shadow table
3. Making changes to the schema, that is, submitting the ALTER TABLE ADD COLUMN statement
4. Redefining the accelerator-shadow table
5. Archiving the partition data once again

What you need to know about the restore function:

- The restore function uses the last Db2 image copy to recover the data. If that image copy is damaged, the function automatically uses the next image copy in backward chronological order.
- All indexes are rebuilt.
- A CHECK DATA operation is carried out if needed.
- An archived partition is not deleted from the accelerator, but kept as a regular partition for query acceleration.
- All image copies and entries in the Db2 catalog table SYSIBM.SYSCOPY are kept.
- The status information of tables in the ARCHIVE column of the SYSIBM.SYSACCELERATEDTABLES catalog table is restored if no further copies exist on any accelerator. That is, the values 'A' or 'C' are reset to ''.
- If a restore operation fails for some reason, you can resume it if you run the function again on the same table or partitions.
- Depending on the amount of data to be restored, the operation might need several hours to complete.



Attention: Do not sever the connection to the Db2 subsystem during that time.

- If you have archived the same partition more than once on different accelerators, you can run a restore operation for this partition from each of the accelerators. This is not prohibited. However, the Db2 data is not updated anymore after the first restore because the system treats it like an already restored partition. So if the data is different on the accelerators, carefully decide from which accelerator you want to restore first.
- Bear in mind that queries might run longer and might return more copious results after a restore because the formerly archived partitions are no longer excluded from the queries.

The task of restoring partition or table data to Db2 for z/OS is carried out by the SYSPROC.ACCEL_RESTORE_ARCHIVE_TABLES stored procedure on your data server. For information about the privileges that are required to run this procedure and further details, see the corresponding article in the *IBM Db2 Analytics Accelerator for z/OS: Stored Procedures Reference*. You find a link at the end of this topic.

Procedure

1. Start your administration client.
2. Connect to the Db2 subsystem that is associated with the accelerator you want to restore from:

| | |
|--------------------------------------|--|
| IBM Db2 Analytics Accelerator Studio | Double-click the database-connection-profile icon for that subsystem. |
| IBM Data Server Manager | From the drop-down list on the top banner, select the corresponding database connection. |

3. Open the list of accelerators:

| | |
|--------------------------------------|---|
| IBM Db2 Analytics Accelerator Studio | In the Administration Explorer , go to the Accelerators folder. |
| IBM Data Server Manager | a. Click  in the upper left. b. Select ADMINISTER > Accelerators . |

4. Select the accelerator you want to restore from:

| | |
|--------------------------------------|--|
| IBM Db2 Analytics Accelerator Studio | In the Object List Editor , double-click the accelerator name. |
| IBM Data Server Manager | a. Select the accelerator (row) in the list. b. Click Manage . |

5. Check whether the tables that the partitions belong to have been enabled for incremental updates. If so, disable incremental updates.

You might come across this situation if just a subset of all the partitions of a table was archived. If unarchived partitions remain on the accelerator, the relevant table can be enabled for incremental updates. However, a restore operation fails if this has been done.

6. If necessary, refresh the view.

7. On the toolbar, select **Storage Saver > Restore Partitions to Db2**.

8. In the **Restore Storage Saver Partitions to Db2** window, you can select tables and partitions to be restored.

Select the check box in front of a table name to restore the data of an entire table (all partitions). Select the appropriate check boxes in front of (logical) partition names to restore just the data of the selected partitions. To select all tables and partitions that can be restored:

| | |
|--------------------------------------|--|
| IBM Db2 Analytics Accelerator Studio | Click Select all . |
| IBM Data Server Manager | Select the check box in front of the Logical Partition column header. |

To clear all selections:

| | |
|--------------------------------------|---|
| IBM Db2 Analytics Accelerator Studio | Click Deselect all . |
| IBM Data Server Manager | Clear the check box in front of the Logical Partition column header. |

When you highlight a partition name, the **Image copies** section displays the names of the image copies (data set names) that will be used to restore the partition.

9. Click **OK**.

What to do next

The recovery of partitions invalidates the statistics in the SYSIBM.SYSTABLESPACESTATS catalog table. This leads to a situation in which table metrics, such as the partition size, are not reported anymore. To avoid this, run the following Db2 command to refresh the statistics in the catalog table:

```
RUNSTATS TABLESPACE <database-name>.<table-space name> SHRLEVEL REFERENCE
```

where <database-name> is the name of the database and <table-space name> is the name of the table space.

Note: This step might take several hours to complete. If you plan to archive the partition data again shortly, you can omit it.

Related information

[IBM DB2 Analytics Accelerator for z/OS: Stored Procedures Reference](#)

How to handle the RBA and LRSN conversion in Db2 11 for z/OS

In Db2 11 for z/OS, the relative byte address (RBA) and the log record sequence number (LRSN) were changed from a 6-byte format to a 10-byte format. This has implications if you have archived partition data with the High Performance Storage Saver. In Db2, the migration from the old format to the new requires a REORG operation. However, the empty partitions that remain after archiving cannot be reorganized because they were set to persistent read-only (PRO) state.

To maintain the compatibility of archived tables and partitions, follow the series of steps in the following table that best suits your needs:

| | |
|--|--|
| <ol style="list-style-type: none">1. Remove the PRO state with the help of the Db2 REPAIR utility.2. Run the REORG operation.3. Reset the PRO state. <p>This is the recommended solution. It saves you a lot of time because you avoid to restore data. Note that you can restore the data at a later time into already converted tables and partitions even if the image copies were taken before the RBA and LRSN conversion. A further REORG operation will be needed after that.</p> | <ol style="list-style-type: none">1. Restore the data of the archived tables and partitions from the existing image copies.2. Run the REORG operation.3. Archive the data again with the High Performance Storage Saver. <p>If you do not want a coexistence of data in different RBA and LRSN formats, then this solution is to be preferred. Bear in mind that this will occupy system resources for a much longer time.</p> |
|--|--|

Federated access

The term *federated access* or *federation* describes the ability to run accelerated queries against tables that do not belong to or originate from the Db2 subsystem that issues the query.

Normally, you can only accelerate queries if a Db2 subsystem is paired with an accelerator and if the tables to be queried exist in that Db2 subsystem. This can be regarded as a security feature; a second Db2 subsystem paired with the same accelerator cannot access tables in the first Db2 subsystem and vice versa.

However, there are situations in which one would like to lift this restriction: Db2 subsystems are often organized alongside geographical boundaries, temporal boundaries, or areas of business.

Geographical boundaries translate into a segmentation of the table data by region. For example, a company does business in the U.S. and in Asia; the tables in subsystem A contain the sales figures for the U.S.; the tables in subsystem B the sales figures for Asia.

If data is temporally segmented, the tables in each subsystem cover different time spans. For example, the tables in subsystem A contain the data related to recent business activities, reaching three months

from the present time into the past. Db2 subsystem B, on the other hand, contains business data that is older than three months.

If data is segmented by areas of business, the organization of the database follows a company's key business areas or its product portfolio. Assume that an organization runs a chain of gas stations and also produces cosmetics (both business areas are based on oil). Subsystem A contains the data of the gas station business; subsystem B the data of the cosmetics business.

Frequently, the aim of analytical queries is to capture trends across regions, time lines, or business areas. In accordance with the previous examples, one would like to find out how the business in the U.S. develops against the business in Asia. How do recent sales figures compare with those of the past? What are the growth rates in the gas station business as opposed to those in the cosmetics sector?

Queries that answer these question require access to different data sources. If the data is segmented by the organization of the database, access must be extended to tables in other Db2 subsystems, and this is what the *federated access* feature is about.

An access extension to tables in a Db2 subsystem is achieved through the following steps:

1. A user with sufficient rights on the Db2 subsystem that owns the tables (remote Db2 subsystem) grants the right to access a set of tables to a Db2 subsystem that normally cannot access these tables (called the referencing Db2 subsystem).
2. A user with sufficient rights on the referencing subsystem runs a command to create reference tables. These reference tables contain metadata and pointers to accelerator-shadow tables on the accelerator. They are implemented as accelerator-only tables on the shared accelerator, with corresponding entries in the catalog of the referencing Db2 subsystem.
3. Queries from the referencing Db2 subsystem can now access these referencing accelerator-only tables.

See the following figure:

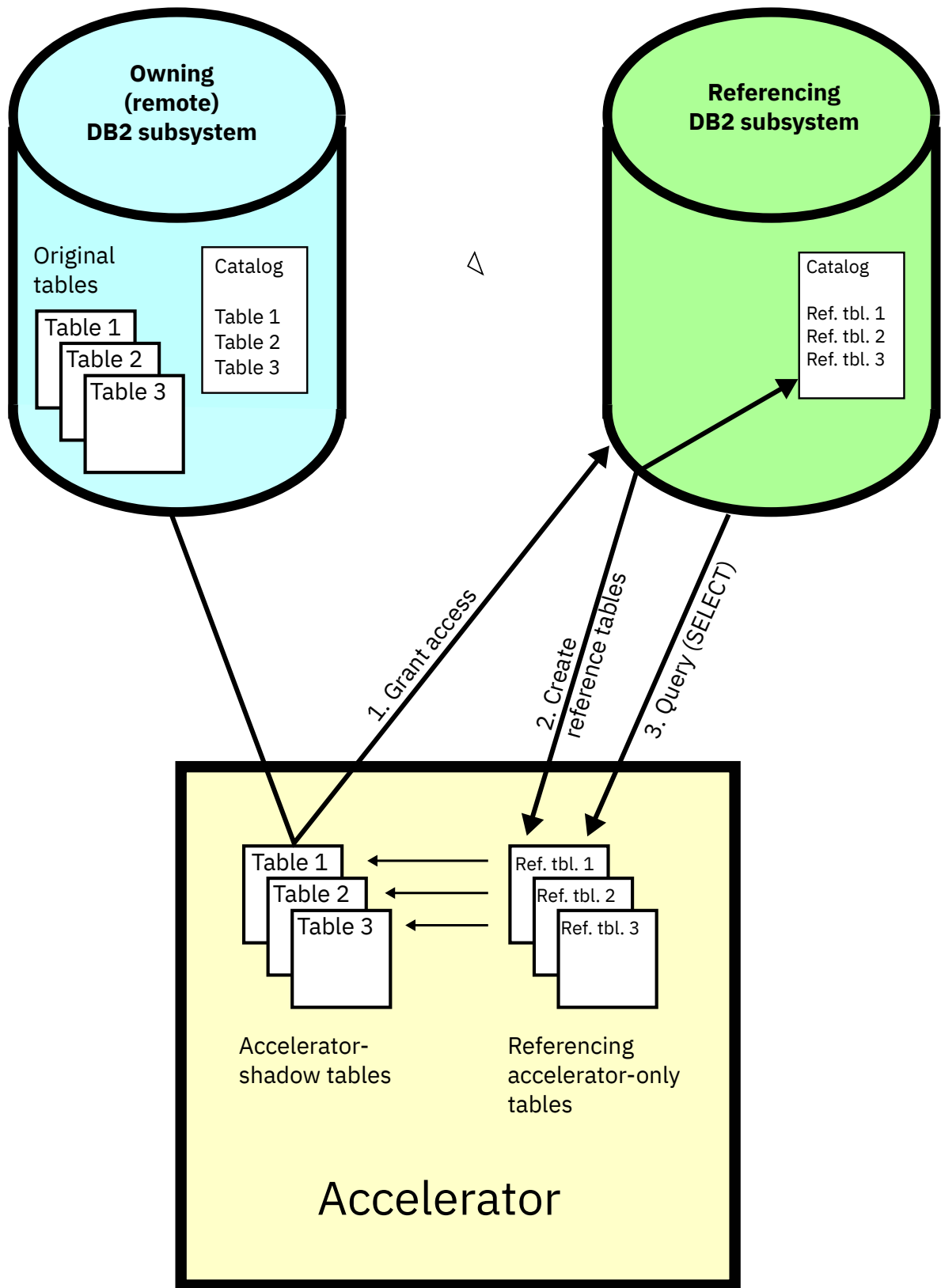

Figure 19. Federated access diagram

It is possible for the administrator of the owning Db2 subsystem to revoke the access privileges at any time.

It is also possible (for the administrator of the referencing Db2 subsystem) to remove the reference tables. This is mostly done when the data in these tables has become obsolete. To obtain results on more recent data, the administrator might want to delete the existing reference tables and create new ones.

Granting access to remote tables

As an administrator or user with sufficient access rights on a Db2 subsystem, you can grant the right to access tables in the subsystem to another (referencing Db2 subsystem). The granted permission includes the right to create reference tables from the referencing Db2 subsystem.

Before you begin

- The owning (remote) Db2 subsystem and the referencing Db2 subsystem must share (be paired with) a common accelerator.
- Database connections must exist for both Db2 subsystems.
- Your user ID needs the required authorizations to run the SYSPROC.ACCEL_GRANT_TABLES_REFERENCE stored procedure on the owning (remote) Db2 subsystem.

Procedure

1. Connect to the owning (remote) Db2 subsystem:

| | |
|--------------------------------------|--|
| IBM Db2 Analytics Accelerator Studio | Double-click the database-connection-profile icon for that subsystem. |
| IBM Data Server Manager | From the drop-down list on the top banner, select the corresponding database connection. |

2. Select the accelerator that is paired with the owning (remote) Db2 subsystem:

| | |
|--------------------------------------|---|
| IBM Db2 Analytics Accelerator Studio | <ol style="list-style-type: none"> a. In the Administration Explorer, select the Accelerators folder. b. In the Object List Editor, double-click an accelerator name to open the corresponding Accelerator view. |
| IBM Data Server Manager | <ol style="list-style-type: none"> a. Click  in the upper left. b. Select ADMINISTER > Accelerators. c. In the list of accelerators, select the name of the accelerator (row). |

3. Display the list of tables on that accelerator:

Mind that although the referencing Db2 subsystem is paired with the same accelerator, it will use a different accelerator view, which will show a different list of tables. Make sure that you select the view which will display the tables in the owning Db2 subsystem.

| | |
|--------------------------------------|---|
| IBM Db2 Analytics Accelerator Studio | Scroll down to the Tables section. |
| IBM Data Server Manager | Click Manage . |

4. Grant access to the tables on that accelerator:

| | |
|--------------------------------------|--|
| IBM Db2 Analytics Accelerator Studio | <p>a. From the toolbar above the list of tables, select Federation > Grant Access.</p> <p>b. In the Db2 Tables window, select the tables that you want to give access to, that is, accelerator-shadow tables or ordinary, that is, not referencing accelerator-only tables in the owning (remote) Db2 subsystem.</p> <p>c. Click Next.</p> |
| IBM Data Server Manager | <p>a. Select Federation > Grant.</p> <p>b. In the selection box labeled Db2 Tables, select the tables that you want to give access to, that is, accelerator-shadow tables or ordinary, that is, not referencing accelerator-only tables in the owning (remote) Db2 subsystem.</p> |

5. Select the Db2 subsystems that are supposed to have access to the selected tables. In the window or selection box that is labeled **Db2 Subsystems**, you see a list of the Db2 subsystems that are connected to the same accelerator. Select one or more referencing Db2 subsystems, that is, subsystems that should have access to the selected tables.
6. Confirm:

| | |
|--------------------------------------|-----------------------|
| IBM Db2 Analytics Accelerator Studio | Click Finish . |
| IBM Data Server Manager | Click OK . |

Results

The administrator of the referencing Db2 subsystem can now create reference tables for the tables that she or he has been given access to.

Creating reference tables

Running the **Create Reference Tables** function you administration client, you create accelerator-only tables that contain metadata and pointers to accelerator-shadow tables on the shared accelerator, provided that access to these tables has been granted before.

Before you begin

- The owning (remote) Db2 subsystem and the referencing Db2 subsystem must share (be paired with) a common accelerator.
- Database connection profiles must exist for both Db2 subsystems.
- Your user ID needs the required authorizations to run the SYSPROC.ACCEL_CREATE_REFERENCE_TABLES stored procedure on the referencing Db2 subsystems.

About this task

The reference tables are used when a query from a referencing Db2 subsystem includes the names of tables on the remote Db2 subsystem. The query thus goes against the reference tables. The metadata and pointers in the reference tables ensure that the right data in the accelerator-shadow tables or the (regular) accelerator-only tables is queried. The accelerator-shadow tables or accelerator-only tables that actually contain the data are the result of **Add Tables** and **Load Tables** operations from the owning or remote Db2 subsystem.

Procedure

1. Connect to the referencing Db2 subsystem:

| | |
|--------------------------------------|--|
| IBM Db2 Analytics Accelerator Studio | Double-click the database-connection-profile icon for that subsystem. |
| IBM Data Server Manager | From the drop-down list on the top banner, select the corresponding database connection. |

2. Select the accelerator that is paired with the referencing Db2 subsystem:

| | |
|--------------------------------------|---|
| IBM Db2 Analytics Accelerator Studio | <ol style="list-style-type: none"> a. In the Administration Explorer, select the Accelerators folder. b. In the Object List Editor, double-click an accelerator name to open the corresponding Accelerator view. |
| IBM Data Server Manager | <ol style="list-style-type: none"> a. Click  in the upper left. b. Select ADMINISTER > Accelerators. c. In the list of accelerators, select the name of the accelerator (row). |

3. Display the list of tables on that accelerator:

| | |
|--------------------------------------|---|
| IBM Db2 Analytics Accelerator Studio | Scroll down to the Tables section. |
| IBM Data Server Manager | Click Manage . |

4. Start creating the references:

| | |
|--------------------------------------|--|
| IBM Db2 Analytics Accelerator Studio | <ol style="list-style-type: none"> a. On the toolbar of the Tables section, select Federation > Create Reference Tables. b. In the Db2 Subsystems window, you see a list of Db2 subsystems that qualify as referencing Db2 subsystems, that is, subsystems that will query the remote tables. Select one or more of these subsystems. c. Click Next. |
| IBM Data Server Manager | <ol style="list-style-type: none"> a. Select Federation > Create Reference. b. In the selection box labeled Db2 Subsystems, you see a list of Db2 subsystems that qualify as referencing Db2 subsystems, that is, subsystems that will query the remote tables. Select one or more of these subsystems. |

5. Select the tables that you want to create reference tables for:

| | |
|--------------------------------------|---|
| IBM Db2 Analytics Accelerator Studio | In the Db2 Tables window, you see a list of tables on the accelerator. Select the tables for which you want to create reference tables by selecting the appropriate check boxes. To select all tables that belong to a schema, select the check box in front of the schema name. |
|--------------------------------------|---|

| | |
|-------------------------|---|
| | <p>If the list is long, first narrow the choice by using the Name like filter field. Type the names of schemas or tables in this field, either fully or partially, to display just schemas and tables bearing or starting with that name. The names of tables that have already been selected are grayed out.</p> <p>To the right of the Name like field, you also find controls (icons) to do the following:</p> <ol style="list-style-type: none"> Select or deselect all tables Expand or collapse all schemas |
| IBM Data Server Manager | <p>In the selection box labeled Db2 Tables, select the tables for which you want to create reference tables by selecting the appropriate check boxes. To select all tables in the selection box, select the check box in front of the NAME column header.</p> <p>You can use a filter to limit the number of tables in the selection box:</p> <ol style="list-style-type: none"> Click  to display the search field. Type the names of tables in the search field, either fully or partially, to display just tables containing your search string. The names of tables that have already been selected are grayed out. |

6. Optional: Select the check box to complete the required grant step and create the reference tables in one go:

| | |
|--------------------------------------|---|
| IBM Db2 Analytics Accelerator Studio | Select Grant access before creating reference tables |
| IBM Data Server Manager | Select Check here to enable a Grant stored procedure call before Create Reference. |

Note: Selecting this check box has an effect only if your user ID has the authorization to run the SYSPROC.ACCEL_GRANT_TABLES_REFERENCE stored procedure on the owning (remote) Db2 subsystem.

7. Confirm:

| | |
|--------------------------------------|----------------------|
| IBM Db2 Analytics Accelerator Studio | Click Finish. |
| IBM Data Server Manager | Click OK. |

Results

Reference tables for the selected tables are created on the shared accelerator and corresponding entries are written to the catalog of the referencing Db2 subsystem. The new tables can be queried from the referencing Db2 subsystem.

Revoking table access

Run the **Revoke Access** or **Revoke** function to withdraw the right to access remote tables from a referencing Db2 subsystem.

Before you begin

- The owning (remote) Db2 subsystem and the referencing Db2 subsystem must share (be paired with) a common accelerator.
- Database connection profiles must exist for both Db2 subsystems.
- Your user ID needs the required authorizations to run the SYSPROC.ACCEL_REVOKE_TABLES_REFERENCE stored procedures on the owning (remote) Db2 subsystem.

Procedure

1. Connect to the owning (remote) Db2 subsystem:

| | |
|--------------------------------------|--|
| IBM Db2 Analytics Accelerator Studio | Double-click the database-connection-profile icon for that subsystem. |
| IBM Data Server Manager | From the drop-down list on the top banner, select the corresponding database connection. |

2. Select the accelerator that is paired with the owning (remote) Db2 subsystem:

| | |
|--------------------------------------|---|
| IBM Db2 Analytics Accelerator Studio | <ol style="list-style-type: none"> a. In the Administration Explorer, select the Accelerators folder. b. In the Object List Editor, double-click an accelerator name to open the corresponding Accelerator view. |
| IBM Data Server Manager | <ol style="list-style-type: none"> a. Click  in the upper left. b. Select ADMINISTER > Accelerators. c. In the list of accelerators, select the name of the accelerator (row). |

3. Display the list of tables on that accelerator:

Mind that although the referencing Db2 subsystem is paired with the same accelerator, it will use a different accelerator view, which will show a different list of tables. Make sure that you select the view which will display the tables in the owning Db2 subsystem.

| | |
|--------------------------------------|---|
| IBM Db2 Analytics Accelerator Studio | Scroll down to the Tables section. |
| IBM Data Server Manager | Click Manage . |

4. Revoke access to tables in the owning Db2 subsystem by referencing Db2 subsystems:

| | |
|--------------------------------------|---|
| IBM Db2 Analytics Accelerator Studio | <ol style="list-style-type: none"> a. From the toolbar above the list of tables, select Federation > Revoke Access. b. In the Db2 Subsystems window, you see a list of the Db2 subsystems that are paired with the same accelerator. Select one or more referencing Db2 subsystems that should no longer be allowed to access certain remote tables in the owning Db2 subsystem. You |
|--------------------------------------|---|

| | |
|-------------------------|---|
| | <p>select these tables in step “Revoking table access” on page 205.</p> <p>c. Click Next.</p> <p>d. In the Db2 Tables window, select the tables that the previously selected Db2 subsystems should be denied access to. Select by clicking the appropriate check boxes. To select all tables that belong to a schema, select the check box in front of the schema name.</p> <p>If the list is long, first narrow the choice by using the Name like filter field. Type the names of schemas or tables in this field, either fully or partially, to display just schemas and tables bearing or starting with that name. The names of tables that have already been selected are grayed out.</p> <p>To the right of the Name like field, you also find controls (icons) to do the following:</p> <p>a. Select or deselect all tables</p> <p>b. Expand or collapse all schemas</p> |
| IBM Data Server Manager | <p>a. Select Federation > Revoke.</p> <p>b. Select the Db2 subsystems that are supposed to have access to the selected tables.</p> <p>c. In the selection box labeled Db2 Subsystems, select one or more referencing Db2 subsystems that should no longer access certain remote tables in the owning Db2 subsystem. You select these tables in the next step.</p> <p>d. In the selection box labeled Db2 Tables, select the tables that the previously selected Db2 subsystems should be denied access to. Select by clicking the appropriate check boxes. To select all tables that belong to a schema, select the check box in front of the schema name.</p> <p>You can use a filter to limit the number of tables in the selection box:</p> <p>a. Click  to display the search field.</p> <p>b. Type the names of tables in the search field, either fully or partially, to display just tables containing your search string. The names of tables that have already been selected are grayed out.</p> |

5. Confirm:

| | |
|--------------------------------------|-----------------------|
| IBM Db2 Analytics Accelerator Studio | Click Finish . |
| IBM Data Server Manager | Click OK . |

Results

Access rights to the selected tables are revoked. Even though the corresponding reference tables are not deleted, the referencing Db2 subsystem can no longer query the tables that the reference tables point to. Attempts will be answered with an authorization error.

Removing reference tables

Run the **Remove Reference Tables** or **Remove Reference** function to delete reference tables (referencing accelerator-only tables) from an accelerator.

Before you begin

- The owning (remote) Db2 subsystem and the referencing Db2 subsystem must share (be paired with) a common accelerator.
- Database connection profiles must exist for both Db2 subsystems.
- Your user ID needs the required authorizations to run the SYSPROC.ACCEL_REMOVE_REFERENCE_TABLES stored procedure on the referencing Db2 subsystem.

Procedure

1. Connect to the referencing Db2 subsystem:

| | |
|--------------------------------------|--|
| IBM Db2 Analytics Accelerator Studio | Double-click the database-connection-profile icon for that subsystem. |
| IBM Data Server Manager | From the drop-down list on the top banner, select the corresponding database connection. |

2. Select the accelerator that is paired with the referencing Db2 subsystem:

| | |
|--------------------------------------|---|
| IBM Db2 Analytics Accelerator Studio | <ol style="list-style-type: none">a. In the Administration Explorer, select the Accelerators folder.b. In the Object List Editor, double-click an accelerator name to open the corresponding Accelerator view. |
| IBM Data Server Manager | <ol style="list-style-type: none">a. Click  in the upper left.b. Select ADMINISTER > Accelerators.c. In the list of accelerators, select the name of the accelerator (row). |

3. Display the list of tables on that accelerator:

| | |
|--------------------------------------|---|
| IBM Db2 Analytics Accelerator Studio | Scroll down to the Tables section. |
| IBM Data Server Manager | Click Manage . |

4. Start removing reference tables:

| | |
|--------------------------------------|---|
| IBM Db2 Analytics Accelerator Studio | <ol style="list-style-type: none">a. On the toolbar of the Tables section, select Federation > Remove Reference Tables.b. In the Db2 Subsystems window, you see a list of the Db2 subsystems that are paired with the same accelerator. Select one or more Db2 subsystems containing reference tables.c. Click Next. |
|--------------------------------------|---|

| | |
|-------------------------|---|
| IBM Data Server Manager | <p>a. Select Federation > Remove Reference.</p> <p>b. In the selection box labeled Db2 Subsystems, you see a list of Db2 subsystems that qualify as referencing Db2 subsystems, that is, subsystems that will query the remote tables. Select one or more of these subsystems.</p> |
|-------------------------|---|

5. Select the reference tables that you want to remove:

| | |
|--------------------------------------|---|
| IBM Db2 Analytics Accelerator Studio | <p>In the Db2 Tables window, you see a list of the tables on the accelerator. Select the reference tables that you want to remove by clicking the appropriate check boxes. To select all tables that belong to a schema, select the check box in front of the schema name.</p> <p>If the list is long, first narrow the choice by using the Name like filter field. Type the names of schemas or tables in this field, either fully or partially, to display just schemas and tables bearing or starting with that name. The names of tables that have already been selected are grayed out.</p> <p>To the right of the Name like field, you also find controls (icons) to do the following:</p> <ol style="list-style-type: none"> Select or deselect all tables Expand or collapse all schemas |
| IBM Data Server Manager | <p>In the selection box labeled Db2 Tables, select the reference tables that you want to remove by clicking the appropriate check boxes. To select all tables in the selection box, select the check box in front of the NAME column header.</p> <p>You can use a filter to limit the number of tables in the selection box:</p> <ol style="list-style-type: none"> Click  to display the search field. Type the names of tables in the search field, either fully or partially, to display just tables containing your search string. The names of tables that have already been selected are grayed out. |

6. Confirm:

| | |
|--------------------------------------|-----------------------|
| IBM Db2 Analytics Accelerator Studio | Click Finish . |
| IBM Data Server Manager | Click OK . |

7. Click **Finish**.

Results

The selected reference tables (referencing accelerator-only tables) are removed from the accelerator. Corresponding entries are removed from the catalog of the referencing Db2 subsystem.

Installing updates

Refer to the appropriate sections to update individual components or migrate from one version to another.

It is rarely necessary to update all listed components. However, if you must update more than one component, follow the suggested order.

Order in which to update components

1. IBM Db2 Analytics Accelerator for z/OS Version 5.1.0 FMIDs and program temporary fixes (PTFs) via SMP/E. See *Updating the z/OS base package* in the *Installation Guide*.
2. Prerequisite PTFs for Db2 10 for z/OS or Db2 11 for z/OS. See *Installing prerequisite PTFs for Db2 10 for z/OS or Db2 11 for z/OS* in the *Installation Guide*.
3. Administration client. See
 - [“Updating IBM Db2 Analytics Accelerator Studio” on page 222](#)
 - [Updating IBM Data Server Manager](#)
4. Access Server. See [“Updating the IBM Db2 Analytics Accelerator software, the Netezza Platform Software \(NPS\), the Access Server, or the replication engine” on page 209](#)
5. Replication engine. See [“Updating the IBM Db2 Analytics Accelerator software, the Netezza Platform Software \(NPS\), the Access Server, or the replication engine” on page 209](#)
6. IBM Db2 Analytics Accelerator software. See [“Updating the IBM Db2 Analytics Accelerator software, the Netezza Platform Software \(NPS\), the Access Server, or the replication engine” on page 209](#)
7. Netezza Platform Software (NPS). See [“Updating the IBM Db2 Analytics Accelerator software, the Netezza Platform Software \(NPS\), the Access Server, or the replication engine” on page 209](#).
8. Stored procedures. See *Updating the IBM Db2 Analytics Accelerator stored procedures* in the *Installation Guide*.
9. CDC Capture Agent. See *Updating the CDC Capture Agent* in the *Installation Guide*.

Updating the IBM Db2 Analytics Accelerator software, the Netezza Platform Software (NPS), the Access Server, or the replication engine

These are software components that run on the accelerator hardware, that is, the IBM PureData System for Analytics.

Related information

[Updating administration clients](#)

Refer to the appropriate section to update your administration client:

Updating accelerator components

The following software components run on the accelerator server: IBM Db2 Analytics Accelerator software (accelerator software), Access Server and replication engine (for the incremental update function), and the Netezza Platform Software (NPS). Refer to the appropriate topic in this section to update any of these.

Important: An update of the Netezza Platform Software (NPS) might require you to first update the Netezza Firmware (FDT), the Netezza Host Platform (HPF), or both. Check if this is the case by referring to the prerequisites website. The procedure to update the FDT or the HPS is also described here, under *Updating other Netezza software*.

Installing update packages for the accelerator

IBM Db2 Analytics Accelerator for z/OS software includes specific libraries and other code to be installed on the IBM PureData System for Analytics. Updates for the Access Server, the replication engine, and the Netezza Platform Software (NPS) are delivered in separate packages.

Before you begin

Make sure that the following conditions apply:

- Make sure that IBM Db2 Analytics Accelerator for z/OS has been successfully connected to Db2 for z/OS.
- IBM UNIX System Services is installed on your z/OS data server.
- You have a user ID and a password to log on to your z/OS data server. The user ID has read access to the z/OS UNIX file system (zFS).
- The user ID is authorized to run the SYSPROC.ACCEL_UPDATE_SOFTWARE stored procedure.

About this task

The entire installation or update procedure consists of several steps:

1. Installing the update packages on your z/OS data server.
2. Transferring the update packages to the accelerator.
3. Activating the newly installed software.

This topic covers step [“1” on page 210](#) only.

Procedure

1. Log on to your z/OS data server using a remote client, such as IBM Personal Communications.
2. Set the AQT_HOST_PACKAGE_DIRECTORY environment variable to the path in which the installation packages reside. By default, this is `<your_prefix>/usr/lpp/IBM/aqt/<version>/packages`, where

<your_prefix>

Is your customized path for SMP/E installations, starting from the root directory.

<version>

Is a directory name that identifies the product version, for example `/v5r1m0/`.

Important: The directory that AQT_HOST_PACKAGE_DIRECTORY points to requires multiple gigabytes (GB) of disk space. For example, if you work with multiple accelerators in a rolling upgrade scenario, you must have multiple instances of the installation packages in the file system. So make sure that the directory can accommodate all the files. The *IBM Db2 Analytics Accelerator for z/OS: Program Directory* lists the exact disk space requirements.

3. If the stored procedures are still at a previous level (version 4 or earlier), make sure that you keep your setting of AQT_INSTALL_PREFIX in the AQTENV data set.

It is still needed by the back-level stored procedures.

Results

Your local update directory now contains the accelerator update package `version.tar.z`.

Related information

[Updating other Netezza software](#)

Updates of the Netezza Firmware (FDT) and the Netezza Host Platform (HPF) cannot be installed with SMP/E and are therefore carried out by an IBM service engineer. Follow the steps here to open a support case (formerly called problem management record or PMR) and provide IBM support with the necessary information.

[IBM DB2 Analytics Accelerator for z/OS: Program Directory](#)

Transferring update packages for the accelerator

Transfer update packages for IBM Db2 Analytics Accelerator for z/OS, the Access Server, the replication engine, or the Netezza Platform Software (NPS) by completing the steps in this section.

Before you begin

Make sure that the following conditions apply:

- Suitable accelerator installation packages exist in the `usr/lpp/IBM/aqt/<version>/packages` directory on your z/OS data server, where `<version>` is a placeholder for a directory whose name indicates the product version. Update packages for the IBM Db2 Analytics Accelerator for z/OS software are named `version.tar.z`, where `version` is the first part of the package name, which indicates the version of the software. Update packages for the Access Server, the replication engine, or the Netezza Platform Software (NPS) are named differently.
- The value of the `AQT_HOST_PACKAGE_DIRECTORY` environment variable determines where your administration client looks for software updates. If it is not set correctly, the packages cannot be located and thus cannot be transferred or installed.
- The user ID has read and write access to the directory that the `AQT_HOST_PACKAGE_DIRECTORY` environment variable points to and to all of this directory's sub-directories. You specify this variable in the `AQTENV` data set. The `AQTENV` data set must be referenced by the Workload Manager (WLM) environment that was set up for the IBM Db2 Analytics Accelerator for z/OS stored procedures. To avoid a setup with obsolete or wrong entries, use the sample `AQTENV` data set that comes with IBM Db2 Analytics Accelerator for z/OS Version 5.1.x.

However, if the stored procedures are still at a previous level (version 4 or earlier), make sure that you copy the previous setting of `AQT_INSTALL_PREFIX` to your new `AQTENV` data set. It is still needed by the back-level stored procedures.

- When you transfer an NPS update package, it is checked whether the NPS version is compatible with the installed Netezza Firmware (FDT) and Netezza Host Platform (HPF) versions. If the NPS is incompatible, you must first update the FDT, the HPF, or both. These tasks, however, can only be completed with the help of IBM support and require a downtime of about one day. So, if the NPS update is really necessary, make sure that you plan it thoroughly in advance. For more information, follow the **Related information** link at the end of this topic.

Another caveat exists in connection with an NPS transfer: If the NPS package fails the compatibility check, the process ends prematurely without transferring any packages, no matter how many other packages were selected. It is therefore recommended that you first transfer packages for IBM Db2 Analytics Accelerator, the Access Server, or the replication engine, then activate these, and transfer and activate the NPS update in a later step.

About this task

The update packages are copied from the z/OS UNIX file system (zFS) to the accelerator, but are not yet activated. However, to actually use a new version, you must activate it. How to do this is described in a later topic. See the hint at the end of this topic.

Installing a software update invokes the `SYSPROC.ACCEL_UPDATE_SOFTWARE` stored procedure on your data server. For information about the privileges that are required to run this procedure and further details, see the appropriate section in the *IBM Db2 Analytics Accelerator for z/OS: Stored Procedures Reference*. A link to this document is provided under **Related reference** at the end of this section.

Procedure

1. Start your administration client.
2. Select the accelerator:

| | |
|--------------------------------------|---|
| IBM Db2 Analytics Accelerator Studio | a. In the Administration Explorer , select the Accelerators folder. |
|--------------------------------------|---|

| | |
|-------------------------|--|
| | b. In the Object List Editor , double-click an accelerator name to open the corresponding Accelerator view. |
| IBM Data Server Manager | a. Click  in the upper left. b. Select ADMINISTER > Accelerators . c. In the list of accelerators, select the name of the accelerator (row). |

3. Open the **Transfer Software Version** window:

| | |
|--------------------------------------|--|
| IBM Db2 Analytics Accelerator Studio | a. If necessary, expand the About section. b. In the About section, click the Transfer updates link. |
| IBM Data Server Manager | In the lower half of the Accelerator view, click Transfer Updates . |

4. In the **Transfer Software Version** or **Transfer Updates** window, you can see all software packages that are available in the zFS of your z/OS data server. Select the packages that you want to transfer:

| | |
|--------------------------------------|---|
| IBM Db2 Analytics Accelerator Studio | Select the appropriate check boxes in the first column of the package list. |
| IBM Data Server Manager | Select the appropriate row in the package list. Restriction: In IBM Data Server Manager you can only select and transfer one package at a time. To transfer additional packages, you must revisit the Transfer Software Version window and repeat this and the following step. |



Attention: Make sure that you select the proper packages, that is, packages belonging to the release level that you want to upgrade to. The list in the **Transfer Updates** window might be confusing, especially if it also contains older packages. To find the correct package numbers, see the closing information or the release notes for the latest maintenance level. You find the closing information or the release notes for a maintenance level on the support home page, in the category *Plan and install documentation* (see link under **Related information** at the end of this topic). If a maintenance release was shipped with a major product release, then, in general, you must transfer the packages included in the maintenance release rather than the packages in the base version.

5. Click **Transfer** to complete the installation.

Related information

[IBM DB2 Analytics Accelerator for z/OS: Stored Procedures Reference Plan and install documentation for DB2 Analytics Accelerator for z/OS](#)

Switching between available versions of accelerator software components

To use a recently transferred software package, you must first activate that package by selecting the version that the package contains. In the case of IBM Db2 Analytics Accelerator for z/OS software, you can also switch to an older version if one of your accelerators has problems with the newest version.

Before you begin

- You cannot activate a software version as long as a IBM Db2 Analytics Accelerator Console window is open. Therefore, close all console windows. You can check if there are any open console windows, and, if necessary, close these windows by following these steps:

| | |
|--------------------------------------|--|
| IBM Db2 Analytics Accelerator Studio | <ol style="list-style-type: none"> 1. Open the appropriate Accelerator view. 2. Scroll down to the Tables section and click List Tasks. 3. Cancel all active console tasks from the List Tasks window. |
| IBM Data Server Manager | <ol style="list-style-type: none"> 1. Select the appropriate accelerator (row) in the Accelerator view. 2. Click Manage. 3. Click List Tasks. 4. Cancel all active console tasks from the List Tasks window. |

- Consider the following points if you want to activate new versions of the Access Server, the replication engine, or both:
 - You cannot activate earlier versions of the Access Server or the replication engine. Just upgrades are possible here.
 - If incremental updates are enabled, stop these for each Db2 subsystem connected to the accelerator. To do this from your administration client:

| | |
|--------------------------------------|--|
| IBM Db2 Analytics Accelerator Studio | <ol style="list-style-type: none"> 1. In the Administration Explorer, select the Accelerators folder. 2. In the Object List Editor, double-click an accelerator name to open the corresponding Accelerator view. 3. In the header section of the Accelerator view, look for Replication: and click Stop. 4. Repeat the preceding steps for each Db2 subsystem connection to the same accelerator. |
| IBM Data Server Manager | <ol style="list-style-type: none"> 1. Click  in the upper left. 2. Select ADMINISTER > Accelerators. 3. In the list of accelerators, select the name of the accelerator (row). 4. In the lower half of the window, locate the Replication section and click the Stop button next to the Replication Status. |

| | |
|--|--|
| | 5. Repeat the preceding steps for each Db2 subsystem connection to the same accelerator. |
|--|--|

Note: If you have connections to Db2 data sharing groups (DSGs) and prefer to run the SYSPROC.ACCEL_SET_REPLICATION stored procedure from a client command line: It is not necessary to stop incremental updates for each individual member. A DSG is treated like a single connection and stopping incremental updates for the primary member will also stop these for the other members.

About this task

- The application of an update affects all Db2 subsystems that are connected to an accelerator.
- An update of the accelerator software does not automatically include the components for the incremental update function or the Netezza Platform Software (NPS). You must activate updates of the Access Server, the replication engine, and the Netezza Platform Software (NPS) separately.
- The activation of a different accelerator software version causes a restart of the accelerator.

Activating a software update invokes the SYSPROC.ACCEL_UPDATE_SOFTWARE stored procedure on your data server. For information about the privileges that are required to run this procedure and further details, see the appropriate section in the *IBM Db2 Analytics Accelerator for z/OS: Stored Procedures Reference*. A link to this document is provided under **Related reference** at the end of this section.



Attention:

- The activation of a new version of IBM Db2 Analytics Accelerator for z/OS software components might delete the query history from the accelerator if the new version introduces changes to the query history function.
- The sequence in which you activate the different software components is important. The sequence depends on the source and on the target version. To find the proper sequence for your particular update, see [“Order in which to update components” on page 209](#).
- When the accelerator is restarted with a new accelerator software version, accelerated queries cannot be processed on that accelerator before it reaches the *online* state. The only way to avoid a delay is to use a second accelerator in a workload balancing setup. That is, a second accelerator which is connected to the same Db2 subsystem, and which contains the same set of tables. Note that the tables must be loaded and enabled.

Procedure

1. Select the accelerator you want to apply a software update to:

| | |
|--------------------------------------|---|
| IBM Db2 Analytics Accelerator Studio | <ol style="list-style-type: none"> In the Administration Explorer, select the Accelerators folder. In the Object List Editor, double-click an accelerator name to open the corresponding Accelerator view. In the Accelerator view, from the Refresh drop-down list in the upper right, select Automatic off. <p>Otherwise, you might see warnings during the activation of the new software saying that the accelerator cannot be contacted.</p> |
| IBM Data Server Manager | <ol style="list-style-type: none"> Click  in the upper left. |

| | |
|--|--|
| | b. Select ADMINISTER > Accelerators . c. In the list of accelerators, select the name of the accelerator (row). |
|--|--|

2. Open the **Apply Software Version** wizard:

| | |
|--------------------------------------|--|
| IBM Db2 Analytics Accelerator Studio | a. If necessary, expand the About section. b. In the About section, click Apply other software version . |
| IBM Data Server Manager | a. In the lower half of the window, scroll down to the Server section. b. Click Apply other software version . |

3. On the first page of the **Apply Software Version** wizard, select the component whose active version you want to change:

| | |
|--------------------------------------|---|
| IBM Db2 Analytics Accelerator Studio | Accelerator IBM Db2 Analytics Accelerator for z/OS software Netezza Platform Software (NPS) Software for the Netezza hosts Access Server Access Server component for incremental updates Replication engine Replication engine or Apply Agent for incremental updates |
| IBM Data Server Manager | Accelerator IBM Db2 Analytics Accelerator for z/OS software Netezza Platform Software (NPS) Software for the Netezza hosts Access Server Access Server component for incremental updates Replication engine Replication engine or Apply Agent for incremental updates Optional Server Package Other software packages, such as the IBM Netezza Analytics package. |

Important: The order in which the wizard presents the components is not necessarily the order in which you must activate these. Use the same sequence for activating software components as for updating these. To find the proper sequence, see [“Installing updates”](#) on page 209.

4. Click **Next**.

5. On the second page of the **Apply Software Version** wizard, you can see all software packages on the accelerator that are currently available for the selected component.

In IBM Db2 Analytics Accelerator Studio, you can read information about a particular version before you activate it. To do so, select the appropriate entry in the list. The information is provided in the **Details of selected version** text box at the bottom.

6. Change the current version by selecting a different package.

The currently active package shows the value ACTIVE in the **Status** column. To change the current version, select a package with a status of INACTIVE:

| | |
|--------------------------------------|---|
| IBM Db2 Analytics Accelerator Studio | Select the appropriate radio button in the Switch To column. |
| IBM Data Server Manager | Select the appropriate entry (row) in the table. |

7. Click **Finish**.

Results

When the process has been completed successfully, a message similar to the following is displayed:

New software version was successfully activated.

Note: In some cases, migration processes are still ongoing even though the success message was displayed, for example after a restart of the Netezza database server. In a situation like this, it might take additional time until the accelerator is ready to process queries. You can check the status of an accelerator at the top of the corresponding **Accelerator** view. The status must be *online* for an accelerator to process queries.

What to do next

- **Important:** The function that applies incremental updates in parallel was improved in product version 5.1.x. However, if this function was enabled in version 4.1.x, the old function code is still executed. To use the new code after an upgrade to product version 5.1.0 or an even newer version, stop and then restart incremental updates on the updated accelerators. For instructions, follow the appropriate link at the end of this topic.
- To avoid a cluttered **Apply Software Version** window, you can remove packages from the accelerator that you no longer need.

For instructions on how to complete either task, follow the appropriate link under **Related tasks**.

Related tasks

[Removing obsolete software packages from an accelerator](#)

To free up space on an accelerator and reduce the number of versions that are displayed in the **Apply Software Version** window, you can remove packages that you no longer need.

[Starting or stopping incremental updates](#)

When a Db2 subsystem has been configured for incremental updates, you can start or stop incremental updates for attached accelerators from the corresponding accelerator views in your administration client. Using the functional links in the header starts or stops incremental updates for an entire accelerator.

Related information

[IBM DB2 Analytics Accelerator for z/OS: Stored Procedures Reference](#)

Updating other Netezza software

Updates of the Netezza Firmware (FDT) and the Netezza Host Platform (HPF) cannot be installed with SMP/E and are therefore carried out by an IBM service engineer. Follow the steps here to open a support case (formerly called problem management record or PMR) and provide IBM support with the necessary information.

1. In IBM Db2 Analytics Accelerator Studio, enable tracing for the accelerator that you want to update. A trace level of DEFAULT is sufficient.

For more information, see *Tracing* in the *IBM Db2 Analytics Accelerator Studio: User's Guide*.

2. Save the trace information to a file.

3. Open a support case at [IBM Support](#), preferably two weeks before the planned migration date. This gives IBM support enough time to analyze your system, coordinate maintenance actions, and update components as required.
4. If you plan to update the NPS, and the HPF or FDT updates are required for the NPS update, state this in the body of the support case. Also state the target NPS version.
5. Attach the trace file to the support case.

Transferring Netezza Firmware (FDT) updates or Netezza Host Platform (HPF) updates

When you have submitted the service request for the update, IBM support will tell you the proper download location and the names of the packages that you have to download. After finishing the download, transfer the update packages as a preparation for the IBM service personnel, who will help you install the updates on your IBM PureData System for Analytics.

Before you begin

Netezza update packages must exist in the download directory for packages of this type in the z/OS UNIX file system (zFS). Update packages for the Netezza host consist of single files only. The target system must be able to access this directory.

Important: The AQT_HOST_PACKAGE_DIRECTORY environment variable points to this download directory. It specifies an absolute path (starting from the root directory). The AQT_HOST_PACKAGE_DIRECTORY environment is set in the <HLQSP>.SAQTSAMP (AQTENV) data set, where <HLQSP> is the chosen high-level qualifier for stored-procedure libraries. The value of this environment variable determines where IBM Db2 Analytics Accelerator Studio looks for Netezza updates. If it is not set correctly, the packages cannot be located and thus cannot be transferred to the IBM PureData System for Analytics. To avoid a setup with obsolete or wrong entries, use the sample AQTENV data set that comes with IBM Db2 Analytics Accelerator for z/OS Version 5.1.x.

About this task

Netezza update packages are not installed automatically. They are just transferred to a directory on the IBM PureData System for Analytics, from where you must install them manually with the help of IBM support.

Transferring a Netezza update invokes the **SYSPROC.ACCEL_UPDATE_SOFTWARE** stored procedure on your data server. For information about the privileges that are required to run this procedure and further details, see the appropriate section in the *IBM Db2 Analytics Accelerator for z/OS: Stored Procedures Reference*. A link to this document is provided under **Related reference** at the end of this section.

To start an update transfer process, follow the steps in this section.

Procedure

1. Start your administration client.
2. Select the accelerator:

| | |
|--------------------------------------|---|
| IBM Db2 Analytics Accelerator Studio | <ol style="list-style-type: none"> a. In the Administration Explorer, select the Accelerators folder. b. In the Object List Editor, double-click an accelerator name to open the corresponding Accelerator view. |
| IBM Data Server Manager | <ol style="list-style-type: none"> a. Click  in the upper left. b. Select ADMINISTER > Accelerators. c. In the list of accelerators, select the name of the accelerator (row). |

3. Open the **Transfer Software Version** window:

| | |
|--------------------------------------|---|
| IBM Db2 Analytics Accelerator Studio | <p>a. If necessary, expand the About section.</p> <p>b. In the About section, click the Transfer updates link.</p> |
| IBM Data Server Manager | In the lower half of the Accelerator view, click Transfer Updates . |

4. In the **Transfer Software Version** or **Transfer Updates** window, you can see all software packages that are available in the zFS of your z/OS data server. Select the packages that you want to transfer:

| | |
|--------------------------------------|--|
| IBM Db2 Analytics Accelerator Studio | Select the appropriate check boxes in the first column of the package list. |
| IBM Data Server Manager | <p>Select the appropriate row in the package list.</p> <p>Restriction: In IBM Data Server Manager you can only select and transfer one package at a time. To transfer additional packages, you must revisit the Transfer Software Version window and repeat this and the following step.</p> |



Attention: Make sure that you select the proper packages, that is, packages belonging to the release level that you want to upgrade to. The list in the **Transfer Updates** window might be confusing, especially if it also contains older packages. To find the correct package numbers, see the closing information or the release notes for the latest maintenance level. You find the closing information or the release notes for a maintenance level on the support home page, in the category *Plan and install documentation* (see link under **Related information** at the end of this topic). If a maintenance release was shipped with a major product release, then, in general, you must transfer the packages included in the maintenance release rather than the packages in the base version.

5. Click **Transfer** to complete the installation.

Installing updates of the Netezza Firmware (FDT) or the Netezza Host Platform (HPF) software

While updates for IBM Db2 Analytics Accelerator for z/OS, the Access Server, or the replication engine are installed automatically at the end of the transfer process or by using the apply function, updates for the Netezza host are not. Therefore, you must install these updates manually.

Before you begin

Make sure that the following conditions apply:

- You have opened a support case as described in [“Updating other Netezza software”](#) on page 216.
- The IBM PureData System for Analytics must be fully operational. Hardware problems must not exist. This also means the use of spare disks is not allowed. Replace defective hard disks before installing the update.
- Remote access from z/OS OMVS to the Netezza host via secure shell (ssh) must be enabled.
- IBM support will ask you to open or allow a screen-sharing session on your workstation. Make sure that this complies with the security guidelines of your organization or ask the responsible staff for a special permit.

About this task

An update installation requires you to stop the Netezza database for approximately 30 minutes. The accelerator cannot be used during this time.

Procedure

1. Contact IBM support.

IBM support will ask you for remote screen-sharing access to the client machine.

2. With IBM assistance, open a login shell to the Netezza host.

There are several ways to do that:

- If a telnet server and a secure-shell (ssh) client are installed in the UNIX System Services file system of your System z®, you can connect with a network client application, such as PuTTY, from your client workstation to the Netezza host by opening the following connections:
 - a. From your workstation to the System z server by telnet. Use your user ID and password to log in. See an example of a telnet login from a PuTTY window:

```
EZKTE14I login: willy
EZKTE14I willy Password:
IBM
Licensed Material - Property of IBM
5694-A01 Copyright IBM Corp. 1993, 2011
(C) Copyright Mortice Kern Systems, Inc., 1985, 1996.
(C) Copyright Software Development Group, University of Waterloo, 1989.

All Rights Reserved.

U.S. Government Users Restricted Rights -
Use, duplication or disclosure restricted by
GSA ADP Schedule Contract with IBM Corp.

IBM is a registered trademark of the IBM Corp.
```

Note: The telnet connection from the workstation to the UNIX System Services telnet server will be unencrypted.

- b. From the System Z to the Netezza host by ssh. To open this connection, enter the **ssh** command followed by `root@<ip>` from the login window, where `root` is the root user ID and `<ip>` the IP address of the Netezza host. See the following example:

```
DCA1:WILLY:/u/willy>ssh root@10.104.9.3
Enter Service Password (Date: '20140506' Serial#: '1234' Rev: '2'):
```

In this example, the IP address of the Netezza host is 10.104.9.3. IBM support will enter the service password for you.

- If an ssh server and an ssh client are installed in the UNIX System Services file system of your System Z, and if server and client have been activated, you can connect with a network client application, such as PuTTY, from your client workstation to the Netezza system by opening the following connections:
 - a. From your workstation to the System Z server by ssh. Use your user ID and password to log in. See an example of an ssh login from a PuTTY window:

```
login as: willy
willy@boedca1's password:
```

Important: If your z/OS version is V2R2 or higher, make sure that the address space for the Cryptographic Service Facility (CSF) has been started. Otherwise, the ssh connection to z/OS will fail.

- b. From the System Z to the Netezza host by ssh. To open this connection, enter the **ssh** command followed by `root@<ip>` from the login window, where `root` is the root user ID and `<ip>` the IP address of the Netezza host. See the following example:

```
DCA1:WILLY:/u/willy>ssh root@10.104.9.3
Enter Service Password (Date: '20140506' Serial#: '1234' Rev: '2'):
```

In this example, the IP address of the Netezza host is 10.104.9.3. IBM support will enter the service password for you.

Note: IBM prefers this method over the telnet method because the connection to the System Z server is encrypted.

- If an ssh server is installed and active on your System Z, and if port-forwarding is enabled for that server, you can connect to the Netezza system by an ssh tunnel, which looks like a single connection from your client workstation to the Netezza system. To enable port-forwarding, set `AllowTcpForwarding yes` in the `/etc/ssh/sshd_config` file of your UNIX System Services file system and restart the ssh server for the change to take effect.

Example: The commands for a tunnel connection would look similar to these:

a. `ssh -L 10022:10.0.0.1:22 user@systemz`

where:

-L 10022

is the local port on the client workstation

10.0.0.1

is the IP address of the Netezza host

22

is the remote port or listening port on the Netezza host

user@systemz

user is ID with which you log on to the UNIX System Services ssh server and systemz is the host name of that server.

b. `ssh -p 10022 root@localhost`

where:

-p 10022

is the local port on the client workstation

root@localhost

root is the user ID on the Netezza host and localhost is the host name of the client workstation

After the login, IBM support will enter the service password for you.

Tip: IBM provides a tool package called IBM Ported Tools for z/OS, which is free of charge. One of the programs in this package is called OpenSSH, which contains an ssh client component that you can use to connect from the UNIX System Services file system to the Netezza host. Note that you only need the client component of OpenSSH for Netezza host updates (called **ssh**). For more information, see:

<https://www.ibm.com/systems/z/os/zos/features/unix/ported>

3. IBM Support will provide you with a temporary password that is valid for your Netezza host and the current date only.
4. Navigate to the directory on the Netezza host in which the transferred update files are stored. To do so, enter `cd /nz/dwa/transfer/accelerator` at the command prompt of your ssh client.
5. To proceed, follow the instructions of IBM support.
6. Having installed the updates, delete the files that are not needed anymore.
7. Terminate the ssh session by entering `exit` at the command prompt.

Removing obsolete software packages from an accelerator

To free up space on an accelerator and reduce the number of versions that are displayed in the **Apply Software Version** window, you can remove packages that you no longer need.

About this task

The removal wizard can remove all packages that have been deployed with the help of the transfer wizard, that is:

- Accelerator software packages
- Access Server packages
- Replication engine packages
- Netezza Platform Software (NPS)
- Netezza Firmware (FDT)
- Netezza Host Platform (HPF)

Note: You can only remove software packages from regular accelerators.

Procedure

1. Select the accelerator that you want to remove packages from:

| | |
|--------------------------------------|---|
| IBM Db2 Analytics Accelerator Studio | <ol style="list-style-type: none">a. In the Administration Explorer, select the Accelerators folder.b. In the Object List Editor, double-click an accelerator name to open the corresponding Accelerator view. |
| IBM Data Server Manager | <ol style="list-style-type: none">a. Click  in the upper left.b. Select ADMINISTER > Accelerators.c. In the list of accelerators, select the name of the accelerator (row). |

2. Open the **Remove Software Versions** window:

| | |
|--------------------------------------|---|
| IBM Db2 Analytics Accelerator Studio | <ol style="list-style-type: none">a. If necessary, expand the About section.b. In the sub-section labeled Server, click Remove. |
| IBM Data Server Manager | <ol style="list-style-type: none">a. In the lower half of the window, scroll down to the Server section.b. Click Remove. |

3. In the **Remove Software Versions** window, select the software packages that you want to remove. To do so, select the appropriate check boxes in the first column.

In IBM Db2 Analytics Accelerator Studio, information about the selected package is displayed under **Details of selected version**. You might want to use this information as a decision aid.

4. Click **Remove**.

What to do next

The removal wizard that is described in this topic can only remove packages from an accelerator. To free up space in the z/OS UNIX file system (zFS) of your data server, manually delete no longer needed IBM

Db2 Analytics Accelerator for z/OS or Netezza update packages from the zFS. To do so, open a UNIX System Services shell and delete the files by using the **rm** command.

Updating administration clients

Refer to the appropriate section to update your administration client:

Related information

[Updating the IBM Db2 Analytics Accelerator software, the Netezza Platform Software \(NPS\), the Access Server, or the replication engine](#)

These are software components that run on the accelerator hardware, that is, the IBM PureData System for Analytics.

Updating IBM Db2 Analytics Accelerator Studio

Follow the instructions here to download and install an upgrade of IBM Db2 Analytics Accelerator Studio.

About this task

You can no longer use IBM Db2 Analytics Accelerator Studio 3.2 for the administration of this product. You must upgrade to version 4.1.0 or a later version.

To download a refresh pack for IBM Db2 Analytics Accelerator Studio, a workstation with an internet connection is required.

If IBM Installation Manager is installed on a workstation without an internet connection, the program cannot automatically locate the repositories for updates of already installed products or additional plugins. Therefore, an administrator has to download the update repository to a central location that users without an internet connection have access to.

Workstation users without an internet connections can then let their local IBM Installation Manager installations point to the repository in the central location or copy the entire installation package from the central location to their workstations and go on from there.

You can use the newer versions of IBM Db2 Analytics Accelerator Studio with older versions of accelerators and stored procedures. Version 2.1.x and 3.1.x of IBM Db2 Analytics Accelerator for z/OS continue to work even if you have installed IBM Db2 Analytics Accelerator Studio Version 4.1.x or higher. However, the user interface might not show new functions until you update the stored procedures to the next higher or newest version (4.1.0 for version 4 functions or 5.1.0 for version 5 functions).

Procedure

- To download a refresh pack for yourself or for others from a computer with an internet connection:
 - a) Click the following link:
 - [Select fixes: IBM Db2 Analytics Accelerator Studio \(All releases, All platforms\)](#)
 - b) Select the proper refresh pack and click the **Continue** button above the list.
 - c) Sign in with your IBM ID or click **Create IBM id** and follow the instructions to create an IBM ID first.
 - d) Select your preferred download method:
 - **Download using Download Director** (requires Java enabled browser)
 - **Download using bulk FTP**
 - **Download using your browser (HTTPS)**
 - e) Leave the check box **Include prerequisites and co-requisite fixes (you can select the ones you need later)** selected.
 - f) In the **View and accept terms** window, click **I agree** to agree to the terms and conditions.
 - g) Click **Download now** and follow the instructions.

- h) Extract the content of the downloaded archive to a directory on your local workstation or to the central location (for access or download by other users).
- To update an IBM Db2 Analytics Accelerator Studio installation:
 - a) Start IBM Installation Manager.
 - b) Update IBM Db2 Analytics Accelerator Studio by using one of the following procedures:
 - The following approach works if you can still connect to a previously accessed IBM Installation Manager repository, and if that repository has been updated (contains the update):
 - a. Click **Update**.
 - b. Follow the instructions in the wizard. Deselect components that you do not want to update.
 - If the first method did not work, but you can access the repository file on your company's network or on your local workstation:
 - a. From the main menu of IBM Installation Manager, select **File > Preferences > Repositories**.
 - b. Click **Add Repository**.
 - c. Click **Browse** and navigate to the directory that contains the extracted update package, either in the central location, or on your local workstation.
 - d. Select the `repository.config` file and click **Open**.
 - e. Click **OK** twice to return the main window of IBM Installation Manager.
 - f. Click **Update**.
 - g. Follow the instructions in the installation wizard.

Differences to earlier versions and customization

IBM Db2 Analytics Accelerator Studio 4.1 differs in some respects from its predecessors. You might want to customize your installation so that it uses the workspace directory, default perspective, and language settings of earlier versions.

If you follow the steps in [“Updating IBM Db2 Analytics Accelerator Studio”](#) on page 222, IBM Data Studio Client 4.1 and IBM Db2 Analytics Accelerator Studio 4.1 are installed.

Earlier versions of IBM Db2 Analytics Accelerator Studio, for example version 3.1, used the InstallAnywhere program for the installation. In contrast, version 4.1 installs IBM Data Studio Client 4.1 by using IBM Installation Manager and adds the IBM Db2 Analytics Accelerator functionality as a third-party extension.

When comparing IBM Db2 Analytics Accelerator Studio 4.1 with version 3.1, you will notice the following differences:

- On Windows, the default folder in the start menu is named `\IBM Data Studio\` instead of `\IBM Db2 Analytics Accelerator Studio\`.
- The name of the default workspace is different. If you want to reuse your existing workspace for IBM Db2 Analytics Accelerator Studio, select the following directory path in the workspace launcher that is displayed when you start IBM Data Studio:

```
C:\Documents and Settings\\IBM\
Db2 Analytics Accelerator Studio 3.1\workspace
```

where `<username>` is the name of the log-on user. This is the default workspace directory for IBM Db2 Analytics Accelerator Studio Version 3.1. You might have used a custom directory with earlier versions of the program, in which case you must change your selection accordingly.

- When you start the IBM Data Studio Client, the **Accelerator** perspective is not the default perspective. To activate the **Accelerator** perspective, select **Window > Open Perspective > Other > Accelerator** from the menu bar.
- IBM Db2 Analytics Accelerator Studio Version 4.1 is available in English only. However, your version of IBM Data Studio might display some interface elements in the language that you specified in the regional settings of your operating system. To avoid a mixture of elements in English and another

language, configure the IBM Data Studio version that you use for IBM Db2 Analytics Accelerator for z/OS to display all interface elements in English only. To do that, follow these steps:

1. Locate the `eclipse.exe` file in the file path of your IBM Data Studio installation.
2. Start IBM Data Studio by running the following command:

```
eclipse.exe "-nl en_US"
```

On Windows, you can also complete these steps to the same end:

1. Right-click the **Data Studio 4.1 Client** shortcut and select **Properties** from the menu.
2. In the **Properties Wizard**, on the **Shortcut** tab, edit the **Target** field: At the end of the target entry, add a space character followed by `"-nl en_US"`.
3. Click **OK**.

Updating IBM Data Server Manager

Follow the instructions here to download and install an upgrade of IBM Data Server Manager.

About this task

To download a refresh pack for IBM Data Server Manager, a workstation with an internet connection is required.

Procedure

- To download a refresh pack for yourself or for others from a computer with an internet connection:
 - a) Click the following link:
[Select fixes: Information Management, Data Server Manager \(All releases, All platforms\)](#)
 - b) Select the proper refresh pack.
Important: The page also lists refresh packs for IBM Db2 Data Management Console (`datamgtconsole`). This is not the same as IBM Data Server Manager. Make sure to select only packages that are labeled *Data-Server-Manager*.
 - c) Click **Continue**.
 - d) Sign in with your IBM ID or click **Create IBM id** and follow the instructions to create an IBM ID first.
 - e) Select your preferred download method:
 - **Download using Download Director** (requires Java-enabled browser)
 - **Download using bulk FTPS/SFTP**
 - **Download using your browser (HTTPS)**
 - f) Leave the check box **Include prerequisites and co-requisite fixes (you can select the ones you need later)** selected.
 - g) Click **Continue**.
 - h) On the **Download files using ...** page, scroll down to the section that shows the name of the refresh pack in bold type.
 - i) Click the blue file name link with the download icon in front to start the download.
- To update a IBM Data Server Manager installation:
 - a) If necessary, transfer the downloaded package to the machine on which you want to install the update.
 - b) Depending on your operating system, take one of the following actions:
 - For AIX® and Linux:
 - a. Extract the content of the downloaded archive to an empty directory of your choice.

- b. Open a terminal window.
- c. Change to the directory that contains the extracted package content.
- d. Run **./setup.sh**.

If the web server of your previous installation is still running, the setup.sh program will tell you so and will also give you the process identification number (PID). You can then kill the process and restart the setup.sh program to continue.

- On Windows, start the update wizard by double-clicking the downloaded file. Follow the instructions in the wizard.

What to do next

To check if the upgrade works, open IBM Data Server Manager in a web browser and log on.

Switching from 24:00:00 conversion to native 24:00:00 support

If you have so far converted 24:00:00 time values to 23:59:59 by using the `LOAD_ENABLE_HOUR24_CONVERSION` configuration parameter and now want to use the native 24:00:00 support provided by newer versions of the Netezza Platform Software (NPS), you must remove this parameter or set it to the value `false`. In addition, you must reload accelerator-shadow tables that contain converted values.

Before you begin

The native 24:00:00 support was introduced with version 4 PTF-2 of the product. Therefore, before completing the steps listed hereafter, make sure that the following conditions apply:

- IBM Db2 Analytics Accelerator for z/OS Version 4 PTF-2 or higher has been installed.
- Your version of the Netezza Platform Software (NPS) is 7.0.2 P11 or a higher 7.0.2 version. Alternatively, you can use version 7.0.4.3 or higher.
- In case you use the incremental update function: your version of IBM InfoSphere Change Data Capture for z/OS (CDC) must be 10.2.1 or higher.

Procedure

1. Ask the network administrator or the person who did the TCP/IP setup for the IP address (virtual IP or wall IP address) of the accelerator. Make a note of this information. You need to enter it as you complete the steps that follow.
2. Start a client or emulator session (using, for example, IBM Personal Communications) to communicate with the z/OS system on which your Db2 subsystem is located.
3. Log on to TSO/ISPF.
4. Enter the following command:

```
tso telnet <hostname> 1600
```

where

<hostname>

Is the IP address of the accelerator that is connected to the Db2 for z/OS data server.

1600

Is the number of the port configured for accessing the IBM Db2 Analytics Accelerator Console using a telnet connection between the Db2 for z/OS data server and the accelerator.

For example:

```
tso telnet 203.0.113.8 1600
```

5. When prompted, enter the console password.
The initial password is `dwa-1234`. You must change this password at the first logon.

6. Press the Pause key, then Enter to display the following screen:

```
*****
*           Welcome to the IBM Db2 Analytics Accelerator Console
*****

You have the following options:

(1) - Change the Configuration Console Password
(2) - (Menu) Run Netezza Commands
(3) - (Menu) Run Accelerator Functions
(4) - (Menu) Manage Hardware
(5) - (Menu) Manage Incremental Updates
(6) - (Menu) Manage 'Call Home'
(7) - (Menu) Manage Encryption

-----
(x) - Exit the Configuration Console
```

7. Type 3 and press Enter to display the submenu:

```
main -> 3
-----
You have the following options:

(0) - Go back one level
(1) - Obtain pairing code, IP address, and port
(2) - List paired Db2 subsystems
(3) - Set resource limits for Db2 subsystems
(4) - Clear query history
(5) - Specify the priority of maintenance tasks
(6) - Set the Db2 subsystem for time synchronization
(7) - Restart accelerator process
(8) - Enable the conversion mode for 24:00:00 h values to 23:59:59 h
(9) N/A: - Disable the conversion mode for 24:00:00 h values to 23:59:59 h
(10) - Set a system-wide resource limit
```

8. Type 8 and press Enter.

This disables the conversion of 24:00:00 time values.

9. Type 0 and press Enter to go up one level.

10. Type x and press Enter to exit the console.

11. Reload accelerator-shadow tables that contain converted values.

To identify such tables, run the following queries in Db2 for z/OS (do not accelerate these queries!):

a. To identify accelerator-shadow tables with time columns:

```
SELECT RTRIM(C.NAME) AS COLNAME, RTRIM(C.TBCREATOR) AS TBCREATOR,
RTRIM(C.TBNAME) AS TBNAME
FROM SYSIBM.SYSCOLUMNS AS C, SYSACCEL.SYSACCELERATEDTABLES AS T
WHERE C.TBCREATOR = T.CREATOR AND C.TBNAME = T.NAME
AND C.COLTYPE = 'TIME';
```

b. To identify Db2 tables that contain 24:00:00 values, run the following query against each column that was listed as a result of the previous query:

```
SELECT COUNT(*) FROM MYCREATOR.MYTABLE WHERE TIMECOL = '24:00:00';
```

where

MYCREATOR

Stands for the name of any table creator listed in the result of query 1.

MYTABLE

Stands for the name of any table listed in the result of query 1.

TIMECOL

Stands for the name of any table column listed in the result of query 1.

c. The counterparts (projections) of these columns on the accelerator contain the converted values (23:59:59). Reload the accelerator-shadow tables that contain these columns.

Viewing the encryption status

You can check the encryption status of an accelerator from the corresponding accelerator view.

Procedure

1. To view the encryption status, first select the accelerator:

| | |
|--------------------------------------|---|
| IBM Db2 Analytics Accelerator Studio | <ol style="list-style-type: none">a. In the Administration Explorer, select the Accelerators folder.b. In the Object List Editor, double-click an accelerator name to open the corresponding Accelerator view. |
| IBM Data Server Manager | <ol style="list-style-type: none">a. Click  in the upper left.b. Select ADMINISTER > Accelerators.c. In the list of accelerators, select the name of the accelerator (row). |

2. Open the **Encryption Details** window:

| | |
|--------------------------------------|---|
| IBM Db2 Analytics Accelerator Studio | In the header of the Accelerator view, click the Encryption details link. |
| IBM Data Server Manager | In the lower half of the window, in the Diagnostics section, click the Encryption Details button. |

Results

The **Encryption Details** window shows the following information:

Disk Encryption

Shows whether disk encryption is used by your accelerator hardware.

Network Encryption

Shows the status of your network encryption setup.

Encrypted connections

This table contains details about the encrypted connections (IPsec tunnels) to the selected accelerator. This includes the names of the connecting client LPARs, their IP addresses, the IP addresses of the active and the passive accelerator host, the names of the certificates that are used, and the date and time when the connections were established.

If a connection does not work, the **Accelerator IP address** column in the **Encrypted connections** table shows *no active tunnel*.

Certificates

This table shows details about the certificates that are used, such as the validity, the type (user or root certificate), and the distinguished name.

Selected certificate in X.509 encoding

Shows the content of a certificate that is selected in the table above, in (encrypted) X.509 Base64 encoding. Naturally, the displayed content does not include the private keys because these must remain secret.

What to do next

Close the **Encryption Details** window to return to the accelerator view.

Chapter 6. Opening a support case

You might run into a situation in which you have to contact IBM support because you cannot solve an issue by yourself. A reason might be that specific updates or patches are required to successfully complete maintenance or repair jobs on the accelerator. Such jobs are usually carried out by an IBM service engineer. Follow the steps here to open a support case and provide IBM support with the necessary information.

1. In IBM Db2 Analytics Accelerator Studio, enable tracing for the accelerator that you want to update. A trace level of DEFAULT is sufficient.

For more information, see *Tracing* in the *IBM Db2 Analytics Accelerator Studio: User's Guide*.

2. Save the trace information to a file.
3. Open a support case at <https://www.ibm.com/mysupport/s>. Consider that IBM support needs some time to analyze your system, coordinate maintenance actions, and update components as required.
4. Attach the trace file to the support case.

Chapter 7. Status information about the system and the incremental update function

When the system has been properly configured, a heartbeat connection is established between the accelerator and the connected Db2 subsystems. Every 30 seconds, the heartbeat connection provides the Db2 subsystems with status information about the accelerator. You can view most of this information by using the `-DIS ACCEL Db2` commands. Detailed information about specific events cannot be viewed in this way, but is written to the z/OS system log (SYSLOG), in the form of DSNX881I messages. This includes messages that are related to the incremental update function.

To establish a heartbeat connection, an accelerator must have been paired successfully with a Db2 subsystem. In addition, the accelerator must have been started for that particular subsystem by the `-START ACCEL` command or by use of the corresponding function in your administration client.

To receive incremental-update-related event messages in a SYSLOG, IBM InfoSphere Change Data Capture for z/OS must have been installed and properly configured for use with the incremental update function of IBM Db2 Analytics Accelerator.

Support model

IBM Db2 Analytics Accelerator for z/OS is a solution that consists of various hardware and software components. Each of these components might issue a DSNX881I message. If the message indicates a hardware or software problem, open a support case with component ID (CompID) 5697AQT00.

Never open a support case for Netezza or the IBM PureData System for Analytics. Always use the IBM Db2 Analytics Accelerator CompID, even if the problem is related to Db2 for z/OS or to the attached accelerator hardware.

Your support case will be routed internally to the proper support request queue. Make sure that the support case contains an IBM Db2 Analytics Accelerator trace file that was obtained by using the **Save Trace** function in your administration client. Such a trace file does not only contain software trace messages, but also a complete set of diagnostic hardware information.

Consider using automatic DSNX881I notifications. This function, which became available with product version 4 PTF-4 can inform administrators of critical events and create support cases automatically.

DSNX881I message structure

Each DSNX881I message is made up of the following parts, which occur in the order indicated:

```
DSNX881I -<SSID> <MESSAGE-ID> <SEVERITY>  
<ACCELERATOR_MESSAGE_COUNTER> (<ACCELERATOR-TIMESTAMP>)  
ACCELERATOR-NAME (ACCELERATOR-IP) <MESSAGE-TEXT>
```

The placeholders have the following meaning:

SSID

Is the Db2 subsystem ID (SSID)

MESSAGE-ID

A numeric ID for the specific error message. This ID can be used for system monitoring.

Messages with IDs from 1 to 19 and from 21 to 2999

Accelerator heartbeat (system state) messages.

Messages with ID 20

These are incremental-update-related messages generated by IBM InfoSphere Change Data Capture for z/OS (CDC). They can be informational messages, warnings, or errors. Do not configure automatic notifications and support cases based on these messages, as the messages do not take the overall system state into account. In most cases, these messages are issued alongside

messages in the range from ID3000 to ID3999. Refer to the latter type of messages because these contain proper instructions and do take the overall system state into account.

Message with IDs from 3000 to 3999

These are messages related to the incremental update function. In contrast to the ID20 messages, these messages are more specific or might ask for a concrete intervention (manual or automated) on your part. They can be used to trigger automatic notifications and support cases.

SERVERITY

- I**
Information message
- W**
Warning message
- E**
Error message

ACCELERATOR_MESSAGE_COUNTER

An internal counter that increases with every additional error on the accelerator. If the text after the DSNX881I qualifier is longer than 255 characters, another DSNX881I message is issued. All messages belonging together will have the same <ACCELERATOR_MESSAGE_COUNTER> value. The <MESSAGE-TEXT> block of the each subsequent message contains a sequel to the information in the previous message.

ACCELERATOR-TIMESTAMP

The time when the error occurred on the accelerator. The internal clock of the accelerator is synchronized with the first Db2 subsystem that was connected to the accelerator.

ACCELERATOR-NAME

The name of the accelerator where the error occurred. This information is only sent for accelerators that are running a version of the accelerator server that is higher than V2-PTF6, V3-PTF3, or V4-PTF1. See the prerequisite website for information on how to determine the PTF number of your version.

ACCELERATOR-IP

The IP address of the accelerator on which the error occurred. This information is only sent for accelerators that are running a version of the accelerator server that is higher than V2-PTF6, V3-PTF3, or V4-PTF1. See the prerequisite website for information on how to determine the PTF number of your version. The field can be empty if no IP address can be determined. However, the parentheses will appear.

MESSAGE

A textual description of the error.

The length of a DSNX881I message does not exceed 255 characters. If more characters are needed, additional DSNX881I messages are written to the SYSLOG. If an LPAR contains multiple Db2 subsystems that are connected to the same physical accelerator, error messages are issued for every subsystem. That is, you see the same messages multiple times in the log, each time with a different subsystem ID (SSID).

If an accelerator is paired with a data sharing group (DSG), all members of the group can write messages to group's system logs (SYSLOGs), provided that the -START ACCEL command has been issued for all members. In this case, make sure that applications are in place that monitor the SYSLOGs. If all members of the DSG are located in the same logical partition (LPAR), there is only one SYSLOG to monitor (see [Figure 20 on page 233](#)). However, if the members are located in different LPARs, you need to monitor the SYSLOGs of all LPARs involved (see [Figure 21 on page 234](#)).

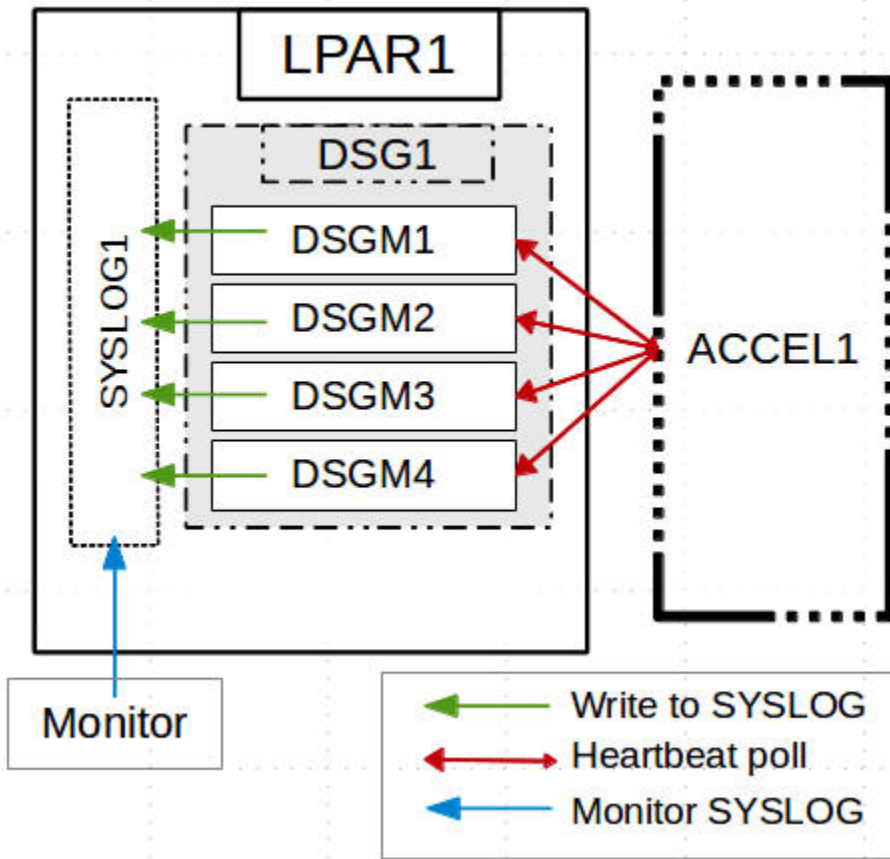

Figure 20. All members in the same LPAR

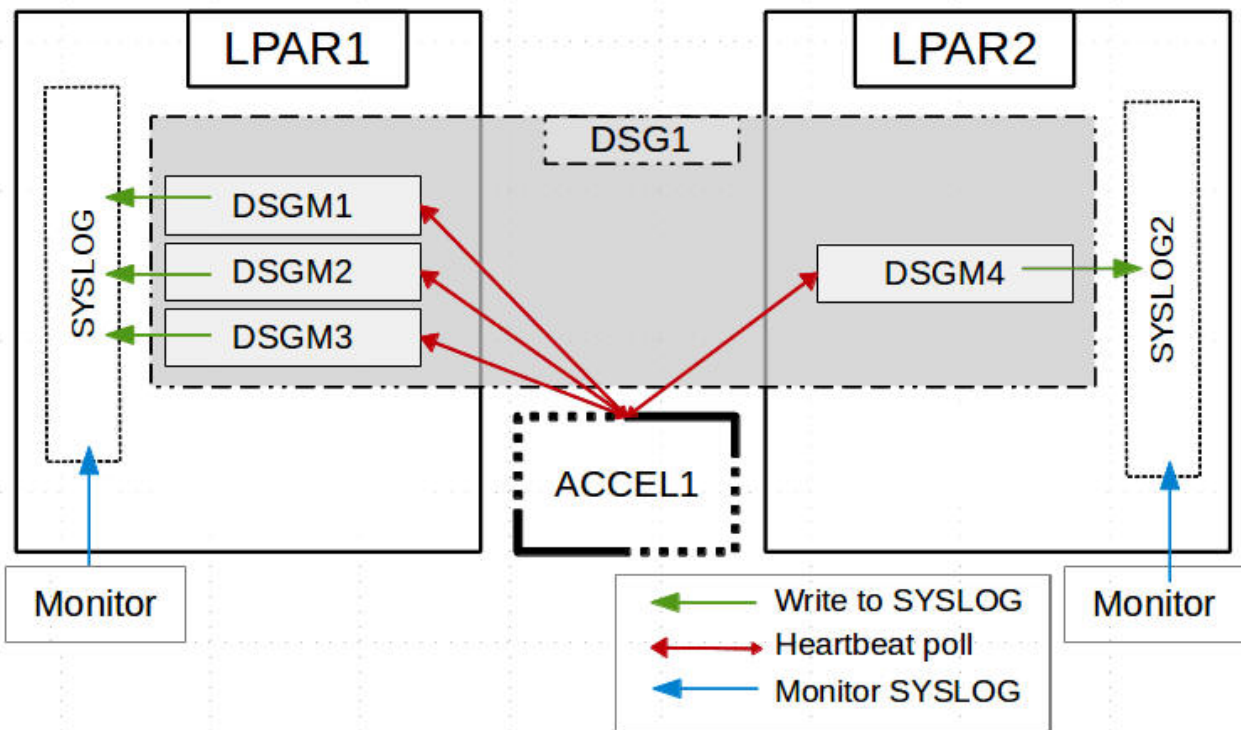

Figure 21. Members in two different LPARs

Note: It might look as if only one member writes messages to the SYSLOG, but this is actually a synchronization issue. If one member is always the first to issue a heartbeat request, then this member will receive all the messages and write these to the SYSLOGs. After that, the messages are deleted from the accelerator queue. The other members that send their heartbeat requests later will not receive these messages because the queue is empty. You might also see that only a few members write messages to the SYSLOG. This just means that the first member to send a heartbeat request is (always) found among this subset of members. The underlying mechanism is the same.

If an error occurs while an accelerator is in the *Stopped* state, that is, the `-STOP ACCEL` command has been issued before, an error message is stored on the accelerator. As soon as the accelerator becomes available again in Db2, the stored error messages are sent to the Db2 subsystem, provided that `-START ACCEL` has been issued for the subsystem, or, in case of a data sharing group, for at least one member of the group. It might happen that a DSNX881I message reports a past problem that has already been fixed.

For a list of message IDs, severity indicators, and message texts, see *Structure of DSNX881I Messages* (link under **Related information**).

Related information

- [Prerequisites and Maintenance for IBM DB2 Analytics Accelerator for z/OS Version 5.1](#)
- [Structure of DSNX881I Messages](#)

Chapter 8. Troubleshooting

In the following sections, you find descriptions of known IBM Db2 Analytics Accelerator for z/OS problems. The author and the development team have tried to provide a solution wherever possible. However, a solution might be unavailable because the cause of a problem cannot be clearly identified. This is mostly the case if multiple causes can lead to the same symptom. It can also be that a solution has not yet been found. In such cases, contact IBM support.

Important: During a customer session with IBM support, system parameters might be changed. For the parameter changes to take effect, a restart of an accelerator is often required. In such situations, the accelerator will be unavailable for operational tasks until it has come back online.

Redundant CDC metadata

When you start the CDC Capture Agent on z/OS, a warning is written to the CHCRPRT report data set.

Symptoms

The following message is added to the report:

The following tables are defined for replication, but are not used in any subscriptions. These can cause the product to perform inefficiently and should be removed from the list of replication tables if not required.

Causes

Incremental updates were disabled for one or more accelerator-shadow tables. However, the CDC metadata describing these tables still exists.

Resolving the problem

You can ignore this message because the impact on the performance is negligible. If you want, you can remove the redundant metadata by using a function on the IBM Db2 Analytics Accelerator Console.

Mind that the removal function removes only redundant CDC metadata, but not the metadata of tables that are still actively replicated.

For more information, see *Removing unused table metadata* in the *IBM Db2 Analytics Accelerator for z/OS: Installation Guide*.

Firewall blocks operations because crucial ports are closed

If product functions are not executed, check your firewall settings. IBM Db2 Analytics Accelerator requires certain ports to be open. See the table in this topic.

Symptoms

- You cannot accelerate queries.
- You cannot run functions from the IBM Db2 Analytics Accelerator Console.
- Incremental updates do not work or IBM InfoSphere Change Data Capture for z/OS cannot be configured.
- You cannot open a secure-shell (ssh) connection to an accelerator.
- Services are unavailable or switches (routers) cannot be reached because ICPM (Internet Control Message Protocol) traffic is blocked.

Causes

Required networking ports are closed.

Resolving the problem

| Function or protocol | Required port | Direction |
|---|---------------|--|
| Query execution (DRDA protocol) | 1400 | Both ways |
| IBM Db2 Analytics Accelerator Console | 1600 | Both ways |
| CDC data transfer | 11301-11400 | Outbound (from z/OS to accelerator) |
| CDC configuration | 5999 | Inbound (generally from accelerator to z/OS; depends on the configuration of the CDC Capture Agent) |
| Db2 DDF port (for continuous incremental updates) | 446 (default) | Inbound (from accelerator to z/OS) |
| Secure shell connection (ssh) | 22 | Both ways |
| ICMP traffic | N/A | Both ways |

IBM Db2 Analytics Accelerator Studio does not start

If IBM Db2 Analytics Accelerator Studio does not start, the reason might be that the name of the starting user contains a number sign (#).

Symptoms

IBM Db2 Analytics Accelerator Studio does not start.

Causes

At installation time, IBM Db2 Analytics Accelerator Studio creates a workspace directory in

```
@user.home\IBM\Db2 Analytics Accelerator Studio 2.1\workspace
```

where @user.home is the user's home directory, which is usually the same as the user name.

This means, if the user name contains a number sign (#), the workspace directory path contains a number sign, too. IBM Db2 Analytics Accelerator Studio cannot handle workspace directory paths that include number signs.

Resolving the problem

1. If the user name contains a number sign (#), open the file `datastudio.ini` in a text editor. This file is located in the installation directory of IBM Db2 Analytics Accelerator Studio.
2. Remove the following entries:

```
-data
@user.home\IBM\Db2 Analytics Accelerator Studio 2.1\workspace
```

3. Save and close the file.
4. The next time you start IBM Db2 Analytics Accelerator Studio, you are asked for the workspace directory path. This allows you to enter an alternative path that does not contain a number sign.

IBM Db2 Analytics Accelerator Studio on Linux does not start

IBM Db2 Analytics Accelerator Studio does not start from certain versions of Linux, particularly SUSE Linux Enterprise Server 10 with service pack 4.

Symptoms

An error message similar to the following is displayed:

```
/opt/tools/isaostudio/./jre/bin/javaw: symbol lookup error:
/usr/lib/xulrunner-1.9.2.17/libxul.so: undefined symbol
gdk_screen_get_resolution
```

Causes

An updated version of a required library (XULRunner) is not compatible with IBM Db2 Analytics Accelerator Studio.

Resolving the problem

Use an earlier version of the XULRunner library. The problem also occurs in connection with IBM Rational® Performance Tester. You can apply the suggested solution analogously. See:

<https://www.ibm.com/support/docview.wss?uid=swg21393436>

Message AQT10200E and SQL code -206 when running stored procedures after migration

Stored procedure calls end with message AQT10200E and SQLCODE= -206 after a migration of IBM Db2 Analytics Accelerator for z/OS from version 2.1.x to a later version.

Symptoms

The following message is displayed:

```
AQT10200E - The OPEN CURSOR operation failed. Error information: "DSNT408I
SQLCODE = -206, ERROR:  ARCHIVE IS NOT VALID IN THE CONTEXT WHERE IT IS USED"
```

Causes

Required program temporary fixes (PTFs) for Db2 for z/OS have not been installed or the respective ++HOLD migration actions have not been applied yet.

Resolving the problem

Follow the steps in section *Installing prerequisite PTFs for Db2 10 for z/OS* of the *IBM Db2 Analytics Accelerator for z/OS: Installation Guide*.

Package not found when running a stored procedure from IBM Db2 Analytics Accelerator Studio

You receive a message saying that a package was not found when you try to run an IBM Db2 Analytics Accelerator for z/OS stored procedure from IBM Db2 Analytics Accelerator Studio.

Symptoms

You receive a message similar to this one:

```
SQL0805N  Package "<location>.NULLID.SYSSTAT.5359534C564C3031"
was not found.  SQLSTATE=51002
```

Causes

The package has not been bound due to an IBM Db2 Analytics Accelerator Studio installation error.

Resolving the problem

Bind the package manually. The following methods can be used:

- From the Db2 command-line client:

1. `cd <Db2-client-install-folder>\bnd`

where <Db2-client-install-folder> is the fully qualified path to the installation folder of the Db2 command-line client.

2. `db2 connect to <database-name>`

where <database-name> is the database to which the stored procedure belongs.

3. `db2 bind @db2cli.lst grant public`

- Using the Db2Binder utility from a Windows command-prompt:

1. Adjust the following command as needed. Then press the Enter key.

```
cd /d <idaa-studio-install-directory>
\plugins\com.ibm.datatools.db2_2.1.403.v20120228_2105\driver
```

where <idaa-studio-install-directory> is the drive and installation directory of IBM Db2 Analytics Accelerator Studio on your local workstation, for example C:\Program Files\IBM\ IBM Db2 Analytics Accelerator Studio 2.1. The full name of the com.ibm.datatools.db2_ directory changes with each new driver. So make sure that you choose the correct directory.

2. Enter:

```
..\..\..\jre\bin\java -cp db2jcc4.jar;
db2jcc4_license_cisuz.jar;
db2jcc4_license_cu.jar com.ibm.db2.jcc.Db2Binder
-url jdbc:db2://<server>:<port>/<location>
-user <user-id> -password <password>
```

where

<server>

Is the host name of the Db2 data server

<port>

Is the port on which the Db2 data server listens to JDBC requests

<location>

Is the unique name of the database server. An application uses the location name to access a Db2 database server. A database alias can be used to override the location name when accessing a remote server.

<user-id>

Is a user ID with the privilege of running the Db2 Binder utility

<password>

Is the password belonging to <user-id>

Removing orphaned system-table entries and catalog-table entries

If an IBM PureData System for Analytics was physically removed, but the accelerator was not removed before by running the *Remove accelerator* function from your administration client or by running the SYSPROC.ACCEL_REMOVE_ACCELERATOR stored procedure, you find invalid entries in a number of Db2 for z/OS catalog tables and system tables.

Symptoms

You find invalid entries in the following tables:

- SYSIBM.IPNAMES
- SYSIBM.USERNAMES

- SYSIBM.LOCATIONS
- SYSACCEL.SYSACCELERATORS
- SYSACCEL.SYSACCELERATEDTABLES

Resolving the problem

1. Disable the accelerator in the Db2 subsystem, by using the `-STOP ACCEL` command or the appropriate function in your administration client.
2. To remove the invalid entries from the system tables, run the following SQL commands in the order indicated:

a.

```
DELETE FROM SYSIBM.IPNAMES
WHERE LINKNAME=(SELECT LINKNAME FROM SYSIBM.LOCATIONS
WHERE LOCATION=(SELECT LOCATION FROM SYSACCEL.SYSACCELERATORS
WHERE ACCELERATORNAME=<acceleratorName>));
```

b.

```
DELETE FROM SYSIBM.USERNAMES
WHERE LINKNAME=(SELECT LINKNAME FROM SYSIBM.LOCATIONS
WHERE LOCATION=(SELECT LOCATION FROM SYSACCEL.SYSACCELERATORS
WHERE ACCELERATORNAME=<acceleratorName>));
```

c.

```
DELETE FROM SYSIBM.LOCATIONS
WHERE LOCATION=(SELECT LOCATION FROM SYSACCEL.SYSACCELERATORS
WHERE ACCELERATORNAME=<acceleratorName>);
```

d.

```
DELETE FROM SYSACCEL.SYSACCELERATORS
WHERE ACCELERATORNAME=<acceleratorName>;
```

e.

```
DELETE FROM SYSACCEL.SYSACCELERATEDTABLES
WHERE ACCELERATORNAME=<acceleratorName>;
```

Long-running tasks are not completed

Tasks started from an administration client are not completed if they need more than two minutes of time, as, for example, the loading of an accelerator-shadow table.

Symptoms

The progress indicator never reaches the end or runs in an endless loop. You never receive a message that reports the successful completion or failure of the task.

Causes

A Db2 timeout setting (IDLE THREAD TIMEOUT parameter) prematurely ends the process (DDF thread) before the task is completed. The default value of this parameter is 2 minutes.

Resolving the problem

Increase the Db2 timeout value. For instructions, follow the link at the end of this topic.

Related information

[IDLE THREAD TIMEOUT field \(IDTHTOIN subsystem parameter\)](#)

SQL code -430 from IBM Db2 Analytics Accelerator for z/OS stored procedures

A stored procedure of IBM Db2 Analytics Accelerator for z/OS ends abnormally, and you receive an error message with SQL code -430.

Symptoms

IBM Db2 Analytics Accelerator for z/OS stored procedures end abnormally. Your administration client displays a message window like this one:



Figure 22. SQL code -430 message window

Causes

This is probably a configuration problem.

Diagnosing the problem

1. Verify that the IBM Db2 Analytics Accelerator for z/OS stored procedures run in a separate Workload Manager (WLM) environment. Each application environment must be set up according to the instructions in *Setting up a WLM application environment for IBM Db2 Analytics Accelerator for z/OS stored procedures* in the *IBM Db2 Analytics Accelerator for z/OS: Installation Guide*. In particular, the ADMIN_INFO_SYSPARM and DSNUTILU stored procedures must run in different WLM environments and NUMTCB must be set to the correct value.
2. Rerun the AQTJSJI00 and AQTJSJI01 jobs to verify the correct installation of the IBM Db2 Analytics Accelerator for z/OS stored procedures.

Database access problems after updating IBM Db2 Analytics Accelerator Studio or IBM Optim Query Tuner

IBM Db2 Analytics Accelerator Studio or IBM Optim™ Query Tuner no longer run successfully after an upgrade to a new version. A message says that privileges to access the database are missing.

Symptoms

A text similar to the following is displayed as part of the error message:

```
STEFANA DOES NOT HAVE THE PRIVILEGE TO PERFORM OPERATION EXECUTE PACKAGE
ON OBJECT DB      20SC.DSN50ADM. SQLCODE=-551, SQLSTATE=42501, DRIVER=3.58.81
```

Causes

A bind step has not been executed or users lack an execution privilege.

Diagnosing the problem

A bind step must be executed before a new version of IBM Db2 Analytics Accelerator Studio or IBM Optim Query Tuner can be employed. However, after carrying out the bind step, only the user who ran the command has the privilege to access the database from IBM Db2 Analytics Accelerator Studio or IBM Optim Query Tuner. If other users want to use IBM Db2 Analytics Accelerator Studio or IBM Optim Query Tuner, you must grant them this privilege.

Resolving the problem

1. To create and bind the Db2 packages, follow the instructions on this website:
https://www.ibm.com/support/knowledgecenter/SS62YD_4.1.1/com.ibm.datatools.qrytune.configothers.doc/topics/enabledb2zfromclient_ds.html
2. To grant the EXECUTE privilege to other users, proceed as follows:
 - a. In the Data Source Explorer in the IBM Data Studio client, expand the connection to the subsystem. Right-click the icon for the subsystem and select **Analyze and Tune > Configure for Tuning > Advanced Configuration and Privilege Management**.
 - b. Click **Manage Package Privileges** to display and modify the authorization IDs that can execute the tuning packages.

DRDA connection does not work

You can ping the accelerators, but you cannot establish a distributed relational database access (DRDA) connection between your database management system and the accelerator.

Symptoms

Db2 commands or IBM Db2 Analytics Accelerator for z/OS stored procedures cannot establish a TCP/IP connection with the accelerator. Running the SYSPROC.ACCEL_TEST_CONNECTION stored procedure reveals this issue.

Resolving the problem

Make sure that the distributed data facility (DDF) of Db2 for z/OS uses the same TCP/IP stack as the ping program.

Different results for floating-point aggregates

Queries that involve floating-point aggregates produce different results when processed by IBM Db2 Analytics Accelerator for z/OS rather than Db2 for z/OS.

Symptoms

The very same query is processed twice, once by IBM Db2 Analytics Accelerator for z/OS and once by Db2 for z/OS. The results are different.

Causes

The result differences are differences in precision or error tolerances, which are caused by different methods of representation for floating-point numbers.

Resolving the problem

The problem cannot be solved. The differences must be accepted.

Related concepts

[Differences in floating-point error tolerances](#)

For queries that involve floating-point aggregates, you can expect IBM Db2 Analytics Accelerator for z/OS to produce results that are different from those delivered by inhouse Db2 for z/OS processing.

Replication column not shown

The **Replication** column is not displayed in the **Object List Editor**, although the incremental update function has been enabled for one or more accelerators.

Symptoms

You do not see the **Replication** column in the **Object List Editor**, and there is no way to select it for display.

Causes

To be able to remember the last column selection of a user, IBM Db2 Analytics Accelerator Studio saves information to a couple of files. These files are not overwritten when IBM Db2 Analytics Accelerator Studio is updated. So if you updated IBM Db2 Analytics Accelerator Studio, it still uses the column information that was saved by the older version of the program. The column information was probably created when the incremental update function did not exist. Hence there can be no information about the **Replication** column.

Resolving the problem

You must delete two files so that they are created anew when you start IBM Db2 Analytics Accelerator Studio the next time:

1. In a **Command Prompt** window or file manager, change to the following directory:

```
<Data-Studio-workspace>\.metadata\.plugins\com.ibm.datatools.uom.ui
```

where <Data-Studio-workspace> is the workspace or working directory of IBM Data Studio. If you do not know your workspace path, select **File > Switch Workspace > Other** from the main menu to find out.
2. In this directory, delete the following files:
 - custom_properties.dat
 - property_arrangement.dat
3. Start IBM Db2 Analytics Accelerator Studio. If you do not see the **Replication** column in the **Object List Editor**, pick it from the column selection dialog.

Replication status: *ERROR*

To analyze a problem indicated by a replication status of *ERROR*, you can check the event list on the IBM Db2 Analytics Accelerator console for details.

Symptoms

The header of an accelerator view shows **Replication status: ERROR**.

Resolving the problem

1. Open the IBM Db2 Analytics Accelerator console as described in *Enabling incremental updates for a Db2 subsystem* in the *IBM Db2 Analytics Accelerator: Installation Guide*.
2. Enter 11 to select the option (11) - Show replication events on a subsystem.
3. Locate and read the error information.

4. If possible, take corrective action.

Table removal very slow

The removal of replication-enabled accelerator-shadow tables takes excessively long.

Symptoms

The removal process seems to run endlessly.

Resolving the problem

Stop the incremental update process for the accelerator before removing the tables. Proceed as follows from your administration client:

1. Cancel the running removal process.
2. Stop incremental updates for the accelerator.
3. Remove the accelerator-shadow tables.
4. Restart incremental updates for the accelerator.

Repeated IBM InfoSphere Change Data Capture for z/OS errors after abnormal end of Db2 for z/OS

IBM InfoSphere Change Data Capture for z/OS repeatedly reports errors after an abnormal end of Db2 for z/OS.

Symptoms

An error message similar to the following is displayed:

```
CHC9210E (CDCSZA1) Db2 CAF IFI-READS request has failed. ReturnCode=X'00000100',  
ReasonCode=X'00F30018'
```

Causes

If incremental updates are configured, and Db2 for z/OS ends unexpectedly, IBM InfoSphere Change Data Capture for z/OS is not notified of the shutdown. IBM InfoSphere Change Data Capture for z/OS still “expects” to find the instance of Db2 that was previously running. When Db2 for z/OS is restarted, IBM InfoSphere Change Data Capture for z/OS tries to renew the connection to the known Db2 instance. That is, it uses the session configuration or parameters of the previously stalled connection. These will never be correct, so the error message is displayed after each retry.

Resolving the problem

Restart the IBM InfoSphere Change Data Capture for z/OS address space.

Stored procedure calls fail with message AQT10206I while temporary files are being created

Some or all running instances of the IBM Db2 Analytics Accelerator for z/OS stored procedures fail during the creation of temporary files.

Symptoms

Message AQT10206I is displayed for each failed stored procedure call:

```
AQT10206I - The OPEN NEW operation on the "/tmp/aqt-stored-procedure-trace-XXX"  
file, data set, or pipe failed. Diagnostic information: mkstemp() failed with  
rc = -1 and errno = 133
```

Causes

IBM UNIX System Services provides a z/OS UNIX file system (zFS) for z/OS. This file system, which contains the directory for the storage of temporary files (/tmp), is full. No more temporary files can be created for the execution of stored procedures.

Resolving the problem

Delete no longer needed files from the zFS. For example, you can safely delete stored-procedure trace-files. Note that you need superuser privileges in IBM UNIX System Services to do that. Follow these steps to delete the stored-procedure trace-files:

1. Log in to the IBM UNIX System Services shell of the logical partition (LPAR) from where you started the IBM Db2 Analytics Accelerator for z/OS stored procedure that returned the error. To log in, you can open a secure shell (ssh) window and use the **su** command to log in with superuser privileges. You can also use the IBM UNIX System Services shell to log in directly with an ID that has the required superuser privileges.
2. Change to the /tmp directory:

```
cd /tmp
```

3. Delete the stored-procedure trace files:

```
rm aqt-stored-procedure-trace*
```

Query history is not displayed - error message returned

The query history is not displayed in the **Accelerator** view and a corresponding error message is returned.

Symptoms

You do not see valid values in the columns of the **Query Monitoring** section of the **Accelerator** view and a message similar to the following is displayed:

```
[2013-05-25 05:14:09,790] [ERROR] [HistoryCol] Query History collection  
impossible com.ibm.db2.jcc.am.SqlException: UNSUCCESSFUL EXECUTION CAUSED  
BY AN UNAVAILABLE RESOURCE. REASON 00C900D1, TYPE OF RESOURCE 00000907,  
AND RESOURCE NAME. SQLCODE=-904, SQLSTATE=57011, DRIVER=4.15.79
```

Causes

The value of the Db2 for z/OS parameter LOBVALA might be too low.

Resolving the problem

Increase the value of the LOBVALA parameter. The default value is 10240. Set it to 20480. Increase the value further if this does not solve the problem.

Db2 for z/OS returns SQLCODE -30040

A query cannot be executed and SQLCODE -30040 is returned by Db2 for z/OS.

Symptoms

Db2 for z/OS reports SQLCODE -30040, after IBM Db2 Analytics Accelerator has reported a DRDARessourceLimitError (DRDA code point 0x1233) and one of the following reason codes:

Reason 0x00001304 Type 0x00001409

The allowed maximum of concurrently running queries has been reached or exceeded. Your actual maximum depends on your hardware resources. The minimum is 100, the (theoretical) maximum is 240 queries running in parallel.

Reason 0x00000301 Type 0x00001409

The accelerator state forbids the execution of the query. For example, if the state is *Initializing* or *Maintenance*, queries cannot be processed.

Resolving the problem

1. Depending on the reason code, wait for earlier queries to finish or wait for the accelerator to change to a state that permits query execution.
2. Resubmit the failed query.

Query fails with SQLSTATE: HY000 SQLCODE: 46 'ERROR'

A running query fails when a distribution key or organizing key is changed at the same time. The message SQLSTATE: HY000 SQLCODE: 46 'ERROR' is returned.

Symptoms

The full error message is similar to the following:

```
SQLSTATE: HY000 SQLCODE: 46 'ERROR: RelationClearRelation: relation
'PARTSUPP-UID_01200030' (2881502) in database 2842888 altered in a concurrent
session'.
```

The problem occurs in connection with Netezza Platform Software (NPS) 7.0.4.

Resolving the problem

Rerun the query.

Restoring of archived partition fails with 'Duplicate key' error

You cannot restore a partition that was archived by the High Performance Storage Saver. The **Restore** function in your administration client or the SYSPROC.ACCEL_RESTORE_ARCHIVE_TABLE stored procedure fails with a message that hints at a duplicate key.

Symptoms

While restoring an archived partition, you receive error message AQT0301I from a stored procedure with the following description of a utility error in the message details:

```
DSNU340I, ERROR LOADING INDEX, DUPLICATE KEY
```

Causes

The problem is known to occur after the following series of events:

1. You have created a range-partitioned table with a unique index or primary key and the unique constraint consists of a set of columns that is different from the columns used in the partitioning key.
2. You have loaded the table and refreshed the table data on the accelerator.
3. You have archived one or more partitions of the table.
4. One or more rows have been inserted in an active partition of the table. Some of the values in the unique constraint columns of these rows match the unique constraint values of rows in the archived partition. The new rows could be inserted successfully because only the active data is checked for duplicate entries.
5. You restore the archived partition and thus end up with duplicate values for the unique constraint.

Resolving the problem

You can only solve this problem by eliminating its cause. That is, make sure that unique constraint values are not used in rows to be inserted in your active tables if these values were already used in a archived partition.

Table definition fails with error message AQT1005I

You cannot define a table on an accelerator. Message AQT1005I is displayed.

Symptoms

The full error message is similar to the following:

```
AQT1005I - An internal error occurred on the <accelerator-name> accelerator:  
An assertion 'rowLength <= internal::CatalogConstants::MAXIMUM_NETEZZA_ROW_LENGTH'  
failed. Additional info: Maximum row length 122464 of table  
<schema-name>.<table-name> exceeds limit 65535
```

Causes

The table contains column definitions that would exceed the maximum row length for accelerator-shadow tables (total length of all column fields in a row). The maximum row length is 65535 bytes.

Example:

```
CREATE TABLE <NAME> (  
  A VARCHAR(32704) FOR MIXED DATA NOT NULL  
);
```

On the accelerator, the corresponding accelerator-shadow table is created as follows:

```
CREATE TABLE <NAME> (  
  A NVARCHAR(16000) NOT NULL  
);
```

The definition of the CHAR FOR MIXED DATA column A in the original Db2 table already exceeds the maximum row length of an equivalent NVARCHAR column on the accelerator. However, this can still be fixed by reducing the column length to the allowed maximum of 16000 characters.

Each character in an NVARCHAR column has a length of four bytes. After the reduction, the total row length is $16000 * 4$ plus a few additional bytes, which would equal some 64000 bytes. Hence the length of column A lies within the limit. Since the table has only this one column, the total row length of the entire table does not exceed the limit either. However, during a load of the accelerator-shadow table, original Db2 string values exceeding the limit will be truncated after the first 16000 characters.

In contrast, the following Db2 table cannot be added to the accelerator because the maximum row length is exhausted by the definition of column A. With the definition of column B, the maximum row length would be exceeded by far. A reduction of the column length is not possible because the maximum row capacity has already been used up by column A.

```
CREATE TABLE <NAME> (  
  A VARCHAR(16000) FOR MIXED DATA NOT NULL,  
  B VARCHAR(16000) FOR MIXED DATA NOT NULL  
);
```

Resolving the problem

To define an accelerator-shadow table that exceeds the maximum row length, you must change its source table in Db2 for z/OS, that is, define fewer columns or columns with a shorter field length.

SQL error as you try to enable tables for incremental updates

The incremental update function is enabled, but you cannot enable tables to be included in the process.

Symptoms

You receive an error message that is similar to this one:

```
Db2 SQL Error: SQLCODE=-551, SQLSTATE=42501,  
SQLERRMC=CDCIDAA;UPDATE;CDCUSER.DMMD_SIGNALS.SIGNAL_STATE
```

Causes

The user (ID) who starts the CDC started task for the CDC Capture Agent does not have sufficient authorizations on the CDC metadata tables.

Resolving the problem

Make sure that the user who starts the CDC started task has the following authorizations on the `<CHCMetaID>.DMMD_SIGNALS` table:

- SELECT
- INSERT
- UPDATE
- DELETE

where `<CHCMetaID>` stands for the ID of the owner or the schema name of the CDC metadata tables (security identifier). You provided this ID when you ran the CDCMDMUT customization job.

UNLOAD utility threads remain in STOPPED state

You have started a load job (SYSPROC.ACCEL_LOAD_TABLES). You cancel the load job, or the job fails. As you display the status of the Db2 UNLOAD utility, you see many threads in the STOPPED state.

Symptoms

The UNLOAD utility threads associated with the load job are not ended. They remain in the STOPPED state.

Resolving the problem

You don't have to intervene. The UNLOAD utility threads are ended automatically when you start the next load job.

Appendix A. Mappings of product SQL codes to Db2 for z/OS SQL codes

When an error occurs on one of your accelerators or in the underlying Netezza database, the product generates an SQL code, which is then mapped to the closest Db2 SQL code. The codes and a message token are then returned to Db2. The message token usually contains a part of the information of the original message, but not all of it. The following table lists all mappings.

Table 49. Mappings of product SQL codes to Db2 for z/OS SQL codes

| Returned to Db2 | | | Error source | Remark | Introduced in product version or program temporary fix (PTF) |
|-----------------|---------|---|--|---|--|
| SQLSTATE | SQLCODE | Message token | | | |
| "02000" | 100 | Empty | <ul style="list-style-type: none"> Queries: N/A (end of file reached while reading from pipe) Data manipulation language (DML): SQLCODE 0 and no rows affected | Created by NZRDBManager <ul style="list-style-type: none"> fetch() until end of result set No rows affected by INSERT, UPDATE, or DELETE in executeStatement() expression | V2 |
| "00000" | 0 | Empty | | Various places in NZRDBManager and SQLApplicationManager | V2 |
| NZSTATE | NZCODE | A maximum of 70 bytes of the Netezza message | Netezza SQLSTATE "00xxx" or "01xxx"; Netezza SQL code >= 0 | | V2 |
| "58004" | -901 | A maximum of 63 bytes of the information in the Netezza SQLSTATE: | Netezza SQLSTATE "00xxx" or "01xxx"; Netezza SQL code < 0 | | V2 |
| "57011" | -904 | A maximum of 70 bytes of the Netezza message | Netezza SQLSTATE "08xxx" | Note: Also mapped to SQLCODE -904 and SQLSTATE "57011" including error tokens like "HYxxx". | |

Table 49. Mappings of product SQL codes to Db2 for z/OS SQL codes (continued)

| Returned to Db2 | | | Error source | Remark | Introduced in product version or program temporary fix (PTF) |
|-----------------|---------|---------------------------------------|--|--|--|
| SQLSTATE | SQLCODE | Message token | | | |
| "57014" | -952 | Empty | TaskCancelledException detected by accelerator | This error message is not returned in case the SQL statement was cancelled in Db2 (by a CAN -THREAD command or some other means). Such a Db2-side cancellation results in the closure of the DRDA connection, which is interpreted as a success by IBM Db2 Analytics Accelerator. (The statement execution on the accelerator was successful after all.) | V2 |
| "26501" | -514 | SQL_CURSOR | Cursor not prepared condition detected by accelerator | OPNQRY is chained, so if PRPSQLSTT fails to open, it will get this error. Note that PRPSQLSTT will return a SQLCA with the actual failure already. | V2 |
| "07001" | -313 | Empty | A condition where the number of host variables is not equal to the number of parameter markers was detected by the accelerator | can only occur on PRPSQLSTT | V2 |
| "56084" | -352 | String value of the position argument | Parameter marker SQL type mismatch condition detected by accelerator | V2 | |

Table 49. Mappings of product SQL codes to Db2 for z/OS SQL codes (continued)

| Returned to Db2 | | | Error source | Remark | Introduced in product version or program temporary fix (PTF) |
|-----------------|---------|---------------|---|--|--|
| SQLSTATE | SQLCODE | Message token | | | |
| "57012" | -30040 | Empty | Too many SQL statements already running | <p>Too many SQL statements are already running. The threshold is defined by the configuration parameter <code>MAXIMUM_NUMBER_CONCURRENT_RUNNING_QUERIES</code> and the <code>QueryGovernorDaemon</code> may adjust the value (only increasing it) based on the number of data slices of the Netezza backend.</p> <p>For such events we send DRDA message <code>RSCLMTRM</code>. It has no SQLCA associated, but Db2 still displays an error. The <code>SQLCODE</code> and <code>SQLSTATE</code> described here are the ones displayed by Db2 and we do store those in the SQL statement history. The SQL statement execution is rejected before any DRDA flow processing happens (after authentication).</p> | V2 |

Table 49. Mappings of product SQL codes to Db2 for z/OS SQL codes (continued)

| Returned to Db2 | | | Error source | Remark | Introduced in product version or program temporary fix (PTF) |
|-----------------|---------|--|--|---|--|
| SQLSTATE | SQLCODE | Message token | | | |
| "429CB" | -4747 | <p>One of the following:</p> <ul style="list-style-type: none"> Unsupported data type <i>type-name</i> Invalid CCSID <i>CCSID</i> Unsupported FOR BIT DATA column in <i>table-name</i> table (of type Unicode or ASCII) | <p>One of the following:</p> <ul style="list-style-type: none"> UnsupportedColumnDataTypeException InconsistentCCSIDInAcceleratorException UnsupportedForBitDataColumnInNonEBCDICTableException | <p>Only applicable to accelerator-only tables</p> | <p>V4 PTF5; not applicable before</p> |
| "56045" | -919 | Empty | TransactionMustRollbackException | <p>Only applicable to transactions with at least 1 DML/DDDL statement</p> | <p>V4 PTF5; not applicable before</p> |

Table 49. Mappings of product SQL codes to Db2 for z/OS SQL codes (continued)

| Returned to Db2 | | | Error source | Remark | Introduced in product version or program temporary fix (PTF) |
|-----------------|---------|---|---|--|--|
| SQLSTATE | SQLCODE | Message token | | | |
| "42601" | -104 | Found token in error; list of expected tokens | Syntax error condition detected by accelerator | Netezza error message text retrieved from SQLException and parsed to extract values for message tokens | V4 PTF5; was -904 or -901 before |
| "22007" | -181 | Empty | Invalid date, time, or datetime value | | |
| "42702" | -203 | Column name | Column is ambiguous condition detected by accelerator | | |
| "42704" | -204 | Table name | Table not found condition detected by accelerator. In connection with federated access support, this error might mean that a reference table or the original table that a reference table is pointing to cannot be found on the accelerator. | | |
| "42703" | -206 | Column name | Column not found condition detected by accelerator | | |
| "22018" | -420 | Internal Netezza function name, for example atoi | Conversion of string expression failed condition detected by accelerator | | |
| "42808" | -151 | Distribution key column (string constant) | Distribution key update detected by accelerator | | |
| "42721" | -725 | 1. Special register name 2. Special register value | Invalid special register setting condition detected by accelerator | | |

Table 49. Mappings of product SQL codes to Db2 for z/OS SQL codes (continued)

| Returned to Db2 | | | Error source | Remark | Introduced in product version or program temporary fix (PTF) |
|-----------------|---------|---|---|--|--|
| SQLSTATE | SQLCODE | Message token | | | |
| "22003" | -802 | <ol style="list-style-type: none"> 1. One of the following: <ul style="list-style-type: none"> • "OVERFLOW" • "OUT OF RANGE" • "EXPONENT OVERFLOW" 2. "ACCELERATOR" 3. "NUMERIC DATA" (all string constants) | Numeric overflow condition detected by accelerator | Netezza error message text retrieved from SQLException and parsed to extract values for message tokens | V4 PTF5; was -904 or -901 before |
| "22012" | -802 | <ol style="list-style-type: none"> 1. "ZERO DIVIDE" 2. "ACCELERATOR" 3. "NUMERIC DATA" (all string constants) | Divide by zero condition detected by accelerator | | |
| "40001" | -911 | <ol style="list-style-type: none"> 1. 0x00C9008E 2. 00001080 | Concurrent update of same row condition detected by accelerator | | |

Table 49. Mappings of product SQL codes to Db2 for z/OS SQL codes (continued)

| Returned to Db2 | | | Error source | Remark | Introduced in product version or program temporary fix (PTF) |
|-----------------|---------|---|--|---|--|
| SQLSTATE | SQLCODE | Message token | | | |
| "54010" | -670 | Column name | MaximumRowLengthLimit ExceededException or row length limit exceeded condition detected by accelerator | Applicable when creating accelerator-only tables, or when a query or DML statement requires temporary tables in Netezza database. | V4 PTF5; was generic -904 or -901 before |
| "57011" | -904 | 1. 0x00001080 2. 0x00E7000E 3. Resource name (60 bytes): Max 60 Bytes of IDAA Message | Internal product errors | Netezza error message text retrieved from SQL exception and parsed to extract values for message tokens. | V2 |

Table 49. Mappings of product SQL codes to Db2 for z/OS SQL codes (continued)

| Returned to Db2 | | | Error source | Remark | Introduced in product version or program temporary fix (PTF) |
|-----------------|---------|--|--------------------------|--|--|
| SQLSTATE | SQLCODE | Message token | | | |
| "57011" | -904 | <ol style="list-style-type: none"> 1. 0x00001080 2. 0x00E7000E 3. Resource name (60 bytes): Netezza SQLSTATE: Max 53 Bytes of Netezza Message | Netezza SQLSTATE HYxxxx | Catch-all for all Netezza errors that are not mapped to more specific SQL codes or SQL states Note: All such errors, if originating from Netezza, should be treated as defects so that a better error mapping can be found and implemented in IDAA. The following exceptions apply: <ul style="list-style-type: none"> • ERROR: SPU swap partition : Disk temporary work space is full – This error is raised by Netezza if an (intermediate) query result becomes too big and not enough temp disk storage is available. Db2 raises -904 in that situation as well. | V2 |
| "58004" | -901 | Netezza SQLSTATE:Max 63 Bytes of Netezza Message | All other Netezza errors | Catch-all for all Netezza errors that are not mapped to more specific SQL codes or SQLCODE/SQLSTATE Note: All such errors, if originating from Netezza, should be treated as defect so that a better error mapping can be found and implemented in IDAA. | V2 |

Appendix B. Impact of special register, ZPARM, or bind option settings on accelerator-only tables

SQL statements that reference accelerator-only tables can only be executed on an accelerator. However, certain combinations of special register and ZPARM settings might prohibit the execution of a statement on an accelerator. The same is true for the QUERYACCELERATION bind option for static SQL queries. The table in this section shows how these settings affect the statement execution.

Legend

The statement examples in [Table 50 on page 259](#) use abbreviations that indicate the type of a table:

AOT

Accelerator-only table

ACC

Regular accelerator table

Db2

Db2 table (not on accelerator)

Remember that the ZPARM setting QUERY_ACCEL_OPTIONS=2 enables INSERT . . . SELECT FROM . . . statements. With accelerator-only tables, the effect is often different from the effect it has in connection with regular accelerator tables. In many cases, the setting leads to an error. When applied successfully, it mostly leads to an acceleration of the INSERT portion of an INSERT . . . SELECT FROM . . . statement.

| <i>Table 50. Statement execution depending on the settings of CURRENT QUERY ACCELERATION, QUERY_ACCELERATION, or QUERYACCELERATION and QUERY_ACCEL_OPTIONS=2</i> | | | |
|--|--|-----------------------|----------------------|
| Statement | Special register SET CURRENT QUERY ACCELERATION= ZPARM QUERY_ACCELERATION= (ZPARM) Bind option QUERYACCELERATION= | QUERY_ACCEL_OPTIONS=2 | Statement execution |
| SELECT * FROM T1_AOT | NONE (1) | No | Error, reason code 2 |
| | ENABLE (2) ELIGIBLE (4) ALL (5) | No | Accelerator |
| SELECT * FROM T1_AOT, T5_ACC | NONE (1) | No | Error, reason code 2 |
| | ENABLE (2) ELIGIBLE (4) ALL (5) | No | Accelerator |

Table 50. Statement execution depending on the settings of CURRENT QUERY ACCELERATION, QUERY_ACCELERATION, or QUERYACCELERATION and QUERY_ACCEL_OPTIONS=2 (continued)

| Statement | Special register SET CURRENT QUERY ACCELERATION= ZPARM QUERY_ACCELERATION= (ZPARM) Bind option QUERYACCELERATION= | QUERY_ACCEL_OPTIONS=2 | Statement execution |
|---------------------------------------|--|-----------------------|----------------------------|
| SELECT * FROM T1_AOT, T3_Db2 | NONE (1) | No | Error, reason code 2 |
| | ENABLE (2) ELIGIBLE (4) ALL (5) | No | Error, reason code 12 |
| SELECT * FROM T5_ACC, T3_Db2 | NONE (1) | No | Db2 |
| | ALL (5) | No | Error, reason code 12 |
| | ELIGIBLE (4) | No | Db2 |
| | ENABLE (2) | No | Accelerator |
| INSERT INTO T1_AOT VALUES (...) | NONE (1) | No | Error, reason code 2 |
| | ENABLE (2) ELIGIBLE (4) ALL (5) | No | Accelerator |
| INSERT INTO T1_AOT SELECT FROM T2_AOT | NONE (1) | No | Error, reason code 2 |
| | | Yes | Error, reason code 2 |
| | ENABLE (2) ELIGIBLE (4) ALL (5) | No | INSERT portion accelerated |
| | | Yes | INSERT portion accelerated |
| INSERT INTO T1_AOT SELECT FROM T5_ACC | NONE (1) | No | Error, reason code 2 |
| | | Yes | Error, reason code 2 |
| | ENABLE (2) ELIGIBLE (4) ALL (5) | No | INSERT portion accelerated |
| | | Yes | INSERT portion accelerated |

Table 50. Statement execution depending on the settings of CURRENT QUERY ACCELERATION, QUERY_ACCELERATION, or QUERYACCELERATION and QUERY_ACCEL_OPTIONS=2 (continued)

| Statement | Special register SET CURRENT QUERY ACCELERATION= ZPARM QUERY_ACCELERATION= (ZPARM) Bind option QUERYACCELERATION= | QUERY_ACCEL_OPTIONS=2 | Statement execution |
|--|--|-----------------------|----------------------------|
| INSERT INTO T1_AOT SELECT FROM T3_Db2 | NONE (1) | No | Error, reason code 2 |
| | | Yes | Error, reason code 2 |
| | ENABLE (2) | No | Error, reason code 12 |
| | ELIGIBLE (4) ALL (5) | Yes | Error, reason code 12 |
| INSERT INTO T1_AOT SELECT FROM T2_AOT, T3_Db2, T5_ACC | NONE | No | Error, reason code 2 |
| | | Yes | Error, reason code 2 |
| | ENABLE (2) | No | Error, reason code 2 |
| | ELIGIBLE (4) ALL (5) | Yes | Error, reason code 12 |
| <ul style="list-style-type: none"> • INSERT INTO T5_ACC SELECT FROM T1_AOT • INSERT INTO T3_Db2 SELECT FROM T1_AOT | NONE (1) | No | Error, reason code 2 |
| | | Yes | Error, reason code 2 |
| | ENABLE (2) | No | SELECT portion accelerated |
| | ELIGIBLE (4) ALL (5) | Yes | SELECT portion accelerated |

Table 50. Statement execution depending on the settings of CURRENT QUERY ACCELERATION, QUERY_ACCELERATION, or QUERYACCELERATION and QUERY_ACCEL_OPTIONS=2 (continued)

| Statement | Special register SET CURRENT QUERY ACCELERATION= ZPARM QUERY_ACCELERATION= (ZPARM) Bind option QUERYACCELERATION= | QUERY_ACCEL_OPTIONS=2 | Statement execution | |
|--|--|-----------------------|--|-----------------------|
| <ul style="list-style-type: none"> • INSERT INTO T5_ACC SELECT FROM T5_ACC • INSERT INTO T3_Db2 SELECT FROM T5_ACC | NONE (1) | No | Db2 | |
| | | Yes | Db2 | |
| | ALL (5) | No | Error, reason code 17 | |
| | | Yes | SELECT portion accelerated | |
| | ELIGIBLE (4) | No | Db2 | |
| | | Yes | SELECT portion accelerated | |
| | ENABLE (2) | No | Db2 | |
| | | Yes | Entirely in Db2 or SELECT portion accelerated (based on estimated response-time reduction) | |
| | <ul style="list-style-type: none"> • INSERT INTO T5_ACC SELECT FROM T3_Db2 • INSERT INTO T3_Db2 SELECT FROM T3_Db2 | ALL (5) | No | Error, reason code 17 |
| | | | Yes | Error, reason code 12 |
| NONE (1) ENABLE (2) ELIGIBLE (4) | | No | Db2 | |
| | | Yes | Db2 | |
| <ul style="list-style-type: none"> • UPDATE T1_AOT (SELECT FROM T2_AOT) • UPDATE T1_AOT (SELECT FROM T5_ACC) • DELETE T1_AOT (SELECT FROM T2_AOT) • DELETE T1_AOT (SELECT FROM T5_ACC) | NONE (1) | No | Error, reason code 2 | |
| | ENABLE (2) ELIGIBLE (4) ALL (5) | No | Accelerator | |

Table 50. Statement execution depending on the settings of CURRENT QUERY ACCELERATION, QUERY_ACCELERATION, or QUERYACCELERATION and QUERY_ACCEL_OPTIONS=2 (continued)

| Statement | Special register SET CURRENT QUERY ACCELERATION= ZPARM QUERY_ACCELERATION= (ZPARM) Bind option QUERYACCELERATION= | QUERY_ACCEL_OPTIONS=2 | Statement execution |
|--|--|-----------------------|-----------------------|
| <ul style="list-style-type: none"> • UPDATE T1_AOT (SELECT FROM T3_Db2) • DELETE T1_AOT (SELECT FROM T3_Db2) | NONE (1) | No | Error, reason code 2 |
| | ENABLE (2) ELIGIBLE (4) ALL (5) | No | Error, reason code 12 |
| <ul style="list-style-type: none"> • UPDATE T5_ACC (SELECT FROM T1_AOT) • UPDATE T3_Db2 (SELECT FROM T1_AOT) • DELETE T5_ACC (SELECT FROM T1_AOT) • DELETE T3_Db2 (SELECT FROM T1_AOT) | NONE (1) | No | Error, reason code 22 |
| | ENABLE (2) ELIGIBLE (4) ALL (5) | No | Error, reason code 22 |

Notices

This information was developed for products and services offered in the US. This material might be available from IBM in other languages. However, you may be required to own a copy of the product or product version in that language in order to access it.

IBM may not offer the products, services, or features discussed in this document in other countries. Consult your local IBM representative for information on the products and services currently available in your area. Any reference to an IBM product, program, or service is not intended to state or imply that only that IBM product, program, or service may be used. Any functionally equivalent product, program, or service that does not infringe any IBM intellectual property right may be used instead. However, it is the user's responsibility to evaluate and verify the operation of any non-IBM product, program, or service.

IBM may have patents or pending patent applications covering subject matter described in this document. The furnishing of this document does not grant you any license to these patents. You can send license inquiries, in writing, to:

*IBM Director of Licensing
IBM Corporation
North Castle Drive, MD-NC119
Armonk, NY 10504-1785
US*

For license inquiries regarding double-byte character set (DBCS) information, contact the IBM Intellectual Property Department in your country or send inquiries, in writing, to:

*Intellectual Property Licensing
Legal and Intellectual Property Law
IBM Japan Ltd.
19-21, Nihonbashi-Hakozakicho, Chuo-ku
Tokyo 103-8510, Japan*

INTERNATIONAL BUSINESS MACHINES CORPORATION PROVIDES THIS PUBLICATION "AS IS" WITHOUT WARRANTY OF ANY KIND, EITHER EXPRESS OR IMPLIED, INCLUDING, BUT NOT LIMITED TO, THE IMPLIED WARRANTIES OF NON-INFRINGEMENT, MERCHANTABILITY OR FITNESS FOR A PARTICULAR PURPOSE. Some jurisdictions do not allow disclaimer of express or implied warranties in certain transactions, therefore, this statement may not apply to you.

This information could include technical inaccuracies or typographical errors. Changes are periodically made to the information herein; these changes will be incorporated in new editions of the publication. IBM may make improvements and/or changes in the product(s) and/or the program(s) described in this publication at any time without notice.

Any references in this information to non-IBM websites are provided for convenience only and do not in any manner serve as an endorsement of those websites. The materials at those websites are not part of the materials for this IBM product and use of those websites is at your own risk.

IBM may use or distribute any of the information you provide in any way it believes appropriate without incurring any obligation to you.

Licensees of this program who wish to have information about it for the purpose of enabling: (i) the exchange of information between independently created programs and other programs (including this one) and (ii) the mutual use of the information which has been exchanged, should contact:

*IBM Director of Licensing
IBM Corporation
North Castle Drive, MD-NC119
Armonk, NY 10504-1785
US*

Such information may be available, subject to appropriate terms and conditions, including in some cases, payment of a fee.

The licensed program described in this document and all licensed material available for it are provided by IBM under terms of the IBM Customer Agreement, IBM International Program License Agreement or any equivalent agreement between us.

The performance data and client examples cited are presented for illustrative purposes only. Actual performance results may vary depending on specific configurations and operating conditions.

Information concerning non-IBM products was obtained from the suppliers of those products, their published announcements or other publicly available sources. IBM has not tested those products and cannot confirm the accuracy of performance, compatibility or any other claims related to non-IBM products. Questions on the capabilities of non-IBM products should be addressed to the suppliers of those products.

Statements regarding IBM's future direction or intent are subject to change or withdrawal without notice, and represent goals and objectives only.

All IBM prices shown are IBM's suggested retail prices, are current and are subject to change without notice. Dealer prices may vary.

This information is for planning purposes only. The information herein is subject to change before the products described become available.

This information contains examples of data and reports used in daily business operations. To illustrate them as completely as possible, the examples include the names of individuals, companies, brands, and products. All of these names are fictitious and any similarity to actual people or business enterprises is entirely coincidental.

COPYRIGHT LICENSE:

This information contains sample application programs in source language, which illustrate programming techniques on various operating platforms. You may copy, modify, and distribute these sample programs in any form without payment to IBM, for the purposes of developing, using, marketing or distributing application programs conforming to the application programming interface for the operating platform for which the sample programs are written. These examples have not been thoroughly tested under all conditions. IBM, therefore, cannot guarantee or imply reliability, serviceability, or function of these programs. The sample programs are provided "AS IS", without warranty of any kind. IBM shall not be liable for any damages arising out of your use of the sample programs.

Each copy or any portion of these sample programs or any derivative work must include a copyright notice as follows:

© (your company name) (year).

Portions of this code are derived from IBM Corp. Sample Programs.

© Copyright IBM Corp. _enter the year or years_.

Trademarks

IBM, the IBM logo, and ibm.com are trademarks or registered trademarks of International Business Machines Corp., registered in many jurisdictions worldwide. Other product and service names might be trademarks of IBM or other companies. A current list of IBM trademarks is available on the web at "Copyright and trademark information" at www.ibm.com/legal/copytrade.shtml.

Java and all Java-based trademarks and logos are trademarks or registered trademarks of Oracle and/or its affiliates.



Linux is a trademark of Linus Torvalds in the United States, other countries, or both.

Microsoft and Windows are trademarks of Microsoft Corporation in the United States, other countries, or both.

Netezza and NPS are trademarks or registered trademarks of IBM International Group B.V., an IBM Company.

UNIX is a registered trademark of The Open Group in the United States and other countries.

Terms and conditions for product documentation

Permissions for the use of these publications are granted subject to the following terms and conditions.

Applicability

These terms and conditions are in addition to any terms of use for the IBM website.

Personal use

You may reproduce these publications for your personal, noncommercial use provided that all proprietary notices are preserved. You may not distribute, display or make derivative work of these publications, or any portion thereof, without the express consent of IBM.

Commercial use

You may reproduce, distribute and display these publications solely within your enterprise provided that all proprietary notices are preserved. You may not make derivative works of these publications, or reproduce, distribute or display these publications or any portion thereof outside your enterprise, without the express consent of IBM.

Rights

Except as expressly granted in this permission, no other permissions, licenses or rights are granted, either express or implied, to the publications or any information, data, software or other intellectual property contained therein.

IBM reserves the right to withdraw the permissions granted herein whenever, in its discretion, the use of the publications is detrimental to its interest or, as determined by IBM, the above instructions are not being properly followed.

You may not download, export or re-export this information except in full compliance with all applicable laws and regulations, including all United States export laws and regulations.

IBM MAKES NO GUARANTEE ABOUT THE CONTENT OF THESE PUBLICATIONS. THE PUBLICATIONS ARE PROVIDED "AS-IS" AND WITHOUT WARRANTY OF ANY KIND, EITHER EXPRESSED OR IMPLIED, INCLUDING BUT NOT LIMITED TO IMPLIED WARRANTIES OF MERCHANTABILITY, NON-INFRINGEMENT, AND FITNESS FOR A PARTICULAR PURPOSE.

GDPR considerations

For PID(s): 5697-DA7, 5697-DA5, 5697-DAB

Notice: This document is intended to help you in your preparations for GDPR readiness. It provides information about features of IBM Db2 Analytics Accelerator for z/OS that you can configure, and aspects of the product's use, that you should consider to help your organization with GDPR readiness. This information is not an exhaustive list, due to the many ways that clients can choose and configure features, and the large variety of ways that the product can be used in itself and with third-party applications and systems.

Clients are responsible for ensuring their own compliance with various laws and regulations, including the European Union General Data Protection Regulation. Clients are solely responsible for obtaining advice of competent legal counsel as to the identification and interpretation of any relevant laws and regulations that may affect the clients' business and any actions the clients may need to take to comply with such laws and regulations.

The products, services, and other capabilities described herein are not suitable for all client situations and may have restricted availability. IBM does not provide legal, accounting, or auditing advice or represent or warrant that its services or products will ensure that clients are in compliance with any law or regulation.

1. [GDPR Overview](#)
2. [“Product Configuration for GDPR” on page 270](#)
3. [“Data Life Cycle” on page 271](#)
4. [“Data Collection” on page 271](#)
5. [“Data Storage” on page 272](#)
6. [“Data Access” on page 272](#)
7. [“Data Processing” on page 272](#)
8. [“Data Deletion” on page 273](#)
9. [“Data Monitoring” on page 273](#)
10. [“Responding to Data Subject Rights” on page 273](#)

GDPR

General Data Protection Regulation (GDPR) has been adopted by the European Union (“EU”) and applies from May 25, 2018.

Why is GDPR important?

GDPR establishes a stronger data protection regulatory framework for processing of personal data of individuals. GDPR brings:

- New and enhanced rights for individuals
- Widened definition of personal data
- New obligations for processors
- Potential for significant financial penalties for non-compliance
- Compulsory data breach notification

Read more about GDPR

- EU GDPR Information Portal (<https://www.eugdpr.org/>)
- [ibm.com®/GDPR website \(https://ibm.com/GDPR\)](https://ibm.com/GDPR)

The EU General Data Protection Regulation (GDPR) regulates data privacy in the European Union (EU). For details, see: <https://www.eugdpr.org>

The regulations laid out in the GDPR apply if the data controller (an organization that collects data from EU residents), or the processor (an organization that processes data on behalf of a data controller, such as a cloud service provider), or the data subject (an individual) is based in the EU (source: Wikipedia. See: https://en.wikipedia.org/wiki/General_Data_Protection_Regulation). A violation of GDPR regulations might incur severe financial penalties (fines) and reputation damages. This documentation is intended for data controllers or processors who use Db2 for z/OS together with IBM Db2 Analytics Accelerator for z/OS with the aim of storing personal data of EU residents (individuals). As regards IBM Db2 Analytics Accelerator for z/OS, the IBM company is neither the data controller, nor the data processor. Nevertheless, the IBM company feels obliged to give such entities guidance on how to follow GDPR regulations.

Your responsibilities as a data controller or processor

If you act on behalf of a data controller or data processor, see the frequently asked questions (FAQ) on the official GDPR website to find out what your responsibilities are:

<https://www.eugdpr.org/gdpr-faqs.html>

Furthermore, refer to chapter 4 in the GDPR regulations:

<https://www.eugdpr.org/article-summaries.html>

Product Configuration for GDPR

The following sections provide considerations for configuring IBM Db2 Analytics Accelerator for z/OS to help your organization with GDPR readiness.

How to configure the offering so that it can be used in a GDPR environment

The following sections describe how personal data is stored and processed by IBM Db2 Analytics Accelerator for z/OS (called 'accelerator' in the text that follows).

If personal data is to be stored on an accelerator, the following configuration steps might help you meet your compliance objectives with regard to GDPR:

- Activate the encryption of data in motion (data that is transferred over a data network between Db2 for z/OS and the accelerator).
- Activate the encryption of data at rest (encryption of disks and other storage devices).
- Do not share passwords for the operation of the IBM Db2 Analytics Accelerator Console between multiple persons. Instead, create separate user IDs with different passwords for each console user.
- Give read access to personal data (the privilege to run queries) only to authorized Db2 for z/OS users. To this end, define appropriate Db2 authorizations (SELECT, and so on) in the Db2 for z/OS catalog.
- Restrict the right to unload data from and to create image copies in Db2 for z/OS. Give this right to authorized administrators only.
- Restrict access to the 'Save Trace' function in Db2 Analytics Accelerator for z/OS because the collected trace data might contain personal data. Access should be given to authorized administrators only.
- Restrict access to the table SYSIBM.USERNAMES in the catalog of the Db2 for z/OS communication database because this table contains authentication credentials. If these credentials are read or copied by unauthorized users, these users might obtain access to sensitive personal data.

Data Life Cycle

You can create copies of any Db2 for z/OS table on an accelerator (accelerator-shadow tables). As soon as you create a copy of a Db2 for z/OS table and load it with personal data, the GDPR regulations apply in the same way as they apply to personal data in the original Db2 for z/OS tables.

An accelerator also allows you to load and store external data outside of Db2 for z/OS, such as the data of VSAM files, in accelerator-shadow tables. Products like the Db2 Analytics Accelerator Loader can be used to this end. If the external data contains personal information, the GDPR regulations apply to the data that is transferred to the accelerator.

What types of data?

The administrative environment of an accelerator (client and configuration software) does not store personal data, except for the user IDs and authentication tokens of its administrators. However, the GDPR regulations apply to all personal data that you store in database tables on the accelerator.

Where in the process?

An accelerator is loaded with data in the course of individual load operations or by the incremental update function (automated load of table updates). Adding a table to an accelerator does not yet copy any data. It merely defines the table's structure (metadata) on the accelerator. However, if you load the table or enable it for incremental updates, the data of the source table - which might contain personal data - is copied to the accelerator.

For what purpose?

An accelerator, like Db2 for z/OS, is a general database management system for SQL queries. Such queries are run with the aim of retrieving stored information and gaining further insights (analytical queries that uncover the dependencies or connections between sets of values). An accelerator can return the results of SQL queries to authorized and authenticated users of the system. The results usually consist of subsets or aggregations of numerous data records. All these records might include personal data.

Personal data used for online contact with IBM

IBM Db2 Analytics Accelerator for z/OS clients can submit online comments/feedback/requests to contact IBM about accelerator subjects in a variety of ways, primarily:

- Public comments area on pages in the IBM Integration community on IBM developerWorks®
- Public comments area on pages of the IBM Db2 Analytics Accelerator for z/OS product documentation in the IBM Knowledge Center
- Feedback forms in the IBM Integration community

Typically, only the client name and email address are used, to enable personal replies for the subject of the contact, and the use of personal data conforms to the *IBM Online Privacy Statement* (<https://www.ibm.com/privacy/cc/>).

Data Collection

IBM Db2 Analytics Accelerator for z/OS can be used to collect personal data. When assessing your use of IBM Db2 Analytics Accelerator for z/OS and the requirements of GDPR, you should consider the types of personal data which in your circumstances are stored on an accelerator.

The use of an accelerator does not impose new requirements for the collection of personal data. It does not introduce new users or new privileges, but makes use of existing users and their privileges as defined in Db2 for z/OS. The use of an accelerator does not introduce additional obligations for the safekeeping or administration of data if you already observe the GDPR regulations for the storage of data in Db2 for z/OS.

Make sure that the process of collecting data and storing it in Db2 for z/OS is GDPR-compliant. The use of an accelerator will then be equally compliant.

Data Storage

The use of IBM Db2 Analytics Accelerator for z/OS involves the storage of data in a persistent manner.

An accelerator is a general-purpose data processing and retrieval engine. It is not aware of the meaning of data or any meaning that can be inferred from it. It is thus the responsibility of the data controller or processor to classify the data as personal data - for example account data - and make sure that the collection, access and processing of this data is in accordance with the GDPR regulations.

Storage in backups:

An accelerator has no backup function. However, image copies are created in Db2 for z/OS when the accelerator's archiving function is used (high performance storage saver). If these image copies contain personal data, the GDPR rules apply. This means, for example, that if individuals request their data to be deleted, it must also be deleted from all the image copies that may exist.

Storage in archives:

The high performance storage saver deletes table data from Db2 for z/OS and stores it exclusively on an accelerator. If this data contains personal information, the GDPR regulations might require that you delete the personal information from a number of records. The current version of the accelerator software does not allow DELETE operations on archived partitions. So in case you must delete records, first restore the archived partition to Db2 for z/OS, then delete then delete the personal data from Db2 for z/OS. Finally, archive the partition again (which now does not include the personal data anymore).

Data Access

Access to data on an accelerator requires a Db2 for z/OS user ID and a password. The accelerator recognizes the privileges defined in Db2 for z/OS and does not allow a user to run functions that she or he is not entitled to use.

As long as the Db2 for z/OS authorizations, such as SELECT, INSERT, UPDATE, or DELETE privileges, are defined in accordance with the GDPR regulations, access to data on the accelerator will likewise be in accordance with these regulations.

So it is crucial that the definition of roles and access rights in Db2 for z/OS effectuates an adequate separation of duties and responsibilities.

One accelerator-specific function might provide access to personal data on the accelerator: This is the "Save Trace" function, which collects diagnostic information for troubleshooting. The resulting trace files might contain personal data because they sometimes include the code of SQL queries to which personal information has been passed in the form of query literals. Trace files can also include memory dumps that contain personal data.

It is therefore important that access privileges to data, such as SELECT privileges or superuser privileges like SYSADM and DBADM, are granted with great care. The permission to use the "Save Trace" function should be given to selected administrators only.

The privilege to create image copies in Db2 for z/OS must also be handled with care. It is required, for example, if a user wants to archive table partitions on an accelerator.

Data Processing

Privileges defined in the Db2 for z/OS catalog control data processing on an accelerator.

In addition to that, the encryption features (encryption of data in motion and encryption of data at rest) should be activated. This prevents an unauthorized person without proper privileges from gaining direct access to personal data by interfering with the network communication or by obtaining physical access to the storage devices (hard disks or solid state disks).

Encryption features and safeguarding precautions:

Encryption of data in motion:

This feature encrypts the network traffic between an IBM Z system and an accelerator.

Encryption of data at rest:

This feature encrypts the data on an accelerator's physical storage devices (hard disks and solid state disks). Depending on the model of the hardware, the feature might already be turned on by default.

Encryption key ownership:

Restrict access to the encryption keys because the keys enable a person to read or decrypt personal data on a network or storage device. Put the safekeeping and maintenance (rotation) of the encryption keys in the hands of a trusted administrator.

Data Deletion

When data is deleted from Db2 for z/OS, it might still exist in table copies on the accelerator. To delete the data on an accelerator, you have the following options:

The data in accelerator-shadow tables is deleted:

- If the data in the original Db2 for z/OS tables has been deleted, and if the affected accelerator-shadow tables have been reloaded (with the contents of the now empty Db2 tables).
- If the accelerator-shadow tables are removed from the accelerator.
- If the incremental update function is used and the function replicates empty table content to the accelerator because the original Db2 for z/OS table data has been deleted.

The data in an accelerator-only table (AOT) is deleted:

- If the AOT is removed from the accelerator.
- If an explicit DELETE statement is submitted on the Db2 for z/OS side, which references the AOT and contains a predicate that specifies the row to be deleted.

The data in partitions archived by the High Performance Storage Saver is deleted:

- If the table partitions are removed from the accelerator.
- If an archived partition is restored to Db2 for z/OS.
- If the data is deleted from Db2 for z/OS because this means that the archived partition is reloaded or that the partition is archived again after the deletion from Db2 for z/OS (empty table content will be reloaded or archived).

Data Monitoring

Db2 for z/OS provides powerful auditing and monitoring functions that allow you to track the processing of personal data. Because IBM Db2 Analytics Accelerator for z/OS is a logical component of Db2 for z/OS, and keeps only copies of Db2 for z/OS data, the monitoring functions for data processing in Db2 for z/OS are sufficient.

Responding to Data Subject Rights

To identify an individual's data that is stored on an accelerator, you can submit SQL queries from Db2 for z/OS. These queries ought to search for the name, the account number, or for other identifying information about the subject using SQL syntax. Since an accelerator works on copies of Db2 for z/OS data, the same queries can be run to retrieve the data either from Db2 for z/OS or from the accelerator. Specific advice or examples of such queries can not be provided here because the structure and the content of the database tables, as defined by the data controller or data processor, is not known.

Does the offering facilitate being able to meet data subject rights?

Right to Access

Can the client provide individuals access to their data?

Db2 for z/OS and accelerators can process SQL queries in which an individual's ID can be specified as a search criterion. This way, all data stored about that individual can be retrieved. In Db2 for z/OS,

a client's data access can be restricted, so that the client can only search and retrieve a subset of the available data records, that is, those records that belong to a specific group of individuals. To this end, a feature called label based access control (LBAC) can be employed. IBM Db2 Analytics Accelerator provides a similar functionality, which restricts access to a selected set of rows based on the CURRENT SQLID special register.

Can the client provide individuals information about what data the client has about the individual?

Yes. To identify an individual's data stored on an accelerator, the client can submit SQL queries from Db2 for z/OS. These queries ought to search for the name, the account number, or for other identifying information about the subject using SQL syntax.

Right to Modify

Can the client allow an individual to modify or correct their data?

Db2 for z/OS allows a client to update the data that is stored about an individual. Depending on the architecture of the application, it might even be possible to authorize the individuals, so that these can update their data by themselves. After an update in Db2 for z/OS, the modified data is copied to the accelerators attached to the database during the next reload operation, which can be started manually or automatically (by the incremental update function). During that process, incorrect data will be overwritten.

Can the client correct an individual's data for them?

Yes (see the previous question *Can the client allow an individual to modify or correct their data?*).

Right to Restrict Processing

Can the client stop processing an individual's data?

Yes. In Db2 for z/OS, a client can submit DELETE statements to remove data records of individuals. The removal will be reflected in the data that is stored on an attached accelerator when the next reload operation (manual or automatic) is taking place. During that process, records previously deleted from Db2 for z/OS will also be deleted from the accelerator. Furthermore, an individual's data can be excluded from SQL queries through the use of filters in query predicates. For example, a query that reads `SELECT CUSTOMER_DATA FROM CUSTOMER_TABLE where custid NOT IN (a, b, . . . c)` returns only data records that are not related to (do not belong to) the users in the specified group (a, b, . . . c).

Right to Object

Same as [“Right to Restrict Processing”](#) on page 274.

Right to Be Forgotten

Can the client delete an individual's data?

Yes.

Right to Data Portability

Can the customer provide an individual with the information that they have about the individual in a user-friendly/machine readable format?

Yes.

Glossary

This glossary includes terms and definitions for IBM Db2 Analytics Accelerator for z/OS.

The following cross-references are used in this glossary:

- *See* refers you from a term to a preferred synonym, or from an acronym or abbreviation to the defined full form.
- *See also* refers you to a related or contrasting term.

To view glossaries for other IBM products, go to www.ibm.com/software/globalization/terminology (opens in new window).

A

accelerator-archive table

A table on an accelerator that contains data archived by the High Performance Storage Saver. The data in an accelerator-archive table comes from a DB2 table. The original DB2 data is deleted during the archiving process, so that storage space is freed in Db2 for z/OS. The High Performance Storage Saver is typically used for historical Db2 data that is no longer actively queried and maintained. It is none the less possible to include the data in accelerator-archive tables in accelerated queries. To archive a Db2 table or partitions of this table with the High Performance Storage Saver, the table must exist as an accelerator-shadow table. However, the tables does not have to be loaded.

accelerator-shadow table

A table on an accelerator whose definition is derived from a Db2 for z/OS table and that can be used for accelerated queries after loading (copying data from the original DB2 table to the accelerator-shadow table).

access plan graph

A visual representation of a query that shows the database objects that are accessed by the query and the order in which this is done.

APF

See [authorized program facility](#).

authorized program facility (APF)

In a z/OS environment, a facility that permits the identification of programs that are authorized to use restricted functions.

C

cluster

- Number of configured accelerators.
- Table rows that are grouped together because they have the same value in a particular column.

colocated join

A join method where columns of an accelerator-shadow table must be on the same processing node. Leads to shorter query response times.

coordinator node

The active Netezza host.

D

data slice

A portion of an accelerator-shadow table that is processed by a worker node.

DDF

See distributed data facility (DDF).

distributed data facility (DDF)

A set of DB2 for z/OS components by which Db2 for z/OS communicates with another relational database management system.

Dynamic Statement Cache

A pool in which DB2 saves prepared SQL statements that can be shared among different threads, plans, and packages. By sharing these statements, applications can avoid unnecessary preparation processes and thus improve performance.

F

fact table

A database table, commonly located at the center of a star schema surrounded by dimension tables, that contains measures of a business process, and foreign keys from the dimension tables.

failback

An automatic operation that returns the processing of a query to Db2 for z/OS if an error occurs while the query is processed by an accelerator.

friendly arithmetic

When an exception, such as a buffer overflow, a division by zero, or an out-of-range value occurs, DB2 returns the value NULL combined with a +802 warning, provided that the faulty expression is in the outermost SELECT statement and affects only one row.

I

inhouse processing

A query is processed by Db2 for z/OS and not routed to an accelerator.

L

lock

A means of preventing uncommitted changes made by one application process from being perceived by another application process and for preventing one application process from updating data that is being accessed by another process. A lock ensures the integrity of data by preventing concurrent users from accessing inconsistent data.

M

manifest

An XML file that contains metadata and procedural instructions for an IBM Db2 Analytics Accelerator for z/OS update package, such as the version of the package, update information (which versions are updated to which newer version), and parameters for internal package processing.

P

plan (also execution plan)

A Netezza file with an extension of pln that shows in which order the tables in a query are scanned.

port-forwarding

A networking mechanism that allows Secure Shell access to a host in a private network from the outside.

Q

query conversion

Db2 for z/OS and the query engine of IBM Db2 Analytics Accelerator for z/OS handle certain SQL expressions differently. In some cases, IBM Db2 Analytics Accelerator for z/OS does not support an SQL expression that is supported by Db2 for z/OS. Therefore, changes to the mode of processing are sometimes inevitable when a query is routed to an accelerator.

R

row

See [table row](#).

rowset

A set of rows for which a cursor position is established.

S

Secure Shell (SSH)

A UNIX-based command interface and protocol for securely getting access to a remote computer.

S-FTP

See [SSH File Transfer Protocol](#).

skew

An imbalanced distribution of table rows among Netezza processing nodes.

Sockets Secure (SOCKS)

A client/server architecture that transports TCP/IP traffic through a secure gateway. A SOCKS server performs many of the same services that a proxy server does.

SOCKS

See [Sockets Secure](#).

SSH File Transfer Protocol

A network protocol that provides the ability to transfer files securely over any reliable data stream.

SSH tunnel

A secure and encrypted path through a network.

SSH

See [Secure Shell](#).

systems programmer

A programmer who plans, maintains, and controls the use of an operating system with the aim of improving the overall productivity of an installation.

T

table row (row)

The horizontal component of a table, consisting of a sequence of values, one for each column of the table.

table space

- A logical unit of storage in a database. In DB2 for z/OS, a table space is a page set and can contain one or more tables.
- In Netezza terminology, a logical collection of extents that are assigned to a table. A table space contains all the disk space that is allocated to a given table or table fragment and includes pages allocated to data and to indexes, pages that store TEXT or BYTE data in the dbspace, and bitmap pages that track page use within the extents.

temporary table

A table that holds temporary data. Temporary tables are useful for holding or sorting intermediate results from queries that contain many rows. The two kinds of temporary tables, which are created by different SQL statements, are the created temporary table and the declared temporary table.

throughput

A measure of the amount of information transmitted over a network in a given period of time. Throughput is generally measured in bits per second (bps), kilobits per second (Kbps), or megabits per second (Mbps).

V

virtual IP address

An IP address that is shared among multiple domain names or multiple servers. Virtual IP addressing enables one IP address to be used either when insufficient IP addresses are available or as a means to balance traffic to multiple servers.

W

wall IP address

A Netezza term for the virtual IP address that is used to contact the Netezza system over the network. A floating IP address that is automatically assigned to the active Netezza host. Using the wall IP address from the z/OS data server, the active Netezza host can always be reached. This is transparent behavior in case of a failover.

WLM application environment

A z/OS Workload Manager attribute that is associated with one or more procedures. The WLM application environment determines the address space in which a given procedure runs.

Index

Special Characters

<CHCMetaID>.DMMD_SIGNALS table [247](#)

Numerics

24:00:00 [41](#), [46](#), [225](#)

A

About section, Accelerator view [64](#)

accelerating static SQL queries

bind option [7](#)

bind options [23](#)

preparing tables [110](#)

acceleration conditions [21](#)

accelerator

adding to configuration [99](#)

canceling tasks [151](#)

defining [99](#)

maintenance [229](#)

monitoring

accelerators [165](#)

usage metrics [165](#)

repair [229](#)

start [108](#)

status [107](#)

stop [109](#)

update [209](#)

usage metrics [165](#)

view encryption status [227](#)

Accelerator view

About section [64](#)

Diagnostics section [79](#)

header [64](#)

Monitoring section [64](#), [79](#)

Queries section [79](#)

Queries tab [138](#)

Query Monitoring section [64](#), [141](#)

Query monitoring section, columns [138](#)

refresh interval [171](#)

regular accelerators [64](#)

Replication section [79](#)

Tables section [64](#)

virtual accelerators [75](#)

z/OS section [79](#)

accelerator-archive tables [15](#)

accelerator-only tables

bind option for static SQL [23](#)

dynamic SQL queries against [21](#)

loading [112](#)

restrictions [49](#)

special register settings [21](#)

static SQL queries against [23](#)

accelerator-shadow tables

removing [5](#)

accelerators

accelerators (*continued*)

adding [1](#)

basic concepts [7](#)

networking details [104](#)

removing [154](#)

updating software [209](#)

access plan graph

displaying [133](#)

example [8](#)

nodes [134](#)

Access Server

installing updates [210](#)

update packages [211](#)

access, Db2 subsystem [91](#)

accessibility features for this product [xvii](#)

activation of software updates

switching between software versions [213](#)

add

columns to Db2 for z/OS table

[124](#)

Add Tables wizard [104](#)

adding

accelerators [1](#)

virtual accelerators [103](#)

administration client

IBM Data Server Manager [57](#), [77](#)

IBM Db2 Analytics Accelerator Studio [57](#), [58](#)

updating [222](#)

Administration Explorer

folders [58](#)

menus [58](#)

aggregate SQL functions [31](#)

aliases [55](#)

ALTER

TABLE, required actions [187](#)

TABLESPACE, required actions [187](#)

ALTER TABLE operation, incremental update function [178](#)

analyze queries [129](#)

archive

partition data [190](#)

table data [190](#)

archived partition (data), restoring [196](#)

array data type [55](#)

ASCII [27](#)

authentication [99](#)

automatic notifications and creation of support cases [231](#)

B

balancing the workload [110](#)

basic concepts

accelerators [7](#)

access plan graph [8](#)

distribution keys [11](#)

organizing keys [12](#)

selecting tables for query acceleration [8](#)

system table entries [20](#)

basic concepts (*continued*)

- tables [8](#)
- unsupported data types [8](#)
- virtual accelerators [7](#)
- zone maps [13](#)

best practices

- distribution keys [11](#)
- organizing keys [12](#)

bind options for accelerating static SQL queries

- GETACCELARCHIVE [23](#)
- QUERYACCELERATION [23](#), [259](#)

broadcast [2](#)

buffer overflow [41](#)

C

call-home function [231](#)

cancel

- tasks [151](#)

CAST specification [31](#)

CCSID

- 1200 [27](#)
- 1208 [27](#)
- 367 [27](#)
- 37 [27](#)
- 819 [27](#)
- ASCII [27](#)
- EBCDIC [27](#)
- UNICODE [27](#)

CDC

- event messages [231](#)
- signals table, authorizations [247](#)
- troubleshooting [247](#)

changing

- adding columns to table [124](#)
- distribution key [120](#)
- organization keys [120](#)
- table schema [124](#)

CHAR (n) [41](#)

clear trace information [164](#)

coded character set identifier, *See* CCSID

CODEUNITS16 [31](#)

CODEUNITS32 [31](#)

collating sequences (sort orders) [41](#)

columns added to Db2 for z/OS [124](#)

conditions

- query routing to an accelerator [26](#)

conditions for query acceleration [21](#)

configuration, trace behavior [155](#)

configure tracing [64](#), [79](#), [155](#)

configuring new

- adding [1](#)

connection

- data server [1](#)
- database [1](#)
- database server [95](#)
- profile [91](#)

connection profile [1](#)

conversion

- REAL to DOUBLE [27](#)

correlated subqueries [41](#)

COUNT__BIG [41](#)

create objects in connected databases [126](#)

create reference tables [202](#)

create referencing accelerator-only tables [202](#)

creating support cases [231](#)

credentials [99](#)

CURRENT GET_ACCEL_ARCHIVE [194](#)

CURRENT QUERY ACCELERATION [194](#), [259](#)

CURRENT QUERY ACCELERATION special register [21](#)

D

data consistency [40](#)

data loss, incremental update function [178](#)

data privacy [269](#)

data sharing group [60](#), [64](#), [79](#), [112](#)

data slices [7](#)

data types

- Db2 for z/OS [27](#)

- Netezza [27](#)

- ranges [27](#)

- supported [27](#)

- unsupported [27](#)

database connection profile [1](#), [91](#)

database request modules [26](#)

database server

- connection [95](#)

- exploring [98](#)

date

- format [47](#)

DATE(numeric_exp) [47](#)

Db2 10 for z/OS, incompatibilities [52](#)

Db2 11 for z/OS

- aliases [55](#)

- array data type [55](#)

- global variables [55](#)

- grouping sets [55](#)

- named memory variables [55](#)

- new features [55](#)

- supergroups [55](#)

- synonyms [55](#)

Db2 11 for z/OS, RBA and LRSN conversion and storage saver [198](#)

Db2 Dynamic Statement Cache [21](#)

DBCS [43](#)

DECLARE CURSOR [26](#)

defining

- accelerator-shadow tables [104](#)

- data [2](#)

delete trace information [64](#), [79](#), [164](#)

diagnostic information [155](#)

distributing the workload to multiple accelerators [20](#)

distribution keys

- best practices [11](#)

- changing [120](#)

- impact

- join performance [11](#)

- query acceleration [11](#)

- overview [2](#)

- specifying [120](#)

division by zero [41](#)

DNS_QUERYINFO_TABLE [129](#)

DOUBLE [56](#)

double-byte data [43](#)

DRDA [26](#)

DSNX881I messages

- structure of [231](#)

DSNX881I messages (*continued*)
SYSLOG [231](#)

E

EBCDIC [27](#), [43](#)
encryption
 view status [227](#)
enhancements in this version [xv](#)
environment variables
 AQT_HOST_PACKAGE_DIRECTORY [210](#), [211](#), [217](#)
European Union (EU) [269](#)
evaluation, predicate [44](#)
event viewer [183](#)
event viewer for incremental updates [183](#)
exceptions [43](#)
EXPLAIN
 function [7](#)
 information [7](#), [129](#)
 tables [129](#)
 tables, creating [129](#)
exploring a database server [98](#)
export of table specifications [153](#)

F

FAILBACK processing
 overview [21](#)
 restrictions [21](#)
federated access
 create reference tables [202](#)
 create referencing accelerator-only tables [202](#)
 grant access to Db2 subsystem [201](#)
 grant access to remote tables [201](#)
 remove reference tables [205](#), [207](#)
 remove referencing accelerator-only tables [205](#), [207](#)
 revoke access [205](#)
federation [198](#), [201](#), [202](#), [205](#), [207](#)
firewall [235](#)
FLOAT [41](#), [56](#)
floating-point error tolerance [56](#)
format
 date [47](#)
 time [47](#)
FTP server configuration for Save Trace function [163](#)

G

GB18030 characters, incremental update function [178](#)
GDPR [269](#)
General Data Protection Regulation, *See* GDPR
GET_ACCEL_ARCHIVE [194](#)
GETACCELARCHIVE [23](#)
global variables [55](#)
glossary [275](#)
grant access
 to remote Db2 subsystem [201](#)
 to remote tables [201](#)
grouping sets [55](#)
GUI elements
 IBM Data Server Manager [77](#)
 IBM Db2 Analytics Accelerator Studio [58](#)

H

hash partitioning [11](#)
header, Accelerator view [64](#)
health, system [231](#)
heartbeat [231](#)
HFP [56](#)
High Performance Storage Saver
 RBA conversion from 6-byte to 10-byte, Db2 11 for z/OS
 [198](#)
 restoring partition data [196](#)
 See also storage saver
HTAP [172](#)
Hybrid Transactional Analytical Processing (HTAP), *See*
WAITFORDATA

I

IBM Data Server Manager
 list of queries [88](#)
 list of tables [85](#)
 main menu [78](#)
 updating [222](#), [224](#)
IBM Db2 Analytics Accelerator for
 z/OS
 Console [99](#)
 installing updates [210](#)
 update packages [211](#)
 updates, installing [209](#)
IBM Db2 Analytics Accelerator Studio
 language settings [223](#)
 main menu [58](#)
 perspective in IBM Data Studio [223](#)
 updating [222](#)
 workspace directory [223](#)
IBM Db2 Analytics Accelerator StudioIBM Data Server
Manager [57](#)
IBM InfoSphere Change Data Capture for z/OS [231](#)
 See also CDC
IBM Netezza Analytics [128](#)
ibmdbR [128](#)
IDT, *See* in-database transformation
IEEE754 [56](#)
importing table specifications [154](#)
improvements in this version [xv](#)
in-database transformation [16](#)
incompatibilities [41](#), [48](#)
incremental updates
 ALTER TABLE operation [178](#)
 data loss [178](#)
 description [172](#)
 event log [164](#)
 event messages [231](#)
 excluding tables (disabling) [178](#)
 GB18030 characters [178](#)
 including tables (enabling tables for) [178](#), [247](#)
 incompatibilities [48](#)
 monitoring [182](#)
 REORG [178](#)
 ROTATE PARTITION [178](#)
 start [177](#)
 stop [177](#)
 use cases [172](#)
 using the event viewer [183](#)

incremental updates (*continued*)

 WAITFORDATA [173](#)

 warnings [185](#)

inhouse query processing [21](#)

installation, updates [209](#)

interface elements

 Administration Explorer [58](#)

 IBM Data Server Manager [77, 78](#)

 IBM Db2 Analytics Accelerator Studio [58](#)

interface elements IBM Db2 Analytics Accelerator Studio [58](#)

introduction [1](#)

isolation levels [40](#)

L

language settings, IBM Db2 Analytics Accelerator Studio [223](#)

LEFT [44](#)

length, rows [44](#)

list of queries, IBM Data Server Manager [88](#)

list of tables, IBM Data Server Manager [85](#)

list tasks [151](#)

load data [4](#)

loadaccelerator-only tables

 tables [112](#)

LOBVALA [244](#)

LOCATE [44](#)

LOCATE_IN_STRING [45](#)

location name [101](#)

log record sequence number, *See* LRSN

loss of data, incremental update function [178](#)

LOWER [45](#)

LRSN conversion from 6-byte to 10-byte in Db2 11 for z/OS [198](#)

M

main menu

 IBM Data Server Manager [78](#)

 IBM Db2 Analytics Accelerator Studio [58](#)

maintenance [229](#)

mapping

 Netezza states to Db2 SQL code [249](#)

maximum row length of tables [41](#)

MBCS [43](#)

MEDIAN function [31](#)

mixed data [43](#)

modification of connected databases [126](#)

monitoring [182](#)

monitoring accelerators [165](#)

monitoring incremental updates [182](#)

Monitoring section, Accelerator view [64, 79](#)

monitoring view

 accelerator [170](#)

MONTHS_BETWEEN [45](#)

moved

 partitions [15](#)

 tables [15](#)

multibyte data [43](#)

N

named memory variables [55](#)

Netezza error codes [249](#)

Netezza Firmware (FDT)

 installing updates [218](#)

 transferring updates [217](#)

 updating [216](#)

Netezza Host Platform (HPF)

 installing updates [218](#)

 transferring updates [217](#)

 updating [216](#)

Netezza host software, transferring update [64, 79](#)

Netezza Platform Software (NPS)

 installing updates [210](#)

 update packages [211](#)

networking details [104](#)

new features [xv](#)

new features in Db2 10 for z/OS [52](#)

NEXT_DAY [46](#)

NPS, *See* Netezza server software

O

object list editor

 monitoring view [170](#)

Object List Editor [60](#)

OCTETS [31](#)

organizing keys

 best practices [12](#)

 changing [120](#)

 overview [2](#)

 specifying [120](#)

 table size [12](#)

out-of-range values [41](#)

overview, tasks [91](#)

P

pairing code [99](#)

parameter markers [43](#)

partition (data), restoring [196](#)

perspective, IBM Db2 Analytics Accelerator Studio [223](#)

PMR, *See* support case

port-forwarding [218](#)

ports [235](#)

precision of timestamp [52](#)

predicate evaluation [41, 44](#)

preferences [171](#)

privacy, *See* data privacy

process flow [5](#)

product administration [57](#)

Q

queries

 IBM Data Server Manager [88](#)

queries, running [126](#)

query

 evaluation [8](#)

 matching [8](#)

 redirection [8](#)

 visual representation [133](#)

query acceleration

 disabling [4, 119](#)

 enabling [4](#)

 enabling tables [117](#)

- query acceleration (*continued*)
 - reason codes [129](#)
 - selecting tables [8](#)
- query history [244](#)
- query monitoring
 - columns [138](#)
- Query Monitoring section in Accelerator view [244](#)
- Query Monitoring section, Accelerator view [64](#)
- query routing to an accelerator
 - conditions [21](#), [26](#)
 - configuration [21](#)
 - floating-point error tolerance [56](#)
 - incompatibilities [41](#)
 - isolation levels [40](#)
 - restrictions
 - result data types [37](#)
 - special registers [37](#)
 - subtypes [37](#)
 - result data types [37](#)
 - supported queries [26](#)
 - supported special registers [35](#)
 - supported SQL functions [31](#)
- query routing to an accelerator, incompatibilities with Db2
 - 10 for z/OS [52](#)
- QUERY_ACCEL_OPTION [259](#)
- QUERY_ACCELERATION [259](#)
- QUERY_ACCELERATION_ZPARAM [21](#)
- QUERYACCELERATION [23](#), [259](#)

R

- R programming language, support for [128](#)
- random distribution [2](#), [11](#)
- RBA conversion from 6-byte to 10-byte in Db2 11 for z/OS [198](#)
- REAL [56](#)
- REAL-to-DOUBLE conversion [27](#)
- reason code [259](#)
- reason codes [129](#)
- redistribution [2](#)
- referencing Db2 subsystem [198](#)
- referencing tables [198](#)
- refresh interval of Accelerator view [171](#)
- regular accelerators, Accelerator view for [64](#)
- relative byte address, *See* RBA
- remove
 - accelerators [154](#)
 - tables [152](#)
- remove reference tables [205](#), [207](#)
- remove referencing accelerator-only tables [205](#), [207](#)
- removeaccelerator-shadow tables [4](#)
- renewal
 - authentication [1](#)
- REORG in connection with incremental updates [178](#)
- repair [229](#)
- replication engine
 - installing updates [210](#)
 - update packages [211](#)
- replication events [164](#), [183](#)
- restoring
 - partition data [196](#)
 - table data [196](#)
- restrictions
 - accelerator-only tables [49](#)

- RETAIN server [163](#)
- revoke access to remote Db2 subsystem [205](#)
- ROTATE PARTITION, incremental update function [178](#)
- ROUND [46](#)
- row length [44](#)
- running queries [126](#)

S

- Save Trace function, FTP server configuration [163](#)
- save trace information [64](#), [79](#), [158](#), [162](#), [186](#)
- saving storage in z/OS, *See* storage saver
- scalar SQL functions [31](#)
- schema change [124](#)
- schema filters [91](#)
- Select Tables to Add wizard [104](#)
- selecting tables
 - access plan graph [8](#)
 - basic concepts [8](#)
 - overview [2](#)
- SET CURRENT_QUERY_ACCELERATION [259](#)
- sharing credentials [99](#)
- signals table [247](#)
- simulation [7](#)
- simulator for query testing and evaluation [103](#)
- SMP/E [211](#)
- software update transfer [64](#), [79](#)
- software version
 - activation [213](#)
 - switching [64](#), [79](#), [213](#)
- sort order (collating sequence) [41](#)
- space saving [190](#)
- special register [194](#)
- special registers
 - equivalent Netezza functions [35](#)
 - replacing [35](#)
- SQL code [249](#)
- SQL scripts [126](#)
- SQLSTATE [249](#)
- starting incremental updates [177](#)
- states of tables [13](#)
- static SQL queries [7](#), [110](#)
- static SQL queries, bind options [23](#), [259](#)
- status of an accelerator [107](#)
- stopping incremental updates [177](#)
- storage saver
 - archiving partition data [190](#)
 - description [188](#)
 - LRSN conversion from 6-byte to 10-byte, Db2 11 for z/OS [198](#)
 - RBA conversion from 6-byte to 10-byte, Db2 11 for z/OS [198](#)
 - restoring partition data [196](#)
 - restrictions [188](#)
- strings in TIME function [48](#)
- SUBSTR [46](#)
- supergroups [55](#)
- support case [155](#), [158](#), [163](#), [229](#)
- support cases, creating [231](#)
- supported SQL functions [31](#)
- switching between software versions [213](#)
- synchronization of table data [40](#)
- synchronize table schemas [124](#)
- synonyms [55](#)

system
 health [231](#)
 monitoring [231](#)
system table entries [20](#)

T

table skew threshold [171](#)
table specifications
 exporting [153](#)
 importing [154](#)
tables
 defining [104](#)
 disabling query acceleration [119](#)
 enabling for query acceleration [117](#)
 IBM Data Server Manager [85](#)
 loading [112](#)
 possible operations depending on state [13](#)
 removing from accelerator [152](#)
 selecting [8](#)
 states [13](#)
Tables section, Accelerator view [64](#)
task
 cancel [151](#)
task completion order [5](#)
tasks
 overview [91](#)
temporal tables [52](#)
time
 format [47](#)
 representations [41](#)
 values [41](#)
TIME function
 strings [48](#)
TIMESTAMP [47](#)
timestamp precision [52](#)
tracing
 CDC Capture Agent [162](#), [186](#)
 clear information [164](#)
 configuration [155](#)
 delete information [164](#)
 IBM InfoSphere Change Data Capture for z/OS [162](#),
 [186](#)
 incremental updates [162](#), [186](#)
 performance impact [155](#)
 profiles [155](#)
 save information [158](#)
 trace file location [158](#)
transferring update
 Access Server [211](#)
 IBM Db2 Analytics Accelerator for z/OS software
 [211](#)
 Netezza Firmware (FDT) [217](#)
 Netezza Host Platform (HPF) [217](#)
 replication engine [211](#)
TRANSLATE [46](#)
troubleshooting [235](#)
TRUNC [46](#)
truncation [42](#)
truncation of values [41](#)

U

UNICODE [27](#)
Unicode SQL statements [43](#)
unified store [172](#)
update
 accelerator [209](#)
 administration client [222](#)
 authentication [1](#)
 IBM Data Server Manager [222](#)
 IBM Db2 Analytics Accelerator Studio [222](#)
update, credentials [64](#), [79](#)
updating
 Access Server [209](#)
 credentials [99](#)
 IBM Data Server Manager [224](#)
 IBM Db2 Analytics Accelerator software [209](#)
 IBM Db2 Analytics Accelerator Studio from IBM
 Installation Manager [222](#)
 Netezza Firmware (FDT) [216](#)
 Netezza Host Platform (HPF) [216](#)
 Netezza Platform Software (NPS) [209](#)
 replication engine [209](#)
UPPER [46](#)
user IDs [91](#)

V

view encryption status [227](#)
virtual accelerators
 adding [103](#)
 basic concepts [7](#)
 contain EXPLAIN statement [129](#)
 start [75](#)
 stop [75](#)
Visual Explain Graph [7](#)
visual representation [133](#)

W

WAITFORDATA
 description [173](#)
warnings [185](#)
workload balancing [20](#), [110](#)
workspace directory, IBM Db2 Analytics Accelerator Studio
[223](#)

X

XMLAGG function [31](#)

Z

zone maps [2](#), [13](#)
ZPARMs
 QUERY_ACCEL_OPTION [259](#)
 QUERY_ACCELERATION [259](#)



Product Number: 5697-DA5

SH12-7061-10

