

Automatic Binary Optimizer for z/OS
Version 1 Release 3

User's Guide



Note

Before using this information and the product it supports, be sure to read the general information under [“Notices” on page 83](#).

Fourth Edition (September 2019)

This edition applies to Version 1.3 of IBM® Automatic Binary Optimizer for z/OS® (program number 5697-AB1), and IBM Automatic Binary Optimizer for z/OS Trial (program number 5697-TR1), and to all subsequent releases and modifications until otherwise indicated in new editions. Make sure you are using the correct edition for the level of the product.

You can view or download softcopy publications free of charge at www.ibm.com/shop/publications/order/.

© **Copyright International Business Machines Corporation 2015, 2019.**

US Government Users Restricted Rights – Use, duplication or disclosure restricted by GSA ADP Schedule Contract with IBM Corp.

Contents

Tables.....	V
Preface.....	vii
About this book.....	vii
Abbreviated terms.....	vii
How to read syntax diagrams.....	vii
Summary of changes.....	viii
How to send your comments.....	xi
Accessibility features for Automatic Binary Optimizer for z/OS.....	xi
Chapter 1. Overview.....	1
Benefits.....	1
Choosing between using the Enterprise COBOL compiler and using Automatic Binary Optimizer.....	1
Chapter 2. System requirements.....	3
Supported operating systems.....	3
Target hardware levels.....	4
Chapter 3. COBOL module requirements.....	7
Eligible compilers.....	7
COBOL language feature and compiler option support.....	8
Handling ineligible CSECTs.....	9
Chapter 4. Installing and verifying installation.....	11
Installing IBM Automatic Binary Optimizer for z/OS.....	11
Verifying installation using the Installation Verification Program (IVP).....	11
Chapter 5. Optimizing modules	15
Required DD statements.....	15
Optimizer directives.....	16
BOPT.....	16
IEFOPZ.....	18
Optimizer options.....	19
ALLOW.....	20
ARCH.....	20
CSECT.....	21
LIST.....	23
LOG.....	24
REPLACE.....	25
SCAN.....	25
Comments.....	26
Line continuation.....	27
JCL examples.....	28
Specifying optimization with BOPT.....	28
Specifying optimization with IEFOPZ.....	31
Recommended settings for the z/OS JCL REGION and JCL MEMLIMIT parameters.....	32
Specifying the language to be used for ABO messages.....	32
Invoking ABO from TSO, REXX and assembler code.....	33
Optimizing under TSO.....	33

Starting the optimizer from an assembler program.....	37
Chapter 6. Understanding output from the optimization process.....	41
Log files.....	41
Listing transform.....	43
Listing transform contents.....	43
SYSPRINT DD and LIST option.....	49
Chapter 7. Managing optimization and optimized module deployment process.....	51
Optimization and deployment usage scenarios	51
Scenario 1: Optimization process with static deployment.....	52
Scenario 2: Optimization process with dynamic deployment.....	53
Scenario 3: Optimization process using a hybrid approach.....	54
Testing information.....	55
Chapter 8. Resolving problems with optimization and optimized module deployment	57
Resolving problems that occur during optimization time.....	57
Resolving problems encountered during execution.....	57
Changes in COBOL module size after optimization.....	57
Error message and abend code differences.....	58
Application Delivery Foundation for z Systems	58
Run Time Instrumentation Profiler.....	59
Appendix A. JCL sample.....	63
Appendix B. Return codes.....	65
Appendix C. Messages.....	67
Notices.....	83
Trademarks.....	83
List of resources.....	85
IBM Automatic Binary Optimizer for z/OS publications.....	85
Related publications.....	85

Tables

1. Comparing optimizer and compiler use cases.....	2
2. Supported hardware levels.....	4
3. COBOL modules that ABO does not support.....	7
4. Ineligible CSECTs and message issued.....	9
5. Return code and corresponding missing LE PTFs.....	12
6. The ddnames used for binary optimization.....	15
7. optimizer options.....	19
8. Input modules and their containing CSECTs.....	50
9. Output 1: Optimized modules and their CSECTs.....	50
10. Output 2: Listing transforms.....	50
11. Recommended allocation parameters.....	60
12. Recommended allocation parameters.....	63
13. IBM Automatic Binary Optimizer for z/OS return codes.....	65

Preface

About this book

This book is for IBM COBOL compiler customers who use IBM Automatic Binary Optimizer for z/OS to improve the performance of their already compiled COBOL programs.

Abbreviated terms

Certain terms are used in a shortened form in this information. Abbreviations for the terms used most frequently are listed alphabetically in the following table.

Term used	Long form
ABO	IBM Automatic Binary Optimizer for z/OS
CSECT	Control section
EBCDIC	Extended binary coded decimal interchange code
HFS	Hierarchical file system
JCL	Job control language
PDS	Partitioned data set
PDSE	Partitioned data set extended

Other terms, if not commonly understood, are spelled out the first time they appear.

How to read syntax diagrams

Use the following description to read the syntax diagrams in this information:

- Read the syntax diagrams from left to right, from top to bottom, following the path of the line.

The **>>---** symbol indicates the beginning of a syntax diagram.

The **--->** symbol indicates that the syntax diagram is continued on the next line.

The **>---** symbol indicates that the syntax diagram is continued from the previous line.

The **---><** symbol indicates the end of a syntax diagram.

Diagrams of syntactical units other than complete statements start with the **>---** symbol and end with the **--->** symbol.

- Required items appear on the horizontal line (the main path).



- Optional items appear below the main path.

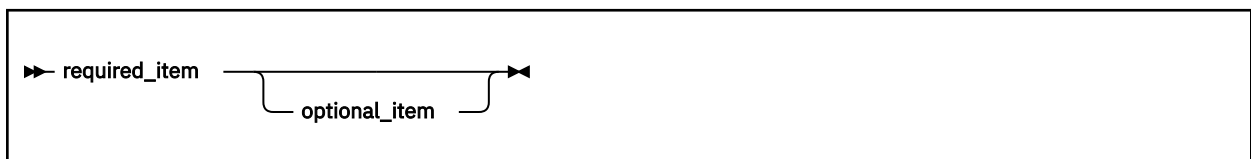

- If you can choose from two or more items, they appear vertically, in a stack. If you must choose one of the items, one item of the stack appears on the main path.



If one of the items is the default, it appears above the main path and the remaining choices are shown below:

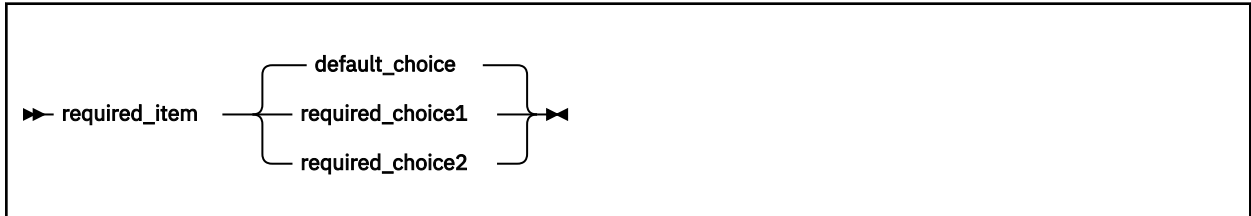

- An arrow returning to the left, above the main line, indicates an item that can be repeated.



- Keywords appear in uppercase (for example, FROM). They must be spelled exactly as shown. Variables appear in all lowercase letters (for example, *column-name*). They represent user-supplied names or values.
- If punctuation marks, parentheses, arithmetic operators, or other such symbols are shown, you must enter them as part of the syntax.

Summary of changes

This section lists the major changes that have been made to this document for IBM Automatic Binary Optimizer for z/OS in Version 1. The latest technical changes are highlighted in the HTML version, or marked by vertical bars (|) in the left margin in the PDF version.

Version 1 Release 3 document refresh in September 2019

- Adds the LINK option requirements when rebinding for the RTI Profiler. (See [“Run Time Instrumentation Profiler”](#) on page 59)
- Adds support for z14 ZR1. (See [“Target hardware levels”](#) on page 4)

Version 1 Release 3 document refresh in January 2019

- Adds support for COBOL modules that are built with the CMPR2 compiler option. (See [“COBOL language feature and compiler option support”](#) on page 8)
- Adds information on alternate ABO invocations. (See [“Invoking ABO from TSO, REXX and assembler code”](#) on page 33)
- Adds information on required record format for OPTLOG and OPTERR, and the data sets specified by the LOG option. (See [“LOG”](#) on page 24 and [Appendix A, “JCL sample,”](#) on page 63)
- Clarifies the IEFOPZ configuration activation steps. (See [“Scenario 2: Optimization process with dynamic deployment”](#) on page 53)

Version 1 Release 3 document refresh in September 2018

- Adds a new optimizer option, LOG, to allow generating additional member-level log files into a particular data set. (See [“LOG”](#) on page 24)

- Adds a binder APAR, OA55985, to the list of PTFs that are required on the systems where ABO is running. (See [“Supported operating systems”](#) on page 3)
- Adds the severity indicator (I, W, E, S, or U) to each ABO message. (See [Appendix C, “Messages,”](#) on page 67)
- Adds messages BOZ4120S and BOZ4121S, and updates messages BOZ1409S, BOZ1446U. (See [Appendix C, “Messages,”](#) on page 67)
- Updates the JCL sample for the first step of using the RTI Profile. (See [“Run Time Instrumentation Profiler”](#) on page 59)

Version 1 Release 3 document refresh in June 2018

- Adds line continuation support for SYSIN files. (See [“Line continuation”](#) on page 27)
- Adds a topic describing the reasons for COBOL module size increase after optimization. (See [“Changes in COBOL module size after optimization”](#) on page 57)
- Adds message BOZ4119, and removes message BOZ1434. (See [Appendix C, “Messages,”](#) on page 67)

Version 1 Release 3 document refresh in February 2018

- The signature bits produced in the ABO listing transform for COBOL CSECTs are now decoded and detailed information about the CSECT are added to the listing transform. (See [“Listing transform contents”](#) on page 43)
- Adds support to allow excluding modules from ABO processing. (See [“BOPT”](#) on page 16 and [“Specifying optimization with BOPT”](#) on page 28)
- Adds a summary table of ineligible COBOL modules. (See [Chapter 3, “COBOL module requirements,”](#) on page 7)
- Adds TEST to the list of supported COBOL compiler options. (See [“COBOL language feature and compiler option support”](#) on page 8)
- Adds items to the ineligible CSECTs table. (See [“Handling ineligible CSECTs”](#) on page 9)
- Adds messages BOZ1437, BOZ1457, BOZ4097, BOZ4116, BOZ4117. (See [Appendix C, “Messages,”](#) on page 67)
- Updates the description of the following messages: BOZ1421, BOZ1428, BOZ1429, BOZ1430, BOZ1431, BOZ4101. (See [Appendix C, “Messages,”](#) on page 67)
- Removes the return code 8. (See [Appendix B, “Return codes,”](#) on page 65)

Version 1 Release 3 with PTF for APAR PI89065 installed

- Adds support for user written SERVICE LABEL statements. (See [“COBOL language feature and compiler option support”](#) on page 8)

Version 1 Release 3 with PTF for APAR PI89064 installed

- Adds support for program segmentation. (See [“COBOL language feature and compiler option support”](#) on page 8)

Version 1 Release 3

- Adds ARCH(12) for generating COBOL code that exploits the new IBM z14 mainframe. (See [“ARCH”](#) on page 20)
- Delivers a new tool, IBM Run Time Instrumentation Profiler, to help identify COBOL modules that are good candidates for optimization using the Automatic Binary Optimizer. (See [“Run Time Instrumentation Profiler”](#) on page 59)

Version 1 Release 2 document refresh in September 2017

- Adds z/OS Version 2.3 to the list of supported operating systems. (See [“Supported operating systems”](#) on page 3)
- Adds CMPR2 to the list of unsupported COBOL features. (See [“COBOL language feature and compiler option support”](#) on page 8)
- Adds notes to COBOL module requirements. (See [Chapter 3, “COBOL module requirements,”](#) on page 7)
- Adds the SYSIN comment directive, which is used to insert comments in the SYSIN flow. (See [“Comments”](#) on page 26)
- Adds message BOZ1003. (See [Appendix C, “Messages,”](#) on page 67)
- Updates the description of the following messages: BOZ1419, BOZ1455. (See [Appendix C, “Messages,”](#) on page 67)

Version 1 Release 2 with PTF for APAR PI77901 installed

- Adds the Installation Verification Program (IVP), BOZJIVP, which enables you to verify that the optimizer is installed correctly and is functional. (See [“Verifying installation using the Installation Verification Program \(IVP\)”](#) on page 11)
- Adds information on the ABO optimization process requiring significantly more time and memory compared to the original compilation process when using Enterprise COBOL V4 and earlier. (See [Chapter 7, “Managing optimization and optimized module deployment process,”](#) on page 51 and [“Recommended settings for the z/OS JCL REGION and JCL MEMLIMIT parameters”](#) on page 32)
- In the listing transform contents, adds an input instructions section that contains the complete list of instructions for the CSECT being optimized. (See [“Listing transform contents”](#) on page 43)

Version 1 Release 2 with PTF for APAR PI73095 installed

- Changes the symbol used to negate a CSECT option expression from a caret (^) to an exclamation point (!). (See [CSECT](#))

Version 1 Release 2

- Adds optimization eligibility for COBOL programs that were compiled with pre-Version 3 IBM COBOL compilers. (See [“Eligible compilers”](#) on page 7)
- Adds support for partially bound modules. (See [“ALLOW”](#) on page 20)
- Allows the optimizer to determine the output member name when using a specific member named on the input. (See [“BOPT”](#) on page 16)
- Adds the following supported COBOL language features. (See [“COBOL language feature and compiler option support”](#) on page 8)
 - CICS® HANDLE ABEND
 - CICS HANDLE AID
- Adds the following new compiler options:
 - [ALLOW](#)
 - [CSECT](#)
 - [HANDLERS](#)
- Adds the following error messages: BOZ1494, BOZ4109, BOZ4110, BOZ4111, BOZ4114. (See [Appendix C, “Messages,”](#) on page 67)
- Removes the following error message: BOZ1425.

How to send your comments

Your feedback is important in helping us to provide accurate, high-quality information. If you have comments about this documentation, contact us in one of these ways:

- Use the Online Readers' Comments Form at <http://www.ibm.com/software/awdtools/rcf>.
- Send your comments to the following address: compinfo@cn.ibm.com.

Be sure to include the name of the document, the publication number, the version of the product, and, if applicable, the specific location (for example, the page number or section heading) of the text that you are commenting on.

When you send information to IBM, you grant IBM a nonexclusive right to use or distribute the information in any way that IBM believes appropriate without incurring any obligation to you.

Accessibility features for Automatic Binary Optimizer for z/OS

Accessibility features assist users who have a disability, such as restricted mobility or limited vision, to use information technology content successfully. The accessibility features in z/OS provide accessibility for Automatic Binary Optimizer for z/OS (ABO).

Accessibility features

z/OS includes the following major accessibility features:

- Interfaces that are commonly used by screen readers and screen-magnifier software
- Keyboard-only navigation
- Ability to customize display attributes such as color, contrast, and font size

z/OS uses the latest W3C Standard, WAI-ARIA 1.0 (<http://www.w3.org/TR/wai-aria/>), to ensure compliance to US Section 508 (<http://www.access-board.gov/guidelines-and-standards/communications-and-it/about-the-section-508-standards/section-508-standards>) and Web Content Accessibility Guidelines (WCAG) 2.0 (<http://www.w3.org/TR/WCAG20/>). To take advantage of accessibility features, use the latest release of your screen reader in combination with the latest web browser that is supported by this product.

The ABO online product documentation in IBM Knowledge Center is enabled for accessibility. The accessibility features of IBM Knowledge Center are described at <http://www.ibm.com/support/knowledgecenter/en/about/releasenotes.html>.

Keyboard navigation

Users can access z/OS user interfaces by using TSO/E or ISPF.

Users can also access z/OS services by using IBM Developer for z Systems® Enterprise Edition.

For information about accessing these interfaces, see the following publications:

- *z/OS TSO/E Primer* (http://www.ibm.com/support/knowledgecenter/SSLTBW_2.2.0/com.ibm.zos.v2r2.ikjp100/toc.htm)
- *z/OS TSO/E User's Guide* (http://www.ibm.com/support/knowledgecenter/SSLTBW_2.2.0/com.ibm.zos.v2r2.ikjc200/toc.htm)
- *z/OS ISPF User's Guide Volume I* (http://www.ibm.com/support/knowledgecenter/SSLTBW_2.2.0/com.ibm.zos.v2r2.f54ug00/toc.htm)
- *IBM Developer for z Systems Knowledge Center* (http://www.ibm.com/support/knowledgecenter/SSQ2R2/rdz_welcome.html?lang=en)

How to send your comments

These guides describe how to use TSO/E and ISPF, including the use of keyboard shortcuts or function keys (PF keys). Each guide includes the default settings for the PF keys and explains how to modify their functions.

Interface information

The ABO online product documentation is available in [IBM Knowledge Center \(https://www.ibm.com/support/knowledgecenter/SSERQD\)](https://www.ibm.com/support/knowledgecenter/SSERQD), which is viewable from a standard web browser.

PDF files have limited accessibility support. With PDF documentation, you can use optional font enlargement, high-contrast display settings, and can navigate by keyboard alone.

To enable your screen reader to accurately read syntax diagrams, source code examples, and text that contains period or comma PICTURE symbols, you must set the screen reader to speak all punctuation.

Assistive technology products work with the user interfaces that are found in z/OS. For specific guidance information, see the documentation for the assistive technology product that you use to access z/OS interfaces.

Related accessibility information

In addition to standard IBM help desk and support websites, IBM has established a TTY telephone service for use by deaf or hard of hearing customers to access sales and support services:

TTY service
800-IBM-3383 (800-426-3383)
(within North America)

IBM and accessibility

For more information about the commitment that IBM has to accessibility, see [IBM Accessibility \(www.ibm.com/able\)](http://www.ibm.com/able).

Chapter 1. Overview

IBM Automatic Binary Optimizer for z/OS (ABO) improves the performance of already compiled IBM COBOL programs. ABO does not require source code, source code migration, or performance options tuning. It uses modern optimization technology to target the latest IBM Z mainframes, including IBM z14, to accelerate the performance of COBOL applications.

The input to ABO is your COBOL program modules. ABO scans the program modules for eligible COBOL programs to optimize. A program is eligible for optimization by ABO if all of the following conditions apply:

- It was generated by an eligible IBM COBOL compiler.
- All the language features are supported.
- The optimization verification passes all succeed.

After validating the input program, ABO processes the program module and produces an optimized program module to target the latest IBM Z mainframes.

z/OS Version 2.1 or later is required to run ABO and the optimized programs. With z/OS Version 2.2 or later, the optimized programs can be run on multiple levels of z/Architecture® without any changes to the application JCL.

Benefits

The optimized programs created by ABO improves performance by exploiting the features in the latest IBM Z mainframes, reduces processing costs, and shortens the programs' execution time.

ABO leverages the latest advancements in COBOL optimization technologies and generates code to target the latest deployment systems that offer the processing power to improve performance.

Earlier COBOL compilers generate code at the ARCH(0) level only. Using the Automatic Binary Optimizer for z/OS upgrades these ARCH(0) level COBOL applications to exploit the latest ARCH(12) z14/z14 ZR1, ARCH(11) z13s/ z13®, and ARCH(10) zEC12/zBC12 mainframes.

Using the Automatic Binary Optimizer on the earlier COBOL programs delivers up to a 25-year jump forward in the evolution of hardware technology, with access to over 600 new hardware instructions that are already on the z14, z13s, z13, zEC12 and zBC12 mainframes.

Choosing between using the Enterprise COBOL compiler and using Automatic Binary Optimizer

IBM Automatic Binary Optimizer for z/OS and the latest IBM Enterprise COBOL compiler serve different but complementary purposes. This section provides you with considerations on when to use ABO and when to enhance performance by recompiling your source code with the latest IBM Enterprise COBOL compilers.

To improve your program's performance, select one of the following ways:

- Use IBM Enterprise COBOL for z/OS V5 or V6 to recompile your program source code
- Use IBM Automatic Binary Optimizer for z/OS to optimize your compiled programs that are not in your recompile plan or if the program source code is not available

Choose which one to use according to [Table 1 on page 2](#).

Table 1. Comparing optimizer and compiler use cases

Use case	IBM Automatic Binary Optimizer for z/OS	IBM Enterprise COBOL compilers
Significant performance improvements without requiring source, migration, or options tuning	√	
Built-in support on z/OS V2.2 and later for targeting multiple hardware levels	√	
Interoperability and legacy compatibility (e.g. PDS input/output, interoperate with OS/VS COBOL and VS COBOL II NORES)	√	
No need to downgrade ARCH setting to match disaster recovery machine	√	
New COBOL application development or to use new COBOL features		√
Maintenance on existing COBOL programs		√
Maximum performance improvements (source, migration, and options tuning required)		√

Chapter 2. System requirements

Supported operating systems

IBM Automatic Binary Optimizer for z/OS can be run on the following operating systems:

- z/OS Version 2.3
- z/OS Version 2.2
- z/OS Version 2.1

ABO requires some PTFs to be applied on the systems where Automatic Binary Optimizer for z/OS is installed and running. Other PTFs are required on systems where the ABO generated optimized modules will be running, even if ABO is not installed on these systems. APAR/PTF (OA47689/UA90982), which is available for z/OS 2.2 only, is required on systems where either ABO or the ABO generated modules are running.

These PTFs are required on systems where ABO is running:

- z/OS V2.3
 - OA55985/UA97356 (Binder)
- z/OS V2.2
 - OA47829/UA78084 (Binder)
 - OA50640/UA82866 (Binder)
 - OA47689/UA90982 (IEFOPZxx SYS1.PARMLIB support)
- z/OS V2.1
 - OA55985/UA97372 (Binder)
- z/OS V2.1
 - OA49419/UA90987 (Binder)
 - OA50460/UA82868 (Binder)
- z/OS V2.1
 - OA55985/UA97377 (Binder)

These PTFs are required on systems where ABO optimized modules are running:

- z/OS V2.3
 - PI84561/UI49013 (Language Environment Automatic Binary Optimizer Runtime Engine)
- z/OS V2.2
 - PI52354/UI33525 (Language Environment Automatic Binary Optimizer Runtime Engine)
 - PI51546/UI33445 (Language Environment Automatic Binary Optimizer Runtime Engine)
 - PI51802/UI32944 (Language Environment CICS system definition sample update)
 - OA47689/UA90982 (IEFOPZxx SYS1.PARMLIB support)
 - PI84563/UI49033 (Language Environment Automatic Binary Optimizer Runtime Engine)
- z/OS V2.1
 - PI55281/UI34924 (Language Environment Automatic Binary Optimizer Runtime Engine)
 - PI54804/UI34935 (Language Environment Automatic Binary Optimizer Runtime Engine)
 - PI55010/UI34414 (Language Environment CICS system definition sample update)
 - PI84564/UI49032 (Language Environment Automatic Binary Optimizer Runtime Engine)

If the same system is going to be used to both run ABO and run the ABO optimized modules then all the PTFs listed above per z/OS version must be installed on this system.

Optional programs that can be used with ABO:

- [Application Delivery Foundation for z Systems V3.1](#)
 - Developer for z Systems Enterprise Edition V14.1
 - Debug for z Systems V14.1
 - Fault Analyzer for z/OS V14.1
 - Application Performance Analyzer for z/OS V14.1

It is highly recommended that the latest IBM Automatic Binary Optimizer or IBM Automatic Binary Optimizer Trial PTFs be installed. See the [fix list page](#).

Target hardware levels

IBM Automatic Binary Optimizer for z/OS can generate program modules for the latest IBM Z servers.

Automatic Binary Optimizer for z/OS uses the same hardware numbering scheme as the COBOL compilers. [Table 2 on page 4](#) lists the hardware levels that are supported by IBM Automatic Binary Optimizer for z/OS Version 1.3. You can use the [ARCH option](#) to specify which hardware level you want the ABO produced modules to target.

Hardware level	Description
10	<p>Generates code that uses instructions available on the 2827-xxxx (IBM zEnterprise® EC12) and 2828-xxxx (IBM zEnterprise BC12) models in z/Architecture mode.</p> <p>Specifically, these level 10 machines and their follow-ons add instructions with support of the following facilities:</p> <ul style="list-style-type: none"> • Execution-hint facility • Load-and-trap facility • Miscellaneous-instructions-extension facility • Transactional-execution facility • Enhanced decimal floating point facility that enables more efficient conversions between zoned decimal data items and decimal floating point data items. Instead of converting zoned decimal data items to packed-decimal data items to perform arithmetic operations, the compiler converts zoned decimal data items directly to decimal floating point data items, and then back again to zoned decimal data items after the computations are complete.
11	<p>Generates code that uses instructions available on the 2964-xxxx (IBM z13®) and 2965-xxx (IBM z13s) models in z/Architecture mode.</p> <p>Specifically, these level 11 machines and their follow-ons add instructions with support of the following facility:</p> <ul style="list-style-type: none"> • Enhanced decimal floating point facility that enables more efficient conversions between packed-decimal data items and decimal floating point intermediate result data items

Table 2. Supported hardware levels (continued)

Hardware level	Description
12	<p>Generates code that uses instructions available on 3906-xxx (IBM z14) and 3907-xxx (IBM z14 ZR1) models in z/Architecture mode.</p> <p>Specifically, these level 12 machines and their follow-ons add instructions that support the vector packed-decimal facility, which accelerates packed-decimal computation by storing intermediate results in vector registers instead of in memory.</p>
<p>Note: ABO can run on any system supported by the z/OS level. For a complete list of IBM Z servers that support z/OS V2.1 and later, see z/OS Server Support.</p>	

Chapter 3. COBOL module requirements

IBM Automatic Binary Optimizer for z/OS optimizes program modules output from the binder and load modules output from the linkage editor. The program modules output from the binder can be either program objects or load modules. Load modules produced by the linkage editor must be acceptable input to the binder for ABO to optimize them.

ABO is able to optimize both fully bound or partially bound program modules. A partially bound module is one that has been bound with CALL=NO or NCAL option and are often contained in a link library. If the ALLOW=NOUNRESEXE option has been specified, ABO will not optimize partially bound program modules. See the [ALLOW option](#) for more details.

ABO does not support the following COBOL modules:

COBOL modules that ABO does not support	Messages issued
Modules that the binder will not process	BOZ4116I followed by BOZ1429U For example, the binder will not process load modules that have ESD names with invalid characters. When ABO encounters a module with an invalid ESD name, ABO will produce a BOZ4116I message and the BOZ4116I message includes the text of binder message IEW2512E. The text of IEW2512E includes the name of the invalid ESD name.
Modules bound with EDIT=NO	BOZ1423S
Signed modules	BOZ1424S
Modules marked not executable	BOZ1422S
Modules that include object files from a prelink step but the prelink step was not done properly	BOZ4116I followed by BOZ1419S For example, prelinking may be improper if it was not performed on all object files. This improper prelink could result in load modules that the binder and ABO will not process. ABO would produce a BOZ4116I message followed by a BOZ1419S message if the binder would not process the module. Prelinking is also not proper if the module includes output from multiple prelink steps. In this case, the original module would normally not run properly and ABO would produce a module that would also not run properly.

ABO scans the CSECTs within the program modules for those that are eligible for optimization. A CSECT is eligible for optimization by ABO if it was generated by an eligible COBOL compiler and all COBOL features used in the original COBOL program are supported by ABO.

Eligible compilers

IBM Automatic Binary Optimizer for z/OS, V1.3, can optimize CSECTs within program modules that were generated by the following COBOL compilers:

- Enterprise COBOL for z/OS V4
- Enterprise COBOL for z/OS V3

- COBOL for OS/390® & VM V2
- COBOL for MVS™ & VM V1.2
- COBOL/370 V1.1
- VS COBOL II V1.4.0 (LE enabled modules only)
- VS COBOL II V1.3.x (LE enabled modules only)

Note: COBOL modules that have been processed by CA-Optimizer cannot be optimized by ABO. For these types of modules it is recommended to use ABO to optimize the original module created by the COBOL compiler before it was processed by CA-Optimizer.

COBOL language feature and compiler option support

Supported COBOL language features and compiler options

The vast majority of COBOL language features are supported using IBM Automatic Binary Optimizer for z/OS.

Here is a list of key COBOL features that are supported in IBM Automatic Binary Optimizer for z/OS Version 1.3.

- ARITH(EXTEND | COMPAT)
- CICS
- CICS HANDLE ABEND
- CICS HANDLE AID
- CICS language translator generated SERVICE LABEL statements
- CMPR2
- DB2®
- DLL
- ENTRY
- IMS
- I/O and debugging declaratives
- NOOPTIMIZE, OPTIMIZE(STD | FULL)
- NUMPROC(NOPFD | PFD | MIG)
- Program segmentation¹
- RECURSIVE
- RENT and NORENT
- SORT and MERGE
- SQL
- SSRANGE
- TEST²
- THREAD

¹ Most cases of Program Segmentation are supported. The remaining unsupported case is when the source for the CSECT processed by ABO contains independent segments, altered GO TO statements and GO TO DEPENDING ON statements. In this case, the message B0Z1455W: unsupported feature "Program Complexity 176" found is issued and the CSECT is skipped.

² Although programs compiled with TEST and any sub-option can be optimized by ABO, LE will not produce a formatted variable dump for the ABO generated module. LE will produce this message instead <prog> was not compiled with the SYM suboption of the TEST. A formatted variable dump cannot be produced.

- TRUNC(STD | BIN | OPT)
- User written SERVICE LABEL statements
- XML

Unsupported COBOL language features and compiler options

IBM Automatic Binary Optimizer for z/OS Version 1.3 does not optimize program modules that use the following COBOL features:

- ACCEPT FROM SYSIPT used in the LABEL declarative
- CLASS
- DISPLAY UPON SYSLST used in the LABEL declarative
- DISPLAY UPON SYSPCH used in the LABEL declarative
- ENTER
- INVOKE
- Java-based object oriented (OO) syntax
- RERUN

Handling ineligible CSECTs

Although IBM Automatic Binary Optimizer for z/OS (ABO) only optimizes CSECTs generated by the compilers listed in the [Eligible compilers](#) section, ABO will tolerate modules containing CSECTs from other COBOL compilers and languages.

ABO examines each CSECT before optimization begins. If any of the conditions in the following table applies, the CSECT is not eligible for optimization, a message is issued and the CSECT is skipped.

Ineligible CSECT	Message issued
The CSECT name does not match the CSECT filter expression specified. See CSECT .	BOZ4113I
The CSECT is generated from a language other than COBOL. For example, it is from HLASM, C/C++, or PL/I.	No specific message issued ³
The CSECT is not compiled by one of the eligible COBOL compilers.	BOZ1455W
The CSECT is compiled by one of the eligible COBOL compilers, but it contains one or more unsupported COBOL statements listed in Summary of unsupported COBOL features .	BOZ1455W
The CSECT is too complex for ABO to safely optimize and generate correct functioning code.	BOZ1455W
The CSECT contains any unexpected data or code. This can include, but is not limited to, any missing, corrupted or other erroneous strings ABO relies on to properly understand the CSECT contents and perform correct optimizations.	BOZ1455W
The CSECT has previously been optimized by ABO.	BOZ1455W

If at least one eligible CSECT for optimization is found in a module then any ineligible CSECTs are copied over unchanged to the target module along with the optimized CSECTs.

³ The optimizer option SCAN=Y can be used to determine the types of CSECTs present in a module.

Chapter 4. Installing and verifying installation

Installing IBM Automatic Binary Optimizer for z/OS

All information about installing IBM Automatic Binary Optimizer for z/OS is included in the Program Directory provided with the product.

It is highly recommended that the latest IBM Automatic Binary Optimizer for z/OS PTFs also be installed. See the [fix list page](#) for a list of IBM Automatic Binary Optimizer for z/OS PTFs and APARs.

Related reference

[“IBM Automatic Binary Optimizer for z/OS publications” on page 85](#)

Verifying installation using the Installation Verification Program (IVP)

After you complete the SMP/E installation of ABO, use the ABO Installation Verification Program (IVP), BOZJIVP, to verify that ABO is installed correctly and is functional.

Overview of BOZJIVP

The ABO Installation Verification Program (IVP), BOZJIVP, is located in the ABO sample library *HLQ.SBOZJCL*, where *HLQ* is the prefix used for the target libraries in your ABO SMP/E installation.

Run the IVP on any system on which you plan to use ABO and on any system where the optimized modules produced by ABO will be running.

Note: ABO can run on any hardware level supported by the minimum z/OS level but the ABO generated optimized modules can only run on zEC12/zBC12, z13/z13s, and z14 systems. See [“Target hardware levels” on page 4](#) for more information. Keep these minimum hardware requirements in mind when you examine the IVP results.

Using BOZJIVP

To proceed with the IVP process on the selected system, edit BOZJIVP according to the included JCL description, and then submit it.

This job contains the following steps:

1. LKED - Link-edit the original COBOL program using as input the object BOZOBJ1 in the same sample library.

Note: The BOZOBJ1 program was compiled using Enterprise COBOL for z/OS V4R2 with the OPT(STD) option in effect. The program source example, BOZSRC1, is also available in the same library for your convenience.

2. GOBEFORE - Run the original program.
3. VERIFY1 - Verify z/OS version eligibility to run ABO.
4. OPTIMIZE - Optimize the original program using ABO.
5. VERIFY2 - Verify IBM z server type eligibility to run ABO optimized modules.
6. GOAFTER - Run optimized version of the original COBOL program.
7. REPORT - Report IVP results.

Results

You will receive a return code of 0 or 4 for each of the preceding steps when the IVP runs successfully. After the REPORT step completes, a report is available in the SYSTRPT output file and in the JESMSGLG JOBLOG.

The following example shows a sample IVP report in the SYSTRPT output file:

```

*** The original program start time is: 10:42:22.72
*** The original program end time is: 10:44:10.71

***
***           Optimization successful!
***
***
*** The optimized program start time is: 10:44:11.41
*** The optimized program end time is: 10:44:15.63

***
*** The elapsed time is reduced by 103.77 sec
***
***
***           Installation verification successful!
***
***

```

The following example shows a sample JESMSGLG JOBLOG. Note that the Installation verification successful! message is present in both the JOBLOG and in the console.

```

10.42.22 JOB07227 HTRT01I
Elapsed
10.42.22 JOB07227 HTRT02I Jobname Stepname ProcStep RC I/O hh:mm:ss.th
hh:mm:ss.th
10.42.22 JOB07227 HTRT03I BOZIVP LKED 00 176 00.01
00.10
10.44.10 JOB07227 HTRT03I BOZIVP GOBEFORE 00 192 01:47.49
01:48.14
10.44.11 JOB07227 HTRT03I BOZIVP OPTIMIZE 00 13457 00.06
00.54
10.44.15 JOB07227 HTRT03I BOZIVP GOAFTER 00 205 04.21
04.37
10.44.15 JOB07227 +*** Installation verification successful!
***
10.44.15 JOB07227 HTRT03I BOZIVP REPORT 00 64 00.01
00.03

```

If the VERIFY1 step fails, you will see the following message in both the JOBLOG and in the console: z/OS version: xx.xx is not a supported z/OS version to run AB0.

If the VERIFY2 step fails, you will see the following message in both the JOBLOG and in the console: IBM z server: (xxxx) is not a supported hardware level to run AB0 optimized modules.

If the OPTIMIZE step fails, verify the messages in this step log file to see which system or Language Environment component is possibly missing. Fix the problem, and then run the BOZJIVP job again.

If the GOAFTER step fails, verify which Language Environment PTF is possibly missing. If one or more of the "Language Environment Automatic Binary Optimizer Runtime Engine" PTFs listed in Supported operating systems are not installed, an OC1 abend is likely to occur. If instead of an abend the GOAFTER step fails with a non-zero return code, the return code corresponds to a missing Language Environment PTF as follows:

Return code	z/OS 2.1	z/OS 2.2	z/OS 2.3
17	PI84564	PI84563	PI84561

Install the required PTFs, and then run the BOZJIVP job again.

An OC1 abend will also occur if you attempt to run the ABO generated modules on a system that is not supported by ABO. See [“Target hardware levels”](#) on page 4 for the supported systems.

Chapter 5. Optimizing modules

To use the Automatic Binary Optimizer for z/OS, write your JCL for the optimization process.

Invoking ABO with the EXEC statement

Use the EXEC job control statement in your JCL to invoke ABO. The EXEC statement is as follows:

```
//OPT EXEC PGM=BOZOPT
```

Required DD statements

The optimization process requires that you specify data sets for specific uses in the optimization process. You can define these data sets in DD statements with the required ddnames. The ddnames that are used by ABO and their characteristics are shown in [Table 6 on page 15](#).

Specifying the optimizer directive BOPT or IEFOPZ

Use BOPT or IEFOPZ to direct ABO. You can include one or more of the BOPT or IEFOPZ directives in the SYSIN DD. For details, see [“BOPT” on page 16](#) and [“IEFOPZ” on page 18](#).

Required DD statements

The table shows the ddnames that are used by the Automatic Binary Optimizer for z/OS.

ddname	Type	Required	Description
STEPLIB	Input	Yes	Specifies the name of the data set containing ABO and the dependent Language Environment® runtime data sets.
SYSIN	Input	Yes	Specifies the location of the file that contains the optimizer directives BOPT and IEFOPZ and optimizer options. As a convenience, you can specify the in-stream file in the JCL using DD *.
OPTLOG	Output	Yes	Specifies that the optimization summary information (such as what is optimized and the location of the optimized binaries) is written to this DD. SCAN output is also written here.
SYSPRINT	Output	No, if the LIST option is specified Yes, if the LIST option is not specified	Specifies the default location for the listing transforms. See also “SYSPRINT DD and LIST option” on page 49 .

ddname	Type	Required	Description
OPTERR	Output	No	Specifies that the optimization diagnostic information is written to this DD in exceptional circumstances.
CEEDUMP	Output	No	Specifies that the optimization dump information is written to this DD in exceptional circumstances.
CEEOPTS	Input	No, if you want English messages. Yes, if you want Japanese messages.	Specifies the language to be used for messages. See also “Specifying the language to be used for ABO messages” on page 32.

Optimizer directives

Use BOPT or IEFOPZ to direct ABO.

BOPT

You can use the BOPT optimizer directive to produce optimized modules based on explicit input and output specifiers.

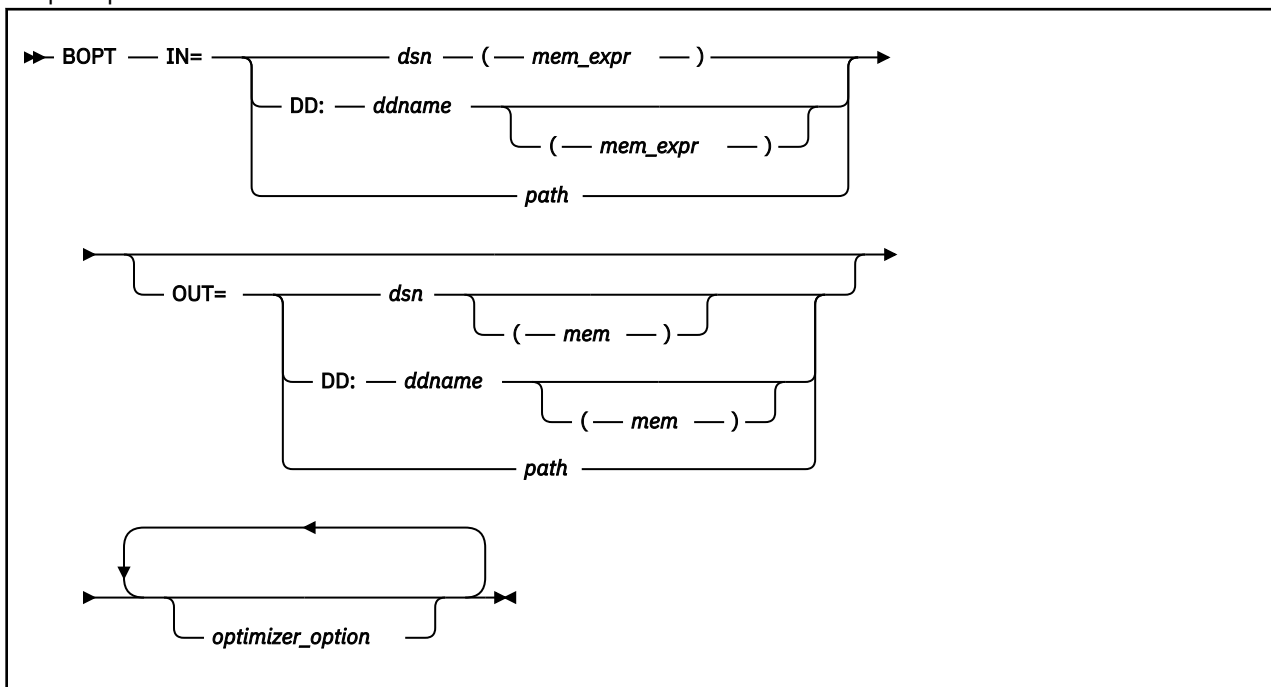

IN

Specifies one input module that you want to optimize or multiple input modules when wildcards are given in the *mem_expr* specifier.

OUT

Specifies one output module, or a PDS(E) for one or more output modules when the *mem* specifier is omitted.

DD:ddname

Specifies a ddname.

dsn

Is a data set name that must include the high-level qualifier.

mem

Is a data set member name.

mem_expr

Is a data set member name that might include an expression. Only the members whose name string match the expression will be processed. Matching is case insensitive.

A regular expression accepts the following symbols:

Matches any string.

?

Matches any character.

|

Can be used as a separator for multiple expressions, with multiple expressions any expression matching the string counts as a match.

!

Negates the entire expression that follows it. For example:

- To skip a single member named MEMA:

```
IN=DD:SYSBIN(!MEMA)
```

- To skip all members whose names begin with MEMB:

```
IN=DD:SYSBIN(!MEMB*)
```

- To skip members named SUB1 and SUB2:

```
IN=DD:SYSBIN(!SUB1|SUB2)
```

path

Is a full HFS path that starts with a slash (/), for example, /home/user1/a.out.opt.

optimizer_option

Is an optimizer option. For a list of optimizer options that you can specify, see [“Optimizer options” on page 19](#).

Notes:

1. The OUT option on BOPT is optional when the SCAN optimizer option is set to Y.
2. When *mem_expr* is specified on the IN option, all members that match *mem_expr* are selected for optimization. Do not include a *mem* specifier on the OUT option when *mem_expr* is specified.
3. When there is no *mem* specifier on the OUT option, the member names for OUT are determined to be those that match the *mem* or *mem_expr* specifier on the IN option.
4. The IN specifier, the OUT specifier, and optimizer options can be in any order.

For examples of the BOPT directive see [“JCL examples” on page 28](#). For sample scenarios of using the BOPT optimizer directive, see [“Scenario 1: Optimization process with static deployment” on page 52](#) and [“Scenario 3: Optimization process using a hybrid approach” on page 54](#).

IEFOPZ

You can use the IEFOPZ optimizer directive to produce optimized modules based on the IEFOPZ configuration.

Note: IEFOPZ is only supported on z/OS V2.2 and later. On z/OS 2.2 the APAR/PTF OA47689/UA90982 must be applied.

For information about IEFOPZ configuration, see step 2 in [“Scenario 2: Optimization process with dynamic deployment”](#) on page 53.

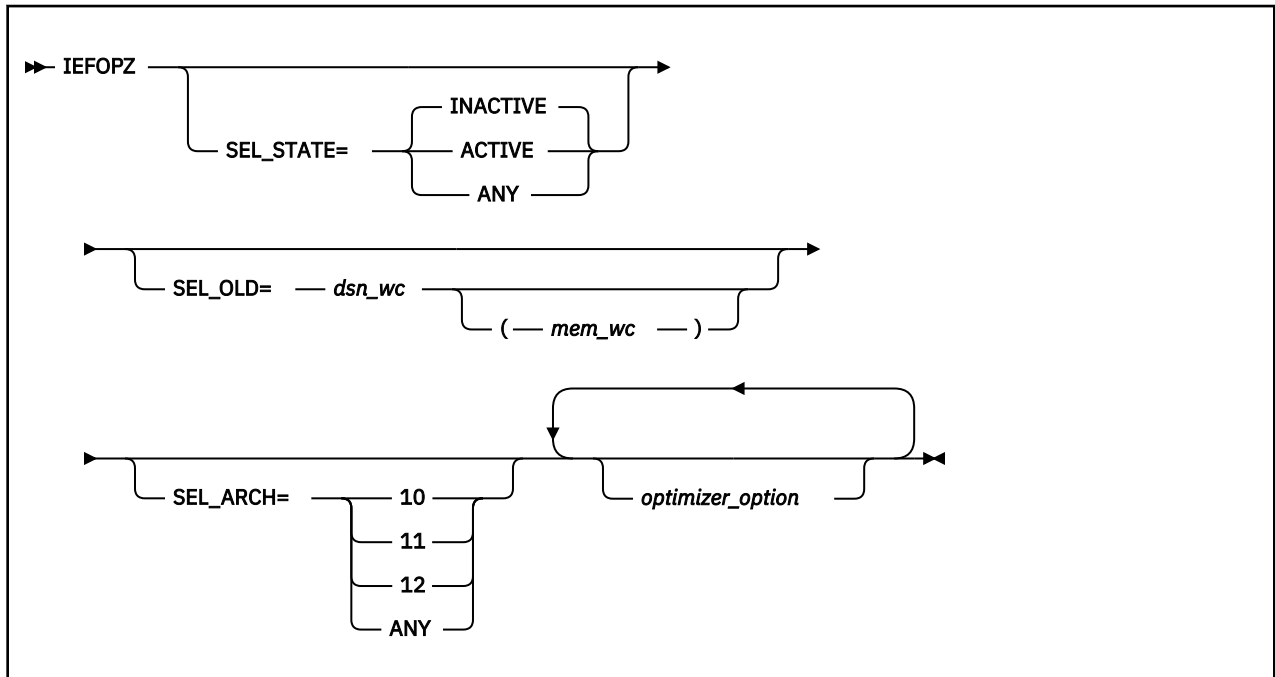

SEL_STATE

Instructs the optimizer to optimize mappings that match the given state.

ANY

Instructs the optimizer to optimize mappings marked as ACTIVE or INACTIVE.

ACTIVE

Instructs the optimizer only to optimize mappings marked as ACTIVE.

INACTIVE

Instructs the optimizer only to optimize mappings marked as INACTIVE.

SEL_OLD

Restricts optimization to mappings with OLD data sets that match the given selector.

dsn_wc

Is a data set name that might include wildcards using the asterisk (*) symbol. For example, *IN*.LOAD.

mem_wc

Is a data set member name that might include wildcards using the asterisk (*) symbol. For example, M*.

SEL_ARCH

Instructs the optimizer to optimize mappings marked with the given architecture.

10

Instructs the optimizer only to optimize mappings marked as ARCH(10).

11

Instructs the optimizer only to optimize mappings marked as ARCH(11).

12

Instructs the optimizer only to optimize mappings marked as ARCH(12).

ANY

Instructs the optimizer to optimize mappings marked as ARCH(10), ARCH(11), or ARCH(12).

optimizer_option

Is an optimizer option. For a list of optimizer options that you can specify, see [“Optimizer options” on page 19](#).

Notes:

1. Mapping refers to the association of OLD to NEW modules in the IEFOPZ configuration.
2. By default, all INACTIVE modules in OLD data sets of an IEFOPZ configuration are optimized at architecture levels as determined by NEW data sets and as determined by the IncludeMembers and ExcludeMembers configuration specifiers. The SEL_OLD= and SEL_ARCH= are selectors that can be used to restrict optimization or scanning to a subset of these modules.

The SEL_STATE= is a selector that can be used to change optimization or scanning to ACTIVE modules or to modules of ANY state. While scanning of ACTIVE modules poses no risk, optimization of ACTIVE modules could cause problems for programs that use the ACTIVE modules. Care should be used with selectors SEL_STATE=ACTIVE or SEL_STATE=ANY and when optimization (as opposed to scanning) is performed.

3. The IN specifier, the OUT specifier, and optimizer options can be in any order.

For examples of the IEFOPZ directive see [“JCL examples” on page 28](#). For a sample scenario of using the IEFOPZ optimizer directive, see [“Scenario 2: Optimization process with dynamic deployment” on page 53](#).

Optimizer options

An optimizer option is an Automatic Binary Optimizer for z/OS option that is applicable to both the BOPT and IEFOPZ optimizer directives.

Optimizer options can be placed at the start of the SYSIN file on one or more lines, or on the BOPT or IEFOPZ optimizer directives.

A global option is an optimizer option that is specified on a line that does not include a BOPT or IEFOPZ optimizer directive. The value of a global option is referred to as the global setting for the option.

When an optimizer option is specified on a particular line that has an optimizer directive, the value applies to that optimization optimizer directive only and reverts back to the global setting for subsequent statements.

[Table 7 on page 19](#) summarizes the optimizer options that apply to both BOPT and IEFOPZ.

Option	Default	Description
“ALLOW” on page 20	ALLOW=UNRESEXE	Controls the type of program modules that ABO will accept.
“ARCH” on page 20	ARCH=10	Specifies the target hardware level.
“CSECT” on page 21	If you do not specify the CSECT option, ABO will process all eligible CSECTs.	Allows the user to limit processing to one or more CSECTs.
HANDLERS	HANDLERS=Y	Specifies if user written or CICS ABEND handlers may be present and active anywhere in the application.

Table 7. optimizer options (continued)

Option	Default	Description
“LIST” on page 23	If you do not specify the LIST option, the listing transforms are placed in the location according to SYSPRINT DD.	Specifies the location of the generated listing transforms.
“LOG” on page 24	If you do not specify the LOG option, ABO will not generate member-level log files.	Specifies the location of the member-level log files to be additionally generated.
“REPLACE” on page 25	REPLACE=Y	Controls whether the output module is written or not.
“SCAN” on page 25	SCAN=N	Controls whether to optimize or scan the program modules.
<p>Note: The ARCH option can be specified at a global level and on the BOPT directive. It cannot be specified on the IEFOPZ directive. For IEFOPZ, use the SEL_ARCH option to select parts of an IEFOPZ configuration matching the SEL_ARCH value to optimize.</p>		

ALLOW

Purpose

The ALLOW option controls the type of program modules that the Automatic Binary Optimizer for z/OS will accept.

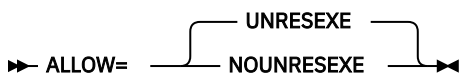

Default

ALLOW=UNRESEXE

Usage

When ALLOW=UNRESEXE is specified, ABO accepts fully bound modules or partially bound modules. The only type of partially bound program modules accepted by the optimizer are those linked with the CALL=NO or NCAL binder option. If the input module is fully bound then the optimized output module will be fully bound. If the input module is partially bound then the optimized module will be partially bound.

When ALLOW=NOUNRESEXE is specified, ABO only accepts fully bound program modules (program object or load module) and always produces a fully bound program module. If partially bound modules are processed when ALLOW=NOUNRESEXE is specified then message BOZ1494S is issued.

ARCH

Purpose

The ARCH option specifies the target hardware level.

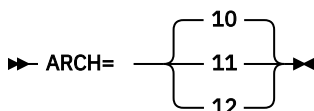

Default

ARCH=10

Usage

Use the ARCH option to specify the hardware level that the optimized modules produced by ABO will target.

Optimized modules produced using a lower ARCH setting will run on a higher ARCH system. However optimized modules from a higher ARCH setting will not work on a lower ARCH system.

ARCH setting	Can only be run on IBM Z mainframe level
ARCH=10	zEC12/zBC12, z13/z13s, z14, z14 ZR1
ARCH=11	z13/z13s, z14, z14 ZR1
ARCH=12	z14, z14 ZR1

If an invalid combination is attempted then the program is likely to terminate with the following runtime LE message:

```
CEE3201S The system detected an operation exception (System Completion Code=0C1)
```

For details of these ARCH levels, see [“Target hardware levels” on page 4](#).

CSECT

Purpose

The CSECT option allows you to limit processing to zero or more CSECTs.

```
➤ CSECT= — expr ➤
```

Default

By default, if you do not specify the CSECT option, ABO processes all eligible CSECTs.

Parameter

expr

A regular expression for the CSECTs that you want to process. Only the CSECTs whose name string match the expression will be processed. Matching is case insensitive.

Usage

A regular expression accepts the following symbols:

*

Matches any string.

?

Matches any character.

|

Can be used as a separator for multiple expressions, with multiple expressions any expression matching the string counts as a match.

!

Negates the entire expression that follows it. For example:

- To skip a single CSECT named PROGA:

```
CSECT=!PROGA
```

- To skip all CSECTs whose names begin with PROGB:

```
CSECT=!PROGB*
```

- To skip CSECTs named SUB1 and SUB2:

```
CSECT=!SUB1|SUB2
```

Notes:

- Spaces and brackets are not allowed in a regular expression.
- An expression must match the entire string. A partial match does not count as a match. This means the expression M*2 matches the string MA2 but not the string MA2A.
- Due to different character encodings across EBCDIC code pages for the special characters usable in regular expressions, this option should only be used in the following code pages:
 - IBM-1047
 - IBM-37/1140
 - IBM-285/1146
 - IBM-924

Example 1

In the following example, the CSECTs that do not match the wildcard filter are not processed.

JCL COMMAND

```
BOPT IN=DD:SYSBIN(*) OUT=DD:SYSBOUT CSECT=SUB*1*
```

OUTPUT (in OPTLOG)

```
...
10:46:04 Processing CSECT filter expression 'SUB*1*' on member CALLLITT
10:46:04 CSECT CALLLIT was excluded by filter - skip
10:46:04 Processing CSECT SUB01L00, in member CALLLITT
10:46:04 Optimizing CSECT SUB01L00 for zEC12
10:46:04 Succeeded in optimizing SUB01L00
10:46:04 Generating listing transform into DD:SYSPRINT
10:46:04 CSECT SUB02L00 was excluded by filter - skip
10:46:04 CSECT SUB03L00 was excluded by filter - skip
10:46:04 CSECT SUB04L00 was excluded by filter - skip
10:46:04 CSECT SUB05L00 was excluded by filter - skip
10:46:04 CSECT SUB06L00 was excluded by filter - skip
10:46:04 CSECT SUB07L00 was excluded by filter - skip
10:46:04 CSECT SUB08L00 was excluded by filter - skip
10:46:04 CSECT SUB09L00 was excluded by filter - skip
10:46:04 Processing CSECT SUB10L00, in member CALLLITT
10:46:04 Optimizing CSECT SUB10L00 for zEC12
10:46:04 Succeeded in optimizing SUB10L00
10:46:04 Generating listing transform into DD:SYSPRINT
10:46:04 Finished processing, processed 2 of 11 CSECTs in member CALLLITT
```

Example 2

The following example shows how to specify multiple expressions for matching.

JCL COMMAND

```
BOPT IN=DD:SYSBIN(*) OUT=DD:SYSBOUT CSECT=SUB01L00|SUB02L00
```

OUTPUT

```
...
10:49:13 Processing CSECT filter expression 'SUB01L00|SUB02L00' on member CALLLITT
10:49:13 CSECT CALLLIT was excluded by filter - skip
10:49:13 Processing CSECT SUB01L00, in member CALLLITT
10:49:13 Optimizing CSECT SUB01L00 for zEC12
10:49:13 Succeeded in optimizing SUB01L00
10:49:13 Generating listing transform into DD:SYSPRINT
10:49:13 Processing CSECT SUB02L00, in member CALLLITT
10:49:13 Optimizing CSECT SUB02L00 for zEC12
10:49:13 Succeeded in optimizing SUB02L00
10:49:13 Generating listing transform into DD:SYSPRINT
10:49:13 CSECT SUB03L00 was excluded by filter - skip
10:49:13 CSECT SUB04L00 was excluded by filter - skip
```

```

10:49:13 CSECT SUB05L00 was excluded by filter - skip
10:49:13 CSECT SUB06L00 was excluded by filter - skip
10:49:13 CSECT SUB07L00 was excluded by filter - skip
10:49:13 CSECT SUB08L00 was excluded by filter - skip
10:49:13 CSECT SUB09L00 was excluded by filter - skip
10:49:13 CSECT SUB10L00 was excluded by filter - skip
10:49:13 Finished processing, processed 2 of 11 CSECTs in member CALLLITT

```

Example 3

In the following example, MEM1 in dataset HLQ.IN.LOAD has two CSECTs named A1 and B1. To limit ABO processing to only A1, use a CSECT=A* filter as follows:

JCL COMMAND

```
BOPT IN=HLQ.IN.LOAD(MEM1) OUT=HLQ.OUT.LOAD(MEM1) CSECT=A*
```

With this CSECT=A* filter in place the OPTLOG looks like the following:

OUTPUT

```

...
17:46:04 Processing CSECT filter expression 'A*' on member MEM1
17:46:04 Processing CSECT A1, in member MEM1
17:46:04     Optimizing CSECT A1 for zEC12
17:46:04     Succeeded in optimizing A1
17:46:04     Generating listing transform into DD:SYSPRINT
17:46:04 CSECT B1 was excluded by filter - skip
17:46:04 Finished processing, processed 1 of 2 CSECTs in member MEM1
...

```

Alternatively CSECT=A* can be specified as a global option so it applies to all subsequent BOPT and IEFOPZ directives unless overridden by a particular directive:

```

//SYSIN DD *
      CSECT=A*
      BOPT IN=HLQ.IN.LOAD(MEM1) OUT=HLQ.OUT.LOAD(MEM1A)
      BOPT IN=HLQ.IN.LOAD(MEM1) OUT=HLQ.OUT.LOAD(MEM1B) CSECT=B*

```

After processing, the member MEM1A will contain the optimized CSECT A1 and the original CSECT B1, and member MEM1B will contain the optimized CSECT B1 and the original CSECT A1.

LIST

Purpose

The LIST option specifies the location of the generated listing transforms.

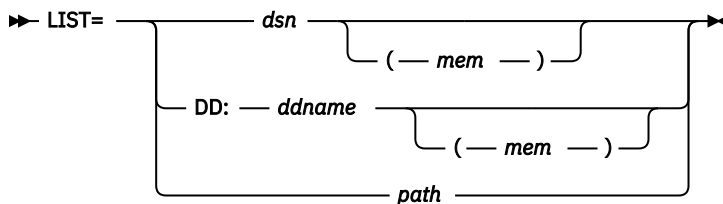

Default

By default, if you do not specify the LIST option, the listing transforms are placed in the location according to SYSPRINT DD.

Parameters

dsn

Is a data set name that must include the high-level qualifier.

mem

Is a data set member name.

DD:ddname

Specifies a ddname.

path

Is a full HFS path that starts with a slash (/), for example, /home/user1/a.list.

Usage

The target of the LIST option can be one of the following items:

- A sequential data set or member of a PDSE (not PDS). The output of multiple CSECT optimizations are added to this single sequential data set.
- A PDS or PDSE. When a CSECT is optimized, the listing transform particular to that CSECT is placed in a member of the PDS or PDSE where the member name is based on the CSECT name (upper cased and truncated to 8 characters). The contents of the member, if any, are overwritten even if the former contents are produced by the optimizer in previous invocations.
- An HFS path. The output of multiple CSECT optimizations are added to this HFS file.

Related information

SYSPRINT DD.

LOG**Purpose**

The LOG option specifies the location of the member-level log files to be additionally generated.

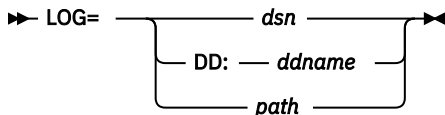
**Default**

By default, if you do not specify the LOG option, ABO will not generate member-level log files. Note that regardless of the LOG option the output from the entire ABO invocation will always be generated in the location according to OPTLOG DD.

Parameters**dsn**

Is a data set name that must include the high-level qualifier.

DD:ddname

Specifies a ddname.

path

Is a full HFS path that starts with a slash(/).

Usage

The target of the LOG option can be one of the following items:

- A PDS or PDSE. When a member is optimized, the log output particular to that member is placed in a member of the PDS or PDSE where the member name is based on the optimized member name (upper-cased and truncated to 8 characters). The contents of the member, if any, are overwritten even if the former contents were produced by ABO in previous invocations.
- An HFS path pointing to a directory. When a member is optimized, the log output particular to that member is placed in a file in the specified HFS directory where the file name is based on the optimized member name appended with .log. The contents of the member, if any, are overwritten even if the former contents were produced by ABO in previous invocations.

Notes:

1. The target of the LOG option must be either a PDS or PDSE with no member specified, or an HFS path that points to a directory. If the target of the LOG option is specified as a PDS or PDSE with a member specified, a sequential data set, or an HFS file, an error message will be issued.
2. The target data set of the LOG option should follow the recommended allocation parameters of the OPTLOG in [Table 12](#) on page 63.

Example 1

```
BOPT IN=DD:SYSBIN(*) OUT=DD:SYSBOUT LOG=HLQ.LOG.OUT
```

Example 2

```
BOPT IN=DD:SYSBIN(*) OUT=DD:SYSBOUT LOG=DD:LOG
```

Example 3

```
BOPT IN=DD:SYSBIN(*) OUT=DD:SYSBOUT LOG=/home/user1/logdir
```

For more information, see [“Log files”](#) on page 41.

REPLACE

Purpose

Controls whether the output module is written or not.

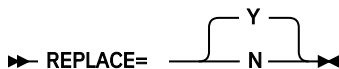

Default

```
REPLACE=Y
```

Usage

When REPLACE=Y and SCAN=N, the optimized module is written to the output module regardless of whether the output module exists.

- If the output module does not exist, the output module will be created and written.
- If the output module already exists, its content will be overwritten.

However, if there are no eligible COBOL CSECTs present that can be optimized, nothing is written to the output module.

When REPLACE=N is specified, optimization or scanning of the input module is bypassed if the output module already exists; nothing is written to the output module.

You can use REPLACE=N to bypass optimization for already optimized modules. For example, if after binary optimization, you add new members to the original data sets and you want to optimize only the new members, you can use a member wildcard with REPLACE=N as follows:

```
BOPT IN=HLQ.IN.LOAD(*) OUT=HLQ.OUT.LOAD REPLACE=N
```

In some cases, the optimizer prematurely terminates because of exceeded time or other abnormal conditions. To solve the problem, you can incrementally build the optimized modules in a sequence of jobs without spending time repeating optimizations done in an earlier job. Or you can use REPLACE=N in these cases.

SCAN

Purpose

The SCAN option instructs ABO whether to optimize or to scan the program modules

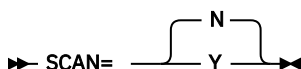

Default

SCAN=N

Usage

When SCAN=N is in effect, ABO performs optimization on the input program modules.

When SCAN=Y is in effect, ABO scans the input program modules instead of performing optimization. No output modules are produced.

The REPLACE=N option can affect whether scanning is performed:

- If REPLACE=N is specified on the BOPT directive and the output module on the OUT option already exists, scanning of the module on the IN option is bypassed.
- If REPLACE=N is specified on the IEFOPZ directive, scanning of the member of the OLD data set is bypassed if the member of the NEW data set already exists.

If you exclude the OUT option on the BOPT directive, scanning is always performed regardless of the value of the REPLACE option.

In the scanning mode, the optimizer checks the input and output program modules, and lists the CSECTS in the modules. Scanning output is written to the OPTLOG DD.

You can use SCAN=Y to test the SYSIN setup or to see what modules are present and their contents. If the program is ineligible for optimization due to the original compiler used, this is also indicated in the scanning output.

For more information, see [“The log file for scanning”](#) on page 42.

Comments

A comment is specified by starting with the (#) character.

When using the (#) character, the following rules apply:

- If the first non-blank character on a line of the SYSIN file is the (#) character, the rest of the line is ignored.
- If ABO sees a (#) character, which is preceded by a blank, on an input line of SYSIN file, the rest of the line is ignored.

Example 1

```
#BOPT IN=DD:SYSBIN OUT=SYSBOUT  
#BOPT IN=SYSBIN OUT=SYSBOUT
```

In example 1, both of the BOPT directives are commented out. On the first line, the # character is in column 1 and the rest of the line is ignored. On the second line, the first non-blank character is the # character and the rest of the line is ignored.

Example 2

```
# Optimizing all members of library  
# Note: we don't compile a member optimized earlier and found in the OUT dataset  
BOPT IN=SYSBIN(*) OUT=SYSBOUT REPLACE=N
```

Example 2 shows adding two full lines of informational comments to the SYSIN file.

Example 3

```
BOPT IN=SYSBIN(*) OUT=SYSBOUT #
```

In example 3, the # character at the end of a line is ignored.

Example 4

```
BOPT IN=SYSBIN(*) OUT=SYSBOUT #optimizing library files
```

Example 4 shows adding a comment after a directive.

Line continuation

Line continuation in a SYSIN file is specified by the (+) or (-) continuation character, which indicates the next line should be read as if it were a part of the previous line. Line continuation is not required but can be used to break up long lines to simplify editing or to ease consumption by other tooling that may have line length restrictions.

The (+) or (-) continuation character must be the last non-blank and non-comment character on a line. When using the continuation characters, the following rules apply:

- The (-) character can only be used to continue a line following complete options, directives, or specifiers. Line continuation begins at column 1 on the next line. The (-) character must be preceded by one or more blanks.
- The (+) character can be used to continue a line following complete options, directives, or specifiers, or in the middle of options, directives, or specifiers. Line continuation begins with the first non-blank character on the next line. When continuing complete options, directives, or specifiers, the (+) character must be preceded by one or more blanks.
- Blanks that precede the line continuation character will be included in the concatenated line.
- The comment character (#) takes precedence over the line continuation character. If a line continuation character is part of a comment, it will be ignored as part of that comment and not continue the comment.

An error message might be issued if the continuation character is in an unexpected position.

These examples show the JCL using the BOPT optimizer directive. The examples are not full examples. They are intended to reflect what the user should specify in the SYSIN file. For basic JCL configuration, see [Appendix A, “JCL sample,”](#) on page 63.

Example 1

```
//SYSIN DD *
HANDLERS=Y -
ARCH=11 -
ALLOW=UNRESEXE
BOPT IN=HLQ.LOAD.APPXYZ1.ORIG(*) -
OUT=HLQ.LOAD.APPXYZ1.ABO
```

This example is interpreted by ABO as the following:

```
//SYSIN DD *
HANDLERS=Y ARCH=11 ALLOW=UNRESEXE
BOPT IN=HLQ.LOAD.APPXYZ1.ORIG(*) OUT=HLQ.LOAD.APPXYZ1.ABO
```

Note that blanks preceding the continuation character are included in the concatenated string in all cases.

Example 2

```
//SYSIN DD *
                                ARCH=12  +
H+
A+
N+
D+
L+
E+
R+
S+
  =+
    Y +
                                ALLOW=UNRESEXE

BOPT IN=HLQ.LOAD.APPXYZ1.OR+
IG(*) -
OUT=HLQ.LOAD.APPXYZ1.ABO
```

This example shows how the (+) character allows continuing wherever desired on the next line (at the first non-blank) instead of only at column 1, and how the (+) character can be used to continue an option, directive, or specifier that is not complete. This example is interpreted by ABO as the following:

```
//SYSIN DD *
ARCH=12 HANDLERS=Y ALLOW=UNRESEXE
BOPT IN=HLQ.LOAD.APPXYZ1.ORIG(*) OUT=HLQ.LOAD.APPXYZ1.ABO
```

Example 3

```
//SYSOPTF DD *
# some comment + (1)
          ARCH=12 + #other comment - (2)
          HANDLERS=Y + (3)
          ALLOW=UNRESEXE (4)
BOPT IN=HLQ.LOAD.APPXYZ1.ORIG(*) OUT=HLQ.LOAD.APPXYZ1.ABO (5)
```

This example is processed by ABO as the following:

```
//SYSOPTF DD *
ARCH=12 HANDLERS=Y ALLOW=UNRESEXE
BOPT IN=HLQ.LOAD.APPXYZ1.ORIG(*) OUT=HLQ.LOAD.APPXYZ1.ABO
```

The (+) character on line 1 and the (-) character on line 2 are ignored because they are part of comments. The (+) characters on line 2, 3 are treated as line continuation characters because they are the last non-comment and non-blank characters on the lines.

JCL examples

You can use the job control language (JCL) statements that are shown in these examples to process compiled COBOL modules with the Automatic Binary Optimizer for z/OS.

Specifying optimization with BOPT

These examples show the JCL using the BOPT optimizer directive.

The examples in this section are not full examples. They are intended to reflect what the user should specify in the SYSIN file. For basic JCL configuration, see [Appendix A, “JCL sample,” on page 63](#).

Example 1. Specifying I/O modules using data set names

In this example, input and output modules are determined by the BOPT line. Input and output data set names are given precisely rather than specified in ddnames.

```
...
//SYSIN DD *
ARCH=12
BOPT IN=HLQ.IN.LOAD(MEM1) OUT=HLQ.OUT.LOAD(MEM1)
```

Example 2. Specifying I/O modules using ddnames

In this example, input and output modules are specified using ddnames.

```
...
//SYSBIN DD DSN=HLQ.IN.LOAD,DISP=SHR
//SYSBOUT DD DSN=HLQ.OUT.LOAD,DISP=SHR
//SYSIN DD *
ARCH=12
BOPT IN=DD:SYSBIN(MEM1) OUT=DD:SYSBOUT(MEM1)
```

Example 3. Specifying I/O modules using HFS paths

In this example, the input and output modules are specified using HFS paths. You must use fully qualified HFS paths that start with a slash (/).

```

...
//SYSIN DD *
ARCH=12
BOPT IN=/home/user1/a.out OUT=/home/user1/a.out.opt

```

Example 4. Specifying an input module and omitting the output member specifier

In this example, an input module is specified and the output member specifier is omitted. The member name in the output PDS(E) for the optimized module will be the same name as the specified member of the input PDS(E).

```

...
//SYSBIN DD DSN=HLQ.IN.LOAD,DISP=SHR
//SYSBOUT DD DSN=HLQ.OUT.LOAD,DISP=SHR
//SYSIN DD *
ARCH=10
BOPT IN=DD:SYSBIN(MEM1) OUT=DD:SYSBOUT

```

Example 5. Specifying multiple input modules using an expression

In this example, multiple input modules are specified using an expression. The member name in the output PDS(E) for an optimized module will be the same name as the corresponding member of the input PDS(E).

To include modules with names that start with MEM:

```

...
//SYSBIN DD DSN=HLQ.IN.LOAD,DISP=SHR
//SYSBOUT DD DSN=HLQ.OUT.LOAD,DISP=SHR
//SYSIN DD *
ARCH=10
BOPT IN=DD:SYSBIN(MEM*) OUT=DD:SYSBOUT

```

To exclude a single module named MEMA:

```

...
//SYSBIN DD DSN=HLQ.IN.LOAD,DISP=SHR
//SYSBOUT DD DSN=HLQ.OUT.LOAD,DISP=SHR
//SYSIN DD *
ARCH=10
BOPT IN=DD:SYSBIN(!MEMA) OUT=DD:SYSBOUT

```

To exclude all members whose names begin with MEMB:

```

...
//SYSBIN DD DSN=HLQ.IN.LOAD,DISP=SHR
//SYSBOUT DD DSN=HLQ.OUT.LOAD,DISP=SHR
//SYSIN DD *
ARCH=10
BOPT IN=DD:SYSBIN(!MEMB*) OUT=DD:SYSBOUT

```

To exclude members named SUB1 and SUB2:

```

...
//SYSBIN DD DSN=HLQ.IN.LOAD,DISP=SHR
//SYSBOUT DD DSN=HLQ.OUT.LOAD,DISP=SHR
//SYSIN DD *
ARCH=10
BOPT IN=DD:SYSBIN(!SUB1|SUB2) OUT=DD:SYSBOUT

```

Example 6. Specifying multiple input modules by using multiple BOPT optimizer directives

In this example, multiple input modules are specified using multiple BOPT optimizer directives:

```

...
//SYSIN DD *
ARCH=10

```

```
BOPT IN=HLQ.IN.LOAD(MEM1) OUT=HLQ.OUT.LOAD(MEM1)
BOPT IN=HLQ.IN.LOAD(MEM5) OUT=HLQ.OUT.LOAD(MEM5)
```

Example 7. Bypassing optimizations or scans with the REPLACE option

In this example, the REPLACE option is used. REPLACE=N bypasses optimization or scanning if the associated output modules already exist. In this example, the optimizer performs optimization in the first and third BOPT directives. The optimizer bypasses optimization in the second BOPT directive and scanning in the last BOPT directive REPLACE=N is specified, and the output modules were created in the first and third BOPT directives.

```
/*
//SYSIN DD *
ARCH=10
BOPT IN=HLQ.IN.LOAD(MEM1) OUT=HLQ.OUT.LOAD(MEM1) REPLACE=Y
BOPT IN=HLQ.IN.LOAD(MEM1) OUT=HLQ.OUT.LOAD(MEM1) REPLACE=N
BOPT IN=HLQ.IN.LOAD(*) OUT=HLQ.OUT.LOAD REPLACE=Y
BOPT IN=HLQ.IN.LOAD(*) OUT=HLQ.OUT.LOAD SCAN=Y REPLACE=N
```

Example 8. Specifying global and local optimizer options

In the example, global and local options are used. ARCH=11, REPLACE=N and HANDLERS=N apply to the first BOPT directive; ARCH=10, REPLACE=Y and the default setting of HANDLERS=Y apply to the second BOPT directive.

```
/*
//SYSBOUT DD DSN=HLQ.OUT.LOAD,DISP=SHR
//SYSIN DD *
ARCH=10 REPLACE=N
BOPT IN=HLQ.IN.LOAD(MEM1) OUT=DD:SYSBOUT(MEM1) ARCH=11 HANDLERS=N
BOPT IN=HLQ.IN.LOAD(MEM1) OUT=DD:SYSBOUT(MEM1) REPLACE=Y
```

Example 9. Switching to scan mode by using global SCAN

The following example changes the mode from optimizing input modules to scanning input modules using the global option SCAN. In this scan mode, output modules are not written. The OUT option is processed, for example for correct syntax, but otherwise ignored. For details about the SCAN option, see [“SCAN” on page 25](#).

The optimizer reverts back to the optimization mode for the second BOPT directive.

```
/*
//SYSBOUT DD DSN=HLQ.OUT.LOAD,DISP=SHR
//SYSIN DD *
ARCH=11 SCAN=Y
BOPT IN=HLQ.IN.LOAD(MEM1) OUT=DD:SYSBOUT(MEM1)
BOPT IN=HLQ.IN.LOAD(MEM1) OUT=DD:SYSBOUT(MEM1) SCAN=N
```

Example 10. Specifying ALLOW options

This example shows a global setting of ALLOW=NOUNRESEXE being specified with a local override for the second BOPT directive.

The first (MEM1) and third (MEM3) BOPT directives are done using ALLOW=NOUNRESEXE meaning that only fully bound program modules will be accepted. If a partially bound program module is encountered then the BOZ1494S message will be issued.

The second (MEM2) BOPT directive is done using ALLOW=UNRESEXE so both fully and partially bound program modules are accepted as input.

```
/*
//SYSBOUT DD DSN=HLQ.OUT.LOAD,DISP=SHR
//SYSIN DD *
ARCH=11 ALLOW=NOUNRESEXE
BOPT IN=HLQ.IN.LOAD(MEM1) OUT=DD:SYSBOUT(MEM1)
```

```
BOPT IN=HLQ.IN.LOAD(MEM2) OUT=DD:SYSBOUT(MEM2) ALLOW=UNRESEXE
BOPT IN=HLQ.IN.LOAD(MEM3) OUT=DD:SYSBOUT(MEM3)
```

Specifying optimization with IEFOPZ

These examples show the JCL using the IEFOPZ optimizer directive.

The examples in this section are not full examples. They are intended to reflect what the user should specify in the SYSIN file. For basic JCL configuration, see [Appendix A, “JCL sample,”](#) on page 63.

Example 1. Single ARCH configuration

This example shows the minimal JCL for running ABO with the IEFOPZ directive.

You can use this JCL when your IEFOPZ configuration includes only one ARCH level.

```
...
//SYSIN DD *
IEFOPZ
```

Example 2. Multiple ARCH configuration

If your IEFOPZ configuration includes more than one ARCH level, specify separate IEFOPZ directives lines to avoid listing file name collisions.

```
...
//SYSIN DD *
IEFOPZ SEL_ARCH=11 LIST=HLQ.OUT1.ARCH11.LIST
IEFOPZ SEL_ARCH=12 LIST=HLQ.OUT1.ARCH12.LIST
```

Example 3. Restricting optimization using the SEL_STATE and SEL_ARCH selectors

The following example produces optimized modules for those OLDNEW mappings that are marked as INACTIVE. As with example 2, if mappings have more than one ARCH level, the LIST option is used to avoid listing file name collisions.

```
...
//SYSIN DD *
IEFOPZ SEL_STATE=INACTIVE SEL_ARCH=10 LIST=HLQ.OUT.ARCH10.LIST
IEFOPZ SEL_STATE=INACTIVE SEL_ARCH=11 LIST=HLQ.OUT.ARCH11.LIST
```

Example 4. Restricting optimization using the SEL_OLD selector

The following example produces optimized modules for members of OLD data sets that match given patterns.

In the first line, optimized modules will be produced for all members of HLQ.IN.LOAD.

In the second line, optimized modules will be produced for data set members that match M* in OLD data sets matching HLQ.IN.*. REPLACE=N is specified on the second line to avoid re-optimizing modules from the first line.

```
...
//SYSIN DD *
IEFOPZ SEL_OLD=HLQ.IN.LOAD
IEFOPZ SEL_OLD=HLQ.IN*.*(M*) REPLACE=N
```

Recommended settings for the z/OS JCL REGION and JCL MEMLIMIT parameters

ABO optimization techniques

To generate high performing optimized modules, beyond those possible from Enterprise COBOL V4 and earlier, ABO performs advanced analysis and uses code optimization techniques that require substantial machine resources.

In addition, since ABO is easily invoked on many compiled programs at once, the overall resources can be high due to the amount of processing requested. An entire data set, potentially composed of many modules, where each module can itself contain many compiled programs (CSECTs), can be optimized in bulk using ABO. Therefore, the total resources required by ABO for optimizing hundreds or thousands of compiled programs at once will be higher compared to a compilation process that is operating on a single source file at a time.

The time and memory required to optimize a module is based on the following factors:

- The number of CSECTs in the module.
- The complexity of each CSECT. Complexity is impacted by both the size of the compiled PROCEDURE DIVISION statements and also by the size of the input program's DATA DIVISION.

Setting the z/OS JCL REGION and JCL MEMLIMIT parameters appropriately

As shown in the [Appendix A, "JCL sample,"](#) on page 63, the JCL REGION parameter should be set to 0M to allow ABO the memory it requires to operate.

ABO will use storage above the 2 GB BAR to optimize large CSECTs. This means that the z/OS MEMLIMIT parameter should be set to a high enough value in order to allow ABO processing to complete successfully.

The recommended REGION setting of 0M will set MEMLIMIT to NOLIMIT. However, this NOLIMIT value may have been overridden to a lower value by a MEMLIMIT setting on JOB or EXEC statements or by the exit routine IEFUSI. The amount of storage required by ABO will depend on the number and size of CSECTs being optimized.

If MEMLIMIT=NOLIMIT has been overridden to a lower value and this MEMLIMIT setting is not high enough, you may get one of these ABO messages:

```
BOZ1145U Insufficient memory in the compiler to continue compilation.
BOZ1428U Insufficient memory encountered during binder API "&1": return code=&2
         reason code=&3. Terminating optimizer.
BOZ1449U Unhandled out of memory exception
```

A MEMLIMIT setting of 10GB or more may be required for optimizing very large CSECTs, or a high number of smaller CSECTs. If any of the ABO BOZ1145U, BOZ1428U or BOZ1449U messages are encountered then increase the MEMLIMIT setting to a higher value.

For more information on JCL REGION and JCL MEMLIMIT parameters, see the [z/OS MVS Initialization and Tuning Reference](#) and the [z/OS MVS Initialization and Tuning Guide](#).

Specifying the language to be used for ABO messages

The CEEOPTS DD is used to specify the language for ABO produced messages.

By default, messages are in English. To specify that you want Japanese messages, add the following code to your JCL:

```
//CEE0PTS DD *
           NATLANG(JPN)
/*
```

Invoking ABO from TSO, REXX and assembler code

This section describes how to invoke ABO from TSO, REXX and the assembler.

Optimizing under TSO

Under TSO, you can use TSO commands, command lists (CLISTs), REXX execs, or ISPF to optimize COBOL programs using traditional MVS data sets. You can use TSO commands or REXX execs to optimize programs using z/OS UNIX files.

With each method, you need to allocate the data sets and request the optimization following these steps:

1. Use the ALLOCATE command to allocate data sets. You can allocate data sets in any order. However, you must allocate all needed data sets before you start to optimize.
2. Provide the optimizer parameters within your SYSIN data set.
3. Use the CALL command at the READY prompt to request optimization:
CALL 'h1qboz.SBOZMOD1(BOZOPT)'

You can specify the ALLOCATE and CALL commands on the TSO command line, or, if you are not using z/OS UNIX files, you can include them in a CLIST.

You can allocate z/OS UNIX files for all the optimizer data sets if they are not PDS or PDSE libraries. For example, if ABO parameters are stored in the UNIX file /u/myu/abo.parms, then the ALLOCATE statements have the following form:

```
Allocate File(SYSIN) Path('/u/myu/abo.parms') Pathopts(ORDONLY) Filedata(TEXT)
```

ALLOCATE and CALL for optimizing under TSO

The following example shows how to specify the ALLOCATE and CALL commands when you are optimizing under TSO. Notice that all the files can be either new or existing ones, except the input files SYSIN and SYSBIN that must exist before optimization starts.

```
[READY]
FREE F(SYSPRINT SYSIN OPTLOG OPTERR CEEDUMP SYSBIN
SYSBOUT)
[READY]
ALLOC F(SYSPRINT) DA(ABO.LISTING) SPACE(10,10) CYL NEW CATALOG RECFM(V B) LRECL(512)
BLKSIZE(27998) DSORG(PS)
[READY]
ALLOC FI(OPTLOG) DA(ABO.OPTLOG) SPACE(10,10) CYL NEW CATALOG RECFM(V B) LRECL(512)
BLKSIZE(27998) DSORG(PS)
[READY]
ALLOC FI(OPTERR) DA(ABO.OPTERR) SPACE(10,10) CYL NEW CATALOG RECFM(V B) LRECL(512)
BLKSIZE(27998) DSORG(PS)
[READY]
ALLOC FI(CEEDUMP) DA(ABO.CEEDUMP) SPACE(50,10) CYL NEW CATALOG RECFM(F B) LRECL(133)
BLKSIZE(27930) DSORG(PS)
[READY]
ALLOC FI(SYSIN) DA(ABO.SYSIN) SHR           /* supply ABO parameters within SYSIN file
*/
[READY]
ALLOC FI(SYSBIN) DA(IN.LOAD) SHR           /* supply COBOL load library to be optimized */
[READY]
ALLOC FI(SYSBOUT) DA(OUT.LOAD) SHR        /* supply load library for optimized load modules */
[READY]
CALL 'h1qboz.SBOZMOD1(BOZOPT)'
[READY]
FREE F(SYSPRINT SYSIN OPTLOG OPTERR CEEDUMP SYSBIN SYSBOUT)
```

CLIST for optimizing under TSO

The following example shows a CLIST for optimizing under TSO:

```
PROC 1 HLQBOZ
FREE F(SYSPRINT SYSIN OPTLOG OPTERR CEEDUMP SYSBIN
SYSBOUT)
ALLOC FI(SYSPRINT) DA(ABO.LISTING) SHR
ALLOC FI(SYSIN) UNIT(SYSDA) SPACE(1,0) TRACKS NEW +
RECFM(F B) LRECL(80) BLKSIZE(800) DSORG(PS)
OPENFILE SYSIN OUTPUT
SET SYSIN = &STR(BOPT IN=DD:SYSBIN(MEMBER) OUT=DD:SYSBOUT(MEMBER))
PUTFILE SYSIN
CLOSEFILE SYSIN
ALLOC FI(OPTLOG) DA(ABO.OPTLOG) SHR
ALLOC FI(OPTERR) DA(ABO.OPTERR) SHR
ALLOC FI(CEEDUMP) DA(ABO.CEEDUMP) SHR
ALLOC FI(SYSBIN) DA(IN.LOAD) SHR
ALLOC FI(SYSBOUT) DA(OUT.LOAD) SHR
CALL '&HLQBOZ..SBOZMOD1(BOZOPT)'
FREE F(SYSIN SYSPRINT OPTLOG OPTERR CEEDUMP SYSBIN SYSBOUT)
```

REXX for optimizing under TSO

The following example shows a REXX for optimizing under TSO:

```
/*=====*>> REXX <<=====*/
Parse Arg hlqboz . /* get argument */
IF HLQBOZ = '' THEN DO
SAY 'HLQBOZ ARGUMENT MISSING'
EXIT
END
ADDRESS TSO
msgstat = MSG("OFF")
"FREE FILE (SYSIN SYSPRINT)"
"ALLOC FI(SYSPRINT) DA(ABO.LISTING) SHR"
"ALLOC FI(OPTLOG) DA(ABO.OPTLOG) SHR"
"ALLOC FI(OPTERR) DA(ABO.OPTERR) SHR"
"ALLOC FI(CEEDUMP) DA(ABO.CEEDUMP) SHR"
"ALLOC FI(SYSBIN) DA(IN.LOAD) SHR"
"ALLOC FI(SYSBOUT) DA(OUT.LOAD) SHR"
"ALLOC FI(SYSIN) NEW CYL SPACE(1,1) RECFM(F B)",
" LRECL(80) BLKSIZE(800) DSORG(PS)"
line.1 = 'ARCH=11'
line.2 = 'BOPT IN=DD:SYSBIN(MEMBER) OUT=DD:SYSBOUT(MEMBER)'
"EXECIO 2 DISKW SYSIN (STEM line. FINIS"
"CALL '&hlqboz..SBOZMOD1(BOZOPT)'"
"FREE FI(OPTLOG OPTERR CEEDUMP SYSPRINT SYSBIN SYSBOUT SYSIN)"
msgstat = MSG("ON")
```

REXX for optimizing under TSO batch, directing OPTLOG and SYSPRINT output to the library members.

Sometimes you may need to optimize every member of the entire load library or even more than one load library without having to type multiple BOPT statements.

The following example shows a TSO batch job used to run ABOMEMBS REXX located in the data set referenced by the SYSEXEC DD name. ABOMEMBS goes through the SYSBIN data sets concatenation and individually optimizes every data set member found in that concatenation.

```
//OPTMEMBS EXEC PGM=IKJEFT01,PARM='ABOMEMBS',
REGION=0M
//STEPLIB DD DISP=SHR,DSN= hlqboz.SBOZMOD1
//SYSEXEC DD DISP=SHR,DSN=hlq.CLIST /* supply ABOMEMBS REXX member within SYSEXEC
library */
//SYSTSPRT DD SYSOUT=*,DCB=(LRECL=132,RECFM=FBA,BLKSIZE=1320)
//SYSTSN DD DUMMY
//OPTERR DD SYSOUT=*
//CEEDUMP DD SYSOUT=*
//SYSBIN DD DISP=SHR,DSN=hlq.INLOAD1 /* supply one or more COBOL load libraries to be
optimized */
// DD DISP=SHR,DSN=hlq.INLOAD2
// DD DISP=SHR,DSN=hlq.INLOAD3
//SYSBOUT DD DISP=SHR,DSN=hlq.OUTLOAD
//OPTLOG DD DISP=(,CATLG),DSN=hlq.OPTLOG,UNIT=3390, /* supply new or existing PDS/PDSE or
```

```

SEQ file */
//          SPACE=(CYL,(5,5,20)),DSNTYPE=LIBRARY,
//          DCB=(RECFM=VB,LRECL=512,BLKSIZE=0)
//SYSPRINT DD  DISP=(,CATLG),DSN=hlq.SYSPRINT,UNIT=3390, /* supply new or existing PDS/PDSE or
SEQ file */
//          SPACE=(CYL,(5,5,20)),DSNTYPE=LIBRARY,
//          DCB=(RECFM=VB,LRECL=512,BLKSIZE=0)
//SYSIN    DD *
  ARCH=11
  SCAN=N
# optionally put BOPTs below this line for specific library members optimization
  BOPT IN=hlq.INLOAD7(A*) OUT=hlq.OUTLOAD LOG=hlq.OPTLOG LIST=hlq.SYSPRINT
/*

```

For every member found in the above SYSBIN DD concatenation, ABOMEMBS invokes ABO with SYSIN, OPTLOG, SYSBIN and SYSPRINT files individually allocated for that member.

For example, for member MEM1 located in the hlq.INLOAD1 data set, it will allocate the SYSBIN file hlq.INLOAD1, reallocate the OPTLOG file hlq.OPTLOG(MEM1) and the SYSPRINT file hlq.SYSPRINT(MEM1), if the OPTLOG and SYSPRINT files allocated in the above JCL are PDS or PDSE data sets. Otherwise, it will keep using JCL allocation of these files.

To construct the SYSIN file for MEM1, it will use all the ABO parameters listed in the above JCL SYSIN file down to the first BOPT statement, and then append it with internally generated BOPT statement. Here is an example of the SYSIN file for MEM1:

```

=====
ARCH=11
SCAN=N
BOPT IN=DD:SYSBIN(MEM1) OUT=DD:SYSBOUT(MEM1)
=====

```

After all the individual SYSIN, OPTLOG, SYSPRINT and SYSBIN files are allocated, ABO is invoked to optimize MEM1.

ABOMEMBS exec repeats this process for every member in the SYSBIN concatenation. If the BOPT statement is present in the above JCL SYSIN file, after all the members in the SYSBIN concatenation are optimized, ABOMEMBS reallocates the OPTLOG and SYSPRINT files to SYSOUT, reallocates the SYSIN file containing all the same statement as the original JCL SYSIN file, and invokes ABO one more time to proceed with the parameters explicitly specified in the SYSIN file.

This approach can be useful to optimize all the library members just by including it into the SYSBIN concatenation, without having to specify any additional BOPT explicitly, and optionally, including an additional BOPT statement when you need to optimize some members of the library only. The JCL cards in the above JCL can be in any order.

ABOMEMBS generates the following SYSTSPRT output:

```

===== Processing hlq.INLOAD1 data set =====
Member ADD10 processed, rc=4
Member CALLEE processed, rc=0
Member CALLEE1 processed, rc=0
...
===== Processing hlq.INLOAD2 data set =====
Member COBPGM processed, rc=0
Member DJSIEV85 processed, rc=0
Member IAMASM processed, rc=4
...
===== Processing hlq.INLOAD3 data set =====
Member TEMPNAM6 processed, rc=12
Member TEMPNAM7 processed, rc=0
Member TEMPNAM8 processed, rc=0
...
===== Processing SYSIN statements =====
ARCH=11
SCAN=N
BOPT IN=hlq.INLOAD7(A*) OUT=hlq.OUTLOAD LOG=hlq.OPTLOG LIST=hlq.SYSPRINT
=====
READY
END

```

The following is an example of the ABOMEMBS REXX source code:

```

BROWSE    hlq.CLIST(ABOMEMBS)
Command ==>
***** Top of Data
/*=====> REXX <=====*/
Parse Arg

X = LISTDSI(STEPLIB FILE)
If x > 0 Then Do
    Say 'Check STEPLIB allocation' ; Exit
End
optimizer = ""||SYSDSNAME||'(BOZOPT)'||""
flaglog = 0 /* assume OPTLOG is sequential */
X = LISTDSI(OPTLOG FILE)
IF x = 0 & SYSDSORG = 'PO' Then Do
    optlogds = SYSDSNAME ; flaglog = 1
End
flaglist = 0 /* assume SYSPRINT is sequential */
X = LISTDSI(SYSPRINT FILE)
IF x = 0 & SYSDSORG = 'PO' Then Do
    sysprt ds = SYSDSNAME ; flaglist = 1
End
"EXECIO * DISKR SYSIN (STEM line. FINIS" /* read in SYSIN parameters into
line. array */
n = line.0 + 1 /* assume no explicit BOPT specified. n is per-member BOPT
line number */
Do l = 1 To
line.0
    PARSE UPPER VALUE line.l WITH
line.l
    If POS('BOPT ',line.l) > 0 Then
Do
    n = l ; flagbopt = 1 ; leave /* leave when first BOPT found
*/
End
    linea.l = line.l /* copy all lines before first BOPT into linea. array
*/
End
X = LISTDSI(SYSBIN
FILE)
If x > 0 Then
Do
    Say 'Check SYSBIN allocation' ;
Exit
End
x =
outtrap(concatl.)
lista
status
x =
outtrap(off)
/* i2 is a line with last dsn in SYSBIN concatenation
*/
i2 = concatl.0 - 1 /* assume that SYSBIN concatenation is a last in JCL
*/
Do i = 1 To
concatl.0
    If substr(concatl.i,3,6) = 'SYSBIN' Then
Do
    i1 = i - 1 ; leave /* i1 line with first dsn in concatenation
*/
End
End
End
k = i + 2
If k < concatl.0 Then Do

```



```

    Do i = k To concatl.0 by 2
      If substr(concatl.i,3,1) <> ' ' Then Do
        i2 = i - 3 ; leave /* i2 line with last dsn in concatenation */
      End
    End
  End
End
Else i2 = i1          /* when SYSBIN DD with a single data set is a last JCL card
*/

msgstat = MSG("OFF")

Do i = i1 To i2 by 2  /* loop trough SYSBIN concatenation */
sysbinds = strip(concatl.i)
Say '==== Processing 'sysbinds' data set ====='
x=outtrap('row.')
  Address TSO "LISTDS '"sysbinds'" members"
x=outtrap('off')
If row.0 < 6 Then Do
  Say 'Check SYSBIN file' ; Exit
End
DO J = 7 TO row.0    /* loop trough member list */
  PARSE VALUE row.J WITH memn alias
  "FREE FI(SYSIN)"
  "ALLOC FI(SYSIN) NEW CYL SPACE(1,1) RECFM(F B)",
  " LRECL(80) BLKSIZE(800) DSORG(PS)"
  linea.n = 'BOPT IN=DD:SYSBIN('||memn||') ',
  'OUT=DD:SYSBOUT('||memn||')'
  "EXECIO * DISKW SYSIN (STEM linea. FINIS"
  If flaglog = 1 Then Do
    "FREE FI(OPTLOG)"
    optlogm = "' '||optlogds||'('||memn||')' ||'"
    "ALLOC FI(OPTLOG) DA("optlogm") SHR"
  End
  If flaglist = 1 Then Do
    "FREE FI(SYSPRINT)"
    sysprtm = "' '||sysprtds||'('||memn||')' ||'"
    "ALLOC FI(SYSPRINT) DA("sysprtm") SHR"
  End
  "FREE FI(SYSBIN)"
  "ALLOC FI(SYSBIN) DA('"sysbinds"') SHR"
  "CALL "optimizer /* optimize member */
  Say 'Member 'memn' processed, rc='rc
END /* end of member list loop */
End /* end of concatenation list loop */
If flagbopt = 1 Then Do
  "FREE FI(SYSIN)"
  "ALLOC FI(SYSIN) NEW CYL SPACE(1,1) RECFM(F B)",
  " LRECL(80) BLKSIZE(800) DSORG(PS)"
  "EXECIO * DISKW SYSIN (STEM line. FINIS"
  "FREE FI(OPTLOG)"
  "ALLOC FI(OPTLOG) SYSOUT"
  "FREE FI(SYSPRINT)"
  "ALLOC FI(SYSPRINT) SYSOUT"
  "CALL "optimizer /* optimize with BOPTs provided in SYSIN */
  Say '==== Processing SYSIN statements ====='
  Do i = 1 To line.0
    Say line.i
  End
  Say '====='
End
msgstat = MSG("ON")
EXIT

```

Starting the optimizer from an assembler program

You can invoke ABO programmatically from within an HLASM program.

Before you start to optimize, complete these steps:

1. Allocate all the needed data sets, either by using dynamic allocation within your assembler program or specifying the DD cards in the job JCL used for your assembler program invocation. The following DD names must be allocated: SYSPRINT, SYSBIN, SYSBOUT, SYSIN, OPTLOG, OPTERR, CEEDUMP.
2. Provide the ABO parameters within your SYSIN data set.

You can start ABO from within an assembler program by using the LINKX or ATTACHX macro because those two are 64 bit mode compatible and ABO is running in AMODE 64.

The following is an example of the LINKX macro in list form:

```
symbol {LINKX} EP=BOZOPT,AMODE64OK=YES,PLIST8=YES,SF=L
```

The following is an example of the LINKX macro in execute form:

```
LINKX EP=BOZOPT,AMODE64OK=YES,PARAM=(addr),PLIST8=YES,      *
      MF=(E,#LINKX),SF=(E,#LINK2)
```

where # is used as a prefix symbol.

EP

Specifies the symbolic name of ABO.

PARAM

Specifies the address parameters list to be passed from the assembler program to ABO. In the example, *addr* can be any value because it's ignored by BOZOPT program which directly reads parameters supplied in the SYSIN file.

PLIST8=YES

Defines the size of the parameter list entries for a parameter list to be built by LINKX based on the PARAM keyword, as an 8-bytes-per-entry parameter list.

AMODE64OK=YES

Indicates that the system is to accept an attempt to link to an AMODE 64 target routine from an AMODE 24 or AMODE 31 routine.

SF=L

Specifies the list form of the LINKX macro.

When ABO completes processing, it puts a return code in register 15.

Assembler program starting the optimizer

The following example shows the ABO invocation from an assembler program:

```
//JOB CARD JOB
//*
//ASM HCL PROC MAC='SYS1.MACLIB',MAC1='SYS1.MODGEN',U=3390,
//          MAC2='SYS1.MACLIB'
//*-----***
//*          A S M H C L          H-ASSEMBLER          ***
//*          IBM-PROCEDURE:  COMPILER + LINK          ***
//*-----***
//ASM      EXEC  PGM=ASMA90,PARM=OBJECT,REGION=0M
//SYSLIB   DD    DSN=&MAC,DISP=SHR
//          DD    DSN=&MAC1,DISP=SHR
//          DD    DSN=&MAC2,DISP=SHR
//SYSUT1   DD    DSN=&&SYSUT1,UNIT=&U,SPACE=(TRK,(60,45))
//SYSPRINT DD    SYSOUT=*,DCB=BLKSIZE=1089
//SYSPUNCH DD    DUMMY
//SYSLIN   DD    DSN=&&OBJSET,UNIT=&U,SPACE=(80,(2000,500)),
//          DISP=(MOD,PASS)
//LKED     EXEC  PGM=HEWLH096,
//          PARM='XREF,LET,LIST,AC=0,FILL=NONE',
//          COND=(8,LT,ASM)
//SYSLIN   DD    DSN=&&OBJSET,DISP=(OLD,DELETE)
//          DD    DDNAME=SYSIN
//SYSLMOD  DD    DSN=h1q.CALLABO.LOAD,DISP=SHR
//SYSUT1   DD    DSN=&&SYSUT1,UNIT=(&U,SEP=(SYSLIN,SYSLMOD)),
//          SPACE=(1024,(50,20))
//SYSPRINT DD    SYSOUT=*
//          PEND
```

```

//*
// EXEC ASMHCL
//ASM.SYSIN DD
*
YREGS
CALLABO CSECT
CALLABO AMODE 31
CALLABO RMODE ANY
STM R14,R12,12(R13)
USING CALLABO,R12
LR R12,R15 LOAD BASE REGISTER
LA R9,SAVE POINT TO CURRENT SAVEAREA
ST R9,8(,R13) A(CURRENT_SA) IN OLD_SA
ST R13,4(,R9) A(OLD_SA) IN CURRENT_SA
LR R13,R9 R13=A(CURRENT_SAVEAREA)
*-----*
LLGTR R12,R12 allow 64-bit
addressability
BAL R14,LINKOPT invoke BOZOPT
*-----*
DONE DS 0H
L R13,4(,R13)
ST R15,16(,R13)
LM R14,R12,12(R13)
BR R14
*-----*
LINKOPT DS 0H
XR R15,R15 nullify parm addr, BOZOPT ignores
it
LLGTR R15,R15
SAM64
LINKX EP=BOZOPT,AMODE640K=YES,PARAM=((R15)),PLIST8=YES, *
MF=(E,#LINKX),SF=(E,#LINK2)
SAM31
B DONE
*-----*
SAVE DS 0F
DC XL72'00'
#LINKX LINKX EP=BOZOPT,AMODE640K=YES,PLIST8=YES,SF=L
#LINK2 LINKX EP=BOZOPT,AMODE640K=YES,PLIST8=YES,SF=L
LTOrg
END
//LKED.SYSIN DD *
PAGE CALLABO
NAME CALLABO(R)
//

```

The following is a sample JCL to run the CALLABO program:

```

//OPT EXEC PGM=CALLABO,REGION=0M
//STEPLIB DD DSN=h1qboz.SBOZMOD1,DISP=SHR
// DD DSN=h1q.CALLABO.LOAD,DISP=SHR
//OPTLOG DD SYSOUT=*
//OPTERR DD SYSOUT=*
//CEEDUMP DD SYSOUT=*
//SYSPRINT DD SYSOUT=*
//SYSBIN DD DSN=h1q.IN.LOAD,DISP=SHR
//SYSBOUT DD DSN=h1q.OUT.LOAD,DISP=SHR
//SYSIN DD *
# supply ABO directives down this line
BOPT IN=DD:SYSBIN(*) OUT=DD:SYSBOUT

```

Chapter 6. Understanding output from the optimization process

Log files

IBM Automatic Binary Optimizer for z/OS generates a log file that helps you identify and resolve problems.

You can diagnose problems at optimize time by inspecting the log file that is generated unconditionally by ABO into the OPTLOG DD (see [Table 6 on page 15](#)). The log file contains diagnostic information about optimization and scanning.

To generate additional member-level log files, use the [LOG option](#).

The log file for optimization

When optimization is performed on a module (SCAN=N optimizer option is in effect), the log file includes the following information:

- File name information of the input module being processed
- Names of the CSECTs being optimized
- File name information of the listing transform for each optimized CSECT
- File name information of the output optimized module
- A time stamp for each line of the OPTLOG and a header for the date
- Other diagnostic information including error messages

Example 1:

The following log file shows COBOL CSECTs from members MEMA and MEMB of data set *HLQ.IN1.LOAD* are being optimized. Module MEMA has two COBOL CSECTs named SUB1 and SUB2 that are optimized. Module MEMB has one COBOL CSECT named PROGB that is optimized. Listing transforms are all placed in the default SYSPRINT DD. Optimized modules are written to the *HLQ.OUT1.LOAD* data set.

```
5697-AB1 IBM Automatic Binary Optimizer for z/OS 1.3.0

===== Sept 24 2018 =====
10:53:16 Optimizer build level: tr_r17_binopt_20180924_141188 (Sept 24 2017 14:05:42)
10:53:16 Processing HLQ.IN1.LOAD, member MEMA
10:53:16   Processing CSECT SUB1, in member MEMA
10:53:16     Optimizing CSECT SUB1 for zEC12
10:53:16     Succeeded in optimizing SUB1
10:53:16     Generating listing transform into DD:SYSPRINT
10:53:16   Processing CSECT SUB2, in member MEMA
10:53:16     Optimizing CSECT SUB2 for zEC12
10:53:16     Succeeded in optimizing SUB2
10:53:16     Generating listing transform into DD:SYSPRINT
10:53:16   Finished processing, processed 2 of 2 CSECTs in member MEMA
10:53:16   Save HLQ.OUT1.LOAD (MEMA) succeeded
10:53:16 Processing HLQ.IN1.LOAD, member MEMB
10:53:16   Processing CSECT PROGB, in member MEMB
10:53:16     Optimizing CSECT PROGB for zEC12
10:53:16     Succeeded in optimizing PROGB
10:53:16     Generating listing transform into DD:SYSPRINT
10:53:16   Finished processing, processed 1 of 1 CSECTs in member MEMB
10:53:16   Save HLQ.OUT1.LOAD (MEMB) succeeded
10:53:16 Exiting with return code: 0
```

Example 2:

The following log files show the output for the member-level log files produced by the same *HLQ.IN1.LOAD* as the previous example with *LOG=HLQ.LOG.OUT* specified.

The contents of *HLQ.LOG.OUT(MEMA)*:

```
5697-AB1 IBM Automatic Binary Optimizer for z/OS 1.3.0
===== Sept 24 2018 =====
10:53:16 Optimizer build level: tr_r17_binopt_20180924_141188 (Sept 24 2018 14:05:42)
10:53:16 Processing HLQ.IN1.LOAD, member MEMA
10:53:16   Processing CSECT SUB1, in member MEMA
10:53:16     Optimizing CSECT SUB1 for zEC12
10:53:16     Succeeded in optimizing SUB1
10:53:16     Generating listing transform into DD:SYSPRINT
10:53:16   Processing CSECT SUB2, in member MEMA
10:53:16     Optimizing CSECT SUB2 for zEC12
10:53:16     Succeeded in optimizing SUB2
10:53:16     Generating listing transform into DD:SYSPRINT
10:53:16   Finished processing, processed 2 of 2 CSECTs in member MEMA
10:53:16   Save HLQ.OUT1.LOAD (MEMA) succeeded
10:53:16   Exiting with return code: 0
```

The contents of *HLQ.LOG.OUT(MEMB)*:

```
5697-AB1 IBM Automatic Binary Optimizer for z/OS 1.3.0
===== Sept 24 2018 =====
10:53:16 Optimizer build level: tr_r17_binopt_20180924_141188 (Sept 24 2018 14:05:42)
10:53:16 Processing HLQ.IN1.LOAD, member MEMB
10:53:16   Processing CSECT PROGB, in member MEMB
10:53:16     Optimizing CSECT PROGB for zEC12
10:53:16     Succeeded in optimizing PROGB
10:53:16     Generating listing transform into DD:SYSPRINT
10:53:16   Finished processing, processed 1 of 1 CSECTs in member MEMB
10:53:16   Save HLQ.OUT1.LOAD (MEMB) succeeded
10:53:16   Exiting with return code: 0
```

The log file for scanning

When scanning is performed (*SCAN=Y* optimizer option is in effect), the log file shows:

- File name information of the input module being scanned
- Names of the CSECT of the module being scanned
- Other diagnostic messages

Example:

The following log file shows modules *MEMA* and *MEMB* of data set *HLQ.MEM1.LOAD* are being scanned. Scanning output shows each of the CSECTs in the modules. The COBOL compiler version used for the compilation and the "Signature information bytes" extracted from the CSECT are displayed for the COBOL CSECTs *SUB*, *SUB2* and *PROGB*. "Signature information bytes" are documented in the *COBOL Programming Guide* and provide information about the compiled program.

```
5697-AB1 IBM Automatic Binary Optimizer for z/OS 1.3.0
===== Sept 24 2018 =====
10:58:23 Optimizer build level: tr_r17_binopt_20180924_141188 (Sept 24 2018 14:05:42)
10:58:23 Processing HLQ.IN1.LOAD, member MEMA
  Language ID Records:
    id 5688187 v21 m00 2015281 resident EDCOEXTS
    id 5655S7100 v42 m00 2015281 resident SUB
  Enterprise COBOL V4: start=0x10, length=4.19 (kBytes)
    Signature information bytes:
    a0487d4c 20000000 00880100 00000040
    08000000 000000 00008004 1400
    id 5655S7100 v42 m00 2015281 resident SUB2
  Enterprise COBOL V4: start=0x10d8, length=4.20 (kBytes)
    Signature information bytes:
    a0487d4c 20000000 00880100 00000040
    08000000 000000 00008004 1400
    id 569623400 v01 m06 2013071 resident CEESG005
```

```

id 569623400 v01 m06 2013072 resident CEEBETBL
id 569623400 v01 m06 2013072 resident CEESTART
10:58:23 Processing HLQ.IN1.LOAD, member MEMB
Language ID Records:
id 5688187 v21 m00 2015281 resident EDCOEXTS
id 5655S7100 v42 m00 2015281 resident PROGB
Enterprise COBOL V4: start=0x10, length=8.19 (kBytes)
Signature information bytes:
a0487d4c 20000000 00880100 00000040
08000000 000000 00008004 1400
id 569623400 v01 m06 2013072 resident CEESTART
10:58:23 Exiting with return code: 0

```

Listing transform

The listing transform describes the changes made by the Automatic Binary Optimizer for z/OS to your already compiled program module. It shows how the instructions in the input binary map to the optimized instructions. A listing transform is produced for every CSECT that is optimized. The listing transform is intended to complement the compiler listing generated when the input binary was originally compiled from source. While the listing transform does not depend on the compiler listing, using the two together will allow you to better understand how IBM Automatic Binary Optimizer for z/OS transformed your binary.

A listing transform is generated unconditionally for every optimized CSECT; no special options or flags need to be specified. By default, listing transforms are generated into the SYSPRINT DD.

The listing transform is also used by [“Application Delivery Foundation for z Systems”](#) on page 58.

Listing transform contents

The listing transform is provided to help in diagnosing problems encountered during the execution of the optimized program. The listing transform is primarily intended for use by debugging tools such as IBM Debug for z Systems.

A listing transform contains the following information:

- A summary of the optimization options
- The optimized instructions interspersed with the input instructions
- A literal pool containing any new literals created by ABO
- A PPA4 section containing information about the optimized CSECT
- An automatic map, also known as a dynamic storage area (DSA) map, of any new stack symbols that were created by ABO
- An input instructions section containing the complete list of instructions and compiler options for the CSECT being optimized

Summary of optimization parameters

This section contains the name of the architecture level for which the program is optimized, and the date and time stamp of both the input binary, along with the compiler used to produce it. The date and time stamp of the output binary is also shown.

Example:

```

Invocation Parameters:
Architecture Level: zEC12

Input IDRL Record: 5655S7100 v42 m00 2013122
Name: Enterprise COBOL V4
Version: 42
Mod Level: 00

```

Compiled Date (YYYYDDD): 2013122

Output IDRL Record: 5697-AB1 v13 m00 2017213
Name: IBM Automatic Binary Optimizer for z/OS
Version: 13
Mod Level: 00
Optimized Date (YYYYDDD): 2017213

Optimized instructions

This section makes up the majority of the data in the listings transform. It is similar to the object code section of the listings generated by various IBM COBOL compilers, such as IBM Enterprise COBOL V5 and V6. Each CSECT that was optimized begins with the PROC pseudo opcode and the name of the CSECT as its operand.

Example:

(1)	(2)	(3)	(4)	(5)
000258		000000	PROC	PROGA
000258	183F	000000	LR	R3,R15
00025A	5800 3008	000000	L	R0, 8(,R3)
00025E	1E01	000000	ALR	R0,R1
000260	5500 C00C	000000	CL	R0, 12(,R12)
000264	0DF0	000000	BASR	R15,R0
000266	47D0 F00C	000000	BC	R13, 12(,R15)
00026A	58F0 C300	000000	L	R15, 768(,R12)
00026E	0DEF	000000	BASR	R14,R15
000270	181F	000000	LR	R1,R15
000272	50D0 1004	000000	ST	R13, 4(,R1)
000276	5000 104C	000000	ST	R0, 76(,R1)
00027A	D203 1000 3058	000000	MVC	0(4,R1), 88(R3)
000280	D703 1084 1084	000000	XC	132(4,R1), 132(R1)
000286	5090 105C	000000	ST	R9, 92(,R1)
00028A	18D1	000000	LR	R13,R1
00028C	41A0 D120	000000	LA	R10, 288(,R13)

The preceding example shows the optimized instructions produced for a CSECT named PROGA. The five sections of an optimized instruction are described as follows:

1. The hexadecimal offset in the CSECT of the optimized instruction
2. The hexadecimal representation of the instruction bytes
3. The hexadecimal CSECT offset of the "source" instructions for which these optimized instructions were generated
4. Instruction opcode
5. Instruction operands

Interspersed with the optimized instructions are the "source" instructions for which the optimized instructions are generated. Lines that begin in column 5 are the optimized instructions, and the lines that begin in column 1 are the "source" instructions. In the following example, the first two lines, starting at column 1, are the PACK and OI source instructions at hex offsets 00042C and 000432 respectively. The third line, starting in column 5, is the ABO generated instruction 'CDZT'. Notice that the "source" hex offset of the CDZT is 00042c, which shows that it was generated for the PACK instruction in the input module.

Example:

00042C	PACK	272(4,13),0(7,8)			
000432	OI	276(13),15			
000434	ED07	4000 00AA	00042C	CDZT	FP0,_WSA[0x12c] 0(8,R4),0x0
000436	PACK	280(4,13),8(7,8)			
00043C	OI	284(13),15			
00043E	ED07	4008 10AA	000436	CDZT	FP1,_WSA[0x12c] 8(8,R4),0x0
000440	AP	272(4,13),280(4,13)			
000446	UNPK	16(7,8),272(4,13)			
000448	B3D2	1000	000440	ADTR	FP0,FP0,FP1
00044C	OI	23(8),240			

```
000450 L 2,248(0,,13)
0004D4 ED07 4010 00A8 00044C CZDT FP0, 16(8,R4),0x0
```

The literal pool

ABO places any new literals it creates at the end of the code section. These sections are named *Constant Data Snippets* in the listing transform. There may be zero or more Constant Data Snippets in the listing and their contents are very similar to the literal pool that is created by the original compiler. The original literal pool remains intact and continues to be used, just as in the input binary.

Example:

(1)	(2)	(3)	(4)
		L0032:	# Constant Data Snippet
000550	4040 4040 4040 4040	DC	X'4040404040404040'
000558	4040 4040 4040 4040	DC	X'4040404040404040'
000560	4040 4040 4040 4040	DC	X'4040404040404040'
000568	4040 4040 4040 0000	DC	X'4040404040400000'
000570	8000 0000 0000 0000	DC	X'8000000000000000'
000578	0000 0000 0000 0000	DC	X'0000000000000000'
000580	0000 0001 0000 0000	DC	X'0000000100000000'
000588	C9C7 E9E2 D9E3 C3C4	DC	X'C9C7E9E2D9E3C3C4'
000590	E2E8 E2D6 E4E3 4040	DC	X'E2E8E2D6E4E34040'
000598	0E00 0000 0000 0000	DC	X'0E00000000000000'

A description of the four sections of data is as follows:

1. The hexadecimal offset from the start of the CSECT to these bytes in the literal pool
2. The hexadecimal representation of the bytes in the literal pool
3. The label denoting the start of the literal pool
4. Assembler syntax of these bytes

Additional DSA and TGT Bytes Allocated section

This section displays in hexadecimal number of bytes any additional DSA or TGT bytes allocated by the optimizer

Example:

```
DSA WILL BE ALLOCATED FOR AN ADDITIONAL 000001A8 BYTES
TGT WILL BE ALLOCATED FOR AN ADDITIONAL 00000000 BYTES
```

The PPA4 section

The PPA4 section contains information about the optimization of the program module. For example, it contains the time and date of optimization, the length of the code section and other information.

Example:

(1)	(2)	(3)	(4)
	PPA4: Entry Point Constants		
046668	00000000	=X'00000000'	Flags 1
04666C	00000300	=X'00000300'	Flags 2
046670	F2F0F1F6	=C'2016'	Compiled Year
046674	F0F8F2F1	=C'0821'	Compiled Date MMDD
046678	F1F2F3F0F2F3	=C'123023'	Compiled Time HHMMSS
04667E	F0F1F0F2F0F0	=C'010200'	Compiler Version
046684	0004706A	=F'290922'	Code Length
046688	0B020000	=X'0B020000'	Options
04668C	00000028	=X'00000028'	A(PPA4-ListName)
	PPA4 End		

A description of the four sections of PPA4 follows:

1. The offset in hexadecimal in the CSECT of PPA4 section entry
2. The hexadecimal representation of the bytes in the PPA4 section
3. Assembler syntax of the bytes in the PPA4
4. Description of the data in the PPA4

The automatic map

The automatic map contains the offsets and sizes (in hexadecimal) of symbols that are created by ABO. These offsets are relative to a base established at the end of the original DSA. The automatic map does not show automatics in the original program or temporaries created by the original compiler. ABO will establish a general purpose register (GPR) to contain the start offset of the "new" DSA. All newly created automatics will be referenced with this new register as the base.

Example:

(1)	(2)	(3)
OFFSET (HEX)	LENGTH (HEX)	NAME
0	4	_GPR0
4	4	_GPR1
8	4	_GPR2
C	4	_GPR3
10	4	_GPR4
14	4	_GPR5
18	4	_GPR6
1C	4	_GPR7
20	4	_GPR8
24	4	_GPR9
28	4	_GPR10
2C	4	_GPR11
30	4	_GPR12
34	4	_GPR13

A description of the three sections of the automatic map follows:

1. Hexadecimal offset of the stack symbol, relative to the start of the new stack
2. Hexadecimal length of the symbol in bytes
3. Name of the symbol

Input instructions

This section contains the complete list of instructions from the input module. There is one section for each CSECT that was optimized. These input instructions are the same as those already shown in the Optimized instructions section. In that section, the input instructions are shown interspersed with the corresponding optimized instructions, and as such are not a complete and ordered list.

The input instructions section begins with the COBOL compiler version used for the compilation and the "Signature information bytes" extracted from the CSECT. "Signature information bytes" are documented in the *COBOL Programming Guide* and provide information about the compiled program. These information bytes are decoded and the corresponding compiler options that were in effect are printed. Note that the decoded compiler options may not exactly match in content and formatting those displayed in the original compiler listing. This is because ABO decodes the options only according to the signature information bytes present in the input CSECT instead of the full original source and options specified during the original compilation process.

In the following example, the COBOL CSECT named PROGB was optimized.

(1)	(2)	(3)
*****	INPUT	INSTRUCTIONS
id 5655S7100	v42 m00	2018005 resident PROGB
Enterprise COBOL V4: start=0x10, length=9.15 (kBytes)		
Signature information bytes:		

```

a0487dcc 20000000 00880108 00000040
08000000 00000008 00f00114 00
Compiler Options in effect:
  ADV
  ARITH(COMPAT)
  NOAWO
  NOBLOCK0
  Compilation unit is a program.
  NOCICS
  NOCURRENCY
  Default DDNAME for OUTDD will be used
  DATA(31)
  NODATEPROC
  DBCS
  NODECK
  NODLL
  NODUMP
  NODYNAM
  NOEXPORTALL
  NOFASTSRT
  INTDATE(ANSI)
  NOLIB
  LIST
  NOMAP
  NOMDECK
  NONAME
  NONUM
  NUMCLS(PRIM)
  NUMPROC(NOPFD)
  OBJ
  NOOFFSET
  NOOPTIMIZE
  QUOTE
  RENT
  RMODE(ANY)
  SEQUENCE
  SIZE(MAX)
  SOURCE
  NOSQL
  SQLCCSID
  NOSSRANGE
  TERM
  TEST(HOOK,NOSEPARATE,EJPD)
  NOTHREAD
  TRUNC(STD)
  NOVBREF
  NOWORD
  XMLPARSE(XMLSS)
  XREF
  YEARWINDOW(1900)
  ZWB

```

```

0002BA LR 3,15
0002BC LA 0,440(0,,1)
0002C0 CL 0,12(0,,12)
0002C4 BASR 15,0
0002C6 BC 13,12(0,15)
0002CA L 15,768(0,,12)
0002CE BASR 14,15
0002D0 LR 1,15
0002D2 ST 13,4(0,,1)
0002D6 ST 0,76(0,,1)
0002DA MVC 0(4,1),88(3)
0002E0 XC 132(4,1),132(1)
0002E6 ST 9,92(0,,1)
0002EA LR 13,1
0002EC L 12,232(0,,9)
0002F0 LR 1,2
0002F2 ST 13,88(0,,13)
0002F6 L 10,36(0,,12)
0002FA L 8,300(0,,9)
0002FE STM 14,12,12(13)
000302 MVC 136(4,13),16(10)
000308 LA 2,280(0,,13)
00030C ST 2,140(0,,13)
000310 ICM 2,15,364(9)
000314 L 11,40(0,,12)
000318 BC 8,214(0,11)
00031C L 3,92(0,,9)
000320 L 15,244(0,,3)
000324 LA 1,271(0,,10)
000328 BASR 14,15

```

00032A	A	2,0(0,,12)
00032E	ST	2,364(0,,9)
000332	MVC	256(4,13),252(13)
000338	LA	2,240(0,,11)
00033C	ST	2,252(0,,13)
000340	BC	15,84(0,11)
000344	MVC	252(4,13),256(13)
00034A	MVC	260(4,13),248(13)
000350	L	11,40(0,,12)
000354	LA	2,268(0,,11)
000358	ST	2,248(0,,13)
00035C	BC	15,0(0,11)
000360	MVC	248(4,13),260(13)
000366	TM	87(9),64
00036A	L	11,40(0,,12)
00036E	BC	1,306(0,11)
000372	TM	84(9),32
000376	BC	14,298(0,11)
00037A	OI	132(13),32
00037E	OI	87(9),64
000382	BC	15,306(0,11)
000386	OI	348(9),64
00038A	OI	132(13),1
00038E	BAS	14,316(0,,9)
000392	BAS	14,318(0,,9)
000396	AP	0(8,8),16(8,8)
00039C	ZAP	0(8,8),0(8,8)
0003A2	BAS	14,318(0,,9)
0003A6	ZAP	16(8,8),0(8,8)
0003AC	BAS	14,318(0,,9)
0003B0	CP	0(8,8),114(2,10)
0003B6	L	11,40(0,,12)
0003BA	BC	7,392(0,11)
0003BE	BAS	14,316(0,,9)
0003C2	BAS	14,318(0,,9)
0003C6	L	2,92(0,,9)
0003CA	L	15,44(0,,2)
0003CE	LA	1,259(0,,10)
0003D2	BASR	14,15
0003D4	L	11,40(0,,12)
0003D8	BC	15,414(0,11)
0003DC	BAS	14,316(0,,9)
0003E0	BAS	14,318(0,,9)
0003E4	L	2,92(0,,9)
0003E8	L	15,44(0,,2)
0003EC	LA	1,247(0,,10)
0003F0	BASR	14,15
0003F2	BAS	14,316(0,,9)
0003F6	BAS	14,318(0,,9)
0003FA	CP	16(8,8),114(2,10)
000400	L	11,40(0,,12)
000404	BC	7,466(0,11)
000408	BAS	14,316(0,,9)
00040C	BAS	14,318(0,,9)
000410	L	2,92(0,,9)
000414	L	15,44(0,,2)
000418	LA	1,235(0,,10)
00041C	BASR	14,15
00041E	L	11,40(0,,12)
000422	BC	15,488(0,11)
000426	BAS	14,316(0,,9)
00042A	BAS	14,318(0,,9)
00042E	L	2,92(0,,9)
000432	L	15,44(0,,2)
000436	LA	1,223(0,,10)
00043A	BASR	14,15
00043C	BAS	14,316(0,,9)
000440	BAS	14,318(0,,9)
000444	BAS	14,316(0,,9)
000448	L	11,40(0,,12)
00044C	BC	15,534(0,11)
000450	BAS	14,316(0,,9)
000454	TM	132(13),32
000458	BC	14,534(0,11)
00045C	L	2,92(0,,9)
000460	L	15,244(0,,2)
000464	LA	1,205(0,,10)
000468	BASR	14,15
00046A	L	2,364(0,,9)
00046E	S	2,0(0,,12)
000472	ST	2,364(0,,9)
000476	NI	348(9),191

00047A	TM	85(9),64
00047E	BC	14,572(0,11)
000482	LA	1,8(0,,0)
000486	L	2,92(0,,9)
00048A	L	15,32(0,,2)
00048E	BASR	14,15
000490	TM	84(9),40
000494	BC	7,602(0,11)
000498	L	2,296(0,,9)
00049C	LH	15,8(0,,2)
0004A0	L	13,4(0,,13)
0004A4	L	14,12(0,,13)
0004A8	LM	0,12,20(13)
0004AC	BCR	-1,14
0004AE	MVC	264(12,13),177(10)
0004B4	L	3,296(0,,9)
0004B8	LH	2,8(0,,3)
0004BC	ST	2,276(0,,13)
0004C0	LA	1,264(0,,13)
0004C4	L	2,92(0,,9)

* * * * * E N D O F I N P U T I N S T R U C T I O N S * * * * *

A description of the three sections of the input instructions section follows:

1. The hexadecimal offset in the input CSECT of the original instruction
2. Instruction mnemonic
3. Instruction operands

SYSPRINT DD and LIST option

Use the SYSPRINT DD or LIST options to specify the locations of the generated listing transforms.

The target of SYSPRINT or LIST can be one of the following items:

- A sequential data set or member of a PDSE (not PDS). The output of multiple CSECT optimizations are added to this sequential data set in optimization order.
- A PDS or PDSE. When a CSECT is optimized, the listing transform particular to that CSECT is placed in a member of the PDS or PDSE where the member name is based on the CSECT name (upper cased and truncated to 8 characters). The contents of the member, if any, are overwritten even if the former contents are produced by ABO in previous invocations.
- An HFS path. The output of multiple CSECT optimizations are added to this HFS file.

The LIST option takes precedence over the SYSPRINT DD. If you specify the LIST option, it will override the SYSPRINT DD. When the LIST option is specified, you can omit the SYSPRINT DDname.

Example

The following JCL example uses a PDSE in the SYSPRINT DD so that listing transforms are written to the members of the PDSE.

```
//SYSIN DD *
BOPT IN=HLQ.IN.LOAD(MOD*) OUT=HLQ.OUT.LOAD
...
//SYSPRINT DD DSN=HLQ.LIST.PDSE,DISP=SHR
```

In this example, the input program modules are specified as *HLQ.IN.LOAD(MOD*)*, which means, optimize all eligible members in *HLQ.IN.LOAD* with names beginning with "MOD".

There are two members in the input data set, MOD1 and MOD2. Within these two program modules, are various CSECTS:

<i>Table 8. Input modules and their containing CSECTs</i>	
HLQ.IN.LOAD	CSECTs
MOD1	PROG1A
	PROG1B
	PROG1C
MOD2	PROG2A
	PROG2B

ABO will optimize each of these CSECTs, one at a time, and produce two outputs for each CSECT:

1. The optimized CSECT
2. The listing transform for the CSECT

The optimized CSECT has the same name as the input CSECT, and the optimized CSECT will be placed in a program module that has the same member name as the input program module. However, the new program modules will be placed into a new PDSE called '*HLQ.OUT.LOAD*'

<i>Table 9. Output 1: Optimized modules and their CSECTs</i>	
HLQ.OUT.LOAD	CSECTs
MOD1	PROG1A
	PROG1B
	PROG1C
MOD2	PROG2A
	PROG2B

The listings, generated for each of the optimized CSECT, are placed into the PDSE '*HLQ.LIST.PDSE*', as separate members. Each such PDSE member will have the same name as the input CSECT name. The results is that *HLQ.LIST.PDSE* will have 5 members, PROG1A, PROG1B, PROG1C, PROG2A and PROG2B.

<i>Table 10. Output 2: Listing transforms</i>
HLQ.LIST.PDSE
PROG1A
PROG1B
PROG1C
PROG2A
PROG2B

Chapter 7. Managing optimization and optimized module deployment process

Taking an iterative and staged approach when using ABO

An iterative and staged approach to using ABO is a recommended approach to balance the cost of the optimization process to the benefits from running the optimized programs generated by ABO.

For example, first optimize the modules containing the top x% contributors to CPU time. Measure the impact (for example, the reduction in CPU time) using these ABO generated modules, and then repeat for the next top x% CPU contributors until your performance goals are met.

A performance measurement and reporting tool, such as IBM Application Performance Analyzer (APA) for z/OS, can help determine the top CPU contributors. If performance measurements tools are not available then the RTI Profiler that comes with ABO can be used to help determine which COBOL modules are executed most when the application is running.

Characteristics of programs that benefit most from ABO

Some compiled programs will benefit more from ABO than others. Knowing some key characteristics of these programs can also help in staging use of ABO on your compiled COBOL programs.

ABO can only improve performance of the original compiler generated code and some select Language Environment (LE) routines, but ABO does not have the means to improve performance when time is spent in other subsystems such as CICS, Db2, and IMS.

Key characteristics of programs that might benefit more from optimization with ABO are:

- A significant portion of the application's execution time is spent in the COBOL code instead of in other subsystems such as CICS, Db2, and IMS.
 - The COBOL code is performing a significant amount of computations. For example, a program where the COBOL code itself is doing the actual, real work, and is not simply acting as a "driver" program for other programs or subsystems.
 - At the source level, some statements most likely to benefit include, but are not limited to: COMPUTE, IF, MOVE, ADD, SUBTRACT, MULTIPLY, DIVIDE, and REMAINDER.
 - In addition, some select Language Environment (LE) routines can also be optimized by ABO. These routines perform a variety of conversion, move, and arithmetic operations and include IGZCSH2, IGZCFPC, IGZCONV, IGZCVMO, IGZCXPR, IGZCXMU, and IGZCXDI. ABO optimizes these routines by more efficiently performing the work of these routines directly in the optimized code or by calling a more efficient LE routine.
- Note:** Looking at the COBOL source alone does not take into account where the time in the application is actually spent, so this should be done in combination with a performance report from an analysis tool such as APA.
- Most COBOL modules within the application are eligible for optimization by ABO. This means that the modules were compiled with an eligible COBOL compiler and contain language features that are supported by ABO.

Optimization and deployment usage scenarios

This section contains three typical usage scenarios for IBM Automatic Binary Optimizer for z/OS. These scenarios describe possible approaches to using the IBM Automatic Binary Optimizer for z/OS to improve

the performance of already compiled IBM COBOL programs. Each scenario provides step-by-step instructions to enable you to optimize your compiled IBM COBOL programs.

Scenario 1: Optimization process with static deployment

In this usage scenario, specify input modules to the optimizer in your JCL using BOPT directives, and for deployment, update all existing JCL that identifies data sets containing the original modules.

Procedure

To perform the optimization with static deployment, complete the following steps:

1. Create new data sets. For example, the following data sets are created for this scenario where *HLQ* is the high-level qualifier that you define.
 - *HLQ.OUTPUT.LOAD.ZEC12*. This data set will be populated with optimized binaries targeting the zEC12 machine.
 - *HLQ.OUTPUT.LOAD.Z13*. This data set will be populated with optimized binaries targeting the z13 machine.
 - *HLQ.OUTPUT.LOAD.Z14*. This data set will be populated with optimized binaries targeting the z14 machine.
2. Run ABO to populate the new data sets. To run the optimizer, create new JCL. In the in-stream line that starts with SYSIN, use the BOPT optimizer directive. Select your compiled COBOL programs to optimize with the IN option. For example, the following JCL instructs the optimizer to optimize all the members with names beginning with M from *HLQ.INPUT.LOAD*. The optimized binaries targeting zEC12, Z13 and z14 are placed in *HLQ.OUTPUT.LOAD.ZEC12*, *HLQ.OUTPUT.LOAD.Z13*, and *HLQ.OUTPUT.LOAD.Z14* respectively.

```
...  
//SYSIN DD *  
BOPT IN=HLQ.INPUT.LOAD(M*) OUT=HLQ.OUTPUT.LOAD.ZEC12 LIST=HLQ.OUTPUT.LIST.ZEC12 ARCH=10  
BOPT IN=HLQ.INPUT.LOAD(M*) OUT=HLQ.OUTPUT.LOAD.Z13 LIST=HLQ.OUTPUT.LIST.Z13 ARCH=11  
BOPT IN=HLQ.INPUT.LOAD(M*) OUT=HLQ.OUTPUT.LOAD.Z14 LIST=HLQ.OUTPUT.LIST.Z14 ARCH=12
```

The example is intended to reflect what the user should specify in the SYSIN file. For basic JCL configuration, see [Appendix A, “JCL sample,”](#) on page 63. For more sample JCL that you can use in the static deployment scenario, see [“Specifying optimization with BOPT”](#) on page 28.

3. To run the optimized programs, modify the JCL that is used to run the original programs. That JCL identifies data sets that contain the original modules. In the STEPLIB setting, you must place the data sets of the optimized modules ahead of the data sets of the original modules for each targeted architecture. The following snippets show the modified parts in JCL that points to the optimized and original program binaries.

Here's the modified part in the JCL that is used to run the original program on zEC12:

```
...  
//STEPLIB DD DSN=HLQ.OUTPUT.LOAD.ZEC12,DISP=SHR  
// DD DSN=HLQ.INPUT.LOAD,DISP=SHR  
...
```

Here's the modified part in the JCL that is used to run the original program on z13:

```
...  
//STEPLIB DD DSN=HLQ.OUTPUT.LOAD.Z13,DISP=SHR  
// DD DSN=HLQ.INPUT.LOAD,DISP=SHR  
...
```

Here's the modified part in the JCL that is used to run the original program on z14:

```
...  
//STEPLIB DD DSN=HLQ.OUTPUT.LOAD.Z14,DISP=SHR  
// DD DSN=HLQ.INPUT.LOAD,DISP=SHR  
...
```

Scenario 2: Optimization process with dynamic deployment

In this usage scenario, map input to output modules in IEFOPZxx SYS1.PARMLIB's members and then use the IEFOPZ optimizer directive to specify optimization of input to output modules. After the binary optimization completes, run the optimized programs with no changes to the existing JCL that was used to run the original programs.

About this task

IEFOPZxx contains statements that define the data set optimization configuration which provide a list of pairings of an old COBOL library and the intended new libraries (one for each desired architecture level) and specifies which members are to be processed (optimized). For more information, see *z/OS MVS Initialization and Tuning Reference*.

Procedure

To perform the binary optimization with dynamic deployment, complete the following steps:

1. Create new data sets. For example, the following data sets are created for this scenario where *HLQ* is the high-level qualifier that you define.
 - *HLQ.OUT.LOAD.ZEC12*. This data set will be populated with optimized binaries targeting the zEC12 machine.
 - *HLQ.OUT.LOAD.Z13*. This data set will be populated with optimized binaries targeting the z13 machine.
 - *HLQ.OUT.LOAD.Z14*. This data set will be populated with optimized binaries targeting the z14 machine.
2. Define the IEFOPZ configuration.
 - a. Create an IEFOPZxx member.
 - b. For each old data set that contains the compiled module that you want to optimize, define an OLD/NEW pair in the IEFOPZxx member. Mark the OLD/NEW pair as INACTIVE so that the system does not do any OLDNEW processing unexpectedly. See the following example:

```
MAXARCH(12)
CHECKALL
OWNER(IBM) MINARCH(10)
OLDNEW(
  OWNER(IBM)
  OLD (DSN(HLQ.IN.LOAD))
  NEW (DSN(HLQ.OUT.LOAD.ZEC12) ARCH(10))
  NEW (DSN(HLQ.OUT.LOAD.Z13)   ARCH(11))
  NEW (DSN(HLQ.OUT.LOAD.Z14)   ARCH(12))
  INCLUEMEMBERS(M*) //Identifies to process all members beginning with M
  INACTIVE
)
```

Note: The OLD/NEW pairs can be defined in one or multiple IEFOPZxx members.

3. To activate the IEFOPZ configuration, use the following z/OS MVS System command:

```
SET IEFOPZ=( $x_1, \dots, x_n$ )
```

where x_1, \dots, x_n are the suffixes xx for the IEFOPZxx members. If in the previous step, you only create one member, the command is as follows:

```
SET IEFOPZ= $x_1$ 
```

Note: The SET command modification stays through the current IPL session only. Therefore, it is usually used for the new configuration quick test, or to override some permanent definitions during the current IPL session. For permanent configuration definitions, see step 5.

4. Run IBM Automatic Binary Optimizer for z/OS to populate the new data sets.

To run the optimizer, write JCL as follows. In the in-stream data that starts with SYSIN, use the IEFOPZ directive.

```

//SYSIN DD *
IEFOPZ SEL_ARCH=10 LIST=HLQ.B0ZOPT.ARCH10.LIST
IEFOPZ SEL_ARCH=11 LIST=HLQ.B0ZOPT.ARCH11.LIST
IEFOPZ SEL_ARCH=12 LIST=HLQ.B0ZOPT.ARCH12.LIST

```

The example is intended to reflect what the user should specify in the SYSIN file. For basic JCL configuration, see Appendix A, “JCL sample,” on page 63. For more sample JCL that you can use in the dynamic deployment scenario, see “Specifying optimization with IEFOPZ” on page 31.

5. Update your IEASYSxx SYS1.PARMLIB member with the IEFOPZ system parameter so that subsequent IPLs will properly activate the desired IEFOPZ configuration. For example, to have the IEFOPZ configuration specified in member IEFOPZ99 automatically activated with each subsequent IPL, put the IEFOPZ=99 statement into your IEASYSxx member. However, the SET command described in step 3, if issued for example as follows: SET IEFOPZ=99, will activate the desired IEFOPZ99 member for the current IPL session only.
6. Redefine the OLD/NEW pairs as ACTIVE. If you want OLD/NEW processing to be done for any DDNAMEs other than JOBLIB and STEPLIB, define those within an IEFOPZxx parmlib member using the DDNAME statement. Then activate that updated IEFOPZ configuration.
7. Run the optimized programs by using the existing JCL that was used to run the original programs.

Related reference

[“Related publications” on page 85](#)

Scenario 3: Optimization process using a hybrid approach

In the hybrid approach, specify the input binaries to optimize explicitly in your JCL as what you do in Scenario 1, but combine with dynamic deployment demonstrated in Scenario 2. With dynamic deployment, run the optimized modules without changing the existing JCL.

Procedure

To perform the binary optimization using a hybrid approach, complete the following steps:

1. Create new data sets. For example, the following data sets are created for this scenario where *HLQ* is the high-level qualifier that you define.
 - *HLQ.OUT.LOAD.ZEC12*. This data set will be populated with optimized binaries targeting the zEC12 machine.
 - *HLQ.OUT.LOAD.Z13*. This data set will be populated with optimized binaries targeting the z13 machine.
 - *HLQ.OUT.LOAD.Z14*. This data set will be populated with optimized binaries targeting the z14 machine.
2. Run IBM Automatic Binary Optimizer for z/OS to populate the new data sets.

To run the optimizer, create new JCL. In the in-stream data that starts with SYSIN, use the BOPT optimizer directive to select compiled COBOL modules to optimize. For example, the following JCL instructs the optimizer to optimize all the members that begin with the letter M from *HLQ.IN.LOAD*. The optimized binaries targeting zEC12, Z13, and z14 are placed in *HLQ.OUT.LOAD.ZEC12*, *HLQ.OUT.LOAD.Z13*, and *HLQ.OUT.LOAD.Z14* respectively.

```

//SYSIN DD *
BOPT IN=HLQ.IN.LOAD(M*) OUT=HLQ.OUT.LOAD.ZEC12 ARCH=10
BOPT IN=HLQ.IN.LOAD(M*) OUT=HLQ.OUT.LOAD.Z13 ARCH=11
BOPT IN=HLQ.IN.LOAD(M*) OUT=HLQ.OUT.LOAD.Z14 ARCH=12

```

The example is intended to reflect what the user should specify in the SYSIN file. For basic JCL configuration, see Appendix A, “JCL sample,” on page 63. For more sample JCL that you can use in the hybrid scenario, see “Specifying optimization with BOPT” on page 28.

3. Define the IEFOPZ configuration.
 - a. Create an IEFOPZxx member.

- b. For each old data set that contains the compiled module that you want to optimize, define an OLD/NEW pair in the IEFOPZxx member. Mark the OLD/NEW pair as ACTIVE. See the following example.

```
OLDNEW (
  OLD( DSNAME (HLQ.IN.LOAD) )
  NEW( DSNAME (HLQ.OUT.LOAD.ZEC12) ARCH(10) )
  NEW( DSNAME (HLQ.OUT.LOAD.Z13) ARCH(11) )
  NEW( DSNAME (HLQ.OUT.LOAD.Z14) ARCH(12) )
  INCLUDEMEMBERS(M*) //Identifies to process all members beginning with M
  ACTIVE )
```

Note: The OLD/NEW pairs can be defined in one or multiple IEFOPZxx members.

- c. If you want OLDNEW processing to be done for any DDNAMEs other than JOBLIB and STEPLIB, define those within an IEFOPZxx parmlib member using the DDNAME statement. Then activate that updated IEFOPZ configuration by using the following command:

```
SET IEFOPZ=( $x_1, \dots, x_n$ )
```

where x_1, \dots, x_n are the suffixes xx for the IEFOPZxx members. If in the preceding step, you create only a single member, the command is as follows:

```
SET IEFOPZ= $x_1$ 
```

4. Run the optimized programs by using the existing JCL that was used to run the original programs.

Related reference

[“Related publications” on page 85](#)

Testing information

The optimized modules that ABO produces will run faster but will have the same behavior, except from some isolated error message and abend code differences, as the original COBOL modules. ABO is able to do this because it processes the binary code within the COBOL module so it is able to ensure the low level logic of the program remains the same. This means that users of ABO do not have to perform full functional verification testing of the ABO optimized modules. Some limited testing is recommended to ensure basic functioning of the applications using the ABO optimized modules prior to deploying ABO optimized modules into a production environment.

Performance testing is best done in a controlled environment with the same input data used with the original application and with the application containing ABO optimized modules. Using a machine or LPAR that has as few as possible other applications running for performance testing will allow for stable and reproducible performance results. Comparing the CPU time between the original application and optimized application is the best way to see performance gains.

Chapter 8. Resolving problems with optimization and optimized module deployment

Resolving problems that occur during optimization time

The return code that ABO passes to z/OS is an indicator of whether a problem was encountered during optimization. A return code value of zero means that optimization was successful and no problems were encountered. A return code value other than zero, indicates something unexpected occurred or a problem was encountered. For more information on return codes, see [Appendix B, “Return codes,”](#) on page 65.

ABO produces output files that can be used to diagnose problems.

The following files can be helpful in diagnosing problems encountered during the optimization of COBOL programs:

- The [log file](#) gives a summary of what has been optimized or scanned, and error messages if applicable. See [Messages](#) for more information. The log file is the first place you should examine if problems are detected during the optimization process.
- The file specified by the [OPTERR DD](#) are written to in exceptional circumstances. If the OPTERR DD is not specified, those messages are written to the JOBLOG.
- The file specified by the [CEEDUMP DD](#) are written to in circumstances such as a program exception when running ABO. The CEEDUMP file is produced by Language Environment (LE) and includes information such as a traceback of procedures that were executing at the time of the abend.
- The JOBLOG includes additional diagnostic messages that complement error messages that were written elsewhere or the JOBLOG can be a default location for errors encountered in exceptional circumstances.

Resolving problems encountered during execution

The problem determination tools provided by IBM in the [Application Delivery Foundation for z Systems](#) can be used to determine the source of execution time problems in applications that contain ABO optimized modules. If problem determination tools are not available the listing transform produced by ABO can be helpful in diagnosing execution time problems.

If diagnoses determines that an ABO optimized module that is causing the execution time problem then revert back to the original COBOL module and contact IBM service to report the problem.

Changes in COBOL module size after optimization

The size of an optimized module is typically larger than the original module due to the types of optimizations ABO does to improve performance.

Here are some common reasons for the module size increase:

- Use of higher ARCH instructions that are usually 6 bytes versus 4 or 2 bytes in length for many lower ARCH instructions. For example:
 - Using Decimal Floating Point (DFP) for packed/zoned decimal arithmetic to improve performance
 - Replacing "base locator" pointers in the original module with more efficient but larger long displacement instructions

- Using more than one move immediate instruction instead of one in memory move
- A number of optimizations in ABO generate more code but shorter path length and better performance. For example:
 - More efficient handling of numeric edited variables
 - Unrolling long move and compare operations instead of using shorter but much slower instructions
 - Conditionally correcting decimal precision for binary data
- The inlining of the behavior of various runtime library routines results in more code in the optimized module but much faster performance in many cases.

So for these and similar reasons the optimized modules produced by ABO are often larger than the original modules and require more on disk storage. However, the amount of memory used by the optimized program itself when running is the same as that used by the original module. A slightly higher EXCP count will sometimes be observed when running the optimized program but this is only due to the few extra I/O operations required to load the larger module.

Note that an optimized module will keep its size unchanged if the optimized code happens to be smaller than the original code.

Error message and abend code differences

The optimized modules generated by ABO are in almost every case functionally equivalent to the corresponding original modules. However, in some rare cases an ABO generated module will produce different Language Environment (LE) runtime messages or different CICS abend codes than the original module.

This can happen when division on large data items and other complex operations are inlined or optimized in the generated code by ABO for more efficient processing, instead of being handled by an LE library routine or inefficient machine instructions.

In a non-CICS application, an ABO generated module:

- may produce a fixed-point divide exception (CEE3209S) message in places where the original module produced a decimal-divide exception (CEE3211S) or IGZ0061S message.
- may produce a decimal-divide exception (CEE3211S) in places where the original module produced a IGZ0061S message

For reference the full LE runtime message text for these differing exceptions is given below.

```
CEE3211S The system detected a decimal-divide exception (System Completion Code=0CB).
IGZ0061S Division by zero occurred in program 'program-name' at displacement 'displacement'.
CEE3209S The system detected a fixed-point divide exception (System Completion Code=0C9).
```

For a CICS application the abend code returned by "CICS ASSIGN ABCODE" can change from '1061' from the original module to 'ASRA' from the ABO generated module.

Application Delivery Foundation for z Systems

You can use Application Delivery Foundation for z Systems (ADFz) on ABO generated modules.

Find out more about Application Delivery Foundation for z Systems at <https://www.ibm.com/ca-en/marketplace/app-delivery-foundation-on-zsystems>.

The following Application Delivery Foundation for z Systems family of problem determination tools can be used on ABO generated COBOL modules:

- Developer for z Systems Enterprise Edition, which includes the IBM Debug for z Systems (previously known as IBM Debug Tool (DT) for z/OS)

- Fault Analyzer for z/OS (FA)
- Application Performance Analyzer for z/OS (APA)

In order to use these tools more effectively, you need to produce a LANGX side file for each optimized program. DT, FA, and APA exploit the side file to provide a better tool experience. For example, source-level debugging is provided with Debug for z Systems when a LANGX side file is provided. Without the side file, source-level debugging is not possible.

Creating a LANGX side file

IPVLANGO is a new tool provided with IBM Problem Determination Tools Common Component for z/OS V1.7, which is shared by the Application Delivery Foundation for z/OS tools. IPVLANGO combines the SYSDEBUG data set or compiler listing or the LANGX side file of the original compiled program along with the ABO listing transform to produce a new LANGX side file appropriate for the ABO generated module. Use the new LANGX file when you use DT, FA, or APA on the ABO generated module.

Run Time Instrumentation Profiler

The IBM Run Time Instrumentation (RTI) Profiler is a performance analysis tool to collect and report on the execution time CPU performance characteristics of your batch z/OS applications.

Introduction

The RTI Profiler uses the Runtime Instrumentation Facility added in zEC12 to collect high fidelity information about a batch program's CPU performance characteristics at a low overhead.

The supported z/OS versions for using the RTI Profiler are:

- z/OS Version 2.3
- z/OS Version 2.2
- z/OS Version 2.1

All the Language Environment (LE) CSECTs in your application are profiled in order to get a complete picture of overall CPU performance. This includes programs compiled by the IBM COBOL, C/C++ and PL/I compilers as well as COBOL programs optimized by ABO. The time spent in any LE library routines is also collected and reported.

The output of the RTI Profiler is a text file containing details per compiled or optimized CSECT and offsets within this CSECT of where the program is spending its time while running.

In conjunction with the corresponding listing files for the programs being profiled, the RTI Profiler output can help determine specific parts of your program, down to the machine instruction, where there may be opportunities for improving application CPU performance.

Due to the detailed level of information produced, the primary intended use case for the RTI Profiler is to provide IBM support and development with data to aid in performance investigations. In this scenario, an IBM support or development representative requests the RTI Profiler be used, and its output sent to IBM along with other artifacts (e.g. listing files) from the original compilation or optimization of your programs.

If you require more complete and full featured application profiling then we recommend using a profiling tool such as [Application Performance Analyzer for z/OS in ADFz](#).

System requirements and restrictions

The RTI Profiler can only be used on zEC12/zBC12, z13/z13s, and z14 systems. This restriction is because the RTI Profiler uses the Runtime Instrumentation Facility that was only added starting with zEC12 systems.

The RTI Profiler will not work if your z/OS operating system is running on z/VM. If run on z/VM guest then the message RISTART: AUTH REQUEST FAILED is output to the job log.

The RTI Profiler can be used on all batch applications including IMS batch and batch programs that interact with Db2.

The RTI Profiler does not work for CICS applications and is not supported for any application that is part of a non-batch IMS environment.

Usage instructions

The RTI Profiler consists of the two members BOZBXITA and BOZRIDT included in the same dataset where ABO was installed.

- BOZBXITA: links CEEBXITA and the related profiling routines to the main program of the application. This step enables the starting and stopping of the profiling as well as the monitoring and managing of the buffers for the RTI Profiler during the program execution.
- BOZRIDT: processes the RTI Profiler buffer data and generates the text file report.

Before using the RTI Profiler, you must allocate a PDS or PDSE dataset in order to hold the profiling results. The RTI Profiler generated report is stored into a member of this dataset. In the following JCL examples, this dataset is named hlq.SYSPROFD.

The following table shows the recommended allocation parameters for hlq.SYSPROFD.

<i>Table 11. Recommended allocation parameters</i>	
Data sets	Recommended allocation parameters
hlq.SYSPROFD (as a PDS)	Space units : CYLINDER Primary quantity : 10 Secondary quantity : 10 Directory blocks : 10 Record format : FB Record length : 80 Block size : 27920 Data set name type PDS
hlq.SYSPROFD (as a PDSE)	Space units : CYLINDER Primary quantity: 10 Secondary quantity : 10 Directory blocks : 10 Record format : FB Record length : 80 Block size : 27920 Data set name type LIBRARY

To use the RTI Profiler, follow these steps:

1. In the link-edit step, rebind your existing program to include BOZBXITA
2. In the execution step, specify the location of the dataset that will hold the profiling results

In the steps and JCL examples below hlqboz.BOZ130.SBOZMOD1 is the installation location chosen for ABO.

Step 1. Rebind your existing program to include BOZBXITA

The first step is to rebind your existing program to include BOZBXITA so the RTI Profiler is enabled when running your program.

To perform this rebind, modify the link-edit step of the program containing the main entry point to your application:

- Add hlqboz.BOZ130.SBOZMOD1 to the link-edit step as SYSLIB
- Include BOZBXITA as additional input to link-edit step

Below is a JCL example for this step:

```
//LKED EXEC PGM=IEWL,PARM='options'
//SYSLIB DD DISP=SHR,DSN=hlqboz.BOZ130.SBOZMOD1 <-- add hlqboz.BOZ130.SBOZMOD1 as SYSLIB
//      DD DSN=hlqcee.SCEELKED,DISP=SHR
//      DD DSN=hlqcee.SCEELKEX,DISP=SHR
//LOAD DD DISP=SHR,DSN=&LOAD
//SYSLMOD DD DISP=SHR,DSN=&SYSLMOD(pgmname)
//SYSPRINT DD SYSOUT=*
//SYSLIN DD *
INCLUDE LOAD(pgmname)
INCLUDE SYSLIB(BOZBXITA) <-- add INCLUDE for BOZBXITA
NAME pgmname(R)
```

Step 2. Specify the location of the dataset that will hold the profiling results

The second step is to specify the location of the dataset that will hold the profiling results generated by the RTI Profiler.

In your existing JCL for executing your program:

- Add hlqboz.BOZ130.SBOZMOD1 to the existing STEPLIB
- Add the DDNAME SYSPROFD to receive the profiling results

Below is JCL example for this step:

```
//GO EXEC PGM=pgmname,REGION=0M
//STEPLIB DD DSN=&SYSLMOD,DISP=SHR <-- &SYSLMOD is the output dataset from the rebind in step 1
//      DD DSN=hlqboz.BOZ130.SBOZMOD1,DISP=SHR <-- add hlqboz.BOZ130.SBOZMOD1 to STEPLIB
//SYSPROFD DD DSN=hlq.SYSPROFD(pgmname),DISP=SHR <-- add SYSPROFD DD
```

When program execution completes, the profiling results are contained in hlq.SYSPROFD(pgmname).

If SYSPROFD is not added in the execution step then the message RIDATA: OPENING SYSPROFD FAILED is generated to the job log. Also, the abend code ABEND=S000 U1130 REASON=00000000 is produced.

Notes:

1. For step 1, the same set of the link options as the original module must be used when rebinding for RTI Profiler usage. To verify the same set of the link options were used, you can use AMBLIST on the original and rebound modules. The most likely mismatch for COBOL programs is inadvertently changing AMODE from 24 to 31 when rebinding. Below is a JCL example that shows how to set the link options for AMODE=24.

```
//LKED EXEC PGM=IEWL,PARM='LIST,MAP,AMODE=24'
```

2. If the program to be profiled was compiled using VS COBOL II or an ABO optimized VS COBOL II compiled program, an extra step might be needed to rebind the module to replace the bootstrap routine IGZEBST with the current version from LE. If you do not see any profiling output at the SYSPROFD location after step 1 and you attempt to profile VS COBOL II or an ABO optimized VS COBOL II compiled program, follow the steps below to replace the IGZEBST routine and enable the module for RTI profiling.

```
//LKED EXEC PGM=IEWL,PARM='options' <- original link options
//SYSLIB DD DSN=hlqcee.SCEELKED,DISP=SHR
//      DD DSN=hlqcee.SCEELKEX,DISP=SHR
//LOAD DD DISP=SHR,DSN=&LOAD <- original module that will be linked with new IGZEBST
//SYSLMOD DD DISP=SHR,DSN=&SYSLMOD(pgmname) <- output module location
//SYSPRINT DD SYSOUT=*
//SYSLIN DD *
INCLUDE SYSLIB(IGZEBST) <- new bootstrap to include from CEE
INCLUDE LOAD(pgmname) <- original member from LOAD to link new parts into
REPLACE -IMMED,IGZEBST <- bootstrap member to replace
ENTRY pgmname
NAME pgmname(R)
//*
```

Appendix A. JCL sample

The following JCL sample is included in the IBM Automatic Binary Optimizer for z/OS installation package.

```
//BOZJCLE JOB <job parameters>
//*****
//* Job Name: BOZJCLE *
//* *
//* Licensed Materials - Property of IBM *
//* 5697-AB1 *
//* Copyright IBM Corp. 2017 *
//* *
//* US government users restricted rights *
//* use, duplication or disclosure restricted *
//* by GSA ADP schedule contract with IBM Corp. *
//* *
//*****
//OPT EXEC PGM=BOZOPT,REGION=0M
//STEPLIB DD DSN=hlqboz.B0Z130.SBOZMOD1,DISP=SHR
//OPTLOG DD DSN=hlq.BOZOUT.OPTLOG(&BOZJOBID),DISP=SHR
//OPTERR DD DSN=hlq.BOZOUT.OPTERR(&BOZJOBID),DISP=SHR
//CEEDUMP DD DSN=hlq.BOZOUT.CEEDUMP(&BOZJOBID),DISP=SHR
//SYSPRINT DD DSN=hlq.BOZOUT.LISTING,DISP=SHR
//SYSBIN DD DSN=input-load-library,DISP=SHR
//SYSBOUT DD DSN=output-load-library,DISP=SHR
//SYSIN DD *
ARCH=arch-number
BOPT IN=DD:SYSBIN(member-name) OUT=DD:SYSBOUT(member-name)
```

In the JCL example, hlqboz.B0Z130.SBOZMOD1 is the installation location chosen for the optimizer.

This example requires the following data sets to be allocated beforehand:

- hlq.BOZOUT.OPTLOG
- hlq.BOZOUT.OPTERR
- hlq.BOZOUT.LISTING
- hlq.BOZOUT.CEEDUMP

You can allocate these data sets with the recommended parameters in the following table:

<i>Table 12. Recommended allocation parameters</i>	
Data sets	Recommended allocation parameters
hlq.BOZOUT.OPTLOG hlq.BOZOUT.OPTERR hlq.BOZOUT.LISTING	Space units: CYLS Primary quantity: 50 Secondary quantity: 50 Directory blocks: 10 Record format: VB ¹ Record length: 512 Block size: 27998 Data set name type: Library
hlq.BOZOUT.CEEDUMP	Space units: CYLS Primary quantity: 10 Secondary quantity: 10 Directory blocks: 10 Record format: FB Record length: 133 Block size: 27930 Data set name type: Library

Table 12. Recommended allocation parameters (continued)

Data sets	Recommended allocation parameters
<p>Notes:</p> <ol style="list-style-type: none">1. hlq.BOZOUT.OPTLOG and hlq.BOZOUT.OPTERR must have a record format of VB to be opened successfully. For hlq.BOZOUT.LISTING a record format of FB is also allowed, though information will be truncated from the listing if the record length is too short. A record length of at least 133 is recommended to ensure no truncation occurs.	

&BOZJOBID is a unique identifier for this job chosen by the user. It is used as the member name in each of the hlq.BOZOUT.OPTLOG, hlq.BOZOUT.OPTERR, and hlq.BOZOUT.CEEDUMP data sets. &BOZJOBID must be a valid member name.

This JCL sample shows a definition of the SYSIN DD for optimizing a single module. For more examples, see [“JCL examples” on page 28](#) and [“Optimization and deployment usage scenarios ” on page 51](#). For descriptions of the ddnames used in the example, see [“Required DD statements” on page 15](#).

Appendix B. Return codes

IBM Automatic Binary Optimizer for z/OS emits messages to provide information, provide possible warnings, or to report errors. Each message has a "Message return code" that is documented in [Appendix C, "Messages,"](#) on page 67. On termination, ABO passes a return code value to z/OS that is the maximum of the "Message return code" values of all the messages that were emitted. If no messages were emitted, then a return code of 0 is returned to z/OS.

Return code (decimal)	Description
0	Successful completion of all processing. One or more informational messages may have been emitted.
4	Successful completion but an unusual condition was detected. One or more warning messages have been emitted.
12	An error was detected during the processing of a BOPT or IEFOPZ directive or global option. One or more messages have been emitted. <ul style="list-style-type: none">• If the error occurs during syntax processing of a line of input, the rest of the line is rejected and ABO proceeds to process the next line of input.• If the error occurs while processing a BOPT or IEFOPZ directive, ABO proceeds to process the next applicable module of the BOPT or IEFOPZ directive. If there are no further input modules to process for the BOPT or IEFOPZ directive, processing of the directive is terminated and ABO proceeds to the next line of input to process the next directive or terminates if there are no more lines of input.
16	An unrecoverable error was detected. One or more messages are emitted and ABO immediately terminates processing.

Appendix C. Messages

The messages described in this section are written to the OPTLOG DD. In some exceptional cases, it may not be possible to write to the OPTLOG DD in which case the message is written to the OPTERR DD otherwise to the JOBLG. Each message, listed below, has a "Message return code" that is used to determine the return code returned to z/OS as described in [Appendix B, "Return codes,"](#) on page 65.

Each ABO message in this section has the form BOZnnnnX where BOZ indicates that the message is an ABO message, nnnn is the message number, X is the severity indicator.

Severity indicators can be any of the following: I, W, E, S, or U.

I	Informational message (RC=0)
W	Warning message (RC=4)
E	Error message (RC=8)
S	Severe error message (RC=12)
U	Unrecoverable error message (RC=16)

BOZ1003U Program caught signal &1, exiting with return code 16.**Explanation:**

The optimizer was unable to continue because an unexpected condition was encountered during processing.

System action:

The optimizer immediately terminates execution and returns to the operating system with a return code of 16.

User response:

Unexpected problems could happen due to an earlier problem. Correct any problems reported in the log file and retry the optimization process. If the problem persists, consult IBM service for assistance.

Message return code

16

BOZ1031S An error occurred while attempting to open "&1".**Explanation:**

The optimizer was unable to open the file specified by &1.

System action:

If the open failure was associated with one of the required optimizer DDs, such as the SYSIN DD, the optimizer immediately terminates with a return code of 16. Otherwise, if the file is specified on a line in the SYSIN input file (in a global option or BOPT or IEFOPZ

directive), processing of the line is terminated and the optimizer proceeds to process the next line of the SYSIN input file.

User response:

Ensure that the file name is correct, and that the file has been allocated and with an appropriate record format and with an appropriate record length.

Message return code

16 when attempting to open a mandatory DD, otherwise 12.

BOZ1145U Insufficient memory in the compiler to continue compilation.**Explanation**

The optimizer was unable to continue due to memory being low.

System action:

The optimizer immediately terminates execution and returns to the operating system with a return code of 16.

User response:

Consider using the JCL MEMLIMIT or JCL REGION parameters to increase the memory used by the optimizer. For more information, see the [z/OS MVS Initialization and Tuning Reference](#) and the [z/OS MVS Initialization and Tuning Guide](#).

Message return code

16

BOZ1400S **Directive is missing "&1" specifier.****Explanation**

The optimizer encountered a BOPT or IEFOPZ directive that requires an &1 specifier, but the specifier was missing.

System action:

The optimizer discards the directive and proceeds to process the next line in the SYSIN input file.

User response:

Correct the directive by adding an appropriate &1 specifier.

Message return code

12

BOZ1401S **"&1" directive must be specified at start of line.****Explanation**

An option preceded the &1 directive on a line of the SYSIN input file, or the line is missing the &1 directive.

System action:

The optimizer discards the directive and proceeds to process the next line in the SYSIN input file.

User response:

Fix the line by specifying &1 directive at the start of the line.

Message return code

12

BOZ1402S **Invalid specifier in "&1".****Explanation**

The &1 option of BOPT or IEFOPZ directive contained an invalid specifier. For example, "H" is an invalid specifier in the option: "SCAN=H".

System action:

The optimizer discards the directive with the invalid specifier and proceeds to process the next line in the SYSIN input file.

User response:

Change the specifier in the option to one that is valid.

Message return code

12

BOZ1403S **Invalid option "&1".****Explanation**

While processing the SYSIN input file, &1 was encountered such that &1 is not an optimizer directive and &1 is not a valid option.

System action:

The optimizer discards the line with the invalid option and proceeds to process the next line in the SYSIN file.

User response:

Correct the line of SYSIN by using a properly spelled directive or option.

Message return code

12

BOZ1404S **"&1" can only be specified on "&2" directive.****Explanation**

The &1 option was specified on a directive but it was not the &2 directive. For example, SEL_ARCH cannot be specified on the BOPT directive as SEL_ARCH is only applicable to the IEFOPZ directive.

System action:

The optimizer discards the line with the invalid option and proceeds to process the next line in the SYSIN file.

User response:

Fix the line with &1, by specifying a proper option or proper directive.

Message return code

12

BOZ1405S **"&1" not allowed on "&2" directive.****Explanation**

The &2 directive contained an option, &1, that is not applicable to the &2 directive. For example, the "IN" option is not applicable and cannot be specified on the IEFOPZ directive.

System action:

The optimizer discards the line with the invalid option and proceeds to process the next line in the SYSIN file.

User response:

Fix the line by specifying a proper option that applies to the &2 directive.

Message return code

12

BOZ1406S **Wildcards not supported in member specifier of "&1".**

Explanation

A line of SYSIN was encountered with an "IN" option with a member specifier (&1) that included wildcards, and an "OUT" option that included a dataset member specifier. When wildcards are used in an "IN" option, the "OUT" option must not include a member specifier.

System action:

The optimizer discards the line with the invalid option and proceeds to process the next line in the SYSIN file.

User response:

Change the "IN" option to not specify wildcards or remove the member specifier from the "OUT" option.

Message return code

12

BOZ1407S Output specifier "&1" invalid when using wildcards on input.

Explanation

The optimizer detected a BOPT directive with a wildcard specifier on the "IN" option and the "OUT" option specified a USS path of &1. When member wildcards are used on the "IN" option, the "OUT" option must specify a dataset and not a USS path.

System action:

The optimizer discards the BOPT option with the invalid "OUT" option and proceeds to process the next line in the SYSIN file.

User response:

Change the "IN" option to not specify wildcards or change the "OUT" option to specify a dataset.

Message return code

12

BOZ1408S Module specifier "&1" is an existing directory.

Explanation

The optimizer detected an HFS directory, &1, specified as the module location on the "IN" or "OUT" option of the BOPT directive. In HFS, a module is an ordinary file and not a directory.

System action:

The optimizer discards the directive and proceeds to process the next line in the SYSIN file.

User response:

Change the path specifier on the "IN" or "OUT" option to be an ordinary file and not a directory.

Message return code

12

BOZ1409S Output specifier "&1" is not an existing PDS(E).

Explanation

The optimizer encountered either:

- &1 as a NEW dataset from an IEFOPZ configuration
- &1 as a DD name or dataset name on a file specifier in the SYSIN file where the file specifier included a member name
- &1 as a dataset specifier for the LOG option

but, the dataset associated with &1 did not exist or the dataset was a sequential dataset and not a PDS(E).

System action:

In the IEFOPZ case, the optimizer ignores the NEW dataset and continues on processing the IEFOPZ configuration. Otherwise, the optimizer discards the directive and proceeds to process the next line in the SYSIN file.

User response:

Change the dataset location to an existing PDS(E) or allocate the PDS(E) prior to running the optimizer.

Message return code

12

BOZ1410I Output module "&1" cannot be replaced as REPLACE=N is in effect.

Explanation

When the REPLACE=Y option is specified, the optimizer issues this informational message when it detects that the output module (&1) of the same name already exists.

System action:

The optimizer bypasses optimizing the input module and proceeds to process the next module or next directive.

User response:

No action is required by the user.

Message return code

0

BOZ1411S Error getting member list from dataset specifier "&1".

Explanation

The optimizer was processing either:

- a BOPT directive where a PDS(E) (&1) was specified on the "IN" option (that included member wildcards) and the PDS(E) had no members

- a IEFOPZ directive, and an OLD dataset (&1) in the IEFOPZ configuration was found to have no members

System action:

In the case of a BOPT directive, the optimizer discards the directive and proceeds to process the next line of the SYSIN file. In the case of the IEFOPZ directive, the optimizer ignores the OLD dataset and proceeds to process the rest of the IEFOPZ configuration.

User response:

Check that the proper dataset was specified on the BOPT directive or that the proper dataset was specified in the IEFOPZ configuration.

Message return code

12

BOZ1412S IEFOPZ is not available on this system.

Explanation

The optimizer was processing an IEFOPZ directive on a z/OS system that did not have the IEFOPZ feature

System action:

The optimizer discards the IEFOPZ directive and proceeds to process the next line in the SYSIN file.

User response:

The IEFOPZ facility is only available on z/OS V2R2 and above. If the optimizer is run on a z/OS system prior to V2R2, change SYSIN to not specify the IEFOPZ directive. If the optimizer is run on z/OS V2R2 or higher, have your system programmer install the appropriate PTFs required for the IEFOPZ feature.

Message return code

12

BOZ1413S Problem with IEFOPZQ system service (return code="&1", reason code="&2"): &3.

Explanation

The optimizer encountered a problem reading an IEFOPZ configuration while processing an IEFOPZ directive. &1 specifies the error return code and &2 specifies the error reason code of the IEFOPZQ system service that is used to read the configuration. &3 gives a short description of the reason code.

System action:

The optimizer discards the IEFOPZ directive and proceeds to process the next line in the SYSIN file.

User response:

Provide this error message to your system programmer to see if the error is valid. If there are no

issues with IEFOPZ usage, consult IBM service providing this optimizer message and any other IEFOPZ configuration information.

Message return code

12

BOZ1414S Input specifier "&1" is not an existing PDS(E).

Explanation

The optimizer encountered either:

- &1 as an OLD dataset from an IEFOPZ configuration
- &1 as a DD name or dataset name on a file specifier in the SYSIN file where the file specifier included a member name

but, the dataset associated with &1 did not exist or the dataset was a sequential dataset and not a PDS(E).

System action:

In the IEFOPZ case, the optimizer ignores the OLD dataset and continues on processing the IEFOPZ configuration. Otherwise, the optimizer discards the directive and proceeds to process the next line in the SYSIN file.

User response:

Change the dataset name to an existing PDS(E) or allocate the PDS(E).

Message return code

12

BOZ1415S No DD definition is supplied for "&1".

Explanation

The optimizer could not find a DD definition for a mandatory optimizer DD (&1), or no DD definition was specified for a DD (&1) used in the SYSIN file.

System action:

If the DD is for a mandatory DD of the optimizer, the optimizer immediately terminates with a return code of 16. Otherwise, the optimizer discards the line of the SYSIN file that included the DD definition and processes the next line of SYSIN.

User response:

Provide a DD definition for the DD in error.

Message return code

16, if &1 is a mandatory DD, otherwise 12

BOZ1416S A member name is not specified for PDS(E) specifier "&1".

Explanation

The optimizer encountered an "IN" or "OUT" option that specified a PDS(E) (&1) and requires a member name, but no member was included on the option.

System action:

The optimizer discards the directive with the invalid "IN" or "OUT" option and proceeds to process the next line in the SYSIN file.

User response:

Change the "IN" or "OUT" option to include a dataset member.

Message return code

12

BOZ1417S File "&1" does not exist.

Explanation

Input file &1 could not be located. Two common reasons this can happen are:

1. A member of an existing input module PDS(E) does not exist
2. An invalid HFS path was specified

System action:

The optimizer ignores processing the directive (or input module) that used the invalid file specification and proceeds to process the next input module or next directive

User response:

Correct the problem by specifying an existing dataset member or correct the path specification to point to an existing HFS file.

Message return code

12

BOZ1418S Invalid file specification "&1".

Explanation

The specification of the file &1 is incorrect. Examples of incorrect specifications include:

1. A member name is specified twice:
 - once, in the definition of a DD
 - second, in an optimizer option or directive that included the DD definition
2. A HFS path is specified, but a directory in the path is non-existent or the path is not accessible.
3. The length of a DD name or dataset name is too long.

System action:

The optimizer ignores processing the directive (or input module) that used the invalid file specification and proceeds to process the next input module or next directive

User response:

Specify a proper format for the file specification (&1).

Message return code

12

BOZ1419S Output of load module(s) to "&1" is not supported when input has program object format.

Explanation

An input module has a newer program object format but the optimized module (&1) is targeted to the older load module format. This happens when the input module is a member of a PDSE or a file in a HFS path, but the optimized module is targeted to a member of a PDS or is targeted to a sequential dataset.

System action:

The optimizer terminates processing the input module and proceeds to process the next input module or next directive.

User response:

Correct the output location (&1) of the optimized module to be a member of a PDSE or to a HFS path.

Message return code

12

BOZ1420S Path "&1" must be absolute and begin with a "/".

Explanation

The specification (&1) of an input or output file is to an HFS file, but a full path specification is not provided for &1. A full or absolute file specification must begin with a "/" character. This error can happen, for example, when the optimizer processes an HFS specification of an a input module, output module or listing transform.

System action:

The optimizer bypasses optimizing a module when an invalid path is specified and proceeds to process the next input module or next directive.

User response:

Correct the specification of the path (&1) to be absolute.

Message return code

12

BOZ1421S Binder API "&1" failed: return code=&2 reason code=&3.

Explanation

While processing a module using a binder API (&1), the binder API returned with an unexpected return code (&2) and reason code (&3).

System action:

In most cases, the optimizer discontinues processing the input module and proceeds to process the next input module or next directive. In some cases (for example, return code=4, reason code = 0x83000526), the binder is able to recover from the problem (in this case unexpected input) and the optimization of the input module proceeds.

User response

Examine binder documentation for information on the reason code. The reason code information can help determine the cause of the problem. For example, the reason code may indicate that the input file for optimization is not a proper load module or program object file. In this case, correct the JCL or SYSIN file to specify a proper input module. For information about binder API return codes and reason codes, see [z/OS MVS Program Management: Advanced Facilities](#).

This message is normally preceded by a BOZ4116 binder message that might provide additional information that helps in your response.

Message return code

12 when the optimizer discontinues processing, otherwise 4.

BOZ1422S **Module cannot be processed as it is not marked executable.**

Explanation

The optimizer encountered an input module that was not marked executable. The optimizer requires the module to be marked executable in order for the optimization process to succeed.

System action:

The optimizer discontinues processing the input module and proceeds to process the next input module or next directive.

User response:

If this problem is expected for the module, then either ignore the message or change the optimizer directives to exclude the module. Otherwise, if the problem is unexpected, correct the bind steps that produced the input module so that the module resulting from the bind is marked executable.

Message return code

12

BOZ1423S **Module cannot be processed as it was linked EDIT=NO or otherwise cannot be reprocessed.**

Explanation

The optimizer encountered an input module that cannot be edited. The most common case where this can happen is when the bind step used to produce the module included the EDIT=NO binder option. Modules that cannot be edited are missing important information required by the optimizer.

System action:

The optimizer discontinues processing the input module and proceeds to process the next input module or next directive.

User response:

If this problem is expected for the module, then either ignore the message or change the optimizer directives to exclude the module. Otherwise, if the problem is unexpected, remove the EDIT=NO option from the bind steps that produced the input module.

Message return code

12

BOZ1424S **Module cannot be appropriately processed as program is SIGNEd.**

Explanation

The optimizer encountered an input module that is marked SIGNEd.

System action:

The optimizer does not supported SIGNEd modules and discontinues processing the input module and proceeds to process the next input module or next directive.

User response:

If this problem is expected for the module, then either ignore the message or change the optimizer directives to exclude the module. Otherwise, if the problem is unexpected, correct the bind steps used to produce the module so that the module is not marked SIGNEd.

Message return code

12

BOZ1428U **Insufficient memory encountered during binder API "&1": return code=&2 reason code=&3. Terminating optimizer.**

Explanation

While processing a module using a binder API (&1), the binder was unable to proceed due to memory

being low. The binder produces the return code (&2) and reason code (&3) indicating the memory problem.

System action:

The optimizer immediately terminates execution and returns to the operating system with a return code of 16.

User response

Consider using the JCL MEMLIMIT or JCL REGION parameters to increase the memory used during the optimization process. For more information, see the [z/OS MVS Initialization and Tuning Reference](#) and the [z/OS MVS Initialization and Tuning Guide](#).

This message is normally preceded by a BOZ4116 binder message that might provide additional information that helps in your response.

Message return code

16

BOZ1429U "&1" I/O error encountered during binder API "&2": return code=&3 reason code=&4. Terminating optimizer.

Explanation

While processing a module using a binder API (&2), the binder detected an I/O error of type &1. The binder API provided the return code (&3) and reason code (&4).

System action:

The optimizer immediately terminates execution and returns to the operating system with a return code of 16.

User response

The type (&1) of I/O problem and the reason code (&4) can help direct the steps of how to diagnose and fix the problem. See binder documentation for an explanation of the reason code. Now, an example is a "WRITE" (&1) error of the optimized module because the output PDS(E) or file system is full. The binder API information (&2) or reason code (&4) can help confirm, or lead to, the cause of the "WRITE" problem. Note that increasing the size of the PDS(E) (or file system) could fix the "WRITE" problem. For information about binder API return codes and reason codes, see [z/OS MVS Program Management: Advanced Facilities](#).

This message is normally preceded by a BOZ4116 binder message that might provide additional information that helps in your response.

Message return code

16

BOZ1430U Unrecoverable "&1" error encountered during binder API "&2": return code=&3 reason code=&4. Terminating optimizer.

Explanation

While processing a module using a binder API (&2), the binder detected an error of type &1. The binder API provided the return code (&3) and reason code (&4).

System action:

The binder immediately terminates with a return code of 16.

User response

The type (&1) of problem and the reason code (&4) can help direct the steps of how to diagnose and fix the problem. If you are unable to diagnose the problem, consult IBM service for assistance. For information about binder API return codes and reason codes, see [z/OS MVS Program Management: Advanced Facilities](#).

This message is normally preceded by a BOZ4116 binder message that might provide additional information that helps in your response.

Message return code

16

BOZ1431S Input module with unsupported feature (&1) encountered during binder API "&2": return code=&3 reason code=&4. Module bypassed.

Explanation

While processing a module using a binder API (&2), the binder detected that the module cannot be optimized due to the module contained a feature &1 that is not supported. The binder API provided the return code (&3) and reason code (&4).

One example of an unsupported feature is when the input is an object module (as opposed to the input being a load module or program object). Another example of this problem, is when the input module is not fully bound and contains "UNRESOLVED" references.

System action:

User response

Since the input module cannot be supported, the choices are:

- ignore the message

- change optimizer input to avoid optimizing the module
- fix the problem. For example, in the case of a module with "UNRESOLVED" references, change the build steps used to produce the module so that the module is fully bound

For information about binder API return codes and reason codes, see [z/OS MVS Program Management: Advanced Facilities](#).

This message is normally preceded by a BOZ4116 binder message that might provide additional information that helps in your response.

Message return code

12

BOZ1432S **Output module size exceeded module format limitations and cannot be saved.**

Explanation

The optimizer attempted to write the optimized module but ran into output format restrictions. A load module, saved into a PDS member (or sequential dataset), has the most restrictive format. Far less common is encountering a format limitation with a program objects (written to PDSE or HFS path).

System action:

The optimizer terminates optimizing the input module and proceeds to process the next module or next directive.

User response:

If the output module is to be saved into a PDS member or sequential dataset, consider changing the output location to be a member of a PDSE. Otherwise, consider splitting the program into multiple modules.

Message return code

12

BOZ1436S **Invalid ARCH specification : &1**

Explanation

An invalid or unsupported architecture specification (&1) was detected in one of the following cases:

1. In an ARCH option or SEL_ARCH option when processing the SYSIN file
2. When processing a NEW dataset in an IEFOPZ configuration

System action:

If the invalid specification was detected on a line of the SYSIN file, the optimizer discards the line with the invalid option and proceeds to process the next line in

the SYSIN file. If the invalid specification was detected processing a NEW dataset of an IEFOPZ configuration, the optimizer ignores the NEW dataset and proceeds to process the remainder of the IEFOPZ configuration

User response:

Correct the SYSIN file or IEFOPZ configuration by specifying an ARCH level supported by the optimizer.

Message return code

12

BOZ1437S **No BOPT or IEFOPZ directive found**

Explanation

The optimizer can neither find a BOPT nor an IEFOPZ directive.

System action:

The optimizer terminates execution and returns to the operating system with a return code of 12.

User response:

Check that your JCL includes at least one BOPT or IEFOPZ directive.

Message return code

12

BOZ1438U **dynfree dyn failed: rc=&1 for DD &2**

Explanation

The optimizer detected an error attempting to free an internal input DD name (&2) that the optimizer was using as part of the optimization process.

System action:

The optimizer immediately terminates execution and returns to the operating system with a return code of 16.

User response:

This problem could have been caused by an earlier problem. Correct any problems reported in the log file and retry the optimization process. If the problem persists, consult IBM service for assistance.

Message return code

16

BOZ1439U **dynfree saveDyn failed: rc=&1 for DD &2**

Explanation

The optimizer detected an error (the dynfree service returned &1) attempting to free an internal output DD

name (&2) that the optimizer was using as part of the optimization process.

System action:

The optimizer immediately terminates execution and returns to the operating system with a return code of 16.

User response:

This problem could have been caused by an earlier problem. Correct any problems reported in the log file and retry the optimization process. If the problem persists, consult IBM service for assistance.

Message return code

16

BOZ1446U An I/O error occurred while writing &1

Explanation

The optimizer detected an I/O error when writing to &1, where &1 could be either 'the Listing transform' or 'the Log file'.

System action:

The optimizer immediately terminates execution and returns to the operating system with a return code of 16.

User response:

Check whether the PDS(E) or file systems is full and allocate a larger file for the PDS(E) or increase the size of the file system. Also check whether the dataset was allocated with a proper record format and record length.

Message return code

16

BOZ1447U An Unexpected I/O error occurred

Explanation

The optimizer detected an I/O error during execution.

System action:

The optimizer immediately terminates execution and returns to the operating system with a return code of 16.

User response:

Check the definitions of the output files (you should be able to exclude the output modules) to ensure a proper record length and record format is used and check whether the files are full.

Message return code

16

BOZ1449U Unhandled out of memory exception

Explanation

The optimizer was unable to continue due to memory being low.

System action:

The optimizer immediately terminates execution and returns to the operating system with a return code of 16.

User response:

Consider using the JCL MEMLIMIT or JCL REGION parameters to increase the memory used by the optimizer. For more information, see the [z/OS MVS Initialization and Tuning Reference](#) and the [z/OS MVS Initialization and Tuning Guide](#).

Message return code

16

BOZ1450U Assertion failure, check logs for traceback

Explanation

The optimizer was unable to continue as an unexpected condition was encountered during processing.

System action:

The optimizer immediately terminates execution and returns to the operating system with a return code of 16.

User response:

Unexpected problems could happen due to an earlier problem. Correct any problems reported in the log file and retry the optimization process. If the problem persists, consult IBM service for assistance.

Message return code

16

BOZ1451S dyncalloc(): failed for DSN &1 with DD &2, errcode &3, info code &4

Explanation

The optimizer encountered an error allocating an internal DD (&2) for dataset (&1). &3 is the error code returned by the MVS dynamic allocation functions. &4 is the information code returned by the MVS dynamic allocation functions.

System action:

The optimizer terminates optimizing the input module and proceeds to process the next module or next directive.

User response:

Check that the dataset (&2) exists and is accessible and check that your JCL does NOT include a definition for the same DD (&2). Also, unexpected problems could happen due to an earlier problem. Correct any problems reported in the log file and retry the optimization process. If the problem persists, consult IBM service for assistance.

Message return code

12

BOZ1452S **dynalloc(): failed for path &1 with DD &2, errcode &3, info code &4**

Explanation

&3 is the error code returned by the MVS dynamic allocation functions. &4 is the information code returned by the MVS dynamic allocation functions.

System action:

The optimizer terminates optimizing the input module and proceeds to process the next module or next directive.

User response:

Check that the path is accessible and can be written to and check that your JCL does NOT include a definition for the same DD (&2). Also, unexpected problems could happen due to an earlier problem. Correct any problems reported in the log file and retry the optimization process. If the problem persists, consult IBM service for assistance.

Message return code

12

BOZ1453U **dynalloc(): failed for DUMMY DD &1 errcode &2, info code &3**

Explanation

The optimizer encountered an error allocating a mandatory DUMMY DD (&1) that is required for the optimization process. &2 is the error code returned by the MVS dynamic allocation functions. &3 is the information code returned by the MVS dynamic allocation functions.

System action:

The optimizer immediately terminates execution and returns to the operating system with a return code of 16.

User response:

Check that your JCL does NOT include a definition for the same DD (&1). Also, unexpected problems could happen due to an earlier problem. Correct any problems reported in the log file and retry the

optimization process. If the problem persists, consult IBM service for assistance.

Message return code

16

BOZ1455W **Unsupported feature "&1" found**

Explanation

This message is issued in one of the following situations:

1. When ABO encounters a COBOL CSECT (i.e. compiled COBOL program) built by a compiler not eligible for use with ABO or the CSECT contains a COBOL language feature not supported by ABO.
2. When ABO encounters a CSECT that is too complex to safely optimize.

In the first situation, ABO detected a feature "&1" that it does not support in the CSECT being processed. See COBOL module requirements for the compilers eligible for use with ABO and the COBOL language features not supported by ABO.

In the second situation, ABO has determined that the CSECT is too complex to be safely optimized so it has been skipped. ABO will only optimize a CSECT if it can ensure the optimized program will execute with the same logic as the original compiled program. In cases where the CSECT is so complex that ABO cannot guarantee this, ABO stops the optimization process and skips this CSECT. Any other eligible CSECTs in the module will still be processed.

Note that this message is issued for informational purposes only and does not indicate a functional issue with ABO.

System action:

ABO bypasses optimization of the CSECT and proceeds to process the next CSECT.

User response:

If you see message BOZ1455 issued for a particular unsupported feature while optimizing a large number of your modules, you may open an RFE to indicate that the lack of this feature is inhibiting your ability to use ABO effectively.

Message return code

4

BOZ1456S **"&1" cannot be both optimizer input and optimizer output.**

Explanation

The optimizer does not allow a dataset or file to be used as input to the optimizer as well as output from the optimizer. For example, an optimized module

cannot be written to a PDS(E) if that PDS(E) is also a source of input modules. This message is emitted when &1 is used as both a location of input to the optimizer and a location of output from the optimizer.

System action:

The optimizer terminates optimizing the input module and proceeds to process the next module.

User response:

Correct your JCL or SYSIN file such that the output datasets are separate from input datasets.

Message return code

12

BOZ1457S Invalid filter expression "&1".

Explanation

The optimizer cannot process the *mem_expr* parameter of BOPT optimizer directive or the *expr* parameter of the CSECT optimizer option. The expression contains invalid syntax or wildcards and cannot be processed as written.

System action:

The optimizer terminates optimizing the current directive and proceeds to process the next directive.

User response:

Correct the expression. See the description of the *mem_expr* parameter of "BOPT" on page 16 and the *expr* parameter of the [CSECT optimizer option](#).

Message return code

12

BOZ1490W Warning: AMODE/RMODE conflicts encountered during binder API "&1": return code=&2 reason code=&3. Operation performed and processing continues.

Explanation

During the optimization process, the binder detected a conflict with the AMODE and RMODE settings. This problem was detected by the binder API (&1) for which the binder issued a return code (&2) and reason code (&3). You can use binder reason code documentation along with the reason code (&3) to determine the precise nature of the conflict. Normally, the conflict is already present in the input module and not introduced by the optimization process.

System action:

The binder issues this BOZ1490 warning message and continues with the optimization of the input module.

User response:

The warning message may be an indicator of a problem with the input module being optimized. Fixing the problem may require fixing the build steps used to produce the input module. For information about binder API return codes and reason codes, see [z/OS MVS Program Management: Advanced Facilities](#).

Message return code

4

BOZ1491W Warning: problems encountered adding aliases to directory during binder API "&1": return code=&2 reason code=&3. Module saved and processing continues.

Explanation

During the optimization process, the binder detected an issue adding aliases to a directory. This problem was detected by the binder API (&1) for which the binder issued a return code (&2) and reason code (&3). An alias cannot be added to a PDS(E) directory when the binder finds that there is a member of the PDS(E) directory with the same name as the name of the alias.

System action:

The binder issues this BOZ1491 warning message and continues with the optimization of the input module.

User response

To resolve this problem, it is important to understand why there is an existing member in the output PDS(E) with the same name as the name of the alias. For example:

- Do not specify an alias name on the member specifier of IN option of a BOPT directive. If an alias name was specified, delete this BOPT directive and delete the member from the target dataset.
- An incorrect member specifier on the OUT option of a BOPT directive could cause a conflict with the name of an alias. Ensure that the OUT option of a BOPT directive has the same member specifier as the member specifier supplied of the IN option.
- Merging aliases from more than one input datasets could cause conflicts with aliases and member names of the two datasets. It is recommended that a different output dataset be used for each input dataset. For information about binder API return codes and reason codes, see [z/OS MVS Program Management: Advanced Facilities](#).

Message return code

4

BOZ1492W Warning: input module "&1" with exported symbols is saved to different named module "&2".

Explanation

The optimizer detected an input module (&1) in a PDS(E) that included exported symbols and the optimized module was being written to a differently named member (&2) in an output PDS(E).

System action:

The binder issues this BOZ1492 warning message and continues with the optimization of the input module.

User response:

To fix the problem, change your JCL or SYSIN file such that the member name of the optimized module is the same as the member name of the input module. Failing to do so could result in runtime problems with locating the optimized module because of the change in the member name.

Message return code

4

BOZ1493S	Concatenated DD "&1" encountered and not is allowed for "&2".
-----------------	--

Explanation

The optimizer detected an input or output DD definition (&1) that was the concatenation of two or more datasets. &2 provides the context in which the DDs were used. For example, &2 may indicate that the DD was used as an input module location, or as an output module location, or as an output listing transform location.

System action:

The optimizer bypasses directives that include concatenated DD definitions and the optimizer proceeds to process the next directive.

User response:

Fix your JCL to not include a concatenated DD definition for input modules, output modules and for listing transforms.

Message return code

12

BOZ1494S	Module not processed as it is not fully bound.
-----------------	---

Explanation

During the optimization process, a module was encountered in input that is not fully bound and the ALLOW=NOUNRESEXE option was specified. The optimizer will not process the module that is not fully bound unless the ALLOW=UNRESEXE option is specified.

System action:

The optimizer terminates optimizing the input module and proceeds to process the next module or next directive.

User response:

If the intent is to optimize partially bound modules, remove the ALLOW=NOUNRESEXE option. If the intent is to only optimize fully bound modules, ignore the error, or correct your JCL or SYSIN file to only process fully bound modules.

Message return code

12

BOZ4089I	IEFOPZ: did not get ARCH=&1 match for dataset: '&2' which has ARCH=&3.
-----------------	---

Explanation

While processing an IEFOPZ optimizer directive, the optimizer emits this informational message whenever a NEW dataset (&2) is found in an IEFOPZ configuration that has an ARCH specification (&3) that does not match the SEL_ARCH selector (&1) that was specified on the IEFOPZ optimizer directive.

System action:

The optimizer bypasses the NEW dataset and processes the next NEW dataset in the configuration.

User response:

No action is required by the user.

Message return code

0

BOZ4091I	IEFOPZ: did not get STATE=&1 match for dataset: '&2' which has STATE=&3.
-----------------	---

Explanation

While processing an IEFOPZ optimizer directive, the optimizer emits this informational message whenever a NEW dataset (&2) is found in an IEFOPZ configuration that has a STATE specification (&3) that does not match the SEL_STATE selector (&1) that was specified on the IEFOPZ optimizer directive.

System action:

The optimizer bypasses the NEW dataset and processes the next NEW dataset in the configuration.

User response:

No action is required by the user.

Message return code

0

BOZ4092I	IEFOPZ: did not get DSN='&1' match for dataset '&2'.
-----------------	---

Explanation

While processing an IEFOPZ optimizer directive, the optimizer emits this informational message whenever an OLD dataset (&2) is found in an IEFOPZ configuration that does not match the SEL_OLD selector value (&1) that was specified on the IEFOPZ optimizer directive.

System action:

The optimizer bypasses the OLD dataset and processes the next OLD dataset in the configuration.

User response:

No action is required by the user.

Message return code

0

BOZ4097I **No members in dataset '&1' to process**

Explanation

This message is emitted when there are no members in the dataset to process.

System action:

The optimizer continues processing the next dataset.

User response:

No action is required by the user.

Message return code

0

BOZ4101W **No applicable COBOL code section found, return code 4**

Explanation

This message is emitted in the following cases:

1. When the optimizer encounters a load module but does not optimize any CSECTs within the load module (note: the message is not printed if the REPLACE=Y option is specified and an optimized module already exists)
2. After a BOPT directive that has member wildcards in the "IN" option, but no modules in the "IN" dataset were optimized
3. After an OLD dataset is processed and no modules in an OLD dataset were optimized
4. After an IEFOPZ directive is processed but no modules were optimized

System action:

The optimizer continues processing the next module of input.

User response:

No action is required by the user.

Message return code

4

BOZ4107I **INFO: IDRL record not added to CSECT &1 as load module format does not support three IDRLs. Processing continues.**

Explanation

The optimizer issues this informational message when an IDRL record (for the binary optimizer itself) could not be added to an optimized CSECT in a load module because that CSECT already has 2 IDRL records. Note: a maximum of 2 IDRLs per CSECT is a restriction of load modules in PDS (but is not a restriction for program objects in PDSE).

System action:

The optimizer continues its processing of the output load module.

User response:

No action is required by the user.

Message return code

0

BOZ4109I **INFO: Adding a third IDRL to load module CSECT "&1".**

Explanation

While processing a CSECT (&1) in a load module, the optimizer emits this informational message when the optimizer adds its language record as the third IDRL of the CSECT (&1). Note that an update to the binder is required so that the binder can properly add a third IDRL to a CSECT. If the binder update is not installed on your system, the optimizer will emit a subsequent warning message when attempting to save the optimized load module.

System action:

If the optimizer emits a warning message when saving the module, the language record may not have been added to the CSECT and the optimizer continues processing of the CSECT. Otherwise, processing of the CSECT was successfully performed.

User response:

If the optimizer emits a warning message when saving the module, you should contact your system programmer to install the binder update and perform the optimization process again. Otherwise, no action is required by the user. The required binder update for this message is under APAR OA50460. See ["Supported operating systems" on page 3](#) for more information.

Message return code

BOZ4110I **INFO: performing a second bind to handle private section "&1" in class "&2" referring to ENTRY "&3" at offset &4.**

Explanation

The optimizer emits this message when processing a CSECT that had a COBOL ENTRY statement (&3) and there was a reference to the ENTRY (&3) from a private section (&1) from within a class (&2, which is normally C_WSA) at an offset (&4). Note that an update to the binder is required so that the second bind works successfully. Without the binder update, the optimized program could experience problems.

System action:

If the binder update is available, processing completes successfully. But, if the binder update is not available, the second bind may appear to complete successfully, but, runtime errors may happen.

User response:

If the binder update is installed on your system, no action is required. Otherwise, have your system programmer install the binder update and perform the optimization process again. The required binder update for this message is under APAR OA50460. See ["Supported operating systems"](#) on page 3 for more information.

Message return code

0

BOZ4111I **INFO: performing update to private section "&1" in class "&2" referring to ENTRY "&3" at offset &4.**

Explanation

The optimizer emits this message when processing a CSECT that had a COBOL ENTRY statement (&3) and there was a reference to the ENTRY (&3) from a private section (&1) from within a class (&2) at an offset (&4). Note that an update to the binder is required so that the second bind works successfully. Without the binder update, the optimized program will emit an error message when processing the reference.

System action:

If the binder update is not available, the optimizer emits an error processing the reference. Otherwise, the binder processes the reference successfully.

User response:

If the optimizer emitted an error processing the reference, have your system programmer install the binder update and perform the optimization process

again. Otherwise, no action is required. The required binder update for this message is under APAR OA50460. See ["Supported operating systems"](#) on page 3 for more information.

Message return code

0

BOZ4113I **CSECT &1 was excluded by filter - skip**

Explanation

This message is emitted when a CSECT is excluded by the optimizer due to the expression in the CSECT optimizer option.

System action:

The optimizer continues processing the next CSECT.

User response:

No action is required by the user.

Message return code

0

BOZ4114I **INFO: processing module that is not fully bound with ALLOW=UNRESEXE option in effect.**

Explanation

When the ALLOW=UNRESEXE option is specified, the optimizer issues this informational message when it encounters a module in input that is not fully bound.

This message is not issued if the module is fully bound.

This message can be used to determine which partially bound modules were processed by the optimizer.

System action:

If the binder update is not available, the optimizer emits an error processing the reference. Otherwise, the binder processes the reference successfully.

User response:

The optimizer processes the partially bound module and outputs an optimized partially bound module.

Message return code

0

BOZ4116I **Binder message "&1"**

Explanation

The optimizer uses binder services and a service might fail which prevents a module from being optimized. In response to a binder service that fails, ABO produces a message such as BOZ1429 and terminates processing

in some manner. The BOZ1429 message might lack detailed information as to why the binder service failed. For example, the BOZ1429 message indicates that the binder found some problem with the input module but BOZ1429 does not include the precise input problem that the binder found. To provide more information about binder services that fail, the optimizer captures severe binder messages and includes the text of a binder message within &1 of the BOZ4116 informational message. This means that, when a binder service fails, ABO normally emits two messages:

1. The BOZ4116 message with &1 holding the text of a severe binder message. The BOZ4116 message is followed by
2. A summary message such as BOZ1429, indicating the general nature of binder failure.

System action:

See the "System action" section of the summary message to determine the actions of the optimizer.

User response:

See the "User response" section of the summary message to determine what to do. The BOZ4116 message might provide information that helps guide your response.

Message return code

0

BOZ4117I **Member "&1" was excluded by filter - skip**

Explanation

This message is emitted when a module is excluded by the optimizer due to the expression in the IN option of the BOPT directive.

System action:

The optimizer continues processing the next module.

User response:

No action is required by the user.

Message return code

0

BOZ4119S **Continuation indicated on SYSIN line &1. Unable to read SYSIN line &2.**

Explanation

Continuation was indicated on line &1 of SYSIN with the last non-blank character of line &1 being a continuation char (either '+' or '-'). While reading SYSIN, the optimizer was unable to read line &2.

System action:

The optimizer discards the line.

User response:

Either remove the continuation character at the end of line &1 of SYSIN, or add a new line &2 to the SYSIN that will continue line &1.

Message return code

12

BOZ4120S **Cannot have more than one IN= or OUT= specifier.**

Explanation

This message is emitted when more than one IN or OUT specifier is detected in a BOPT directive.

System action:

The optimizer continues processing the next BOPT directive.

User response:

Remove IN or OUT specifiers from the BOPT directive until there is no more than one of each per directive.

Message return code

12

BOZ4121S **Invalid log specification. '&1' is not a directory.**

Explanation

Only directories are valid specifiers for the LOG option. &1 is not a directory.

System action:

The LOG option is ignored.

User response:

Correct the LOG specification to a supported format, see the [LOG option](#) for supported specifications.

Message return code

12

Notices

This information was developed for products and services offered in the U.S.A. IBM may not offer the products, services, or features discussed in this document in other countries. Consult your local IBM representative for information on the products and services currently available in your area. Any reference to an IBM product, program, or service is not intended to state or imply that only that IBM product, program, or service may be used. Any functionally equivalent product, program, or service that does not infringe any IBM intellectual property right may be used instead. However, it is the user's responsibility to evaluate and verify the operation of any non-IBM product, program, or service.

IBM may have patents or pending patent applications covering subject matter described in this document. The furnishing of this document does not give you any license to these patents. You can send license inquiries, in writing, to:

IBM Corporation
J74/G4
555 Bailey Avenue
San Jose, CA 95141-1099
U.S.A.

For license inquiries regarding double-byte (DBCS) information, contact the IBM Intellectual Property Department in your country or send inquiries, in writing, to:

Intellectual Property Licensing
Legal and Intellectual Property Law
IBM Japan, Ltd.
3-2-12, Roppongi, Minato-ku, Tokyo 106-8711

The following paragraph does not apply to the United Kingdom or any other country where such provisions are inconsistent with local law:

INTERNATIONAL BUSINESS MACHINES CORPORATION PROVIDES
THIS PUBLICATION "AS IS" WITHOUT WARRANTY OF ANY KIND,
EITHER EXPRESS OR IMPLIED, INCLUDING, BUT NOT LIMITED TO,
THE IMPLIED WARRANTIES OF NON-INFRINGEMENT,
MERCHANTABILITY OR FITNESS FOR A PARTICULAR PURPOSE.

Some states do not allow disclaimer of express or implied warranties in certain transactions, therefore, this statement may not apply to you.

This information could include technical inaccuracies or typographical errors.

Changes are periodically made to the information herein; these changes will be incorporated in new editions of the publication. IBM may make improvements and/or changes in the product(s) and/or the program(s) described in this publication at any time without notice.

Any references in this publication to non-IBM Web sites are provided for convenience only and do not in any manner serve as an endorsement of those Web sites. The materials at those Web sites are not part of the materials for this IBM product and use of those Web sites is at your own risk.

Trademarks

IBM, the IBM logo, and ibm.com are trademarks or registered trademarks of International Business Machines Corp., registered in many jurisdictions worldwide. Other product and service names might be trademarks of IBM or other companies. A current list of IBM trademarks is available on the Web at [“Copyright and trademark information”](#).

List of resources

IBM Automatic Binary Optimizer for z/OS publications

You can find the latest and most complete information about the IBM Automatic Optimizer for z/OS APARs and PTFs on the [fix list page](#).

You can find the following publications in the [IBM Automatic Binary Optimizer for z/OS library](#):

- *User's Guide*, SC27-8545-04
- *Program Directory*, GI13-4513-03

Related publications

z/OS publications

You can find the following publications in the [z/OS Internet Library](#).

- *Initialization and Tuning Reference*, SA23-1380, contains information about the parmlib member IEFOPZxx.
- *Program Management: Advanced Facilities*, SA23-1392, contains information on binder API return codes and reason codes.
- *System Management Facilities (SMF)*, SA38-0667, contains information about the SMF record 90 subtype 38, which captures the IEFOPZ configuration.
- *System Messages, Volume 8*, SA38-0675, contains information about the messages.

Enterprise COBOL for z/OS publications

You can find the following publications in the [Enterprise COBOL for z/OS library](#).

- *Customization Guide*, SC27-8712, contains information that helps you plan for and customize Enterprise COBOL under z/OS.
- *Language Reference*, SC27-8713, contains information about COBOL language and references needed to write a program for an IBM COBOL compiler.
- *Programming Guide*, SC27-8714, contains information and examples that help you write, compile, and debug programs and classes.
- *Migration Guide*, GC27-8715, contains information that helps you move to the latest version of IBM Enterprise COBOL.
- *Performance Tuning Guide*, SC27-9202, identifies key performance benefits and tuning considerations when using IBM Enterprise COBOL for z/OS.
- *Messages and Codes*, SC27-4648, helps you understand compiler and preprocessor messages.

Application Delivery Foundation for z Systems publications

You can find the following publication in the [IBM Knowledge Center](#).

- *IBM Application Performance Analyzer for z/OS User's Guide*, SC27-8403, contains information that helps identify system constraints and improve application performance.
- *IBM Developer for z Systems documentation* (online version only), contains information about the Integrated Development Environment (IDE), designed to increase developer productivity.
- *IBM Fault Analyzer for z/OS User's Guide and Reference*, SC19-4116, contains information about analyzing and fixing application and system failures.



Product Number: 5697-AB1

SC27-8545-04

