



@server®



Quick start guide for i5 520 (9405-520 or 9406-520)

1

Before you begin

This Quick start guide contains an abbreviated set of setup instructions designed to help you quickly unpack and set up a standard system. Users unfamiliar with this IBM® hardware should use the fully detailed, setup instructions that you can find in the IBM Systems Hardware Information Center. For details about how to access the information center, see task 11 *Finish your system setup*.



The exclamation mark surrounded by a gray triangle denotes caution. A CAUTION notice indicates the presence of a hazard that has the potential of causing moderate or minor personal injury. Before doing a step that contains a caution icon, read and understand the caution statement that accompanies it.



Rack-mounted devices are not to be used as a shelf or workspace. Do not place any object on top of rack-mounted devices.



Use safe practices when lifting.



CAUTION: The weight of this part or unit is between 32 and 55 kg (70.5 and 121.2 lb). It takes three persons to safely lift this part or unit. (C010)

Tools needed (Rack installation only)

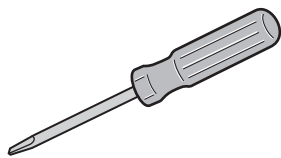

Flat-blade screwdriver

2

Inventory

2.1

Complete an inventory of the external parts.

Locate the kitting report (inventory list) in the bag that contains the information center CD (SK3T-8159). Make sure you received all of the parts that you ordered. Your order information should be located in an envelope adhered to the outside of your system box. You can also obtain order information from your marketing representative or IBM Business Partner.

If you have incorrect, missing, or damaged parts, contact any of the following resources:

- Your IBM reseller
- IBM Rochester manufacturing automated information line at 1-800-300-8751 (United States only)
- Directory of worldwide contacts at www.ibm.com/planetwide. Select your location to view the service and support contact information.

2.2

If you are not installing your server into a rack, skip to task 7 *Cable the server and Operations Console (LAN)*.

If you are installing your server into a rack, you will need the following parts:



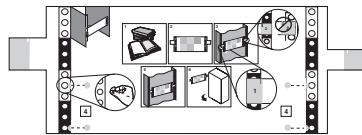

Rack-mounting template

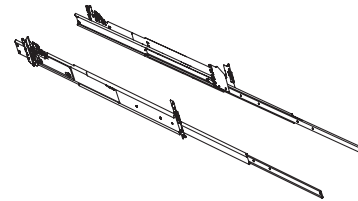

Slide rail assemblies



Rack-mounting hardware kit

	4	Blue knobs
	6	System-to-slide-rail screws
	4	Rack-retaining screws
	2	Blue thumbscrews
	2	Latch brackets
	2	Latch-bracket screws

Cable-management arm

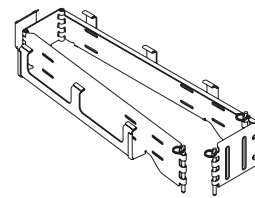

3

Prepare the rack for installation

3.1

If you are installing your server into a new rack, ensure that you have completed the unpacking instructions that were provided with the rack.

If your server is already installed in a rack, skip to task 7 *Cable the server and Operations Console (LAN)*.

3.2

Place the rack in the location of the installation.

3.3

Use the wrench that was provided with your rack to level the rack by raising or lowering the front and back leveling feet **A**.

3.4

Install the stabilizer bracket **B** on the front of the rack.

Tip: If necessary, remove any trim kit pieces that were previously installed on the rack. Removing the trim kit pieces allows you to read the EIA units on the rack.

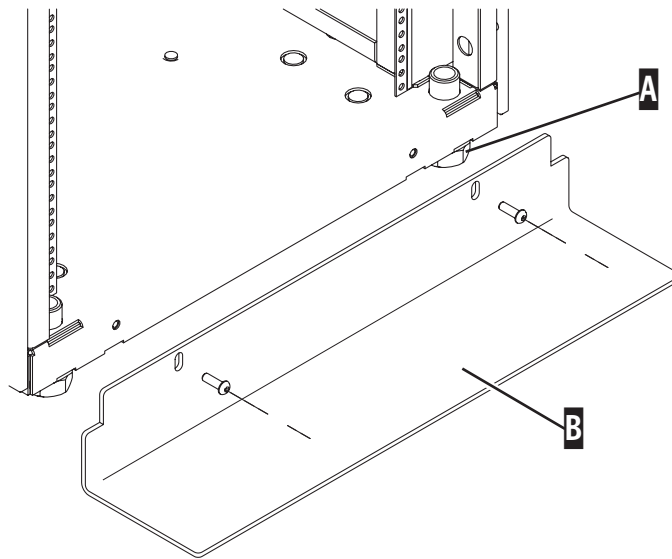

4

Install the slide rail assemblies

If you do not have enough space around your rack to open the front and back doors completely, remove the doors before starting this task to allow adequate access.

4.1

Locate the rack-mounting template, the rack-mounting hardware kit, and the slide rail assemblies that were included with your server.

4.2

Use the rack-mounting template to determine where in the rack to place the server. Remove any filler panels necessary to allow adequate access to the location where you will install your server.

Note: Install units into the lower part of the rack first. Place larger and heavier units in the lower part of the rack.

4.3

Follow the rack-mounting template to mark the location on the rack where you will place the server. Use the self-adhesive placement dots found on the rack-mounting template.

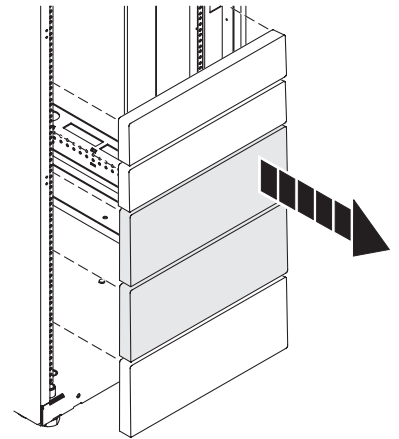

4.4

Install the slide rail assemblies **A**.

1. Pull the back latch-assembly release tabs **C** to the retracted position and lock the latch assembly **B**. Make sure the alignment pins **D** that are located on the back of the slide rail are fully retracted.
2. From the back of the rack, insert the front alignment pin **D** into the hole in the front of the rack, as identified by the self-adhesive placement dot.

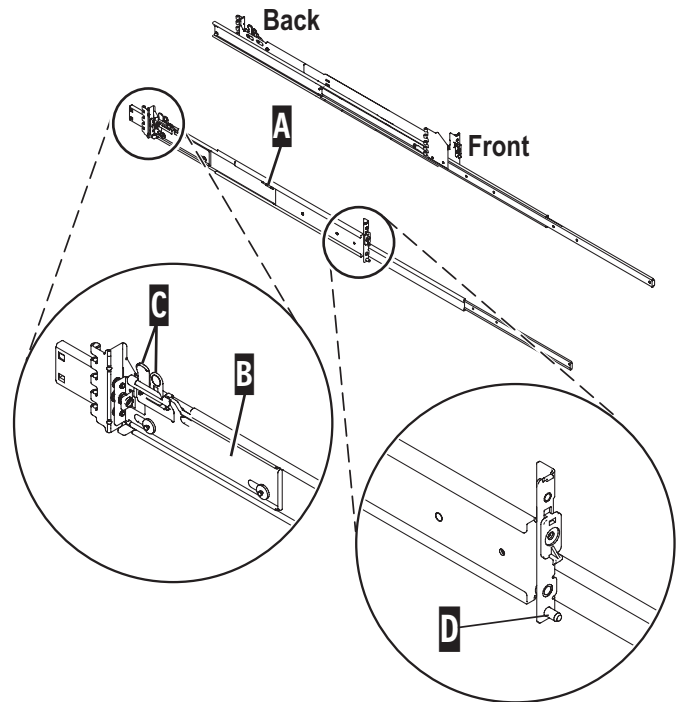

3. Align the retracted back pins **E** with the holes identified by the self-adhesive placement dots. Place the rack flange **F** between the slide-rail flange **G** and the retracted alignment pins **E**.
4. Press the back latch-assembly-release tab **C** to extend the back alignment pins into the back of the rack.

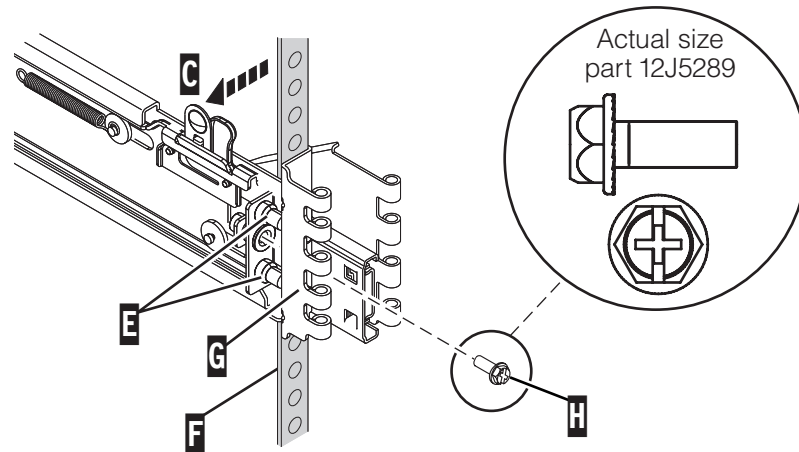

4.5

From the back, finger-tighten one of the rack-retaining screws **H** in the hole that is located between the two back alignment pins **E**.

4.6

From the front, finger-tighten one of the rack-retaining screws **I** in the first hole above the front alignment pin **J**.

4.7

From the front, attach the latch bracket **K** by inserting the hook into the rack hole above the hole **L** where you will place the latch bracket screw. Finger-tighten the screw.

4.8

Repeat steps 4.4 through 4.7 for each slide rail assembly.

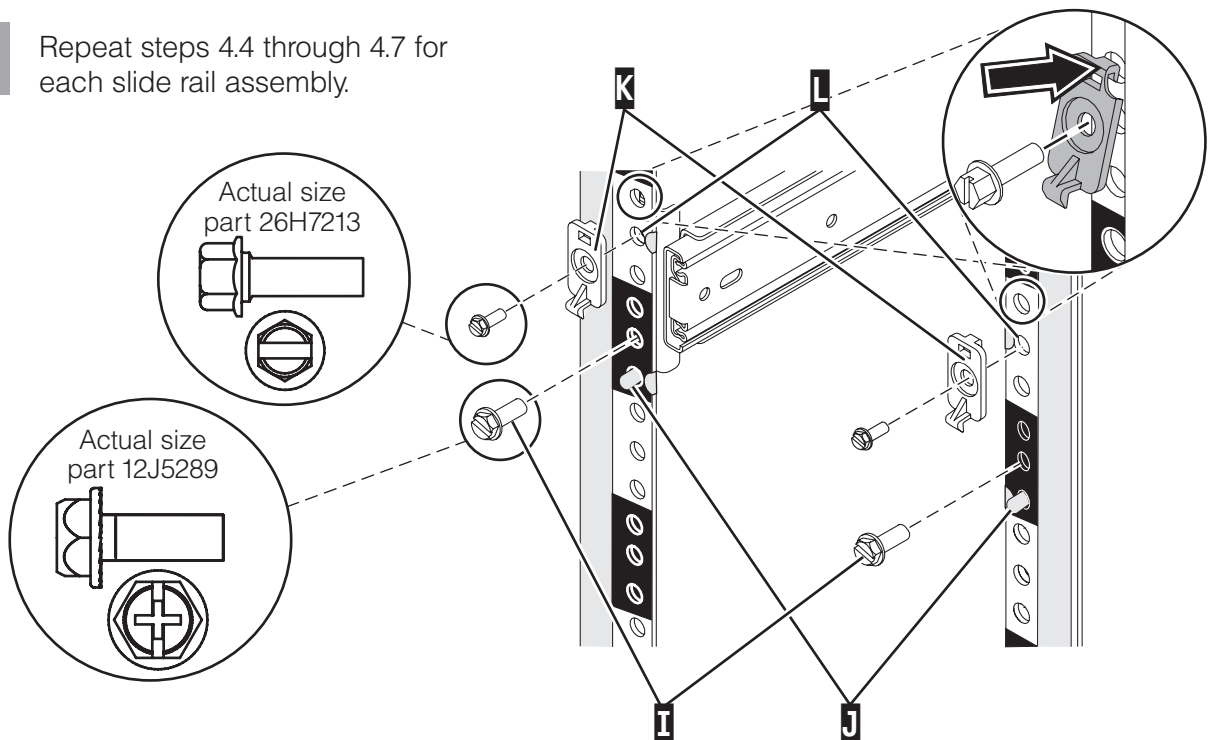

5

Install the server onto the slide rail assembly



Before installing the server onto the slide rail assembly, ensure that the leveling feet are extended and that the stabilizer bracket is correctly installed to prevent the rack from falling forward.

Before you begin: Read this entire task before completing any individual steps.

5.1

Attach the four blue knobs **B** to the server **A**. The blue knobs are used temporarily to rest the server on the slide rails for installation. These knobs will be removed after the server is secured to the slide rails.

5.2

Fully extend both slide rails.



Use safe practices when lifting.



5.3

Lift the server using the handles **C** on each side, and position the server on the extended slide rails. Align the three holes of the inner slide of the slide rails **D** with the three holes on each side of the server.

5.4

Using a screwdriver, attach the inner slide of the slide rails **D** to each side of the server by using the system-to-slide-rail screws **E**. Use a screwdriver to tighten each of the screws.

5.5

Remove the four blue knobs **B**.

5.6

Simultaneously release the blue safety latches **F** located near the front of each slide rail assembly, and slowly push the server back into the rack.

Tip: Pull the server back out and push it in again to make sure that the rails are aligned correctly and that it glides smoothly.

5.7

Using a screwdriver, tighten the two rack-retaining screws to secure the slide rails to the back of the rack.

5.8

Slide the server part of the way out of the rack. Using a screwdriver, tighten the front two rack-retaining screws and the two latch-bracket screws on the front of the rack to secure the slide rails.

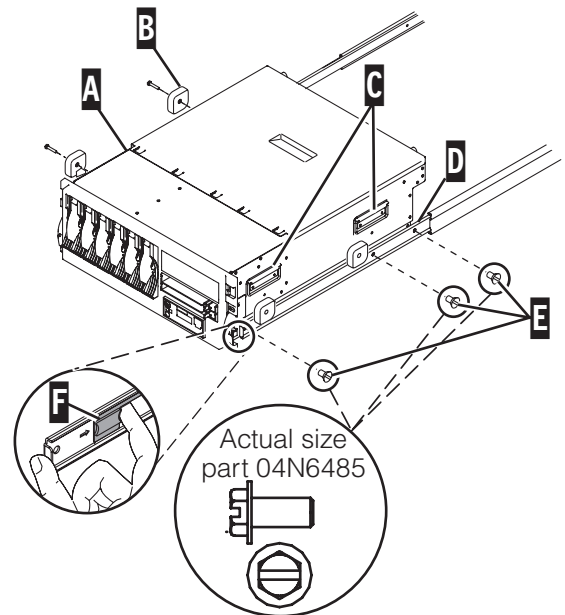

6

Install the cable-management arm

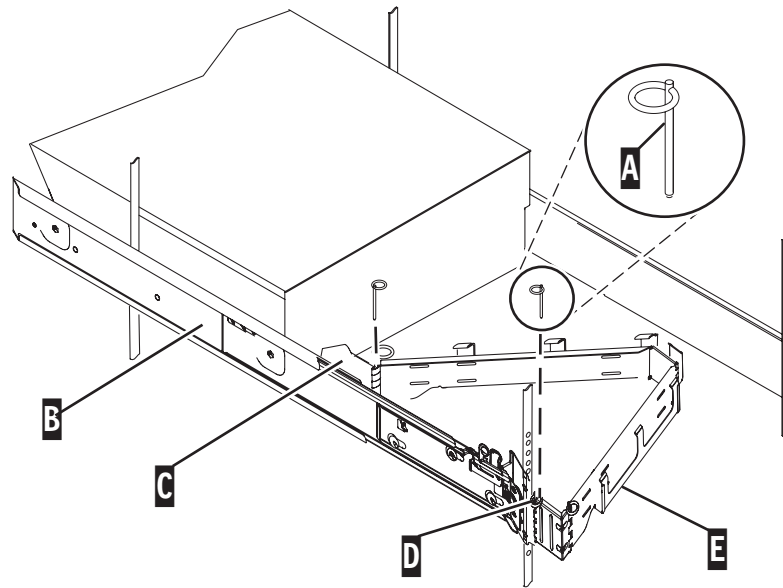

6.1

Locate the cable-management arm **E** and the two pins **A**.

Tip: If space is limited inside the rack, slide the server out part of the way to install the cable-management arm.

6.2

From the back of the rack, use the pin **A** to affix the cable-management arm **E** to the left side-rail-management arm flange **D** that is attached to the rack frame **D**.

6.3

Use the second pin **A** to affix the other end of the cable-management arm **E** to the flange **C** that is attached to the sliding portion of the left slide rail assembly **B**.

7

Cable the server and Operations Console (LAN)

Operations Console is an installable component of iSeries™ Access for Windows®. It allows you to use one or more PCs to access and control, either remotely or locally, console and control panel functions.

If you are not using Operations Console to manage your server, go to task 8 *Cable the server and the Thin Console*.

The following steps guide you through a LAN implementation of Operations Console. If you are using a local console that is directly attached, follow the setup instructions in the IBM Systems Hardware Information Center. For details about how to access the information center, see task 11 *Finish your system setup*.

If you are using a PC that is already in use as your system console, you do not need to power off the system console to complete this procedure.

Prerequisite: This task requires one or more Ethernet cables that are not supplied with your server.

7.1

If necessary, connect an Ethernet cable from the PC that will serve as the system console to your local network, router, switch, or hub.

7.2

Connect another network cable from the same local network, router, switch, or hub, to the first embedded Ethernet port (P1-T5) or the adapter card in position C5 or C2 on the back of the server.

7.3

Route the server power cord through the rings or clamps, if available, on the back of the server, and connect it to the power supply port. **Do not connect the server power cord to a power source until instructed to do so.**

7.4

If necessary, plug the power cord for your system console (PC) into a power source, and turn it on.

7.5

Install iSeries Access for Windows onto the system console using the *Setup and Operations* CD that was provided with your server. If you already have iSeries Access for Windows installed, skip to step 7.6.

1. Insert the *Setup and Operations* CD and select **iSeries Access for Windows**.
2. Click **Next** and follow the prompts when the iSeries Access for Windows window is displayed.
3. Select **Custom** or **Full** installation and select at least the following components.

Note: The Operations Console component is not available using the Typical or PC5250 User options.

- **Required Programs**
- **5250 Display and Printer Emulator**; if IBM Personal Communications V5.8 (V5.7 CSD 1 minimum) is not installed
- **Operations Console**

4. Click **Next** and follow the prompts.

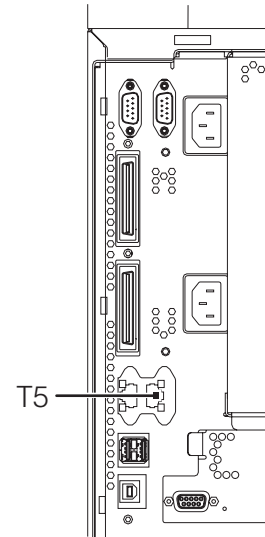

7.6

Start the Operations Console configuration wizard on the system console.

1. Click **Start > Programs > iSeries Access for Windows > Operations Console**.

2. Follow the steps in the wizard. Use the following information to enter any required data.

Service host name (interface name): Use either the name of a current network interface, or a new name for this connection.

Target partition: Enter the number **1**, even if you are not partitioning.

Serial Number: Enter the serial number located on the server control panel

Service tools device ID: Use the default value **QCONSOLE**.

Access password: Enter a password that you will remember. The password is case sensitive and can be a maximum of 128 characters.

3. Click **Finish** to save the configuration and to exit the configuration wizard.

7.7

Right-click the connection name and select **Connect** to start your connection. The system console will not complete the connection until you have completed step 7.10.

7.8

Connect your server to a power source. The control panel should be lit and display 01 B N V=F. The server is not yet powered on.

Note: If 01 B N V=F does not display, see the instructions in the IBM Systems Hardware Information Center. For details about how to access the information center, see task 11 *Finish your system setup*.

7.9

Press the white Power On button on the front of the server. There is a short delay before the server powers on, of approximately 5 to 20 minutes. When the server powers on, the control panel displays 01 B N V=F.

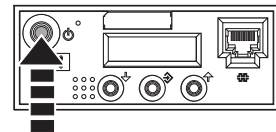

7.10

When the LAN Service Tools Sign-on window is displayed, type your access password, and then type **11111111** (eight 1's) in both the service tools user ID and password fields.

You have completed the basic setup. Go to task 11 *Finish your system setup*.

8

Cable the server and the Thin Console

The Thin Console provides a 5250 emulation session for an i5/OS® logical partition on servers that are not managed by a Hardware Management Console (HMC).

If you are not using the Thin Console to manage your server, go to task 9 *Cable the HMC and the server*.

This task assumes that you are setting up the Thin Console with a new server. If you are setting up the Thin Console with an existing server, follow the instructions in the IBM Systems Hardware Information Center. For details about how to access the information center, see task 11 *Finish your system setup*.

Prerequisite: This task requires an Ethernet cable and a monitor that are not supplied with your server.

8.1 Complete the Thin Console setup instructions provided with the Thin Console.

8.2 Select the keyboard language and press **Enter**.

8.3 Connect the other end of the Ethernet cable directly to the HMC port labeled HMC1 or the port labeled HMC2 on the back of the server. No other console device can be attached to the remaining HMC port.

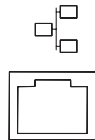

Important: Use an Ethernet cable with a maximum length of 7.5 m (25 ft.).

8.4 Route the server power cord through the rings or clamps, if available, on the back of the server, and connect it to the power supply port.

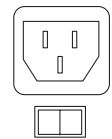

8.5 Connect your server to a power source. The control panel should be lit and display 01 B N V=F. The server is not yet powered on.

Tip: If 01 B N V=F does not display, see the instructions in the IBM Systems Hardware Information Center. For details about how to access the information center, see task 11 *Finish your system setup*.

8.6 When you are prompted on the Thin Console display, type a new HMC access password. This password is case sensitive.

8.7 Press the white Power On button on the front of the server. There is a delay before the server powers on, approximately 5 to 20 minutes. When the server powers on, the control panel displays 01 B N V=F.

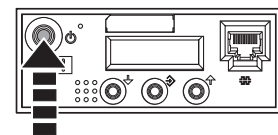

Your Thin Console is now cabled and will be ready for login when the IPL is complete. Go to task 11 *Finish your system setup*.

9

Cable the HMC and the server

An HMC is a system that connects to the server and manages it through a network.

If you are not using an HMC to manage your server, skip this task and go to task 10 *Cable the server and twinaxial console*.

If you are using a rack-mounted HMC, these steps assume it is already installed in the rack.

If you need to install the HMC into the rack, follow the instructions in the IBM Systems Hardware Information Center, and return to this guide when you are ready to begin cabling your HMC. For details about how to access the information center, see task 11 *Finish your system setup*.

9.1

If you are using any optional adapters for the HMC, connect the cables to the appropriate adapter connectors in the PCI slots of your server and HMC.

9.2

Route the power cords through the rings or clamps, if available, on the back of the server, and connect to the server, monitor, and HMC. **Do not connect the power cords to a power source until instructed to do so.**

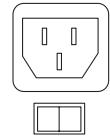

Important: Ensure that if there is a voltage switch next to the power connector on the monitor, it is in the appropriate position for the voltage used in your geography.

9.3

Connect the mouse and keyboard cables to the appropriate ports on the back of the HMC. If your mouse and keyboard use Universal Serial Bus (USB) cables, you can connect these to the ports on the front of the HMC.

9.4

Attach the monitor cable to the monitor connector on the HMC and tighten the screws.

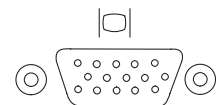

Tip: If you are using the rack-mounted LCD monitor and keyboard (7316-TF3), use the C2T-to-KVM adapter breakout cable to attach to the HMC.

9.5

If you are not using a modem, skip to step 9.6.

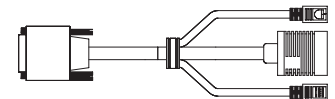

If you are using the integrated HMC modem, connect the telephone cable to the modem and to the analog jack on the wall. If you are using an external modem, connect the modem data cable to the external modem and to a serial port on the HMC. Then connect the telephone cable to the external modem and to the analog jack on the wall.

9.6

Connect the Ethernet cable to the Ethernet port on the HMC and to the Ethernet port labeled HMC1 on the server.

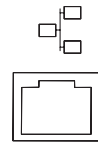

For a stand-alone HMC, use the integrated Ethernet port. For the 7310-CR2 rack-mounted HMC, use the bottom-right Ethernet port. For the 7310-CR3 rack-mounted HMC, use the left port of the two planar board Ethernet ports.

9.7

If using an external modem, plug the power cord into the modem.



CAUTION: This product is equipped with a 3-wire (two conductor and a ground) power cable and plug. Use this power cable with a properly grounded electrical outlet to avoid electrical shock. (C018)

9.8

Plug the power cords for the monitor, HMC, and external modem into a power source. Do not connect the server to a power source until instructed to do so.

9.9

Route the cables through the cable-management arm on the server and secure the cables with the straps provided.

9.10

Start and configure the HMC, which includes the Guided Setup Wizard. You can find the instructions for configuring the HMC in the IBM Systems Hardware Information Center. For details about how to access the information center, see task 11 *Finish your system setup*.

9.11

Connect the server to a power source and wait for the control panel on the front of the server to display 01. This might take several minutes.

9.12

Press the white Power On button on the control panel.

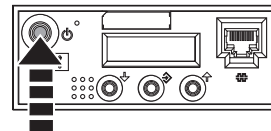

You have completed the basic setup. Go to task 11 *Finish your system setup*.

10

Cable the server and twinaxial console

If you are not using a twinaxial console to manage your server, go to task 11 *Finish your system setup*.

10.1

Route the power cords through the rings or clamps, if available, on the back of the server, and connect to the server. Do not connect the power cords to a power source until instructed to do so.

10.2

Connect the 8-port twinaxial attachment cable (Part Number 21F5093) to the twinaxial adapter card (2746). This card should be located in position 5 or 2 on the back of the server.

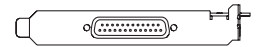

10.3

Connect a twinaxial cable from the workstation that you will be using as the system console to port 0 on the 8-port twinaxial attachment cable.

Important: The workstation address of your console must be set to 0. To set the address, see the information included with your workstation.

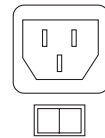

10.4

Connect one end of a telephone cable to the RJ11 connector of the adapter in position 3, and the other end to an analog telephone jack.

10.5

If you are using any optional adapters, connect the cables to the appropriate adapter connectors in the PCI slots of your server. If your server is in a rack, route the cables through the cable-management arm and secure with the straps provided.

10.6

Connect your console to a power source and turn it on.

10.7

Connect your server to a power source, and wait for the control panel on the front of the server to display 01. This might take several minutes.

10.8

Press the white Power On button on the control panel.

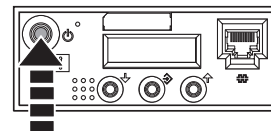

Your console is now cabled and will be ready for login when the IPL is complete. Continue to task 11 *Finish your system setup* for details about how to access the information center.

11

Finish your system setup

You have completed the basic tasks to set up your server.

You can now access the IBM Systems Hardware Information Center. Follow these steps to create a customized checklist that helps you configure your server and console, install software, apply fixes, and establish connections with your service provider:

11.1

Using a Web browser, go to www.ibm.com/systems/infocenter/hardware or go to the preinstalled version on the HMC.

11.2

From the navigation bar, click **Systems Hardware information > System p information > Initial server setup > Create a customized initial server setup checklist.**

11.3

Answer the questions in the interactive interview, and follow the procedures in the resulting checklist.

If you cannot access the online version of the information center, it is also provided on a CD with your system (SK3T-8159).



© International Business Machines Corporation 2005, 2007

Printed in USA
September 2007
All Rights Reserved

Mail comments to:
IBM Corporation
Attention Department DDR
3605 Highway 52 North
Rochester, MN U.S.A. 55901-7829

Fax comments to:
1-800-937-3430 (U.S. or Canada)
1-507-253-5192 (outside the U.S. or Canada)
Internet URL: <http://www.ibm.com/systems/infocenter/hardware>

References in this publication to IBM products or services do not imply that IBM intends to make them available in every country or region.

e (logo) server, eServer, IBM, the IBM logo, i5/OS, iSeries, and System i are trademarks of International Business Machines Corporation in the United States, other countries, or both.

Microsoft, Windows, Windows NT, and the Windows logo are trademarks of Microsoft Corporation in the United States, other countries, or both.

Other company, product, and service names may be trademarks or service marks of others.



29R1710



SA41-5163-06