

IBM ESS expansion
Version 5.3.5

Installation and User Guide - Model 084



Note

Before using this information and the product it supports, read the following information:

- The general information in [“Notices” on page 57](#)
- The information in the [“Safety and environmental notices” on page ix](#)
- The information in the *IBM Environmental Notices and User Guide* (provided on a DVD)

This edition applies to IBM ESS expansion Model 084 and is valid until replaced by new editions.

© **Copyright International Business Machines Corporation 2017, 2020.**

US Government Users Restricted Rights – Use, duplication or disclosure restricted by GSA ADP Schedule Contract with IBM Corp.

Contents

- Figures..... V**
- Tables..... vii**
- Safety and environmental notices..... ix**
 - Safety notices..... ix
 - Environmental notices.....xii
- Support information.....xiii**
- Chapter 1. Appliance safety precautions..... 1**
 - Introduction..... 1
 - Damage..... 1
 - Handling..... 1
 - Relocating an ESS racked system 5147-084 (5U84)..... 3
 - Operation.....3
 - Electrical safety.....5
 - Rack system safety precautions.....6
 - Electrostatic discharge (ESD) precautions.....7
 - Regional safety.....7
- Chapter 2. System overview..... 9**
 - Chassis..... 9
 - The enclosure core product.....10
 - Enclosure Chassis.....11
 - Power supply unit (PSU).....15
 - Cooling module.....16
 - SBB I/O module.....17
 - Enclosure management.....17
- Chapter 3. Installation.....19**
 - Preparation.....19
 - Installation.....20
 - Power cord connection.....22
 - Grounding checks.....23
 - System Configurations.....23
 - Data security.....23
- Chapter 4. Operation..... 25**
 - Before you begin.....25
 - Power on.....25
 - Ops panel LEDs.....25
 - Unit identification number.....26
 - Normal Power down.....27
 - Locking drawers.....27
- Chapter 5. Troubleshooting.....29**
 - Initial start-up problems.....29

| | |
|---|-----------|
| LEDs..... | 29 |
| Thermal sensors..... | 34 |
| Troubleshooting..... | 34 |
| Dealing with hardware faults..... | 35 |
| Firmware Updates..... | 36 |
| Chapter 6. Module replacement..... | 37 |
| Overview..... | 37 |
| General procedures..... | 38 |
| Replacing a disk drive in carrier (DDIC)..... | 40 |
| Replacing a cooling module..... | 42 |
| Replacing a power supply unit (PSU)..... | 43 |
| Replacing an SBB I/O module..... | 45 |
| Appendix A. Technical specifications..... | 49 |
| Dimensions..... | 49 |
| Weights..... | 49 |
| Components (fully populated)..... | 49 |
| Thermal..... | 50 |
| Temperature and humidity..... | 50 |
| Cooling modules..... | 50 |
| SBB I/O module..... | 50 |
| Power supply unit (PSU)..... | 50 |
| Supported drives..... | 51 |
| Shock and vibration tolerance..... | 51 |
| Appendix B. Standards and regulations..... | 53 |
| EMC qualification..... | 53 |
| Safety..... | 54 |
| Environmental and Recycling..... | 54 |
| Acoustics..... | 55 |
| AC power cords..... | 56 |
| Potential for radio frequency interference..... | 56 |
| Notices..... | 57 |
| Trademarks..... | 58 |
| Electronic emission notices..... | 59 |
| Federal Communications Commission Statement..... | 59 |
| Industry Canada Compliance Statement..... | 59 |
| Australia and New Zealand Class A Statement..... | 59 |
| European Union Electromagnetic Compatibility Directive..... | 59 |
| Germany Electromagnetic Compatibility Directive..... | 60 |
| People's Republic of China Class A Statement..... | 60 |
| Taiwan Class A Statement..... | 61 |
| Taiwan Contact Information..... | 61 |
| Japan Electronics and Information Technology Industries Association (JEITA) Notice..... | 61 |
| Japan Voluntary Control Council for Interference (VCCI) Notice..... | 62 |
| Korean Communications Commission Class A Statement..... | 62 |
| Russia Electromagnetic Interference Class A Statement..... | 62 |
| Homologation statement..... | 62 |

Figures

- 1. Chassis label (FCC compliance)..... 2
- 2. Module bay caution label..... 4
- 3. Compliance label with safety warning label..... 5
- 4. Drawer caution label..... 5
- 5. Enclosure: front view..... 9
- 6. Enclosure: rear view..... 10
- 7. Module locations..... 11
- 8. Drawer LEDs (left side only)..... 12
- 9. A disk drive in carrier (DDIC)..... 12
- 10. Enclosure operator’s panel..... 14
- 11. 2800W PSU..... 15
- 12. PSU LEDs..... 15
- 13. Cooling module..... 16
- 14. 6Gb/s SAS EBOD module..... 17
- 15. Unpacking the system..... 20
- 16. Mounting the system into a rack (left rail only)..... 21
- 17. Rear enclosure mounting..... 22
- 18. PSU Power Switch and LEDs..... 25
- 19. Ops panel LEDs..... 26
- 20. Anti-tamper locks..... 27
- 21. PSU LEDs..... 29
- 22. Cooling module LEDs..... 30
- 23. Operator’s panel LEDs..... 31

| | |
|---|----|
| 24. Drawer LEDs (left sideplane only)..... | 32 |
| 25. Drive Fault LED..... | 33 |
| 26. SBB I/O module LEDs..... | 33 |
| 27. Anti-tamper locks (shown disengaged)..... | 38 |
| 28. Opening the bottom drawer..... | 39 |
| 29. Drawer latch..... | 39 |
| 30. Drive location plan..... | 40 |
| 31. Removing a DDIC..... | 41 |
| 32. Installing a DDIC..... | 41 |
| 33. Latch position of a correctly inserted drive..... | 41 |
| 34. Cooling module LEDs..... | 42 |
| 35. Removing a Cooling Module (1)..... | 42 |
| 36. Removing a Cooling Module (2)..... | 43 |
| 37. Removing a PSU module (1)..... | 44 |
| 38. Removing a PSU Module (2)..... | 44 |
| 39. SBB I/O module LEDs..... | 45 |
| 40. Removing a module (1). (6Gb/s SAS EBOD module shown)..... | 46 |
| 41. Removing an I/O module (2)..... | 46 |

Tables

| | |
|---|----|
| 1. Table 1. Typical shipping environment..... | 3 |
| 2. Table 2. Typical storage environment..... | 3 |
| 3. Ops panel LEDs..... | 26 |
| 4. PSU LED states..... | 30 |
| 5. Cooling module LED descriptions..... | 30 |
| 6. Ops panel LED descriptions..... | 31 |
| 7. Drawer LED descriptions..... | 32 |
| 8. 6Gb/s SAS EBOD I/O Module LED Descriptions..... | 34 |
| 9. Alarm Conditions..... | 34 |
| 10. Part numbers of Field replaceable units..... | 37 |
| 11. Part numbers of Customer-replaceable units..... | 38 |
| 12. Enclosure dimensions..... | 49 |
| 13. Component weights..... | 49 |
| 14. Components..... | 49 |
| 15. Thermal specifications..... | 50 |
| 16. Temperature and humidity limits..... | 50 |
| 17. PSU specifications..... | 50 |
| 18. Supported drives for enclosure..... | 51 |
| 19. Shock and vibration tolerance..... | 51 |
| 20. Power cord specifications..... | 56 |

Safety and environmental notices

Review the safety notices, environmental notices, and electronic emission notices for IBM ESS expansion (5147-106) before you install and use the product.

Suitability for telecommunication environment: This product is not intended to connect directly or indirectly by any means whatsoever to interfaces of public telecommunications networks.

Here are examples of a caution and a danger notice. Numbers in parentheses refer to message numbers in the *IBM Safety Notices* publication G229-9054, which is included with your product.



CAUTION: A caution notice indicates the presence of a hazard that has the potential of causing moderate or minor personal injury. (C001)



DANGER: A danger notice indicates the presence of a hazard that has the potential of causing death or serious personal injury. (D002)

- [“Safety notices” on page ix](#)
- [“Environmental notices” on page xii](#)
- [“Support information” on page xiii](#)

Safety notices

Required safety notices for this product.

Familiarize yourself with the *IBM Safety Notices* publication G229-9054, which is included with your product.



DANGER: When working on or around the system, observe the following precautions:

Electrical voltage and current from power, telephone, and communication cables are hazardous. To avoid a shock hazard:

- If IBM supplied the power cord(s), connect power to this unit only with the IBM provided power cord. Do not use the IBM provided power cord for any other product.
- Do not open or service any power supply assembly.
- Do not connect or disconnect any cables or perform installation, maintenance, or reconfiguration of this product during an electrical storm.
- The product might be equipped with multiple power cords. To remove all hazardous voltages, disconnect all power cords.
- Connect all power cords to a properly wired and grounded electrical outlet. Ensure that the outlet supplies proper voltage and phase rotation according to the system rating plate.
- Connect any equipment that will be attached to this product to properly wired outlets.
- When possible, use one hand only to connect or disconnect signal cables.
- Never turn on any equipment when there is evidence of fire, water, or structural damage.
- Do not attempt to switch on power to the machine until all possible unsafe conditions are corrected.
- Assume that an electrical safety hazard is present. Perform all continuity, grounding, and power checks specified during the subsystem installation procedures to ensure that the machine meets safety requirements.
- Do not continue with the inspection if any unsafe conditions are present.
- Disconnect the attached power cords, telecommunications system, networks, and modems before you open the device covers, unless instructed otherwise in the installation and configuration procedures.

- Connect and disconnect cables as described in the following procedures when installing, moving, or opening covers on this product or attached devices.

To disconnect:

1. Turn off everything (unless instructed otherwise).
2. Remove the power cords from the outlets.
3. Remove the signal cables from the connectors.
4. Remove all cables from the devices.

To connect:

1. Turn off everything (unless instructed otherwise).
2. Attach all cables to the devices.
3. Attach the signal cables to the connectors.
4. Attach the power cords to the outlets.
5. Turn on the devices.

- Sharp edges, corners and joints may be present in and around the system. Use care when handling equipment to avoid cuts, scrapes and pinching. (D005)



DANGER: Heavy equipment—personal injury or equipment damage might result if mishandled. (D006)



DANGER: Professional movers are to be used for all relocation activities. Serious injury or death may occur if systems are handled and moved incorrectly. (D008)



DANGER: Serious injury or death can occur if loaded lift tool falls over or if a heavy load falls off the lift tool. Always completely lower the lift tool load plate and properly secure the load on the lift tool before moving or using the lift tool to lift or move an object. (D010)

Do not: Throw or immerse into water, heat to more than 100°C (212°F), repair or disassemble. (C003) Use the following general safety information for all rack mounted devices:



DANGER: Observe the following precautions when working on or around your IT rack system:

- Heavy equipment—personal injury or equipment damage might result if mishandled.
- Always lower the leveling pads on the rack cabinet.
- Always install stabilizer brackets on the rack cabinet.
- To avoid hazardous conditions due to uneven mechanical loading, always install the heaviest devices in the bottom of the rack cabinet. Always install servers and optional devices starting from the bottom of the rack cabinet.
- Rack-mounted devices are not to be used as shelves or work spaces. Do not place objects on top of rack-mounted devices.



- Each rack cabinet might have more than one power cord. Be sure to disconnect all power cords in the rack cabinet when directed to disconnect power during servicing.
- Connect all devices installed in a rack cabinet to power devices installed in the same rack cabinet. Do not plug a power cord from a device installed in one rack cabinet into a power device installed in a different rack cabinet.
- An electrical outlet that is not correctly wired could place hazardous voltage on the metal parts of the system or the devices that attach to the system. It is the responsibility of the customer to ensure that the outlet is correctly wired and grounded to prevent an electrical shock. (R001 part 1 of 2)

(R001 part 2 of 2):



CAUTION:

- Do not install a unit in a rack where the internal rack ambient temperatures will exceed the manufacturer's recommended ambient temperature for all your rack-mounted devices.
- Do not install a unit in a rack where the air flow is compromised. Ensure that air flow is not blocked or reduced on any side, front, or back of a unit used for air flow through the unit.
- Consideration should be given to the connection of the equipment to the supply circuit so that overloading of the circuits does not compromise the supply wiring or overcurrent protection. To provide the correct power connection to a rack, refer to the rating labels located on the equipment in the rack to determine the total power requirement of the supply circuit.
- (For sliding drawers.) Do not pull out or install any drawer or feature if the rack stabilizer brackets are not attached to the rack. Do not pull out more than one drawer at a time. The rack might become unstable if you pull out more than one drawer at a time.



- (For fixed drawers.) This drawer is a fixed drawer and must not be moved for servicing unless specified by the manufacturer. Attempting to move the drawer partially or completely out of the rack might cause the rack to become unstable or cause the drawer to fall out of the rack. (R001 part 2 of 2)



DANGER: Multiple power cords. The product might be equipped with multiple power cords. To remove all hazardous voltages, disconnect all power cords. (L003)



or



or



CAUTION:

The weight of this part or unit is more than 55 kg (121.2 lb). It takes specially trained persons, a lifting device, or both to safely lift this part or unit. (C011)





CAUTION: High levels of acoustical noise are (or could be under certain circumstances) present.

Use approved hearing protection and/ or provide mitigation or limit exposure. (L018)

Environmental notices

This information contains all of the required environmental notices for IBM Systems products in English and other languages.

The [IBM Systems Environmental Notices](#) information includes statements on limitations, product information, product recycling and disposal, flat panel display, battery removal and disposal, refrigeration and water-cooling systems, external power supplies, and safety data sheets.

Support information

| Your location | Method of contacting the IBM Support Center |
|---------------------------|--|
| In the United States | Call 1-800-IBM-SERV for support. |
| Outside the United States | Contact your local IBM Support Center or see the Directory of worldwide contacts . |

Chapter 1. Appliance safety precautions

Observe physical, electrical, and electronic component safety precautions.



DANGER: An electrical outlet that is not correctly wired could place hazardous voltage on the metal parts of the system or the devices that attach to the system. It is the responsibility of the customer to ensure that the outlet is correctly wired and grounded to prevent an electrical shock. (D004)

DANGER: Multiple power cords. The product might be equipped with multiple power cords. To remove all hazardous voltages, disconnect all power cords. (L003)

Introduction



CAUTION: This equipment must be used in the manner specified in this document and any related documentation. Failure to do so may bypass the protection provided by the equipment.

Damage

If you think the equipment is damaged in any way, remove all external cords and cables and contact your equipment supplier.

Handling



CAUTION: A fully configured enclosure weighs up to 135kg (298lb). An unpopulated enclosure weighs 46kg (101lb). Use appropriate lifting methods.

The packaging includes lifting straps wrapped and buckled around the enclosure. Ensure the lifting straps buckle is properly closed, and lift with the loops attached to the lifting straps.

CAUTION:



or



or



The weight of this part or unit is more than 55 kg (121.2 lb). It takes specially trained persons, a lifting device, or both to safely lift this part or unit. (C011)

The following artwork might be only a draft. The use of certification marks on a product must be authorized by the respective National Certification Bodies (NCBs) that own the marks.

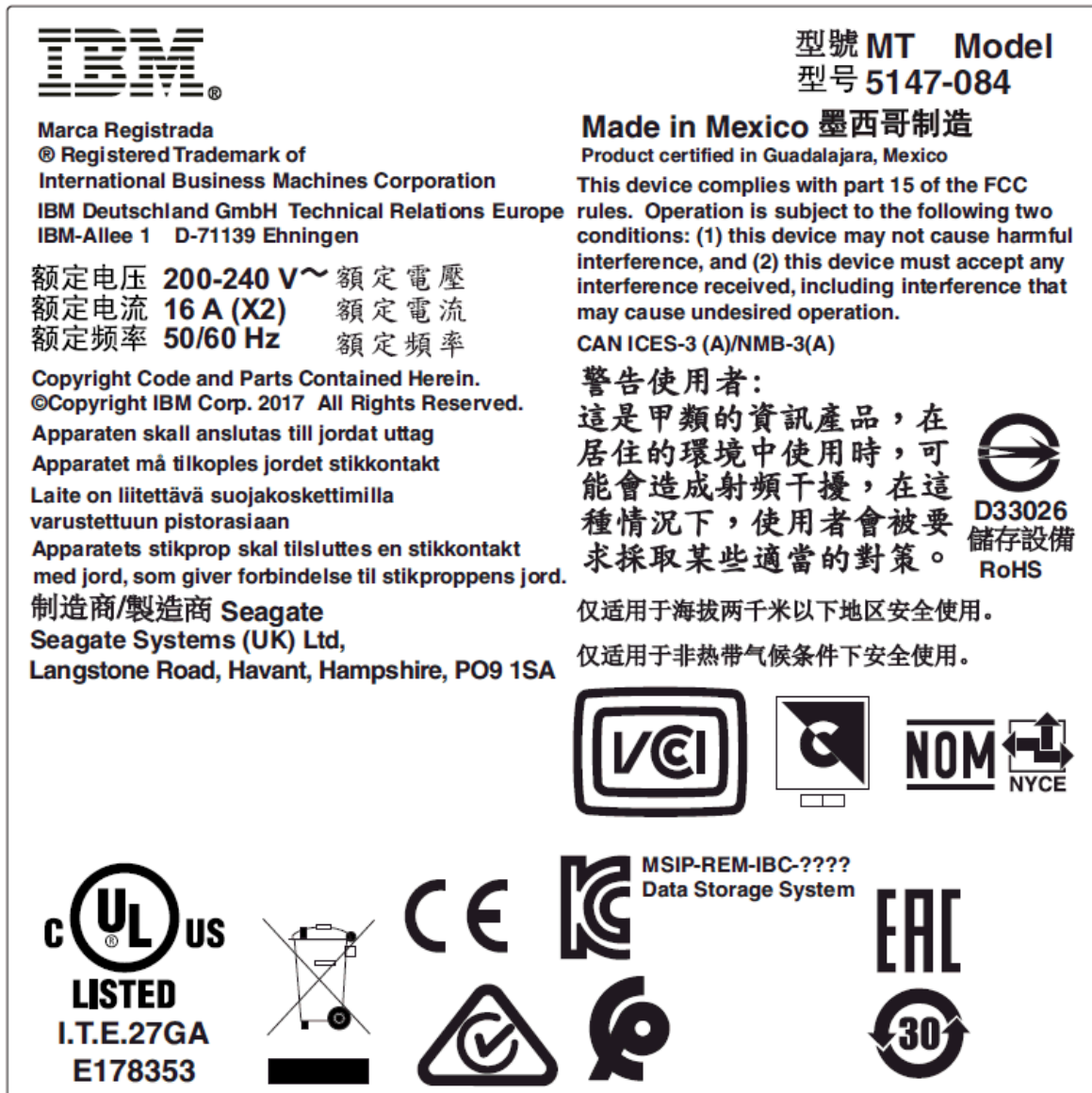

Figure 1. Chassis label (FCC compliance)

Before lifting the enclosure, complete the following tasks:

- Unplug all cords and cables from the enclosure.
- Remove all DDIC modules from both drawers and make sure the drawers are closed firmly and locked shut. See "Locking drawers."

Use a minimum of three people to lift the enclosure.

CAUTION: A fully configured enclosure weighs up to 135kg (298lb). An unpopulated enclosure weighs 46kg (101lb). Use appropriate lifting methods. The packaging includes lifting straps wrapped and buckled around the enclosure. Ensure the lifting straps buckle is properly closed, and lift with the loops attached to the lifting straps.

Do not lift the enclosure by the handles on the power supply units, cooling modules, or I/O modules. They are not designed to take the weight.

Do not lift the enclosure higher than 20U (35 in.). Use mechanical assistance to lift above this height.

Relocating an ESS racked system 5147-084 (5U84)

Important: Relocation of this enclosure is not a Customer action. You must contact IBM service (www.ibm.com/planetwide) to relocate this enclosure. Loss of data or system damage may result if IBM service does not perform the relocation action.

Shipment or storage conditions that exceed the specified limits can cause permanent damage to your server. These guidelines should be followed when relocating or temporarily storing your server.

Care should be taken to ensure that a server is not stored with chemicals that can cause corrosion damage.

When a server is removed in preparation for shipment or storage, use the packaging bill of material. This might include a protective package, including blocks, braces, and preparation instructions, designed uniquely for each server. This is available from any IBM® branch office. IBM large processors are designed for operation in a controlled temperature and relative humidity range, and require the environment be kept within this range even when they are in a storage area or in transit. See the individual server specifications for operating environment limits. Shipment of large processors should be in an environmentally controlled van with appropriate strapping and padding to avoid any transit damage.

| Properties | Shipping environment |
|-------------------|------------------------------|
| Temperature | -40°C - 60°C (-40°F - 140°F) |
| Relative humidity | 5% to 100% (no condensation) |
| Maximum wet bulb | 1°C - 27°C (33.8°F - 80.6°F) |

If shipping a large processor in a nonenvironmentally controlled van, contact your seller for packing and unpacking instructions.

| Properties | Storage environment |
|-------------------|------------------------------|
| Temperature | 1°C - 60°C (33.8°F - 140°F) |
| Relative humidity | 5% - 80% |
| Maximum wet bulb | 1°C - 29°C (33.8°F - 84.2°F) |

Operation

Important: All rear modules are part of the fire enclosure and must only be removed when a replacement can be immediately inserted.

Important: The enclosure does not receive sufficient airflow or cooling if it is operated with any of the rear modules missing. It is essential that every module bay be filled either with a module or a blank module. Each row of drive bays must be completely empty or completely full.



Figure 2. Module bay caution label

Replace any defective modules with fully operational units as soon as possible. Do not remove cooling modules, PSUs, or I/O modules unless you have a replacement model of the correct type ready for insertion. For replacement procedures, see [Chapter 6, “Module replacement,”](#) on page 37.



CAUTION: To prevent overturning, drawer interlocks stop users from opening both drawers at the same time. Do not attempt to force open a drawer when the other drawer in the enclosure is already open. In a rack containing more than one enclosure, do not open more than one drawer per rack at a time.



CAUTION: Operating temperatures inside the enclosure drawers can reach up to 60°C. Take care when opening drawers and removing drive carriers.



CAUTION: A hot surface nearby. (L007)



CAUTION: High levels of acoustical noise are (or could be under certain circumstances) present. Use approved hearing protection and/ or provide mitigation or limit exposure. (L018)



Figure 3. Compliance label with safety warning label

 **CAUTION:** Before removing a PSU module, disconnect the power cord from that module. Otherwise, modules at the rear of the enclosure are hot-swappable.

Do not use open drawers to support any other equipment.

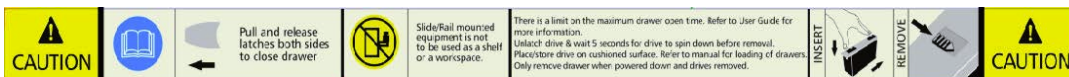

Figure 4. Drawer caution label

Electrical safety

Operate the enclosure from a power supply input voltage range of 200 to 240 VAC, 50 to 60 Hz only.

A suitable power source with electrical overload protection must be provided in order to meet the requirements in the technical specification.

All power supply cords must have a safe electrical ground connection. Check the connection to ground of the enclosure before you switch on the power supply.

Important: The enclosure must be grounded before applying power.

The plug on the power supply cord is used as the main disconnect device. Ensure that the socket outlets are located near the equipment and are easily accessible.

 **CAUTION:** When powered by multiple AC sources, unplug all power supplies to ensure disconnection.

 **DANGER:** Do not remove covers from the enclosure or any of the modules. There is a danger of electric shock inside. Do not attempt to disassemble the rear sub-chassis from the enclosure. Return any damaged components to your supplier for repair.



 **DANGER:** Hazardous voltage, current, or energy levels are present inside any component that has this label attached. Do not open any cover or barrier that contains this label. (L001)



DANGER: An electrical outlet that is not correctly wired could place hazardous voltage on the metal parts of the system or the devices that attach to the system. It is the responsibility of the customer to ensure that the outlet is correctly wired and grounded to prevent an electrical shock. (D004)



DANGER: Multiple power cords. The product might be equipped with multiple power cords. To remove all hazardous voltages, disconnect all power cords. (L003)



DANGER: HIGH LEAKAGE CURRENT. Earth connection essential before connecting supply.



CAUTION: The PSUs contain double pole/neutral fusing. Ensure that your electrical installation can support this type of fusing.

Important: If the enclosure is equipped with I/O modules having an RJ45 socket, that socket is for Ethernet connection only and must not be connected to a telecommunications network.

Rack system safety precautions

The enclosure must be mounted in a rack before use.

The rack must be capable of supporting the total weight of the installed enclosure(s). A fully populated enclosure weighs up to 135kg (298lbs). The design should incorporate stabilizing features suitable to prevent the rack from tipping or being pushed over during installation or in normal use.

When loading a rack with enclosures, fill the rack from the bottom up. When removing enclosures, empty from the top down.



CAUTION: The enclosure must be mounted into a rack using the supplied rail kit only. Due to its weight and length, the enclosure must not be flange mounted.

Before mounting the enclosure, remove all DDIC modules from both drawers and make sure the drawers are closed firmly and locked shut. Do not try to lift the enclosure by yourself (see "Handling").



CAUTION: Never move more than one enclosure out of the rack at any one time. There is a danger of the rack falling over.

The system must be operated with low pressure rear exhaust installation. The back pressure created by the rack doors and obstacles is not to exceed 5 pascals (0.5mm water gauge).

The minimum open area for the rack doors is 70%.

The rack design should take into consideration the maximum operating ambient temperature for the enclosure, which is 35°C.

The rack must have a safe electrical distribution system. It must provide overcurrent protection for the enclosure and must not be overloaded by the total number of enclosures installed in the rack. When addressing these concerns, consideration should be given to the electrical power consumption rating shown on the nameplate.

The electrical distribution system must provide a reliable ground for each enclosure, and for the rack.

Each PSU in each enclosure has a ground leakage current of 1.6mA. The design of the electrical distribution system must take into consideration the total ground leakage current from all the PSUs in all the enclosures. The rack must be labeled with the words: “HIGH LEAKAGE CURRENT. Ground connection essential before connecting supply.”

The rack must meet the safety requirements of UL 60950-1 and IEC 60950-1.



DANGER: Rack-mounted devices are not to be used as shelves or work spaces. (L002)



CAUTION: Do not pull out more than one drawer at a time. The rack might become unstable if you pull out more than one drawer at a time. (L024)

Electrostatic discharge (ESD) precautions

Fit and check a suitable anti-static wrist or ankle strap and observe all conventional ESD precautions when handling plug-in modules and components. Avoid contact with backplane components and module connectors.

Regional safety

For North American use, the branch circuit must be rated for 20A.

This equipment is suitable for connection to an IT power system (Norway).

Chapter 2. System overview

Chassis

The system is housed in a 5U chassis containing two drawers of 42 drives each (84 drives in total). The system is shown in the following figures.



Figure 5. Enclosure: front view

The system uses 3.5" or 2.5" SAS drives. 2.5" drives require a 3.5" adapter. Each drive is hotpluggable and can be replaced on site.

This enclosure is designed for high availability, with no single point of failure for data or power. It complies to the Storage Bridge Bay (SBB) v2.0 specification, which specifies interconnects, power budgets, power rails, mechanical and thermal form factors and footprints.

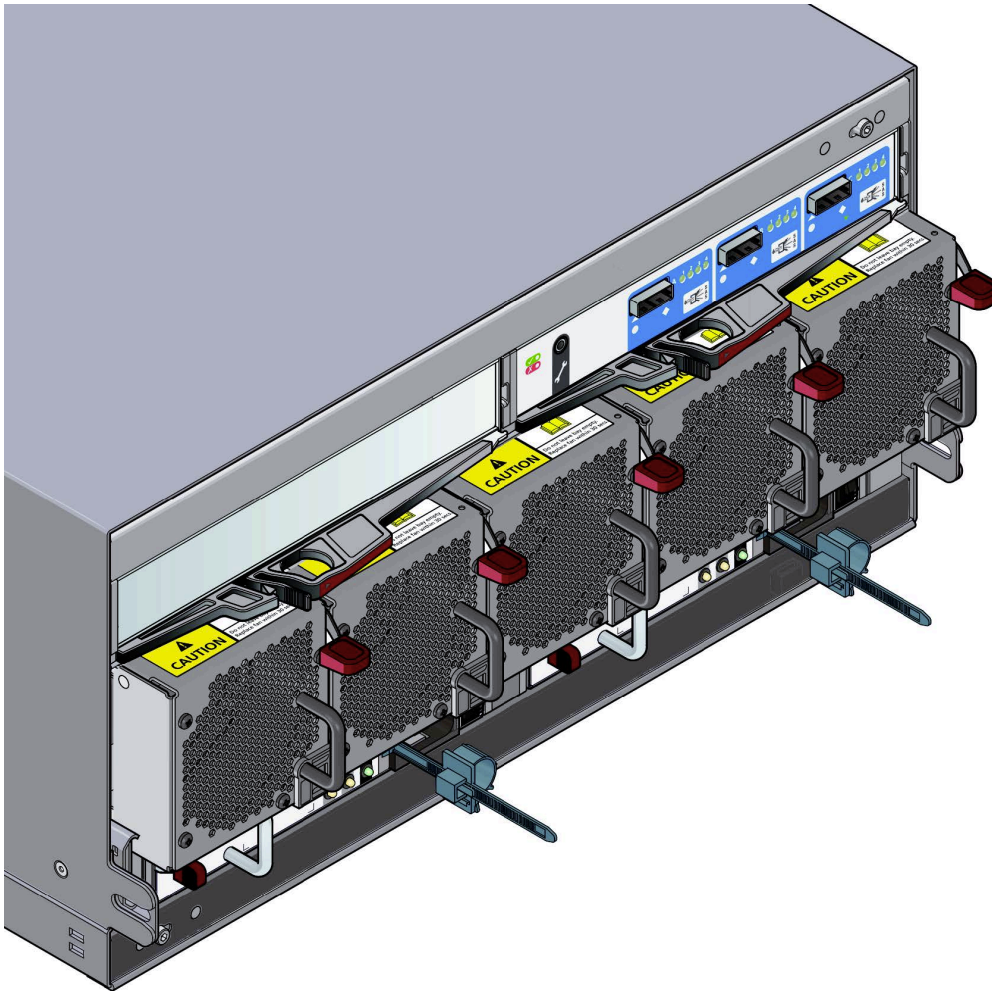

Figure 6. Enclosure: rear view

The enclosure core product

The IBM ESS expansion design concept is based on an enclosure subsystem together with a set of plug-in modules.

A typical enclosure system for direct dock comprises:

- An enclosure chassis comprising the following parts:
 - Two sliding drawers containing Disk Drive In Carrier (DDIC) modules
 - An operator's (ops) panel
 - A front bezel
 - A midplane PCB into which other components connect
- Two Power Supply Units (PSUs).
- Five cooling modules.
- Two SBB I/O modules.
- Up to 84 Disk Drive In Carrier (DDIC) modules with drives installed.
- A rail kit for rack mounting.

Important: To ensure correct airflow and cooling, all PSU bays and cooling module bays must contain a functioning unit. If the enclosure is run with a single SBB I/O module, the other I/O module bay must be filled with a blank module. Each row of drive bays must be completely empty or completely full.

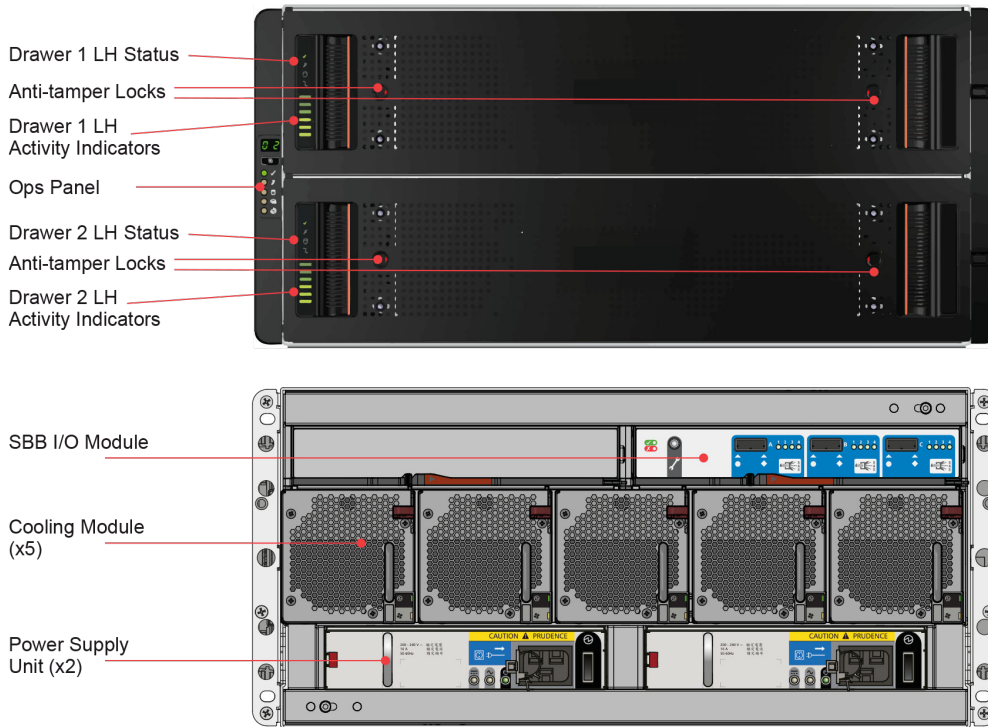

Figure 7. Module locations

Enclosure Chassis

The chassis consists of a sheet metal enclosure assembly with an integrated midplane PCB, module runner system, and two drawers for drive modules.

The chassis has a 19 inch rack mounting that enables it to be installed on to standard 19 inch racks and uses 5 EIA units of rack space (8.75 inches; 222mm).

Each drawer contains 42 bays for Disk Drives in Carriers (DDICs). DDICs are top-mounted into the drawers.

At the rear, the chassis assembly can accept two PSUs, two SBB I/O modules and five cooling modules.

Drawers

Each drawer contains 42 slots, each of which accepts a single DDIC containing a 3.5" drive or a 2.5" drive with an adapter..

Opening a drawer does not interrupt the functioning of the system, and DDICs can be hotswapped while the enclosure continues to operate. However, drawers must not be left open for longer than 10 minutes, otherwise airflow and cooling will be compromised.

The drawer is designed to support its own weight, plus the weight of any drives, when fully open.

The following safety features are included:

- To reduce the possibility of toppling, only one drawer can be open at any one time.
- The drawer locks into place when opened all the way. To reduce pinching hazards, two latches must be released before the drawer can be pushed back in.

Power and data are sent via three baseplanes and two sideplanes.

Each drawer can be locked shut by turning both anti-tamper locks clockwise using a screwdriver with a Torx T20 bit (see [Figure 7](#) on page 11). Each side of each drawer has a series of status LEDs, shown in the following figure.

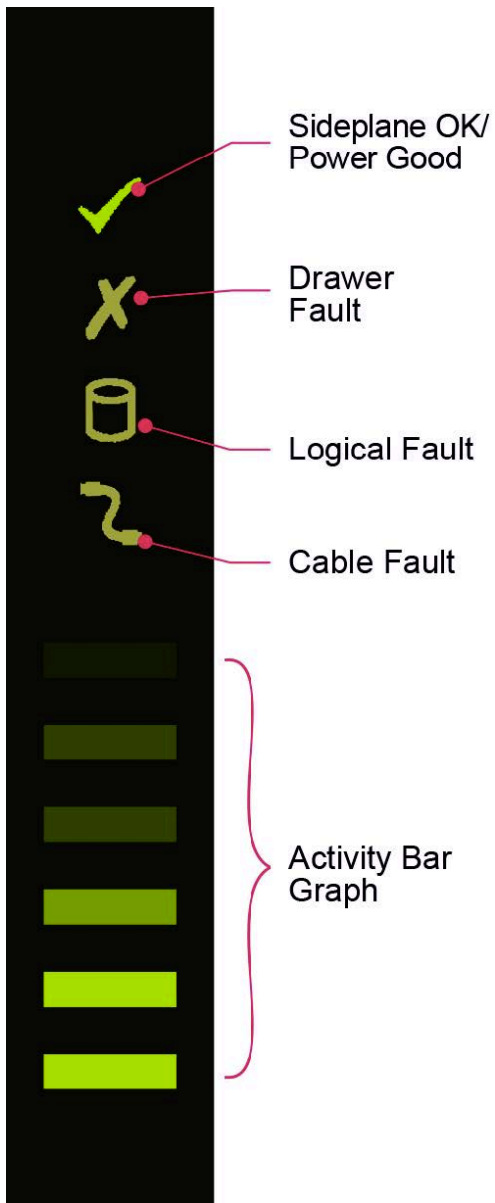

Figure 8. Drawer LEDs (left side only)

Important: During normal operation, drawers must be kept shut to ensure correct airflow and cooling.

Disk drives in carriers (DDICs)

Each drive is housed in a carrier (see the following figure) that enables secure insertion of the drive into the drawer and contains the appropriate transition card:

- SAS carrier transition card.

Figure 9. A disk drive in carrier (DDIC)

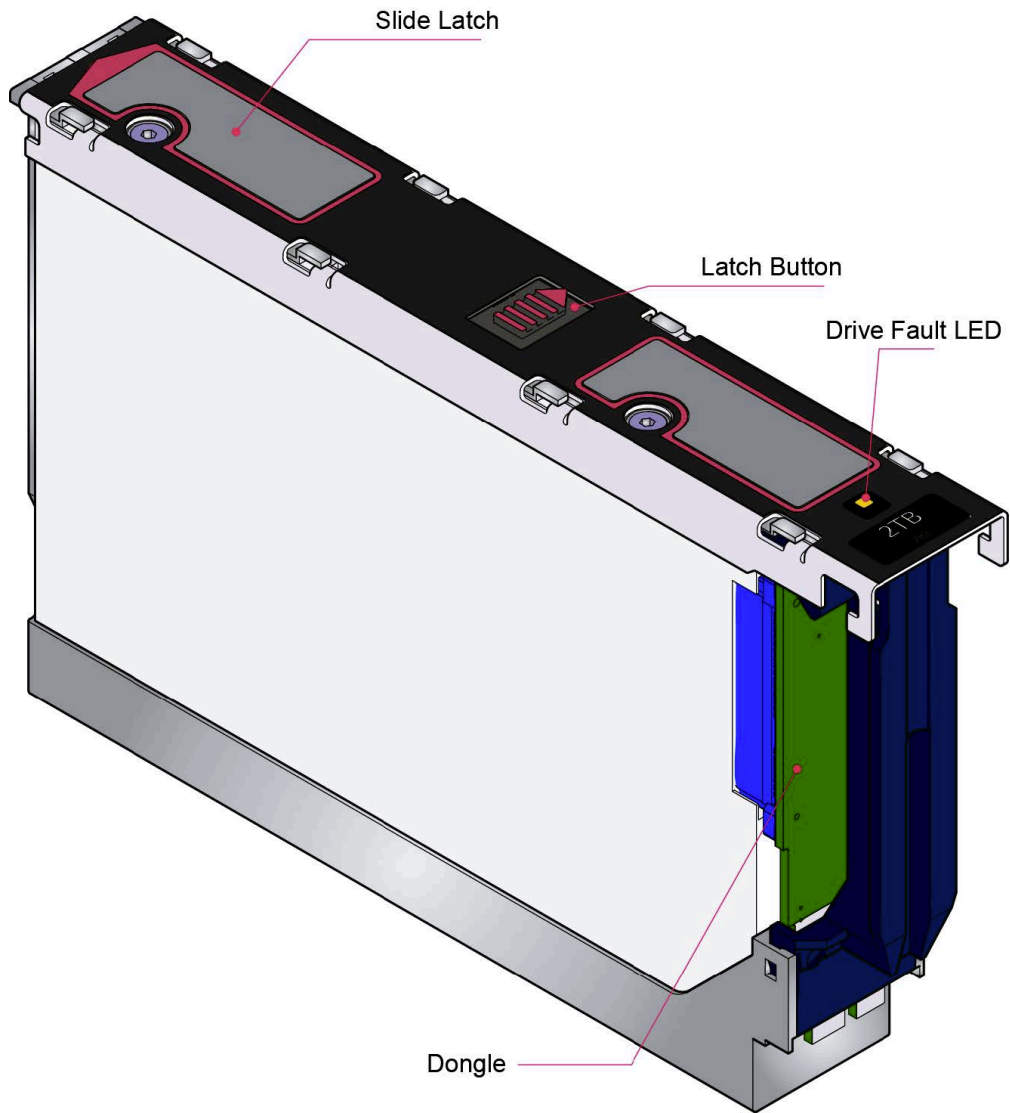

The following hard disk drives are supported:

- 3.5" 7200rpm SAS drive

The following solid state drives are supported:

- 2.5" SAS solid state drive with 3.5" adapter

Note: SSD drives are supported only for logtip backup. For details, see Spectrum Scale RAID Administration.

The drive carrier has a single amber LED which is lit when the drive has a fault.

Operator's panel

The front of the enclosure features an operator's (ops) panel (shown in Figure 2–6) on the left-hand side which contains the following:

- Unit Identification Display.
- Mute/Input button.
- Power On/Standby LED (green/amber).
- Module Fault LED (amber).
- Logical Status LED (amber).
- Drawer 1 Fault LED (amber).

- Drawer 2 Fault LED (amber).

The ops panel is an integral part of the chassis, and is not replaceable on site.

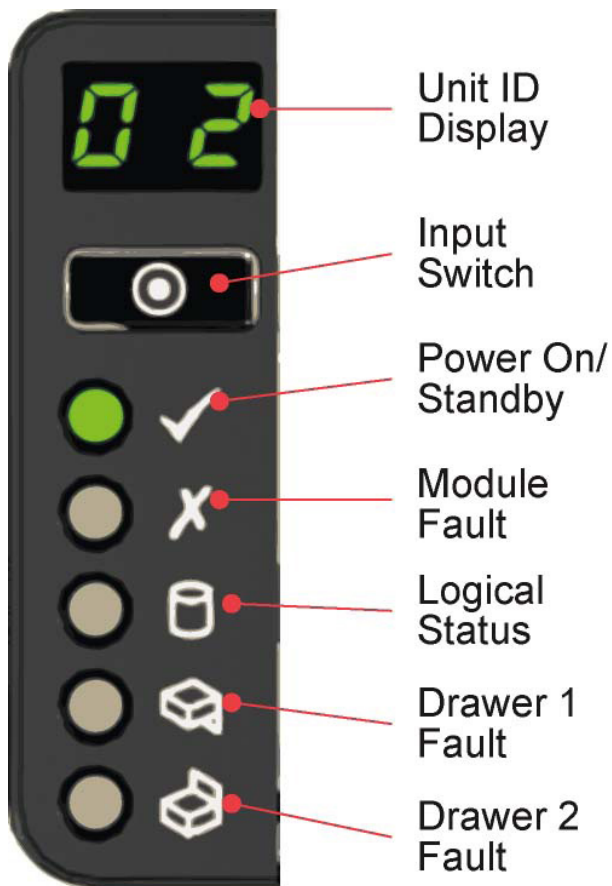

Figure 10. Enclosure operator's panel

Unit Identification Display

A numerical display whose primary function is to display the enclosure unit identification number. This can be helpful when setting up and maintaining multiple enclosure systems.

However, a VPD (Vital Product Data) option allows the unit identification display to be configured for other purposes. The display will be on by default, and display a value of 0. See ["Unit identification number"](#) on page 26.

Mute/Input button

Used to set the unit identification display. See "How To Set the Unit Identification Number."

Power On/Standby LED (green/amber)

Shows amber when the system is in standby (not operational). Shows green when the system is on (operational).

Module Fault LED (amber)

Shows amber when there is a system hardware fault. Additionally, an LED may be lit on a PSU, drawer, DDIC, cooling module, or I/O module that helps you identify which component is at fault.

Logical Status LED (amber)

Indicates a change of status or fault from something other than the enclosure management (EM) system. This may be from an internal or external RAID controller or HBA. It is usually associated with a disk drive and LEDs at each disk drive position help you identify the drive affected.

Drawer 1 Fault LED (amber)

Indicates a drive, cable, or sideplane fault in drawer 1.

Drawer 2 Fault LED (amber)

Indicates a drive, cable, or sideplane fault in drawer 2.

The ops panel is an integral part of the chassis, and is not replaceable on site.

Power supply unit (PSU)

Power is provided by two 2800W PSUs. These units require an input of 200 to 240VAC at 50 to 60Hz.

The following figure shows the PSU.

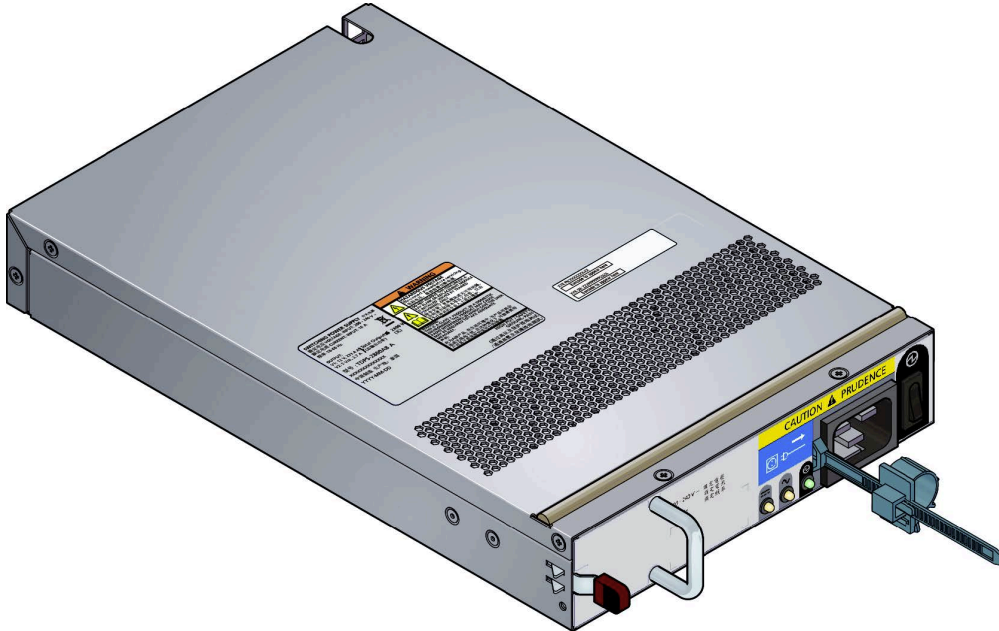

Figure 11. 2800W PSU

Dual PSUs provide redundant power for the system: if one PSU fails, the other will keep the system running while you replace the faulty module. The PSUs are hot-swappable. Replacement of a PSU can be performed while the enclosure is running, but the procedure must be completed within two minutes of the removal of the defective PSU. Ensure you have a replacement PSU before you remove the defective PSU. For the replacement procedure, see [“Replacing a power supply unit \(PSU\)”](#) on page 43.

The enclosure chassis is keyed to prevent PSUs from being inserted upside down.

The back of the PSU has a power switch, three status LEDs and a socket for the power cord, as shown in the following figure.

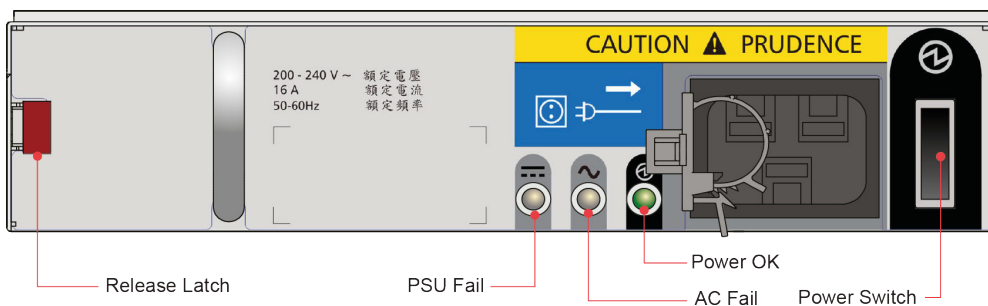

Figure 12. PSU LEDs

Cooling module

The five cooling modules at the rear of the enclosure maintain all system components below their maximum temperature, assuming the ambient temperature is below 95° F (35°C).

The speed of the fans in the cooling modules is controlled by the SSB I/O modules. For more information about the system airflow, see “System airflow” on page 16.

Cooling modules can be hot-swapped while the enclosure is still running, assuming that only one module is removed at a time and the swap takes no longer than two minutes. Ensure you have a replacement cooling module before you remove the defective cooling module.

The following figure shows a cooling module.

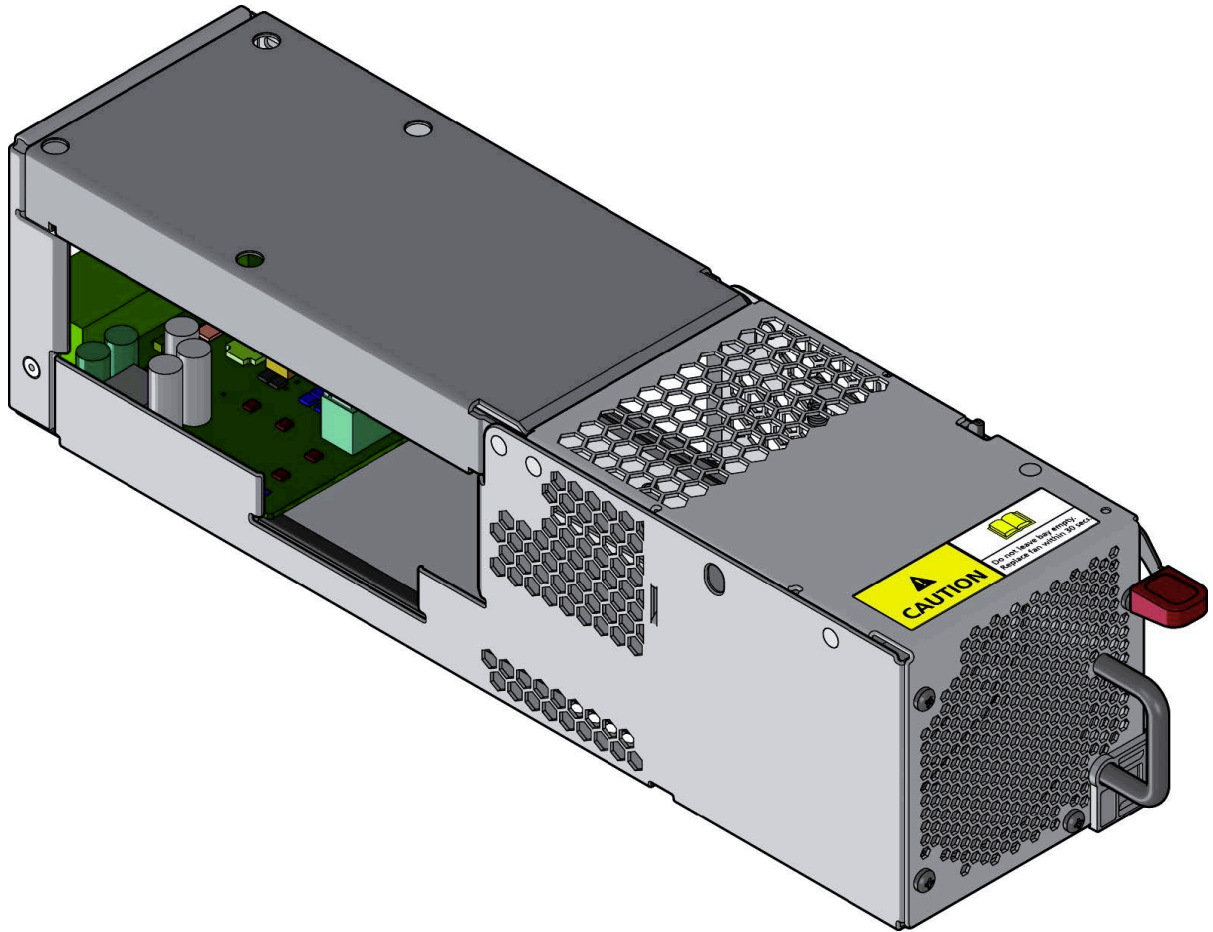

Figure 13. Cooling module

System airflow

The system must be operated with low pressure rear exhaust installation. Back pressure created by the rack doors and obstacles is not to exceed 5 pascals (0.5mm water gauge). The cooling system provides sufficient capacity to ensure that maximum temperatures are not exceeded.

The minimum open area for the rack doors is 70%.

SBB I/O module

The platform has a variety of SBB I/O module options. Refer to the specific SBB I/O module documentation for details.

All SBB I/O modules are mechanically and electrically compliant to the SBB V2 specification.

The following figure shows a typical SBB I/O module.

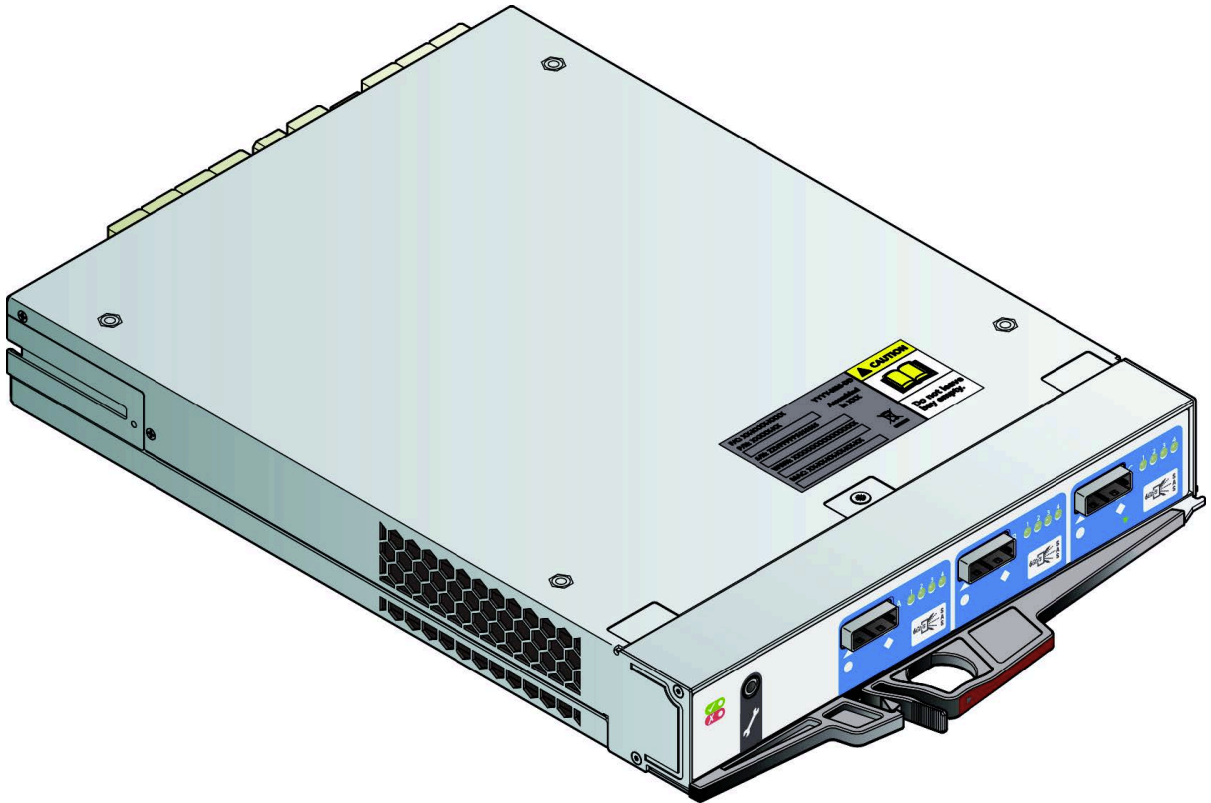

Figure 14. 6Gb/s SAS EBOD module

The system can operate with one or two modules. If the enclosure is run with a single module, the other I/O module bay must be filled with a blank module. The presence of I/O modules is checked when the power is switched on. The enclosure will not power up if there are no I/O modules present. An alarm occurs when incompatible configurations are detected.

The enclosure chassis is keyed to prevent I/O modules from being inserted upside down.

Enclosure management

SBB I/O modules actively manage the enclosure. If one of the modules fails in a two module system, the other module will continue to operate.

Chapter 3. Installation

Preparation

Before you start, familiarize yourself with the required safety precautions.

Important: Before you attempt to install the system, read [“Safety and environmental notices”](#) on page ix and [Chapter 1, “Appliance safety precautions,”](#) on page 1.

Important: The enclosure must be mounted in a rack before use.

Important: Only service personnel should install the system.

ESD precautions

Fit and check a suitable anti-static wrist or ankle strap and observe all conventional ESD precautions when handling plug-in modules and components. Avoid contact with backplane components and module connectors.

Site requirements

Before you begin, make sure the site where you intend to set up and use your storage system has the following utilities and equipments:

- Standard power from an independent source or a rack power distribution unit.
- ESS IO Server nodes with correct software.

Before setting up your enclosure, ensure ESS I/O server nodes have the SAS HBA installed in the correct slot. Ensure that you have the following equipment:

- Mini SAS to mini SAS HD cable
- Power cord
- Rack kit

The accessory box contains the power cords and other ordered accessories.

Unpacking the system



CAUTION: A fully configured enclosure weighs up to 135kg (298lb). An unpopulated enclosure weighs 46kg (101lb). To lift the enclosure out of the shipping box, use appropriate lifting methods. The packaging includes lifting straps wrapped and buckled around the enclosure. Make sure the lifting strap buckle is properly closed, and lift with the loops attached to the lifting straps.

1. Position the shipping case within 2m (6 feet) of the site where you intend to use your storage system.
2. Inspect the packaging for crushes, cuts, water damage or any other evidence of mishandling during transit. If there is any damage, photograph the packaging for future reference before opening.
3. Remove the packaging, as shown in the following figure.

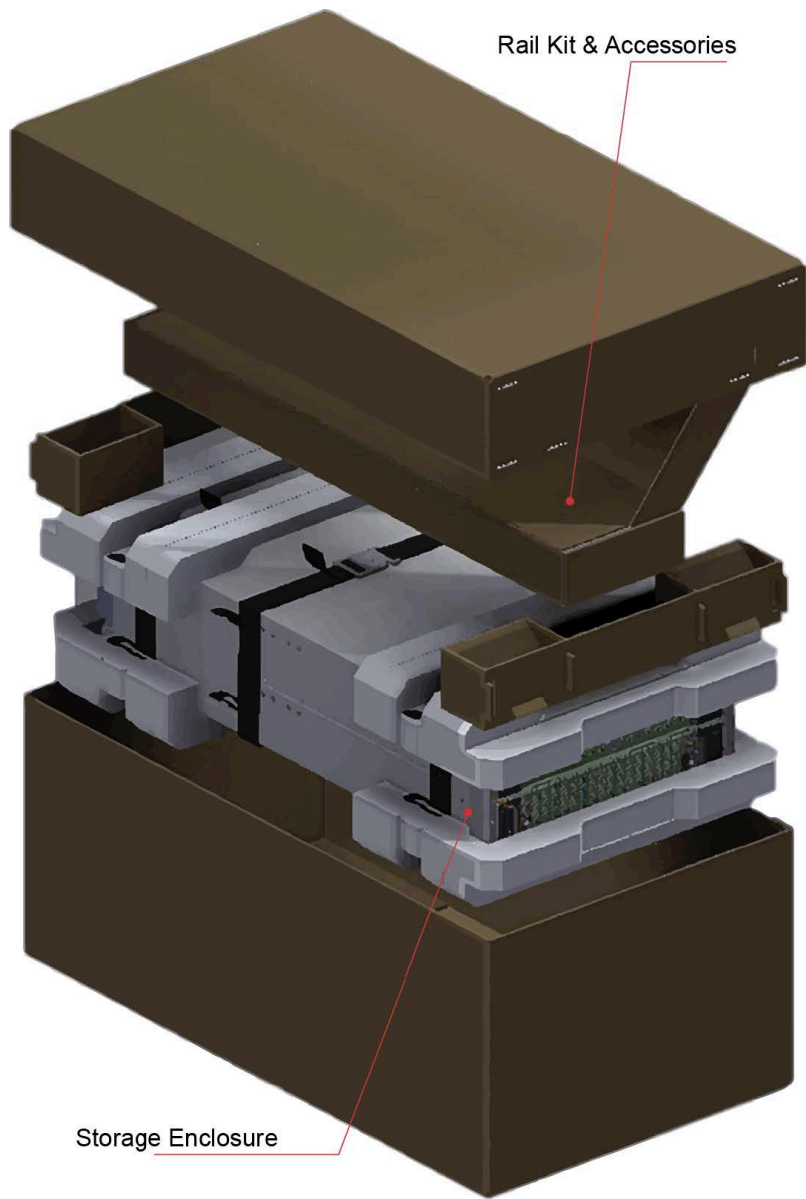

Figure 15. Unpacking the system

Installation

First, install the rail kit, then install the modules.

Installing the rail kit



CAUTION: An unpopulated enclosure can weigh up to 46kg (101lb). Do not try to lift it by yourself.

Due to the weight of the enclosure, install it without the drive carriers.

The adjustment range of the rail kit, from the inside of the front post to the inside of the rear post is 660mm - 840mm. This suits a one meter deep rack within Rack Specification IEC 60297.

1. To facilitate access, remove the door from the rack.
2. Ensure the pre-assembled rails are at their shortest length.

3. Locate the rail location pins inside the front of the rack and extend the length of the rail assembly to enable the rear location pins to locate. Ensure the pins are fully located in the square or round holes in the rack posts, as shown in the following figure.

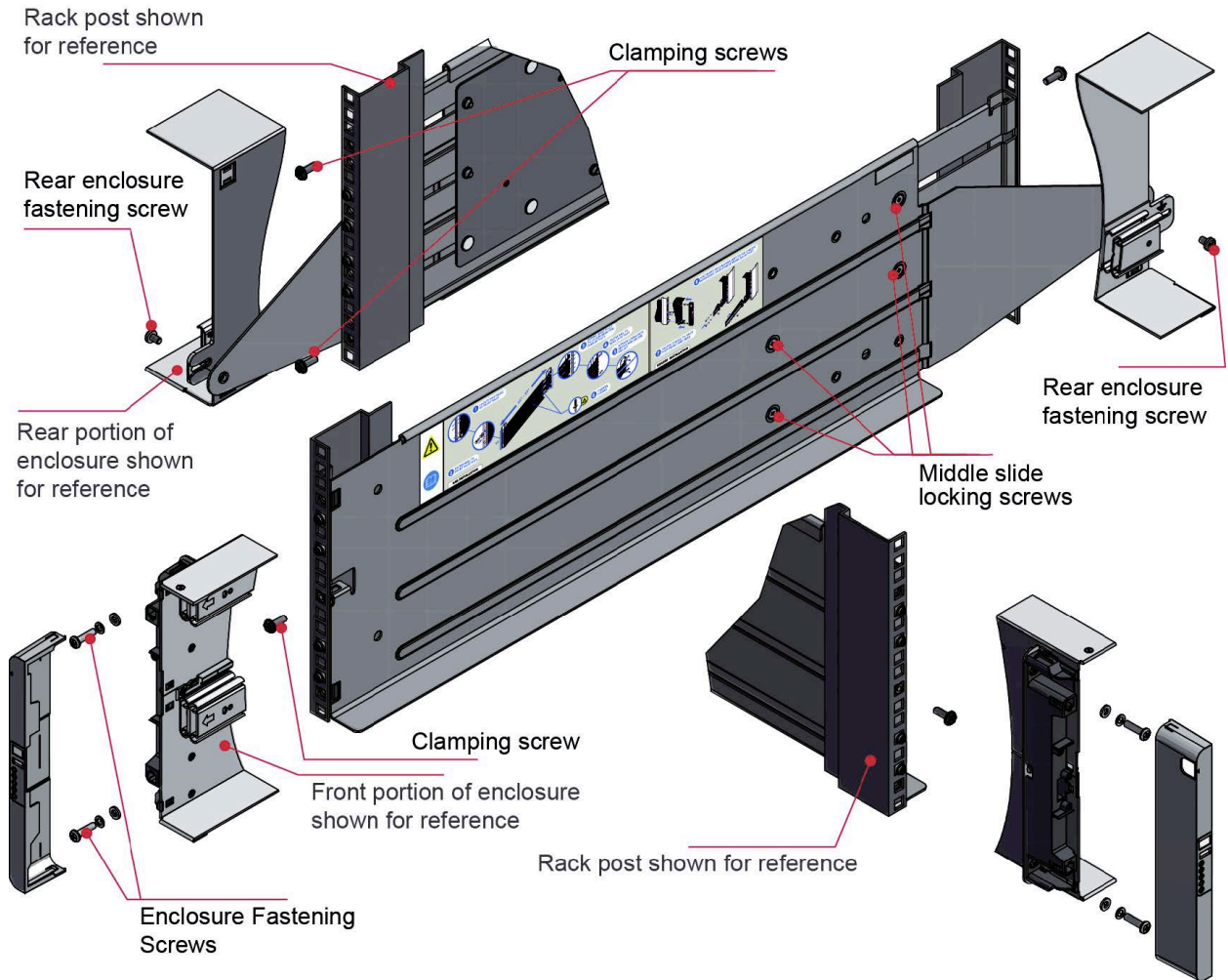

Figure 16. Mounting the system into a rack (left rail only)

4. Fully tighten all clamping screws and middle slide locking screws.
5. Ensure the rear spacer clips (x4) are fitted tight to the edge of the rack post.
6. Slide the enclosure fully home on its rails.
7. Fasten the front of the enclosure using the enclosure fastening screws (x4).
8. Fix the rear of the enclosure to the hold-down bracket with the rear enclosure fixing screws (x2).

Note: Use the long or short hold-down bracket depending on the distance from the rack post to the enclosure hold-down slot. Ensure the sliding nut is at the rear of the slot prior to fitting the bracket to the post, then slide the nut along the slot to enable the rear enclosure fastening screw to be fitted.

Note: For rack depths where the rack posts are behind the enclosure hold-down slots:

1. Swap the left and right hold-down brackets.
2. Insert the long flange between the rack post and chassis side, as shown in the following figure.

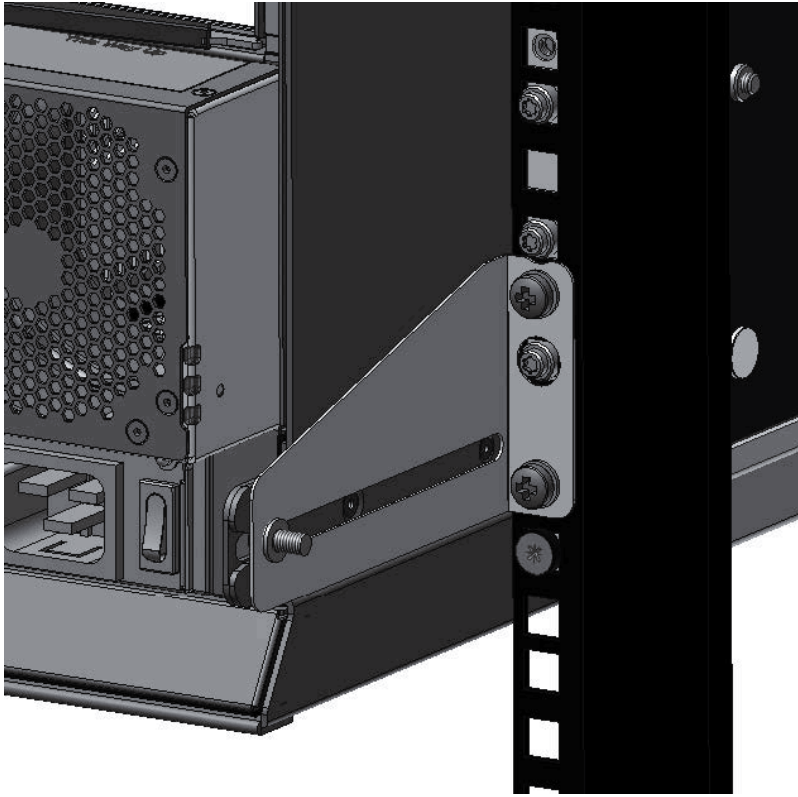

Figure 17. Rear enclosure mounting

3. The sliding nut head must always face away from the enclosure, whichever configuration is used.



CAUTION: Use only the power cords supplied or cords that match the specification in Appendix B, "AC power cords."



CAUTION: After the enclosure is installed in the rack, dispose of the lifting straps. Due to the difficulty in attaching the straps once the enclosure is installed in the rack, the straps are not suitable for removing the enclosure from the rack.

Inserting modules

See the [Chapter 6, "Module replacement," on page 37](#) chapter for the following instructions:

- "Inserting a cooling module"
- "Inserting a PSU"
- "Inserting an SBB I/O module"
- "Inserting a DDIC"

Power cord connection

Observe all warnings related to power cords.

Important: When more than one PSU is fitted, connect each PSU to separate and independent supplies to guarantee redundancy.



CAUTION: Always remove the power connections before you remove the PSU from the enclosure.



DANGER: Multiple power cords. The product might be equipped with multiple power cords. To remove all hazardous voltages, disconnect all power cords. (L003)

Grounding checks

The product must only be connected to a power source that has a safety electrical ground connection.



DANGER: If one or more 5U enclosures go into a rack, the importance of the ground connection to the rack increases, because the rack will have a larger "EARTH LEAKAGE CURRENT" ("TOUCH CURRENT").

Examine the ground connection to the rack before the switch-on: an electrical engineer who is qualified for the appropriate local and national standards must do the examination.



DANGER: HIGH LEAKAGE CURRENT. Earth connection essential before connecting supply.

For more information, see [“Electrical safety”](#) on page 5.

System Configurations

For a proper ESS system configuration, review the ESS Deployment Guide and Spectrum Scale RAID Administration Guide.

Data security

Precautions can help preserve data security.

- Power down your host computer and all attached peripheral devices before beginning installation.
- Each enclosure contains up to 84 removable disk drive modules. Disk drives are fragile. Handle them with care, and keep them away from strong magnetic fields.
- All the supplied plug-in modules must be in place for the air to flow correctly around the enclosure and also to complete the internal circuitry. Each row of drive bays must be completely empty or completely full.
- If the enclosure system is used with modules missing for more than a few minutes, the enclosure can overheat, causing power failure and data loss. Such use may also invalidate the warranty.
- If you remove a drive module, replace it immediately. If it is faulty, replace it with a drive module of the same type and capacity.
- Ensure that all disk drives are removed from the enclosure before attempting to manhandle or move the rack installation.
- Do not abandon your backup routines.

Chapter 4. Operation

Before you begin

Before you power up the enclosure make sure that all the modules are firmly seated in their correct bays.

Power on

Instructions for applying power to the enclosure.



CAUTION: Do not operate the enclosure system until the ambient temperature is within the specified operating range. If the drives were recently installed, make sure they have time to adjust to the environmental conditions.

1. Turn off all PSU power switches.
2. Connect the power cables to the PSU(s).
3. Move all PSU power switches to the on position, as shown in the following figure.

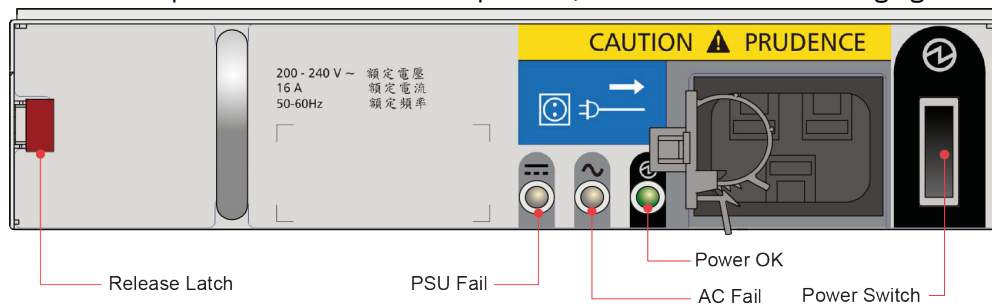

Figure 18. PSU Power Switch and LEDs

4. The system power LED on the ops panel should be lit green and the disk drive motors should start.

Important: If mains power is lost for any reason, the system restarts automatically when power is restored.

Note: For details of the ops panel LEDs and related fault conditions, see "Ops Panel LEDs."

Care should be taken when turning on/off PSUs. The following points should be considered when turning PSUs on/off.

- Remove the AC cord before inserting or removing a PSU.
- Turn off the PSU switch before inserting or removing the AC cord.
- Allow 15 seconds between turning the PSU off and back on again.
- Allow 15 seconds between turning one PSU in the system on and the other PSU off.
- Never turn off a PSU whilst any amber LED is lit on the partner PSU.

Ops panel LEDs

Ops panel LEDs indicate fault and status conditions.

The following table shows the possible conditions for the LEDs.

| Table 3. Ops panel LEDs | |
|----------------------------|---|
| LED | |
| Power On/Standby | Constant green: power is on Constant amber: system is in standby (not operational) |
| Module Fault | Constant or flashing amber: fault |
| Logical Status | Constant or flashing amber: fault |
| Drawer 1 or Drawer 2 Fault | Constant amber: fault in drive, cable or sideplane for specified drawer |

The following figure shows the location of the LEDs.

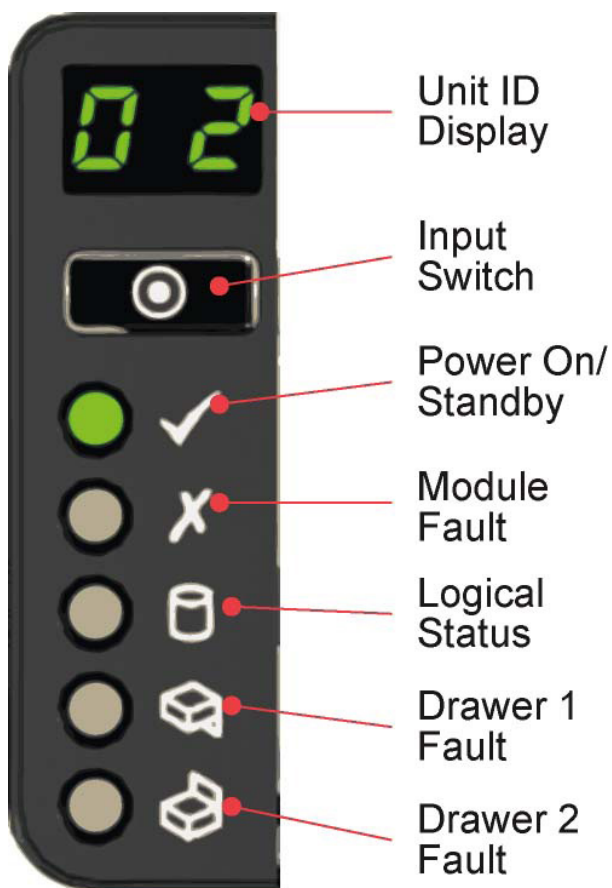

Figure 19. Ops panel LEDs

Unit identification number

How to set the unit identification number

The unit identification number is set from the factory. In the event the unit identification number is not set, the display is set to "00" (flashing). The enclosure continues to power up even when the unit identification number is not set.

To set the unit identification number:

1. Press and hold the Input switch on the ops panel for a period of five seconds. The left digit flashes.
2. Press and release the Input switch to increment the number until the required digit is reached.
3. Press and hold the Input switch for a period of five seconds. The right digit flashes.

4. Press and release the Input switch to increment the number until the required digit is reached.
5. Press and hold the Input switch for a period of five seconds to finish setting the number. Values of “01” to “99” are valid.

Once a unit identification number is set, it is stored in the midplane VPD by the Enclosure Management software and will appear when the enclosure is next powered on. In a situation where the VPD cannot be read, or where there is no enclosure management (no SBB I/O modules, or a single module with management failure) the enclosure will display “00”.

Other uses

The unit identification number can also have the following uses:

- Error codes.
- Unit location identifier. This function sets the display to flash (3 seconds on, 1 second off) until it is stopped, either through SES or by pressing the Input switch.

The unit identification number may be set via other methods. As previously stated, the new setting is applied only after a power cycle. All other functionality remains the same as described previously.

Normal Power down

To prevent potential data corruption and data loss an orderly power down must be performed.

1. Ensure that all applications accessing the storage are either shut down or suspended.
2. Unmount the file systems using NDS and the corresponding vdisks that are part of the recovery group with drives in the enclosure.
3. Shut down I/O server nodes that are accessing the enclosure.
4. Shut down the enclosure by switching off all the power switches of the installed PSUs.

When the enclosure has to be powered down to perform service actions, follow the instructions provided by IBM service.

Locking drawers

A drawer can be locked shut by using a screwdriver with a Torx T20 bit to rotate both anti-tamper locks until the red arrows point away from the center of the enclosure.

The following figure shows the locations of the locks.



Figure 20. Anti-tamper locks

Chapter 5. Troubleshooting

The enclosure system includes a Storage Enclosure Processor (SEP) and associated monitoring and control logic to enable it to diagnose problems within the enclosure's power, cooling, PSU and drive systems.

Initial start-up problems

A number of issues can occur when powering on the enclosure.

Power fault

Ensure that you have wired up the enclosure system correctly and that mains power is present. Call your supplier for replacements if any of the following situations occur:

- Cords are missing or damaged
- Plugs are incorrect
- Cords are too short

Host Computer Does Not Recognize Enclosure

ESS I/O server nodes do not recognize the enclosure.

Ensure that the enclosure is properly connected. See the approved cabling schema in the *Cabling the Elastic Storage Server Appendix of Elastic Storage Server Deploying the Elastic Storage Server Guide*.

See subsection *Disk Enclosure and HBA cabling* in chapter *Setting up IBM Spectrum Scale RAID* in the *Elastic Storage Server Spectrum Scale RAID Administration Guide*.

LEDs

LED colors are used consistently throughout the enclosure and its components to indicate status

Green

Good or positive indication

Flashing green or amber

Non-critical condition

Amber

Fault

Note: When the enclosure is powered on, all LEDs light up for a short period to ensure that they are working. This condition does not indicate a fault unless the LEDs remain lit after a few seconds.

PSU LEDs

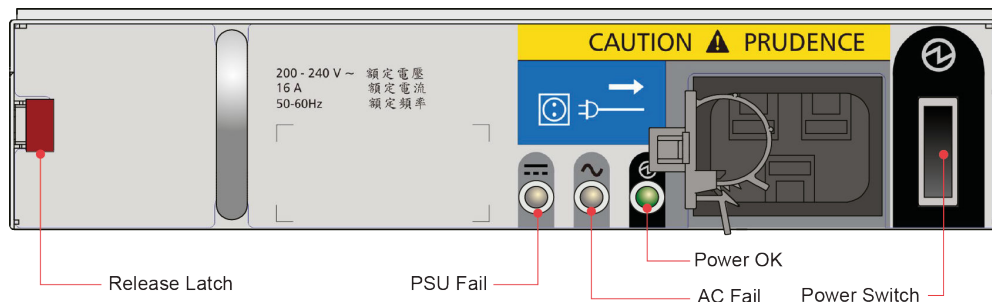

Figure 21. PSU LEDs

| PSU Fail (Amber) | AC Missing (Amber) | Power (Green) | Status |
|------------------|--------------------|---------------|--|
| Off | Off | Off | No AC power to either PSU. |
| On | On | Off | PSU present, but not supplying power or PSU alert state (usually due to critical temperature). |
| Off | Off | On | Main AC present, switch on. This PSU is providing power. |
| Off | Off | Flashing | AC power present, PSU in standby (other PSU is providing power). |
| Flashing | Flashing | Off | PSU firmware download |
| Off | On | Off | AC power missing, PSU in standby (other PSU is providing power). |
| On | On | On | Enclosure management software has lost communication with the PSU. |
| On | - | Off | PSU has failed. Follow the procedure in "Replacing a Power Supply Unit (PSU)." |

Cooling module LEDs

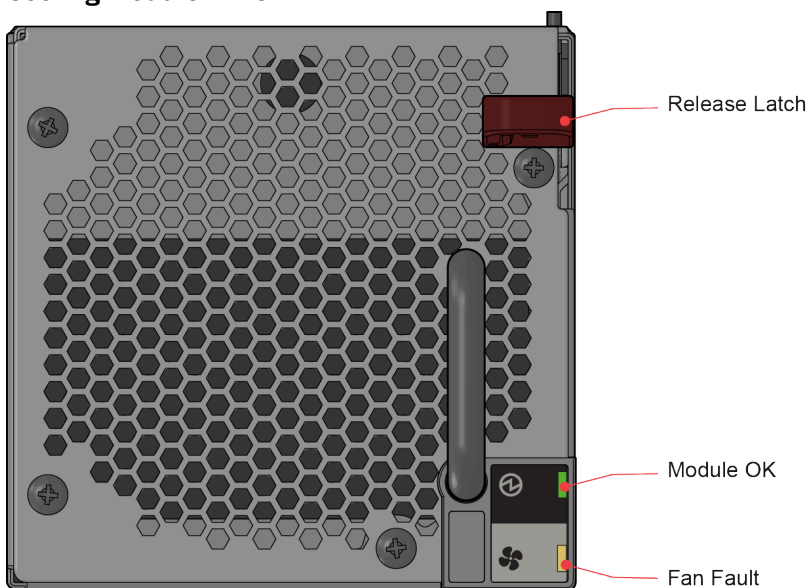

Figure 22. Cooling module LEDs

| LED | Description |
|---------------|---|
| Module OK | Constant green indicates that the fan is working correctly. Off means the fan has failed. Follow the procedure in "Replacing a Cooling Module." |
| Battery Fault | Not currently used. |
| Fan Fault | Amber indicates that a fan has failed. Follow the procedure in "Replacing a Cooling Module." |

Operator's panel LEDs

The operator's (ops) panel displays the aggregated status of all the modules, as shown in the following figure.

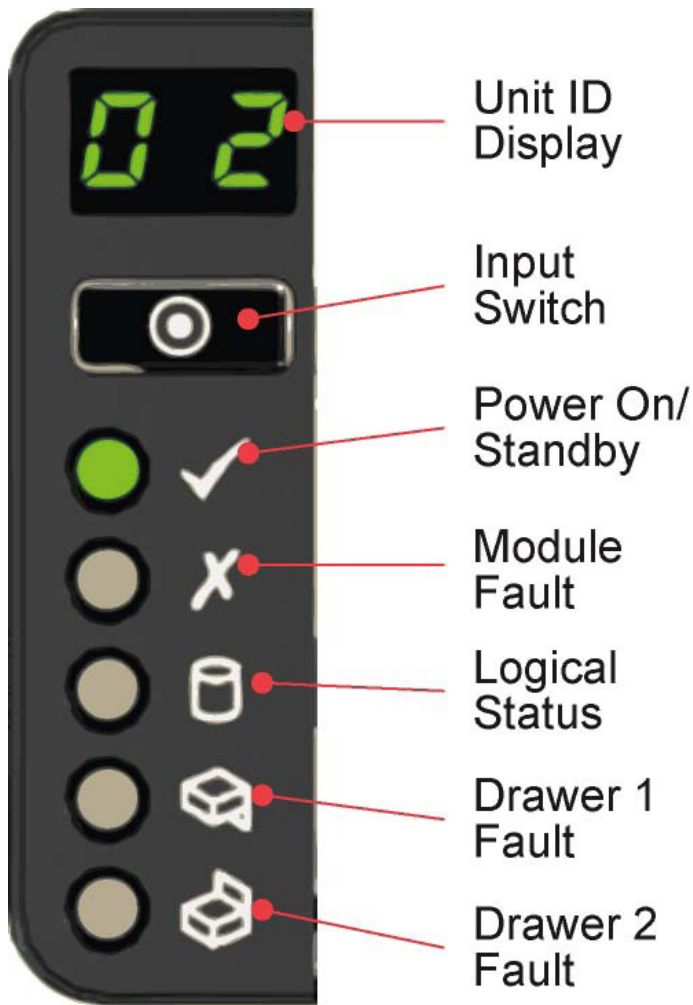

Figure 23. Operator's panel LEDs

| Display/LED | Description |
|-----------------------------|---|
| Unit Identification Display | Usually shows the identification number for the enclosure, but can be used for other purposes. |
| Power On/Standby LED | Amber if the system is in standby. Green if the system has full power. |
| Module Fault LED | Amber indicates a fault in a PSU, cooling module or SBB I/O module. Check the drawer LEDs to see if a drive fault is indicated (see Drawer LEDs) |
| Logical Status LED | Amber indicates a fault from something other than enclosure management usually a disk (drive fault, or Spectrum scale RAID). Check the drawer LEDs to see if a drive fault is indicated (see Drawer LEDs). |

| Display/LED | Description |
|--------------------|---|
| Drawer 1 Fault LED | Amber if there is a drive, cable, or sideplane fault in drawer 1. Open the drawer and check the disk drive LEDs for faults. |
| Drawer 2 Fault LED | Amber if there is a drive, cable, or sideplane fault in drawer 2. Open the drawer and check the disk drive LEDs for faults. |

Drawer LEDs

The following figure shows the names and locations of the disk drawer LEDs.

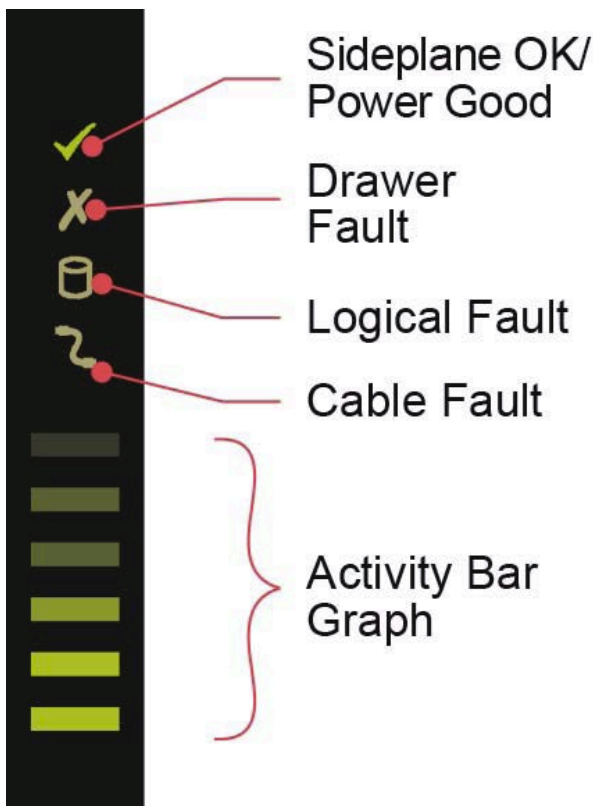

Figure 24. Drawer LEDs (left sideplane only)

| LED | Description |
|-------------------------|---|
| Sideplane OK/Power Good | Green if the sideplane card is working and there are no power problems. |
| Drawer Fault | Amber if a drawer component has failed. If it is a drive that has failed, an amber LED lights up on the failed drive; follow the procedure in "Replacing a Disk Drive in Carrier (DDIC)." If the drives are functioning correctly, contact your storage vendor to identify the failure. |
| Logical Fault | Amber if there is a drive fault. |
| Cable Fault | Amber if the cabling between the drawer and the back of the enclosure has failed. Contact support to resolve the problem. |

Table 7. Drawer LED descriptions (continued)

| LED | Description |
|--------------------|---|
| Activity Bar Graph | Shows the amount of data I/O from zero segments lit (no I/O) to all six segments lit (maximum I/O). |

Disk drive in carrier (DDIC) LED

Each disk drive has a single amber drive fault LED as shown in the following figure. When lit, service action is required for the drive. See *Elastic Storage Server Spectrum Scale RAID Administration Guide* for servicing and replacing the drive. Do not remove or replace a drive without following the proper procedure stated in *Elastic Storage Server Spectrum Scale RAID Administration Guide*.

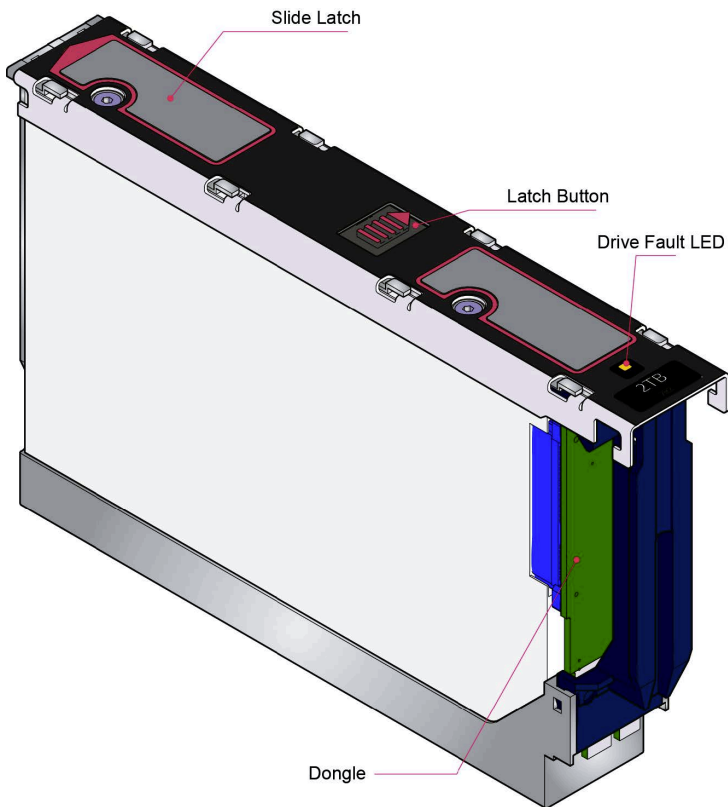

Figure 25. Drive Fault LED

SBB I/O Module LEDs

The following figure shows the LEDs on the 6 Gb/s SAS EBOD SBB I/O module.

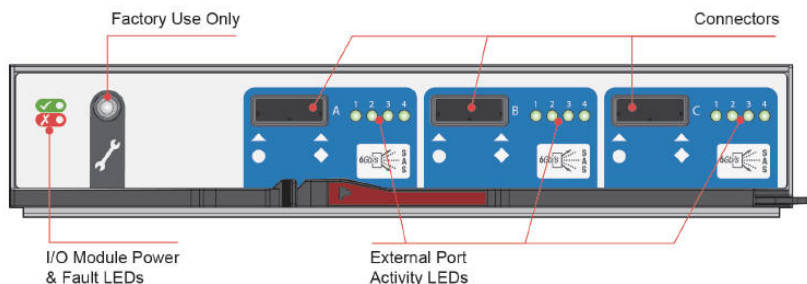

Figure 26. SBB I/O module LEDs

Table 8. 6Gb/s SAS EBOD I/O Module LED Descriptions

| LED | Description |
|-----------------------------|--|
| I/O Module OK | Constant green if the I/O module is operating correctly. Flashing green indicates an I/O module VPD error. |
| I/O Module Fault | Constant amber if the I/O module is faulty. For replacement procedure see “Replacing an SBB I/O module” on page 45. |
| External Host Port Activity | Constant green indicates that there is a host port connection but no activity. Flashing green indicates that there is a host port connection, and data is being transferred. |

Thermal sensors

Thermal sensors throughout the enclosure and its components monitor the thermal health of the storage system. Exceeding the limits of critical values will cause the Over-temperature alarm to occur.

Troubleshooting

The following sections describe problems that can occur with your storage systems and some possible solutions. The module fault LED on the ops panel displays a solid amber color to indicate a fault. All alarms will also be reported by SES. See *Elastic Storage Server Spectrum Scale RAID Administration Guide* and the *Maintenance Procedures* section in *Elastic Storage Server Problem Determination Guide*.

Table 9. Alarm Conditions

| Status | Severity |
|--|--------------------------------------|
| PSU alert – loss of DC power from a single PSU | Fault: loss of redundancy |
| Cooling module fan failure | Fault: loss of redundancy |
| SBB I/O module detected PSU fault | Fault |
| PSU removed | Configuration error |
| Enclosure configuration error (VPD) | Fault: critical |
| Low temperature warning | Warning |
| High temperature warning | Warning |
| Over-temperature alarm | Fault: critical |
| Under-temperature alarm | Fault: critical |
| I2C bus failure | Fault: loss of redundancy |
| Ops panel communication error (I2C) | Fault: critical |
| SBB I/O module fault | Fault – critical |
| SBB I/O module removed | Warning |
| Drive power control fault | Warning; no loss of drive power |
| Drive power control fault | Fault: critical; loss of drive power |
| Insufficient power available | Warning |

For information on how to remove and replace a module, see "Module Replacement."

Thermal monitoring and control

The system uses extensive thermal monitoring and takes a number of actions to ensure that component temperatures are kept low and also to minimize acoustic noise. Air flows from the front to the rear of the enclosure.

Symptom

If the ambient air is below 77 °F (25 °C) and the fans are observed to increase in speed, then some restriction on airflow may be causing additional internal temperature rise.

Note: This is not a fault condition.

Cause

The first stage in the thermal control process is for the fans to automatically increase in speed when a thermal threshold is reached. This may be caused by higher ambient temperatures in the local environment and may be perfectly normal.

Note: This threshold changes according to the number of drives and power supplies fitted.

Action

1. Check the installation for any airflow restrictions at either the front or rear of the enclosure. A minimum gap of 25mm at the front and 50mm at the rear is recommended.
2. Check for restrictions due to dust buildup. Clean as appropriate.
3. Check for excessive re-circulation of heated air from rear to the front. Use of the enclosure in a fully enclosed rack is not recommended.
4. Check that all blank modules are in place.
5. Reduce the ambient temperature.

Thermal alarm

Symptom

Ops panel module fault LED is amber.

Fan fail LED is lit on one or more cooling modules.

Cause

The internal temperature has exceeded a preset threshold.

Action

1. Check that the local ambient environment temperature is below the specification (see "Temperature and Humidity").
2. Check the installation for any airflow restrictions at either the front or rear of the enclosure. A minimum gap of 1 in. (25 mm) at the front and 2 in. (50 mm) at the rear is recommended.
3. Check for restrictions due to dust buildup. Clean as appropriate.
4. Check for excessive recirculation of heated air from rear to the front. Use of the enclosure in a fully enclosed rack is not recommended.
5. If possible shut down the enclosure and investigate the problem before continuing.

Dealing with hardware faults

Ensure that you have obtained a replacement module of the same type before removing any faulty module.

Important: Only replace a module when it has been instructed by IBM service. Unplanned replacement of modules can lead to loss or access of data. When a module is removed for service, replace it immediately. If the system is used with any modules missing for more than a few seconds, the enclosure can begin to overheat, causing loss or access of data. This action invalidates the warranty.

Important: Observe all conventional ESD precautions when handling modules and components. Avoid contact with midplane components and module connectors.

Firmware Updates

Use Spectrum Scale RAID to update firmware. For updating enclosure firmware, see the *Elastic Storage Server Spectrum Scale RAID Administration Guide*.

Chapter 6. Module replacement

Overview

Observe all required precautions when replacing modules.

Important: Always have available a replacement or blank module before removing the old module. When you replace a module, you must never leave an empty bay in the rear of the enclosure.

ESD Precautions

Important: Fit and check a suitable anti-static wrist or ankle strap and observe all conventional ESD precautions when handling plug-in modules and components. Avoid contact with midplane and sideplane components, and with module connectors.

Continuous operation during replacement

Your hardware or software enclosure management application determines the capability of replacing a failed disk without loss of access to any file system on the enclosure. Enclosure access and use during this period is uninterrupted. If an enclosure contains two PSUs, one of them can maintain power to the system while the other is replaced.

Field replaceable units (FRUs)

The following components can be hot-swapped by the user in the field without removing the enclosure from its rack:

Table 10. Part numbers of Field replaceable units

| Part # | Substitute Part | Part Desc |
|----------|-----------------|-----------------------|
| 001JC685 | | SIDEPLANE - RIGHTSIDE |
| 001GY676 | | EXPANDER - LEFTSIDE |
| 001YK759 | | CONTROLLER |
| 001ML986 | | CONTROLLER |
| 001YK785 | | CHASSIS |
| 001YK760 | 001YK785 | CHASSIS |
| 001JC684 | 001YK760 | CHASSIS |
| 001GY674 | | 5U RAIL |
| 000RP210 | | 42DISKPACK |
| 000J1896 | | 3M CABLE |
| 001KL631 | | 2.5M CABLE |

The drawer sideplanes can be hot-swapped in the field. Replacement of the sideplanes requires a special tool and should be carried out by service personnel only. Refer to the IBM ESS Expansion Hot Swap Side Card - Quick Installation Guide for full instructions.

Customer-replaceable units (CRUs)

| Table 11. Part numbers of Customer-replaceable units | | |
|--|-----------------|-----------|
| Part # | Substitute Part | Part Desc |
| 001GY673 | | PWR CABLE |
| 001JC682 | | FAN |
| 001ML987 | | EXPANDER |
| 001JC683 | | EBOD 6G |
| 000LY451 | | 800GB SSD |
| | | 2800W PSU |
| 001JC681 | 002PX823 | 2800W PSU |
| 000LY450 | | 8TB HDD |
| 000LY449 | | 4TB HDD |
| 001LU840 | | 14TB HDD |
| 000LY453 | | 10TB HDD |

General procedures

General procedures include opening and closing drive drawers.

Opening a drawer

1. Make sure the anti-tamper locks are not engaged. The red arrows on the locks will point inwards if the locks are disengaged (see the following figure). Unlock them if necessary by rotating them counterclockwise using a screwdriver with a Torx T20 bit.

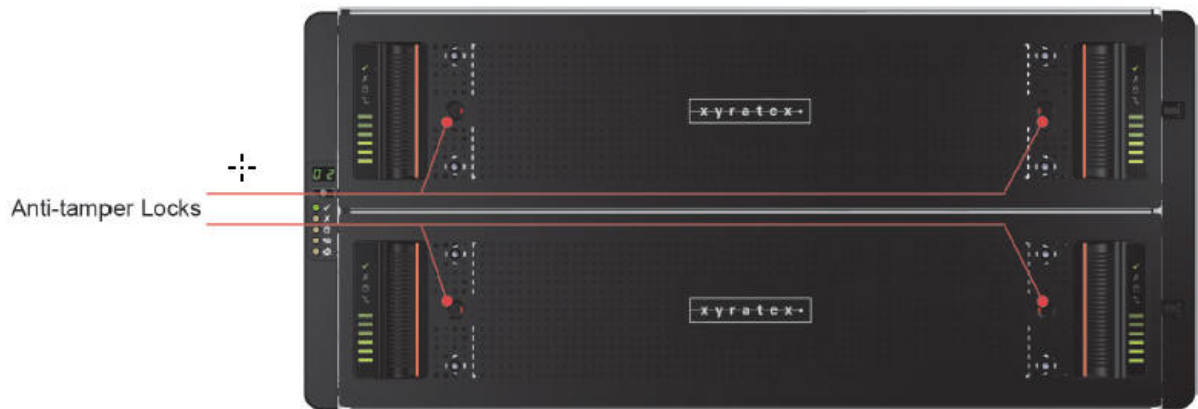

Figure 27. Anti-tamper locks (shown disengaged)

2. Push the drawer latches inward and hold them (see the following figure).



Figure 28. Opening the bottom drawer

3. Pull the drawer all the way out until it locks open.

Important: The drawer must not be left open for more than two minutes while the enclosure is powered.

Closing a drawer

1. Press and hold both of the black latches on the sides of the drawer (see the following figure).

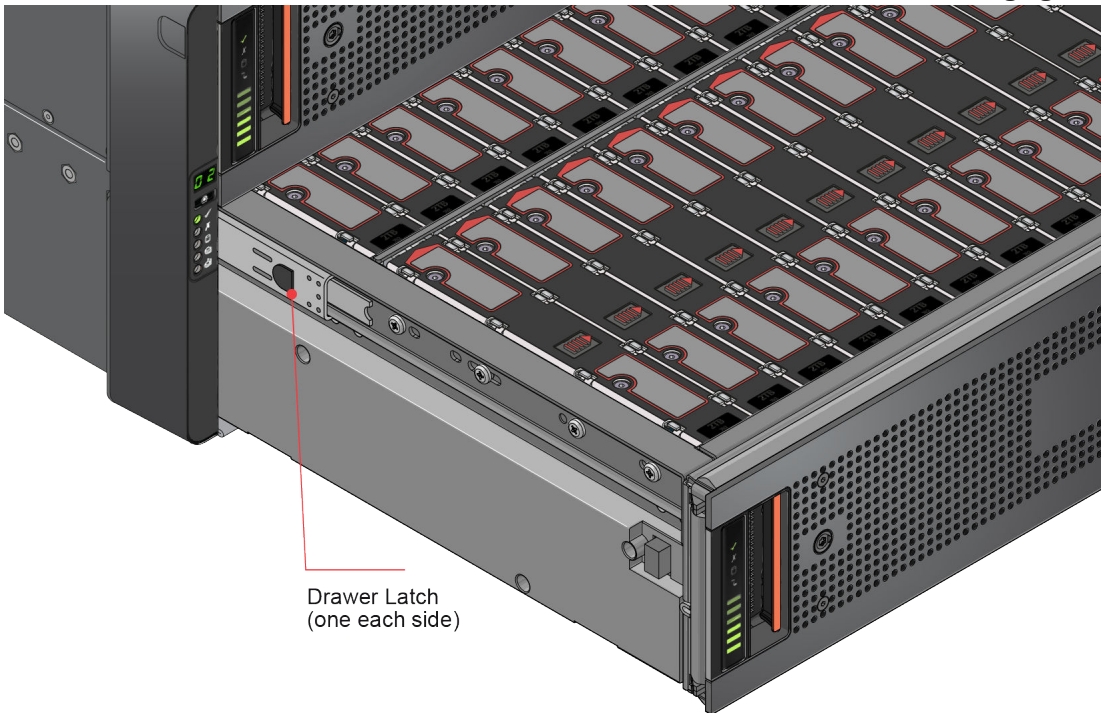

Figure 29. Drawer latch

2. Push the drawer in slightly.

3. Release the black latches and check they have returned to their original position.
4. Push the drawer all the way back into the enclosure, making sure it clicks home.

Replacing a disk drive in carrier (DDIC)

For monitoring and replacing failed drives, see *Elastic Storage Server Spectrum Scale RAID Administration Guide*. Two steps are required; removing the existing drive, and replacing it with a new one.

Removing a DDIC

Note: Remove a drive only if a replacement is available. Closing the drawer with one or more drives removed can cause cooling problems.

1. Identify which drawer contains the drive to be replaced. If the drive number is known, you can use the plan in the following figure. If the drive failed, the drive fault LED is lit amber on the relevant drawer.

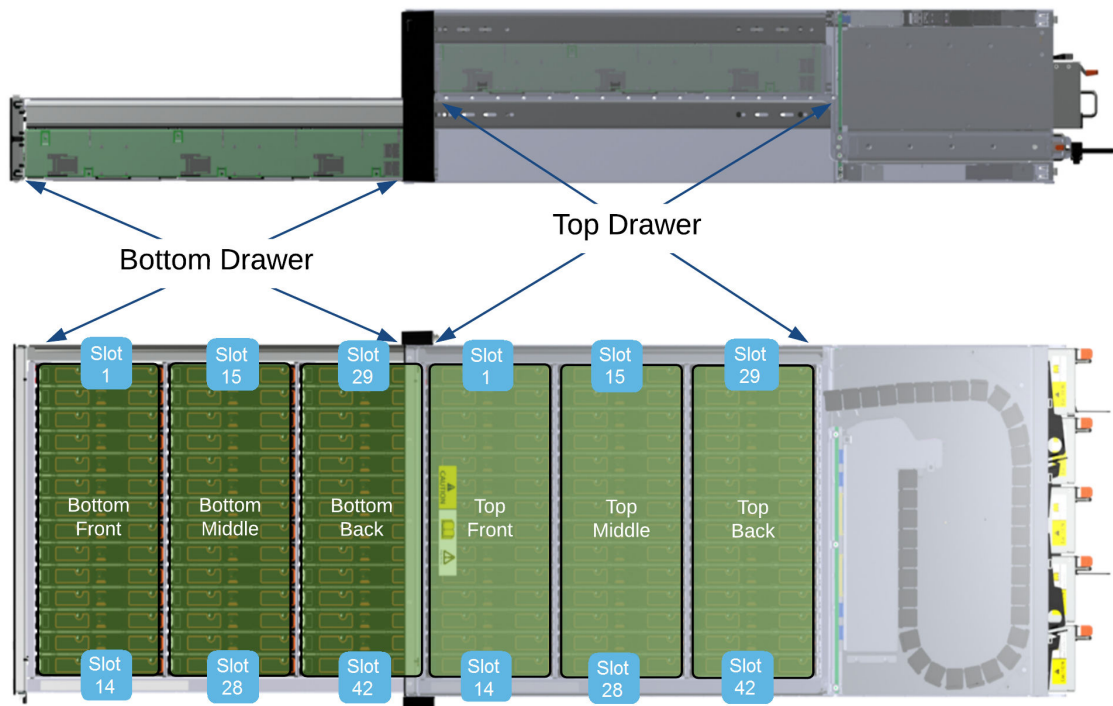

Figure 30. Drive location plan

Note: Some enclosure management features identify drive bays using a 1-based count (1–84) while others use a 0-based count (0–83). For more information, contact the storage provider.

2. Open the relevant drawer using the instructions in "Opening a Drawer."
3. Locate the drive to be replaced, either by using the drive plan in the previous figure or by looking for the amber LED on the drive that indicates a fault.
4. Push the drive carrier latch in the direction shown in the following figure to unlock the drive.

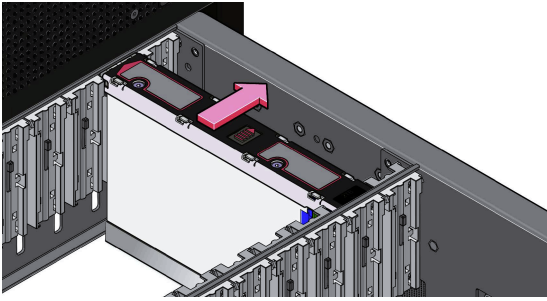

Figure 31. Removing a DDIC

5. Pull the drive upward and out of the drawer.

Important: If you are not going to replace the drive immediately, close the drawer (see "Closing a Drawer") so that correct airflow and cooling are maintained in the enclosure.

Inserting a DDIC

Important: Failed drives must be replaced with approved drives.

1. If the relevant drawer is not already open, open it using the instructions in "Opening a Drawer."
2. Lower the DDIC into the slot, with the drive capacity label facing towards you, as shown in the following figure.

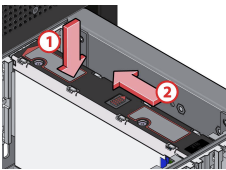

Figure 32. Installing a DDIC

3. Push the DDIC downwards and hold it down while sliding the drive carrier plate in the direction shown in the previous figure. This action locks the drive in place.
4. Check that the release latch has returned to its locked position, as shown in the following figure.

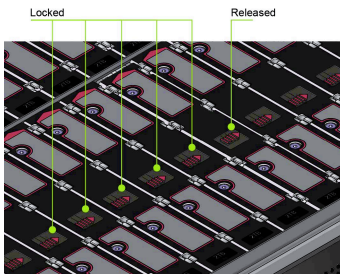

Figure 33. Latch position of a correctly inserted drive

5. Close the drawer using the instructions in section Closing a Drawer.

Note: The drawers must be populated with drives in whole rows at a time (there are 3 rows of 14 drives per drawer). Observe the following rules:

- The minimum number of drives in an enclosure is 14.
- The number of rows must not differ by more than 1 between top and bottom drawers.
- The rows must be populated from the front to the rear of the enclosure.

Note: The enclosures must be fully populated in the ESS application.

Replacing a cooling module

The process involves removing the existing module and inserting a new one. Before hot-swapping a cooling module, ensure the other cooling module has the “Power OK” LED lit.

Removing a cooling module

Important: Before you remove a module, ensure you have a replacement module to insert.

1. Identify the cooling module to be removed. If the module has failed, the fan fault LED will display an amber color, as shown in the following figure.

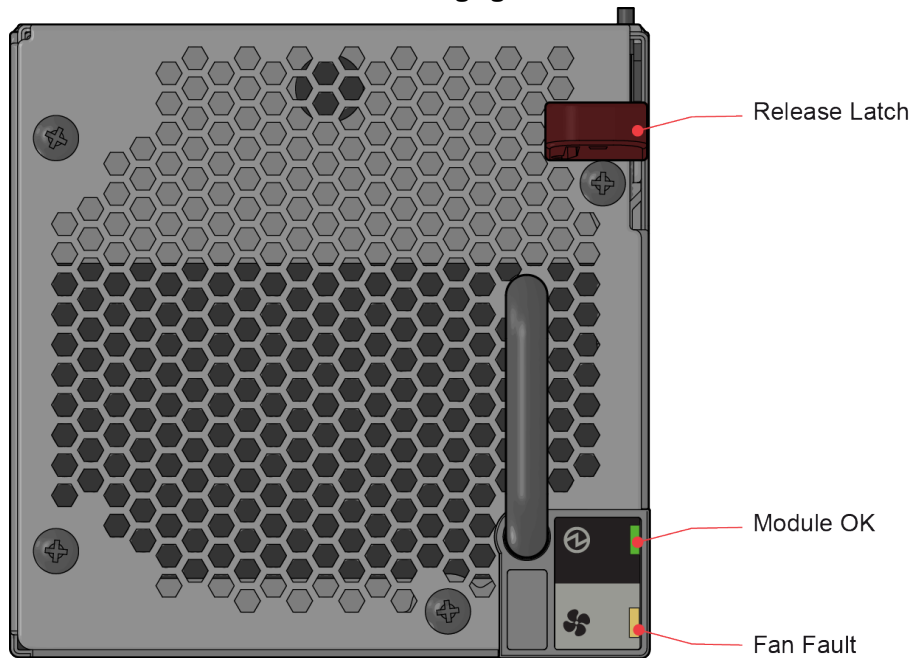

Figure 34. Cooling module LEDs

2. As shown in the following two figures, push down and hold the red release latch (1) and pull the module out by its handle (2).

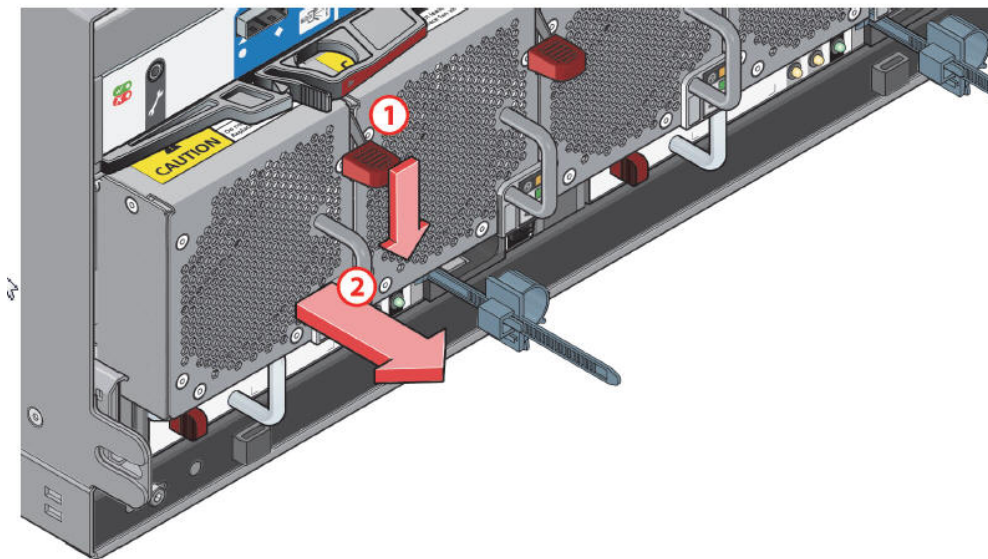

Figure 35. Removing a Cooling Module (1)

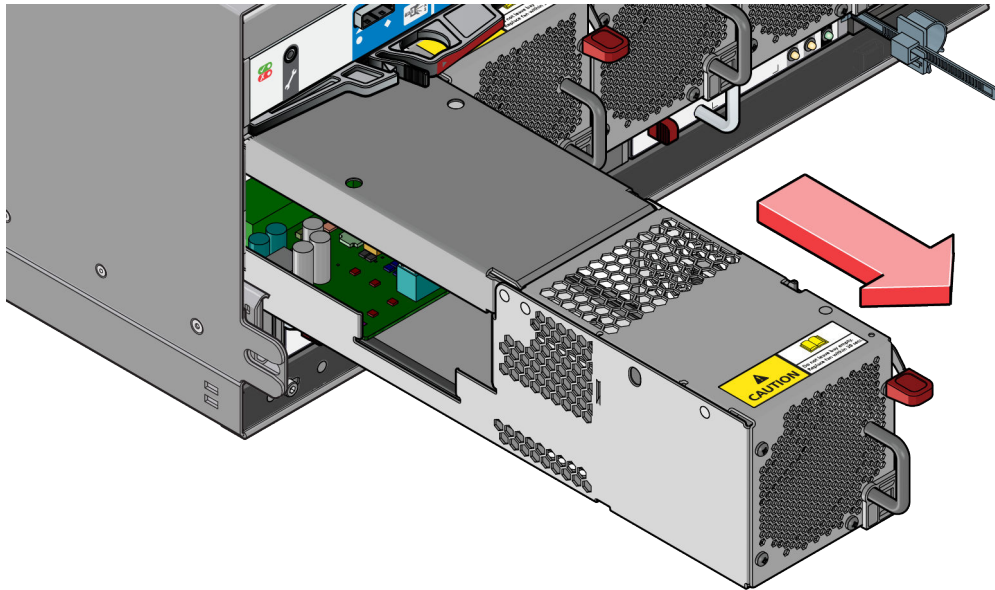

Figure 36. Removing a Cooling Module (2)

Important: The cooling module bay must not be empty for more than two minutes while the enclosure is powered up.

Inserting a cooling module

1. Rotate the cooling module so that the black release latch and handle are on the right side.
2. Slide the cooling module into its slot until the latch clicks home. The enclosure automatically detects and uses the new unit.

Replacing a power supply unit (PSU)

The process involves removing the existing module and inserting a new one.

Removing a PSU

Important: Before removing a PSU, make sure you have a replacement module to insert.

1. Identify the PSU to be removed by using appropriate fault reporting software.
2. Ensure the other PSU has the “Power OK” LED lit.
3. Turn off the PSU to be removed.
4. Disconnect the AC power cord.
5. As shown in the following two figures, push the red release latch to the right and hold it (1), then pull the module out by its handle (2).

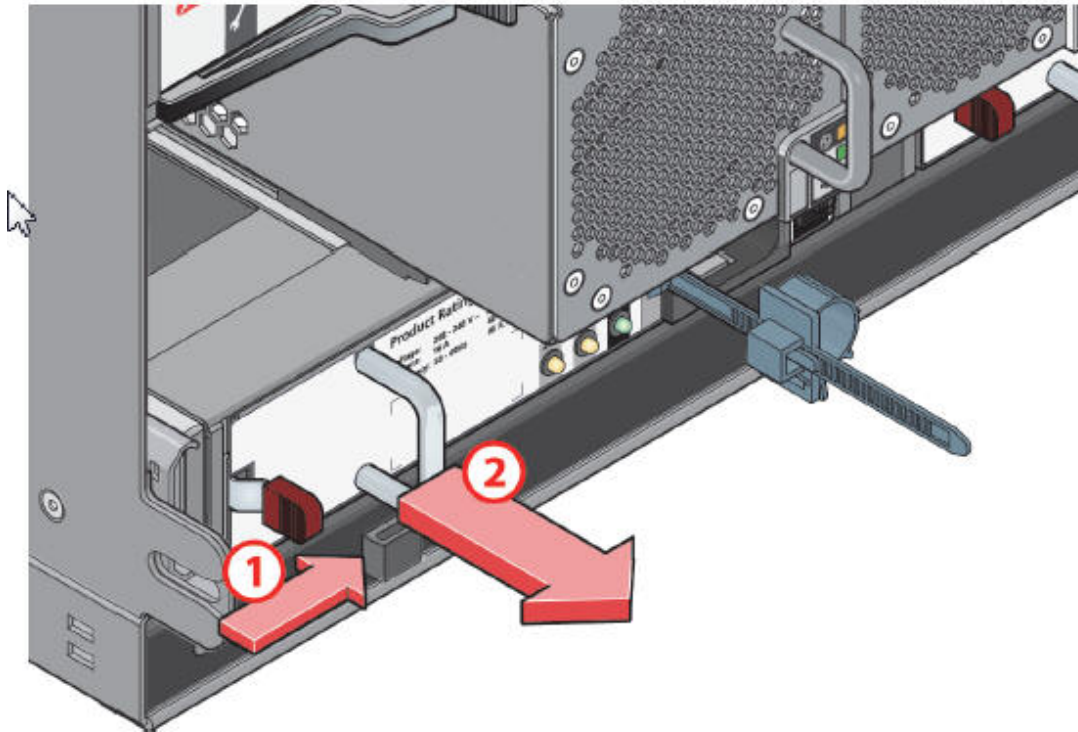

Figure 37. Removing a PSU module (1)

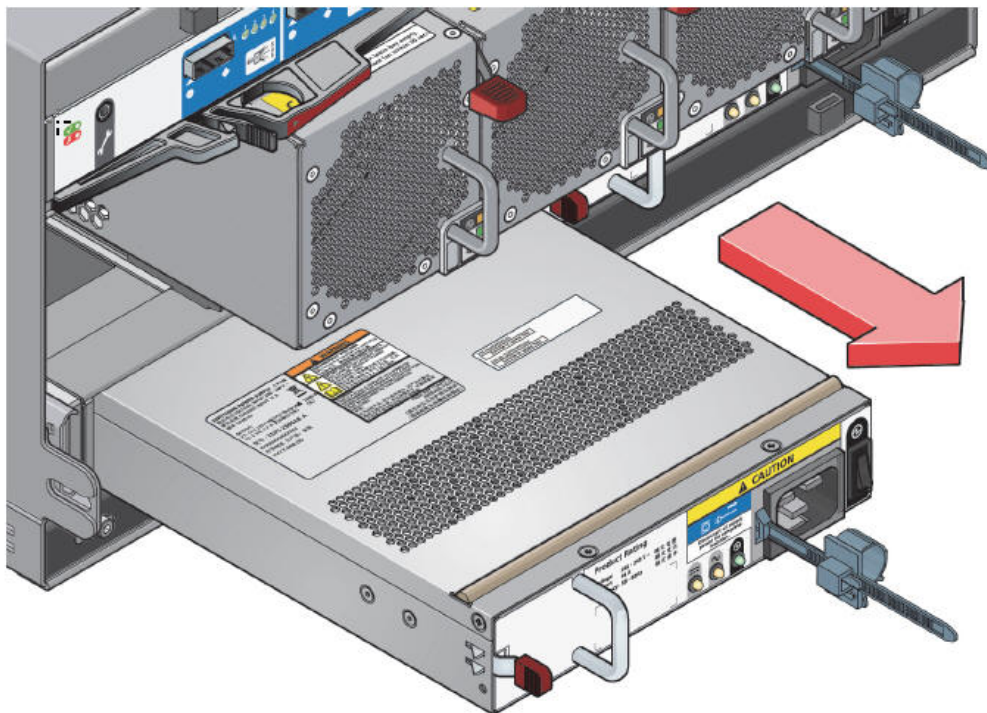

Figure 38. Removing a PSU Module (2)

Important: The PSU module bay must not be empty for more than two minutes while the enclosure is powered up.

Inserting a PSU

1. Ensure the PSU is switched off.

2. Rotate the PSU so that the red release latch and handle are on the left side.
3. Slide the PSU into its slot until the latch clicks home.
4. Connect the AC power cord.
5. Turn on the PSU power switch.
6. Wait for the "Power OK" LED on the newly inserted PSU to turn on. If the "Power OK" LED does not turn on, the PSU was not inserted properly or is defective. Otherwise, the enclosure will automatically detect the new unit.

Replacing an SBB I/O module

The process involves removing the existing module and inserting a new one.

Important: Before removing an SBB I/O module, make sure you have a replacement module to insert.

Removing an SBB I/O module

1. Identify the SBB I/O module to be removed. If the module failed, the fault LED is lit in an amber color.

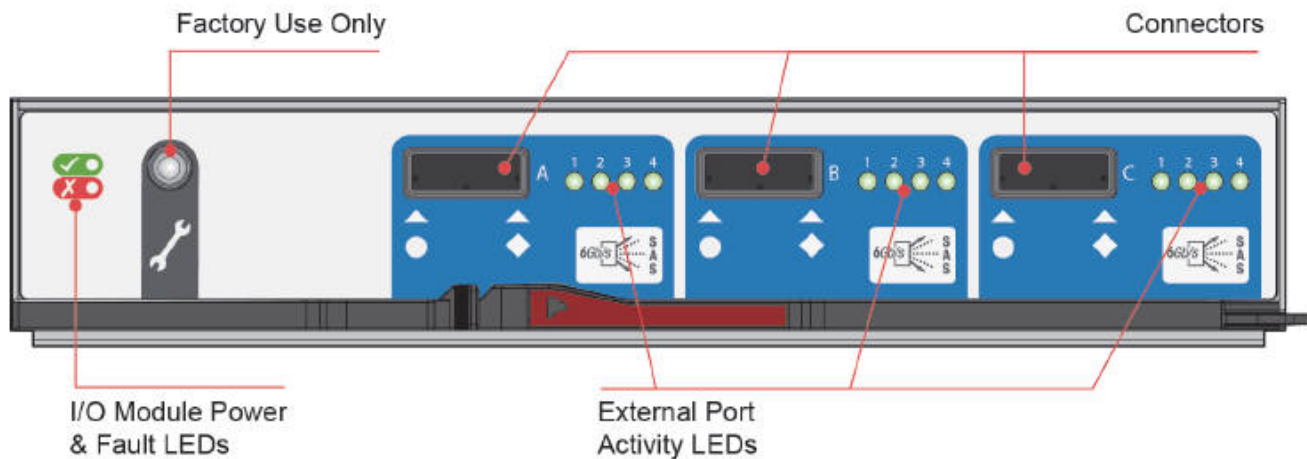

Figure 39. SBB I/O module LEDs

2. Make a note of the locations of the cables before removing them from the I/O module.
3. As shown in the following two figures, pinch the latch on the module and pull the handle towards you (1). This action levers the module out of its connector on the midplane.

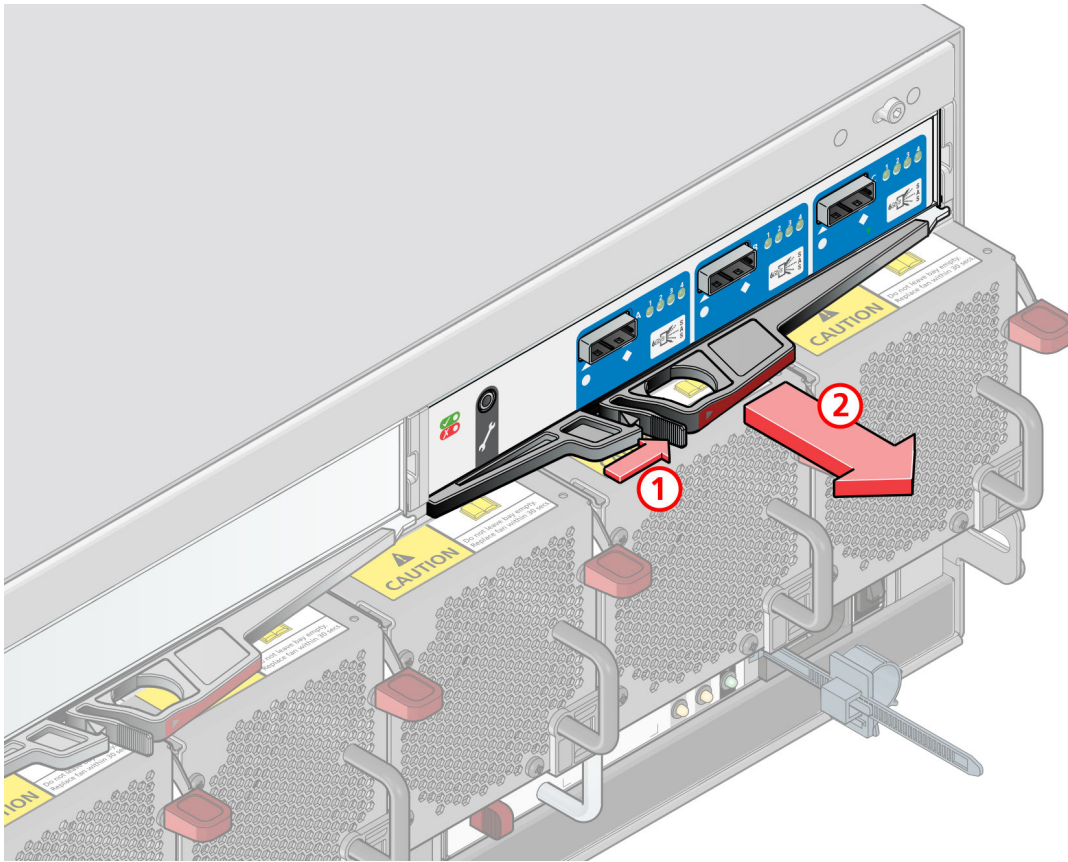

Figure 40. Removing a module (1). (6Gb/s SAS EBOD module shown)

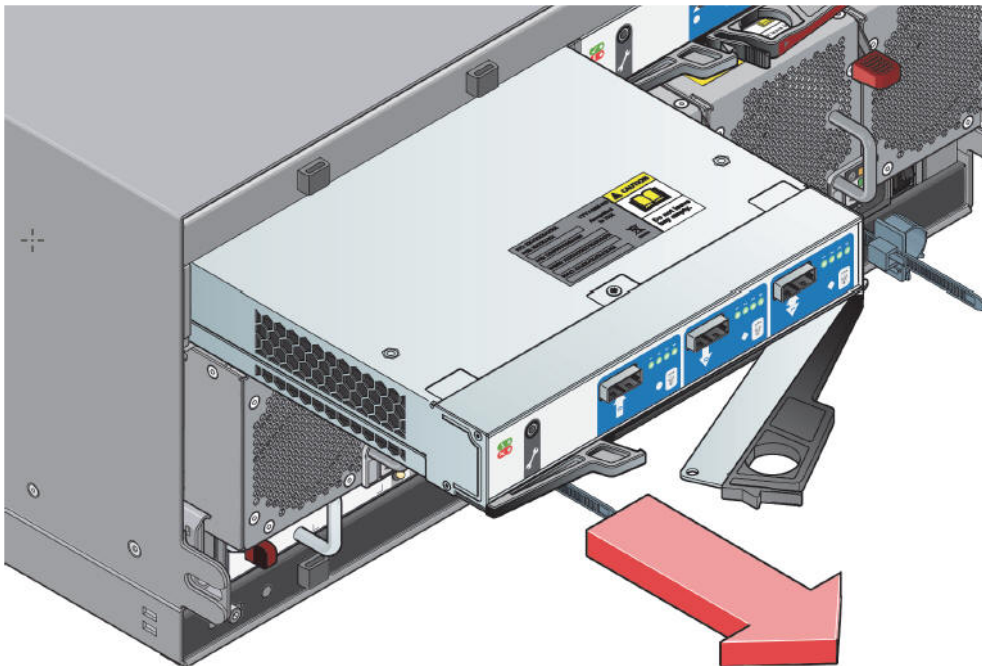

Figure 41. Removing an I/O module (2)

4. Pull the module out of the enclosure (2).

Important: The SBB I/O module bay must not be empty for more than two minutes while the enclosure is powered.

Inserting an SBB I/O module

1. Rotate the SBB I/O module so that the release latch is at the bottom.
2. Open the release latch and rotate it to its most open position, as shown in the previous figure.
3. Slide the I/O module into its slot until it will go no farther and the handle has started to close.
4. Close the latch until it clicks home. This levers the module home into its connector on the midplane. The enclosure automatically detects the new unit.
5. Connect the cables to the new module. If necessary, refer to the note you made before you removed the cables from the defective I/O module.

Appendix A. Technical specifications

Dimensions

The table shows the dimensions of the enclosure.

| <i>Table 12. Enclosure dimensions</i> | | |
|---|---------------|--------------------|
| Dimension | Inches | Millimeters |
| Height (enclosure, overall) | 8.75 | 222.3 |
| Width across mounting flange | 19 | 482.6 |
| Depth from rear of front flanges to rear extremity of chassis | 36 | 915 |

Weights

The table shows the weight of the components. All weights are approximate.

| <i>Table 13. Component weights</i> | | |
|------------------------------------|---------------|------------------|
| Component | Pounds | Kilograms |
| Fully populated enclosure | 298 | 135 |
| Drive carrier | 1.8 | 0.8 |
| PSU | 6 | 2.7 |
| Cooling module | 3 | 1.4 |

Components (fully populated)

The table shows the components that populate the enclosure.

| <i>Table 14. Components</i> | |
|---------------------------------|-----------------|
| Component | Quantity |
| Drawers | 2 |
| Disk Drives In Carriers (DDICs) | 84 |
| SBB I/O module | 2 |
| PSUs | 2 |
| Cooling modules | 5 |

Thermal

The table shows the specifications for the thermal sensors.

| Specification | Quantity |
|-------------------------------|--|
| Thermal sensors | 2 per sideplane (2 sideplanes per drawer) |
| | 2 per drawer baseplane (front) |
| | 1 per drawer baseplane (middle/rear) |
| | 2 per power supply |
| | Number in SBB I/O module is dependent on module type |
| Airflow with all fans running | 120 liters/second maximum |

Temperature and humidity

The table shows the temperature and humidity limits for the enclosure.

| Factor | Operating | Non-operating |
|-------------------|-------------------------------|-------------------------------|
| Temperature range | 41°F (5°C) to 95°F (35°C) | -40°F (-40°C) to 158°F (70°C) |
| Relative humidity | 20%rh to 80%rh non-condensing | 5%rh to 100%rh non-condensing |
| Maximum wet bulb | 82°F (28°C) | 84°F (29°C) |

Cooling modules

Each of the five cooling modules contains 2 stacked fans: 80mm x 80mm x 38mm.

SBB I/O module

A separate specification exists for each SBB I/O module.

Power supply unit (PSU)

The table shows the specifications of the PSU.

| Category | Value |
|---------------------|--|
| Output power | 2814W maximum continuous output power at high line voltage |
| Voltage | +12V at 233A (2796W total output power) |
| | +5V standby voltage at 2.7A |
| Input voltage range | 200 to 240VAC |
| Input frequency | 50 to 60Hz |

| <i>Table 17. PSU specifications (continued)</i> | |
|---|---|
| Category | Value |
| Power factor correction | >0.95 @ 100% load |
| Efficiency | 87% at 20% load |
| | 90% at 50% load |
| | 87% at 100% load |
| Holdup time | 5ms from ACOKn high to rails out of regulation (see SBB v2 specification) |
| Main power inlet connector | IEC60320 C20 with cable retention |
| Weight | 3kg |

Supported drives

The table shows the supported drives for the enclosure.

| <i>Table 18. Supported drives for enclosure</i> | |
|---|--|
| Type | Description |
| Hard disk drives (HDD) | 4TB Enterprise HDD (IBM Part number: 00LY449) |
| | 8TB Enterprise HDD (IBM Part number: 00LY450) |
| | 10TB Enterprise HDD (IBM Part number: 00LY453) |
| Solid State Drives (SSD) | 800GB SDD (IBM Part number: 00LY451) |

Shock and vibration tolerance

The table shows the shock tolerance for the enclosure.

| <i>Table 19. Shock and vibration tolerance</i> | |
|--|---|
| Type | Tolerance |
| Operational vibration | 0.21g RMS, 5 to 500Hz random with <=10% throughput loss |
| Operational shock | 5g 10ms ½sine |
| Relocation vibration (non-operational) | 0.3g, 2 to 200 to 2Hz swept sine |
| Non-operational vibration | 1.04g RMS, 2 to 200Hz random |
| Non-operational shock | 20g 10ms ½sine |

Appendix B. Standards and regulations

The appliance is designed to comply with the standards and regulations enumerated in sections below. This compliance includes any sample units.

EMC qualification

Model 084 meets a number of EMC standards.

Model 084 carries EMC approval for the following territories:

- Australia/New Zealand
- Canada
- European Union
- United States of America
- Taiwan (CNS 13438-2006)
- Japan
- South Korea
- EAC region

Conducted emission standards

Model 084 complies with the following EMC conducted emission standards:

- EN 55022:2006 including A1:2007 / CISPR 22-Class A
- EN 55032:2012/AC: 2013/CISPR32:2015-Class A
- KN32:2015 and KN35:2015
- United States CFR47 Part 15: Radio Frequency Devices, Subpart B: Unintentional Radiators, Class A

Class A labeling is used.

Radiated emission standards

Model 084 complies with the following EMC radiated emission standards:

- EN 55022:2006 including A1:2007 / CISPR 22-Class A
- EN 55032:2012/AC: 2013/CISPR32:2015-Class A
- KN32:2015
- Individual shelves and towers comply with United States CFR47 Part 15: Radio Frequency Devices, Subpart B: Unintentional Radiators, Class A

Class A labeling is used.

Harmonics

EMC harmonics are in accordance with EN 61000-3-2:2014.

Flicker

EMC flicker is in accordance with EN 61000-3-3:2013.

Immunity standards

EMC immunity is in accordance with the following standards:

- European standard EN55024:2010/CISPR24:2010
- KN35:2015

Safety

Model 084 meets a number of safety standards.

Model 084 is approved as safe for use in the following territories:

- Canada
- European Union
- United States of America

Product Type Safety approval: UL, cUL and CE.

The enclosure meets the requirements of the latest editions of the following standards:

- EN 60950-1
- IEC 60950-1
- UL 60950-1
- CAN/CSA-C22.2 No. 60950-1-07

A CB report to the latest applicable edition of the standard IEC 60950-1 is available for the power and cooling module and product type. The CB report has also been written with consideration to the latest applicable edition of the standard EN 60950-1, and include the national differences for all countries in the CB scheme.

The Model 084 enclosure meets the fire enclosure standards set out in the latest applicable edition of UL 60950-1.

Environmental and Recycling

RoHS and JIG A

The IBM ESS expansion Model 084 enclosure is manufactured from RoHS compliant materials and components, in accordance with EU Directives 2002/95/EC and 2011/65/EU.

Additionally, this enclosure does not contain any substances or materials listed in Annex A of Joint Industry Guide JIG-101, Material Composition Declaration for Electronic Products (also known as 'JIG A Materials').

These restricted substances include:

- Lead (lead-free solder is used throughout).
- Mercury.
- Cadmium.
- Hexavalent chromium.
- Polybrominated biphenyls (PBB).
- Polybrominated diphenyl ethers (PBDE).

WEEE

At the end of the product's life, all scrap and waste electrical and electronic equipment should be recycled in accordance with national regulations applicable to the handling of hazardous or toxic electrical and electronic materials.

This enclosure is designed to be compliant with EU directive 2002/96/EC, and is designed to minimize the recycling costs.

Hazardous substances (including those not covered by EU directive 2002/95/EC and JIG A, section 8.3.1) have generally been avoided. Where used, the design makes them easy to separate out.

The documentation includes a Recycling Procedure for the product.

All plastic parts have been identified in accordance with ISO 1043 and ISO 11469.

The IBM ESS expansion Model 084 labeling includes the WEEE symbol:

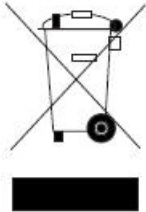

REACH

This enclosure does not contain any of the 'Substances of Very High Concern' (SVHCs) as detailed in the European Chemical Agency's document Candidate Lists of SVHCs for Authorisation.

China RoHS

The IBM ESS expansion Model 084 enclosure complies with the Phase II China RoHS requirements for self-declaration and labeling. Seagate intends that IBM ESS expansion Model 084 enclosure shall be compliant with the Phase II China RoHS requirements for testing and certification when these are finalized.

The IBM ESS expansion Model 084 enclosure labeling includes the correct Environment Friendly Use Period (EFUP) symbol, and the packaging includes the correct recycling mark.

China RoHS Declaration

EuP Directive

The IBM ESS expansion Model 084 enclosure is not yet required to comply with the Environmentally Friendly Design of Energy Using Products (EuP) directive. This directive aims to reduce the amount of energy used during the whole of the product lifecycle: manufacture, use and end of life.

The IBM ESS expansion Model 084 enclosure has been designed to comply with this directive in the future. An Environmental Impact Assessment (EIA) has been completed to provide information to support future compliance.

Packaging

The IBM ESS expansion Model 084 enclosure complies with the Packaging (Essential Requirements) Regulations 2003.

The design minimizes the amount of packaging used, and the packaging is designed for reuse, recovery or recycling, to reduce the environmental impact of packaging waste.

Acoustics

Model 084 produces an operating sound power of $< L_{WAd} 8.2$ Bels (re 1pW) at an ambient temperature of 73°F (23°C).

AC power cords

If supplying your own power cord, you must meet a number of specifications.

| Country | Cord type | Plug (AC source) | Socket (PSU socket) | Comments |
|-----------------|---|---|------------------------|-----------------------|
| USA | SJT or SVT, 12 AWG minimum, 3 conductor | IEC 320 C20, 250V, 20A or a suitable plug rated 250V, 20A | IEC 320 C19, 250V, 20A | Must be UL certified. |
| Europe & Others | Harmonized, H05-VVF-3G2.5 | IEC 320 C20, 250V, 16A or a suitable plug rated 250V, 16A | IEC 320 C19, 250V, 16A | |

Important: The plug and the complete power cord assembly must meet the standards appropriate to the country, and must have safety approvals acceptable in that country.

Potential for radio frequency interference

USA Federal Communications Commission (FCC)

Note: This equipment has been tested and found to comply with the limits for a class A digital device, pursuant to Part 15 of the FCC rules. These limits are designed to provide reasonable protection against harmful interference when the equipment is operated in a commercial environment. This equipment generates, uses and can radiate radio frequency energy and, if not installed and used in accordance with the instruction manual, may cause harmful interference to radio communications. Operation of this equipment in a residential area is likely to cause harmful interference in which case the user will be required to correct the interference at his own expense.

Properly shielded and grounded cables and connectors must be used in order to meet FCC emission limits. The supplier is not responsible for any radio or television interference caused by using other than recommended cables and connectors or by unauthorized changes or modifications to this equipment. Unauthorized changes or modifications could void the user's authority to operate the equipment.

This device complies with Part 15 of the FCC Rules. Operation is subject to the following two conditions: (1) this device may not cause harmful interference, and (2) this device must accept any interference received, including interference that may cause undesired operation.

Notices

This information was developed for products and services offered in the U.S.A.

IBM may not offer the products, services, or features discussed in this document in other countries. Consult your local IBM representative for information on the products and services currently available in your area. Any reference to an IBM product, program, or service is not intended to state or imply that only that IBM product, program, or service may be used. Any functionally equivalent product, program, or service that does not infringe any IBM intellectual property right may be used instead. However, it is the user's responsibility to evaluate and verify the operation of any non-IBM product, program, or service.

IBM may have patents or pending patent applications covering subject matter described in this document. The furnishing of this document does not grant you any license to these patents. You can send license inquiries, in writing, to:

IBM Director of Licensing IBM Corporation North Castle Drive Armonk, NY 10504-1785 U.S.A.

For license inquiries regarding double-byte (DBCS) information, contact the IBM Intellectual Property Department in your country or send inquiries, in writing, to:

Intellectual Property Licensing Legal and Intellectual Property Law IBM Japan Ltd. 19-21,
Nihonbashi-Hakozakicho, Chuo-ku Tokyo 103-8510, Japan

The following paragraph does not apply to the United Kingdom or any other country where such provisions are inconsistent with local law:

INTERNATIONAL BUSINESS MACHINES CORPORATION PROVIDES THIS PUBLICATION "AS IS" WITHOUT WARRANTY OF ANY KIND, EITHER EXPRESS OR IMPLIED, INCLUDING, BUT NOT LIMITED TO, THE IMPLIED WARRANTIES OF NON-INFRINGEMENT, MERCHANTABILITY OR FITNESS FOR A PARTICULAR PURPOSE. Some states do not allow disclaimer of express or implied warranties in certain transactions, therefore, this statement may not apply to you.

This information could include technical inaccuracies or typographical errors. Changes are periodically made to the information herein; these changes will be incorporated in new editions of the publication. IBM may make improvements and/or changes in the product(s) and/or the program(s) described in this publication at any time without notice.

Any references in this information to non-IBM Web sites are provided for convenience only and do not in any manner serve as an endorsement of those Web sites. The materials at those Web sites are not part of the materials for this IBM product and use of those Web sites is at your own risk.

IBM may use or distribute any of the information you supply in any way it believes appropriate without incurring any obligation to you.

Licensees of this program who wish to have information about it for the purpose of enabling: (i) the exchange of information between independently created programs and other programs (including this one) and (ii) the mutual use of the information which has been exchanged, should contact:

IBM Corporation
Dept. 30ZA/Building 707
Mail Station P300
2455 South Road,
Poughkeepsie, NY 12601-5400
U.S.A.

Such information may be available, subject to appropriate terms and conditions, including in some cases, payment or a fee.

The licensed program described in this document and all licensed material available for it are provided by IBM under terms of the IBM Customer Agreement, IBM International Program License Agreement or any equivalent agreement between us.

Any performance data contained herein was determined in a controlled environment. Therefore, the results obtained in other operating environments may vary significantly. Some measurements may have been made on development-level systems and there is no guarantee that these measurements will be the same on generally available systems. Furthermore, some measurements may have been estimated through extrapolation. Actual results may vary. Users of this document should verify the applicable data for their specific environment.

Information concerning non-IBM products was obtained from the suppliers of those products, their published announcements or other publicly available sources. IBM has not tested those products and cannot confirm the accuracy of performance, compatibility or any other claims related to non-IBM products. Questions on the capabilities of non-IBM products should be addressed to the suppliers of those products.

This information contains examples of data and reports used in daily business operations. To illustrate them as completely as possible, the examples include the names of individuals, companies, brands, and products. All of these names are fictitious and any similarity to the names and addresses used by an actual business enterprise is entirely coincidental.

COPYRIGHT LICENSE:

This information contains sample application programs in source language, which illustrate programming techniques on various operating platforms. You may copy, modify, and distribute these sample programs in any form without payment to IBM, for the purposes of developing, using, marketing or distributing application programs conforming to the application programming interface for the operating platform for which the sample programs are written. These examples have not been thoroughly tested under all conditions. IBM, therefore, cannot guarantee or imply reliability, serviceability, or function of these programs. The sample programs are provided "AS IS", without warranty of any kind. IBM shall not be liable for any damages arising out of your use of the sample programs.

If you are viewing this information softcopy, the photographs and color illustrations may not appear.

Trademarks

IBM, the IBM logo, and ibm.com are trademarks or registered trademarks of International Business Machines Corp., registered in many jurisdictions worldwide. Other product and service names might be trademarks of IBM or other companies. A current list of IBM trademarks is available on the Web at "[Copyright and trademark information](http://www.ibm.com/legal/copytrade.shtml)" at www.ibm.com/legal/copytrade.shtml.

Intel is a trademark of Intel Corporation or its subsidiaries in the United States and other countries.

Java™ and all Java-based trademarks and logos are trademarks or registered trademarks of Oracle and/or its affiliates.

Linux® is a registered trademark of Linus Torvalds in the United States, other countries, or both.

Microsoft, Windows, and Windows NT are trademarks of Microsoft Corporation in the United States, other countries, or both.

UNIX is a registered trademark of The Open Group in the United States and other countries.

Electronic emission notices

This section contains the electronic emission notices or statements for the United States and other countries.

Federal Communications Commission Statement

This explains the Federal Communications Commission's (FCC's) statement.

This equipment has been tested and found to comply with the limits for a Class A digital device, pursuant to Part 15 of the FCC Rules. These limits are designed to provide reasonable protection against harmful interference when the equipment is operated in a commercial environment. This equipment generates, uses, and can radiate radio frequency energy and, if not installed and used in accordance with the instruction manual, might cause harmful interference to radio communications. Operation of this equipment in a residential area is likely to cause harmful interference, in which case the user will be required to correct the interference at his own expense.

Properly shielded and grounded cables and connectors must be used in order to meet FCC emission limits. IBM is not responsible for any radio or television interference caused by using other than recommended cables and connectors, or by unauthorized changes or modifications to this equipment. Unauthorized changes or modifications could void the user's authority to operate the equipment.

This device complies with Part 15 of the FCC Rules. Operation is subject to the following two conditions: (1) this device might not cause harmful interference, and (2) this device must accept any interference received, including interference that might cause undesired operation.

Industry Canada Compliance Statement

This Class A digital apparatus complies with Canadian ICES-003.

Cet appareil numérique de la classe A est conform à la norme NMB-003 du Canada.

Australia and New Zealand Class A Statement



Attention: This is a Class A product. In a domestic environment this product might cause radio interference in which case the user might be required to take adequate measures.

European Union Electromagnetic Compatibility Directive

This product is in conformity with the protection requirements of European Union (EU) Council Directive 2004/108/EC on the approximation of the laws of the Member States relating to electromagnetic compatibility. IBM cannot accept responsibility for any failure to satisfy the protection requirements resulting from a non-recommended modification of the product, including the fitting of non-IBM option cards.



Attention: This is an EN 55022 Class A product. In a domestic environment this product might cause radio interference in which case the user might be required to take adequate measures.

Responsible Manufacturer:

International Business Machines Corp.
New Orchard Road
Armonk, New York 10504
914-499-1900

European community contact:

IBM Deutschland GmbH Technical Regulations, Department M372 IBM-Allee 1, 71139 Ehningen,
Germany Tele: +49 7032 15-2941 Email: lugi@de.ibm.com

Germany Electromagnetic Compatibility Directive

Deutschsprachiger EU Hinweis: Hinweis für Geräte der Klasse A EU-Richtlinie zur Elektromagnetischen Verträglichkeit

Dieses Produkt entspricht den Schutzanforderungen der EU-Richtlinie 2004/108/EG zur Angleichung der Rechtsvorschriften über die elektromagnetische Verträglichkeit in den EU-Mitgliedsstaaten und hält die Grenzwerte der EN 55022 Klasse A ein.

Um dieses sicherzustellen, sind die Geräte wie in den Handbüchern beschrieben zu installieren und zu betreiben. Des Weiteren dürfen auch nur von der IBM empfohlene Kabel angeschlossen werden. IBM übernimmt keine Verantwortung für die Einhaltung der Schutzanforderungen, wenn das Produkt ohne Zustimmung der IBM verändert bzw. wenn Erweiterungskomponenten von Fremdherstellern ohne Empfehlung der IBM gesteckt/eingebaut werden.

EN 55022 Klasse A Geräte müssen mit folgendem Warnhinweis versehen werden:

"Warnung: Dieses ist eine Einrichtung der Klasse A. Diese Einrichtung kann im Wohnbereich Funk-Störungen verursachen; in diesem Fall kann vom Betreiber verlangt werden, angemessene Maßnahmen zu ergreifen und dafür aufzukommen."

Deutschland: Einhaltung des Gesetzes über die elektromagnetische Verträglichkeit von Geräten

Dieses Produkt entspricht dem "Gesetz über die elektromagnetische Verträglichkeit von Geräten (EMVG)." Dies ist die Umsetzung der EU-Richtlinie 2004/108/EG in der Bundesrepublik Deutschland.

Zulassungsbescheinigung laut dem Deutschen Gesetz über die elektromagnetische Verträglichkeit von Geräten (EMVG) (bzw. der EMC EG Richtlinie 2004/108/EG) für Geräte der Klasse A

Dieses Gerät ist berechtigt, in Übereinstimmung mit dem Deutschen EMVG das EG-Konformitätszeichen - CE - zu führen.

Verantwortlich für die Einhaltung der EMV Vorschriften ist der Hersteller:

International Business Machines Corp.
New Orchard Road
Armonk, New York 10504
Tel: 914-499-1900

Der verantwortliche Ansprechpartner des Herstellers in der EU ist:

IBM Deutschland GmbH Technical Regulations, Abteilung M372 IBM-Allee 1, 71139 Ehningen, Germany
Tele: +49 7032 15-2941 Email: lugi@de.ibm.com

Generelle Informationen:

Das Gerät erfüllt die Schutzanforderungen nach EN 55024 und EN 55022 Klasse A.

People's Republic of China Class A Statement

中华人民共和国“A类”警告声明

声明

此为A级产品，在生活环境中，该产品可能会造成无线电干扰。在这种情况下，可能需要用户对其干扰采取切实可行的措施。

Taiwan Class A Statement

警告使用者：
這是甲類的資訊產品，在居住的環境中使用時，可能會造成射頻干擾，在這種情況下，使用者會被要求採取某些適當的對策。

Taiwan Contact Information

This topic contains the product service contact information for Taiwan.

IBM Taiwan Product Service Contact Information:
IBM Taiwan Corporation
3F, No 7, Song Ren Rd., Taipei Taiwan
Tel: 0800-016-888

台灣IBM 產品服務聯絡方式：
台灣國際商業機器股份有限公司
台北市松仁路7號3樓
電話：0800-016-888

12c00790

Japan Electronics and Information Technology Industries Association (JEITA) Notice

(一社) 電子情報技術産業協会 高調波電流抑制対策実施
要領に基づく定格入力電力値： Knowledge Centerの各製品の
仕様ページ参照

This statement applies to products less than or equal to 20 A per phase.

高調波電流規格 JIS C 61000-3-2 適合品

This statement applies to products greater than 20 A, single phase.

高調波電流規格 JIS C 61000-3-2 準用品

本装置は、「高圧又は特別高圧で受電する需要家の高調波抑制対策ガイドライン」対象機器（高調波発生機器）です。

- 回路分類：6（単相、PFC回路付）
- 換算係数：0

This statement applies to products greater than 20 A per phase, three-phase.

高調波電流規格 JIS C 61000-3-2 準用品

本装置は、「高圧又は特別高圧で受電する需要家の高調波抑制対策ガイドライン」対象機器（高調波発生機器）です。

- 回路分類：5（3相、PFC回路付）
- 換算係数：0

Japan Voluntary Control Council for Interference (VCCI) Notice

This explains the Japan Voluntary Control Council for Interference (VCCI) statement.

この装置は、クラスA情報技術装置です。この装置を家庭環境で使用すると電磁妨害を引き起こすことがあります。この場合には使用者が適切な対策を講ずるよう要求されることがあります。

VCCI-A

Korean Communications Commission Class A Statement

This explains the Korean Communications Commission (KCC) statement.

이 기기는 업무용(A급)으로 전자파적합기기로서 판매자 또는 사용자는 이 점을 주의하시기 바라며, 가정외의 지역에서 사용하는 것을 목적으로 합니다.

Russia Electromagnetic Interference Class A Statement

This statement explains the Russia Electromagnetic Interference (EMI) statement.

ВНИМАНИЕ! Настоящее изделие относится к классу А.
В жилых помещениях оно может создавать радиопомехи, для снижения которых необходимы дополнительные меры

RUSSIAN

Homologation statement

This product may not be certified in your country for connection by any means whatsoever to interfaces of public telecommunications networks. Further certification may be required by law prior to making any such connection. Contact an IBM representative or reseller for any questions.



SC27462802

