

IBM ESS expansion  
Version 5.1

*Quick Installation Guide - Model 084*



**Note**

Before using this information and the product it supports, read the following information:

- The general information in “Notices” on page 25
- The information in the “Safety and environmental notices” on page ix
- The information in the *IBM Environmental Notices and User Guide* (provided on a DVD)

This edition applies to IBM ESS expansion Model 084 and IBM SAS Storage Enclosure 5107-084, and is valid until replaced by new editions.

© **Copyright IBM Corporation 2018.**

US Government Users Restricted Rights – Use, duplication or disclosure restricted by GSA ADP Schedule Contract with IBM Corp.

---

# Contents

**Figures . . . . . v**

**Tables . . . . . vii**

**Safety and environmental notices . . . . ix**

Safety notices . . . . . ix

Environmental notices . . . . . xiv

IBM Elastic Storage Server Knowledge center . . . . xiv

    IBM SAS Storage Enclosure Knowledge Center . . . . xiv

Support information . . . . . xiv

**Chapter 1. Appliance safety precautions 1**

Safe handling . . . . . 1

Safety . . . . . 2

Rack system precautions . . . . . 3

Electrostatic discharge (ESD) precautions . . . . 4

Product power rating . . . . . 4

**Chapter 2. Preparation . . . . . 5**

Before you begin . . . . . 5

Unpacking the storage system . . . . . 5

**Chapter 3. Installing the appliance into a rack . . . . . 7**

Mounting the system into a rack. . . . . 7

Enclosure layout . . . . . 8

Installing and removing disk drives in carriers (DDICs) . . . . . 11

Installing and removing cooling modules, power supply units, and I/O modules. . . . . 13

**Chapter 4. LED states . . . . . 19**

I/O module LEDs . . . . . 19

Ops panel LEDs . . . . . 20

Drawer indicators . . . . . 21

Power supply unit (PSU) LEDs . . . . . 22

Cooling module LEDs . . . . . 23

**Notices . . . . . 25**

Trademarks . . . . . 26

Electronic emission notices . . . . . 27

    Federal Communications Commission Statement . . . . 27

    Industry Canada Compliance Statement . . . . . 27

    Australia and New Zealand Class A Statement . . . . 27

    European Union Electromagnetic Compatibility Directive . . . . . 27

    Germany Electromagnetic Compatibility Directive . . . . 28

    People's Republic of China Class A Statement . . . . 29

    Taiwan Class A Statement . . . . . 29

    Taiwan Contact Information . . . . . 29

    Japan Electronics and Information Technology Industries Association (JEITA) Notice . . . . . 29

    Japan Voluntary Control Council for Interference (VCCI) Notice . . . . . 30

    Korean Communications Commission Class A Statement . . . . . 30

    Russia Electromagnetic Interference Class A Statement . . . . . 31

    Statement . . . . . 31

    Homologation statement . . . . . 31



---

## Figures

1. Unpacking the storage system. . . . .	6	11. Removing a PSU (2). . . . .	15
2. Mounting the system into a rack (left rail only)	8	12. Removing a module (1). (6Gb/s SAS EBOD module shown) . . . . .	16
3. Drive numbering for drawer 1 (top). . . . .	9	13. Removing a module (2). (6Gb/s SAS EBOD module shown) . . . . .	16
4. Drive numbering for drawer 2 (bottom)	10	14. 6G I/O Module LEDs . . . . .	19
5. LED locations . . . . .	11	15. Ops panel LEDs . . . . .	20
6. Installing a DDIC . . . . .	12	16. Drawer status indicators . . . . .	22
7. Removing a DDIC . . . . .	13	17. PSU LEDs . . . . .	23
8. Removing a cooling module (1). . . . .	14	18. Cooling module LEDs . . . . .	24
9. Removing a cooling module (2). . . . .	14		
10. Removing a PSU (1). . . . .	15		



---

## Tables

1. 6G I/O Module LEDs states . . . . .	19	4. PSU LED states . . . . .	23
2. Ops module LED states . . . . .	20	5. Cooling module LED states . . . . .	24
3. Drawer LED states . . . . .	22		





---

## Safety and environmental notices

Review the safety notices, environmental notices, and electronic emission notices for IBM ESS expansion (5147-106) before you install and use the product.

**Suitability for telecommunication environment:** This product is not intended to connect directly or indirectly by any means whatsoever to interfaces of public telecommunications networks.

Here are examples of a caution and a danger notice. Numbers in parentheses refer to message numbers in the *IBM Safety Notices* publication G229-9054, which is included with your product.

### CAUTION:

**A caution notice indicates the presence of a hazard that has the potential of causing moderate or minor personal injury. (C001)**

### DANGER

<b>A danger notice indicates the presence of a hazard that has the potential of causing death or serious personal injury. (D002)</b>
--

- “Safety notices”
- “Environmental notices” on page xiv
- “Support information” on page xiv

---

## Safety notices

Required safety notices for this product.

Familiarize yourself with the *IBM Safety Notices* publication G229-9054, which is included with your product.

## DANGER

When working on or around the system, observe the following precautions:

Electrical voltage and current from power, telephone, and communication cables are hazardous. To avoid a shock hazard:

- If IBM® supplied the power cord(s), connect power to this unit only with the IBM provided power cord. Do not use the IBM provided power cord for any other product.
- Do not open or service any power supply assembly.
- Do not connect or disconnect any cables or perform installation, maintenance, or reconfiguration of this product during an electrical storm.
- The product might be equipped with multiple power cords. To remove all hazardous voltages, disconnect all power cords.
- Connect all power cords to a properly wired and grounded electrical outlet. Ensure that the outlet supplies proper voltage and phase rotation according to the system rating plate.
- Connect any equipment that will be attached to this product to properly wired outlets.
- When possible, use one hand only to connect or disconnect signal cables.
- Never turn on any equipment when there is evidence of fire, water, or structural damage.
- Do not attempt to switch on power to the machine until all possible unsafe conditions are corrected.
- Assume that an electrical safety hazard is present. Perform all continuity, grounding, and power checks specified during the subsystem installation procedures to ensure that the machine meets safety requirements.
- Do not continue with the inspection if any unsafe conditions are present.
- Disconnect the attached power cords, telecommunications system, networks, and modems before you open the device covers, unless instructed otherwise in the installation and configuration procedures.
- Connect and disconnect cables as described in the following procedures when installing, moving, or opening covers on this product or attached devices.

To disconnect:

1. Turn off everything (unless instructed otherwise).
2. Remove the power cords from the outlets.
3. Remove the signal cables from the connectors.
4. Remove all cables from the devices.

To connect:

1. Turn off everything (unless instructed otherwise).
  2. Attach all cables to the devices.
  3. Attach the signal cables to the connectors.
  4. Attach the power cords to the outlets.
  5. Turn on the devices.
- Sharp edges, corners and joints may be present in and around the system. Use care when handling equipment to avoid cuts, scrapes and pinching. (D005)

**DANGER**

Heavy equipment—personal injury or equipment damage might result if mishandled. (D006)

**DANGER**

Professional movers are to be used for all relocation activities. Serious injury or death may occur if systems are handled and moved incorrectly. (D008)

**DANGER**

Serious injury or death can occur if loaded lift tool falls over or if a heavy load falls off the lift tool. Always completely lower the lift tool load plate and properly secure the load on the lift tool before moving or using the lift tool to lift or move an object. (D010)

Do not: Throw or immerse into water, heat to more than 100°C (212°F), repair or disassemble. (C003) Use the following general safety information for all rack mounted devices:

**DANGER**

Observe the following precautions when working on or around your IT rack system:

- Heavy equipment—personal injury or equipment damage might result if mishandled.
- Always lower the leveling pads on the rack cabinet.
- Always install stabilizer brackets on the rack cabinet.
- To avoid hazardous conditions due to uneven mechanical loading, always install the heaviest devices in the bottom of the rack cabinet. Always install servers and optional devices starting from the bottom of the rack cabinet.
- Rack-mounted devices are not to be used as shelves or work spaces. Do not place objects on top of rack-mounted devices.



- Each rack cabinet might have more than one power cord. Be sure to disconnect all power cords in the rack cabinet when directed to disconnect power during servicing.
- Connect all devices installed in a rack cabinet to power devices installed in the same rack cabinet. Do not plug a power cord from a device installed in one rack cabinet into a power device installed in a different rack cabinet.
- An electrical outlet that is not correctly wired could place hazardous voltage on the metal parts of the system or the devices that attach to the system. It is the responsibility of the customer to ensure that the outlet is correctly wired and grounded to prevent an electrical shock. (R001 part 1 of 2)

(R001 part 2 of 2):

**CAUTION:**

- Do not install a unit in a rack where the internal rack ambient temperatures will exceed the manufacturer's recommended ambient temperature for all your rack-mounted devices.
- Do not install a unit in a rack where the air flow is compromised. Ensure that air flow is not blocked or reduced on any side, front, or back of a unit used for air flow through the unit.
- Consideration should be given to the connection of the equipment to the supply circuit so that overloading of the circuits does not compromise the supply wiring or overcurrent protection. To provide the correct power connection to a rack, refer to the rating labels located on the equipment in the rack to determine the total power requirement of the supply circuit.
- (For sliding drawers.) Do not pull out or install any drawer or feature if the rack stabilizer brackets are not attached to the rack. Do not pull out more than one drawer at a time. The rack might become unstable if you pull out more than one drawer at a time.



- (For fixed drawers.) This drawer is a fixed drawer and must not be moved for servicing unless specified by the manufacturer. Attempting to move the drawer partially or completely out of the rack might cause the rack to become unstable or cause the drawer to fall out of the rack. (R001 part 2 of 2)



**DANGER**

Multiple power cords. The product might be equipped with multiple power cords. To remove all hazardous voltages, disconnect all power cords. (L003)

**CAUTION:**



The weight of this part or unit is more than 55 kg (121.2 lb). It takes specially trained persons, a lifting device, or both to safely lift this part or unit. (C011)



**CAUTION:**

High levels of acoustical noise are (or could be under certain circumstances) present.

Use approved hearing protection and/ or provide mitigation or limit exposure. (L018)

---

## Environmental notices

This information contains all of the required environmental notices for IBM Systems products in English and other languages.

The IBM Systems Environmental Notices information includes statements on limitations, product information, product recycling and disposal, flat panel display, battery removal and disposal, refrigeration and water-cooling systems, external power supplies, and safety data sheets.

---

## IBM Elastic Storage™ Server Knowledge center

The latest IBM ESS expansion publications are available on the IBM ESS knowledge center.

## IBM SAS Storage Enclosure Knowledge Center

The latest IBM SAS Storage Enclosure publications are available on the IBM Power Systems™ knowledge center.

---

## Support information

Your location	Method of contacting the IBM Support Center
In the United States	Call <b>1-800-IBM-SERV</b> for support.
Outside the United States	Contact your local IBM Support Center or see the Directory of worldwide contacts.

---

## Chapter 1. Appliance safety precautions

Observe physical, electrical, and electronic component safety precautions.

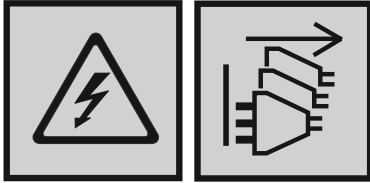

### DANGER

An electrical outlet that is not correctly wired could place hazardous voltage on the metal parts of the system or the devices that attach to the system. It is the responsibility of the customer to ensure that the outlet is correctly wired and grounded to prevent an electrical shock. (D004)

### DANGER

Multiple power cords. The product might be equipped with multiple power cords. To remove all hazardous voltages, disconnect all power cords. (L003)

**Important:** The enclosure *must* be mounted in a rack.

---

## Safe handling

Handle the enclosure with care.

### CAUTION:



The weight of this part or unit is more than 55 kg (121.2 lb). It takes specially trained persons, a lifting device, or both to safely lift this part or unit. (C011)



### CAUTION:

An unpopulated enclosure can weigh up to 46kg (101lb). At least three people are required to lift and install the enclosure into the rack or to remove an enclosure from the rack. It takes specially trained persons, a lifting device, or both to safely lift this part or unit.

- A fully populated enclosure weighs 135kg (298lb). Only lift the enclosure when the drawers are empty and latched closed.

- Important:** Do not attempt to lift the enclosure when populated with drives.
- Do not lift the enclosure by the handles on the rear modules. They are not designed to take the weight. Only lift from underneath the main chassis.
  - When closing the drawers, do so firmly, ensuring the latches are engaged.

---

## Safety

### CAUTION:

**If this equipment is used in a manner not specified by the manufacturer, the protection provided by the equipment might be impaired.**

- All rear modules are part of the fire enclosure and must only be removed when a replacement can be immediately added. The system must not be run without all modules in place.
- Unplug the unit before you move it or if you think it has become damaged in any way.
- A safe electrical ground connection must be provided to the power supply cords.

**Important:** The enclosure must be grounded before applying power.

- The plug on the power supply cord is used as the main disconnect device. Ensure that the socket outlets are located near the equipment and are easily accessible.
- When powered by multiple AC sources, disconnect all supply power for complete isolation.
- In order to comply with applicable safety, emission, and thermal requirements, carry out the following precautions:
  - Do not remove any covers
  - Populate all rear bays with plug-in modules
- The power connection should always be disconnected prior to insertion or removal of a power supply unit (PSU) from the enclosure.
- Do not attempt to disassemble the rear sub-chassis from the enclosure.
- Provide a suitable power source with electrical overload protection to meet the requirements laid down in the technical specification.

### CAUTION:

**Operating temperatures inside the enclosure drawers can reach up to 60°C. Take care when opening drawers and removing drive carriers.**

- If any component of the product fails, consult your storage vendor.
- Do not remove Cooling Modules, PSUs or I/O Modules unless you have a replacement model of the correct type ready for insertion.
- For use in North America, each branch circuit must be rated for 20A.
- This equipment is suitable for connection to an IT power system (Norway).

### CAUTION:

**Double pole/neutral fusing in PSUs.**

### CAUTION:

**Risk of explosion if the battery within the RAID controller is replaced with an incorrect type. Dispose of used batteries according to the instructions. There are no user serviceable parts within the RAID controller.**

**Important:** The optional RJ45 socket on the I/O module is for Ethernet connection only. Do not connect it to a telecommunications network.

### CAUTION:

**Due to product acoustics, it is recommended that users wear ear protection for any prolonged exposure.**



**CAUTION:**

To prevent overturning, drawer interlocks stop users from opening both drawers at the same time. Do not attempt to force open a drawer when the other drawer is already open.

---

## Rack system precautions

The enclosure must be mounted in a rack. Consider the following safety requirements when mounting the enclosure:

- The rack construction must be capable of supporting the total weight of the installed enclosure(s) and the design should incorporate stabilizing features suitable to prevent the rack tipping or being pushed over during installation or in normal use.
- When loading a rack with enclosures, fill from the bottom up; empty from the top down.
- To avoid danger of the rack toppling over, do not slide more than one enclosure out of the rack at a time.
- The system must be operated with low pressure rear exhaust installation. The back pressure created by rack doors and obstacles is not to exceed 5 Pascals (0.5mm water gauge).
- The rack design should take into consideration the maximum operating ambient temperature for the unit, which is 35°C when fitted with RAID controllers, or 40°C when fitted with EBOD controllers.
- The rack should have a safe electrical distribution system. It must provide over-current protection for the unit and must not be overloaded by the total number of units installed in the rack. When addressing these concerns, consider the electrical power consumption rating shown on the nameplate.
- The electrical distribution system must provide a reliable ground for each unit in the rack.
- The design of the electrical distribution system must take into consideration the total ground leakage current from all the PSUs in all the units. The rack might require labeling with "HIGH LEAKAGE CURRENT. Ground connection essential before connecting supply."



**DANGER**

Rack-mounted devices are not to be used as shelves or work spaces. (L002)



**CAUTION:**

Do not pull out more than one drawer at a time. The rack might become unstable if you pull out more than one drawer at a time. (L024)

---

## **Electrostatic discharge (ESD) precautions**

Fit and check a suitable anti-static wrist or ankle strap and observe all conventional ESD precautions when handling plug-in modules and components. Avoid contact with backplane components, module connectors, and other potential sources of ESD.

---

## **Product power rating**

Product rating information can also be found on the back of the PSUs.

The product has the following ratings:

- Voltage: 200 to 240 VAC
- Current: 16A
- Frequency: 50 to 60 Hz.

---

## Chapter 2. Preparation

Before you install the system, verify the location and installable components.

---

### Before you begin

Before you begin installing the product, you must meet certain requirements.

Make sure that the site where you intend to set up and use your storage system can meet the following needs:

- Standard power from an independent source or a rack power distribution unit with a UPS.
- Host computer with the correct firmware, BIOS and drivers. Contact your supplier for the correct software levels.

Before setting up your enclosure, ensure that you have the following accessories:

- SAS HBA
- Mini-SAS to Host Cable
- Power Cord
- Rack kit (if installing within a rack)

#### Note:

1. ESS solution ships with SAS-HBA installed in the ESS IO Server nodes along with the necessary cables.
2. Required firmware and drives are updated by the ESS software. For further details, see the *Deploying the Elastic Storage Server* guide.

Refer to your supplier for a list of qualified accessories for use with the enclosure. The accessory box contains the power cords and other ordered accessories

---

### Unpacking the storage system

Read these instructions before unpacking the system.

1. Position the shipping case within 2m (6 feet) of the site where you intend to use your storage system.
2. Inspect the packaging for crushes, cuts, water damage or any other evidence of mishandling during transit. If there is any damage, photograph the packaging for future reference before opening.
3. Unpack the system, as shown in the following figure.

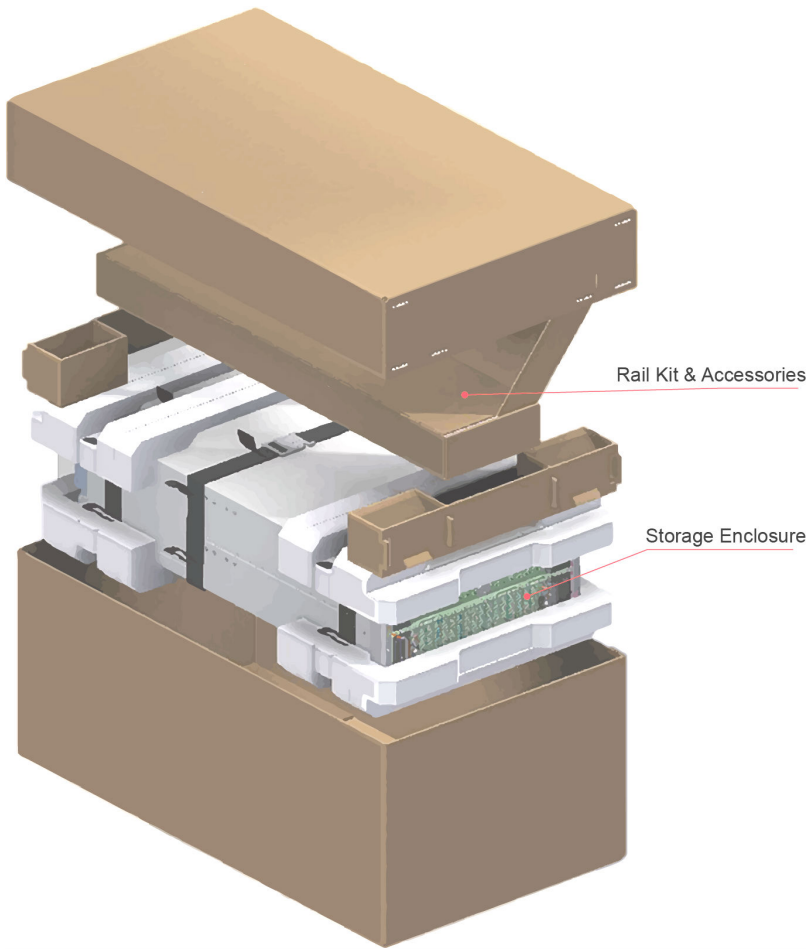

Figure 1. Unpacking the storage system

---

## Chapter 3. Installing the appliance into a rack

There are many racks in the market, which means that the assembly procedure might differ slightly.

---

### Mounting the system into a rack

Follow these steps to install the rails to the rack and to the enclosure.

**CAUTION:**

Ensure that you have fitted and checked a suitable anti-static wrist or ankle strap and observe all conventional ESD precautions when handling modules and components. Avoid contact with backplane components, module connectors, and other potential sources of ESD. ESD damage is not covered by warranty.

**Note:** Rail Kit Adjustment Range:

Inside of the front post to inside of the rear post: 281 in. - 348 in. (713mm - 884mm). Suits a 1-meter-deep rack (39 in.) within Rack Specification IEC 60297.

**Note:** A Torx T20 screwdriver is needed to lock and unlock the drawers.

**CAUTION:**

A fully populated enclosure can weigh upto 135kg (298lbs). Do not try to lift it by yourself.

**Note:** The rail location pins are pre-assembled to suit square and round hole racks only.

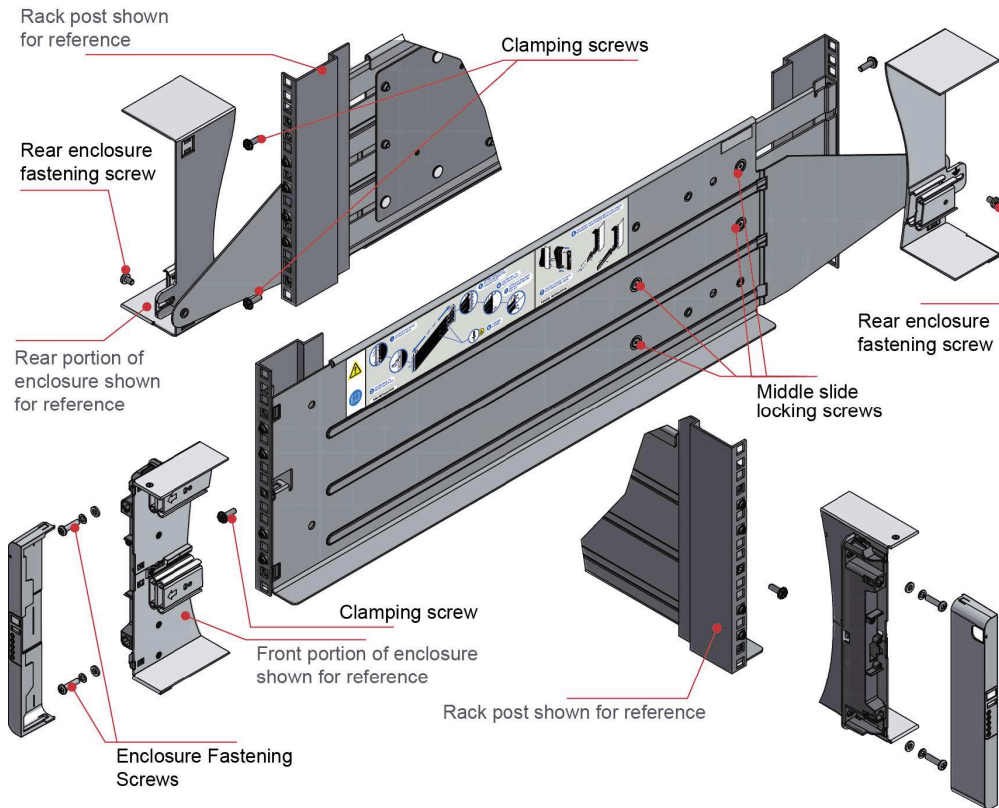

Figure 2. Mounting the system into a rack (left rail only)

1. Ensure the pre-assembled rail is at its shortest length.
2. Locate the rail location pins inside the front of the rack and extend the length of the rail assembly to enable the rear location pins to locate. Ensure the pins are fully located in the square or round holes in the rack posts (see Figure 2).
3. Fully tighten all clamping screws (left and right).
4. Slide the enclosure fully home on its rails.
5. Fasten the front of the enclosure using the enclosure fastening screws and washers (x4) as shown in Figure 2.
6. Fix the rear of the enclosure to the hold down bracket with the rear enclosure fixing screws (x2), fitted from inside the enclosure.

---

## Enclosure layout

The enclosure contains 84 drives, five cooling modules, and two PSUs.

### Drive locations

The following figures show the locations of the drives within the enclosure.

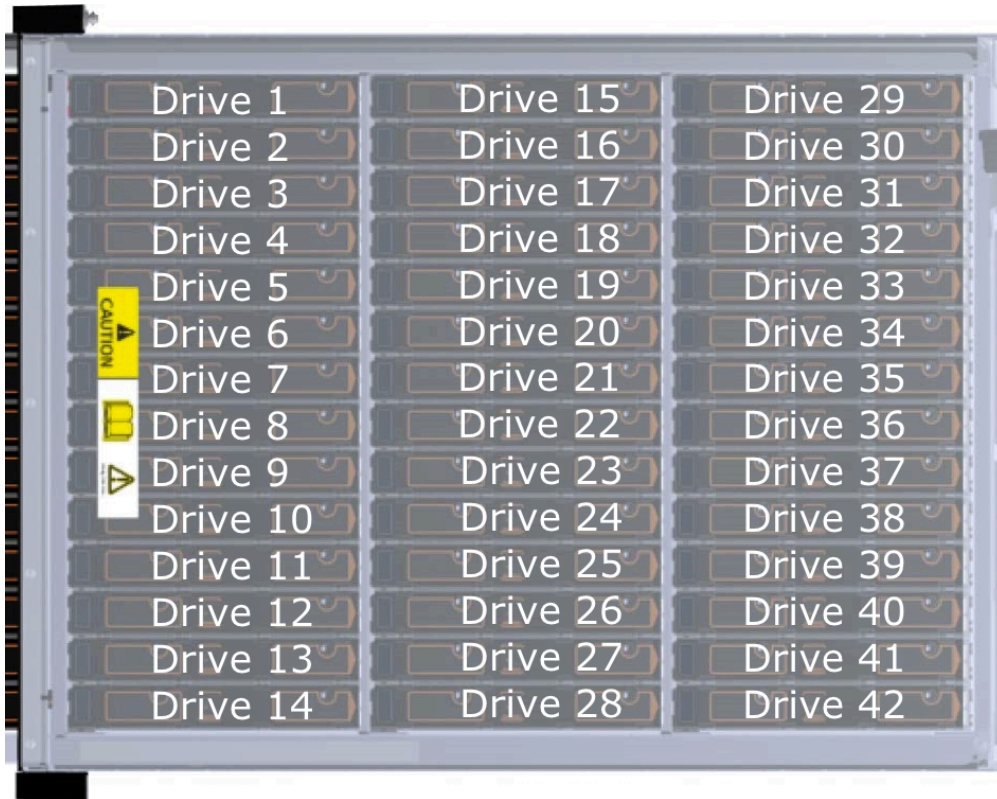

Figure 3. Drive numbering for drawer 1 (top)

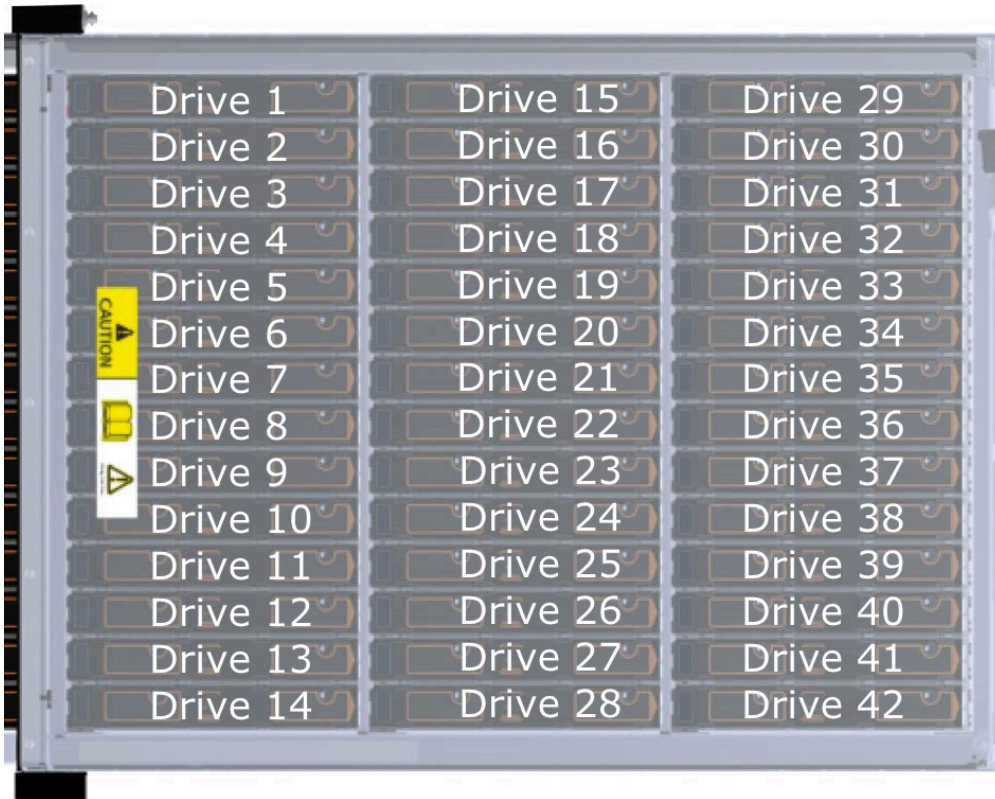

Figure 4. Drive numbering for drawer 2 (bottom)

### Front and rear LEDs and modules

The following figure shows the locations of LEDs on the front of the enclosure and the modules on the back. For detailed information about the LEDs, see Chapter 4, "LED states," on page 19.



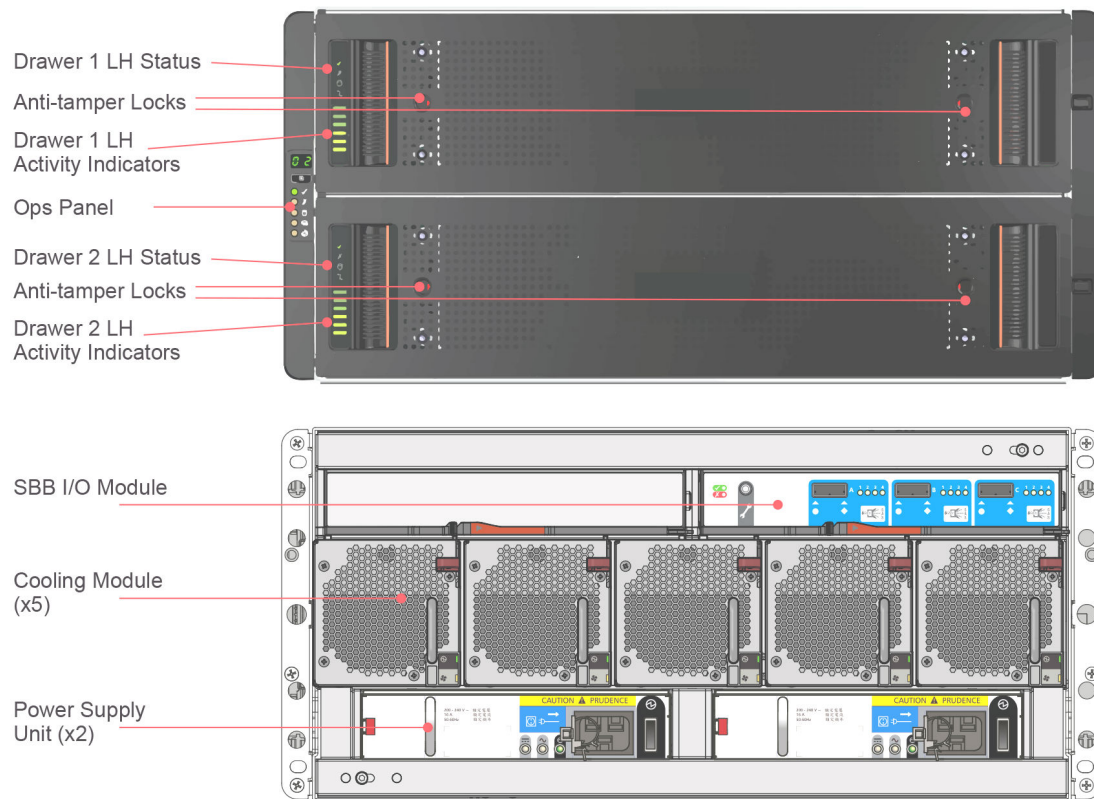

Figure 5. LED locations

## Installing and removing disk drives in carriers (DDICs)

### Installing a DDIC

To install a DDIC, complete the following steps:

1. Insert the DDIC carrier into the slot, and then push it down until it stops, as shown in the following figure.

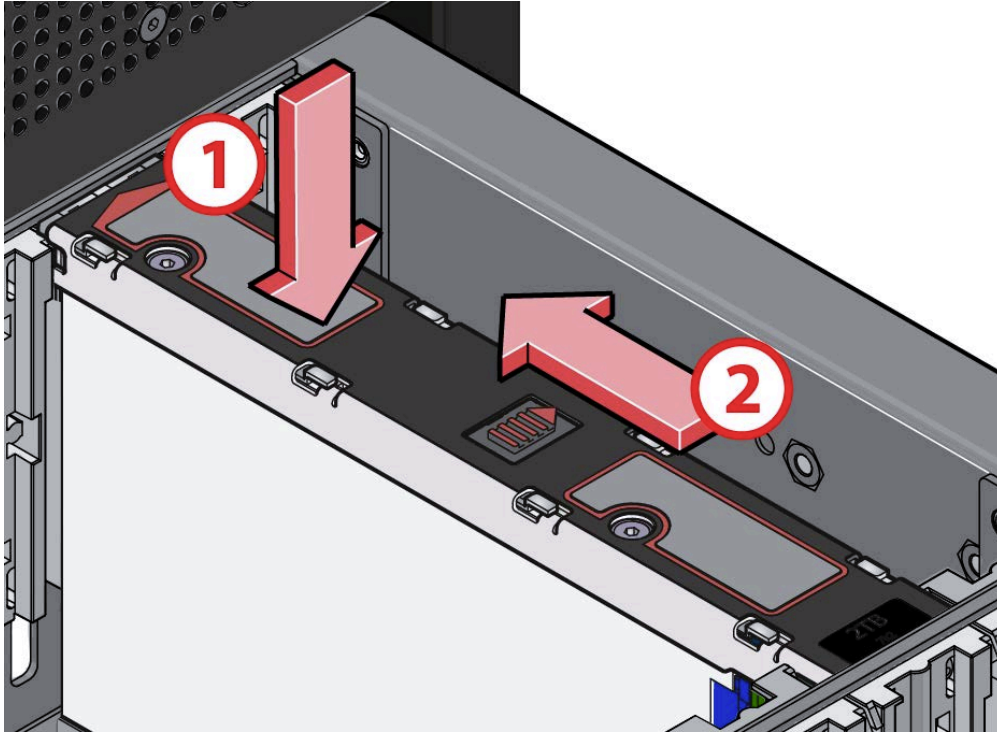

Figure 6. Installing a DDIC

2. Slide the top latch in the direction of the arrow until the latch clicks into place (see Figure 6).

## Removing a DDIC

To remove a DDIC, complete the following steps:

1. Slide the release button and the DDIC will pop up slightly from the slot, as shown in the following figure.

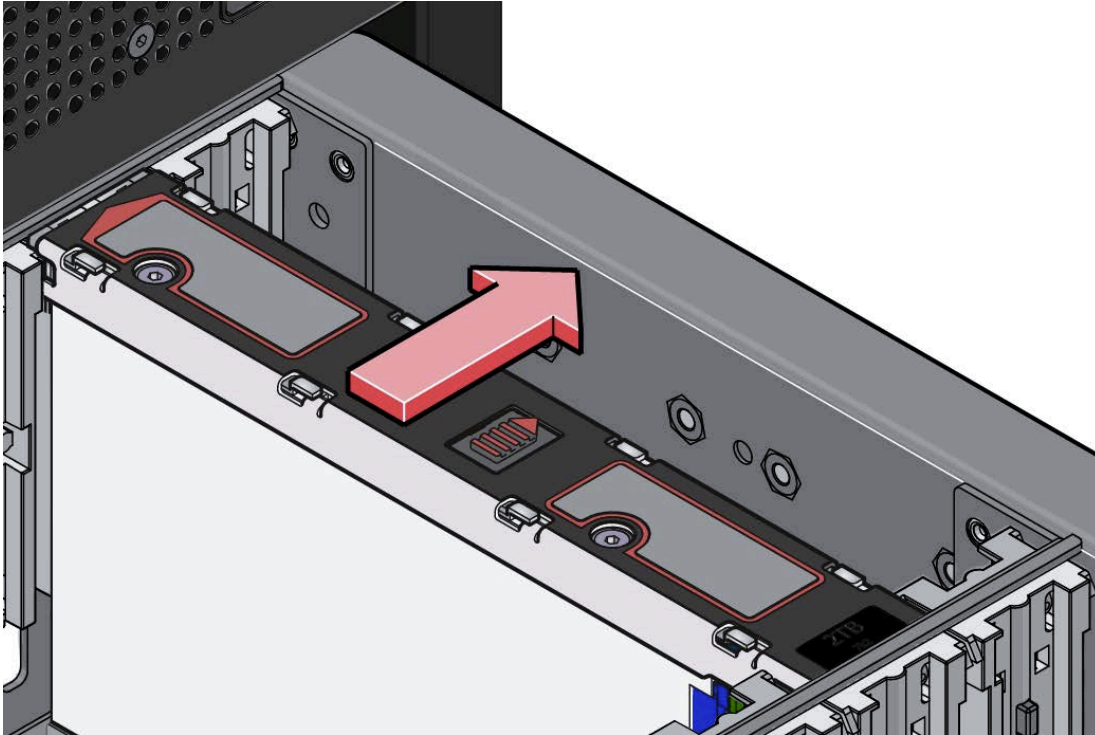

Figure 7. Removing a DDIC

2. Lift the DDIC out of the slot.

---

## Installing and removing cooling modules, power supply units, and I/O modules

Observe proper safety precautions when replacing any of these modules.

### DANGER

Multiple power cords. The product might be equipped with multiple power cords. To remove all hazardous voltages, disconnect all power cords. (L003)

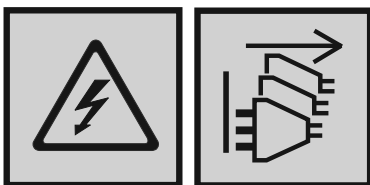

### CAUTION:

Handle the modules carefully and avoid damaging the connector pins. Do not install if any pins appear to be bent.

### CAUTION:

Do not remove these modules unless a replacement can be immediately added. The system must not be run without all modules in place.

## Removing a cooling module

1. Depress the retaining latch, as shown in the following figure.

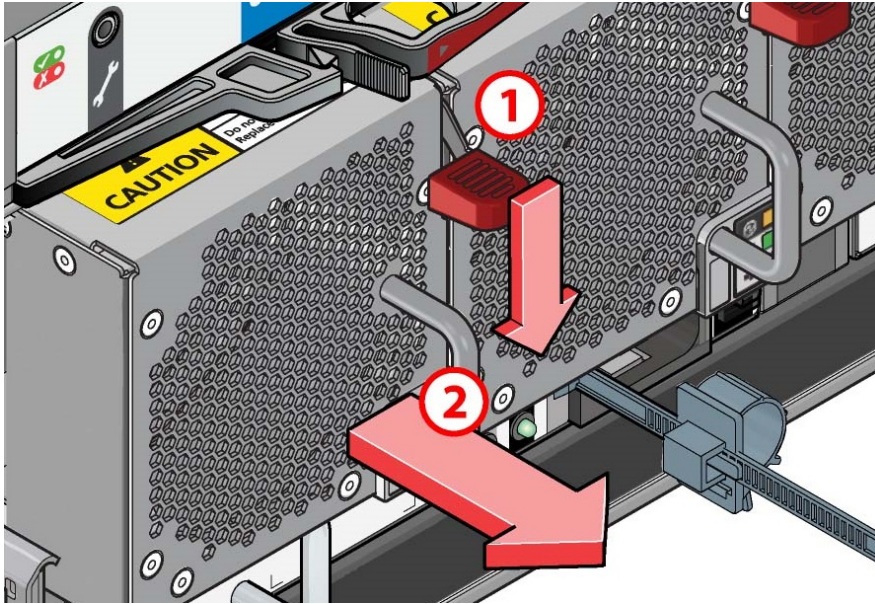

Figure 8. Removing a cooling module (1)

2. Pull the cooling module handle until the unit is completely free of the enclosure, as shown in the following figure.

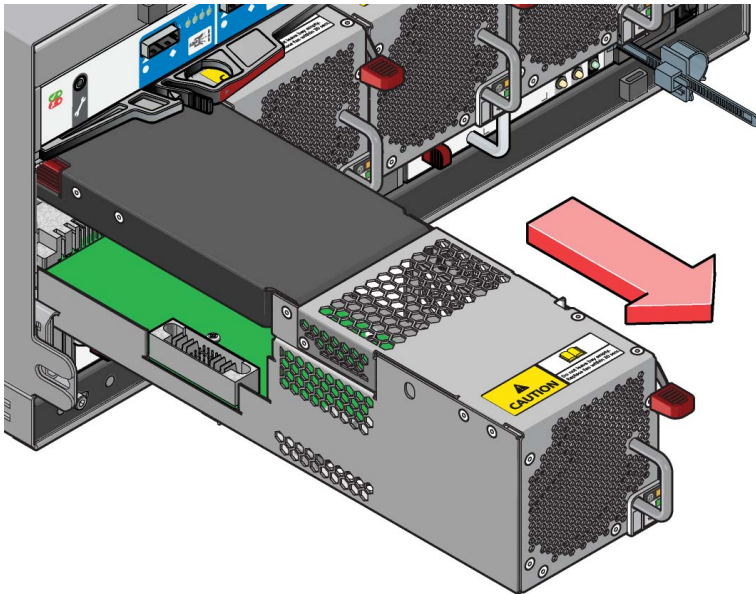

Figure 9. Removing a cooling module (2)

## Installing a cooling module

Installation is the reverse of the removal process. Ensure that the retaining latch clicks into place.

## Removing a power supply unit (PSU)

### CAUTION:

Do not remove covers from the PSU. Danger of electric shock inside. Return the PSU to your supplier for repair.

1. Squeeze the retaining latch, as shown in the following figure.

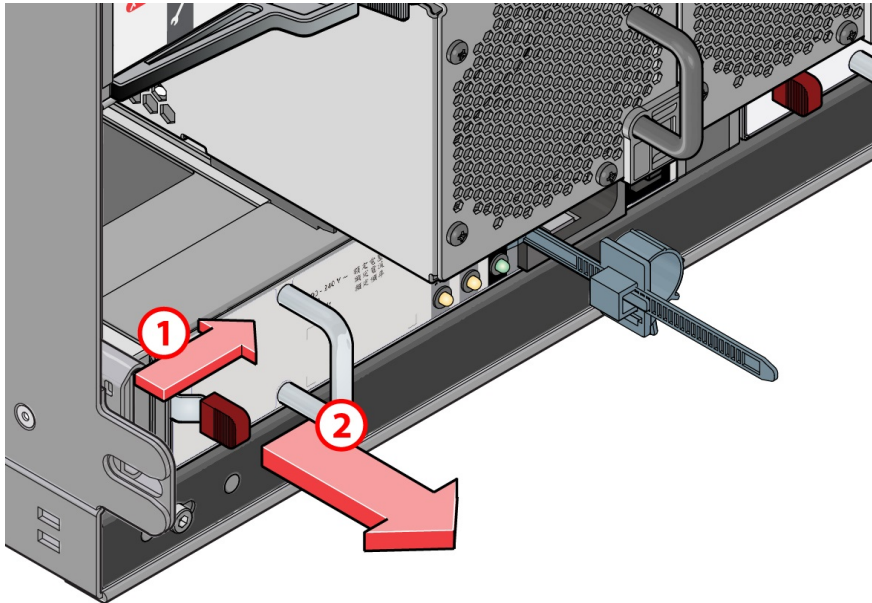

Figure 10. Removing a PSU (1)

2. Pull the PSU handle until the unit is completely free of the enclosure, as shown in the following figure.

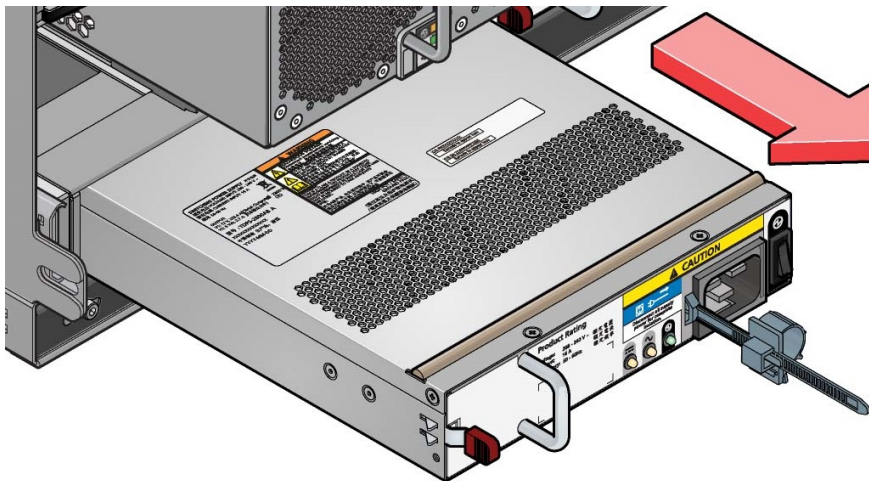

Figure 11. Removing a PSU (2)

## Installing a PSU

Installation is the reverse of the removal process. Ensure that the retaining latch clicks into place.

## Removing an I/O module

1. Grasp the module latch between the thumb and forefinger and squeeze them together to release the latch, as shown in the following figure.

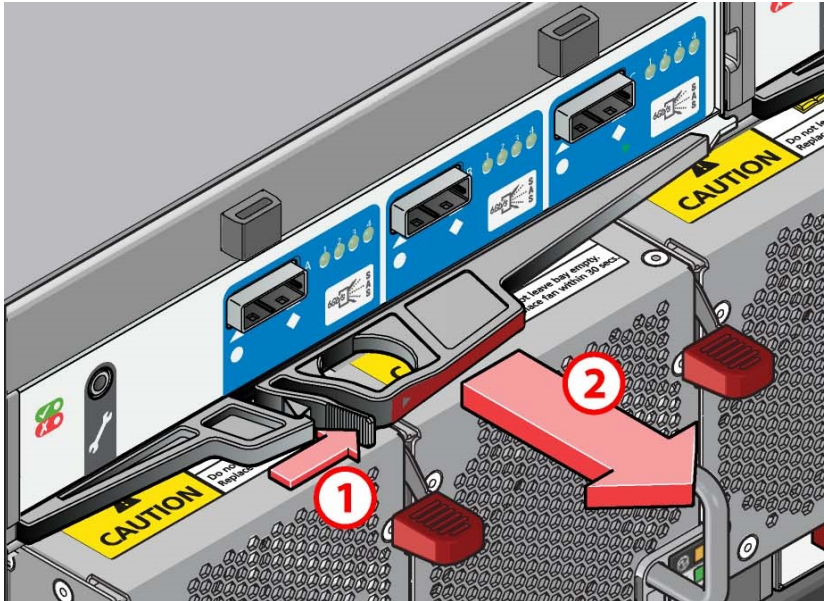

Figure 12. Removing a module (1). (6Gb/s SAS EBOD module shown)

2. Pull the latch outward to cam the module out of the enclosure.
3. Grip the latch handles and withdraw the module, as shown in the following figure.

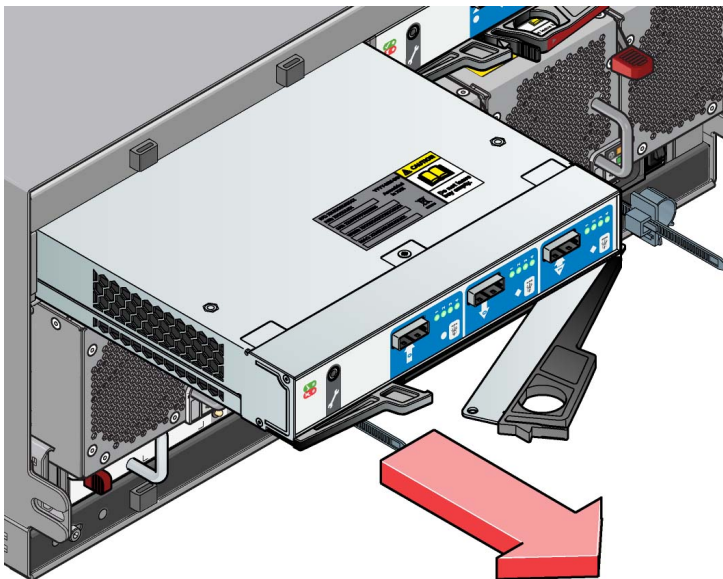

Figure 13. Removing a module (2). (6Gb/s SAS EBOD module shown)

## Installing an I/O module

1. With the latches in the open position, slide the module into the enclosure until the latches engage automatically.
2. Cam the module home by manually closing the latches.

3. A click should be heard as the latches engage.





## Chapter 4. LED states

Use the combination of LED states on the appliance to diagnose problems.

### I/O module LEDs

I/O module LEDs show faults and port activity.

The following figure shows the location of the LEDs on the I/O module.

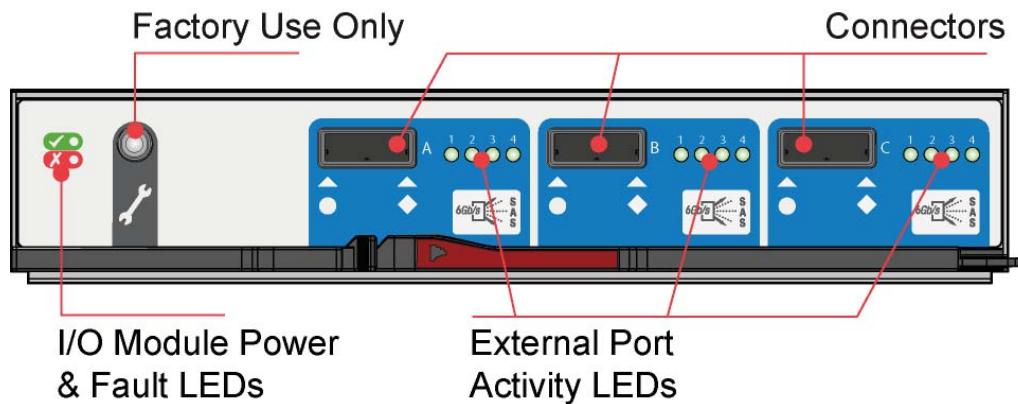

Figure 14. 6G I/O Module LEDs

Table 1. 6G I/O Module LEDs states

I/O Module OK (Green)	I/O Module Fault (Amber)	Host Port Activity (Green)	Status
On	Off	X	I/O module OK
Off	On	X	I/O module fault
X	X	Off	No external host port connection
X	X	On	External host port connection - no activity
X	X	Flashing	External host port connection - activity
Flashing	X	X	I/O module VPD error
X = disregard			

### External Port Activity LEDs

If all the LEDs under "1234" are off then no external connection is detected.

If one of the LEDs under "1234" is off then one of the port lanes have an issue. The issue can be one of the following

- Possible Cable issue.
- Possible HBA port issue.
- Possible Enclosure IOM issue.

## Ops panel LEDs

Ops panel LEDs show logical status and faults by drawer.

The following figure shows the LEDs on the Ops panel.

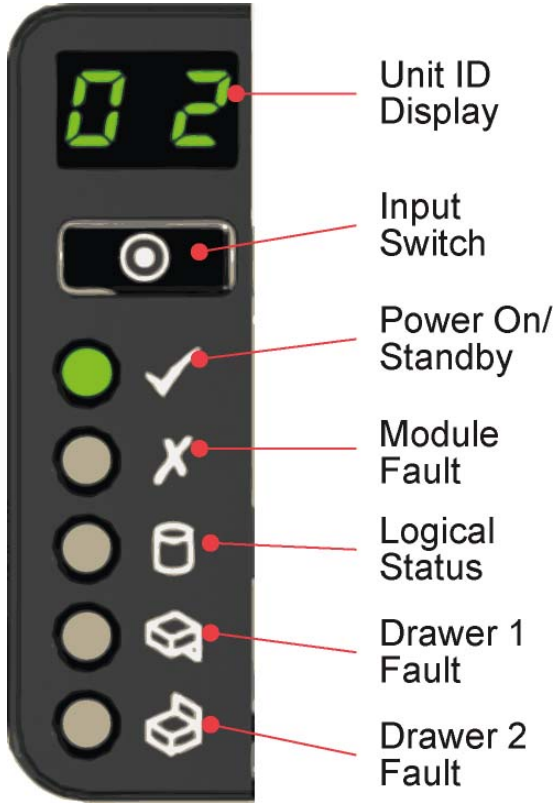

Figure 15. Ops panel LEDs

Table 2. Ops module LED states

Unit ID display	Power (green/amber)	Module fault (amber)	Logical status (amber)	Drawer 1 fault	Drawer 2 fault	Associated LEDs or alarms	Status
X	On	Off	Off	Off	Off		Aux present, overall power failed or off
X	On	On	X	X	X	Single beep, then double	Ops panel power on (5s) test state
X	On	Off	Off	Off	Off		Power on, all functions good
X	On	On	X	Off	Off	PSU fault LEDs, fan fault LEDs	Any PSU fault, fan fault, over or under temperature
X	On	On	X	Off	Off	SBB module LEDs	Any SBB module fault
X	On	Flashing	X	Off	Off		Enclosure logical fault such as VPD configuration error

Table 2. Ops module LED states (continued)

Unit ID display	Power (green/amber)	Module fault (amber)	Logical status (amber)	Drawer 1 fault	Drawer 2 fault	Associated LEDs or alarms	Status
X	On	Flashing	X	Off	Off	Module status LED on SBB module	Unknown SBB module type installed, I2C Bus failure, or VPD configuration error
X	On	Flashing	X	Off	Off	PSU fault LEDs, fan fault LEDs	Unknown (invalid or mixed) PSU module type installed, or I2C Bus failure (PSU comms)
X	On	On	X	Off	Off	DDIC fault LED, drawer fault LED	Drive failure has occurred causing loss of availability or redundancy
X	On	Flashing	Flashing	Off	Off	S1	Unit ID number different from "Start Of Day"
X	On	X	X	On	Off	Fault LED on Drawer 1	Fault present on drawer 1 (drive, cable or fanout card fault)
X	On	X	X	Off	On	Fault LED on Drawer 2	Fault present on drawer 2 (drive, cable or fanout card fault)
Flashing	X	X	X	X	X		SES controlled enclosure identify
X = disregard							

## Drawer indicators

Each of the two drawers has its own set of status indicators.

The following figure shows the LEDs for a drive drawer.

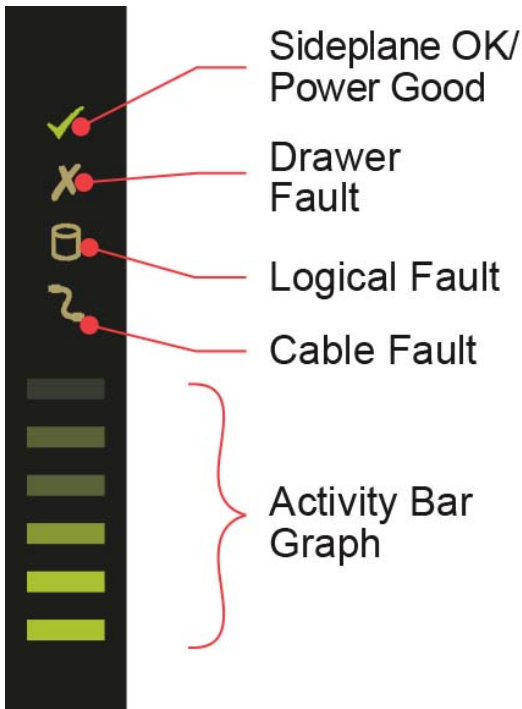

Figure 16. Drawer status indicators

Table 3. Drawer LED states

Sideplane OK / power (green)	Sideplane fault (amber)	Logical fault (amber)	Cable fault (amber)	Activity bar graph (green)	Status
On	Off	Off	Off	X	Sideplane card OK/Power good
Off	On	X	X	Off	Sideplane card fault
On	On	X	X	X	Drive failure has occurred which may cause loss of availability or redundancy
On	X	On	X	X	Drive fault (Host indicated)
Off	X	X	On	Off	Cable fault
On	Off	Off	Off	On*	Drive activity

\*The Activity Bar Graph is a 6-segment drive activity meter, showing activity of the SAS interface to the sideplane. For zero activity, no segments are lit, scaling linearly until all segments are lit when the interface is transferring data at full capacity.

X = disregard

## Power supply unit (PSU) LEDs

Each PSU has its own indicators.

The following figure shows the LEDs for the power supply.

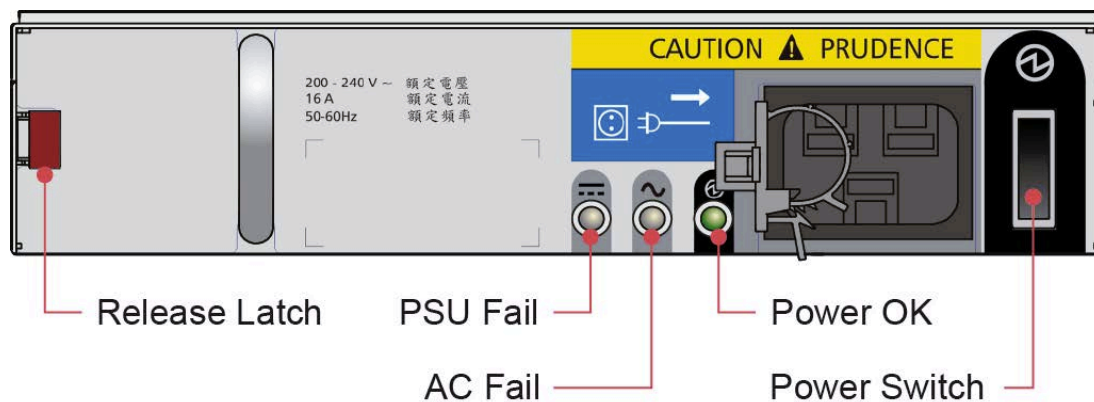

Figure 17. PSU LEDs

Table 4. PSU LED states

PSU fail (amber)	AC fail (amber)	Power OK (green)	Status
Off	Off	Off	No AC power to either PSU
On	On	Off	PSU present but not supplying power
Off	Off	On	Main AC present, switch on; PSU is providing power output.
Off	Off	Flashing	AC power present, PSU in Standby mode (meaning the other PSU is currently providing power output)
Flashing	Flashing	Off	PSU firmware download
On	On	Off	PSU alert state, usually due to critical temperature
Off	On	Off	Main AC to this PSU is missing; this PSU is now on standby, and the other PSU is OK
On	On	On	GEM software lost communication with PSU
On	X	Off	PSU failed.

X = disregard

## Cooling module LEDs

Cooling modules have LEDs for the module status and fan faults.

The following figure shows the LEDs for a cooling module.

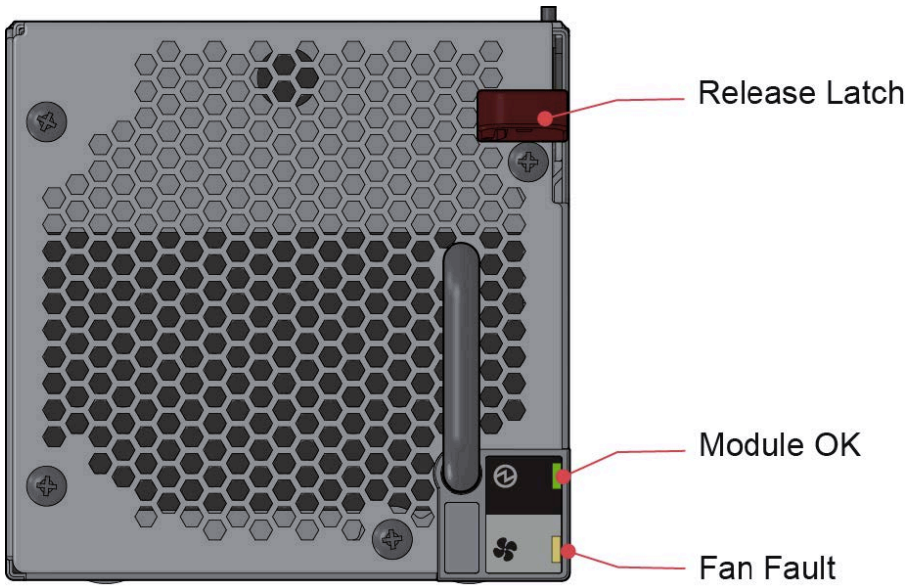

Figure 18. Cooling module LEDs

Table 5. Cooling module LED states

Module OK (green)	Fan fault (amber)	Status
X	Off	Fan OK
X	On	Communication lost with fan module controller
X	On	Reported fan speed is out of tolerance
On	X	Module good
X = disregard		

---

## Notices

This information was developed for products and services offered in the U.S.A.

IBM may not offer the products, services, or features discussed in this document in other countries. Consult your local IBM representative for information on the products and services currently available in your area. Any reference to an IBM product, program, or service is not intended to state or imply that only that IBM product, program, or service may be used. Any functionally equivalent product, program, or service that does not infringe any IBM intellectual property right may be used instead. However, it is the user's responsibility to evaluate and verify the operation of any non-IBM product, program, or service.

IBM may have patents or pending patent applications covering subject matter described in this document. The furnishing of this document does not grant you any license to these patents. You can send license inquiries, in writing, to:

IBM Director of Licensing IBM Corporation North Castle Drive Armonk, NY 10504-1785 U.S.A.

For license inquiries regarding double-byte (DBCS) information, contact the IBM Intellectual Property Department in your country or send inquiries, in writing, to:

Intellectual Property Licensing Legal and Intellectual Property Law IBM Japan Ltd. 19-21,

Nihonbashi-Hakozakicho, Chuo-ku Tokyo 103-8510, Japan

The following paragraph does not apply to the United Kingdom or any other country where such provisions are inconsistent with local law:

INTERNATIONAL BUSINESS MACHINES CORPORATION PROVIDES THIS PUBLICATION "AS IS" WITHOUT WARRANTY OF ANY KIND, EITHER EXPRESS OR IMPLIED, INCLUDING, BUT NOT LIMITED TO, THE IMPLIED WARRANTIES OF NON-INFRINGEMENT, MERCHANTABILITY OR FITNESS FOR A PARTICULAR PURPOSE. Some states do not allow disclaimer of express or implied warranties in certain transactions, therefore, this statement may not apply to you.

This information could include technical inaccuracies or typographical errors. Changes are periodically made to the information herein; these changes will be incorporated in new editions of the publication. IBM may make improvements and/or changes in the product(s) and/or the program(s) described in this publication at any time without notice.

Any references in this information to non-IBM Web sites are provided for convenience only and do not in any manner serve as an endorsement of those Web sites. The materials at those Web sites are not part of the materials for this IBM product and use of those Web sites is at your own risk.

IBM may use or distribute any of the information you supply in any way it believes appropriate without incurring any obligation to you.

Licensees of this program who wish to have information about it for the purpose of enabling: (i) the exchange of information between independently created programs and other programs (including this one) and (ii) the mutual use of the information which has been exchanged, should contact:

IBM Corporation  
Dept. 30ZA/Building 707  
Mail Station P300

2455 South Road,  
Poughkeepsie, NY 12601-5400  
U.S.A.

Such information may be available, subject to appropriate terms and conditions, including in some cases, payment or a fee.

The licensed program described in this document and all licensed material available for it are provided by IBM under terms of the IBM Customer Agreement, IBM International Program License Agreement or any equivalent agreement between us.

Any performance data contained herein was determined in a controlled environment. Therefore, the results obtained in other operating environments may vary significantly. Some measurements may have been made on development-level systems and there is no guarantee that these measurements will be the same on generally available systems. Furthermore, some measurements may have been estimated through extrapolation. Actual results may vary. Users of this document should verify the applicable data for their specific environment.

Information concerning non-IBM products was obtained from the suppliers of those products, their published announcements or other publicly available sources. IBM has not tested those products and cannot confirm the accuracy of performance, compatibility or any other claims related to non-IBM products. Questions on the capabilities of non-IBM products should be addressed to the suppliers of those products.

This information contains examples of data and reports used in daily business operations. To illustrate them as completely as possible, the examples include the names of individuals, companies, brands, and products. All of these names are fictitious and any similarity to the names and addresses used by an actual business enterprise is entirely coincidental.

#### COPYRIGHT LICENSE:

This information contains sample application programs in source language, which illustrate programming techniques on various operating platforms. You may copy, modify, and distribute these sample programs in any form without payment to IBM, for the purposes of developing, using, marketing or distributing application programs conforming to the application programming interface for the operating platform for which the sample programs are written. These examples have not been thoroughly tested under all conditions. IBM, therefore, cannot guarantee or imply reliability, serviceability, or function of these programs. The sample programs are provided "AS IS", without warranty of any kind. IBM shall not be liable for any damages arising out of your use of the sample programs.

If you are viewing this information softcopy, the photographs and color illustrations may not appear.

---

## Trademarks

IBM, the IBM logo, and [ibm.com](http://www.ibm.com) are trademarks or registered trademarks of International Business Machines Corp., registered in many jurisdictions worldwide. Other product and service names might be trademarks of IBM or other companies. A current list of IBM trademarks is available on the Web at "Copyright and trademark information" at [www.ibm.com/legal/copytrade.shtml](http://www.ibm.com/legal/copytrade.shtml).

Intel is a trademark of Intel Corporation or its subsidiaries in the United States and other countries.

Java™ and all Java-based trademarks and logos are trademarks or registered trademarks of Oracle and/or its affiliates.

Linux is a registered trademark of Linus Torvalds in the United States, other countries, or both.



Microsoft, Windows, and Windows NT are trademarks of Microsoft Corporation in the United States, other countries, or both.

UNIX is a registered trademark of The Open Group in the United States and other countries.

---

## Electronic emission notices

This section contains the electronic emission notices or statements for the United States and other countries.

### Federal Communications Commission Statement

This explains the Federal Communications Commission's (FCC's) statement.

This equipment has been tested and found to comply with the limits for a Class A digital device, pursuant to Part 15 of the FCC Rules. These limits are designed to provide reasonable protection against harmful interference when the equipment is operated in a commercial environment. This equipment generates, uses, and can radiate radio frequency energy and, if not installed and used in accordance with the instruction manual, might cause harmful interference to radio communications. Operation of this equipment in a residential area is likely to cause harmful interference, in which case the user will be required to correct the interference at his own expense.

Properly shielded and grounded cables and connectors must be used in order to meet FCC emission limits. IBM is not responsible for any radio or television interference caused by using other than recommended cables and connectors, or by unauthorized changes or modifications to this equipment. Unauthorized changes or modifications could void the user's authority to operate the equipment.

This device complies with Part 15 of the FCC Rules. Operation is subject to the following two conditions: (1) this device might not cause harmful interference, and (2) this device must accept any interference received, including interference that might cause undesired operation.

### Industry Canada Compliance Statement

This Class A digital apparatus complies with Canadian ICES-003.

Cet appareil numérique de la classe A est conforme à la norme NMB-003 du Canada.

### Australia and New Zealand Class A Statement

**Attention:** This is a Class A product. In a domestic environment this product might cause radio interference in which case the user might be required to take adequate measures.

### European Union Electromagnetic Compatibility Directive

This product is in conformity with the protection requirements of European Union (EU) Council Directive 2004/108/EC on the approximation of the laws of the Member States relating to electromagnetic compatibility. IBM cannot accept responsibility for any failure to satisfy the protection requirements resulting from a non-recommended modification of the product, including the fitting of non-IBM option cards.

**Attention:** This is an EN 55022 Class A product. In a domestic environment this product might cause radio interference in which case the user might be required to take adequate measures.

Responsible Manufacturer:

International Business Machines Corp.  
New Orchard Road  
Armonk, New York 10504  
914-499-1900

European community contact:

IBM Deutschland GmbH Technical Regulations, Department M372 IBM-Allee 1, 71139 Ehningen, Germany Tele: +49 7

## **Germany Electromagnetic Compatibility Directive**

### **Deutschsprachiger EU Hinweis: Hinweis für Geräte der Klasse A EU-Richtlinie zur Elektromagnetischen Verträglichkeit**

Dieses Produkt entspricht den Schutzanforderungen der EU-Richtlinie 2004/108/EG zur Angleichung der Rechtsvorschriften über die elektromagnetische Verträglichkeit in den EU-Mitgliedsstaaten und hält die Grenzwerte der EN 55022 Klasse A ein.

Um dieses sicherzustellen, sind die Geräte wie in den Handbüchern beschrieben zu installieren und zu betreiben. Des Weiteren dürfen auch nur von der IBM empfohlene Kabel angeschlossen werden. IBM übernimmt keine Verantwortung für die Einhaltung der Schutzanforderungen, wenn das Produkt ohne Zustimmung der IBM verändert bzw. wenn Erweiterungskomponenten von Fremdherstellern ohne Empfehlung der IBM gesteckt/eingebaut werden.

EN 55022 Klasse A Geräte müssen mit folgendem Warnhinweis versehen werden:

“Warnung: Dieses ist eine Einrichtung der Klasse A. Diese Einrichtung kann im Wohnbereich Funk-Störungen verursachen; in diesem Fall kann vom Betreiber verlangt werden, angemessene Maßnahmen zu ergreifen und dafür aufzukommen.”

### **Deutschland: Einhaltung des Gesetzes über die elektromagnetische Verträglichkeit von Geräten**

Dieses Produkt entspricht dem “Gesetz über die elektromagnetische Verträglichkeit von Geräten (EMVG).” Dies ist die Umsetzung der EU-Richtlinie 2004/108/EG in der Bundesrepublik Deutschland.

### **Zulassungsbescheinigung laut dem Deutschen Gesetz über die elektromagnetische Verträglichkeit von Geräten (EMVG) (bzw. der EMC EG Richtlinie 2004/108/EG) für Geräte der Klasse A**

Dieses Gerät ist berechtigt, in Übereinstimmung mit dem Deutschen EMVG das EG-Konformitätszeichen - CE - zu führen.

Verantwortlich für die Einhaltung der EMV Vorschriften ist der Hersteller:

International Business Machines Corp.  
New Orchard Road  
Armonk, New York 10504  
Tel: 914-499-1900

Der verantwortliche Ansprechpartner des Herstellers in der EU ist:

IBM Deutschland GmbH Technical Regulations, Abteilung M372 IBM-Allee 1, 71139 Ehningen, Germany Tele: +49 7

### **Generelle Informationen:**

**Das Gerät erfüllt die Schutzanforderungen nach EN 55024 und EN 55022 Klasse A.**

## People's Republic of China Class A Statement

### 中华人民共和国“A类”警告声明

#### 声明

此为A级产品，在生活环境中，该产品可能会造成无线电干扰。在这种情况下，可能需要用户对其干扰采取切实可行的措施。

## Taiwan Class A Statement

警告使用者：  
這是甲類的資訊產品，在居住的環境中使用時，可能會造成射頻干擾，在這種情況下，使用者會被要求採取某些適當的對策。

12c00790

## Taiwan Contact Information

This topic contains the product service contact information for Taiwan.

IBM Taiwan Product Service Contact Information:  
IBM Taiwan Corporation  
3F, No 7, Song Ren Rd., Taipei Taiwan  
Tel: 0800-016-888

台灣IBM 產品服務聯絡方式：  
台灣國際商業機器股份有限公司  
台北市松仁路7號3樓  
電話：0800-016-888

12c00790

## Japan Electronics and Information Technology Industries Association (JEITA) Notice

(一社) 電子情報技術産業協会 高調波電流抑制対策実施  
要領に基づく定格入力電力値： Knowledge Centerの各製品の  
仕様ページ参照

This statement applies to products less than or equal to 20 A per phase.

高調波電流規格 JIS C 61000-3-2 適合品

This statement applies to products greater than 20 A, single phase.

高調波電流規格 JIS C 61000-3-2 準用品

本装置は、「高圧又は特別高圧で受電する需要家の高調波抑制対策ガイドライン」対象機器（高調波発生機器）です。

- 回路分類：6（単相、PFC回路付）
- 換算係数：0

This statement applies to products greater than 20 A per phase, three-phase.

高調波電流規格 JIS C 61000-3-2 準用品

本装置は、「高圧又は特別高圧で受電する需要家の高調波抑制対策ガイドライン」対象機器（高調波発生機器）です。

- 回路分類：5（3相、PFC回路付）
- 換算係数：0

## Japan Voluntary Control Council for Interference (VCCI) Notice

This explains the Japan Voluntary Control Council for Interference (VCCI) statement.

この装置は、クラス A 情報技術装置です。この装置を家庭環境で使用する  
と電波妨害を引き起こすことがあります。この場合には使用者が適切な対策  
を講ずるよう要求されることがあります。 VCCI-A

## Korean Communications Commission Class A Statement

This explains the Korean Communications Commission (KCC) statement.

이 기기는 업무용(A급)으로 전자파적합기기로서 판매자 또는 사용자는 이 점을 주의하시기  
바라며, 가정외의 지역에서 사용하는 것을 목  
적으로 합니다.

## Russia Electromagnetic Interference Class A Statement

This statement explains the Russia Electromagnetic Interference (EMI) statement.

**ВНИМАНИЕ!** Настоящее изделие относится к классу А.  
В жилых помещениях оно может создавать  
радиопомехи, для снижения которых необходимы  
дополнительные меры

rusemi

---

### Homologation statement

This product may not be certified in your country for connection by any means whatsoever to interfaces of public telecommunications networks. Further certification may be required by law prior to making any such connection. Contact an IBM representative or reseller for any questions.







Part Number: 01YK739

EC: P18005K

SC27-4627-02



(1P) P/N: 01YK739

