

IBM IMS Database Reorganization Expert for  
z/OS  
4.1

*User's Guide*



**Note:**

Before using this information and the product it supports, read the information in [“Notices” on page 803.](#)

**13th Edition (July 2024)**

This edition applies to Version 4.1 of IBM IMS Database Reorganization Expert for z/OS (program number 5655-S35) and to all subsequent releases and modifications until otherwise indicated in new editions.

This edition replaces SC19-1137-11.

© **Copyright International Business Machines Corporation 2001, 2024.**

US Government Users Restricted Rights – Use, duplication or disclosure restricted by GSA ADP Schedule Contract with IBM Corp.

---

# Contents

- About this information..... xv**
  
- Part 1. Introduction to IMS Database Reorganization Expert.....1**
  - Chapter 1. IMS Database Reorganization Expert overview..... 3
    - What's new in IMS Database Reorganization Expert.....3
    - IMS Database Reorganization Expert terminology.....15
    - What is IMS Database Reorganization Expert?..... 17
    - IMS Database Reorganization Expert features and benefits..... 18
    - IMS Database Reorganization Expert environment and process flow.....21
    - IMS Database Reorganization Expert restrictions.....23
    - Functional changes..... 23
      - Changes in IMS Database Reorganization Expert 4.1..... 24
      - Changes in IMS Parallel Reorganization 3.2..... 27
      - Changes in IMS Parallel Reorganization 3.1..... 31
    - Service updates and support information..... 34
    - Product documentation and updates..... 34
    - Accessibility features..... 36
  
- Part 2. Installing and configuring IMS Database Reorganization Expert.....37**
  - Chapter 2. Installation overview..... 39
    - Hardware and software prerequisites..... 39
    - Migration considerations for IMS Parallel Reorganization users..... 40
      - Basic migration steps..... 40
      - Migration considerations for IMS Tools Online System Interface..... 41
      - Migration steps for using the Smart Reorg utility.....41
  
  - Chapter 3. Configuring the IMS Database Reorganization Expert environment..... 43
    - Task 1: Configuring Policy Services for the Smart Reorg utility..... 44
    - Task 2: Completing configuration for IMS Tools Knowledge Base..... 44
      - Task 2-1: Registering products and reports to IMS Tools KB.....44
      - Task 2-2: Defining RECON environments.....45
      - Task 2-3: Requesting utility jobs store reports to the IMS Tools KB repository..... 46
    - Task 3: Verifying product information registered to IMS Tools KB..... 46
    - Task 4: Verifying the CRSS environment.....47
    - Task 5: Setting up the DBRC environment.....47
      - Setting up the DBRC command authorization..... 47
      - Setting up the DBRC SCI registration exit routine..... 48
    - Task 6: Configuring Parallel Reorganization Service for the Smart Reorg utility..... 48
      - Setting up IMS Index Builder..... 49
      - Setting up for using E-MCS console for IMS command processing..... 50
    - Task 7: Setting default values for your runtime environment..... 51
  
- Part 3. Reorganizing a database in one job step..... 53**
  - Chapter 4. Smart Reorg utility..... 55
    - Smart Reorg overview..... 55
    - Programs and services used in Smart Reorg utility jobs..... 56
    - Process flow of the Smart Reorg utility.....57

Smart Reorg restrictions and requirements.....	58
Chapter 5. Conditional Reorganization Support Service.....	61
What is the Conditional Reorganization Support Service?.....	61
Data and process flow of the CRSS.....	62
Reorganization policy overview.....	64
What is a policy?.....	64
IBM-supplied policy and rule templates.....	64
Sensor data and data elements.....	65
Considerations for collecting sensor data from a database that is being updated.....	66
Chapter 6. Parallel Reorganization Service.....	69
What is Parallel Reorganization Service?.....	69
Reorganization tasks and IPRPIPE.....	72
Reorganization Manager.....	72
Prefix Resolution and update processing during reorganization.....	74
Image Copy processing and HASH pointer checking.....	74
Data and process flow of Parallel Reorganization Service.....	75
Chapter 7. Using the Smart Reorg utility.....	85
Running a job in Unconditional Reorganization mode.....	85
Running a job in Conditional Reorganization mode.....	86
Running a job in Reorganization Diagnosis mode.....	87
Running a job in Diagnosis-only mode.....	88
Chapter 8. Smart Reorg JCL requirements.....	89
EXEC statement.....	89
DD statements.....	90
DD names common to all processing options.....	95
DD names for the Unload task.....	99
DD names for the Reload task.....	99
DD names for the Index Builder task.....	101
DD names for logical relationship processing.....	102
DD names for Image Copy processing.....	102
DD names for HASH pointer check processing.....	103
Considerations for database data sets.....	104
Considerations for DBD libraries.....	108
Considerations for secondary indexes.....	108
Considerations for logical relationships.....	109
Considerations for Image Copy processing.....	110
Considerations for HASH pointer checking.....	114
Considerations for the IMS management of ACBs.....	115
Chapter 9. Smart Reorg control statements.....	117
Control statement syntax for the HPSIN data set.....	118
Control statements for the Smart Reorg Driver.....	118
ADDBGRP control statement.....	127
ADXCGRP control statement.....	127
AUTHFAIL control statement.....	128
CONDREORG control statement.....	128
CRIC control statement.....	130
CRUNLOAD control statement.....	130
DALUNIT control statement.....	131
DBRCAUTHCMD control statement.....	131
DBSHARE control statement.....	132
DDNMAP control statement.....	133
DECODEDBD control statement.....	133
DECODESXD control statement.....	134

DELOLDDS control statement.....	135
DISPOLDDS control statement.....	135
DYNALLOC control statement.....	136
HPIO control statement.....	137
IC control statement.....	138
ICNEEDED control statement.....	138
ICTYPE control statement.....	139
ILDSBLD control statement.....	139
IMSCMD control statement.....	140
IMSCMDOPT control statement.....	142
INDEXBLD control statement.....	143
ITKBDATA control statement.....	143
ITKBLOAD control statement.....	144
ITKBSRVR control statement.....	144
KEYLABELCHK control statement.....	145
LASTAUTHFLAG control statement.....	146
NAMESWAP control statement.....	147
NAMESWAPFAIL control statement.....	148
NEWDBD control statement.....	149
PARTITION control statement.....	150
PIPEBLKSZ control statement.....	151
PIPEDEPTH control statement.....	152
PIPEWAIT control statement.....	152
PREFIXRES control statement.....	153
PSINDEXBLD control statement.....	153
RC_CHANGE control statement.....	154
REORGINPUT control statement.....	155
SINDEXSUF control statement.....	156
SPACEALLOC control statement.....	156
STARTDB control statement.....	158
STATRL control statement.....	159
STATUL control statement.....	160
TOSITEST control statement.....	160
TOSIWAIT control statement.....	160
TOSIXCFGRP control statement.....	161
UNLOADONLY control statement.....	161
ZIIPMODE control statement.....	162
Control statements for the Conditional Reorganization Support Service.....	162
DBS_HPIO control statement.....	164
DIAGDATAFROM control statement.....	164
JOURNAL control statement.....	164
POLICYBY control statement.....	165
POLICYNM control statement.....	166
PRINTRPRT control statement.....	166
SENSOR_HOME control statement.....	166
STORERPRT control statement.....	167
Control statements for the Unload task.....	167
Control statements for the Reload task.....	170
Control statements for the Index Builder task.....	175
Control statements for the Prefix Resolution task.....	176
Control statements for the Image Copy task.....	177
Hints and tips for specifying control statements.....	178
Chapter 10. Smart Reorg examples.....	181
Example 1: Generating the Diagnosis report without reorganizing the database.....	181
Example 2: Conditionally reorganizing a database.....	182
Example 3: Reorganizing a database and generating the Diagnosis report.....	184
Example 4: Reorganizing a database without rebuilding indexes.....	184

Example 5: Reorganizing a database and its secondary indexes.....	185
Example 6: Reorganizing a database while allowing read access.....	186
Example 7: Reorganizing logically related databases.....	187
Example 8: Reorganizing a HALDB partition.....	187
Example 9: Taking an Image Copy while reorganizing a database.....	188
Example 9-1: Type-A Image Copy (1).....	188
Example 9-2: Type-A Image Copy (2).....	189
Example 9-3: Type-A Image Copy (3).....	190
Example 9-4: Type-A Image Copy (4).....	191
Example 9-5: Type-B Image Copy.....	192
Example 9-6: Type-A Image Copy for HALDB partitions.....	193
Example 10: Reorganizing and starting a database and indexes.....	195
Example 11: Reloading a database and taking an image copy.....	196
Example 12: Performing manual post-processing after a Smart Reorg utility job.....	197
Example 13: Reorganizing a HALDB database and rebuilding PSINDEXes.....	198
Example 14: Conditional reorganization based on the number of days since the last reorganization.....	199
Example 15: Reorganizing a database when the IMS management of ACBs is enabled.....	201
Example 16: Conditionally reorganizing a database in separate job steps.....	202
Chapter 11. Working with policies and database exceptions.....	205
Preparing a reorganization policy.....	205
Checking the policy evaluation summary message.....	205
Identifying the cause of database exceptions.....	206
Resolving database exceptions.....	207
Finding Diagnosis reports by using report completion codes.....	208
Chapter 12. Preparing and completing reorganization.....	211
Pre-reorganization processing.....	211
Post-reorganization processing.....	212
Performing manual name swapping.....	212
Performing manual DBRC notification processing.....	213
Performing manual image copy processing.....	214
Post-reorganization processing for database with logical relationships.....	214
Restarting the reorganized database.....	215
Chapter 13. Smart Reorg reports.....	217
Report reference for Smart Reorg.....	217
BBERPRT data set: Diagnosis report.....	221
Summary of Database Definition section.....	222
Summary of Policy Evaluation section.....	224
Database Record Statistics section.....	227
Randomizing Statistics section (HDAM and PHDAM).....	229
Physical I/O Statistics section.....	229
Volume and Extent Statistics section.....	230
Data Set Space Usage Statistics section.....	232
IMS Space Utilization Statistics section.....	233
KEYLABEL Statistics section.....	234
HISAM Statistics section (HISAM and SHISAM).....	234
Index Space Utilization Statistics section (HIDAM and PHIDAM).....	235
Volume and Extent Statistics section (Primary Index).....	237
Data Set Space Usage Statistics section (Primary Index).....	238
Index Statistics section (Primary Index).....	239
HPSOUT data set.....	240
Environment report.....	241
Default Option Tables report.....	241
HPSIN Control Statements report.....	242
HALDB Process Summary report.....	248

Segment Count Summary report (Unload task).....	250
Segment Count Summary report (Reload task).....	251
WFP Process Summary report (Reload task).....	253
HPSOUT2 data set.....	254
Decoded DBD report.....	255
Decoded New DBD report.....	256
DBRC Authorization Processing for Reorganization report.....	257
Result of Shadow Space Allocation report.....	257
Result of PSINDEX Copy report.....	259
Data Set Information report.....	259
DBRC Authorization Processing for Name Swapping report.....	262
Result of Name Swapping report.....	263
IDCAMS Command Stream for Name Swapping report.....	264
DBRC Notification Processing report.....	266
IDCAMS Command Stream for Recovery from Name Swap Error report.....	267
DBRC Notification Command Stream report.....	268
Result of Old Data Sets Deletion report.....	269
Result of Renaming Old Data Sets report.....	269
DBRC processing for restoring authorization flags.....	270
IMS Command Processing report.....	270
HPSLIST data set.....	271
HPSSSTAT data set.....	271
Data Set Statistics report.....	272
Segment Statistics report.....	275
Pointer Count Summary report.....	277
Pointer Statistics report.....	278
BBEJRNL data set.....	279
BSNJM01 data set.....	280
BBEERROR data set.....	280
SEQERROR data set.....	281
HPSTRACE data set.....	281
HPSSNAP data set.....	281
Reports produced by IMS Index Builder.....	282
Reports produced by IMS HP Prefix Resolution.....	282
Reports produced by IMS HP Image Copy.....	282
Reports produced by IMS HP Pointer Checker.....	282

## **Part 4. Reorganizing databases that have external logical relationships..... 285**

Chapter 14. Pre-reorganization utility and Post-reorganization utility.....	287
Pre-reorganization utility and Post-reorganization utility overview.....	287
Pre-reorganization utility functions.....	287
Post-reorganization utility functions.....	289
Process flow for reorganizing databases that have external logical relationships.....	291
Restrictions for the Pre-reorganization utility and the Post-reorganization utility.....	293
Chapter 15. Using the Pre-reorganization utility and Post-reorganization utility.....	295
Reorganizing databases that have external logical relationships.....	295
Result data sets.....	296
Cleaning up work data sets by using the Cleanup utility.....	296
Recovering from Post-reorganization utility errors.....	298
Chapter 16. Pre-reorganization utility JCL requirements.....	301
Chapter 17. Pre-reorganization utility control statements.....	305
Control statements for the (REORG) block.....	305
WORKHLQ control statement.....	310

WORKUNIT control statement.....	310
WORKVOL control statement.....	310
Control statements for the (PREFIXRES) block.....	311
Chapter 18. Post-reorganization utility JCL requirements.....	313
Chapter 19. Post-reorganization utility control statements.....	319
Control statements for the Image Copy task.....	319
Control statements that affect HASH pointer checking.....	321
Considerations for database data sets.....	322
Chapter 20. JCL considerations for the Smart Reorg utility and the IPR DB Scan utility.....	325
Smart Reorg utility JCL considerations (after running the Pre-reorganization utility).....	325
IPR DB Scan utility JCL considerations (after running the Pre-reorganization utility).....	326
Chapter 21. Pre-reorganization utility and Post-reorganization utility JCL examples.....	327
Example 1: Reorganizing a database in a logical group.....	327
Example 2: Reorganizing all databases in a logical group.....	330
Chapter 22. Pre-reorganization utility and Post-reorganization utility reports.....	335
Pre-reorganization utility reports.....	335
HPSOUT data set (Pre-reorganization utility).....	336
HPSOUT2 data set (Pre-reorganization utility).....	339
Post-reorganization utility reports.....	340
HPSOUT data set (Post-reorganization utility).....	342
HPSOUT2 data set (Post-reorganization utility).....	342
<b>Part 5. Unloading a database.....</b>	<b>349</b>
Chapter 23. IPR Unload utility.....	351
IPR Unload overview.....	351
IPR Unload features.....	351
Data flow for IPR Unload.....	353
IPR Unload restrictions and considerations.....	354
Chapter 24. Running an unload job.....	357
Unloading a database.....	357
Unloading a damaged database.....	357
Chapter 25. IPR Unload JCL requirements.....	359
EXEC statement.....	359
DD statements.....	360
Using JCL for IMS HD Reorganization Unload.....	364
Steps to run the JCL for IMS HD Reorganization Unload.....	364
EXEC statement and DD statements.....	365
Restrictions.....	366
Chapter 26. IPR Unload control statements.....	367
Syntax for the IPR Unload control statements.....	367
Control statements for the unload function.....	367
CHECKREC control statement.....	370
DBRECDIST control statement.....	370
DBRECKEYS control statement.....	371
DECODEDBD control statement.....	371
DECOMPRESS control statement.....	372
FALLBACK control statement.....	372
HOMECHK control statement.....	373



ITKBLOAD control statement.....	373
ITKBSRVR control statement.....	374
MIGRATE control statement.....	375
OUTPUT control statement.....	375
PARTITION control statement.....	383
PROGMON control statement.....	384
RAPCHECK control statement.....	385
SEGSEL control statement.....	385
SKIPAUTH control statement.....	386
STATREP control statement.....	386
USERHDR control statement.....	387
Control statements for HSSR Engine.....	389
BLDLPCK control statement.....	392
BUFFERS control statement.....	392
BUFSTAT control statement.....	395
BYINDEX control statement.....	395
CABBASE control statement.....	396
COMPAREDLI control statement.....	397
COMPAUTH control statement.....	398
DATXEXIT control statement.....	398
DBSTATS control statement.....	398
DIAGG control statement.....	399
KEYCHECK control statement.....	400
LOUT control statement.....	400
PARTINFO control statement.....	401
PARTSTAT control statement.....	401
RTEXTIT control statement.....	402
SKIPERROR control statement.....	402
TRACE control statement.....	403
ZIIPMODE control statement.....	404
Chapter 27. IPR Unload JCL examples.....	405
Example 1: Unloading an IMS database.....	405
Example 2: Unloading a partition of a HALDB.....	405
Example 3: Unloading a damaged database.....	406
Example 4: Unloading using JCL for IMS HD Reorganization Unload.....	406
Example 5: Unloading a database in an IMS-managed ACBs environment.....	407
Example 6: Unloading a database with the IMS Catalog Definition exit routine.....	407
Chapter 28. IPR Unload reports.....	409
Report reference table for IPR Unload.....	409
Environment report.....	412
Default Option Tables report.....	414
HPSIN Control Statements report.....	414
Decoded DBD report.....	416
DBD Summary report.....	416
HALDB Partitions Processed report.....	421
Segment Count Summary report.....	421
Segment Statistics report.....	428
HDAM Root Addressable Area Statistics report.....	435
HDAM RAP Chain I/O Summary report.....	439
Distribution of Database Record Sizes report.....	442
Largest Database Records report.....	443
HISAM Statistics report.....	443
Data Set Statistics report.....	444
Buffering and I/O Statistics report.....	447
HALDB Partition Definition report.....	451
HDAM RAPCHECK Incorrect RAP Chain report.....	452

Chapter 29. User exits for IPR Unload.....	455
Type-A user exit.....	455
Type-B user exit.....	456
Chapter 30. Application programming interface for IPR Unload utility.....	461
Overview.....	461
HSSR application program.....	461
Application program that can benefit from HSSR Engine.....	461
Preparing and running application program.....	462
Selecting a region type.....	462
Preparing a PSB.....	462
Coding DL/I calls and EXEC DLI commands for HSSR PCB.....	464
Creating the application program.....	466
Specifying an HSSR PCB.....	466
System flow of the API function.....	467
PCB feedback information.....	467
Interpreting PCB feedback.....	467
Status codes.....	469
Restrictions.....	471
JCL requirements.....	472
EXEC statement.....	472
DD statements.....	472
Control statements for the API function.....	474
APISET control statement.....	475
PCB and PCBNAME control statements.....	475
PCBLIST control statement.....	475
Control statements for HSSR Engine.....	476
JCL examples for the API function.....	476
Example 1: Running an HSSR application program.....	476
Example 2: Running an HSSR application program in an IMS-managed ACBs environment....	477
Example 3: Running an HSSR application program with the IMS Catalog Definition exit routine.....	478
Reports and statistics produced by the API function.....	478
Compatibility considerations.....	479
Chapter 31. Tips for unloading damaged databases.....	481
Using SKIPERROR to unload damaged databases.....	481
Rules for unloading with the SKIPERROR option.....	481
<b>Part 6. Reloading a database.....</b>	<b>483</b>
Chapter 32. IPR Reload utility.....	485
IPR Reload overview.....	485
IPR Reload features.....	485
Data flow for IPR Reload.....	486
IPR Reload compatibility with other utilities.....	487
IPR Reload restrictions.....	488
Chapter 33. Reorganizing a HALDB.....	489
Job steps.....	489
Reorganizing partitions individually.....	490
Chapter 34. IPR Reload JCL requirements.....	491
Chapter 35. IPR Reload control statements.....	501
Syntax for the IPR Reload control statements.....	502

Overview of the IPR Reload control statements.....	502
BMSETDSG control statement.....	509
BUFFERNO control statement.....	510
BYTELIMIT control statement.....	510
CHKEMPTYUL control statement.....	511
CHKTRAIL control statement.....	511
CHKUPDT control statement.....	512
COMPAUTH control statement.....	512
COMPRESS control statement.....	513
DATXEXIT control statement.....	513
DBDSNAP control statement.....	514
DBIOBUF control statement.....	514
DBRECDIST control statement.....	515
DBRLBUF control statement.....	516
DECODEDBD control statement.....	516
EXTENT control statement.....	516
FRSPC control statement.....	517
GDGBASE control statement.....	517
GDGLIMIT control statement.....	517
HPIO control statement.....	518
ILDSBLD control statement.....	518
ILEDATAC control statement.....	519
ILESTORC control statement.....	519
INPUT control statement.....	520
ITKBLOAD control statement.....	520
ITKBSRVR control statement.....	521
LPART control statement.....	522
OADSPR control statement.....	523
PAD control statement.....	523
PARTINFO control statement.....	524
PARTINIT control statement.....	524
PROGMON control statement.....	525
RAAFORMAT control statement.....	525
RAPCHAIN control statement.....	526
RECNUM control statement.....	526
REPAIRILK control statement.....	526
RMBSEGSZ control statement.....	527
SEARCH control statement.....	527
SEQERROR control statement.....	527
SORT control statement.....	528
SORTHIDAM control statement.....	530
TWINSTAT control statement.....	530
USERHDR control statement.....	531
USERHDRX control statement.....	532
WF1DSN control statement.....	533
WF1REC control statement.....	533
WF1SPACE control statement.....	533
WF1UNIT control statement.....	534
WF1VOL control statement.....	534
WFPHLQ control statement.....	534
WFPSPACE control statement.....	535
WFPUNIT control statement.....	535
WFPVOL control statement.....	535
WFPVOLCNT control statement.....	536
ZIIPMODE control statement.....	536
Chapter 36. IPR Reload JCL examples.....	537
Example 1: As a part of the reorganization process.....	537

Example 2: Creating an empty database.....	538
Example 3: Reloading a database in an IMS-managed ACBs environment.....	538
Example 4: Reloading a database with the IMS Catalog Definition exit routine.....	539
<b>Chapter 37. IPR Reload reports.....</b>	<b>541</b>
HPSOUT data set.....	541
Environment report.....	542
Default Option Tables report.....	544
HPSIN Control Statements report.....	544
Decoded DBD report.....	546
DBD Summary report.....	547
Messages report.....	551
HALDB Partitions Processed report.....	552
Segment Count Summary report.....	552
Segment Statistics report.....	554
HDAM Root Addressable Area Statistics report.....	560
Distribution of Database Record Sizes report.....	563
HISAM Statistics report.....	565
Data Set Statistics report.....	565
I/O Statistics report.....	572
Pointer Count Summary report.....	573
Pointer Statistics report.....	574
WFP Process Summary report.....	575
HALDB Partition Definition report.....	576
DBRC Messages report.....	577
GDG Base Information report.....	577
HPSSNAP data set: DBD Snap report.....	578
<b>Chapter 38. User exits for IPR Reload.....</b>	<b>579</b>
User exit interface.....	579
Register contents upon entry to the user exit.....	580
Register contents upon return from the user exit.....	581
Considerations for using Enterprise COBOL for z/OS program user exit.....	581
Considerations for using Enterprise PL/I for z/OS program user exit.....	582
Sample user exits.....	582
<b>Part 7. Scanning a database to resolve logical relationships.....</b>	<b>583</b>
<b>Chapter 39. IPR DB Scan utility.....</b>	<b>585</b>
IPR DB Scan overview.....	585
Data flow for IPR DB Scan.....	585
IPR DB Scan restrictions and considerations.....	586
<b>Chapter 40. IPR DB Scan JCL requirements.....</b>	<b>587</b>
<b>Chapter 41. IPR DB Scan control statements.....</b>	<b>591</b>
Overview of IPR DB Scan control statements.....	592
ABEND control statement.....	592
ADDBGRP control statement.....	593
ADXCGRP control statement.....	593
DBS control statement.....	593
LOGREL control statement.....	594
OUTREC control statement.....	594
PROGMON control statement.....	595
<b>Chapter 42. IPR DB Scan JCL examples.....</b>	<b>597</b>
IPR DB Scan example: Case 1.....	597

IPR DB Scan example: Case 2.....	597
IPR DB Scan example: Case 3.....	598
IPR DB Scan example: Case 4.....	598
Chapter 43. IPR DB Scan reports.....	601
HPSIN Control Statements report.....	602
Logical Relationship Summary report.....	602
Output Record Summary report.....	605
Buffering and I/O Statistics report.....	606
<b>Part 8. Reference.....</b>	<b>607</b>
Chapter 44. Performance tips and considerations.....	609
Performance tips for the Smart Reorg utility.....	609
Performance tips for the IPR Unload utility.....	612
Performance tips for the IPR Reload utility.....	614
Chapter 45. Setting installation default options.....	617
How runtime options are determined.....	617
Creating an Installation Default Option Table (HPSCOPTI).....	617
HPSCOPTG sample JCL stream.....	618
How to code HPSCOPT macro statements.....	618
HPSCOPT macro statement examples.....	625
Chapter 46. Database tuning guide.....	629
Reports for database tuning.....	629
Working on exceptions in an HDAM database.....	631
Average number of I/O operations per database record.....	631
Tuning a randomizer.....	632
Tuning HDAM database that have long database records.....	642
Working on exceptions in a HIDAM database.....	644
Average number of I/O operations per database record.....	644
Is there enough free space defined in DBDGEN?.....	644
Is the block size or CI size appropriate?.....	645
Is the problem with long database records solved appropriately?.....	645
Working on exceptions in a HISAM or SHISAM database.....	646
Average number of I/O operations per database record.....	646
Is the length of the KSDS record appropriate?.....	647
Is the ESDS CI size appropriate for the record length of this database?.....	648
Does the segment fit on KSDS?.....	649
Working on space shortage exceptions.....	649
Chapter 47. How to read syntax diagrams.....	651
<b>Part 9. Troubleshooting.....</b>	<b>653</b>
Chapter 48. Problem determination.....	655
Identifying problems in Smart Reorg jobs.....	655
Identifying problems in Pre-reorganization utility and Post-reorganization utility jobs.....	656
Identifying problems in IPR Unload jobs.....	657
Identifying problems in IPR Reload jobs.....	657
Identifying problems in IPR DB Scan jobs.....	658
Gathering diagnostic information.....	658
Chapter 49. Messages and codes.....	661
Return codes.....	661
Smart Reorg utility return codes.....	661

Pre-reorganization utility, Post-reorganization utility, and Cleanup utility return codes.....	661
IPR Unload utility return codes.....	662
IPR Reload utility return codes.....	663
IPR DB Scan utility return codes.....	664
Abend codes.....	664
Messages.....	665
BBE messages.....	666
HPSC messages.....	695
HPSG messages.....	700
HPSR messages.....	765
HPSS messages.....	765
HPSU messages.....	768
Chapter 50. Diagnostics Aid.....	795
How to run Diagnostics Aid with JCL stream.....	795
Diagnostics Aid reports.....	796
IMS Database Reorganization Expert Load Module APAR Status report.....	796
IMS Database Reorganization Expert Macro APAR Status report.....	797
Diagnostic messages and codes.....	797
Return codes.....	797
Abend codes.....	797
Messages.....	797
<b>Notices.....</b>	<b>803</b>
<b>Index.....</b>	<b>807</b>

## About this information

---

IBM® IMS Database Reorganization Expert for z/OS® (also referred to as IMS Database Reorganization Expert) helps you simplify the reorganization of IMS full-function databases.

These topics provide instructions for installing, configuring, and using IMS Database Reorganization Expert.

These topics are for people performing the task of IMS database administration, as it relates to the IMS Database Reorganization Expert. The task of database administration is to design, implement, and maintain databases.

These topics are designed to help database administrators, computer operators, system programmers, application programmers, and system analysts perform these tasks:

- Understand the functions of IMS Database Reorganization Expert
- Run and use IMS Database Reorganization Expert after it is installed
- Use DD statements to control how you use IMS Database Reorganization Expert
- Use IMS Database Reorganization Expert reports
- Understand and recover from IMS Database Reorganization Expert problems

To use these topics, you should have a working knowledge of:

- The z/OS operating system
- ISPF
- SMP/E

Always refer to the IMS Tools Product Documentation web page for complete product documentation resources:

<https://www.ibm.com/support/pages/node/712955>

The IMS Tools Product Documentation web page includes:

- Links to [IBM Documentation](#) for the user guides ("HTML")
- PDF versions of the user guides ("PDF")
- Program Directories for IMS Tools products
- Technical notes from IBM Software Support, referred to as "Tech notes"
- White papers that describe product business scenarios and solutions





---

# Part 1. Introduction to IMS Database Reorganization Expert

The following topic introduces IBM IMS Database Reorganization Expert for z/OS (also referred to as IMS Database Reorganization Expert).

**Topics:**

- [Chapter 1, “IMS Database Reorganization Expert overview,” on page 3](#)



---

# Chapter 1. IMS Database Reorganization Expert overview

The following topics provide an overview of the features of IMS Database Reorganization Expert.

## Topics:

- [“What's new in IMS Database Reorganization Expert” on page 3](#)
- [“IMS Database Reorganization Expert terminology” on page 15](#)
- [“What is IMS Database Reorganization Expert?” on page 17](#)
- [“IMS Database Reorganization Expert features and benefits” on page 18](#)
- [“IMS Database Reorganization Expert environment and process flow” on page 21](#)
- [“IMS Database Reorganization Expert restrictions” on page 23](#)
- [“Functional changes” on page 23](#)
- [“Service updates and support information” on page 34](#)
- [“Product documentation and updates” on page 34](#)
- [“Accessibility features” on page 36](#)

---

## What's new in IMS Database Reorganization Expert

This topic summarizes the technical changes for this edition.

New and changed information is indicated by a vertical bar (|) to the left of a change. Editorial changes that have no technical significance are not noted.

Revision markers follow these general conventions:

- Only technical changes are marked; style and grammatical changes are not marked.
- If part of an element, such as a paragraph, syntax diagram, list item, task step, or figure is changed, the entire element is marked with revision markers, even though only part of the element might have changed.
- If a topic is changed by more than 50%, the entire topic is marked with revision markers (so it might seem to be a new topic, even though it is not).

Revision markers do not necessarily indicate all the changes made to the information because deleted text and graphics cannot be marked with revision markers.

For more information about functional enhancements, see [“Changes in IMS Database Reorganization Expert 4.1” on page 24](#).

## SC19-1137-12 (July 2024)

Description	Related APARs
<p>(Smart Reorg utility) Key label check support. Use the KEYLABELCHK statement to check whether the key labels of database data sets match the key labels defined in the RACF data set profile or SMS data class. If the key labels are different, the CRSS determines that the database requires reorganization. The following topics are added or modified:</p> <ul style="list-style-type: none"><li>• <a href="#">“DD statements” on page 90</a></li><li>• <a href="#">“DD names common to all processing options” on page 95</a></li><li>• <a href="#">“Control statements for the Smart Reorg Driver” on page 118</a></li><li>• <a href="#">“KEYLABELCHK control statement” on page 145</a></li><li>• <a href="#">“SPACEALLOC control statement” on page 156</a></li><li>• <a href="#">“Report reference for Smart Reorg” on page 217</a></li><li>• <a href="#">“BBERPRT data set: Diagnosis report” on page 221</a></li><li>• <a href="#">“KEYLABEL Statistics section” on page 234</a></li><li>• <a href="#">“Default Option Tables report” on page 241</a></li><li>• <a href="#">“HPSIN Control Statements report” on page 242</a></li><li>• <a href="#">“BBEERROR data set” on page 280</a></li><li>• <a href="#">“How to code HPSCOPT macro statements” on page 618</a></li><li>• New messages: BBE0218I, BBE0219E, HPSG0460E</li></ul>	PH59280

## SC19-1137-11 (June 2024)

Description	Related APARs
<p>To support the enhancement made by IMS APAR PH53287 (read STAGING option from SYSIN), description about the SYSIN DD statement is added to <a href="#">Chapter 34, “IPR Reload JCL requirements,” on page 491</a>.</p>	N/A

## SC19-1137-10 (April 2024)

Description	Related APARs
<p>Added message HPSC3722E.</p>	PH60605

## SC19-1137-09 (November 2022)

Description	Related APARs
(Smart Reorg utility) Support for the following new control statements: <ul style="list-style-type: none"><li>• CRIC control statement: Creates image copies of all database data sets or HALDB partitions even when the Conditional Reorganization Support Service (CRSS) determines that reorganization of the entire database or some partitions are not needed.</li><li>• CRUNLOAD control statement: Creates an unload data set that contains data from the database or HALDB partitions. You can choose to create an unload data set only when the CRSS determines that reorganization is needed or every time the job is run (regardless of whether reorganization is needed).</li></ul> The following topics are added or modified: <ul style="list-style-type: none"><li>• <a href="#">“Changes in IMS Database Reorganization Expert 4.1”</a> on page 24</li><li>• <a href="#">“Data and process flow of Parallel Reorganization Service”</a> on page 75</li><li>• <a href="#">“Considerations for Image Copy processing”</a> on page 110</li><li>• <a href="#">“Control statements for the Smart Reorg Driver”</a> on page 118</li><li>• <a href="#">“CRIC control statement”</a> on page 130</li><li>• <a href="#">“CRUNLOAD control statement”</a> on page 130</li><li>• <a href="#">“DBRCAUTHCMD control statement”</a> on page 131</li><li>• <a href="#">“IMSCMD control statement”</a> on page 140</li><li>• <a href="#">“UNLOADONLY control statement”</a> on page 161</li><li>• <a href="#">“Control statements for the Unload task”</a> on page 167</li><li>• <a href="#">“HPSIN Control Statements report”</a> on page 242</li><li>• <a href="#">“Data Set Information report”</a> on page 259</li><li>• New and changed messages: HPSG0033I, HPSG0034I, HPSG0102E, HPSG0245E, HPSG0351I, HPSG0352I, HPSG0395E, HPSG3205E, HPSG3206E, HPSU3161E</li></ul>	PH41443

## SC19-1137-08 (May 2022)

Description	Related APARs
Updated the explanation section and the system action section of message BBE1323I.	N/A
Updated topic <a href="#">“Processing option (PROCOPT) requirements”</a> on page 463.	N/A

## SC19-1137-07 (August 2021)

Description	Related APARs
(Smart Reorg utility) A new parameter, FORCE, is supported for the STARTDB control statement. The following topics are modified: <ul style="list-style-type: none"><li>• <a href="#">“AUTHFAIL control statement”</a> on page 128</li><li>• <a href="#">“STARTDB control statement”</a> on page 158</li><li>• New message: HPSG2108I</li></ul>	PH36650

Description	Related APARs
(DB Sensor) OSAM encryption support. Changed messages: HPSG2313W, BBE1444E	PH35209 and PH29916
(Smart Reorg utility) Changed messages: HPSG0306E, HPSG0307E	PH35323
Support for IMS OSAM database enhancements. The following topics are modified:	PH26055
<ul style="list-style-type: none"> <li>• <a href="#">“DYNALLOC control statement” on page 136</a></li> <li>• <a href="#">“SPACEALLOC control statement” on page 156</a></li> <li>• <a href="#">“Control statements for the Reload task” on page 170</a></li> <li>• <a href="#">“Result of Shadow Space Allocation report” on page 257</a></li> <li>• <a href="#">“Result of Old Data Sets Deletion report” on page 269</a></li> <li>• <a href="#">“Result of Old Data Sets Deletion report (Post-reorganization utility)” on page 346</a></li> <li>• <a href="#">“BUFFERS control statement” on page 392</a></li> <li>• <a href="#">“CABBASE control statement” on page 396</a></li> <li>• <a href="#">“ZIIPMODE control statement” on page 404</a></li> <li>• <a href="#">Chapter 34, “IPR Reload JCL requirements,” on page 491</a></li> <li>• <a href="#">“DBIOBUF control statement” on page 514</a></li> <li>• <a href="#">“ILDSBLD control statement” on page 518</a></li> <li>• <a href="#">“Performance tips for the Smart Reorg utility” on page 609</a></li> <li>• <a href="#">“Performance tips for the IPR Unload utility” on page 612</a></li> <li>• <a href="#">“Performance tips for the IPR Reload utility” on page 614</a></li> <li>• Changed message: HPSG0111E</li> </ul>	
(Smart Reorg utility) Reporting result of renaming old data sets: The Result of Renaming Old Data Sets report contains result of renaming old (original) data sets with IDCAMS commands. The following topics are modified:	PH25042 and PH26788
<ul style="list-style-type: none"> <li>• <a href="#">“Result of Old Data Sets Deletion report” on page 269</a></li> <li>• <a href="#">“Result of Renaming Old Data Sets report” on page 269</a></li> <li>• New and changed messages: HPSG0451W and HPSG0459W</li> </ul>	
(Smart Reorg utility) DDEFPS2 DD statement for IDCAMS commands: Use the DDEFPS2 DD statement to point to a data set containing IDCAMS commands for deleting and allocating shadow data sets. The following topics are modified:	PH13318 and PH15942
<ul style="list-style-type: none"> <li>• <a href="#">“DD statements” on page 90</a></li> <li>• <a href="#">“DD names common to all processing options” on page 95</a></li> <li>• <a href="#">“Considerations for database data sets” on page 104</a></li> <li>• <a href="#">“DISPOLDDS control statement” on page 135</a></li> <li>• <a href="#">“DYNALLOC control statement” on page 136</a></li> <li>• <a href="#">“SPACEALLOC control statement” on page 156</a></li> <li>• New and changed messages: HPSG0111E, HPSG0457I, HPSG0458I</li> </ul>	

Description	Related APARs
<p>(Smart Reorg utility) Support conditional unload: The Smart Reorg utility can unload the database without reorganizing it. It can also pass a specific return code to the succeeding job step so that the database is reorganized in the succeeding job step. For more information, see the following topics:</p> <ul style="list-style-type: none"> <li>• <a href="#">“What is the Conditional Reorganization Support Service?”</a> on page 61</li> <li>• <a href="#">“CONDREORG control statement”</a> on page 128</li> <li>• <a href="#">“RC_CHANGE control statement”</a> on page 154</li> <li>• <a href="#">“STARTDB control statement”</a> on page 158</li> <li>• <a href="#">“UNLOADONLY control statement”</a> on page 161</li> <li>• <a href="#">“Control statements for the Unload task”</a> on page 167</li> <li>• <a href="#">“Example 16: Conditionally reorganizing a database in separate job steps”</a> on page 202</li> <li>• New and changed messages: HPSG0010W, HPSG0111E, HPSG0253E, HPSG0456W, HPSG2319I</li> </ul>	PH12332
<p>(DB Sensor) Encrypted VSAM ESDS database data sets support. Restriction item added to <a href="#">“SPACEALLOC control statement”</a> on page 156.</p>	PH11511
<p>(IPR Reload utility) EXTENT control statement enhancement: The default value for the EXTENT control statement is changed to 120. Also, the default value for the EXTENT control statement can be specified in the Installation Default Option Table (HPSCOPTI). The following topics are modified:</p> <ul style="list-style-type: none"> <li>• <a href="#">“Control statements for the Reload task”</a> on page 170</li> <li>• <a href="#">“Overview of the IPR Reload control statements”</a> on page 502</li> <li>• <a href="#">“EXTENT control statement”</a> on page 516</li> <li>• <a href="#">“Default Option Tables report”</a> on page 544</li> <li>• <a href="#">“How to code HPSCOPT macro statements”</a> on page 618</li> </ul>	PH11352
<p>(Smart Reorg utility) Ability to specify the access intent of the database: The STARTDB control statement supports new parameters, which you can use to specify the access intent of the database after post-reorganization processing. For more information, see <a href="#">“STARTDB control statement”</a> on page 158.</p> <p>New message: HPSG0252E</p>	PH09434
<p>(IPR Unload utility) Reporting of twin chained segments: The Segment Statistics report contains Twin Segment Statistics section, which provides statistics about twin chained segments. For more information, see <a href="#">“Segment Statistics report”</a> on page 428.</p>	PH07025
<p>(Smart Reorg utility) Information about how to avoid data set allocation failures when the HPSGAMSA data set contains many IDCAMS ALLOCATE commands is added to <a href="#">“SPACEALLOC control statement”</a> on page 156. Also, message HPSG0102E is updated.</p>	N/A

## SC19-1137-06 (January 2019)

Description	Related APARs
<p>(Smart Reorg utility) IMS management of ACBs support: The Smart Reorg utility was enhanced so that it can refer to database definitions in the IMS catalog instead of DBD libraries when the IMS management of ACBs is enabled. For more information, see the following topics:</p> <ul style="list-style-type: none"><li>• <a href="#">“Considerations for the IMS management of ACBs” on page 115</a></li><li>• <a href="#">“Example 15: Reorganizing a database when the IMS management of ACBs is enabled” on page 201</a></li></ul>	PH04969
<p>zIIP support: IMS Database Reorganization Expert supports IBM z Integrated Information Processor (zIIP) to offload eligible workloads to zIIP processors. To enable zIIP support, the following APARs must also be applied:</p> <ul style="list-style-type: none"><li>• APAR PI89050 for IMS HP Unload 1.2</li><li>• APAR PI88156 for IMS HP Load 2.1</li></ul> <p>For more information, see the following topics:</p> <ul style="list-style-type: none"><li>• (Smart Reorg utility) <a href="#">“ZIIPMODE control statement” on page 162</a></li><li>• (IPR Unload utility) <a href="#">“ZIIPMODE control statement” on page 404</a></li><li>• (IPR Reload utility) <a href="#">“ZIIPMODE control statement” on page 536</a></li></ul>	PI88158
<p>(IPR Unload utility) IMS management of ACBs support: The IPR Unload utility can refer to database definitions in the IMS catalog instead of DBD libraries when the IMS management of ACBs is enabled. For more information, see the following topics:</p> <ul style="list-style-type: none"><li>• <a href="#">“Example 5: Unloading a database in an IMS-managed ACBs environment” on page 407</a></li><li>• <a href="#">“Example 6: Unloading a database with the IMS Catalog Definition exit routine” on page 407</a></li><li>• (IPR Unload API) <a href="#">“Example 2: Running an HSSR application program in an IMS-managed ACBs environment” on page 477</a></li><li>• (IPR Unload API) <a href="#">“Example 3: Running an HSSR application program with the IMS Catalog Definition exit routine” on page 478</a></li></ul> <p>(IPR DB Scan utility) IMS management of ACBs support: The IPR DB Scan utility can refer to database definitions in the IMS catalog instead of DBD libraries when the IMS management of ACBs is enabled. For more information, see the following topics:</p> <ul style="list-style-type: none"><li>• <a href="#">“IPR DB Scan example: Case 3” on page 598</a></li><li>• <a href="#">“IPR DB Scan example: Case 4” on page 598</a></li></ul>	PI83671
<p>(Smart Reorg utility) Build PSINDEXes in HALDB reorganization jobs: The Smart Reorg utility supports building PSINDEXes when it reorganizes all the partitions of a HALDB. By this APAR, the Smart Reorg utility has been enhanced to support building of PSINDEXes even when some partitions of the HALDB are reorganized. For more information, see <a href="#">“PSINDEXBLD control statement” on page 153</a>.</p>	PI81313
<p>(Smart Reorg utility) DBD change support after Pre-reorganization utility jobs: The Smart Reorg utility has been enhanced to support running Smart Reorg utility jobs with a NEWDBD control statement after Pre-reorganization utility jobs. For more information, see <a href="#">“Smart Reorg utility JCL considerations (after running the Pre-reorganization utility)” on page 325</a>.</p>	PI80066



Description	Related APARs
<p>(IPR Reload utility) IMS management of ACBs support: The IPR Reload utility can refer to database definitions in the IMS catalog instead of DBD libraries when the IMS management of ACBs is enabled. For more information, see the following topics:</p> <ul style="list-style-type: none"> <li>• <a href="#">“Example 3: Reloading a database in an IMS-managed ACBs environment” on page 538</a></li> <li>• <a href="#">“Example 4: Reloading a database with the IMS Catalog Definition exit routine” on page 539</a></li> </ul>	PI79464
<p>(IPR Unload utility) CABBASE statement: The IPR Unload utility supports a new control statement, CABBASE. This statement specifies the basic size of I/O buffers that the CAB buffer handler allocates. For more information, see <a href="#">“CABBASE control statement” on page 396</a>.</p>	PI77308
<p>IMS 15 support: IMS Database Reorganization Expert supports IMS 15. To use IMS Database Reorganization Expert with IMS 15, the following APARs are also required for the related products:</p> <ul style="list-style-type: none"> <li>• APAR PI73493 for IMS HP Unload 1.2</li> <li>• APAR PI73050 for IMS HP Load 2.1</li> <li>• APAR PI73092 for IMS Index Builder 3.1</li> <li>• APAR PI73293 for IMS HP Image Copy 4.2</li> <li>• APAR PI73091 for IMS HP Prefix Resolution 3.1</li> <li>• APAR PI73056 for IMS HP Pointer Checker 3.1</li> <li>• APAR PI73057 for IMS Library Integrity Utilities 2.2</li> <li>• APAR PI72067 for IMS Tools Base 1.6</li> </ul>	PI73196
<p>(IPR Reload utility) New parameter for ILDSBLD statement: The IPR Reload utility supports a new parameter, YES,COND, for the ILDSBLD control statement, which specifies to build the Indirect List data sets (ILDSs) for the HALDB in the Smart Reorg job step. This parameter applies either YES,DSPR or YES,INITONLY depending on the condition. For more information, see <a href="#">“ILDSBLD control statement” on page 518</a>.</p>	PI69221
<p>(Smart Reorg utility) New parameter for ILDSBLD statement: The Smart Reorg utility supports a new parameter, YES,COND, for the ILDSBLD control statement, which specifies to build the Indirect List data sets (ILDSs) for the HALDB in the Smart Reorg job step. This parameter applies either YES,DSPR or YES,INITONLY depending on the condition. For more information, see <a href="#">“ILDSBLD control statement” on page 139</a>.</p>	PI68964
<p>(Smart Reorg utility) TOSITEST statement: The Smart Reorg utility supports a new control statement, TOSITEST. This statement specifies to wait for a certain amount of time for BMPs and MPPs to end before issuing IMS /DBD and /DBR commands. For more information, see <a href="#">“TOSITEST control statement” on page 160</a>.</p>	PI68510
<p>(IPR Unload utility) HPSRAPC DD statement: The IPR Unload utility supports a new DD statement, HPSRAPC DD. This DD statement defines the output data set for writing the check report when the RAPCHECK option is enabled for the Unload task. For more information, see <a href="#">“DD names for the Unload task” on page 99</a>.</p>	PI65915
<ul style="list-style-type: none"> <li>• Tips to improve the performance of IMS Database Reorganization Expert jobs are added. See <a href="#">Chapter 44, “Performance tips and considerations,” on page 609</a>.</li> <li>• JCL examples for the API function of the IPR Unload utility are added. See <a href="#">“JCL examples for the API function” on page 476</a>.</li> </ul>	N/A

## SC19-1137-05 (September 2016)

Description	Related APARs
<p>(Smart Reorg utility) HALDB multiple partition support for CRSS: The CRSS can process multiple partitions of a HALDB. If you specify CONDREORG=YES, the CRSS diagnoses all the partitions and the Smart Reorg utility reorganizes only the partitions that require reorganization. Also you can use the PARTITION control statement to specify non-sequential partitions. For more information, see the following topics:</p> <ul style="list-style-type: none"><li>• <a href="#">“CONDREORG control statement” on page 128</a></li><li>• <a href="#">“PARTITION control statement” on page 150</a></li></ul>	PI64268
<p>Option to call the segment compression exit in supervisor state: Use the new COMPAUTH control statement to call the segment compression exit in supervisor state. The COMPAUTH control statement is supported for the IPR Unload utility (HSSR Engine) and the IPR Reload utility and can be enabled in jobs of the Smart Reorg utility, IPR Unload utility, IPR Reload utility, and the IPR DB Scan utility. For more information, see the following topics:</p> <ul style="list-style-type: none"><li>• (IPR Unload utility) <a href="#">“COMPAUTH control statement” on page 398</a></li><li>• (IPR Reload utility) <a href="#">“COMPAUTH control statement” on page 512</a></li></ul>	PI52760
<p>(IPR Reload utility) PHIDAM database sorting before reload: If you use the SORTHIDAM control statement, the IPR Reload utility sorts the unloaded data before loading it into the database. For more information, see <a href="#">“SORTHIDAM control statement” on page 530</a>.</p>	PI50574
<p>(Smart Reorg utility) PIPEWAIT control statement enabled for installation default option: If you set the default value for the PIPEWAIT control statement in the Installation Default Option Table, the value will be applied to Smart Reorg jobs. For more information, see <a href="#">“How to code HPSCOPT macro statements” on page 618</a>.</p>	PI40739
<p>(Smart Reorg utility) Support for a new rule and CRSS enhancement: If you use the new IBM.LAST_REORG.10 rule and enable the Conditional Reorganization Support Service (CRSS), the Smart Reorg utility evaluates the number of days since the last reorganization and reorganizes the database only when the number of days exceeds the threshold defined by the rule. For more information, see <a href="#">“Example 14: Conditional reorganization based on the number of days since the last reorganization” on page 199</a>. This APAR also enhances the CRSS to support IMS Online Reorganization Facility.</p>	PI32990

## SC19-1137-04 (March 2015)

Description	Related APARs
<p>IMS 14 support: IMS Database Reorganization Expert supports IMS 14. To use IMS Database Reorganization Expert with IMS 14, the following APARs are also required for the related products:</p> <ul style="list-style-type: none"><li>• APAR PI27636 for IMS HP Unload 1.2</li><li>• APAR PI27637 for IMS HP Load 2.1</li><li>• APAR PI27638 for IMS Index Builder 3.1</li><li>• APAR PI27561 for IMS HP Image Copy 4.2</li><li>• APAR PI27640 for IMS HP Prefix Resolution 3.1</li><li>• APAR PI27563 for IMS HP Pointer Checker 3.1</li><li>• APAR PI27566 for IMS Library Integrity Utilities 2.2</li><li>• APAR PI26352 for Tools Base 1.5</li></ul>	PI27634
<p>Change in the return code for IMS Tools Knowledge Base failures: The return code that indicates an IMS Tools Knowledge Base Output repository processing failure is changed from 4 to 0. This change was implemented to unify the behavior of the products across IMS Database Solution Pack.</p> <p>If you want return code 4 to be returned for IMS Tools KB Output processing failures, specify the ERRC04 keyword for the ITKBSRVR control statement. For more information about this keyword, see the following topics:</p> <ul style="list-style-type: none"><li>• (Smart Reorg utility) <a href="#">“ITKBSRVR control statement” on page 144</a></li><li>• (IPR Unload utility) <a href="#">“ITKBSRVR control statement” on page 374</a></li><li>• (IPR Reload utility) <a href="#">“ITKBSRVR control statement” on page 521</a></li></ul>	PI17978 and PI32987
<p>(Pre-reorganization and Post-reorganization utilities) OSAM large format sequential data set support: The Pre-reorganization and Post-reorganization utilities now support databases that use OSAM large format sequential data sets. For more information, see the following topics:</p> <ul style="list-style-type: none"><li>• <a href="#">“Control statements for the (PREFIXRES) block” on page 311</a></li><li>• <a href="#">Chapter 18, “Post-reorganization utility JCL requirements,” on page 313</a></li></ul>	PI17557
<p>(IPR Reload utility) CHKEMPTYUL control statement support: You can use new control statement, CHKEMPTYUL, to check if the unloaded data set contains segment data. You can also use it to specify the return code that is set when no segment data is found in the unloaded data set. For more information, see <a href="#">“CHKEMPTYUL control statement” on page 511</a>.</p>	PI14951
<p>(IPR Unload utility) Type-B user exit routine enhancement: The IPR Unload utility now accepts return codes 100 - 999 from the Type-B user exit routine. For more information, see the following topics:</p> <ul style="list-style-type: none"><li>• <a href="#">“Type-B user exit” on page 456</a></li><li>• <a href="#">“IPR Unload utility return codes” on page 662</a></li></ul>	PI13315

Description	Related APARs
<p>(Smart Reorg utility) Enhancements related to HALDB processing</p> <ul style="list-style-type: none"> <li>• The Smart Reorg utility now supports XTLOT (extended task input/output table) for allocation of HALDB data sets. For more information, see <a href="#">“DYNALLOC control statement”</a> on page 136.</li> <li>• When REORG NUMBER VERIFICATION=YES is set in the RECON data sets, the Smart Reorg utility requests DBRC to update the HALDB reorganization number in the RECON data sets.</li> </ul>	PI11626
<p>(Smart Reorg utility) New data element for DB Sensor: DB Sensor collects new data element, DB_AVG_LEN_SYNONYM_CHAIN. This data element is for reporting the average length of all synonym chains in the data set that have a length greater than or equal to 2. For more information, see <a href="#">“SENSOR_HOME control statement”</a> on page 166.</p>	PI08979

### SC19-1137-03

Description	Related APARs
<p>(Smart Reorg utility) Partitioned secondary indexes build for HALDBs: The Smart Reorg utility can rebuild partitioned secondary indexes (PSINDEXes) while reorganizing HALDBs. This function can be enabled by the PSINDEXBLD control statement. For more information, see <a href="#">“PSINDEXBLD control statement”</a> on page 153.</p>	PM94787
<p>(Smart Reorg utility) Conditional reorganization without automatic post-reorganization processing: The Smart Reorg utility is enhanced to support conditional reorganization of databases even when automatic post-reorganization processing is not requested.</p>	PM99143
<p>Support of IMS database group-managed reorganization: The Smart Reorg utility, the Pre-reorganization utility, the Post-reorganization utility, and the IPR Scan utility can send system notification to IMS Tools Base Autonomics Director to indicate the completion of the job. Autonomic Director will use this notification as a trigger to start analyzing and generating recommendations for the database. This function can be enabled by the new ADXCFGRP and the ADDBGRP control statements. For more information, see <a href="#">“ADXCFGRP control statement”</a> on page 127 and <a href="#">“ADDBGRP control statement”</a> on page 127. For the IPR Scan utility, see <a href="#">“ADXCFGRP control statement”</a> on page 593 and <a href="#">“ADDBGRP control statement”</a> on page 593.</p>	PM86931
<p>(IPR Reload utility) Padding character support for segment length: You can specify the padding character to fill out the segments to adjust to the length that is defined in the DBD definition. For more information, see <a href="#">“PAD control statement”</a> on page 523.</p>	PM82938
<p>(IPR Reload utility) Reporting of twin chained segments: You can use the new TWINSTAT control statement to print statistics about the twin chained segments in the Segment Statistics report. For more information, see <a href="#">“TWINSTAT control statement”</a> on page 530.</p>	PM79676

Description	Related APARs
<p>IMS 13 support: IMS Database Reorganization Expert supports IMS 13. To use IMS Database Reorganization Expert with IMS 13, the following APARs are also required for the related products:</p> <ul style="list-style-type: none"> <li>• APAR PM75257 for IMS HP Unload 1.2</li> <li>• APAR PM75254 for IMS HP Load 2.1</li> <li>• APAR PM75258 for IMS Index Builder 3.1</li> <li>• APAR PM75253 for IMS HP Image Copy 4.2</li> <li>• APAR PM75256 for IMS HP Prefix Resolution 3.1</li> <li>• APAR PM75255 for IMS HP Pointer Checker 3.1</li> <li>• APAR PM75259 for IMS Library Integrity Utilities 2.1</li> <li>• APAR PM75247 for Tools Base 1.3</li> </ul>	PM75249
<p>(Pre-reorganization and Post-reorganization utilities) New reports for the Pre-reorganization utility: The Pre-reorganization utility generates the following two new reports:</p> <ul style="list-style-type: none"> <li>• List of Databases Need to be Processed report</li> <li>• Work Data Set Information report</li> </ul> <p>For more information about these reports, see <a href="#">“HPSOUT data set (Pre-reorganization utility)”</a> on page 336.</p>	PM72877
<p>(IPR Reload utility) Support reassigning of indirect list keys: If duplicated indirect list keys (ILKs) exist, you can use the new REPAIRILK control statement to reassign ILKs. For more information, see <a href="#">“REPAIRILK control statement”</a> on page 526.</p>	PM68883
<p>(Pre-reorganization and Post-reorganization utilities) Pre-reorganization utility and the Post-reorganization utility: IMS Database Reorganization Expert provides these two new utilities for reorganization of databases that have external logical relationships. The Pre-reorganization utility is used before the Smart Reorg job step to do pre-reorganization processing. The Post-reorganization utility is used after the Smart Reorg job step to do post-reorganization processing. For more information, see <a href="#">Chapter 14, “Pre-reorganization utility and Post-reorganization utility,”</a> on page 287.</p>	PM68661
<p>(IPR Reload utility) Generate work files for rebuilding partitioned secondary indexes: Supports generating work files (WFP work data sets) that can be used as input to IMS Index Builder to rebuild partitioned secondary indexes (PSINDEXes) in a separate job step. For more information, see <a href="#">HPSRPnnn DD statement in Chapter 34, “IPR Reload JCL requirements,”</a> on page 491 and <a href="#">WFPxxxx control statements in “Overview of the IPR Reload control statements”</a> on page 502.</p>	PM62216
<p>(IPR Reload utility) Support data class and storage class specifications for HPSRILEA and HPSRILEB data sets: You can specify the data class (DATACLAS) and the storage class (STORCLAS) for the HPSRILEA and HPSRILEB data sets. These data sets are used in rebuilding ILDSs and are used as substitute for the SORTIN data sets of DFSORT. For more information, see <a href="#">“ILEDATAC control statement”</a> on page 519 and <a href="#">“ILESTORC control statement”</a> on page 519.</p>	PM60646
<p>(IPR Reload utility) SORT statement: The SORT control statement, which specifies to run the physical sequential sort processing before reload, can now be specified together with the USERHDR or USERHDRX statement. For more information, see <a href="#">“SORT control statement”</a> on page 528.</p>	PM57126 (APAR for IMS High Performance Load)

Description	Related APARs
(IPR Unload utility) BLDLPCK statement enabled for installation default option: You can set the default value for the BLDLPCK control statement in the Installation Default Option Table and that value will be applied to IPR Unload jobs. For more information, see <a href="#">“How to code HPSCOPT macro statements”</a> on page 618.	PM55891
(IPR Reload utility) SORT statement enabled for installation default option: You can set the default value for the SORT control statement in the Installation Default Option Table and that value will be applied to IPR Reload jobs. For more information, see <a href="#">“How to code HPSCOPT macro statements”</a> on page 618.	PM52306
(IPR Unload utility) Migration unload and fallback unload support: You can use the IPR Unload utility when you migrate a non-partitioned database to a partitioned database, or a partitioned database to a non-partitioned database. The utility unloads the database in the required format for migration. For more information, see <a href="#">“MIGRATE control statement”</a> on page 375 and <a href="#">“FALLBACK control statement”</a> on page 372.	PM51943
(IPR Reload utility) DDEFPS DD statement for deleting and defining database data sets: You can specify the DDEFPS DD statement so that the database data sets are automatically deleted or defined during the IPR Reload job step. For more information, see DDEFPS DD statement in <a href="#">Chapter 34, “IPR Reload JCL requirements,”</a> on page 491.	PM46446

## SC19-1137-02

Description	Related APARs
(Smart Reorg utility) The Smart Reorg Driver supports the following new functions: <ul style="list-style-type: none"> <li>• The statistics about the primary indexes of HIDAM and PHIDAM databases are displayed in the Diagnosis report.</li> <li>• When the TOSIXCFGROUP control statement is specified, the latest VSAM statistics is collected from the database that is online.</li> </ul>	PM50158
(Smart Reorg utility) Reorganization Diagnosis mode support: The Smart Reorg Driver supports Reorganization Diagnosis mode to reorganize the database regardless of the results from policy evaluation, and generate a Diagnosis report.	PM38767
(Smart Reorg utility) Change in the default value of the ILDSBLD statement: The ILDSBLD=YES specification is obsolete. The default value for the ILDSBLD control statement is changed from ILDSBLD=YES to ILDSBLD=YES,DSPR.	PM33765
(IPR Reload utility) Change in the default value of the ILDSBLD statement: The ILDSBLD=YES specification is obsolete. The default value for the ILDSBLD control statement is changed from ILDSBLD=C to ILDSBLD=YES,DSPR.	PM33765
(Smart Reorg utility) LASTAUTHFLAG statement for restoring authorization flags: The Smart Reorg Driver supports the LASTAUTHFLAG control statement to restore the authorization flags in RECON to the original state.	PM31076

Description	Related APARs
(Smart Reorg utility) IMS 12 support: The Smart Reorg Driver supports IMS 12. To use the Smart Reorg Driver with IMS 12, the following APARs are also required for the related products.	PM22116
<ul style="list-style-type: none"> <li>• APAR PM22119 for IMS HP Unload 1.2</li> <li>• APAR PM22118 for IMS HP Load 2.1</li> <li>• APAR PM22120 for IMS Index Builder 3.1</li> <li>• APAR PM21942 for IMS HP Image Copy 4.2</li> <li>• APAR PM22121 for IMS HP Prefix Resolution 3.1</li> <li>• APAR PM21945 for IMS HP Pointer Checker 3.1</li> <li>• APAR PM21961 for IMS Library Integrity Utilities 2.1</li> <li>• APAR PM21167 for Tools Base 1.1</li> </ul>	

## SC19-1137-01

Description	Related APARs
(Smart Reorg utility) IMSCMDOPT statement support: The Smart Reorg Driver supports the IMSCMDOPT control statement to allow you change the options of the IMS commands that are issued by IMS Tools Online System Interface.	PM14690
(Smart Reorg utility) Generate DSPURX00 control statements: The Smart Reorg Driver generates DSPURX00 control statements that can be used for manual post processing.	PM12505
(IPR Unload utility) SKIPAUTH statement support: The IPR Unload utility supports the SKIPAUTH control statement to bypass IMS DBRC database authorization.	PM12287
(Smart Reorg utility) New parameter for the PIPEWAIT statement: The Smart Reorg Driver supports a third parameter for the PIPEWAIT control statement. You can specify different time periods for opening and reading/writing wait states.	PM11142
(IPR Reload utility) Generation of GDG base: The IPR Reload utility creates a GDG base when the base does not exist and when DFSURWF1 is defined as a generation data set.	PM09527

## IMS Database Reorganization Expert terminology

IMS Database Reorganization Expert includes several unique terms that you need to understand before you begin to use IMS Database Reorganization Expert.

### Unique terms used in this information

#### Conditional reorganization job

Refers to a Smart Reorg utility job that is run with the conditional reorganization function.

#### Exception or database exception

Refers to a database exception that is detected while a database is being evaluated. Exception conditions are based on threshold values that are defined in a reorganization policy.

#### Logical group

Refers to a group of databases that have logical relationships between the databases and their related index databases.

#### Name swapping or name swap

Refers to the name swapping process, which swaps the names of a shadow database and an original database, in a Smart Reorg utility job.

**Parallel reorganization**

Refers to the reorganization method that is used in the Smart Reorg utility. Multiple tasks, such as unload, reload, and index building tasks, are processed concurrently.

**Policy or reorganization policy**

Refers to a set of criteria that is used in the Smart Reorg utility job for evaluating database status.

**Rule**

Refers to a criteria for evaluating the status of a database. Rules are contained in one or more reorganization policies.

**Stand-alone utilities**

Refers to the IPR Unload utility, the IPR Reload utility, and the IPR DB Scan utility that are run individually.

**Short names and acronyms used in this information**

The various versions of IMS are referred to simply as IMS, except where distinctions among them need to be made.

In this information, the following abbreviations are used for product names.

<b>Acronym</b>	<b>Product or component name</b>
Autonomics Director	IBM IMS Tools Base for z/OS 1.7 or later (5655-V93), Autonomics Director
FF Stand-alone DB Sensor	The DB Sensor component in the following program products: <ul style="list-style-type: none"> <li>• IBM IMS Database Solution Pack for z/OS 2.2 (5655-DSP) or later</li> <li>• IBM IMS Database Utility Solution for z/OS 2.1 (5698-DUL) or later</li> </ul> The term FF Stand-alone DB Sensor refers to the DB Sensor component that runs as a stand-alone job.
IMS Database Solution Pack	IBM IMS Database Solution Pack for z/OS 2.2 (5655-DSP) or later
IMS Database Reorganization Expert or IMS DB Reorg Expert	IBM IMS Database Reorganization Expert for z/OS 4.1 (this product)
IMS Database Utility Solution	IBM IMS Database Utility Solution for z/OS 2.1 (5698-DUL) or later
IMS HALDB Toolkit	The generic name for the following program products: <ul style="list-style-type: none"> <li>• IBM IMS Database Solution Pack for z/OS, 2.2 (5655-DSP) or later, IMS High Availability Large Database Toolkit</li> <li>• IBM IMS Database Utility Solution for z/OS, 2.1 (5698-DUL) or later, IMS High Availability Large Database Toolkit</li> </ul>
IMS HP Image Copy	IBM IMS High Performance Image Copy for z/OS 4.2 (5655-N45)
IMS HP Load	IBM IMS High Performance Load for z/OS 2.1 (5655-M26)
IMS HP Pointer Checker	IBM IMS High Performance Pointer Checker for z/OS 3.1 (5655-U09)
IMS HP Prefix Resolution	IBM IMS High Performance Prefix Resolution for z/OS 3.1 (5655-M27)
IMS HP Unload	IBM IMS High Performance Unload for z/OS 1.2 (5655-E06)
IMS Index Builder	IBM IMS Index Builder for z/OS 3.1 (5655-R01)
IMS Library Integrity Utilities, IMS LIU, or LMU	IBM IMS Library Integrity Utilities for z/OS 2.2 (5655-U08)
IMS Online Reorganization Facility	IBM IMS Database Solution Pack for z/OS 2.2 (5655-DSP) or later, IMS Online Reorganization Facility



Acronym	Product or component name
IMS Parallel Reorganization or IMS Parallel Reorganization	IBM IMS Parallel Reorganization for z/OS 3.1 and 3.2 (5655-M28)
IMS Tools Base	IBM IMS Tools Base for z/OS 1.7 or later (5655-V93)
IMS Tools Knowledge Base or IMS Tools KB	IBM IMS Tools Base for z/OS 1.7 or later (5655-V93), IMS Tools Knowledge Base
IMS Tools Online System Interface	IBM IMS Tools Base for z/OS 1.7 or later (5655-V93), IMS Tools Online System Interface
Policy Services	IBM IMS Tools Base for z/OS 1.7 or later (5655-V93), Policy Services

## What is IMS Database Reorganization Expert?

IMS Database Reorganization Expert provides advanced functions that help IMS database administrators to perform database reorganization tasks.

Database reorganization typically involves complex analysis tasks. Generally, these time-consuming tasks require knowledge, expertise, and experience in space management of IMS databases. IMS Database Reorganization Expert facilitates the database reorganization tasks for IMS full-function databases by helping you automate and eliminate the complex tasks that pertain to database reorganization.

The main utility of IMS Database Reorganization Expert, *Smart Reorg utility*, offers two significant features:

- Conditional Reorganization Support Service (also referred to as CRSS)
- Parallel Reorganization Service

The Conditional Reorganization Support Service provides the database diagnosis function and the database status reporting function. It helps you by:

- Evaluating an IMS full-function database and determining the need for reorganization
- Requesting the reorganization process only when a database needs to be reorganized (based on the results of database evaluation)
- Reevaluating the reorganized database to check the effect of the reorganization
- Providing a comprehensive summary report on the database status and, when the database is reorganized, the change in the status

The Parallel Reorganization Service provides a high-performance reorganization function. It helps you by:

- Running the unload and the reload functions concurrently in a single job step
- Running the optional functions that typically pertain to reorganization tasks, such as index building, image copying and hash pointer checking, and prefix resolution and update tasks, concurrently in the same job step

The Parallel Reorganization Service provides the reorganization function by internally running the individual high-performance IMS Tools products. This service controls the entire reorganization scenario by coordinating the runs of the following products:

- The unload function that is provided by the High Speed Sequential Retrieval (HSSR) Engine of IMS HP Unload
- The reload function that is provided by IMS HP Load
- The index building function that is provided by IMS Index Builder
- The image copy function that is provided by IMS HP Image Copy
- The HASH pointer checking function that is provided by IMS HP Pointer Checker
- The prefix resolution and update functions that are provided by IMS HP Prefix Resolution

With these two features, the Smart Reorg utility enables the *conditional reorganization* function. The conditional reorganization function automates the database diagnosis process and, only when the diagnosis process determines that the database needs reorganization, performs the reorganization, all in a single job step. In these topics, a Smart Reorg utility job that is run with the conditional reorganization function is referred to as *conditional reorganization job*.

By using the Smart Reorg utility, you can reduce the amount of work and expertise that are required for database reorganization tasks and realize higher productivity with less maintenance time and training costs.

The Smart Reorg utility supports HDAM and HIDAM databases that have external logical relationships. The following three utilities provide the supplementary functions to reorganize such databases:

- The Pre-reorganization utility detects to-be-processed databases in a logical group of databases.
- The IPR DB Scan utility generates DFSURWF1 data sets, which can be used to resolve logical relationships, for databases that are not reorganized.
- The Post-reorganization utility performs the prefix resolution and update tasks for the databases in the logical group.

The product also provides a simple JCL interface to both IMS HP Unload and IMS HP Load. The following reorganization utilities are available through this interface:

- The IPR Unload utility invokes IMS HP Unload through the interface and provides the database unload function and the application programming interface.
- The IPR Reload utility invokes IMS HP Load through the interface and provides the database reload function.
- The IPR DB Scan utility invokes IMS HP Unload and provides the DB Scan function.

In these topics, these utilities are sometimes called stand-alone utilities to differentiate them from the Smart Reorg utility that invokes and runs IMS HP Unload and IMS HP Load in parallel.

#### **Notes:**

- The JCL interface for these reorganization utilities is compatible with IBM IMS Parallel Reorganization for z/OS (also referred to as IPR). As in IMS Parallel Reorganization, IMS Database Reorganization Expert provides just the JCL interface to IMS HP Unload and IMS HP Load. The actual unload or DB scan processing and the reload processing are performed by respective tool products.
- These stand-alone utilities can be used as functional replacements:
  - The IPR Unload utility is equivalent to the IMS HD Reorganization Unload utility (DFSURGU0)
  - The IPR Reload utility is equivalent to the IMS HD Reorganization Reload utility (DFSURGLO)
  - The IPR DB Scan utility is equivalent to the IMS Database Scan utility (DFSURGS0)

## **IMS Database Reorganization Expert features and benefits**

---

IMS Database Reorganization Expert provides features and benefits that help database administrators to reorganize IMS full-function databases.

Subsections:

- [“Smart Reorg utility” on page 18](#)
- [“Pre-reorganization utility and Post-reorganization utility” on page 20](#)
- [“IPR Unload utility” on page 20](#)
- [“IPR Reload utility” on page 20](#)
- [“IPR DB Scan utility” on page 21](#)

### **Smart Reorg utility**

#### **Features**

The Conditional Reorganization Support Service (CRSS) diagnoses a database and determines if the database needs to be reorganized. It provides the following features:

- Conditional reorganization
  - Supports the reorganization policies in which user-defined criteria for detecting database exceptions are defined.
  - Collects statistics data of the target database and, by using a reorganization policy, evaluates the statistics data to determine if the database needs to be reorganized. When a database needs to be reorganized, the CRSS requests the Smart Reorg Driver to run the reorganization process in the same job step.
- Exception reporting and process tracking
  - Detects database exceptions and notifies the exceptional state of the database to specific TSO users and z/OS operators.
  - Generates a diagnosis report that summarizes the database statistics, whether the criteria for reorganization were met, and, when database is reorganized during the job, the statistics of the reorganized database.

The Parallel Reorganization Service provides the capability to run automated high-performance single-step reorganization. It provides the following features:

- Runs the unload, the reload, and the optional tasks, including the index building, the image copy and HASH pointer checking, and the prefix resolution and update (for internal logical relationships) tasks concurrently as subtasks in a single job step.
- Provides the advanced data transfer service, which is called IPRPIPE. This service passes unloaded records from the Unload task directly to the Reload task to reduce the number of I/Os.
- Supports the dynamic allocation of input database data sets, shadow database data sets, and the output secondary indexes.
- Provides full DBRC support, including DBRC authorization and notification processing.
- Automates IMS online command processing for taking databases offline so that they can be reorganized, and for restarting databases after reorganization for online use.
- Provides capability of taking image copy and performing pointer checking while the database is being reloaded from an unload data set without using shadow data sets.

### **Benefits**

The Conditional Reorganization Support Service provides the following benefits:

- Supports a central repository to manage all the essential information for database reorganization activities.
- Preserves the maintenance time window by providing the ability to reorganize a database only when it is needed.
- Informs you about the status of your databases by providing early notification of database exceptional conditions.
- Provides practical database reorganization criteria in the out-of-box policy templates, which you can use to reduce complex decision-making tasks.
- Provides a simple customization and maintenance approach for policies through an ISPF interface.
- Provides historical reports that are preserved in the centralized repository. You can use these reports for future analysis, problem-solving, and research on databases.

The Parallel Reorganization Service provides the following benefits:

- Simplifies the control of reorganization tasks.
- Shortens the elapsed time for end-to-end reorganization tasks with high-performance reorganization technology.
- Facilitates the reorganization tasks by simplifying JCL specification.

## Pre-reorganization utility and Post-reorganization utility

### Features

Automates pre-reorganization processing and post-reorganization processing for databases that have external logical relationships.

### Benefits

- Simplifies reorganization of databases that have external logical relationships.
- Reduces manual intervention required for pre-reorganization and post-reorganization processing.

## IPR Unload utility

### Features

- Retrieves segments with a high-performance method by using the HSSR Engine that is provided by IMS HP Unload. HSSR Engine provides the facility to retrieve segments much faster than DL/I.
- Generates statistics reports that can be used for tuning databases. Statistics reports on database record lengths and randomizing, which are valuable as database tuning aid, can be generated optionally.
- Supports the user exit facility to allow additional processing for retrieved segments. This user exit facility allows more control over unload process than the IMS HD Reorganization Unload utility. The IPR Unload utility supports two types of user exits.
- Supports various unload data set formats.
- Supports various database organizations.
- Dynamically allocates database data sets to be unloaded.
- Provides an application programming interface (API) that enables IMS batch DL/I application programs that read a database sequentially to use HSSR Engine. This API enables the application programs to benefit from the high-performance segment retrieval processing of HSSR Engine.
- Reorganizes a partition or a sequence of partitions of a HALDB.
- Enables the processing to continue after sequence errors. HSSR Engine optionally does sequence-key checks for twin chains. You can select how to process a sequence error from several methods.
- Reads a damaged database. HSSR Engine gives you greater control when you run the IPR Reload utility or the IPR DB Scan utility for a database that has an incorrect pointer.

### Benefits

- Reduces time and costs for unloading an IMS database through high-speed unloading engine.
- Simplifies JCL streams for database unload jobs and segment retrieval application jobs.
- Provides more flexibility in controlling database unload jobs through user exit routines.
- Offers several approaches for processing damaged databases.
- Simplifies and facilitates database diagnosis tasks by providing statistics reports.

## IPR Reload utility

### Features

- Enables you to load a database by using high-performance techniques. The utility performs high-performance reloading of IMS HD databases from an unload data set that was created by IMS HD Reorganization Unload utility or by a compatible utility.
- Generates statistics reports that can be used for tuning databases. The reports include statistics about data sets, segments, and segment pointers.
- Supports logical relationships and secondary indexes.
- Provides a user exit facility to allow additional processing of each segment. The user exit facility enables selections or modifications of segments from the unloaded data set.

- Supports the unloaded files with customized segment header. The utility can optionally reload the unloaded data set that has a customized segment header.
- Initializes empty HDAM, HIDAM, PHDAM, PHIDAM, HISAM, and SHISAM databases.

#### **Benefits**

- Reduces time and costs for reloading an IMS database through high-speed reloading engine.
- Simplifies JCL streams for database reload jobs.
- Provides more flexibility in controlling database reload jobs.
- Simplifies and facilitates database tuning and space analysis tasks by providing statistics reports.

### **IPR DB Scan utility**

#### **Features**

- Provides the database scan function that is compatible with the IMS Database Scan utility.
- Uses the high-performance engine (HSSR Engine) that is provided by IMS HP Unload.

#### **Benefits**

- Provides faster scanning than is provided by the standard IMS Database Scan utility.
- Simplifies JCL streams for database scan jobs.

## **IMS Database Reorganization Expert environment and process flow**

---

The IMS Database Reorganization Expert environment is composed of several IMS Tools products.

This topic introduces a typical environment for running a conditional reorganization job. A typical environment requires the following components:

- IBM IMS Database Reorganization Expert for z/OS (this product)
- IBM IMS High Performance Unload for z/OS
- IBM IMS High Performance Load for z/OS
- IBM IMS Tools Base for z/OS: IMS Tools Knowledge Base
- IBM IMS Tools Base for z/OS: Policy Services

The following diagram illustrates the environment and the process flow for using the Smart Reorg utility with the conditional reorganization function.

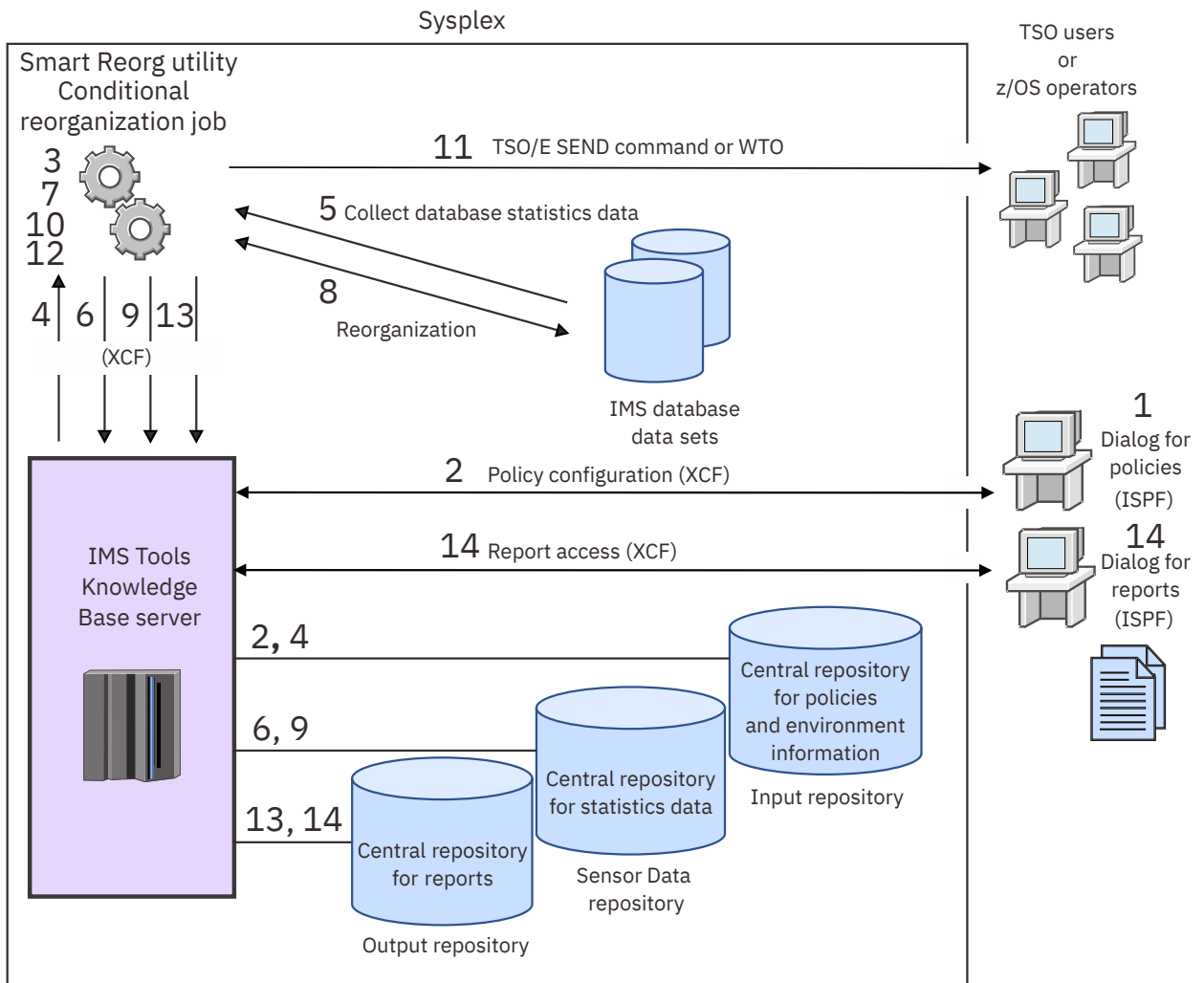

Figure 1. Environment and process flow of a conditional reorganization job

The following process flow steps match the numbers in the diagram:

1. The user defines a reorganization policy by using the Policy Services ISPF user interface.
2. Policy Services stores the policy and the exception detection rules used by the policy in the Input repository, which is managed by the IMS Tools KB server.
3. The user submits a conditional reorganization job.
4. Policy Services, which is used in the job, retrieves the designated reorganization policy from the Input repository.
5. The conditional reorganization job reads blocks of database data sets to collect statistics data.
6. Policy Services stores the collected statistics data in the Sensor Data repository, which is managed by the IMS Tools KB server.
7. The conditional reorganization job evaluates the collected statistics data by using the specified policy to detect exceptional state of the database and to determine the appropriate actions for those exceptions.
  - If the process determines that the database needs to be reorganized, the process continues with step “8” on page 22.
  - If the process determines that the database does not need to be reorganized, the process continues with step “11” on page 23.
8. The conditional reorganization job reorganizes the database data sets. In the reorganization reload process, the statistics data about the reorganized database is collected.

9. Policy Services stores the collected statistics data of the reorganized database in the Sensor Data repository.
10. Policy Services evaluates the statistics data of the reorganized database by using the same reorganization policy.
11. If one or more database exceptions were found, Policy Services notifies the TSO users or the z/OS operators that are designated by the policy.
12. The conditional reorganization job generates a diagnosis report for the database.
13. The conditional reorganization job stores the reports that were generated by the job, including the diagnosis report, in the Output repository, which is managed by the IMS Tools KB server.
14. The user searches for the diagnosis report by using the ISPF user interface, and checks the latest database status or the history of status changes.

### Related tasks

#### Configuring the IMS Database Reorganization Expert environment

IMS Database Reorganization Expert must be configured to meet the demands of your specific environment. Without configuration and setup, the product is not fully operational.

## IMS Database Reorganization Expert restrictions

---

Certain restrictions apply to using the utilities of IMS Database Reorganization Expert.

All utilities have the following restrictions:

- Utilities cannot run under IMS Utility Control Facility (UCF).
- Utilities do not support the checkpoint and restart capability.
- Utilities do not support any user-written Data Conversion exit routine (DFSDBUX1 routine).

**Note:** The IPR Unload utility and the IPR Reload utility support control statement DATXEXIT=YES to activate the Data Conversion exit routine (DFSDBUX1) provided by IMS/ESA® Year 2000 Exit Tool (5697-E04). No other DFSDBUX1 routine is supported. The Unload task or the Reload task of the Smart Reorg utility does not support control statement DATXEXIT=YES.

- Utilities do not support IMS catalog databases that are not registered to RECON data sets.

For other restrictions of each utility, see the topics of each utility.

### Related concepts

Smart Reorg restrictions and requirements

Some restrictions apply to using the Smart Reorg utility.

Restrictions for the Pre-reorganization utility and the Post-reorganization utility

Certain restrictions apply to using the Pre-reorganization utility and the Post-reorganization utility.

IPR Unload restrictions and considerations

The IPR Unload utility has certain restrictions.

IPR Reload restrictions

The IPR Reload utility has certain restrictions.

IPR DB Scan restrictions and considerations

The IPR DB Scan utility has certain restrictions.

## Functional changes

---

The following topics describe major functional changes that have been made to IMS Database Reorganization Expert.

These topics also describe major functional changes that were provided in IMS Parallel Reorganization 3.1 and 3.2. Any functional change that was made in IMS Parallel Reorganization 3.1 and 3.2 releases are incorporated into IMS Database Reorganization Expert unless otherwise stated.

## Changes in IMS Database Reorganization Expert 4.1

This topic describes major functional changes that were made to IMS Database Reorganization Expert 4.1.

### Smart Reorg utility

The *IPR Driver* of IMS Parallel Reorganization 3.2 has been enhanced significantly to support the Conditional Reorganization Support Service and the utility has been renamed to the *Smart Reorg utility*.

The Smart Reorg utility provides two major functions:

- Policy-based database diagnosis
- Parallel reorganization that can be conditionally performed based on the result of database diagnosis

The following functions have been added to the Smart Reorg utility in IMS Database Reorganization Expert 4.1:

#### **Create image copies even when the database or HALDB partitions are not reorganized**

Enhancement by APAR PH41443. The Smart Reorg utility can create image copies of all database data sets and HALDB partitions even when the CRSS determines that reorganization of the entire database or some partitions are not needed. For more information, see [“CRIC control statement” on page 130](#).

#### **Create an unload data set in conditional reorganization jobs**

Enhancement by APAR PH41443. The Smart Reorg utility can create an unload data set that contains data from the database or HALDB partitions. You can choose to create an unload data set only when the CRSS determines that reorganization is needed or every time the job is run (regardless of whether reorganization is needed). For more information, see [“CRUNLOAD control statement” on page 130](#).

#### **Encrypted IMS OSAM database support**

The Smart Reorg utility and the Conditional Reorganization Support Service (CRSS) were enhanced by APARs PH26055 and PH35209 to support encrypted IMS OSAM database data sets.

#### **Conditional unload support**

The Smart Reorg utility was enhanced by APAR PH12332 so that the Smart Reorg utility can unload the database without reorganizing it. For more information see [“Example 16: Conditionally reorganizing a database in separate job steps” on page 202](#).

#### **IMS management of ACBs support**

The Smart Reorg utility was enhanced by APAR PH04969 so that it can refer to database definitions in the IMS catalog instead of DBD libraries when the IMS management of ACBs is enabled. For more information, see the following topics:

- [“Considerations for the IMS management of ACBs” on page 115](#)
- [“Example 15: Reorganizing a database when the IMS management of ACBs is enabled” on page 201](#)

#### **zIIP support**

The Smart Reorg utility was enhanced by APAR PI88158 to support IBM z Integrated Information Processor (zIIP) to offload eligible workloads to zIIP processors. For more information, see [“ZIIPMODE control statement” on page 162](#).

#### **Building HALDB PSINDEXes in update mode**

The Smart Reorg utility supports building PSINDEXes when it reorganizes all the partitions of a HALDB. By APAR PI81313, the Smart Reorg utility has been enhanced to support building PSINDEXes even when some partitions of the HALDB are reorganized. For more information, see [“PSINDEXBLD control statement” on page 153](#).

#### **Performance improvement with the CABBASE statement**

The IPR Unload utility was enhanced by APAR PI77308 to support a new control statement, CABBASE. This statement specifies the basic size of I/O buffers that the CAB buffer handler allocates. This statement can be applied to the Unload task of Smart Reorg utility jobs to improve the performance of Smart Reorg utility jobs. For more information, see [“CABBASE control statement” on page 396](#).



### **HALDB multiple partition support for CRSS**

The Smart Reorg utility was enhanced by APAR PI64268 so that the CRSS can process multiple partitions of a HALDB. If you specify CONDREORG=YES, the CRSS diagnoses all the partitions and the Smart Reorg utility reorganizes only the partitions that require reorganization. Also you can use the PARTITION control statement to specify non-sequential partitions. For more information, see the following topics:

- [“CONDREORG control statement” on page 128](#)
- [“PARTITION control statement” on page 150](#)

### **Support for Reorganization Diagnosis mode**

The Smart Reorg Driver was enhanced by APAR PM38767 to support Reorganization Diagnosis mode. When you run the Smart Reorg utility in this mode, the Smart Reorg Driver reorganizes the database regardless of the results from policy evaluation, and generates a Diagnosis report.

### **Enabling GLOBAL option for IMS commands that are issued by IMS TOSI**

The Smart Reorg Driver was enhanced by APAR PM14690 to support the IMSCMDOPT control statement. This control statement allows you to change the options of the IMS commands that are issued by IMS Tools Online System Interface (IMS TOSI).

By using the new control statement, the Smart Reorg Driver can issue /DBD, /DBR, and /STA commands with the GLOBAL option through IMS TOSI. See [“IMSCMDOPT control statement” on page 142](#) for more information about the IMSCMDOPT control statement.

### **Generation of DSPURX00 control statements for manual post processing**

The Smart Reorg Driver was enhanced by APAR PM12505 to support the generation of the DSPURX00 control statements for manual post processing. The HPSGDBRC data set can be used as SYSIN for the succeeding DSPURX00 job step. For more information, see the following topics:

- The description of the HPSGDBRC DD in [“DD names common to all processing options” on page 95](#)
- [“Performing manual name swapping” on page 212](#)

### **Better handling of the PIPEWAIT option**

The Smart Reorg Driver was enhanced by APAR PM11142 to support the third parameter (OPEN or RDWR) of the PIPEWAIT control statement. By this enhancement, the PIPEWAIT control statement can specify different time periods for opening and reading/writing wait states. See [“PIPEWAIT control statement” on page 152](#).

For details about the Smart Reorg utility, see [Chapter 4, “Smart Reorg utility,” on page 55](#).

## **Pre-reorganization utility and Post-reorganization utility**

New utilities, Pre-reorganization utility and Post-reorganization utility, have been added by APAR PM68661. These utilities are for reorganizing databases that have external logical relationships. The Pre-reorganization utility is used before the Smart Reorg job step to do pre-reorganization processing. The Post-reorganization utility is used after the Smart Reorg job step to do post-reorganization processing. For more information, see [Chapter 14, “Pre-reorganization utility and Post-reorganization utility,” on page 287](#).

## **IPR Unload utility**

The following function has been added to the IPR Unload utility in IMS Database Reorganization Expert 4.1:

### **Encrypted IMS OSAM database support**

The IPR Unload utility was enhanced by APAR PH22529 to support encrypted IMS OSAM database data sets.

### **zIIP support**

The IPR Unload utility was enhanced by APAR PI88158 to support IBM z Integrated Information Processor (zIIP) to offload eligible workloads to zIIP processors. For more information, see [“ZIIPMODE control statement” on page 404](#).

### **IMS management of ACBs support**

The IPR Unload utility was enhanced by APAR PI83671 so that it can refer to database definitions in the IMS catalog instead of DBD libraries when the IMS management of ACBs is enabled. For more information, see the following topics:

- [“Example 5: Unloading a database in an IMS-managed ACBs environment” on page 407](#)
- [“Example 6: Unloading a database with the IMS Catalog Definition exit routine” on page 407](#)
- (IPR Unload API) [“Example 2: Running an HSSR application program in an IMS-managed ACBs environment” on page 477](#)
- (IPR Unload API) [“Example 3: Running an HSSR application program with the IMS Catalog Definition exit routine” on page 478](#)

### **Performance improvement with the CABBASE statement**

The IPR Unload utility was enhanced by APAR PI77308 to support a new control statement, CABBASE. This statement specifies the basic size of I/O buffers that the CAB buffer handler allocates. For more information, see [“CABBASE control statement” on page 396](#).

### **Bypassing IMS DBRC database authorization process**

The IPR Unload utility was enhanced by APAR PM12287 to support the SKIPAUTH control statement. By using this control statement, you can bypass IMS DBRC database authorization to avoid DBRC authorization failure. See [“SKIPAUTH control statement” on page 386](#).

## **IPR Reload utility**

The following function has been added to the IPR Reload utility in IMS Database Reorganization Expert 4.1:

### **Encrypted IMS OSAM database support**

The IPR Reload utility was enhanced by APAR PH22458 to support encrypted IMS OSAM database data sets.

### **zIIP support**

The IPR Reload utility was enhanced by APAR PI88156 to support IBM z Integrated Information Processor (zIIP) to offload eligible workloads to zIIP processors. For more information, see [“ZIIPMODE control statement” on page 536](#).

### **IMS management of ACBs support**

The IPR Reload utility was enhanced by APAR PI79464 so that it can refer to database definitions in the IMS catalog instead of DBD libraries when the IMS management of ACBs is enabled. For more information, see the following topics:

- [“Example 3: Reloading a database in an IMS-managed ACBs environment” on page 538](#)
- [“Example 4: Reloading a database with the IMS Catalog Definition exit routine” on page 539](#)

### **Generation of GDG base**

The IPR Reload utility was enhanced by APAR PM09527 to support generation of GDG base when both of the following conditions are met:

- The base does not exist.
- DFSURWF1 is defined as a generation data set.

See [“WF1DSN control statement” on page 533](#) for more information about defining DFSURWF1 as a generation data set, and [“GDGBASE control statement” on page 517](#) for more information about generating GDG base.

## **IPR DB Scan utility**

No major change has been made in the IPR DB Scan utility.

## Changes in IMS Parallel Reorganization 3.2

This topic describes major functional changes that were made to IMS Parallel Reorganization 3.2.

### The IPR Driver (Smart Reorg utility)

The following functions were added to the IPR Driver in IMS Parallel Reorganization 3.2:

#### Automated /START DB after reorganization

The IPR Driver was enhanced to automatically take the database offline before the database reorganization and to automatically bring back the database online after the reorganization. This feature is enabled by the IMS Tools Online System Interface, which issues the IMS commands, such as /START DB, /DBD, and /DBR commands. For more information about activating IMS Tools Online System Interface, see [“IMSCMD control statement” on page 140](#) and [“STARTDB control statement” on page 158](#). To check the results of the commands that were issued to the IMS subsystems, see [“IMS Command Processing report” on page 270](#).

#### Using an unload data set as input

The IPR Driver was enhanced to support an unload data set as the input for database reorganization. This option allows you to use the IPR Driver as a reload utility, to which one or more optional functions such as IMS Index Builder, IMS HP Prefix Resolution, and IMS HP Image Copy with IMS HP Pointer Checker can be added. In this type of processing, the shadow data sets are not used. For more information about enabling this option, see [“REORGINPUT control statement” on page 155](#).

#### Setting the installation default option for a Reload task

The IPR Driver was enhanced to support installation default option for the OADSPR control statement for the Reload task. The default value of the OADSPR control statement that is specified in the Installation Default Option Table (HPSCOPTI) for the IPR Reload utility can be used in the Reload task within an IPR Driver job. For more information, see [Chapter 45, “Setting installation default options,” on page 617](#).

#### Accepting non APF-authorized libraries

The IPR Driver was enhanced to accept non APF-authorized libraries to be specified on the STEPLIB DD statement.

Some restrictions apply when using non APF-authorized libraries. For more information, see STEPLIB DD in [“DD names common to all processing options” on page 95](#).

#### Requesting database authorization for secondary indexes

The IPR Driver was enhanced to request DBRC database authorization for secondary indexes, in addition to the primary database and primary index. This request is made at the beginning of the reorganization processing for non-HALDBs. If IMS Library Integrity Utilities Integrity Checker is active, the DMBs for the secondary indexes are also verified.

#### DBRC notification processing in case of ILDSBLD=NO

The IPR Driver was enhanced to perform the DBRC notification after name swapping as part of the post-reorganization processing even when ILDSBLD=NO is specified for HALDB. After the IPR Driver job, you must run the IMS HALDB Index/ILDS Rebuild Utility (DFSPRECO) to rebuild ILDSs, but you do not need to manually perform the DBRC notification.

#### IMS 10 support

The IPR Driver was enhanced by APAR PK33131 to support IMS 10. The following new functions that were introduced in IMS 10 are supported by this APAR:

##### Parallel RECON access

Parallel RECON access is supported. For more information about using this option, see [“Setting up the DBRC SCI registration exit routine” on page 48](#).

##### DBRC timestamp precision

The IPR Driver issues the DBRC NOTIFY commands by using the timestamp with microsecond precision. This is effective when IMS RECON is defined as MINVERS('10.1').

The required APARs for each of the related products are:

- APAR PK33129 for IMS HP Load 2.1

- APAR PK29311 for IMS Index Builder 2.3
- APAR PK33116 for IMS HP Prefix Resolution 3.1

No APAR is needed for the following products:

- IMS HP Unload 1.2
- IMS HP Image Copy 4.2
- IMS HP Pointer Checker 3.1
- IMS Library Integrity Utilities 2.1

### **Extended capability of NEWDBD function**

The IPR Driver was enhanced by APARs PK33846 and PK43275 to support the following options when NEWDBD=ddname is specified to change database definition parameters within an IPR Driver job:

- IC=YES specified together with NEWDBD=ddname.
- The change for the randomizing parameters of HDAM database

**Note:** SORT=COND must be specified for the Reload task to activate the physical sequential sort before the reload process.

- Adding or deleting secondary index

For more information, see [“NEWDBD control statement” on page 149](#).

### **Non-HALDB that has external Logical relationships**

The IPR Driver was changed by APAR PK43275 to provide the following enhancements for the processing of non-HALDB that has external logical relationships:

- NAMESWAP=YES can be specified to swap data set names automatically. Users have to run IMS Prefix Resolution and Update utilities after the IPR Driver job steps. See [“External logical relationships” on page 214](#).
- If the logical child database contains no direct logical pointers, IC=YES is supported to take image copies. For more information, see [“Logical relationships that do not require Prefix Resolution and Update” on page 110](#).

### **Support for IMS Tools KB**

The IPR Driver was enhanced by APAR PK45143 to support IMS Tools KB to store and manage reports in a central repository. For information about configuring the IMS Tools KB environment, see [“Task 2: Completing configuration for IMS Tools Knowledge Base” on page 44](#). Some restrictions apply to using IMS Tools KB. For more information, see [“ITKBLOAD control statement” on page 144](#).

### **Reducing data space usage when building ILDS**

The IPR Driver was enhanced by APAR PK57505 to provide an option that reduces required data space when building ILDSs. For more information, see [“ILDSBLD control statement” on page 139](#).

### **SPACEALLOC function enhancements**

The IPR Driver was enhanced by APAR PK58598 to support allocation of DASD space for shadow OSAM data sets. The IPR Driver can process multi-volume data sets and large format data sets (DSNTYPE=LARGE). For more information, see [“SPACEALLOC control statement” on page 156](#).

### **Support for IMS Library Integrity Utilities 2.1**

The IPR Driver was enhanced by APAR PK69458 to support IMS Library Integrity Utilities 2.1. If the NEWDBD function is used and LIU Integrity Checker is activated, the RDE will be updated for the new DBD. For more information, see the *IMS Library Integrity Utilities User's Guide*.

### **IMS 11 support**

The IPR Driver was enhanced by APAR PK74303 to support IMS 11.1.

To use the IPR Driver with IMS 11.1, the following APARs are also required for the related products:

- APAR PK74302 for IMS HP Unload 1.2
- APAR PK74299 for IMS HP Load 2.1
- APAR PK73802 for IMS Index Builder 3.1

- APAR PK74296 for IMS HP Image Copy 4.1
- APAR PK74301 for IMS HP Prefix Resolution 3.1
- APAR PK74300 for IMS HP Pointer Checker 3.1
- APAR PK74275 for IMS Library Integrity Utilities 2.1

## The IPR Unload utility

The following functions were added to the IPR Unload utility in IMS Parallel Reorganization 3.2:

### JCL for IMS HD Reorganization Unload support

The IPR Unload utility was enhanced by APAR PK59511 to run by using JCL that is written for IMS HD Reorganization Unload (DFSURGU0). For more information, see [“Using JCL for IMS HD Reorganization Unload”](#) on page 364.

### IMS 10.1 support

The IPR Unload utility was enhanced by APAR PK33131 to support IMS 10.1. The following new functions that were introduced in IMS 10.1 are supported by this APAR.

#### Parallel RECON access

Parallel RECON access is supported. For more information about using this option, see [“Setting up the DBRC SCI registration exit routine”](#) on page 48.

#### Large sequential data set support enhancement

The IPR Unload utility supports the large format data set for unload data sets (the SYSUT2, the SYSUT3, and the SYSUT4 DD statements) and OSAM database data sets. This feature is supported in z/OS 1.7 or later.

### Support for IMS Tools KB

The IPR Unload utility was enhanced by APAR PK57504 to support IMS Tools KB to store and manage reports in a central repository. For information about configuring the IMS Tools KB environment, see [“Task 2: Completing configuration for IMS Tools Knowledge Base”](#) on page 44. Some restrictions apply to using IMS Tools KB. For more information, see [“ITKBLOAD control statement”](#) on page 373.

### IMS 11.1 support

The IPR Unload utility was enhanced by APAR PK74303 to support IMS 11.1.

To use the IPR Unload utility with IMS 11.1, you must apply APAR PK74302 to IMS HP Unload 1.2.

### Collecting information about largest or fragmented database records

The IPR Unload utility was changed to collect information about largest or fragmented database records and to produce an output for each database record. Each record in the output data set contains the length of a database record and the number of database I/Os that is required to read the database record. For more information, see [“LOUT control statement”](#) on page 400.

To use this function, you must apply APAR PK86493 to IMS HP Unload 1.2.

## The IPR Reload utility

The following functions were added to the IPR Reload utility in IMS Parallel Reorganization 3.2:

### Accepting non APF-authorized libraries

The IPR Reload utility was enhanced to accept non APF-authorized libraries to be specified on the STEPLIB DD statement.

Some restrictions apply when using non APF-authorized libraries. For more information, see STEPLIB DD in [“DD names common to all processing options”](#) on page 95.

### Checking database update between unload and reload processes

The IPR Reload utility was enhanced to check against DBRC to see if an update of the database has been done between unload and reload processes. For more information, see [“CHKUPDT control statement”](#) on page 512.

To use this function, APAR PK12257 is required for IMS HP Load 2.1.

### **Physical sequential sort before reloading**

The IPR Reload utility was enhanced to run the physical sequential sort processing before reloading a database. With this function, you can reload a database without PSSR even if the HDAM or the PHDAM database is not in physical sequence. This function is activated by the SORT=YES optional control statement.

To use this function, APARs PK07435 and PK09141 are required for IMS HP Load 2.1.

The IPR Reload utility was further changed to support conditional sorting. With this function, the physical sequential sorting is done conditionally based on the content of the input unloaded data set. This function is activated by the SORT=COND optional control statement.

To use this function, APAR PK21494 is required for IMS HP Load 2.1.

For more information about these functions and requirements on the input unload data set, see [“SORT control statement”](#) on page 528.

### **Reducing data space usage when reloading (P)HDAM overflow area**

The IPR Reload utility was enhanced to provide an option that reduces the data space usage when reloading the HDAM or the PHDAM overflow area. For more information, see [“OADSPR control statement”](#) on page 523.

To use this control statement, APAR PK16004 and PK18989 are required for IMS HP Load 2.1.

### **IMS 10.1 support**

The IPR Reload utility was enhanced by APAR PK33131 to support IMS 10.1. The following new functions that were introduced in IMS 10.1 are supported by this APAR.

#### **Parallel RECON access**

Parallel RECON access is supported. For more information about using this option, see [“Setting up the DBRC SCI registration exit routine”](#) on page 48.

#### **DBRC timestamp precision**

The IPR Reload utility adds the information about the reorganization by using the timestamp with microsecond precision. This function is effective when IMS RECON is defined as MINVERS('10.1').

#### **Large sequential data set support enhancement**

The IPR Reload utility supports the large format data set for unload data sets, OSAM database data sets, and OVERFLOW data sets. This feature is supported in z/OS 1.7 or later.

To use the IPR Reload utility with IMS 10, APARs PK33129 and PK42361 are required for IMS HP Load 2.1.

### **Initialization of empty HALDB partitions**

The IPR Reload utility was enhanced to initialize HALDB partitions that remain empty after the reload process. For more information, see the description of "YES,UNLOAD" option in [“PARTINIT control statement”](#) on page 524 and [“CHECKREC control statement”](#) on page 370.

To use this option, APAR PK48420 is required for IMS HP Load 2.1.

### **Reducing data space usage when building ILDS**

The IPR Reload utility was changed by APAR PK57505 to provide the option that reduces required data space when building ILDSs. For more information, see [“ILDSBLD control statement”](#) on page 518.

### **Support for IMS Tools KB**

The IPR Reload utility was changed by APAR PK54067 to support IMS Tools KB to store and manage reports in a central repository. For information about configuring the IMS Tools KB environment, see [“Task 2: Completing configuration for IMS Tools Knowledge Base”](#) on page 44. Some restrictions apply to using IMS Tools KB. For more information, see [“ITKBLOAD control statement”](#) on page 520.

### **IMS 11.1 support**

The IPR Reload utility was changed by APAR PK74303 to support IMS 11.1.

To use the IPR Reload utility with IMS 11, APAR PK74299 is required for IMS HP Load 2.1.



### **Segment length threshold for bitmap maintenance**

The IPR Reload utility was enhanced to change the criteria for setting flags on the bitmap blocks. You can specify a threshold value for the segment length for each database data set. For more information, see [“BMSETDSG control statement” on page 509](#).

To use this function, APAR PK73015 is required for IMS HP Load 2.1.

### **Suppression of WF1 records**

The IPR Reload utility was changed by APAR PK73016 to control whether to write WF1 records in output work data sets (DFSURWF1 and HPSRSINDX) and to change the default option for this function. For more information, see [“WF1REC control statement” on page 533](#).

To use this function, APAR PK73015 is required for IMS HP Load 2.1.

### **Sort option for HIDAM**

The IPR Reload utility was changed by APAR PK75509 to run the sort processing before loading an HIDAM database. For more information, see [“SORTHIDAM control statement” on page 530](#).

To use this function, APAR PK75509 is required for IMS HP Load 2.1.

## **The IPR DB Scan utility**

No major change has been made in the IPR DB Scan utility.

## **Changes in IMS Parallel Reorganization 3.1**

This topic describes major functional changes that were made to IMS Parallel Reorganization 3.1.

### **The IPR Driver (Smart Reorg utility)**

The following functions were added to the IPR Driver in IMS Parallel Reorganization 3.1.

The following functions were added to the IPR Driver as part of base functions of IMS Parallel Reorganization 3.1:

#### **Image copy and pointer checking during reorganization**

You can specify to take image copies and run HASH pointer checking process during an IPR Driver job. For more information, see the following topics:

- [“Image Copy processing and HASH pointer checking” on page 74](#)
- [“Considerations for Image Copy processing” on page 110](#)
- [“Considerations for HASH pointer checking” on page 114](#)

#### **Prefix resolution and update processing during reorganization**

The IPR Driver can invoke IMS HP Prefix Resolution to update the segment prefix that is involved in internal logical relationships before swapping data set names. For more information, see [“Prefix Resolution and update processing during reorganization” on page 74](#).

#### **Optional deletion of old database data sets**

You can request the IPR Driver to delete the original database data sets that were used as inputs for an IPR Driver job after the name swapping process successfully ends. A restriction applies when using this function. For more information, see [“Data sets after reorganization” on page 107](#) and [“DELOLDDS control statement” on page 135](#).

#### **Better handling of the INDEXBLD option**

The INDEXBLD control statement, which specifies to build secondary indexes, is modified to ignore INDEXBLD=YES when the database has no secondary indexes. The control statement PREFIXRES also functions the similar way. For more information, see [“INDEXBLD control statement” on page 143](#) and [“PREFIXRES control statement” on page 153](#).

#### **Parallel reorganization of selected consecutive HALDB partitions**

Multiple consecutive HALDB partitions can be reorganized by using the IPR Driver. In the IPR Driver, the number of partitions as well as the name of the partition from which the reorganization starts can

be specified in the PARTITION control statement of the (REORG) block. For more information, see [“PARTITION control statement”](#) on page 150.

### **Support of the IMSDALIB DD statement for dynamic allocation member library**

A new DD statement, IMSDALIB, is supported. The IMSDALIB DD statement is used to specify a library or libraries that contain the members for dynamic allocation generated by using the DFSMDA macro of IMS. For more information, see the description of the IMSDALIB DD statement in [“DD names common to all processing options”](#) on page 95.

The following functions were added by APARs.

### **Automated allocation of the DASD space for shadow data sets**

The IPR Driver was enhanced by APAR PK11477 to support automated allocation of the DASD space for shadow data sets. If SPACEALLOC=YES is specified, the DASD space for each shadow data set is allocated automatically. For more information, see [“SPACEALLOC control statement”](#) on page 156.

### **Easier syntax check for the related control statements**

The IPR Driver was enhanced by APAR PK11476 to simplify the syntax checking process for the related control statements. For example, if INDEXBLD=NO is specified, the control statements in the (INDEXBLD) block are ignored.

### **STEPLIB transition to the IIUBSRTx procedure for IMS Index Builder 2.3**

The IPR Driver was enhanced by APAR PK11476 to accommodate new functions that are added by APAR PK13871 to IMS Index Builder 2.3. If INDEXBLD=YES and STEPLIB=TRAN are specified, and the IIUSTEPL parameter is added to the IIUBSRTx starting procedure, the STEPLIB is transmitted to the started task instead of hard coding it in the starting procedure.

### **Selection of disposition of old database data set**

The IPR Driver was enhanced by APAR PK08740 so that the disposition for the old original database data set can be specified. For more information, see [“Data sets after reorganization”](#) on page 107 and [“DISPOLDDS control statement”](#) on page 135.

### **Naming convention for shadow secondary index data sets**

The IPR Driver was enhanced by APAR PK08740 to determine the data set names of original secondary indexes implicitly from the names of the shadow data sets that are specified in the IPR Driver job step. For more information, see the [“SINDEXSUF control statement”](#) on page 156.

### **Generation of IDCAMS control statements for manual name swapping**

The IPR Driver was enhanced by APAR PK08740 to support the generation of IDCAMS control statements for manual name swapping process. The HPSGSWAP data set can be used as SYSIN for the succeeding IDCAMS job step. For more information, see the following topics:

- The description of the HPSGSWAP DD in [“DD names common to all processing options”](#) on page 95
- [“Performing manual name swapping”](#) on page 212

### **Selection of action at name swap failure**

The IPR Driver was enhanced by APAR PK11476 so that the user can select the action to be taken at a failure in the name swap processing. For more information, see [“NAMESWAPFAIL control statement”](#) on page 148.

### **Automated DBRC processing to restore authorization flags**

The IPR Driver was enhanced by APAR PK09796 so that it can restore the DBRC flags to their original state before it terminates the processing when an error occurs during a reorganization processing. For more information, see [“Automated DBRC authorization and unauthorization processing”](#) on page 73.

### **New report that shows default option tables**

The IPR Driver was enhanced by APAR PK11734 to report the contents of the system default option table (HPSCOPTS) and the installation default option table (HPSCOPTI). For more information, see [“Default Option Tables report”](#) on page 241.

## **The IPR Unload utility**

The following functions were added to the IPR Unload utility in IMS Parallel Reorganization 3.1:



## Performance improvement

The IPR Unload utility uses Media Manager to read VSAM database data sets and to reduce CPU usage. The default buffer number for SYSUT2/3/4 output data set is raised to improve the elapsed time. The buffer is allocated above 16 MB line.

**Note:** The Media Manager is available only when the STEPLIB libraries are all APF-authorized. For more information, see [“DD statements”](#) on page 360.

## IMSDALIB DD statement support

The IPR Unload utility can use the IMSDALIB DD statement. If the library that contains the DFSMDA members for dynamic allocation is not APF-authorized, you can specify the library on the IMSDALIB DD statement.

## Selection of segments to be unloaded

The IPR Unload utility was enhanced so that it can specify the segments to be unloaded selectively. For more information, see [“SEGSEL control statement”](#) on page 385.

## Controlling output of some statistics reports

The IPR Unload utility was enhanced so that it can suppress certain statistics reports and reduce the CPU usage. For more information, see [“STATREP control statement”](#) on page 386.

## Checking correctness of randomizing

The IPR Unload utility was enhanced so that it can invoke RAPCHECK exit during unload processing. For more information, see [“RAPCHECK control statement”](#) on page 385.

## Adding extended header records in the unload data set

The IPR Unload utility was enhanced so that it can add the check record that is used by IPR Reload utility to the unload data set. For more information, see [“CHECKREC control statement”](#) on page 370.

## Support for secondary key sequence access to root segments

The IPR Unload utility was enhanced to support secondary key sequence access to HDAM or HIDAM root segments. For more information, see [“BYINDEX control statement”](#) on page 395.

## Support for user header

The IPR Unload utility was enhanced so that it can define the user header format for the record in the unload data set. For more information, see [“USERHDR control statement”](#) on page 387.

## Support for a set of non-sequential HALDB partitions

The IPR Unload utility was enhanced so that it can select a set of non-sequential HALDB partitions to process. For more information, see [“PARTITION control statement”](#) on page 383.

## Producing Largest Database Records report

The IPR Unload utility was enhanced to produce a list that contains specified number of largest database records. For more information, see [“Largest Database Records report”](#) on page 443 and [“DBRECKEYS control statement”](#) on page 371.

## Notifying the number of the retrieved database records

The IPR Unload utility was enhanced to issue the following message at the end of a database process or at each HALDB partition process.

```
HPSU3280I nnn,nnn,nnn DB RECORDS RETRIEVED - DBD=dbdname PART=ddname
```

For more information, see [“PROGMON control statement”](#) on page 384.

## The IPR Reload utility

The following functions were added to the IPR Reload utility in IMS Parallel Reorganization 3.1:

### Using High Performance I/O Driver

The IPR Reload utility was enhanced to support High Performance I/O Driver for the output database data sets. For more information, see [“HPIO control statement”](#) on page 518.

### Reloading a user-customized unload data set

The IPR Reload utility was enhanced so that it can reload the unloaded data set that contains customized segment headers by using the USERHDR control statement. For more information, see [“USERHDR control statement”](#) on page 531.

### **Ease of use by the dynamic allocation of the database data set**

The IPR Reload utility was enhanced so that the database data sets to be reloaded can be dynamically allocated. To specify the libraries that contain the members for dynamic allocation that were generated by using the DFSMDA macro of IMS, a new DD statement, IMSDALIB, is supported. It bypasses the step that needs APF authorization of the dynamic allocation library.

### **Elimination of direct I/O to OVERFLOW DD statement and POINTERS DD statement**

The IPR Reload utility was enhanced in version 3 of IMS Parallel Reorganization so that all direct I/O processing generated in OVERFLOW DD statement and POINTERS DD statement are eliminated. Unless APAR PK18989 for IMS HP Load 2.1 is applied, the OVERFLOW DD statement and the POINTERS DD statement are not used, but the data space is used instead. If any one of these DD statements is coded in a JCL stream, it will be ignored.

However, if IMS HP Load 2.1 with APAR PK18989 applied is used and HPIO=NO and OADSPR=YES options are specified, the OVERFLOW DD statement can be used to reduce data space usage. For more information, see "Reducing data space usage when reloading (P)HDAM overflow area" and "Setting the installation default option for a Reload task" in ["Changes in IMS Parallel Reorganization 3.2" on page 27.](#)

### **The IPR DB Scan utility**

No major change has been made in the IPR DB Scan utility.

## **Service updates and support information**

---

Service updates and support information for this product, including software fix packs, PTFs, frequently asked questions (FAQs), technical notes, troubleshooting information, and downloads, are available from the web.

To find service updates and support information, see the following website:

[IMS Database Reorganization Expert for z/OS](#)

## **Product documentation and updates**

---

IMS Tools information is available at multiple places on the web. You can receive updates to IMS Tools information automatically by registering with the IBM My Notifications service.

### **Information on the web**

Always refer to the IMS Tools Product Documentation web page for complete product documentation resources:

<https://www.ibm.com/support/pages/node/712955>

The IMS Tools Product Documentation web page includes:

- Links to [IBM Documentation](#) for the user guides ("HTML")
- PDF versions of the user guides ("PDF")
- Program Directories for IMS Tools products
- Technical notes from IBM Software Support, referred to as "Tech notes"
- White papers that describe product business scenarios and solutions

IBM Redbooks® publications that cover IMS Tools are available from the following web page:

<http://www.redbooks.ibm.com>

The IBM Information Management System website shows how IT organizations can maximize their investment in IMS databases while staying ahead of today's top data management challenges:

<https://www.ibm.com/software/data/ims>

## Receiving documentation updates automatically

To automatically receive emails that notify you when new technote documents are released, when existing product documentation is updated, and when new product documentation is available, you can register with the IBM My Notifications service. You can customize the service so that you receive information about only those IBM products that you specify.

To register with the My Notifications service:

1. Go to <https://www.ibm.com/support/mynotifications>
2. Enter your IBM ID and password, or create one by clicking **register now**.
3. When the My Notifications page is displayed, click **Subscribe** to select those products that you want to receive information updates about. The IMS Tools option is located under **Software > Information Management**.
4. Click **Continue** to specify the types of updates that you want to receive.
5. Click **Submit** to save your profile.

## How to send your comments

Your feedback is important in helping us provide the most accurate and highest quality information. If you have any comments about this or any other IMS Tools information, see [How to provide feedback in IBM Documentation](#).

When you provide feedback, include as much information as you can about the content you are commenting on, where we can find it, and what your suggestions for improvement might be.

## Prerequisite knowledge

Before using this information, you must understand basic IMS concepts, the IMS environment, and your installation's IMS system. Therefore, IMS publications are prerequisite for all IMS Database Reorganization Expert components.

## Related publications

This information refers to information in other publications using shortened versions of the information titles. The following table contains a list of information referred to by their short titles:

Short title used in this information	Title
<i>IMS High Performance Image Copy User's Guide</i>	<i>IBM IMS High Performance Image Copy for z/OS 4.2 User's Guide</i>
<i>IMS High Performance Load User's Guide</i>	<i>IBM IMS High Performance Load for z/OS 2.1 User's Guide</i>
<i>IMS High Performance Pointer Checker User's Guide</i>	<i>IBM IMS High Performance Pointer Checker for z/OS 3.1 User's Guide</i>
<i>IMS High Performance Prefix Resolution User's Guide</i>	<i>IBM IMS High Performance Prefix Resolution for z/OS 3.1 User's Guide</i>
<i>IMS High Performance Unload User's Guide</i>	<i>IBM IMS High Performance Unload for z/OS 1.2 User's Guide</i>
<i>IMS Index Builder User's Guide</i>	<i>IBM IMS Index Builder for z/OS 3.1 User's Guide</i>
<i>IMS Library Integrity Utilities User's Guide</i>	<i>IBM IMS Library Integrity Utilities for z/OS 2.2 User's Guide</i>
<i>IMS Tools Base Autonomics Director User's Guide and Reference</i>	<i>IBM IMS Tools Base for z/OS Autonomics Director User's Guide and Reference</i>
<i>IMS Tools Base Configuration Guide</i>	<i>IBM IMS Tools Base for z/OS Configuration Guide</i>

<b>Short title used in this information</b>	<b>Title</b>
<i>IMS Tools Base IMS Tools Common Services User's Guide and Reference</i>	<i>IBM IMS Tools Base for z/OS IMS Tools Common Services User's Guide and Reference</i>
<i>IMS Tools Base IMS Tools Knowledge Base User's Guide and Reference</i>	<i>IBM IMS Tools Base for z/OS IMS Tools Knowledge Base User's Guide and Reference</i>
<i>IMS Tools Base Policy Services User's Guide and Reference</i>	<i>IBM IMS Tools Base for z/OS Policy Services User's Guide and Reference</i>

## Accessibility features

Accessibility features help a user who has a physical disability, such as restricted mobility or limited vision, to use a software product successfully.

The major accessibility features in IMS Database Reorganization Expert enable users to perform the following activities:

- Use assistive technologies such as screen readers and screen magnifier software. Consult the assistive technology documentation for specific information when using it to access z/OS interfaces.
- Customize display attributes such as color, contrast, and font size.
- Operate specific or equivalent features by using only the keyboard. Refer to the following publications for information about accessing ISPF interfaces:
  - *z/OS ISPF User's Guide, Volume 1*
  - *z/OS TSO/E Primer*
  - *z/OS TSO/E User's Guide*

These guides describe how to use ISPF, including the use of keyboard shortcuts or function keys (PF keys), include the default settings for the PF keys, and explain how to modify their functions.

---

## Part 2. Installing and configuring IMS Database Reorganization Expert

The following topics provide detailed information about setting up and configuring IMS Database Reorganization Expert.

**Topics:**

- [Chapter 2, “Installation overview,” on page 39](#)
- [Chapter 3, “Configuring the IMS Database Reorganization Expert environment,” on page 43](#)



---

## Chapter 2. Installation overview

IMS Database Reorganization Expert is installed by using SMP/E and standard RECEIVE, APPLY, and ACCEPT processing.

Complete information about installation requirements, prerequisites, and procedures for IMS Database Reorganization Expert is located in the *Program Directory for IBM IMS Database Reorganization Expert for z/OS*.

To use IMS Database Reorganization Expert, you must complete the following steps:

1. Install the product and the prerequisite products. See the Program Directory.
2. Configure the IMS Database Reorganization Expert environment. See [Chapter 3, “Configuring the IMS Database Reorganization Expert environment,”](#) on page 43.
3. Prepare one or more policies (this step is required only if you use the conditional reorganization function.) See [“Preparing a reorganization policy”](#) on page 205.
4. Code and submit JCL streams for IMS Database Reorganization Expert utilities. See [Chapter 7, “Using the Smart Reorg utility,”](#) on page 85.

### Topics:

- [“Hardware and software prerequisites”](#) on page 39
- [“Migration considerations for IMS Parallel Reorganization users”](#) on page 40

---

## Hardware and software prerequisites

Before you install IMS Database Reorganization Expert, prepare an environment that meets the software and hardware requirements of the product.

Complete information about installation requirements, prerequisites, and procedures for IMS Database Reorganization Expert is located in the following publications:

- *Program Directory for IBM IMS Database Reorganization Expert for z/OS*
- *Program Directory for IBM IMS Database Solution Pack for z/OS*
- *Program Directory for IBM IMS Database Utility Solution for z/OS*

### Hardware prerequisites

IMS Database Reorganization Expert runs on any hardware configuration that supports the required versions of IMS.

### Software prerequisites

IMS Database Reorganization Expert operates in a z/OS environment.

#### Operating system

IBM z/OS 2.3 (5650-ZOS) or later

#### Installation requirements

IBM IMS Tools Base for z/OS 1.7 (5655-V93) or later

IBM IMS Tools Base for z/OS must be installed before IMS Database Reorganization Expert is installed. The following IBM IMS Tools Base for z/OS components are used by IMS Database Reorganization Expert:

- Autonomics Director
- Policy Services
- IMS Tools Knowledge Base

- IMS Tools Common Services (IMS Tools Online System Interface)

### **Mandatory operational requirements**

IMS Database Reorganization Expert requires one of the currently supported versions of IMS or IMS Database Value Unit Edition.

IMS Database Reorganization Expert requires the following products at their latest maintenance levels:

- IBM IMS High Performance Unload for z/OS 1.2 (5655-E06) or later
- IBM IMS High Performance Load for z/OS 2.1 (5655-M26) or later

### **Conditional operational requirements**

To use specific subfunctions of the Parallel Reorganization Service of the Smart Reorg utility, you must install these related products at their latest maintenance levels:

- To use the index building function, you must install IBM IMS Index Builder for z/OS 3.1 (5655-R01).
- To use the image copy function, you must install IBM IMS High Performance Image Copy for z/OS 4.2 (5655-N45).
- To use the HASH pointer checking function, you must install IBM IMS High Performance Pointer Checker for z/OS 3.1 (5655-U09).
- To use the prefix update and resolution function, you must install IBM IMS High Performance Prefix Resolution for z/OS 3.1 (5655-M27).
- To use the DBD decoding function or the DMB verification function, you must install IBM IMS Library Integrity Utilities for z/OS 2.2 (5655-U08).
- To use the Autonomic Director services, you must install either of the following products:
  - IBM IMS Database Solution Pack for z/OS 2.2 (5655-DSP) or later
  - IBM IMS Database Utility Solution for z/OS 2.1 (5698-DUL) or later

## **Migration considerations for IMS Parallel Reorganization users**

---

IBM IMS Database Reorganization Expert for z/OS 4.1 replaces IBM IMS Parallel Reorganization for z/OS 3.2. IMS Database Reorganization Expert supports the JCL streams that were prepared for IMS Parallel Reorganization.

### **Basic migration steps**

To migrate to IMS Database Reorganization Expert from IMS Parallel Reorganization, complete the following steps:

#### **Procedure**

1. Install IMS Database Reorganization Expert.

See the *Program Directory for IBM IMS Database Reorganization Expert for z/OS* for instructions.

2. Install IMS Tools Base for z/OS.

See the *Program Directory for IMS Tools Base for z/OS* for instructions.

3. Configure the IMS Database Reorganization Expert environment.

For the configuration steps, see [Chapter 3, “Configuring the IMS Database Reorganization Expert environment,”](#) on page 43.

### **What to do next**

When you complete these steps, the existing JCL streams for IPR Driver, IPR Unload, IPR Reload, and IPR DB Scan utilities that were used in IMS Parallel Reorganization can be used in IMS Database Reorganization Expert environment without major modifications.



If you use one or more of the following features in IMS Parallel Reorganization for z/OS, complete the additional modification steps for the STEPLIB libraries for migration:

### **IMS Tools Knowledge Base**

You must change the utility JCL stream so that the STEPLIB concatenation points to the IMS Tools KB load module library that is provided by IMS Tools Base.

### **Installation Default Option Table (HPSGOPTI)**

You must specify the library that contains the Installation Default Option Table (HPSGOPTI) in the STEPLIB concatenation for the utility JCL stream. For details about Installation Default Option Table, see [Chapter 45, “Setting installation default options,”](#) on page 617.

### **IMS Tools Online System Interface**

You must change the IPR Driver JCL stream so that the STEPLIB concatenation points to the IMS Tools Online System Interface load module library that is provided by IMS Tools Base. For details about migrating from earlier releases of IMS Tools Online System Interface, see [“Migration considerations for IMS Tools Online System Interface”](#) on page 41.

## **Migration considerations for IMS Tools Online System Interface**

If you have been using IMS Tools Online System Interface in the IPR Driver of IMS Parallel Reorganization for z/OS 3.2, you must migrate to IMS Tools Online System Interface that is included in IMS Tools Base.

### **Procedure**

Identify the release of IMS Tools Online System Interface that you have been using with IMS Parallel Reorganization 3.2.

IMS Parallel Reorganization 3.2 supports the following IMS Tools Online System Interface releases:

- FMID H2B7110 (packaged with IMS Parallel Reorganization for z/OS 3.2)
- FMID H2B7120 (packaged with other IMS Tools products. This release supersedes and deletes H2B7110.)
- FMID H32A130 (packaged with other IMS Tools products. This release supersedes and deletes H2B7110, H2B7120, H32A110, and H32A120.)

Migration steps are different based on the release of Tools Online System Interface. See the *Program Directory for IMS Tools Base for z/OS* and the *IMS Tools Base Configuration Guide* for details about installation, setup instructions, and migration considerations for IMS Tools Online System Interface.

## **Migration steps for using the Smart Reorg utility**

In IMS Database Reorganization Expert, the IPR Driver has been renamed to Smart Reorg utility, and it provides a new feature called *Conditional Reorganization Support Service* (also referred to as CRSS). This feature significantly enhances the productivity of database administrators by automating the decision-making tasks that are involved in database reorganization activities.

### **About this task**

To use this feature, modify your existing IPR Driver JCL stream as follows:

**Tip:** You can fall back the JCL stream that is modified for the CRSS to the original JCL stream by specifying CONDREORG=NO in the (REORG) block. By doing so, the control statements in the (CONDREORG) block are ignored, and the job is run in the same way that IMS Parallel Reorganization runs. If you do not want to use IMS Tools KB, you must also remove the ITKBSRVR control statement.

### **Procedure**

1. Add the load module library of IMS Tools KB to the STEPLIB library concatenation, and APF-authorize all the libraries that are specified on the STEPLIB DD statement.
  - You must use the load module library of IMS Tools KB that is provided with IMS Tools Base.

- The load module library of IMS Tools KB includes the Policy Services load modules.
- If the load module library of IMS Tools Knowledge Base for z/OS 1.1 exists in the STEPLIB concatenation, it must be removed.

See [“DD names common to all processing options” on page 95.](#)

2. Add the ITKBSRVR control statement in the (REORG) block of the JCL stream.

**Note:** If the control statement is already specified, you can skip this step.

See [“ITKBSRVR control statement” on page 144.](#)

3. Remove the ITKBLOAD control statement from your HPSIN control statement stream.

**Note:** If your HPSIN control statement stream does not include the ITKBLOAD control statement, you can skip this step.

See [“ITKBLOAD control statement” on page 144.](#)

4. Add the CONDREORG=YES statement in the (REORG) block of existing IPR Driver JCL stream.

See [“CONDREORG control statement” on page 128.](#)

5. Code the control statements in the (CONDREORG) block in the JCL stream.

See [“Control statements for the Conditional Reorganization Support Service” on page 162.](#)

# Chapter 3. Configuring the IMS Database Reorganization Expert environment

IMS Database Reorganization Expert must be configured to meet the demands of your specific environment. Without configuration and setup, the product is not fully operational.

## About this task

The configuration steps that you must complete vary based on the features of IMS Database Reorganization Expert that you use.

The following table navigates you through the configuration steps that are required before using utility features of IMS Database Reorganization Expert.

Table 1. Checklist for configuring IMS Database Reorganization Expert utilities

Task	Task description	Smart Reorg utility using the Conditional Reorganization Support Service	Smart Reorg utility without the Conditional Reorganization Support Service	IPR Unload utility or IPR Reload utility
Task 1	Configure Policy Services.	Need	N/A	N/A
Task 2	Complete the IMS Tools Knowledge Base configuration.	Need	Optional (see <a href="#">Note</a> )	Optional (see <a href="#">Note</a> )
Task 3	Verify the product information registered to IMS Tools KB.	Need	Optional (see <a href="#">Note</a> )	Optional (see <a href="#">Note</a> )
Task 4	Verify the Conditional Reorganization Support Service (CRSS) configuration.	Need	N/A	N/A
Task 5	Set up the DBRC environment.	Optional	Optional	Optional (IPR Reload utility only)
Task 6	Complete the Parallel Reorganization Service configuration.	Optional	Optional	N/A
Task 7	Change utility default options for your runtime environment.	Optional	Optional	Optional

**Note:** Task 2 and task 3 must be completed if you use the central repository of IMS Tools KB to store utility reports.

### Topics:

- [“Task 1: Configuring Policy Services for the Smart Reorg utility” on page 44](#)
- [“Task 2: Completing configuration for IMS Tools Knowledge Base” on page 44](#)
- [“Task 3: Verifying product information registered to IMS Tools KB” on page 46](#)
- [“Task 4: Verifying the CRSS environment” on page 47](#)
- [“Task 5: Setting up the DBRC environment” on page 47](#)
- [“Task 6: Configuring Parallel Reorganization Service for the Smart Reorg utility” on page 48](#)
- [“Task 7: Setting default values for your runtime environment” on page 51](#)

## Task 1: Configuring Policy Services for the Smart Reorg utility

---

Policy Services configuration is required if you plan to use the Conditional Reorganization Support Service of the Smart Reorg utility.

### About this task

For an overview of the Conditional Reorganization Support Service, see “[IMS Database Reorganization Expert features and benefits](#)” on page 18. To learn about how Policy Services is used in a Conditional Reorganization job, see [Chapter 4, “Smart Reorg utility,”](#) on page 55.

If you do not use the Smart Reorg utility or if you do not use the Conditional Reorganization Support Service, you can skip the Policy Services configuration steps.

### Procedure

To use the Conditional Reorganization Support Service, follow the steps described in "Preparing for IMS Tools Base configuration", "Configuring IMS Tools Knowledge Base", and "Configuring Policy Services" in topic "Configuration checklist for IMS Tools Base components" in the *IMS Tools Base Configuration Guide*.

While following the instructions, you will be requested to register IMS Database Reorganization Expert to IMS Tools KB and to define RECON environments. Product-specific configuration instructions for these steps are described in “[Task 2: Completing configuration for IMS Tools Knowledge Base](#)” on page 44.

## Task 2: Completing configuration for IMS Tools Knowledge Base

---

IMS Tools Knowledge Base (IMS Tools KB) must be configured if you use the Conditional Reorganization feature of the Smart Reorg utility, or if you store the reports of the Smart Reorg utility, the IPR Unload utility, or the IPR Reload utility in the central report repository that is managed by IMS Tools KB.

### Before you begin

If you do not use either of these features, you can skip these IMS Tools KB configuration steps.

If you skipped “[Task 1: Configuring Policy Services for the Smart Reorg utility](#)” on page 44 (that is, if you do not use the Conditional Reorganization feature), you must configure at least one IMS Tools KB server before starting the following configuration steps. To configure IMS Tools KB servers, follow the steps described in "Preparing for IMS Tools Base configuration" and "Configuring IMS Tools Knowledge Base" in topic "Configuration checklist for IMS Tools Base components" in the *IMS Tools Base Configuration Guide*.

### About this task

While following the checklist, you will be requested to register IMS Database Reorganization Expert to IMS Tools KB and to define RECON environments. The product-specific configuration instructions for these steps are described in the following topics.

## Task 2-1: Registering products and reports to IMS Tools KB

To use IMS Tools KB with IMS Database Reorganization Expert, you must register the product and its reports with IMS Tools KB.

### About this task

The IMS Tools KB product administration utility (HKTAPRA0) is used to register IMS Database Reorganization Expert, its prerequisite products, and their reports to IMS Tools KB. The products that need to be registered depends on the utilities and functions that are to be used.

In the following steps, a sample JCL stream for minimum registration is provided. For registration of products that are used by specific Smart Reorg function and that are not covered in the sample JCL stream, see the description on the product registration in the User's Guide of the respective product. For

detailed description about the registration utility and the general registration process, see the *IMS Tools Base Configuration Guide*.

To register the products, complete the following steps:

## Procedure

1. Modify the HPSCITKB member in the SHPSJCL0 sample JCL library.

This member contains ADDPROD statements for IMS Database Reorganization Expert, IMS HP Unload, and IMS HP Load.

**Note:** Even if any of these products are already defined in IMS Tools KB registry, the job still runs because the REPLACE option is specified.

2. Submit the modified HPSCITKB JCL to register the product IDs and their reports to IMS Tools KB.

When the job ends, the products that were successfully added to IMS Tools KB are shown.

3. Check that the job return code is zero and that the following products and their reports are listed.

```
PRODUCT ID: DA RELEASE 040100 LONG NAME: IBM IMS Database Reorganization Expert for z/OS
PRODUCT ID: DU RELEASE 010200 LONG NAME: IBM IMS HIGH PERFORMANCE UNLOAD FOR Z/OS
PRODUCT ID: DL RELEASE 020100 LONG NAME: IBM IMS HIGH PERFORMANCE LOAD FOR Z/OS
```

**Note:** If you are migrating from IMS Parallel Reorganization for z/OS, and IMS Parallel Reorganization for z/OS 3.2 is already registered to the IMS Tools KB server, the following product entry is also shown:

```
PRODUCT ID: DA RELEASE 030200 LONG NAME: IBM IMS PARALLEL REORGANIZATION FOR Z/OS
```

This is because IMS Parallel Reorganization for z/OS and IMS Database Reorganization Expert share the same product ID. You can remove the product release registration for IMS Parallel Reorganization for z/OS by following the procedure described in [“Task 3: Verifying product information registered to IMS Tools KB”](#) on page 46.

## Task 2-2: Defining RECON environments

RECON environments can be defined by using the IMS Tools KB ISPF user interface.

### Procedure

To complete this task, follow the instructions in the topic "RECON ID (locale) administration" in *IMS Tools Base Configuration Guide*

If you are configuring IMS Tools KB to use the Conditional Reorganization feature of the Smart Reorg utility, the following RECON IDs must also be added to IMS Tools KB:

- Recon ID: \$IVP
- Recon1: \$rgeivp.IVP.RECON1
- Recon2: \$rgeivp.IVP.RECON2
- Recon3: \$rgeivp.IVP.RECON3

This RECON ID definition will be used in the setup verification jobs in [“Task 4: Verifying the CRSS environment”](#) on page 47. The high-level qualifier \$rgeivp for the RECON data sets defined for this RECON ID must match the qualifiers that will be used for RECON data sets for the setup verification jobs.

## Task 2-3: Requesting utility jobs store reports to the IMS Tools KB repository

To request a utility of IMS Database Reorganization Expert store reports to the IMS Tools KB Output repository, you must specify the name of the IMS Tools KB server XCF group to the ITKBSRVR control statement for each utility job.

### Procedure

The ITKBSRVR control statement directs the utility to communicate with the IMS Tools KB server so that the utility reports are stored in the Output repository.

For details of this control statement for each utility, see the following topics:

- For the Smart Reorg utility, see [“ITKBSRVR control statement” on page 144](#).
- For the IPR Unload utility, see [“ITKBSRVR control statement” on page 374](#).
- For the IPR Reload utility, see [“ITKBSRVR control statement” on page 521](#).

**Tip:** You can set this option as the system default at your installation. For the task related with this configuration, see [“Task 7: Setting default values for your runtime environment” on page 51](#).

## Task 3: Verifying product information registered to IMS Tools KB

---

When you complete the registration of IMS Database Reorganization Expert with IMS Tools KB, you must check and confirm the registered information, which includes the retention setting information for the reports.

### Procedure

Complete this task by using the reports service ISPF user interface of IMS Tools KB.

1. Start the ISPF interface.

For more information about starting the ISPF user interface, see the topic "Starting the report service user interface" in the *IMS Tools Base Configuration Guide*.

2. Select the **Administration** pull down menu on the main panel.
3. Select option 2, **List Installed Products** to show the Installed Product List panel.
4. In the **Installed Product List** panel, ensure that the following product entries exist:

- Product Name: IBM IMS Database Reorganization Expert for z/OS, Product Release: 040100
- Product Name: IBM IMS HIGH PERFORMANCE LOAD FOR Z/OS, Product Release: 020100
- Product Name: IBM IMS HIGH PERFORMANCE UNLOAD FOR Z/OS, Product Release: 010200

If you already have registered IMS Parallel Reorganization for z/OS 3.2 to this IMS Tools KB server, the panel also shows the following entry because IMS Database Reorganization Expert is the successor product of IMS Parallel Reorganization.

- Product Name: IBM IMS PARALLEL REORGANIZATION FOR Z/OS, Product Release: 030200

You can remove this entry by using the Row Action command **RR** (Remove Release command).

**Caution:** You must not use the **RS** (Remove Subscription) command or the **RP** (Remove Product) command. If you use either of these commands, all subscription to all the reports will be removed and all existing report instances for IMS Parallel Reorganization will be deleted from the Output repository.

5. If necessary, change the retention setting for the registered reports.

Check the retention setting for the registered reports. If you want to change the retention setting for the reports, follow the instructions in the topic "Report administration" in the *IMS Tools Base IMS Tools Knowledge Base User's Guide and Reference*.

## Task 4: Verifying the CRSS environment

---

You can use the setup verification procedure jobs to verify that your IMS Tools KB and Policy Services environment is correctly configured for the Conditional Reorganization Support Service (CRSS) of the Smart Reorg utility.

### Procedure

To verify the CRSS environment, complete the following steps:

**Tip:** You can find more information about these jobs in the instructions that are provided in each JCL member.

1. Run the HPSCIVPA job.

This job prepares the test environment by allocating all the data sets that are used in the test, and loading test data into these data sets.

If you are a JES3 user, edit and submit member HPSCIVP0 in the SHPSJCL0 library before executing HPSCIVPA.

2. Run the HPSCIVPC job.

This job runs a conditional reorganization job of the Smart Reorg utility.

If you did not register the RECON ID information in “[Task 2-2: Defining RECON environments](#)” on page 45, the Smart Reorg utility job issues messages HPSG2212W and BBE0304W, and ends with return code of 04.

3. Check the job output.

When the HPSCIVPC job ends, check the WTO messages. If you receive the following messages, your IMS Tools KB and Policy Services environment is correctly configured:

```
- HPSG2314I REORGANIZATION IS NOT NEEDED FOR DATABASE DEVICEDB
- BBE0316A  DIAGNOSIS REPORT IS STORED IN REPOSITORY WITH REPORT COMPLETION CODE OF 016
- HPSG0010I CONDREORG FUNC ENDED FOR DATABASE DEVICEDB (RC=00)
```

**Note:** Report completion code of 16 that is shown in message BBE0316A is the expected result when the job ends successfully.

If you receive any error messages, see “[Identifying problems in Smart Reorg jobs](#)” on page 655.

4. Run the HPSCIVPD job.

This job cleans up the test environment by deleting all the test data sets.

## Task 5: Setting up the DBRC environment

---

The Smart Reorg utility and the IPR Reload utility issue IMS DBRC commands and API requests. To enable certain DBRC functions, complete the following configuration steps.

### Setting up the DBRC command authorization

You can use the DBRC Command Authorization function in Smart Reorg utility and IPR Reload utility runs.

### Procedure

The user ID under which the Smart Reorg utility or the IPR Reload utility runs must be authorized to access resources for certain DBRC commands and API requests. Such resources are listed in the following tables.

Table 2. DBRC command authorization for the Smart Reorg utility

Resource	Description
<i>hlq.CHANGE.DB.dbname</i>	Issued only when one of NAMESWAP=YES, DBRCAUTHCMD=YES, or IMSCMD=YES is specified.
<i>hlq.CHANGE.IC.dbname</i>	Might be issued only when IC=YES and NAMESWAP=YES are specified.
<i>hlq.LIST.DB.dbname</i>	Always issued.
<i>hlq.LIST.RECON</i>	Always issued.
<i>hlq.LIST.SUBSYS.ALL</i>	Issued only when IMSCMD=YES is specified.
<i>hlq.NOTIFY.IC.dbname</i>	Issued only when both IC=YES and NAMESWAP=YES are specified.
<i>hlq.NOTIFY.REORG.dbname</i>	Issued only when NAMESWAP=YES is specified.
<i>hlq.NOTIFY.UIC.dbname</i>	Might be issued only when NAMESWAP=YES is specified.
<i>hlq.STDBRC</i>	Always issued.

Table 3. DBRC command authorization for the IPR Reload utility

Resource	Description
<i>hlq.LIST.DB.dbname</i>	Always issued.
<i>hlq.LIST.RECON</i>	Issued only when processing a HALDB OSAM database.
<i>hlq.STDBRC</i>	Issued only when processing a HALDB OSAM database.

For more information about authorizing user IDs, see the topic "Security for DBRC commands and API requests" in *IMS System Administration*.

## Setting up the DBRC SCI registration exit routine

To enable automatic RECON loss notification or parallel RECON access, you must specify an IMSplex name that identifies the RECON data set to be used. This can be done by using the DBRC SCI Registration exit routine (DSPSCIX0) or the EXEC statement keyword parameter IMSPLEX= for the subject utility.

### Procedure

If more than one set of RECONS is defined in the IMSPLEX, the DBRC sharing group (DBRC group ID) also needs to be specified either in the DSPSCIX0 exit routine or by the EXEC statement keyword parameter DBRCGRP= for the subject utility.

## Task 6: Configuring Parallel Reorganization Service for the Smart Reorg utility

The Parallel Reorganization Service of the Smart Reorg utility provides various optional features that simplify database reorganization jobs.

### Before you begin

For the overview of the Parallel Reorganization Service, see "[IMS Database Reorganization Expert features and benefits](#)" on page 18.

If you do not use the Smart Reorg utility, you can skip these steps.



## Procedure

The Parallel Reorganization Service does not require configuration. However, by configuring and enabling the following optional features, you can significantly reduce the manual tasks required for database reorganization.

### To enable the index building function in parallel reorganization processing

Configure the IMS Index Builder product by following the steps in [“Setting up IMS Index Builder” on page 49](#).

### To enable the Automated IMS Command Processing function

Select the method to use and follow the configuration steps. Two methods are provided:

- Using the IMS Tools Online System Interface

If IMSCMD=YES,TOSI is specified, the IMS Tools Online System Interface (TOSI) is used.

If you want to use the database automatic restart function, you must use the IMS Tools Online System Interface.

For information about setting up the IMS Tools Online System Interface, follow the configuration steps in the *IMS Tools Base Configuration Guide*.

If you are migrating from IMS Parallel Reorganization for z/OS, see also [“Migration considerations for IMS Tools Online System Interface” on page 41](#).

- Using the E-MCS console interface

To enable the Automated IMS command processing function for E-MCS console, follow the steps in [“Setting up for using E-MCS console for IMS command processing” on page 50](#).

If you specify IMSCMD=YES or IMSCMD=YES,EMCS in HPSIN DD statement for the Smart Reorg utility, the Smart Reorg utility issues IMS commands internally to deallocate the databases from IMS online subsystems or make them read-only status for the use of IMS online subsystems before the reorganization begins.

In this case, the Smart Reorg utility uses the Extended Multiple Console Support (E-MCS) of IMS to issue IMS commands internally. You need to specify the CMDMCS= parameter in your procedure to start IMS online subsystems to allow commands to be entered at the E-MCS console created by the Smart Reorg utility.

## Setting up IMS Index Builder

An index building task can be included in the Smart Reorg job step.

To include an index building task in the Smart Reorg job step, IMS Index Builder is required. This topic describes how to set up IMS Index Builder.

Subsections:

- [“Basic setup” on page 49](#)
- [“Setting up security for image copy data sets” on page 50](#)

### Basic setup

If you want to use the Smart Reorg utility to reorganize a database that has one or more secondary indexes and to rebuild the secondary indexes by specifying INDEXBLD=YES or PSINDEXBLD=YES, you must install IMS Index Builder. The load module library of IMS Index Builder must be concatenated to the STEPLIB or JOBLIB. In addition, you must customize the IIUBSRT procedure of IMS Index Builder that is used for starting the SORT address space.

For more information about setting up IMS Index Builder, see the *IMS Index Builder User's Guide*.

If Type-A Image Copy is activated for secondary indexes of a non-HALDB, IMS HP Image Copy and IMS HP Pointer Checker run in the SORT subordinate address space started by IMS Index Builder. You do not need to add the DD statements for the libraries of IMS HP Image Copy and IMS HP Pointer Checker

to the STEPLIB DD concatenation in the subordinate address space procedure (IIUBSRT) because DD statements for such libraries are allocated dynamically.

## Setting up security for image copy data sets

Considerations and recommendations for security settings for accessing index data sets, which are described in the *IMS Index Builder User's Guide*, also apply to the image copy data sets of secondary indexes that are created by Type-A Image Copy.

Unless you allocate space for the image copy data set of secondary index in a preceding job step or in another job, the space for the image copy data set is dynamically allocated in a SORT subordinate address space started by IMS Index Builder. In this case, the ALTER authority is necessary for the started task. The default job name of the started task is IIUSORTS. You can override the job name in the runtime parameters module provided by IMS Index Builder.

If the space is allocated before the Smart Reorg utility job is run, the CONTROL authority is enough. But, in this case, you cannot use the tape or GDG for image copy data sets. The ALTER authority is required for image copies that are generated in a GDG data set or on a tape.

For details about security setting of started tasks, see the topic that describes how to associate started procedures and jobs with user IDs in the *z/OS Security Server RACF System Programmer's Guide* and in the *z/OS Security Server RACF Security Administrator's Guide*.

## Setting up for using E-MCS console for IMS command processing

You can request Smart Reorg utility, Pre-reorganization utility, and Post-reorganization utility jobs to issue some IMS commands through the E-MCS console interface.

Subsections:

- [“CMDMCS= parameter” on page 50](#)
- [“Command security” on page 50](#)
- [“User ID for E-MCS console” on page 51](#)
- [“IMS commands issued through the E-MCS console” on page 51](#)
- [“Authorization to use the MCSOPER macro” on page 51](#)

### CMDMCS= parameter

IMS DB/DC and DBCTL systems allow commands to be entered at MCS/E-MCS consoles by specifying execution parameter keyword CMDMCS with a value other than N. You can specify one of the following values:

**Y**

All commands that are allowed with CRC (DB/DC systems only).

**R**

RACF® command security.

**C**

DFSCCMD0 command security.

**B**

RACF and DFSCCMD0 command security.

### Command security

You can use either or both of the following command security protections provided by IMS:

- RACF or its equivalent security product
- IMS Command Authorization Exit routine (DFSCCMD0)

For a detailed description, see *IMS System Administration* and *IMS Exit Routines*.

## User ID for E-MCS console

HPSGMAIN is the user ID used for the E-MCS console of the Smart Reorg utility, and HPSCMAIN is the user ID used for the E-MCS console of the Pre-reorganization utility and the Post-reorganization utility. Grant authorization to these user IDs so that IMS commands are accepted by the IMS subsystem.

## IMS commands issued through the E-MCS console

The Smart Reorg utility, the Pre-reorganization utility, and the Post-reorganization utility issue the following IMS commands:

- /DBR commands to deallocate databases from IMS online subsystems
- /DBD commands to make databases read-only status for the use of IMS online subsystems

## Authorization to use the MCSOPER macro

The Smart Reorg utility, the Pre-reorganization utility, and the Post-reorganization utility internally use the MVS™ MCSOPER macro to activate the E-MCS console. You must have read access for MVS.MCSOPER.\* RACF profile to issue the MCSOPER macro. Otherwise, the job abends with code 3103 and message HPSG3103E, showing return code 0C from the MCSOPER macro.

## Task 7: Setting default values for your runtime environment

---

You can change the default values for your runtime environment by using the Default Option Table (HPSCOPTI).

### About this task

For example, you can specify the IMS Tools KB server name in the Default Option Table (HPSCOPTI). If the IMS Tools KB server name is specified in the Default Option Table, this specification is treated as the default option for your runtime environment. In this way, you do not need to specify the ITKBSRVR control statement in each utility job to activate the IMS Tools KB capability.

You can also change some other system default options for each utility by using the Default Option Table. For details, see [Chapter 45, “Setting installation default options,” on page 617](#). Also see [Chapter 44, “Performance tips and considerations,” on page 609](#) to learn how you can use the Default Option Table to improve the performance of IMS Database Reorganization Expert jobs.



---

## Part 3. Reorganizing a database in one job step

The following topics explain how to reorganize a database in one job step by using the Smart Reorg utility.

**Topics:**

- [Chapter 4, “Smart Reorg utility,” on page 55](#)
- [Chapter 5, “Conditional Reorganization Support Service,” on page 61](#)
- [Chapter 6, “Parallel Reorganization Service,” on page 69](#)
- [Chapter 7, “Using the Smart Reorg utility,” on page 85](#)
- [Chapter 8, “Smart Reorg JCL requirements,” on page 89](#)
- [Chapter 9, “Smart Reorg control statements,” on page 117](#)
- [Chapter 10, “Smart Reorg examples,” on page 181](#)
- [Chapter 11, “Working with policies and database exceptions,” on page 205](#)
- [Chapter 12, “Preparing and completing reorganization,” on page 211](#)
- [Chapter 13, “Smart Reorg reports,” on page 217](#)



---

## Chapter 4. Smart Reorg utility

The Smart Reorg utility provides the database status evaluation, exception reporting, and reorganization functions for IMS full-function databases.

### Topics:

- [“Smart Reorg overview” on page 55](#)
- [“Programs and services used in Smart Reorg utility jobs” on page 56](#)
- [“Process flow of the Smart Reorg utility” on page 57](#)
- [“Smart Reorg restrictions and requirements” on page 58](#)

---

### Smart Reorg overview

A Smart Reorg utility job is controlled by the *Smart Reorg Driver*. It uses the Conditional Reorganization Support Service and the Parallel Reorganization Service to conditionally reorganize an IMS full-function database.

By using only one of the services or both, the Smart Reorg utility provides the following four runtime modes:

#### Conditional Reorganization mode

When you run the Smart Reorg utility in this mode, the Smart Reorg Driver invokes the Conditional Reorganization Support Service to evaluate the database.

When the Conditional Reorganization Support Service determines that the database needs to be reorganized, the Smart Reorg Driver invokes the Parallel Reorganization Service to reorganize the database. When the reorganization process completes, the Conditional Reorganization Support Service is called to evaluate the reorganized database and to report the processing result and the status of the database before and after reorganization.

When the Conditional Reorganization Support Service determines that the database does not need to be reorganized, it reports the current database status and ends the job.

Conditional Reorganization mode is useful when you do not know the database status and you want to reorganize the database only if database reorganization is needed.

#### Unconditional Reorganization mode

When you run the Smart Reorg utility in this mode, the Smart Reorg Driver invokes the Parallel Reorganization Service to reorganize the database. The Conditional Reorganization Support Service is not invoked and the database is reorganized every time a job is run in this mode.

Use Unconditional Reorganization mode when you already know the status of the database or when you want to reorganize the database regardless of its status.

#### Reorganization Diagnosis mode

When you run the Smart Reorg utility in this mode, the Smart Reorg Driver invokes the Parallel Reorganization Service to reorganize the database and the Conditional Reorganization Support Service. The Conditional Reorganization Support Service evaluates the reorganized database and reports the processing results and the status of the database before and after reorganization. Although the Conditional Reorganization Support Service is invoked, the database is reorganized every time a job is run in this mode.

Use Reorganization Diagnosis mode when you want to reorganize the database and want to compare the database status before and after reorganization. You can also obtain a list of exceptions that remained after the reorganization.

#### Diagnosis-only mode

When you run the Smart Reorg utility in this mode, the Smart Reorg Driver invokes the Conditional Reorganization Support Service to evaluate the database and to report the database status. The Parallel Reorganization Service is not invoked, which means that the reorganization process is not run.

Use Diagnosis-only mode to check the database status.

The following table summarizes the features of the four runtime modes.

*Table 4. Runtime modes of the Smart Reorg utility*

<b>Mode</b>	<b>CRSS is called?</b>	<b>Database is reorganized?</b>	<b>Diagnosis report is generated?</b>
Conditional Reorganization mode	Yes	Only when needed as determined by CRSS	Yes
Unconditional Reorganization mode	No	Yes	No
Reorganization Diagnosis mode	Yes	Yes	Yes
Diagnosis-only mode	Yes	No	Yes

Use the CONDREORG control statement to specify which runtime mode to use. The CONDREORG control statement specifies whether the Smart Reorg Driver is to use the Conditional Reorganization Support Service and how it is to be used.

### **Related concepts**

#### Conditional Reorganization Support Service

The Conditional Reorganization Support Service (CRSS) evaluates a database, determines if the database needs to be reorganized, and reports the database status.

#### Parallel Reorganization Service

The Parallel Reorganization Service is the database reorganization service provided by the Reorganization Manager of the Smart Reorg utility. This service enables you to reorganize HISAM, SHISAM, HDAM, HIDAM, PHDAM, or PHIDAM database in a single job step.

### **Related reference**

#### CONDREORG control statement

Specifies whether to enable the Conditional Reorganization Support Service (CRSS).

## **Programs and services used in Smart Reorg utility jobs**

The Smart Reorg utility uses the following programs and services.

### **Smart Reorg Driver**

The Smart Reorg Driver program controls the entire Smart Reorg job by invoking the Parallel Reorganization Service, the Conditional Reorganization Support Service, or both.

### **Parallel Reorganization Service**

The Parallel Reorganization Service controls the entire reorganization process by invoking the unload engine (HSSR Engine) of IMS HP Unload and the reload engine of IMS HP Load. It also uses functions that are provided by other IMS Tools products to run designated optional tasks when specified.

### **Conditional Reorganization Support Service (CRSS)**

The CRSS collects the database space statistics, evaluates the statistics based on the specified reorganization policy, determines the reorganization need, and evaluates the reorganization effect. IMS Tools KB and Policy Services are used extensively throughout this process.

### **Policy Services**

Policy Services provides sensor data store and read services and policy definition and management services. These services are internally used by the CRSS for evaluating database status. This component is provided by IMS Tools Base.

### **IMS Tools KB server and repositories**

IMS Tools KB server and its services provide the capability to centrally manage various repositories that are used by IBM IMS Tools products. The following repositories are used in a typical Smart Reorg job:



### Input repository

This repository is used to store and manage policies, rules, notification lists, and the RECON environment information.

### Output repository

This repository is used to store and manage reports produced by IMS Tools products.

### Sensor Data repository

This repository is used to store the database statistics collected by the DB Sensor component of the CRSS.

This component is provided by IMS Tools Base.

### IMS Tools KB report service

The IMS Tools KB report service stores Smart Reorg reports in the Output repository of the IMS Tools KB server. This service is provided by IMS Tools Base.

## Process flow of the Smart Reorg utility

The following diagram illustrates the internal process flow of a Smart Reorg utility job that runs in Conditional Reorganization mode.

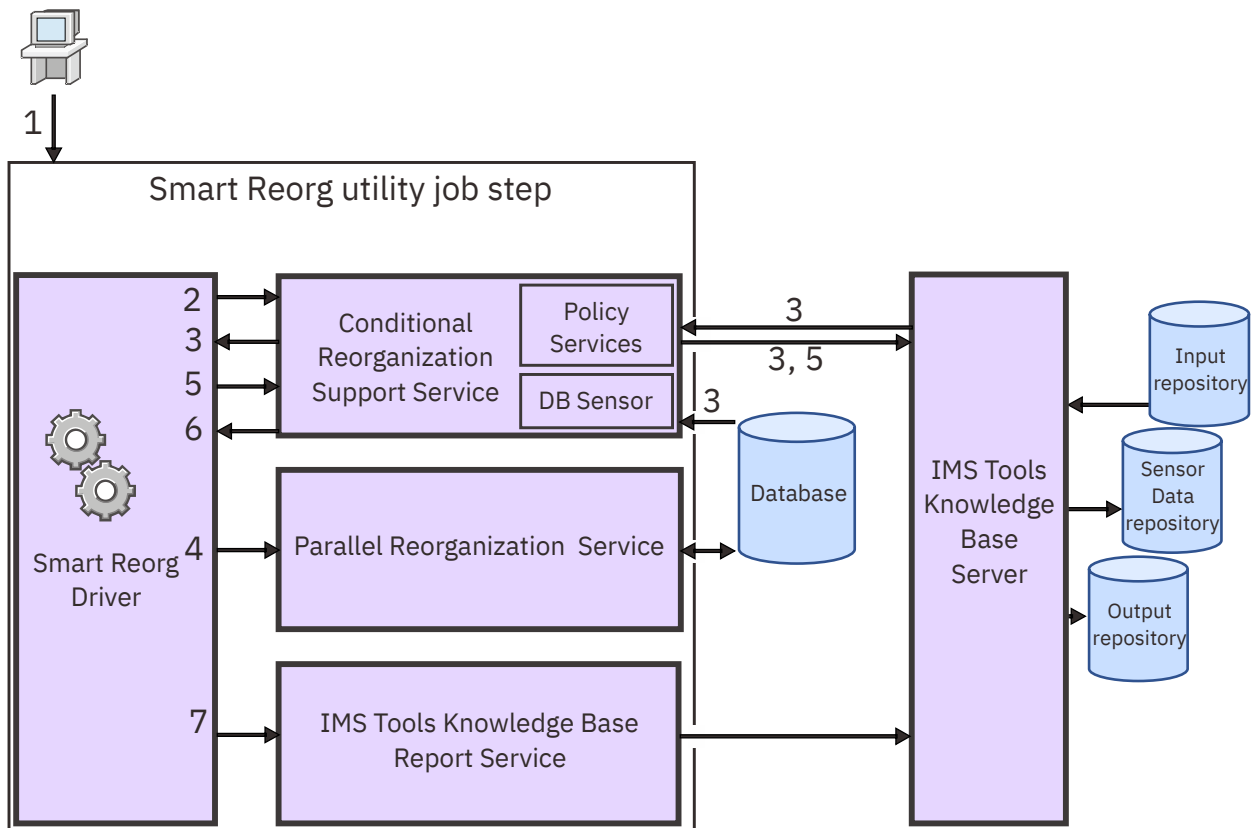

Figure 2. Internal process flow for a Smart Reorg utility job

The following process flow steps match the numbers in the diagram:

1. A user submits a Smart Reorg job.
2. The Smart Reorg Driver calls the CRSS.
3. The CRSS requests Policy Services to retrieve the reorganization policy, collect the database statistics, and evaluate the statistics by using the policy. Then, the CRSS returns the result to the Smart Reorg Driver.
4. If database reorganization is recommended by the CRSS, the Smart Reorg Driver calls the Parallel Reorganization Service to reorganize the database using shadow data sets. If database reorganization

is not recommended by the CRSS, the Smart Reorg Driver process continues with step [“7” on page 58](#).

5. The Smart Reorg Driver requests the CRSS to store the database statistics that were collected during the reorganization reload process.
6. The CRSS requests Policy Services to evaluate the database statistics of the reorganized database by using the same reorganization policy, and returns the result to the Smart Reorg Driver.
7. The Smart Reorg Driver requests the IMS Tools KB Report Service to send all the reports that are generated within the job to the IMS Tools KB server.

## Smart Reorg restrictions and requirements

---

Some restrictions apply to using the Smart Reorg utility.

Subsections:

- [“Common restrictions” on page 58](#)
- [“Unconditional Reorganization mode restrictions” on page 58](#)
- [“Conditional Reorganization mode and Reorganization Diagnosis mode restrictions” on page 59](#)
- [“Diagnosis-only mode restrictions and requirements” on page 59](#)

### Common restrictions

Only one database (DBD) can be processed in a single Smart Reorg job in any mode.

### Unconditional Reorganization mode restrictions

- Building shared secondary indexes is not supported because IMS Index Builder does not support them. For more information, see the *IMS Index Builder User's Guide*.
- Checkpoint and restart capability is not provided.
- User-written Data Conversion exit routines are not supported.
- The Smart Reorg Driver supports only a subset of the control statements of the stand-alone IPR Unload utility, the IPR Reload utility, IMS Index Builder, the Concurrent Prefix Update of IMS HP Prefix Resolution, and IMS HP Image Copy. The system default values of some parameters for the Image Copy task are different from those for the stand-alone IMS HP Image Copy. For a list of supported control statements, see [“Control statements for the Smart Reorg Driver” on page 118](#).
- Any limitations of the stand-alone utilities are also limitations of the Smart Reorg utility.
- Certain characteristics of a DBD cannot be changed between the unload process and the reload process. For details, see [“NEWDBD control statement” on page 149](#).
- The following restrictions apply to IMS HP Image Copy processing:
  - The following database organizations are not supported:
    - HDAM or HIDAM databases that have external logical relationships that need Prefix Resolution and Update.
    - HISAM databases that have logical relationships because IMS HP Prefix Resolution does not support such databases. For details, see [“External logical relationships of HDAM and HIDAM” on page 109](#), [“Logical relationship of HISAM” on page 110](#), and [“Logical relationships that do not require Prefix Resolution and Update” on page 110](#).
  - Type-A Image Copy does not support the image copy stacking feature. Use Type-B Image Copy if you want to stack image copies.
  - Type-A Image Copy cannot be used if PSINDEXes are built with the PSINDEXBLD=YES option. Use Type-B Image Copy if you want to build PSINDEXes.
- IMS catalog databases are not supported.

## Conditional Reorganization mode and Reorganization Diagnosis mode restrictions

- All restrictions in [“Diagnosis-only mode restrictions and requirements” on page 59](#) and in [“Unconditional Reorganization mode restrictions” on page 58](#) apply when running the job in Conditional Reorganization mode or in Reorganization Diagnosis mode.
- Unload data set cannot be used as the input for reorganization in Conditional Reorganization mode or in Reorganization Diagnosis mode. When the Smart Reorg utility runs the reorganization process in a job that runs in these modes, it unloads segment data from the database for the reorganization. Therefore, you must ensure that DASD space for shadow data sets is always available during the parallel reorganization phase.
- For HALDBs, only a single partition can be processed in a single Smart Reorg job that runs in Conditional Reorganization mode or in Reorganization Diagnosis mode.
- DBD changes are not allowed in Conditional Reorganization mode or in Reorganization Diagnosis mode.

## Diagnosis-only mode restrictions and requirements

- The use of IMS Tools KB is mandatory.
- All STEPLIB libraries must be APF-authorized.
- For a database that uses VSAM data sets, SHAREOPTIONS other than (1,3) must be specified for each VSAM data set of the database.
- When DB Sensor collects sensor data from an online database, the collected data element values might not reflect the latest database condition. For a list of data elements that have the potential of not storing the latest data, see [“Considerations for collecting sensor data from a database that is being updated” on page 66](#)



---

# Chapter 5. Conditional Reorganization Support Service

The Conditional Reorganization Support Service (CRSS) evaluates a database, determines if the database needs to be reorganized, and reports the database status.

## Topics:

- [“What is the Conditional Reorganization Support Service?” on page 61](#)
- [“Data and process flow of the CRSS” on page 62](#)
- [“Reorganization policy overview” on page 64](#)

---

## What is the Conditional Reorganization Support Service?

The Conditional Reorganization Support Service (CRSS) provides database administrators the ability to automate the decision-making tasks that are involved in database reorganization. It evaluates the database and determines whether reorganization is needed for the database.

The CRSS uses a reorganization policy to evaluate a database and to determine if it needs to be reorganized. A reorganization policy contains criteria for evaluating database statistics and can be customized to set specific criteria. The policies can be customized and managed through the ISPF user interface that is provided by Policy Services.

The CRSS is supported for the Smart Reorg utility and IMS Database Solution Pack: IMS Online Reorganization Facility (also referred to as IMS Online Reorganization Facility).

When a Smart Reorg job or IMS Online Reorganization Facility job is run in Conditional Reorganization mode, the job goes through the following phases:

### 1. First evaluation phase

In the first evaluation phase, the CRSS collects the statistics data from the target database and evaluates the statistics data by using the criteria that is defined in the reorganization policy to detect database exceptions. Based on the exceptions that are detected, the policy determines whether the database needs to be reorganized. Then, the CRSS returns the result to the Smart Reorg Driver or IMS Online Reorganization Facility.

### 2. Reorganization phase

- When the Smart Reorg Driver receives recommendation to reorganize the database or some HALDB partitions from the CRSS, it invokes the Parallel Reorganization Service, and the reorganization process is run. During the reorganization reload process, some statistics of the reloaded shadow data sets are collected by the CRSS.
- When IMS Online Reorganization Facility receives recommendation to reorganize the database from the CRSS, it starts the reorganization process.

### 3. Second evaluation phase

When the reorganization process ends and the database reorganization is committed, the CRSS collects some additional statistics data about the reorganized database, and commits all statistics data that it collected during the reload process and after reorganization. Then, the CRSS evaluates the data by using the same policy that was used in the first evaluation phase to detect any remaining database exceptions.

- For the Smart Reorg utility, if automatic post-reorganization processing is not requested, the CRSS collects the database statistics from the shadow data sets.
- For IMS Online Reorganization Facility, after the reorganized database is started in the takeover phase, the CRSS collects the database statistics from the reorganized database.

### 4. Reporting phase

The CRSS generates a Diagnosis report that shows the detected database exceptions, database statistics from before and after reorganization, and a summary of the job, and stores the report in a central repository that is managed by IMS Tools KB. When reorganization is not processed (that is, in the first evaluation phase when the policy determined that the database did not need to be reorganized) the CRSS generates a Diagnosis report that summarizes the detected database exceptions (if any) and the statistics of the database.

In this phase, notification messages about the result of the policy evaluation can optionally be sent to designated TSO users and designated z/OS consoles.

When a Smart Reorg job is run in Conditional Reorganization mode, optionally the Smart Reorg job can create an unload data set without reorganizing the database. When this happens, a specific return code is passed to the succeeding job step to run the database reorganization in the succeeding job step.

When a Smart Reorg job is run in Diagnosis-only mode, the job goes through only the first evaluation phase and the reporting phase.

When a Smart Reorg job is run in Conditional Reorganization mode or in Reorganization Diagnosis mode and internal errors occur in CRSS processing, the Smart Reorg Driver invokes the Parallel Reorganization Service to reorganize the database without considering the evaluation result that is returned from the CRSS. This mechanism prevents the possibility that a required reorganization is accidentally skipped because of an internal error in the CRSS. When a Smart Reorg job is run in Diagnosis-only mode and internal errors occur in CRSS processing, the Smart Reorg Driver ends the job and issues error messages.

### **Related concepts**

What is a policy?

A *policy* is the expression, or definition, that is used by Policy Services to evaluate specific database states, such as the state of space utilization at a specific instance in time.

### **Related reference**

CONDREORG control statement

Specifies whether to enable the Conditional Reorganization Support Service (CRSS).

BBERPRT data set: Diagnosis report

The BBERPRT data set contains Diagnosis reports that are generated by conditional reorganization jobs.

## **Data and process flow of the CRSS**

---

This topic explains data and process flow of the Conditional Reorganization Support Service.

Subsections:

- [“Components used in the CRSS” on page 62](#)
- [“Component interactions with the CRSS” on page 63](#)

### **Components used in the CRSS**

The following components and services are used by the CRSS if the job runs in Conditional Reorganization mode, in Reorganization Diagnosis mode, or in Diagnosis-only mode:

#### **DB Analyzer**

To realize database diagnosis and conditional reorganization, the DB Analyzer component controls the entire flow of the CRSS operations by calling the DB Sensor component and Policy Services. The CRSS operations include initiating statistics data collection, requesting statistics data evaluation with a designated policy, and summarizing and reporting the processing result.

#### **DB Sensor**

The DB Sensor component collects the database statistics data from the database and stores the data as sensor data in the Sensor Data repository of IMS Tools KB server.

#### **Sensor data service**

Sensor data is the data collected by DB Sensor while it measures the condition (or state) of the database. This component is provided by the IMS Tools Base.

## Policy Services

Policy Services manages the reorganization policies. Policies consist of a set of rules that each define threshold limits for specific types of database conditions. The Policy Services mechanism evaluates these threshold limits against actual data that DB Sensor collects and stores in the IMS Tools KB Sensor Data repository. It also provides the exception notification function. This component is provided by the IMS Tools Base.

## IMS Tools KB server and repositories

By using a set of repositories, IMS Tools KB server and its services provide capability to centrally manage various information that is generated by IMS Tools products and to share them across the products. The following repositories are extensively used in Smart Reorg jobs and IMS Online Reorganization Facility jobs:

### Input repository

This repository is used to store and manage policies, rules, and the RECON environment information.

### Output repository

This repository is used to store and manage reports produced by IMS Tools products.

### Sensor Data repository

This repository is used to store the database statistics collected by DB Sensor.

This component is provided by the IMS Tools Base.

## ISPF user interfaces

The following two ISPF user interfaces are provided by IMS Tools Base:

- An ISPF user interface that allows you to customize and manage policies, rules, and notification lists that are stored in the Input repository
- An ISPF user interface that allows you to search, view, and manage reports that are stored in the Output repository

## Component interactions with the CRSS

The following diagram illustrates the interactions between the components that are used in a conditional reorganization job.

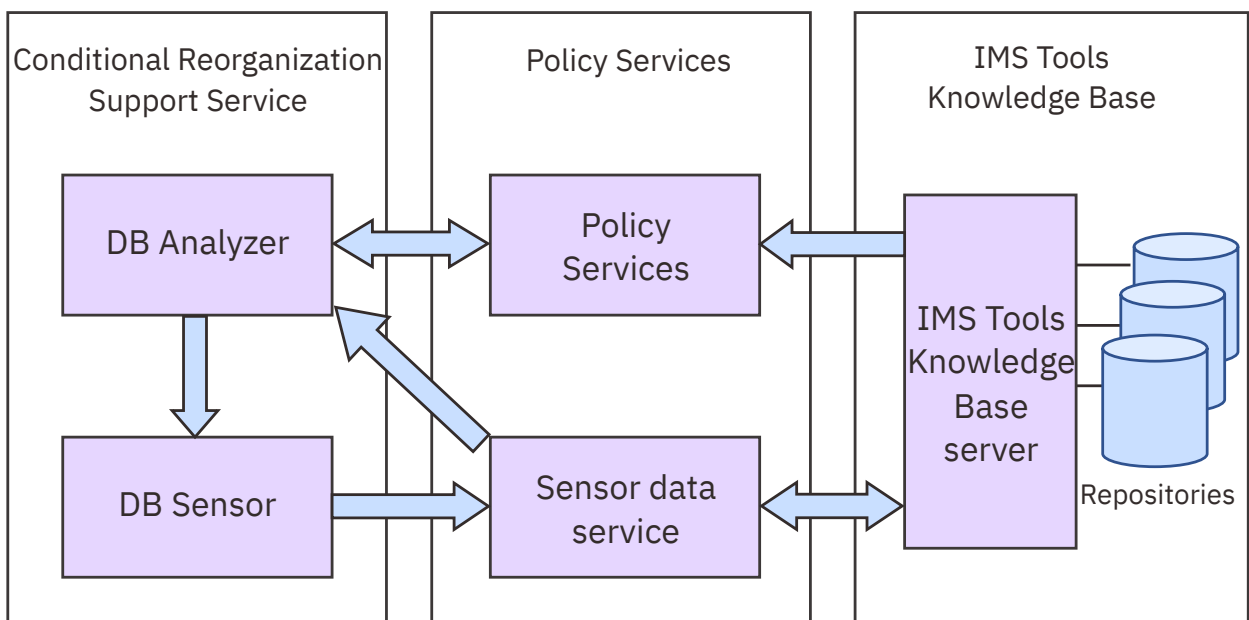

Figure 3. Component interactions with the Conditional Reorganization Support Service

Sensor data can be collected and stored by the jobs of IMS HP Pointer Checker, IMS HP Image Copy, and FF Stand-alone DB Sensor. The latest sensor data that was collected by these jobs can be used by the CRSS in the following policy evaluation processes:

- The first evaluation phase in Conditional Reorganization mode and in Reorganization Diagnosis mode
- Diagnosis-only mode

## Reorganization policy overview

---

Policy Services is a generalized service that allows you to influence the behavior of IMS Tools by using simple or complex expressions.

### Related tasks

[Preparing a reorganization policy](#)

Before you run a Smart Reorg utility job in Conditional Reorg mode, Reorganization Diagnosis mode, or Diagnosis-only mode, you must prepare a reorganization policy.

## What is a policy?

A *policy* is the expression, or definition, that is used by Policy Services to evaluate specific database states, such as the state of space utilization at a specific instance in time.

The policy definition specifies a database state to be evaluated, and specifies how Policy Services responds to any conditions that reach or exceed the threshold limits specified for this state. A condition is defined by a *rule* referred to in the policy.

Data collection is handled by DB Sensor, and the data storage is handled by the sensor data service component of Policy Services. The stored data, called *sensor data*, is managed by IMS Tools KB.

In the CRSS, reorganization policies are used to diagnose a database, to detect database exceptions, and to determine the recommended action for the Smart Reorg utility or IMS Online Reorganization Facility to take. These policies control the behavior of a Smart Reorg job or IMS Online Reorganization Facility job that runs in Conditional Reorganization mode, in Reorganization Diagnosis mode, or in Diagnosis-only mode. You can customize IBM-provided reorganization policies and a set of threshold values used in IBM-provided rules to detect specific database exceptions and to change the action that the Smart Reorg utility or IMS Online Reorganization Facility takes based on the database exceptions that are detected.

For more information about the policies, see the topic "Policy Services overview" in the *IMS Tools Base Policy Services User's Guide and Reference*.

## IBM-supplied policy and rule templates

Policy Services provides policy templates. Every policy belongs to a policy domain, and all policies and rules that are used by the Smart Reorg utility belong to the REORG policy domain, or the REORG domain for short.

You can use these policies and rules after you have completed the installation and configuration of Policy Services. You can use them without modification or you can customize them to suite your environment. You can also create new policies.

Policy Services provides the following basic policies:

- IBM.DBDDTYPE.HDAM for HDAM databases
- IBM.DBDDTYPE.PHDAM for PHDAM partitions
- IBM.DBDDTYPE.HIDAM for HIDAM databases
- IBM.DBDDTYPE.PHIDAM for PHIDAM databases
- IBM.DBDDTYPE.HISAM for HISAM databases
- IBM.DBDDTYPE.SHISAM for SHISAM databases
- IBM.DBDDTYPE.HDDB for IMS HD databases
- IBM.DBDDTYPE.FFDB for IMS full-function databases



All eight policies must be copied with the name of SYS.DBDBTYPE.*name*. By copying the policies with this naming convention, you can use the POLICYBY=DBTYPE control statement to reference the first six policies to enable automated policy selection by database type, and you can use the POLICYBY=NAME, POLICYNM=SYS.DBDBTYPE.*name* to reference the last two policies. If you use the SYS.DBDBTYPE.PHIDAM policy to evaluate a PHIDAM database, the primary index of the database is not evaluated. To evaluate the primary index, use the SYS.DBDBTYPE.PHIDAM.A policy by specifying the following statements and parameters:

- POLICYBY=NAME
- POLICYNM=SYS.DBDBTYPE.PHIDAM.A

For information about installing policies, see the topic "Installing initial domain policies and rules from IBM maintenance data set" in the *IMS Tools Base Configuration Guide*.

**Note:** To use the SYS.DBDBTYPE.PHIDAM.A policy, use the sensor data that was collected and stored by the jobs of IMS HP Pointer Checker, IMS HP Image Copy, or FF Stand-alone DB Sensor.

How to specify one of these policies or your own policy in a Smart Reorg utility job is described in "[Control statements for the Conditional Reorganization Support Service](#)" on page 162. For IMS Online Reorganization Facility, see the topic "HRFSYSIN DD statement keywords" in the *IMS Online Reorganization Facility User's Guide*.

Some templates for basic rules on the following categories of database statistics are provided and used in IBM-provided basic policies. You can also select one or more rule templates to create your own policies.

- Database record statistics
- Database segments statistics
- HDAM/PHDAM randomizing statistics
- Volume/Extent statistics
- Data set space usage statistics
- IMS space utilization statistics
- HISAM statistics
- Elapsed days since the last utility event

For the details about the IBM-supplied policies and rule templates, see the topic "Reference: Domain REORG" in the *IMS Tools Base Policy Services User's Guide and Reference*.

### **Related tasks**

#### Preparing a reorganization policy

Before you run a Smart Reorg utility job in Conditional Reorg mode, Reorganization Diagnosis mode, or Diagnosis-only mode, you must prepare a reorganization policy.

## **Sensor data and data elements**

Sensor data is the information collected by the DB Sensor component for the purpose of measuring the state of a specific database condition. The sensor data is handled by the IMS Tools KB server and stored in a central IMS Tools KB Sensor Data repository as records made up of data element values.

The data element values collected by DB Sensor are used for policy evaluation and are printed in Diagnosis reports. These data element values help you understand the condition of the database and, if necessary, how to address database exceptions.

For a list of data elements that DB Sensor can collect, see the topic "Data elements" in the *IMS Tools Base Policy Services User's Guide and Reference*. For the data elements that are used in IBM-supplied rules, see the topic "Domain REORG rules" in the *IMS Tools Base Policy Services User's Guide and Reference*.

Sensor data need not necessarily be collected by the DB Sensor component of the Smart Reorg utility. You can run IMS HP Pointer Checker, IMS HP Image Copy, or FF Stand-alone DB Sensor to collect and store sensor data. The latest sensor data that was collected by these jobs can be used by the CRSS in the following policy evaluation processes:

- The first evaluation phase in Conditional Reorganization mode and in Reorganization Diagnosis mode
- Diagnosis-only mode

For details, see [“DIAGDATAFROM control statement”](#) on page 164.

**Important:** When DB Sensor collects sensor data from an online database, the collected data element values might not reflect the latest database condition. For a list of data elements that have the potential of not storing the latest data, see [“Considerations for collecting sensor data from a database that is being updated”](#) on page 66.

#### **Related reference**

[BBERPRT data set: Diagnosis report](#)

The BBERPRT data set contains Diagnosis reports that are generated by conditional reorganization jobs.

## **Considerations for collecting sensor data from a database that is being updated**

In the first evaluation phase of a Smart Reorg job, DB Sensor can collect sensor data from an online database or from a database that is being updated by batch jobs.

However, when the database data set is VSAM, due to file system limitations, the following data element values reflect the database status of when the file was opened. Consequently, the values do not reflect the latest database status.

- DB\_RBA\_HIGH\_USED
- DB\_RBA\_HIGH\_ALLOC
- DB\_UNUSED\_BYTES
- DB\_PCT\_UNUSED\_BYTES
- DB\_PCT\_OF\_MAX\_DS\_SIZE
- DB\_PCT\_BYTES\_SEG (Note)
- DB\_PCT\_BYTES\_FREE\_SPACE (Note)
- DB\_NUM\_DBDS\_BLOCKS (Note)
- DB\_NUM\_CI\_SPLIT
- DB\_PCT\_NUM\_CI\_SPLIT
- DB\_NUM\_CA\_SPLIT
- DB\_PCT\_NUM\_CA\_SPLIT
- DBX\_NUM\_IPS
- DBX\_NUM\_IPS\_OVFL
- DBX\_PCT\_IPS\_OVFL
- DBX\_RBA\_HIGH\_USED
- DBX\_RBA\_HIGH\_ALLOC
- DBX\_UNUSED\_BYTES
- DBX\_PCT\_UNUSED\_BYTES
- DBX\_PCT\_OF\_MAX\_DS\_SIZE
- DBX\_NUM\_DBDS\_BLOCKS
- DBX\_NUM\_CI\_SPLIT
- DBX\_PCT\_NUM\_CI\_SPLIT
- DBX\_NUM\_CA\_SPLIT
- DBX\_PCT\_NUM\_CA\_SPLIT

**Note:** For DB\_PCT\_BYTES\_SEG, DB\_PCT\_BYTES\_FREE\_SPACE, and DB\_NUM\_DBDS\_BLOCKS, if the database data set is a VSAM KSDS (that is, HISAM or SHISAM), data element values do not reflect the

latest status. For VSAM ESDS (that is, HDAM, HIDAM, PHDAM, or PHIDAM), these data element values always reflect the latest status.

To obtain the latest values, consider running the Smart Reorg job as follows:

- For a database that is being updated by batch jobs, run the Smart Reorg job after the batch jobs are complete.
- For an online database, specify the TOSIXCFGRP control statement so that DB Sensor uses IMS Tools Online System Interface to collect the latest VSAM statistics and sets the data element values based on the collected statistics.

**Restriction:** For VSAM data sets that use SHAREOPTION(1,3), the file system does not permit DB Sensor to collect sensor data while the database is being updated.



---

## Chapter 6. Parallel Reorganization Service

The Parallel Reorganization Service is the database reorganization service provided by the Reorganization Manager of the Smart Reorg utility. This service enables you to reorganize HISAM, SHISAM, HDAM, HIDAM, PHDAM, or PHIDAM database in a single job step.

### Topics:

- [“What is Parallel Reorganization Service?” on page 69](#)
- [“Data and process flow of Parallel Reorganization Service” on page 75](#)

---

### What is Parallel Reorganization Service?

The Parallel Reorganization Service controls the entire reorganization process including the Unload task, the Reload task, and any other reorganization-related optional tasks that are specified in the Smart Reorg JCL.

The Parallel Reorganization Service uses different data sets for the input database and the output reorganized database (called the shadow database) and passes unloaded records from the Unload task to the Reload task directly. This approach reduces the number of I/Os because the need for an unload file is eliminated. If IMS Index Builder is installed, you can also reorganize the secondary indexes of PHDAM, PHIDAM, HISAM, HDAM, or HIDAM database. When the index building task is called, the Parallel Reorganization Service passes the secondary index information to the Index Builder task for processing. Secondary indexes for the reorganized database, if they are defined, can be built by the IMS Index Builder task while the database is being reorganized.

If the non-HALDB to be reorganized has no logical relationship, the reorganized database and the rebuilt indexes can be image-copied while they are reloaded to the shadow database or rebuilt to the shadow indexes. The blocks that are built by the Reload task and the index records that are built by the IMS Index Builder task are passed to the image copy routines directly without using any work data sets, which also reduces the number of I/Os. The blocks and index records that are passed to image copy routines can be checked by the HASH check function of IMS HP Pointer Checker, if it is installed, while the blocks and index records are image-copied.

If the database is a non-HALDB and has logical relationships, the image copy task cannot be run concurrently. However, if the database is an HDAM or a HIDAM and the logical relationships of each database is only internal, IMS HP Prefix Resolution can be run as a subtask in the Smart Reorg utility job step to resolve logical relationships.

The reorganization speed is increased because these tasks run concurrently and the intermediate data is passed between these tasks without physical I/Os.

You can keep the database online and allow read access to users during the reorganization because the Parallel Reorganization Service reorganizes the database into a shadow database. The Parallel Reorganization Service renames the shadow data sets with the original data set names after a successful reorganization. This feature is called *data set name swapping* or *name swapping*. The database and its indexes need to be offline only long enough to swap the data set names.

The reorganization process, including the name swapping process, can be automated so that no manual intervention is required. The IMS /DBD command or the DBRC CHANGE.DB READON command to place the database in read-only mode can be issued automatically by IMS Database Reorganization Expert before the reorganization starts. The IMS /DBR command or the DBRC CHANGE.DB NOAUTH command is issued automatically to prevent authorization to the database before the data set names of input and output databases are swapped. Once the reorganization of the database completes and the data set name swapping succeeds, the DBRC NOTIFY.REORG command is issued to create a REORG record. If the image copy is taken by the image copy task, the DBRC NOTIFY.IC command can also be issued to register the image copy data set. If the database has no logical relationship, the name swapping process can be automated for HISAM, HDAM, and HIDAM. The name swapping process can be automated for a HALDB, even if the database has logical relationships.

The Parallel Reorganization Service uses the following subcomponents:

- Reorganization Manager, which manages the reorganization scenario
- Various subtasks, each of which performs a specific reorganization function
- A data transfer service, called IMS Parallel Reorganization Pipe (IPRPIPE), between subtasks

The following figure shows the system flow of the Parallel Reorganization Service for a database that has secondary indexes and that has no logical relationship.

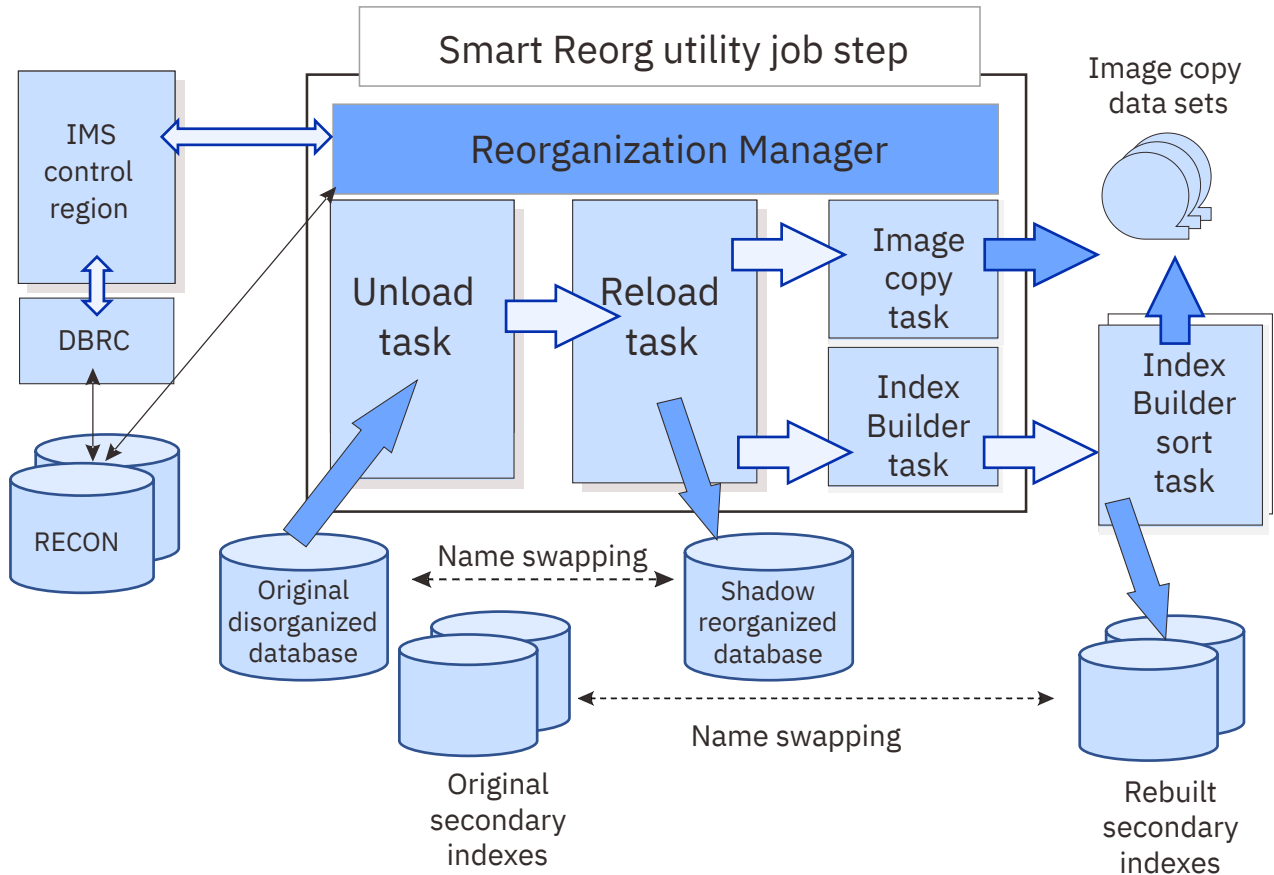

Figure 4. System flow of Parallel Reorganization Service

The Parallel Reorganization Service provides the following features:

**Provide recoverability of the reorganization process**

You can restart the reorganization process whenever you encounter a failure because parallel reorganization preserves your original databases. The original database exists throughout the reorganization process.

**Allow read access to the database during reorganization**

Because the original database exists throughout the reorganization process, you can allow applications to have read access to the database during most of the reorganization process. The Parallel Reorganization Service enables *read* access to the database during the unload, reload, and index building processes. The access to the database is restricted only during the post-reorganization processing.

**Provide full capability of stand-alone IPR Unload utility and IPR Reload utility, and IMS Index Builder**

You can use, for example, the following features of these utilities:

- High-performance processing with optimized buffer specification

- User exits for IPR Unload utility and IPR Reload utility

### **Provide full capability of stand-alone IMS HP Image Copy**

You can specify options for IMS HP Image Copy in the ICEIN data set in almost the same format as that for the stand-alone IMS HP Image Copy.

### **Provide capability for pointer checking while the database is being image-copied**

You can activate the HASH pointer check function while the blocks or index records of the reorganized data sets are being image-copied.

### **Provide capability for resolving internal logical relationship in a single job step**

Prefix resolution and update for the internal logical relationship can be done in the Parallel Reorganization Service job step. You can also run IMS HP Image Copy in the same job step for such a database after logical relationships are resolved.

### **Allocate input and output database data sets dynamically**

Both the original and the shadow database data sets are allocated dynamically. You do not need to code DD statements for these data sets. DASD space for the shadow database data sets can be allocated automatically.

### **Swap data set names automatically**

At the end of the reorganization process, data set names can be swapped automatically. Reorganization Manager prohibits authorization during the swap process. If you enable automatic data set name swapping, DBRC must be active.

### **Notify DBRC of the completion of reorganization automatically**

The DBRC NOTIFY.REORG command is issued automatically after data set name swapping ends successfully.

### **Restart databases automatically**

The IMS /STA command is issued automatically to the IMS online subsystems, which accepts /DBR.

### **Change DBDs (Unconditional Reorganization mode)**

You can change some of the database definition parameters during the reorganization when the job is run in Unconditional Reorganization mode.

### **Notes:**

- For PHDAM and PHIDAM, the partitions that are defined in RECON as online reorganization capable (OLRCAP) are also supported.
- Prefix Resolution task can be activated only for HDAM and HIDAM databases that have only internal logical relationships.

In summary, the Parallel Reorganization Service offers you the following benefits:

### **Simplify the reorganization process**

The reorganization job can be made simpler and easier because all utilities that are necessary for the database reorganization can be run in a single job step.

### **Reduce time for database reorganization**

The Parallel Reorganization Service reduces the elapsed time of the reorganization by:

- Enabling Unload, Reload, Index Builder, and Image Copy tasks to run concurrently.
- Eliminating I/Os for intermediate data sets by the following methods:
  - The unload data set is not created, which reduces EXCPs, and no tape drive or DASD workspace is needed to store the data set.
  - Index maintenance records are not written to the DFSURWF1 data set. In this way, the space and the EXCPs for the data set are reduced or eliminated.
  - Database blocks and index records that are created by the Reload task are passed directly to the Image Copy task. This approach eliminates the need to scan database data sets after a reorganization to take the image copies.

## Reorganization tasks and IPRPIPE

The Parallel Reorganization Service invokes subtasks to reorganize the database and to build secondary indexes.

The reorganization subtasks that are invoked are:

- *Unload task* provided by IMS HP Unload
- *Reload task* provided by IMS HP Load
- *Index Builder task* provided by IMS Index Builder (optional)

These tasks are called *reorganization tasks*.

IPRPIPE provides a high performance data transfer service between reorganization tasks. The Parallel Reorganization Service uses this service between the Unload task and the Reload task for transferring HD unloaded data, and between the Reload task and the Index Builder task for transferring DFSURWF1 or HPSRWFP data. By using IPRPIPE, these three tasks can run concurrently without the use of intermediate data sets.

IPRPIPE eliminates the need for unload data sets by passing records from Unload tasks directly to Reload tasks through a *pipe* allocated by the IPRPIPE service. If the database has secondary index records and the index building option is selected, the DFSURWF1 or HPSRWFP records created by the Reload tasks are transferred to the Index Builder tasks through another *pipe* to rebuild secondary indexes for the reorganized database. This method eliminates the DFSURWF1 data set or the HPSRWFP data set unless there are logical relationships to be resolved.

## Reorganization Manager

This topic describes the major functions that Reorganization Manager provides.

Reorganization Manager provides Smart Reorg with full DBRC support. For more information, see [“Setting up the DBRC command authorization”](#) on page 47.

Subsections:

- [“Dynamic allocation of database data sets”](#) on page 72
- [“Allowing DBD change during reorganization \(In Unconditional Reorganization mode\)”](#) on page 72
- [“Automated IMS command processing”](#) on page 73
- [“Automated DBRC authorization and unauthorization processing”](#) on page 73
- [“Automated data set name swapping”](#) on page 73
- [“Automated DBRC notification processing”](#) on page 74
- [“Automated DBRC processing for restoring authorization flags”](#) on page 74

### Dynamic allocation of database data sets

By default, Reorganization Manager dynamically allocates input database data sets by using DFSMDA members or DBRC registrations. For output shadow database data sets, Reorganization Manager creates the names based on the corresponding original data set names and allocates them dynamically. To disable the function, you can specify the DYNALLOC control statement.

If the SPACEALLOC option is specified, the DASD space for the shadow database is allocated automatically. By default, you need to preallocate the DASD space in the prior IDCAMS step.

For details, see [“Considerations for database data sets”](#) on page 104, [“DYNALLOC control statement”](#) on page 136, and [“SPACEALLOC control statement”](#) on page 156.

### Allowing DBD change during reorganization (In Unconditional Reorganization mode)

Some DBD parameters can be changed during the reorganization when the job is run in Unconditional Reorganization mode. For details, see [“NEWDBD control statement”](#) on page 149.



## Automated IMS command processing

If you specify IMSCMD=YES, Reorganization Manager does the following automatically:

- At the beginning of the reorganization, Reorganization Manager issues either a /DBD command or a /DBR command depending on the DBSHARE option. The /DBD command places the database in read-only mode for the online system and the /DBR command places the database in the STOPPED, NOT OPEN status. Further authorization for the database is prohibited.
- During the post-reorganization processing that includes data set name swapping, Reorganization Manager automatically issues a /DBR command.
- After the post-reorganization processing, Reorganization Manager automatically issues a /STA command to the subsystems that accepted the /DBR command. You must specify both IMSCMD=YES,TOSI and STARTDB=YES.

These commands are issued through the E-MCS console or the IMS Tools Online System Interface for an online IMS subsystem. See [“IMSCMD control statement”](#) on page 140 and [“DBSHARE control statement”](#) on page 132. For details of how to set up E-MCS console or IMS Tools Online System Interface for the Smart Reorg utility, see [“Setting up for using E-MCS console for IMS command processing”](#) on page 50.

If you specify AUTHFAIL=WTOR, WTOR messages are issued when the preceding commands are necessary to be issued and Reorganization Manager waits for operator responses. For details, see [“AUTHFAIL control statement”](#) on page 128.

## Automated DBRC authorization and unauthorization processing

If you specify DBRCAUTHCMD=YES, Reorganization Manager does the following automatically:

- At the beginning of the reorganization, Reorganization Manager issues either a CHANGE.DB READON command or a CHANGE.DB NOAUTH command depending on the DBSHARE option. The CHANGE.DB READON command changes the READ ONLY flag of the database in RECON, and the CHANGE.DB NOAUTH command changes the PROHIBIT AUTHORIZATION flag of the database in RECON. Further authorization for the database is prohibited.
- During data set name swapping, Reorganization Manager automatically issues a CHANGE.DB NOAUTH command.
- After the post-reorganization processing ends successfully, Reorganization Manager automatically issues the CHANGE.DB AUTH READOFF command unless LASTAUTHFLAG=ORIGINAL is specified. If you specify LASTAUTHFLAG=ORIGINAL, Reorganization Manager automatically issues the CHANGE.DB command to restore the authorization flags in RECON to the original state. For details, see [“LASTAUTHFLAG control statement”](#) on page 146.
- Before the Smart Reorg job terminates abnormally due to an error, Reorganization Manager automatically issues the CHANGE.DB command to restore the authorization flags in RECON to the original state. For details, see [“Automated DBRC processing for restoring authorization flags”](#) on page 74.

See [“DBRCAUTHCMD control statement”](#) on page 131 and [“DBSHARE control statement”](#) on page 132.

If you specify AUTHFAIL=WTOR, WTOR messages are issued when the previously described commands must be issued manually and Reorganization Manager waits for operator responses. For details, see [“AUTHFAIL control statement”](#) on page 128.

**Note:** If the Smart Reorg utility issues the DBRC commands successfully but the database is used by another IMS system, the necessary authorization condition might not be satisfied. If you run a Smart Reorg job while the database is online, it is recommended that you specify IMSCMD=YES rather than DBRCAUTHCMD=YES.

## Automated data set name swapping

When the reorganization is completed, the data set names of the old and new data sets must be swapped so that the reorganized data sets of the database or of the HALDB partition can be made available.

Reorganization Manager invokes IDCAMS to swap the names. The names of the original (disorganized) database data sets and the shadow (reorganized) data sets are swapped automatically.

You can keep the database online and allow read access to users while the parallel reorganization job is running. The database or the HALDB partition needs to be offline only long enough to swap data set names.

If the reorganization ends before the data set names are swapped, you can abandon the reorganization. This method eliminates the need to take an image copy of the disorganized database before the reorganization and the need for recovery if the reorganization fails.

For details of name swapping, see [“Considerations for database data sets” on page 104](#) and [“NAMESWAP control statement” on page 147](#).

## Automated DBRC notification processing

If the data set name swapping succeeds, Reorganization Manager issues the DBRC NOTIFY.REORG command for the database or the HALDB partitions to create REORG records. If you request that the secondary index be built during parallel reorganization, the NOTIFY.REORG command is also issued against the secondary indexes.

Reorganization Manager can also issue the DBRC NOTIFY.IC or NOTIFY.UIC commands for the database, HALDB partitions, and indexes. For details, see [“Image Copy and DBRC” on page 112](#) and [“NAMESWAP control statement” on page 147](#). See also [“ICNEEDED control statement” on page 138](#).

## Automated DBRC processing for restoring authorization flags

When one or more errors are detected in the main task or subtasks, the Smart Reorg utility issues the CHANGE.DB command to restore the READ ONLY flag or the PROHIBIT AUTHORIZATION flag in RECON before ending the reorganization processing abnormally.

The Smart Reorg utility issues the CHANGE.DB command when all the following conditions are met:

- IMSCMD=YES or DBRCAUTHCMD=YES is specified.
- The Smart Reorg utility issues the IMS command or the DBRC command at the beginning of the reorganization.
- The Smart Reorg utility detects one or more errors in the main task or subtasks before the completion of data set name swapping. Specify NAMESWAPFAIL=BACKOUT so that DBRC flags are automatically restored at times of error.

## Prefix Resolution and update processing during reorganization

If an HDAM or a HIDAM database has internal logical relationships, the Parallel Reorganization Service can invoke IMS HP Prefix Resolution as a subtask to update the segment prefix before data set name swapping is done.

For details, see [“Considerations for logical relationships” on page 109](#).

## Image Copy processing and HASH pointer checking

The Parallel Reorganization Service supports Image Copy processing and HASH pointer checking in the Smart Reorg utility job step.

You do not need to add a separate job step for post-reorganization image copy processing. The Image Copy function is provided by IMS HP Image Copy, and the HASH pointer checking function is provided by IMS HP Pointer Checker.

The Parallel Reorganization Service supports the following two types of Image Copy processing:

- Type-A: Image copy during the reorganization phase
- Type-B: Image copy after the reorganization phase

Here, the reorganization phase means the phase of the Parallel Reorganization Service process in which the database is unloaded, reloaded, and the secondary indexes are built. The flows of Image Copy processing are shown in [“Data and process flow of Type-A Image Copy”](#) on page 79 and [“Data and process flow of Type-B Image Copy with Prefix Resolution/Update”](#) on page 80.

If the prefix resolution and update processing for internal logical relationships are necessary, only Type-B Image Copy can be used.

For details about Type-A and Type-B Image Copy processing, see [“Considerations for Image Copy processing”](#) on page 110. For details about DBRC notification processing, see [“Image Copy and DBRC”](#) on page 112.

Restrictions on Image Copy processing are described in [“Smart Reorg restrictions and requirements”](#) on page 58.

### **Related concepts**

[Data and process flow of Parallel Reorganization Service](#)

This topic describes the data and process flow for the Parallel Reorganization Service.

## **Data and process flow of Parallel Reorganization Service**

---

This topic describes the data and process flow for the Parallel Reorganization Service.

Subsections:

- [“Data and process flow of the Parallel Reorganization Service”](#) on page 75
- [“Data and process flow of Type-A Image Copy”](#) on page 79
- [“Data and process flow of Type-B Image Copy with Prefix Resolution/Update”](#) on page 80
- [“Data and process flow of reloading database and taking image copy”](#) on page 81
- [“Data and process flow of conditional reorganization and image copy for HALDB”](#) on page 82

### **Data and process flow of the Parallel Reorganization Service**

The following figure shows the general data flow of the Parallel Reorganization Service for an HDAM that has a secondary index. The general data flow for HIDAM is similar to this flow except that the primary index is reorganized into a shadow primary index.

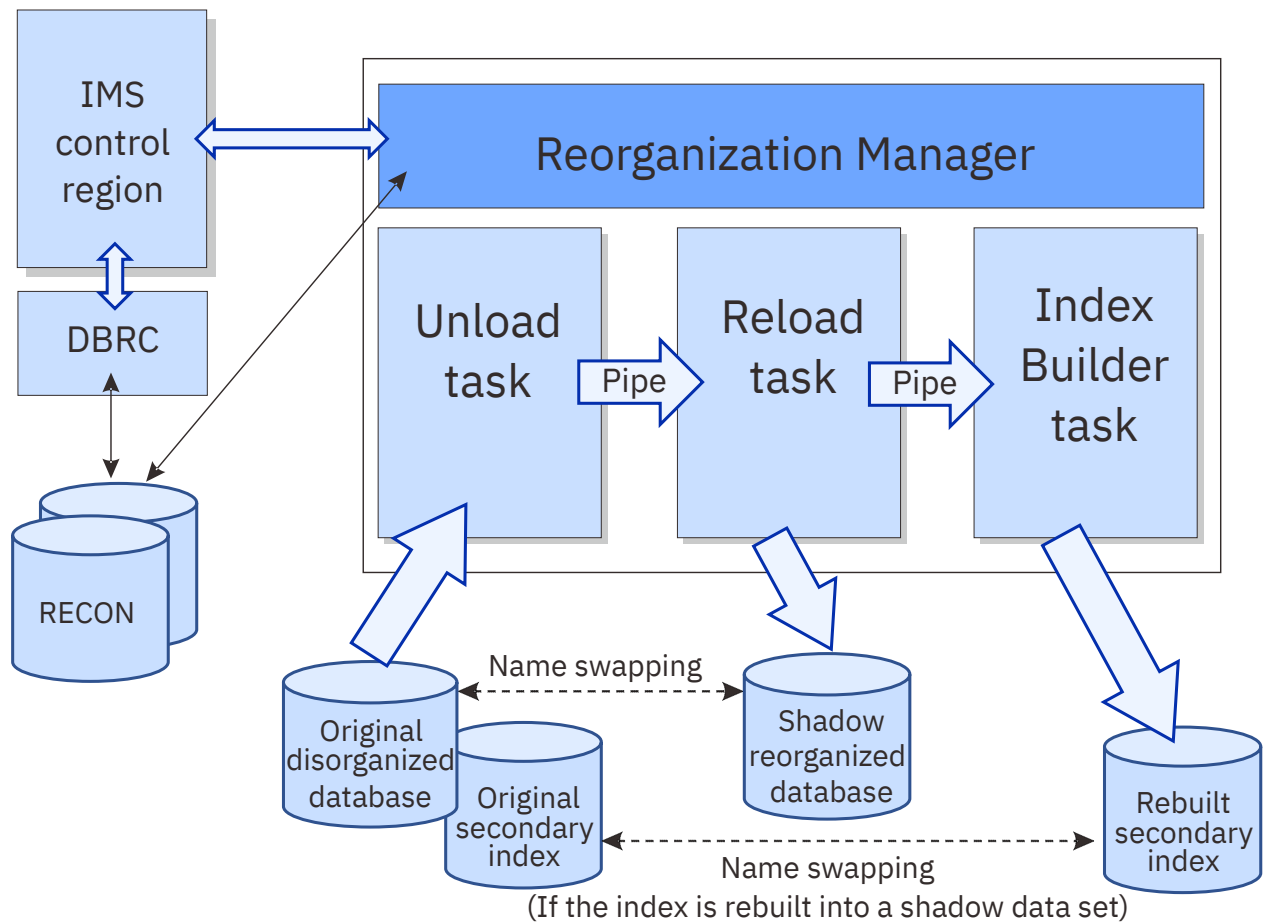

Figure 5. System flow of the Parallel Reorganization Service for HDAM with secondary index

The following figure shows the general data flow for the parallel reorganization of a partition of PHDAM that has a PSINDEX. In this example, it is assumed that only partition PART1 is reorganized. Note that the indirect list data set (ILDS) for the partition is built to the shadow ILDS by the Reload task. The general data flow for the parallel reorganization of a PHIDAM partition is similar to this flow except that the primary index for the selected partition is reorganized into a shadow primary index. In this figure, it is assumed that the partition to be reorganized is either not capable of online reorganization or capable of online reorganization and the A-through-J and X data sets are active.

In the following figure:

1. Labels PART1A, PART2A, PART3A, and PART4A are the DD names of active data sets for each partition.
2. Labels PART1L, PART2L, PART3L, and PART4L are the ILDSs for the partitions.
3. Label PART1M is the DD name for the shadow database data set, and PART1Z for the shadow ILDS.
4. The data set names for the original data sets and the shadow data sets of partition PART1 that is to be reorganized.

You can also reorganize all partitions or selected multiple consecutive partitions of a HALDB by using the Parallel Reorganization Service.

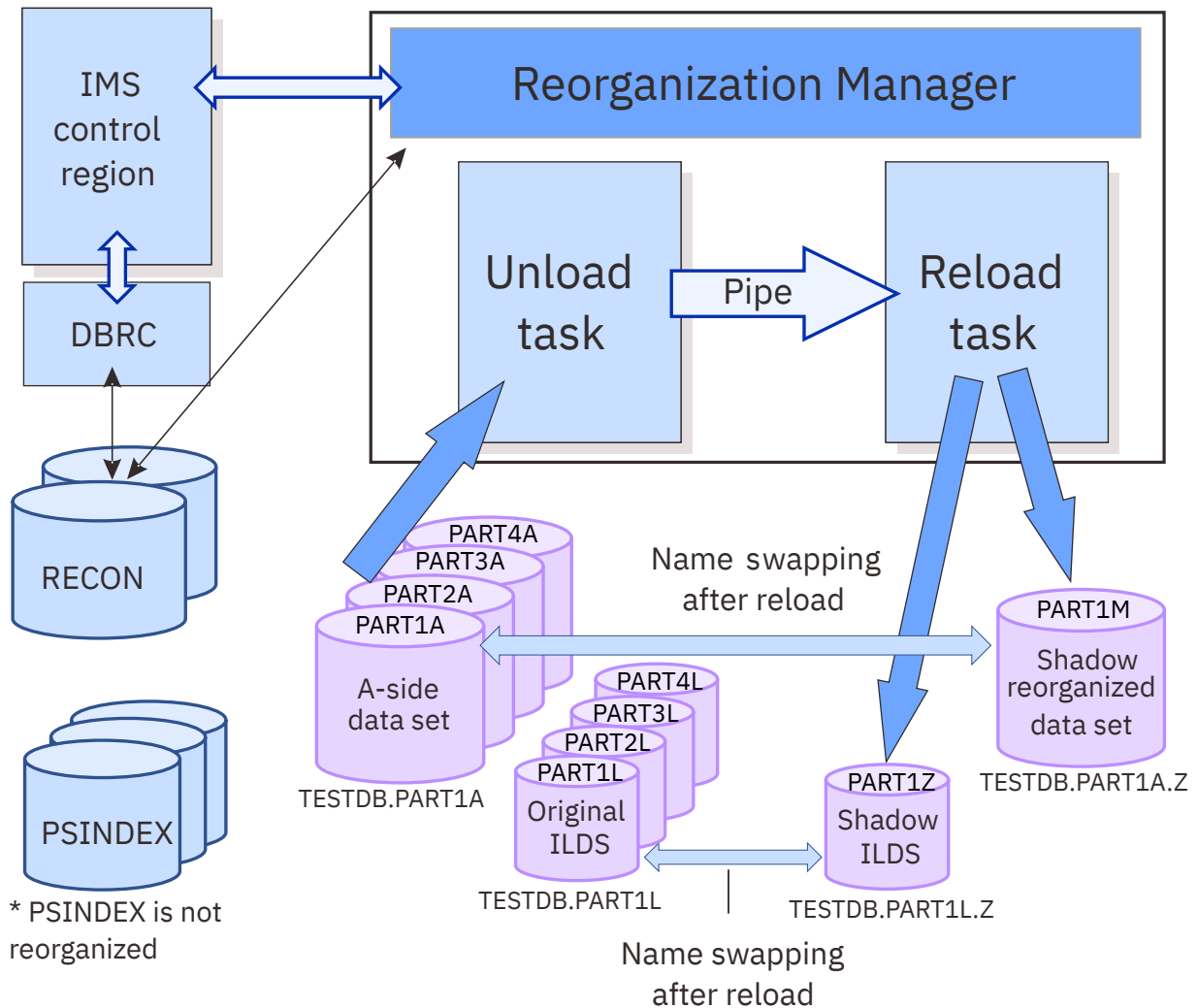

Figure 6. System flow of the Parallel Reorganization Service for PHDAM with PSINDEX (1)

Figure 7 on page 78 and Figure 8 on page 79 show the general data flow for the parallel reorganization of PHDAM that has a PSINDEX. It is assumed that the partition to be reorganized is PART1, which is online reorganization capable and M-through-V and Y data sets are active. When a HALDB partition that is online reorganization capable is reorganized, shadow data set names are always swapped with data set names A-through-J and Y by data set name swapping. If there are no A-through-J and X data sets, the reorganized shadow data sets are renamed to the A-side data set names as shown in Figure 7 on page 78. If A-side data sets exist, the shadow data sets are swapped with the A-side data sets as shown in Figure 8 on page 79.

For details about the name swapping process, see “NAMESWAP control statement” on page 147. For details about the DD names and the data set names of original and shadow data sets, see “Considerations for database data sets” on page 104.

Figure 7 on page 78 and Figure 8 on page 79 show the following:

1. PART1M, PART2A, PART3M, and PART4A are the DD names of active data sets of each partition.
2. PART1L, PART2L, PART3L, and PART4L are the ILDSs for the partitions.
3. PART1A is the DD name for the shadow data set of partition PART1 that is to be reorganized.
4. The data set names of the original data sets and the shadow data sets of partition PART1 are shown below the databases that are shaded.

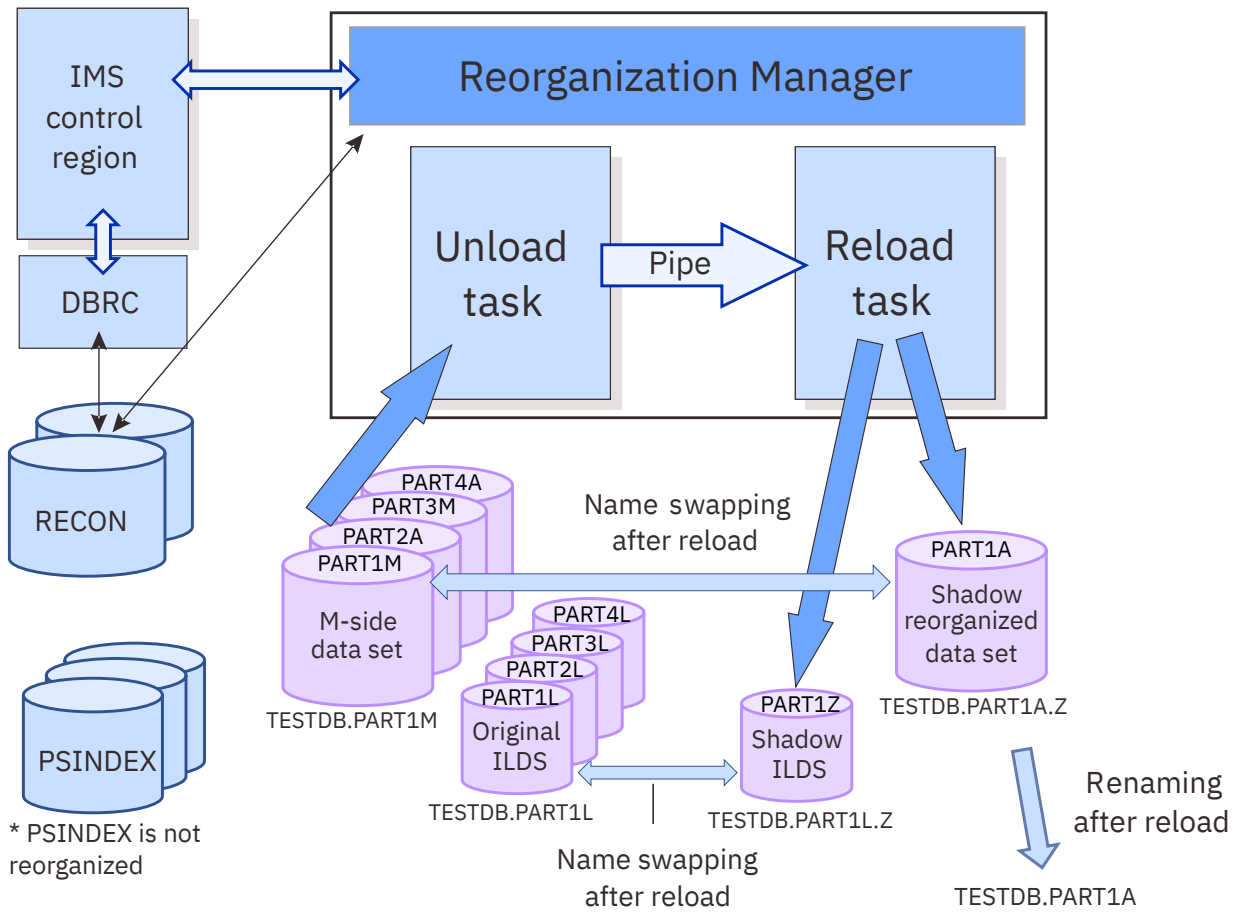

Figure 7. System flow of the Parallel Reorganization Service for PHDAM with PSINDEX (2)

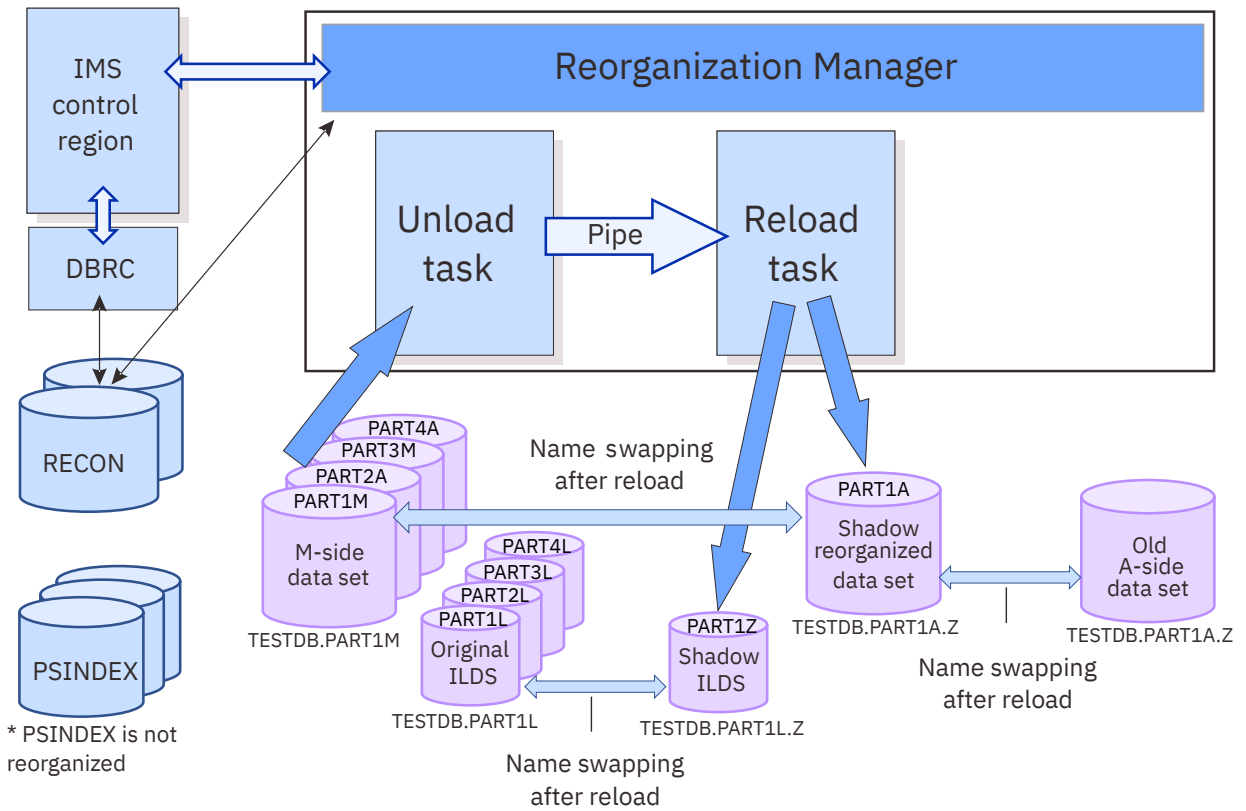

Figure 8. System flow of the Parallel Reorganization Service for PHDAM with PSINDEX (3)

### Data and process flow of Type-A Image Copy

The following figure shows the data flow and process flow of Type-A Image Copy.

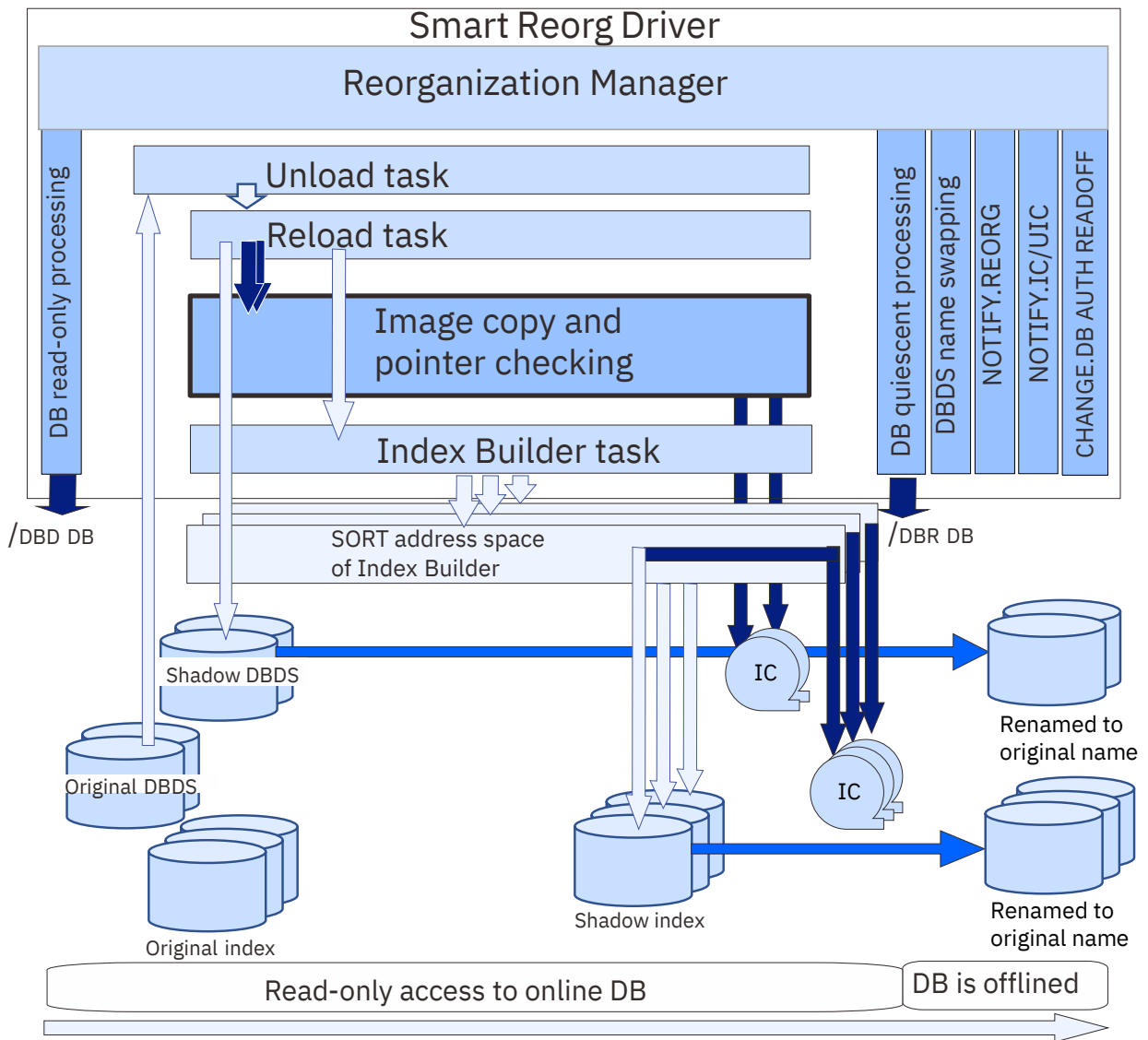

Figure 9. Data and process flow of Type-A Image Copy

If INDEXBLD=YES is specified for HDAM, HIDAM, or HISAM that has a secondary index or indexes, the image copy of each secondary index is taken in a SORT address space of Index Builder. The image copy data set for the secondary index is always allocated dynamically in the SORT address space.

**Restriction:** Type-A Image Copy cannot be used when PSINDEXes are built with the PSINDEXBLD=YES option. Use Type-B Image Copy when building PSINDEXes.

### Data and process flow of Type-B Image Copy with Prefix Resolution/Update

The following figure shows the data flow and process flow of Type-B Image Copy with Prefix Resolution and Update.



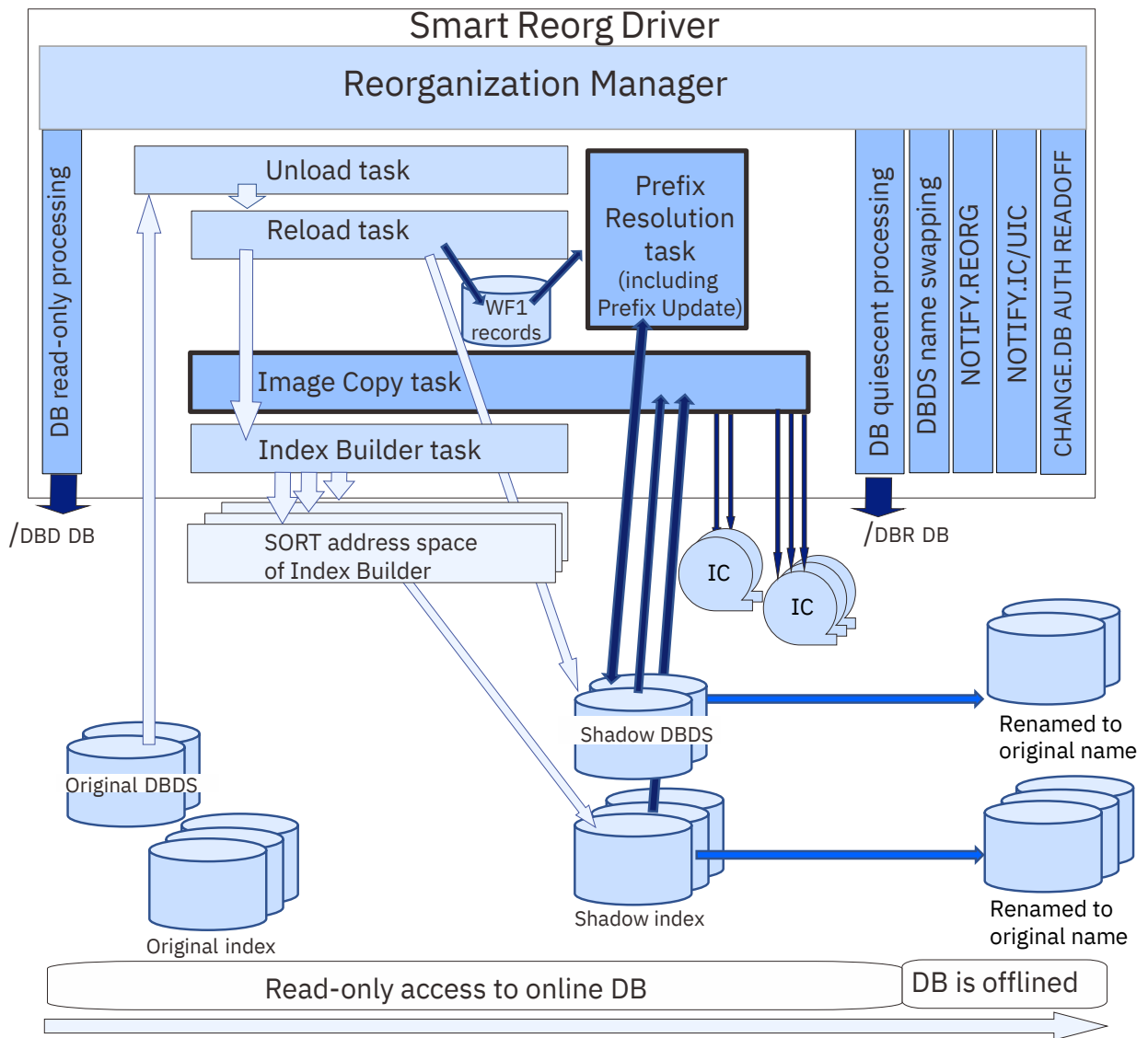

Figure 10. Data and process flow of Type-B Image Copy with Prefix Resolution/Update

### Data and process flow of reloading database and taking image copy

The following figure shows the general data flow of the Parallel Reorganization Service for an HDAM that has a secondary index when REORGINPUT=ULDS is specified. In this case, the Reload task directly reloads the unload data set to the original database data set, and shadow database data sets are not used. In the following figure, Type-A Image Copy is used, but Type-B Image Copy also supports this scenario.

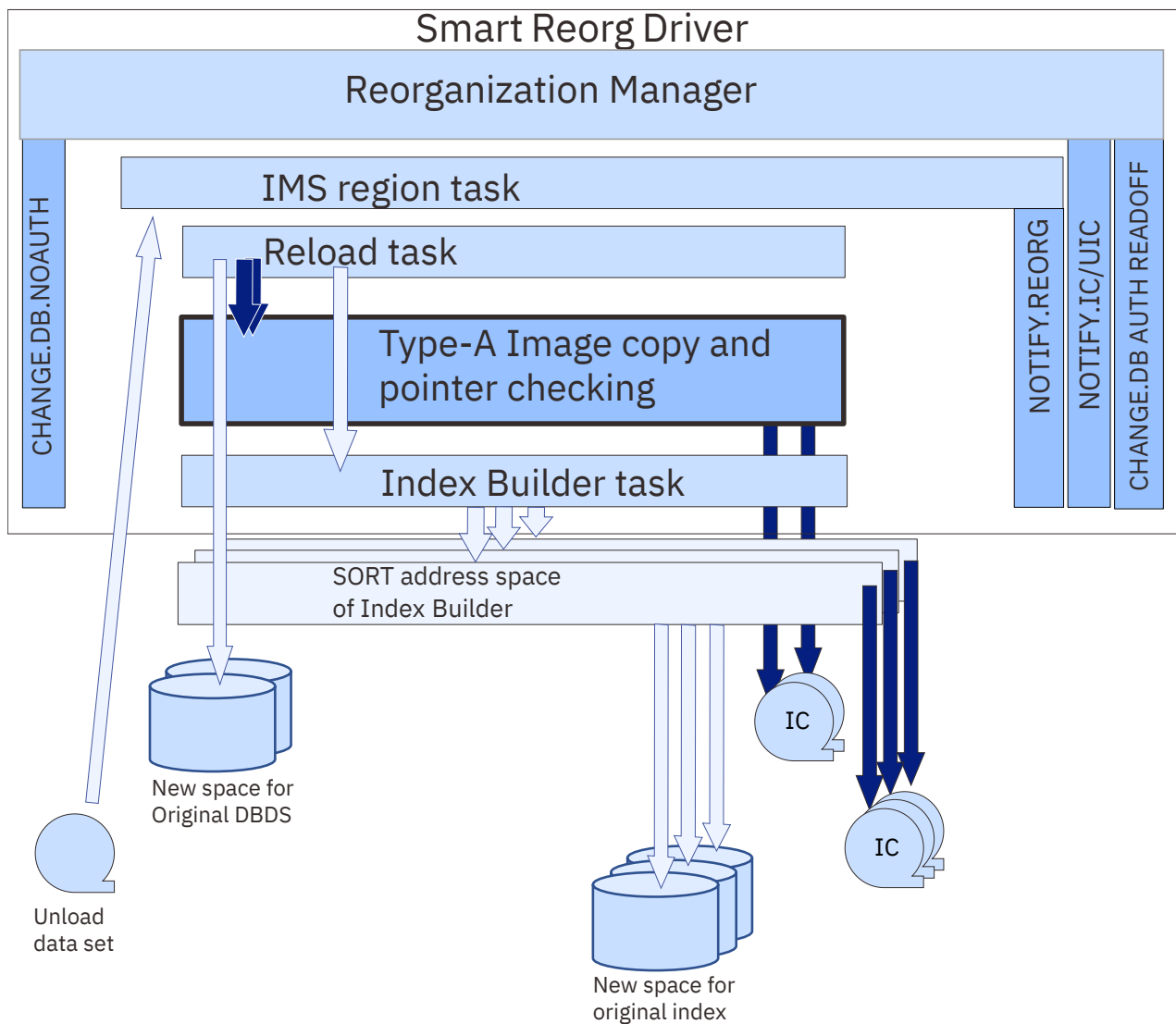

Figure 11. Data and process flow of reloading a database and taking an image copy

### Data and process flow of conditional reorganization and image copy for HALDB

When CRIC=ALWAYS is specified, the Smart Reorg utility creates image copies of all database data sets or all HALDB partitions regardless of whether the database or all partitions are reorganized. The type of Image Copy processing that is applied to each HALDB partition depends on whether the partition is reorganized or not.

If the entire HALDB is the target of reorganization or if all the HALDB partitions that are specified on the PARTITION control statement are the target of reorganization, the type of Image Copy processing depends on the value specified on the ICTYPE control statement. Otherwise, image copies of partitions are created with Type-B Image Copy processing as follows:

- For partitions that are reorganized, image copies are created from shadow database data sets.
- For partitions that are not reorganized, image copies are created from original database data sets.

The following figure shows the data flow when only some of the partitions are the target of reorganization.

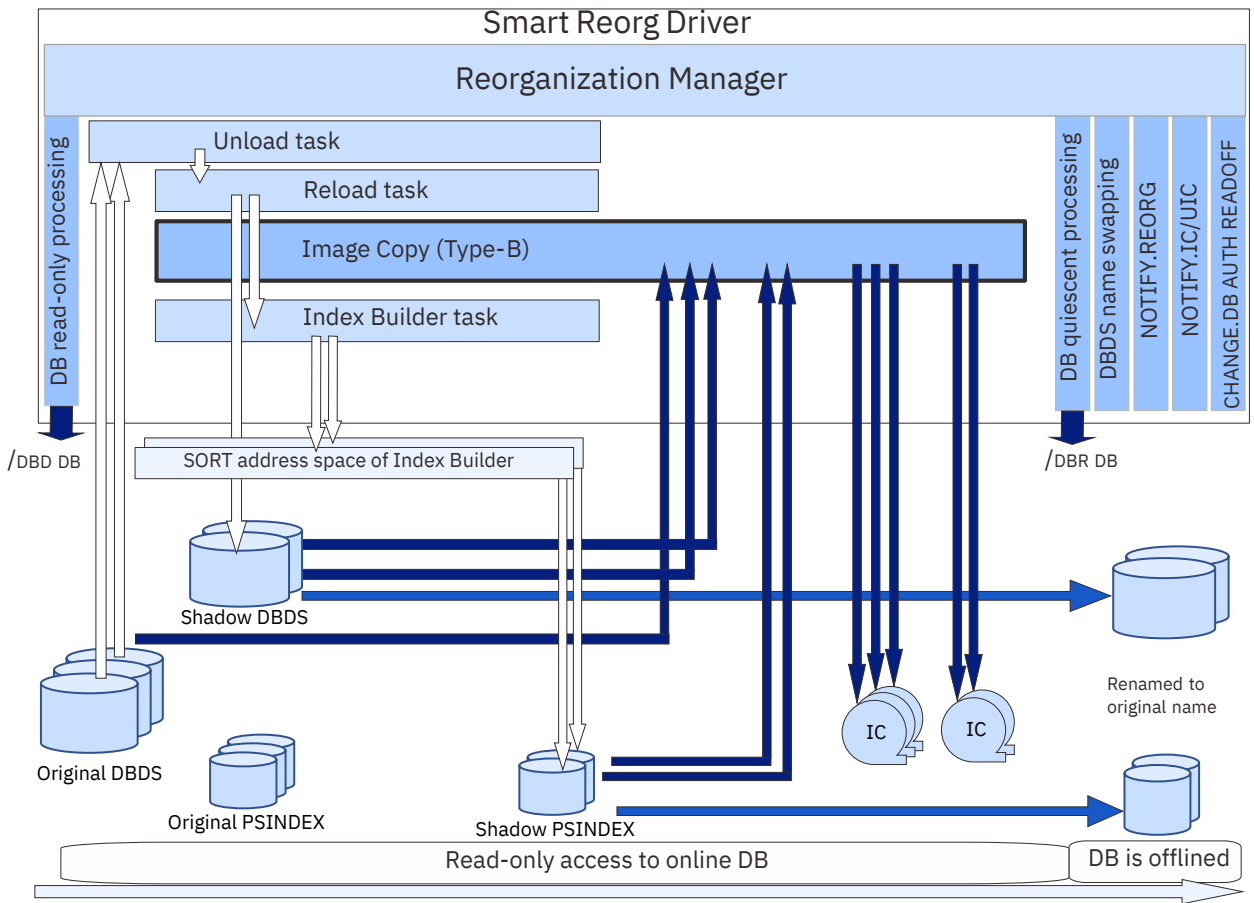

Figure 12. Data and process flow of conditional reorganization and image copy (Type-B Image Copy)



---

## Chapter 7. Using the Smart Reorg utility

You can run the Smart Reorg utility in four different runtime modes; Conditional Reorganization mode, Unconditional Reorganization mode, Reorganization Diagnosis mode, and Diagnosis-only mode.

Use Conditional Reorganization mode when you do not know the database status and you want to reorganize the database only if database reorganization is needed. If you already know the status of the database or when you want to reorganize the database regardless of its status, use Unconditional Reorganization mode. If you want to reorganize the database regardless of its status and if you want to know the database status before and after the reorganization, use Reorganization Diagnosis mode. If you do not want to reorganize the database, but want to check the database status, use Diagnosis-only mode.

Regardless of the mode you select, you must prepare and submit a Smart Reorg JCL stream to run the Smart Reorg utility. The following topics describe required steps for each runtime mode.

### Topics:

- [“Running a job in Unconditional Reorganization mode” on page 85](#)
- [“Running a job in Conditional Reorganization mode” on page 86](#)
- [“Running a job in Reorganization Diagnosis mode” on page 87](#)
- [“Running a job in Diagnosis-only mode” on page 88](#)

---

## Running a job in Unconditional Reorganization mode

You can run a Smart Reorg job in Unconditional Reorganization mode to reorganize the database regardless of the database status.

### Procedure

To run a Smart Reorg job in Unconditional Reorganization mode, complete the following steps:

1. Determine a schedule to run a reorganization job for the target database.
2. Code and submit JCL.
  - a) Code the JCL stream for the Smart Reorg job.

If SPACEALLOC=YES is not specified, the JCL stream must include an IDCAMS step before the Smart Reorg job step. The IDCAMS step allocates DASD space for each output (shadow) data set.

For more information, see [Chapter 8, “Smart Reorg JCL requirements,” on page 89](#).
  - b) Specify the control statements in the HPSIN DD statement.

To run the job in Unconditional Reorganization mode, specify CONDREORG=NO in the (REORG) block.

Specify other control statements. See [Chapter 9, “Smart Reorg control statements,” on page 117](#) for more information.

**Tip:** For information about control statements that can automate and reduce some of your manual operations, see [“Hints and tips for specifying control statements” on page 178](#).
  - c) Submit the Smart Reorg JCL stream for the database.
3. Check the results of the job by reviewing the reports that are produced by individual reorganization tasks, which include the Unload task and the Reload task.

## Running a job in Conditional Reorganization mode

---

You can run a Smart Reorg job in Conditional Reorganization mode to reorganize the database based on the status of the database.

### Procedure

To run a Smart Reorg job in Conditional Reorganization mode, complete the following steps:

1. Prepare a reorganization policy for evaluating the database statistics.

For instructions for preparing a reorganization policy, see [“Preparing a reorganization policy”](#) on page 205.

2. Code and submit JCL.

- a) Code the JCL stream for the Smart Reorg job.

If SPACEALLOC=YES is not specified, the JCL stream must include an IDCAMS step before the Smart Reorg job step. The IDCAMS step allocates a DASD space for each output (shadow) data set.

For more information, see [Chapter 8, “Smart Reorg JCL requirements,”](#) on page 89.

- b) Specify the control statements in the HPSIN DD statement.

To run the job in Conditional Reorganization mode to conditionally reorganize the database based on the database status, specify CONDREORG=YES in the (REORG) block.

By default, the database statistics that reflect the state of database at the time when the Smart Reorg job started are collected dynamically. If you want to use the most recent database statistics that are already stored in the Sensor Data repository, specify DIAGDATAFROM=REPOSITORY in the (CONDREORG) block.

If you want to change the return code of the Smart Reorg job step that will be issued when a critical-level exception remains, specify the RC\_CHANGE control statement in the (REORG) block.

Specify other control statements. See [Chapter 9, “Smart Reorg control statements,”](#) on page 117 for more information.

**Tip:** For information about control statements that can automate and reduce some of your manual operations, see [“Hints and tips for specifying control statements”](#) on page 178.

- c) Submit the Smart Reorg JCL stream for the database.

3. Check the results of the job and determine if database exceptions exist in the database.

If you receive no exception notification messages, no further actions are required.

If you receive one or more exception messages, follow these steps:

- a) Check the outputs from the Smart Reorg utility.

- If you have customized the reorganization policy to send exception notification messages by using the z/OS WTO service or the TSO/E SEND command, check those messages that are issued by the Smart Reorg utility. Those messages include a job summary message (policy evaluation summary message) that summarizes the result of policy evaluation that was performed by Policy Services during the job. To check the policy evaluation summary message, see [“Checking the policy evaluation summary message”](#) on page 205.
- To find the Diagnosis report that was created by this job and that is stored in the Output repository of IMS Tools KB, see [“Finding Diagnosis reports by using report completion codes”](#) on page 208.

- b) Identify the cause of the database exceptions.

To identify the cause of database exceptions, see [“Identifying the cause of database exceptions”](#) on page 206.

4. If any database exceptions remain, resolve those exceptions.

If the remaining database exceptions are in severe-level or in critical-level, plan database tuning to resolve the database exceptions. For details, see [“Resolving database exceptions” on page 207](#).

## Running a job in Reorganization Diagnosis mode

---

You can run a Smart Reorg job in Reorganization Diagnosis mode to reorganize the database and check the status of the database before and after reorganization.

### Procedure

To run a Smart Reorg job in Reorganization Diagnosis mode, complete the following steps:

1. Prepare a reorganization policy for evaluating the database statistics.

For instructions for preparing a reorganization policy, see [“Preparing a reorganization policy” on page 205](#).

2. Code and submit JCL.

- a) Code the JCL stream for the Smart Reorg job.

If SPACEALLOC=YES is not specified, the JCL stream must include an IDCAMS step before the Smart Reorg job step. The IDCAMS step allocates a DASD space for each output (shadow) data set.

For more information, see [Chapter 8, “Smart Reorg JCL requirements,” on page 89](#).

- b) Specify the control statements in the HPSIN DD statement.

To run the job in Reorganization Diagnosis mode, specify CONDREORG=YES,REORGDIAG in the (REORG) block.

By default, the database statistics that reflect the state of database at the time when the Smart Reorg job started are collected dynamically. If you want to use the most recent database statistics that are already stored in the Sensor Data repository, specify DIAGDATAFROM=REPOSITORY in the (CONDREORG) block.

If you want to change the return code of the Smart Reorg job step that will be issued when a critical-level exception remains, specify the RC\_CHANGE control statement in the (REORG) block.

Specify other control statements. See [Chapter 9, “Smart Reorg control statements,” on page 117](#) for more information.

**Tip:** For information about control statements that can automate and reduce some of your manual operations, see [“Hints and tips for specifying control statements” on page 178](#).

- c) Submit the Smart Reorg JCL stream for the database.

3. Check the results of the job and determine if database exceptions exist in the database.

If you receive no exception notification messages, no further actions are required.

If you receive one or more exception messages, follow these steps:

- a) Check the outputs from the Smart Reorg utility.

- If you have customized the reorganization policy to send exception notification messages by using the z/OS WTO service or the TSO/E SEND command, check those messages that are issued by the Smart Reorg utility. Those messages include a job summary message (policy evaluation summary message) that summarizes the result of policy evaluation that was performed by Policy Services during the job. To check the policy evaluation summary message, see [“Checking the policy evaluation summary message” on page 205](#).

- To find the Diagnosis report that was created by this job and that is stored in the Output repository of IMS Tools KB, see [“Finding Diagnosis reports by using report completion codes” on page 208](#).

- b) Identify the cause of the database exceptions.

To identify the cause of database exceptions, see [“Identifying the cause of database exceptions” on page 206](#).

4. If any database exceptions remain, resolve those exceptions.

If the remaining database exceptions are in severe-level or in critical-level, plan database tuning to resolve the database exceptions. For details, see [“Resolving database exceptions” on page 207](#).

## Running a job in Diagnosis-only mode

---

You can run a Smart Reorg job in Diagnosis-only mode to check the status of the database.

### Procedure

To run a Smart Reorg job in Diagnosis-only mode, complete the following steps:

1. Prepare a reorganization policy for evaluating the database statistics.

For instructions for preparing a reorganization policy, see [“Preparing a reorganization policy” on page 205](#).

2. Code and submit JCL.

- a) Code the JCL stream for the Smart Reorg job.

For details, see [Chapter 8, “Smart Reorg JCL requirements,” on page 89](#).

- b) Specify the control statements in the HPSIN DD statement.

To run the job in Diagnosis-only mode, specify CONDREORG=YES,DIAGONLY in the (REORG) block.

By default, the database statistics that reflect the state of database at the time when the Smart Reorg job started are collected dynamically. If you want to use the most recent database statistics that are already stored in the Sensor Data repository, specify DIAGDATAFROM=REPOSITORY in the (CONDREORG) block.

If you want to change the return code of the Smart Reorg job step that will be issued when a critical-level exception remains, specify the RC\_CHANGE control statement in the (REORG) block.

Specify other control statements. See [Chapter 9, “Smart Reorg control statements,” on page 117](#) for more information.

- c) Submit the Smart Reorg JCL stream for the database.

3. Check the results of running the job and determine if database exceptions exist in your database.

If you receive no exception notification messages, no further actions are required.

If you receive one or more exception messages, follow these steps:

- a) Check the outputs from the Smart Reorg utility.

- If you have customized the reorganization policy to send exception notification messages by using the z/OS WTO service or the TSO/E SEND command, check those messages that are issued by the Smart Reorg utility. Those messages include a job summary message (policy evaluation summary message) that summarizes the result of policy evaluation that was performed by Policy Services during the job. To check the policy evaluation summary message, see [“Checking the policy evaluation summary message” on page 205](#).

- To find the Diagnosis report that was created by this job and that is stored in the Output repository of IMS Tools KB, see [“Finding Diagnosis reports by using report completion codes” on page 208](#).

- b) Identify the cause of the database exceptions.

To identify the cause of database exceptions, see [“Identifying the cause of database exceptions” on page 206](#).

4. If any database exceptions remain, resolve those exceptions.

If the database exceptions are in severe-level or in critical-level, plan database reorganization or tuning to resolve the database exceptions. For details, see [“Resolving database exceptions” on page 207](#).



---

## Chapter 8. Smart Reorg JCL requirements

To run a Smart Reorg job, code JCL statements that satisfy the following EXEC and DD statement requirements.

### Topics:

- [“EXEC statement” on page 89](#)
- [“DD statements” on page 90](#)
- [“Considerations for database data sets” on page 104](#)
- [“Considerations for DBD libraries” on page 108](#)
- [“Considerations for secondary indexes” on page 108](#)
- [“Considerations for logical relationships” on page 109](#)
- [“Considerations for Image Copy processing” on page 110](#)
- [“Considerations for HASH pointer checking” on page 114](#)
- [“Considerations for the IMS management of ACBs” on page 115](#)

## EXEC statement

---

The EXEC statement marks the beginning of a step within a job, and specifies the name of a program to be run.

The EXEC statement for the Smart Reorg utility must be in the following format:

```
//stepname EXEC PGM=HPSGMAIN,PARM='DBD=dbdname'
```

Specify HPSGMAIN as the program name. The PARM parameter must include the following keyword:

### **DBD=dbdname**

Specifies the name of the DBD that includes the database to reorganize. This parameter is required.

Optionally, you can specify the following keywords to specify the job step environment:

### **DBRC=x**

Specifies whether the Smart Reorg utility uses DBRC.

#### **Y**

DBRC is used.

#### **N**

DBRC is not used unless DBRC=FORCE was specified while the IMS system was being generated.

If this parameter is not specified, the default setting that is determined by the IMS system generation is used. IBM recommends that you activate DBRC for the Smart Reorg utility. Some functions are not available when DBRC is not active. DBRC must be active if you reorganize a HALDB or HALDB partitions.

### **IMSID=ssna**

Specifies the subsystem name of the IMS control region.

If this parameter is not specified, the default setting determined by the IMS system generation is used.

If you specify IMSCMD=YES, the Smart Reorg utility uses the IMS subsystem name to issue IMS commands. For details, see the following topics:

- [“IMSCMD control statement” on page 140](#)
- [“Setting up for using E-MCS console for IMS command processing” on page 50](#)

**IMSPLEX=name**

Specifies the IMSplex name that is to be used by IMS DBRC SCI Registration. This parameter is 1- to 5-characters.

**DBRCGRP=ccc**

Specifies the DBRC group identifier that is to be used by IMS DBRC SCI Registration. This parameter is three characters.

**SWAP=x**

Makes the address space swappable or non-swappable.

**Y**

The address space is made swappable.

**N**

The address space is made non-swappable.

The default is N. If you are reorganizing a HISAM, HDAM, or HIDAM database that has at least one secondary index, and you specify IC=YES, ICTYPE=A, and INDEXBLD=YES in the (REORG) block in the HPSIN data set, SWAP=N is forced even if you have SWAP=Y specified.

**IRLM=x**

Specifies whether the Unload task uses IRLM when native DL/I calls are issued for the database.

**Y**

IRLM is used.

**Note:** Even if IRLM=Y is specified, no locking support through IRLM is available when the database is read by the Unload task. IRLM is used only for native DL/I calls that might be issued in Unload tasks internally and that are processed by the DL/I buffer handler, not by HSSR Engine.

**N**

IRLM is not used.

If IRLM parameter is not specified, the default setting determined by the IMS system generation is used.

**IRLMNM=irlm**

Specifies the IRLM subsystem name (1-to-4 alphanumeric-character name), if you specify IRLM=Y.

If this parameter is not specified, the default settings determined by the IMS system generation is used.

**GSGNAME=gsgname**

Specifies the name of the global service group (GSG).

If this parameter is not specified, the default setting that is determined by the IMS system generation is used.

**DFSDF=ccc**

Specifies the 3-character suffix of the DFSDFccc member of the IMS.PROCLIB data set. You must also specify the PROCLIB DD statement.

**Note:** If you want to specify the IMSplex name, you can also use the DBRC SCI Registration exit. For details, see [“Setting up the DBRC command authorization”](#) on page 47.

## DD statements

---

DD statements are used to identify the source of input and the placement of output information.

The following table shows DD statements and record format for the Smart Reorg utility. The description of each DD statement follows the tables.

Table 5. DD statements and record format for the Smart Reorg utility

<b>DDNAME</b>	<b>Use</b>	<b>Format</b>	<b>Need</b>
STEPLIB	Input		Required
DFSRESLB	Input	Same as IMS	Optional (See <a href="#">Note 1</a> )
IMS	Input	Same as IMS	Optional
<i>new_dbdlib</i>	Input	Same as IMS DD	Optional (See <a href="#">Note 2</a> )
IMSDALIB	Input	Same as that is used in IMS control region startup JCL stream	Optional (See <a href="#">Note 3</a> )
<i>original_dbds</i>	Input	Depends on database organization	Optional (See <a href="#">Note 4</a> )
DFSVSAMP	Input	Same as IMS	Optional
RECONx	Input	Same as IMS	Optional (See <a href="#">Note 5</a> )
HPSIN	Input	LRECL=80, RECFM=FB	Optional
PROCLIB	Input	LRECL=80, RECFM=FB	Optional
DFSACBPD	Input	LRECL=80, RECFM=FB	Optional
HPSGCTL	Input	LRECL=800, RECFM=FB	Optional (See <a href="#">Note 6</a> )
DDEFPS2	Input	PDS or PDSE, LRECL=80, RECFM=FB	Optional
HPSGAMSA	Input	LRECL=80, RECFM=FB	Optional
HPSOUT	Output	LRECL=81, RECFM=FBA	Optional (See <a href="#">Note 7</a> )
HPSOUT2	Output	LRECL=133, RECFM=FBA	Optional (See <a href="#">Note 7</a> )
BBERPRT	Output	LRECL=81, RECFM=FA/FBA	Optional
BBEJRNL	Output	LRECL=133, RECFM=FA/FBA	Optional
BSNJM01	Output	LRECL=133, RECFM=FA/FBA	Optional
BBEERROR	Output	LRECL=133, RECFM=FA/FBA	Optional
<i>shadow_dbds</i>	Output	Depends on database organization	Optional (See <a href="#">Note 4</a> )
HPSGSWAP	Output	LRECL=80, RECFM=FB	Optional
HPSGDBRC	Output	LRECL=80, RECFM=FB	Optional
HPSSNAP	Output	LRECL=133	Optional (See <a href="#">Note 7</a> )
HPSDSPAP	Output	LRECL=133, RECFM=FBA	Optional
SYSUDUMP	Output	LRECL=133	Optional

The following table shows DD statements and record format for the Unload task.

Table 6. DD statements and record format for the Unload task

DDNAME	Use	Format	Need
HPSLIST	Output	LRECL=133, RECFM=FBA	Optional (See <a href="#">Note 7</a> )
HPSRAPC	Output	RECL=81, RECFM=FBA	Optional Required if RAPCHECK=YES (See <a href="#">Note 7</a> )
HPSTRACE	Output	LRECL=133	Optional (See <a href="#">Note 7</a> )
SYSUT3	Output	See SYSUT3 description.	Optional (See <a href="#">Note 8</a> )
SYSUT4	Output	See SYSUT4 description.	Optional (See <a href="#">Note 8</a> )

The following table shows DD statements and record format for the Reload task.

Table 7. DD statements and record format for the Reload task

DDNAME	Use	Format	Need
DFSUINPT	Input if REORGINPUT=ULDS		Optional
HPSSTAT	Output	LRECL=81, RECFM=FBA	Optional (See <a href="#">Note 7</a> )
DFSURWF1	Output Used as both input and output if PREFIXRES=YES	Same as IMS	Optional (See <a href="#">Note 9</a> )
HPSRSIDX	Output	Same as DFSURWF1 DD	Optional (See <a href="#">Note 9</a> )
HPSRP $nnn$	Output	LRECL=7250, RECFM=FB	Optional (See <a href="#">Note 10</a> )
SEQERROR	Output		Optional (See <a href="#">Note 11</a> )
OVERFLOW	Input/Output	RECFM=VB	Optional (See <a href="#">Note 5</a> )
HPSRISMG	Output	LRECL=133	Optional
HPSRILEA	Input/Output		Optional
HPSRILEB	Input/Output		Optional
HPSRWK $nn$	Input/Output		Optional

The following table shows DD statements and record format for the Index Builder task.

Table 8. DD statements and record format for the Index Builder task

DDNAME	Use	Format	Need
<i>sindex</i>	Output	KSDS	Optional (See <a href="#">Note 4</a> )
IIUPRINT	Output	LRECL=133	Optional (See <a href="#">Note 7</a> )
IIUCAPT	Output	LRECL=133	Optional (See <a href="#">Note 7</a> )
IIUDUMP	Output	LRECL=125, RECFM=VBA	Optional (See <a href="#">Note 12</a> )
IIUSNAP	Output	LRECL=133	Optional (See <a href="#">Note 7</a> )
IIUSOUT	Output	LRECL=133, RECFM=FB	Optional (See <a href="#">Note 7</a> )

The following table shows DD statements and record format for logical relationship processing.

Table 9. DD statements and record format for logical relationship processing

DDNAME	Use	Format	Need
DFSURCDS	Input	LRECL=1600	Optional
SORTLIB	Input		Optional
FABYPRNT	Output	LRECL=133, RECFM=FBA	Optional (See Note 7)
FABYMSG	Output	LRECL=133, RECFM=FBA	Optional (See Note 7)

The following table shows DD statements and record format for Image Copy processing.

Table 10. DD statements and record format for Image Copy processing

DDNAME	Use	Format	Need
ICEIN	Input	LRECL=80	Optional
ICEPRINT	Output	LRECL=133	Optional (See Note 7)
DFSPRINT	Output	LRECL=122	Optional (See Note 7)
ICERPRT	Output	LRECL=133	Optional (See Note 7)
<i>dataout1/stack1</i>	Output	RECFM=FB, VBS, or U	Optional
<i>dataout2/stack2</i>	Output	RECFM=FB, VBS, or U	Optional

The following table shows DD statements and record format for Hash Pointer Check processing.

Table 11. DD statements and record format for Hash Pointer Check processing

DDNAME	Use	Format	Need
PRIMAPRT	Output	LRECL=133	Optional (See Note 7)
STATIPRT	Output	LRECL=133	Optional (See Note 7)
VALIDPRT	Output	LRECL=133	Optional (See Note 7)
EVALUPRT	Output	LRECL=133	Optional (See Note 7)
SNAPPIT	Output	LRECL=133	Optional (See Note 7)
SUMMARY	Output	LRECL=133	Optional (See Note 7)
HISTORY	Output	KSDS	Optional

**Notes for Table 5 on page 91 to Table 11 on page 93**

1. If a library in the STEPLIB concatenation is not APF-authorized, the DFSRESLB DD statement is required.
2. The DD statement is required only when the NEWDBD control statement is specified in the HPSIN data set.
3. IMSDALIB DD statement is valid for RECON data sets and original data sets of non-HALDB database and its indexes. This DD statement is ignored for HALDB.
4. If you use dynamic allocation, do not specify the DD statement. Original database data sets (*original\_dbds*) of HALDB are always allocated dynamically. For details, see the explanation of each DD statement.
5. If you use dynamic allocation, you do not need to specify the DD statement.
6. The DD statement is required if the Post-reorganization utility is used for post-reorganization processing.

7. It is recommended that you do not specify these DD statements. If these DD statements are not specified, the Smart Reorg utility dynamically allocates these DD statements to SYSOUT streams.
8. You must code the DD statement for each DD name, other than SYSUT2, specified on the OUTPUT control statement for the Unload task. If you select format \*NO for output (OUTPUT=*outputdd*,\*NO), the DD statement for output does not need to be coded.
9. If both of these DD statements are coded, the logical relationship maintenance records are written to the DFSURWF1 data set, and the secondary index maintenance records are written to the HPSRSIDX data set. For details, see the explanation of each DD statement.
10. The DD statement is required only when the WFPHLQ control statement is specified in the (RELOAD) block of the HPSIN data set. If this DD statement is not specified, the data set is allocated dynamically.
11. The DD statement is required when SEQERROR=SAVE is specified for the Reload task.
12. The DD statement is used to generate the SNAP dump in the Index Builder task. If this DD statement is not specified, the data set is allocated dynamically in the Index Builder task.

In addition to the DD names that are listed in [Table 5 on page 91](#) through [Table 11 on page 93](#), the following DD names and any DD name that starts with BBE, BSN, FAB, FOI, DFS, HKT, HPS, IIU, or SYS are reserved for system use:

- INDXMSG (used internally by IMS HP Prefix Resolution)
- LPLCMMSG (used internally by IMS HP Prefix Resolution)
- TWINMSG (used internally by IMS HP Prefix Resolution)
- DBDEFCTL (this DD statement must not be coded)
- FORMULA (this DD statement must not be coded)
- FSESTAT (used internally by IMS HP Pointer Checker)
- DBDEFxxx (used internally by IMS HP Pointer Checker)
- FSESTAx (used internally by IMS HP Pointer Checker)
- SNAPPIdx (used internally by IMS HP Pointer Checker)
- STATIxxx (used internally by IMS HP Pointer Checker)
- VALIDxxx (used internally by IMS HP Pointer Checker)

Where xx represents two characters and xxx represents three characters.

When the Smart Reorg utility dynamically allocates DD statements for output data sets, it is done in the following order:

1. HPSOUT
2. HPSSTAT (allocated if STATRL=YES)
3. IIUPRINT (allocated if INDEXBLD=YES or PSINDEXBLD=YES)
4. IIUCAPT (allocated if INDEXBLD=YES or PSINDEXBLD=YES)
5. IIUSNAP (allocated if INDEXBLD=YES or PSINDEXBLD=YES)
6. IIUSOUT (allocated if INDEXBLD=YES or PSINDEXBLD=YES)
7. FABYPRNT (allocated if PREFIXRES=YES)
8. FABYMSG (allocated if PREFIXRES=YES)
9. ICEPRINT (allocated if IC=YES)
10. DFSPRINT (allocated if IC=YES)
11. ICERPRT (allocated if IC=YES)
12. PRIMAPRT (allocated if IC=YES and either HDPC=Y or HDPC=O is specified for at least one data set)
13. STATIPRT (allocated if IC=YES and either HDPC=Y or HDPC=O is specified for at least one data set)
14. VALIDPRT (allocated if IC=YES and either HDPC=Y or HDPC=O is specified for at least one data set)

15. EVALUPRT (allocated if IC=YES and either HDPC=Y or HDPC=O is specified for at least one data set)
16. SNAPPIT (allocated if IC=YES and either HDPC=Y or HDPC=O is specified for at least one data set)
17. SUMMARY (allocated if IC=YES and either HDPC=Y or HDPC=O is specified for at least one data set)
18. HPSOUT2
19. HPSLIST (allocated if STATUL=YES)
20. HPSTRACE (allocated if DIAGG=YES or the TRACE statement is specified in the (UNLOAD) block)
21. HPSSNAP
22. BBERPRT (allocated if CONDREORG=YES)
23. HPSDSPAP
24. BBEERROR (allocated if KEYLABELCHK=YES)
25. HPSRAPC (allocated if RAPCHECK=YES is specified in the (UNLOAD) block)

## DD names common to all processing options

This topic describes DD names that are common to all processing options.

### STEPLIB DD

Points to the following library data sets:

- IMS Tools product libraries:
  - IMS Database Reorganization Expert load module library (required)
  - IMS HP Unload load module library (required)
  - IMS HP Load load module library (required)
  - IMS Index Builder load module library (optional)
  - IMS Library Integrity Utilities load module library (optional)
  - IMS HP Image Copy load module library (optional)
  - IMS HP Pointer Checker load module library (optional)
  - IMS HP Prefix Resolution load module library (optional)
  - IMS Tools Online System Interface load module library (optional)
  - The SHKTLOAD library of IMS Tools Base (optional). This library contains the load modules for IMS Tools KB, Policy Services, and Autonomics Director.

**Tip:** You can specify the library in the ITKBLOAD control statement instead of including it in the STEPLIB concatenation. However, when you use the CRSS or Autonomics Director, you must include the load module library of IMS Tools KB in the STEPLIB concatenation.

- The SGLXLOAD library of IMS Tools Base (optional)
- IMS RESLIB library (required)
- The library that contains DFSMDA members for dynamic allocation (optional)

**Note:** If you specify this library on the IMSDALIB DD statement, it is highly recommended that you remove the library from the STEPLIB concatenation.

- The load module library that contains user routines (optional)
- The library that contains the Installation Default Option Table (HPSGOPTI) (optional)

IMS Tools product libraries must be concatenated before the IMS RESLIB library.

If you specify one or more of the following options, the libraries that are specified on the STEPLIB DD statement must be APF-authorized:

- COMPAUTH=YES
- CONDREORG=YES
- CONDREORG=YES,REORGDIAG

- CONDREORG=YES,DIAGONLY
- HPIO=YES
- IMSCMD=YES
- INDEXBLD=YES
- PSINDEXBLD=YES
- SPACEALLOC=YES
- ZIIPMODE=COND

If none of these options are specified and if any of the libraries are not APF-authorized, the Smart Reorg utility applies HPIO=NO and continues processing. In this case, the DFSRESLB DD statement is required.

#### **DFSRESLB DD**

Points to the authorized library that contains IMS SVC modules. For an IMS Database Reorganization Expert job, IMS RESLIB library and any data set that is concatenated to it on the DFSRESLB DD statement must be APF-authorized. For details, see the topic that explains how to specify the DFSRESLB DD statement in IMS batch procedures in *IMS System Definition*.

#### **IMS DD**

Describes the library containing the DBD that is specified by the DBD= subparameter of the PARM parameter for HPSGMAIN and the DBD that is used when the database is unloaded. This data set must reside on a direct-access device. For details, see [“Considerations for DBD libraries” on page 108](#).

If the IMS management of ACBs is enabled, IMS DD statement is ignored.

#### **new\_dbdlib DD**

Describes the optional DBD library containing the DBD that is to be used when the database is reloaded and when the indexes are rebuilt by INDEXBLD=YES or PSINDEXBLD=YES. This data set must reside on a direct-access device. For details, see [“Considerations for DBD libraries” on page 108](#).

#### **IMSDALIB DD**

Specifies the partitioned data set or data sets that contain dynamic allocation members for the database data sets of non-HALDB and RECON data sets.

If DBRC is active and the IMSDALIB control statement is present, IMSDALIB is always referred to by DBRC, and DBRC determines the data sets to allocate for each RECON DD.

For the database data sets of non-HALDB, IMSDALIB is referred to only when the dynamic allocation of the original data sets is requested by the DYNALLOC control statement. For details, see [“DYNALLOC control statement” on page 136](#). Dynamic allocation of database data sets is attempted in the following order:

1. Dynamic allocation members in the IMSDALIB concatenation
2. Dynamic allocation members in JOBLIB or STEPLIB concatenation

In the Data Set Information report, the table named DATA SETS USED BY EACH TASK shows how the database and index data sets are allocated. For details, see [“Data Set Information report” on page 259](#).

**Note:** The library containing the DFSMDA member of TYPE=CATDSDLQ must be concatenated to the STEPLIB DD statement.

#### **original\_dbds DD**

Defines the database data set when the database to be reorganized is not a HALDB. One statement of this type must be present for each data set in the DBD that describes the database. The DD name must match the DD name in the DBD.

For HIDAM database, DD statements must also exist for the data sets that represent the index. DD statements that relate to the index must contain DD names specified in the DBD for the index database.



If a data set is specified, it must reside on a direct-access device. If you use dynamic allocation, do not code the DD statement for database data sets. You must not specify the DD statements for HALDB data sets because HALDB data sets are registered in RECON and are always allocated dynamically. For details, see [“Considerations for database data sets”](#) on page 104.

If the DD statement is coded, you must not code `DCB=BUFNO=n` or `AMP='BUFND=n'` to request access method buffers for database data sets because HSSR Engine of IMS HP Unload allocates its own buffer pools.

#### **DFSVSAMP DD**

Describes the data set that contains the buffer pool information required by the IMS DL/I buffer handler. This data set, when not specified, is created dynamically by IMS Database Reorganization Expert. Therefore, generally, do not specify this data set.

If you want to provide this data set, you should specify the minimum required number of buffers in the DFSVSAMP data set because IMS Database Reorganization Expert does not use the buffers allocated with the parameters specified in this data set. Otherwise, a larger number of the region size is required to run IMS Database Reorganization Expert.

However, you should specify sufficient DL/I buffers in DFSVSAMP when you specify the `BLDLPCK=YES` control statement for Unload task because DL/I calls are issued internally to build LPCKs in that case. The typical DFSVSAMP definitions should be used in tuning the processing of these internal DL/I calls.

If you want XTLOT (extended task input/output table) to be used for dynamically allocating each HALDB data set, code the `DBALLABOVE` statement in the DFSVSAMP DD statement. For more information, see [“DYNALLOC control statement”](#) on page 136.

#### **RECONx DD**

Defines DBRC RECON data sets. RECON data sets must be the same as the ones the online system is using. Do not use these RECON data set DD names if you want to have them allocated dynamically. IBM recommends that you have IMS Database Reorganization Expert allocate these data sets dynamically.

#### **HPSIN DD**

Defines an optional data set that contains control statements that specify options for Reorganization Manager, Unload task, Reload task, Index Builder task, and Prefix Resolution task. For details, see Chapter 9, [“Smart Reorg control statements,”](#) on page 117.

#### **PROCLIB DD**

Points to the IMS.PROCLIB data set. If you specify `DFSDF=ccc` in the EXEC statement, you must also specify this DD statement and ensure that the `DFSDFccc` member exists in the IMS.PROCLIB data set.

#### **DFSACBPD DD**

Defines the control statement data set to be used in an IMS-managed ACBs environment. `STAGING` is the only valid keyword and is applied when `REORGINPUT=ULDS` is specified in the (REORG) block of the HPSIN data set. The keyword specifies to obtain the database definition from the IMS catalog staging data sets and not from the IMS catalog directory data sets.

#### **HPSGCTL DD**

Defines the control data set that contains the data that the Pre-reorganization utility generates. You must specify this DD statement if you use the Post-reorganization utility for post-reorganization processing. This data set must reside on a direct-access device.

#### **DDEFPS2 DD**

Specifies the partitioned data set that contains IDCAMS commands for deleting and allocating each shadow space. This data set is optional and is used if `SPACEALLOC=YES` is specified. For details, see [“SPACEALLOC control statement”](#) on page 156.

#### **HPSGAMSA DD**

Defines the optional data set that contains IDCAMS commands for deleting and allocating DASD space for output data sets. For details, see [“SPACEALLOC control statement”](#) on page 156.

This DD statement is mutually exclusive with the DDEFPS2 DD statement.

**HPSOUT DD**

Defines the primary statistics output data set. The data set contains reports and statistics produced by the Unload and Reload tasks. The data set can reside on a tape, a direct-access device, or it can be routed through the output stream. If the DD statement is not coded, it is dynamically allocated to the SYSOUT stream of the output class that is specified by the MSGCLASS parameter on the JOB statement. For details, see [“HPSOUT data set” on page 240](#).

**HPSOUT2 DD**

Defines the secondary statistics output data set. The data set contains reports and statistics produced by Reorganization Manager. The data set can reside on a tape, a direct-access device, or it can be routed through the output stream. If the DD statement is not coded, it is dynamically allocated to the SYSOUT stream of the output class that is specified by the MSGCLASS parameter on the JOB statement. For details, see [“HPSOUT2 data set” on page 254](#).

**BBERPRT DD**

Defines the optional data set that contains the Database Diagnosis report or the Partition Diagnosis report that is generated by the conditional reorganization job.

**BBEJRN DD**

Defines the optional data set that contains journal messages issued by DB Analyzer and DB Sensor.

**BSNJM01 DD**

Defines the optional data set that contains journal messages issued by Policy Services. For information about allocating this data set, see the topic "Journal report overview" in the *IMS Tools Base Policy Services User's Guide and Reference*.

**BBEERROR DD**

Defines the optional data set that contains the Data Set Allocation Error - KEYLABEL report or the Data Set Deletion Error - KEYLABEL report that is generated by the conditional reorganization job.

**shadow\_dbds DD**

Defines data sets for the output shadow database to which the database is reloaded.

For HIDAM or PHIDAM database, DD statements must also exist for the data sets that represent the shadow primary index. For PHDAM or PHIDAM database, DD statements must also exist for the data sets that represent the shadow ILDSs if ILDSBLD=NO is not specified.

If you use dynamic allocation for shadow data sets, do not code the DD statements.

The data set must reside on a direct-access device. For details about how DD names for shadow database data sets are determined, see [“Considerations for database data sets” on page 104](#).

**HPSGSWAP DD**

Defines the optional output data set that contains IDCAMS command stream for data set name swapping. The command stream is produced only when manual name swapping is necessary. Also when any error occurs during the automated name swapping and the backout processing is not done by Smart Reorg utility, the IDCAMS command stream for the manual backout processing is produced in this data set. The data set is intended to be used as the SYSIN data set for the IDCAMS utility in another job step.

**HPSGDBRC DD**

Defines the optional output data set that contains the DBRC Notification Command Stream report. The command stream is produced only when manual name swapping is needed. The data set is intended to be used as the SYSIN data set for the DSPURX00 utility in another job step.

**HPSSNAP DD**

Defines the optional snap dump data set. If DBDSNAP=YES is coded in the (RELOAD) block but this DD statement is not coded, it is dynamically allocated to the SYSOUT stream of the same output class as the MSGCLASS that is specified on the JOB statement. For details, see [“HPSSNAP data set” on page 281](#).

**HPSDSPAP DD**

Defines the optional output data set that contains IMS DBRC error messages from DBRC API requests. If this DD statement is not coded, it is dynamically allocated to the SYSOUT stream of the output class that is specified by the MSGCLASS parameter on the JOB statement.

**SYSUDUMP DD**

Defines the dump data set. Most errors encountered end the program by issuing an ABEND macro with the DUMP operand. Only a SYSUDUMP DD statement is needed, the SYSABEND DD statement is not required.

**DD names for the Unload task**

This topic describes DD names used for the Unload task.

**HPSLIST DD**

Defines the data set to which the statistics produced by HSSR Engine of IMS HP Unload are written. The data set can reside on a tape, a direct-access device, or it can be routed through the output stream. If STATUL=YES is specified in the (REORG) block without this DD statement, this DD statement is dynamically allocated to the SYSOUT stream of the same output class as the MSGCLASS that is specified on the JOB statement. For details, see [“HPSLIST data set” on page 271](#).

**HPSRAPC DD**

Defines the optional output data set to which the check report is written when RAPCHECK=YES is specified. The data set can reside on a tape, a direct-access device, or it can be routed through the output stream. For details, see [Chapter 28, “IPR Unload reports,” on page 409](#).

**HPSTRACE DD**

Defines the trace output data set for the Unload task. It is required whenever DIAGG=YES or TRACE option is activated for the Unload task. The data set can reside on a tape, a direct-access device, or it can be routed through the output stream. If this DD statement is not coded, it is dynamically allocated to the SYSOUT stream of the same output class as the MSGCLASS that is specified on the JOB statement. For details, see [“HPSTRACE data set” on page 281](#).

**SYSUT3 DD****SYSUT4 DD**

Define the optional unload data sets for the DD name specified in the OUTPUT control statement for the Unload task. The unloaded segment records that are formatted as specified in the OUTPUT statement are written to the specified data set. For the details on how to specify the OUTPUT control statement, see [“OUTPUT control statement” on page 375](#).

Each data set must reside on a magnetic tape or a direct-access device. If block size is not specified on the DD statement, IMS Database Reorganization Expert uses the half track size for each device type. If the database contains segments larger than the block size, the maximum block size 32 K is used. Do not specify the LRECL value on the DD statement. IMS Database Reorganization Expert uses the default record size (block size minus 4). For details, see the explanation of SYSUT3 and SYSUT4 DD statements in [“DD statements” on page 360](#).

**DD names for the Reload task**

This topic describes DD names used for the Reload task.

**DFSUINPT DD**

If REORGINPUT=ULDS is specified, this DD statement is required. It defines the input data set that contains the data to be reloaded. This is the data set that is created by the IPR Unload utility or other equivalent utilities. The data set must reside on either a tape or a direct-access device.

**HPSSTAT DD**

Defines the optional output data set that contains comprehensive statistics of reloaded segments and pointers. The statistics are produced by the Reload task. The data set can reside on a tape or a direct-access device, or it can be routed through the output stream. If STATRL=YES is specified in the (REORG) block without this DD statement, this DD statement is dynamically allocated to the SYSOUT stream of output class that is specified by the MSGCLASS parameter on the JOB statement. For details, see [“HPSSTAT data set” on page 271](#).

**DFSURWF1 DD**

Defines the work data set to be created by the Reload task or the Index Builder task when the database to be reorganized is not a HALDB. The data set is used as an input to utilities to resolve logical or secondary index relationships. It must reside either on a tape or a direct-access device.

This DD statement is required if at least one of the following conditions is met:

- The database is HDAM, HIDAM, or HISAM and it has logical relationships
- The database has a secondary index and INDEXBLD=NO is specified, but the HPSRSIDX DD statement is not coded

**Note:** If WF1REC=NO is specified, you can omit this DD statement.

If the preceding condition is not met, this DD statement is not required.

For an HDAM or a HIDAM database that has internal logical relationships and that has no external logical relationships, you can specify a temporary data set on the DFSURWF1 DD statement if PREFIXRES=YES is coded in the (REORG) block and one of the following conditions is met:

- The database has no secondary index
- The database has a secondary index and INDEXBLD=YES is specified
- The database has a secondary index and INDEXBLD=NO is specified and the HPSRSIDX DD statement is present

In these cases, the data set specified on the DFSURWF1 DD statement is used as the input to the Prefix Resolution task invoked internally in the Smart Reorg job step.

For details about logical relationship processing, see [“Considerations for logical relationships” on page 109.](#)

#### **HPSRPnnn DD**

Defines the WFP work data sets to be created in the Reload task. These data sets are used for rebuilding partitioned secondary indexes (PSINDEXes) in the index building task, and they are created only when the WFPHLQ control statement is specified in the (RELOAD) block of the HPSIN data set. The created data sets can be used as input to stand-alone IMS Index Builder jobs to rebuild PSINDEXes. If you do not specify this statement, the data sets are allocated dynamically. For more information, see the description of the HPSRPnnn DD in [Chapter 34, “IPR Reload JCL requirements,” on page 491.](#)

**Tip:** If you specify PSINDEXBLD=YES in the (REORG) block, PSINDEXes are rebuilt without WFP work data sets. Therefore, when you specify PSINDEXBLD=YES, you can omit the WFPHLQ control statement and HPSRPnnn DD statements.

#### **HPSRSIDX DD**

If INDEXBLD=NO is specified, this data set contains unsorted secondary index maintenance records for the database that has a secondary index. The DD statement is optional. If this DD statement is not coded, index maintenance records are written to the data set that is specified on the DFSURWF1 DD statement. If the database has no secondary index or INDEXBLD=YES is specified, this DD statement is not required.

#### **SEQERROR DD**

Defines a sequential output data set in which segment data in key sequence error is to be kept. This data set is required only when SEQERROR=SAVE is specified for the Reload task. This data set saves segments in key sequence error and their hierarchical dependent segments.

For details about the SEQERROR control statement, see [“SEQERROR control statement” on page 527.](#) For information about the requirements for this DD statement, see the description of SEQERROR DD statement in [Chapter 34, “IPR Reload JCL requirements,” on page 491.](#)

#### **OVERFLOW DD**

Defines the optional sequential data set that is used as a temporary storage to keep database blocks that are directed to the overflow area during HDAM RAA reloading. Such blocks are written into the overflow area after RAA reloading is completed. This data set is used only when both OADSPR=Y and HPIO=N are specified. If you specify both OADSPR=Y and HPIO=N and this DD statement is not coded, the Reload task attempts to allocate the overflow data set dynamically. This data set must reside on either a tape or a direct-access device.

**HPSRISMG DD**

This optional output data set contains messages issued by DFSORT. This data set is used only when ILDSBLD=YES, DSPR is specified. If this DD statement is omitted, the data set is allocated dynamically.

**HPSRILEA DD****HPSRILEB DD**

These data sets are used by DFSORT, as substitute for SORTIN data sets, when ILDSBLD=YES, DSPR is specified. If you do not specify the statement, the data sets are allocated dynamically with sizes estimated based on the allocation size of ILDS.

To avoid space shortage problems that might be caused by extension of the data sets, the size estimation is adjusted as follows:

- If the high-used RBA of ILDS is greater than the primary space amount, the equivalent amount is specified as the primary space amount.
- If the secondary space amount is less than 1/5 of the high used RBA of ILDS, the equivalent amount is specified as the secondary space amount.
- If the primary or secondary space amount of ILDS is less than 100 cylinders, 100 cylinder is used as the space amount.
- The data set is allocated with volume count so that it can be extended on up to 10 volumes.

You can specify the data class and the storage class for HPSRILEA and HPSRILEB by using ILEDATAC and ILESTORC control statements.

A dummy data set or the DISP=MOD parameter cannot be specified on the HPSRILEA DD or HPSRILEB DD statement.

For more information about SORTIN data sets, see the *DFSORT Application Programming Guide*.

**HPSRWKnn DD**

These data sets are used by DFSORT, as substitute for SORTWK data sets, when ILDSBLD=YES, DSPR is specified. *nn* shows its serial number. If you do not specify the statement, the data sets are allocated dynamically by DFSORT.

For more information, see the *DFSORT Application Programming Guide*.

## DD names for the Index Builder task

This topic describes DD names used for the Index Builder task. These DD statements are not necessary if INDEXBLD=YES or PSINDEXBLD=YES is not specified.

**sindex DD**

Defines the output data sets for all secondary indexes to be rebuilt. If INDEXBLD=YES or PSINDEXBLD=YES is specified and the dynamic allocation of the data sets are not designated, the DD statements must be specified. The DD names must be those defined in the DBD that is to be used for the Index Builder task. The data set must reside on a direct-access device. If you use dynamic allocation, do not code the DD statement for the database data sets. For details, see [“Secondary indexes”](#) on page 106.

**IIUPRINT DD**

Defines the primary statistics output data set for the Index Builder task. The data set contains reports and statistics produced by IMS Index Builder. When the DD statement is omitted, the DD statement is dynamically allocated to the SYSOUT stream of the output class specified by the MSGCLASS parameter on the JOB statement.

**IIUCAPT DD**

This output file contains the combined WTO messages from the sort address spaces that are involved in the process. If the DD statement is not coded, the DD statement is dynamically allocated to the SYSOUT stream of the output class that is specified by the MSGCLASS parameter on the JOB statement.

**IIUDUMP DD**

This output file contains a dump that is generated as the result of an error.

**IIUSNAP DD**

This output file contains major processing event logs. This DD statement is optional, and if the DD statement is not coded, the DD statement is dynamically allocated to the SYSOUT stream of the output class specified by the MSGCLASS parameter on the JOB statement.

**IIUSOUT DD**

Defines the sort output data set for the Index Builder task. The data set contains the output from each sort task attached or started by the Index Builder task. If a sort error is encountered, this file must be inspected because it contains detailed sort messages.

If the DD statement is not coded, the DD statement is dynamically allocated to the SYSOUT stream of the output class that is specified by the MSGCLASS parameter on the JOB statement.

## DD names for logical relationship processing

This topic describes DD names that are used for logical relationship processing.

For the description of the DFSURWF1 DD statement, see [“DD names for the Reload task” on page 99](#).

**DFSURCDS DD**

Defines the control data set that contains the data generated by IMS Database Prereorganization utility (DFSURPRO). This DD statement must be specified if the database to be reorganized has a logical relationship. This data set must reside on either a tape or a direct-access device. The DD statement is not required when a HALDB is reorganized. For details about the data sets that are used for the logical relationship maintenance, see [“Considerations for logical relationships” on page 109](#).

**SORTLIB DD**

Defines the library that contains load modules of operating system sort/merge modules. This DD statement is optional and is not required if the sort library is a part of the system LINKLIB.

**FABYPRNT DD**

Defines the output data set that contains reports and statistics produced by IMS HP Prefix Resolution. DCB parameters specified within this program are RECFM=FBA and LRECL=133. If BLKSIZE is provided on the FABYPRNT DD statement, it must be a multiple of 133. This DD statement is optional, and if the DD statement is not coded and PREFIXRES=YES is specified in the (REORG) block of HPSIN DD, a SYSOUT stream is dynamically allocated for the DD.

**FABYMSG DD**

Defines the output data set that contains messages issued by the sort/merge program that is invoked internally by IMS HP Prefix Resolution. This DD statement is optional, and if the DD statement is not coded and PREFIXRES=YES is specified in the (REORG) block of HPSIN DD, a SYSOUT stream is dynamically allocated for the DD.

## DD names for Image Copy processing

This topic describes DD names that are used for Image Copy processing.

**ICEIN DD**

Specifies the input data set that contains control statements for the Image Copy task. The data set can reside on a tape, a direct-access volume, or it can be routed through the input stream (DD \* or DD DATA). This DD statement is optional. If IC=YES is specified in the (REORG) block of the HPSIN data set and the ICEIN DD statement is not coded, the default control statements are used. For details about the ICEIN control statements, see [“Control statements for the Image Copy task” on page 177](#).

**ICEPRINT DD**

Specifies the output data set that contains reports produced by IMS HP Image Copy. The data set can reside on a tape, a direct-access volume, or a printer, or it can be routed through the output stream (SYSOUT). This DD statement is optional, and if the DD statement is not coded and IC=YES is specified in the (REORG) block of HPSIN DD, a SYSOUT stream is dynamically allocated for the DD.

**ICERPRT DD**

Specifies the output data set that contains the Image Copy Dump Process report that is produced by IMS HP Image Copy. It can reside on a tape, a direct-access volume, or a printer, or it can be routed through the output stream (SYSOUT). This DD statement is optional, and if the DD statement is not

coded and IC=YES is specified in the (REORG) block of HPSIN DD, a SYSOUT stream is dynamically allocated for the DD.

#### **DFSPRINT DD**

Specifies the output data set that contains messages issued by IMS HP Image Copy. The data set can reside on a tape, a direct-access volume, or a printer, or it can be routed through the output stream (SYSOUT). This DD statement is optional, and if the DD statement is not coded and IC=YES is specified in the (REORG) block of HPSIN DD, a SYSOUT stream is dynamically allocated for the DD.

#### **dataout1/stack1 DD**

Defines the primary image copy data set. One DD statement is required for each data set to be dumped. The DD name can be any 1- to 8-character string. The data set specified by the DD statement must be on either a direct-access device or a tape device.

For details about the format and the characteristics of image copy data sets, see the *IMS High Performance Image Copy User's Guide*.

You can request IMS HP Image Copy to allocate the image copy data set dynamically by omitting this DD statement and specifying the allocation parameters that are associated with the data set in the ICEIN data set. If you select Type-A Image Copy for a secondary index database, you cannot code the DD statement for the image copy data set on a tape device.

#### **dataout2/stack2 DD**

These DD statements are required only if the associated ICEIN control statement requests the secondary image copy. The data set specified by the DD statement must be on either a direct-access device or a tape device. For details about the format and the characteristics of image copy data sets, see the *IMS High Performance Image Copy User's Guide*. If you select Type-A Image Copy for a secondary index database, you cannot code the DD statement for the image copy data set on a tape device.

## **DD names for HASH pointer check processing**

This topic describes DD names that are used for HASH pointer checking processing.

#### **PRIMAPRT DD**

Defines the output data set that contains the primary reports that are produced by IMS HP Pointer Checker. If the BLKSIZE is coded on the DD statement, it must be a multiple of 133. If the DD statement is not coded and HDPC=Y is specified in an image copy control statement that is specified in the ICEIN data set, a SYSOUT stream is dynamically allocated for the DD.

#### **STATIPRT DD**

Defines the output data set that contains some of the statistical reports that are produced by IMS HP Pointer Checker. If BLKSIZE is coded on the DD statement, it must be a multiple of 133. If the DD statement is not coded and HDPC=Y is specified in an image copy control statement that is specified in the ICEIN data set, a SYSOUT stream is dynamically allocated for the DD.

#### **VALIDPRT DD**

Defines the output data set that contains the legends and the validation reports that are produced by IMS HP Pointer Checker. If BLKSIZE is coded on the DD statement, it must be a multiple of 133. If the DD statement is not coded and HDPC=Y is specified in an image copy control statement that is specified in the ICEIN data set, a SYSOUT stream is dynamically allocated for the DD.

#### **EVALUPRT DD**

Defines the output data set that contains evaluation reports that are produced by IMS HP Pointer Checker. If BLKSIZE is coded on the DD statement, it must be a multiple of 133. If the DD statement is not coded and HDPC=Y is specified in an image copy control statement that is specified in the ICEIN data set, a SYSOUT stream is dynamically allocated for the DD.

#### **SNAPPIT DD**

Defines the output data set that contains the block maps and block dumps that are produced by IMS HP Pointer Checker. If BLKSIZE is coded on the DD statement, it must be a multiple of 133. If the DD statement is not coded and HDPC=Y is specified in an image copy control statement that is specified in the ICEIN data set, a SYSOUT stream is dynamically allocated for the DD.



## SUMMARY DD

Defines the output data set that contains the HD Pointer Checker Summary report that is produced by the IMS HP Pointer Checker. If BLKSIZE is coded on the DD statement, it must be a multiple of 133. If the DD statement is not coded and HDPC=Y is specified in an image copy control statement that is specified in the ICEIN data set, a SYSOUT stream is dynamically allocated for the DD.

## HISTORY DD

This optional data set defines a HISTORY data set, which is used as the input to the DB Historical Data Analyzer and Space Monitor of IMS HP Pointer Checker. This data set is a VSAM KSDS, and it must be allocated and initialized by the DB Historical Data Analyzer utility before running a Smart Reorg job. If the HISTORY option is specified on the HDPC subparameter of an image copy control statement in the ICEIN data set, the HISTORY data set with DISP=SHR is required. For details, see the *IMS High Performance Pointer Checker User's Guide*.

## Considerations for database data sets

---

Reorganization Manager of the Smart Reorg utility uses database data sets and DD names in specific ways. This topic helps you build your JCL correctly.

The following items are discussed in this topic:

- How to specify DD names and data set names of original data sets and shadow data sets<sup>1</sup> for database and primary index.
- How to specify DD names and data set names for secondary indexes to be built by the Index Builder task.
- How the names of the output data sets<sup>2</sup> for a database are determined and how they are allocated dynamically.
- Restrictions on data set names.
- Data set names after reorganization.
- Deleting original data sets.

See also [“NAMESWAP control statement” on page 147](#).

Subsections:

- [“Database, primary index, and ILDS” on page 104](#)
- [“Secondary indexes” on page 106](#)
- [“Dynamic allocation of original and shadow data sets” on page 107](#)
- [“Restrictions on data set names” on page 107](#)
- [“Data sets after reorganization” on page 107](#)

### Database, primary index, and ILDS

For all database data sets, regardless of the NAMESWAP option, the *original\_dbds* DD names defined by the DBD are used to specify the original (disorganized) input data sets. The shadow DD names defined by DDNMAP control statements are used to specify the shadow (reorganized) data sets.

An HDAM database requires at least two unique DD names and two unique data set names: that is, a DD name and a data set name are required for each data set group for input and shadow database.

A HIDAM database requires at least four DD names and four data set names: that is, a DD name and a data set name are required for primary index and each data set group for input and shadow database.

---

<sup>1</sup> The term *shadow data sets* means the data sets in which the Reload task loads segments or the index builder loads index records.

<sup>2</sup> In this information, the term *output data sets* means the database data sets or index data sets that are generated as a result of reorganization.



A HISAM database requires at least four DD names and four data set names: that is, the primary data sets for input and shadow databases require a DD name and a data set name, and so do the overflow data sets for input and shadow databases.

A SHISAM database and root-only HISAM require at least two DD names and two data set names: that is, the primary data sets for input and shadow databases require a DD name and a data set name.

If the database contains multiple data set groups, each data set group requires two pairs of DD names and data set names, one for the input and the other for the shadow.

A PHDAM database requires at least three unique DD names and three unique data set names for each partition to be reorganized: that is, for each input and shadow partition, a DD name and a data set name are required for each data set group; and for each input partition, a DD name and a data set name are required for the indirect list data set (ILDS).

A PHIDAM database requires at least four DD names and four data set names for each partition to be reorganized: that is, for the primary index and each data set group, a DD name and a data set name are required for each input and shadow partition.

If a logical parent of a unidirectional logical relationship, a bidirectional logical relationship, or a partitioned secondary index is defined for the database, a DD name and a data set name are required for the shadow ILDS. To process ILDS properly, either of the following conditions must be met:

- Dynamic allocation of shadow data sets is designated and all shadow ILDS exist.
- The shadow ILDS of all partitions that are to be reorganized are specified in the JCL stream.

If either of the conditions is met and also if ILDSBLD=YES is specified, the Smart Reorg utility always initializes the shadow ILDS. Furthermore, if NAMESWAP=YES is specified, the Smart Reorg utility does name swapping between the original ILDS and the shadow ILDS.

If multiple data set groups are defined for PHDAM or PHIDAM, each data set group of each partition needs two pairs of DD names and data set names, one for the input and the other for the shadow.

By default, the original database data sets and the shadow database data sets are allocated dynamically. For details, see [“Dynamic allocation of original and shadow data sets” on page 107](#). For how the DD names for shadow data sets are determined, see [“DDNMAP control statement” on page 133](#).

IBM recommends that you have IMS Database Reorganization Expert allocate input and shadow database data sets dynamically. Original data sets of HALDB partitions are always allocated dynamically.

For how the DD names of shadow data sets for non-HALDB are determined, see [“DDNMAP control statement” on page 133](#). The following table shows how the DD names of shadow data sets for a HALDB partition are determined. Note that for an online reorganization capable HALDB partition, the shadow DD names are determined by whichever the data sets are active.

*Table 12. DD name suffixes of shadow data sets for a HALDB partition*

Data set type	DD name suffix for the data set			
	When A-J and X side is active		When M-V and Y side is active	
	Original data set	Shadow data set	Original data set	Shadow data set
DSG A	A	M	M	A
DSG B	B	N	N	B
DSG C	C	O	O	C
DSG D	D	P	P	D
DSG E	E	Q	Q	E
DSG F	F	R	R	F
DSG G	G	S	S	G

Table 12. DD name suffixes of shadow data sets for a HALDB partition (continued)

Data set type	DD name suffix for the data set			
	When A-J and X side is active		When M-V and Y side is active	
	Original data set	Shadow data set	Original data set	Shadow data set
DSG H	H	T	T	H
DSG I	I	U	U	I
DSG J	J	V	V	J
ILDS	L	Z	L	Z
PINDEX	X	Y	Y	X

**Note:** DSG denotes the data set group, ILDS is the indirect list data set, and PINDEX is the primary index.

## Secondary indexes

Secondary indexes can be created during parallel reorganization of a database by specifying INDEXBLD=YES or PSINDEXBLD=YES.

If INDEXBLD=YES or PSINDEXBLD=YES is specified, the secondary index data sets are allocated dynamically by default. If DYNALLOC=(xxx,xxx,NO) is specified, you must code the DD statements for the secondary indexes in the job step. Use the DD names that are defined in the DBD. The secondary index data sets must be reusable or empty.

The data set names to be specified for the DD names depend on the DBSHARE option:

- If you specify DBSHARE=YES, specify new names other than the current (original) names that are already registered to DBRC. In this case, you must specify INDEXBLD=YES,NEW.
- If you specify DBSHARE=NO, specify either the new names or the current names. If you want to rebuild secondary indexes in new data sets, specify INDEXBLD=YES,NEW; if you want to rebuild in the current data sets, specify INDEXBLD=YES,CURRENT.

If you specify NAMESWAP=YES and INDEXBLD=YES,NEW, the data set names are swapped after rebuilding the secondary indexes; that is, the output secondary indexes are renamed to the original names and the original secondary indexes are renamed to temporary names. If the original data set does not exist, only the cluster names are renamed but the component names are not renamed. Regardless of whether the component names are renamed, you can get access to the database. If you need to rename the component names, see [“Performing manual name swapping” on page 212](#).

If you have deleted an original secondary index database data set before running IMS Database Reorganization Expert, IBM recommends that you reallocate the original secondary index database data set, and run IMS Database Reorganization Expert with INDEXBLD=YES,CURRENT. Name swapping is not needed for secondary indexes. In that case, if you want to cancel the reorganization processing, you must either build these secondary indexes or recover them for fallback of the database into the prereorganization status.

If you specify to allocate secondary index data sets dynamically, new data set names are determined automatically from the data set names defined in the DFSMDA members. For PSINDEXes, the data set names that are defined in the RECON data sets are used. For more information, see [“Dynamic allocation of original and shadow data sets” on page 107](#) and [“DYNALLOC control statement” on page 136](#).

IBM recommends specifying that the data sets for secondary indexes be allocated dynamically.

## Dynamic allocation of original and shadow data sets

The way in which original and shadow data sets for database and indexes are allocated is determined by the DYNALLOC control statement. The DASD space for shadow data sets is allocated by the SPACEALLOC control statement.

By default, the original database data sets of HISAM, SHISAM, HDAM, or HIDAM are allocated by using DFSMDA members. If DBRC is active, all databases including the primary index and the secondary indexes must be registered in RECON unless you disable the DYNALLOC option. If DBRC is active and DYNALLOC=(YES,xxx,xxx) is specified, the integrity of the data set names defined in DFSMDA members and those registered in DBRC is checked before the reorganization starts.

For a HALDB, the data sets of PHDAM or PHIDAM partition are always allocated dynamically by using RECON registration, not before the reorganization starts, but when the partition is first accessed.

By default, shadow data sets are allocated dynamically. For a non-partitioned database, the names of the shadow data sets are determined automatically. The shadow name consists of the name of the corresponding original input data set followed by a suffix (the default is .Z). For example, suppose your original data set is named IMS.TESTDB01. By default, the shadow data set is named IMS.TESTDB01.Z. If you specify DYNALLOC=,A, the shadow data set is named IMS.TESTDB01.A. You can specify any alphabetic character except T as the suffix. The same rule also applies to the shadow primary index of HIDAM database, shadow secondary index, and shadow indirect list data set of PHDAM or PHIDAM.

If the A-through-J and X data sets of PHDAM or PHIDAM partition are active, the same naming rule as the one applied to non-partitioned database is applied. If the M-through-V and Y data sets of PHDAM or PHIDAM partition are active, the shadow data set name for the partition is determined by the names of A-through-J and X data sets. For example, if your original data set name of DSG A is IMS.TESTDB01.M0001, the default shadow data set name is IMS.TESTDB01.A0001.Z (the corresponding A-side data set name IMS.TESTDB01.A0001 suffixed with .Z). And, by the name swapping process, the shadow data set is renamed to the A-side data set name IMS.TESTDB01.A0001. The original data set IMS.TESTDB01.M0001 is not renamed but remain as it is.

If both SPACALLOC=YES and the DDFPDS2 DD statement are specified, this naming convention for shadow data sets does not apply. The names of shadow data sets are determined from the information defined in the DDFPDS2 data set. For details, see [“SPACEALLOC control statement” on page 156](#).

For details about dynamic allocation of original and shadow data sets, see [“DYNALLOC control statement” on page 136](#) and [“SPACEALLOC control statement” on page 156](#). For details about data set name swapping, see [“NAMESWAP control statement” on page 147](#).

**Note:** For VSAM data sets, .Z is not required for component names but it is required for the cluster name.

## Restrictions on data set names

If you enable dynamic allocation or NAMESWAP=YES, the name of each original data set must contain 42 or fewer characters. For a VSAM data set, this restriction applies to both the cluster name and its component names. It is the user's responsibility to make sure that any data set name created by Reorganization Manager, when dynamic allocation is used or NAMESWAP=YES is specified, does not conflict with any existing data set name or cluster name.

## Data sets after reorganization

If you specify NAMESWAP=YES, the names of the primary database and primary index data sets and the names of shadow ones are swapped. The secondary index databases are swapped only if the IMS Index Builder task is activated and the data set specified for the DD name of the secondary index is different from what is registered to DBRC.

For a non-partitioned database and PHDAM and PHIDAM partition whose A-through-J and X data sets are active, each original data set name, including the VSAM component name, is renamed to the original name plus suffix .T. For details about the name swapping process, see [“NAMESWAP control statement” on page 147](#).

For PHDAM and PHIDAM partitions whose M-through-V and Y data sets are active, the original data sets are not renamed and remain as they are. In this case, shadow data sets are renamed to A-through-J and X data set names. If A-through-J and X data sets exist, shadow data sets are swapped with A-through-J and X data sets.

Renamed original data sets can be deleted or renamed to shadow data set names. For more information, see [“DISPOLDDS control statement”](#) on page 135.

In case name swapping fails, if you had specified NAMESWAPFAIL=BACKOUT, the data set names are restored to the names the data set had when the name swapping process started. For details, see [“NAMESWAPFAIL control statement”](#) on page 148.

You can see how the data sets were renamed by the Smart Reorg utility by checking the Result of Name Swapping report. See [“Result of Name Swapping report”](#) on page 263.

## Considerations for DBD libraries

---

You can change DBDs during parallel reorganization by coding control statement NEWDBD=*new\_dbdlib*, which specifies the DD name of the library that contains the new DBD definition that the Reload task and the Index Builder task use.

The library defined by the IMS DD statement contains the original definition that the Unload task uses. For more information about DBD change, see [“NEWDBD control statement”](#) on page 149.

## Considerations for secondary indexes

---

You might need to rebuild secondary indexes during the reorganization process.

When you reorganize a non-HALDB, you must rebuild its secondary indexes.

- If you specify the INDEXBLD=YES option, the Index Builder task rebuilds each secondary index in the Smart Reorg utility job.
- If you specify the INDEXBLD=NO option, secondary indexes are not rebuilt in the job. You must rebuild the secondary indexes by using an index building utility, such as IMS Index Builder, in a separate job step.

Reorganization of a HALDB does not require rebuilding each partitioned secondary index (PSINDEX) because the HALDB self-healing pointer process corrects the secondary index pointers by using the ILDS that is rebuilt or updated during the reorganization. However, if you want to avoid activating the process while application programs are running, you can specify one of the following three methods to rebuild each PSINDEX:

### **Specifying the PSINDEXBLD=YES option in the (REORG) block**

The Index Builder task is activated to rebuild each PSINDEX. With this method, you cannot specify the PARTITION control statement so all the partitions of the HALDB are reorganized in a single Smart Reorg job. For more information, see [“PSINDEXBLD control statement”](#) on page 153.

### **Specifying the WPHLQ control statement in the (RELOAD) block**

For each HALDB partition, an HPSRWFP work file is generated in the Reload task.

You can specify the PARTITION control statement with this method. However, all the partitions of the HALDB must be reorganized in one or more Smart Reorg jobs so that HPSRWFP work files are created for all partitions. Then, supply the HPSRWFP work files as input to the IMS Index Builder job with the INPUT HPSRWFP control statement. For more information, see [“WPHLQ control statement”](#) on page 534.

### **Not specifying the PSINDEXBLD=YES option or the WPHLQ control statement**

After running one or more Smart Reorg jobs to reorganize specific partitions or all the partitions, run the IMS Index Builder job with the INPUT IBSCAN control statement. In the IMS Index Builder job, all the HALDB partitions are scanned.

## Considerations for logical relationships

---

Considerations for parallel reorganization processing for HDAM, HIDAM, and HISAM that have logical relationships are covered in this topic.

If the database to be reorganized is a non-HALDB that has logical relationships, you must code the DFSURCDS DD statement, which defines the control data set that contains the data that is generated by IMS Database Prereorganization utility (DFSURPRO). This data set is not required for HALDB even if it has a logical relationship or a (partitioned) secondary index.

Subsections:

- [“Internal logical relationships of HDAM and HIDAM” on page 109](#)
- [“External logical relationships of HDAM and HIDAM” on page 109](#)
- [“Logical relationship of HISAM” on page 110](#)
- [“Logical relationships that do not require Prefix Resolution and Update” on page 110](#)

### Internal logical relationships of HDAM and HIDAM

If the database is either an HDAM or a HIDAM and it has only internal logical relationships, you can specify both IC=YES and PREFIXRES=YES in the (REORG) block. If both IC=YES and PREFIXRES=YES are specified, only Type-B Image Copy (ICTYPE=B) is supported for image copy processing. If the database has external logical relationships, PREFIXRES=YES is ignored and no prefix resolution or update processing is done in the Smart Reorg job step. For details about processing such a database, see [“External logical relationships of HDAM and HIDAM” on page 109](#) and [“Post-reorganization processing for database with logical relationships” on page 214](#).

If the database also has a secondary index and you specify PREFIXRES=YES and INDEXBLD=NO, it is recommended that you code the HPSRSIDX DD statement in the Smart Reorg JCL stream. The Reload task creates secondary index maintenance records in the HPSRSIDX data set. The data set is used as an input to utilities to resolve secondary index relationships or as an input to IMS Index Builder. Logical relationship maintenance records that the Reload task generates are processed by the Prefix Resolution task to update affected segment prefixes.

If you specify PREFIXRES=YES and INDEXBLD=YES, you do not need to code the HPSRSIDX DD statement. In this case, logical relationship maintenance records are processed by the Prefix Resolution task, and secondary index maintenance records are processed by the Index Builder task.

Regardless of the value specified for the INDEXBLD control statement, you can generate image copies of the reorganized database data sets by specifying IC=YES and ICTYPE=B. For details about Type-B Image Copy, see [“Type-B Image Copy processing” on page 111](#).

### External logical relationships of HDAM and HIDAM

If the database is an HDAM or a HIDAM database and has external logical relationships, the prefix resolution and update process must be performed outside the Smart Reorg job step. To do so, you can use the Pre-reorganization utility and the Post-reorganization utility. For more information, see [Chapter 14, “Pre-reorganization utility and Post-reorganization utility,” on page 287](#).

If you run the Smart Reorg utility by itself (without the Pre-reorganization utility or the Post-reorganization utility), you cannot specify IC=YES and PREFIXRES=YES. In this case, you must code the DFSURWF1 DD statement in your Smart Reorg JCL stream. Image copies, if necessary, must be taken after the segment prefixes are updated by using the IMS Prefix Resolution and Prefix Update utilities or the compatible utilities that are run outside the Smart Reorg job step. For details, see [“Post-reorganization processing for database with logical relationships” on page 214](#).

For logical relationships that use only symbolic pointers, see [“Logical relationships that do not require Prefix Resolution and Update” on page 110](#).

If the database also has a secondary index and you specify INDEXBLD=NO, it is recommended that you code the HPSRSIDX DD statement in the Smart Reorg JCL stream. The Reload task creates secondary

index maintenance records in the HPSRSIDX data set. The data set is used as an input to utilities to resolve secondary index relationships or as an input to IMS Index Builder. If the HPSRSIDX DD statement is coded, the DFSURWF1 data set contains only logical relationship maintenance records that are produced by the Reload task. By coding both DFSURWF1 and the HPSRSIDX DD statements, you can reduce the number of records to be sorted by the Prefix Resolution job and IMS Index Builder job that follow.

If the HPSRSIDX DD statement is not coded, the DFSURWF1 data set contains both secondary index maintenance records and logical relationship maintenance records. You can process the DFSURWF1 data set normally in the Prefix Resolution job that follows.

If you specify INDEXBLD=YES, the secondary index maintenance records are written neither to the DFSURWF1 data set nor to the HPSRSIDX data set, and the DFSURWF1 data set contains only logical relationship maintenance records.

## Logical relationship of HISAM

If the database is a HISAM database and has either internal or external logical relationships, PREFIXRES=YES cannot be specified because IMS HP Prefix Resolution does not support such a database. The same guideline that is explained in [“External logical relationships of HDAM and HIDAM” on page 109](#) applies to such a database.

## Logical relationships that do not require Prefix Resolution and Update

For the following databases with logical relationships, you can specify IC=YES and either ICTYPE=A or B to take image copies because the prefix resolution and update utilities are not needed:

- The logical parent database for which DBIL is not specified in the Pre-reorganization utility.
- The logical child database that contains no direct logical pointers. Only symbolic pointers are used.

## Considerations for Image Copy processing

---

Image Copy processing, Type-A or Type-B, can be activated by coding IC=YES in the (REORG) block of the HPSIN data set.

Image Copy processing that is supported by the Smart Reorg utility is explained in [“Image Copy processing and HASH pointer checking” on page 74](#).

An appropriate processing type is selected by the Smart Reorg utility depending on the database organization. However, you can override it by specifying the ICTYPE control statement. For details, see [“IC control statement” on page 138](#) and [“ICTYPE control statement” on page 139](#).

You can also specify the control statements for IMS HP Image Copy in ICEIN DD. For more information, see [“Control statements for the Image Copy task” on page 177](#).

For restrictions that apply to Image Copy processing, see [“Smart Reorg restrictions and requirements” on page 58](#).

**Note:** For HALDB ILDSs and PHIDAM primary index, image copies are not taken in either Type-A or Type-B Image Copy. In recovering HALDB, ILDSs and the PHIDAM primary index are rebuilt by using the HALDB Index/ILDS Rebuild utility (DFSPREC0) and, therefore, image copies of these data sets are not used.

Subsections:

- [“Type-A Image Copy processing” on page 111](#)
- [“Type-B Image Copy processing” on page 111](#)
- [“Types of Image Copy processing when CRIC=ALWAYS” on page 111](#)
- [“Image Copy and DBRC” on page 112](#)
- [“Image Copy and timestamps” on page 112](#)



## Type-A Image Copy processing

The flow of Type-A Image Copy processing is shown in [“Data and process flow of Type-A Image Copy”](#) on page 79.

Type-A Image Copy processing applies to reorganization of the following database organizations:

- HDAM, HIDAM, and HISAM that do not need Prefix Resolution and Update for logical relationships
- SHISAM
- PHDAM and PHIDAM:
  - Single partition
  - Selected consecutive partitions
  - Entire database

PHDAM and PHIDAM databases can have any type of logical relationship.

### Notes:

- Image copy stacking is not supported. To enable image copy stacking, use Type-B Image Copy.
- DD statements for image copy data sets of secondary index of HDAM, HIDAM, or HISAM cannot be specified. Always use dynamic allocation.

## Type-B Image Copy processing

The flow of Type-B Image Copy processing is shown in [“Data and process flow of Type-B Image Copy with Prefix Resolution/Update”](#) on page 80.

Type-B Image Copy processing applies to HDAM and HIDAM that have internal logical relationships. Image copies are taken after the Prefix Resolution and Update processes are completed. For details, see [“Internal logical relationships of HDAM and HIDAM”](#) on page 109.

When ICTYPE=B is coded explicitly, the following database organizations are also supported:

- HDAM, HIDAM, and HISAM that have no logical relationship
- PHDAM and PHIDAM that have no logical relationship
- PHDAM and PHIDAM that have one or more logical relationships

Only Type-B Image Copy supports image copy stacking.

**Note:** For information about database organizations that are not supported, see [“Smart Reorg restrictions and requirements”](#) on page 58.

## Types of Image Copy processing when CRIC=ALWAYS

When CRIC=ALWAYS is specified, the type of Image Copy processing is determined based on the result of database evaluation performed by the CRSS.

- If the CRSS determines that the entire database needs to be reorganized, all image copies are created with the image copy type that the ICTYPE control statement specifies.
- If the CRSS determines that the database does not need to be reorganized, ICTYPE control statement is ignored and Type-B Image Copy processing is applied. All image copies are created from original database data sets.
- If the CRSS determines that only some HALDB partitions need to be reorganized, ICTYPE control statement is ignored and Type-B Image Copy processing is applied. Image copies of reorganized partitions are created from shadow database data sets, and image copies of other (not reorganized) partitions are created from original database data sets.

See also [“Data and process flow of conditional reorganization and image copy for HALDB”](#) on page 82.

## Image Copy and DBRC

If IC=YES and NAMESWAP=YES are specified, the ICNEEDED control statement is ignored, and the DBRC notification processing is done by the combination of the following information:

- How the database or index is registered to DBRC.
- How the HDPC parameter is specified in the ICEIN data set.
- How the VIC parameter is specified in the ICEIN data set.

If IC=YES is specified, image copy data sets of primary DSGs are always created. If DBRC is active and NAMESWAP=YES is specified, the reorganization is always notified to DBRC, and whether the database is registered as RECOVABL or NONRECOV, image copy data sets are always registered with NOTIFY.IC commands.

For HIDAM primary index and secondary indexes of HDAM and HIDAM databases, the image copy process depends on the combination of the following definitions:

- HDPC=Y or O
- VIC=N or Y
- RECOVABL or NONRECOV in DBRC database registration
- ICREQ or NOICREQ (for the database registered to DBRC as NONRECOV)

The system default for the HDPC and VIC parameters under the Smart Reorg utility are HDPC=Y and VIC=N. For details about the HDPC parameter under the Smart Reorg utility, see [“Considerations for HASH pointer checking”](#) on page 114. For details about the VIC parameter, see the *IMS High Performance Image Copy User's Guide*.

Recommended combinations are:

- If you want image copies of indexes, register the indexes to DBRC as RECOVABL and accept the system defaults for HDPC and VIC parameters.
- If you do not need image copies of the index, register the index to DBRC as NONRECOV and NOICREQ, and specify HDPC=O and VIC=N on the GLOBAL statement or the IC statement for the index. In this case, the DBRC REORG record is created without turning on the IC NEEDED flag, but neither IC nor UIC (user image copy) record is created for the index. You can reduce the number of unnecessary UIC records in RECON data sets.
- If you do not need image copies of the index but want a UIC record, register the index to DBRC as NONRECOV and NOICREQ, and specify HDPC=Y, VIC=Y, and the VICNAME parameter on the GLOBAL statement or the IC statement for the index. Then, the DBRC REORG record without the IC NEEDED flag turned on and UIC record with the user data supplied by VICNAME are created for the index.

## Image Copy and timestamps

The DBRC REORG and IC timestamps that are used by the Smart Reorg utility are different from those timestamps that you see when you use the standard IMS reorganization utilities.

The following figures show the timing at which each timestamp is taken in each Image Copy processing type.

In Type-A Image Copy, as shown in [Figure 13](#) on page 113, the REORG timestamp is taken after the database is made read-only or stopped, and just before the reorganization is started. The IC timestamp is taken about 3 seconds after the REORG timestamp is taken. Note that Type-A Image Copy process is started at the same time that the reorganization process is started.



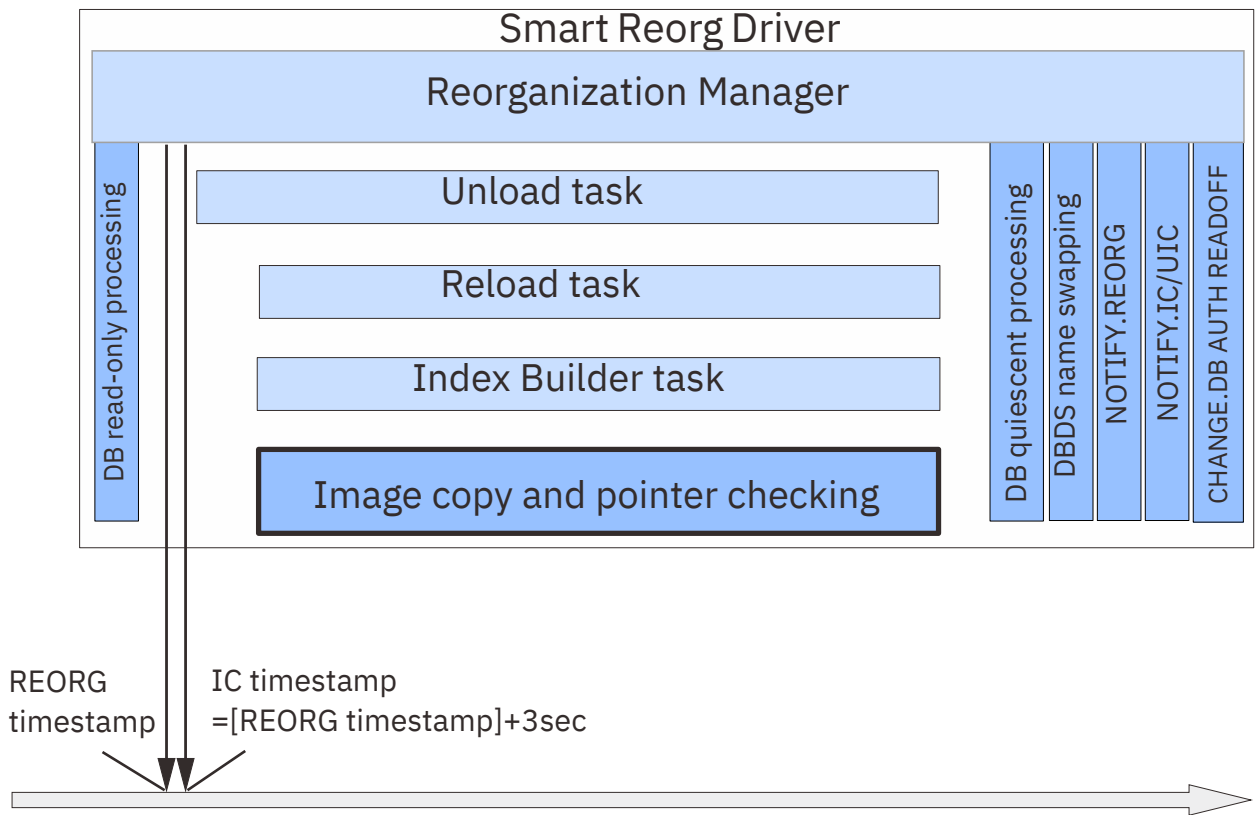

Figure 13. Type-A Image Copy and REORG/IC timestamps

In Type-B Image Copy, as shown in the following figure, the REORG timestamp is taken just before the Type-B image copy processing is started, and the IC timestamp is taken about 3 seconds after the REORG timestamp is taken, which is just before the image copy processing is started.

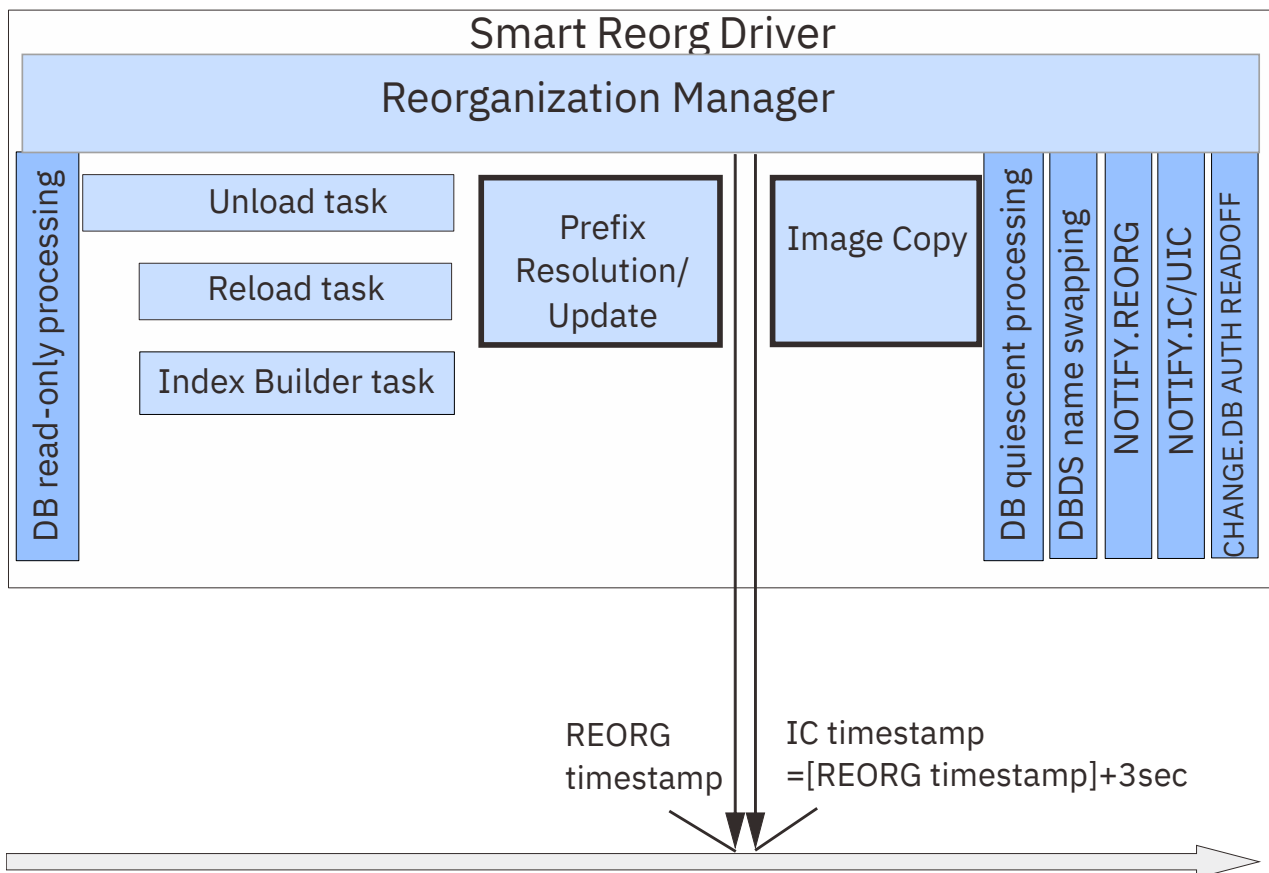

Figure 14. Type-B Image Copy and REORG/IC timestamps

**Note:** In both Type-A and Type-B Image Copy processing, the timestamps that are used in the RUNTIME parameter for NOTIFY.REORG, NOTIFY.IC, and NOTIFY.UIC commands are in local time and in punctuated format. For details about the standard timestamp format, see the topic "DBRC time stamps" in *IMS Commands*.

## Considerations for HASH pointer checking

HASH pointer check for the reorganized database and indexes is activated by the HDPC=Y parameter, which is one of the parameters supported by IMS HP Image Copy.

The HDPC parameter can be specified on the GLOBAL, the IC, or the AIC control statement in the ICEIN data set. HDPC=Y on the GLOBAL control statement applies to all data sets including indexes. HDPC=Y on the IC or the AIC control statement applies to the data set that is identified by that control statement.

If you specify IC=YES in the (REORG) block of the HPSIN data set, HDPC=Y on the GLOBAL control statement is used as the system default and HASH pointer checking is invoked. If an appropriate version of IMS HP Pointer Checker is not installed, the HDPC=Y parameter is ignored. See ["Software prerequisites"](#) on page 39 for supported versions of IMS HP Pointer Checker.

You can also specify HDPC=O instead of HDPC=Y, if you want to run HASH pointer checking only against indexes without creating image copy data sets of the indexes.

You can control the report output by specifying suboptions in the HDPC parameter. For details, see ["Reports produced by IMS HP Pointer Checker"](#) on page 282. For details about the HDPC parameters, see the *IMS High Performance Image Copy User's Guide*.

**Note:** The following IMS HP Pointer Checker messages are suppressed when HASH pointer check is done in a Smart Reorg utility job: FABP1370I, FABP1380I, FABP1410I, FABP1420I, FABP1440I, FABP1450I, and FABP4011I.

## Considerations for the IMS management of ACBs

---

If the IMS management of ACBs is enabled, the Smart Reorg utility can refer to database definitions in the IMS catalog directory instead of the DBD library.

IMS catalog definition is retrieved from either:

- The IMS Catalog Definition exit routine (DFS3CDX0) in the STEPLIB concatenation.
- The DFSDFxxx PROCLIB member specified by EXEC parameter DFSDF=xxx and the PROCLIB DD statement.

The following conditions must be satisfied to use IMS-managed ACBs:

- The IMS catalog database is registered to RECON data sets.
- The name of the IMS catalog database is defined in the RECON record with the following DBRC command: `CHANGE RECON CATALOG(name)`
- If the DFSMDA member with the `TYPE=CATDShLQ` statement is used to specify the high-level qualifier of IMS catalog system data sets, the library that contains the DFSMDA member must be in the STEPLIB concatenation of the Smart Reorg job.

The following options can be used when reorganizing a database by using pending database definitions in the IMS catalog staging data sets:

- If you want to run the unload process within the Smart Reorg job step, specify `NEWDBD=*STAGING` in the (REORG) block of the HPSIN data set. The DFSACBPD DD statement is not needed.
- If you want to run the unload process in a separate job step, specify `REORGINPUT=ULDS` and the DFSACBPD DD statement with the STAGING keyword.

For more information, see [“NEWDBD control statement” on page 149](#) and [“Example 15: Reorganizing a database when the IMS management of ACBs is enabled” on page 201](#).



## Chapter 9. Smart Reorg control statements

Control statements for the Smart Reorg utility are specified in the HPSIN data set and the ICEIN data set.

Control statements that are specified in the HPSIN data set are divided into the following blocks. You must specify the control statement blocks in the following order. Otherwise, the job ends with errors.

### **(REORG) block**

The control statements for the Smart Reorg Driver are specified in this block.

### **(CONDREORG) block**

The control statements for the Conditional Reorganization Support Service are specified in this block.

### **(UNLOAD) block**

The control statements for the Unload task are specified in this block.

### **(RELOAD) block**

The control statements for the Reload task are specified in this block.

### **(INDEXBLD) block**

The control statements for the Index Builder task are specified in this block.

### **(PREFIXRES) block**

The control statements for the Prefix Resolution task are specified in this block.

Each block of control statement starts with a block identifier, which is the name of the block in parentheses starting in column 1. The control statement blocks must be specified in this format as in the following example:

```
//HPSIN DD *
(REORG)
... Control statements for Reorganization Manager ...
(CONDREORG)
... Control statements for Conditional Reorganization Support Service ...
(UNLOAD)
... Control statements for the Unload task ...
(RELOAD)
... Control statements for the Reload task ...
(INDEXBLD)
... Control statements for the Index Builder task ...
(PREFIXRES)
... Control statements for the Prefix Resolution task ...
/*
```

All control statement blocks are optional. You must code appropriate control statement in the (REORG) block to use the following control statement blocks:

- To enable the (CONDREORG) block, code CONDREORG=YES, CONDREORG=YES,REORGDIAG, or CONDREORG=YES,DIAGONLY in the (REORG) block.
- To enable the (INDEXBLD) block, code INDEXBLD=YES or PSINDEXBLD=YES in the (REORG) block.
- To enable the (PREFIXRES) block, code PREFIXRES=YES in the (REORG) block.

Control statements in each block must conform to the syntax rules of the Smart Reorg utility.

Control statements for Image Copy processing and HASH pointer checking are specified in ICEIN DD. The syntax must follow the syntax rules of IMS HP Image Copy. For more information about ICEIN control statement syntax, see the *IMS High Performance Image Copy User's Guide*.

**Tip:** Some control statements can be used to improve the performance of Smart Reorg utility jobs. See [“Performance tips for the Smart Reorg utility” on page 609](#) to learn the techniques.

### **Topics:**

- [“Control statement syntax for the HPSIN data set” on page 118](#)
- [“Control statements for the Smart Reorg Driver” on page 118](#)
- [“Control statements for the Conditional Reorganization Support Service” on page 162](#)

- [“Control statements for the Unload task” on page 167](#)
- [“Control statements for the Reload task” on page 170](#)
- [“Control statements for the Index Builder task” on page 175](#)
- [“Control statements for the Prefix Resolution task” on page 176](#)
- [“Control statements for the Image Copy task” on page 177](#)
- [“Hints and tips for specifying control statements” on page 178](#)

## Control statement syntax for the HPSIN data set

Control statements in each block in the HPSIN data set must conform to the following syntax:

- A control statement is a keyword followed by an equal sign and a value or values.
- A keyword and its value or values must be on a single line and must be specified between columns 1 and 80, both inclusive.
- For each control statement, any number of leading blanks can be specified for the purpose of indentation.
- A statement keyword must be separated from its associated value by an equal sign (=). The equal sign must not be preceded by blanks, and not be followed by blanks.
- A line that starts with an asterisk (\*) in column 1 is treated as a comment line.
- You can specify Y for YES and N for NO.

## Control statements for the Smart Reorg Driver

The control statement block for the Smart Reorg Driver contains user specifications for controlling the processes of the Smart Reorg Driver and the Parallel Reorganization Service.

The control statement block for the Smart Reorg Driver starts with a line that specifies the block name (REORG). The control statements for the (REORG) block are categorized as follows:

- [“Conditional reorganization” on page 118](#)
- [“Integration with IMS Tools Base” on page 120](#)
- [“Reorganization process control” on page 121](#)
- [“HALDB reorganization” on page 122](#)
- [“Input and output database data sets” on page 123](#)
- [“Database access and state” on page 124](#)
- [“Reports” on page 125](#)
- [“IPRPIPE” on page 126](#)
- [“Error handling” on page 126](#)

### Conditional reorganization

Use the following control statement keywords to enable and control conditional reorganization.

*Table 13. Control statements for conditional reorganization*

Keyword	Acceptable values	Default	Description
CONDREORG	YES YES,REORGDIAG YES,DIAGONLY NO	NO	Specifies whether to enable the Conditional Reorganization Support Service. See <a href="#">“CONDREORG control statement” on page 128</a> .

Table 13. Control statements for conditional reorganization (continued)

Keyword	Acceptable values	Default	Description
CRIC	COND ALWAYS	None	Specifies to create image copies of all database data sets or HALDB partitions even when the Conditional Reorganization Support Service (CRSS) determines that reorganization of the entire database or some partitions are not needed. See <a href="#">“CRIC control statement”</a> on page 130.
CRUNLOAD	COND ALWAYS	None	Specifies to create an unload data set that contains data from the database or HALDB partitions. You can choose to create an unload data set only when the Conditional Reorganization Support Service (CRSS) determines that reorganization is needed or every time the job is run (regardless of whether reorganization is needed). See <a href="#">“CRUNLOAD control statement”</a> on page 130.
KEYLABELCHK	YES YES,PREFIX YES,FULLNAME NO	NO	Specifies to check the integrity of the key labels that are assigned to the database data sets. If the key labels are different from those defined in the RACF data set profile or the SMS data class, the Conditional Reorganization Support Service determines that the database requires reorganization. See <a href="#">“KEYLABELCHK control statement”</a> on page 145.
RC_CHANGE	NONE (event_name,n) n=1 - 99	NONE	Specifies the return code that the Smart Reorg utility returns when a specific event is detected by the Conditional Reorganization Support Service. See <a href="#">“RC_CHANGE control statement”</a> on page 154.

## Integration with IMS Tools Base

Use the following control statement keywords to enable the features provided by IMS Tools Base.

Table 14. Control statements for IMS Tools Base integration

Keyword	Acceptable values	Default	Description
ADDBGRP	<i>dbgrpname</i> or *NO	*NO	Specifies the database group name defined to Autonomics Director. See “ADDBGRP control statement” on page 127.
ADXCFGRP	<i>xcfgrpname</i> or *NO	*NO	Specifies the XCF group name of the Autonomics Director server. See “ADXCFGRP control statement” on page 127.
ITKBDATA	UTILHIST or *NO	*NO	Specifies the type of additional data to store in the IMS Tools KB repository. See “ITKBDATA control statement” on page 143.
ITKBLOAD	<i>libname</i> or *NO	*NO	Specifies the library name of IMS Tools KB. See “ITKBLOAD control statement” on page 144.
ITKBSRVR	<i>servername</i> <i>servername,ERRC04</i> *NO	*NO	Specifies the name of the IMS Tools KB server XCF group. See “ITKBSRVR control statement” on page 144.
TOSITEST	( <i>max,interval</i> )	(1,1)	Specifies the maximum number of attempts and the interval time for Reorganization Manager to verify whether the database is being used. See “TOSITEST control statement” on page 160.
TOSIWAIT	0 - 9999	300	Specifies the IMS Tools Online System Interface response timeout value in seconds. See “TOSIWAIT control statement” on page 160.
TOSIXCFGRP	<i>grpname</i>	None	Specifies the XCF group name that IMS Tools Online System Interface uses. See “TOSIXCFGRP control statement” on page 161.



Table 14. Control statements for IMS Tools Base integration (continued)

Keyword	Acceptable values	Default	Description
ZIIPMODE	COND or NEVER	NEVER	Specifies whether to offload eligible workloads to zIIP processors. See “ZIIPMODE control statement” on page 162.

## Reorganization process control

Use the following control statement keywords to control the reorganization process.

Table 15. Control statements for reorganization process control

Keyword	Acceptable values	Default	Description
DALUNIT	<i>group_name</i> or <i>device_type</i>	SYSALLDA	Specifies the device on which dynamic allocation allocates temporary data sets. You can specify a group name or device type. See “DALUNIT control statement” on page 131.
HPIO	YES or NO	None	Specifies whether to use the High Performance I/O Driver in all subtasks that support it. See “HPIO control statement” on page 137.
IC	YES or NO	NO	Specifies whether to generate image copies of the reorganized database. See “IC control statement” on page 138.
ICTYPE	A or B	A	Specifies the type of Image Copy processing. See “ICTYPE control statement” on page 139.
INDEXBLD	NO YES,CURRENT YES,NEW	NO	Specifies whether to rebuild all secondary indexes for the database in the Smart Reorg utility job step. See “INDEXBLD control statement” on page 143.
NEWDBD	<i>ddname</i>	None	Specifies the DD name for the new DBD library. Use this control statement keyword if you want to change the DBD during reorganization. See “NEWDBD control statement” on page 149.

Table 15. Control statements for reorganization process control (continued)

Keyword	Acceptable values	Default	Description
PREFIXRES	YES or NO	NO	Specifies whether to do prefix resolution and prefix update to resolve internal logical relationships of non-HALDB database. See <a href="#">“PREFIXRES control statement”</a> on page 153.
REORGINPUT	DBDS or ULDS	DBDS	Specifies the type of input data sets for reorganization processing. You can request the utility to unload data from input database data sets or supply unloaded data sets. See <a href="#">“REORGINPUT control statement”</a> on page 155.
UNLOADONLY	YES or NO	NO	Specifies to run only the Unload task to create an unload data set without reorganizing the database. See <a href="#">“UNLOADONLY control statement”</a> on page 161.

## HALDB reorganization

Use the following additional control statement keywords when you reorganize a HALDB.

Table 16. Control statements for HALDB reorganization

Keyword	Acceptable values	Default	Description
ILDSBLD	YES,COND YES,DSPR YES,INITONLY NO	YES,COND	Specifies whether to build Indirect List data sets (ILDSS) during reorganization. See <a href="#">“ILDSBLD control statement”</a> on page 139.
PARTITION	( <i>partname,num</i> ) or *ALL	*ALL	Specifies the HALDB partitions to reorganize. See <a href="#">“PARTITION control statement”</a> on page 150.
PSINDEXBLD	NO YES,CURRENT YES,NEW	NO	Specifies whether to rebuild all partitioned secondary indexes for the database in the Smart Reorg utility job step. See <a href="#">“PSINDEXBLD control statement”</a> on page 153.

## Input and output database data sets

Use the following control statement keywords to control input and output for database data sets; DASD space allocation for shadow data sets, dynamic allocation, name swapping, and so on.

Table 17. Control statements for database data sets

Keyword	Acceptable values	Default	Description
DDNMAP	( <i>original_dd,shadow_dd</i> )	(%%%-----, TMP-----)	Specifies DD names for shadow data sets. See “ <a href="#">DDNMAP control statement</a> ” on page 133.
DELOLDDS	YES or NO	NO	Specifies to delete original input database data sets after successful reorganization. See “ <a href="#">DELOLDDS control statement</a> ” on page 135.
DISPOLDDS	DELETE NEWSHADOW TEMPNAME	TEMPNAME	Specifies the disposition of original input database data sets after successful reorganization. See “ <a href="#">DISPOLDDS control statement</a> ” on page 135.
DYNALLOC	( <i>a,b,c</i> ), <i>x</i> or <i>d,x</i>  Each of <i>a</i> , <i>b</i> , <i>c</i> , and <i>d</i> is either YES or NO	YES,Z	Specifies dynamic allocation of input database data sets, shadow database data sets, and index data sets. See “ <a href="#">DYNALLOC control statement</a> ” on page 136.
NAMESWAP	YES or NO	NO	Specifies to perform post-reorganization processing (data set name swapping and DBRC notification) after successful reorganization. See “ <a href="#">NAMESWAP control statement</a> ” on page 147.
SINDEXSUF	YES or NO	NO	Specifies whether each shadow index has the name of the original index with a suffix character at the end. See “ <a href="#">SINDEXSUF control statement</a> ” on page 156.
SPACEALLOC	YES NO YES,FORCE	NO	Specifies whether to allocate DASD space for each shadow data set within the Smart Reorg utility job step. See “ <a href="#">SPACEALLOC control statement</a> ” on page 156.

## Database access and state

Use the following control statement keywords to change the database access allowed during the reorganization and the database state after the reorganization. The Smart Reorg utility issues DBRC commands to change database access and IMS commands to change database state.

Table 18. Control statements for database access and state

Keyword	Acceptable values	Default	Description
DBRCAUTHCMD	YES or NO	NO	Specifies whether the Smart Reorg utility issues a CHANGE.DB READON or a CHANGE.DB NOAUTH command at the beginning of reorganization and a CHANGE.DB NOAUTH command before name swapping. See <a href="#">“DBRCAUTHCMD control statement” on page 131.</a>
DBSHARE	YES or NO	NO if DBRC is active. No default if DBRC is not active.	Specifies whether to allow read-only access to the database while it is being reorganized. See <a href="#">“DBSHARE control statement” on page 132.</a>
ICNEEDED	ON or OFF	If DBRC is active, <ul style="list-style-type: none"> <li>• ON for recoverable (RECOVABL) databases</li> <li>• OFF for non-recoverable (NONRECOV) databases</li> </ul> No default if DBRC is not active.	Specifies whether the DBRC ICNEEDED flag is turned on after name swapping. See <a href="#">“ICNEEDED control statement” on page 138.</a>
IMSCMD	NO YES,EMCS YES,TOSI	NO	Specifies whether the Smart Reorg utility issues a /DBR or /DBD command at the beginning of reorganization and a /DBR command before name swapping. See <a href="#">“IMSCMD control statement” on page 140.</a>
IMSCMDOPT	<i>a,b</i> <i>a</i> =ALL, DBD, DBR, or STA <i>b</i> =LOCAL or GLOBAL	None	Specifies the option parameters for the IMS commands that IMS Tools Online System Interface issues. See <a href="#">“IMSCMDOPT control statement” on page 142.</a>

Table 18. Control statements for database access and state (continued)

Keyword	Acceptable values	Default	Description
LASTAUTHFLAG	OFF or ORIGINAL	OFF if DBRC is active. No default if DBRC is not active.	Specifies the state of the READ ONLY flag and the PROHIBIT AUTHORIZATION flag in RECON after post-reorganization processing ends. See <a href="#">“LASTAUTHFLAG control statement” on page 146.</a>
STARTDB	YES or NO	NO	Specifies whether to start the database after the completion of post-reorganization processing. See <a href="#">“STARTDB control statement” on page 158.</a>

## Reports

Use the following control statement keywords to generate additional reports.

Table 19. Control statements for reports

Keyword	Acceptable values	Default	Description
DECODEDBD	(a,b) or c Each of a, b, and c is either YES or NO	NO	Specifies whether to decode the original and new DBDs and print the resulting DBD source statements in reports. See <a href="#">“DECODEDBD control statement” on page 133.</a>
DECODESXD	(a,b) or c Each of a, b, and c is either YES or NO	NO	Specifies whether to decode secondary index DBDs related to the original and new DBDs and print the resulting DBD source statements in reports. See <a href="#">“DECODESXD control statement” on page 134.</a>
STATRL	YES or NO	NO	Specifies whether the Reload task generates detailed database statistics reports in the HPSSTAT data set. See <a href="#">“STATRL control statement” on page 159.</a>

Table 19. Control statements for reports (continued)

Keyword	Acceptable values	Default	Description
STATUL	YES or NO	NO	Specifies whether the Unload task generates detailed database statistics reports in the HPSLIST data set. See <a href="#">“STATUL control statement”</a> on page 160.

## IPRPIPE

Use the following control statement keywords to tune IPRPIPE. It is recommended that you use default values unless you need to use specific values.

Table 20. Control statements for IPRPIPE

Keyword	Acceptable values	Default	Description
PIPEBLKSZ	(a,b) a=1024 - 65536, b=1 or 2	(32768,1) and (32768,2)	Specifies how many records can be moved to or from the pipe at one time. See <a href="#">“PIPEBLKSZ control statement”</a> on page 151.
PIPEDEPTH	(a,b) a=2 - 32767, b=1 or 2	(62,1) and (62,2)	Specifies the number of blocks that can be in the pipe at any given time before the pipe becomes full. See <a href="#">“PIPEDEPTH control statement”</a> on page 152.
PIPEWAIT	(a,b),x, or a,x a=1 - 1440, b=1 or 2, x=RDWR or OPEN	(15,1),RDWR (0.5,1),OPEN (15,2),RDWR (0.5,2),OPEN	Specifies the amount of time a writer or reader of a pipe can remain in a wait state before the Smart Reorg Driver issues a message and abends. See <a href="#">“PIPEWAIT control statement”</a> on page 152.

## Error handling

Use the following control statement keywords to control the behavior of the utility when the process fails.

Table 21. Control statements for error handling

Keyword	Acceptable values	Default	Description
AUTHFAIL	WTOR or ABORT	ABORT if DBRC is active. No default if DBRC is not active.	Specifies the action the Smart Reorg utility takes when DBRC authorization fails during initialization processing and before name swapping. See <a href="#">“AUTHFAIL control statement”</a> on page 128.
NAMESWAPFAIL	WTOR ABORT BACKOUT	ABORT	Specifies the action taken in case a name swapping error occurs. See <a href="#">“NAMESWAPFAIL control statement”</a> on page 148.

## ADDBGRP control statement

Specifies the database group name to be sent with the system notification to Autonomics Director.

**Requirement:** The Autonomics Director server must be configured and active. For more information, see the *IMS Tools Base Autonomics Director User's Guide and Reference*.

This control statement is used when `ADXCFCGRP=xcfggrpname` is also specified.

`dbgrpname` is a 1- to 8-alphanumeric character string. The default is `ADDBGRP=*NO`.

```

  ┌─── *NO ───┐
  │           │
  └─── dbgrpname ───┘
  ── ADDBGRP= ──┬───▶
  
```

## ADXCFCGRP control statement

Specifies the XCF group name of the Autonomics Director server. When IMS Database Reorganization Expert utility processing ends, the utility sends the results with system notification to the specified Autonomics Director server.

If an error occurs in the initialization process of the utility, system notification is not sent to Autonomics Director.

`xcfggrpname` is a 1- to 8-alphanumeric character string. This control statement is optional. The default is `ADXCFCGRP=*NO`.

```

  ┌─── *NO ───┐
  │           │
  └─── xcfggrpname ───┘
  ── ADXCFCGRP= ──┬───▶
  
```

To specify `ADXCFCGRP=xcfggrpname`, the following requirements must be satisfied:

- IBM IMS Database Solution Pack for z/OS or IBM IMS Database Utility Solution for z/OS is installed.
- An Autonomics Director server must be configured and active. For more information, see the *IMS Tools Base Autonomics Director User's Guide and Reference*.
- The SHKTLLOAD library of IMS Tools Base is included in the STEPLIB concatenation.
- DBRC is active. If DBRC is not active, the `ADXCFCGRP` control statement is ignored.

## AUTHFAIL control statement

Specifies the action Reorganization Manager takes when DBRC authorization fails during initialization processing and before name swapping.

DBRC authorization can fail when the database is used online or used by a batch job.

This control statement is optional. The default is AUTHFAIL=ABORT.



### ABORT

If DBRC authorization fails, the job stops with a return code of 8. If authorization fails at initialization phase, no updates are made to the shadow database. If authorization fails just before name swapping, updates are made to the shadow database but name swapping is not performed.

### WTOR

If DBRC authorization fails, Reorganization Manager issues a message to the operator requesting an appropriate action, which depends on the DBSHARE option. The operator can cancel the batch job that caused the authorization failure, and issue one of the following replies:

- CANCEL, which cancels the Smart Reorg job.
- RETRY, which lets Reorganization Manager attempt to get authorization from DBRC again. This could lead to another operator request if authorization fails again. The Smart Reorg job is stopped after 10 unsuccessful attempts.

If the operator issues CANCEL and FORCE is specified for the third parameter of the STARTDB control statement, the Smart Reorg utility sends a /START DB command to the IMS online subsystems to which the /DBR command has been issued by the Smart Reorg utility. For details, see [“STARTDB control statement” on page 158](#).

If the operator issues RETRY and the subsequent DBRC authorization succeeds, the Smart Reorg job continues processing. If NAMESWAP=YES is specified and post-reorganization processing ends successfully, Reorganization Manager automatically issues the CHANGE.DB AUTH READOFF command unless LASTAUTHFLAG=ORIGINAL is specified. If you specify LASTAUTHFLAG=ORIGINAL, Reorganization Manager automatically issues the CHANGE.DB command to restore authorization flags in RECON to the original state. For details, see [“LASTAUTHFLAG control statement” on page 146](#).

To enable the AUTHFAIL control statement, DBRC must be active and the database and its indexes must be registered to DBRC.

The AUTHFAIL keyword takes effect when authorization is checked during initialization processing and before data set name swapping. Authorization level that is required during the initialization processing depends on the DBSHARE option. Exclusive authorization is required during data set name swapping.

When the Smart Reorg job ends abnormally due to a DBRC authorization failure, Smart Reorg restores DBRC flags automatically. For details, see [“Automated DBRC processing for restoring authorization flags” on page 74](#).

## CONDREORG control statement

Specifies whether to enable the Conditional Reorganization Support Service (CRSS).

This control statement is optional. The default is CONDREORG=NO.

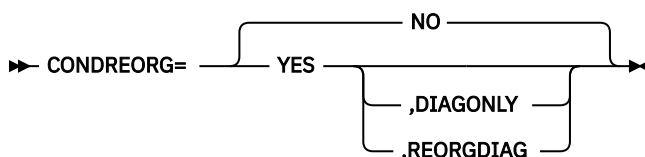



**NO**

The CRSS is not used. The job runs in Unconditional Reorganization mode, which means that the database is reorganized without being diagnosed.

**YES**

The CRSS is used. The job runs in Conditional Reorganization mode if no suboption is specified. The Smart Reorg Driver calls the CRSS to evaluate the database or each partition based on the specified reorganization policy. When the CRSS determines that the database reorganization is necessary, the Smart Reorg Driver calls the Parallel Reorganization Service to run the reorganization task. Conditional reorganization processing can be controlled by the control statements in the (CONDREORG) block.

You can specify the following suboptions for CONDREORG=YES:

**DIAGONLY**

The CRSS is used. The job runs in Diagnosis-only mode. In this mode, the CRSS is called by the Smart Reorg Driver to evaluate the database based on the specified reorganization policy and to generate a Diagnosis report.

**REORGDIAG**

The CRSS is used. The job runs in Reorganization Diagnosis mode. In this mode, the database is diagnosed and reorganized regardless of the results from policy evaluation. The Smart Reorg Driver calls the CRSS to evaluate the database or partitions based on the specified reorganization policy before and after reorganization, and generates a Diagnosis report after the reorganization is committed.

The following control statements cannot be specified with CONDREORG=YES:

- REORGINPUT=ULDS
- NEWDBD=*dbdname*
- ITKBLOAD=*libname*

**Notes:**

- When you specify CONDREORG=YES, CONDREORG=YES,REORGDIAG, or CONDREORG=YES,DIAGONLY, you must specify a valid IMS Tools KB server XCF group name with the ITKBSRVR control statement.
- If you specify CONDREORG=YES,REORGDIAG or CONDREORG=YES,DIAGONLY in the Installation Default Option Table and CONDREORG=YES in the (REORG) block of the JCL, CONDREORG=YES (without suboption) is in effect.
- In the second evaluation phase, the database statistics evaluated by the CRSS differ by the NAMESWAP control statement specification:
  - If NAMESWAP=YES, the database statistics collected after name swapping.
  - If NAMESWAP=NO, the database statistics collected before name swapping. The statistics are collected from shadow data sets and are indicated as `AFTER REORG` in reports.
- For a HALDB, the CRSS diagnoses all partitions or the partitions that the PARTITION control statement specifies. Then, the Smart Reorg utility reorganizes only the partitions that require reorganization. If a partition selection exit is defined for the HALDB, you cannot specify two or more sequential partitions in the form of PARTITION=(*partname,nnn*).
- If PSINDEXBLD=YES is specified and the CRSS identifies that only some HALDB partitions require reorganization, update mode is selected automatically. See [“PSINDEXBLD control statement” on page 153](#).
- To create an unload data set without reorganizing the database, specify UNLOADONLY=YES with CONDREORG=YES or CONDREORG=YES,REORGDIAG. For more information, see [“UNLOADONLY control statement” on page 161](#) and [“Example 16: Conditionally reorganizing a database in separate job steps” on page 202](#).

**Related concepts**

[Setting installation default options](#)

You can change the default values for some options by creating an Installation Default Option Table (HPSCOPTI) for your site.

### Related reference

[Control statements for the Conditional Reorganization Support Service](#)

The control statement block for the Conditional Reorganization Support Service contains the user specifications for controlling the CRSS process.

[ITKBSRVR control statement](#)

Specifies the name of the IMS Tools KB server XCF group.

## CRIC control statement

Specifies to create image copies of all database data sets or HALDB partitions even when the Conditional Reorganization Support Service (CRSS) determines that reorganization of the entire database or some partitions are not needed.

This control statement is optional.

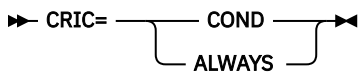

### COND

Creates image copies of only the data sets or HALDB partitions that are reorganized.

### ALWAYS

Creates image copies of all database data sets or all HALDB partitions regardless of whether reorganization is needed or not.

To specify the CRIC control statement, you must also specify the following control statements:

- CONDREORG=YES. If you specify CONDREORG=YES,REORGDIAG or CONDREORG=YES,DIAGONLY, the CRIC control statement is ignored.
- IC=YES.

### Notes:

- When CRIC=ALWAYS is specified, image copies of non-reorganized database data sets and non-reorganized HALDB partitions are created with Type-B Image Copy processing. For more information, see [“Types of Image Copy processing when CRIC=ALWAYS”](#) on page 111.
- The CRIC control statement cannot be specified when UNLOADONLY=YES is specified.

## CRUNLOAD control statement

Specifies to create an unload data set that contains data from the database or HALDB partitions. You can choose to create an unload data set only when the Conditional Reorganization Support Service (CRSS) determines that reorganization is needed or every time the job is run (regardless of whether reorganization is needed).

This control statement is optional.

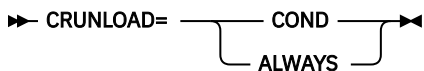

### COND

Creates an unload data set only when the CRSS determines that reorganization is needed. For HALDB, only the data from the partitions that will be reorganized is included in the unload data set.

### ALWAYS

Creates an unload data set. For HALDB, data from the entire database is included in the unload data set.



If you specify DBRCAUTHCMD=YES, Reorganization Manager issues one of the following DBRC commands at the beginning of the reorganization:

- If DBSHARE=YES, CHANGE.DB DBD(*name*) READON
- If DBSHARE=NO, CHANGE.DB DBD(*name*) NOAUTH

If you specify CRIC=ALWAYS, CRUNLOAD=ALWAYS, or both, even if DBSHARE=NO is specified, a CHANGE.DB DBD(*name*) READON command is issued for the database (non-HALDB) or for each HALDB partition (HALDB) that require no reorganization.

If the database to be reorganized is a HALDB partition or partitions, the command is issued for each partition. If it is an entire HALDB, the command is issued for each partition.

The CHANGE.DB READON command changes the READ ONLY flag of the database in RECON, and the database can be authorized only for read processing. The CHANGE.DB NOAUTH command changes the PROHIBIT AUTHORIZATION flag of the database in RECON. Therefore, authorization processing is prohibited for the database.

If one or more errors are detected during reorganization processing, the Smart Reorg utility issues the CHANGE.DB command to restore the READ ONLY flag or the PROHIBIT AUTHORIZATION flag before ending abnormally. For details, see [“Automated DBRC processing for restoring authorization flags” on page 74.](#)

The Smart Reorg utility must have exclusive access to the database before doing data set name swapping. If you specify DBRCAUTHCMD=YES, Reorganization Manager automatically issues a CHANGE.DB NOAUTH command immediately before data set name swapping.

If IMSCMD=NO, DBRCAUTHCMD=YES, and AUTHFAIL=ABORT are specified and Reorganization Manager fails to get the required authorization from DBRC, the job is stopped. If IMSCMD=NO, DBRCAUTHCMD=YES, and AUTHFAIL=WTOR are specified, the AUTHFAIL=WTOR option becomes effective after Reorganization Manager fails to get the required authorization from DBRC.

When you specify DBRCAUTHCMD=YES, DBRC must be active and the database must be registered to DBRC.

If you specify DBRCAUTHCMD=NO, it is recommended that you specify AUTHFAIL=WTOR. If you specify DBRCAUTHCMD=NO and you have not issued either the CHANGE.DB READON or the CHANGE.DB NOAUTH command for the database, the AUTHFAIL=WTOR option makes Reorganization Manager issue a WTOR message HPSG0336A stating what type of authorization is required for the database.

If you specify IMSCMD=YES, the DBRCAUTHCMD control statement is ignored and has no effect.

**Note:** Even if the Smart Reorg utility issues the DBRC command successfully, if the database is being used by any other IMS system, authorization is not allowed for the database. If you are using the database online, it is recommended that you authorize DBRC by using the IMS command.

## DBSHARE control statement

Specifies whether read access for the database is allowed while the database is being reorganized.

This control statement is optional. The default is DBSHARE=NO.

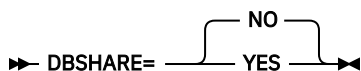

### NO

Specifies that the access to the database is prohibited. Exclusive authorization must be acquired.

### YES

Specifies that the read-only access to the database is allowed while the database is being reorganized.

In either case, the action taken by Reorganization Manager when the required authorization is not acquired depends on the AUTHFAIL option. See [“AUTHFAIL control statement” on page 128.](#)

To enable the DBSHARE control statement, DBRC must be active and the database and its indexes must be registered to DBRC.

## DDNMAP control statement

Specifies the mapping from DD names of input database data sets to those of shadow data sets.

The mapping can be specified as a pattern or as pairs of DD names. This statement can be specified only for non-HALDBs.

This control statement is optional. If you do not specify this control statement, the following pattern is used:

```
DDNMAP=(%%%- ---- , TMP-----)
```

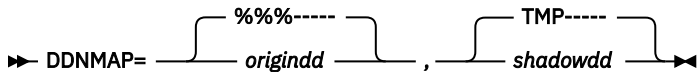

The first parameter *origindd* specifies the DD name of an input database data set; and, the second parameter *shadowdd* specifies the DD name of the shadow database data set corresponding to the DD name specified by the first parameter.

You can specify, at most, one DDNMAP control statement for each DD name of the input database data set.

You can specify the mapping by using a text string pattern. If the first parameter starts with either a percent (%) or a minus (-) sign, the statement is recognized as specifying a pattern string. The shadow DD name is created as follows: the characters of a DD name at the positions of the percent symbols are replaced by the character at the same positions in the second parameter of the DDNMAP statement. For example, if you specify DDNMAP=( ---%%%- -- , ---TMP-- ) , shadow DD name CUSTMP01 is created from original DD name CUSTOM01. You can specify only one pattern in a set of DDNMAP control statements. If you specify a pattern must be the first DDNMAP statement in a set of DDNMAP control statements. If you specify a pattern, each of *origindd* and *shadowdd* must be specified in an 8-byte character string as you can see in the default pattern.

For DD names for which a name pair is specified, the name pair specifications have precedence over the specification by a pattern.

### Examples:

Assume that the input database has DD names CUSTOM01, CUSTOM02, and CUSTOM03.

1. If you specify the following DDNMAP control statement, shadow DD names TMPTOM01, TMP02, and TMPTOM03 are created.

```
DDNMAP=(CUSTOM02, TMP02)
```

The first and third DD names are created by the default mapping pattern, and the second DD name is created by the DDNMAP control statement.

2. If the following DDNAMP control statements are specified, shadow DD names CUSTMP01, TMP02, and CUSTMP03 are created.

```
DDNMAP=( -- -%%%- -- , ---TMP-- )  
DDNMAP=(CUSTOM02, TMP02)
```

**Note:** Any DD name that starts with SYS, DFS, HPS, or IIU is reserved for system use.

## DECODEDBD control statement

Specifies whether to decode the original DBD and the new DBD and print the resulting DBD source statements in the Decoded DBD report and the Decoded New DBD report.

This control statement requires IMS Library Integrity Utilities. See [“Software prerequisites” on page 39](#).

This control statement is optional. The default is DECODEDBD=NO.

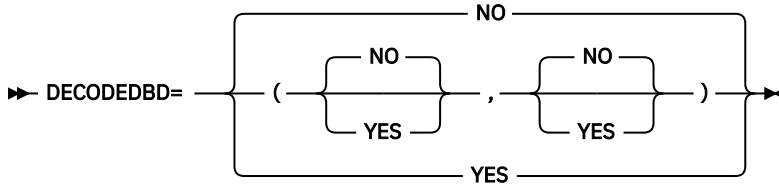

The first subparameter specifies whether to decode the original DBD. If you specify YES, the resulting DBD source statements are printed in the Decoded DBD report.

The second subparameter specifies whether to decode the new DBD in the library that the NEWDBD control statement specifies. If both the NEWDBD control statement and DECODEDBD=(xxx,YES) are specified, the resulting DBD source statements are printed in the Decoded New DBD report.

Specifying DECODEDBD=YES is the same as specifying DECODEDBD=(YES,YES), and specifying DECODEDBD=NO is the same as specifying DECODEDBD=(NO,NO).

**Notes:**

- For HIDAM databases, DBDs for the primary database and the primary index are decoded.
- The DECODEDBD control statement must not be specified in the (UNLOAD) block or the (RELOAD) block.

**Tip:** You can change the default value of this control statement by creating an Installation Default Option Table (HPSCOPTI). For more information, see [Chapter 45, “Setting installation default options,”](#) on page 617.

## DECODESXD control statement

Specifies whether to decode secondary index DBDs related to the original DBD and the new DBD, and print the resulting DBD source statements in the DBD Decoded report and the New DBD Decoded report.

This control statement requires IMS Library Integrity Utilities. See [“Software prerequisites”](#) on page 39.

This control statement is optional. The default is DECODESXD=NO.

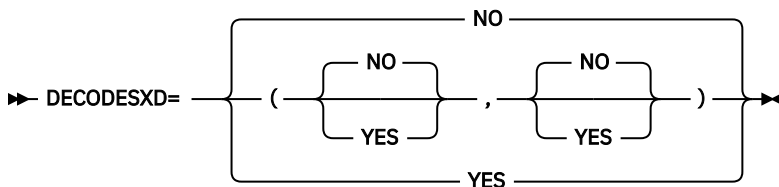

The first subparameter specifies whether to decode secondary index DBDs that are related to the original DBD. If you specify YES, the resulting DBD control statements are printed in the Decoded DBD report.

The second subparameter specifies whether to decode secondary index DBDs that are related to the new DBD. If both NEWDBD control statement and DECODESXD=(xxx,YES) are specified, the resulting DBD source statements are printed in the Decoded New DBD report.

Specifying DECODESXD=YES is the same as specifying DECODESXD=(YES,YES), and specifying DECODESXD=NO is the same as specifying DECODESXD=(NO,NO).

**Note:** The DECODESXD control statement must not be specified in the (UNLOAD) block or in the (RELOAD) block.

**Tip:** You can change the default value of this control statement by creating an Installation Default Option Table (HPSCOPTI). For more information, see [Chapter 45, “Setting installation default options,”](#) on page 617.

## DELOLDDS control statement

Specifies whether to delete old input database data sets and secondary index data sets after successful reorganization.

This control statement is optional. The default is DELOLDDS=NO.

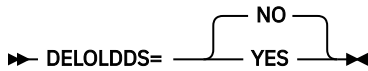

### YES

When name swapping and DBRC notification complete successfully, the old input database data sets are deleted. If you also specify INDEXBLD=YES,NEW or PSINDEXBLD=YES,NEW, the old secondary index data sets are also deleted.

- If DELOLDDS=YES is specified for a HALDB partition that is not online reorganization capable, the old input database data sets are deleted.
- If DELOLDDS=YES is specified for an online reorganization capable HALDB partition whose A-through-J and X data sets were active before parallel reorganization, old input A-through-J and X data sets are deleted.
- If DELOLDDS=YES is specified for an online reorganization capable HALDB partition whose M-through-V and Y data sets were active before parallel reorganization, both the old input M-through-V and Y data sets and the old A-through-J and X data sets, if they exist, are deleted.

DELOLDDS=YES is effective only when NAMESWAP=YES is specified.

### NO

No old data sets are deleted.

If DISPOLDDS control statement is specified, the DELOLDDS control statement is not allowed.

## DISPOLDDS control statement

Specifies the disposition of original data sets after successful reorganization.

This control statement is optional. The default is DISPOLDDS=TEMPNAME.

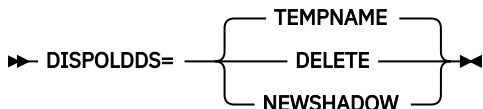

If NAMESWAP=YES is specified, first, the old original data sets are renamed to temporary data set names. Then, the data sets are processed according to the DISPOLDDS parameter:

- If DISPOLDDS=TEMPNAME, the old data sets remain with temporary names with suffix '.T'.
- If DISPOLDDS=DELETE, the old data sets are deleted.
- If DISPOLDDS=NEWSHADOW, the temporary data sets are renamed to shadow names with suffix '.Z'. If you want to change the suffix character, use the [“DYNALLOC control statement”](#) on page 136.

**Note:** If both SPACALLOC=YES and the DDEFPPDS2 DD statement are specified, old data set name plus suffix '.T' is used for temporary data set names. The names defined in the DDEFPPDS2 data set are used for shadow data sets. For details, see [“SPACEALLOC control statement”](#) on page 156.

DISPOLDDS=DELETE is allowed only when NAMESWAP=YES is specified. DISPOLDDS=TEMPNAME and DISPOLDDS=NEWSHADOW can be specified independent of NAMESWAP. If NAMESWAP=NO and DISPOLDDS=NEWSHADOW are specified, the Smart Reorg utility generates a sequence of IDCAMS commands for renaming temporary data set names to shadow data set names for use in manual name swapping.

The DISPOLDDS control statement is a functional replacement of the DELOLDDS control statement. The DISPOLDDS control statement and the DELOLDDS control statement are mutually exclusive.



DISPOLDDS=TEMPNAME has the same meaning as DELOLDDS=NO, and DISPOLDDS=DELETE has the same meaning as DELOLDDS=YES.

**Tip:** You can change the default value of this control statement by creating an Installation Default Option Table (HPSCOPTI). For more information, see [Chapter 45, “Setting installation default options,” on page 617.](#)

## DYNALLOC control statement

Specifies whether the data sets for the input and shadow databases and the indexes are dynamically allocated.

The DYNALLOC control statement specifies whether to allocate the following data sets:

- Original and shadow data sets for the database, the primary index, and the HALDB indirect list data set
- Data sets for secondary indexes of non-HALDB

This control statement is optional. The default is DYNALLOC=YES,Z.

Unless SPACEALLOC=YES specified, DASD spaces for shadow data sets or output secondary index data sets must be preallocated in an IDCAMS step before the Smart Reorg utility step. For automatic allocation of DASD space, see [“SPACEALLOC control statement” on page 156.](#)

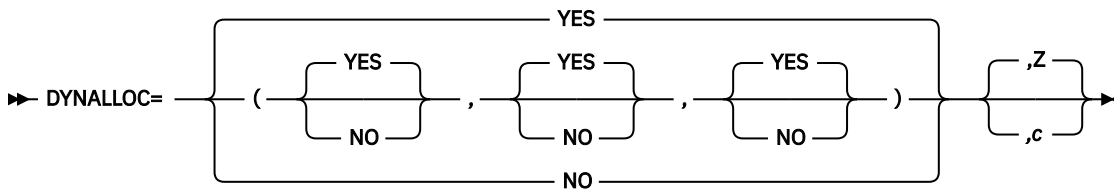

The three subparameters (*DYNALLOC parameters*) of the first parameter for the DYNALLOC statement specify whether to dynamically allocate the following data sets:

- First subparameter: Data sets for the original database and the original primary index
- Second subparameter: Data sets for the shadow database and the shadow primary index
- Third subparameter: Data sets in which the secondary indexes are to be rebuilt

For each subparameter, YES specifies to allocate data sets dynamically. If you specify NO, you must specify the corresponding data sets in the JCL stream. DYNALLOC=YES means DYNALLOC=(YES,YES,YES); and DYNALLOC=NO means DYNALLOC=(NO,NO,NO). For a HALDB, the first subparameter must be YES.

DYNALLOC=(xxx,xxx,YES) specifies to dynamically allocate the data sets that are used by the Index Builder task as output. If INDEXBLD=YES,CURRENT, data sets for the original secondary indexes are allocated. If INDEXBLD=YES,NEW, data sets for the shadow secondary indexes are allocated. In both cases, the DFSMDA member for the original secondary indexes for the non-HALDB must be present. For more information about output secondary index data sets, see [“INDEXBLD control statement” on page 143](#) and [“Secondary indexes” on page 106](#). For partitioned secondary indexes (PSINDEXes), see [“PSINDEXBLD control statement” on page 153.](#)

The second parameter *c* specifies a suffix character, other than 'T'. The names of shadow data sets are created by adding the suffix to the corresponding original data set names. The default suffix is 'Z'. For example, if the original data set is named IMS.TESTDB01, the shadow data set is named IMS.TESTDB01.Z.

If the shadow data set names are not appropriate, you should specify DYNALLOC=(xxx,NO,xxx) or DYNALLOC=(xxx,xxx,NO) and specify the shadow data set names in the JCL stream. For DD names for the primary database and primary index, see [“DDNMAP control statement” on page 133](#) in the case of a non-HALDB, and see [“Database, primary index, and ILDS” on page 104](#) in the case of a HALDB. For secondary indexes of a non-HALDB, for either INDEXBLD=YES,CURRENT or INDEXBLD=YES,NEW, use the DD names that are defined in the DBD in the job step.



**Note:** If you specify both SPACEALLOC=YES and the DDEFPS2 data set, the second parameter is ignored. The name of each shadow data set is determined from the information defined in the DDEFPS2 data set. For details, see [“SPACEALLOC control statement” on page 156](#).

IBM recommends that you use DYNALLOC=YES.

#### Notes:

- For a non-HALDB, DFSMDA members are used to allocate the original database and original indexes. You can use the IMSDALIB DD statement to specify the library that contains DFSMDA members. For more information about the IMSDALIB DD statement, see [“DD names common to all processing options” on page 95](#).
- If DBRC is active, as it always is for a HALDB, the data sets of the original database and original indexes, including secondary indexes if INDEXBLD=YES or PSINDEXBLD=YES, must be registered to DBRC. For a non-HALDB, if a data set name that is defined in the DFSMDA member differs from the data set name registered to DBRC, the job ends abnormally.
- For a HALDB, indirect list data sets (ILDSs) are included in the set of original or shadow database data sets. If ILDSBLD=NO is specified or there is no segment for which the indirect list entry (ILE) is to be created, shadow ILDSs are not used and there is no need to preallocate shadow ILDSs.
- For a HALDB, if M-through-V and Y data sets are active, shadow database data sets are named with the names of the corresponding A-through-J and X data sets with a suffix character c added.
- If all of the following conditions are met, XTIO (extended task input/output table) is used to allocate each HALDB data set dynamically:
  - All the STEPLIB libraries are APF-authorized.
  - (If one or more OSAM data sets are included) The NON\_VSAM\_XTIO option is present in the DEVSUPxx member of PARMLIB.
  - The DBALLABOVE statement is specified in the DFSVSAMP data set.

If the DFSVSAMP data set is dynamically allocated and if other conditions are met, the DBALLABOVE statement is automatically added to the DFSVSAMP data set. However, if all database data sets are OSAM LDS data sets, the DBALLABOVE statement is not automatically added. This is true even when the NON\_VSAM\_XTIO option is not present.

## HPIO control statement

Specifies whether to use the High Performance I/O Driver in the Reload task and the Image Copy task.

This control statement is optional. HPIO=xxx specified in the (REORG) block overrides the HPIO control statement in each subtask.

If you do not specify this control statement, the value for the HPIO option is determined as follows:

- If the libraries specified on the STEPLIB DD statement are not APF-authorized, HPIO=NO is used.
- Otherwise, the HPIO option of each subtask is effective.

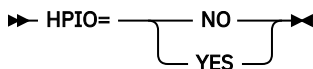

#### NO

High Performance I/O Driver is not used for output database data sets in each subtask.

#### YES

High Performance I/O Driver is used for output database data sets in each subtask.

**Tip:** You can change the default value of this control statement by creating an Installation Default Option Table (HPSCOPTI). For more information, see [Chapter 45, “Setting installation default options,” on page 617](#).

## IC control statement

Specifies whether to generate image copies of the reorganized database.

This control statement is optional. The default is IC=NO.

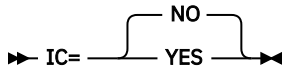

### YES

The Image Copy control task is attached to generate image copies of all database data sets. You can select the type of image copy processing by coding the ICTYPE control statement. For details about the ICTYPE control statement, see [“ICTYPE control statement” on page 139](#).

You can specify options for Image Copy processing by coding control statements for IMS HP Image Copy in the ICEIN data set. For details about supported control statements, see [“Control statements for the Image Copy task” on page 177](#).

You can specify IC=YES for a non-HALDB that has internal logical relationships and has no external logical relationships. For such a database, you must also specify PREFIXRES=YES.

For databases with logical relationships that do not need Prefix Resolution and Update after the Smart Reorg job step, you can specify IC=YES. For more information, see [“Logical relationships that do not require Prefix Resolution and Update” on page 110](#).

IC=YES requires that an appropriate version of IMS HP Image Copy is installed. For details, see [“Software prerequisites” on page 39](#).

### NO

The Image Copy task is not attached and no image copy is generated. In this case, you need to generate image copies in a later job step or in a separate job.

## ICNEEDED control statement

Specifies whether DBRC should have the Image Copy Needed (ICNEEDED) flag turned on or off for the reorganized database and primary index, and for secondary indexes built by the Index Builder task.

If you specify NAMESWAP=YES and data set name swapping succeeds, Reorganization Manager always issues NOTIFY.REORG commands for the reorganized database and primary index. If you specify INDEXBLD=YES or PSINDEXBLD=YES, the NOTIFY.REORG command is issued also for secondary indexes.

### Notes:

- Neither NOTIFY.REORG nor NOTIFY.UIC is issued for the primary index of PHIDAM and ILDSs of PHDAM or PHIDAM.
- If DBRC is not active or NAMESWAP=NO is specified, the ICNEEDED control statement is ignored and has no effect.
- If IC=YES is specified, the ICNEEDED control statement is ignored.

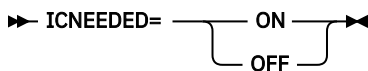

If the control statement is not specified, the default is set according to DBRC settings:

- If the database is registered as RECOVABL, the default is ICNEEDED flag turned on.
- If the database is registered as NONRECOV, the default is ICNEEDED flag turned off by using the NOTIFY.UIC command.

The following table summarizes how the ICNEEDED control statement is interpreted:

Table 22. How ICNEEDED control statement is interpreted

ICNEEDED control statement	Databases defined as RECOVABL	The primary databases or the primary index that is defined as NONRECOV	A secondary index data set that is defined as NONRECOV - When the processing option INDEXBLD=YES or PSINDEXBLD=YES is specified	A secondary index data set that is defined as NONRECOV - When the processing option INDEXBLD=NO or PSINDEXBLD=NO is specified
Not specified	ICNEEDED flag is turned on.	NOTIFY.UIC command is issued to turn off the ICNEEDED flag.	NOTIFY.UIC command is issued to turn off the ICNEEDED flag.	Neither NOTIFY.REORG nor NOTIFY.UIC command is issued.
ICNEEDED=ON	ICNEEDED flag is turned on.	ICNEEDED flag is turned on.	ICNEEDED flag is turned on.	Neither NOTIFY.REORG nor NOTIFY.UIC command is issued.
ICNEEDED=OFF	NOTIFY.UIC command is issued to turn off the ICNEEDED flag.	NOTIFY.UIC command is issued to turn off the ICNEEDED flag.	NOTIFY.UIC command is issued to turn off the ICNEEDED flag.	Neither NOTIFY.REORG nor NOTIFY.UIC command is issued.

## ICTYPE control statement

Specifies the type of Image Copy processing. This control statement is optional and is effective only when IC=YES is specified.

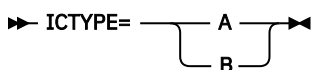

ICTYPE=A specifies Type-A Image Copy; ICTYPE=B specifies Type-B Image Copy.

If IC=YES is specified, the default value of ICTYPE is determined based on the following rules:

- For a non-HALDB database that has no logical relationship or a HALDB database, ICTYPE=A is assumed.
- For an HDAM or HIDAM database that has internal logical relationships, ICTYPE=B is assumed. In this case, you must specify PREFIXRES=YES.

For information about databases supported by each processing type, see [“Considerations for Image Copy processing”](#) on page 110. For information about unsupported databases, see [“Smart Reorg restrictions and requirements”](#) on page 58.

## ILDSBLD control statement

Specifies whether to build Indirect List data sets (ILDSs) for the HALDB in the Smart Reorg job step. This statement is applicable only to HALDBs.

This control statement is optional. The default is ILDSBLD=YES,COND.

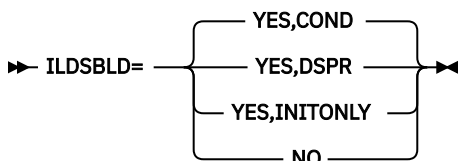

### YES,COND

Applies either YES,DSPR or YES,INITONLY. If both of the following conditions are met, YES,INITONLY is applied. Otherwise, YES,DSPR is applied.

- Either PSINDEXBLD=YES is specified in the (REORG) block or WFPHLQ=*hlq* is specified in the (RELOAD) block.
- HALDB has no logical relationships defined.

### YES,DSPR

An ILDS for each reorganized HALDB partition is built in the shadow ILDS in the Smart Reorg job step. Unlike the IMS HD Reorganization Reload utility (DFSURGL0), which updates the indirect list entries (ILEs) in the original ILDS, the Smart Reorg utility creates new ILEs in the shadow ILDS. For the data flow of the ILDS building, see the figures in [“Data and process flow of the Parallel Reorganization Service”](#) on page 75. For details about how the DD names and data set names for the shadow ILDS are determined when ILDSBLD=YES,DSPR is specified, see [“Database, primary index, and ILDS”](#) on page 104.

### YES,INITONLY

The shadow ILDS is initialized but no ILEs are built. Use ILDSBLD=YES,INITONLY only when the HALDB has no logical relationships and every PSINDEX is rebuilt after the HALDB reorganization. This statement reduces the required space for the ILDS and the elapsed time of the HALDB reorganization. Do not use this statement for a HALDB that has logical relationships because ILEs must always be built for such a HALDB.

### NO

No shadow ILDS is processed. If the HALDB has an ILDS and ILDSBLD=NO is specified, you must rebuild ILDS after the Smart Reorg job. To do this, scan the reorganized database by using DFSPRECO or IMS Index Builder.

### Notes:

- The ILE records that are created by the Smart Reorg utility with ILDSBLD=YES,DSPR are the same as the records created by DFSPRECO.
- ILDSBLD=YES is obsolete. If you specify ILDSBLD=YES, ILDSBLD=YES,COND is applied.

## IMSCMD control statement

Specifies whether Reorganization Manager issues the /DBD or /DBR command automatically at the beginning of the reorganization and before data set name swapping.

This control statement is optional. The default is IMSCMD=NO.

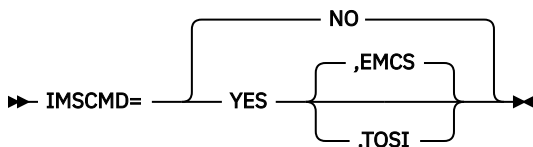

To enable IMSCMD=YES, you must complete the setup as described in [“Setting up for using E-MCS console for IMS command processing”](#) on page 50. DBRC must be active and the database must be registered to DBRC.

### IMSCMD=YES

#### IMSCMD=YES,EMCS

Reorganization Manager issues one of the following IMS commands at the beginning of the reorganization through an E-MCS console for an online IMS subsystem:

- If DBSHARE=YES, /DBD DATABASE *name* GLOBAL NOFEOV.
- If DBSHARE=NO, /DBR DATABASE *name* GLOBAL NOFEOV.

If you specify CRIC=ALWAYS, CRUNLOAD=ALWAYS, or both, even if DBSHARE=NO is specified, a /DBD DATABASE *name* GLOBAL NOFE0V is issued for the database (non-HALDB) or for each HALDB partition (HALDB) that require no reorganization.

When you specify DBSHARE=YES, /DBR command is issued immediately before data set name swapping. Through E-MCS, the /START DB command is not supported. Therefore, issue a /STA command manually. If the database to reorganize is a HALDB partition, the IMS command is issued for the partition. If the reorganization is for the entire HALDB, the IMS command is issued for the master database and for each partition.

### **IMSCMD=YES,TOSI**

Reorganization Manager uses IMS Tools Online System Interface and issues one of the following IMS commands at the beginning of reorganization:

- If DBSHARE=YES, /DBD DATABASE *name* LOCAL NOFE0V
- If DBSHARE= NO, /DBR DATABASE *name* LOCAL NOFE0V

If you specify CRIC=ALWAYS, CRUNLOAD=ALWAYS, or both, even if DBSHARE=NO is specified, a /DBD DATABASE *name* LOCAL NOFE0V is issued for the database (non-HALDB) or for each HALDB partition (HALDB) that require no reorganization.

The LOCAL option is included in these commands and the command is sent to each online IMS subsystem. The /DBD command is sent to each subsystem that is authorized to the database by DBRC with the UPDATE or the EXCLUSIVE access intent. The /DBR command is sent to each subsystem on which the database is started or stopped. Before issuing the command, Reorganization Manager issues the DBRC CHANGE.DB NOAUTH or READON command to turn on the prohibit authorization flag or the read only flag.

If you specify DBSHARE=YES, a /DBR command is issued just before data set name swapping. If you specify STARTDB=YES together with this control statement, a /START DB command is issued after the post-reorganization processing. For more information, see [“STARTDB control statement” on page 158.](#)

### **Notes:**

- You must set up the IMS Tools Online System Interface PROCLIB member for each online IMS subsystem. For more information, see the description of IMS Tools Online System Interface in the *IMS Tools Base IMS Tools Common Services User's Guide and Reference*.
- If the database in a subsystem is used by a program in the BMP region, you must stop the program before starting the Smart Reorg utility job.
- You can change the option parameters of IMS commands by using IMSCMDOPT control statements. For more information, see [“IMSCMDOPT control statement” on page 142.](#)
- If IMS commands are issued by IMS Tools Online System Interface, all IMS subsystems that share the database must be defined in the TOSI XCF group that the TOSIXCFGRP control statement specifies.
- If E-MCS is used and the /DBD or the /DBR commands have not ended within 20 seconds on all the IMS subsystems, message HPSG0334I, which indicates that one or more IMS subsystems are still using the database, is issued.
- If IMS Tools Online System Interface is used and a program that runs in the BMP region is using the database, message HPSG2102I, which indicates that one or more IMS subsystems are still using the database, is issued. In this case, /DBD or /DBR commands are not issued. If you specify TOSITEST=(*max,interval*), Reorganization Manager waits for the IMS subsystems to release the database.

Issuing the /DBD command against a non-HALDB or a HALDB partition places the database or the partition in read-only (INQONLY) mode for all IMS online systems. Issuing the /DBR command against a non-HALDB or a HALDB partition places the database or the partition in the STOPPED, NOT OPEN status, and further authorization is prohibited in all IMS online systems.

Before data set name swapping, the Smart Reorg utility must have exclusive access to the database. If you specify IMSCMD=YES, Reorganization Manager automatically issues a /DBR command immediately before data set name swapping.

If IMSCMD=YES and AUTHFAIL=ABORT are specified and Reorganization Manager fails to get required authorization from DBRC, the job stops. If IMS Tools Online System Interface is used and the database on an IMS online subsystem is in use by an online application program, the job stops without issuing a /DBD or a /DBR command.

If IMSCMD=YES and AUTHFAIL=WTOR are specified, the AUTHFAIL=WTOR option becomes effective after Reorganization Manager fails to get the required authorization from DBRC.

If you specify IMSCMD=NO, it is recommended that you specify AUTHFAIL=WTOR. If you specify IMSCMD=NO and you have not issued /DBD or /DBR commands for the database, the AUTHFAIL=WTOR option lets Reorganization Manager issue a WTOR message HPSG0336A that states what type of authorization is required for the database.

## IMSCMDOPT control statement

The IMSCMDOPT control statement specifies option parameters for the IMS commands that are issued through the IMS Tools Online System Interface (TOSI).

By using IMSCMDOPT control statements, you can specify the GLOBAL option for the /DBD, /DBR, and /STA commands.

This control statement is optional. If you do not specify this control statement, option parameters that are described in [“IMSCMD control statement”](#) on page 140 and [“STARTDB control statement”](#) on page 158 are used.

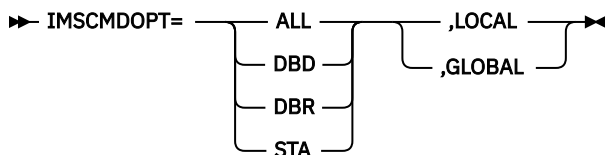

The IMSCMDOPT control statement must be specified with IMSCMD=YES,TOSI.

The first parameter specifies the IMS commands to apply the option parameter change among the IMS commands that are issued during a Smart Reorg Driver job.

### ALL

Applies to all IMS commands.

### DBD

Applies to /DBD commands.

### DBR

Applies to /DBR commands.

### STA

Applies to /STA commands.

The second parameter specifies the option parameter for the IMS command that is specified with the first parameter.

### LOCAL

The LOCAL option is used.

### GLOBAL

For /DBD, /DBR, and /STA commands, the GLOBAL option is used.

### Notes:

- One or more IMSCMDOPT control statements can be specified. However, when the first parameter is ALL, only one IMSCMDOPT control statement can be specified.
- The GLOBAL option is effective when IRLM is active.

- When the GLOBAL option is specified, the Smart Reorg Driver selects an IMS subsystem in the TOSI XCF group and, by using TOSI, issues the IMS command with the GLOBAL option to the IMS subsystem. The IMS Command Processing report shows the result of the command only for that IMS subsystem. The results on other IMS subsystems are not shown.

## INDEXBLD control statement

Specifies whether the secondary indexes for the database are built in the Smart Reorg job step.

The INDEXBLD control statement is an optional control statement for non-HALDBs. To build secondary indexes of a HALDB, see [“PSINDEXBLD control statement” on page 153](#).

The default is INDEXBLD=NO.

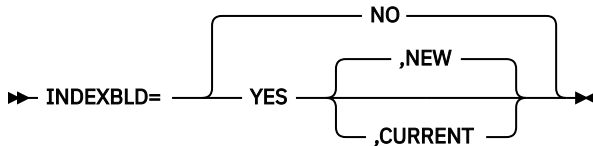

### YES

The Index Builder task is attached to build all secondary indexes for the database.

If INDEXBLD=YES,NEW, secondary indexes are rebuilt in new data sets.

If INDEXBLD=YES,CURRENT, secondary indexes are rebuilt in the data sets that are being used.

For details about how DD names and data set names are processed when INDEXBLD=YES is specified, see [“Secondary indexes” on page 106](#).

If INDEXBLD=YES is specified for a database that has no secondary index, the INDEXBLD control statement is ignored and the processing continues.

### NO

The Index Builder task is not attached and no secondary index is built. If the database has a secondary index and INDEXBLD=NO is specified, you must either reorganize the secondary index or rebuild it from the reorganized database, for example, by using IMS Index Builder in a separate step.

### Requirements:

- INDEXBLD=YES requires that a supported version of IMS Index Builder is installed. For details, see [“Software prerequisites” on page 39](#).
- You must set up IMS Index Builder to enable this control statement. For details, see [“Setting up IMS Index Builder” on page 49](#).

## ITKBDATA control statement

Specifies the type of additional data to store in the IMS Tools Knowledge Base repository.

This control statement is effective only when ITKBSRVR=*servername* is specified.

This control statement is optional. The default is ITKBDATA=\*NO, which means the utility stores no utility history data in the IMS Tools Knowledge Base repository.



ITKBDATA=UTILHIST specifies to store the utility history member for the Smart Reorg job in the IMS Tools KB Sensor Data repository. The stored utility history member contains the reorganization timestamp, which indicates the time when the database or the HALDB partitions were reorganized. Utility history members are not created for indexes and PSINDEX partitions.



If you use the rule IBM.LAST\_REORG.10, which is for evaluating the number of days that have elapsed since the last reorganization, the utility refers to the timestamp that is stored in the IMS Tools KB repository. Therefore, when you use the rule IBM.LAST\_REORG.10, you must also specify ITKBDATA=UTILHIST. For a use case scenario, see [“Example 14: Conditional reorganization based on the number of days since the last reorganization”](#) on page 199.

To learn more about utility history, see the topic "Utility history environment" in the *IMS Tools Base IMS Tools Knowledge Base User's Guide and Reference*.

**Notes:**

- If NAMESWAP=NO is specified, the ITKBDATA=UTILHIST control statement is ignored.
- If you are using the Pre-reorganization utility and the Post-reorganization utility, you can store the utility history data by specifying the ITKBDATA=UTILHIST control statement in the HPSIN data set for the Pre-reorganization utility. The utility history member is created during the Post-reorganization utility job step.

**Tip:** You can change the default value of this control statement by creating an Installation Default Option Table (HPSCOPTI). For more information, see [Chapter 45, “Setting installation default options,”](#) on page 617.

### ITKBLOAD control statement

Specifies the name of the load module library for IMS Tools Knowledge Base.

This control statement is used only when ITKBSRVR=*servername* is specified. If you do not specify the ITKBSRVR control statement, ITKBLOAD=\*NO is used and Smart Reorg utility attempts to load the IMS Tools Knowledge Base module from STEPLIB libraries.

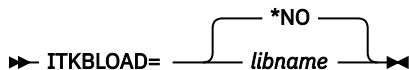

**Requirements:**

- When STEPLIB needs to be APF-authorized, this library also needs to be APF-authorized.
- This control statement can be specified only when CONDREORG=NO is specified. If you specify CONDREORG=YES, CONDREORG=YES,REORGDIAG, or CONDREORG=YES,DIAGONLY, the load module library of IMS Tools Knowledge Base must be specified in the STEPLIB concatenation.

**Tip:** You can change the default value of this control statement by creating an Installation Default Option Table (HPSCOPTI). For more information, see [Chapter 45, “Setting installation default options,”](#) on page 617.

### ITKBSRVR control statement

Specifies the name of the IMS Tools KB server XCF group.

This control statement is optional. The default is ITKBSRVR=\*NO.

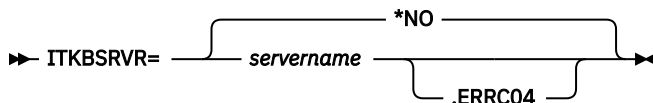

If ITKBSRVR=*servername* is specified and the job is run in Conditional Reorganization mode, in Reorganization Diagnosis mode, or in Diagnosis-only mode, the Smart Reorg utility retrieves the designated reorganization policy from the Input repository of the IMS Tools KB server and stores database statistics into the Sensor Data repository of the server.

If ITKBSRVR=*servername* is specified, the Smart Reorg utility attempts to connect to the server and then to store the following reports in the Output repository of IMS Tools KB:



- Environment report
- HPSIN Control Statements report
- HALDB Process Summary report
- Segment Count Summary report (produced in Unload task)
- Segment Count Summary report (produced in Reload task)
- Data Set Information report
- Diagnosis report

If `ITKBSRVR=servername,ERRC04` is specified and the Smart Reorg utility encounters an error in IMS Tools KB Output repository processing, the utility returns return code 4. If `ERRC04` is not specified and an error is encountered in IMS Tools KB Output repository processing, the return code is 0.

**Note:** See [“Report reference for Smart Reorg” on page 217](#) for a list of report names that are used in IMS Tools KB.

If the level of each optional product is high enough to support the Output repository, its reports are also stored.

**Requirement:** `ITKBSRVR=servername` requires that an appropriate version of IMS Tools KB is installed and the server is started. For more information, see [“Software prerequisites” on page 39](#). For information about configuring the IMS Tools KB environment, see [“Task 2: Completing configuration for IMS Tools Knowledge Base” on page 44](#).

**Tip:** You can change the default value of this control statement by creating an Installation Default Option Table (HPSCOPTI). For more information, see [Chapter 45, “Setting installation default options,” on page 617](#).

## KEYLABELCHK control statement

Specifies to check the integrity of the key labels that are assigned to the database data sets. If the key labels are different from those defined in the RACF data set profile or the SMS data class, the Conditional Reorganization Support Service (CRSS) determines that the database requires reorganization.

This control statement is optional. The default is `KEYLABELCHK=NO`.

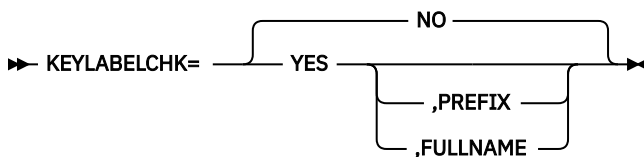

### NO

Does not check the integrity of the key labels associated with the database data set.

### YES

The CRSS checks the integrity of the key labels assigned to the database data sets.

The CRSS obtains key labels from the RACF data set profile or the SMS data class and compares them against the key labels assigned to the database data sets. If they are different, the CRSS determines that the database requires a reorganization. When the CRSS obtains key labels, it allocates one work data set for each database data set. The names of work data sets are determined based on the suboption that you specify (PREFIX or FULLNAME).

### Notes:

- To specify `KEYLABELCHK=YES`, you must also specify `CONDREORG=YES`. If you specify `CONDREORG=NO`, `CONDREORG=YES,REORGDIAG`, or `CONDREORG=YES,DIAGONLY`, the `KEYLABELCHK` control statement is ignored.
- If `KEYLABELCHK=YES` is specified with `UNLOADONLY=YES`, the `KEYLABELCHK` control statement is ignored.

- If shadow database data sets are allocated before the conditional reorganization job is started, the key labels of the shadow database data sets must match the key labels defined in the RACF data set profile or the SMS data class.
- The key labels of the shadow database data sets, which are specified with the DDEFPDS2 DD statement, must be the same as the key labels defined in the RACF data set profile or the SMS data class.
- Because key labels are not assigned to OSAM data sets, key labels are not checked if the original database data set is OSAM.
- KEYLABELCHK=YES cannot be specified when migrating from an OSAM data set to an OSAM LDS data set or from an OSAM LDS data set to an OSAM data set. If you want to run a reorganization job that involves such migration, specify CONDREORG=NO.

You can specify the following suboptions for KEYLABELCHK=YES:

#### **PREFIX**

Specifies that the CRSS allocates work data sets (for obtaining key labels) using the data set name prefix defined with the DSNPREFIX parameter of DBRC.

PREFIX is applicable to HALDBs. If specified for a non-HALDB, the Smart Reorg utility uses FULLNAME.

#### **Notes:**

- The work data sets for obtaining key labels are allocated with the following size:

```
DEFINE CLUSTER (NAME(keyLabel.dataset.name) -
              CISZ(80) RECSZ(73 73) REC(1) )
```

If you are using ACS routines that change the SMS data class based on the allocation size, the key label you intended might not be assigned. In such a case, use FULLNAME.

- The SMS data class that is used when allocating the work data sets must be the same SMS data class that is used by the original database data set of the first data set group of the first partition to be processed by the Smart Reorg utility. If the SMS data class is different for each data set, use FULLNAME.

#### **FULLNAME**

Specifies that the CRSS allocates work data sets (for obtaining key labels) with the following naming convention:

- Use the same SMS data class as the original database data sets.
- Add one-character suffix to the data set name.

The CRSS allocates one work data set for each database data set that the Smart Reorg utility processes.

**Note:** If you use a RACF data set profile to manage key labels, you must use a generic profile. If you use a discrete profile that matches the database data set name, the work data set that is used to obtain the key label will be allocated with one-character suffix and, therefore, the intended key label might not be assigned.

## **LASTAUTHFLAG control statement**

Specifies the state of the READ ONLY flag and the PROHIBIT AUTHORIZATION flag in RECON after post-reorganization processing has ended.

This control statement is optional. The default is LASTAUTHFLAG=OFF.

➔ LASTAUTHFLAG=  ➔

## OFF

Issues the CHANGE.DB AUTH READOFF command to turn off all authorization flags.

## ORIGINAL

Issues the CHANGE.DB command to restore the authorization flags to the original state.

## Notes:

- When NAMESWAP=NO is specified, the Smart Reorg utility does not do post-reorganization processing automatically. However, the CHANGE.DB command that is influenced by the LASTAUTHFLAG control statement is printed in the DBRC Notification Command Stream report.
- In the following cases where additional manual post-reorganization is required, the Smart Reorg utility does not issue the CHANGE.DB command. Therefore, the LASTAUTHFLAG control statement is ignored.
  - NEWDBD control statement is specified (message HPSG0371I is issued)
  - ILDSBLD=NO is specified though ILDS needs to be rebuilt (message HPSG0374W is issued)
  - Manual prefix resolution and update are needed because the database has either external logical relationships or HISAM internal logical relationships (message HPSG0379W is issued)
  - PREFIXRES=NO is specified though prefix resolution and update are needed (message HPSG0377I is issued)
- When the database has secondary indexes and INDEXBLD=NO or PSINDEXBLD=NO is specified, the Smart Reorg utility does not issue the CHANGE.DB command for the secondary indexes after reorganization. Therefore, the LASTAUTHFLAG control statement has no effect on secondary indexes.

## NAMESWAP control statement

Specifies whether to automatically run post-reorganization processing after successful reorganization.

Post-reorganization processing includes data set name swapping and DBRC notification. For details about post-reorganization processing, see [“Post-reorganization processing”](#) on page 212.

This control statement is optional. The default is NAMESWAP=NO.

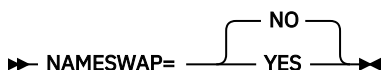

## YES

Performs name swapping. Shadow data sets are renamed to the original data set names, that is, the sets of names of original and shadow data sets are swapped.

The following conditions must be satisfied to specify NAMESWAP=YES:

- DBRC is active.
- All databases being reorganized, including the secondary indexes, are registered to DBRC.
- Names that are used for the shadow data sets for the primary database and primary index are not registered to DBRC.

If you specify NAMESWAP=YES, the names of the primary database and primary index data sets are swapped. The secondary index databases are swapped only if INDEXBLD=YES,NEW or PSINDEXBLD=YES,NEW is specified. Before a name swapping can occur, Reorganization Manager obtains exclusive authorization for the database from DBRC. (If you specified DBSHARE=NO, authorization has already been obtained.)

In the name swapping process, each original data set name, including the VSAM component name, is renamed to the original name plus the suffix .T. Therefore, the original name must contain no more than 42 characters. If it contains more, the job step ends without swapping names. You can see which data sets or VSAM components have been renamed and suffixed with .T, by checking the Result of Name Swapping report.

Renamed original data sets can be deleted or renamed to shadow data set names. For more information, see [“DISPOLDDS control statement”](#) on page 135.

You can also select the action that is taken in case a name swap failure occurs by using NAMESWAPFAIL control statements. For example, NAMESWAPFAIL=BACKOUT specifies that the data set names be restored to the names the data set had when the name swapping process started. For more information, see [“NAMESWAPFAIL control statement”](#) on page 148.

If name swapping succeeds, Reorganization Manager issues DBRC NOTIFY.REORG commands for the reorganized database and the primary index. If you specify INDEXBLD=YES or PSINDEXBLD=YES, the NOTIFY.REORG command is also issued for each secondary index.

## NO

Name swapping is not done.

If you run the job with NAMESWAP=NO, you are responsible for ensuring that the name swapping takes place after the reorganization. For details, see [“Post-reorganization processing”](#) on page 212.

## Notes:

- Whether you specify NAMESWAP=NO or YES, the original database data sets and the shadow database data sets *must* be cataloged in the same MVS catalog. IBM recommends that you use the same high-level qualifier for both sets of data set names.
- Even if an HDAM or a HIDAM database has logical relationships, you can specify NAMESWAP=YES. For external logical relationships, you must run IMS Prefix Resolution and Prefix Update utilities after Smart Reorg utility job steps. For post-reorganization processing for these databases, see [“Post-reorganization processing for database with logical relationships”](#) on page 214.
- If you specify INDEXBLD=YES,NEW or PSINDEXBLD=YES,NEW, be careful when name swapping is done for the secondary indexes. For more information, see [“Secondary indexes”](#) on page 106.
- For a HALDB, you can have the Smart Reorg utility do post-reorganization processing automatically by specifying the NAMESWAP=YES control statement, even if the database has logical relationships with another database.
- If ILDSBLD=NO is specified or no ILE is created when you reorganize HALDB partitions, no shadow ILDS is used. In this case, ILDS is excluded from the name swapping process. If ILDSBLD=YES and NAMESWAP=YES are specified and one of the following conditions is satisfied, the name swapping between the original ILDS and the shadow ILDS is done for each HALDB partition that is to be reorganized:
  - Dynamic allocation of shadow data sets is designated and all shadow ILDSs exist.
  - The shadow ILDSs of all partitions that are to be reorganized are specified in the JCL stream.
- For a HALDB partition with active DBDS in the M-through-V and Y side, the shadow data sets are renamed to the data set names of A-through-J and X side, and the original data sets remain as they are. DBRC command CHANGE.DB OLRDBDS(A) is issued after name swapping.

## NAMESWAPFAIL control statement

Specifies the action which the Smart Reorg utility takes when the IDCAMS program returns an error during name swapping.

This control statement is optional. This control statement is ignored unless NAMESWAP=YES is specified. The default is NAMESWAPFAIL=ABORT.

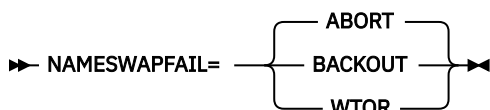

### ABORT

The Smart Reorg utility ends abnormally without the automated backout processing. After the Smart Reorg utility job, the manual backout processing is required by using the IDCAMS command stream produced in the HPSGSWAP data set.

**Note:** IBM recommends that the HPSGSWAP data set is specified in the JCL stream.

## BACKOUT

The Smart Reorg utility attempts the automated backout processing to restore the data set names to the names at the start of name swapping. After the backout processing, the DBRC flags, which are the READ ONLY flag and the PROHIBIT AUTHORIZATION flag, are also restored automatically to the original state.

## WTOR

The Smart Reorg utility issues a message to request the operator's action and reply. One of the following replies is allowed:

### CANCEL

The behavior of the Smart Reorg utility is the same as NAMESWAPFAIL=ABORT.

### RETRY

The Smart Reorg utility attempts to issue the failed IDCAMS command again and continue the name swap processing. Before this reply, the appropriate operation is needed to avoid another failure. The number of retries allowed is 10.

### BACKOUT

The behavior of the Smart Reorg utility is the same as NAMESWAPFAIL=BACKOUT.

## NEWDBD control statement

Enables you to change the DBD during reorganization. You cannot change DBD of a HALDB unless you reorganize the entire database.

DBD can be changed only when the job runs in Unconditional Reorganization mode. If you specify this control statement for a job that runs in Conditional Reorganization mode, Reorganization Diagnosis mode, or Diagnosis-only mode, the job ends with an error.

► NEWDBD= 

### *ddname*

Specifies a 1- to 8-byte DD name of the library containing the new DBD definition (the DBD that is used by the Reload task and the Index Builder task). The library defined by the IMS DD statement contains the original definition (the DBD that is used by the Unload task).

**Note:** Any DD name that is reserved for system use cannot be specified for the NEWDBD statement. For details about reserved DD names, see [“DD statements” on page 90](#).

When you change DBDs, you are responsible for ensuring that the new DBD is valid. DBD changes that are supported in parallel reorganization are described in [“Supported DBD changes” on page 149](#). If you need to change any DBD parameter that is not supported in parallel reorganization, you must reorganize the database by using stand-alone utilities. In general, you should make major changes to database structures outside of the reorganization.

### **\*STAGING**

Specifies to obtain new database definitions from the IMS catalog staging data set instead of from IMS catalog directory data sets. This keyword is applicable only when the IMS management of ACBs is enabled. The database definition and all index definitions must exist in the IMS catalog staging data set.

For information about post-reorganization processing that is required when the NEWDBD control statement is specified, see [“Considerations for post-reorganization processing” on page 150](#).

## Supported DBD changes

When using a new DBD for a non-HALDB, you can change any DBD parameters except for the following:

- Database organization
- Access method

- Number of data set groups
- DD names
- Segment hierarchy
- Changing a fixed-length segment to a variable-length segment, and vice versa
- Lessening the length of the sequence field of a segment
- Changing the start position of the sequence field
- Changing the type of the sequence field from M to U
- Adding a logical relationship

Logical relationships must not be deleted when you use a new DBD for a HALDB.

If INDEXBLD=YES is specified, changing the secondary index definition to one that is not supported by IMS Index Builder is not allowed.

To make the following changes for segment compression, specify DECOMPRESS=YES for the Unload task.

- Adding, deleting, or changing the COMPRTN parameter of a SEGM statement
- Changing the length of a compressed segment

To make the following changes to HDAM, specify SORT=YES or SORT=COND for the load task.

- Changing randomizing module name or randomizing parameters
- Increasing the length of the root sequence key

If a new secondary index is added and you want to run the Smart Reorg job with DBRC=Y and NAMESWAP=YES, you must issue the DBRC INIT.DB command to register the new secondary index in advance.

Unless DECOMPRESS=YES is specified for the Unload task, the following DBD changes are not allowed for a database that has a segment for which a Segment Edit/Compression routine is defined:

- Add COMPRTN parameter to a SEGM statement
- Remove COMPRTN parameter from a SEGM statement
- Change the value for COMPRTN parameter of a SEGM statement
- Change the length of a segment for which COMPRTN parameter is specified in the original DBD
- Lessen the length of the sequence field of a segment for which COMPRTN parameter is specified in the original DBD

**Note:** The default of the DECOMPRESS option for the Unload task is DECOMPRESS=NO.

## Considerations for post-reorganization processing

If NEWDBD control statement is specified, DBRC PROHIBIT AUTHORIZATION flags are not turned off automatically after the name swap processing. This enables you to perform some tasks such as running the ACBGEN or updating DBD libraries before you allow access to the reorganized database. You must run the DBRC utility (DSPURX00) to turn off this flag after you have made an image copy of the database and before using the database. For details, see [“Performing manual DBRC notification processing” on page 213](#). Steps [“2” on page 213](#) to [“3” on page 214](#) apply in this case because the NOTIFY.REORG commands are issued by Reorganization Manager in the Smart Reorg job step.

## PARTITION control statement

Specifies the HALDB partitions to reorganize. The control statement is applicable only to HALDBs.

This control statement is optional. The default is PARTITION=\*ALL.

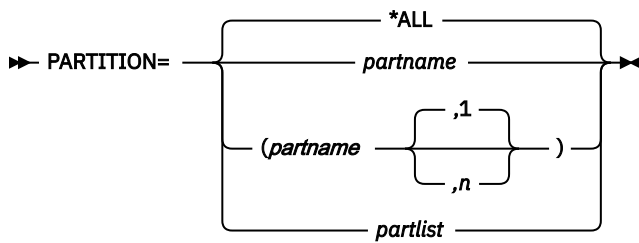

**\*ALL**

Specifies that all partitions are reorganized.

**partname**

Specifies the partition name from which the reorganization is started.

**n**

Specifies the number of partitions to reorganize. The reorganization starts from partition *partname*, and the consecutive *n*-1 partitions are reorganized in the partition selection sequence. Value *n* can be 1 - 1001, both inclusive. If the number of consecutive partitions that start with the partition *partname* is less than *n*, all consecutive partitions that start with *partname* are selected. If this parameter is not specified, the default value of 1 is assumed.

The following statements have the same meaning:

- PARTITION=PARTA
- PARTITION=(PARTA)
- PARTITION=(PARTA,1)

**partlist**

Specifies a list of partition names to reorganize. The partition names must be separated by commas and enclosed in parentheses. You can specify up to 1001 names separated into multiple statements as follows:

```
PARTITION=(part1,part2,part3,part4,part5)
PARTITION=(part6,part7,part8,part9,part10)
```

The order of partitions to reorganize is based on this list, not on the HALDB partition selection exit routine or the HALDB high key values. You can specify non-sequential partitions.

## PIPEBLKSZ control statement

Specifies how many records can be moved to and from a pipe at one time.

The block size specified for PIPEBLKSZ must include the data length (up to 32,756 bytes) plus 4 bytes for the internal block descriptor word (BDW).

If you change the PIPEBLKSZ specification, you might need to change the value of the REGION parameter to avoid running out of virtual storage.

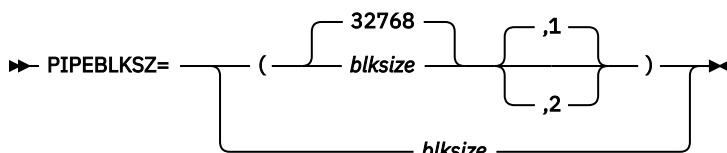

The first parameter *blksize* specifies the block size for the pipe identified by the second parameter, which specifies a pipe ID. For the valid pipe IDs, see "[Notes on pipe ID.](#)" If only the *blksize* value is specified, it applies to the pipe of pipe ID 1.

The default block size is 32768 for each pipe. The maximum value is 65536, and the minimum value is 1024. If the PSINDEXBLD=YES option is specified, the minimum value for pipe ID 2 is 7258. The

minimum value must be larger than or equal to the maximum length of the records you are to transfer through the pipe, plus four.

**Notes on pipe ID:**

Pipe ID is a number that identifies a pipe allocated between tasks running in a Parallel Reorganization job. The following pipes are allocated:

- The pipe between the Unload task and the Reload task. This pipe is always allocated and has pipe ID 1.
- The pipe between the Reload task and the Index Builder task. This pipe is allocated only when INDEXBLD=YES or PSINDEXBLD=YES is specified; it has pipe ID 2.

**PIPEDEPTH control statement**

Specifies the number of blocks that can be in a pipe at any given time before the pipe becomes *full*.

The use of large values for PIPEDEPTH enables the Smart Reorg utility to accumulate more information in virtual storage. This can be helpful in smoothing out periodic wait periods during which the writing task is forced to wait because the pipe temporarily becomes full. The pipe becomes full because the reading task is temporarily delayed in reading data from the pipe.

If you change the PIPEDEPTH specification, you might need to change the value of the REGION parameter to avoid running out of virtual storage.

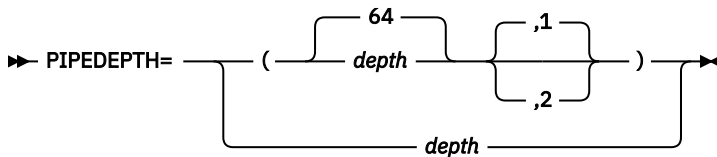

The first parameter *depth* specifies the number of blocks that can be held in the pipe, which is identified by the second parameter, at any given time before the pipe becomes *full*. The second parameter specifies a pipe ID. For the valid pipe IDs, see "[Notes on pipe ID](#)". If only the *depth* value is specified, it applies to the pipe of pipe ID 1.

The value of *depth* can be in the range of 2 - 32767. The default value is 62 for each pipe.

**PIPEWAIT control statement**

Specifies the amount of time a writer or a reader of a pipe can remain in a wait state before the Smart Reorg Driver issues a message and abends.

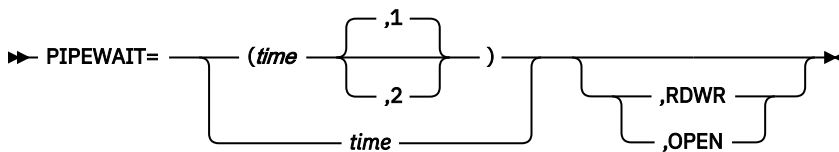

The first parameter *time* specifies how many minutes, in the range of 1 - 1440, a writer or a reader, connecting to the pipe that is specified by the second parameter, can remain in a wait state.

The second parameter specifies the pipe ID. If no pipe ID is specified, pipe ID 1 is used for the second parameter. This means that the PIPEWAIT specification is applied to the pipe that has pipe ID of 1. For information about valid pipe IDs, see [Notes on pipe ID](#) in "[PIPEBLKSZ control statement](#)" on page 151.

The third parameter specifies the target to apply the wait state:

**RDWR**

Specifies to apply the wait state to the read and write wait state of the pipe.

**OPEN**

Specifies to apply the wait state to the open wait state of the pipe.



If the third parameter is not specified, this control statement applies to both the wait state in opening the pipe and the wait state in getting a pipe block to write or read.

If the Smart Reorg Driver remains in a wait state longer than the specified interval, IMS Database Reorganization Expert issues a message and ends abnormally.

The default time value is 15 (minutes) for each pipe when the data is read from or written to the pipe, and is 0.5 minutes when a reader or writer task waits for the partner task to open the pipe.

**Tip:** You can change the default value of this control statement by creating an Installation Default Option Table (HPSCOPTI). For more information, see [Chapter 45, “Setting installation default options,”](#) on page 617.

## PREFIXRES control statement

The PREFIXRES control statement specifies whether to do prefix resolution and prefix update in the Smart Reorg job step for HDAM or HIDAM that has internal logical relationships.

**Note:** If the database has external logical relationships, PREFIXRES=YES is ignored. The prefix resolution and update utilities are needed after the Smart Reorg jobs.

This control statement is optional. The default is PREFIXRES=NO.

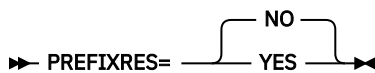

### YES

If the database is an HDAM or HIDAM and has internal logical relationships, the prefix resolution and prefix update are done for the shadow data sets that have been reloaded. After that, if IC=YES and NAMESWAP=YES are specified, Type-B Image Copy processing and name swap processing are done.

### NO

Logical relationship records are written to the DFSURWF1 data set. You must run prefix resolution and update utilities using the DFSURWF1 data set.

**Note:** PREFIXRES=YES requires that a supported version of IMS HP Prefix Resolution is installed. For details, see [“Software prerequisites”](#) on page 39.

## PSINDEXBLD control statement

Specifies whether the partitioned secondary indexes (PSINDEXes) for the database are built in the Smart Reorg job step.

This control statement is optional and is used for HALDBs. If the database to reorganize is a non-HALDB, this control statement is ignored. The default is PSINDEXBLD=NO.

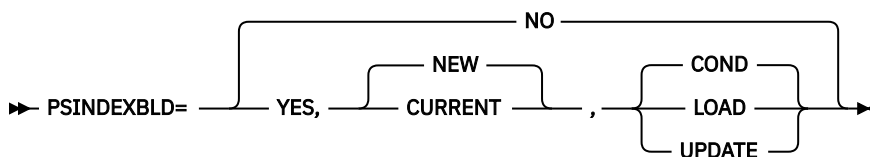

### YES

The Index Builder task is called to build all PSINDEXes for the database.

For more information about how DD names and data set names are processed when PSINDEXBLD=YES is specified, see [“Considerations for secondary indexes”](#) on page 108.

The second parameter specifies the data sets in which PSINDEXes are rebuilt:

### NEW

PSINDEXes are rebuilt in new data sets.

## CURRENT

PSINDEXes are rebuilt in existing data sets.

The third parameter specifies the processing mode for IMS Index Builder:

## COND

The processing mode for building PSINDEX is determined automatically. Update mode is selected if either of the following conditions is met:

- The PARTITION control statement specifies only some partitions of the HALDB.
- The Conditional Reorganization Support Service (CRSS) identifies that only some partitions of the HALDB require reorganization.

## LOAD

Builds PSINDEXes in load mode. In load mode, all the PSINDEX records are loaded to the PSINDEX.

## UPDATE

Builds PSINDEXes in update mode. In update mode, only the PSINDEX records that point to the reorganized HALDB partitions are updated.

- If you specify PSINDEXBLD=YES,CURRENT,UPDATE, the existing data sets for PSINDEX are updated.
- If you specify PSINDEXBLD=YES,NEW,UPDATE, all the records in the existing data sets are copied to the new data sets by the IDCAMS REPRO command, and then the new data sets are updated.

## NO

The Index Builder task is not called and no PSINDEXes are built.

**Requirement:** PSINDEXBLD=YES requires that a supported version of IMS Index Builder is installed and configured. For instructions, see [“Setting up IMS Index Builder”](#) on page 49.

## RC\_CHANGE control statement

Specifies the return code of the Smart Reorg utility that is returned when a specific event is detected during Smart Reorg utility processing.

This control statement is optional. The default is RC\_CHANGE=NONE.

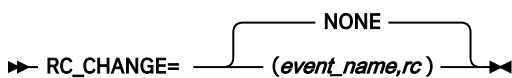

### event\_name

Specifies the name of the event to be detected in Smart Reorg utility processing. The following event name can be specified:

#### POLICY.EXCEPTIONS.CRITICAL

This event specifies a condition where one or more critical-level exceptions exist in the database. This parameter must be specified with CONDREORG=YES, CONDREORG=YES,REORGDIAG, or CONDREORG=YES,DIAGONLY.

If the Smart Reorg utility performs a database reorganization, it returns the specified return code when it detects one or more critical-level exceptions in the reorganized database.

#### POLICY.ACTION.REORG

This event specifies a condition where a database reorganization is needed for the database or for one or more HALDB partitions and the reorganization is not performed yet. This parameter can be specified with CONDREORG=YES,DIAGONLY. However, if UNLOADONLY=YES is specified, this parameter can be specified with CONDREORG=YES or CONDREORG=YES,REORGDIAG. For an example, see [“Example 16: Conditionally reorganizing a database in separate job steps”](#) on page 202.

### rc

Specifies the return code for the Smart Reorg utility that will be issued when the event is detected. The maximum value is 99, and the minimum value is 1.

## NONE

Does not change the return code. The default return codes of the Smart Reorg utility are used.

You can specify multiple RC\_CHANGE control statements, one for each event. If two or more events are detected, the largest return code is returned.

## REORGINPUT control statement

Specifies the type of input data sets for reorganization processing.

This control statement is optional. The default is REORGINPUT=DBDS.

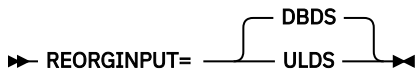

### DBDS

Database data sets are unloaded by the Unload task and unload records are passed to the Reload task through IPRPIPE.

### ULDS

Instead of unloading database data sets, unloaded data set is used as the input for reorganization processing. A DFSUINPT DD statement, which specifies the unload data set, must be present. All types of record formats supported by the IPR Unload utility can be used.

When REORGINPUT=ULDS is specified, the Reload task writes to the original database data set directly, not to the shadow database data sets. Therefore, shadow data sets are not needed. Optional tasks, Index Builder, Prefix Resolution, and Image Copy with hash pointer checking, are available. For other control statements, note the following:

- CONDREORG=YES cannot be specified. Conditional Reorganization mode is not supported.
- In the (REORG) block, DBSHARE=YES, NAMESWAP=YES, NEWDBD=*ddname*, INDEXBLD=YES,NEW, or PSINDEXBLD=YES,NEW cannot be specified. INDEXBLD=YES is interpreted as INDEXBLD=YES,CURRENT. PSINDEXBLD=YES is interpreted as PSINDEXBLD=YES,CURRENT.
- In the (RELOAD) block, the IPR Reload utility control statements listed in “Overview of the IPR Reload control statements” on page 502 can be specified except for the DBRECDIST, DECODEDBD, RAPCHAIN, ILDSBLD, and PARTINFO control statements. The DECODEDBD and the ILDSBLD control statement can be specified in the (REORG) block.
- To reorganize a HALDB, note also the following:
  - You must specify the PARTINIT control statement in the (RELOAD) block to initialize empty partitions. For details, see “PARTINIT control statement” on page 524.
  - You can specify the ILDSBLD control statement in the (REORG) block. For details, see “ILDSBLD control statement” on page 139.
  - The Smart Reorg utility requires that the partition to be reloaded is stopped and the DBRC PROHIBIT AUTHORIZATION flag is turned on. If IMSCMD=YES or DBRCAUTHCMD=YES is specified, the Smart Reorg utility issues commands automatically to meet these requirements. If you do not want to stop all the partitions, specify the PARTITION control statement in the (REORG) block to specify a partial range of partitions. In this case, if a segment is attempted to be reloaded to a partition that is out of the range, the reorganization processing is forced to terminate. For details, “PARTITION control statement” on page 150.
  - If IC=YES, image copy is taken for the partition that is reloaded or initialized.

Certain considerations apply when the IMS management of ACBs is enabled and you specify REORGINPUT=ULDS. For details, see “Considerations for the IMS management of ACBs” on page 115.

A JCL example for using REORGINPUT=ULDS is provided in “Example 11: Reloading a database and taking an image copy” on page 196.

## SINDEXSUF control statement

Specifies whether the name of each shadow secondary index is assumed to be the original name plus a suffix.

This control statement is optional. The default is SINDEXSUF=NO.

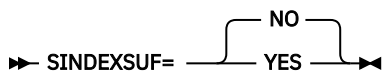

SINDEXSUF=YES is effective if all of the following conditions are met:

- DBRC is inactive.
- DYNALLOC=(xxx,xxx,NO) is specified.
- INDEXBLD=YES,NEW is specified.

If SINDEXSUF=YES is specified, it is assumed that each shadow secondary index has the data set name of the original index plus a suffix, and the Smart Reorg utility produces IDCAMS commands for renaming the shadow index to the original name. If SINDEXSUF=NO is specified, the Smart Reorg utility cannot know the name of the original index under the preceding conditions; therefore, the Smart Reorg utility does not produce IDCAMS commands for renaming the shadow index to the original name.

**Tip:** You can change the default value of this control statement by creating an Installation Default Option Table (HPSCOPTI). For more information, see [Chapter 45, “Setting installation default options,”](#) on page 617.

## SPACEALLOC control statement

Specifies whether to delete and allocate DASD space for each shadow data set within the IMS Database Reorganization Expert job step.

This control statement is optional. This control statement is used if DYNALLOC=(,YES,) or DYNALLOC=(,YES) is specified.

The default is SPACEALLOC=NO. If SPACEALLOC=NO is used, an IDCAMS step to allocate the DASD space is needed in separate from the IMS Database Reorganization Expert step.

If you specify CONDREORG=YES,DIAGONLY, the SPACEALLOC control statement is ignored and has no effect.

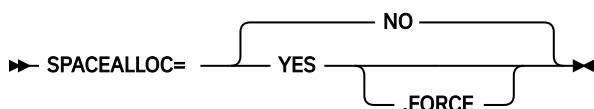

If you specify SPACEALLOC=YES, each shadow data set can be deleted and allocated within the Smart Reorg utility job step. You can specify the IDCAMS commands in the DDEFPS2 data set or the HPSGAMSA data set, otherwise the Smart Reorg utility generates the commands automatically.

### Using the DDEFPS2 data set to supply IDCAMS commands

If you specify the DDEFPS2 DD statement, which specifies the partitioned data set that contains IDCAMS commands for shadow data sets allocation, the Smart Reorg utility passes the commands to the IDCAMS program. The name of each PDS member must be the same as the DD name of the original data set.

The names of shadow data sets do not need to be in the form of `original_data_set_name + suffix`, they can have any desired names.

For HALDBs, the name of each PDS member must be the same as the DD name of the A-side data sets even when M-side data sets are active.

The following example shows IDCAMS control statements specified in a PDS member:

```
DELETE (shadow.database.data-set.name)
SET MAXCC=0
DEFINE CLUSTER(NAME(shadow.database.data-set.name)...)
OR
ALLOCATE DSNAME('shadow.database.data-set.name')...
```

In this example, the command to delete the old temporary data set (with suffix .T) is not included because the command will be added automatically.

If not all the members of the database data sets are present in the DDEFPS2 data set, the Smart Reorg utility generates IDCAMS commands for the missing database data sets.

### Using the HPSGAMSA data set to supply IDCAMS commands

If you specify the HPSGAMSA DD statement, which specifies the data set that contains IDCAMS commands for shadow data sets allocation, the Smart Reorg utility passes the commands to the IDCAMS program.

The names of shadow data sets must be in the form of `original_data_set_name + suffix`, where the suffix character is the character specified on the DYNALLOC control statement.

#### Notes:

- If the IDCAMS returns a non-zero condition code, the Smart Reorg utility ends the reorganization processing. Specify `SET MAXCC=0` after the `DELETE` command in case the used shadow data set does not exist.
- If the HPSGAMSA data set contains many IDCAMS `ALLOCATE` commands, IDCAMS processing might end without allocating some shadow database data sets. When this happens, IDCAMS message `IKJ56220I` is printed in the Result of Shadow Space Allocation report to alert data set allocation failures. If the HPSGAMSA data set contains many `ALLOCATE` commands, specify the `DYNAMNBR` parameter on the `EXEC` statement to prevent data set allocation failures.

Example:

```
//REORG EXEC PGM=HPSGMAIN,PARM='DBD=dbdname,DBRC=Y',DYNAMNBR=999
```

### Enabling automatic shadow space allocation

If both the DDEFPS2 DD statement and the HPSGAMSA DD statement are not specified, the Smart Reorg utility automatically attempts to delete and allocate the DASD space for each shadow data set based on the attributes of its original data set. For volume list and the SMS classes, see [Notes](#).

If `DYNALLOC=(,YES)` is specified with `INDEXBLD=YES,NEW` or `PSINDEXBLD=YES,NEW`, the commands for the shadow secondary index data sets are included.

For HALDBs, the commands for the shadow ILDS are included unless `ILDSBLD=NO` is specified.

If `NAMESWAP=YES`, the commands to delete the old temporary data set with suffix .T are added.

If you specify `SPACEALLOC=YES`, and a new shadow data set is already allocated or the VSAM shadow data set with the `REUSE` option remains<sup>3</sup>, the shadow data set is used without reallocating.

If you specify `SPACEALLOC=YES,FORCE`, each shadow data set is automatically deleted and allocated even if a new or reusable shadow data set is allocated before the Smart Reorg Driver job step.

Result of this processing is shown in [“Result of Shadow Space Allocation report” on page 257](#).

#### Notes:

- If a new or reusable data set with the shadow name is not found, the Smart Reorg utility generates the commands for allocation.
  - If the original data set is not SMS-managed and the old data set with the shadow name remains<sup>3</sup>, the volume list is derived from the old shadow data set. If the old shadow data set is not found, the volume list is derived from the original data set. You must take care whether there is enough available space on the volumes.
  - If the original data set is SMS-managed, the number of volumes and the SMS classes are derived from the original data set and the volumes are assigned by SMS.

- To encrypt data sets by using z/OS data set encryption, you must assign a key label to the original data set when you allocate the data set.

The Smart Reorg utility does not support the KEYLABEL parameter for allocating shadow database data sets; the key label must be specified in the RACF data set profile or SMS data class.

When a key label is specified on more than one source, the key label is derived in the following order of precedence:

- RACF data set profile
- SMS data class
- The primary space quantity for an OSAM shadow data set is determined by adding up the space allocated in the first three extents of the original data set. Therefore, the space allocated for the shadow data set might not match the space that was specified for the original data set.
- If you specify CONDREORG=YES and if the Smart Reorg utility did not reorganize the database, shadow data sets are not deleted or allocated even if you specify SPACEALLOC=YES or SPACEALLOC=YES,FORCE.

### Restrictions:

- The Smart Reorg utility does not automatically generate commands for the following data sets:
  - Shadow data set if its original is an OSAM multi-volume data set and the volumes are not SMS-managed. If the volumes are SMS-managed, the Smart Reorg utility attempts to allocate the shadow data set. The SMS storage class must have the guaranteed space attribute.
  - Output secondary index data set if INDEXBLD=YES,CURRENT or PSINDEXBLD=YES,CURRENT.
  - Output secondary index data set if INDEXBLD=YES,NEW or PSINDEXBLD=YES,NEW and its original data set is not found.
- Migrating from an OSAM data set to an OSAM LDS data set using the automatic shadow space allocation feature is not supported. You must allocate the shadow OSAM LDS data set by specifying SPACEALLOC=NO, or by using the HPSGAMSA DD statement or the DDEFPS2 DD statement.

## STARTDB control statement

Specifies whether a /START DB command is issued automatically after the completion of post-reorganization processing.

This control statement is optional. The default is STARTDB=NO.

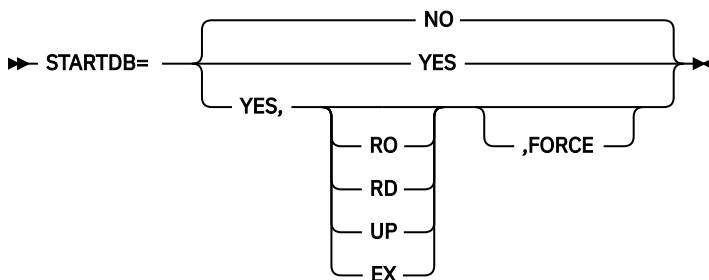

STARTDB=YES must be specified together with NAMESWAP=YES, IMSCMD=YES,TOSI, and TOSIXCFGRP=*grpname*.

<sup>3</sup> If DISPOLDDS=NEWSHADOW is specified, the input original data sets are renamed to the shadow names during the name swapping and the data sets with the shadow names remain.

If STARTDB=YES is specified, the Smart Reorg utility sends the following command to the IMS online subsystems, to which the /DBR command has been issued by the Smart Reorg utility:

```
/START DB dbname LOCAL DBALLOC
```

The second parameter of the STARTDB control statement, which is the access option and is applied as the value of the ACCESS parameter of the /START DB command, is optional and it specifies the access intent RO, RD, UP, or EX.

If the job is run for a HALDB, the /START DB command is issued for the HALDB master and HALDB partitions. If the second parameter is omitted, the ACCESS parameter is omitted and the /START DB command is issued only for HALDB partitions.

The third parameter, FORCE, is optional. This parameter specifies that if AUTHFAIL=WTOR is specified and CANCEL is entered as the response for message HPSG0336A, after the DBRC flags are restored, the Smart Reorg utility issues a /START DB command to the IMS online subsystems to which the utility previously issued the /DBR command.

### Restrictions:

- The access option of the STARTDB control statement and the GLOBAL option of the IMSCMDOPT control statement are mutually exclusive.
- If one or more of the following conditions are met, the /START DB command is not issued even if STARTDB=YES is specified:
  - Reorganization processing fails.
  - Name swap processing or DBRC notification processing fails.
  - NEWDBD control statement is specified.
  - Prefix resolution and update processing for non-HALDB is not done for logical relationships.
  - Secondary indexes building for non-HALDB is not done.
  - For HALDBs, either the ILDS is not built or the PSINDEX is not built.
  - Image Copy Needed (ICNEEDED) flag is turned on.
  - In Conditional Reorganization mode, CONDREORG=YES is specified with UNLOADONLY=YES and the CRSS determines that the database reorganization is necessary. In this case, the Smart Reorg utility expects a database reorganization to occur in the succeeding job step.

**Tip:** You can change the option parameters for the /STA commands by using IMSCMDOPT control statements. For more information, see [“IMSCMDOPT control statement”](#) on page 142.

## STATRL control statement

Specifies whether the Reload task generates detailed database statistics reports in the HPSSTAT data set.

This control statement is optional. The default is STATRL=NO.

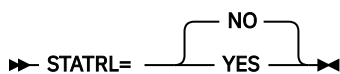

If STATRL=YES is specified, the following statistics reports are generated by the Reload task for the output database and are written to the HPSSTAT data set in the following order:

1. Data Set Statistics
2. Segment Statistics
3. Pointer Count Summary
4. Pointer Statistics

If the HPSSTAT DD statement is not coded in the JCL stream, it is dynamically allocated to the SYSOUT stream.

**Note:** For compatibility with version 2 of IMS Parallel Reorganization, if the HPSSTAT DD statement is coded in the JCL stream, these statistics reports are produced in the data set that is specified on the DD statement, even if STATRL=NO is specified.

## STATUL control statement

Specifies whether the Unload task generates detailed database statistics reports in the HPSSLIST data set. This control statement is optional. The default is STATUL=NO.

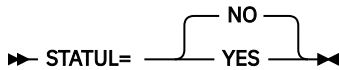

If STATUL=YES is specified, the following statistics reports are produced by the Unload task and are written to the HPSSLIST data set in the following order:

1. DB Call Statistics
2. CAB Statistics (if BUFSTAT=YES is specified in the (UNLOAD) block)

If the HPSSLIST DD statement is not coded in the JCL stream, it is dynamically allocated to the SYSOUT stream.

**Note:** For compatibility with version 2 of IMS Parallel Reorganization, if the HPSSLIST DD statement is coded in the JCL stream, these statistics reports are produced in the data set that is specified on the DD statement, even if STATUL=NO is specified.

## TOSITEST control statement

When IMSCMD=YES,TOSI is specified, before issuing IMS commands (/DBD or /DBR), Reorganization Manager verifies whether the database is being used by any BMPs. TOSITEST control statement specifies the maximum number of attempts and the interval time for this verification. Use this control statement if you want Reorganization Manager to wait for a certain amount of time for BMPs to end.

If the number of attempts reaches the maximum value set for the TOSITEST control statement and the database is still being used, the Smart Reorg utility issues message HPSG2102I to alert that /DBD or /DBR commands cannot be issued.

This control statement is optional and is effective only when IMSCMD=YES,TOSI is specified.

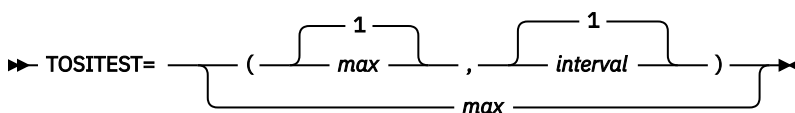

### *max*

Specifies the maximum number of attempts in the range of 1 - 9999. The default is 1.

### *interval*

Specifies, in seconds, the interval between the attempts in the range of 1 - 9999. The default is 1.

If the GLOBAL option is specified for the IMSCMDOPT control statement, Reorganization Manager verifies only one of the IMS subsystems connected through IMS Tools Online System Interface.

## TOSIWAIT control statement

Specifies the IMS Tools Online System Interface response timeout value in seconds, in the range of 0 - 9999.

This control statement is optional and effective only when IMSCMD=YES,TOSI is specified. The default is TOSIWAIT=300.

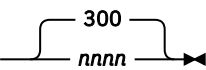

►► TOSIWAIT=  300  
nnnn

## TOSIXCFGRP control statement

Specifies the XCF group name, which is defined by the XCFGROUP parameter in the IMS Tools Online System Interface PROCLIB member.

The name is a 1-5 alphanumeric character string. For details of the XCFGROUP parameter, see the description of IMS Tools Online System Interface in the *IMS Tools Base IMS Tools Common Services User's Guide and Reference*.

If IMSCMD=YES,TOSI is used, this control statement is required.

►► TOSIXCFGRP= *grpname* ◄◄

If IMSCMD=YES,TOSI is specified, Reorganization Manager uses the XCF group name for automated IMS command processing. For details, see [“Automated IMS command processing”](#) on page 73.

If CONDREORG=YES, CONDREORG=NO, REORGDIAG, or CONDREORG=YES,DIAGONLY is specified, DB Sensor uses the XCF group name to retrieve latest VSAM statistics of online databases in the first evaluation phase of the Smart Reorg job.

Certain considerations apply when collecting statistics from a database that is being updated. For details, see [“Considerations for collecting sensor data from a database that is being updated”](#) on page 66.

## UNLOADONLY control statement

Specifies to run only the Unload task to create an unload data set without reorganizing the database.

This control statement is optional. The default is UNLOADONLY=NO.

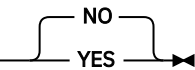
►► UNLOADONLY=  NO  
YES

### NO

Both the Unload task and the Reload task are called to reorganize the database.

### YES

Only the Unload task is called to create an unload data set. The Reload task and any other reorganization-related tasks are not called. Shadow data sets are not used.

- The DFSURGU1 DD statement is required for the unload data set.
- You can specify the format for the unload data and a user exit routine by providing the OUTPUT control statement in the (UNLOAD) block of the HPSIN control statements. For example:

```
(UNLOAD)
  OUTPUT=DFSURGU1,*HD,(MYEXIT,B)
```

If the OUTPUT control statement is omitted, OUTPUT=DFSURGU1,\*HD is used. For more information, see [“OUTPUT control statement”](#) on page 375.

- The database must be in read-only state during unload. To set the database to read-only state, specify DBRCAUTHCMD=YES, IMSCMD=YES,TOSI, and STARTDB=YES. For more information, see [“DBRCAUTHCMD control statement”](#) on page 131, [“IMSCMD control statement”](#) on page 140, and [“STARTDB control statement”](#) on page 158.

You can specify UNLOADONLY=YES in Unconditional Reorganization mode and Conditional Reorganization mode.

- When CONDREORG=YES is specified, the unload data set is created only when the CRSS determines that the database reorganization is necessary. For HALDB, the unload data set is created if one

or more partitions require reorganization, and the unload data set contains data from only those partitions.

- When CONDREORG=YES,REORGDIAG is specified, the unload data set is always created regardless of the results from CRSS policy evaluation. For HALDB, the unload data set contains data from all the partitions.
- When CONREORG=YES,DIAGONLY is specified, the Unload task is not called and, therefore, unload data set is not created.

For an example, see [“Example 16: Conditionally reorganizing a database in separate job steps” on page 202.](#)

If you specify UNLOADONLY=YES, CRIC and CRUNLOAD control statements cannot be specified.

## ZIIPMODE control statement

Specifies whether to offload eligible I/O workloads to zIIP processors.

This control statement is optional. The default is ZIIPMODE=NEVER.

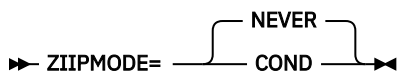

### COND

Offloads VSAM ESDS I/O or OSAM LDS I/O workloads to zIIP processors. COND is effective only when available zIIP processors are found. Otherwise, the job is run on the main CPs.

The following conditions must be satisfied to apply ZIIPMODE=COND:

- The SGLXLOAD library of IMS Tools Base is specified to the STEPLIB.
- The load module libraries of STEPLIB are APF authorized.
- The High Performance I/O Driver is activated.

If the High Performance I/O driver is inactive for some reason, even if you specify ZIIPMODE=COND, ZIIPMODE=NEVER is applied.

### NEVER

Does not offload any workload to zIIP processors. NEVER is the default to avoid unexpected performance degradation.

**Tip:** You can change the default value of this control statement by creating an Installation Default Option Table (HPSCOPTI). For more information, see [Chapter 45, “Setting installation default options,” on page 617.](#)

## Control statements for the Conditional Reorganization Support Service

The control statement block for the Conditional Reorganization Support Service contains the user specifications for controlling the CRSS process.

This control statement block starts with a line that specifies the block name (CONDREORG). The following table shows the control statements that you can specify in the (CONDREORG) block.

Table 23. Control statements for the Conditional Reorganization Support Service

Keyword	Acceptable values	Default	Description
DBS_HPIO	YES or NO	YES	Specifies whether DB Sensor uses the High Performance I/O driver to read database data sets. See <a href="#">“DBS_HPIO control statement”</a> on page 164.
DIAGDATAFROM	DBSENSOR or REPOSITORY	DBSENSOR	Specifies how the CRSS retrieves database statistics data that is to be used for database diagnosis in the first evaluation phase to determine whether reorganization is needed. See <a href="#">“DIAGDATAFROM control statement”</a> on page 164.
JOURNAL	YES or NO	NO	Specifies whether to print journal messages in the output stream. See <a href="#">“JOURNAL control statement”</a> on page 164.
POLICYBY	DBTYPE DBDNAME NAME	DBTYPE	Specifies how to select the reorganization policy that is to be used in the Smart Reorg job. See <a href="#">“POLICYBY control statement”</a> on page 165.
POLICYNM	<i>policy_name</i>	None	Specifies the name of the reorganization policy to be used. See <a href="#">“POLICYNM control statement”</a> on page 166.
PRINTRPRT	YES or NO	YES	Specifies whether to print the Diagnosis report in the SYSOUT stream. See <a href="#">“PRINTRPRT control statement”</a> on page 166.
SENSOR_HOME	YES or NO	YES	Specifies whether DB Sensor collects data elements that are related to root segment distribution. See <a href="#">“SENSOR_HOME control statement”</a> on page 166.

Table 23. Control statements for the Conditional Reorganization Support Service (continued)

Keyword	Acceptable values	Default	Description
STORERPRT	YES or NO	YES	Specifies whether to store the Diagnosis report in the Output repository of the IMS Tools KB server. See “STORERPRT control statement” on page 167.

## DBS\_HPIO control statement

Specifies whether DB Sensor uses the High Performance I/O driver to read database data sets.

This control statement is optional. The default is DBS\_HPIO=YES, which means DB Sensor uses High Performance I/O driver.

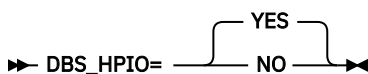

### YES

DB Sensor uses the High Performance I/O driver to read database data sets.

### NO

DB Sensor does not use the High Performance I/O driver to read database data sets.

## DIAGDATAFROM control statement

Specifies how the CRSS retrieves database statistics data that is to be used for database diagnosis in the first evaluation phase to determine whether reorganization is needed.

This control statement is optional. The default is DIAGDATAFROM=DBSENSOR, which means the CRSS requests DB Sensor to collect database statistics and uses the collected data for database diagnosis in the first evaluation phase.

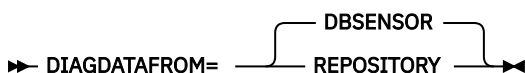

### DBSENSOR

The CRSS requests DB Sensor to collect database statistics and uses the collected statistics data.

### REPOSITORY

The CRSS does not request DB Sensor to collect database statistics in the first evaluation phase. Instead, the CRSS uses the latest statistics that were stored in the Sensor Data repository before the Smart Reorg job.

If the job is run in Conditional Reorganization mode and the database was reorganized during the job, or if the job is run in Reorganization Diagnosis mode, the database statistics data that is to be used in the second evaluation phase is collected by DB Sensor during reorganization reload.

## JOURNAL control statement

Specifies whether to print journal messages in the output stream.

This control statement is optional. The default is JOURNAL=NO, which means that journal messages are not printed in the output stream.

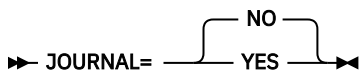

## NO

Journal messages are not printed in the output stream.

**Note:** Even if you specify JOURNAL=NO in the (CONDREORG) block, if you specify the BBEJRNL DD statement, BSNJM01 DD statement, or both in the JCL, journal messages are printed in the specified DD data sets.

## YES

Journal messages are printed in the output stream.

Messages that are issued by the DB Sensor and DB Analyzer components are printed in the output stream that is specified by the BBEJRNL DD statement. Messages that are issued by Policy Services are printed in the output stream that is specified by the BSNJM01 DD statement.

## POLICYBY control statement

Specifies how to select the reorganization policy that is to be used in the Smart Reorg job.

You can use one of the following three methods for selecting the policy:

- Select by database type
- Select by the DBD name of the database
- Select by policy name

This control statement is optional. The default is POLICYBY=DBTYPE, which means the policy is selected based on the database type.

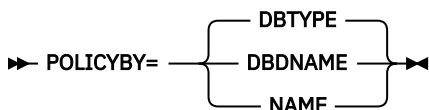

### DBTYPE

The policy is selected based on the type of the target database. DBTYPE is the default value.

When this parameter is specified, the Smart Reorg utility searches for a policy that is named SYS.DBdtype.*dbdtype* in the Input repository of IMS Tools KB. *dbdtype* is HDAM, HIDAM, PHDAM, PHIDAM, HISAM, or SHISAM.

### DBDNAME

The policy is selected based on the DBD name of the database.

When this parameter is specified, the Smart Reorg utility searches for a policy that is named SYS.DBdname.*dbdname* in the Input repository of IMS Tools KB. *dbdname* is the DBD name that is specified in the Smart Reorg JCL.

### NAME

The policy is selected based on the policy name that is specified on the POLICYNM control statement. To enable this parameter, you must also specify the POLICYNM control statement.

## Examples for using the POLICYBY control statement

Assume that you are running a conditional reorganization job for an HDAM database that is named ORDERDB. In this case:

- If you specify POLICYBY=DBTYPE, the policy that is named SYS.DBdtype.HDAM is used.
- If you specify POLICYBY=DBDNAME, the policy that is named SYS.DBdname.ORDERDB is used.
- If you specify POLICYBY=NAME, the policy that is specified on the POLICYNM control statement is used.

## POLICYNM control statement

Specifies the name of the reorganization policy to be used.

This control statement is required when POLICYBY=NAME is specified. When POLICYBY=NAME is not specified, this control statement is ignored.

This control statement has no default value.

►► POLICYNM= *policy\_name* ◄◄

### *policy\_name*

The 1- to 20-alphanumeric name of the reorganization policy.

## PRINTRPRT control statement

Specifies whether to print the Diagnosis report in the SYSOUT stream.

This control statement is optional. The default is PRINTRPRT=YES, which means the Diagnosis report is printed in the SYSOUT stream.

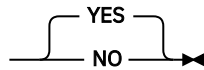
►► PRINTRPRT=  ◄◄

### YES

The Diagnosis report is printed in the SYSOUT stream that is specified by the BBERPRT DD statement.

### NO

The Diagnosis report is not printed in the SYSOUT stream.

## SENSOR\_HOME control statement

Specifies whether DB Sensor collects data elements that are related to root segment distribution.

This control statement is optional. The default is SENSOR\_HOME=YES.

►► SENSOR\_HOME=  ◄◄

### YES

DB Sensor collects the following data elements:

- DB\_NUM\_ROOT\_NOHOME
- DB\_PCT\_NUM\_ROOT\_NOHOME
- DB\_AVG\_LEN\_SYNONYM\_CHAIN

Because DB Sensor calls a randomizer to collect data for these elements, the CPU time and the elapsed time increase compared to when SENSOR\_HOME=NO is specified.

### NO

DB Sensor does not collect the data elements that are related to root segment distribution.

### Restrictions:

- If the key compression option of the Segment Edit/Compression exit routine is specified for the root segment, these data elements are not collected even when SENSOR\_HOME=YES is specified.
- If you specify RMNAME=(*rand,rap,0,bytes*) or if you omit the third operand of the RMNAME parameter in the DBD macro, the number of root addressable area (RAA) blocks is defined as zero in the HDAM or PHDAM DBD. In this case, these data elements are not collected even when SENSOR\_HOME=YES is specified.

The data elements that are additionally collected when SENSOR\_HOME=YES are useful factors for determining the need of database reorganization. For more information about these data elements, see the topic "GLOBAL command keywords for FF Stand-alone DB Sensor" in the *IMS Solution Packs: Data Sensor User's Guide*.

## STORERPRT control statement

Specifies whether to store the Diagnosis report in the Output repository of the IMS Tools KB server.

This control statement is optional. The default is STORERPRT=YES, which means the Diagnosis report is stored in the Output repository of IMS Tools KB.

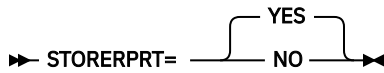

### YES

The Diagnosis report is stored in the Output repository of IMS Tools KB.

### NO

The Diagnosis report is not stored in the Output repository of IMS Tools KB.

## Control statements for the Unload task

The control statement block for the Unload task contains the user specifications for controlling the unload process.

You can code the following statements in the (UNLOAD) block of the HPSIN control statements:

- Control statements for Unload function
- Control statements for HSSR Engine

In parallel reorganization, DD name SYSUT2 specified in an OUTPUT control statement has a special meaning; data written to SYSUT2 DD by Unload task is redirected to the input (identified by DFSUINPT DD) for the Reload task.

The PARTITION control statement cannot be specified in the (UNLOAD) block. When you select HALDB partitions to reorganize, the PARTITION control statement must be specified in the (REORG) block .

The following table shows the control statements that are used to control the unload function.

Table 24. Control statements used for controlling Unload function

Keyword	Acceptable values	Default	Description
DECOMPRESS	YES or NO	NO	Specifies whether to decompress compressed segments. See <a href="#">“DECOMPRESS control statement”</a> on page 372.

Table 24. Control statements used for controlling Unload function (continued)

Keyword	Acceptable values	Default	Description
OUTPUT	(See <a href="#">“OUTPUT control statement”</a> on page 375.)	SYSUT2,*HD	<p>Specifies the characteristics of the output data sets to be created and the optional user exit routine for the output.</p> <p>The default DD name SYSUT2 has a special meaning; the data written into SYSUT2 is passed to the Reload task. For DD name SYSUT2, only the *HD unload record format is allowed.</p> <p>If UNLOADONLY=YES is specified in the (REORG) block, the default DD name is DFSURGU1. SYSUT<math>n</math> (<math>n=2,3,4</math>) is not supported.</p> <p>If CRUNLOAD=COND or CRUNLOAD=ALWAYS is specified in the (REORG) block, the default DD name is DFSURGU1. SYSUT<math>n</math> (<math>n=3,4</math>) is not supported.</p> <p>See <a href="#">“OUTPUT control statement”</a> on page 375.</p>
PROGMON	0 - 999999	0	<p>Specifies whether to monitor the progress of the Unload task.</p> <p>See <a href="#">“PROGMON control statement”</a> on page 384.</p>
RAPCHECK	YES or NO	NO	<p>Specifies to check whether each root segment of HDAM/PHDAM database is chained off from the correct RAP.</p> <p>See <a href="#">“RAPCHECK control statement”</a> on page 385.</p>
SEGSEL	( <i>segma</i> ,..., <i>segmz</i> ) or *ALL	*ALL	<p>Specifies the names of the segments to be unloaded selectively. See <a href="#">“SEGSEL control statement”</a> on page 385.</p>

The following table shows the control statements that are applied to the additional unload data sets when SYSUT3 or SYSUT4 is specified for the OUTPUT control statement.



Table 25. Control statements used for additional unload data sets

Keyword	Acceptable values	Default	Description
CHECKREC	YES or NO	NO	Specifies whether the check record used by the IPR Reload utility is added to the unload data set. See <a href="#">“CHECKREC control statement”</a> on page 370.
USERHDR	(elem1,...,elemN)		Specifies the list of the elements in the header portion of the *UH unload format record. For example:  <pre>OUTPUT=SYSUT3,*UH USERHDR=(HDRLN,SEGNAME, ROOTKEY)</pre> See <a href="#">“USERHDR control statement”</a> on page 387.

The control statements for HSSR Engine can be specified for the Unload task. The statements listed in the following table are allowed.

The following table shows control statements used to control HSSR Engine.

Table 26. Control statements used for controlling HSSR Engine

Keyword	Acceptable values	Default	Description
BLDLPCK	YES or NO	NO	Specifies whether to retrieve logical parent's concatenated keys (LPCKs). See <a href="#">“BLDLPCK control statement”</a> on page 392.
BUFFERS	(See <a href="#">“BUFFERS control statement”</a> on page 392.)	*ALL,,8,,100, YES,YES	Change the buffering options for tuning. See <a href="#">“BUFFERS control statement”</a> on page 392.
BUFSTAT	YES or NO	NO	Specifies whether to produce buffering statistics. See <a href="#">“BUFSTAT control statement”</a> on page 395.
BYINDEX	YES or NO	NO	Specifies whether to retrieve HIDAM root segments through the HIDAM index. See <a href="#">“BYINDEX control statement”</a> on page 395.
CABBASE	(See <a href="#">“CABBASE control statement”</a> on page 396.)	(No default)	Specifies the basic buffer size for CAB. See <a href="#">“CABBASE control statement”</a> on page 396.

Table 26. Control statements used for controlling HSSR Engine (continued)

Keyword	Acceptable values	Default	Description
COMPAUTH	YES or NO	NO	Specifies whether to call the segment compression exit in supervisor state. See <a href="#">“COMPAUTH control statement” on page 398.</a>
DBSTATS	(See <a href="#">“DBSTATS control statement” on page 398.</a> )	NO	Specifies whether to produce database statistics. See <a href="#">“DBSTATS control statement” on page 398.</a>
DIAGG	(See <a href="#">“DIAGG control statement” on page 399.</a> )	NO	Specifies whether to generate diagnosis information for status code GG. See <a href="#">“DIAGG control statement” on page 399.</a>
KEYCHECK	NO ABEND GG GX	NO	Specifies whether to check the sequence of sequenced keys. See <a href="#">“KEYCHECK control statement” on page 400.</a>
PARTSTAT	YES or NO	NO	Specifies whether to print statistics report for each HALDB partition. See <a href="#">“PARTSTAT control statement” on page 401.</a>
SKIPERROR	0 - 999999999	0	Specifies the number of errors to skip. See <a href="#">“SKIPERROR control statement” on page 402.</a>
TRACE	(See <a href="#">“TRACE control statement” on page 403.</a> )	(No default)	Specifies whether to generate the trace report. See <a href="#">“TRACE control statement” on page 403.</a>
RTEXT	<i>exitname</i>	HPSURTEX	Specifies the name of the runtime exit routine. See <a href="#">“RTEXT control statement” on page 402.</a>

For the description of each statement, see [“Control statements for HSSR Engine” on page 389.](#)

## Control statements for the Reload task

The control statement block for the Reload task contains the user specifications for controlling the reload process.

**Note:** If REORGINPUT=ULDS is specified, see [“REORGINPUT control statement” on page 155](#) instead of this topic.

Do not specify the COMPRESS and DATXEXIT control statements. The PARTINIT control statement is always ignored, even for HALDBs. However, a HALDB partition to which no segment was reloaded, is

initialized regardless of the PARTITION INIT NEEDED flag in the DBRC registration. The DBRECDIST, RAPCHAIN, and PARTINFO control statements cannot be specified, and because the Reload task does not recognize keywords DBRECDIST, RAPCHAIN, and PARTINFO as control statements, these keywords do not show in the HPSIN Control Statements report (of the Reload task).

In parallel reorganization, DD name DFSUINPT specified in the INPUT control statement has a special meaning; the input identified by the DD name DFSUINPT is passed from Unload task directly.

**Tip:** If you specify PSINDEXBLD=NO in the (REORG) block, indexes are not rebuilt in the job. Therefore, you must rebuild them in a separate index building utility job. However, if you specify the WFPHLQ control statement in the (RELOAD) block, the IPR Reload utility generates WFP work data sets, which can be used as input to IMS Index Builder jobs to rebuild indexes without scanning the databases. You can also specify WFPSPACE, WFPUNIT, WFPVOL, and WFPVOLCNT control statements to set attributes for dynamic allocation of WFP data sets.

The following table shows the control statements you can specify for the Reload task.

Table 27. Control statements for the Reload task

Keyword	Acceptable values	Default	Description
BMSETDSG	<i>n</i> or ( <i>n1</i> , ..., <i>n10</i> ) <i>n=value</i> or *	*	Specifies the threshold value that is used to set the bitmap block. See <a href="#">“BMSETDSG control statement” on page 509.</a>
BUFFERNO	5 - 32767	(None)	Specifies the number of database buffers that are used for one database data set group when reading or writing the database. See <a href="#">“BUFFERNO control statement” on page 510.</a>
BYTELIMIT	DBD NOLIMIT <i>nnnnnnnn</i>	DBD	Specifies the maximum number of bytes for a database record that can be inserted into the root addressable area. See <a href="#">“BYTELIMIT control statement” on page 510.</a>
COMPAUTH	YES or NO	NO	Specifies whether to call the segment compression exit in supervisor state. See <a href="#">“COMPAUTH control statement” on page 512.</a>
DBDSNAP	YES or NO	NO	Generates the DBD Snap report. See <a href="#">“DBDSNAP control statement” on page 514.</a>
DBIOBUF	1 - 999	30 (for VSAM), 15 (for OSAM)	Sets the number of VSAM/OSAM buffers. See <a href="#">“DBIOBUF control statement” on page 514.</a>

Table 27. Control statements for the Reload task (continued)

Keyword	Acceptable values	Default	Description
DBRLBUF	1 - 999	45	Specifies the amount (the number of tracks) of database buffers that are used for one database data set group when reading or writing the database. See <a href="#">“DBRLBUF control statement”</a> on page 516.
EXTENT	1 - 120	120	Specifies the maximum number of extensions of the OSAM data set that can be created. See <a href="#">“EXTENT control statement”</a> on page 516.
FRSPC	YES or NO	YES	Specifies whether to secure free space factors or not. See <a href="#">“FRSPC control statement”</a> on page 517.
ILEDATAC	<i>data_class_name</i>	(none)	Specifies the data class (DATACLAS) for HPSRILEA and HPSRILEB data sets. See <a href="#">“ILEDATAC control statement”</a> on page 519.
ILESTORC	<i>storage_class_name</i>	(none)	Specifies the storage class (STORCLAS) for HPSRILEA and HPSRILEB data sets. See <a href="#">“ILESTORC control statement”</a> on page 519.
INPUT	DFSUINPT, <i>exitname</i> , <i>lang</i>	DFSUINPT	Specifies the input data set, the user exit routine, and its type of language environment. In parallel reorganization, input data is passed from the Unload task directly. You do not need to code DFSUINPT DD in the JCL. See <a href="#">“INPUT control statement”</a> on page 520.
OADSPR	YES or NO	NO	Specifies whether to reduce the usage of data space in processing (P)HDAM overflow area. See <a href="#">“OADSPR control statement”</a> on page 523.

Table 27. Control statements for the Reload task (continued)

Keyword	Acceptable values	Default	Description
PAD	X'00' - X'FF'	X'00'	Specifies the padding character to fill out the segments to adjust to the length that is defined in the DBD definition. See <a href="#">“PAD control statement”</a> on page 523.
PARTSTAT	YES or NO	NO	Specifies whether to print the Segment Count Summary report for each HALDB partition.
PROGMON	0 - 999999	0	Monitors the progress of the Reload task. See <a href="#">“PROGMON control statement”</a> on page 525.
RAAFORMAT	YES or NO	YES	Specifies whether to format the HDAM RAA or not. See <a href="#">“RAAFORMAT control statement”</a> on page 525.
RECNUM	<i>nnnnnnnnn</i>	(none)	Specifies the number of unload records to reload. See <a href="#">“RECNUM control statement”</a> on page 526.
REPAIRILK	NO or YES	NO	Specifies whether to reassign indirect list keys (ILKs). In reassigning ILKs, the IPR Reload utility uses new RBA, partition ID, and reorganization number. See <a href="#">“REPAIRILK control statement”</a> on page 526.
SEARCH	integer value between -999 and 999, both inclusive	3	Sets the space search boundary. See <a href="#">“SEARCH control statement”</a> on page 527.
SEQERROR	ABEND SAVE ACCEPT	ABEND	Specifies how to handle key sequence errors. See <a href="#">“SEQERROR control statement”</a> on page 527.
SORT	YES NO COND	NO	Specifies whether to run physical sequential sort before the reload process. See <a href="#">“SORT control statement”</a> on page 528.

Table 27. Control statements for the Reload task (continued)

<b>Keyword</b>	<b>Acceptable values</b>	<b>Default</b>	<b>Description</b>
SORTHIDAM	YES or NO	NO	Specifies whether to run the root key sequential sort process before loading HIDAM or PHIDAM. See <a href="#">“SORTHIDAM control statement”</a> on page 530.
TWINSTAT	YES or NO	NO	Prints statistics about the twin chained segments in the Segment Statistics report. See <a href="#">“TWINSTAT control statement”</a> on page 530.
WF1REC	YES or NO	YES	Specifies whether to create WF1 records that are written to the DFSURWF1 output work data set. See <a href="#">“WF1REC control statement”</a> on page 533.
WFPHLQ	<i>hlq</i>	(none)	Specifies the high-level qualifier for WFP data sets. See <a href="#">“WFPHLQ control statement”</a> on page 534.
WFPSPACE	CYL or TRK, <i>primary_alloc,secondary_a lloc</i>	(none)	Specifies the SPACE parameter for WFP data sets when allocating WFP data sets dynamically. See <a href="#">“WFPSPACE control statement”</a> on page 535.
WFPUNIT	<i>unit_name</i>	SYSALLDA	Specifies the device for WFP data sets when allocating WFP data sets dynamically. See <a href="#">“WFPUNIT control statement”</a> on page 535.
WFPVOL	<i>volume_name</i> or *	(none)	Specifies the volume names for WFP data sets when allocating WFP data sets dynamically. See <a href="#">“WFPVOL control statement”</a> on page 535.
WFPVOLCNT	<i>nnn</i>	(none)	Specifies the volume count for WFP data sets when allocating WFP data sets dynamically. See <a href="#">“WFPVOLCNT control statement”</a> on page 536.

Table 27. Control statements for the Reload task (continued)

Keyword	Acceptable values	Default	Description
---------	-------------------	---------	-------------

**Note:** DBRLBUF and BUFFERNO are mutually exclusive.

## Control statements for the Index Builder task

The control statement block for the Index Builder task contains the user specifications for controlling the index building process.

The following table shows the control statements that you can specify for the Index Builder task. You cannot specify any control statements other than those listed in the following table.

For details about the control statements of IMS Index Builder and their default values, see the *IMS Index Builder 3.1 User's Guide*.

Table 28. Control statements for the Index Builder task

Keyword	Acceptable values	Corresponding control statement in IMS Index Builder	Description
CLASS	<i>qualifier</i> [.%TIME]	CLASS <i>qualifier</i> [ .%TIME ]	Specifies the high-level qualifier of the stripe data sets that are generated by IMS Index Builder.  Without the %TIME parameter, the maximum length is 17 characters.  If you specify the %TIME parameter, the maximum length is 14 characters including .%TIME.
MAXTASKS	<i>nn</i> [ ,PSORT ]	MAXTASKS <i>nn</i> [ ,PSORT ]	Specifies the number of subordinate address spaces (SASs).  For non-HALDBs, you can specify only MAXTASKS=0. (See <a href="#">Note</a> )  For HALDBs, specify a value for <i>nn</i> in the range of 2 - 36. You can also specify the PSORT keyword.
SIDXBUF	<i>nnn,nnn</i> ( <i>nnn</i> = 1 - 255)	SIDXBUF <i>nnn,nnn</i>	Specifies the number of VSAM buffers that are used in the load process for each secondary index.
SORTFILSZ	<i>nnnnnnnnnn</i>	SORTOPT FILSZ= <i>nnnnnnnnnn</i>	Specifies the FILSZ parameter for the SORT OPTION statement.
SORTFSZ	<i>nnnnnnnnnn</i>	SORTFSZ= <i>nnnnnnnnnn</i>	Triggers striped sort mode. The value specifies the size of the sort stripes. This statement is valid only for HALDBs.
SORTMAINSIZE	<i>nnnnnnnnnn</i>	SORTOPT MAINSIZE= <i>nnnnnnnnnn</i>	Specifies the MAINSIZE parameter for the SORT OPTION statement.

Table 28. Control statements for the Index Builder task (continued)

Keyword	Acceptable values	Corresponding control statement in IMS Index Builder	Description
SORTOPT	(option1,option2,...)	SORTOPT option1,option2,...	Specifies SORT parameters to be appended to the SORT OPTION statement.  Parameters must be separated by commas and enclosed in parentheses. The maximum length of the string inside the parentheses is 33 characters.  If SORTFILSZ or SORTMAINSIZE is specified with SORTOPT, the option strings are concatenated, and the total length must be 33 characters or fewer.
SVCDUMP	YES or NO	SVCDUMP YES or NO	Specifies whether IMS Index Builder requests an SVC dump file after a system abend or a user abend.
TMRWAIT	nnnn (nnnn= 0 - 9999)	TMRWAIT nnnn	Specifies the timeout value in seconds. If you specify 0, timeout does not occur.

**Note:** IMS Index Builder 3.1 (with APAR PM17738) or later supports MAXTASKS=0 control statement when all of the following conditions are met:

- The database is a non-HALDB.
- Type-A physical image copy is not requested for secondary indexes.
- HASH pointer check is not requested in the Index Builder task.

**Restriction:** The following control statements, which were supported in IMS Index Builder 2.3, are not supported in IMS Index Builder 3.1:

- ALTER
- CATLG
- EXEC
- NDXIOBUF
- SORTE35
- SORTSTAT
- SORTID
- SORTOUT
- STEPLIB
- TRACE

## Control statements for the Prefix Resolution task

The control statement block for the Prefix Resolution task contains the user specifications for controlling the prefix update and resolution process.

The following table shows the control statements that you can specify in the (PREFIXRES) block for the Prefix Resolution task. For details about the control statements, see the *IMS High Performance Prefix Resolution User's Guide*.



Table 29. Control statements for the Prefix Resolution task

Keyword	Acceptable values	Default	Description
ALLOWLC	YES or NO	NO	Specifies whether to allow logical children with no logical parent.
ALLOWLP	YES or NO	YES	Specifies whether to allow logical parents with no logical child.
AVGLEN	1 - 999	No default	Specifies the estimated average length of logical pointer records that are created by Reload task.
FILSZ	1 - 999999999	No default	Specifies the estimated number of logical pointer records that are created by Reload task.
HPPRBH	YES or NO	YES	Specifies whether to use the HPPR buffer handler to update the OSAM data sets.
OPRTL	YES or NO	YES	Specifies whether to print orphan logical children.
OPRTL	YES or NO	NO	Specifies whether to print orphan logical parents.
UPDLPC	YES or NO	YES	Specifies whether to update counter fields in logical parents.

## Control statements for the Image Copy task

The control statement block for the Image Copy task contains the user specifications for controlling the image copy process.

If IC=YES is specified, the control statements for the Image Copy processing can be coded in the ICEIN data set.

For the control statements and the parameters supported under the Smart Reorg utility, see the *IMS High Performance Image Copy User's Guide*. Also, see the examples that are shown in [“Example 9: Taking an Image Copy while reorganizing a database”](#) on page 188.

If the system default values are suitable for your requirements, you do not need to code the statements except for the allocation information for the image copy data set.

The default values can be changed by creating a GLOBAL site default table (FABJGLB0) for IMS HP Image Copy. If you create a FABJGLB0 module and specify a library that contains the module on the STEPLIB DD, IMS HP Image Copy merges it with the system default values for IMS Database Reorganization Expert. For details about the site default table, see the *IMS High Performance Image Copy User's Guide*.

**Recommendation:** There are no default values for the allocation information of image copy data sets. It is recommended that you define the allocation information of image copy data sets in the GLOBAL site default table or the GLOBAL statement in the ICEIN data set.

The following default control statement rules apply to IMS HP Image Copy when it is run under the Smart Reorg utility:

- The AIC (Parallel Image Copy) control statement is used for all DBDSs.
- The WAIT control statement is inserted into every partition of HALDB.
- The ICOUT=\* parameter is used.
- The UNIT=SYSALLDA parameter is used.
- The HDPC=Y parameter is used.
- The following default values are used for the DBBUF parameter in Type-A Image Copy processing:
  - DBBUF=250 for each data set of HDAM, HIDAM, SHISAM, or HISAM database except for the HIDAM index and the secondary index data set.
  - DBBUF=2000 for the HIDAM index.
  - DBBUF=1 is always used for the secondary index data set without reference to the value in the DBBUF= parameter.

The default values of other parameters of ICEIN control statements except the compression routine (COMPRTN parameter) are the same as those for the stand-alone IMS HP Image Copy.

#### Notes:

- Both IC and AIC control statements can be accepted for Type-A Image Copy, and the same image copy processing is done regardless of which control statement is specified. In Type-B Image Copy, IC and AIC work differently. If IC is specified, the image copy function works in serial mode; if AIC is specified, the image copy function works in parallel mode.
- The WAIT control statement is valid only for Type-B Image Copy. If a WAIT control statement is specified, the image copy control task waits for all subtasks that are activated by the AIC control statements that are coded above the WAIT statement to complete before starting the image copy processes that are identified by the subsequent AIC control statements. If WAIT is specified for Type-A Image Copy, it is ignored.
- The STACK parameter for the image copy stacking feature is valid only when ICTYPE=B.
- If you specify COMP=Y in the site default table or the ICEIN DD statement, the default compression routine under the Smart Reorg utility is FABJCOMP3.

## Hints and tips for specifying control statements

---

The Smart Reorg utility provides control statements that automate the operations and reduce your manual efforts.

Subsections:

- [“How to stop the database automatically” on page 178](#)
- [“How to build secondary indexes within reorganization job step” on page 179](#)
- [“How to take image copies within reorganization job step” on page 179](#)
- [“How to automate name swapping” on page 179](#)
- [“How to automate DBRC notification processing” on page 179](#)
- [“How to process a database that has logical relationships” on page 179](#)
- [“How to restart the database automatically” on page 180](#)
- [“When processing HALDB partitions” on page 180](#)

### How to stop the database automatically

When you run a Smart Reorg job in Conditional Reorganization mode, in Reorganization Diagnosis mode, or in Unconditional Reorganization mode, you must take the database offline or put it in read-only mode before you run the job. You can specify the Reorganization Manager of the Parallel Reorganization Service to take the database offline automatically by specifying either of the following options in the JCL:

- IMSCMD=YES

If you specify IMSCMD=YES,TOSI, the /DBD or the /DBR command is issued by IMS Database Reorganization Expert automatically. For details, see [“IMSCMD control statement” on page 140](#).

- DBRCAUTHCMD=YES

If you specify DBRCAUTHCMD=YES, the CHANGE.DB NOAUTH or the CHANGE.DB READON command is issued by IMS Database Reorganization Expert automatically. For details, see [“DBRCAUTHCMD control statement” on page 131](#).

In both cases, by default, the Smart Reorg job is stopped if IMS Database Reorganization Expert fails to get the required authorization by issuing the IMS command. If you want IMS Database Reorganization Expert to obtain an operator's response, specify AUTHFAIL=WTOR.

**Note:** If you specify AUTHFAIL=WTOR and you have not issued the /DBDUMP or the /DBRECOVERY command, IMS Database Reorganization Expert issues an operator message that notifies which command must be issued to which database.

## How to build secondary indexes within reorganization job step

To build secondary indexes during a reorganization, specify the INDEXBLD=YES control statement. If INDEXBLD=YES, DASD space for the output secondary index data sets must also be allocated in the IDCAMS step. For more information, see [“INDEXBLD control statement” on page 143](#). For partitioned secondary indexes, specify PSINDEXBLD=YES. For more information, see [“PSINDEXBLD control statement” on page 153](#).

## How to take image copies within reorganization job step

You can specify IC=YES so that the image copy processing can be completed within the Smart Reorg job step. Control statements for Image Copy processing and HASH pointer checking must be specified in the ICEIN data set.

For details, see the following topics:

- [“IC control statement” on page 138](#)
- [“Control statements for the Image Copy task” on page 177](#)
- [“Considerations for Image Copy processing” on page 110](#)
- [“Considerations for HASH pointer checking” on page 114](#)

## How to automate name swapping

The name swapping processing swaps the names of the shadow database and the original database after a successful reorganization. This is one of the post-reorganization processing steps. You can automate this step by specifying NAMESWAP=YES. For more information, see [“NAMESWAP control statement” on page 147](#).

You can also select the action that the Smart Reorg utility takes in case name swapping failure occurs by specifying the NAMESWAPFAIL control statement. For more information, see [“NAMESWAPFAIL control statement” on page 148](#).

## How to automate DBRC notification processing

The DBRC notification processing notifies DBRC about the reorganization. This step is one of the post-reorganization processing steps. You can automate this step by specifying NAMESWAP=YES. For details, see [“NAMESWAP control statement” on page 147](#).

## How to process a database that has logical relationships

For a database that has logical relationships, you must run the IMS Prefix Resolution and Prefix Update utilities after the Smart Reorg job step.

The following guidelines describe how to run the post-reorganization processing automatically:

- For a HISAM, HDAM, or HIDAM database that has no secondary indexes and no logical relationships, specify NAMESWAP=YES.
- For a HISAM, HDAM, or HIDAM database that has secondary indexes, specify INDEXBLD=YES and NAMESWAP=YES.
- For an HDAM or HIDAM database that has only internal logical relationships, specify PREFIXRES=YES and NAMESWAP=YES.
- For a PHDAM or PHIDAM database, specify ILDSBLD=YES, which is the default, and specify NAMESWAP=YES.

For details, see the following topics:

- [“NAMESWAP control statement” on page 147](#)
- [“PREFIXRES control statement” on page 153](#)
- [“Considerations for logical relationships” on page 109](#)

## How to restart the database automatically

After a database is reorganized, you must start the database to make it active. You can automate this step by specifying the STARTDB=YES option. For details, see [“STARTDB control statement” on page 158](#).

## When processing HALDB partitions

### Specifying the target partition

You must specify the name of the partition and the number of partitions to reorganize by coding the PARTITION control statement. For details, see [“PARTITION control statement” on page 150](#).

### Building ILDS within reorganization job step

To build indirect list data sets (ILDS) for one or more HALDB partitions during the reorganization, specify the ILDSBLD=YES control statement. If ILDSBLD=NO is specified, a DASD space for the shadow ILDS must be allocated for each partition. For details, see [“ILDSBLD control statement” on page 139](#).

**Requirement:** You must do these tasks manually if any automatic processing fails.

### Related tasks

#### [Pre-reorganization processing](#)

You must perform pre-reorganization processing before you run a Smart Reorg utility job except when you run the job in Diagnosis-only mode.

#### [Post-reorganization processing](#)

You must perform post-reorganization processing after a Smart Reorg utility job when a reorganization has been committed.

---

## Chapter 10. Smart Reorg examples

The following topics provide examples for using the Smart Reorg utility.

### Topics:

- [“Example 1: Generating the Diagnosis report without reorganizing the database” on page 181](#)
- [“Example 2: Conditionally reorganizing a database” on page 182](#)
- [“Example 3: Reorganizing a database and generating the Diagnosis report” on page 184](#)
- [“Example 4: Reorganizing a database without rebuilding indexes” on page 184](#)
- [“Example 5: Reorganizing a database and its secondary indexes” on page 185](#)
- [“Example 6: Reorganizing a database while allowing read access” on page 186](#)
- [“Example 7: Reorganizing logically related databases” on page 187](#)
- [“Example 8: Reorganizing a HALDB partition” on page 187](#)
- [“Example 9: Taking an Image Copy while reorganizing a database” on page 188](#)
- [“Example 10: Reorganizing and starting a database and indexes” on page 195](#)
- [“Example 11: Reloading a database and taking an image copy” on page 196](#)
- [“Example 12: Performing manual post-processing after a Smart Reorg utility job” on page 197](#)
- [“Example 13: Reorganizing a HALDB database and rebuilding PSINDEXes” on page 198](#)
- [“Example 14: Conditional reorganization based on the number of days since the last reorganization” on page 199](#)
- [“Example 15: Reorganizing a database when the IMS management of ACBs is enabled” on page 201](#)
- [“Example 16: Conditionally reorganizing a database in separate job steps” on page 202](#)

### Example 1: Generating the Diagnosis report without reorganizing the database

---

This JCL example is for generating the Database Diagnosis report. The job runs in Diagnosis-only mode. In this mode, the Conditional Reorganization Support Service is called but the database is not reorganized in any cases.

In the following JCL example:

- The reorganization process is not run even when database reorganization is required because CONDREORG=YES,DIAGONLY is specified in the (REORG) block.
- The Diagnosis report is generated because PRINTRPRT=YES is specified in the (CONDREORG) block.
- The Diagnosis report is stored in the Output repository of IMS Tools KB because STORERPRT=YES is specified in the (CONDREORG) block.

**Tip:** If you want to see journal messages that are issued by CRSS components, specify JOURNAL=YES in the (CONDREORG) block.

```

//DBDIAG EXEC PGM=HPSGMAIN,PARM='DBD=SAMPLEDB,DBRC=Y'
//STEPLIB DD DISP=SHR,DSN=IMSTOOLS.SHPSLMD0
// DD DISP=SHR,DSN=IMSTOOLS.SHKTLOAD /* ITKB, Policy Services */
// DD DISP=SHR,DSN=IMS.SDFSRESL
// DD DISP=SHR,DSN=USER.PGMLIB
//IMSDALIB DD DISP=SHR,DSN=IMS.MDALIB
//IMS DD DISP=SHR,DSN=IMS.DBDLIB
//HPSIN DD *
(REORG)
CONDREORG=YES,DIAGONLY
ITKBSRVR=FPQSVR00
(CONDREORG)
POLICYBY=DBTYPE
PRINTRPRT=YES
STORERPRT=YES
/*

```

Figure 15. Generating a Diagnosis report

## Example 2: Conditionally reorganizing a database

The following JCL examples are for running conditional reorganization jobs.

Subsections:

- [“Selecting a policy by database type” on page 182](#)
- [“Selecting a policy by DBD name” on page 182](#)
- [“Selecting a policy by policy name” on page 183](#)

### Selecting a policy by database type

The following JCL example is for selecting the reorganization policy by database type.

```

//CREORG EXEC PGM=HPSGMAIN,PARM='DBD=SAMPLEDB,DBRC=Y'
//STEPLIB DD DISP=SHR,DSN=IMSTOOLS.SHPSLMD0
// DD DISP=SHR,DSN=IMSTOOLS.SHKTLOAD /* ITKB, Policy Services */
// DD DISP=SHR,DSN=IMS.SDFSRESL
// DD DISP=SHR,DSN=USER.PGMLIB
//IMSDALIB DD DISP=SHR,DSN=IMS.MDALIB
//IMS DD DISP=SHR,DSN=IMS.DBDLIB
//HPSIN DD *
(REORG)
CONDREORG=YES
ITKBSRVR=FPQSVR00
SPACEALLOC=YES
NAMESWAP=YES
(CONDREORG)
POLICYBY=DBTYPE
/*

```

Figure 16. Selecting policy by database type—conditional reorganization job

### Selecting a policy by DBD name

The following JCL example is for selecting the reorganization policy based on the DBD name.

```

//CREORG EXEC PGM=HPSGMAIN,PARM='DBD=SAMPLEDB,DBRC=Y'
//STEPLIB DD DISP=SHR,DSN=IMSTOOLS.SHPSLMD0
// DD DISP=SHR,DSN=IMSTOOLS.SFOILOAD /* TOSI */
// DD DISP=SHR,DSN=IMSTOOLS.SHKTLOAD /* ITKB, Policy Services */
// DD DISP=SHR,DSN=IMS.SDFSRESL
// DD DISP=SHR,DSN=USER.PGMLIB
//IMSDALIB DD DISP=SHR,DSN=IMS.MDALIB
//IMS DD DISP=SHR,DSN=IMS.DBDLIB
//HPSIN DD *
(REORG)
  CONDREORG=YES /* USE CRSS */
  ITKBSRVR=FPQSVR00 /* USE ITKB */
  SPACEALLOC=YES
  IMSCMD=YES,TOSI /* USE TOSI */
  TOSIXCFGRP=REORG
  DBSHARE=YES
  STARTDB=YES
  INDEXBLD=YES /* USE IB */
  IC=YES /* USE HPIC */
  NAMESWAP=YES
(CONDREORG)
  POLICYBY=DBDNAME
  JOURNAL=YES
  DBS_HPIO=YES
/*
//ICEIN DD *
GLOBAL HDPC=Y, /* USE HPPC */
        ICHLQ=IMSICA,
        DSN=&ICHLQ..&DDN..IC1,
        UNIT=SYSALLDA
/*

```

Figure 17. Selecting policy by DBD name—conditional reorganization job

## Selecting a policy by policy name

The following JCL example is for selecting the reorganization policy based on the policy name.

```

//CREORG EXEC PGM=HPSGMAIN,PARM='DBD=SAMPLEDB,DBRC=Y'
//STEPLIB DD DISP=SHR,DSN=IMSTOOLS.SHPSLMD0
// DD DISP=SHR,DSN=IMSTOOLS.SIIULMOD /* IB */
// DD DISP=SHR,DSN=IMSTOOLS.SFOILOAD /* TOSI */
// DD DISP=SHR,DSN=IMSTOOLS.SHKTLOAD /* ITKB, Policy Services */
// DD DISP=SHR,DSN=IMS.SDFSRESL
// DD DISP=SHR,DSN=USER.PGMLIB
//DFSRESLB DD DISP=SHR,DSN=IMS.SDFSRESL
//IMSDALIB DD DISP=SHR,DSN=IMS.MDALIB
//IMS DD DISP=SHR,DSN=IMS.DBDLIB
//HPSIN DD *
(REORG)
  CONDREORG=YES /* USE REORG EXPERT */
  ITKBSRVR=FPQSVR00 /* USE ITKB */
  SPACEALLOC=YES
  IMSCMD=YES,TOSI /* USE TOSI */
  TOSIXCFGRP=REORG
  DBSHARE=YES
  INDEXBLD=YES /* USE IB */
  IC=YES /* USE HPIC */
  NAMESWAP=YES
  STARTDB=YES
(CONDREORG)
  POLICYBY=NAME
  POLICYNM=USER.HDAM.VSAM.POL01
  JOURNAL=YES
  DBS_HPIO=YES
/*
//ICEIN DD *
GLOBAL HDPC=Y, /* USE HPPC */
        ICHLQ=IMSICA,
        DSN=&ICHLQ..&DDN..IC1,
        UNIT=SYSALLDA
/*

```

Figure 18. Selecting policy by policy name—conditional reorganization job

## Example 3: Reorganizing a database and generating the Diagnosis report

This JCL example is for reorganizing a database and generating the Database Diagnosis report. The job runs in Reorganization Diagnosis mode. In this mode, the database is always reorganized and the Conditional Reorganization Support Service is called to generate the Database Diagnosis report.

In the following JCL example:

- The reorganization process is run regardless of the database status because CONDREORG=YES, REORGDIAG is specified in the (REORG) block.
- The Diagnosis report is generated because PRINTRPRT=YES is specified in the (CONDREORG) block.
- The Diagnosis report is stored in the Output repository of IMS Tools KB because STORERPRT=YES is specified in the (CONDREORG) block.

**Tip:** If you want to see journal messages that are issued by CRSS components, specify JOURNAL=YES in the (CONDREORG) block.

```
//REORGD EXEC PGM=HPSGMAIN, PARM='DBD=SAMPLEDB, DBRC=Y'  
//STEPLIB DD DISP=SHR, DSN=IMSTOOLS.SHPSLMD0  
// DD DISP=SHR, DSN=IMSTOOLS.SHKTLOAD /* ITKB, Policy Services */  
// DD DISP=SHR, DSN=IMS.SDFSRESL  
// DD DISP=SHR, DSN=USER.PGMLIB  
//IMSDALIB DD DISP=SHR, DSN=IMS.MDALIB  
//IMS DD DISP=SHR, DSN=IMS.DBDLIB  
//HPSIN DD *  
(REORG)  
CONDREORG=YES, REORGDIAG  
ITKBSRVR=FPQSVR00  
SPACEALLOC=YES  
NAMESWAP=YES  
(CONDREORG)  
POLICYBY=DBTYPE  
PRINTRPRT=YES  
STORERPRT=YES  
/*
```

Figure 19. Reorganizing a database and generating the Diagnosis report

## Example 4: Reorganizing a database without rebuilding indexes

In this example, the database to be reorganized is a HIDAM database that has no secondary index and no logical relationship.

JCL statements shown in the following figure show two steps involved in parallel reorganization of a HIDAM database. The first step allocates the shadow data sets, and the second step reorganizes the database. HPSIN DD in the second step shows that the control statements for Reorganization Manager are specified in the (REORG) block.



```

//ALLOC EXEC PGM=IDCAMS
//SYSPRINT DD SYSOUT=*
//SYSIN DD *
DELETE original.database.dataset.name.A
DELETE original.database.dataset.name.T
SET MAXCC=0
DEFINE CLUSTER(NAME(original.database.dataset.name.A) -
               ..... ) -
        DATA(NAME(original.database.dataset.name.DATA.A))
DEFINE CLUSTER(NAME(original.primary.index.dataset.name.A) -
               ..... ) -
        DATA(NAME(original.primary.index.dataset.name.DATA.A))
/*
//REORG EXEC PGM=HPSGMAIN, PARM=' DBD=dbdname, DBRC=Y'
//STEPLIB DD DISP=SHR, DSN=IMSTOOLS.SHPSLMD0
//        DD DISP=SHR, DSN=IMS.SDFSRESL
//IMS     DD DISP=SHR, DSN=IMS.DBDLIB
//HPSIN   DD *
(REORG)
        NAMESWAP=YES
        AUTHFAIL=WTOR
        DYNALLOC=YES,A
/*

```

Figure 20. Reorganizing a database that has no secondary index or logical relationship

You must issue a /DBR command before submitting the JCL because IMSCMD=YES is not specified and DBSHARE=YES is not specified. Because AUTHFAIL=WTOR is specified, a message is issued to tell the operator to issue the /DBR command for the database if the command was not issued in advance. For details, see [“Hints and tips for specifying control statements” on page 178](#).

All input and shadow database data sets are allocated dynamically; the shadow data set names have the suffix .A appended at the end of the original data set names because DYNALLOC=YES,A is specified (see [“DYNALLOC control statement” on page 136](#)). DD names for the shadow data sets are determined by the default mapping pattern (see [“DDNMAP control statement” on page 133](#)). For details of DD names and data set names for input and shadow data sets, see [“Considerations for database data sets” on page 104](#).

Automated post-reorganization processing, including data set name swapping, is done because NAMESWAP=YES is specified. If NAMESWAP=YES is not specified, you must do the post-reorganization processing manually. For details, see [“Post-reorganization processing” on page 212](#).

See the *Access Method Services Reference* for details on IDCAMS commands and allocation of output data sets.

## Example 5: Reorganizing a database and its secondary indexes

In this example, the database to be reorganized is an HDAM database that has two secondary indexes but has no logical relationship.

**Note:** For an example to reorganize a HALDB that has partitioned secondary indexes, see [“Example 13: Reorganizing a HALDB database and rebuilding PSINDEXes” on page 198](#).

JCL statements shown in the following figure show two steps involved in parallel reorganization of an HDAM database. The first step allocates the shadow data sets and the data sets to which the secondary indexes are built, and the second step reorganizes the database and builds the secondary indexes. The HPSIN DD statement in the second step shows that the control statements for Reorganization Manager are specified in the (REORG) block.

```

//ALLOC EXEC PGM=IDCAMS
//SYSPRINT DD SYSOUT=*
//SYSIN DD *
DELETE original.database.dataset.name.Z CLUSTER PURGE
DELETE original.index1.dataset.name.Z CLUSTER PURGE
DELETE original.index2.dataset.name.Z CLUSTER PURGE
DELETE original.database.dataset.name.T CLUSTER PURGE
DELETE original.index1.dataset.name.T CLUSTER PURGE
DELETE original.index2.dataset.name.T CLUSTER PURGE
SET MAXCC=0
DEFINE CLUSTER(NAME(original.database.dataset.name.Z) -
...
DEFINE CLUSTER(NAME(original.index1.dataset.name.Z) -
...
DEFINE CLUSTER(NAME(original.index2.dataset.name.Z) -
...
/*
//REORG EXEC PGM=HPSGMAIN,PARM='DBD=dbdname,DBRC=Y'
//STEPLIB DD DISP=SHR,DSN=IMSTOOLS.SHPSLMD0
// DD DISP=SHR,DSN=IMSTOOLS.SFOILOAD
// DD DISP=SHR,DSN=IMSTOOLS.SIIULMOD
// DD DISP=SHR,DSN=IMS.SDFSRESL
//IMS DD DISP=SHR,DSN=IMS.DBDLIB
//HPSIN DD *
(REORG)
IMSCMD=YES,TOSI
TOSIXCFGRP=TGRP1
NAMESWAP=YES
INDEXBLD=YES
/*

```

Figure 21. Reorganizing a database that has secondary indexes (DBSHARE=NO)

Reorganization Manager of the Smart Reorg utility issues a /DBR command internally before starting the reorganization because IMSCMD=YES,TOSI is specified and DBSHARE=YES is not specified. You do not need to issue the /DBR command before submitting the JCL stream. If the required authorization is not acquired by the /DBR command, the job is ends abnormally because AUTHFAIL=WTOR is not specified. For details, see [“Hints and tips for specifying control statements” on page 178](#).

All input and shadow database data sets and output secondary index data sets are allocated dynamically; the shadow data set names and the output secondary index data sets have the suffix .Z added at the end of the original data set names because the default DYNALLOC=YES,Z option is used (see [“DYNALLOC control statement” on page 136](#)). DD names for the shadow database data sets are determined by the default mapping pattern ([“DDNMAP control statement” on page 133](#)). For details of DD names and data set names for input and shadow data sets, see [“Considerations for database data sets” on page 104](#).

All secondary indexes for the database are built by Index Builder task because INDEXBLD=YES is specified. The secondary indexes are built into new data sets whose names are formed by adding the suffix .Z at the end of each original data set name. For details about how to specify data sets for secondary indexes, see [“Secondary indexes” on page 106](#).

Automated data set name swapping and DBRC notification are done because NAMESWAP=YES is specified. If NAMESWAP=YES is not specified, you must do the post-reorganization processing manually. For details, see [“Post-reorganization processing” on page 212](#).

If SPACEALLOC=YES,FORCE is added, the ALLOC job step can be eliminated.

## Example 6: Reorganizing a database while allowing read access

In this example, the database to be reorganized is an HDAM database that has two secondary indexes but has no logical relationship.

See the JCL stream in the following figure. The difference between this JCL stream and the one in [Figure 21 on page 186](#) is that DBSHARE=YES and AUTHFAIL=WTOR is specified in this one. Reorganization Manager of the Smart Reorg issues a /DBD command internally before starting the reorganization because IMSCMD=YES,TOSI and DBSHARE=YES are specified. You do not need to issue a /DBD command before submitting the JCL stream. If the required authorization is not acquired by the /DBD command, a message

is issued to request operator actions because AUTHFAIL=WTOR is specified. For details, see [“IMSCMD control statement”](#) on page 140 and [“AUTHFAIL control statement”](#) on page 128.

```
//REORG EXEC PGM=HPSGMAIN, PARM=' DBD=dbdname , DBRC=Y '  
//STEPLIB DD DISP=SHR, DSN=IMSTOOLS.SHPSLMD0  
// DD DISP=SHR, DSN=IMSTOOLS.SFOILOAD  
// DD DISP=SHR, DSN=IMSTOOLS.SIIULMOD  
// DD DISP=SHR, DSN=IMS.SDFSRESL  
//IMS DD DISP=SHR, DSN=IMS.DBDLIB  
//HPSIN DD *  
(REORG)  
IMSCMD=YES, TOSI  
TOSIXCFGRP=TGRP1  
TOSITEST=(100,3)  
AUTHFAIL=WTOR  
SPACEALLOC=YES, FORCE  
DBSHARE=YES  
NAMESWAP=YES  
INDEXBLD=YES  
/*
```

Figure 22. JCL for reorganizing a database that has secondary indexes (DBSHARE=YES)

Automated shadow allocation is done because SPACEALLOC=YES, FORCE is specified. Automated data set name swapping and DBRC notification is done because NAMESWAP=YES is specified. Before data set name swapping starts, Reorganization Manager issues a /DBR command to get exclusive control over the database. If the command fails or the required database authorization is not acquired, a message is issued to request operator actions.

## Example 7: Reorganizing logically related databases

---

The JCL statements for reorganizing a database that has external logical relationship by using the Smart Reorg utility are the same as those used for a database that has no logical relationship except that you must specify DFSURCDS and DFSURWF1 DD statements.

For details, see [“Post-reorganization processing for database with logical relationships”](#) on page 214 and [“Considerations for logical relationships”](#) on page 109.

## Example 8: Reorganizing a HALDB partition

---

This JCL example is for reorganizing a partition of PHIDAM.

The PARTITION control statement specifies the HALDB partition to reorganize. The shadow ILDS and the shadow primary index, as well as the shadow primary database, are defined before the Smart Reorg job step.

```

//REORG   JOB ...
//* -----*
//*      Define shadow database data set          *
//* -----*
//ALLOC   EXEC PGM=IDCAMS
//SYSPRINT DD SYSOUT=*
//SYSIN   DD *
DELETE original.database.dataset.name.Z
DELETE original.ilds.dataset.name.Z
DELETE original.pindex.dataset.name.Z
DELETE original.database.dataset.name.T
DELETE original.ilds.dataset.name.T
DELETE original.pindex.dataset.name.T
SET MAXCC=0
DEFINE CLUSTER(NAME(original.database.dataset.name.Z) -
              ...
              DEFINE CLUSTER(NAME(original.ilds.dataset.name.Z) -
              ...
              DEFINE CLUSTER(NAME(original.pindex.dataset.name.Z) -
              ...
/*
//* -----*
//*      Reorganization                          *
//* -----*
//REORG EXEC PGM=HPSGMAIN,PARM='DBD=dbdname,DBRC=Y,IMSID=IMSA'
//STEPLIB DD DISP=SHR,DSN=IMSTOOLS.SHPSLMD0
//        DD DISP=SHR,DSN=IMSTOOLS.SFOILOAD
//        DD DISP=SHR,DSN=IMS.SDFSRESL
//IMS     DD DISP=SHR,DSN=IMS.DBDLIB
//HPSIN   DD *
(REORG)
IMSCMD=YES,TOSI
TOSIXCFGRP=REORG
TOSITEST=(100,3)
NAMESWAP=YES
AUTHFAIL=ABORT
PARTITION=PARTA
/*

```

Figure 23. Sample JCL stream to reorganize a partition of PHIDAM database

If SPACEALLOC=YES,FORCE is added, the ALLOC job step can be eliminated.

## Example 9: Taking an Image Copy while reorganizing a database

In these topics, the use of the Smart Reorg's control statements for the Image Copy processing is demonstrated by using sample databases.

In the first five examples, the database is a HIDAM database, and the database has secondary indexes in all of the examples except for “[Example 9-1: Type-A Image Copy \(1\)](#)” on page 188. In “[Example 9-2: Type-A Image Copy \(2\)](#)” on page 189, the database has internal logical relationships. In “[Example 9-6: Type-A Image Copy for HALDB partitions](#)” on page 193, the database is a PHIDAM.

### Example 9-1: Type-A Image Copy (1)

In this example, the database to be reorganized is a HIDAM database that has no secondary index and no logical relationships.

In this example:

- The database to be reorganized is a HIDAM
- The database has no secondary index and no logical relationship
- The database is registered to RECON as recoverable
- Type-A Image Copy is selected because the database has no logical relationship

To activate Type-A image copy, you must specify IC=YES in the (REORG) block. You can specify options for IMS HP Image Copy in the ICEIN DD statement. A sample JCL stream is shown in the following figure.

```

//ALLOC    EXEC PGM=IDCAMS
//SYSPRINT DD SYSOUT=A
//SYSIN    DD *
/* DELETE SHADOW DATA SETS */
...
/* ALLOCATE SHADOW DATA SETS */
...
/*
//REORG    EXEC PGM=HPSGMAIN, PARM='DBD=SAMPLEDB,DBRC=Y'
//STEPLIB DD DISP=SHR, DSN=IMSTOOLS.SHPSLMD0
//         DD DISP=SHR, DSN=IMS.SDFSRESL
//IMSDALIB DD DISP=SHR, DSN=IMS.MDALIB
//IMS     DD DISP=SHR, DSN=IMS.DBDLIB
//HPSIN   DD *
(REORG)
DBRCAUTHCMD=YES
NAMESWAP=YES
DELOLDDS=YES
IC=YES
/*
//ICEIN    DD *
GLOBAL    ICHLQ=IMSICA,
          UNIT=SYSALLDA,
          SPACE=(CYL,100,100)
/*

```

Figure 24. Sample JCL stream for Type-A Image Copy (1)

The JCL statements in this example show two job steps involved in the parallel reorganization of the database. In the first step, the shadow data sets are allocated. The second step is the Smart Reorg utility step; in this step, the databases are reorganized, and image copies of the reorganized database data sets are taken.

Because DBRCAUTHCMD=YES is specified in the HPSIN input stream, the CHANGE.DB NOAUTH command is issued internally to prevent authorization for the database during reorganization.

The HDPC and VIC parameters are not coded in the GLOBAL control statement in the ICEIN input stream; the default options HDPC=Y and VIC=N are used unless the site default table module (FABJGLB0) is used. The HDPC=Y option activates HASH pointer checking for all data sets that are reorganized. Image copies of the database data sets and the primary index are taken while the database is being reloaded to shadow data sets.

Because NAMESWAP=YES is specified, data set name swapping and the DBRC notification are done after the reloading and image copying of the shadow data sets have completed successfully. The image copies are registered to RECON through the DBRC NOTIFY.IC commands that are issued internally by the Smart Reorg utility. Because DELOLDDS=YES is coded, original database data sets and original index data set are deleted after successful name swapping and DBRC notification.

## Example 9-2: Type-A Image Copy (2)

In this example, the database to be reorganized is a HIDAM database that has secondary indexes.

In this example:

- The database to be reorganized is a HIDAM
- The database has secondary indexes
- The database has no logical relationship
- The database and all indexes are registered to RECON as recoverable
- Type-A Image Copy is selected because the database has no logical relationship
- The name of each image copy data set is constructed as follows:

```
IMSICA.ICn.dbdname.ddname.Dyyddd.Thhmmss
```

In this case, you can use Type-A Image Copy because the database has no logical relationship. For rebuilding all secondary indexes, you need to add INDEXBLD=YES to the JCL stream shown in the following figure.

```

//ALLOC EXEC PGM=IDCAMS
//SYSPRINT DD SYSOUT=A
//SYSIN DD *
/* DELETE SHADOW DATA SETS */
...
/* ALLOCATE SHADOW DATA SETS */
...
/*
//REORG EXEC PGM=HPSGMAIN, PARM='DBD=SAMPLEDB,DBRC=Y'
//STEPLIB DD DISP=SHR, DSN=IMSTOOLS.SHPSLMD0
// DD DISP=SHR, DSN=IMS.SDFSRESL
//IMSDALIB DD DISP=SHR, DSN=IMS.MDALIB
//IMS DD DISP=SHR, DSN=IMS.DBDLIB
//HPSIN DD *
(REORG)
DBRCAUTHCMD=YES
INDEXBLD=YES
NAMESWAP=YES
DELOLDDS=YES
IC=YES
/*
//ICEIN DD *
GLOBAL ICHLQ=IMSICA,
ICNMRULE=Y,
UNIT=SYSALLDA,
SPACE=(CYL,100,100)
/*

```

Figure 25. Sample JCL stream for Type-A Image Copy (2)

### Example 9-3: Type-A Image Copy (3)

In this example, the database to be reorganized is a HIDAM database. The database has secondary indexes that are registered to DBRC as NONRECOV.

In this example:

- The database to be reorganized is a HIDAM
- The database has secondary indexes
- The database has no logical relationship
- The database is registered to RECON as recoverable
- All indexes, both primary and secondary, are registered to RECON as NONRECOV
- The image copy data sets are dynamically allocated as data sets of generation data set groups. The name of each image copy data set, except for the virtual image copy, is constructed as:

```
IMSICA.dbdname.ddname.GggggVvv
```

When database recovery becomes necessary, it is expected that indexes are rebuilt by using IMS Index Builder after primary database data sets are recovered.

The following figure shows an example JCL stream you can use in such a case.

```

//ALLOC EXEC PGM=IDCAMS
//SYSPRINT DD SYSOUT=A
//SYSIN DD *
/* DELETE SHADOW DATA SETS */
...
/* ALLOCATE SHADOW DATA SETS */
...
/*
//REORG EXEC PGM=HPSGMAIN, PARM='DBD=SAMPLEDB,DBRC=Y'
//STEPLIB DD DISP=SHR, DSN=IMSTOOLS.SHPSLMD0
// DD DISP=SHR, DSN=IMS.SDFSRESL
//IMSDALIB DD DISP=SHR, DSN=IMS.MDALIB
//IMS DD DISP=SHR, DSN=IMS.DBDLIB
//HPSIN DD *
(REORG)
DBRCAUTHCMD=YES
INDEXBLD=YES
NAMESWAP=YES
DELOLDDS=YES
IC=YES
/*
//ICEIN DD *
GLOBAL VIC=Y, VICDSN=A_TEXT_IDENTIFYING_THE_UIC_NOTIFICATION,
ICHLQ=IMSICA,
DSN=&ICHLQ..&DBD..&DDN..&GDG,
UNIT=SYSALLDA,
SPACE=(CYL,100,100)
/*

```

Figure 26. Sample JCL stream for Type-A Image Copy (3)

Parameter VIC=Y specifies that the image copy of indexes not be taken, and NOTIFY.UIC commands be issued for the indexes with the text string that is supplied by the VICDSN parameter being used as the UDATA text of the NOTIFY.UIC command. Because the default for the HDPC parameter is HDPC=Y, HASH pointer checking for the indexes is done while the shadow indexes are being rebuilt.

## Example 9-4: Type-A Image Copy (4)

In this example, the database to be reorganized is a HIDAM database. The database has secondary indexes that are registered to DBRC as NONRECOV and NOICREQ.

In this example:

- The database to be reorganized is a HIDAM
- The database has secondary indexes
- The database has no logical relationship
- The database is registered to RECON as recoverable
- All indexes, both primary and secondary, are registered to RECON as NONRECOV and NOICREQ

When database recovery becomes necessary for such a database, it is expected that the indexes are rebuilt by using IMS Index Builder after primary database data sets are recovered.

The following figure shows an example JCL stream you can use in such a case.

```

//ALLOC EXEC PGM=IDCAMS
//SYSPRINT DD SYSOUT=A
//SYSIN DD *
/* DELETE SHADOW DATA SETS */
...
/* ALLOCATE SHADOW DATA SETS */
...
/*
//REORG EXEC PGM=HPSGMAIN, PARM='DBD=SAMPLEDB,DBRC=Y'
//STEPLIB DD DISP=SHR, DSN=IMSTOOLS.SHPSLMD0
// DD DISP=SHR, DSN=IMS.SDFSRESL
//IMSDALIB DD DISP=SHR, DSN=IMS.MDALIB
//IMS DD DISP=SHR, DSN=IMS.DBDLIB
//HPSIN DD *
(REORG)
DBRCAUTHCMD=YES
INDEXBLD=YES
NAMESWAP=YES
DELOLDDS=YES
IC=YES
/*
//ICEIN DD *
GLOBAL HDPC=0,
        ICHLQ=IMSICA,
        UNIT=SYSALLDA,
        SPACE=(CYL,100,100)
/*

```

Figure 27. Sample JCL stream for Type-A Image Copy (4)

Parameter HDPC=O specifies that HASH pointer checking is done to the indexes while shadow indexes are being rebuilt, but image copies of the indexes are not taken and the NOTIFY.UIC commands are not issued for the indexes.

## Example 9-5: Type-B Image Copy

In this example, the database to be reorganized is a HIDAM database that has internal logical relationships.

In this example:

- The database to be reorganized is a HIDAM
- The database has secondary indexes
- The database has internal logical relationships
- The database and all indexes, both primary and secondary, are registered to RECON as recoverable
- Image copy data sets are sequentially put into two tapes. In this example, all database data sets of DBD=SAMPLEDB are stored in one tape (STK1), and primary index (DBD=SAMPLEPX) and secondary indexes (DBD=SINDEX01 and DBD=SINDEX02) are stored into the other tape (STK2).
- The image copy process for tapes STK1 and STK2 are run in parallel; the image copy process for database data sets within a tape such as STK1 are run sequentially.
- The name of each image copy data set, except for the virtual image copy, is constructed as:

```
IMSICA.ICn.dbdname.ddname.Dyyddd.Thhmmss
```

In this case, you can use Type-B Image Copy only. You must specify ICTYPE=B in the (REORG) block in the HPSIN input stream as shown in [Figure 28 on page 193](#).

You must add one job step before the Smart Reorg utility job step. This job step is to run the IMS Database Preorganization utility for creating the DFSURCDS data set. The DFSURCDS data set must be specified with the DFSURCDS DD statement in the Smart Reorg utility job step.

The DFSURWF1 DD statement must also be specified, and a temporary data set of appropriate size can be allocated by the DD statement.



```

//ALLOC      EXEC PGM=IDCAMS
//SYSPRINT  DD SYSOUT=A
//SYSIN     DD *
/* DELETE SHADOW DATA SETS */
...
/* ALLOCATE SHADOW DATA SETS */
...
/*
//REORG     EXEC PGM=HPSGMAIN, PARM='DBD=SAMPLEDB,DBRC=Y'
//STEPLIB  DD DISP=SHR, DSN=IMSTOOLS.SHPSLMD0
//         DD DISP=SHR, DSN=IMS.SDFSRESL
//IMSDALIB DD DISP=SHR, DSN=IMS.MDALIB
//IMS      DD DISP=SHR, DSN=IMS.DBDLIB
//DFSURCDS DD DISP=SHR, DSN=DFSURCDS
//DFSURWF1 DD DISP=(NEW,PASS,DELETE), DSN=&&DFSURWF1,
//         UNIT=SYSALLDA, SPACE=(CYL,(n,m)),
//         DCB=(RECFM=VB, LRECL=800, BLKSIZE=2400)
//HPSIN    DD *
(REORG)
  DBRCAUTHCMD=YES
  INDEXBLD=YES
  PREFIXRES=YES
  NAMESWAP=YES
  DELOLDDS=YES
  IC=YES
  ICTYPE=B
(PREFIXRES)
  UPDLPC=NO
/*
//ICEIN    DD *
  GLOBAL   HDPC=(Y,MAXFSD),
           ICHLQ=IMSICA,
           UNIT=TAPE
  AIC      DBD=SAMPLEDB, STACK=STK1
  AIC      DBD=SAMPLEPX, STACK=STK2
  AIC      DBD=SINDEX01, STACK=STK2
  AIC      DBD=SINDEX02, STACK=STK2
/*

```

Figure 28. Sample JCL stream for Type-B Image Copy

## Example 9-6: Type-A Image Copy for HALDB partitions

In this example, the database to be reorganized is a PHIDAM database with several partitions.

In this example, PHI00100 is a PHIDAM database that is composed of five partitions: PART1, PART2, PART3, PART4, and PART5. The partition selection sequence that is determined by the high keys or a partition selection exit is in the preceding sequence.

If you want to reorganize PART2 and PART3 and to take image copies of the reorganized partition data sets while the reorganization is being done, you can use the JCL stream that is shown in the following figure.

```

//ALLOC      EXEC PGM=IDCAMS
//SYSPRINT DD SYSOUT=A
//SYSIN      DD *
/* DELETE SHADOW DATA SETS */
...
/* ALLOCATE SHADOW DATA SETS */
...
/*
//REORG      EXEC PGM=HPSGMAIN, PARM=' DBD=PHI00100, DBRC=Y, IRLM=N '
//STEPLIB DD DISP=SHR, DSN=IMSTOOLS.SHPSLMD0
//          DD DISP=SHR, DSN=IMS.SDFSRESL
//IMS       DD DISP=SHR, DSN=IMS.DBDLIB
//HPSIN     DD *
(REORG)
PARTITION=(PART2,2)
IC=YES
DBRCAUTHCMD=YES
NAMESWAP=YES
DELOLDDS=YES
/*
//ICEIN     DD *
GLOBAL     HDPC=Y,
           ICHLQ=TEMPDS.OSFC0304.IPR,
           UNIT=SYSDA,
           SPACE=(CYL,100,100)
/*

```

Figure 29. Sample JCL stream for Type-A Image Copy for HALDB partitions

Partitions PART2 and PART3 are selected by the PARTITION control statement, and those partitions are reorganized. The IC=YES control statement specifies that image copies of partition data sets be taken within the Smart Reorg utility job step. Because the ICTYPE parameter is not coded, ICTYPE=A is assumed. Note that, for HALDB, the PHIDAM primary index and ILDS are rebuilt but their image copies are not taken. Because DBRCAUTHCMD=YES is coded, you do not need to issue the CHANGE.DB NOAUTH command of DBRC before you start the Smart Reorg utility job or job step. Because NAMESWAP=YES is coded, the automated data set name swapping and DBRC notification processing is done. Because DELOLDDS=YES is specified, if both the data set name swapping and the DBRC notification succeed, the original database data sets, the original primary index data set, and the original ILDS are deleted.

Even if a (partitioned) secondary index (PSINDEX) is defined for the database, the PSINDEX does not need to be reorganized or rebuilt. If you want to rebuild a PSINDEX, you must run an IMS Index Builder job on the entire database after the partitions are reorganized.

## Example 10: Reorganizing and starting a database and indexes

In this example, the database to be reorganized is a HIDAM database that has secondary indexes but no internal logical relationships.

```
//REORG EXEC PGM=HPSGMAIN,PARM='DBD=dbname,DBRC=Y'
//STEPLIB DD DISP=SHR,DSN=IMSTOOLS.SHPSLMD0
//          DD DISP=SHR,DSN=IMSTOOLS.SFOILOAD
//          DD DISP=SHR,DSN=IMSTOOLS.SIIULMOD
//          DD DISP=SHR,DSN=IMS.SDFSRESL
//IMS      DD DISP=SHR,DSN=IMS.DBDLIB
//IMSDALIB DD DISP=SHR,DSN=IMS.MDALIB
//HPSIN    DD *
(REORG)
  DBSHARE=YES
  IMSCMD=YES,TOSI
  TOSIXCFGRP=TGRP1
  TOSITEST=(100,3)
  SPACEALLOC=YES,FORCE
  INDEXBLD=YES
  IC=YES
  NAMESWAP=YES
  DISPOLDDS=DELETE
  STARTDB=YES
/*
//ICEIN    DD *
  GLOBAL   VIC=Y, <-- UIC records for indexes
           VICDSN=&DDN.UC1, <-- DSN used for UIC records
           ICHLQ=TESTDS, <-- ICDS HLQ
           DSN=&ICHLQ.&DDN.IC1, <-- ICDS name convention
           UNIT=SYSALLDA,
           SPACE=(CYL,10,10)
/*
```

Figure 30. Sample JCL stream to reorganize and to start database and indexes

JCL statements shown in the example specify to do the following automated processing; from issuing the /DBD command to issuing the /START DB command in one-step.

### Before reorganization

- DBSHARE=YES, IMSCMD=YES,TOSI, and TOSIXCFGRP=*gname* specify to issue /DBD commands by using the IMS Tools Online System Interface.
- SPACEALLOC=YES specifies to invoke the IDCAMS to allocate DASD space for shadow data sets. If the HPSGAMSA DD statement is not specified, IDCAMS commands are generated automatically. If VSAM data sets with the REUSE option exist, they are reused.

### During reorganization

In addition to Unload and Reload functions, the following optional functions are run concurrently:

- INDEXBLD=YES specifies to invoke the Index Builder function to build secondary indexes. The (INDEXBLD) block can be specified.
- IC=YES and the ICEIN data set specifies to take image copies of the database. Type-A Image Copy is run concurrently with the Reload task.
  - VIC=Y in the ICEIN data set specifies not to take image copies of primary index and secondary indexes, and that UIC records (not IC records) are created in the RECON.
  - If you have IMS HP Pointer Checker, HASH pointer checking is also invoked.

### After reorganization

- DBSHARE=YES, IMSCMD=YES,TOSI, and TOSIXCFGRP=*gname* specify to issue /DBR commands by using IMS Tools Online System Interface.
- NAMESWAP=YES and DISPOLDDS=DELETE specify to do name swapping and delete old data sets.
- STARTDB=YES specifies to issue /START DB commands to start the reorganized database and indexes by using IMS Tools Online System Interface.

For details of each control statement, see [Chapter 9, “Smart Reorg control statements,”](#) on page 117.

## Example 11: Reloading a database and taking an image copy

In this example, the HIDAM database is already unloaded to an unload data set by the IPR Unload utility.

The following figure shows JCL statements that can be used to reload the database from the unload data set and to take image copies concurrently. For more information about this type of reorganization processing, see “REORGINPUT control statement” on page 155.

```
//ALLOC EXEC PGM=IDCAMS
//SYSPRINT DD SYSOUT=*
//SYSIN DD *
DELETE original.database.dataset.name
DELETE original.primary.index.dataset.name
SET MAXCC=0
DEFINE CLUSTER(NAME(original.database.dataset.name) -
               .....) -
DEFINE CLUSTER(NAME(original.primary.index.dataset.name) -
               .....) -
/*
//REORG EXEC PGM=HPSGMAIN,PARM='DBD=SAMPLEDB,DBRC=Y'
//STEPLIB DD DISP=SHR,DSN=IMSTOOLS.SHPSLMD0
// DD DISP=SHR,DSN=IMS.SDFSRESL
// DD DISP=SHR,DSN=DBSAMP01.PGMLIB
//DFSRESLB DD DISP=SHR,DSN=IMS.SDFSRESL
//IMSDALIB DD DISP=SHR,DSN=IMS.MDALIB
//IMS DD DISP=SHR,DSN=IMS.DBDLIB
//DFSUINPT DD DISP=SHR,DSN=DBSAMP01.UNLDLFILE
//HPSIN DD *
(REORG)
  DBRCAUTHCMD=YES
  REORGINPUT=ULDS
  IC=YES
(RELOAD)
  USERHDRX=HPSRCVA3 /* *A3 UNLOAD FORMAT */
  INPUT=,UEXIT01 /* UEXIT01 USER EXIT */
/*
//ICEIN DD *
GLOBAL ICHLQ=IMSICA,
       DSN=&ICHLQ..&DDN..IC1,
       UNIT=SYSALLDA,
       SPACE=(CYL,10,10)
/*
```

Figure 31. Sample JCL stream to reload a database and to take an image copy

Each control statement coded in the HPSIN data set can be either:

- A (REORG) block
  - DBRCAUTHCMD=YES specifies to turn on the DBRC PROHIBIT AUTHORIZATION flag automatically because Smart Reorg requires the flag to start reorganization processing.
  - REORGINPUT=ULDS specifies to deactivate the Unload function and to use the unload data set specified by the DFSUINPT DD statement.
  - IC=YES specifies to take image copies concurrently. You can specify control statements for the Image Copy task in the ICEIN data set so that DASD space is allocated for image copy data sets automatically. If you have IMS HP Pointer Checker, HASH pointer checking is also invoked.
- A (RELOAD) block
  - USERHDRX=HPSRCVA3 specifies to use the \*A3 format for the unload data set.
  - INPUT=,UEXIT01 specifies the user exit module name to be UEXIT01.

If you do not want all libraries that are concatenated to STEPLIB DD to be APF-authorized, you must add the DFSRESLB DD statement.

## Example 12: Performing manual post-processing after a Smart Reorg utility job

In this example, the database to be reorganized is a HIDAM database that has two secondary indexes but has no logical relationship.

This example shows two JCL streams.

The first JCL stream reorganizes a database with NAMESWAP=NO. In this case, manual post-processing must be done after the reorganization. This JCL specifies HPSGSWAP and HPSGDBRC DD statements, so the IDCAMS Command Stream for Name Swapping report and the DBRC Notification Command Stream report are generated in HPSGSWAP and HPSGDBRC data sets.

The second JCL stream performs name swapping and DBRC notification processing by using the command streams that were generated in HPSGSWAP and HPSGDBRC data sets by the first JCL stream.

The following figure shows the first JCL stream.

```
//REORG EXEC PGM=HPSGMAIN, PARM='DBD=SAMPLEDB, DBRC=Y'
//STEPLIB DD DISP=SHR, DSN=IMSTOOLS.SHPSLMD0
// DD DISP=SHR, DSN=IMS.SDFSRESL
// DD DISP=SHR, DSN=USER.PGMLIB
//DFSRESLB DD DISP=SHR, DSN=IMS.SDFSRESL
//IMSDALIB DD DISP=SHR, DSN=IMS.MDALIB
//IMS DD DISP=SHR, DSN=IMS.DBDLIB
//HPSIN DD *
(REORG)
  DBRCAUTHCMD=YES
  INDEXBLD=YES
  NAMESWAP=NO
  DELOLDDS=YES
  STATRL=YES
/*
//HPSGSWAP DD DSN=SAMPLEDB.HPSGSWAP,
// DISP=(NEW,CATLG), SPACE=(TRK,(1,1)), UNIT=SYSDA,
// DCB=(RECFM=FB, LRECL=80, BLKSIZE=4000)
//HPSGDBRC DD DSN=SAMPLEDB.HPSGDBRC,
// DISP=(NEW,CATLG), SPACE=(TRK,(1,1)), UNIT=SYSDA,
// DCB=(RECFM=FB, LRECL=80, BLKSIZE=4000)
//*
```

Figure 32. Sample JCL stream to reorganize a database without name swapping

The following figure shows the second JCL stream.

```
/* ----- *
/* Manual Name Swapping ----- *
/* ----- *
//IDCAMS EXEC PGM=IDCAMS
//SYSPRINT DD SYSOUT=*
//SYSIN DD DISP=SHR, DSN=SAMPLEDB.HPSGSWAP
/*
/* ----- *
/* Manual DBRC Notification Processing ----- *
/* ----- *
//DSPURX00 EXEC PGM=DSPURX00
//STEPLIB DD DISP=SHR, DSN=IMS.SDFSRESL
//SYSPRINT DD SYSOUT=*
//IMS DD DISP=SHR, DSN=IMS.DBDLIB
//RECON1 DD DISP=SHR, DSN=IMS.RECON1
//RECON2 DD DISP=SHR, DSN=IMS.RECON2
//RECON3 DD DISP=SHR, DSN=IMS.RECON3
//SYSIN DD DISP=SHR, DSN=SAMPLEDB.HPSGDBRC
/*
```

Figure 33. Sample JCL stream to perform manual post-processing after reorganization

## Example 13: Reorganizing a HALDB database and rebuilding PSINDEXes

The database to be reorganized is a PHDAM database that has two partitioned secondary indexes (PSINDEXes). This JCL example is for reorganizing all the partitions of the PHDAM database and building each PSINDEX.

```
//REORG EXEC PGM=HPSGMAIN,PARM='DBD=SAMPLEDB,DBRC=Y'  
//STEPLIB DD DISP=SHR,DSN=IMSTOOLS.SHPSLMD0  
// DD DISP=SHR,DSN=IMSTOOLS.SFOILOAD  
// DD DISP=SHR,DSN=IMSTOOLS.SIIULMOD  
// DD DISP=SHR,DSN=IMS.SDFSRESL  
// DD DISP=SHR,DSN=DBSAMP01.PGMLIB  
//DFSRESLB DD DISP=SHR,DSN=IMS.SDFSRESL  
//IMSDALIB DD DISP=SHR,DSN=IMS.MDALIB  
//IMS DD DISP=SHR,DSN=IMS.DBDLIB  
//HPSIN DD *  
(REORG)  
IMSCMD=YES,TOSI  
TOSIXCFGRP=TGRP1  
TOSITEST=(100,3)  
SPACEALLOC=YES,FORCE  
PSINDEXBLD=YES,NEW  
IC=YES  
NAMESWAP=YES  
STARTDB=YES  
DISPOLDDS=DELETE  
/*  
//ICEIN DD *  
GLOBAL ICHLQ=IMSICA,  
DSN=&ICHLQ..&DDN..IC1,  
UNIT=SYSALLDA,  
SPACE=(CYL,10,10)  
/*
```

Figure 34. Sample JCL stream to reorganize a HALDB that has two partitioned secondary indexes

The following control statements are coded in the HPSIN data set:

- IMSCMD=YES,TOSI specifies to issue /DBR DB commands for all PHDAM partitions and PSINDEX partitions by using the IMS Tools Online System Interface.
- SPACEALLOC=YES,FORCE specifies to dynamically allocate the space for shadow data sets of all PHDAM partitions and PSINDEX partitions.
- Because the ILDSBLD control statement is not specified, default value ILDSBLD=YES,COND is applied to the job. If the HALDB has logical relationships, the Smart Reorg utility rebuilds ILE records. If the HALDB has no logical relationships, the Smart Reorg utility initializes the ILDS but does not build ILE records.
- PSINDEXBLD=YES,NEW specifies to activate the Index Builder task to rebuild each PSINDEX. Index records are loaded into shadow data sets.  
**Tip:** If you specify PSINDEXBLD=YES,CURRENT, index records are directly loaded into original data sets. Therefore, no additional space is required for shadow data sets for PSINDEX partitions.
- IC=YES specifies to create image copies of the data sets of all PHDAM partitions and PSINDEX partitions with Type-B Image Copy processing. You can specify control statements for the Image Copy task in the ICEIN data set to automatically allocate DASD space for image copy data sets.
- NAMESWAP=YES specifies to do name swapping between the original data set and the shadow data for all PHDAM partitions and PSINDEX partitions.
- STARTDB=YES specifies to issue /START DB commands for all PHDAM partitions and PSINDEX partitions by using the IMS Tools Online System Interface when the reorganization ends.
- DISPOLDDS=DELETE specifies to delete all old data sets of all PHDAM partitions and PSINDEX partitions.

## Example 14: Conditional reorganization based on the number of days since the last reorganization

If you store utility history data in the IMS Tools KB repository, the Smart Reorg utility evaluates the number of days since the last reorganization and reorganizes the database when the number of days exceeds the threshold defined by the rule.

To perform this type of conditional reorganization, complete the following steps. Steps “1” on page 199 and “2” on page 199 are one-time tasks.

**Prerequisite:** Your environment must be configured for the Conditional Reorganization Support Service. See Chapter 3, “Configuring the IMS Database Reorganization Expert environment,” on page 43.

1. Use the Policy Services ISPF interface to create or customize a reorganization policy.

The reorganization policy must include the rule IBM.LAST\_REORG.10, which evaluates the number of days since the last reorganization.

For more information about creating and customizing reorganization policies, see the topic “Using Policy Services” in the *IMS Tools Base Policy Services User's Guide and Reference*.

**Note:** If you do not see the IBM.LAST\_REORG.10 rule in the list of rules, install the latest policy package and apply the latest maintenance to Policy Services.

2. Run a reorganization job in Unconditional reorganization mode at least once to store utility history data in the IMS Tools KB Sensor Data repository.

Utility history data contains the reorganization timestamp, which is later used to evaluate the number of days since the last reorganization.

As shown in the following JCL example, you must specify the following control statements in the (REORG) block of the job:

- ITKBSRVR statement, to specify the IMS Tools KB server XCF group
- ITKBDATA=UTILHIST statement, to store the utility history data in the IMS Tools KB server repository

```
//UCREORG EXEC PGM=HPSGMAIN,PARM='DBD=SAMPLEDB,DBRC=Y'  
//STEPLIB DD DISP=SHR,DSN=IMSTOOLS.SHPSLMD0  
// DD DISP=SHR,DSN=IMSTOOLS.SHKTL0AD /* ITKB, Policy Services */  
// DD DISP=SHR,DSN=IMS.SDFSRESL  
// DD DISP=SHR,DSN=USER.PGMLIB  
//IMSDALIB DD DISP=SHR,DSN=IMS.MDALIB  
//IMS DD DISP=SHR,DSN=IMS.DBDLIB  
//HPSIN DD *  
(REORG)  
ITKBSRVR=FPQSVR00  
ITKBDATA=UTILHIST  
CONDREORG=NO  
SPACEALLOC=YES  
NAMESWAP=YES  
/*
```

3. Run the conditional reorganization job in Conditional Reorganization mode.

When the job is submitted, the Smart Reorg utility refers to the utility history data in the IMS Tools KB repository, evaluates the number of days since the last reorganization, and determines if the database requires a reorganization. If the utility determines that a database reorganization is necessary, the utility reorganizes the database and adds new utility history data in the IMS Tools KB repository.

As shown in the following JCL example, specify the following control statements:

### (REORG) block

- ITKBSRVR statement, to specify the IMS Tools KB server XCF group.
- ITKBDATA=UTILHIST statement, to store the utility history data in the IMS Tools KB server repository. The utility history data is stored only when the database is reorganized.
- CONDREORG=YES statement, to run the job in Conditional Reorganization mode.

Ensure that the job specifies the policy that you prepared in step “1” on page 199. You can optionally use the following control statements to specify a policy:

**(CONDREORG) block**

- POLICYBY statement
- POLICYNM statement

In the following JCL example, the reorganization policy that was customized in step “1” on page 199 is specified by the POLICYBY keyword. The reorganization policy uses the IBM.LAST\_REORG.10 rule to evaluate the number of days since the last reorganization.

```
//CREORG EXEC PGM=HPSGMAIN,PARM='DBD=SAMPLEDB,DBRC=Y'
//STEPLIB DD DISP=SHR,DSN=IMSTOOLS.SHPSLMD0
// DD DISP=SHR,DSN=IMSTOOLS.SHKTLOAD /* ITKB, Policy Services */
// DD DISP=SHR,DSN=IMS.SDFSRESL
// DD DISP=SHR,DSN=USER.PGMLIB
//IMSDALIB DD DISP=SHR,DSN=IMS.MDALIB
//IMS DD DISP=SHR,DSN=IMS.DBDLIB
//HPSIN DD *
(REORG)
ITKBSRVR=FPQSVR00
ITKBDATA=UTILHIST
CONDREORG=YES
SPACEALLOC=YES
NAMESWAP=YES
(CONDREORG)
POLICYBY=DBTYPE
/*
```

The Diagnosis report contains data element DB\_DAYS\_SINCE\_LAST\_REORG because the rule IBM.LAST\_REORG.10 was used.

```
Database Statistics (DBD: dbname)
-----
=====
Events Statistics
=====

Note: The mark * in column P means that the data element is used in the policy.

Data Element Name      P      Before Reorg      After Reorg      Difference
-----
DB_DAYS_SINCE_LAST_REORG *          30          0          -30
```



## Example 15: Reorganizing a database when the IMS management of ACBs is enabled

This JCL example is for reorganizing a database in an IMS-managed ACBs environment.

```
//REORG EXEC PGM=HPSGMAIN, PARM=' DBD=SAMPLEDB, DBRC=Y, DFSDF=CAT '  
//STEPLIB DD DISP=SHR, DSN=IMSTOOLS.SHPSLMD0  
// DD DISP=SHR, DSN=IMSTOOLS.SIIULMOD  
// DD DISP=SHR, DSN=IMSTOOLS.SFOILOAD  
// DD DISP=SHR, DSN=IMSTOOLS.SGLXLOAD  
// DD DISP=SHR, DSN=IMS.SDFSRESL  
// DD DISP=SHR, DSN=DBSAMP01.PGMLIB  
// DD DISP=SHR, DSN=IMS.MDALIB  
//DFSRESLB DD DISP=SHR, DSN=IMS.SDFSRESL  
//PROCLIB DD DISP=SHR, DSN=IMS.PROCLIB  
//HPSIN DD *  
(REORG)  
IMSCMD=YES, TOSI  
SPACEALLOC=YES  
ILDSBLD=YES, INITONLY  
PSINDEXBLD=YES, NEW  
IC=YES  
NAMESWAP=YES  
STARTDB=YES  
DISPOLDDS=DELETE  
/*  
//ICEIN DD *  
GLOBAL ICHLQ=IMSICA,  
DSN=&ICHLQ..&DDN..IC1,  
UNIT=SYSALLDA,  
SPACE=(CYL,10,10)  
/*
```

Figure 35. Example JCL stream to reorganize a database in an IMS-managed ACBs environment

- The DFSDF=CAT parameter on the EXEC statement and the PROCLIB DD statement specify the DFSDFCAT PROCLIB member that contains the IMS catalog definition.

If you include the IMS Catalog Definition exit routine (DFS3CDX0) in the STEPLIB concatenation, you do not need to specify the DFSDF parameter and the PROCLIB DD statement.

- The SGLXLOAD library of IMS Tools Base must be in the STEPLIB concatenation.
- The library containing the DFSMDA member with TYPE=CATDSDLQ statement must be in the STEPLIB concatenation. Other types of DFSMDA members can be in the IMSDALIB DD concatenation.
- The IMS DD statement is not needed.

If you want to reload the database using the pending database definition in IMS catalog staging data sets, add the NEWDBD control statement as follows:

```
//HPSIN DD *  
(REORG)  
NEWDBD=*STAGING  
...  
/*
```

If the input for reorganization processing is an unload data set, code the REORGINPUT=ULDS control statement in the (REORG) block of the HPSIN data set and add the DFSACBPD DD statement that contains the STAGING keyword as shown in the following example. In this case, the NEWDBD control statement cannot be specified.

```
//HPSIN DD *  
(REORG)  
REORGINPUT=ULDS  
...  
/*  
//DFSACBPD DD *  
STAGING  
/*
```

## Example 16: Conditionally reorganizing a database in separate job steps

This example shows JCL streams to evaluate a HIDAM database and, if the database requires a reorganization, create an unload data set and run the reorganization in the succeeding job step.

In this example:

- The database is evaluated by the Conditional Reorganization Support Service (CRSS). If the database needs to be reorganized, the Smart Reorg utility calls the Unload task to create an unload data set and returns a specific return code, which will be passed to the succeeding job step.
- If a specific code is returned in the first job step, the data sets of the database and its secondary indexes are deleted and newly defined. The database is reorganized in one job step by the Smart Reorg utility, which calls the Reload task, the Index Build task, and the Image Copy task.

```
//CONDUNLD EXEC PGM=HPSGMAIN, PARM='DBD=SAMPDB01,DBRC=Y'  
//STEPLIB DD DISP=SHR,DSN=IMSTOOLS.SHPSLMD0  
// DD DISP=SHR,DSN=IMSTOOLS.SFOILOAD /* TOSI */  
// DD DISP=SHR,DSN=IMSTOOLS.SHKTLOAD /* ITKB, Policy Services */  
// DD DISP=SHR,DSN=IMS.SDFSRESL  
  
// DD DISP=SHR,DSN=USER.PGMLIB  
//IMS DD DISP=SHR,DSN=IMS.DBDLIB  
//DFSURGU1 DD DSN=SAMPDB01.UNLOAD,DISP=(NEW,PASS),  
// SPACE=(CYL,(20,10))  
//HPSIN DD *  
(REORG)  
CONDREORG=YES  
ITKBSVR=FPQSVR00  
RC_CHANGE=(POLICY.EXCEPTIONS.CRITICAL,20)  
RC_CHANGE=(POLICY.ACTION.REORG,22)  
UNLOADONLY=YES  
DBRCAUTHCMD=YES  
IMSCMD=YES,TOSI  
TOSIXCFGRP=REORG  
STARTDB=YES  
(CONDREORG)  
POLICYBY=DBTYPE  
(UNLOAD)  
CHECKREC=YES  
/
```

Figure 36. Sample JCL stream to diagnose a database and conditionally unload the database

- CONDREORG=YES and UNLOADONLY=YES specify to diagnose the database and unload the database if the database needs to be reorganized.

If CONDREORG=YES,REORGDIAG is specified instead of CONDREORG=YES, the database is always unloaded regardless of the evaluation result.

- The DFSURGU1 DD statement specifies the output unload data set.
- RC\_CHANGE=(POLICY.ACTION.REORG,22) specifies that return code 22 is returned if the database requires reorganization.
- The database must be in read-only state while it is being unloaded. DBRCAUTHCMD=YES specifies to issue DBRC commands, and IMSCMD=YES,TOSI specifies to issue IMS commands automatically.
- CHECKREC=YES in the (UNLOAD) block is required to pass certain information to the Reload task called in the succeeding job step.

```

//IFTEST  IF (CONDUNLD.RC = 22) THEN /* REORG IS NEEDED? */
//DELDEF  EXEC PGM=IDCAMS
//SYSPRINT DD SYSOUT=*
//SYSIN   DD DISP=SHR,DSN=USER.DDEFPDS(SAMPDB01)
//        DD DISP=SHR,DSN=USER.DDEFPDS(SAMPIDX0)
//        DD DISP=SHR,DSN=USER.DDEFPDS(SAMPIDX1)
//        DD DISP=SHR,DSN=USER.DDEFPDS(SAMPIDX2)
//*
//REORG   EXEC PGM=HPSGMAIN,PARM='DBD=SAMPDB01,DBRC=Y'
//STEPLIB DD DISP=SHR,DSN=IMSTOOLS.SHPSLMD0
//        DD DISP=SHR,DSN=IMSTOOLS.SIIULMOD
//        DD DISP=SHR,DSN=IMSTOOLS.SFOILOAD /* TOSI */
//        DD DISP=SHR,DSN=IMSTOOLS.SHKTLOAD /* ITKB, Policy Services */
//        DD DISP=SHR,DSN=IMS.SDFSRESL
//        DD DISP=SHR,DSN=USER.PGMLIB
//IMS     DD DISP=SHR,DSN=IMS.DBDLIB
//DFSUINPT DD DISP=SHR,DSN=SAMPDB01.UNLOAD
//HPSIN DD *
(REORG)
ITKBSVR=FPQSVR00
REORGINPUT=ULDS
DBRCAUTHCMD=YES
IMSCMD=YES,TOSI
TOSIXCFGRP=REORG
INDEXBLD=YES
IC=YES
STARTDB=YES
(RELOAD)
:
/*
//ICEIN DD *
GLOBAL VIC=Y,VICDSN=&DDN..UC1,
        ICHLQ=IMSICA,DSN=&ICHLQ..&DDN..IC1,
        UNIT=SYSALLDA,SPACE=(CYL,10,10)
/*
//ENDTEST ENDIF

```

Figure 37. Sample JCL stream to reorganize the database depending on the return code from the previous step

- These two job steps are processed when the return code from the CONDUNLD job step indicates that the database requires a reorganization.
- Before starting the Smart Reorg step, the original database data sets are deleted and defined. Shadow data sets are not used.
- REORGINPUT=ULDS specifies to reload the database using the unload data set that the DFSUINPT DD statement specifies.
- INDEXBUILD=YES and IC=YES specify to call the Index Builder task and the Image Copy task.
- IMSCMD=YES,TOSI specifies to issue IMS /DBR commands, and STARTDB=YES specifies to issue IMS /STA commands automatically.



---

# Chapter 11. Working with policies and database exceptions

When you run a Smart Reorg utility job in Conditional Reorganization mode, Reorganization Diagnosis mode, or Diagnosis-only mode, you must prepare a reorganization policy before running the job and check the job result after the job is complete.

## Topics:

- [“Preparing a reorganization policy” on page 205](#)
- [“Checking the policy evaluation summary message” on page 205](#)
- [“Identifying the cause of database exceptions” on page 206](#)
- [“Resolving database exceptions” on page 207](#)
- [“Finding Diagnosis reports by using report completion codes” on page 208](#)

---

## Preparing a reorganization policy

Before you run a Smart Reorg utility job in Conditional Reorg mode, Reorganization Diagnosis mode, or Diagnosis-only mode, you must prepare a reorganization policy.

### About this task

You can prepare a reorganization policy by customizing a policy template provided from IBM. The customization of a policy template includes setting specific criteria for detecting database exceptions and for determining when a database needs to be reorganized. You can also specify whether to receive exception notification messages of the Smart Reorg utility through z/OS WTO service or TSO/E SEND command.

### Procedure

See the topic "Using Policy Services" in the *IMS Tools Base Policy Services User's Guide and Reference* for information about customizing IBM-provided policies and rules, and how to create your own policies. This information also provides a complete reference for IBM-provided policies and rules.

---

## Checking the policy evaluation summary message

If one or more database exceptions were detected during a Smart Reorg utility job and if one or more notification lists are specified in the policy that is used, a message that summarizes policy evaluation is sent to the designated targets by Policy Services. This message is called the *policy evaluation summary message* or *summary message*.

### Procedure

The policy evaluation summary message is always displayed at the end of the Summary of Policy Evaluation section of the Diagnosis report. From this message, you can check the result of policy evaluation and the action that was taken during the job.

A report completion code is assigned to the Diagnosis report when the report is stored in the Output repository of IMS Tools KB. The code is associated with the summary message. For the relation between report completion codes and policy evaluation summary messages, see [Table 30 on page 209](#).

The following list summarizes policy evaluation summary messages. For information about each summary message (the action that is taken by the Smart Reorg utility and the action that you must take), see [“BBE messages” on page 666](#).

- BBE2900I *resource\_name* IN RECONID=*recon\_id* HAS BEEN REORGANIZED, AND NO EXCEPTIONS WERE DETECTED AFTER THE REORG.
- BBE2901I *resource\_name* IN RECONID=*recon\_id* HAS BEEN REORGANIZED, BUT SOME WARNING EXCEPTIONS REMAIN.
- BBE2902I *resource\_name* IN RECONID=*recon\_id* HAS WARNING EXCEPTIONS IN THE REORG DOMAIN.
- BBE2903I *resource\_name* IN RECONID=*recon\_id* HAS BEEN REORGANIZED, BUT IS STILL IN A "REORG NEEDED" STATE.
- BBE2904I *resource\_name* IN RECONID=*recon\_id* HAS BEEN REORGANIZED, BUT IS STILL IN A CRITICAL STATE.
- BBE2905I *resource\_name* IN RECONID=*recon\_id* HAS CRITICAL EXCEPTIONS IN THE REORG DOMAIN. USER ACTION IS REQUIRED.
- BBE2906I THE REORGANIZATION OF *resource\_name* IN RECONID=*recon\_id* WAS ATTEMPTED AND FAILED.
- BBE2907I *resource\_name* IN RECONID=*recon\_id* HAS BEEN REORGANIZED, BUT IS STILL IN A SEVERE STATE.
- BBE2908I *resource\_name* IN RECONID=*recon\_id* HAS SEVERE EXCEPTIONS IN THE REORG DOMAIN.
- BBE2909I *resource\_name* IN RECONID=*recon\_id* HAS BEEN REORGANIZED, BUT ITS STATUS IS UNAVAILABLE.
- BBE2910I ACTION "REORG" IS RECOMMENDED FOR *resource\_name* IN RECONID=*recon\_id*.

#### **Related reference**

BBERPRT data set: Diagnosis report

The BBERPRT data set contains Diagnosis reports that are generated by conditional reorganization jobs.

Control statements for the Smart Reorg Driver

The control statement block for the Smart Reorg Driver contains user specifications for controlling the processes of the Smart Reorg Driver and the Parallel Reorganization Service.

## **Identifying the cause of database exceptions**

---

The Summary of Policy Evaluation section of the Diagnosis report prints the remaining database exceptions.

If one or more of the following exceptions remain after a Smart Reorg utility job that ran in Conditional Reorganization mode or in Reorganization Diagnosis mode, or if they were reported by a Smart Reorg utility job that ran in Diagnosis-only mode, you should tune the database definition, the data set allocation, or both.

- Exceptions that might be related to number of database I/Os include:
  - AVERAGE\_DB\_RECORD\_LENGTH
  - EXCESSIVE\_SEGMENT\_SCATTERING
  - EXCESSIVE\_HDAM\_ROOTS\_NOT\_HOME (for HDAM/PHDAM)
  - EXCESSIVE\_HDAM\_ROOTS\_OVERFLOW (for HDAM/PHDAM)
  - IMBALANCED\_RANDOMIZING (for HDAM/PHDAM)
- Exceptions that might be related to the space usage of the database include:
  - DATA\_SET\_EXTENTS\_AVAILABILITY
  - GROWING\_DBDS\_WITH\_DATA\_FULL
  - EXCESSIVE\_HDAM\_ROOTS\_NOT\_HOME (for HDAM/PHDAM)
  - EXCESSIVE\_HDAM\_ROOTS\_OVERFLOW (for HDAM/PHDAM)

**Note:** If you run the job in Diagnosis-only mode and if the Diagnosis report contains only the following exceptions, they can be removed by a simple reorganization without changing the database structure or space allocation:

- EXCESSIVE\_SLACK\_BYTES
- EXCESSIVE\_VL\_SPLIT\_SEGMENTS
- FRAGMENTED\_FREE\_SPACES
- GROWING\_DBDS\_WITH\_FREE\_SPACES
- EXCESSIVE\_CI\_OR\_CA\_SPLITS (for HISAM and SHISAM)
- EXCESSIVE\_HISAM\_DELETE\_SEGM (for HISAM)

For detailed explanations about database exceptions that can be detected by IBM-provided rules, see the topic "Domain REORG exceptions" in the *IMS Tools Base Policy Services User's Guide and Reference*.

### Related tasks

[Resolving database exceptions](#)

The Smart Reorg utility and other utilities of IMS Database Reorganization Expert provide various reports that help you resolve database exceptions.

### Related reference

BBERPRT data set: [Diagnosis report](#)

The BBERPRT data set contains Diagnosis reports that are generated by conditional reorganization jobs.

## Resolving database exceptions

---

The Smart Reorg utility and other utilities of IMS Database Reorganization Expert provide various reports that help you resolve database exceptions.

### Before you begin

This topic describes how you can resolve database exceptions that were reported by Policy Services.

Before going through the steps in this topic, you need to identify the names of the exceptions that were reported.

### Procedure

To resolve database exceptions, complete these steps:

1. Generate additional reports that contain detailed database statistics by running an IPR Unload job with the STATREP=YES and the DBSTATS=YES options.

For a list of reports that can help you tune databases, see [“Reports for database tuning” on page 629](#).

**Note:** You do not need to create an unload data set when you run the IPR Unload job. To suppress the creation of an unload data set, you can code the data set format \*NO for the OUTPUT control statement for the IPR Unload job (OUTPUT=, \*NO). For more information about the OUTPUT control statement, see [“OUTPUT control statement” on page 375](#).

2. When the IPR Unload reports are generated, see the appropriate guideline that matches the type of the database you are processing or the database condition.

Guidelines are located in the following topics:

- [“Working on exceptions in an HDAM database” on page 631](#)
- [“Working on exceptions in a HIDAM database” on page 644](#)
- [“Working on exceptions in a HISAM or SHISAM database” on page 646](#)
- [“Working on space shortage exceptions” on page 649](#)

Follow the guidelines to change the DBD, the data set allocation parameters, or both.

3. Reload the database by using the IPR Reload utility. Optionally, you can specify a new DBD.

4. Determine if the reloaded database is satisfactory by checking the reports that were produced by the IPR Reload job.

For details, see [“Reports for database tuning” on page 629](#).

5. If the result in step [“4” on page 208](#) is not satisfactory, repeat steps [“2” on page 207](#) through [“5” on page 208](#).

**Tip:** If the database is very large, performing multiple consecutive reloads or unloads in order to observe the effect of multiple consecutive changes is not practical. In this case, you can use the FABHURG1 unload utility and the FABHEXTR exit routine to create a small database extract that consists of a subset of the real-life database records. For more information, see the topic "Creating a database extract for tuning experiments" in the *IMS High Performance Unload User's Guide*. You can then perform tuning experiments with this smaller database extract.

For more information about the FABHEXTR exit routine of the FABHURG1 unload utility, see the *IMS High Performance Unload User's Guide*.

### Related concepts

[Identifying the cause of database exceptions](#)

The Summary of Policy Evaluation section of the Diagnosis report prints the remaining database exceptions.

### Related reference

[Reports for database tuning](#)

The utilities of IMS Database Reorganization Expert generate various useful reports that assist you when tuning your IMS databases.

## Finding Diagnosis reports by using report completion codes

---

You can use report completion codes (RCC) to find only those Diagnosis reports that suggest further user actions. The report completion code is notified by WTO message BBE0315I or BBE0316A.

### About this task

Report completion code is available when you run a Smart Reorg job in Conditional Reorganization mode, in Reorganization Diagnosis mode, or in Diagnosis-only mode and you specify to store Diagnosis report in the Output repository of IMS Tools KB server.

To use report completion codes to find specific Diagnosis reports from the Output repository of the IMS Tools KB server, follow these steps:

### Procedure

1. In the IMS Tools KB main menu panel, specify the following information:
  - Specify the server name in the **Knowledge Base Server Name** field.
  - Specify N in the **History** field.
  - Specify the **Recon ID** that corresponds to Recon data sets that are used for the database in the Recon ID field.
2. Select option 7, **List of Products**, from the main menu panel. Press Enter.

The List of Products panel is displayed.
3. Use the **View** row action (S) on the entry of IBM IMS Database Reorganization Expert for z/OS. Press Enter.

The Available Reports-Product panel is displayed.
4. Enter the **Filter** command.

The Set Filter panel is displayed.
5. Enter the report completion code in **Cmp Cod**. Press Enter.



When you enter the report completion code, the Available Report-Product panel is displayed, and only those reports that have the specified report completion code are listed on the panel.

The following table summarizes the possible report completion codes and their exception levels.

*Table 30. Report completion codes for Diagnosis report*

<b>Report completion code</b>	<b>Highest exception level</b>	<b>Accompanying policy evaluation summary message</b>
0	No exception is observed	No message BBE2900I
4	Warning	BBE2901I BBE2902I
8	Severe	BBE2907I BBE2908I
12	Critical	BBE2906I
16	Critical	BBE2903I BBE2904I BBE2905I BBE2910I
20	Unknown	BBE2909I
24	Unknown	BBE2909I

**Related reference**

BBERPRT data set: Diagnosis report

The BBERPRT data set contains Diagnosis reports that are generated by conditional reorganization jobs.



---

## Chapter 12. Preparing and completing reorganization

When you run a Smart Reorg utility job in Conditional Reorganization mode, in Reorganization Diagnosis mode, or in Unconditional Reorganization mode, you must configure pre-reorganization processing and post-reorganization processing.

### Topics:

- [“Pre-reorganization processing” on page 211](#)
- [“Post-reorganization processing” on page 212](#)

---

### Pre-reorganization processing

You must perform pre-reorganization processing before you run a Smart Reorg utility job except when you run the job in Diagnosis-only mode.

#### Procedure

Pre-reorganization processing for the Smart Reorg utility includes taking the database offline or putting it in *read-only* mode to prevent database access while the reorganization process is running.

To have the Reorganization Manager of the Parallel Reorganization Service perform this processing automatically, specify `IMSCMD=YES` or `DBRCAUTHCMD=YES`.

If you do not specify `IMSCMD=YES` or `DBRCAUTHCMD=YES`, the database to be reorganized must be taken offline or put in read-only mode in a separate step before the Smart Reorg utility job step starts. Use either of the following methods to complete this task:

- If you specify `DBSHARE=NO` in the (REORG) block, issue the following command to prevent any authorization for the database during the reorganization:  
`/DBRECOVERY DATABASE dbname GLOBAL NOFE0V`
- If you specify `DBSHARE=YES` in the (REORG) block, issue the following command to allow read-only access for the database during the reorganization:  
`/DBDUMP DATABASE dbname GLOBAL NOFE0V`

If the database is shared by multiple IMS subsystems, make sure that the commands are processed successfully in all IMS subsystems.

If you specify `AUTHFAIL=WTOR` and you have not issued the `/DBDUMP` or the `/DBRECOVERY` command, the Smart Reorg utility issues a message to tell the operator which command must be issued to which database.

For more information about automating pre-reorganization processing, see [“Hints and tips for specifying control statements” on page 178](#).

#### Related reference

##### [AUTHFAIL control statement](#)

Specifies the action Reorganization Manager takes when DBRC authorization fails during initialization processing and before name swapping.

##### [DBRCAUTHCMD control statement](#)

Specifies whether Reorganization Manager issues the `CHANGE.DB READON` or the `CHANGE.DB NOAUTH` command automatically at the beginning of the reorganization and before data set name swapping.

##### [DBSHARE control statement](#)

Specifies whether read access for the database is allowed while the database is being reorganized.

##### [IMSCMD control statement](#)

Specifies whether Reorganization Manager issues the /DBD or /DBR command automatically at the beginning of the reorganization and before data set name swapping.

## Post-reorganization processing

---

You must perform post-reorganization processing after a Smart Reorg utility job when a reorganization has been committed.

### About this task

Most part of post-reorganization processing can be done automatically by the Reorganization Manager of the Parallel Reorganization Service if such specifications are made with control statements.

During automatic post-reorganization processing, messages are issued to report the beginning and the completion of each task. These messages are displayed on the operator console but they are not written to any data sets. For more information about automating post-reorganization processing, see [“Hints and tips for specifying control statements” on page 178](#).

## Performing manual name swapping

The name swapping process swaps the name of the shadow database with the name of the original database.

### Procedure

Complete the following steps to do data set name swapping manually:

1. Issue a /DBRECOVERY command for each database involved to obtain exclusive control of the database. You must specify the GLOBAL option if the database is shared by multiple IMS systems. You must ensure that the /DBRECOVERY command that is issued on the local IMS system and the /DBRECOVEY commands that are propagated to the sharing IMS systems all complete successfully.

When data set names are swapped for a HALDB, you must issue the /DBRECOVERY command for each partition that has been reorganized.

2. Create IDCAMS ALTER statements to swap database data set names.

Refer to the sample ALTER commands that are written in the HPSOUT2 data set. If you have specified the HPSGSWAP DD statement, the HPSGDBRC DD statement, or both, the same command stream is written in the data set that is specified on the DD statement. The data set that is specified on the HPSGSWAP DD statement is intended to be used as the SYSIN for IDCAMS, and the data set that is specified on the HPSGDBRC DD statement is intended to be used as the SYSIN for DSPURX00. You can use the command stream without change, or you can modify it to suit to your requirements. For sample command streams, see [“IDCAMS Command Stream for Name Swapping report” on page 264](#) and [“DBRC Notification Command Stream report” on page 268](#).

For VSAM data sets, you must rename the cluster and component names together.

**Attention:** Be careful when you specify control statement INDEXBLD=YES,NEW for a database for which a secondary index is defined but the original index data set does not exist. In this case, the IDCAMS command stream that is generated by the Smart Reorg utility can be used only for renaming the cluster name of the shadow index data set to the cluster name of the original index data set. The commands for renaming the index and data components are not generated, and the information message HPSG0311I is issued. If you also want to change the component names, add the lines (\*1), as shown in the following figure.

```

IF MAXCC EQ 0 THEN -
DO
  ALTER    cluster_of_shadow_index_data_set    -
  NEWNAME(cluster_of_original_index_data_set  )
*1 ALTER    data_component_of_shadow_index_data_set -
*1 NEWNAME(data_component_of_original_index_data_set )
*1 ALTER    index_component_of_shadow_index_data_set -
*1 NEWNAME(index_component_of_original_index_data_set)
END

```

Figure 38. IDCAMS command stream for changing cluster and component names for secondary index

## Performing manual DBRC notification processing

DBRC notification processing must be done after the data set names have been swapped.

### About this task

This process can also be done automatically. For information about setting up automatic DBRC notification processing, see “How to automate DBRC notification processing” on page 179. To have the Smart Reorg utility process this step automatically, satisfy the requirements described in “[NAMESWAP control statement](#)” on page 147.

### Procedure

The following steps describe how to manually perform DBRC notification processing.

**Note:** These steps describe a typical method for performing manual DBRC notification processing. A different method might be more appropriate for your installation.

1. Notify DBRC that the reorganization has taken place. For a non-HALDB, issue the following commands for all DD names of the reorganized database and primary index. For a HALDB, issue the command for each partition and each DD name of the partition except the DD name for ILDS and the primary index of PHIDAM.

```
NOTIFY.REORG DBD(dbd_or_part_name) DDN(ddname)
```

**Note:** For a non-HALDB, it is assumed that the secondary indexes, if defined, are rebuilt or reorganized, and also that the above NOTIFY.REORG commands have not been issued for the secondary indexes in other index building step. If these commands have been issued in an index building step, you can ignore this step.

For each HALDB partition, issue the following commands:

- If the PARTITION INIT NEEDED flag is on, you must issue the command to turn off the flag because all the partitions that are processed by the Smart Reorg utility have been initialized.

```
CHANGE.DB DBD(part_name) NOPINIT
```

- If the HALDB partition is capable of online reorganization and at least one online reorganization has been done before the parallel reorganization, you must issue the CHANGE .DB DBD(*part\_name*) NOPINIT command for both A-through-J and X data sets and M-through-V and Y data sets. And, if the M-through-V and Y data sets are active when the parallel reorganization starts, you also need to issue the following command for the partition:

```
CHANGE.DB DBD(part_name) OLRDBDS(A)
```

2. Take an image copy of the database and indexes that are registered to DBRC as RECOVABL, and register the image copy data sets to DBRC. You can use the Database Image Copy utility (DFSUDMPO) or the Database Image Copy 2 utility (DFSUDMT0) or IMS HP Image Copy to complete this step.

For a non-HALDB, if you do not need to get an image copy of the database or indexes that are defined as NONRECOV, you can optionally issue the following command for such database or indexes:

```
NOTIFY.UIC DBD(dbd_or_part_name) DDN(ddname)
```

**Note:** For a HALDB, you do not need to issue the command for ILDS and the primary index of PHIDAM because they are always defined as nonrecoverable.

3. Issue the following DBRC command to allow authorization for the database. For a non-HALDB, the command must be issued for the database and for the indexes (the primary index of HIDAM and all secondary indexes if defined). For a HALDB, the command must be issued for each partition that has been reorganized.

```
CHANGE.DB DBD(dbd_or_part_name) AUTH READOFF
```

## Performing manual image copy processing

To manually take the image copies of the reorganized database, you must run IMS HP Image Copy.

### About this task

**Important:** You must take Image copies of the reorganized database before the database is used by any application programs.

## Post-reorganization processing for database with logical relationships

The following considerations apply when performing post-reorganization processing for non-HALDB that has logical relationships.

### Internal logical relationships

If you are reorganizing an HDAM or a HIDAM database that has only internal logical relationships, you can do the post-reorganization processing automatically by specifying PREFIXRES=YES and NAMESWAP=YES.

However, if PREFIXRES=NO and NAMESWAP=YES are specified for such a database, the automated name swapping is done for the database data sets, the primary index data sets, and the secondary index data sets. The NOTIFY.REORG commands are issued for these three types of data sets, but the CHANGE.DB AUTH READOFF commands are issued only for the primary and the secondary index data sets. You must run the IMS Prefix Resolution and Prefix Update utilities, take image copies, and issue the CHANGE.DB AUTH READOFF commands for the database data sets in subsequent job steps.

### External logical relationships

If you are reorganizing an HDAM or a HIDAM database that has external logical relationships or a HISAM database that has internal or external logical relationships, you must run IMS Prefix Resolution and Prefix Update utilities after the Smart Reorg job step.

### About this task

Follow these steps to complete manual post-reorganization processing for databases that are involved in such logical relationships.

**Tip:** Instead of completing these steps, you can use the Pre-reorganization utility and the Post-reorganization utility to automatically process these steps. For more information, see [Chapter 14, “Pre-reorganization utility and Post-reorganization utility,”](#) on page 287.

### Procedure

1. Run an IMS Database Preorganization utility job.
2. Submit reorganization jobs to reorganize or scan each database.

You can use the IMS Database Scan utility or the IPR DB Scan utility to scan logically related databases that are not reorganized. For details about the IPR DB Scan utility, see [Chapter 39, “IPR DB Scan utility,”](#) on page 585.

3. Perform name swapping manually for the databases and indexes that are reorganized or rebuilt by the Smart Reorg utility. After that, issue the DBRC NOTIFY.REORG commands manually to the databases and indexes.

For details, see [“Performing manual name swapping”](#) on page 212.

If NAMESWAP=YES is specified in the Smart Reorg job step, this step is not needed.

4. Run the IMS Prefix Resolution and Prefix Update utilities to complete logical relationship prefix processing.
5. Take image copies by using any IMS image copy utility.
6. Issue the DBRC CHANGE.DB AUTH READOFF commands to the database and indexes manually.

For more information about the DBRC commands, see [“Performing manual DBRC notification processing”](#) on page 213.

## Restarting the reorganized database

After you have completed the reorganization and post-reorganization processing, you must issue the /START DB command for the database and indexes so that the database can be accessible from online application programs.

### About this task

For a HALDB, you must start each partition that was reorganized. You must also start the HALDB master database if it was stopped before or during the reorganization.

If STARTDB=YES is specified, Smart Reorg utility issues the /START DB command automatically. For more information, see [“STARTDB control statement”](#) on page 158.

**Note:** Defining a DBRC DB Group (database group) to which the HALDB master database and all HALDB partitions belong, and issuing the following command, makes it easier to start a HALDB:

```
/START DATAGROUP database_group_name ACCESS=xx
```





---

## Chapter 13. Smart Reorg reports

The Smart Reorg utility generates reports and messages, which help you understand the database health and troubleshoot problems.

### Topics:

- [“Report reference for Smart Reorg” on page 217](#)
- [“BBERPRT data set: Diagnosis report” on page 221](#)
- [“HPSOUT data set” on page 240](#)
- [“HPSOUT2 data set” on page 254](#)
- [“HPSLIST data set” on page 271](#)
- [“HPSSTAT data set” on page 271](#)
- [“BBEJRN data set” on page 279](#)
- [“BSNJM01 data set” on page 280](#)
- [“BBEERROR data set” on page 280](#)
- [“SEQERROR data set” on page 281](#)
- [“HPSTRACE data set” on page 281](#)
- [“HPSSNAP data set” on page 281](#)
- [“Reports produced by IMS Index Builder” on page 282](#)
- [“Reports produced by IMS HP Prefix Resolution” on page 282](#)
- [“Reports produced by IMS HP Image Copy” on page 282](#)
- [“Reports produced by IMS HP Pointer Checker” on page 282](#)

## Report reference for Smart Reorg

---

The Smart Reorg utility generates a variety of reports that provide information about database status and reorganization.

Subsections:

- [“Smart Reorg utility reports” on page 217](#)
- [“Smart Reorg utility reports in IMS Tools Knowledge Base” on page 220](#)
- [“Reports for problem determination” on page 220](#)
- [“Reports from optional tasks” on page 221](#)

### Smart Reorg utility reports

The following table lists the reports that the Smart Reorg utility generates and identifies the output data set that is associated with each report.

---

*Table 31. Report reference table for Smart Reorg*

Output data set	Report name	Description
BBERPRT	Database Diagnosis report or Partition Diagnosis report	The Diagnosis report provides the database statistics values that were retrieved in the database evaluation phase of a conditional reorganization job and the summary of the database status. When the database is reorganized in the conditional reorganization job, this report also contains the database statistics from the second evaluation phase.

---

Table 31. Report reference table for Smart Reorg (continued)

Output data set	Report name	Description
BBEERROR	Data Set Allocation Error - KEYLABEL report	This report contains information about the errors that occurred while allocating work data sets to obtain key labels.
	Data Set Deletion Error - KEYLABEL report	This report contains information about the errors that occurred while deleting work data sets that were allocated to obtain key labels.
HPSOUT	Environment report	The Environment report contains EXEC parameters that were specified for the job and the release levels of the operating system and IMS.
	Default Option Tables report	The Default Option Tables report contains contents of the System Default Option Table (HPSCOPTS) and the Installation Default Option Table (HPSCOPTI). If HPSCOPTI was used, this report contains information from both HPSCOPTS and HPSCOPTI. If HPSCOPTS was used, this report contains information only from HPSCOPTS.
	HPSIN Control Statements report	The HPSIN Control Statement report contains an echo of the control statements that you specified in the HPSIN data set. You can check the options that were activated for the parallel reorganization job.
	HALDB Process Summary report	The HALDB Process Summary report contains HALDB processing information.
	Segment Count Summary report (Unload task)	The Segment Count Summary report for Unload task provides the output segment occurrences of each segment type.
	Segment Count Summary report (Reload task)	The Segment Count Summary report for Reload task provides the balance between input and output segment occurrences of each segment type.
	WFP Process Summary report (Reload task)	The WFP Process Summary report for the Reload task summarizes information about the WFP data sets that are created for rebuilding PSINDEXes.

Table 31. Report reference table for Smart Reorg (continued)

Output data set	Report name	Description
HPSOUT2	Decoded DBD report	The Decoded DBD report contains the resulting DBD sources statements when the DECODEDBD and DECODESXD control statements request that the original DBDs be decoded.
	Decoded New DBD report	The Decoded New DBD report contains the resulting DBD source statements when the DECODEDBD and DECODESXD control statements request that the new DBDs be decoded.
	DBRC Authorization Processing for Reorganization report	The DBRC Authorization Processing for Reorganization report contains the DBRC authorization processing information.
	Result of Shadow Space Allocation report	The Result of Shadow Space Allocation report contains the result of deleting and allocating DASD space for shadow data sets.
	Result of PSINDEX Copy report	The Result of PSINDEX Copy report contains the output from IDCAMS commands that were issued for copying the PSINDEX records from the existing data sets to the new data sets.
	Data Set Information report	The Data Set Information report contains the names of the input and output database data sets and RECON data sets that were used in the parallel reorganization job.
	DBRC Authorization Processing for Name Swapping report	The DBRC Authorization Processing for Name Swapping report contains the DBRC authorization processing information for name swapping.
	Result of Name Swapping report	The Result of Name Swapping report contains the output from IDCAMS commands that were issued during data set name swapping.
	IDCAMS Command Stream for Name Swapping report	The IDCAMS Command Stream for Name Swapping report contains the IDCAMS commands that should be used in the manual data set name swapping.
	DBRC Notification Processing report	The DBRC Notification Processing report contains the DBRC notification processing information.
	IDCAMS Command Stream for Recovery from Name Swap Error report	The IDCAMS Command Stream for Recovery from Name Swap Error report contains the IDCAMS command stream that is generated by Reorganization Manager.
	DBRC Notification Command Stream report	The DBRC Notification Command Stream report contains the DBRC commands that are required to notify DBRC of the reorganization and image copy when DBRC is active, when NAMESWAP=NO is specified, and when reorganization ends successfully.
	Result of Old Data Sets Deletion report	The Result of Old Data Sets Deletion report contains the result of deleting old original data sets with IDCAMS commands.
	Result of Renaming Old Data Sets report	The Result of Renaming Old Data Sets report contains the result of renaming old original data sets with IDCAMS commands.
DBRC processing for restoring authorization flags	The DBRC processing for restoring authorization flags report contains the DBRC processing information for restoring authorization flags.	
IMS Command Processing report	The IMS Command Processing report contains the IMS command processing information.	
HPSLIST	DB Call Statistics	The DB Call Statistics report provides statistics on the number of HSSR calls.
	CAB Statistics	The CAB Statistics report contains detailed CAB information for the data set that is referred to by each PCB.

Table 31. Report reference table for Smart Reorg (continued)

Output data set	Report name	Description
HPSSTAT	Data Set Statistics report	The Data Set Statistics report provides physical statistics on a database by each data set group.
	Segment Statistics report	The Segment Statistics report provides various information about all the segments in a database.
	Pointer Count Summary report	The Pointer Count Summary report contains a list of all the pointers to a user-specified target, and various totals for each segment pointer type.
	Pointer Statistics report	The Pointer Statistics report contains a list of all the pointers to a user-specified target, and various totals and ratios for each segment pointer type.

### Smart Reorg utility reports in IMS Tools Knowledge Base

When the Smart Reorg reports are stored in the Output repository of IMS Tools KB, the report names that are defined in IMS Tools KB are used for managing the reports. The following table lists the report names that are used in IMS Tools KB.

Table 32. Smart Reorg report names used in IMS Tools KB

Report name	Long title	Short title
Database Diagnosis report	RGE-Database Diagnosis Report	RGE-DB Diagnosis Report
Data Set Information report	RGE-Data Set Information	RGE-Data Set Information
Environment report	RGE-Environment	RGE-Environment
HALDB Process Summary report	RGE-HALDB Process Summary	RGE-HALDB Process Summary
HPSIN Control Statements report	RGE-HPSIN Control Statements	RGE-HPSIN Control Stmt
Partition Diagnosis report	RGE-Partition Diagnosis Report	RGE-Part Diagnosis Report
Segment Count Summary report (Reload task)	RGE-Segment Count Summary (Reload task)	RGE-Segment Count (RL)
Segment Count Summary report (Unload task)	RGE-Segment Count Summary (Unload task)	RGE-Segment Count (UL)

### Reports for problem determination

The following table summarizes the data sets that are provided for problem determination.

Table 33. Data sets for problem determination

Output data set	Content
BBEJRNL	Journal messages issued by DB Analyzer and DB Sensor of the CRSS.
BSNJM01	Journal messages issued by Policy Services, which is called by the CRSS.
SEQERROR	Segments in key sequence error that are detected in the Reload task and their hierarchical dependent segments.

Table 33. Data sets for problem determination (continued)

Output data set	Content
HPSTRACE	Trace information and diagnostics information for GG status codes that are returned to the Unload task.
HPSSNAP	<ul style="list-style-type: none"><li>• Snapshot of the DBDs</li><li>• Snapshot of the control blocks of HSSR Engine of the Unload task</li><li>• Snapshot of the DBD that is used to load the database</li></ul>

## Reports from optional tasks

Various reports are produced by optional tasks. See the following topics for more information:

- [“Reports produced by IMS Index Builder” on page 282](#)
- [“Reports produced by IMS HP Prefix Resolution” on page 282](#)
- [“Reports produced by IMS HP Image Copy” on page 282](#)
- [“Reports produced by IMS HP Pointer Checker” on page 282](#)

## BBERPRT data set: Diagnosis report

The BBERPRT data set contains Diagnosis reports that are generated by conditional reorganization jobs.

The Diagnosis report provides the database statistics values that were retrieved in the database evaluation phase of a conditional reorganization job and the summary of the database status. When the database is reorganized in the conditional reorganization job, this report also contains the database statistics from the second evaluation phase.

This report is generated when the CRSS is used in the job. Whether the report is printed or not is controlled by the PRINTRPRT option that is specified in the (CONDREORG) block. When the job is run for a non-HALDB database, the Database Diagnosis report is generated for the database, and when it is run for a HALDB partition, the Partition Diagnosis report is generated for the partition.

This report consists of several sections. It includes information about the job, such as how the job was run, how the space usage was evaluated, which policy was used for database evaluation, what types of database exceptions were detected, whether the exception was so severe that the database reorganization was necessary, and how the reorganization, if performed, changed the space usage.

The Diagnosis reports can be stored in the Output repository of the IMS Tools KB server. You can use the ISPF user interface that is provided by IMS Tools KB to search and view these reports. Copies of Diagnosis reports can be exported to a SYSOUT stream or to a sequential data set by using the batch report export utility that is provided by IMS Tools KB. For details about the batch report export utility, see the *IMS Tools Base IMS Tools Knowledge Base User's Guide and Reference*.

A Diagnosis report consists of the following sections:

- Summary of Database Definition section (for non-HALDB) or Summary of Partition Definition section (for HALDB)
- Summary of Policy Evaluation section
- Database Statistics section
  - Database Record Statistics subsection
  - Randomizing Statistics subsection (for HDAM and PHDAM)
  - Physical I/O Statistics subsection
- Data Set Statistics section
  - Volume and Extent Statistics subsection

- Data Set Space Usage Statistics subsection
- IMS Space Utilization Statistics subsection
- KEYLABEL Statistics subsection
- HISAM Statistics subsection (for HISAM and SHISAM)
- Primary Index Statistics section (for HIDAM and PHIDAM)
  - Index Space Utilization Statistics subsection
  - Volume and Extent Statistics subsection
  - Data Set Space Usage Statistics subsection
- KEYLABEL Statistics subsection
- Index Statistics subsection

## Summary of Database Definition section

This section of the report contains the summary of the database definition.

The information that is included in the Summary of Database Definition section is different based on the types of databases or partitions.

Subsections:

- [“HIDAM or HDAM database” on page 222](#)
- [“HISAM database” on page 222](#)
- [“SHISAM database” on page 223](#)
- [“PHIDAM or PHDAM partition” on page 223](#)
- [“Report field descriptions” on page 223](#)

### HIDAM or HDAM database

The following figure shows an example of the Summary of Database Definition section for a HIDAM database.

```

IMS DB Reorg Expert - V4R1      Database Diagnosis Report      Page:      1
5655-S35                       Date: 11/01/2023      Time: 15.05.25

Summary of Database Definition
-----
Database..... BKDB0207
Database Type..... HIDAM
Data Set Organization..... VSAM
Number of Data Set Groups..... 1

```

*Figure 39. Summary of Database Definition—HIDAM database*

### HISAM database

The Summary of Database Definition section for a HISAM database is the same as that for a HIDAM database except that it contains information about the overflow data set instead of number of data set groups.

The following figure shows an example of the Summary of Database Definition section for a HISAM database.

```

IMS DB Reorg Expert - V4R1      Database Diagnosis Report      Page:    1
5655-S35                       Date: 11/01/2023      Time: 14.03.56

Summary of Database Definition
-----
Database..... DBHD0260
Database Type..... HISAM
Data Set Organization..... VSAM
Overflow Data Set.....
YES

```

Figure 40. Summary of Database Definition—HISAM database

## SHISAM database

The Summary of Database Definition section for a SHISAM database is the same as that for a HISAM database except that because a SHISAM database has no overflow data set, this section does not show the information about an overflow data set.

The following figure shows an example of the Summary of Database Definition section for a SHISAM database.

```

IMS DB Reorg Expert - V4R1      Database Diagnosis Report      Page:    1
5655-S35                       Date: 11/01/2023      Time: 15.16.53

Summary of Database Definition
-----
Database..... HISMDB1
Database Type..... SHISAM
Data Set Organization..... VSAM

```

Figure 41. Summary of Database Definition—SHISAM database

## PHIDAM or PHDAM partition

The Summary of Database Definition section for a PHIDAM partition or a PHDAM partition is the same as that for a non-partitioned database except that it contains information about the name of the partition that was processed.

The following figure shows an example of the Summary of Database Definition section for a PHIDAM partition.

```

IMS DB Reorg Expert - V4R1      Partition Diagnosis Report      Page:    1
5655-S35                       Date: 11/01/2023      Time: 13.25.09

Summary of Partition Definition
-----
Database..... PHI00100
Database Type..... PHIDAM
Data Set Organization..... OSAM
Name of Partition Processed..... PHI001A
Number of Data Set Groups..... 3

```

Figure 42. Summary of Database Definition—PHIDAM partition

## Report field descriptions

The following information is provided in the Summary of Database Definition section:

### Database

Shows the name of the database.

### Database Type

Shows the type of the database.

### Data Set Organization

Shows the data set organization of database data set.

### Number of Data Set Groups

Shows the number of data set groups. This field is not included for HISAM databases.

### Overflow Data Set

Shows whether the overflow data sets exist. This field is included for HISAM databases.

### Name of Partition Processed

Shows the name of the partition that was processed. This field is included only for PHIDAM and PHDAM partitions.

## Summary of Policy Evaluation section

This section of the report summarizes the result of policy evaluation. By looking at this section, you can determine the status of the database or partition.

The Summary of Policy Evaluation section contains the following information:

- Information about the policy that was used in the job and the locale of the policy.
- Reorganization need. Whether reorganization is recommended for this database or partition.
- The database exceptions that were found during the first evaluation phase.
- When reorganization is processed, the database exceptions that were found during the second evaluation phase.
- A message that summarizes the result of policy evaluation. You can determine the required action from this message.

The Summary of Policy Evaluation section will be different based on the results of the first evaluation phase.

Subsections:

- [“When no database exceptions were detected” on page 224](#)
- [“When database exceptions were detected and database was reorganized” on page 224](#)
- [“Report field descriptions” on page 225](#)

### When no database exceptions were detected

The following figure shows an example of the Summary of Policy Evaluation section when no database exceptions were detected during the first evaluation phase.

```
IMS DB Reorg Expert - V4R1      Database Diagnosis Report      Page:      2
5655-S35                       Date: 11/01/2023      Time: 15.05.25

Summary of Policy Evaluation (DBD: BKDB0207)
-----
Name of Policy Applied..... SYS.DBDNAME.BKDB0207
Policy Locale..... RECON ID: RECON207
Reorganization Need..... No

Exceptions before Reorganization
-----
*** No exception was detected ***
-----
```

Figure 43. Summary of Policy Evaluation—no exceptions detected

### When database exceptions were detected and database was reorganized

The following figure shows an example of the Summary of Policy Evaluation section when database exceptions were detected during the first evaluation phase, and when the database was reorganized.



Summary of Policy Evaluation (DBD: BKDB )

-----  
 Name of Policy Applied..... SYS.DBDBTYPE.HIDAM  
 Policy Locale..... Global  
 Reorganization Need..... Yes

-----  
 Exceptions before Reorganization

-----  
 The number of available extents for a data set of BKDB is small  
 Class: DATA\_SET\_EXTENTS\_AVAILABILITY Level: CRITICAL  
 Rule: G:IBM.DBDS\_EXTENTS.10 Threshold Set: HIGH

The size of a data set in BKDB, which still has a certain amount of free space,  
 has increased  
 Class: GROWING\_DBDS\_WITH\_FREE\_SPACES Level: CRITICAL -> REORG  
 Rule: G:IBM.DBDS\_GROWTH.20 Threshold Set: HIGH

The fragmentation of free space in BKDB has increased  
 Class: FRAGMENTED\_FREE\_SPACES Level: CRITICAL -> REORG  
 Rule: G:IBM.FRAGMENTATION.10 Threshold Set: HIGH

A data set of BKDB has many pointers that point to other blocks or CIs  
 Class: EXCESSIVE\_SEGMENT\_SCATTERING Level: SEVERE  
 Rule: G:IBM.SEGM\_SPREAD.10 Threshold Set: MED

-----  
 Exceptions after Reorganization

-----  
 BSN2800I GENERAL STATUS: RESOURCE=BKDB ACTION\_NAME=REORG  
 EXECUTION\_STATUS=SUCCESSFUL

The number of available extents for a data set of BKDB is small  
 Class: DATA\_SET\_EXTENTS\_AVAILABILITY Level: CRITICAL  
 Rule: G:IBM.DBDS\_EXTENTS.10 Threshold Set: HIGH

-----  
 Summary of Policy Evaluation and Action:

-----  
 BBE2904I BKDB IN RECONID=RECON207 HAS BEEN REORGANIZED, BUT IS STILL IN A  
 CRITICAL STATE.  
 -----

Figure 44. Summary of Policy Evaluation—exceptions detected and reorganized

## Report field descriptions

The following information is provided in the Summary of Policy Evaluation section:

### Name of Policy Applied

Shows the name of the policy that was used in the evaluation phases.

### Policy Locale

Shows the locale where the policy was found. When the policy was found in the RECON-specific locale, the RECON ID for the locale is printed in this field. When the policy is found in the global locale, Global is printed in this field.

### Reorganization Need

Shows the recommended action based on the result of the first evaluation phase.

#### Yes

When REORG is printed one or more times in the Exceptions before Reorganization section, Yes is displayed in this field. This response indicates that the reorganization is recommended to resolve the exceptions for which REORG is displayed because these exceptions can be removed by simply unloading and reloading data. For other exceptions, further actions, such as changing the database definition or changing the data set space allocation, might be needed to resolve the exceptions. For details about addressing these exceptions, see [Chapter 11, “Working with policies and database exceptions,”](#) on page 205.

**No**

When REORG is not printed in the Exceptions before Reorganization section, No is displayed in this field. This response indicates that the database or the HALDB partition is in either of the following states:

- Space utilization is not in a critical state. The database or the HALDB partition does not require reorganization.
- Space utilization needs to be improved. However, simply unloading and reloading data will not improve the state of space utilization.

**Exceptions before Reorganization**

Shows the message that is mapped to the class and the level of the exception that was detected during the first evaluation phase. This information is provided for each exception that was detected.

**Class**

Shows the name of the exception class.

**Level**

Shows the exception severity level. This value is WARNING, SEVERE, or CRITICAL.

When the CRSS determines that the database or partition requires reorganization, -> REORG is displayed on the left of the exception class and level.

**Rule**

Shows the name of the rule that detected this exception. A rule has either of the following prefixes:

**G**

Indicates that the rule was retrieved from the global locale.

**R**

Indicates that the rule was retrieved from the RECON-specific locale that is identified by the RECON ID displayed on the Policy Locale field.

**Threshold set**

Show the name of the threshold set that was used to detect this exception.

**Exceptions after Reorganization**

Shows the message that is mapped to the class and the level of the exception that was detected during the second evaluation phase. This information is provided for each exception that is detected.

**Class**

Shows the name of the exception class.

**Level**

Shows the exception severity level. This value is WARNING, SEVERE, or CRITICAL.

**Rule**

Shows the name of the rule that detected this exception. A rule has either of the following prefixes:

**G**

Indicates that the rule was retrieved from the global locale.

**R**

Indicates that the rule was retrieved from the RECON-specific locale that is identified by the RECON ID displayed on the Policy Locale field.

**Threshold set**

Show the name of the threshold set that was used to detect this exception.

When the database exceptions found in the second evaluation phase meet the conditions to reorganize, -> REORG is displayed. However, reorganization is not processed for the second time.

This field is included only when the database or partition was reorganized.

**Summary of Policy Evaluation and Action**

Shows the summary of the job and the status of the database or partition.

This field shows the policy evaluation summary message that was issued by the Policy Services Action Manager component. The message includes the database or partition name, the action that was taken, and, if the database was reorganized, the result of the reorganization process.

It can be one of the following messages:

- BBE2900I *resource\_name* IN RECONID=*recon\_id* HAS BEEN REORGANIZED, AND NO EXCEPTIONS WERE DETECTED AFTER THE REORG.
- BBE2901I *resource\_name* IN RECONID=*recon\_id* HAS BEEN REORGANIZED, BUT SOME WARNING EXCEPTIONS REMAIN.
- BBE2902I *resource\_name* IN RECONID=*recon\_id* HAS WARNING EXCEPTIONS IN THE REORG DOMAIN.
- BBE2903I *resource\_name* IN RECONID=*recon\_id* HAS BEEN REORGANIZED, BUT IS STILL IN A "REORG NEEDED" STATE.
- BBE2904I *resource\_name* IN RECONID=*recon\_id* HAS BEEN REORGANIZED, BUT IS STILL IN A CRITICAL STATE.
- BBE2905I *resource\_name* IN RECONID=*recon\_id* HAS CRITICAL EXCEPTIONS IN THE REORG DOMAIN. USER ACTION IS REQUIRED.
- BBE2906I THE REORGANIZATION OF *resource\_name* IN RECONID=*recon\_id* WAS ATTEMPTED AND FAILED.
- BBE2907I *resource\_name* IN RECONID=*recon\_id* HAS BEEN REORGANIZED, BUT IS STILL IN A SEVERE STATE.
- BBE2908I *resource\_name* IN RECONID=*recon\_id* HAS SEVERE EXCEPTIONS IN THE REORG DOMAIN.
- BBE2909I *resource\_name* IN RECONID=*recon\_id* HAS BEEN REORGANIZED, BUT ITS STATUS IS UNAVAILABLE.
- BBE2910I ACTION "REORG" IS RECOMMENDED FOR *resource\_name* IN RECONID=*recon\_id*.

**Note:** *resource\_name* shows the database or partition name, and *recon\_id* shows the 8 byte RECON ID that is defined to IMS Tools Knowledge Base.

For the explanation about the Smart Reorg utility actions and the actions you must take, see [“Checking the policy evaluation summary message” on page 205.](#)

## Database Record Statistics section

This section of the report contains detailed information about database record statistics.

The Database Record Statistics section shows the database record statistics for each data element.

Subsections:

- [“HDAM, HIDAM, HISAM, or SHISAM database” on page 227](#)
- [“PHIDAM or PHDAM partition” on page 228](#)
- [“Report field descriptions” on page 228](#)

### HDAM, HIDAM, HISAM, or SHISAM database

The following figure shows an example of the Database Record Statistics section for a HIDAM database.

```

IMS DB Reorg Expert - V4R1      Database Diagnosis Report      Page: 3
5655-S35                      Date: 11/01/2023      Time: 00.05.14

Database Statistics (DBD: BKDB )
-----
=====
                Database Record Statistics
=====

Note: The mark * in column P means that the data element is used in the policy.

Data Element Name      P      Before Reorg      After Reorg      Difference
-----
DB_NUM_ROOT            *      8,560,000          8,560,000          0
DB_AVG_DBREC_LENGTH   *           288.06            288.06             0

```

Figure 45. Database Record Statistics—HIDAM database

## PHIDAM or PHDAM partition

For a PHIDAM partition or a PHDAM partition, the name of the partition that was processed is displayed on the subtitle of each logical page.

The following figure shows an example of the Database Record Statistics section for a PHIDAM partition.

```

IMS DB Reorg Expert - V4R1      Partition Diagnosis Report      Page: 3
5655-S35                      Date: 11/01/2023      Time: 13.25.09

Database Statistics (DBD: PHI00100, Partition: PHI001A)
-----
=====
                Database Record Statistics
=====

Note: The mark * in column P means that the threshold is used in the policy.

Data Element Name      P      Before Reorg      After Reorg      Difference
-----
DB_NUM_ROOT            *      8,560,000          8,560,000          0
DB_AVG_DBREC_LENGTH   *           288.06            288.06             0

```

Figure 46. Database Record Statistics—PHIDAM partition

## Report field descriptions

The following information is provided in the Database Record Statistics section:

### Data Element Name

Shows the names of the data elements that represent statistics information about database records.

### P

Shows whether the data element was used during the policy evaluation phases. An asterisk (\*) indicates that the data element was used.

### Before Reorg

Shows the database record statistics for the data element. This value shows the statistics that were collected in the first evaluation phase.

### After Reorg

Shows the database record statistics for the data element. This value shows the statistics that were collected in the second evaluation phase. When the database or partition is not reorganized, n/a is displayed in this field.

### Difference

Shows the difference in statistics data between Before Reorg and After Reorg. When the database or partition is not reorganized, n/a is displayed in this field.

## Randomizing Statistics section (HDAM and PHDAM)

This section of the report contains detailed information about randomizing statistics. This section is included only for HDAM and PHDAM databases.

The following figure shows an example of the Randomizing Statistics section for an HDAM database.

```

IMS DB Reorg Expert - V4R1      Database Diagnosis Report      Page: 4
5655-S35                      Date: 11/01/2023      Time: 15.05.25

Database Statistics (DBD: DBHD1330)
-----
                        =====
                        Randomizing Statistics
                        =====

Note: The mark * in column P means that the data element is used in the policy.

Data Element Name      P      Before Reorg      After Reorg      Difference
-----
DB_NUM_RAP              450,015      450,015      0
DB_NUM_UNUSED_RAP      330,016      330,016      0
DB_PCT_NUM_UNUSED_RAP  73%          73%          0
DB_NUM_SYNONYM         30,001      30,001      0
DB_PCT_NUM_SYNONYM     *           20%          20%          0
DB_AVG_LEN_SYNONYM_CHAIN 2.00         2.00         0
DB_NUM_ROOT_NOHOME     46,960      40,026      -6,934
DB_PCT_NUM_ROOT_NOHOME *           31%          27%          -4
DB_PCT_BYTES_OVFL      *           0%           0%           0
DB_NUM_ROOT_OVFL       0           0           0
DB_PCT_NUM_ROOT_OVFL  *           0%           0%           0
DB_BYTES_SEG_RAA      106,436,000 106,436,000 0
DB_FLAG_SENSOR_HOME    Y           Y           No change
  
```

Figure 47. Randomizing Statistics

### Report field descriptions

The following information is provided In the Randomizing Statistics section:

#### Data Element Name

Shows the names of the data elements that represent information about database randomizing statistics.

#### P

Shows whether the data element was used during the policy evaluation phases. An asterisk (\*) indicates that the data element was used.

#### Before Reorg

Shows the randomizing statistics for the data element. This value shows the statistics that were collected in the first evaluation phase.

#### After Reorg

Shows the randomizing statistics for the data element. This value shows the statistics that were collected in the second evaluation phase. When the database or partition is not reorganized, n/a is displayed in this field.

#### Difference

Shows the difference in statistics data between Before Reorg and After Reorg. When the database or partition is not reorganized, n/a is displayed in this field.

## Physical I/O Statistics section

This section of the report contains detailed information about physical I/O statistics.

The following figure shows an example of the Physical I/O Statistics section for an HDAM database.

Database Statistics (DBD: ITHDAM01)

```

=====
Physical I/O Statistics
=====
    
```

Note: The mark \* in column P means that the data element is used in the policy.

Data Element Name	P	Before Reorg	After Reorg	Difference
DB_ESTIMATED_DBREC_IO		1.78	1.78	0
DB_ESTIMATED_ROOT_IO		1.26	1.26	0

Figure 48. Physical I/O Statistics

## Report field descriptions

The following information is provided in the Physical I/O Statistics section:

### Data Element Name

Shows the names of the data elements that represent statistics information about physical I/O.

### P

Shows whether the data element was used during the policy evaluation phases. An asterisk (\*) indicates that the data element was used.

### Before Reorg

Shows the physical I/O statistics for the data element. This value shows the statistics that were collected in the first evaluation phase.

### After Reorg

Shows the physical I/O statistics for the data element. This value shows the statistics that were collected in the second evaluation phase. When the database or partition is not reorganized, n/a is displayed in this field.

### Difference

Shows the difference in statistics data between Before Reorg and After Reorg. When the database or partition is not reorganized, n/a is displayed in this field.

## Volume and Extent Statistics section

This section of the report contains statistics about the volume and extent usage of the data set.

The Volume and Extent Statistics section shows the data set allocation information through available extents on volumes that are assigned to the data set. When a database is composed of more than one data set group, this section is provided for each data set group of the database.

This section of the report contains the following three blocks:

- Data set definition and environment information
- Data set usage information
- Remaining available data set extent estimation

The following figure shows an example of the Volume and Extent Statistics section for a HIDAM database.

Data Set Statistics (DBD: BKDB , DSG: 01)

```

=====
Volume/Extent Statistics
=====
    
```

Note: The mark \* in column P means that the data element is used in the policy.

Data set definition and environment information

```

=====
Data Element Name      P      Before Reorg      After Reorg      Difference
-----
DB_FLAG_SPACE_TYPE          C          C          No change
DB_NUM_PRI_SPACE          1,000      1,000          0
DB_NUM_SEC_SPACE          100        100          0
DB_FLAG_SMS                *          Y          Y          No change
DB_MAX_EXT_DS             251        251          0
DB_MAX_EXT_VOL            123        123          0
    
```

Data set usage information

```

=====
Data Element Name      P      Before Reorg      After Reorg      Difference
-----
DB_NUM_EXT                37         32          -5
DB_NUM_VOL                3          3           0
DB_NUM_UNUSED_VOL        0          0           0
DB_NUM_UNUSED_VOL_SER    0          0           0
DB_NUM_UNUSED_VOL_CAND  *          0           0           0
    
```

Remaining available data set extent estimation

```

=====
Data Element Name      P      Before Reorg      After Reorg      Difference
-----
DB_AVAIL_EXT_LESS_100    *          Y          Y          No change
DB_NUM_AVAIL_EXT        *          0          11         +11
DB_AVAIL_EXT_LIMIT      VOL_FREE_EXTENTS VOL_FREE_EXTENTS No change
    
```

Remark: If DB\_NUM\_UNUSED\_VOL\_CAND is not zero, more extents than those indicated by DB\_NUM\_AVAIL\_EXT might be available.

Figure 49. Volume and Extent Statistics

## Report field descriptions

The following information is provided in the Volume and Extent Statistics section:

### Data Element Name

Shows the names of the data elements that represent statistics information about volume and extent usage.

### P

Shows whether the data element was used during the policy evaluation phases. An asterisk (\*) indicates that the data element was used.

### Before Reorg

Shows the volume and extent statistics for the data element. This value shows the statistics that were collected in the first evaluation phase.

### After Reorg

Shows the volume and extent statistics for the data element. This value shows the statistics that were collected in the second evaluation phase. When the database or partition is not reorganized, n/a is displayed for this field.

### Difference

Shows the difference in statistics data between Before Reorg and After Reorg. When the database or partition is not reorganized, n/a is displayed in this field.

### Remaining available data set extent estimation

This field reports the following three data element values:

- DB\_AVAIL\_EXT\_LESS\_100

Shows whether the number of remaining extents to be allocated for the data set is less than 100 or not. Y indicates that it is less than 100.

- DB\_NUM\_AVAIL\_EXT

Shows the number of estimated extents for this data set on extendible volumes.

- If DB\_AVAIL\_EXT\_LESS\_100 is Y, this field shows the actual value that was collected by DB Sensor.
- If DB\_AVAIL\_EXT\_LESS\_100 is N, this field shows >100.
- If DB\_AVAIL\_EXT\_LESS\_100 is n/a, this field shows n/a.

- DB\_AVAIL\_EXT\_LIMIT

When the number of remaining extents is evaluated to be less than 100, this element shows what is limiting the upper boundary. The upper boundary is the number of maximum allowable extents that is determined by VSAM\_MAXIMUM, OSAM\_MAXIMUM, or VOL\_FREE\_EXTENTS. This information can help you determine the best way to address expanding space.

- VSAM\_MAXIMUM and OSAM\_MAXIMUM mean that the number of extents that are available is limited by the maximum number of extents that can be allocated for a data set of that data set organization.
- VOL\_FREE\_EXTENTS means that the number of extents that are available is limited by the maximum number of extents that can be allocated on each DASD volume.

## Data Set Space Usage Statistics section

This section of the report contains statistics about data set space usage.

When a database is composed of more than one data set group, this section is provided for each data set group of the database.

The following figure shows an example of the Data Set Space Usage Statistics section for a HIDAM database.

```

IMS DB Reorg Expert - V4R1      Database Diagnosis Report      Page:    6
5655-S35                       Date: 11/01/2023      Time: 00.05.14

Data Set Statistics (DBD: BKDB      , DSG: 01)
-----
                        =====
                        Data Set Space Usage Statistics
                        =====
Note: The mark * in column P means that the data element is used in the policy.

Data Element Name      P      Before Reorg      After Reorg      Difference
-----
DB_BLOCK_SIZE          4,096          4,096          0
DB_NUM_DBDS_BLOCKS    999,179      673,780      -325,399
DB_MAX_DS_SIZE        4G            4G            0G
DB_PCT_OF_MAX_DS_SIZE *      96%          65%          -31
DB_RBA_HIGH_ALLOC     4,128,768,000  2,801,664,000 -1,327,104,000
DB_RBA_HIGH_USED      4,092,641,280  2,759,806,976 -1,332,834,304
DB_UNUSED_BYTES       8,192         14,336         +6,144
DB_PCT_UNUSED_BYTES   1%            1%            0

```

Figure 50. Data Set Space Usage Statistics

### Report field descriptions

The following information is provided in the Data Set Space Usage Statistics section:

#### Data Element Name

Shows the names of the data elements that represent statistics information about data set space usage.



**P**

Shows whether the data element was used during the policy evaluation phases. An asterisk (\*) indicates that the data element was used.

**Before Reorg**

Shows the space usage statistics for the data element. This value shows the statistics that were collected in the first evaluation phase.

**After Reorg**

Shows the space usage statistics for the data element. This value shows the statistics that were collected in the second evaluation phase. When the database or partition is not reorganized, n/a is displayed in this field.

**Difference**

Shows the difference in statistics data between Before Reorg and After Reorg. When the database or partition is not reorganized, n/a is displayed in this field.

## IMS Space Utilization Statistics section

This section of the report contains statistics about IMS space utilization.

The IMS Space Utilization Statistics section summarizes the IMS space utilization statistics. When a database is composed of more than one data set group, this section is provided for each data set group of the database.

The following figure shows an example of the IMS Space Utilization Statistics section for a HIDAM database.

```

IMS DB Reorg Expert - V4R1      Database Diagnosis Report      Page: 7
5655-S35                       Date: 11/01/2023      Time: 00.05.14

Data Set Statistics (DBD: BKDB , DSG: 01)
-----
                    =====
                    IMS Space Utilization Statistics
                    =====
Note: The mark * in column P means that the data element is used in the policy.

Data Element Name      P      Before Reorg      After Reorg      Difference
-----
DB_BYTES_SEG           -      2,465,800,000    2,465,800,000      0
DB_BYTES_FREE_SPACE    -      1,610,723,680    283,136,678        -1,327,587,002
DB_BYTES_UNIDENTIFIED  *              110                0                   -110
DB_PCT_BYTES_FREE_SPACE *             39%                10%                 -29
DB_PCT_BYTES_SEG       *             60%                89%                 +29
DB_NUM_SEG             -      85,620,000       85,620,000         0
DB_NUM_VLSEG           -      8,560,000        8,560,000         0
DB_NUM_VLSEG_SPLIT    *              0                  0                   0
DB_PCT_NUM_VLSEG_SPLIT *             0%                0%                  0
DB_NUM_UNIDENTIFIED   *             51                 0                   -51
DB_AVG_NUM_UNIDENTIFIED *            0                  0                   0
DB_NUM_FSE             *      23,728,638       673,759            -23,054,879
DB_AVG_NUM_FSE        *           23.75             1.00                -22.75
DB_NUM_FSE_MIN        *      23,558,660       673,759            -22,884,901
DB_NUM_FSE_MAX        *       718,662         673,759            -44,903
DB_AVG_NUM_NOREUSE_FSE *            .17                0                   - .17
DB_PCT_NUM_NOREUSE_FSE *             1%                0%                  -1
DB_AVG_NUM_FRAGD_FSE  -      23.03             0                   -23.03
DB_PCT_NUM_FRAGD_FSE  -             97%               0%                  -97
DB_NUM_PTR            -      85,070,408       84,946,241         -124,167
DB_NUM_PTR_DIFF_BLK   *      32,424,879       663,666            -31,761,213
DB_PCT_NUM_PTR_DIFF_BLK *             38%                1%                  -37

```

Figure 51. IMS Space Utilization Statistics

### Report field descriptions

The following information is provided in the Volume and Extent Statistics section:

**Data Element Name**

Shows the names of the data elements that represent statistics information about IMS space utilization.

**P**

Shows whether the data element was used during the policy evaluation phases. An asterisk (\*) indicates that the data element was used.

**Before Reorg**

Shows the IMS space utilization statistics for the data element. This value shows the statistics that were collected in the first evaluation phase.

**After Reorg**

Shows the IMS space utilization statistics for the data element. This value shows the statistics that were collected in the second evaluation phase. When the database or partition is not reorganized, n/a is displayed in this field.

**Difference**

Shows the difference in statistics data between Before Reorg and After Reorg. When the database or partition is not reorganized, n/a is displayed in this field.

## KEYLABEL Statistics section

This section of the report contains information about the key labels.

The following figure shows an example of the KEYLABEL Statistics section.

```

IMS DB Reorg Expert - V4R1      Database Diagnosis Report      Page: 10
5655-S35                        Date: 06/16/2024      Time: 19.55.00

Data Set Statistics (DBD: DBHD1250, DSG: 01)
-----
                               =====
                               KEYLABEL Statistics
                               =====
-----
Before      IMST.AES256.SECURE
After      H25N.AES256.SECURE

```

Figure 52. KEYLABEL Statistics

### Report field descriptions

The following information is provided in the KEYLABEL Statistics section:

**Before**

Shows the key labels of the database data sets before reorganization.

**After**

Shows the key labels of the database data sets after reorganization.

## HISAM Statistics section (HISAM and SHISAM)

This section of the report contains the statistics for a HISAM database. This section is provided only for HISAM and SHISAM databases.

The following figure shows an example of the HISAM Statistics section.

Data Set Statistics (DBD: DBHD0260, Primary Data Set)

=====

HISAM Statistics

=====

Note: The mark \* in column P means that the data element is used in the policy.

Data Element Name	P	Before Reorg	After Reorg	Difference
DB_NUM_CI_SPLIT		60	0	-60
DB_PCT_NUM_CI_SPLIT	*	20%	0%	-20
DB_NUM_CA_SPLIT		8	0	-8
DB_PCT_NUM_CA_SPLIT	*	67%	0%	-67
DB_NUM_DELSEG		0	0	0
DB_PCT_NUM_DELSEG	*	0%	0%	0
DB_LRECL_SIZE		15,016	15,016	0

Figure 53. HISAM Statistics

### Report field descriptions

The following information is provided in the HISAM Statistics section:

#### Data Element Name

Shows the names of the data elements that represent statistics information about HISAM database.

#### P

Shows whether the data element was used during the policy evaluation phases. An asterisk (\*) indicates that the data element was used.

#### Before Reorg

Shows the HISAM statistics for the data element. This value shows the statistics that were collected in the first evaluation phase.

#### After Reorg

Shows the HISAM statistics for the data element. This value shows the statistics that were collected in the second evaluation phase. When the database or partition is not reorganized, n/a is displayed in this field.

#### Difference

Shows the difference in statistics data between Before Reorg and After Reorg. When the database or partition is not reorganized, n/a is displayed in this field.

## Index Space Utilization Statistics section (HIDAM and PHIDAM)

This section of the report contains statistics about index space utilization. This section is included only for HIDAM and PHIDAM databases.

Subsections:

- [“HIDAM database” on page 235](#)
- [“PHIDAM primary index” on page 236](#)
- [“Report field descriptions” on page 236](#)

### HIDAM database

The following figure shows an example of the Index Space Utilization Statistics section for an HIDAM database.

Database Statistics (DBD: INDEX01)

=====  
 Index Space Utilization Statistics  
 =====

Note: The mark \* in column P means that the data element is used in the policy.

Data Element Name	P	Before Reorg	After Reorg	Difference
DBX_NUM_IPS		260	260	0
DBX_NUM_IPS_OVFL		n/a	n/a	n/a
DBX_PCT_IPS_OVFL		n/a	n/a	n/a

Figure 54. Index Space Utilization Statistics—HIDAM database

For an HIDAM database, the DBD name of the primary index is displayed in the subtitle of each logical page.

### PHIDAM primary index

The following figure shows an example of the Index Space Utilization Statistics section for a PHIDAM database.

Partition Statistics (DBD: ITHIDM01, Partition: ITHIDMA)

=====  
 Index Space Utilization Statistics  
 =====

Note: The mark \* in column P means that the data element is used in the policy.

Data Element Name	P	Before Reorg	After Reorg	Difference
DBX_NUM_IPS		260	260	0
DBX_NUM_IPS_OVFL		n/a	n/a	n/a
DBX_PCT_IPS_OVFL		n/a	n/a	n/a

Figure 55. Index Space Utilization Statistics—PHIDAM database

For PHIDAM partitions, the DBD name of the PHIDAM database and the name of the partition that was processed are displayed in the subtitle of each logical page.

### Report field descriptions

The following information is provided in the Index Space Utilization Statistics section:

#### Data Element Name

Shows the names of the data elements that represent statistics information about index space utilization.

#### P

Shows whether the data element was used during the policy evaluation phases. An asterisk (\*) indicates that the data element was used.

#### Before Reorg

Shows the index space utilization statistics for the data element. This value shows the statistics that were collected in the first evaluation phase.

#### After Reorg

Shows the index space utilization statistics for the data element. This value shows the statistics that were collected in the second evaluation phase. When the database or partition is not reorganized, n/a is displayed in this field.

## Difference

Shows the difference in statistics data between Before Reorg and After Reorg. When the database or partition is not reorganized, n/a is displayed in this field.

## Volume and Extent Statistics section (Primary Index)

This section of the report contains statistics about the volume and extent usage of a primary index data set. This section is included only for HIDAM and PHIDAM databases.

The Volume and Extent Statistics section shows the data set allocation information through available extents on the volumes that are assigned to the primary index data set.

This section of the report contains the following three blocks:

- Data set definition and environment information
- Data set usage information
- Remaining available data set extent estimation

The following figure shows an example of the Volume and Extent Statistics section for an HIDAM primary index.

```
IMS DB Reorg Expert - V4R1      Database Diagnosis Report      Page: 9
5655-S35                        Date: 11/01/2023      Time: 12.09.07

Data Set Statistics (DBD: INDEX01 , Primary Index Data Set)
-----
                        =====
                        Volume/Extent Statistics
                        =====

Note: The mark * in column P means that the data element is used in the policy.

Data set definition and environment information
=====
Data Element Name      P      Before Reorg      After Reorg      Difference
-----
DBX_FLAG_SPACE_TYPE          T          T          No change
DBX_NUM_PRI_SPACE           1          1          0
DBX_NUM_SEC_SPACE           1          1          0
DBX_FLAG_SMS                 N          N          No change
DBX_MAX_EXT_DS              251        251         0
DBX_MAX_EXT_VOL             123        123         0

Data set usage information
=====
Data Element Name      P      Before Reorg      After Reorg      Difference
-----
DBX_NUM_EXT                32         48          +16
DBX_NUM_VOL                 1          1           0
DBX_NUM_UNUSED_VOL         0          0           0
DBX_NUM_UNUSED_VOL_SER     0          0           0
DBX_NUM_UNUSED_VOL_CAND    0          0           0

Remaining available data set extent estimation
=====
Data Element Name      P      Before Reorg      After Reorg      Difference
-----
DBX_AVAIL_EXT_LESS_100          Y          Y          No change
DBX_NUM_AVAIL_EXT             91         75          -16
DBX_AVAIL_EXT_LIMIT           VSAM_MAXIMUM VSAM_MAXIMUM No change

Remark: If DB_NUM_UNUSED_VOL_CAND is not zero, more extents than those
indicated by DB_NUM_AVAIL_EXT might be available.
```

Figure 56. Volume and Extent Statistics

## Report field descriptions

The following information is provided in the Volume and Extent Statistics section:

### Data Element Name

Shows the names of the data elements that represent statistics information about volume and extent usage.

## P

Shows whether the data element was used during the policy evaluation phases. An asterisk (\*) indicates that the data element was used.

### **Before Reorg**

Shows the volume and extent statistics for the data element. This value shows the statistics that were collected in the first evaluation phase.

### **After Reorg**

Shows the volume and extent statistics for the data element. This value shows the statistics that were collected in the second evaluation phase. When the database or partition is not reorganized, n/a is displayed for this field.

### **Difference**

Shows the difference in statistics data between Before Reorg and After Reorg. When the database or partition is not reorganized, n/a is displayed in this field.

### **Remaining available data set extent estimation**

This field reports the following three data element values:

- **DBX\_AVAIL\_EXT\_LESS\_100**

Shows whether the number of remaining extents to be allocated for the data set is less than 100 or not. Y indicates that it is less than 100.

- **DBX\_NUM\_AVAIL\_EXT**

Shows the number of estimated extents for this data set on extendible volumes.

- If **DBX\_AVAIL\_EXT\_LESS\_100** is Y, this field shows the actual value that was collected by DB Sensor.

- If **DBX\_AVAIL\_EXT\_LESS\_100** is N, this field shows >100.

- If **DBX\_AVAIL\_EXT\_LESS\_100** is n/a, this field shows n/a.

- **DBX\_AVAIL\_EXT\_LIMIT**

When the number of remaining extents is evaluated to be less than 100, this element shows what is limiting the upper boundary. The upper boundary is the number of maximum allowable extents that is determined by **VSAM\_MAXIMUM**, **OSAM\_MAXIMUM**, or **VOL\_FREE\_EXTENTS**. This information can help you determine the best way to address expanding space.

- **VSAM\_MAXIMUM** and **OSAM\_MAXIMUM** mean that the number of extents that are available is limited by the maximum number of extents that can be allocated for a data set of that data set organization.

- **VOL\_FREE\_EXTENTS** means that the number of extents that are available is limited by the maximum number of extents that can be allocated on each DASD volume.

## **Data Set Space Usage Statistics section (Primary Index)**

This section of the report contains statistics about the space usage of a primary index data set. This section is included only for HIDAM and PHIDAM databases.

The following figure shows an example of the Data Set Space Usage Statistics section for an HIDAM primary index.

Data Set Statistics (DBD: INDEX01 , Primary Index Data Set)

```

=====
Data Set Space Usage Statistics
=====
    
```

Note: The mark \* in column P means that the data element is used in the policy.

Data Element Name	P	Before Reorg	After Reorg	Difference
DBX_BLOCK_SIZE		2,048	2,048	0
DBX_NUM_DBDS_BLOCKS		671	1,000	+329
DBX_MAX_DS_SIZE		4G	4G	0G
DBX_PCT_OF_MAX_DS_SIZE		0%	0%	0
DBX_RBA_HIGH_ALLOC		1,376,256	2,064,384	+688,128
DBX_RBA_HIGH_USED		1,376,256	2,050,048	+673,792
DBX_UNUSED_BYTES		8,192	14,336	+6,144
DBX_PCT_UNUSED_BYTES		1%	1%	0

Figure 57. Data Set Space Usage Statistics

### Report field descriptions

The following information is provided in the Data Set Space Usage Statistics section:

#### Data Element Name

Shows the names of the data elements that represent statistics information about data set space usage.

#### P

Shows whether the data element was used during the policy evaluation phases. An asterisk (\*) indicates that the data element was used.

#### Before Reorg

Shows the space usage statistics for the data element. This value shows the statistics that were collected in the first evaluation phase.

#### After Reorg

Shows the space usage statistics for the data element. This value shows the statistics that were collected in the second evaluation phase. When the database or partition is not reorganized, n/a is displayed in this field.

#### Difference

Shows the difference in statistics data between Before Reorg and After Reorg. When the database or partition is not reorganized, n/a is displayed in this field.

## Index Statistics section (Primary Index)

This section of the report contains the statistics for a primary index data set. This section is included only for HIDAM and PHIDAM database.

The following figure shows an example of the Index Statistics section for an HIDAM primary index.

Data Set Statistics (DBD: INDEX01 , Primary Index Data Set)

```

=====
Index Statistics
=====
    
```

Note: The mark \* in column P means that the data element is used in the policy.

Data Element Name	P	Before Reorg	After Reorg	Difference
DBX_NUM_CI_SPLIT		0	0	0
DBX_PCT_NUM_CI_SPLIT		0%	0%	0%
DBX_NUM_CA_SPLIT		0	0	0
DBX_PCT_NUM_CA_SPLIT		0%	0%	0%
DBX_LRECL_SIZE		16	16	0

Figure 58. Index Statistics

## Report field descriptions

The following information is provided in the Index Statistics section:

### Data Element Name

Shows the names of the data elements that represent statistics information about index.

### P

Shows whether the data element was used during the policy evaluation phases. An asterisk (\*) indicates that the data element was used.

### Before Reorg

Shows the index statistics for the data element. This value shows the statistics that were collected in the first evaluation phase.

### After Reorg

Shows the index statistics for the data element. This value shows the statistics that were collected in the second evaluation phase. When the database or partition is not reorganized, n/a is displayed in this field.

### Difference

Shows the difference in statistics data between Before Reorg and After Reorg. When the database or partition is not reorganized, n/a is displayed in this field.

## HPSOUT data set

The HPSOUT data set is the primary statistics output data set that contains reports and statistics produced by the Unload and Reload tasks.

In this data set, the following reports and statistics are written in the following order:

1. Environment report that shows the EXEC parameters and the system environment. For more information, see [“Environment report”](#) on page 241.
2. Default Option Tables report for Reorganization Manager. For more information, see [“Default Option Tables report”](#) on page 241.
3. HPSIN Control Statements report for Reorganization Manager, Unload task, and Reload task  
The processing option report of IMS Index Builder is written in the IIUPRINT data set. For more information, see the *IMS Index Builder User's Guide*.
4. DB Statistics report for input database, produced when DBSTATS=YES is specified for the Unload task. The contents of this statistics report are the same as those produced for IMS HP Unload. For details of this statistics report and how to use these statistics for database tuning, see the *IMS High Performance Unload User's Guide* and read the topic that explains how to tune a database by using the DB tuning statistics.



5. Randomizing Statistics report for input HDAM database, produced when DBSTATS=YES is specified for the Unload task. The contents of this statistics report are the same as those produced for IMS HP Unload. For details of this statistics report and how to use these statistics for database tuning, see the *IMS High Performance Unload User's Guide* and read the topic that explains how to tune a database by using the DB tuning statistics.
6. Buffering and I/O Statistics report for the input database, produced by HSSR Engine used in Unload task. For more information, see [“Buffering and I/O Statistics report”](#) on page 447.
7. HALDB Process Summary report (for HALDB only)
8. Segment Count Summary report for the input database, produced by the Unload task. For more information, see [“Segment Count Summary report \(Unload task\)”](#) on page 250.
9. Segment Count Summary report for the output database, produced by the Reload task. For more information, see [“Segment Count Summary report \(Reload task\)”](#) on page 251.
10. WFP Process Summary report for PSINDEXes, produced by the Reload task. For more information, see [“WFP Process Summary report \(Reload task\)”](#) on page 253.

## Environment report

The Environment report contains EXEC parameters that were specified for the job and the release levels of the operating system and IMS.

The following figure is an example of the Environment report.

```

IMS DB REORG EXPERT                                PAGE:      1
5655-S35                                           11/01/2023 14.47.29

                                "ENVIRONMENT"

EXEC PARAMETERS

DATABASE TO REORGANIZE..... DBHD0260
SECONDARY INDEX..... DBSX0260
IMS ID..... SYS1
GLOBAL SERVICE GROUP NAME..... (SYSTEM DEFAULT)
ACTIVATE DBRC..... YES
ACTIVATE IRLM FOR NATIVE DL/I CALLS... (SYSTEM DEFAULT)
MAKE ADDRESS SPACE SWAPPABLE..... NO

SYSTEM ENVIRONMENT

OPERATING SYSTEM..... z/OS 02.04.00
STORAGE MANAGEMENT..... DFSMS/zOS 02.04.00
IMS..... IMS 15.1.0
RECON DATA SET..... IMS V15R1      (MINIMUM VERSION = 13.1)
ACCESS=SERIAL
PRODUCT VERSION..... IMS DB REORG EXPERT V4.1.0

```

Figure 59. Environment report

## Default Option Tables report

The Default Option Tables report contains contents of the System Default Option Table (HPSCOPTS) and the Installation Default Option Table (HPSCOPTI). If HPSCOPTI was used, this report contains information from both HPSCOPTS and HPSCOPTI. If HPSCOPTS was used, this report contains information only from HPSCOPTS.

For details of the Installation Default Option Table, see [Chapter 45, “Setting installation default options,”](#) on page 617.

The following figure is an example of the Default Option Tables report when HPSCOPTI was used.

"DEFAULT OPTION TABLES"

SYSTEM DEFAULT: HPSCOPTS IN RGE410.SHPSLMD0  
INSTALLATION DEFAULT: HPSCOPTI IN TEMPDS.CREORG.VRL0022.OPTLIB

KEYWORD	SYSTEM DEFAULT	INSTALLATION DEFAULT
CONDREORG	NO	YES
DECODEDBD	(NO,NO)	(NO,NO)
DECODESX	(NO,NO)	(NO,NO)
DISPOLDDS	TEMPNAME	TEMPNAME
HPIO	N/A	N/A
ILDSBLD	(YES,COND)	(YES,COND)
ITKBDATA	*NO	*NO
ITKBLOAD	*NO	*NO
ITKBSVR	*NO	*NO
KEYLABELCHK	NO	NO
PIPEWAIT	0.5,OPEN	0.5,OPEN
PIPEWAIT	15,RDWR	15,RDWR
SINDEXSUF	NO	NO
STATRL	NO	NO
ZIIPMODE	NEVER	NEVER

Figure 60. Default Option Tables report (using HPSCOPTI)

The following figure is an example of the Default Option Tables Report when HPSCOPTS was used.

"DEFAULT OPTION TABLES"

SYSTEM DEFAULT: HPSCOPTS IN RGE410.SHPSLMD0  
INSTALLATION DEFAULT: HPSCOPTI NOT FOUND

KEYWORD	SYSTEM DEFAULT
CONDREORG	NO
DECODEDBD	(NO,NO)
DECODESX	(NO,NO)
DISPOLDDS	TEMPNAME
HPIO	N/A
ILDSBLD	(YES,COND)
ITKBDATA	*NO
ITKBLOAD	*NO
ITKBSVR	*NO
KEYLABELCHK	NO
PIPEWAIT	0.5,OPEN
PIPEWAIT	15,RDWR
SINDEXSUF	NO
STATRL	NO
ZIIPMODE	NEVER

Figure 61. Default Option Tables report (using HPSCOPTS)

## HPSIN Control Statements report

The HPSIN Control Statement report contains an echo of the control statements that you specified in the HPSIN data set. You can check the options that were activated for the parallel reorganization job.

The following is an example of the HPSIN Control Statements report.

**Note:** All blank lines in the HPSIN data set are removed.

The following figure is an example of an HPSIN Control Statements report.

"HPSIN CONTROL STATEMENTS"

```
0.....1.....2.....3.....4.....5.....6.....7.....8
1234567890123456789012345678901234567890123456789012345678901234567890
(REORG)
  ITKBSRVR=FPQSVR00
  CONDREORG=YES
  DBRCAUTHCMD=YES
  DECODEDBD=YES
  IC=YES
  ICTYPE=B
  INDEXBLD=YES
  NAMESWAP=YES
  DELOLDDS=YES
  STATRL=YES
(CONDREORG)
  POLICYBY=DBTYPE
  JOURNAL=YES
(UNLOAD)
  DBSTATS=YES
(RELOAD)
  PROGMON=10000
```

Figure 62. HPSIN Control Statements report (Reorganization Manager) (Part 1 of 3)

"HPSIN CONTROL STATEMENTS"

"RUN TIME OPTIONS FOR THIS EXECUTION"

OPTIONS FOR REORG FUNCTION:

KEYWORD	VALUE
ADDBGRP	N/A (NOTE: THIS OPTION IS IGNORED WHEN ADXCFGRP=*NO)
ADXCFGRP	*NO
AUTHFAIL	ABORT
CONDREORG	YES
CRIC	N/A (NOTE: THIS OPTION IS NOT SPECIFIED)
CRUNLOAD	N/A (NOTE: THIS OPTION IS NOT SPECIFIED)
DALUNIT	SYSALLDA
DBRCAUTHCMD	YES
DBSHARE	YES
DDNMAP	(DDHD0261,TMPD0261)
DDNMAP	(DDHD0262,TMPD0262)
DDNMAP	(DDHD0263,TMPD0263)
DECODEDBD	(NO,NO)
DECODESX	(NO,NO)
DELOLDDS	YES
DISPOLDDS	DELETE (IS IN EFFECT BECAUSE DELOLDDS=YES WAS SPECIFIED)
DYNALLOC	(YES,YES,YES),Z
HPIO	N/A (NOTE: THIS OPTION IS NOT SPECIFIED FOR DRIVER)
IC	YES
ICNEEDED	N/A (NOTE: THIS OPTION IS IGNORED WHEN IC=YES)
ICTYPE	A
ILDSBLD	N/A (NOTE: THIS OPTION IS NOT APPLICABLE TO NON-HALDB)
IMSCMD	NO
IMSCMDOPT	N/A (NOTE: THIS OPTION IS IGNORED UNLESS IMSCMD=YES,TOSI)
INDEXBLD	YES,NEW
ITKBSRVR	FPQSVR00
ITKBLOAD	*NO
ITKBDATA	*NO
KEYLABELCHK	NO
LASTAUTHFLAG	OFF
NAMESWAP	YES
NAMESWAPFAIL	ABORT
NEWDBD	N/A (NOTE: THIS OPTION IS NOT SPECIFIED)
PARTITION	N/A (NOTE: THIS OPTION IS NOT APPLICABLE TO NON-HALDB)
PREFIXRES	N/A (NOTE: THIS OPTION IS NOT APPLICABLE TO THIS DATABASE)
PSINDEXBLD	N/A (NOTE: THIS OPTION IS NOT APPLICABLE TO NON-HALDB)
RC_CHANGE	NONE
REORGINPUT	DBDS
SINDEXSUF	N/A (NOTE: THIS OPTION IS IGNORED UNLESS DYNALLOC=(,NO))
SPACEALLOC	YES
STARTDB	N/A (NOTE: THIS OPTION IS IGNORED UNLESS IMSCMD=YES,TOSI)
STATRL	NO
STATUL	NO
TOSITASK	N/A (NOTE: THIS OPTION IS IGNORED UNLESS IMSCMD=YES,TOSI)
TOSITEST	N/A (NOTE: THIS OPTION IS IGNORED UNLESS IMSCMD=YES,TOSI)
TOSIWAIT	N/A (NOTE: THIS OPTION IS IGNORED UNLESS IMSCMD=YES,TOSI)
TOSIXCFGRP	N/A (NOTE: THIS OPTION IS IGNORED UNLESS IMSCMD=YES,TOSI)
ZIIPMODE	NEVER

OPTIONS FOR PIPE (ID=1) BETWEEN UNLOAD AND RELOAD:

KEYWORD	VALUE
PIPEBLKSZ	32768
PIPEDEPTH	62
PIPEWAIT	15,RDWR
PIPEWAIT	0.5,OPEN

Figure 63. HPSIN Control Statements report (Reorganization Manager) (Part 2 of 3)

"HPSIN CONTROL STATEMENTS"

"RUN TIME OPTIONS FOR THIS EXECUTION"

OPTIONS FOR PIPE (ID=2) BETWEEN RELOAD AND INDEX BUILDER:

KEYWORD	VALUE
PIPEBLKSZ	32768
PIPEDEPTH	62
PIPEWAIT	15
PIPEWAIT	0.5,OPEN

*Figure 64. HPSIN Control Statements report (Reorganization Manager) (Part 3 of 3)*

The following figure is a report example from the Unload task.

"HPSIN CONTROL STATEMENTS"

0.....1.....2.....3.....4.....5.....6.....7.....8  
1234567890123456789012345678901234567890123456789012345678901234567890  
DBSTATS=YES

"RUN TIME OPTIONS FOR THIS EXECUTION"

DBD : DBHD0260 DBORG : HDAM

OPTIONS FOR UNLOAD FUNCTION:

KEYWORD	VALUE
CHECKREC	NO
DBRECDIST	N/A (THIS OPTION IS IGNORED UNDER THE SMART REORG DRIVER)
DBRECKEYS	N/A (THIS OPTION IS IGNORED UNDER THE SMART REORG DRIVER)
DECODEDBD	N/A (THIS OPTION IS IGNORED UNDER THE SMART REORG DRIVER)
DECOMPRESS	NO
FALLBACK	N/A (THIS OPTION IS IGNORED UNDER THE SMART REORG DRIVER)
HOMECHEK	N/A (THIS OPTION IS IGNORED UNDER THE SMART REORG DRIVER)
ITKBSRVR	N/A (THIS OPTION IS IGNORED UNDER THE SMART REORG DRIVER)
ITKBLOAD	N/A (THIS OPTION IS IGNORED UNDER THE SMART REORG DRIVER)
MIGRATE	N/A (THIS OPTION IS IGNORED UNDER THE SMART REORG DRIVER)
OUTPUT	SYSUT2,*HD
PARTITION	N/A (THIS IS NOT A PARTITIONED DATABASE.)
PROGMON	0
SEGSEL	*ALL
SKIPAUTH	N/A (THIS OPTION IS IGNORED UNDER THE SMART REORG DRIVER)
STATREP	N/A (THIS OPTION IS IGNORED UNDER THE SMART REORG DRIVER)
USERHDR	N/A (*UH IS NOT SPECIFIED ON OUTPUT CONTROL STATEMENT)

OPTIONS FOR HSSR ENGINE:

KEYWORD	VALUE
BLDLPCK	NO
BUFFERS	*ALL, ,8, ,100, YES, YES
BUFSTAT	NO
BYINDEX	NO
CABBASE	1, OSAM, SEQ
CABBASE	2, OSAM, DIR
CABBASE	8, VSAM, SEQ
CABBASE	15, VSAM, DIR
COMPAUTH	NO
DATXEXIT	N/A (THIS OPTION IS IGNORED UNDER THE SMART REORG DRIVER)
DBSTATS	YES, 4
KEYCHECK	NO
LOUT	N/A (THIS OPTION IS IGNORED UNDER THE SMART REORG DRIVER)
PARTINFO	N/A (THIS OPTION IS IGNORED UNDER THE SMART REORG DRIVER)
PARTSTAT	NO
RTEXTIT	HPSURTEX
SKIPERROR	0
ZIIPMODE	NEVER

OPTIONS FOR DIAGNOSIS:

"HPSIN CONTROL STATEMENTS"

KEYWORD	VALUE
COMPAREDLI	N/A (THIS OPTION IS IGNORED UNDER THE SMART REORG DRIVER)
DIAGG	NO
RAPCHECK	NO
TRACE	(NONE)

Figure 65. HPSIN Control Statements report (Unload task)

The following figure is a report example from the Reload task.

"HPSIN CONTROL STATEMENTS"

0.....1.....2.....3.....4.....5.....6.....7.....8  
1234567890123456789012345678901234567890123456789012345678901234567890  
PROGMON=10000

"RUN TIME OPTIONS FOR THIS EXECUTION"

DBD : DBHD0260 DBORG : HDAM

OPTIONS FOR PROCESS CONTROL:

KEYWORD	VALUE	
INPUT	DFSUINPT	(FORMAT: *HD/*PHD)
DBRLBUF	45	
BUFFERNO	N/A	
DBIOBUF	15	
RECNUM	N/A	
HPIO	YES	
ZIIPMODE	NEVER	
OADSPR	NO	
GDGBASE	NO	
GDGLIMIT	N/A	
COMPRESS	NO	
COMPAUTH	NO	
FRSPC	YES	
PAD	X'00'	
SEARCH	3	
RAAFORMAT	YES	
SEQERROR	ABEND	
DATXEXIT	NO	
PROGMON	10000	
EXTENT	52	
SORT	NO	
SORTHIDAM	N/A	
CHKUPDT	N/A	
CHKTRAIL	N/A	
CHKEMPTYUL	N/A	
BMSETDSG	(*,* ,*)	
WF1REC	YES	
WF1DSN	N/A	
WF1UNIT	N/A	
WF1VOL	N/A	
WF1SPACE	N/A	
WFPHLQ	N/A	
WFPUNIT	N/A	
WFPVOL	N/A	
WFPVLCNT	N/A	
WFPSPACE	N/A	
DECODEDBD	NO	

Figure 66. HPSIN Control Statements report (Reload task) (Part 1 of 2)

"HPSIN CONTROL STATEMENTS"

0.....1.....2.....3.....4.....5.....6.....7.....8  
1234567890123456789012345678901234567890123456789012345678901234567890

ILDSBLD N/A  
ILEDATAC N/A  
ILESTORC N/A

LPART N/A  
PARTSTAT N/A  
PARTINIT N/A  
REPAIRILK N/A  
RMBSEGSZ NO

LAPIPCBNO N/A  
LAPIPCB N/A  
LAPIPDBD N/A

PIPEOWAIT N/A

OPTIONS FOR DIAGNOSIS:

KEYWORD	VALUE
DBDSNAP	NO
TWINSTAT	NO
TRACE	NO

Figure 67. HPSIN Control Statements report (Reload task) (Part 2 of 2)

In these three types of HPSIN Control Statement reports, the control statements you specified in the HPSIN data set are listed under the scale. An error message or a warning message is printed under the echo of each incorrect control statement. The "RUN TIME OPTIONS FOR THIS EXECUTION" part lists the options applied to the parallel reorganization job.

## HALDB Process Summary report

The HALDB Process Summary report contains HALDB processing information.

The following figure is an example of the HALDB Process Summary report for a PHDAM database. This example shows a case where a selection exit is used.

"HALDB PROCESS SUMMARY REPORT"

\*\*\* DBDNAME: PHD00200 \*\*\*

DATABASE ORGANIZATION.....	PHDAM
ACCESS METHOD.....	OSAM
NUMBER OF PARTITIONS DEFINED.....	5
NUMBER OF PARTITIONS UNLOADED.....	5
NUMBER OF PARTITIONS RELOADED.....	3
PARTITION SELECTION EXIT.....	DFSPSE00

\*\*\* PARTITIONS LISTED IN ORDER OF PARTITION NAME \*\*\*

U R SEQ	NAME	ID	PARTITION SELECTION STRING
* * 0001	PHD002A	1	X'1FFFFFFFFFFFFFFF'
* * 0002	PHD002B	2	X'3FFFFFFFFFFFFFFF'
* * 0003	PHD002C	3	X'5FFFFFFFFFFFFFFF'
* 0004	PHD002D	4	X'7FFFFFFFFFFFFFFF'
* 0005	PHD002E	5	X'FFFFFFFFFFFFFFF'

Figure 68. HALDB Process Summary report for a PHDAM database with selection exit (Smart Reorg utility)

### DBDNAME

The DBD name of the database



**DATABASE ORGANIZATION**

The database organization of the processed database; PHDAM or PHIDAM

**ACCESS METHOD**

The method of getting access to the database

**NUMBER OF PARTITIONS DEFINED**

The number of partitions defined in the HALDB

**NUMBER OF PARTITIONS UNLOADED**

The number of partitions unloaded by the Unload task in the HALDB

**NUMBER OF PARTITIONS RELOADED**

The number of partitions reloaded by the Reload task in the HALDB

**PARTITION SELECTION EXIT**

The name of the partition selection exit, if such an exit is used

When the high key selection is used, this field shows "N/A."

**PARTITIONS LISTED IN ORDER OF PARTITION NAME**

HALDB partitions in the order of Partition Name

**U**

The status of Unloaded partition

**\***

Processed by the Unload task

**blank**

Not processed

**R**

The status of Reloaded partition

**\***

Processed by the Reload task

**I**

Initialized by the Reload task

**blank**

Not processed

**SEQ**

The sequence number

**NAME**

The partition name defined by the IMS HALDB Partition Definition utility

**ID**

The partition ID

**PARTITION SELECTION STRING**

The value of the partition selection string

This field is not shown when the high key selection is used.

This field checks whether each partition of a database can be displayed in character, and does so if possible. Otherwise, it displays it in hexadecimal representation.

The following figure is an example of the HALDB Process Summary report for a PHDAM database. This example shows a case where a selection exit is not used.

"HALDB PROCESS SUMMARY REPORT"

\*\*\* DBDNAME: PHDV0030 \*\*\*

```

DATABASE ORGANIZATION..... PHDAM
ACCESS METHOD..... VSAM
NUMBER OF PARTITIONS DEFINED..... 5
NUMBER OF PARTITIONS UNLOADED..... 1
NUMBER OF PARTITIONS RELOADED..... 1
PARTITION SELECTION EXIT..... N/A
    
```

\*\*\* PARTITIONS LISTED IN ORDER OF PARTITION HIGH KEY \*\*\*

U R SEQ	NAME	ID	PARTITION HIGH KEY
0001	PHD003A	1	C'19999999'
0002	PHD003B	2	C'39999999'
* * 0003	PHD003C	3	C'59999999'
0004	PHD003D	4	C'79999999'
0005	PHD003E	5	C'99999999'

Figure 69. HALDB Process Summary report for a PHDAM database with no selection exit (Smart Reorg utility)

**PARTITIONS LISTED IN ORDER OF PARTITION HIGH KEY**

HALDB partitions in the order of Partition High Key

**PARTITION HIGH KEY**

The value of the high key

This field is not shown when the partition selection exit is used.

This field is shown as follows:

- In character, if TYPE=C is specified for the Root Sequence Key Field in DBDGEN, and if character representation is possible. Otherwise, in hexadecimal representation.
- In hexadecimal representation, if anything other from TYPE=C has been specified for Root Sequence Key Field in DBDGEN.

**Segment Count Summary report (Unload task)**

The Segment Count Summary report for Unload task provides the output segment occurrences of each segment type.

All values in the report are decimal, and each line describes one segment type in the database.

The following figure shows an example of the Segment Count Summary report.

"SEGMENT COUNT SUMMARY"

DBNAME = DBHD0260 DS GROUPS = 3 ORG = HDAM ACCESS METHOD = OSAM  
OUTPUT = SYSUT2

\*\*\* SEGMENT COUNT IN WHOLE DB \*\*\*

SEGNAME	LVL	DSG	PARENT	RETRIEVED	UNLOADED	DELETED BY USER EXIT
ROOTLEV1	01	01		10	10	N/A
DEP1LEV2	02	02	ROOTLEV1	11	11	N/A
DEP2LEV2	02	02	ROOTLEV1	12	12	N/A
DEP3LEV3	03	03	DEP2LEV2	9	9	N/A
DEP4LEV3	03	03	DEP2LEV2	11	11	N/A
TOTAL				53	53	N/A
TOTAL ERRORS				0		

Figure 70. Segment Count Summary report for an Unload task

This report consists of a segment count in an entire database. The following describes each item of the Segment Count Summary report. The items are common to all database organizations.

- The title is shown at the top of the page.
- The next two lines indicate the input database information and the output DD identification. The first line of the two indicates the database information found in the DBD, such as the database name, the number of data set groups, the database organization, and the access method. The second line indicates the output DD identification for this segment count summary.

**SEGNAME**

The name of the segment.

**LVL**

The hierarchical level of the segment.

**DSG**

The data set group number.

**PARENT**

The name of the parent segment.

**RETRIEVED**

The number of segment occurrences that are retrieved by the Unload task.

**UNLOADED**

The number of segment occurrences that are unloaded by the Unload task to an HD unloaded data set.

**DELETED BY USER EXIT**

The number of segment occurrences that are deleted due to a return code from a user exit routine.

If PARTSTAT=YES is specified for a HALDB, the Segment Count Summary reports per partition are also produced.

## Segment Count Summary report (Reload task)

The Segment Count Summary report for Reload task provides the balance between input and output segment occurrences of each segment type.

All values in the report are decimal, and each line describes one segment type in the database.

The following figure shows an example of the Segment Count Summary report for an HDAM database.

"SEGMENT COUNT SUMMARY"

DBNAME = DBHD0260 DS GROUPS = 3 ORG = HDAM ACCESS METHOD = OSAM

\*\*\* SEGMENT COUNT IN WHOLE DB \*\*\*

SEGNAME	LVL	DSG	PARENT	READ	RELOADED	DELETED BY RANDOMIZER	DELETED BY USER EXIT
ROOTLEV1	01	01		10	10	0	N/A
DEP1LEV2	02	02	ROOTLEV1	11	11	0	N/A
DEP2LEV2	02	02	ROOTLEV1	12	12	0	N/A
DEP3LEV3	03	03	DEP2LEV2	9	9	0	N/A
DEP4LEV3	03	03	DEP2LEV2	11	11	0	N/A
TOTAL				53	53	0	N/A

\*\*\* SEGMENT COUNT IN HDAM OVERFLOW AREA \*\*\*

SEGNAME	OCCURRENCES	PERCENTAGE
ROOTLEV1	0	0.0
DEP1LEV2	0	0.0
DEP2LEV2	0	0.0
DEP3LEV3	0	0.0
DEP4LEV3	0	0.0
TOTAL	0	

Figure 71. Segment Count Summary report for an HDAM database (Reload task)

This report consists of two parts: a segment count in the entire database, and a segment count in the HDAM, PHDAM, or HISAM overflow area. The following describes each item of the Segment Count Summary report. The items are common to all HDAM, HIDAM, HISAM, and SHISAM databases, except for the overflow area statistics items that are available for HDAM, PHDAM, and HISAM.

**SEGNAME**

The name of the segment.

**LVL**

The hierarchical level of the segment.

**DSG**

The data set group number.

**PARENT**

The name of the parent segment.

**READ**

The number of segment occurrences that are read by the Reload task for this database.

**RELOADED**

The number of segment occurrences that are reloaded by the Reload task for this database.

**DELETED BY RANDOMIZER**

The number of segment occurrences that are deleted due to a return code 4 from the HDAM or PHDAM randomizer.

**DELETED BY USER EXIT**

The number of deleted segment occurrences due to a return code 8 or 12 from the user exit routine.

The segment count in the HDAM, PHDAM, or HISAM overflow area contains the following items:

**OCCURRENCES**

The number of occurrences of the segment.

**PERCENTAGE**

The percentage of the occurrences in the overflow with respect to all occurrences of this segment type.

The following figure shows an example of the report for a HIDAM database. The segment count in the overflow area is not included in this report.

IMS HIGH PERFORMANCE LOAD		PAGE: 1				
5655-M26		02/01/2023 20.24.15				
"SEGMENT COUNT SUMMARY"						
DBNAME = DBHDV10	DS GROUPS = 1	ORG = HDAM	ACCESS METHOD = ESDS			
*** SEGMENT COUNT IN WHOLE DB ***						
SEGNAME	LVL	DSG PARENT	READ	RELOADED	DELETED BY RANDOMIZER	DELETED BY USER EXIT
ROOTLEV1	01	01		20	20	0 N/A
DEP1LEV2	02	01	ROOTLEV1	10	10	0 N/A
DEP2LEV2	02	01	ROOTLEV1	10	10	0 N/A
TOTAL				40	40	0 N/A

Figure 72. Segment Count Summary report for a HIDAM database (Reload task)

The following figure shows an example of the report if you specify the SEQERROR control statement for bypassing key sequence errors.

*** SEGMENT COUNT IN KEY SEQUENCE ERROR ***					
SEGNAME	KEY SEQUENCE ERROR		OUTPUT IN SEQERROR DS		
	OCCURRENCES	PERCENTAGE	OCCURRENCES	PERCENTAGE	
ROOTLEV1	1	20.0	1	20.0	
DEP1LEV2	1	20.0	2	20.0	
DEP2LEV2	0	0.0	3	20.0	
TOTAL	2	6.7	6	20.0	

Figure 73. Segment Count Summary report if SEQERROR is specified (Reload task)

**SEGNAME**

The name of the segment.

**KEY SEQUENCE ERROR OCCURRENCES**

The number of occurrences of key sequence errors for this segment type.

**KEY SEQUENCE ERROR PERCENTAGE**

The percentage of the occurrences of key sequence errors within all occurrences of this segment type.

**OUTPUT IN SEQERROR DS OCCURRENCES**

The number of segment occurrences saved in the SEQERROR data set for this segment type.

**OUTPUT IN SEQERROR DS PERCENTAGE**

The percentage of segment occurrences saved in the SEQERROR data set within all occurrences of this segment type.

**WFP Process Summary report (Reload task)**

The WFP Process Summary report for the Reload task summarizes information about the WFP data sets that are created for rebuilding PSINDEXes.

The following figure shows the report that is produced when PSINDEXBLD=YES is specified in the (REORG) block or the WFPHLQ control statement is specified in the (RELOAD) block.

"WFP PROCESS SUMMARY"

WFP DATA SETS INFORMATION

P	PARTITION	DDNAME	DSNAME
L	PHDV20A	HPSRP001	IMSTOOLS.WORK.HMPORDP1.PHDV020A.WFP
I	PHDV20B	HPSRP002	IMSTOOLS.WORK.HMPORDP1.PHDV020B.WFP
L	PHDV20C	HPSRP003	IMSTOOLS.WORK.HMPORDP1.PHDV020C.WFP

INDEX ENTRIES SUMMARY

PARTITION	PSINDEX	INDEX ENTRIES
PHDV20A	PSIDX01	420,142,550
	PSIDX02	1,892,333
PHDV20C	PSIDX01	15,293,320
	PSIDX02	0

Figure 74. WFP Process Summary report

**P**

The status of the WFP data sets.

**I**

Initialized and is empty.

**L**

Loaded.

**PARTITION**

The HALDB partition name of the database.

**DDNAME**

The DD name of the WFP data set.

N/A is shown if PSINDEXBLD=YES is specified in the (REORG) block and WFP data set is not used. In this case, IPRPIPE is used instead of the WFP data set.

**DSNAME**

The name of the WFP data set.

N/A is shown if PSINDEXBLD=YES is specified in the (REORG) block and WFP data set is not used. In this case, IPRPIPE is used instead of the WFP data set.

**PSINDEX**

The name of the partitioned secondary index database.

**INDEX ENTRIES**

The number of index pointer segment entries.

## HPSOUT2 data set

The HPSOUT2 data set is the secondary statistics output data set that contains the reports and statistics produced by Reorganization Manager.

The following reports produced by Reorganization Manager are written to this data set, in the following order:

1. Decoded DBD report
2. Decoded New DBD report
3. DBRC Authorization Processing for Reorganization report
4. Result of Shadow Space Allocation report, if SPACEALLOC=YES is specified

5. Result of PSINDEX Copy report if PSINDEXBLD=YES,NEW,UPDATE is specified

6. Data Set Information report

If automatic post-reorganization processing is attempted, the following reports are also produced:

- DBRC Authorization Processing for Name Swapping report
- Result of Name Swapping report (If any error occurs during the name swapping, the automated backout processing is not attempted.)
- IDCAMS Command Stream for Recovery from Name Swap Error report if a name swapping error occurs.
- DBRC Notification Processing report
- Result of Renaming Old Data Sets report

If manual post-reorganization processing is required, the following reports are also produced:

- IDCAMS Command Stream for Name Swapping report
- DBRC Notification Command Stream report

If you are attempting to delete old original data sets by DELOLDDS=YES, the Result of Old Data Sets Deletion report is produced.

If one or more errors are detected in the reorganization processing and Smart Reorg utility attempts to restore the authorization flags in RECON, the DBRC Processing for Restoring Authorization Flags report is produced.

## Decoded DBD report

The Decoded DBD report contains the resulting DBD sources statements when the DECODEDBD and DECODESXD control statements request that the original DBDs be decoded.

The results are printed in the following order, depending on the parameter specified in the control statements and the database organization of the specified DBD:

- Original primary database
- Original primary index
- Original secondary index

The following figure is an example of the Decoded DBD report.

```

*****
*
*              DBHD0210
*
*          DECODED BY IMS LMU REVERSAL
*****
*          DSNAME=TESTDS.OSFC7606.DBDLIB
*          VOL=DBT005
*          DBDGEN DATE 09/05/2023 TIME 17.31
*          DBD      NAME=DBHD0210,ACCESS=(HDAM,VSAM),           C
*                   RMNAME=(DFSHDC40,5,1000,200),PASSWD=NO,   C
*                   VERSION=          DATE 09/05/23 TIME 17.31
*****
*          DATASET GROUP NUMBER 1
*****
DSG001 DATASET DD1=DDHD0210,SIZE=(2048),SCAN=3
*****
*          SEGMENT NUMBER 1
*****
*          SEGM      NAME=ROOTLEV1,PARENT=0,BYTES=20,RULES=(LLL, LAST),   C
*                   PTR=(TWINBWD,,,)
*          FIELD    NAME=(ROOTNO,SEQ,U),START=1,BYTES=8,TYPE=C
*          FIELD    NAME=(ROOTNAME),START=9,BYTES=12,TYPE=C
*          LCHILD   NAME=(ROOTKEY,DBSX0210),PTR=INDX,RULES=LAST
*          XDFLD    NAME=XROOTNO,SEGMENT=,SRCH=(ROOTNO)
*****
*          SEGMENT NUMBER 2
*****
*          SEGM      NAME=DEP1LEV2,PARENT=((ROOTLEV1,)),BYTES=21,           C
*                   RULES=(LLL, LAST),PTR=(TWINBWD,,,)
*          FIELD    NAME=(DEP1NO,SEQ,U),START=1,BYTES=8,TYPE=C
*          FIELD    NAME=(DEP1NAME),START=9,BYTES=13,TYPE=C
*          DBDGEN
*          FINISH
*          END

```

Figure 75. Decoded DBD report for the Smart Reorg utility

## Decoded New DBD report

The Decoded New DBD report contains the resulting DBD source statements when the DECODEDBD and DECODESXD control statements request that the new DBDs be decoded.

The results are printed in the following order, depending on the parameter specified in the control statements and the database organization of the specified DBD:

- New primary database
- New primary index
- New secondary index

The following figure is an example of the Decoded New DBD report.



```

IMS DB REORG EXPERT                                "DECODED NEW DBD"                                PAGE: 1
5655-S35                                           10/01/2023 17.31.28

*****
*                               DBHD0210                               *
*                               DECODED BY IMS LMU REVERSAL          *
*****
*      DSNAME=TESTDS.OSFC7606.NEWDBDL                               *
*      VOL=DBT005                                                  *
*      DBDGEN DATE 09/05/2023 TIME 17.31                            *
*      DBD      NAME=DBHD0210,ACCESS=(HDAM,VSAM),                   C
*              RMNAME=(DFSHDC40,5,1000,200),PASSWD=NO,             C
*              VERSION=      DATE 09/05/23 TIME 17.31
*****
*      DATASET GROUP NUMBER 1                                       *
*****
DSG001 DATASET DD1=DDHD0210,SIZE=(2048),SCAN=3
*****
*      SEGMENT NUMBER 1                                             *
*****
*      SEGM      NAME=ROOTLEV1,PARENT=0,BYTES=20,RULES=(LLL, LAST), C
*              PTR=(TWINBWD,,,)
*      FIELD    NAME=(ROOTNO,SEQ,U),START=1,BYTES=8,TYPE=C
*      FIELD    NAME=(ROOTNAME),START=9,BYTES=12,TYPE=C
*      LCHILD   NAME=(ROOTKEY,DBSX0210),PTR=INDX,RULES=LAST
*      XDFLD    NAME=XROOTNO,SEGMENT=,SRCH=(ROOTNO)
*****
*      SEGMENT NUMBER 2                                             *
*****
*      SEGM      NAME=DEP1LEV2,PARENT=((ROOTLEV1,)),BYTES=21,      C
*              RULES=(LLL, LAST),PTR=(TWINBWD,,,)
*      FIELD    NAME=(DEP1NO,SEQ,U),START=1,BYTES=8,TYPE=C
*      FIELD    NAME=(DEP1NAME),START=9,BYTES=13,TYPE=C
*      DBDGEN
*      FINISH
*      END

```

Figure 76. Decoded New DBD report for the Smart Reorg utility

## DBRC Authorization Processing for Reorganization report

The DBRC Authorization Processing for Reorganization report contains the DBRC authorization processing information.

The following figure shows the report that is produced when DBRC commands are issued by Reorganization Manager at DBRC Authorization processing for reorganization.

```

IMS DB REORG EXPERT                                "DBRC AUTHORIZATION PROCESSING FOR REORGANIZATION"  PAGE: 1
5655-S35                                           02/01/2023 13.38.41

CHANGE.DB      DBD(D6806010) READON
DSP0203I      COMMAND COMPLETED WITH CONDITION CODE 00
DSP0220I      COMMAND COMPLETION TIME 23.032 13:38:41.6

IMS DB REORG EXPERT                                "DBRC AUTHORIZATION PROCESSING FOR REORGANIZATION"  PAGE: 2
5655-S35                                           02/01/2023 13.38.41

CHANGE.DB      DBD(P6806010) READON
DSP0203I      COMMAND COMPLETED WITH CONDITION CODE 00
DSP0220I      COMMAND COMPLETION TIME 23.032 13:38:41.6

IMS DB REORG EXPERT                                "DBRC AUTHORIZATION PROCESSING FOR REORGANIZATION"  PAGE: 3
5655-S35                                           02/01/2023 13.38.41

DSP0211I      COMMAND PROCESSING COMPLETE
DSP0211I      HIGHEST CONDITION CODE = 00

```

Figure 77. DBRC Authorization Processing for Reorganization report

## Result of Shadow Space Allocation report

The Result of Shadow Space Allocation report contains the result of deleting and allocating DASD space for shadow data sets.

The following figure shows the report that is produced when SPACEALLOC=YES is specified in the (REORG) block.

```

IF MAXCC EQ 0 THEN -
DO

    DELETE (TESTDS.OIFC3338.DDHD0011.Z          )
IDC3012I ENTRY TESTDS.OIFC3338.DDHD0011.Z NOT FOUND
IDC3009I ** VSAM CATALOG RETURN CODE IS 8 - REASON CODE IS IGG0CLA3-42
IDC0551I ** ENTRY TESTDS.OIFC3338.DDHD0011.Z NOT DELETED
IDC0001I FUNCTION COMPLETED, HIGHEST CONDITION CODE WAS 8

    DELETE (TESTDS.OIFC3338.DDHD0011.T          )
IDC0550I ENTRY (D) TESTDS.OIFC3338.DDHD0011.DATA.T DELETED
IDC0550I ENTRY (C) TESTDS.OIFC3338.DDHD0011.T DELETED
IDC0001I FUNCTION COMPLETED, HIGHEST CONDITION CODE WAS 0

SET MAXCC=0

DEFINE CLUSTER ( -
    NAME(TESTDS.OIFC3338.DDHD0011.Z          ) -
    MODEL(TESTDS.OIFC3338.DDHD0011          ) -
    ) -
    DATA(NAME(TESTDS.OIFC3338.DDHD0011.DATA.Z          ) -
    )
IDC0508I DATA ALLOCATION STATUS FOR VOLUME TST001 IS 0
IDC0001I FUNCTION COMPLETED, HIGHEST CONDITION CODE WAS 0

END

IF MAXCC EQ 0 THEN -
DO

    DELETE (TESTDS.OIFC3338.DDHD0012.Z          )
IDC3012I ENTRY TESTDS.OIFC3338.DDHD0012.Z NOT FOUND
IDC3009I ** VSAM CATALOG RETURN CODE IS 8 - REASON CODE IS IGG0CLA3-42
IDC0551I ** ENTRY TESTDS.OIFC3338.DDHD0012.Z NOT DELETED
IDC0001I FUNCTION COMPLETED, HIGHEST CONDITION CODE WAS 8

    DELETE (TESTDS.OIFC3338.DDHD0012.T          )
IDC0550I ENTRY (D) TESTDS.OIFC3338.DDHD0012.DATA.T DELETED
IDC0550I ENTRY (C) TESTDS.OIFC3338.DDHD0012.T DELETED
IDC0001I FUNCTION COMPLETED, HIGHEST CONDITION CODE WAS 0

SET MAXCC=0

DEFINE CLUSTER ( -
    NAME(TESTDS.OIFC3338.DDHD0012.Z          ) -
    MODEL(TESTDS.OIFC3338.DDHD0012          ) -
    ) -
    DATA(NAME(TESTDS.OIFC3338.DDHD0012.DATA.Z          ) -
    )
IDC0508I DATA ALLOCATION STATUS FOR VOLUME TST039 IS 0

```

Figure 78. Result of Shadow Space Allocation report (Part 1 of 2)

```

IDC0508I DATA ALLOCATION STATUS FOR VOLUME TST001 IS 0
IDC0001I FUNCTION COMPLETED, HIGHEST CONDITION CODE WAS 0

END

IF MAXCC EQ 0 THEN -
DO

    DELETE (TESTDS.OIFC3338.DDHD0013.Z          )
IDC3012I ENTRY TESTDS.OIFC3338.DDHD0013.Z NOT FOUND
IDC3009I ** VSAM CATALOG RETURN CODE IS 8 - REASON CODE IS IGG0CLA3-42
IDC0551I ** ENTRY TESTDS.OIFC3338.DDHD0013.Z NOT DELETED
IDC0001I FUNCTION COMPLETED, HIGHEST CONDITION CODE WAS 8

    DELETE (TESTDS.OIFC3338.DDHD0013.T          )
IDC0550I ENTRY (D) TESTDS.OIFC3338.DDHD0013.DATA.T DELETED
IDC0550I ENTRY (C) TESTDS.OIFC3338.DDHD0013.T DELETED
IDC0001I FUNCTION COMPLETED, HIGHEST CONDITION CODE WAS 0

SET MAXCC=0

DEFINE CLUSTER ( -
    NAME (TESTDS.OIFC3338.DDHD0013.Z          ) -
    MODEL (TESTDS.OIFC3338.DDHD0013          ) -
    ) -
    DATA (NAME (TESTDS.OIFC3338.DDHD0013.DATA.Z          ) -
    )
IDC0508I DATA ALLOCATION STATUS FOR VOLUME TST001 IS 0
IDC0001I FUNCTION COMPLETED, HIGHEST CONDITION CODE WAS 0

END

IDC0002I IDCAMS PROCESSING COMPLETE. MAXIMUM CONDITION CODE WAS 0

```

Figure 79. Result of Shadow Space Allocation report (Part 2 of 2)

## Result of PSINDEX Copy report

The Result of PSINDEX Copy report contains the output from IDCAMS commands that were issued for copying the PSINDEX records from the existing data sets to the new data sets.

This report is generated if you specified PSINDEXBLD=YES,NEW,UPDATE in the (REORG) block.

```

IF MAXCC EQ 0 THEN -
DO
    REPRO -
        INFILE (PSIX01A#) -
        OUTDATASET (IMSDB.PSIX0100.A00001.Z) -
        REUSE
IDC0005I NUMBER OF RECORDS PROCESSED WAS 21430
IDC0001I FUNCTION COMPLETED, HIGHEST CONDITION CODE WAS 0

```

Figure 80. Result of PSINDEX Copy report

## Data Set Information report

The Data Set Information report contains the names of the input and output database data sets and RECON data sets that were used in the parallel reorganization job.

The following figure is an example of the Data Set Information report for a non-HALDB.

RECON DATA SETS

DD NAME	STATUS	DATA SET NAME
RECON1	COPY1	TEMPDS.IPRV3.OIFC0104.RECON1
RECON2	COPY2	TEMPDS.IPRV3.OIFC0104.RECON2
RECON3	SPARE	TEMPDS.IPRV3.OIFC0104.RECON3

DATABASE DEFINITION

DBD	DBHD1250
PRIMARY INDEX	DBPX1250
SECONDARY INDEX	DBSX1251
	DBSX1252
DB ORGANIZATION	HIDAM
ACCESS METHOD	OSAM

DATA SETS USED BY EACH TASK

DBDNAME	USAGE	ALLOC BY	DD NAME	DATA SET NAME(S)
DBHD1250	(DSG-1)			
	DBRC		DDHD1251	TEMPDS.IPRV3.OIFC0104.DBHD1250.DDHD1251
	UNLOAD IMSDALIB		DDHD1251	TEMPDS.IPRV3.OIFC0104.DBHD1250.DDHD1251
	RELOAD DYNALLOC		TMPD1251	TEMPDS.IPRV3.OIFC0104.DBHD1250.DDHD1251.Z
DBHD1250	(DSG-2)			
	DBRC		DDHD1252	TEMPDS.IPRV3.OIFC0104.DBHD1250.DDHD1252
	UNLOAD IMSDALIB		DDHD1252	TEMPDS.IPRV3.OIFC0104.DBHD1250.DDHD1252
	RELOAD DYNALLOC		TMPD1252	TEMPDS.IPRV3.OIFC0104.DBHD1250.DDHD1252.Z
DBHD1250	(DSG-3)			
	DBRC		DDHD1253	TEMPDS.IPRV3.OIFC0104.DBHD1250.DDHD1253
	UNLOAD IMSDALIB		DDHD1253	TEMPDS.IPRV3.OIFC0104.DBHD1250.DDHD1253
	RELOAD DYNALLOC		TMPD1253	TEMPDS.IPRV3.OIFC0104.DBHD1250.DDHD1253.Z
DBPX1250	(PINDEX)			
	DBRC		DDPX1250	TEMPDS.IPRV3.OIFC0104.DBPX1250.DDPX1250
	UNLOAD IMSDALIB		DDPX1250	TEMPDS.IPRV3.OIFC0104.DBPX1250.DDPX1250
			(D)	TEMPDS.IPRV3.OIFC0104.DBPX1250.DDPX1250.D
			(I)	TEMPDS.IPRV3.OIFC0104.DBPX1250.DDPX1250.I
	RELOAD DYNALLOC		TMPX1250	TEMPDS.IPRV3.OIFC0104.DBPX1250.DDPX1250.Z
			(D)	TEMPDS.IPRV3.OIFC0104.DBPX1250.DDPX1250.Z.D
			(I)	TEMPDS.IPRV3.OIFC0104.DBPX1250.DDPX1250.Z.I

DBDNAME	USAGE	ALLOC BY	DD NAME	DATA SET NAME(S)
DBSX1251	(SINDEX, BUILT TO NEW DATA SET)			
	DBRC		DDSX1251	TEMPDS.IPRV3.OIFC0104.DBSX1251
	IDXBLD DYNALLOC		DDSX1251	TEMPDS.IPRV3.OIFC0104.DBSX1251.Z
			(D)	TEMPDS.IPRV3.OIFC0104.DBSX1251.Z.DATA
			(I)	TEMPDS.IPRV3.OIFC0104.DBSX1251.Z.INDEX
DBSX1252	(SINDEX, BUILT TO NEW DATA SET)			
	DBRC		DDSX1252	TEMPDS.IPRV3.OIFC0104.DBSX1252
	IDXBLD DYNALLOC		DDSX1252	TEMPDS.IPRV3.OIFC0104.DBSX1252.Z
			(D)	TEMPDS.IPRV3.OIFC0104.DBSX1252.Z.DATA
			(I)	TEMPDS.IPRV3.OIFC0104.DBSX1252.Z.INDEX

Figure 81. Data Set Information report for a non-HALDB

The Data Set Information report provides the following information:

**RECON DATA SETS**

Shows the name and status of each RECON data set.

**DATABASE DEFINITION**

Shows the organization and access method used for the database and the primary and secondary indexes defined for the database.

**DATA SETS USED BY EACH TASK**

Shows the data sets used in each task of the parallel reorganization job.

**DBDNAME**

DBD name of the database, primary index (PINDEX), or secondary index (SINDEX).

**USAGE**

The names of the database and index data sets that are registered to DBRC or that are used by the Unload, Reload, Index Builder, or Image Copy task.

**DBRC**

This line shows the names of the database and index data sets that are registered to DBRC.

**UNLOAD, RELOAD, IDXBLD, or IC**

Each of these lines shows the names of the database and index data sets that are used by the Unload task (UNLOAD), the Reload task (RELOAD), the Index Builder task (IDXBLD), or the Image Copy task (IC).

Information for the Image Copy task (IC) is printed only when CRIC=ALWAYS is specified.

**ALLOC BY**

This column shows how the data set is allocated.

**IMSDALIB**

The data set is allocated dynamically by using a DFSMDA member that is found in a library that is specified on the IMSDALIB DD statement.

**STEPLIB**

The data set is allocated dynamically by using a DFSMDA member that is found in the STEPLIB or the JOBLIB library.

**DYNALLOC**

The data set name is created from the original data set name that is defined in the corresponding DFSMDA member and is allocated dynamically.

**JCL**

The data set is specified in the JCL stream.

**DBRC**

The data set information is retrieved from DBRC. This is applicable only to HALDB.

**DD NAME**

DD name for the data set or one of the following keywords: \*ORG-(C), \*ORG-(D), and \*ORG-(I).

If INDEXBLD=YES,NEW or PSINDEXBLD=YES,NEW is specified, the cluster name of the original secondary indexes and its component names are also printed in the Data Set Information report. The DD NAME field is filled with \*ORG-(C) for the original cluster, \*ORG-(D) for its data component, and \*ORG-(I) for its index component. Those lines are not printed if DBRC is not active and SINDEXSUF=YES is not specified for the non-HALDB secondary indexes.

**DATA SET NAME(S)**

Data set name for the data set. For a VSAM data set, both the cluster name and the component names are printed.

**Note:** If INDEXBLD=YES,NEW is specified and the original secondary index data set does not exist, the VSAM component names of the shadow index are printed as the component names of the original secondary index. This is because, in this case, only the cluster name of shadow secondary index is to be renamed to the original names by the name swap processing and the component names are not changed.

The following figure is an example of the Data Set Information report for a HALDB.

RECON DATA SETS

DD NAME	STATUS	DATA SET NAME
RECON1	COPY1	TEMPDS.IPRV3.RECON1
RECON2	COPY2	TEMPDS.IPRV3.RECON2
RECON3	SPARE	TEMPDS.IPRV3.RECON3

DATABASE DEFINITION

```

DBD..... PHIO0100
SECONDARY INDEX..... PSIX0100
DB ORGANIZATION..... PHIDAM
ACCESS METHOD..... OSAM
    
```

DATA SETS USED BY EACH TASK

\*\*\* PARTITION: PHIO01A \*\*\*

TYPE	USAGE	ALLOC BY	DD NAME	DATA SET NAME(S)
-----				
DSG-A				
	DBRC		PHIO01AA	TEMPDS.IPRV3.PHIO0100.A00001
	UNLOAD DBRC		PHIO01AA	TEMPDS.IPRV3.PHIO0100.A00001
	RELOAD DYNALLOC		PHIO01AM	TEMPDS.IPRV3.PHIO0100.A00001.Z
DSG-B				
	DBRC		PHIO01AB	TEMPDS.IPRV3.PHIO0100.B00001
	UNLOAD DBRC		PHIO01AB	TEMPDS.IPRV3.PHIO0100.B00001
	RELOAD DYNALLOC		PHIO01AN	TEMPDS.IPRV3.PHIO0100.B00001.Z
DSG-C				
	DBRC		PHIO01AC	TEMPDS.IPRV3.PHIO0100.C00001
	UNLOAD DBRC		PHIO01AC	TEMPDS.IPRV3.PHIO0100.C00001
	RELOAD DYNALLOC		PHIO01AO	TEMPDS.IPRV3.PHIO0100.C00001.Z
ILDS				
	DBRC		PHIO01AL	TEMPDS.IPRV3.PHIO0100.L00001
	UNLOAD DBRC		PHIO01AL	TEMPDS.IPRV3.PHIO0100.L00001
			(D)	TEMPDS.IPRV3.PHIO0100.L00001.DATA
			(I)	TEMPDS.IPRV3.PHIO0100.L00001.INDEX
	RELOAD DYNALLOC		PHIO01AZ	TEMPDS.IPRV3.PHIO0100.L00001.Z
			(D)	TEMPDS.IPRV3.PHIO0100.L00001.Z.DATA
			(I)	TEMPDS.IPRV3.PHIO0100.L00001.Z.INDEX

Figure 82. Data Set Information report for a HALDB

**Note:** The following two lines are printed for each online reorganization capable HALDB partition:

```

ACTIVE DBDS BEFORE REORGANIZATION.... active_side
ACTIVE DBDS AFTER REORGANIZATION.... A-J note_text
    
```

Here, *active\_side* is either A-J or M-V, and *note\_text* is "(NOTE: POST PROCESSING IS NECESSARY)," which is printed when the automated post reorganization processing was not done. For, each online reorganization capable HALDB partition, new report lines for the shadow data set names are printed in addition to the lines for data set names for unload and reload processing.

## DBRC Authorization Processing for Name Swapping report

The DBRC Authorization Processing for Name Swapping report contains the DBRC authorization processing information for name swapping.

The following figure shows the report that is produced when DBRC commands are issued by Reorganization Manager at DBRC Authorization processing for name swapping.

```

IMS DB REORG EXPERT          "DBRC AUTHORIZATION PROCESSING FOR NAME SWAPPING"          PAGE:          1
5655-S35                    02/01/2023 13.38.41

CHANGE.DB    DBD(D6806010) NOAUTH
DSP0203I    COMMAND COMPLETED WITH CONDITION CODE 00
DSP0220I    COMMAND COMPLETION TIME 23.032 13:38:47.6

IMS DB REORG EXPERT          "DBRC AUTHORIZATION PROCESSING FOR NAME SWAPPING"          PAGE:          2
5655-S35                    02/01/2023 13.38.41

CHANGE.DB    DBD(P6806010) NOAUTH
DSP0203I    COMMAND COMPLETED WITH CONDITION CODE 00
DSP0220I    COMMAND COMPLETION TIME 23.032 13:38:47.6

IMS DB REORG EXPERT          "DBRC AUTHORIZATION PROCESSING FOR NAME SWAPPING"          PAGE:          3
5655-S35                    02/01/2023 13.38.41

DSP0211I    COMMAND PROCESSING COMPLETE
DSP0211I    HIGHEST CONDITION CODE = 00

```

Figure 83. DBRC Authorization Processing for Name Swapping report

## Result of Name Swapping report

The Result of Name Swapping report contains the output from IDCAMS commands that were issued during data set name swapping.

This report is generated when you have specified NAMESWAP=YES.

If any error occurs during the name swapping, the output from the IDCAMS commands issued for the follow-up processing, depending on [“NAMESWAPFAIL control statement”](#) on page 148, is shown in the following pages of this report.

```

IMS DB REORG EXPERT          "RESULT OF NAME SWAPPING"          PAGE:          1
5655-S35                    02/01/2023 13.03.15

IF MAXCC EQ 0 THEN -
DO
  ALTER  TEMPDS.IPRV3.OIFC0101.DDHD0041          -
  NEWNAME(TEMPDS.IPRV3.OIFC0101.DDHD0041.T      )
IDC0531I ENTRY TEMPDS.IPRV3.OIFC0101.DDHD0041 ALTERED
IDC0001I FUNCTION COMPLETED, HIGHEST CONDITION CODE WAS 0

END

IF MAXCC EQ 0 THEN -
DO
  ALTER  TEMPDS.IPRV3.OIFC0101.DDHD0042          -
  NEWNAME(TEMPDS.IPRV3.OIFC0101.DDHD0042.T      )
IDC0531I ENTRY TEMPDS.IPRV3.OIFC0101.DDHD0042 ALTERED
IDC0001I FUNCTION COMPLETED, HIGHEST CONDITION CODE WAS 0

END

IF MAXCC EQ 0 THEN -
DO
  ALTER  TEMPDS.IPRV3.OIFC0101.DDHD0041.Z        -
  NEWNAME(TEMPDS.IPRV3.OIFC0101.DDHD0041        )
IDC0531I ENTRY TEMPDS.IPRV3.OIFC0101.DDHD0041.Z ALTERED
IDC0001I FUNCTION COMPLETED, HIGHEST CONDITION CODE WAS 0

END

IF MAXCC EQ 0 THEN -
DO
  ALTER  TEMPDS.IPRV3.OIFC0101.DDHD0042.Z        -
  NEWNAME(TEMPDS.IPRV3.OIFC0101.DDHD0042.Z      )
IDC0531I ENTRY TEMPDS.IPRV3.OIFC0101.DDHD0042.Z ALTERED
IDC0001I FUNCTION COMPLETED, HIGHEST CONDITION CODE WAS 0

END

```

Figure 84. Result of Name Swapping report

## IDCAMS Command Stream for Name Swapping report

The IDCAMS Command Stream for Name Swapping report contains the IDCAMS commands that should be used in the manual data set name swapping.

This report is generated when you have specified NAMESWAP=NO. For the details of manual data set name swapping, see [“Performing manual name swapping”](#) on page 212.

The following figure is an example of an IDCAMS Command Stream for Name Swapping report for a non-HALDB.

```
IMS DB REORG EXPERT                                "IDCAMS COMMAND STREAM FOR NAME SWAPPING"                                PAGE: 1
5655-S35                                           02/01/2023 19.05.04

IF MAXCC EQ 0 THEN -
DO
  ALTER  TEMPDS.IPRV3.0IFC0101.DBHD1330.DDHD1331 -
  NEWNAME (TEMPDS.IPRV3.0IFC0101.DBHD1330.DDHD1331.T )
  ALTER  TEMPDS.IPRV3.0IFC0101.DBHD1330.DDHD1331.D -
  NEWNAME (TEMPDS.IPRV3.0IFC0101.DBHD1330.DDHD1331.D.T )
END
IF MAXCC EQ 0 THEN -
DO
  ALTER  TEMPDS.IPRV3.0IFC0101.DBHD1330.DDHD1332 -
  NEWNAME (TEMPDS.IPRV3.0IFC0101.DBHD1330.DDHD1332.T )
  ALTER  TEMPDS.IPRV3.0IFC0101.DBHD1330.DDHD1332.D -
  NEWNAME (TEMPDS.IPRV3.0IFC0101.DBHD1330.DDHD1332.D.T )
END
IF MAXCC EQ 0 THEN -
DO
  ALTER  TEMPDS.IPRV3.0IFC0101.DBHD1330.DDHD1331.Z -
  NEWNAME (TEMPDS.IPRV3.0IFC0101.DBHD1330.DDHD1331 )
  ALTER  TEMPDS.IPRV3.0IFC0101.DBHD1330.DDHD1331.Z.D -
  NEWNAME (TEMPDS.IPRV3.0IFC0101.DBHD1330.DDHD1331.D )
END
IF MAXCC EQ 0 THEN -
DO
  ALTER  TEMPDS.IPRV3.0IFC0101.DBHD1330.DDHD1332.Z -
  NEWNAME (TEMPDS.IPRV3.0IFC0101.DBHD1330.DDHD1332 )
  ALTER  TEMPDS.IPRV3.0IFC0101.DBHD1330.DDHD1332.Z.D -
  NEWNAME (TEMPDS.IPRV3.0IFC0101.DBHD1330.DDHD1332.D )
END
```

Figure 85. IDCAMS Command Stream for Name Swapping report for a non-HALDB

The following figure is an example of an IDCAMS Command Stream for Name Swapping report for a HALDB.



```

/* PARTITION=PHIV01A */
IF MAXCC EQ 0 THEN -
DO
  ALTER TESTDS.OSFC5101.PHIV0100.A00001 -
  NEWNAME(TESTDS.OSFC5101.PHIV0100.A00001.T )
  ALTER TESTDS.OSFC5101.PHIV0100.A00001.DATA -
  NEWNAME(TESTDS.OSFC5101.PHIV0100.A00001.DATA.T )
END
IF MAXCC EQ 0 THEN -
DO
  ALTER TESTDS.OSFC5101.PHIV0100.L00001 -
  NEWNAME(TESTDS.OSFC5101.PHIV0100.L00001.T )
  ALTER TESTDS.OSFC5101.PHIV0100.L00001.DATA -
  NEWNAME(TESTDS.OSFC5101.PHIV0100.L00001.DATA.T )
  ALTER TESTDS.OSFC5101.PHIV0100.L00001.INDEX -
  NEWNAME(TESTDS.OSFC5101.PHIV0100.L00001.INDEX.T )
END
IF MAXCC EQ 0 THEN -
DO
  ALTER TESTDS.OSFC5101.PHIV0100.X00001 -
  NEWNAME(TESTDS.OSFC5101.PHIV0100.X00001.T )
  ALTER TESTDS.OSFC5101.PHIV0100.X00001.DATA -
  NEWNAME(TESTDS.OSFC5101.PHIV0100.X00001.DATA.T )
  ALTER TESTDS.OSFC5101.PHIV0100.X00001.INDEX -
  NEWNAME(TESTDS.OSFC5101.PHIV0100.X00001.INDEX.T )
END

/* PARTITION=PHIV01B */
IF MAXCC EQ 0 THEN -
DO
  ALTER TESTDS.OSFC5101.PHIV0100.A00002 -
  NEWNAME(TESTDS.OSFC5101.PHIV0100.A00002.T )
  ALTER TESTDS.OSFC5101.PHIV0100.A00002.DATA -
  NEWNAME(TESTDS.OSFC5101.PHIV0100.A00002.DATA.T )
END
IF MAXCC EQ 0 THEN -
DO
  ALTER TESTDS.OSFC5101.PHIV0100.L00002 -
  NEWNAME(TESTDS.OSFC5101.PHIV0100.L00002.T )
  ALTER TESTDS.OSFC5101.PHIV0100.L00002.DATA -
  NEWNAME(TESTDS.OSFC5101.PHIV0100.L00002.DATA.T )
  ALTER TESTDS.OSFC5101.PHIV0100.L00002.INDEX -
  NEWNAME(TESTDS.OSFC5101.PHIV0100.L00002.INDEX.T )
END
IF MAXCC EQ 0 THEN -
DO
  ALTER TESTDS.OSFC5101.PHIV0100.X00002 -
  NEWNAME(TESTDS.OSFC5101.PHIV0100.X00002.T )
  ALTER TESTDS.OSFC5101.PHIV0100.X00002.DATA -
  NEWNAME(TESTDS.OSFC5101.PHIV0100.X00002.DATA.T )
  ALTER TESTDS.OSFC5101.PHIV0100.X00002.INDEX -
  NEWNAME(TESTDS.OSFC5101.PHIV0100.X00002.INDEX.T )
END

```

Figure 86. IDCAMS Command Stream for Name Swapping report for a HALDB (Part 1 of 2)

```

/* PARTITION=PHIV01A */
IF MAXCC EQ 0 THEN -
DO
  ALTER TESTDS.OSFC5101.PHIV0100.A00001.Z -
  NEWNAME(TESTDS.OSFC5101.PHIV0100.A00001) )
  ALTER TESTDS.OSFC5101.PHIV0100.A00001.Z.DATA -
  NEWNAME(TESTDS.OSFC5101.PHIV0100.A00001.DATA) )
END
IF MAXCC EQ 0 THEN -
DO
  ALTER TESTDS.OSFC5101.PHIV0100.L00001.Z -
  NEWNAME(TESTDS.OSFC5101.PHIV0100.L00001) )
  ALTER TESTDS.OSFC5101.PHIV0100.L00001.Z.DATA -
  NEWNAME(TESTDS.OSFC5101.PHIV0100.L00001.DATA) )
  ALTER TESTDS.OSFC5101.PHIV0100.L00001.Z.INDEX -
  NEWNAME(TESTDS.OSFC5101.PHIV0100.L00001.INDEX) )
END
IF MAXCC EQ 0 THEN -
DO
  ALTER TESTDS.OSFC5101.PHIV0100.X00001.Z -
  NEWNAME(TESTDS.OSFC5101.PHIV0100.X00001) )
  ALTER TESTDS.OSFC5101.PHIV0100.X00001.Z.DATA -
  NEWNAME(TESTDS.OSFC5101.PHIV0100.X00001.DATA) )
  ALTER TESTDS.OSFC5101.PHIV0100.X00001.Z.INDEX -
  NEWNAME(TESTDS.OSFC5101.PHIV0100.X00001.INDEX) )
END

/* PARTITION=PHIV01B */
IF MAXCC EQ 0 THEN -
DO
  ALTER TESTDS.OSFC5101.PHIV0100.A00002.Z -
  NEWNAME(TESTDS.OSFC5101.PHIV0100.A00002) )
  ALTER TESTDS.OSFC5101.PHIV0100.A00002.Z.DATA -
  NEWNAME(TESTDS.OSFC5101.PHIV0100.A00002.DATA) )
END
IF MAXCC EQ 0 THEN -
DO
  ALTER TESTDS.OSFC5101.PHIV0100.L00002.Z -
  NEWNAME(TESTDS.OSFC5101.PHIV0100.L00002) )
  ALTER TESTDS.OSFC5101.PHIV0100.L00002.Z.DATA -
  NEWNAME(TESTDS.OSFC5101.PHIV0100.L00002.DATA) )
  ALTER TESTDS.OSFC5101.PHIV0100.L00002.Z.INDEX -
  NEWNAME(TESTDS.OSFC5101.PHIV0100.L00002.INDEX) )
END
IF MAXCC EQ 0 THEN -
DO
  ALTER TESTDS.OSFC5101.PHIV0100.X00002.Z -
  NEWNAME(TESTDS.OSFC5101.PHIV0100.X00002) )
  ALTER TESTDS.OSFC5101.PHIV0100.X00002.Z.DATA -
  NEWNAME(TESTDS.OSFC5101.PHIV0100.X00002.DATA) )
  ALTER TESTDS.OSFC5101.PHIV0100.X00002.Z.INDEX -
  NEWNAME(TESTDS.OSFC5101.PHIV0100.X00002.INDEX) )
END

```

Figure 87. IDCAMS Command Stream for Name Swapping report for a HALDB (Part 2 of 2)

## DBRC Notification Processing report

The DBRC Notification Processing report contains the DBRC notification processing information.

The following figure shows the report that is produced when DBRC commands are issued by Reorganization Manager at DBRC notification processing. In this case, IC=YES was specified, and the image copy was taken successfully.

```

IMS DB REORG EXPERT                                "DBRC NOTIFICATION PROCESSING"                                PAGE: 1
5655-S35                                           02/01/2023 13.04.53

NOTIFY.REORG DBD(DBHD0040) DDN(DDHD0041) USID(0000000001) -
RUNTIME('2023.032 13:04:41.0 +09:00')
DSP0203I COMMAND COMPLETED WITH CONDITION CODE 00
DSP0220I COMMAND COMPLETION TIME 20.032 13:04:53.1

IMS DB REORG EXPERT                                "DBRC NOTIFICATION PROCESSING"                                PAGE: 2
5655-S35                                           02/01/2023 13.04.53

DSP0211I COMMAND PROCESSING COMPLETE
DSP0211I HIGHEST CONDITION CODE = 00

IMS DB REORG EXPERT                                "DBRC NOTIFICATION PROCESSING"                                PAGE: 3
5655-S35                                           02/01/2023 13.04.53

NOTIFY.REORG DBD(DBHD0040) DDN(DDHD0041) USID(0000000001) -
RUNTIME('2023.032 13:04:41.0 +09:00')
DSP0203I COMMAND COMPLETED WITH CONDITION CODE 00
DSP0220I COMMAND COMPLETION TIME 23.032 13:04:53.1

IMS DB REORG EXPERT                                "DBRC NOTIFICATION PROCESSING"                                PAGE: 4
5655-S35                                           02/01/2023 13.04.54

DSP0211I COMMAND PROCESSING COMPLETE
DSP0211I HIGHEST CONDITION CODE = 00

IMS DB REORG EXPERT                                "DBRC NOTIFICATION PROCESSING"                                PAGE: 5
5655-S35                                           02/01/2023 13.04.55

CHANGE.DB DBD(DBHD0040) AUTH READOFF
DSP0203I COMMAND COMPLETED WITH CONDITION CODE 00
DSP0220I COMMAND COMPLETION TIME 23.032 13:04:55.0
IMS DB REORG EXPERT                                "DBRC NOTIFICATION PROCESSING"                                PAGE: 6
5655-S35                                           02/01/2023 13.04.55

DSP0211I COMMAND PROCESSING COMPLETE
DSP0211I HIGHEST CONDITION CODE = 00

```

Figure 88. DBRC Notification Processing report

## IDCAMS Command Stream for Recovery from Name Swap Error report

The IDCAMS Command Stream for Recovery from Name Swap Error report contains the IDCAMS command stream that is generated by Reorganization Manager.

If a name swapping error occurs and the automated backout processing is not performed by Reorganization Manager, an IDCAMS command stream is generated by Reorganization Manager and printed in the IDCAMS Command Stream for Recovery from Name Swap Error report and in the HPSGSWAP data sets. The HPSGSWAP data set can be used as the SYSIN data set of the succeeding IDCAMS job after correcting the cause of the name swapping error.

The following figure shows the IDCAMS command stream for recovery from Name Swap Error report.

```

/*=====*/
/* RECOVERING OLD DATA SET(S) */
/*=====*/

IF MAXCC EQ 0 THEN -
DO
ALTER TESTDS.OIFC3310.DBHD0030.DDHD0031.T -
NEWNAME(TESTDS.OIFC3310.DBHD0030.DDHD0031) )
ALTER TESTDS.OIFC3310.DBHD0030.DDHD0031.DATA.T -
NEWNAME(TESTDS.OIFC3310.DBHD0030.DDHD0031.DATA) )
END

IF MAXCC EQ 0 THEN -
DO
ALTER TESTDS.OIFC3310.DBHD0030.DDHD0032.T -
NEWNAME(TESTDS.OIFC3310.DBHD0030.DDHD0032) )
ALTER TESTDS.OIFC3310.DBHD0030.DDHD0032.DATA.T -
NEWNAME(TESTDS.OIFC3310.DBHD0030.DDHD0032.DATA) )
END

IF MAXCC EQ 0 THEN -
DO
ALTER TESTDS.OIFC3310.DBHD0030.DDHD0033.T -
NEWNAME(TESTDS.OIFC3310.DBHD0030.DDHD0033) )
ALTER TESTDS.OIFC3310.DBHD0030.DDHD0033.DATA.T -
NEWNAME(TESTDS.OIFC3310.DBHD0030.DDHD0033.DATA) )
END

IF MAXCC EQ 0 THEN -
DO
ALTER TESTDS.OIFC3310.DBPX0030.DDPX0030.T -
NEWNAME(TESTDS.OIFC3310.DBPX0030.DDPX0030) )
ALTER TESTDS.OIFC3310.DBPX0030.DDPX0030.DATA.T -
NEWNAME(TESTDS.OIFC3310.DBPX0030.DDPX0030.DATA) )
END

```

Figure 89. IDCAMS Command Stream for Recovery from Name Swap Error report

## DBRC Notification Command Stream report

The DBRC Notification Command Stream report contains the DBRC commands that are required to notify DBRC of the reorganization and image copy when DBRC is active, when NAMESWAP=NO is specified, and when reorganization ends successfully.

The NOTIFY.REORG command or commands are always printed for the database data sets and indexes that have been reorganized. If IC=YES is specified, the NOTIFY.IC commands are printed for the data sets that were image-copied, and NOTIFY.UIC commands are printed for the indexes for which the VIC=Y option was specified. If IC=NO, the NOTIFY.UIC commands are printed for the data sets to which it was requested to turn off the ICNEEDED flag.

If DBRC is not active, this report is not printed. If you need to check the timestamp of each image copy, check the one that is printed in the Image Copy Dump Process report of IMS HP Image Copy. The ICTIME parameter identifies the timestamp of each image copy.

**Note:** NOTIFY.REORG command is not printed for the PHIDAM index.

The following figure shows the DBRC Notification Command Stream report.

```

NOTIFY.REORG DBD(DBHD0040) DDN(DDHD0041) USID(0000000001) -
RUNTIME('2023.032 15:08:06.4 +09:00')

```

```

NOTIFY.IC DBD(DBHD0040) DDN(DDHD0041) USID(0000000001) -
RUNTIME('2023.032 15:08:07.4 +09:00') -
BATCH -
ICDSN(TEMPDS.OSFC7303.IPR.IC1.DBHD0040.DDHD0041) -
FILESEQ(0001) UNIT(3390) -
VOLLIST(DBT00B) -
RECDCT(0000000051)

```

```

CHANGE.DB DBD(DBHD0040) AUTH READOFF

```

Figure 90. DBRC Notification Command Stream report

## Result of Old Data Sets Deletion report

The Result of Old Data Sets Deletion report contains the result of deleting old original data sets with IDCAMS commands.

This report is produced before the reorganization process if both SPACEALLOC=NO and one of DISPOLDDS=DELETE, DIPOLDDS=NEWSHADOW, and DELOLDDS=YES are specified in the (REORG) block, or after the name swapping process if DELOLDDS=YES or DISPOLDDS=DELETE is specified in the (REORG) block.

**Note:** The original data sets are renamed with a temporary name with suffix .T by the preceding name swapping process.

```
IMS DB REORG EXPERT                                "RESULT OF OLD DATA SETS DELETION"                                PAGE: 1
5655-S35                                           02/01/2023 13.04.55

DELETE (TEMPDS.IPRV3.0IFC0101.DDHD0041.T          )
IDC0550I ENTRY (A) TEMPDS.IPRV3.0IFC0101.DDHD0041.T DELETED
IDC0001I FUNCTION COMPLETED, HIGHEST CONDITION CODE WAS 0

DELETE (TEMPDS.IPRV3.0IFC0101.DDHD0042.T          )
IDC0550I ENTRY (A) TEMPDS.IPRV3.0IFC0101.DDHD0042.T DELETED
IDC0001I FUNCTION COMPLETED, HIGHEST CONDITION CODE WAS 0

DELETE (TEMPDS.IPRV3.0IFC0101.DDHD0043.T          )
IDC0550I ENTRY (A) TEMPDS.IPRV3.0IFC0101.DDHD0043.T DELETED
IDC0001I FUNCTION COMPLETED, HIGHEST CONDITION CODE WAS 0

IDC0002I IDCAMS PROCESSING COMPLETE. MAXIMUM CONDITION CODE WAS 0
```

Figure 91. Result of Old Data Sets Deletion report

## Result of Renaming Old Data Sets report

The Result of Renaming Old Data Sets report contains the result of renaming old original data sets with IDCAMS commands.

The following figure shows the report produced when DISPOLDDS=NEWSHADOW is specified in the (REORG) block.

```
IMS DB REORG EXPERT                                "RESULT OF RENAMING OLD DATA SETS"                                PAGE: 1
5655-S35                                           05/29/2023 01.36.22

IF MAXCC EQ 0 THEN -
DO
  ALTER RSTEST.IPRV3.0IFC0101.DDHD0041.T          -
  NEWNAME(RSTEST.IPRV3.0IFC0101.DDHD0041.Z      )
IDC0531I ENTRY RSTEST.IPRV3.0IFC0101.DDHD0041.T ALTERED
IDC0001I FUNCTION COMPLETED, HIGHEST CONDITION CODE WAS 0

END

IF MAXCC EQ 0 THEN -
DO
  ALTER RSTEST.IPRV3.0IFC0101.DDHD0042.T          -
  NEWNAME(RSTEST.IPRV3.0IFC0101.DDHD0042.Z      )
IDC0531I ENTRY RSTEST.IPRV3.0IFC0101.DDHD0042.T ALTERED
IDC0001I FUNCTION COMPLETED, HIGHEST CONDITION CODE WAS 0

END

IF MAXCC EQ 0 THEN -
DO
  ALTER RSTEST.IPRV3.0IFC0101.DDHD0043.T          -
  NEWNAME(RSTEST.IPRV3.0IFC0101.DDHD0043.Z      )
IDC0531I ENTRY RSTEST.IPRV3.0IFC0101.DDHD0043.T ALTERED
IDC0001I FUNCTION COMPLETED, HIGHEST CONDITION CODE WAS 0

END

IDC0002I IDCAMS PROCESSING COMPLETE. MAXIMUM CONDITION CODE WAS 0
```

Figure 92. Result of Renaming Old Data Sets report

## DBRC processing for restoring authorization flags

The DBRC processing for restoring authorization flags report contains the DBRC processing information for restoring authorization flags.

The following figure shows the report that is produced when DBRC commands are issued by Reorganization Manager at DBRC processing for restoring authorization flags in RECON. For details of the processing, see “Automated DBRC processing for restoring authorization flags” on page 74.

```

IMS DB REORG EXPERT          "DBRC PROCESSING FOR RESTORING AUTHORIZATION FLAGS"          PAGE:          1
5655-S35                    02/01/2023  17.02.40

CHANGE.DB    DBD(ITHIDM02) AUTH READOFF
DSP0203I    COMMAND COMPLETED WITH CONDITION CODE 00
DSP0220I    COMMAND COMPLETION TIME 23.032 17:02:40.5

IMS DB REORG EXPERT          "DBRC PROCESSING FOR RESTORING AUTHORIZATION FLAGS"          PAGE:          2
5655-S35                    02/01/2023  17.02.40

CHANGE.DB    DBD(ITHIDM01) AUTH READOFF
DSP0203I    COMMAND COMPLETED WITH CONDITION CODE 00
DSP0220I    COMMAND COMPLETION TIME 23.032 17:02:40.6

IMS DB REORG EXPERT          "DBRC PROCESSING FOR RESTORING AUTHORIZATION FLAGS"          PAGE:          3
5655-S35                    02/01/2023  17.02.40

CHANGE.DB    DBD(INDEX0 ) AUTH READOFF
DSP0203I    COMMAND COMPLETED WITH CONDITION CODE 00
DSP0220I    COMMAND COMPLETION TIME 23.032 17:02:40.6

IMS DB REORG EXPERT          "DBRC PROCESSING FOR RESTORING AUTHORIZATION FLAGS"          PAGE:          4
5655-S35                    02/01/2023  17.02.40

DSP0211I    COMMAND PROCESSING COMPLETE
DSP0211I    HIGHEST CONDITION CODE = 00
  
```

Figure 93. DBRC processing for restoring authorization flags

## IMS Command Processing report

The IMS Command Processing report contains the IMS command processing information.

The following figure shows the report produced when IMSCMD=YES,TOSI is specified and one or more IMS commands are issued to the IMS online subsystems by using IMS Tools Online System Interface.

```

IMS DB REORG EXPERT          "IMS COMMAND PROCESSING"          PAGE:          1
5655-S35                    02/01/2023  01.21.13

IMS COMMAND:  /DBR DB DBNAME LOCAL NOFE0V
TOSI WAIT:    300 SEC

IMSID  DBNAME  REQ RES RC  RSN STATUS
-----
IMA1   DIMSRN01 Y  Y  00  00  DFS0488I RC=00
      XIMSRN01 Y  Y  00  00  DFS0488I RC=00
      SINDEXT1 Y  Y  00  00  DFS0488I RC=00
      SINDEXT2 Y  Y  00  00  DFS0488I RC=00
IMB1   DIMSRN01 Y  Y  00  00  DFS0488I RC=00
      XIMSRN01 Y  Y  00  00  DFS0488I RC=00
      SINDEXT1 Y  Y  00  00  DFS0488I RC=00
      SINDEXT2 Y  Y  00  00  DFS0488I RC=00
IMA2   DIMSRN01 Y  Y  00  00  DFS0488I RC=00
      XIMSRN01 Y  Y  00  00  DFS0488I RC=00
      SINDEXT1 Y  Y  00  00  DFS0488I RC=00
      SINDEXT2 Y  Y  00  00  DFS0488I RC=00
IMB2   DIMSRN01 Y  Y  00  00  DFS0488I RC=00
      XIMSRN01 Y  Y  00  00  DFS0488I RC=00
      SINDEXT1 Y  Y  00  00  DFS0488I RC=00
      SINDEXT2 Y  Y  00  00  DFS0488I RC=00
  
```

Figure 94. IMS Command Processing report

This report provides the following information:

### IMS COMMAND

The IMS command that is issued.

### TOSI WAIT

The IMS Tools Online System Interface response timed out. You can specify the time by the TOSIWAIT control statement.

### IMSID

The IMS online subsystem identification to which the IMS command is issued by using IMS Tools Online System Interface.

**DBNAME**

The database name.

**REQ**

This specifies whether the IMS command has been sent to each IMS online subsystem. N means that the IMS command is not sent because of some reason shown in the STATUS column.

**RES**

This specifies whether the response from each online IMS subsystem has been received.

**RC, RSN**

These specify that the return and reason codes are received from IMS Tools Online System Interface, not from IMS. The meaning of the codes is shown in the STATUS column.

**STATUS**

The status of each command. If the command is processed by the IMS system, the return code in the IMS DFS0488I message is shown. If an error is returned from IMS Tools Online System Interface, the meaning or the error is shown.

**REQUEST IS NOT ISSUED (GLOBAL OPTION)**

This message indicates that this IMS online subsystem did not receive the IMS command directly from IMS Tools Online System Interface. The IMS command was sent to this subsystem through another subsystem that directly received the IMS command (with the GLOBAL option) from IMS Tools Online System Interface. For subsystems that did not receive IMS commands directly from IMS Tools Online System Interface, the status messages and return codes are not shown in this field.

## HPSLIST data set

---

The HPSSLIST data set is an output data set that contains the statistics produced by HSSR Engine of IMS HP Unload.

If the HPSSLIST DD statement is coded in the JCL stream, the following statistics reports produced by the Unload task are written in this data set in the following order:

1. DB Call Statistics
2. CAB Statistics (if BUFSTAT=YES is specified)

For the details of these reports, see [Chapter 28, “IPR Unload reports,” on page 409](#).

## HPSSSTAT data set

---

The HPSSSTAT data set is an output data set that contains the reports and statistics produced by the Reload task.

The following statistics reports produced by Reload task are written in this data set in the following order:

1. Data Set Statistics for output database
2. Segment Statistics for output database
3. Pointer Count Summary for output database
4. Pointer Statistics for output database

Details of the reports are shown in the following topics.

- [“Data Set Statistics report” on page 272](#)
- [“Segment Statistics report” on page 275](#)
- [“Pointer Count Summary report” on page 277](#)
- [“Pointer Statistics report” on page 278](#)

## Data Set Statistics report

The Data Set Statistics report provides physical statistics on a database by each data set group.

The following figure shows an example of the Data Set Statistics report for an HDAM database.

```
IMS HIGH PERFORMANCE LOAD                                PAGE:      1
5655-M26                                                02/01/2023 13.31.46

                "DATA SET STATISTICS"

DBNAME = DBHDV10   DS GROUPS = 3   ORG = HDAM   ACCESS METHOD = ESDS
RMNAME = DFSHDC40 MAX INSERT = 200  NBR OF RAPS = 2  MAX RBN = 5

DS GROUP = 001 OF 003  DDNAME = DDHDV10  BLKSIZE = 4,096  LRECL = 4,089
DISTRIBUTED FREE SPACE = (000,00)  SCAN = 3
NUMBER OF TOTAL BLOCKS              = 755
NUMBER OF BITMAP BLOCKS              = 1
NUMBER OF LIMITED FREE SPACE BLOCKS  = 751
NUMBER OF FULL BLOCKS               = 1
NUMBER OF FREE BLOCKS               = 2
AVERAGE SIZE OF FREE SPACE ELEMENT  = 477.7

NUMBER OF HDAM ROOT SYNONYM CHAINS   = 1
AVERAGE NUMBER OF ROOTS / SYNONYM CHAIN = 2.0
NUMBER OF ROOTS NOT ON SYNONYM CHAINS = 3
NUMBER OF ROOTS ON SYNONYM CHAINS    = 2
NUMBER OF ROOTS OUT OF RANDOMIZED BLOCK = 0
NUMBER OF HDAM RAPS USED              = 4
NUMBER OF HDAM RAPS UNUSED            = 6
NUMBER OF HDAM OVERFLOW BLOCKS       = 750

NUMBER OF SEQUENTIAL WRITES          = 756
NUMBER OF DIRECT READS               = 1
NUMBER OF DIRECT WRITES              = 1

NUMBER OF DSPB ROUTINGS              = 0
HIGHEST LENGTH OF DATA IN DSPB     = 0
AVERAGE LENGTH OF DATA IN DSPB    = 0.0

DS GROUP = 002 OF 003  DDNAME = DDHDV11  BLKSIZE = 512  LRECL = 505
DISTRIBUTED FREE SPACE = (000,00)  SCAN = 3
NUMBER OF TOTAL BLOCKS              = 43
NUMBER OF BITMAP BLOCKS              = 1
NUMBER OF LIMITED FREE SPACE BLOCKS  = 42
NUMBER OF FULL BLOCKS               = 1
NUMBER OF FREE BLOCKS               = 0
AVERAGE SIZE OF FREE SPACE ELEMENT  = 75.0

NUMBER OF SEQUENTIAL WRITES          = 44
NUMBER OF DIRECT READS               = 1
NUMBER OF DIRECT WRITES              = 1

NUMBER OF DSPB ROUTINGS              = 0
HIGHEST LENGTH OF DATA IN DSPB     = 0
AVERAGE LENGTH OF DATA IN DSPB    = 0.0

DS GROUP = 003 OF 003  DDNAME = DDHDV12  BLKSIZE = 512  LRECL = 505
DISTRIBUTED FREE SPACE = (000,00)  SCAN = 3
```

Figure 95. Data Set Statistics report for an HDAM database (Part 1 of 2)



"DATA SET STATISTICS"

NUMBER OF TOTAL BLOCKS	=	4
NUMBER OF BITMAP BLOCKS	=	1
NUMBER OF LIMITED FREE SPACE BLOCKS	=	3
NUMBER OF FULL BLOCKS	=	1
NUMBER OF FREE BLOCKS	=	0
AVERAGE SIZE OF FREE SPACE ELEMENT	=	156.7
NUMBER OF SEQUENTIAL WRITES	=	5
NUMBER OF DIRECT READS	=	1
NUMBER OF DIRECT WRITES	=	1
NUMBER OF DSPB ROUTINGS	=	0
HIGHEST LENGTH OF DATA IN DSPB	=	0
AVERAGE LENGTH OF DATA IN DSPB	=	0.0

Figure 96. Data Set Statistics report for an HDAM database (Part 2 of 2)

The report content shows the following items for each data set group. These items are common to HDAM, HIDAM, PHDAM, PHIDAM, HISAM, and SHISAM databases, except for those specifically indicated.

- The first two lines indicate the database information found in the DBD, such as the database name, number of data set groups, organization, and access method. If the organization of a reloaded database is HISAM or SHISAM, the ddname, block size, and record length are reported in this line.

The second line provides information about the randomizing module, which is provided only for an HDAM or PHDAM database.

- RMNAME specifies the 1-to-8-character alphanumeric name of a randomizing module.
- MAX INSERT is the maximum number of bytes of a database record that can be inserted into the root addressable area.
- NUMBER OF RAPS specifies the number of root anchor points desired in each control interval or block in the root addressable area.
- MAX RBN is the maximum relative block number value.
- The first line of each data set group indicates the data set information, such as data set group number, ddname, block size, or record length.

#### DISTRIBUTED FREE SPACE

The free block frequency factor (*fbff*) and the free space percentage factor (*fspf*). The range of *fbff* includes all integer values 0 - 100 except *fbff*=1. The *fspf* specifies the minimum percentage of each control interval or block that is to be left as free space. The range of *fspf* is 0 - 99.

#### SCAN

The number of direct-access device cylinders to be scanned when searching for available storage space during segment insertion operations.

#### NUMBER OF TOTAL BLOCKS

The total number of blocks or CIs written in the data set. If this is a VSAM data set, it does not include record 0.

#### NUMBER OF BITMAP BLOCKS

The total number of bitmap blocks or CIs written in the data set.

#### NUMBER OF LIMITED FREE SPACE BLOCKS

The number of blocks or CIs that do not have a free space element (FSE) large enough to hold the largest segment in the data set group.

#### NUMBER OF FULL BLOCKS

The number of blocks or CIs that do not have enough free space for an FSE. An FSE requires a minimum of 8 bytes.

#### NUMBER OF FREE BLOCKS

The number of blocks or CIs that do not have any segments in the data set group.

**AVERAGE SIZE OF FREE SPACE ELEMENT**

The average amount of free space in those blocks that are not completely full. This average includes those blocks that are completely empty.

**NUMBER OF SEQUENTIAL WRITES**

The number of sequential write operations to the database data set.

**NUMBER OF DIRECT READS**

The number of direct read operations to the database data set.

**NUMBER OF DIRECT WRITES**

The number of direct write operations to the database data set.

The following items are included only for an HDAM or PHDAM database:

**NUMBER OF HDAM ROOT SYNONYM CHAINS**

The number of HDAM or PHDAM root anchor points (RAPs) that have more than one root segment chained off them.

**AVERAGE NUMBER OF ROOTS / SYNONYM CHAINS**

The average number of HDAM or PHDAM root segments per synonym chain.

**NUMBER OF ROOTS NOT ON SYNONYM CHAINS**

The number of HDAM or PHDAM root segments that are not on any synonym chain.

**NUMBER OF ROOTS ON SYNONYM CHAINS**

The number of HDAM root segments that are on one of the synonym chains. A relatively high number here might have an impact on performance.

**NUMBER OF ROOTS OUT OF RANDOMIZED BLOCK**

The number of root segments that were randomized to given blocks, but there was not enough space in the blocks to insert the segments. Those root segments that cannot be inserted in the root addressable area are placed in the overflow area. A relatively high number here might have an impact on performance.

**NUMBER OF HDAM RAPS USED/UNUSED**

The number of total RAPs that are used or not used. The number of RAPs used versus the number of root segments is one indication of the efficiency of the randomizing routine. Comparison of the number of root segments with the number of RAPs used and unused gives you one indication of how well your HDAM or PHDAM randomizer is working. It does not indicate how uniformly the roots are distributed.

**NUMBER OF HDAM OVERFLOW BLOCKS**

The number of blocks or CIs in the overflow area.

The following items are included only for a HISAM or a SHISAM database:

**NUMBER OF TOTAL RECORDS**

The number of total logical records.

**BLOCKING FACTOR**

The value of the blocking factor for the database data set.

The following items are included only for a HISAM that has more than one hierarchical segment level:

**NUMBER OF RECORDS WITH OVERFLOW CHAINS**

The number of roots with overflow chains.

**MAX NUMBER OF OVERFLOW CHAINS**

The maximum number of VSAM ESDS roots chained off from one VSAM KSDS root.

**MIN NUMBER OF OVERFLOW CHAINS**

The minimum nonzero number of VSAM ESDS roots chained off from one VSAM KSDS root.

**AVERAGE NUMBER OF OVERFLOW CHAINS**

Average number of VSAM ESDS roots chained off from one VSAM KSDS root (of those with chains).

**NUMBER OF RECORDS WITH NO OVERFLOW CHAINS**

Number of roots without dependent chains.

### LONGEST DB RECORD LENGTH

The largest database record (in bytes) with no VSAM ESDS dependent records.

### SHORTEST DB RECORD LENGTH

The shortest database record (in bytes) with no VSAM ESDS dependent records.

### AVERAGE DB RECORD LENGTH

Average database record length (in bytes) of roots that have no VSAM ESDS dependent records.

## Segment Statistics report

The Segment Statistics report provides various information about all the segments in a database.

All values in the report are decimal and each line describes one segment type in the database.

The following figure shows an example of the Segment Statistics report for an HDAM database.

```
IMS HIGH PERFORMANCE LOAD                                PAGE: 1
5655-M26                                                  04/05/2023 16.06.07

                        "SEGMENT STATISTICS"

PARTNAME = PHI001A      PART ID = 00001

SEGNAME  LVL DSG  LENGTH OF  NONFREE  AVERAGE  AVERAGE OCCURRENCES
          LVL DSG  PRFX  DATA  OCCURRENCES  SPACE(%)  RCD SIZE  PER PRNT  PER ROOT
-----
ROOT1LV1 01 01   30    20      2    2.2      50      1.00     1.00
DEP11LV2 02 02   22   21*     7    6.7     154     3.50     3.50
DEP21LV2 02 02   22    20     10   9.2     210     5.00     5.00
DEP31LV3 03 02   22   23V     3    2.9     68      0.30     1.50
DEP41LV2 02 03   30   50V     8   14.0    320     4.00     4.00
DEP51LV3 03 03   18  133V     9   29.7    680     1.13     4.50
DEP61LV3 03 03   22   79V    16  35.3    808     2.00     8.00
-----
TOTAL                                55      2,289

VARIABLE LENGTH SEGMENT STATISTICS

SEGNAME  LENGTH OF  OCCURRENCES (VERSUS MIN)
          MIN  MAX      LESS  EQUAL  GREATER
-----
DEP31LV3 4    40      0      0      3
DEP41LV2 50   100     8      0      0
DEP51LV3 100  200     0      6      3
DEP61LV3 70   140     0     14      2

TWIN SEGMENT STATISTICS

SEGNAME  NUMBER OF  MAX CHAIN  AVG CHAIN
          CHAINS  LENGTH    LENGTH
-----
ROOT1LV1 N/A
DEP11LV2 1          6          6.0
DEP21LV2 1          9          9.0
DEP31LV3 0          0          0.0
DEP41LV2 2          6          4.0
DEP51LV3 3          3          2.3
DEP61LV3 3          8          4.7
```

Figure 97. Segment Statistics report for an HDAM database

### SEGNAME

The name of the segment.

### LVL

The hierarchical level of the segment.

### DSG

The data set group number.

### LENGTH OF PRFX

The length of the segment prefix.

## **LENGTH OF DATA**

The length of the segment data. The letter V following the number indicates that the segment has a variable length and that this data has the average data length of those occurrences found in the database. An asterisk (\*) following the number indicates that the segment is padded with 1 byte to make it an even length in the database. IMS does not write odd-length segments in HD-type databases.

## **OCCURRENCES**

The number of segment occurrences in the database. The number on the row TOTAL indicates the total number of segments in the database.

## **NONFREE SPACE (%)**

This indicates what percentage of the total number of bytes occupied by the database segments (prefix and data) is occupied by the segments of this type. This percentage should total 100%, but it might not, because of rounding.

## **AVERAGE RCD SIZE**

This indicates the contribution to the average database record size by this segment type. This value is the product of the segment length (length of prefix and data) by the average occurrences per root segment. The total number in this column shows the average length of the whole database record. Since the value of this column is rounded off, the total value of each line might not be equal to the number shown by TOTAL.

$$\text{AVERAGE RCD SIZE} = \frac{\{(\text{LENGTH OF PRFX})+(\text{LENGTH OF DATA})\}}{\text{x AVERAGE OCCURRENCES PER ROOT}}$$

## **AVERAGE OCCURRENCES PER PRNT**

The average number of occurrences of this segment type per immediate parent. It is also the average number of twin chain occurrences.

## **AVERAGE OCCURRENCES PER ROOT**

The average number of occurrences of this segment type per root segment (LVL=01). It is also the average number of occurrences in a database record.

The variable-length segment statistics provide further information about each variable-length segment with the following items:

## **SEGNAME**

The name of the variable-length segment.

## **LENGTH OF MIN**

The minimum data length of the segment occurrences.

## **LENGTH OF MAX**

The maximum data length of the segment occurrences.

## **OCCURRENCES (VERSUS MIN) LESS**

The number of occurrences of the segments that have a length less than the minimum data length of the segment. These segments might not have the data portion separated from the segments.

## **OCCURRENCES (VERSUS MIN) EQUAL**

The number of occurrences of the segments that have a length equal to the minimum data length of the segment.

## **OCCURRENCES (VERSUS MIN) GREATER**

The number of occurrences of the segments that have a length greater than the minimum data length of the segment.

## **COMPRESSION ROUTINE**

The name of the segment edit/compression routine, if specified for the segment. This is blank if no segment edit/compression routine is specified for the segment.

## **COMPRESSION FACTOR**

The compression factor shown as a percentage. The compression factor is calculated by the following formula:

$$\text{Compression factor} = \frac{\text{Bytes after expansion} - \text{Bytes before expansion}}{\text{Bytes after expansion}}$$

where "Bytes after expansion" is the sum of segment lengths after expansion. "Bytes before expansion" is the sum of segment lengths before expansion.

"0.0" is shown if the segment has no occurrence.

"N/A" is shown if no segment edit/compression routine is specified for the segment.

The twin chain statistics section provides statistics about the twin chained segments:

**SEGNAME**

The name of the segment.

**NUMBER OF CHAINS**

The total number of twin chain occurrences for the segment type.

N/A is shown if a twin pointer is not defined for the segment.

**MAX CHAIN LENGTH**

The maximum length of twin chains.

**AVG CHAIN LENGTH**

The average length of twin chains.

## Pointer Count Summary report

The Pointer Count Summary report contains a list of all the pointers to a user-specified target, and various totals for each segment pointer type.

The following figure shows an example of the Pointer Count Summary report for an HDAM database.

IMS HIGH PERFORMANCE LOAD			PAGE: 1	
5655-M26			02/01/2023 13.31.46	
"POINTER COUNT SUMMARY"				
SOURCE SEGMENT	TARGET SEGMENT	PTR TYPE	NBR OF SOURCE ZERO PTR	SEGMENTS WITH PTR
ROOTLEV1	ROOTLEV1	PTF	4	1
	DEP1LEV2	PCF	0	5
	DEP2LEV2	PCF	0	5
	DEP4LEV2	PCF	0	5
DEP1LEV2	DEP1LEV2	PTF	5	2,995
DEP2LEV2	DEP2LEV2	PTF	5	20
	DEP3LEV3	PCF	0	25
DEP3LEV3	DEP3LEV3	PTF	25	75
DEP4LEV2	DEP4LEV2	PTF	5	0

Figure 98. Pointer Count Summary report for an HDAM database

The following describes the Pointer Count Summary report shown in [Figure 98 on page 277](#). All values in the report are decimal.

**SOURCE SEGMENT**

The segment name that has one or more pointers in its prefix.

**TARGET SEGMENT**

The segment name that is pointed to by the source segment.

**PTR TYPE**

The type of pointer used. For each pointer in a prefix, a line of information is printed. If the pointer type is HF or HB, the TARGET SEGMENT field contains an asterisk (\*).

### NBR OF SOURCE SEGMENTS ZERO PTR

The number of occurrences of the source segment for which this pointer is zero.

### NBR OF SOURCE SEGMENTS WITH PTR

The number of occurrences of the source segment for which this pointer has an RBA. If the pointer type is PCF, this number indicates the number of physical twin chains in the database for the target segment type.

**Note:** If hierarchical pointers are used, the target segment name is not printed because hierarchical pointers can point to different segment types.

The Pointer Count Summary report also provides the following information:

- If the given segment type has PTF pointers, you can obtain the number of twin chains for a given segment type by looking in the SOURCE SEGMENT field and the NBR OF SOURCE SEGMENTS ZERO PTR field for the given segment type. If the given segment type has hierarchical pointers, but its parent has a PCF pointer pointing to the given segment type, you can also obtain this number by looking in the TARGET SEGMENT, PTR TYPE, and NBR OF SOURCE SEGMENTS WITH PTR fields.
- You can obtain the average number of twin chain occurrences for a given segment type by using the number of twin chains described. After determining the number of twin chains, divide that number into the total number of source segments (ZERO PTR + WITH PTR) for the segment type.

## Pointer Statistics report

The Pointer Statistics report contains a list of all the pointers to a user-specified target, and various totals and ratios for each segment pointer type.

The following figure shows an example of the Pointer Statistics report for an HDAM database.

IMS HIGH PERFORMANCE LOAD				PAGE: 1			
5655-M26				02/01/2023 13.31.46			
"POINTER STATISTICS"							
SOURCE SEGMENT	TARGET SEGMENT	PTR TYPE	NBR OF PTRS (POINT TO)			AVERAGE BLOCKS AWAY	I/O PROB
			SAME BLOCK	DIFF BLOCK	ONE BLOCK AWAY		
ROOTLEV1	ROOTLEV1	PTF	1	0	0	0.0	.000
	DEP1LEV2	PCF	0	5	0	303.4	1.000
	DEP2LEV2	PCF					1.000
	DEP4LEV2	PCF					1.000
DEP1LEV2	DEP1LEV2	PTF	2,250	745	745	1.0	.249
DEP2LEV2	DEP2LEV2	PTF	0	20	7	1.7	1.000
	DEP3LEV3	PCF	17	8	8	1.0	.320
DEP3LEV3	DEP3LEV3	PTF	50	25	25	1.0	.333
DEP4LEV2	DEP4LEV2	PTF	0	0	0	0.0	.000

Figure 99. Pointer Statistics report

The following describes the Pointer Statistics report shown in [Figure 99 on page 278](#). All values in the report are decimal.

### SOURCE SEGMENT

The segment name that has one or more pointers in its prefix.

### TARGET SEGMENT

The segment name that is pointed to by the source segment.

### PTR TYPE

The type of pointer used. For each pointer in a prefix, a line of information is printed. If the pointer type is HF or HB, the TARGET SEGMENT field contains an asterisk (\*).

### NBR OF PTRS (POINT TO) SAME BLOCK

The number of pointers of the given type that point to segments in the same physical block or CI.

**NBR OF PTRS (POINT TO) DIFF BLOCK**

The number of pointers of the given type that point to segments in a different block or CI.

**NBR OF PTRS (POINT TO) ONE BLOCK AWAY**

A refinement of the NBR OF PTRS (POINT TO) DIFF BLOCK data. For those pointers that point to segments in different blocks, this is the number of pointers that point to the next or previous block or CI.

**AVERAGE BLOCKS AWAY**

A refinement of the NBR OF PTRS (POINT TO) DIFF BLOCK data. For those pointers that point to segments in different blocks, this is the average number of blocks away. You can manually translate this number into tracks and cylinders by knowing the number of blocks or CIs per track. This data can be used to estimate how far apart the source and target segments are. The larger this number is, the longer the seeks will be.

**I/O PROB**

The probability of doing I/O in going from the source segment to the target segment using the indicated pointer type. This is an important item in doing database performance analysis. You can use the I/O PROB information to estimate the number of I/Os needed to retrieve a given segment or sequence of segments.

**Notes:**

- If the source and target segments are in different data set groups, the columns associated with NBR OF PTRS and AVERAGE BLOCKS AWAY are left blank because the data would be meaningless.
- If hierarchical pointers are used, the target segment name is not printed because hierarchical pointers can point to different segment types.

## BBEJRNL data set

---

The BBEJRNL data set contains the CRSS journal. This journal includes the messages that are issued by the DB Analyzer and the DB Sensor components.

The CRSS journal messages show the processing information for DB Analyzer and DB Sensor, as well as the results of the evaluation phases. If a warning situation is detected or if an error occurs while the DB Analyzer or the DB Sensor component is in process or in a service call to Policy Services or sensor data service, one or more warning messages or error messages are issued as journal messages. You can use the journal messages to identify the cause of the errors.

The journal messages are printed in the BBEJRNL data set when JOURNAL=YES is specified in the (CONDREORG) block.

The following figure shows an example CRSS journal.

```

2023-11-01 16:18:334 BBE0001I DB ANALYZER SERVICE STARTED
2023-11-01 16:18:334 BBE0028I IMS TOOLS KNOWLEDGE BASE SERVER FPQSVRRG WILL BE USED
2023-11-01 16:18:334 BBE0030I THE FOLLOWING OPTIONS ARE USED FOR THE DB ANALYZER SERVICE:
2023-11-01 16:18:334 BBE0031I - PRINTPRPT=YES
2023-11-01 16:18:334 BBE0031I - STORERPRPT=YES
2023-11-01 16:18:334 BBE0031I - JOURNAL=YES
2023-11-01 16:18:334 BBE0031I - DBS_HPIO=YES
2023-11-01 16:18:334 BBE0031I - DIAGDATAFROM=DBSENSOR
2023-11-01 16:18:334 BBE0031I - SENSOR_HOME=YES
2023-11-01 16:18:334 BBE0032I THE POLICY WILL BE SELECTED BY THE FOLLOWING OPTIONS:
2023-11-01 16:18:334 BBE0031I - POLICYBY=NAME
2023-11-01 16:18:334 BBE0031I - POLICYNM=SYS.DBDTYPE.HDAM
2023-11-01 16:18:348 BBE0201I POLICY SERVICES INITIALIZED
2023-11-01 16:18:350 BBE0033I DB ANALYZER SESSION WILL BE CREATED FOR THE RESOURCE THAT HAS THE FOLLOWING ATTRIBUTES:
2023-11-01 16:18:350 BBE0034I - DATABASE..... DBHD0040
2023-11-01 16:18:350 BBE0034I - DATABASE TYPE..... HDAM
2023-11-01 16:18:350 BBE0034I - DATA SET ORGANIZATION... OSAM
2023-11-01 16:18:350 BBE0034I - DBDLIB DD NAME..... IMS
2023-11-01 16:18:350 BBE0034I - RECON1 DATA SET NAME... IMSPROD.RECON1
2023-11-01 16:18:350 BBE0010I DB ANALYZER SESSION STARTED FOR DATABASE DBHD0040
2023-11-01 16:18:358 BBE0019I SENSOR DATA COLLECTION STARTED FOR DBHD0040
2023-11-01 16:18:371 BBE0020I SENSOR DATA FOR DBHD0040 STORED. RSI=00C4A9DD82332BCA8000000001320000
2023-11-01 16:18:373 BBE0216I SENSOR DATA FOR DBHD0040 IS EVALUATED AGAINST THE POLICY
2023-11-01 16:18:373 BBE0211I REORGANIZATION NEED WAS DETECTED FOR DBHD0040
2023-11-01 16:19:012 BBE0021I PREPARATION FOR SENSOR DATA COLLECTION STARTED FOR DBHD0040
2023-11-01 16:19:013 BBE0022I PREPARATION FOR SENSOR DATA COLLECTION ENDED FOR DBHD0040
2023-11-01 16:19:127 BBE0023I STORING SENSOR DATA FOR DBHD0040
2023-11-01 16:19:133 BBE0024I SENSOR DATA FOR REORGANIZED DBHD0040 STORED. RSI=00C4A9DDA4A514FA20000000013E0000
2023-11-01 16:19:282 BBE0217I SENSOR DATA FOR REORGANIZED DBHD0040 IS EVALUATED AGAINST THE POLICY
2023-11-01 16:19:282 BBE0214I WARNING EXCEPTIONS WERE DETECTED FOR REORGANIZED DBHD0040
2023-11-01 16:19:293 BBE0300I DIAGNOSIS REPORT GENERATION STARTED FOR DBHD0040
2023-11-01 16:19:294 BBE0301I DIAGNOSIS REPORT GENERATION ENDED FOR DBHD0040
2023-11-01 16:19:295 BBE0011I DB ANALYZER SESSION ENDED FOR DATABASE DBHD0040
2023-11-01 16:19:296 BBE0202I POLICY SERVICES ENDED
2023-11-01 16:19:296 BBE0002I DB ANALYZER SERVICE ENDED
    
```

Figure 100. Sample CRSS journal

### Related reference

#### JOURNAL control statement

Specifies whether to print journal messages in the output stream.

#### BBE messages

Messages that are issued by the DB Sensor service and the DB Analyzer service begin with BBE.

## BSNJM01 data set

The BSNJM01 data set contains the Policy Services journal. This journal includes the messages that are issued by the Policy Services components.

The Policy Services journal messages show the processing information for the Policy Services component, as well as the information about the policy that was used. If a warning situation is detected or if an error occurs while the Policy Services components are in process, one or more warning messages or error messages are issued as journal messages. You can use the journal messages to identify the cause of the errors.

The journal messages are printed in the BSNJM01 data set when JOURNAL=YES is specified in the (CONDREORG) block.

For details about Policy Services journal messages, see the *IMS Tools Base Policy Services User's Guide and Reference*.

### Related reference

#### JOURNAL control statement

Specifies whether to print journal messages in the output stream.

## BBEERROR data set

The BBEERROR data set contains the Data Set Allocation Error - KEYLABEL report or the Data Set Deletion Error - KEYLABEL report that is generated by the conditional reorganization job.

- The Data Set Allocation Error - KEYLABEL report contains information about the errors that occurred while allocating work data sets to obtain key labels.



- The Data Set Deletion Error - KEYLABEL report contains information about the errors that occurred while deleting work data sets that were allocated to obtain key labels.

The following figure shows an example of the Data Set Allocation Error - KEYLABEL report.

```

IMS DB REORG EXPERT                                "Data Set Allocation Error - KEYLABEL Report"                                PAGE:      1
5655-S35                                           06/16/2024 19.59.32

DEFINE CLUSTER ( -
  NAME (RSTEST.RGE410.H25NZZZ.DDHD1252.K          ) -
  MODEL (RSTEST.RGE410.H25NZZZ.DDHD1252          ) -
  MGMTCLAS(STANDARD) DATACLAS(EFNOCMP) STORCLAS(RCKC1  ) -
  REUSE ) -
  DATA( -
  VOL(*) -
)
IGD17101I DATA SET RSTEST.RGE410.H25NZZZ.DDHD1252.K
NOT DEFINED BECAUSE DUPLICATE NAME EXISTS IN CATALOG
RETURN CODE IS 8 REASON CODE IS 38 IGG0CLEH
IGD17219I UNABLE TO CONTINUE DEFINE OF DATA SET
RSTEST.RGE410.H25NZZZ.DDHD1252.K
IDC3013I DUPLICATE DATA SET NAME
IDC3009I ** VSAM CATALOG RETURN CODE IS 8 - REASON CODE IS IGG0CLEH-38
IDC3003I FUNCTION TERMINATED. CONDITION CODE IS 12

```

Figure 101. Data Set Allocation Error - KEYLABEL report

## SEQERROR data set

The SEQERROR data set contains segment data in key sequence error.

This data set is required only if you specify SEQERROR=SAVE. Segments in key sequence error and their hierarchical dependent segments are saved in this data set.

For details, see the description of SEQERROR DD statement and SEQERROR control statement in [Chapter 32, “IPR Reload utility,”](#) on page 485.

## HPSTRACE data set

The HPSTRACE data set contains the trace information and diagnostics information for GG status codes returned to the Unload task.

The following trace reports are produced in the data set:

- HSSR Trace Output report
- HSSR Trace Output report with diagnostics

For the details of these trace reports, see [Chapter 28, “IPR Unload reports,”](#) on page 409.

## HPSSNAP data set

The HPSSNAP data set is the snap dump data set.

This data set provides one of the following data:

- If the NEWDBD control statement is specified, and the new DBD is not accepted, a snapshot of the DBDs is taken.
- A snapshot of the control blocks of HSSR Engine used by Unload task. The snapshot is produced whenever HSSR Engine detects abnormalities while the control block is being initialized. For details, see [Chapter 28, “IPR Unload reports,”](#) on page 409.
- A snapshot of the DBD that is used to load the database. The snapshot is produced if you specify the DBDSNAP=YES statement for Reload task. For details, see [“HPSSNAP data set: DBD Snap report”](#) on page 578.

## Reports produced by IMS Index Builder

---

This topic describes the reports that are produced by the IMS Index Builder task.

### IIUPRINT data set

IIUPRINT is the main output file of the IMS Index Builder task.

The IMS Index Builder task produces the following information in the data set:

- processing options you selected
- layout of the indexes to be built
- diagnostic information for indexes that could not be built

For the details of these reports, see the *IMS Index Builder User's Guide*.

### IIUSOUT data set

The output from each sort task attached or started by the IMS Index Builder task is printed in this data set. The data set should be inspected whenever sort problems are encountered. For the details of this data set, see the *IMS Index Builder User's Guide*.

## Reports produced by IMS HP Prefix Resolution

---

This topic describes the reports that are produced by the IMS HP Prefix Resolution task.

The following reports and statistics are produced by IMS HP Prefix Resolution. For details about each report, see the *IMS High Performance Prefix Resolution User's Guide*.

- FABYIN Control Statements report
- Orphan Records report
- Prefix Update Processing Summary report
- Diagnostics and Summary report
- Statistics report

## Reports produced by IMS HP Image Copy

---

This topic describes the reports that are produced by the IMS HP Image Copy task.

The following reports are produced by IMS HP Image Copy:

- ICEIN Statements report (in ICEPRINT DD)
- Database Data Set Image Copy Utility report (in DFSPRINT DD)
- Image Copy Dump Process report (in ICEPRNT DD)

For the details about each report, see the *IMS High Performance Image Copy User's Guide*.

## Reports produced by IMS HP Pointer Checker

---

This topic describes the reports that are produced by the IMS HP Pointer Checker task.

IMS HP Pointer Checker produces certain statistics reports with separator pages during HASH pointer checking. To generate each of the following reports, specify a suboption of the HDPC option:

- To generate the Bit Map Display report, specify HDPC=(YES,BITMAP).
- To generate the Free Space Map report, specify HDPC=(YES,FSEMAP).
- To generate the Maximum Free Space Distribution report, specify HDPC=(YES,MAXFSD).

For details about each report, see the *IMS High Performance Image Copy User's Guide* and *IMS High Performance Pointer Checker User's Guide*.



---

## Part 4. Reorganizing databases that have external logical relationships

The following topics explain how to use the Pre-reorganization utility and the Post-reorganization utility to reorganize databases that have external logical relationships.

**Topics:**

- [Chapter 14, “Pre-reorganization utility and Post-reorganization utility,” on page 287](#)
- [Chapter 15, “Using the Pre-reorganization utility and Post-reorganization utility,” on page 295](#)
- [Chapter 16, “Pre-reorganization utility JCL requirements,” on page 301](#)
- [Chapter 17, “Pre-reorganization utility control statements,” on page 305](#)
- [Chapter 18, “Post-reorganization utility JCL requirements,” on page 313](#)
- [Chapter 19, “Post-reorganization utility control statements,” on page 319](#)
- [Chapter 20, “JCL considerations for the Smart Reorg utility and the IPR DB Scan utility,” on page 325](#)
- [Chapter 21, “Pre-reorganization utility and Post-reorganization utility JCL examples,” on page 327](#)
- [Chapter 22, “Pre-reorganization utility and Post-reorganization utility reports,” on page 335](#)



---

# Chapter 14. Pre-reorganization utility and Post-reorganization utility

By using the Pre-reorganization utility before the Smart Reorg utility and the Post-reorganization utility after the Smart Reorg utility, you can reorganize databases that have external logical relationships.

## Topics:

- [“Pre-reorganization utility and Post-reorganization utility overview” on page 287](#)
- [“Pre-reorganization utility functions” on page 287](#)
- [“Post-reorganization utility functions” on page 289](#)
- [“Process flow for reorganizing databases that have external logical relationships” on page 291](#)
- [“Restrictions for the Pre-reorganization utility and the Post-reorganization utility” on page 293](#)

---

## Pre-reorganization utility and Post-reorganization utility overview

You can run the Pre-reorganization utility and the Post-reorganization utility to complete the pre-reorganization and post-reorganization processing steps required by the Smart Reorg utility to reorganize databases that have external logical relationships.

The Pre-reorganization utility identifies the databases that need to be reorganized by the Smart Reorg utility and scanned by the IPR DB Scan utility by analyzing the DFSURCDS data set that is generated by the IMS Database Preorganization utility (DFSURPRO).

The Post-reorganization utility performs post-reorganization processing for all the databases that were reorganized or scanned. Post-reorganization processing includes name swapping, prefix resolution, and prefix update processes. You can optionally include image copy and HASH pointer check processes.

The Pre-reorganization utility and the Post-reorganization utility use DBRC. Therefore, all the databases that will be reorganized or scanned, including secondary indexes, must be registered to DBRC. Both utilities issue each DBRC command and IMS command for all target databases at the same time.

The Pre-reorganization utility and the Post-reorganization utility support the following types of database organization:

- HDAM
- HIDAM

---

## Pre-reorganization utility functions

The Pre-reorganization utility performs the pre-reorganization processing that is required by the Smart Reorg utility to reorganize databases that have external logical relationships. The Pre-reorganization utility provides full DBRC support in pre-reorganization processing.

For information about setting up DBRC for the Pre-reorganization utility, see [“Setting up the DBRC command authorization” on page 47](#).

Subsections:

- [“Detection of to-be-processed databases in a logical group” on page 288](#)
- [“Automated DBRC authorization processing” on page 288](#)
- [“Automated IMS command processing” on page 288](#)

## Detection of to-be-processed databases in a logical group

The Pre-reorganization utility scans the DFSURCDS data set that is generated by the IMS Database Preorganization utility (DFSURPRO) and identifies which databases need to be reorganized by the Smart Reorg utility and which need to be scanned by the IPR DB Scan utility.

## Automated DBRC authorization processing

If you specify the DBRCAUTHCMD=YES control statement, the Pre-reorganization utility issues either a CHANGE.DB READON command or a CHANGE.DB NOAUTH command, depending on the specified DBSHARE control statement option. The CHANGE.DB READON command changes the READ ONLY flag of the database in the RECON data sets. The CHANGE.DB NOAUTH command changes the PROHIBIT AUTHORIZATION flag of the database in the RECON data sets. Further authorization for the database is prohibited.

These commands are issued by using the DBRC API (DSPAPI) or the IMS Batch DBRC utility (DSPURX00).

If you specify the AUTHFAIL=WTOR control statement, WTOR messages are issued when the CHANGE.DB READON or CHANGE.DB NOAUTH command must be issued manually and the Pre-reorganization utility waits for operator responses.

**Recommendation:** If the Pre-reorganization utility issues the batch DBRC command successfully but the database is being used by another IMS system, the necessary authorization condition might not be satisfied. When running a Pre-reorganization utility job while the target database is online, specify the IMSCMD=YES control statement rather than the DBRCAUTHCMD=YES control statement.

For more information about each control statement, see the following topics:

- [“AUTHFAIL control statement” on page 128](#)
- [“DBRCAUTHCMD control statement” on page 131](#)
- [“DBSHARE control statement” on page 132](#)

## Automated IMS command processing

If you specify the IMSCMD=YES control statement, the Pre-reorganization utility issues either a /DBD command or a /DBR command, depending on the specified DBSHARE control statement option. The /DBD command places the database in read-only mode for the online system. The /DBR command places the database in the STOPPED, NOT OPEN status. Further authorization for the database is prohibited. These commands are issued for all the to-be-processed databases at the same time.

These commands are issued through an E-MCS console or the IMS Tools Online System Interface for an online IMS subsystem.

To set up an E-MCS console or the IMS Tools Online System Interface for the Pre-reorganization utility, see [“Setting up for using E-MCS console for IMS command processing” on page 50](#).

If you specify the AUTHFAIL=WTOR control statement, WTO messages are issued when the /DBD or /DBR command must be issued manually and the Pre-reorganization utility waits for operator responses.

For more information about each control statement, see the following topics:

- [“AUTHFAIL control statement” on page 128](#)
- [“DBSHARE control statement” on page 132](#)
- [“IMSCMD control statement” on page 140](#)



## Post-reorganization utility functions

---

The Post-reorganization utility performs the required post-reorganization processing for databases that have external logical relationships and that have been reorganized by the Smart Reorg utility. The Post-reorganization utility provides full DBRC support in post-reorganization processing.

For information about setting up DBRC for the Post-reorganization utility, see [“Setting up the DBRC command authorization”](#) on page 47.

Subsections:

- [“Automated DBRC authorization and unauthorization processing”](#) on page 289
- [“Automated IMS command processing”](#) on page 289
- [“Automated data set name swapping”](#) on page 290
- [“Dynamic allocation of database data sets”](#) on page 290
- [“Prefix resolution and update processing”](#) on page 290
- [“Image copy processing and HASH pointer checking”](#) on page 290
- [“Automated DBRC notification processing”](#) on page 290
- [“Automated DBRC processing for restoring authorization flags”](#) on page 291

### Automated DBRC authorization and unauthorization processing

If you specify the DBRCAUTHCMD=YES control statement in the Pre-reorganization utility JCL, the Post-reorganization utility performs the following actions:

- At the beginning of post-reorganization processing, the utility issues a CHANGE.DB NOAUTH command depending on the specified DBSHARE control statement option.
- After post-reorganization processing ends successfully, the utility issues a CHANGE.DB AUTH READOFF command.
- If an error occurs, the utility issues a CHANGE.DB AUTH READOFF command before terminating the job. For details, see [“Automated DBRC processing for restoring authorization flags”](#) on page 291.

These commands are issued by using the IMS Batch DBRC utility (DSPURX00).

If you specify the AUTHFAIL=WTOR control statement in the Pre-reorganization utility JCL, WTOR messages are issued when the CHANGE.DB NOAUTH command must be issued manually and the Post-reorganization utility waits for operator responses.

**Recommendation:** If the Post-reorganization utility issues the batch DBRC command successfully but the database is being used by another IMS system, the necessary authorization condition might not be satisfied. When running a Post-reorganization utility job while the target database is online, specify the IMSCMD=YES control statement rather than the DBRCAUTHCMD=YES control statement.

For more information, see the following topics:

- [“AUTHFAIL control statement”](#) on page 128
- [“DBRCAUTHCMD control statement”](#) on page 131
- [“DBSHARE control statement”](#) on page 132

### Automated IMS command processing

If you specify the IMSCMD=YES control statement in the Pre-reorganization utility JCL, the Post-reorganization utility performs the following actions:

- Before swapping the names of the data sets, the Post-reorganization utility issues a /DBR command.
- After post-reorganization processing completes, the Post-reorganization utility issues a /STA command to the subsystems that accepted the /DBR command.

**Requirement:** To have the Post-reorganization utility issue the /STA command, specify both of the following control statements in the Pre-reorganization utility JCL: IMSCMD=YES,TOSI and STARTDB=YES.

These commands are issued through an E-MCS console or the IMS Tools Online System Interface for an online IMS subsystem.

To set up an E-MCS console or the IMS Tools Online System Interface for the Post-reorganization utility, see [“Setting up for using E-MCS console for IMS command processing” on page 50.](#)

If you specify the AUTHFAIL=WTOR control statement in the Pre-reorganization utility JCL, WTO messages are issued when the /DBR command must be issued manually and Post-reorganization utility waits for operator responses.

For more information about each control statement, see the following topics:

- [“AUTHFAIL control statement” on page 128](#)
- [“DBSHARE control statement” on page 132](#)
- [“IMSCMD control statement” on page 140](#)

## Automated data set name swapping

After DBRC authorization processing and IMS command processing complete, the data set names of the old and new data sets must be swapped so that the reorganized data sets can be made available. The Post-reorganization utility invokes IDCAMS to swap the names of the original (disorganized) database data sets with the names of the shadow (reorganized) data sets.

For more information about name swapping, see [“Considerations for database data sets” on page 322.](#)

## Dynamic allocation of database data sets

The Post-reorganization utility provides ease of use by dynamically allocating database data sets. To specify the libraries that contain the DFSMDA members for dynamic allocation, the DD statement IMSDALIB is supported. The DD statement bypasses the step that needs APF authorization of the dynamic allocation library. DBRC is supported.

## Prefix resolution and update processing

The Post-reorganization utility invokes IMS HP Prefix Resolution to update the segment prefix after the data set name swapping process.

## Image copy processing and HASH pointer checking

The Post-reorganization utility supports image copy processing and HASH pointer checking in the Post-reorganization utility job step.

You do not need to add a separate job step for post-reorganization image copy processing. Image copy processing and HASH pointer checking are called if the relevant control statements are specified in the Pre-reorganization utility JCL. The image copy function is provided by IMS HP Image Copy. The HASH pointer checking function is provided by IMS HP Pointer Checker.

Image copies are taken after prefix resolution and update processing and is the same type of image copy processing done the TYPE-B Image Copy feature of the Parallel Reorganization Service.

For more information about image copy processing and DBRC notification processing, see [“Image copy process and DBRC” on page 320.](#)

## Automated DBRC notification processing

When prefix resolution and update processing and Image Copy processing succeed, the Post-reorganization utility issues a DBRC NOTIFY.REORG command for the database to create REORG records.

If you request to build a secondary index for an HDAM or HIDAM database during parallel reorganization, a NOTIFY.REORG command is also issued against secondary indexes.

The Post-reorganization utility can also issue DBRC NOTIFY.IC or NOTIFY.UIC commands for the database and indexes. For more information, see the following topics:

- [“Image copy process and DBRC” on page 320](#)
- [“ICNEEDED control statement” on page 138](#)

## Automated DBRC processing for restoring authorization flags

When errors are detected, the Post-reorganization utility issues a CHANGE.DB command to restore the READ ONLY or PROHIBIT AUTHORIZATION flag in the RECON data sets before ending reorganization processing abnormally.

To have the Post-reorganization utility issue a CHANGE.DB command, the control statement IMSCMD=YES or DBRCAUTHCMD=YES must be specified in Pre-reorganization JCL. Also, the IMS command or the DBRC command must be issued during pre-reorganization processing by the Pre-reorganization utility. If these conditions are met and if one or more of the following events occur in post-reorganization processing, the Post-reorganization utility issues a CHANGE.DB command to restore the authorization flag:

- One or more reorganization or scan processes did not complete successfully.
- The Post-reorganization utility detects one or more errors before the start of data set name swapping.
- If the NAMESWAPFAIL=BACKOUT control statement is specified and if the Post-reorganization utility detects one or more errors during data set name swapping.

### Related concepts

Process flow for reorganizing databases that have external logical relationships

Reorganizing databases that have external logical relationships requires additional jobs that perform pre-reorganization processing and post-reorganization processing.

## Process flow for reorganizing databases that have external logical relationships

---

Reorganizing databases that have external logical relationships requires additional jobs that perform pre-reorganization processing and post-reorganization processing.

Reorganization steps include the IMS Database Prereorganization utility (DFSURPRO), the Pre-reorganization utility, the Smart Reorg utility, the IPR DB Scan utility, and the Post-reorganization utility.

The following diagram illustrates the process flow of reorganizing databases that have external logical relationships.

The databases in this diagram have the following characteristics:

- The two databases, DB01 and DB02, belong to a same *logical group*. A logical group is a group of databases that have logical relationships with their related databases and index databases.
- Database DB02 has logical relationship pointers that point to segments in database DB01.
- Database DB01 is to be reorganized so database DB02 needs to be processed to resolve its logical relationship.

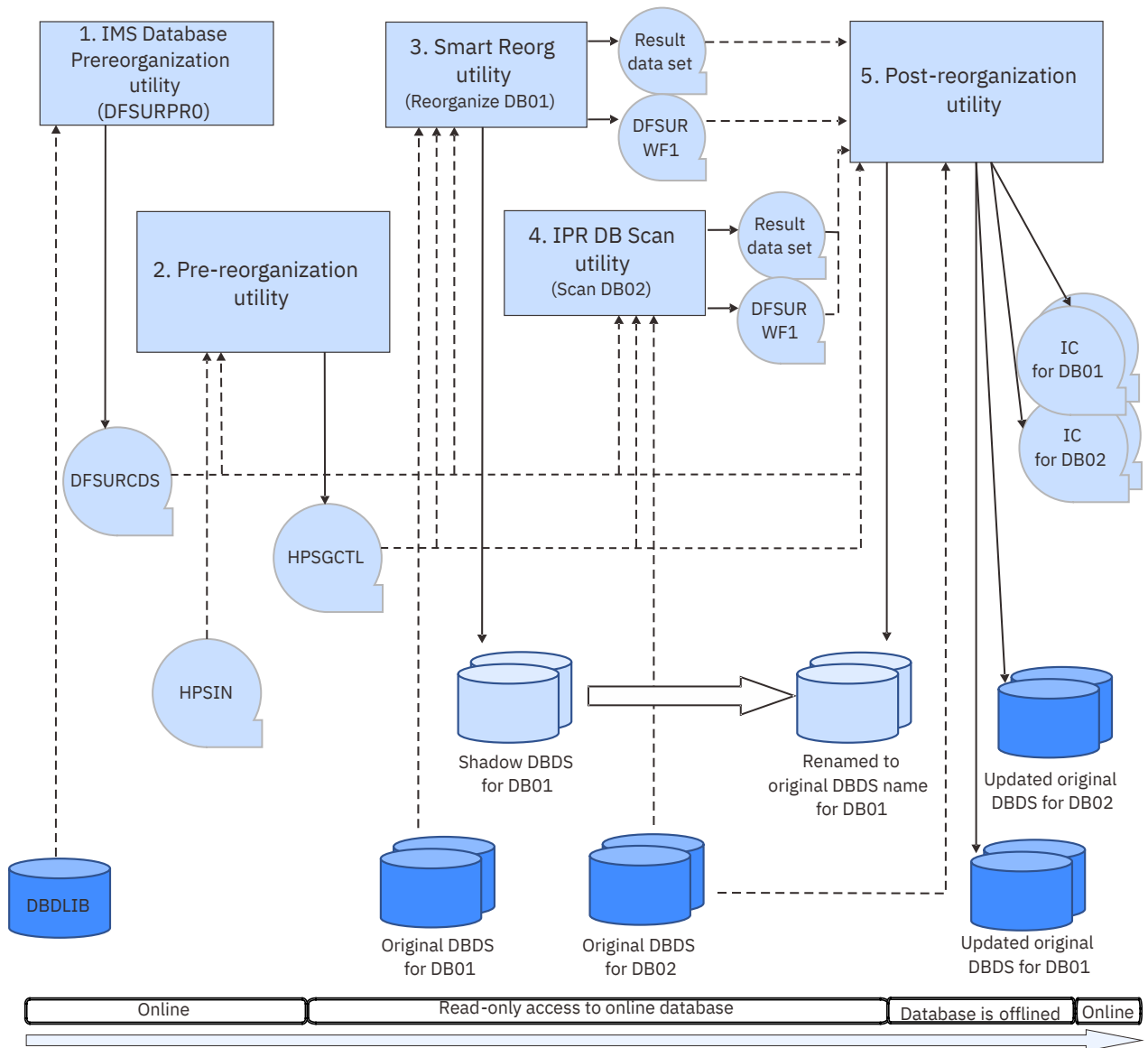

Figure 102. Process flow for reorganizing databases that have external logical relationships

The following process flow steps match the numbers in the diagram:

1. The user submits an IMS Database Prereorganization utility (DFSURPRO) job by specifying DBR=DB01 in the input control statement.

The DFSURPRO utility generates logical group information for DB01 and DB02 in the DFSURCDS data set.

2. The user submits a Pre-reorganization utility job. (The EXEC statement specifies HPSCMAIN for PGM and 'FUNC=PR' for PARM.)

- a. The Pre-reorganization utility analyzes the control statements that are specified in the HPSIN data set.

The utility also checks the consistency between the DFSURCDS data set and the DBD, and determines which databases need to be reorganized and which databases need to be scanned.

- b. The Pre-reorganization utility issues DBRC CHANGE.DB commands and IMS /DBD commands for all databases that are to be processed.

The databases that are to be processed are restricted to read-only processing.

- c. The Pre-reorganization utility writes results of control statement analysis and the condition of each to-be-processed database in the HPSGCTL data set.
3. The user submits a Smart Reorg utility job for database DB01 by specifying the HPSGCTL data set as an input.

The Smart Reorg utility creates shadow database data sets by unloading, reloading, and building indexes. The utility also writes the processing result in the result data set and information about logical relationships in the DFSURWF1 data set.

**Note:** The Smart Reorg utility does not perform name swapping.

4. The user submits an IPR DB Scan utility job for database DB02 by specifying the HPSGCTL data set as an input.

The IPR DB Scan utility scans the database to resolve logical relationships, writes the processing result in the result data set and information about logical relationships in the DFSURWF1 data set.

**Note:** You can submit the IPR DB Scan job before running the Smart Reorg utility job, or you can submit both jobs at the same time.

5. The user submits a Post-reorganization utility job by specifying the HPSGCTL data set as an input. (The EXEC statement specifies HPSCMAIN for PGM and 'FUNC=PO' for PARM.)

- a. The Post-reorganization utility reads the result data sets to determine whether post-processing can be performed.
- b. The Post-reorganization utility issues DBRC CHANGE.DB commands and IMS /DBR commands for all databases that are to be processed.

Access to these databases is prohibited.

- c. The Post-reorganization utility performs name swapping for the reorganized database.
- d. The prefix resolution task of the Post-reorganization utility invokes the IMS HP Prefix Resolution utility.

The IMS HP Prefix Resolution utility performs prefix resolution and update for the reorganized database (DB01) and the scanned database (DB02) by using the DFSURWF1 data sets.

- e. The image copy task of the Post-reorganization utility invokes the IMS HP Image Copy utility.

The IMS HP Image Copy utility creates image copies of DB01 and DB02.

- f. The Post-reorganization utility issues a DBRC NOTIFY.REORG command for the reorganized database (DB01).

- g. The Post-reorganization utility issues DBRC NOTIFY.IC commands for DB01 and DB02.

- h. The Post-reorganization utility issues DBRC CHANGE.DB AUTH READOFF commands for DB01 and DB02.

- i. If the DISPOLDDS=DELETE control statement is specified, the Post-reorganization utility deletes the original input database data sets (original DBDS for DB01).

- j. The Post-reorganization utility issues IMS /STA commands for DB01 and DB02.

The number of databases scanned by the IPR DB Scan utility varies depending on the number of logically related databases. To reorganize multiple databases that belong to the same logical group, you must submit multiple Smart Reorg utility jobs. Therefore, the number of IPR DB Scan jobs and Smart Reorg jobs varies.

## Restrictions for the Pre-reorganization utility and the Post-reorganization utility

---

Certain restrictions apply to using the Pre-reorganization utility and the Post-reorganization utility.

Before using the Pre-reorganization utility and the Post-reorganization utility, be aware of the following restrictions:

- All databases to be reorganized or scanned must be in a same logical group and each database must be registered to DBRC.
- HISAM databases are not supported. Only HDAM and HIDAM databases that have logical relationships are supported.
- Conditional Reorganization mode is not supported. The Smart Reorg utility job that is run after the Pre-reorganization utility job must be in Unconditional Reorganization mode.
- The Smart Reorg utility job that is run after the Pre-reorganization utility job must not designate a DBD change during reorganization.

---

# Chapter 15. Using the Pre-reorganization utility and Post-reorganization utility

To reorganize databases that have logical relationships, you must run the IMS Database Prereorganization utility (DFSURPRO), the Pre-reorganization utility, the Smart Reorg utility, the IPR DB Scan utility, and the Post-reorganization utility.

## Topics:

- [“Reorganizing databases that have external logical relationships” on page 295](#)
- [“Result data sets” on page 296](#)
- [“Cleaning up work data sets by using the Cleanup utility” on page 296](#)
- [“Recovering from Post-reorganization utility errors” on page 298](#)

---

## Reorganizing databases that have external logical relationships

To reorganize databases that have logical relationships, you must run the IMS Database Prereorganization utility (DFSURPRO) and the Pre-reorganization utility before running the Smart Reorg utility. After running the Smart Reorg utility, you must run the IPR DB Scan utility and the Post-reorganization utility.

## Procedure

To reorganize databases that have logical relationships, complete the following steps:

1. Determine a schedule to run a reorganization job for the target databases.
2. Create image copies of all the databases that are involved in logical relationship, including the databases to be reorganized.
3. Run the IMS Database Prereorganization utility (DFSURPRO) to create the DFSURCDS data set.
4. Code and submit Pre-reorganization utility JCL.
  - a) Code the JCL stream for the Pre-reorganization utility job.
  - b) Specify the control statements on the HPSIN DD statement.

See Chapter 17, [“Pre-reorganization utility control statements,” on page 305](#) for a list of control statements for the Pre-reorganization utility.

- c) Submit the Pre-reorganization utility job.
5. Check the results of the job by reviewing the reports.
  6. Code and submit Smart Reorg utility JCL and IPR DB Scan utility JCL.
    - a) Code the JCL stream for the Smart Reorg utility jobs and the IPR DB Scan utility jobs for the databases that were identified by the IMS Database Prereorganization utility (DFSURPRO).
    - b) Specify the control statements in the HPSIN DD statement.

Certain considerations apply when coding HPSIN control statements for Smart Reorg utility and IPR DB Scan utility jobs. For more information, see the following topics:

- [“Smart Reorg utility JCL considerations \(after running the Pre-reorganization utility\)” on page 325](#)
- [“IPR DB Scan utility JCL considerations \(after running the Pre-reorganization utility\)” on page 326](#)

- c) Submit the Smart Reorg utility and IPR DB Scan utility jobs.
7. Ensure that all Smart Reorg utility jobs and IPR DB Scan utility jobs have completed.

Check the results of the jobs by reviewing the reports that were produced by individual reorganization tasks, which include the Unload task and the Reload task.

8. Code and submit Post-reorganization utility JCL.

- a) Code the JCL stream for the Post-reorganization utility job.
  - b) Submit the Post-reorganization utility JCL stream.
9. Check the results of the job by reviewing the reports that were produced by individual post-processing tasks.

### Related reference

Pre-reorganization utility and Post-reorganization utility JCL examples

Use the following examples to code JCL for reorganizing databases that have external logical relationships by using the Pre-reorganization utility and the Post-reorganization utility.

## Result data sets

---

The result data sets are created dynamically by the Pre-reorganization utility. These data sets contain execution results of subsequent Smart Reorg utility jobs or IPR DB Scan utility jobs and information that is required for running the Post-reorganization utility.

You do not need to specify the result data sets in Pre-reorganization utility, Smart Reorg utility, IPR DB Scan utility, and Post-reorganization utility JCL because these utilities dynamically allocate the data sets.

The naming convention of the result data sets is as follows:

```
hlq.RSL.dbdname
```

### **hlq**

The high-level qualifier that was specified by the WORKHLQ control statement in Pre-reorganization utility JCL.

### **dbdname**

The name of the database to be processed.

Before running the Post-reorganization utility, all the target databases must be reorganized or scanned so that the result data sets for those databases are created.

If Smart Reorg utility or IPR DB Scan utility jobs ended abnormally, the Post-reorganization utility does not run the post-processing step. Instead, the utility restores the DBRC flags to the original state, issues error messages, and ends the job. For details, see [“Automated DBRC processing for restoring authorization flags” on page 291](#).

The result data sets are deleted automatically when the Post-reorganization utility job completes successfully. If the Post-reorganization utility job ends abnormally, delete the result data sets manually or use the Cleanup utility. For more information about the Cleanup utility, see [“Cleaning up work data sets by using the Cleanup utility” on page 296](#).

## Cleaning up work data sets by using the Cleanup utility

---

Some work data sets (including the result data sets) that are used by the Pre-reorganization utility and the Post-reorganization utility are deleted automatically when the Post-reorganization utility ends successfully. However, if you want to rerun the Pre-reorganization utility job without running the Post-reorganization utility, you can use the Cleanup utility to delete the work data sets.

### About this task

The following table shows the work data sets that are generated during the reorganization of databases that have external logical relationships and describes how to delete the data sets.

If you want to rerun the reorganization jobs, you must delete the following work data sets before rerunning the jobs:



Table 34. Work data sets that are generated during database reorganization, and how to delete them

Data set	Created and used by	How to delete
HPSGCTL	Created by the Pre-reorganization utility. Used by the following utilities: <ul style="list-style-type: none"> <li>• Smart Reorg utility</li> <li>• IPR DB Scan utility</li> <li>• Post-reorganization utility</li> </ul>	Automatically deleted when the Post-reorganization utility job is completed successfully.  If it remains, delete the data set manually or run the Cleanup utility.
Result	Allocated by the Pre-reorganization utility. Data is written by the following utilities: <ul style="list-style-type: none"> <li>• Smart Reorg utility</li> <li>• IPR DB Scan utility</li> </ul> Used by the Post-reorganization utility.	Automatically deleted when the Post-reorganization utility job is completed successfully.  If it remains, delete the data set manually or run the Cleanup utility.
DFSURCDS	Created by the IMS Database Prereorganization utility (DFSURPRO). Used by the following utilities: <ul style="list-style-type: none"> <li>• Pre-reorganization utility</li> <li>• Smart Reorg utility</li> <li>• IPR DB Scan utility</li> <li>• Post-reorganization utility</li> </ul>	This data set is not deleted automatically. Delete the data set manually.
DFSURWF1	Created by the following utilities: <ul style="list-style-type: none"> <li>• Smart Reorg utility</li> <li>• IPR DB Scan utility</li> </ul> Used by the Post-reorganization utility.	This data set is not deleted automatically. Delete the data set manually.

You can delete the HPSGCTL data set and result data sets by using the Cleanup utility.

## Procedure

To delete the data sets by using the Cleanup utility, complete the following steps:

1. Code JCL for the Cleanup utility.

The following table summarizes the JCL requirements for the Cleanup utility:

Table 35. Cleanup utility JCL requirements

Statement	Description
EXEC	This statement must be in the following form: <pre>//stepname EXEC PGM=HPSCMAIN,PARM='FUNC=CL'</pre>
STEPLIB DD	Points to the following library data sets: <ul style="list-style-type: none"> <li>• IMS Database Reorganization Expert load module library (required)</li> <li>• IMS RESLIB library (required)</li> </ul> This DD statement must be specified.

Table 35. Cleanup utility JCL requirements (continued)

Statement	Description
HPSGCTL DD	This input data set defines the control data set that contains the data that is generated by the Pre-reorganization utility. This DD statement must be specified. This data set must reside on a direct-access device. This data set is deleted when the Cleanup utility processing completes successfully.
SYSPRINT DD	This output data set contains the output from the IDCAMS commands that will be issued by the Cleanup utility. This DD statement is optional. If the DD statement is not coded, it is dynamically allocated to the SYSOUT stream.  The data set contains 133-byte, fixed-length records. It can reside on a tape, direct-access device, or printer; or it can be routed through the output stream. If BLKSIZE is coded in the DD statement, it must be a multiple of 133. The recommended specification is as follows:  <pre>//SYSPRINT DD SYSOUT=A</pre>

2. Submit the job.
3. In the SYSPRINT data set, locate the output from the IDCAMS commands that were issued by the Cleanup utility. Ensure that the data sets were deleted.

The following figure shows an example of the IDCAMS output.

```

IDCAMS  SYSTEM SERVICES                                TIME: 11:11:34          07/01/23    PAGE    1
DELETE (HPS.POSTRERG.RSL.DB31VPA0 ) NONVSAM
IDC0550I ENTRY (A) HPS.POSTRERG.RSL.DB31VPA0 DELETED
IDC0001I FUNCTION COMPLETED, HIGHEST CONDITION CODE WAS 0
DELETE (HPS.POSTRERG.RSL.DB31VPB0 ) NONVSAM
IDC0550I ENTRY (A) HPS.POSTRERG.RSL.DB31VPB0 DELETED
IDC0001I FUNCTION COMPLETED, HIGHEST CONDITION CODE WAS 0
DELETE (HPS.POSTRERG.HPSGCTL ) NONVSAM
IDC0550I ENTRY (A) HPS.POSTRERG.HPSGCTL DELETED
IDC0001I FUNCTION COMPLETED, HIGHEST CONDITION CODE WAS 0

```

Figure 103. IDCAMS command output (Cleanup utility)

## Recovering from Post-reorganization utility errors

Post-reorganization processing includes many tasks. Therefore, the actions that are required to correct the error condition depend on the error type.

### Procedure

The following table summarizes the actions of the Post-reorganization utility when an error is encountered. It also summarizes the user actions for recovering from the error conditions.

Table 36. Post-reorganization utility error types and actions

Error type	Post-reorganization utility action	User action
Errors were found in the ICEIN data set while analyzing control statements for image copy processing.	Issues error messages and stops processing. Does not restore the authorization flags.	Correct the control statements in the ICEIN data set, and rerun the Post-reorganization utility job.
One or more Smart Reorg utility jobs or IPR DB Scan utility jobs have not completed yet. (HPSG0032E)	Issues error messages and stops processing. Does not restore the authorization flags.	Wait until the Smart Reorg utility jobs or the IPR DB Scan utility jobs end and rerun the Post-reorganization utility job.

Table 36. Post-reorganization utility error types and actions (continued)

Error type	Post-reorganization utility action	User action
One or more Smart Reorg utility jobs or IPR DB Scan utility jobs did not complete successfully. (HPSG0030E)	Issues error messages and stops processing. Restores the authorization flags.	Identify the error that occurred in Smart Reorg utility or IPR DB Scan utility jobs, and correct the error.  Rerun all the jobs including Pre-reorganization utility, Smart Reorg utility, IPR DB Scan utility, and Post-reorganization utility jobs.
Errors occurred after the initialization process but before the name swapping process.  <b>Note:</b> Message HPSG0021I notifies the completion of the initialization process.	Issues error messages and stops processing. Restores the authorization flags.	Identify the error that occurred in the Post-reorganization utility job, and correct the error.  Rerun all the jobs including Pre-reorganization utility, Smart Reorg utility, IPR DB Scan utility, and Post-reorganization utility jobs.
Errors occurred while swapping data set names.	Performs the action that is specified on the NAMESWAPFAIL control statement.	Identify the error that occurred while swapping data set names, and correct the error.  Rerun all the jobs including Pre-reorganization utility, Smart Reorg utility, IPR DB Scan utility, and Post-reorganization utility jobs.
Errors occurred in prefix resolution and update processing.	Issues error messages and stops processing. Does not restore the authorization flags.	Identify the error that occurred in prefix resolution and update processing, and correct the error.  Recover the database by using the image copy that was taken before the Pre-reorganization utility was run.  Rerun all the jobs including Pre-reorganization utility, Smart Reorg utility, IPR DB Scan utility, and Post-reorganization utility jobs.
Errors occurred in image copy processing.	Issues error messages and stops processing. Does not restore the authorization flags.	Identify the error that occurred in image copy processing, and correct the error.  Create image copies of processed database data sets manually by using IMS HP Image Copy.
Pointer errors were found during HASH pointer check.	Issues error messages and stops processing. Does not restore the authorization flags.	Recover the database by using the image copy that was taken before the Pre-reorganization utility was run.  Collect the reports that were generated by all reorganization-related jobs including the Pre-reorganization utility, the Smart Reorg utility, the IPR DB Scan utility, and the Post-reorganization utility job, and contact IBM Software Support.



# Chapter 16. Pre-reorganization utility JCL requirements

To use the Pre-reorganization utility, supply an EXEC statement with PARM parameters, and appropriate DD statements.

## EXEC statement

The EXEC statement marks the beginning of a step within a job, and specifies the name of a program to be run.

The EXEC statement for the Pre-reorganization utility must be in the following format:

```
//stepname EXEC PGM=HPSCMAIN,PARM='FUNC=PR'
```

Specify HPSCMAIN as the program name. The PARM parameter must include the following keyword:

### FUNC=PR

Invokes the Pre-reorganization utility function.

You can specify the following optional keywords to specify the job step environment:

### IMSID=*ssna*

Specifies the subsystem name of the IMS control region.

If this parameter is not specified, the default setting that is determined by the IMS system generation is used.

If you specify IMSCMD=YES, the Pre-reorganization utility uses the IMS subsystem name to issue IMS commands.

For more information, see the following topics:

- [“IMSCMD control statement” on page 140](#)
- [“Setting up for using E-MCS console for IMS command processing” on page 50](#)

### IMSPLEX=*name*

Specifies the 1- to 5-character IMSplex name that is used by IMS DBRC SCI Registration.

### DBRCGRP=*ccc*

Specifies the 3-character DBRC group identifier that is used by IMS DBRC SCI Registration.

### DFSDF=*ccc*

Specifies the 3-character suffix of the DFSDF*ccc* member of the IMS.PROCLIB data set. You must also specify the PROCLIB DD statement.

## DD statements

DD statements identify the source of input and the placement of output information.

The following table shows DD statements and record format for the Pre-reorganization utility. The description of each DD statement follows the table.

Table 37. DD statements and record format for the Pre-reorganization utility

DDNAME	Use	Format	Need
STEPLIB	Input		Required
DFSRESLB	Input	Same as IMS	Optional (See <a href="#">Note 1</a> )
IMS	Input	Same as IMS	Required

Table 37. DD statements and record format for the Pre-reorganization utility (continued)

DDNAME	Use	Format	Need
IMSDALIB	Input	Same as IMS	Optional (See Note 2)
RECONx	Input	Same as IMS	Optional (See Note 3)
DFSURCDS	Input	LRECL=1600	Required
HPSIN	Input	LRECL=80, RECFM=FB	Required
PROCLIB	Input	LRECL=80, RECFM=FB	Optional
HPSGCTL	Output	LRECL=800, RECFM=FB	Required
HPSOUT	Output	LRECL=81	Optional (See Note 4)
HPSOUT2	Output	LRECL=133	Optional (See Note 4)
SYSUDUMP	Output	LRECL=133	Optional

**Notes:**

1. If a library that is concatenated to STEPLIB is not APF-authorized, the DFSRESLB DD statement is needed.
2. The IMSDALIB DD statement is valid for the RECON data sets.
3. If you use dynamic allocation, you do not need to specify the DD statement.
4. It is recommended that you do not specify these DD statements. If these DD statements are not specified, the Pre-reorganization utility dynamically allocates those DD statements to SYSOUT streams.

**STEPLIB DD**

Points to the following library data sets:

- IMS tools libraries:
  - IMS Database Reorganization Expert load module library (required)
  - IMS Tools Online System Interface load module library (optional)
  - The SHKTLOAD library of IMS Tools Base (optional)
- IMS RESLIB library (required)
- The library that contains DFSMDA members for dynamic allocation (optional)

**Recommendation:** If you specify this library on the IMSDALIB DD statement, remove the library from the STEPLIB concatenation.

- The library that contains an Installation Default Option Table (HPSGOPTI) (optional)

If you specify one or more of the following options, the libraries that are specified on the STEPLIB DD statement must be APF-authorized:

- HPIO=YES
- IMSCMD=YES

**DFSRESLB DD**

Points to an authorized library that contains IMS SVC modules. For an IMS Database Reorganization Expert job, IMS RESLIB library and any data set that is concatenated to it on the DFSRESLB DD statement must be APF-authorized. For details, see the topic that explains how to specify the DFSRESLB DD statement in IMS batch procedures in *IMS System Definition* for the version of IMS that you are using.

**IMS DD**

Describes the library that contains the DBDs that will be processed by the Pre-reorganization utility. All DBDs that belong to the logical group that is to be processed by the Pre-reorganization utility must be included in this library. This data set must reside on a direct-access device.

**IMSDALIB DD**

Specifies the partitioned data sets that contain dynamic allocation members for the database data sets of the RECON data sets.

If an IMSDALIB control statement is coded, IMSDALIB is always referred to by DBRC, and DBRC determines the data sets to allocate for each RECON DD.

**RECONx DD**

Defines DBRC RECON data sets. RECON data sets must be the same as the ones the online system is using. Do not use these RECON data set DD names if you want them to be allocated dynamically.

**Recommendation:** Let IMS Database Reorganization Expert allocate these data sets dynamically.

**DFSURCDS DD**

Defines the control data set that contains the data that was generated by the IMS Database Preorganization utility (DFSURPRO). This DD statement must be specified. This data set must reside on a direct-access device. This data set must contain information about one logical group; information about two or more logical groups must not be included in one control data set.

**HPSIN DD**

Defines the data set that contains control statements that specify options for the Pre-reorganization utility, the Smart Reorg utility, and the Post-reorganization utility.

**PROCLIB DD**

Points to the IMS.PROCLIB data set. If you specify DFSDF=ccc in the EXEC statement, you must also specify this DD statement and ensure that the DFSDFccc member exists in the IMS.PROCLIB data set.

**HPSGCTL DD**

Defines the control data set that contains the data that is to be generated by the Pre-reorganization utility. The data set is required for the subsequent Smart Reorg utility, IPR DB Scan utility, and Post-reorganization utility jobs. This data set must reside on a direct-access device.

**HPSOUT DD**

Defines the statistics output data set. The data set can reside on a tape, a direct-access device, or it can be routed through the output stream. If the DD statement is not coded, it is dynamically allocated to the SYSOUT stream of the output class that is specified by the MSGCLASS parameter on the JOB statement.

**HPSOUT2 DD**

Defines the secondary statistics output data set. The data set contains the reports and statistics. The data set can reside on a tape, a direct-access device, or it can be routed through the output stream. If the DD statement is not coded, it is dynamically allocated to the SYSOUT stream of the output class that is specified by the MSGCLASS parameter on the JOB statement.

**SYSUDUMP DD**

Defines a dump data set. Most errors encountered ends the program by issuing an ABEND macro with the DUMP operand. Only a SYSUDUMP DD statement is needed. The SYSABEND DD statement is not required.





---

# Chapter 17. Pre-reorganization utility control statements

The control statements for the Pre-reorganization utility are specified in the HPSIN data set. The control statements that you specify for the Pre-reorganization utility job also apply to the subsequent Smart Reorg utility and the Post-reorganization utility jobs.

The control statements that are specified in the HPSIN data set are divided into the following blocks, which must be specified in the order shown.

## **(REORG) block**

Specifies the control statements for the Pre-reorganization utility. These control statements also apply to subsequent Smart Reorg utility and Post-reorganization utility jobs.

## **(PREFIXRES) block**

Specifies the control statements for the Prefix Resolution task. The Prefix Resolution task is called in the subsequent Post-reorganization utility job.

Each block of control statement starts with a block identifier, which is the name of the block in parentheses starting in column 1. The control statement blocks must be specified in the following format:

```
//HPSIN DD *
(REORG)
... Control statements for the Pre-reorganization utility ...
(PREFIXRES)
... Control statements for the Prefix Resolution task ...
/*
```

For information about the general syntax of control statements, see [“Control statement syntax for the HPSIN data set”](#) on page 118.

### **Topics:**

- [“Control statements for the \(REORG\) block”](#) on page 305
- [“Control statements for the \(PREFIXRES\) block”](#) on page 311

---

## Control statements for the (REORG) block

The control statement block for the Pre-reorganization utility contains the user specifications for controlling the processes of the Pre-reorganization utility, the Smart Reorg utility, and the Post-reorganization utility.

The control statement block for the Pre-reorganization utility starts with a line that specifies the block name (REORG).

You do not need to specify the following control statements because the options specified by these control statements are always applied when running the Post-reorganization utility:

- NAMESWAP
- PREFIXRES

The following table shows the control statements that you can specify in the (REORG) block.

Except for the WORKHLQ, WORKUNIT, and WORKVOL control statements, the functions of these control statements are the same as the Smart Reorg utility control statements.

If the ITKBSRVR control statement is specified, the Pre-reorganization utility and the Smart Reorg utility store reports in the Output repository of the IMS Tools KB server.

If both ADXCFGRP and ADDBGRP control statements are specified, the Pre-reorganization utility, the Smart Reorg utility, the IPR DB Scan utility, and the Post-reorganization utility send a system notification to Autonomics Director.

Table 38. Control statements for the Pre-reorganization utility

<b>Keyword</b>	<b>Acceptable values</b>	<b>Default</b>	<b>Description</b>
ADDBGRP	<i>dbgrpname</i> or *NO	*NO	Specifies the database group name defined in Autonomics Director. See <a href="#">“ADDBGRP control statement”</a> on page 127.
ADXCFGRP	<i>xcfgrpname</i> or *NO	*NO	Specifies the XCF group name of the Autonomics Director server. See <a href="#">“ADXCFGRP control statement”</a> on page 127.
AUTHFAIL	WTOR or ABORT	ABORT	Specifies the action the Pre-reorganization and Post-reorganization utilities take when DBRC authorization fails during initialization processing and before the name swapping. See <a href="#">“AUTHFAIL control statement”</a> on page 128.
DALUNIT	<i>group_name</i> or <i>device_type</i>	SYSALLDA	Specifies a device that is used for dynamic allocation as a group name or a device type. See <a href="#">“DALUNIT control statement”</a> on page 131.
DBRCAUTHCMD	YES or NO	NO	Specifies whether the Pre-reorganization utility issues a CHANGE.DB READON or a CHANGE.DB NOAUTH command and the Post-reorganization utility issues a CHANGE.DB NOAUTH command before the name swapping. See <a href="#">“DBRCAUTHCMD control statement”</a> on page 131.
DBSHARE	YES or NO	NO	Specifies whether to allow read-only access to the database while it is being reorganized. See <a href="#">“DBSHARE control statement”</a> on page 132.

Table 38. Control statements for the Pre-reorganization utility (continued)

Keyword	Acceptable values	Default	Description
DELOLDDS	YES or NO	NO	Specifies whether to delete the input old database data sets after successful reorganization. See <a href="#">“DELOLDDS control statement”</a> on page 135.
DISPOLDDS	DELETE NEWSHADOW TEMPNAME	TEMPNAME	Specifies the disposition of the original data sets after a successful reorganization. See <a href="#">“DISPOLDDS control statement”</a> on page 135.
HPIO	YES or NO	None	Specifies whether to use the High Performance I/O Driver in all subtasks that support it. See <a href="#">“HPIO control statement”</a> on page 137.
IC	YES or NO	NO	Specifies whether image copy processing is called. See <a href="#">“IC control statement”</a> on page 138.
ICNEEDED	ON or OFF	<ul style="list-style-type: none"> <li>• ON for recoverable (RECOVABL) databases</li> <li>• OFF for non-recoverable (NONRECOV) databases</li> </ul>	Specifies whether the DBRC ICNEEDED flag is set on after data set name swapping. See <a href="#">“ICNEEDED control statement”</a> on page 138.
IMSCMD	NO YES,EMCS YES,TOSI	NO	Specifies whether the Pre-reorganization utility issues a /DBR or /DBD command at the beginning of the reorganization and the Post-reorganization utility issues a /DBR command before name swapping. See <a href="#">“IMSCMD control statement”</a> on page 140.
IMSCMDOPT	<i>a,b</i> <i>a</i> =ALL, DBD, DBR, or STA <i>b</i> =LOCAL or GLOBAL	None	Specifies the option parameters for the IMS commands that are issued by the IMS Tools Online System Interface. See <a href="#">“IMSCMDOPT control statement”</a> on page 142.

Table 38. Control statements for the Pre-reorganization utility (continued)

Keyword	Acceptable values	Default	Description
INDEXBLD	NO YES,CURRENT YES,NEW	NO	Specifies whether all secondary indexes for the database are to be rebuilt in the Smart Reorg utility job step. See <a href="#">“INDEXBLD control statement”</a> on page 143.
ITKBDATA	UTILHIST or *NO	*NO	Specifies the type of additional data to store in the IMS Tools Base IMS Tools Knowledge Base repository. See <a href="#">“ITKBDATA control statement”</a> on page 143.
ITKBLOAD	<i>libname</i> or *NO	*NO	Specifies the library name of IMS Tools KB. See <a href="#">“ITKBLOAD control statement”</a> on page 144.
ITKBSRVR	<i>servername</i> or *NO	*NO	Specifies the name of the IMS Tools KB server XCF group. See <a href="#">“ITKBSRVR control statement”</a> on page 144.
LASTAUTHFLAG	OFF or ORIGINAL	OFF	Specifies the state of the READ ONLY flag and the PROHIBIT AUTHORIZATION flag in the RECON data sets after post-reorganization processing ends. See <a href="#">“LASTAUTHFLAG control statement”</a> on page 146.
NAMESWAPFAIL	WTOR ABORT BACKOUT	ABORT	Specifies the action taken in case name swapping error occurs. See <a href="#">“NAMESWAPFAIL control statement”</a> on page 148.
STARTDB	YES or NO	NO	Specifies whether a / START DB command is issued automatically. See <a href="#">“STARTDB control statement”</a> on page 158.

Table 38. Control statements for the Pre-reorganization utility (continued)

Keyword	Acceptable values	Default	Description
TOSITEST	<i>(max, interval)</i>	(1,1)	Specifies the maximum number of attempts and the interval time for Reorganization Manager to verify whether the database is being used. See <a href="#">“TOSITEST control statement”</a> on page 160.
TOSIWAIT	0 - 9999	300	Specifies the IMS Tools Online System Interface response timeout value in seconds. See <a href="#">“TOSIWAIT control statement”</a> on page 160.
TOSIXCFGRP	<i>grpname</i>	None	Specifies the XCF group name to be used by the IMS Tools Online System Interface. See <a href="#">“TOSIXCFGRP control statement”</a> on page 161.
WORKHLQ	<i>high_level_qualifier</i>	HPS.POSTRERG	Specifies the high-level qualifier for the result data sets. See <a href="#">“WORKHLQ control statement”</a> on page 310.
WORKUNIT	<i>device_type</i>	SYSALLDA	Specifies the device type or the device group name that is used for dynamically allocating the result data sets. See <a href="#">“WORKUNIT control statement”</a> on page 310.
WORKVOL	<i>volume_serial</i>	None	Specifies the volume serial number that is used for dynamically allocating the result data sets. See <a href="#">“WORKVOL control statement”</a> on page 310.

**Note:** Certain control statements that are not listed in the table can be specified in Smart Reorg utility JCL. See [“Control statement considerations”](#) on page 325.

The following control statements are not supported in Pre-reorganization jobs or in Smart Reorg utility jobs that run after Pre-reorganization jobs:

- CONDREORG
- ICTYPE
- PARTITION
- ILDSBLD

## WORKHLQ control statement

Specifies the high-level qualifier for the result data sets that are allocated dynamically by the Pre-reorganization utility.

This control statement is optional. The default is WORKHLQ=HPS.POSTRERG.

➤ WORKHLQ=  HPS.POSTRERG  
hlq\_name ➤

*hlq\_name* specifies the high-level qualifier for the result data sets. The maximum length is 23 characters.

Result data sets are dynamically allocated with either of the following names:

- *hlq\_name*.RSL.*dbdname*
- HPS.POSTRERG.RSL.*dbdname*

*dbdname* is the name of the DBD that is reorganized by the Smart Reorg utility or scanned by the IPR DB Scan utility.

### Related concepts

#### Result data sets

The result data sets are created dynamically by the Pre-reorganization utility. These data sets contain execution results of subsequent Smart Reorg utility jobs or IPR DB Scan utility jobs and information that is required for running the Post-reorganization utility.

## WORKUNIT control statement

Specifies the device type or the device group name that is used for dynamically allocating the result data sets.

This control statement is optional. The default is WORKUNIT=SYSALLDA.

➤ WORKUNIT=  SYSALLDA  
unit\_name ➤

*unit\_name* specifies the device type or the device group name that is used for dynamically allocating the result data sets.

SYSALLDA is an IBM assigned group name that contains all direct-access devices that are defined to the system.

### Related concepts

#### Result data sets

The result data sets are created dynamically by the Pre-reorganization utility. These data sets contain execution results of subsequent Smart Reorg utility jobs or IPR DB Scan utility jobs and information that is required for running the Post-reorganization utility.

## WORKVOL control statement

Specifies the volume serial number that is used for dynamically allocating the result data sets.

This control statement is optional. If you do not specify this control statement, the result data sets are dynamically allocated with nonspecific volume requests.

➤ WORKVOL= *serial\_number* ➤

*serial\_number* specifies the volume serial number that is used for dynamically allocating the result data sets.

## Related concepts

### Result data sets

The result data sets are created dynamically by the Pre-reorganization utility. These data sets contain execution results of subsequent Smart Reorg utility jobs or IPR DB Scan utility jobs and information that is required for running the Post-reorganization utility.

## Control statements for the (PREFIXRES) block

The control statement block for the Prefix Resolution task contains the user specifications for controlling the prefix update and resolution processes.

The following table shows the control statements that you can specify in the (PREFIXRES) block for the Prefix Resolution task. For details about the control statements, see the *IMS High Performance Prefix Resolution User's Guide*.

Table 39. Control statements for Prefix Resolution task

Keyword	Acceptable values	Default	Description
ALLOWLC	YES or NO	NO	Specifies whether to allow logical children with no logical parent.
ALLOWLP	YES or NO	YES	Specifies whether to allow logical parents with no logical child.
AVGLEN	1 - 999	No default	Specifies the estimated average length of logical pointer records that are created by Reload task.
FILSZ	1 - 999999999	No default	Specifies the estimated number of logical pointer records that are created by Reload task.
HPPRBH	YES or NO	YES	Specifies whether to use the HPPR buffer handler to update the OSAM data sets. To process OSAM large format sequential data sets, HPPRBH=NO must be specified.
OPRTLC	YES or NO	YES	Specifies whether to print orphan logical children.
OPRTL P	YES or NO	NO	Specifies whether to print orphan logical parents.
UPDLPC	YES or NO	YES	Specifies whether to update counter fields in logical parents.





---

# Chapter 18. Post-reorganization utility JCL requirements

To use the Post-reorganization utility, supply an EXEC statement with PARM parameters, and appropriate DD statements.

## EXEC statement

The EXEC statement marks the beginning of a step within a job, and specifies the name of a program to be run.

The EXEC statement for the Post-reorganization utility must be in the following format:

```
//stepname EXEC PGM=HPSCMAIN,PARM='FUNC=PO'
```

Specify HPSCMAIN as the program name. The PARM parameter must include the following keyword:

### **FUNC=PO**

Invokes the Post-reorganization utility function.

You can specify the following optional keywords to specify the job step environment:

### **IMSID=ssna**

Specifies the subsystem name of the IMS control region.

If this parameter is not specified, the default setting that is determined by the IMS system generation is used.

If you specify IMSCMD=YES, the Post-reorganization utility uses the IMS subsystem name to issue IMS commands.

For more information, see the following topics:

- [“IMSCMD control statement” on page 140](#)
- [“Setting up for using E-MCS console for IMS command processing” on page 50](#)

### **IMSPLEX=name**

Specifies the 1- to 5-character IMSplex name that is used by IMS DBRC SCI Registration.

### **DBRCGRP=ccc**

Specifies the 3-character DBRC group identifier that is used by IMS DBRC SCI Registration.

### **SWAP=x**

Makes the address space swappable or non-swappable.

#### **Y**

The address space is swappable.

#### **N**

The address space is non-swappable.

The default is N.

### **IRLM=x**

Specifies whether the Unload task uses the internal resource lock manager (IRLM) when native DL/I calls are issued for the database.

#### **Y**

IRLM is used.

#### **N**

IRLM is not used.

If IRLM parameter is not specified, the default setting that is determined by the IMS system generation is used.

**IRLMNM=irlm**

If IRLM=Y is specified, this parameter specifies the IRLM subsystem name (a 1- to 4-alphanumeric character name). If this parameter is not specified, the default setting that is determined by the IMS system generation is used.

**GSGNAME=gsgname**

Specifies the name of the global service group (GSG).

If this parameter is not specified, the default setting that is determined by the IMS system generation is used.

**DFSDF=ccc**

Specifies the 3-character suffix of the DFSDFccc member of the IMS.PROCLIB data set. You must also specify the PROCLIB DD statement.

**Tip:** To specify the IMSplex name, you can also use the DBRC SCI Registration exit. For more information, see [“Setting up the DBRC command authorization”](#) on page 47.

**DD statements**

DD statements identify the source of input and the placement of output information.

The following table shows DD statements and record format for the Post-reorganization utility. The description of each DD statement follows the table.

*Table 40. DD statements and record format for the Post-reorganization utility*

<b>DDNAME</b>	<b>Use</b>	<b>Format</b>	<b>Need</b>
STEPLIB	Input		Required
DFSRESLB	Input	Same as IMS	Optional (See <a href="#">Note 1</a> )
IMS	Input	Same as IMS	Required
IMSDALIB	Input	Same as IMS	Optional (See <a href="#">Note 2</a> )
RECONx	Input	Same as IMS	Optional (See <a href="#">Note 3</a> )
PROCLIB	Input	LRECL=80, RECFM=FB	Optional
DFSACBPD	Input	LRECL=80, RECFM=FB	Optional
DFSURWF1	Input	Same as IMS	Optional
DFSURCDS	Input	LRECL=1600	Optional
DFSCTL	Input	Same as IMS	Optional (See <a href="#">Note 4</a> )
DFSVSAMP	Input	Same as IMS	Optional (See <a href="#">Note 4</a> )
HPSGCTL	Input	LRECL=800, RECFM=FB	Required
HPSOUT	Output	LRECL=81	Optional (See <a href="#">Note 5</a> )
HPSOUT2	Output	LRECL=133	Optional (See <a href="#">Note 5</a> )
SYSUDUMP	Output	LRECL=133	Optional

Table 40. DD statements and record format for the Post-reorganization utility (continued)

DDNAME	Use	Format	Need
--------	-----	--------	------

**Notes:**

1. If a library that is concatenated to STEPLIB is not APF-authorized, the DFSRESLB DD statement is needed.
2. The IMSDALIB DD statement is valid for the RECON data sets.
3. If you use dynamic allocation, you do not need to specify the DD statement.
4. This DD statement is used when HPPRBH=NO is specified in the (PREFIXRES) block of the HPSIN data set for the Pre-reorganization utility.
5. It is recommended that you do not specify these DD statements. If these DD statements are not specified, the Post-reorganization utility dynamically allocates those DD statements to SYSOUT streams.

### STEPLIB DD

Points to the following library data sets:

- IMS tools libraries:
  - IMS Database Reorganization Expert load module library (required)
  - IMS Library Integrity Utilities load module library (optional)
  - IMS HP Image Copy load module library (optional)
  - IMS HP Pointer Checker load module library (optional)
  - IMS HP Prefix Resolution load module library (optional)
  - IMS Tools Online System Interface load module library (optional)
  - The SHKLOAD library of IMS Tools Base (optional)
- IMS RESLIB library (required)
- The library that contains DFSMDA members for dynamic allocation (optional)

**Recommendation:** If you specify this library on the IMSDALIB DD statement, remove the library from the STEPLIB concatenation.

- The load module library that contains user routines (optional)

If you specify one or more of the following options, the libraries that are specified on the STEPLIB DD statement must be APF-authorized:

- HPIO=YES
- IMSCMD=YES

### DFSRESLB DD

Points to an authorized library that contains IMS SVC modules. For an IMS Database Reorganization Expert job, the IMS RESLIB library and any data set that is concatenated to it on the DFSRESLB DD statement must be APF-authorized. For details, see the topic that explains how to specify the DFSRESLB DD statement in IMS batch procedures in *IMS System Definition* for the version of IMS that you are using.

### IMS DD

Describes the library that contains the DBDs that will be processed by the Post-reorganization utility. All DBDs that belong to the logical group that is to be processed by the Post-reorganization utility must be included in this library. This data set must reside on a direct-access device.

### IMSDALIB DD

Specifies the partition data sets that contain dynamic allocation members for the database data sets of the RECON data sets.

If an IMSDALIB control statement is coded, IMSDALIB is always referred to by DBRC, and DBRC determines the data sets to allocate for each RECON DD.

**RECONx DD**

Defines DBRC RECON data sets. RECON data sets must be the same as the ones the online system is using. Do not use these RECON data set DD names if you want to have them allocated dynamically.

**Recommendation:** Let IMS Database Reorganization Expert allocate these data sets dynamically.

**PROCLIB DD**

Points to the IMS.PROCLIB data set. If you specify DFSDF=ccc in the EXEC statement, you must also specify this DD statement and ensure that the DFSDFccc member exists in the IMS.PROCLIB data set.

**DFSACBPD DD**

Defines the control statement data set to be used in an IMS-managed ACBs environment. STAGING is the only valid keyword and is applied when REORGINPUT=ULDS is specified in the (REORG) block of the HPSIN data set. The keyword specifies to obtain the database definition from the IMS catalog staging data sets and not from the IMS catalog directory data sets.

**DFSURWF1 DD**

Defines the work data sets that are generated by the Smart Reorg utility or the IPR DB Scan utility. The data sets are used as input to the IMS HP Prefix Resolution utility to resolve logical relationships. If this DD statement is not coded, the work data sets are dynamically allocated. If the DD statement is coded, all DFSURWF1 data sets that are generated by the Smart Reorg utility or the IPR DB Scan utility must be concatenated to DFSURWF1 DD. The work data sets must reside on either a tape or a direct-access device.

**DFSURCDS DD**

Defines the control data set that contains the data that was generated by the IMS Database Preorganization utility (DFSURPRO). If this DD statement is not coded, the data set is dynamically allocated.

**DFSCTL DD**

This data set is used as input for IMS OSAM sequential buffering when HPPRBH=NO is specified in the (PREFIXRES) block of the HPSIN data set for the Pre-reorganization utility.

If HPPRBH=NO is specified but this DD statement is not coded, a DFSCTL data set is dynamically allocated by IMS HP Prefix Resolution. For the contents of the data set, see the *IMS High Performance Prefix Resolution User's Guide*.

**DFSVSAMP DD**

Describes the data set that contains the buffer pool information required by the IMS DL/I buffer handler. If HPPRBH=NO is specified in the (PREFIXRES) block of the HPSIN data set for the Pre-reorganization utility, this data set is required.

If HPPRBH=NO is specified but this DD statement is not coded, a DFSVSAMP data set is dynamically allocated by IMS HP Prefix Resolution. For the contents of the data set, see the *IMS High Performance Prefix Resolution User's Guide*.

**HPSGCTL DD**

Defines the control data set that contains the data that was generated by the Pre-reorganization utility. This DD statement must be specified. This data set must reside on a direct-access device. This data set is deleted when Post-reorganization utility processing completes successfully.

**HPSOUT DD**

Defines the statistics output data set. The data set can reside on a tape, a direct-access device, or it can be routed through the output stream. If the DD statement is not coded, it is dynamically allocated to the SYSOUT stream of the output class that is specified by the MSGCLASS parameter on the JOB statement.

**HPSOUT2 DD**

Defines the secondary statistics output data set. The data set contains the reports and statistics. The data set can reside on a tape, a direct-access device, or it can be routed through the output stream. If the DD statement is not coded, it is dynamically allocated to the SYSOUT stream of the output class that is specified by the MSGCLASS parameter on the JOB statement.

**SYSUDUMP DD**

Defines a dump data set. Most errors encountered end the program by issuing an ABEND macro with the DUMP operand. Only a SYSUDUMP DD statement is needed. The SYSABEND DD statement is not required.



---

## Chapter 19. Post-reorganization utility control statements

You do not need to code control statements in the HPSIN data set in Post-reorganization utility JCL. The HPSIN control statements that are specified in Pre-reorganization utility JCL are automatically applied to the Post-reorganization utility run.

You can specify the control statements for image copy processing and HASH pointer checking on the ICEIN DD statement.

### Topics:

- [“Control statements for the Image Copy task” on page 319](#)
- [“Control statements that affect HASH pointer checking” on page 321](#)
- [“Considerations for database data sets” on page 322](#)

---

### Control statements for the Image Copy task

The control statement block for the Image Copy task contains the user specifications for controlling the image copy process.

The image copy process is activated by specifying IC=YES in the (REORG) block of the HPSIN data set in the Pre-reorganization utility JCL. The control statements for the image copy process are coded in the ICEIN data set of the Post-reorganization utility JCL.

If the system default values are suitable for your requirements, you do not need to code any statements except the allocation information for the image copy data set.

The default values can be changed by creating a GLOBAL site default table (FABJGLB0) for IMS HP Image Copy. If you create an FABJGLB0 module and specify the library that contains the module on the STEPLIB DD, IMS HP Image Copy merges it with the system default values of IMS Database Reorganization Expert.

**Recommendation:** There are no default values for allocating the image copy data set. Define the allocation information in the GLOBAL site default table or on the GLOBAL statement in the ICEIN data set.

The following control statements are used by default when IMS HP Image Copy is called by the Post-reorganization utility:

- AIC (Parallel Image Copy) control statement for all DBDSs
- ICOUT=\* parameter
- UNIT=SYSALLDA parameter
- HDPC=Y parameter

The default values of other ICEIN control statement parameters except for the compression routine (COMPRTN= parameter) are the same as the values used by the stand-alone IMS HP Image Copy.

### Notes:

- If an IC control statement is specified, the image copy function works in serial mode; if an AIC control statement is specified, the image copy function works in parallel mode.
- If a WAIT control statement is specified, the image copy control task waits for all subtasks that are activated by the AIC control statements and that are coded above the WAIT statement to complete before starting the image copy processes that are identified by the subsequent AIC control statements.
- If you specify COMP=Y in the site default table or the ICEIN DD statement, the default compression routine is FABJCMP3.

See the following topics to learn more about image copy processing:

- Image copy processing that is supported by the Post-reorganization utility is introduced in [“Image copy processing and HASH pointer checking”](#) on page 290.
- For the ICEIN control statements, their syntax, and the parameters that are supported by the Post-reorganization utility, see the *IMS High Performance Image Copy User's Guide*.
- For more information about the site default table, see the topic "Setting default values for the FABJMAIN program" in the *IMS High Performance Image Copy User's Guide*.

Subsections:

- [“Image copy process and DBRC”](#) on page 320
- [“REORG and Image Copy timestamps”](#) on page 320

## Image copy process and DBRC

If IC=YES is specified in Pre-reorganization utility JCL, the ICNEEDED control statement is ignored, and DBRC notification processing is done based on the following information:

- How the database or index is registered to DBRC
- How the HDPC parameter is specified in the ICEIN data set
- How the VIC parameter is specified in the ICEIN data set

If IC=YES is specified in the Pre-reorganization utility JCL, the image copy data sets of primary DSGs are always created. DBRC is always notified about the reorganization, and regardless of whether the database is registered as RECOVABL or NONRECOV, the image copy data sets are always registered by NOTIFY.IC commands.

For the HIDAM primary index and the secondary indexes of HDAM and HIDAM databases, the image copy process is based on the following definitions:

- HDPC=Y or O
- VIC=N or Y
- RECOVABL or NONRECOV in DBRC database registration
- ICREQ or NOICREQ (for the database that is registered to DBRC as NONRECOV)

The system default for the HDPC and VIC parameters for the Post-reorganization utility are HDPC=Y and VIC=N. For more information about the HDPC parameter in the Post-reorganization utility, see [“Control statements that affect HASH pointer checking”](#) on page 321.

The recommended combinations are:

- If you need image copies of indexes, register the indexes to DBRC as RECOVABL, and accept the system default for the HDPC and VIC parameters.
- If you do not need image copies of an index, register the index to DBRC as NONRECOV and NOICREQ, and specify HDPC=O and VIC=N on the GLOBAL statement or the IC statement for the index. In this case, the DBRC REORG record is created without setting the IC NEEDED flag, but an IC or UIC (user image copy) record is not created for the index. You can reduce the number of unnecessary UIC records in the RECON data sets.
- If you do not need image copies of an index but want a UIC record, register the index to DBRC as NONRECOV and NOICREQ, and specify HDPC=Y, VIC=Y, and the VICNAME parameter on the GLOBAL statement or the IC statement for the index. In this case, both the DBRC REORG record without the IC NEEDED flag set and UIC record with the user data supplied by VICNAME are created for the index.

## REORG and Image Copy timestamps

The DBRC REORG and IC timestamps that are set by the Post-reorganization utility are different from the timestamps set by the standard IMS reorganization utilities.

The following figure shows when each timestamp is taken during image copy processing. The REORG timestamp is taken immediately before image copy processing is started. The IC timestamp is taken



approximately 3 seconds after the REORG timestamp is taken, which is also before image copy processing is started.

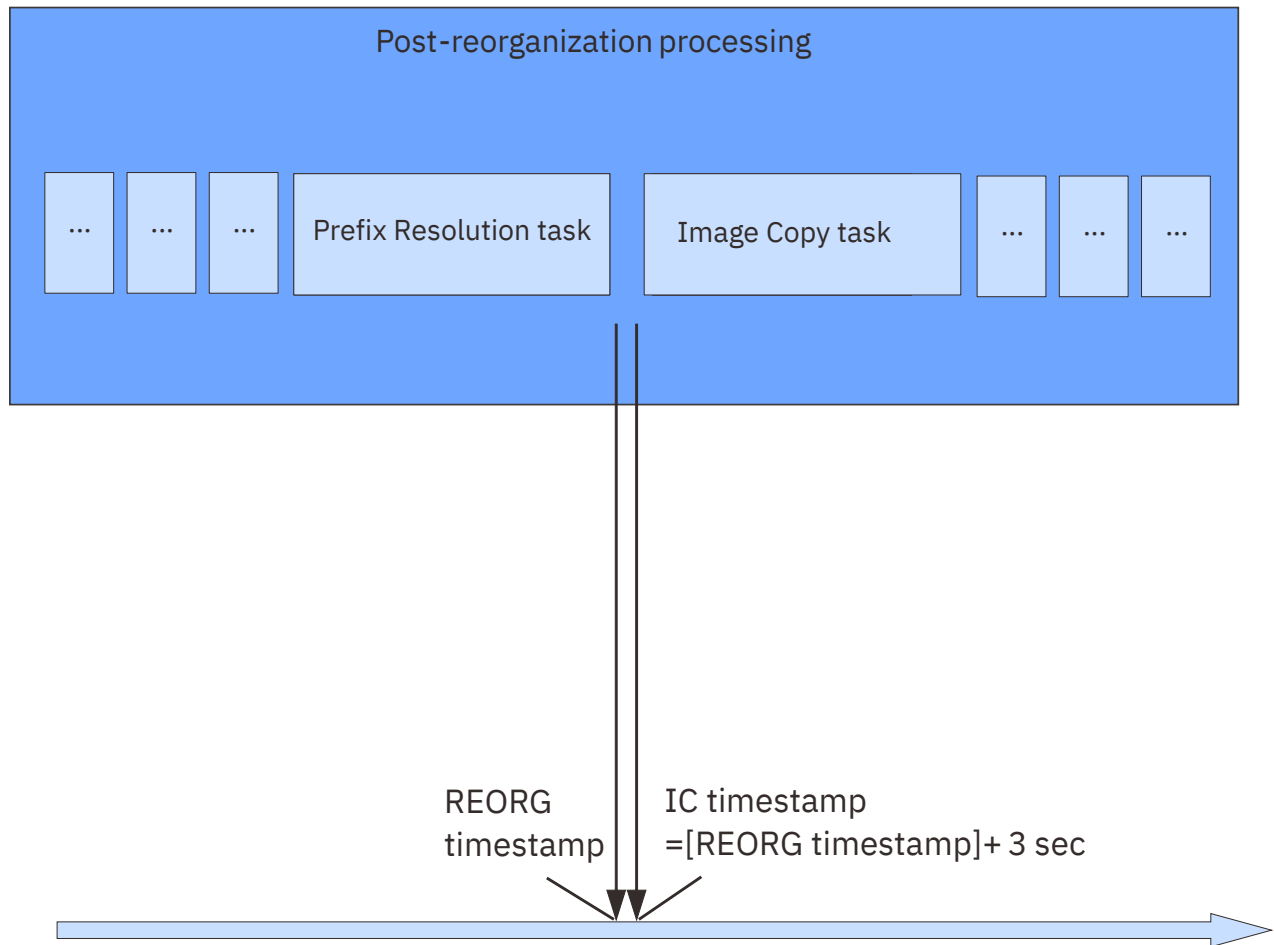

Figure 104. REORG and IC timestamps during Post-reorganization processing

The timestamps that are used for the RUNTIME parameter for the NOTIFY.REORG, NOTIFY.IC, and NOTIFY.UIC commands are in local time and in punctuated format. For more information about the standard timestamp format, see the topic "DBRC time stamps" in *IMS Commands*.

## Control statements that affect HASH pointer checking

HASH pointer checking for the reorganized database and indexes is activated by the HDPC=Y IMS HP Image Copy control statement parameter.

The HDPC parameter can be specified on the GLOBAL, the IC, or the AIC control statement in the ICEIN data set. HDPC=Y on the GLOBAL control statement applies to all data sets including indexes. HDPC=Y on the IC or the AIC control statement applies to the data set that is identified by the control statement.

If you specify IC=YES in the (REORG) block of the HPSIN data set, HDPC=Y on the GLOBAL control statement is used as the system default and HASH pointer checking is invoked. If an appropriate version of IMS HP Pointer Checker is not installed, the HDPC=Y parameter is ignored.

To run HASH pointer checking on indexes without creating an image copy data set of the indexes, specify HDPC=O instead of HDPC=Y.

You can control the report output by specifying suboptions in the HDPC parameter. For details, see ["Reports from the optional tasks" on page 341](#).

When HASH pointer checking is called within a Post-reorganization utility job, the following IMS HP Pointer Checker messages are suppressed: FABP1370I, FABP1380I, FABP1410I, FABP1420I, FABP1440I, FABP1450I, and FABP4011I.

For more information about the HDPC parameters, see the *IMS High Performance Image Copy User's Guide*.

For more information about supported versions of IMS HP Pointer Checker, see [“Software prerequisites” on page 39](#).

## Considerations for database data sets

---

The Post-reorganization utility uses database data sets and DD names in specific ways. These explanations help you build your JCL correctly.

Subsections:

- [“Name swapping for database data sets” on page 322](#)
- [“Dynamic allocation of database data sets” on page 322](#)
- [“Data sets after reorganization” on page 322](#)

### Name swapping for database data sets

The Post-reorganization utility swaps the data set names immediately after quiescing the database, which is before running the prefix resolution task.

For the databases that were reorganized by Smart Reorg utility jobs, the names of the primary database and primary index data sets and the names of shadow ones are swapped. The secondary index databases are swapped only if the IMS Index Builder task is activated and INDEXBLD=YES,NEW was specified when the Smart Reorg utility was run.

Each original data set name, including the VSAM component name, is renamed to the original name plus the suffix .T.

If name swapping fails, if NAMESWAPFAIL=BACKOUT was specified when the Pre-reorganization utility was run, the data set names are restored to the names the data set had when the name swapping process began.

For more information about the name swapping process and the control statements, see the following topics:

- [“NAMESWAP control statement” on page 147](#)
- [“NAMESWAPFAIL control statement” on page 148](#)

**Tip:** You can see how the data sets were renamed by the Post-reorganization utility by checking the Result of Name Swapping report. For more information, see [“Result of Name Swapping report \(Post-reorganization utility\)” on page 343](#).

### Dynamic allocation of database data sets

After the names are swapped, the Post-reorganization utility dynamically allocates all original database data sets that were reorganized by Smart Reorg utility jobs and scanned by IPR DB Scan utility jobs. Do not code the DD statements for original database data sets in Post-reorganization utility JCL because they are allocated dynamically by the Post-reorganization utility.

The allocated database data sets are used in prefix resolution and update processing and image copy processing.

### Data sets after reorganization

After prefix resolution and update processing or after image copy processing (activated when IC=YES is coded in Pre-reorganization utility JCL), you can have the renamed original data sets deleted or

renamed to the names of the shadow data sets. To do so, code the DISPOLDDS control statement in Pre-reorganization utility. For more information, see [“DISPOLDDS control statement”](#) on page 135.

**Related concepts**

[Process flow for reorganizing databases that have external logical relationships](#)

Reorganizing databases that have external logical relationships requires additional jobs that perform pre-reorganization processing and post-reorganization processing.



---

## Chapter 20. JCL considerations for the Smart Reorg utility and the IPR DB Scan utility

Certain considerations apply when using the Smart Reorg utility and the IPR DB Scan utility after the Pre-reorganization utility.

### Topics:

- [“Smart Reorg utility JCL considerations \(after running the Pre-reorganization utility\)” on page 325](#)
- [“IPR DB Scan utility JCL considerations \(after running the Pre-reorganization utility\)” on page 326](#)

---

### Smart Reorg utility JCL considerations (after running the Pre-reorganization utility)

---

You must run a Smart Reorg utility job for all the databases that are specified on the DBIL or the DBR control statement of IMS Database Prereorganization utility JCL (DFSURPRO utility JCL).

The Smart Reorg utility generates the result data set after completing the job. The result data set is used as an input to the Post-reorganization utility. For details, see [“Result data sets” on page 296](#).

For more information about the IMS Database Prereorganization utility (DFUSRPRO), see *IMS Database Utilities*.

### JCL requirements

In the Smart Reorg utility JCL stream, you must code an HPSGCTL DD statement that points to the HPSGCTL data set that was specified in the Pre-reorganization utility job. When the Smart Reorg utility detects an HPSGCTL DD statement in its JCL stream, the Smart Reorg utility skips post-reorganization processing, including data set name swapping, DBRC notification processing, image copy processing, and database restart processing.

The Smart Reorg utility uses DBRC. You must specify DBRC=Y for the EXEC parameter to activate DBRC.

### Control statement considerations

The control statements that are specified in the Pre-reorganization utility JCL are applied to the Smart Reorg utility run. For more information, see [Chapter 17, “Pre-reorganization utility control statements,” on page 305](#).

In the Smart Reorg utility job that follows a Pre-reorganization job, you can additionally specify the following control statements in the (REORG) block of the HPSIN data set:

- DDNMAP
- DECODEDBD
- DECODESXD
- DYNALLOC
- NEWDBD (See Note)
- PIPEBLKSZ
- PIPEDEPTH
- PIPEWAIT
- SINDEXSUF
- SPACEALLOC
- STATRL

- STATUL
- ZIIPMODE

**Note:** A NEWDBD control statement can be specified in the (REORG) block of the HPSIN data set of the Smart Reorg utility job that follows a Pre-reorganization job. However, only the following DBD changes are supported:

- Changing randomizing module name or randomizing parameters
- Changing segment compression parameters

In the Smart Reorg utility job, the DBD library containing the changed DBD must be concatenated to the DD statement specified by the NEWDBD control statement.

In the Post-reorganization job, the new DBD library must be concatenated to the IMS DD statement.

For more information about each control statement, see [“Control statements for the Smart Reorg Driver” on page 118.](#)

## IPR DB Scan utility JCL considerations (after running the Pre-reorganization utility)

---

You must run the IPR DB scan utility for the databases that were identified by the IMS Database Preorganization utility (DFSURPRO). The DFSURPRO utility issues a DFS862I message for each database that needs to be scanned. Locate this message to identify the databases to process.

The IPR DB Scan utility generates the result data set after completing the job. The result data set will be used as an input for the Post-reorganization utility. For details, see [“Result data sets” on page 296.](#)

For information about the IMS Database Preorganization utility (DFUSRPRO), see *IMS Database Utilities*.

### JCL requirements

In the IPR DB Scan utility JCL stream, you must code an HPSGCTL DD statement that points to the HPSGCTL data set that was specified in the Pre-reorganization utility job.

The IPR DB Scan utility uses DBRC. You must specify DBRC=Y for the EXEC parameter to activate DBRC.

# Chapter 21. Pre-reorganization utility and Post-reorganization utility JCL examples

Use the following examples to code JCL for reorganizing databases that have external logical relationships by using the Pre-reorganization utility and the Post-reorganization utility.

## Topics:

- [“Example 1: Reorganizing a database in a logical group” on page 327](#)
- [“Example 2: Reorganizing all databases in a logical group” on page 330](#)

## Example 1: Reorganizing a database in a logical group

This example provides the JCL streams for reorganizing all databases that belong to a logical group.

In this example, the following conditions are assumed:

- Database SAMPDB02 is to be reorganized.
- A unidirectional logical relationship is established between the SAMPDB01 and the SAMPDB02 databases.
- The segments of the SAMPDB01 database point to the segments in the SAMPDB02 database.

In this example, to reorganize database SAMPDB02, utility jobs are run in the following order:

1. [“IMS Database Prereorganization utility job \(DFSURPRO\)” on page 327](#)
2. [“Pre-reorganization utility job” on page 328](#)
3. [“Smart Reorg utility job” on page 328](#)
4. [“IPR DB Scan utility job” on page 329](#)
5. [“Post-reorganization utility job” on page 329](#)

### IMS Database Prereorganization utility job (DFSURPRO)

The following figure shows example JCL to run the IMS Database Prereorganization utility (DFSURPRO).

The DBR control statement specifies SAMPDB02, which is the database to be reorganized.

```
//PREREORG EXEC PGM=DFSRR00,  
//          PARM='ULU,DFSURPRO,,,,,,,,,,,,,Y,N'  
//STEPLIB DD DISP=SHR,DSN=IMS.SDFSRESL  
//IMSDALIB DD DISP=SHR,DSN=IMS.MDALIB  
//SDFSRESLB DD DISP=SHR,DSN=IMS.SDFSRESL  
//IMS DD DISP=SHR,DSN=IMS.DBDLIB  
//SYSPRINT DD SYSOUT=A  
//DFSURCDS DD DSN=USER.LG001.DFSURCDS,DISP=(NEW,CATLG),  
//          UNIT=SYSALLDA,SPACE=(TRK,(1,1)),DCB=BLKSIZE=1600  
//SYSIN DD *  
DBR=SAMPDB02  
OPTIONS=(NOPUNCH,STAT,SUMM)  
/*
```

Figure 105. JCL for the IMS Database Prereorganization utility (reorganizing a database in a logical group)

The DFSURPRO utility creates a control data set (DFSURCDS). This data set will be used by the subsequent Pre-reorganization utility job, the Smart Reorg utility job, the IPR DB Scan utility job, and the Post-reorganization utility job.

When the DFSURPRO utility job ends, you are notified that the SAMPDB01 database needs to be scanned to resolve logical relationships.

## Pre-reorganization utility job

The following figure shows example JCL to run the Pre-reorganization utility.

IMSCMD=YES,TOSI and DBSHARE=YES are specified to request that the Pre-reorganization utility issue /DBD commands.

```
//RGEPRE EXEC PGM=HPSCMAIN, PARM=' FUNC=PR'
//STEPLIB DD DISP=SHR, DSN=IMSTOOLS.SHPSLMD0
//          DD DISP=SHR, DSN=IMSTOOLS.SFOILOAD /* TOSI */
//          DD DISP=SHR, DSN=IMS.SDFSRESL
//IMSDALIB DD DISP=SHR, DSN=IMS.MDALIB
//IMS      DD DISP=SHR, DSN=IMS.DBDLIB
//DFSURCDS DD DISP=SHR, DSN=USER.LG001.DFSURCDS
//HPSGCTL  DD DSN=USER.LG001.HPSGCTL, DISP=(NEW, CATLG),
//          UNIT=SYSALLDA, SPACE=(TRK, (1, 1))
//HPSIN    DD *
(REORG)
IMSCMD=YES, TOSI
TOSIXCFGRP=REORG
DBSHARE=YES
IC=YES
STARTDB=YES
DISPOLDDS=DELETE
WORKHLQ=USER.LG001
(PREFIXRES)
ALLOWLC=NO
ALLOWLP=YES
/*
```

Figure 106. JCL for the Pre-reorganization utility (reorganizing a database in a logical group)

The DFSURCDS DD statement specifies the control data set that is created in the previous IMS Database Prereorganization utility job.

The Pre-reorganization utility creates a control data set (HPSGCTL). This data set is used by the subsequent Smart Reorg utility job, the IPR DB Scan utility job, and the Post-reorganization utility job.

In the HPSIN data set, the WORKHLQ control statement specifies the high-level qualifier for the result data sets. For more information about the result data sets, see [“Result data sets” on page 296](#).

## Smart Reorg utility job

The following figure shows example JCL to run the Smart Reorg utility to reorganize the SAMPDB02 database.

The DBD operand of EXEC PARM specifies SAMPDB02 to reorganize the SAMPDB02 database.

```
//RGEREORG EXEC PGM=HPSGMAIN, PARM=' DBD=SAMPDB02, DBRC=Y'
//STEPLIB DD DISP=SHR, DSN=IMSTOOLS.SHPSLMD0
//          DD DISP=SHR, DSN=IMSTOOLS.SIIULMOD /* IB */
//          DD DISP=SHR, DSN=IMS.SDFSRESL
//          DD DISP=SHR, DSN=USER.PGMLIB
//IMSDALIB DD DISP=SHR, DSN=IMS.MDALIB
//DFSRESLB DD DISP=SHR, DSN=IMS.SDFSRESL
//IMS      DD DISP=SHR, DSN=IMS.DBDLIB
//HPSGCTL  DD DISP=SHR, DSN=USER.LG001.HPSGCTL
//DFSURWF1 DD DSN=USER.DFSURWF1.SAMPDB02, DISP=(NEW, CATLG),
//          UNIT=SYSALLDA, SPACE=(CYL, (100, 100)), DCB=(RECFM=VB, LRECL=900)
//HPSIN    DD *
(REORG)
SPACEALLOC=YES
/*
```

Figure 107. JCL for the Smart Reorg utility (reorganizing a database in a logical group)

The HPSGCTL DD statement specifies the control data set that is created in the previous Pre-reorganization utility job.

During the job, the Smart Reorg utility performs the following actions:

- Creates shadow database data sets by unloading, reloading, and building indexes.



- Writes processing results in the result data set.
- Writes information about logical relationships in the DFSURWF1 data set.

For more information about the control statements that can be specified for the Smart Reorg utility job that runs after a Pre-reorganization utility job, see [“Control statement considerations”](#) on page 325.

## IPR DB Scan utility job

The following figure shows example JCL to run the IPR DB Scan utility to scan the SAMPDB01 database.

The DBS control statement specifies SAMPDB01 to scan the SAMPDB01 database.

```
//RGESCAN EXEC PGM=HPSCMAIN, PARM=' FUNC=SN, DBRC=Y'
//STEPLIB DD DISP=SHR, DSN=IMSTOOLS.SHPSLMD0
//          DD DISP=SHR, DSN=IMS.SDFSRESL
//          DD DISP=SHR, DSN=USER.PGMLIB
//IMSDALIB DD DISP=SHR, DSN=IMS.MDALIB
//DFSRESLB DD DISP=SHR, DSN=IMS.SDFSRESL
//IMS      DD DISP=SHR, DSN=IMS.DBDLIB
//HPSGCTL  DD DISP=SHR, DSN=USER.LG001.HPSGCTL
//HPSOUT   DD SYSOUT=A
//DFSURWF1 DD DSN=USER.DFSURWF1.SAMPDB01, DISP=(NEW, CATLG),
//          UNIT=SYSALLDA, SPACE=(CYL, (100, 100)), DCB=(RECFM=VB, LRECL=900)
//HPSIN    DD *
//          DBS=SAMPDB01
//          LOGREL=YES
//          OUTREC=YES
/*
```

Figure 108. JCL for the IPR DB Scan utility (reorganizing a database in a logical group)

The HPSGCTL DD statement specifies the control data set that is created in the previous Pre-reorganization utility job.

In this example, the DFSURCDS DD statement is not coded because the IPR DB Scan utility allocates the data set dynamically.

During the job, the IPR DB Scan utility performs the following actions:

- Writes processing results in the result data set.
- Writes information about logical relationships in the DFSURWF1 data set.

## Post-reorganization utility job

The following figure shows example JCL to run the Post-reorganization utility.

```
//RGEPOST EXEC PGM=HPSCMAIN, PARM=' FUNC=PO'
//STEPLIB DD DISP=SHR, DSN=IMSTOOLS.SHPSLMD0
//          DD DISP=SHR, DSN=IMSTOOLS.SFOILOAD /* TOSI */
//          DD DISP=SHR, DSN=IMS.SDFSRESL
//IMSDALIB DD DISP=SHR, DSN=IMS.MDALIB
//DFSRESLB DD DISP=SHR, DSN=IMS.SDFSRESL
//IMS      DD DISP=SHR, DSN=IMS.DBDLIB
//HPSGCTL  DD DISP=SHR, DSN=USER.LG001.HPSGCTL
//ICEIN    DD *
//          GLOBAL
//          HDPC=Y,
//          ICHLQ=IMSICA,
//          UNIT=SYSALLDA,
//          SPACE=(CYL, 100, 100)
/*
```

Figure 109. JCL for the Post-reorganization utility (reorganizing a database in a logical group)

The HPSGCTL DD statement specifies the control data set that is created in the previous Pre-reorganization utility job.

In this example, the DD statements for the DFSURCDS data set, the DFSURWF1 data sets, and the results data sets are not coded. These data sets are allocated dynamically by the Post-reorganization utility.

By running this job, the Post-reorganization utility performs the following actions:

- Issues /DBR commands before swapping the data set names because IMSCMD=YES,TOSI and DBSHARE=YES were specified in Pre-reorganization utility JCL.
- Invokes the IMS HP Image Copy utility after prefix resolution and update processing because IC=YES was specified in Pre-reorganization utility JCL. The IMS HP Image Copy utility invokes the HD Pointer Checker utility because HDPC=Y is specified in the ICEIN data set of Post-reorganization utility JCL.
- Deletes the original input database data sets after creating image copies because DISPOLDDS=DELETE was specified in Pre-reorganization utility JCL.
- Issues /STA commands after deleting the original input database data sets because STARTDB=YES was specified in Pre-reorganization utility JCL.

## Example 2: Reorganizing all databases in a logical group

This example provides the JCL streams for reorganizing all databases that belong to a logical group.

In this example, the following conditions are assumed:

- Five databases (SAMPDB01, SAMPDB02, SAMPDB03, SAMPDB04, and SAMPDB05) compose a logical group.
- The databases have logical relationships between each other and between their related index databases. The five databases are to be reorganized.
- Various types of logical relationships are defined in the logical group.

In this example, to reorganize the databases, utility jobs are run in the following order:

1. [“IMS Database Prereorganization utility job \(DFSURPRO\)” on page 330](#)
2. [“Pre-reorganization utility job” on page 330](#)
3. [“Smart Reorg utility jobs” on page 331](#)
4. [“Post-reorganization utility job” on page 332](#)

### IMS Database Prereorganization utility job (DFSURPRO)

The following figure shows example JCL to run the IMS Database Prereorganization utility (DFSURPRO).

The DBR control statement specifies the five databases (SAMPDB01 - SAMPDB05) to be reorganized.

```
//PREREORG EXEC PGM=DFSRR00,
//          PARM='ULU,DFSURPRO,,,,,,,,,,,,,Y,N'
//STEPLIB DD DISP=SHR,DSN=IMS.SDFSRESL
//IMSDALIB DD DISP=SHR,DSN=IMS.MDALIB
//SDFSRESLB DD DISP=SHR,DSN=IMS.SDFSRESL
//IMS DD DISP=SHR,DSN=IMS.DBDLIB
//SYSPRINT DD SYSOUT=A
//DFSURCDS DD DSN=USER.LG002.DFSURCDS,DISP=(NEW,CATLG),
//          UNIT=SYSALLDA,SPACE=(TRK,(1,1)),DCB=BLKSIZE=1600
//SYSIN DD *
DBR=SAMPDB01,SAMPDB02,SAMPDB03,SAMPDB04,SAMPDB05
OPTIONS=(NOPUNCH,STAT,SUMM)
/*
```

Figure 110. JCL for the IMS Database Prereorganization utility (reorganizing all databases in a logical group)

The DFSURPRO utility creates a control data set (DFSURCDS). This data set will be used by the subsequent Pre-reorganization utility job, the Smart Reorg utility job, and the Post-reorganization utility job.

### Pre-reorganization utility job

The following figure shows example JCL to run the Pre-reorganization utility.

IMSCMD=YES,TOSI and DBSHARE=YES are specified to request that the Pre-reorganization utility issue /DBD commands.

```

//RGEPRE EXEC PGM=HPSCMAIN, PARM=' FUNC=PR'
//STEPLIB DD DISP=SHR, DSN=IMSTOOLS.SHPSLMD0
// DD DISP=SHR, DSN=IMSTOOLS.SFOILOAD /* TOSI */
// DD DISP=SHR, DSN=IMS.SDFSRESL
//IMSDALIB DD DISP=SHR, DSN=IMS.MDALIB
//IMS DD DISP=SHR, DSN=IMS.DBDLIB
//DFSURCDS DD DISP=SHR, DSN=USER.LG002.DFSURCDS
//HPSGCTL DD DSN=USER.LG002.HPSGCTL, DISP=(NEW,CATLG),
// UNIT=SYSALLDA, SPACE=(TRK, (1,1))
//HPSIN DD *
(REORG)
IMSCMD=YES, TOSI
TOSIXCFGRP=REORG
DBSHARE=YES
IC=YES
INDEXBLD=YES
STARTDB=YES
DISPOLDDS=DELETE
WORKHLQ=USER.LG002
(PREFIXRES)
ALLOWLC=NO
ALLOWLP=YES
/*

```

Figure 111. JCL for the Pre-reorganization utility (reorganizing all databases in a logical group)

The DFSURCDS DD statement specifies the control data set that is created in the previous IMS Database Pre-reorganization utility job.

The Pre-reorganization utility creates a control data set (HPSGCTL). This data set is used by the subsequent Smart Reorg utility job and the Post-reorganization utility job.

In the HPSIN data set, the WORKHLQ control statement specifies the high-level qualifier for the result data sets. For more information about the result data sets, see [“Result data sets” on page 296](#).

## Smart Reorg utility jobs

The following figure shows an example of the cataloged procedure for the Smart Reorg utility.

In this example, this cataloged procedure is used for reorganizing the five databases.

```

//REORG PROC
//RGE EXEC PGM=HPSGMAIN, PARM=' DBD=&DBD, DBRC=Y'
//STEPLIB DD DISP=SHR, DSN=IMSTOOLS.SHPSLMD0
// DD DISP=SHR, DSN=IMSTOOLS.SIIULMOD /* IB */
// DD DISP=SHR, DSN=IMS.SDFSRESL
// DD DISP=SHR, DSN=USER.PGMLIB
//IMSDALIB DD DISP=SHR, DSN=IMS.MDALIB
//DFSRESLB DD DISP=SHR, DSN=IMS.SDFSRESL
//IMS DD DISP=SHR, DSN=IMS.DBDLIB
//HPSGCTL DD DISP=SHR, DSN=USER.LG002.HPSGCTL
//HPSIN DD DISP=SHR, DSN=USER.HPSIN
// PEND
// *

```

Figure 112. Sample cataloged procedure for the Smart Reorg utility (reorganizing all databases in a logical group)

The HPSGCTL DD statement specifies the control data set that is created in the previous Pre-reorganization utility job.

The USER.HPSIN data set that is specified on the HPSIN DD statement contains the following control statement:

```

(REORG)
SPACEALLOC=YES

```

For more information about the control statements that can be specified for the Smart Reorg utility job that runs after a Pre-reorganization utility job, see [“Control statement considerations” on page 325](#).

The following figure shows example JCL to run the Smart Reorg utility to reorganize the five databases by using the cataloged procedure REORG.

In this example:

- The DBD parameter in each job step specifies the name of the database to be reorganized.
- Each job step specifies a DFSURWF1 data set as an output data set for resolving logical relationships.

```

//*-----*
//* RUN SMART REORG UTILITY FOR SAMPDB01                *
//*-----*
//REORG1 EXEC REORG,DBD=SAMPDB01
//DFSURWF1 DD DSN=USER.DFSURWF1.SAMPDB01,DISP=(NEW,CATLG),
//          UNIT=SYSALLDA,SPACE=(CYL,(100,100)),
//          DCB=(RECFM=VB,LRECL=900)
//*
//*-----*
//* RUN SMART REORG UTILITY FOR SAMPDB02                *
//*-----*
//REORG2 EXEC REORG,DBD=SAMPDB02
//DFSURWF1 DD DSN=USER.DFSURWF1.SAMPDB02,DISP=(NEW,CATLG),
//          UNIT=SYSALLDA,SPACE=(CYL,(50,50)),
//          DCB=(RECFM=VB,LRECL=900)
//*
//*-----*
//* RUN SMART REORG UTILITY FOR SAMPDB03                *
//*-----*
//REORG3 EXEC REORG,DBD=SAMPDB03
//DFSURWF1 DD DSN=USER.DFSURWF1.SAMPDB03,DISP=(NEW,CATLG),
//          UNIT=SYSALLDA,SPACE=(CYL,(200,200)),
//          DCB=(RECFM=VB,LRECL=900)
//*
//*-----*
//* RUN SMART REORG UTILITY FOR SAMPDB04                *
//*-----*
//REORG4 EXEC REORG,DBD=SAMPDB04
//DFSURWF1 DD DSN=USER.DFSURWF1.SAMPDB04,DISP=(NEW,CATLG),
//          UNIT=SYSALLDA,SPACE=(CYL,(100,100)),
//          DCB=(RECFM=VB,LRECL=900)
//*
//*-----*
//* RUN SMART REORG UTILITY FOR SAMPDB05                *
//*-----*
//REORG5 EXEC REORG,DBD=SAMPDB05
//DFSURWF1 DD DSN=USER.DFSURWF1.SAMPDB05,DISP=(NEW,CATLG),
//          UNIT=SYSALLDA,SPACE=(CYL,(150,150)),
//          DCB=(RECFM=VB,LRECL=900)
//*

```

Figure 113. JCL for the Smart Reorg utility (reorganizing all databases in a logical group)

**Tip:** By making each job step a separate job, you can reorganize the databases in parallel.

## Post-reorganization utility job

The following figure shows example JCL to run the Post-reorganization utility.

```

//RGEPOST EXEC PGM=HPSCMAIN,PARM='FUNC=PO'
//STEPLIB DD DISP=SHR,DSN=IMSTOOLS.SHPSLMD0
//        DD DISP=SHR,DSN=IMSTOOLS.SFOILOAD /* TOSI */
//        DD DISP=SHR,DSN=IMS.SDFSRESL
//IMSDALIB DD DISP=SHR,DSN=IMS.MDALIB
//DFSRESLB DD DISP=SHR,DSN=IMS.SDFSRESL
//IMS DD DISP=SHR,DSN=IMS.DBDLIB
//HPSGCTL DD DISP=SHR,DSN=USER.LG002.HPSGCTL
//ICEIN DD *
//GLOBAL HDPC=Y,
//        ICHLQ=IMSICA,
//        UNIT=SYSALLDA,
//        SPACE=(CYL,100,100)
//*

```

Figure 114. JCL for the Post-reorganization utility (reorganizing all databases in a logical group)

The HPSGCTL DD statement specifies the control data set that is created in the previous Pre-reorganization utility job.

In this example, the DD statements for the DFSURCDS data set, the DFSURWF1 data sets, and the results data sets are not coded. Those data sets are allocated dynamically by the Post-reorganization utility.

By running this job, the Post-reorganization utility performs the following actions:

- Issues /DBR commands before swapping the data set names because IMSCMD=YES,TOSI and DBSHARE=YES were specified in Pre-reorganization utility JCL.
- Invokes the IMS HP Image Copy utility after the prefix resolution and update processing because IC=YES was specified in Pre-reorganization utility JCL. The IMS HP Image Copy utility invokes the HD Pointer Checker utility because HDPC=Y is specified in the ICEIN data set of Post-reorganization utility JCL.
- Deletes the original input database data sets after creating image copies because DISPOLDDS=DELETE was specified in Pre-reorganization utility JCL.
- Issues /STA commands after deleting the original input database data sets because STARTDB=YES was specified in Pre-reorganization utility JCL.



---

## Chapter 22. Pre-reorganization utility and Post-reorganization utility reports

The Pre-reorganization utility and the Post-reorganization utility generate reports that help you understand the conditions of the databases before and after reorganization.

### Topics:

- [“Pre-reorganization utility reports” on page 335](#)
- [“Post-reorganization utility reports” on page 340](#)

---

### Pre-reorganization utility reports

The Pre-reorganization utility generates reports that help you understand the conditions of the databases before reorganization.

Subsections:

- [“Pre-reorganization utility reports” on page 335](#)
- [“Pre-reorganization utility reports in IMS Tools Knowledge Base” on page 336](#)

### Pre-reorganization utility reports

The following table lists the reports that the Pre-reorganization utility produces and the corresponding output data sets.

---

*Table 41. Reports produced by the Pre-reorganization utility*

Output data set	Report name	Description
HPSOUT	Environment	Contains the EXEC parameters that were specified for the job and the release levels of the operating system and IMS.
	Default Option Tables	Contains the contents of the System Default Option Table (HPSCOPTS) and the Installation Default Option Table (HPSCOPTI). If HPSCOPTI was used, this report contains both HPSCOPTS and HPSCOPTI. If HPSCOPTS was used, this report contains only HPSCOPTS.
	HPSIN Control Statements	Contains an echo of the control statements that you specified in the HPSIN data set. You can check the options that were activated for the job.
	List of Databases Need to be Processed report	Contains the DBD names of the databases that need to be reorganized or scanned.
	Work Data Set Information report	Contains information about the control data set and the result data sets.
HPSOUT2	DBRC Authorization Processing for Reorganization	Contains the DBRC authorization processing information.
	IMS Command Processing	Contains the IMS command processing information.

---

## Pre-reorganization utility reports in IMS Tools Knowledge Base

When Pre-reorganization utility reports are stored in the Output repository of IMS Tools KB, the report names that are defined in IMS Tools KB are used for managing the reports. The following table lists the report names that are used in IMS Tools KB.

Table 42. Pre-reorganization utility report names used in IMS Tools KB

Report name	Long title	Short title
List of Databases Need to be Processed	RGE-List of Databases Need to be Processed	RGE-Pre Reorg DB list

## HPSOUT data set (Pre-reorganization utility)

The HPSOUT data set is the primary statistics output data set that contains reports produced by the Pre-reorganization utility.

In this data set, the following reports are written in the following order:

1. Environment report that shows the EXEC parameters and the system environment.
2. Default Option Tables report for the Pre-reorganization utility.
3. HPSIN Control Statements report for the Pre-reorganization utility.
4. List of Databases Need to be Processed report that identifies the databases to be processed.
5. Work Data Set Information report that summarizes the work data set information.

## Environment report (Pre-reorganization utility)

The Environment report contains the EXEC parameters that were specified for the job and the release levels of the operating system and IMS.

The following figure is an example of the Environment report.

```
IMS DB REORG EXPERT                                PAGE:      1
5655-S35                                           11/01/2023 15.22.29

                                "ENVIRONMENT"

EXEC PARAMETERS

FUNCTION..... PRE-REORGANIZATION
IMS ID..... SYS1

SYSTEM ENVIRONMENT

OPERATING SYSTEM..... z/OS 02.04.00
STORAGE MANAGEMENT..... DFSMS/zOS 02.04.00
IMS..... IMS 15.1.0
RECON DATA SET..... IMS V15R1      (MINIMUM VERSION = 13.1)
ACCESS=SERIAL
PRODUCT VERSION..... IMS DB REORG EXPERT V4.1.0
```

Figure 115. Environment report (Pre-reorganization utility)

## Default Option Tables report (Pre-reorganization utility)

The Default Option Tables report contains the contents of the System Default Option Table (HPSCOPTS) and the Installation Default Option Table (HPSCOPTI).

If HPSCOPTI was used in the job, this report contains both HPSCOPTS and HPSCOPTI. If HPSCOPTS was used in the job, this report contains only HPSCOPTS.

The following figure is an example of the Default Option Tables report when HPSCOPTI was used in the job.



"DEFAULT OPTION TABLES"

SYSTEM DEFAULT: HPSCOPTS IN RGE410.SHPSLMD0  
INSTALLATION DEFAULT: HPSCOPTI IN TEMPDS.RGE410.OPTLIB

KEYWORD	SYSTEM DEFAULT	INSTALLATION DEFAULT
CONDREORG	NO	NO
DECODEDBD	(NO,NO)	(NO,NO)
DECODESX	(NO,NO)	(NO,NO)
DISPOLDDS	TEMPNAME	DELETE
HPIO	N/A	N/A
ILDSBLD	(YES,DSPR)	(YES,DSPR)
ITKBDATA	*NO	*NO
ITKBLOAD	*NO	*NO
ITKBSRVR	*NO	*NO
PIPEWAIT	0.5,OPEN	0.5,OPEN
PIPEWAIT	15,RDWR	15,RDWR
SINDEXSUF	NO	NO
STATRL	NO	NO
ZIIPMODE	NEVER	NEVER

Figure 116. Default Option Tables report when HPSCOPTI is used (Pre-reorganization utility)

The following figure is an example of the Default Option Tables report when HPSCOPTS was used in the job.

"DEFAULT OPTION TABLES"

SYSTEM DEFAULT: HPSCOPTS IN RGE410.SHPSLMD0  
INSTALLATION DEFAULT: HPSCOPTI NOT FOUND

KEYWORD	SYSTEM DEFAULT
CONDREORG	NO
DECODEDBD	(NO,NO)
DECODESX	(NO,NO)
DISPOLDDS	TEMPNAME
HPIO	N/A
ILDSBLD	(YES,DSPR)
ITKBDATA	*NO
ITKBLOAD	*NO
ITKBSRVR	*NO
PIPEWAIT	0.5,OPEN
PIPEWAIT	15,RDWR
SINDEXSUF	NO
STATRL	NO
ZIIPMODE	NEVER

Figure 117. Default Option Tables report when HPSCOPTS is used (Pre-reorganization utility)

**Related concepts**

**Setting installation default options**

You can change the default values for some options by creating an Installation Default Option Table (HPSCOPTI) for your site.

**HPSIN Control Statements report (Pre-reorganization utility)**

The HPSIN Control Statements report contains an echo of the control statements that you specified in the HPSIN data set. You can check the options that were activated for the Pre-reorganization utility job.

The following figure is an example of the HPSIN Control Statements report.

Note that all blank lines in the HPSIN data set are removed.

"HPSIN CONTROL STATEMENTS"

```

0.....1.....2.....3.....4.....5.....6.....7.....8
1234567890123456789012345678901234567890123456789012345678901234567890
(REORG)
  ITKBSRVR=FPQSVR00
  DBRCAUTHCMD=YES
  IC=YES
  DISPOLDDS=DELETE
  WORKHLQ=USER.LG001
IMS DB REORG EXPERT
5655-S35

```

"HPSIN CONTROL STATEMENTS"

"RUN TIME OPTIONS FOR PRE-REORGANIZATION UTILITY & POST-REORGANIZATION UTILITY"

OPTIONS FOR REORG FUNCTION:

KEYWORD	VALUE
ADDBGRP	N/A (NOTE: THIS OPTION IS IGNORED WHEN ADXCFGRP=*NO)
ADXCFGRP	*NO
AUTHFAIL	ABORT
DALUNIT	SYSALLDA
DBRCAUTHCMD	YES
DBSHARE	NO
DELOLDDS	N/A (NOTE: DISPOLDDS DETERMINES THE DISPOSITION OF OLD DATA SETS)
DISPOLDDS	DELETE
HPIO	N/A (NOTE: THIS OPTION IS NOT SPECIFIED FOR DRIVER)
IC	YES
ICNEEDED	N/A (NOTE: THIS OPTION IS IGNORED WHEN IC=YES)
IMSCMD	NO
IMSCMDOPT	N/A (NOTE: THIS OPTION IS IGNORED UNLESS IMSCMD=YES,TOSI)
INDEXBLD	NO
ITKBSRVR	FPQSVR00
ITKBLOAD	*NO
ITKBDATA	*NO
LASTAUTHFLAG	OFF
NAMESWAPFAIL	ABORT
STARTDB	N/A (NOTE: THIS OPTION IS IGNORED UNLESS IMSCMD=YES,TOSI)
TOSITASK	N/A (NOTE: THIS OPTION IS IGNORED UNLESS IMSCMD=YES,TOSI)
TOSITEST	N/A (NOTE: THIS OPTION IS IGNORED UNLESS IMSCMD=YES,TOSI)
TOSIWAIT	N/A (NOTE: THIS OPTION IS IGNORED UNLESS IMSCMD=YES,TOSI)
TOSIXCFGRP	N/A (NOTE: THIS OPTION IS NOT SPECIFIED)
WORKHLQ	USER.LG001
WORKUNIT	SYSALLDA
WORKVOL	N/A (NOTE: THIS OPTION IS NOT SPECIFIED)

Figure 118. HPSIN Control Statements report (Pre-reorganization utility)

### List of Databases Need to be Processed report (Pre-reorganization utility)

The List of Databases Need to be Processed report contains the DBD names of the databases that need to be reorganized or scanned in the subsequent jobs.

The following figure is an example of the List of Databases Need to be Processed report.

"LIST OF DATABASES NEED TO BE PROCESSED"

```
DATABASES NEED TO BE REORGANIZED:
  DBD NAME..... HDAMDB01
  SECONDARY INDEX..... HDAMX01

  DBD NAME..... HIDAMDB1
  PRIMARY INDEX..... HIDAMIX1

DATABASES NEED TO BE SCANNED:
  DBD NAME..... HDAMDB02

  DBD NAME..... HIDAMDB2
  PRIMARY INDEX..... HIDAMIX2
```

Figure 119. List of Databases Need to be Processed report (Pre-reorganization utility)

## Work Data Set Information report (Pre-reorganization utility)

The Work Data Set Information report contains information about the control data set and the result data sets.

Information about the following data sets is recorded in this report:

- The control data set (HPSGCTL) that is created in the Pre-reorganization utility job.
- The result data sets (HPSGRSLT) that are allocated by the Pre-reorganization utility job. Subsequent Smart Reorg utility jobs or IPR DB Scan utility jobs write data into these data sets.

These data sets are used in the subsequent Post-reorganization utility job.

The following figure is an example of the Work Data Set Information report.

"WORK DATA SET INFORMATION"

```
DD NAME  DATA SET NAME
-----
HPSGCTL  USER.LG001.HPSGCTL
HPSGRSLT USER.LG001.RSL.HDAMDB01
HPSGRSLT USER.LG001.RSL.HIDAMDB1
HPSGRSLT USER.LG001.RSL.HDAMDB02
HPSGRSLT USER.LG001.RSL.HIDAMDB2
```

Figure 120. Work Data Set Information report (Pre-reorganization utility)

## HPSOUT2 data set (Pre-reorganization utility)

The HPSOUT2 data set is a secondary output data set that contains the reports that are produced by the Pre-reorganization utility.

In this data set, the following reports are written in the following order:

1. DBRC Authorization Processing for Reorganization report
2. IMS Command Processing report

## DBRC Authorization Processing for Reorganization report (Pre-reorganization utility)

The DBRC Authorization Processing for Reorganization report contains the DBRC authorization processing information.

The following figure shows the report that is produced when DBRC commands are issued by the Pre-reorganization utility during DBRC authorization processing for reorganization.

```

CHANGE.DB      DBD(ITHIDM02) NOAUTH
DSP0203I      COMMAND COMPLETED WITH CONDITION CODE 00
DSP0220I      COMMAND COMPLETION TIME 23.183 10:24:36.5
DSP0211I      COMMAND PROCESSING COMPLETE
DSP0211I      HIGHEST CONDITION CODE = 00
CHANGE.DB      DBD(ITHIDM01) NOAUTH
DSP0203I      COMMAND COMPLETED WITH CONDITION CODE 00
DSP0220I      COMMAND COMPLETION TIME 23.183 10:24:36.5
DSP0211I      COMMAND PROCESSING COMPLETE
DSP0211I      HIGHEST CONDITION CODE = 00
CHANGE.DB      DBD(ITHIDM04) NOAUTH
DSP0203I      COMMAND COMPLETED WITH CONDITION CODE 00
DSP0220I      COMMAND COMPLETION TIME 23.183 10:24:36.5
DSP0211I      COMMAND PROCESSING COMPLETE
DSP0211I      HIGHEST CONDITION CODE = 00
CHANGE.DB      DBD(ITHIDM03) NOAUTH
DSP0203I      COMMAND COMPLETED WITH CONDITION CODE 00
DSP0220I      COMMAND COMPLETION TIME 23.183 10:24:36.5
DSP0211I      COMMAND PROCESSING COMPLETE
DSP0211I      HIGHEST CONDITION CODE = 00
    
```

Figure 121. DBRC Authorization Processing for Reorganization report (Pre-reorganization utility)

## IMS Command Processing report (Pre-reorganization utility)

The IMS Command Processing report contains the IMS command processing information.

The following figure shows the report that is produced when IMSCMD=YES,TOSI is specified and one or more IMS commands are issued to the IMS online subsystems through the IMS Tools Online System Interface.

IMS COMMAND: /DBR DB DBNAME LOCAL NOFE0V  
TOSI WAIT: 300 SEC

IMSID	DBNAME	REQ	RES	RC	RSN	STATUS
IMA1	ITHIDM02	Y	Y	00	00	DFS0488I RC=00
	ITHIDM01	Y	Y	00	00	DFS0488I RC=00
	ITHIDM04	Y	Y	00	00	DFS0488I RC=00
	ITHIDM03	Y	Y	00	00	DFS0488I RC=00

Figure 122. IMS Command Processing report (Pre-reorganization utility)

## Post-reorganization utility reports

The Post-reorganization utility generates reports that help you understand the condition of the databases after reorganization.

The reports that are produced by IMS HP Prefix Resolution, IMS HP Image Copy, and IMS HP Pointer Checker can be stored in the Output repository of IMS Tools KB. Reports that are produced by the Post-reorganization utility cannot be stored in the Output repository of IMS Tools KB.

Subsections:

- [“Post-reorganization utility reports” on page 340](#)
- [“Reports from the optional tasks” on page 341](#)

### Post-reorganization utility reports

The following table lists the reports that the Post-reorganization utility produces and the corresponding output data sets.

Table 43. Reports produced by the Post-reorganization utility

Output data set	Report name	Description
HPSOUT	Environment	Contains the EXEC parameters that were specified for the job, the release level of the operating system and IMS, and a list of databases that were processed.

Table 43. Reports produced by the Post-reorganization utility (continued)

Output data set	Report name	Description
HPSOUT2	DBRC Authorization Processing for Name Swapping	Contains the DBRC authorization processing information for name swapping.
	Result of Name Swapping	Contains the output from IDCAMS commands that were issued during data set name swapping.
	DBRC Notification Processing	Contains the DBRC notification processing information.
	IDCAMS Command Stream for Recovery from Name Swap Error	Contains the IDCAMS command stream that is generated by the Post-reorganization utility.
	Result of Old Data Sets Deletion	Contains the result of deleting the old original data sets by the IDCAMS command.
	DBRC processing for restoring authorization flags	Contains the DBRC processing information for restoring authorization flags.
	IMS Command Processing	Contains the IMS command processing information.

## Reports from the optional tasks

Various reports are produced by the optional tasks.

### Reports produced by IMS HP Prefix Resolution

When the prefix resolution task is called during a Post-reorganization utility job, IMS HP Prefix Resolution generates reports about the task.

The following reports are produced by IMS HP Prefix Resolution:

- FABYIN Control Statements
- Orphan Records
- Prefix Update Processing Summary
- Diagnostics and Summary
- Statistics

For details about each report, see the *IMS High Performance Prefix Resolution User's Guide*.

### Reports produced by IMS HP Image Copy

When the image copy task is called during a Post-reorganization utility job, IMS HP Image Copy generates reports about the task.

The following reports are produced by IMS HP Image Copy:

- ICEIN Statements report (in ICEPRINT DD)
- Database Data Set Image Copy Utility report (in DFSPRINT DD)
- Image Copy Dump Process report (in ICEPRNT DD)

For the details about each report, see the *IMS High Performance Image Copy User's Guide*.

### Reports produced by IMS HP Pointer Checker

When HASH pointer checking is called during a Post-reorganization utility job, IMS HP Pointer Checker generates database statistics reports with separator pages.

To generate the following reports, specify the relevant suboption for the HDPC option:

- Bit Map Display report (when HDPC=(YES,BITMAP) is specified)

- Free Space Map report (when HDPC=(YES,FSEMAP) is specified)
- Maximum Free Space Distribution report (when HDPC=(YES,MAXFSD) is specified)

For details about each report, see the *IMS High Performance Image Copy User's Guide* and the *IMS High Performance Pointer Checker User's Guide*.

## HPSOUT data set (Post-reorganization utility)

The HPSOUT data set is the primary statistics output data set that contains the Environment report that is produced by the Post-reorganization utility.

### Environment report (Post-reorganization utility)

The Environment report contains the EXEC parameters that were specified for the job, the release level of the operating system and IMS, and a list of databases that were processed.

The following figure is an example of the Environment report.

```

IMS DB REORG EXPERT                                PAGE:      1
5655-S35                                           11/01/2023 15.24.48

                                "ENVIRONMENT"

EXEC PARAMETERS

FUNCTION..... POST-REORGANIZATION
IMS ID..... SYS1
GLOBAL SERVICE GROUP NAME..... (SYSTEM DEFAULT)
ACTIVATE IRLM FOR NATIVE DL/I CALLS... (SYSTEM DEFAULT)
MAKE ADDRESS SPACE SWAPPABLE..... NO

SYSTEM ENVIRONMENT

OPERATING SYSTEM..... z/OS 02.04.00
STORAGE MANAGEMENT..... DFSMS/zOS 02.04.00
IMS..... IMS 15.1.0
RECON DATA SET..... IMS V15R1 (MINIMUM VERSION = 13.1)
ACCESS=SERIAL
PRODUCT VERSION..... IMS DB REORG EXPERT V4.1.0

DATABASES
DBD NAME  DB-ORG  ACCESS  PROCESS
-----  -
HDAMDB01  HDAM    OSAM    REORG
HDAMX01   INDEX(S)  VSAM    BUILD
HIDAMDB1  HIDAM    OSAM    REORG
HIDAMIX1  INDEX(P)  VSAM    REORG
HDAMDB02  HDAM    OSAM    SCAN
HIDAMDB2  HIDAM    OSAM    SCAN
HIDAMIX2  INDEX(P)  VSAM    SCAN

```

Figure 123. Environment report (Post-reorganization utility)

## HPSOUT2 data set (Post-reorganization utility)

The HPSOUT2 data set is the secondary output data set that contains the reports that are produced by the Post-reorganization utility.

In this data set, the following reports are written in the following order:

1. DBRC Authorization Processing for Name Swapping report
2. Result of Name Swapping report
3. DBRC Notification Processing report
4. IDCAMS Command Stream for Recovery from Name Swap Error report
5. IMS Command Processing report

If you specify DELOLDDS=YES to delete the old original data sets, the Result of Old Data Sets Deletion report is produced.

If one or more errors were detected in reorganization processing and if the Post-reorganization utility tried to restore the authorization flags in the RECON data sets, the DBRC Processing for Restoring Authorization Flags report is also produced.

## DBRC Authorization Processing for Name Swapping report (Post-reorganization utility)

The DBRC Authorization Processing for Name Swapping report contains the DBRC authorization processing information for name swapping.

The following figure shows the report that is produced when DBRC commands are issued by the Post-reorganization utility during DBRC authorization processing for name swapping.

```
IMS DB REORG EXPERT                "DBRC AUTHORIZATION PROCESSING FOR NAME SWAPPING"                PAGE: 1
5655-S35                                                                    07/01/2023 20.07.14

CHANGE.DB      DBD(ITHIDM02) NOAUTH
DSP0203I      COMMAND COMPLETED WITH CONDITION CODE 00
DSP0220I      COMMAND COMPLETION TIME 23.183 20:07:13.9
DSP0211I      COMMAND PROCESSING COMPLETE
DSP0211I      HIGHEST CONDITION CODE = 00
CHANGE.DB      DBD(ITHIDM01) NOAUTH
DSP0203I      COMMAND COMPLETED WITH CONDITION CODE 00
DSP0220I      COMMAND COMPLETION TIME 23.183 20:07:13.9
DSP0211I      COMMAND PROCESSING COMPLETE
DSP0211I      HIGHEST CONDITION CODE = 00
CHANGE.DB      DBD(ITHIDM04) NOAUTH
DSP0203I      COMMAND COMPLETED WITH CONDITION CODE 00
DSP0220I      COMMAND COMPLETION TIME 23.183 20:07:13.9
DSP0211I      COMMAND PROCESSING COMPLETE
DSP0211I      HIGHEST CONDITION CODE = 00
CHANGE.DB      DBD(ITHIDM03) NOAUTH
DSP0203I      COMMAND COMPLETED WITH CONDITION CODE 00
DSP0220I      COMMAND COMPLETION TIME 23.183 20:07:13.9
DSP0211I      COMMAND PROCESSING COMPLETE
DSP0211I      HIGHEST CONDITION CODE = 00
```

Figure 124. DBRC Authorization Processing for Name Swapping report (Post-reorganization utility)

## Result of Name Swapping report (Post-reorganization utility)

The Result of Name Swapping report contains the output from IDCAMS commands that were issued during data set name swapping.

If any error occurs while swapping the data set names, the output from the IDCAMS commands that are issued in follow-up processing is shown in the subsequent pages of this report. The actions performed in follow-up processing depend on the NAMESWAPFAIL control statement specification.

```
IF MAXCC EQ 0 THEN -
DO
  ALTER TESTDB. IMS11A. ITHIDM02. DBDS1 -
  NEWNAME( TESTDB. IMS11A. ITHIDM02. DBDS1. T )
IDC0531I ENTRY TESTDB. IMS11A. ITHIDM02. DBDS1 ALTERED
IDC0001I FUNCTION COMPLETED, HIGHEST CONDITION CODE WAS 0
  ALTER TESTDB. IMS11A. ITHIDM02. DBDS1. DATA -
  NEWNAME( TESTDB. IMS11A. ITHIDM02. DBDS1. DATA. T )
IDC0531I ENTRY TESTDB. IMS11A. ITHIDM02. DBDS1. DATA ALTERED
IDC0001I FUNCTION COMPLETED, HIGHEST CONDITION CODE WAS 0
END
```

...

```
IF MAXCC EQ 0 THEN -
IMS DB REORG EXPERT
5655-S35
```

```
DO
  ALTER TESTDB. IMS11A. ITHIDM02. DBDS1. Z -
  NEWNAME( TESTDB. IMS11A. ITHIDM02. DBDS1 )
IDC0531I ENTRY TESTDB. IMS11A. ITHIDM02. DBDS1. Z ALTERED
IDC0001I FUNCTION COMPLETED, HIGHEST CONDITION CODE WAS 0
  ALTER TESTDB. IMS11A. ITHIDM02. DBDS1. DATA. Z -
  NEWNAME( TESTDB. IMS11A. ITHIDM02. DBDS1. DATA )
IDC0531I ENTRY TESTDB. IMS11A. ITHIDM02. DBDS1. DATA. Z ALTERED
IDC0001I FUNCTION COMPLETED, HIGHEST CONDITION CODE WAS 0
END
```

...

```
IDC0002I IDCAMS PROCESSING COMPLETE. MAXIMUM CONDITION CODE WAS 0
```

Figure 125. Result of Name Swapping report (Post-reorganization utility)

### Related reference

#### NAMESWAPFAIL control statement

Specifies the action which the Smart Reorg utility takes when the IDCAMS program returns an error during name swapping.

### DBRC Notification Processing report (Post-reorganization utility)

The DBRC Notification Processing report contains the DBRC notification processing information.

The following figure shows the report that is produced when DBRC commands are issued by the Post-reorganization utility during DBRC notification processing.



```

IMS DB REORG EXPERT          "DBRC NOTIFICATION PROCESSING"          PAGE:      1
5655-S35                    07/01/2023  20.32.39

  NOTIFY.REORG DBD(ITHIDM02) DDN(ITHIDM02) USID(0000000001)      -
    RUNTIME('2023.183 20:32:23.3 +09:00')
DSP0203I  COMMAND COMPLETED WITH CONDITION CODE 00
DSP0220I  COMMAND COMPLETION TIME 23.183 20:32:35.7
IMS DB REORG EXPERT          "DBRC NOTIFICATION PROCESSING"          PAGE:      2
5655-S35                    07/01/2023  20.32.39

...

IMS DB REORG EXPERT          "DBRC NOTIFICATION PROCESSING"          PAGE:      5
5655-S35                    07/01/2023  20.32.39

  NOTIFY.IC  DBD(ITHIDM02) DDN(ITHIDM02) USID(0000000001)  -
    RUNTIME('2023.183 20:32:26.3 +09:00')
    BATCH
    ICDSN(TEMPDS.SNFA13.IMS11A.IC1.ITHIDM02.ITHIDM02)
    FILESEQ(0001) UNIT(3390)
    VOLLIST(DBT00B)
    RECDCT(0000000003)
DSP0203I  COMMAND COMPLETED WITH CONDITION CODE 00
DSP0220I  COMMAND COMPLETION TIME 23.183 20:32:37.8
IMS DB REORG EXPERT          "DBRC NOTIFICATION PROCESSING"          PAGE:      6
5655-S35                    07/01/2023  20.32.39

...

IMS DB REORG EXPERT          "DBRC NOTIFICATION PROCESSING"          PAGE:      9
5655-S35                    07/01/2023  20.32.39

  CHANGE.DB  DBD(ITHIDM02) AUTH READOFF
DSP0203I  COMMAND COMPLETED WITH CONDITION CODE 00
DSP0220I  COMMAND COMPLETION TIME 23.183 20:32:39.0
IMS DB REORG EXPERT          "DBRC NOTIFICATION PROCESSING"          PAGE:     10
5655-S35                    07/01/2023  20.32.39

...

IMS DB REORG EXPERT          "DBRC NOTIFICATION PROCESSING"          PAGE:     13
5655-S35                    07/01/2023  20.32.39

DSP0211I  COMMAND PROCESSING COMPLETE
DSP0211I  HIGHEST CONDITION CODE = 00

```

Figure 126. DBRC Notification Processing report (Post-reorganization utility)

## IDCAMS Command Stream for Recovery from Name Swap Error report (Post-reorganization utility)

The IDCAMS Command Stream for Recovery from Name Swap Error report contains the IDCAMS command stream that is generated by the Post-reorganization utility.

If a name swapping error occurs and the automated backout processing is not performed by the Post-reorganization utility, the Post-reorganization utility generates an IDCAMS command stream. This command stream is recorded in the IDCAMS Command Stream for Recovery from Name Swap Error report and in the HPSGSWAP data sets. The HPSGSWAP data sets can be used as the SYSIN data set of the succeeding IDCAMS job after correcting the cause of the name swapping error.

The following figure shows the IDCAMS Command Stream for Recovery from Name Swap Error report.

```

/*=====*/
/*          RECOVERING SHADOW DATA SET(S)          */
/*=====*/

IF MAXCC EQ 0 THEN -
DO
  ALTER  TESTDB. IMS11A. ITHIDM02. DBDS1          -
  NEWNAME (TESTDB. IMS11A. ITHIDM02. DBDS1. Z      )
  ALTER  TESTDB. IMS11A. ITHIDM02. DBDS1. DATA    -
  NEWNAME (TESTDB. IMS11A. ITHIDM02. DBDS1. DATA. Z)
END
/*=====*/
/*          RECOVERING OLD DATA SET(S)             */
/*=====*/

IF MAXCC EQ 0 THEN -
DO
  ALTER  TESTDB. IMS11A. ITHIDM02. DBDS1. T          -
  NEWNAME (TESTDB. IMS11A. ITHIDM02. DBDS1          )
  ALTER  TESTDB. IMS11A. ITHIDM02. DBDS1. DATA. T    -
  NEWNAME (TESTDB. IMS11A. ITHIDM02. DBDS1. DATA    )
END

IF MAXCC EQ 0 THEN -
DO
  ALTER  TESTDB. IMS11A. ITHIDM01. DBDS1. T          -
  NEWNAME (TESTDB. IMS11A. ITHIDM01. DBDS1          )
  ALTER  TESTDB. IMS11A. ITHIDM01. DBDS1. DATA. T    -
  NEWNAME (TESTDB. IMS11A. ITHIDM01. DBDS1. DATA    )
  ALTER  TESTDB. IMS11A. ITHIDM01. DBDS1. INDEX. T    -
  NEWNAME (TESTDB. IMS11A. ITHIDM01. DBDS1. INDEX    )
END

IF MAXCC EQ 0 THEN -
DO
  ALTER  TESTDB. IMS11A. ITHIDM04. DBDS1. T          -
  NEWNAME (TESTDB. IMS11A. ITHIDM04. DBDS1          )
  ALTER  TESTDB. IMS11A. ITHIDM04. DBDS1. DATA. T    -
  NEWNAME (TESTDB. IMS11A. ITHIDM04. DBDS1. DATA    )
END

IF MAXCC EQ 0 THEN -
DO
  ALTER  TESTDB. IMS11A. ITHIDM03. DBDS1. T          -
  NEWNAME (TESTDB. IMS11A. ITHIDM03. DBDS1          )
  ALTER  TESTDB. IMS11A. ITHIDM03. DBDS1. DATA. T    -
  NEWNAME (TESTDB. IMS11A. ITHIDM03. DBDS1. DATA    )
  ALTER  TESTDB. IMS11A. ITHIDM03. DBDS1. INDEX. T    -
  NEWNAME (TESTDB. IMS11A. ITHIDM03. DBDS1. INDEX    )
END

```

Figure 127. IDCAMS Command Stream for Recovery from Name Swap Error report (Post-reorganization utility)

## Result of Old Data Sets Deletion report (Post-reorganization utility)

The Result of Old Data Sets Deletion report contains results of deleting the old original data sets by the IDCAMS command.

The following figure shows the report that is produced by the Post-reorganization utility when DISPOLDDS=DELETE was specified in Pre-reorganization utility JCL.

The original data sets are renamed with a temporary name with suffix .T by the preceding name swapping process.

```

DELETE (TESTDB.IMS11A.ITHIDM02.DBDS1.T
)
IDC0550I ENTRY (D) TESTDB.IMS11A.ITHIDM02.DBDS1.DATA.T DELETED
IDC0550I ENTRY (C) TESTDB.IMS11A.ITHIDM02.DBDS1.T DELETED
IDC0001I FUNCTION COMPLETED, HIGHEST CONDITION CODE WAS 0

DELETE (TESTDB.IMS11A.ITHIDM01.DBDS1.T
)
IDC0550I ENTRY (D) TESTDB.IMS11A.ITHIDM01.DBDS1.DATA.T DELETED
IDC0550I ENTRY (I) TESTDB.IMS11A.ITHIDM01.DBDS1.INDEX.T DELETED
IDC0550I ENTRY (C) TESTDB.IMS11A.ITHIDM01.DBDS1.T DELETED
IDC0001I FUNCTION COMPLETED, HIGHEST CONDITION CODE WAS 0

DELETE (TESTDB.IMS11A.ITHIDM04.DBDS1.T
)
IDC0550I ENTRY (D) TESTDB.IMS11A.ITHIDM04.DBDS1.DATA.T DELETED
IDC0550I ENTRY (C) TESTDB.IMS11A.ITHIDM04.DBDS1.T DELETED
IDC0001I FUNCTION COMPLETED, HIGHEST CONDITION CODE WAS 0

DELETE (TESTDB.IMS11A.ITHIDM03.DBDS1.T
)
IDC0550I ENTRY (D) TESTDB.IMS11A.ITHIDM03.DBDS1.DATA.T DELETED
IDC0550I ENTRY (I) TESTDB.IMS11A.ITHIDM03.DBDS1.INDEX.T DELETED
IDC0550I ENTRY (C) TESTDB.IMS11A.ITHIDM03.DBDS1.T DELETED
IDC0001I FUNCTION COMPLETED, HIGHEST CONDITION CODE WAS 0

IDC0002I IDCAMS PROCESSING COMPLETE. MAXIMUM CONDITION CODE WAS 0
    
```

Figure 128. Result of Old Data Sets Deletion report (Post-reorganization utility)

## DBRC Processing for Restoring Authorization Flags report (Post-reorganization utility)

The DBRC Processing for Restoring Authorization Flags report contains the DBRC processing information for restoring authorization flags.

The following figure shows the report that is produced when DBRC commands are issued by the Post-reorganization utility during DBRC processing for restoring authorization flags in the RECON data sets.

For information about DBRC processing, see [“Automated DBRC processing for restoring authorization flags” on page 291.](#)

```

IMS DB REORG EXPERT          "DBRC PROCESSING FOR RESTORING AUTHORIZATION FLAGS"          PAGE: 1
5655-S35                    07/01/2023 21.52.57

CHANGE.DB DBD(ITHIDM02) AUTH READOFF
DSP0203I COMMAND COMPLETED WITH CONDITION CODE 00
DSP0220I COMMAND COMPLETION TIME 23.183 21:53:00.3
IMS DB REORG EXPERT          "DBRC PROCESSING FOR RESTORING AUTHORIZATION FLAGS"          PAGE: 2
5655-S35                    07/01/2023 21.52.57

CHANGE.DB DBD(ITHIDM01) AUTH READOFF
DSP0203I COMMAND COMPLETED WITH CONDITION CODE 00
DSP0220I COMMAND COMPLETION TIME 23.183 21:53:00.3
IMS DB REORG EXPERT          "DBRC PROCESSING FOR RESTORING AUTHORIZATION FLAGS"          PAGE: 3
5655-S35                    07/01/2023 21.52.57

CHANGE.DB DBD(ITHIDM04) AUTH READOFF
DSP0203I COMMAND COMPLETED WITH CONDITION CODE 00
DSP0220I COMMAND COMPLETION TIME 23.183 21:53:00.3
IMS DB REORG EXPERT          "DBRC PROCESSING FOR RESTORING AUTHORIZATION FLAGS"          PAGE: 4
5655-S35                    07/01/2023 21.52.57

CHANGE.DB DBD(ITHIDM03) AUTH READOFF
DSP0203I COMMAND COMPLETED WITH CONDITION CODE 00
DSP0220I COMMAND COMPLETION TIME 23.183 21:53:00.3
IMS DB REORG EXPERT          "DBRC PROCESSING FOR RESTORING AUTHORIZATION FLAGS"          PAGE: 5
5655-S35                    07/01/2023 21.52.57

DSP0211I COMMAND PROCESSING COMPLETE
DSP0211I HIGHEST CONDITION CODE = 00
    
```

Figure 129. DBRC Processing for restoring authorization flags (Post-reorganization utility)

## IMS Command Processing report (Post-reorganization utility)

The IMS Command Processing report contains the IMS command processing information.

The following figure shows an example of the IMS Command Processing report. This report is produced when IMSCMD=YES,TOSI is specified in Pre-reorganization utility JCL and one or more IMS commands are issued to the IMS online subsystems through the IMS Tools Online System Interface.

IMS DB REORG EXPERT  
5655-S35

"IMS COMMAND PROCESSING"

PAGE: 1  
07/01/2023 23.48.54

IMS COMMAND: /DBR DB DBNAME LOCAL NOFE0V  
TOSI WAIT: 300 SEC

IMSID	DBNAME	REQ	RES	RC	RSN	STATUS
IMA1	ITHIDM02	Y	Y	00	00	DFS0488I RC=00
	ITHIDM01	Y	Y	00	00	DFS0488I RC=00
	ITHIDM04	Y	Y	00	00	DFS0488I RC=00
	ITHIDM03	Y	Y	00	00	DFS0488I RC=00

Figure 130. IMS Command Processing report (Post-reorganization utility)

---

## Part 5. Unloading a database

The following topics explain how to unload a database by using the IPR Unload utility.

**Topics:**

- [Chapter 23, “IPR Unload utility,” on page 351](#)
- [Chapter 24, “Running an unload job,” on page 357](#)
- [Chapter 25, “IPR Unload JCL requirements,” on page 359](#)
- [Chapter 26, “IPR Unload control statements,” on page 367](#)
- [Chapter 27, “IPR Unload JCL examples,” on page 405](#)
- [Chapter 28, “IPR Unload reports,” on page 409](#)
- [Chapter 29, “User exits for IPR Unload,” on page 455](#)
- [Chapter 30, “Application programming interface for IPR Unload utility,” on page 461](#)
- [Chapter 31, “Tips for unloading damaged databases,” on page 481](#)



---

## Chapter 23. IPR Unload utility

These topics explain the IPR Unload utility.

### Topics:

- [“IPR Unload overview” on page 351](#)
- [“IPR Unload features” on page 351](#)
- [“Data flow for IPR Unload” on page 353](#)
- [“IPR Unload restrictions and considerations” on page 354](#)

---

### IPR Unload overview

The IPR Unload utility is a functional replacement of IMS HD Reorganization Unload utility (DFSURGU0). The IPR Unload utility unloads IMS HDAM, HIDAM, PHDAM, PHIDAM, HISAM, and SHISAM databases by using the high-performance segment retrieval engine and HSSR Engine of IMS HP Unload.

The IPR Unload utility can unload damaged databases by skipping error conditions.

---

### IPR Unload features

This topic introduces the features of the IPR Unload utility.

#### Fast unloading of IMS databases

The IPR Unload utility performs fast unloading of IMS databases, which can increase the efficiency of the database reorganization process. This function is provided by HSSR Engine of IMS HP Unload.

To further enhance the performance of the unload function, the IPR Unload utility:

- Unloads the compressed segments without decompressing them
- Bypasses the retrieval of logical parent concatenated keys (LPCKs)

**Note:** These options can be deactivated by using control statements.

To enhance the performance of writing unloaded segment into the unload data set, the IPR Unload utility supports the option to write the unloaded records with abbreviated short header (SH unload format).

#### Migration unload and fallback unload functions for HALDBs

The IPR Unload utility can unload a HIDAM or HDAM database for migration to a PHIDAM or PHDAM database. This function is called the *migration unload*.

The IPR Unload utility can also unload a PHIDAM or PHDAM database for migration to an HIDAM or HDAM database. This function is called the *fallback unload*.

The created unloaded data sets are compatible with the unloaded data sets that are created by the IMS HD Reorganization Unload utility.

#### Dynamic allocation of database data sets

If the DD statements for the data sets are not coded in the JCL stream, the database data sets of the database to be unloaded can be dynamically allocated.

For HDAM, HIDAM, HISAM, and SHISAM databases, you need to specify the library that contains the DFSMDA members for dynamic allocation on the JOBLIB, the STEPLIB, or the IMSDALIB DD.

## Support various database organizations

The IPR Unload utility supports the following database organizations:

- HDAM (Hierarchical Direct Access Method)
- HIDAM (Hierarchical Indexed Direct Access Method)
- PHDAM (Partitioned HDAM)
- PHIDAM (Partitioned HIDAM)
- HISAM (Hierarchical Indexed Sequential Access Method)
- SHISAM (Simple HISAM)

You can unload a single partition or a selected sequence of partitions of a PHDAM or PHIDAM database. The partitions that are defined in RECON as online reorganization capable (OLRCAP) are also supported. For details, see [“PARTITION control statement”](#) on page 383.

Other database organizations are not supported by the IPR Unload utility.

### Notes:

- Secondary index databases and processing of a partitioned secondary index are not supported.
- IMS/ESA Partition Support Product for MVS/ESA (5697-A06) and IMS/ESA Partition Support Product for MVS/ESA Version 2 (5697-D85) are not supported.

## Various unload data set formats

The IPR Unload utility unloads IMS (S)HISAM databases, HD databases (HDAM and HIDAM), and partitioned HD databases (PHDAM and PHIDAM) into one of the following 11 formats:

HD, SH, CS, CP, F1, F2, F3, F6, A1, A2, A3, or A4

You can also use the user-defined header format UH. For the details, see [“USERHDR control statement”](#) on page 387.

By default, the IPR Unload utility creates an HD-format unloaded data set without decompressing compressed segments to reduce the CPU time and elapsed time. This HD-format unload data set can be reloaded by:

- The IPR Reload utility
- IMS HP Load

In addition to these utilities, the HD-format is acceptable as input to IMS HD Reorganization Reload utility (DFSURGL0) or other compatible utilities if the unloaded data set is created with the DECOMPRESS=YES option.

For HDAM, HIDAM and (S)HISAM databases, the IPR Reload utility supports formats other than HD:

- The SH (short header) format and the CS (communication industry standard) format are acceptable as input data set.
- Formats F1, F2, F3, F6, A3, and A4 can be reloaded by specifying the USERHDRX control statement.
- All formats can be reloaded by specifying the USERHDR control statement.

For PHDAM and PHIDAM databases, the IPR Reload utility supports formats other than PHD:

The CP (communication industry partitioned) format is acceptable as input data set.

For details, see [“Considerations”](#) on page 355 and [“OUTPUT control statement”](#) on page 375.

## Unload damaged databases

The IPR Unload utility can unload a damaged database. Some control statements are provided for this purpose. By specifying those options, the IPR Unload utility can skip the incorrect HD pointers or the incorrect HISAM records, print diagnostic information about the database errors, or help detect sequence



errors in the database. The unload data set might be missing some segments, but when the database is reloaded using this data set, it will be an error-free database from an IMS standpoint.

For details, see [“SKIPERROR control statement” on page 402](#) and [“DIAGG control statement” on page 399](#). For the general guideline of unloading damaged databases, see [Chapter 31, “Tips for unloading damaged databases,” on page 481](#).

## Provide user exits

The following two types of user exit are provided:

- Type-A user exit
- Type-B user exit

The Type-A user exit is compatible with FABHFSU unload utility of IMS HP Unload. A Type-A user exit routine can direct the utility to:

- skip the current segment
- skip the current database record
- resume processing at a root segment with a specified key

You can edit segment data using the user exit routine. Multiple Type-A exit routines can be specified in an unload job.

The Type-B user exit provides simpler call interface. A Type-B user exit routine can direct the utility to:

- skip the current segment
- skip or the current database record
- edit the current segment data

Only one Type-B exit routine can be specified in an unload job.

For the details of these exits, see [Chapter 29, “User exits for IPR Unload,” on page 455](#). See also [“OUTPUT control statement” on page 375](#) on how to specify the name and type of the exit routine.

## Statistics reports for database tuning aid

Statistics reports on a database, its data sets, its segments, its database record lengths and randomizing—which will be your valuable database tuning aid—can be generated. Using these reports, you can determine the need for a database reorganization. For details, see [Chapter 28, “IPR Unload reports,” on page 409](#).

## Application programming interface

You can retrieve segments faster by using API that enables batch DL/I application programs that reads a database sequentially by issuing GN calls to use HSSR Engine, than by using the IMS native DL/I action modules. You do not have to recompile or relink-edit the application program to use the API. For details, see [Chapter 30, “Application programming interface for IPR Unload utility,” on page 461](#).

## Store reports in the Output repository of IMS Tools KB

The IPR Unload utility can store the reports in the Output repository of IMS Tools KB by using the `ITKBSRVR=servername` control statement. To use this feature, you need to set up the environment. For details, see [“Task 2: Completing configuration for IMS Tools Knowledge Base” on page 44](#).

## Data flow for IPR Unload

---

This topic describes the data and the process flow for the IPR Unload utility.

The following figure shows the general data flow for the IPR Unload utility.

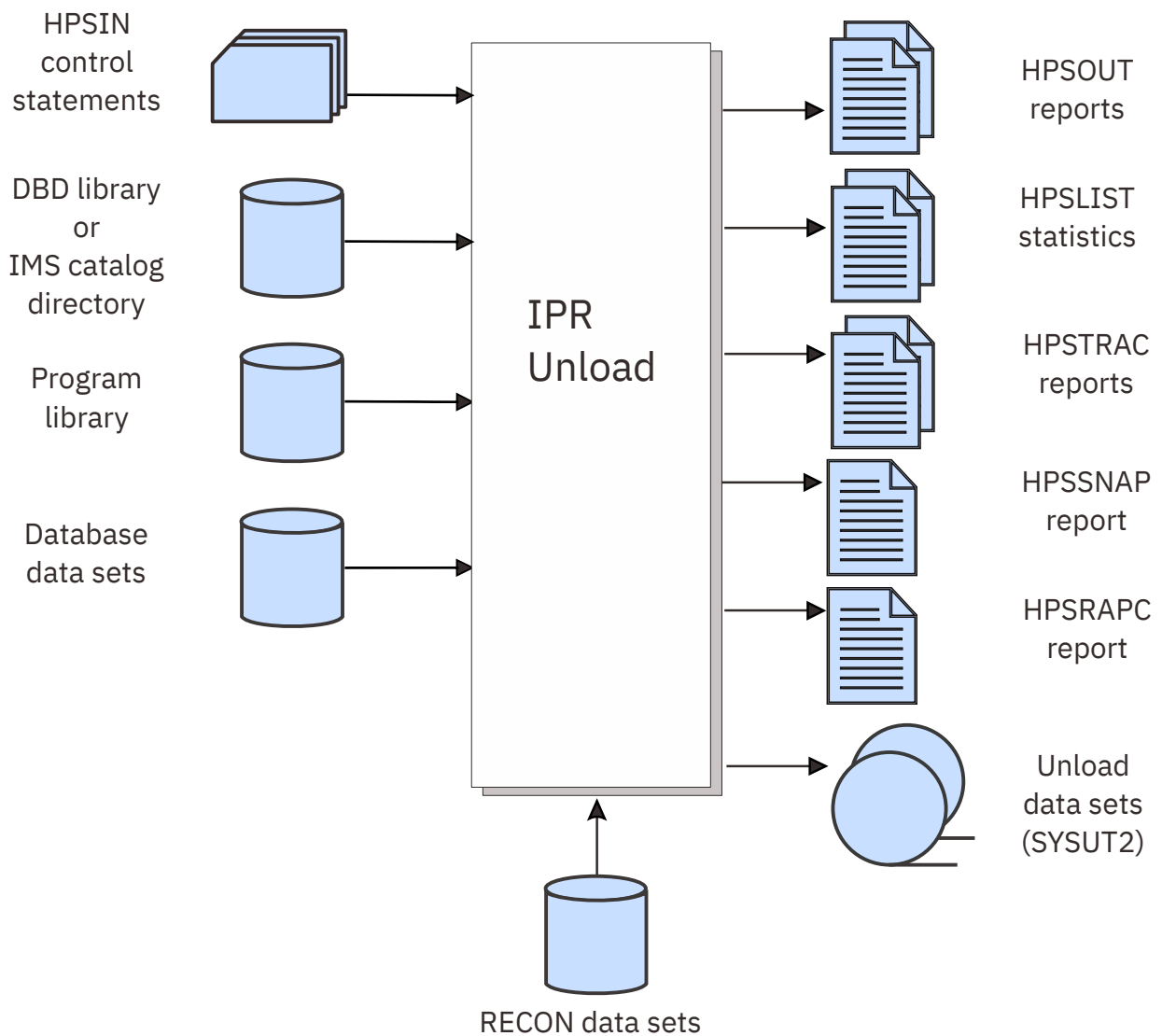

Figure 131. Data flow of the IPR Unload utility

## IPR Unload restrictions and considerations

The IPR Unload utility has certain restrictions.

### Restrictions

- Database organization types other than HDAM, HIDAM, PHDAM, PHIDAM, HISAM, and SHISAM are not supported.
- If IMS database versioning is enabled, only the current version of the database can be used. Any other versions of the database are not supported.
- Migration unload of secondary indexes is not supported.
- Migration unload of HISAM databases is not supported.
- If PTR=H or PTR=HB is defined as the parent segment of a virtual logical child, the IPR Unload utility does not support the migration unload of that database.
- Fallback unload of the partitioned secondary indexes (PSINDEXes) is not supported.
- If either of the following segment occurrences is skipped or lost during the unload, the IPR Unload utility cannot be used in a reorganization to unload a damaged database having logical relationships:

- A logical parent segment having one or more logical children
- A logical child segment that is physically paired
- You must ensure that no segments required by the IMS HD Reorganization Reload utility are missing during reorganization for the following reason:
  - Having a user exit routine that sets a return code indicating some segments must be skipped.
- The IPR Unload utility supports PHDAM or PHIDAM partitions that are defined as capable of HALDB Online Reorganization (OLR). If one or more partitions are in the following HALDB OLR status, the IPR Unload utility cannot process the HALDB:
  - HALDB OLR is currently running.
  - HALDB OLR is stopped before the completion for the partition and one of the following options is specified:
    - DECOMPRESS=NO
    - User exit
    - \*CS format for PHDAM
    - \*A1 format
    - PARTITION=*partlist*

When none of the above options is specified, the IPR Unload utility can process the partition. The following options, however, are ignored:

- BYINDEX=YES
- COMPAREDLI=YES
- DBSTATS=YES
- KEYCHECK=ABEND/GG/GX
- SKIPERROR=*nnnnn*

and the following reports are suppressed:

- Segment Statistics report
- Distribution of Database Record Sizes report
- Largest Database Records report
- HDAM Root Addressable Area Statistics report

In this case, the performance decreases because the HSSR Engine passes the DL/I calls to the IMS's DL/I call handler from the partition. IBM recommends that you run the IPR Unload utility after the completion of the HALDB OLR.

## Considerations

The following topics describe the considerations for various processes.

### Considerations for logical parent's concatenated key

For a logical child segment with a logical parent's concatenated key (LPCK) that is specified as "virtual" on the SEGM statement of the DBD, the IPR Unload utility returns, by default, blanks in the I/O area that typically contains LPCK.

To have HSSR Engine build the LPCK and return it to the I/O area, you must specify BLDLPCK=YES control statement in the HPSIN data set. For details, see [“BLDLPCK control statement” on page 392](#).

When you unload an undamaged database that has a logical child whose LPCK is defined as virtual, and if BLDLPCK=YES is not specified, you must run the IMS Database Preorganization utility with the control statement DBR= to get a successful reload and prefix resolution. In this case, the control statement DBIL= gives incorrect results.

You must specify BLDLPCK=YES when you unload a damaged database that has a logical pointer error in a logical child whose LPCK is defined as virtual. Because you suspect that logical pointers are incorrect, you must also run the IMS Database Prereorganization utility, using the DBIL= control statement. Otherwise, you will get an incorrect reload that would be detected during prefix resolution.

For the general guideline of unloading damaged databases, see [Chapter 31, “Tips for unloading damaged databases,”](#) on page 481.

### **Considerations for unload data sets used for reorganization**

By default, an HD-format unload data set is created without decompressing compressed segments. The data set can be used as the input to the IPR Reload utility and IMS HP Load, but if a compressed segment exists in the database, the data set cannot be used as input to the IMS HD Reorganization Reload utility (DFSURGLO).

For such a database, specify DECOMPRESS=YES in HPSIN. The resulting unload data set will then be compatible with the one created by the IMS standard HD Reorganization Unload utility (DFSURGU0), and can be reloaded by using DFSURGLO or other compatible utilities.

There is the following difference, but it does not affect DFSURGLO:

- IMS overrides the BLKSIZE specified in the JCL stream with the computed values. The IPR Unload utility overrides it with the BLKSIZE specified.

### **Considerations for database-sharing**

In general, like any other unload utility during reorganization, the IPR Unload utility must have exclusive control of the database while they are running.

HSSR Engine provides the same support for database level sharing as IMS. This support requires that DBRC is active. If DBRC is active and all data sets of the database are registered to DBRC, DBRC authorizes database access to the IPR Unload utility under the same conditions as to the standard IMS HD Reorganization Unload utility. HSSR Engine makes IMS and DBRC assume that it is the IMS HD Reorganization Unload utility that is being run.

#### *Considerations for compatibility with FABHURG1 and FABHFSU*

If DECOMPRESS=YES is specified for the IPR Unload utility, the following pairs of unload formats (the latter with asterisks \* are of FABHURG1 unload utility of IMS HP Unload) are compatible:

- HD and \*HD
- CS and \*CS
- F1 and \*F1
- F2 and \*F2
- F3 and \*F3

If DECOMPRESS=YES is specified for the IPR Unload utility, the unload format HD and F1 are compatible with the unload formats UL and VB of FABHFSU unload utility of IMS HP Unload respectively. Note, however, that, by default, for a logical child segment with virtual LPCK defined, the IPR Unload utility returns blanks in the LPCK area, whereas FABHFSU returns binary zeros.

---

## Chapter 24. Running an unload job

The following topics describe how to use the IPR Unload utility to unload IMS databases.

### Topics:

- [“Unloading a database” on page 357](#)
- [“Unloading a damaged database” on page 357](#)

---

### Unloading a database

This topic describes the steps to unload a database with the IPR Unload utility.

#### Procedure

To unload a database with the IPR Unload utility, do the following:

1. For a HALDB, select an unload method: unload the entire database, unload a single partition, or unload a selected sequence of partitions.  
Code a PARTITION control statement if you want to unload a single partition or a selected sequence of partitions.  
For details, see [“PARTITION control statement” on page 383](#).
2. Select the output format and code an OUTPUT control statement if required.  
For details, see [“OUTPUT control statement” on page 375](#).
3. Code other HPSIN control statements if required.  
For details, see [Chapter 26, “IPR Unload control statements,” on page 367](#).
4. Code other DD statements and run the IPR Unload utility job.  
For details, see [Chapter 25, “IPR Unload JCL requirements,” on page 359](#).
5. Review output reports and messages.  
For details, see [Chapter 28, “IPR Unload reports,” on page 409](#).

---

### Unloading a damaged database

This topic describes the steps for unloading a damaged database.

#### About this task

You can use the IPR Unload utility to unload a damaged database. Before you use the IPR Unload utility for the damaged database, first read [Chapter 31, “Tips for unloading damaged databases,” on page 481](#) and follow the rules described in the topic.

**Tip:** Before unloading a damaged database, see [Chapter 31, “Tips for unloading damaged databases,” on page 481](#).

#### Procedure

To unload a damaged database with the IPR Unload utility, complete the following steps:

1. Select the output format.
2. Code the HPSIN control statements SKIPERROR, DIAGG=YES, and KEYCHECK=GG.  
For details of SKIPERROR, DIAGG, and KEYCHECK control statements, see [“Syntax for the IPR Unload control statements” on page 367](#).
3. If required, code other HPSIN control statements.

4. Code the HPSTRACE DD statement in the JCL stream.
5. If required, code other DD statements, and run the IPR Unload utility job.
6. Review output reports and messages.
7. Analyze the HSSR Trace Output report with diagnostics printed in HPSTRACE data set.  
For a detailed description of HSSR Trace Output report with diagnostics, read the explanations on reports and output for HSSR Engine in the *IMS High Performance Unload User's Guide*.

---

## Chapter 25. IPR Unload JCL requirements

To use the IPR Unload utility, supply an EXEC statement with PARM parameters, and appropriate DD statements.

If you want to use the JCL that is written for IMS HD Reorganization Unload (DFSURGU0), see [“Using JCL for IMS HD Reorganization Unload”](#) on page 364.

### Topics:

- [“EXEC statement”](#) on page 359
- [“DD statements”](#) on page 360
- [“Using JCL for IMS HD Reorganization Unload”](#) on page 364

---

## EXEC statement

This topic describes the EXEC statement for the IPR Unload utility.

The EXEC statement for the IPR Unload utility must be in the following format:

```
//name EXEC PGM=HPSCMAIN,  
//          PARM=' FUNC=UL , DBD=dbdname'
```

Specify HPSCMAIN as the program name. The PARM= parameter keywords are as follows:

### **FUNC=UL**

Invokes the IPR Unload utility function to unload the database. This parameter is required.

### **DBD=*dbdname***

Specifies the name of the DBD that includes the database to be unloaded. This parameter is required.

Optionally, you can specify the following keywords to specify the job step environment:

### **DBRC=*x***

Specifies whether the IPR Unload utility uses DBRC.

**Y**

DBRC is used.

**N**

DBRC is not used unless the DBRC=FORCE option is specified during IMS system generation.

If this parameter is not specified, the default setting determined by IMS system generation is used.

### **IMSPLEX=*name***

Specifies the IMSplex name that is to be used by IMS DBRC SCI Registration. This parameter is 1- to 5-characters.

### **DBRCGRP=*ccc***

Specifies the DBRC group identifier that is to be used by IMS DBRC SCI Registration. This parameter is 3 characters.

### **SWAP=**

Makes the address space swappable or non-swappable.

**Y**

The address space is made swappable.

**N**

The address space is made non-swappable.

The default is N.

### **IRLM=*x***

Specifies whether the IPR Unload utility uses IRLM.

**Y**

IRLM is used.

**N**

IRLM is not used.

If this parameter is not specified, the default setting determined by IMS system generation is used.

**IRLMNM=name**

Specifies the IRLM subsystem name (a 1-to-4-character alphanumeric name), if IRLM=Y is specified.

**GSGNAME=name**

Specifies the name of the global service group (GSG).

**DFSDF=ccc**

Specifies the 3-character suffix of the DFSDFxxx member of the IMS.PROCLIB data set. You must also specify the PROCLIB DD statement.

## DD statements

DD statements are used to identify the source of input and the placement of output information.

This topic describes each DD statement. The following table summarizes the DD statements for the IPR Unload utility.

*Table 44. DD statements and record format for the IPR Unload utility*

<b>DDNAME</b>	<b>Use</b>	<b>Format</b>	<b>Need</b>
STEPLIB	Input		Required
DFSRESLB	Input		Optional (See <a href="#">Note 1</a> )
IMS	Input		Optional
<i>ddname</i>	Input		Optional (See <a href="#">Note 2</a> )
IMSDALIB	Input		Optional (See <a href="#">Note 3</a> )
DFSVSAMP	Input	LRECL=80, RECFM=FB	Optional
HPSIN	Input	LRECL=80, RECFM=FB	Optional
PROCLIB	Input		Optional
RECONx	Input		Optional
SYSUT1	Input		Optional
HPSOUT	Output	LRECL=81, RECFM=FBA	Required (See <a href="#">Note 4</a> )
HPSLIST	Output	LRECL=133, RECFM=FBA	Optional (See <a href="#">Note 4</a> )
HPSTRACE	Output	LRECL=133, RECFM=FBA	Optional (See <a href="#">Note 4</a> )
HPSRAPC	Output	LRECL=81, RECFM=FBA	Optional (See <a href="#">Note 4</a> )
HPSSNAP	Output	LRECL=121, RECFM=VBA	Optional (See <a href="#">Note 4</a> )
HPSLOUT	Output		Optional
SYSUDUMP	Output	LRECL=133	Optional
SYSUT2	Output		Required (See <a href="#">Note 5</a> )
SYSUT3	Output		Optional (See <a href="#">Note 6</a> )



Table 44. DD statements and record format for the IPR Unload utility (continued)

DDNAME	Use	Format	Need
SYSUT4	Output		Optional (See <a href="#">Note 6</a> )
DFSURGU1	Output		Optional (See <a href="#">Note 7</a> )
DFSURGU2	Output		Optional (See <a href="#">Note 7</a> )

**Notes:**

1. If a library concatenated to STEPLIB is not APF-authorized, the DFSRESLB DD statement is required.
2. If you use dynamic allocation, do not use the DD statement for the database data sets.
3. If the library is not APF-authorized, you can specify on this statement the library that contains DFSMDA members.
4. If these DD statements are not specified, the IPR Unload utility dynamically allocates those DD statements to the SYSOUT stream in the following order:
  - HPSOUT
  - HPSLIST
  - HPSRAPC (if RAPCHECK=YES)
  - HPSTRACE (if COMPAREDLI=YES, DIAGG=YES, or TRACE=xxxx)
  - HPSSNAP
5. If you select the \*NO format for SYSUT2 (OUTPUT=SYSUT2,\*NO), this DD statement is not required.
6. If you specify SYSUT3 or SYSUT4 (OUTPUT=SYSUT3 or OUTPUT=SYSUT4) and select an output format other than \*NO, this DD statement is required.
7. You can use the DFSURGU1 statement and the DFSURGU2 DD statement only if the SYSUT2 DD statement is not specified.

**STEPLIB DD**

Points to the following libraries:

- IMS Database Reorganization Expert load module library (mandatory)
- IMS HP Unload load module library (mandatory)
- IMS Library Integrity Utilities load module library (either one is required when DECODEDBD=YES)
- IMS RESLIB library (mandatory)
- The load module library that contains user routines (optional)
- The library that contains DFSMDA members for dynamic allocation of data sets (optional). If you specify this library on the IMSDALIB DD statement, it is highly recommended that you remove the library from the STEPLIB concatenation.
- IMS Tools KB load module library (optional). If ITKBSRVR=servername is specified and ITKBLOAD=libname is not specified, this library is required.
- The SGLXLOAD library of IMS Tools Base (optional)

To unload a database in an IMS-managed ACBs environment or offload eligible workloads to zIIP processors, you must add the SGLXLOAD library of IMS Tools Base to the STEPLIB DD concatenation.

- IMS Catalog Definition exit routine (DFS3CDX0) library (optional)

To unload a database in an IMS-managed ACBs environment without specifying the DFSDF= parameter keyword to the EXEC statement or unload an IMS catalog database that is not registered in the RECON data sets, you must add the IMS Catalog Definition exit routine library to the STEPLIB DD concatenation.

The IMS HP Unload load module library must be concatenated before the IMS RESLIB library.

This DD statement is required.

**Notes:**

- You do not need to APF-authorize the STEPLIB libraries for the IPR Unload utility. If, however, the STEPLIB is not authorized (by having unauthorized libraries concatenated, for example), the DFSRESLB DD statement must be specified.
- If all concatenations of the JOBLIB/STEPLIB are APF-authorized, the IPR Unload utility uses Media Manager for reading VSAM ESDS database data sets and OSAM LDS database data sets to reduce CPU time.

**DFSRESLB DD**

Points to an APF-authorized library that contains IMS SVC modules. For an IPR Unload utility job, IMS RESLIB and any data set that is concatenated to it on the DFSRESLB DD statement must be APF-authorized. For details, see the topic that explains how to specify the DFSRESLB DD statement in IMS batch procedures in *IMS System Definition* for the version of IMS that you are using.

**IMS DD**

Describes the library containing the DBD. This data set must reside on a direct-access device. This DD statement is required unless the IMS management of ACBs is enabled. When the IMS management of ACBs is enabled, IMS system ignores the IMS DD statement.

**ddname DD**

These DD statements define the database data set to be processed. One statement of this type must be present for each data set that appears in the DBD that describes the database. The value of *ddname* must match the *ddname* in the DBD.

For a HIDAM database, DD statements must also exist for the data sets that specify the index. The DD statements that specify the index must contain *ddnames* specified in the DBD for the index database. No DD statements are required for any secondary indexes that are associated with this database.

If BLDLPCK=YES is specified in the HPSIN data set, the database in which the logical parent is defined must be specified.

You must not code DCB=BUFNO=*n* or AMP='BUFND=*n*' options to request access method buffers for database data sets; HSSR Engine allocates its own buffer pool for each data set group.

**Note:** If you use the dynamic allocation, do not use the DD statement for the database data sets.

For HALDBs, no DD statement needs to be specified for any database data set because the data set is always dynamically allocated.

**IMSDALIB DD**

Specifies the library that contains the DFSMDA members for dynamic allocation. Allocation of the database data sets and the RECON data sets will be attempted in the following order:

1. The DD statements coded in the JCL stream
2. Dynamic allocation by data set definition that is contained in RECON (only for HALDB data sets)
3. Dynamic allocation members in the IMSDALIB concatenation or in the JOBLIB/STEPLIB concatenation

If you specify this library on the IMSDALIB DD statement, it is highly recommended that you remove the library from the STEPLIB concatenation.

**DFSVSAMP DD**

Describes the data set that contains the buffer pool information required by the IMS DL/I buffer handler. This data set, when not specified, is dynamically created by the IPR Unload utility. Therefore, this data set must not normally be specified. If you want to specify this data set, specify the minimum required number of buffers in the DFSVSAMP data set because the IPR Unload utility does not use the buffers taken with the parameters specified in this data set. Otherwise, a larger number of region size is required to run the IPR Unload utility.

You must, however, specify DL/I buffers in the DFSVSAMP data set in the following cases:

- When you specify BLDLPCK=YES in the HPSIN data set because a DL/I call is issued internally to build an LPCK.
- When you do a migration unload of a database that has a logical child defined. In this case, HSSR Engine internally issues DL/I calls to obtain information to write in the header of the unload record of the logical child.
- When APISET=3 is specified in the HPSIN data set or in the Site Default Option Table. In this case, if a call that is not supported in APISET=2 is issued, that call and all succeeding calls are passed to DL/I and are processed by DL/I action modules.

The ordinary DFSVSAMP definitions must be used to tune the processing of these internal DL/I calls.

#### **HPSIN DD**

Defines an optional data set that contains control statements specifying the optional functions of the IPR Unload utility. For details, see [Chapter 26, “IPR Unload control statements,” on page 367](#).

#### **PROCLIB DD**

Points to the IMS.PROCLIB data set. If DFSDF=ccc is specified on the EXEC statement, you must specify this DD statement and ensure that the DFSDFccc member exists in the IMS.PROCLIB data set.

#### **RECONx DD**

This statement provides RECON1, RECON2, and RECON3 DD statements under the same conditions as for standard IMS jobs. If RECON data sets are allocated dynamically, do not specify these DD statements.

IBM recommends that you have the IPR Unload utility allocate these data sets dynamically.

#### **SYSUT1 DD**

Defines an optional input data set created (in a previous step) by the IMS HD Reorganization Unload utility. Use it only for problem determination. This data set activates a comparison of HD output records to be written into the SYSUT2 data set with the output records created by the IMS HD Reorganization Unload utility. The IPR Unload utility does not compare the lengths of the header or trailer records.

**Note:** If you use the SYSUT1 DD, DECOMPRESS=YES must be specified in the HPSIN data set.

#### **HPSOUT DD**

Defines the main output data set for reports and statistics. The data set can reside on a tape, a direct-access device, or it can be routed through the output stream. For details, see [Chapter 28, “IPR Unload reports,” on page 409](#).

This DD statement is required.

#### **HPSLIST DD**

Defines the optional output data set in which the statistics produced by HSSR Engine is written. The data set can reside on a tape or a direct-access device, or it can be routed through the output stream. For details, see [Chapter 28, “IPR Unload reports,” on page 409](#).

#### **HPSTRACE DD**

Defines a trace output data set. It is required whenever any of the following options have been activated by the HPSIN control statements: COMPAREDLI=YES, DIAGG=YES, or TRACE. The data set can reside on a tape or a direct-access device, or it can be routed through the output stream. For details, see [Chapter 28, “IPR Unload reports,” on page 409](#).

#### **HPSRAPC DD**

Defines the optional output data set in which the check report is written when RAPCHECK=YES is specified. The data set can reside on a tape, a direct-access device, or it can be routed through the output stream. For details, see [Chapter 28, “IPR Unload reports,” on page 409](#).

#### **HPSSNAP DD**

This required statement defines the output data set on which snapshots of control blocks of HSSR Engine are written when an error occurs during initialization of HSSR Engine. The data set can reside on a tape, a direct-access device, or it can be routed through the output stream. For details, see [Chapter 28, “IPR Unload reports,” on page 409](#).

## HPSLOUT DD

This optional statement defines the output sequential data set that is used when the LOUT control statement is specified. For the details, see “LOUT control statement” on page 400.

**Note:** The BLKSIZE and LRECL for this data set should not be specified on JCL. They are determined dynamically by HSSR Engine based on the key length of the root segment. The LRECL is 8 bytes plus the length of the key of the database root segment.

## SYSUT2 DD

## SYSUT3 DD

## SYSUT4 DD

Defines the output data set on which the database is unloaded. The data set must reside on either a tape or a direct-access device. It can also be defined as DUMMY.

If a block size is not specified on the SYSUT $n$  DD statement, the IPR Unload utility uses the half track size for each device type. If the database contains segments larger than the block size, the maximum block size 32 K is used.

Do not specify the LRECL value on the DD statement. The IPR Unload utility uses the default record size (that is, block size minus 4).

Large format data sets can be specified.

The IPR Unload utility uses BUFNO=24 as the default buffer number. When the default buffer number is used, the buffer is allocated above the 16 MB line. If you want to change the buffer number, specify DCB=BUFNO= $nn$  on the DD statement.

## DFSURGU1 DD

## DFSURGU2 DD

Defines the output data set to which the database is unloaded the same way as the SYSUT $n$  DD. These statements are available only when the SYSUT2 DD statement is not specified.

## Using JCL for IMS HD Reorganization Unload

You can use the JCL stream that is written for IMS HD Reorganization Unload (DFSURGU0) to run the IPR Unload utility.

## Steps to run the JCL for IMS HD Reorganization Unload

This topic describes the steps to use the JCL stream for IMS HD Reorganization Unload.

### Procedure

To use JCL that is written for IMS HD Reorganization Unload (DFSURGU0), complete the following steps:

1. Add alias name DFSISVIO.

Add alias name DFSISVIO to the library of IMS HP Unload as shown in the following JCL stream:

```
//LINK      EXEC PGM=IEWL,
//          PARM='LIST,LET,XREF'
//SYSPRINT DD SYSOUT=*
//SHPSLMD0 DD DISP=SHR,DSN=HPS.SHPSLMD0
//SYSLMOD  DD DISP=SHR,DSN=HPS.SHPSLMD0
//SYSUT1   DD UNIT=SYSDA,SPACE=(CYL,(1,1))
//SYSLIN   DD *
           ENTRY FABHSVIO
           INCLUDE SHPSLMD0(FABHSVIO)
           ALIAS  DFSISVIO
           NAME   FABHSVIO(R)
/*
```

2. Modify the Installation Default Option Table (HPSCOPTI).

Add the JCLTYPE=DFS option to the Installation Default Option Table (HPSCOPTI):

```
HPSCOPT START
HPSCOPT UNLOAD,JCLTYPE=DFS
HPSCOPT END
```

If the system default DECOMPRESS=NO is not acceptable, add the DECOMPRESS=YES option. You can add the other options to change the system default. For more information, see Chapter 45, “Setting installation default options,” on page 617, and “DECOMPRESS control statement” on page 372.

### 3. Modify the unload JCL.

In an unload JCL stream, modify the STEPLIB DD statement so that the load module libraries of IMS Database Reorganization Expert and IMS HP Unload are placed. If you want to use the optional functions of the IPR Unload utility, add the HPSIN DD statement and control statements listed in Chapter 26, “IPR Unload control statements,” on page 367. For the sample JCL stream, see “Example 4: Unloading using JCL for IMS HD Reorganization Unload” on page 406.

### 4. Run the unload JCL.

Submit the unload JCL stream. If the above steps are done correctly, the IPR Unload utility is invoked from the DFSISVIO exit and message HPSU3003I will be shown. When the JCLTYPE=DFS option or the HPSIN DD statement is not found, the FABHURG1 unload utility might be invoked.

## EXEC statement and DD statements

This topic describes the EXEC statement and the DD statements for using the JCL for IMS HD Reorganization Unload.

For samples of JCL streams, see “Example 4: Unloading using JCL for IMS HD Reorganization Unload” on page 406.

### EXEC statement

The parameters ULU and DFSURGU0 must be specified.

### DD statements

#### STEPLIB DD

Add the SHPSLMD0 libraries of IMS Database Reorganization Expert and IMS HP Unload to this DD statement. The DFSISVIO member must be placed in a library.

#### SYSIN DD

This optional statement defines the input control statement data set for IMS HD Reorganization Unload (DFSURGU0).

#### HPSIN DD

This optional statement defines the input control statement data set for the IPR Unload utility. For more information, see Chapter 26, “IPR Unload control statements,” on page 367.

#### SYSPRINT DD

This required statement defines the main output data set for reports and statistics instead of HPSOUT DD.

#### DFSURGU1 DD

This required statement defines the primary output data set instead of SYSUT2 DD.

#### DFSURGU2 DD

This optional statement defines the secondary output data set instead of SYSUT3 DD.

#### database DD

The DD statements for database data sets are optional. If the DD statements are not present for a non-partitioned database, dynamic allocation will be done by using the DFSMDA member if one is present in STEPLIB or IMSDALIB.

For the other optional data sets, see “DD statements” on page 360.

**Note:** The DFSUCKPT DD statement and the DFSURSRT DD statement are not supported.

## Restrictions

Certain restrictions apply to using the JCL for HD Reorganization Unload.

- The restrictions in [“IPR Unload restrictions and considerations”](#) on page 354 apply to this processing.
- Media manager is not used to read VSAM database data sets even if all concatenations of the JOBLIB/STEPLIB are APF-authorized.
- The following functions of IMS HD Reorganization unload (DFSURGU0) is not supported.
  - DFSUCKPT DD for the checkpoint function
  - DFSURSRT DD for the restart function
  - IMS SB (sequential buffering)
- As system default, the compressed segment data is written to the unload data set without expanding it. If the system default is not acceptable, use the DECOMPRESS=YES option. For more information, see [“DECOMPRESS control statement”](#) on page 372.

---

## Chapter 26. IPR Unload control statements

The control statements for the IPR Unload utility are specified in the HPSIN data set. You can choose which options to enable by coding control statements.

There are two categories of control statements:

- Control statements for the unload function
- Control statements for HSSR Engine

### Topics:

- [“Syntax for the IPR Unload control statements” on page 367](#)
- [“Control statements for the unload function” on page 367](#)
- [“Control statements for HSSR Engine” on page 389](#)

---

### Syntax for the IPR Unload control statements

The control statements must conform to the following syntax rules:

A keyword and its associated value can be coded in a free format (columns 1-80) provided the following syntactical coding rules are followed:

- A keyword and its value must be on a single control statement.
- A keyword must be separated from its associated value by an equal sign (=). The equal sign must not be preceded by blanks, and not be followed by blanks; that is, a null value is not allowed.
- A comment line must begin with an asterisk (\*) in column 1.
- You can specify Y for YES and N for NO.

---

### Control statements for the unload function

This topic summarizes the HPSIN control statements that are used for controlling the unload function.

The following control statements can be coded to control the unload function.

The following table shows control statements for unload functions.

---

*Table 45. Control statements for unload function*

Keyword	Acceptable values	Default	Description
CHECKREC	YES or NO	NO	Specifies whether the check record used by IPR Reload utility is added to the unload data set. See <a href="#">“CHECKREC control statement” on page 370</a> .
DBRECDIST	<i>a</i> or ( <i>b1</i> ,..., <i>b20</i> ) <i>a</i> =0 - 9999999 <i>bn</i> =1 - 9999999	(100,200,300,400,500, 600,700,800,900,1000, 2000,3000,4000,5000, 6000,7000,8000,9000, 10000)	Specifies the range of database record sizes you want to show in the Distribution of Database Record Sizes report. The range will be shown under "RANGE." See <a href="#">“DBRECDIST control statement” on page 370</a> .

---

Table 45. Control statements for unload function (continued)

Keyword	Acceptable values	Default	Description
DBRECKEYS	0 - 999	10	Specifies the number of the largest database records to be listed in the Largest Database Records report. See <a href="#">“DBRECKEYS control statement”</a> on page 371.
DECODEDBD	YES or NO	NO	Specifies whether the DBD is to be decoded. See <a href="#">“DECODEDBD control statement”</a> on page 371.
DECOMPRESS	YES or NO	NO	Specifies whether to decompress the compressed segments or not. See <a href="#">“DECOMPRESS control statement”</a> on page 372.
FALLBACK	YES or NO	NO	Specifies whether to activate the fallback unload function for migration from a HALDB to a non-HALDB. See <a href="#">“FALLBACK control statement”</a> on page 372.
HOMECHK	0 or (-a,+b) a=1 - 998 b=1 - 998	(-10,+10)	Specifies the range of the relative locations of the database record you want to show in the HDAM Root Addressable Area Statistics report. The range will be shown under "LOCATION" in the HDAM Root Placement topic. See <a href="#">“HOMECHK control statement”</a> on page 373.
ITKBLOAD	libname or *NO	*NO	Specifies the library name of IMS Tools KB. See <a href="#">“ITKBLOAD control statement”</a> on page 373.
ITKBSRVR	servername servername,ERRC04 *NO	*NO	Specifies the name of the IMS Tools KB server XCF group. See <a href="#">“ITKBSRVR control statement”</a> on page 374.



Table 45. Control statements for unload function (continued)

Keyword	Acceptable values	Default	Description
MIGRATE	YES or NO	NO	Specifies whether to activate the migration unload function for migration from a non-HALDB to a HALDB. See <a href="#">“MIGRATE control statement” on page 375.</a>
OUTPUT	See <a href="#">“OUTPUT control statement” on page 375.</a>	SYSUT2,*HD	Specifies the characteristics of the output data sets to be created and the optional user exit routine for the output. See <a href="#">“OUTPUT control statement” on page 375.</a>
PARTITION	( <i>partname,num</i> ), ( <i>part1,...,partn</i> ), or *ALL	*ALL	Specifies which HALDB partitions are to be unloaded. See <a href="#">“PARTITION control statement” on page 383.</a>
PROGMON	0 - 999999	0	Specifies whether a progress monitoring message is to be issued. See <a href="#">“PROGMON control statement” on page 384.</a>
RAPCHECK	YES or NO	NO	Specifies whether to activate the RAPCHECK option. See <a href="#">“RAPCHECK control statement” on page 385.</a>
SEGSEL	( <i>segma,...,segmz</i> ) or *ALL	*ALL	Specifies the segment names to be unloaded selectively. See <a href="#">“SEGSEL control statement” on page 385.</a>
SKIPAUTH	YES or NO	NO	Specifies whether to bypass IMS DBRC database authorization. See <a href="#">“SKIPAUTH control statement” on page 386.</a>
STATREP	NO or YES	YES	Specifies whether certain statistics reports are printed. See <a href="#">“STATREP control statement” on page 386.</a>

Table 45. Control statements for unload function (continued)

Keyword	Acceptable values	Default	Description
USERHDR	(elem1,...,elemN)		Specifies the list of the elements in the header portion of the *UH unload format record. See “USERHDR control statement” on page 387.

## CHECKREC control statement

Specifies whether the particular record is written just behind the header record in the unload data set.

This record is used by the IPR Reload utility for it to know certain status of the database at unloading time.

This control statement is used only for the \*HD or the \*SH unload format.

This control statement is optional. The default is CHECKREC=NO.

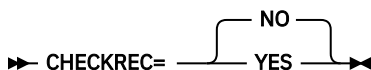

### YES

The particular record is written.

### NO

The particular record is not written.

**Tip:** You can change the default value of this control statement by creating an Installation Default Option Table (HPSCOPTI). For more information, see [Chapter 45, “Setting installation default options,”](#) on page 617.

## DBRECDIST control statement

Specifies whether to generate the Distribution of Database Record Sizes report, and if so, the range of database record sizes in bytes.

This control statement is optional. If you do not specify this control statement, default values are used.

**Usage note:** This control statement is not available for the Unload task of the Smart Reorg utility. If the control statement is specified, it is ignored.

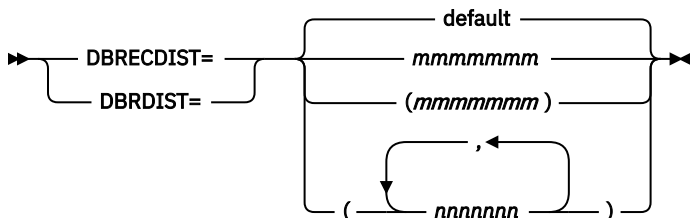

### default

If you do not specify the DBRECDIST control statement, the following values are used for the default of RANGE:

(100,200,300,400,500,600,700,800,900,1000,  
2000,3000,4000,5000,6000,7000,8000,9000,10000)

### **mmmmmmm**

Specify a 7-digit decimal number in the range of 0 - 9999999. The leading zero can be omitted. If you do not want to generate the Distribution of Database Record Sizes report, specify 0.

### **nnnnnnn**

Specify a 7-digit decimal number in the range of 1 - 9999999. The leading zeros can be omitted. For *nnnnnnn*, you can specify up to 20 different 7-digit decimal numbers in ascending order.

You can specify up to 20 values for the range (RANGE) of Distribution of Database Record Sizes report. If you want to specify multiple values for the range, you can either specify multiple 7-digit decimal numbers for *nnnnnnn*, or specify the value for the range in multiple DBRECDIST control statements. When specifying multiple DBRECDIST control statements, the statements do not need to be consecutive, but the value of the range must be in ascending order.

#### **Example of a normal case:**

```
DBRECDIST=(1,2,3,4)
OUTPUT=SYSUT3
DBRECDIST=5
DBRECDIST=(6,7,8,9,10)
```

#### **Example of an error case:**

```
DBRECDIST=(5,6,7,8,9,10)
DBRECDIST=(1,2,3,4)
```

This control statement is ignored for SHISAM databases.

## **DBRECKEYS control statement**

Specifies the number of the largest database records in the database to be listed in the Largest Database Records report.

This control statement is optional. The default is DBRECKEYS=10.

**Usage note:** This control statement is not available for the Unload task of the Smart Reorg utility. If the control statement is specified, it is ignored.

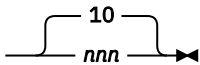
►► DBRECKEYS= 

### **nnn**

Specifies a left-aligned decimal number in the range of 0 - 999. The largest *nnn* database records in the database are listed in the Largest Database Records report. The default is 10. When DBRECKEYS=0 is specified, the report is suppressed.

## **DECODEDBD control statement**

Specifies whether to decode the DBD and print the resulting DBD source statements in the Decoded DBD report.

This control statement requires IMS Library Integrity Utilities. See [“Software prerequisites” on page 39](#).

This control statement is optional. The default is DECODEDBD=NO.

**Usage note:** This control statement is not available for the Unload task of the Smart Reorg utility. If the control statement is specified, it is ignored.

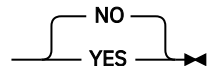
►► DECODEDBD= 

### **YES**

Specifies to decode the DBD.

## NO

Specifies not to decode the DBD.

For HIDAM databases, the DBDs for the primary database and the primary index are decoded.

**Tip:** You can change the default value of this control statement by creating an Installation Default Option Table (HPSCOPTI). For more information, see [Chapter 45, “Setting installation default options,”](#) on page 617.

## DECOMPRESS control statement

Specifies whether the database segments are to be decompressed (expanded) or not.

This statement activates or deactivates calling the segment compress routine for all segment types with COMPRTN specified on their related SEGM statements in the DBD.

If the HD-format unload data set is reloaded by the IPR Reload utility or IMS HP Load and the DBD has not been changed, the segment decompression is not necessary because each reload utility supports reloading of the compressed segments. The segments must be decompressed if any change is made to the DBD definitions, such as changes in compression routine or segment length.

This control statement is effective for all database segments with the COMPRTN= parameter specified on their related SEGM statements in the DBD. You cannot selectively activate or deactivate this option for a particular compressed segment.

This control statement is optional. The default is DECOMPRESS=NO.

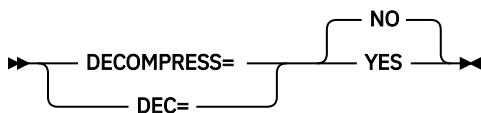

The abbreviation DEC= can be used for DECOMPRESS=.

## YES

Segments are decompressed if a compression routine is specified for the segments.

## NO

Segments are not decompressed even if a compression routine is specified for the segments.

### Notes:

- An unloaded data set created with the DECOMPRESS=NO option cannot be used as input for the IMS HD Reorganization Reload utility. If you use it, the reload job issues DFS388A and ends with a return code 16.
- If there is a segment type for which a segment edit/compression exit routine is specified and the use of the data conversion using a Data Conversion exit routine (DFSDBUX1) is designated, the DECOMPRESS=NO option is ignored and the process continues with DECOMPRESS=YES.
- If DECOMPRESS=NO option is specified and one or more partitions of PHDAM or PHIDAM are in a HALDB OLR cursor-active status, the IPR Unload utility ends abnormally.
- Do not code DECOMPRESS=NO if you want to change the size of the segments.

**Tip:** You can change the default value of this control statement by creating an Installation Default Option Table (HPSCOPTI). For more information, see [Chapter 45, “Setting installation default options,”](#) on page 617.

## FALLBACK control statement

Activates the fallback unload function to unload a database for migration from a partitioned database (PHIDAM or PHDAM database) to a nonpartitioned database (HIDAM or HDAM database).

**Usage note:** This control statement is not available for the Unload task of the Smart Reorg utility. If the control statement is specified, it is ignored.

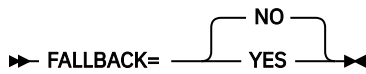

**NO**

Does not activate the fallback unload function.

**YES**

Activates the fallback unload function.

**Restrictions and requirements:**

- FALLBACK=YES cannot be specified with the PARTITION control statement or MIGRATE=YES.
- If FALLBACK=YES is specified, multiple OUTPUT control statements cannot be specified.
- If FALLBACK=YES is specified, the format of the unloaded data set, which you specify on the OUTPUT control statement, must be \*HD.
- The input database must be either a PHIDAM or a PHDAM database.

## HOMECHK control statement

Specifies whether to generate the HDAM Root Placement section in the HDAM Root Addressable Area Statistics report, and if so the location (the relative location of the database record assigned by the randomizer) to be printed under LOCATION.

This control statement is optional. The default is HOMECHK=(-10,+10).

**Usage note:** This control statement is not available for the Unload task of the Smart Reorg utility. If the control statement is specified, it is ignored.

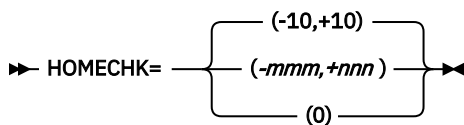

If you do not want to generate the HDAM Root Placement section, specify HOMECHK=(0). When specifying 0, you can omit the parentheses "()". That is, you can specify HOMECHK=0.

The HOMECHK control statement is valid only for an HDAM or a PHDAM database. If it is specified for other databases, it is ignored.

**mmm**

Specify the range of locations to be printed under LOCATION. For *mmm*, specify the lowest location before the home block (the home block is the block the root segment must be placed in, based on the randomizing routine) that you want to print. You can specify a 3-digit decimal number in the range of 1 - 998. The leading zero can be omitted.

**nnn**



Specify the range of locations to be printed under LOCATION. For *nnn*, specify the highest location after the home block that you want to print. You can specify a 3-digit decimal number in the range of 1 - 998. The leading zero can be omitted.

## ITKBLOAD control statement

Specifies the name of the load module library for IMS Tools KB.

This control statement is used only when ITKBSRVR=*servername* is specified. If you do not specify this control statement, ITKBLOAD=\*NO is used and IPR Unload utility attempts to load the IMS Tools KB module from the STEPLIB libraries.

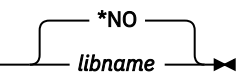
**Usage note:** This control statement is not available for the Unload task of the Smart Reorg utility. If the control statement is specified, it is ignored.

►► ITKBLOAD=  **libname** 

**\*NO**

The IMS Tools KB modules are loaded from the private library or the system library of the job.

**libname**

Specifies the name of the IMS Tools KB load module data set that is to be used by the IPR Unload utility.

**Requirement:** When all the STEPLIB libraries are APF-authorized, this library also needs to be APF-authorized.



**Tip:** You can change the default value of this control statement by creating an Installation Default Option Table (HPSCOPTI). For more information, see [Chapter 45, “Setting installation default options,” on page 617.](#)

## ITKBSRVR control statement

Specifies the name of the IMS Tools KB server XCF group.

This control statement is optional. The default is ITKBSRVR=\*NO.

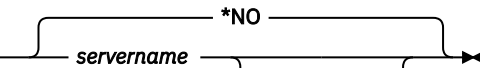
**Usage note:** This control statement is not available for the Unload task of the Smart Reorg utility. If the control statement is specified, it is ignored.

►► ITKBSRVR=  **servername** 

**\*NO**

IPR Unload utility does not store reports in the IMS Tool KB Output repository.

**servername**

IPR Unload utility stores reports in the IMS Tools KB Output repository of the specified server.

**ERRC04**

IPR Unload utility returns return code 4 when it encounters IMS Tools KB errors. If ERRC04 is not specified and an error is encountered in IMS Tools KB Output repository processing, the return code is 0.

If ITKBSRVR=*servername* is specified, IPR Unload utility attempts to connect to the server and then to store the following reports in the Output repository of IMS Tools KB:

- Environment
- HPSIN Control Statements
- DBD Summary
- HALDB Partitions Processed
- Segment Count Summary
- Segment Statistics
- HDAM Root Addressable Area Statistics
- HDAM RAP Chain I/O Summary report
- Distribution of Database Record Sizes
- HISAM Statistics
- Data Set Statistics
- HALDB Partition Definition
- Largest Database Records report

See Chapter 28, “IPR Unload reports,” on page 409 for a list of report names that are used in IMS Tools KB.

Several reports are not produced if STATREP=NO is specified. For details, see “STATREP control statement” on page 386.

**Requirement:** ITKBSRVR=*servername* requires that an appropriate version of IMS Tools KB is installed and the server is started. For more information, see “Software prerequisites” on page 39 and “Task 2: Completing configuration for IMS Tools Knowledge Base” on page 44.

**Tip:** You can change the default value of this control statement by creating an Installation Default Option Table (HPSCOPTI). For more information, see Chapter 45, “Setting installation default options,” on page 617.

## MIGRATE control statement

Activates the migration unload function to unload a database for migration from a nonpartitioned database (HIDAM or HDAM database) to a partitioned database (PHIDAM or PHDAM database).

**Usage note:** This control statement is not available for the Unload task of the Smart Reorg utility. If the control statement is specified, it is ignored.

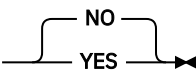
►► MIGRATE= 

### NO

Does not activate the migration unload function.

### YES

Activates the migration unload function.

### Restrictions and requirements:

- MIGRATE=YES cannot be specified with the PARTITION control statement or FALLBACK=YES.
- If MIGRATE=YES is specified, multiple OUTPUT control statements cannot be specified.
- If MIGRATE=YES is specified, the format of the unloaded data set, which you specify on the OUTPUT control statement, must be \*HD.
- The input database must be either a HIDAM or an HDAM database.
- If PTR=H or PTR=HB is defined as the parent segment of a virtual logical child, IPR Unload does not support the migration unload of the database.
- Migration unload of a secondary index or HISAM database is not supported.
- If a logical child is defined in the input database, and you want to improve the performance, code an appropriate number of IMS buffer pools in the DFSVSAMP DD.

## OUTPUT control statement

Specifies output characteristics of an IPR Unload utility job.

If you want to use a user exit routine, specify the routine name and the type of user exit interface (A or B).

**Recommendation:** The IPR Unload utility supports two types of user exit interface. Unless your user exit was used for the FABHFSU unload utility of IMS HP Unload, select the Type-B user exit interface by specifying OUTPUT=,(*rtname*,B). For more information, see Chapter 29, “User exits for IPR Unload,” on page 455.

If MIGRATE=YES or FALLBACK=YES is specified, multiple OUTPUT control statements cannot be specified.

This control statement is optional. The default is OUTPUT=SYSUT2,\*HD.

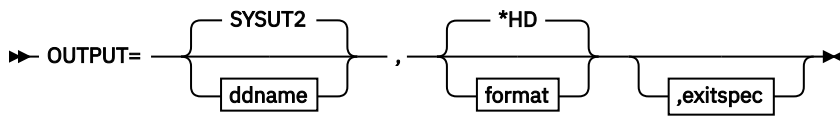

**ddname**

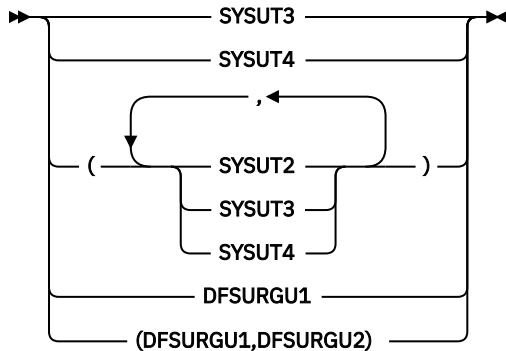

**format**

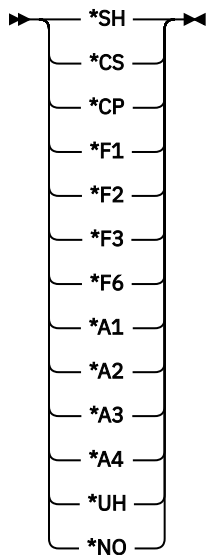

**exitspec**

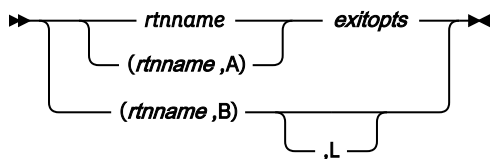

**ddname**

The first operand (*ddname*) of an OUTPUT statement specifies the DD name for the unload data set. The following DD names are allowed: SYSUT2, SYSUT3, and SYSUT4. DFSURGU1 and DFSURGU2 are also allowed.

You can specify multiple DD names as a list of DD names.

If no DD name is specified, the DD name of SYSUT2 or DFSURGU1 is assumed.

If an exit routine is specified in the OUTPUT statement, the segment data is edited by the exit routine and written to the data set identified by the DD name.



You can specify up to three DD names. If you specify more than one DD name, you must enclose the list of DD names with a pair of parentheses. For example:

```
OUTPUT=SYSUT2,*HD
OUTPUT=(SYSUT2,SYSUT3),*HD
OUTPUT=(SYSUT2,SYSUT3,SYSUT4),*HD
```

**Notes:**

- You can use the DFSURGU1 DD statement instead of the SYSUT2 DD statement. In this case, the unloaded segment records are written to the DFSURGU1 data set even if no OUTPUT control statement is specified.
- The DFSURGU2 DD statement is available only when the DFSURGU1 DD statement is used.
- You cannot specify *SYSUT $n$*  ( $n=2,3,4$ ) and *DFSURGU $n$*  ( $n=1,2$ ) together on the OUTPUT control statements.

**format**

Specifies one of the following unloaded data formats:

**\*HD**

The standard HD format. This format is usable as input to the IPR Reload utility or other reload utilities. If you reload the unloaded data set using the reload program other than the IPR Reload utility, see the notes that follow.

A HALDB unloaded by using the HD format is seen internally by the IPR Reload utility and IMS HP Load as the PHD format. It is referred to as the PHD format by the IPR Reload utility and IMS HP Load.

For more information about the compatibility with the unload data set created by IMS HD Reorganization Unload utility, see [“Considerations” on page 355](#).

**\*SH**

The short header format. This format is usable as input to the IPR Reload utility. This format is usable only if the database has no logical relationships.

**\*CS**

The communication industry standard format. This format is usable as input to the IPR Reload utility. This format is usable only if the database has no logical relationships.

If the database is a HALDB, this format can be used as input to the IPR Reload utility only if the database does not have any partitioned secondary index (PSINDEX) databases.

**\*CP**

The communication industry partitioned format. This format can be used as input to the IPR Reload utility. This format is useful if the database is a HALDB with partitioned secondary index (PSINDEX) databases. This format can be used only if the database is a HALDB and has no logical relationships.

**\*F1, \*F2, \*F3**

These formats are the same as those provided by the FABHURG1 unload utility of IMS HP Unload. For the detailed description of these formats, see the *IMS High Performance Unload User's Guide*. Formats \*F4 and \*F5 are not supported.

**\*F6**

See [“Unloaded data formats” on page 381](#).

**\*A1**

See [“Unloaded data formats” on page 381](#).

**\*A2**

See [“Unloaded data formats” on page 381](#).

**\*A3**

See [“Unloaded data formats” on page 381](#).

**\*A4**

See [“Unloaded data formats” on page 381](#).

**\*UH**

The user-defined header format. You must specify the USERHDR control statement together to define the header format. For more information, see [“USERHDR control statement”](#) on page 387.

**\*NO**

No output data set is created.

**Notes:**

- The compressed segments are not decompressed by default when the segments are retrieved from the database. Thus, if you need the segments to be decompressed for your program that reads the unloaded data set, you must specify the DECOMPRESS=YES control statement.
- If an unloaded HALDB is to be loaded by using the IPR Reload utility or IMS HP Load, the unload format \*HD must be used.
- If the \*CS format for PHDAM or \*A1 format is specified and one or more partitions of PHDAM or PHIDAM are in the HALDB OLR cursor-active status, the IPR Unload utility ends abnormally.

**exitspec**

Specifies the name (*rtname*), type (A or B), and options (*exitopts*) of the user exit routine that is to be called.

The following types of user exit are supported:

- Type-A user exit

The default user exit interface, which is compatible with the FABHFSU unload utility of IMS HP Unload

- Type-B user exit

User exit simpler than Type-A.

For details of the call interface of each user exit, see [Chapter 29, “User exits for IPR Unload,”](#) on page 455.

**Type-A User Exit**

A Type-A exit routine can be specified by coding the routine name *rtname*, or the routine name and the exit type of A: (*rtname,A*). You can also specify the processing options (*exitopts*) for a Type-A exit routine.

The specification of *exitopts* is as follows:

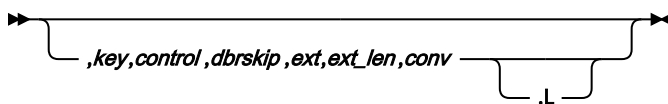

Each processing option is as follows:

**key**

Specifies whether the fully concatenated key of each segment is to be built and passed to the user exit routine or not.

**YES**

Builds the concatenated key.

**NO**

Does not build the concatenated key. NO is the default.

**control**

Specifies whether the user exit routine is given control before and after segments are processed or not.

**YES**

Allows the exit routine control.

**NO**

Does not allow the exit routine control. NO is the default.

***dbrskip***

Specifies whether return code 12 or 16 is valid for the exit routine or not. If valid, a return code 12 causes the IPR Unload utility to skip the remaining segments associated with the current root segment and begin processing at the next root segment. Return code 16 causes a skip to a new root key value specified by the exit routine.

**YES**

Allows the database record skip option.

**NO**

Does not allow the database record skip option. NO is the default.

***ext***

Specifies whether segments are modified and the lengths of the segments are extended by the user exit routine or not.

**YES**

Indicates that segments are modified by the user exit and the lengths of segments are extended.

Specify this option if the length of a fixed-length segment or the maximum size of a variable-length segment is to be modified. If the segment length is extended by the change, it is your responsibility to initialize the additional area with the user exit.

By this option, an extra 100-byte field is added at the end of the segment data passed to the user exit routine. This additional area can be used for segment extension. If the default length of this extra field is shorter than you require, you can change the length by specifying the *ext\_len* operand.

If you want to modify the content of segments but the segment length is to be remained unchanged, specify NO.

If this option has been selected, the IPR Unload utility ignores any request to activate the compare options invoked by the following specifications:

- COMPAREDLI control statement
- SYSUT1 DD statement

**NO**

Indicates that the lengths of segments are not modified. NO is the default.

***ext\_len***

A 1-to-5-digit numeric value that specifies the length of the extra bytes to be reserved for the segment extension in the user exit routine. The length specified on this field plus the maximum length of the segments in the database is used as the length of the work area for editing segments in the user exit routine. This field can be valid only if YES is specified for the *ext* option of the OUTPUT statement. The default value of 100 is used if YES is specified for the *ext* option and this field is left blank.

You can specify a value in the range of 1 - 32767.

**Note:** If the resulting length of the segment editing work area is longer than 32,767 bytes, 32,767 is used as the length of the work area. If YES is not specified for the *ext* option, the value specified on this field is ignored.

***conv***

If an IMS Data Conversion exit routine is used, the user exit routine receives the segment data that have been converted reversibly from a database image to an application image.

**YES**

Allows the segment data edited in the exit routine to be converted forward from an application image to a database image before the data is written into the output data set.

This option is valid only if the DATXEXIT=YES option (see “[DATXEXIT control statement](#)” on page 398) is specified, and only for the HD and SH unload formats.

**NO**

Indicates that the forward conversion is not done before the data is written into the output data set. NO is the default.

**L**

Language environment option. Indicates that the user exit routine runs in the Language Environment® (LE) using the CEEPIPI invocation.

This option is effective when the user exit routine is written with Enterprise COBOL for z/OS. This option is not effective for user exit routines written in assembly language or PL/I.

This option is mutually exclusive with the RTEXTIT control statement. If you specify this option, the runtime environment exit routine specified for the RTEXTIT control statement is not invoked.

If the same exit routine name is specified on more than one OUTPUT control statement at a time, a single copy of the exit routine is loaded and called—it does not mean that the specified numbers of copies are loaded and called independently.

The following are examples of specifying a Type-A exit routine:

```
OUTPUT=SYSUT2,*HD,MYEXIT,Y,,Y
OUTPUT=SYSUT2,*HD,(MYEXIT,A),Y,Y,Y
OUTPUT=SYSUT2,,COBEXIT,Y,Y,Y,Y,,L
```

**Type-B User Exit**

The *exitspec* for a Type-B user exit routine must be specified as: (*rtnname*,B). The *rtnname* subparameter specifies the program name of the exit routine; the second subparameter B specifies that the routine is a Type-B exit routine.

If a Type-B user exit routine is specified in an OUTPUT control statement, no other OUTPUT statement can be specified. The following processing option can be specified:

**L**

Language environment option. Indicates that the user exit routine runs in the Language Environment (LE) using the CEEPIPI invocation.

This option is effective when the user exit routine is written with Enterprise COBOL for z/OS. This option is not effective for user exit routines written in assembly language or PL/I.

This option is mutually exclusive with the RTEXTIT control statement. If you specify this option, the runtime environment exit routine specified for the RTEXTIT control statement is not invoked.

The following are examples of specifying a Type-B exit routine:

```
OUTPUT=SYSUT2,*HD,(MYEXIT,B)
OUTPUT=SYSUT2,*HD,(MYEXITC,B),L
```

**Notes:**

- You can specify more than one OUTPUT control statement in your JCL stream. Do not, however, specify the same DD name more than once throughout the OUTPUT control statements. In other words, the maximum number of OUTPUT statements that you can specify in your JCL stream is three.
- Combine multiple OUTPUT statements with the same Type-A exit routine name and exit processing options into a single OUTPUT statement. For example, combine the following statements:

```
OUTPUT=SYSUT2,*HD,EXIT01
OUTPUT=SYSUT3,*HD,EXIT01
```

to:

```
OUTPUT=(SYSUT2 ,SYSUT3) , *HD ,EXIT01
```

- If a user exit routine is specified and one or more partitions of PHDAM or PHIMDA are in the HALDB OLR cursor-active status, IPR Unload utility ends abnormally.

## Unloaded data formats

In this topic, details of the unloaded data formats F6, A1, A2, A3, and A4 are described.

PSPI

These are product-sensitive programming interfaces. See “Programming interface information” on page 804 to understand the restrictions associated with this type of material.

### F6 format

This topic describes F6 format. It is a product-sensitive programming interface. See “Programming interface information” on page 804 to understand the restriction associated with this type of material.

The following figure shows the F6 format.

FORMAT OF F6 RECORDS					
STATEMENT		OFFSET		DESCRIPTION	
		DEC	HEX		
REC6	DSECT				
REC6LEN	DC	H'0'	0	0	RECORD LENGTH FIELD
REC6ZZ	DC	H'0'	2	2	ZZ (RESERVED FOR MVS)
REC6HL	DC	H'0'	4	4	HEADER LENGTH
REC6DBD	DC	CL8' '	6	6	DBD NAME
REC6SGN	DC	CL8' '	14	E	SEGMENT NAME
REC6SGL	DC	X'00'	22	16	SEGMENT LEVEL
REC6KEYL	DC	XL2'00'	23	17	KEY LENGTH
REC6RKEY	EQU	*	25	18	ROOT SEQUENCE KEY
REC6DATA	EQU	*	25	18	SEGM DATA AS RETURNED BY IPR UNLOAD

Figure 132. F6 format

This format is to be used for processing by application programs. If you use the F6 format, a variable-length record is written for each retrieved database segment and the record contains the following data fields:

- Length of the header (REC6HL), which is the length of the fields from REC6HL to REC6RKEY both inclusive
- DBD name (REC6DBD)
- Segment name (REC6SGN)
- Segment level (REC6SGL)
- Length of segment's sequence field (REC6KEYL)
- Sequence key of the root segment (REC6RKEY)
- Segment data as returned by the IPR Unload utility (REC6DATA)

#### Notes:

- The unload data set contains no header record and trailer record.
- If the segment has no sequence key field, binary zeros are set in the REC6KEYL field.
- If the root segment has no sequence field, the length of REC6RKEY is zero.
- If you use an exit routine,
  - You must not change the length of the sequence field for each segment.

- You must not change the start position and the length of the sequence field of the root segments.
- However,
- You can change the value of the sequence field of the root segments.
  - You can change the starting position of the sequence field of the dependent segments.

## A2 format

The following figure shows the A2 format.

FORMAT OF A2 RECORDS					
STATEMENT		OFFSET			DESCRIPTION
		DEC	HEX		
RECA2	DSECT				
RECA2LEN	DC	H'0'	0	0	RECORD LENGTH FIELD
RECA2ZZ	DC	H'0'	2	2	ZZ (RESERVED FOR MVS)
RECA2SNM	DC	CL8' '	4	4	SEGMENT NAME
RECA2FLG	DC	XL1'00'	12	C	SEGMENT FLAG
RECA2DAT	EQU	*	13	D	SEGM DATA AS RETURNED BY IPR UNLOAD

Figure 133. A2 format

This format is to be used for processing by application programs. If you use the A2 format, a variable-length record is written for each retrieved database segment and the record contains the following data fields:

- Segment name (RECA2SNM)
- Segment flag (RECA2FLG), which is always zero

**Note:** The unload data set contains no header record or trailer record.

## A3 format

The following figure shows the A3 format.

FORMAT OF A3 RECORDS					
STATEMENT		OFFSET			DESCRIPTION
		DEC	HEX		
RECA3	DSECT				
RECA3LEN	DC	H'0'	0	0	RECORD LENGTH FIELD
RECA3ZZ	DC	H'0'	2	2	ZZ (RESERVED FOR MVS)
RECA3SCD	DC	XL1'00'	4	4	SEGMENT CODE
RECA3SLV	DC	XL1'00'	5	5	SEGMENT LEVEL
RECA3SGL	DC	H'0'	6	6	SEGMENT LENGTH
RECA3DAT	EQU	*	8	8	SEGM DATA AS RETURNED BY IPR UNLOAD

Figure 134. A3 format

This format is to be used for processing by application programs. If you use the A3 format, a variable-length record is written for each retrieved database segment and the record contains the following data fields:

- Segment code (RECA3SCD)
- Segment level (RECA3SLV)
- Segment length as returned by the IPR Unload utility (RECA3SGL)

**Notes:**

- The unload data set contains both the header record and trailer record, which are indicated by the segment code (RECA3SCD) of binary zeros.

- The header record is compatible with IMS HD Unload.
- The trailer record is compatible with \*HD.
- RECA3SGL is the length of the data that starts from RECA3DAT.

## A4 format

The following figure shows the A4 format.

FORMAT OF A4 RECORDS					
STATEMENT	DSECT		OFFSET		DESCRIPTION
			DEC	HEX	
RECA4	DSECT				
RECA4LEN	DC	H'0'	0	0	RECORD LENGTH FIELD
RECA4ZZ	DC	H'0'	2	2	ZZ (RESERVED FOR MVS)
RECA4SCD	DC	XL1'00'	4	4	SEGMENT CODE
RECA4HDF	DC	XL1'00'	5	5	HSAM DELETE FLAG
RECA4HLN	DC	H'0'	6	6	HEADER LENGTH
RECA4SGL	DC	H'0'	8	8	SEGMENT LENGTH
RECA4SNM	DC	CL8' '	10	A	SEGMENT NAME
RECA4SDB	DC	XL1'00'	18	12	SEGMENT DELETE BYTE
RECA4DAT	EQU	*	19	13	SEGM DATA AS RETURNED BY IPR UNLOAD

Figure 135. A4 format

This format is to be used for processing by application programs. If you use the A4 format, a variable-length record is written for each retrieved database segment and the record contains the following data fields:

- Segment code (RECA4SCD)
- HSAM delete flag used by IMS (RECA4HDF)
- Length of header (RECA4HLN)
- Segment length as returned by the IPR Unload utility (RECA4SGL)
- Segment name (RECA4SNM)
- Segment delete byte in the segment prefix (RECA4SDB)

### Notes:

- The unload data set contains both the header record and trailer record, which are indicated by the segment code (RECA4SCD) of binary zeros.
- The header record is compatible with IMS HD Unload.
- The trailer record is compatible with \*HD.
- RECA4SGL is the length of the data that starts from RECA4DAT.



## PARTITION control statement

Specifies which HALDB partitions are to be unloaded.

This control statement is optional. The default is PARTITION=\*ALL.

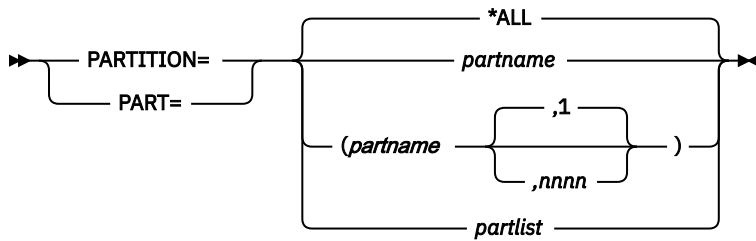

**\*ALL**

Unloads all the partitions at the same time (entire database unload).

**partname**

Specifies the name of a partition or the first partition of several sequential partitions to be unloaded.

**nnnn**

Specifies the number of sequential partitions to be unloaded. The unloading order of the partitions depends on either the HALDB partition selection exit routine or the HALDB high key values, and not on the partition names. If this parameter is not specified, the default value of 1 is assumed.

The following statements have the same meaning:

- PARTITION=PARTA
- PARTITION=(PARTA)
- PARTITION=(PARTA,1)

When you specify two or more partitions, be careful with the sequence in which the partitions are processed. The sequence is determined by the HALDB partition selection exit routine or the HALDB high key values, and not by the partition names.

**partlist**

Specifies a list of the partition names to be unloaded. The names must be separated by commas and enclosed in parentheses. You can specify up to 1001 names separated into multiple statement as follows:

```
PARTITION=(part1,part2,part3,part4,part5)
PARTITION=(part6,part7,part8,part9,part10)
```

The unloading order of the partitions depends on this list, not on the HALDB partition selection exit routine or the HALDB high key values. You can specify non-sequential partitions.

If PARTITION=partlist is specified and one or more partitions of PHDAM or PHIDAM are in a HALDB OLR cursor-active status, the IPR Unload utility ends abnormally.

**Usage notes:**

- This control statement cannot be specified with the MIGRATE=YES or FALLBACK=YES control statement.
- For a Smart Reorg job, you can specify the PARTITION control statement in the (REORG) block but not in the (UNLOAD) block. For more information about the PARTITION control statement for the (REORG) block, see [“PARTITION control statement” on page 150.](#)

**PROGMON control statement**

Specifies whether to monitor the progress of the Unload task.

The progress monitoring message HPSU3280I is issued at the specified intervals.

This control statement is optional. The default is PROGMON=0.

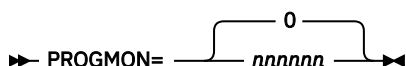



When PROGMON=0 is specified, one progress monitoring message is issued at the end of a database process or at each partition process.

**nnnnnn**

Specifies a left-aligned decimal number in the range of 0 - 999999. After every *nnnnnn* database records are processed, the IPR Unload utility issues a progress monitoring message.

## RAPCHECK control statement

Specifies to check whether each root segment of HDAM/PHDAM database is chained off from the correct RAP.

This control statement is optional. The default is RAPCHECK=NO.

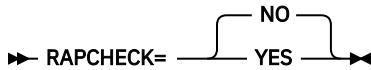

The RAPCHECK statement specifies to check whether each root segment of HDAM/PHDAM database is chained off from the correct RAP. If RAPCHECK=YES is specified, the RAPCHECK routine (HPSURPCX) is called as the user exit routine. It calls the randomizer module for each root segment with its key, and it compares the assigned RAP RBA with the currently chained RAP RBA.

The result of the check is shown in WTO messages HPSU3170I or HPSU3171W. If one or more incorrect RAPs are detected, the HDAM RAPCHECK Incorrect RAP Chain report is generated in the HPSRAPC data set.

**NO**

Deactivates the RAPCHECK option.

**YES**

Activates the RAPCHECK option.

**Notes:**

- The only performance impact is that extra CPU is needed for the check. The database I/O will not be delayed.
- If RAPCHECK=YES is specified, the OUTPUT control statement cannot be specified because the following statement is generated internally:

```
OUTPUT=SYSUT2, *HD, HPSURPCX, NO, YES
```

## SEGSEL control statement

Specifies one or more segment names to be unloaded selectively.

This control statement is optional. The default is SEGSEL=\*ALL.

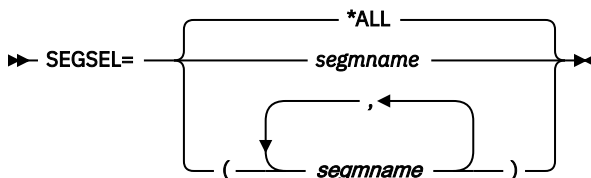

**\*ALL**

Unloads all the segments that are defined in the specified DBD.

**segmname**

Specifies the segment name to be unloaded. Two or more segment names must be separated by commas and enclosed in parentheses. You can specify up to 255 segment names separated into multiple statements.

When specifying two or more statements, specify them as follows:

```
SEGSEL=(rootseg,depseg1,depseg2,depseg3,depseg4)
SEGSEL=(depseg6,depseg7,depseg8,depseg9,depseg10)
```

You can see the number of the unloaded segment occurrences in the Segment Count Summary report. For the segment that was not specified on the SEGSEL control statement, 'O' is shown in the UNLOADED field and 'N/A' is shown in the DELETED BY USER EXIT field, even if a user exit is specified.

#### Notes:

- Virtual logical child segments cannot be specified.
- If the hierarchical relationships of existing segments are changed by deleting some segments, you cannot use the unloaded data set as input to IMS HD Reorganization Reload utility (DFSURGL0) or its compatible utilities.

## SKIPAUTH control statement

Specifies whether to bypass IMS DBRC database authorization to avoid DBRC authorization failure (DFS047A). This control statement is used only when DBRC is active.

This control statement is optional. The default is SKIPAUTH=NO.

**Usage note:** This control statement is not available for the Unload task of the Smart Reorg utility. If the control statement is specified, it is ignored.

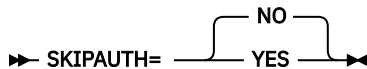

#### YES

A database authorization request is not sent to IMS DBRC.

#### NO

A database authorization request is sent to IMS DBRC before opening each database or partition.

When SKIPAUTH=YES is specified, you can run the IPR Unload utility without issuing an IMS /DBDUMP command to the database. In this case, no read integrity is provided.

## STATREP control statement

Specifies that certain statistics reports are not printed.

This control statement is optional. The default is STATREP=YES.

**Usage note:** This control statement is not available for the Unload task of the Smart Reorg utility. If the control statement is specified, it is ignored.

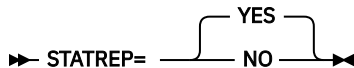

#### NO

The following reports are not printed. CPU time is reduced by suppressing them.

- Segment Statistics report
- Distribution of Database Record Sizes report
- Largest Database Records report
- Data Set Statistics report
- HDAM Root Addressable Area Statistics report
- HISAM Statistics report

Even if DBSTATS=YES is specified, the following reports are also suppressed:

- HDAM RAP Chain I/O Summary report

- DB Statistics report

The format of the Segment Count Summary report is the same as that generated in the Smart Reorg utility.

## YES

The statistics reports in the list are printed depending on other control statements.

**Tip:** You can change the default value of this control statement by creating an Installation Default Option Table (HPSCOPTI). For more information, see [Chapter 45, “Setting installation default options,”](#) on page 617.

## USERHDR control statement

Specifies the list of the elements to be stored in the header portion of the \*UH unload format record.

To use the \*UH format, you must specify \*UH on one or more OUTPUT statements together.

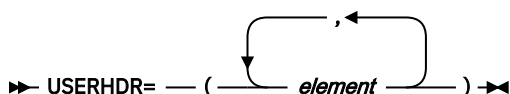

Specify a list of the elements to be stored in the header portion of each unload record in the \*UH format. You can select up to 22 elements from [Table 46 on page 388](#) in multiple statements as shown in [Example 2](#).

**Note:** The \*UH format unload data set can become the input for the IPR Reload utility by keeping the following rules:

- SEGNAME or SEGCODE must be included.
- If you specify one or more elements with variable length such as SEGCKEY, SEGKEY, and ROOTKEY, HDRLEN must be included ahead of the variable length elements. SEGNAME or SEGCODE must also precede them.

The IPR Reload utility, however, does not support to reload a non-HALDB with logical relationships or a HALDB.

### Example 1

The following control statements are assumed:

```
OUTPUT=SYSUT2,*UH
USERHDR=(HDRLEN,SEGNAME,ROOTKEY)
```

The variable-length records shown in the following figure are put to the SYSUT2 data set.

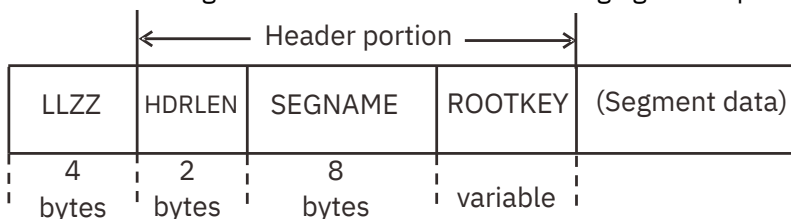

Figure 136. Example record format of the USERHDR control statement

The HDRLEN element contains the length of the header portion and the value can be used to get the length of the root key and the starting position of the segment data.

### Example 2

The following control statements are assumed:

```
OUTPUT=SYSUT2,*UH
USERHDR=(HDRLEN,DBDNAME,SEGNAME,SEGLEV1)
USERHDR=(SEGKEYSZ,ROOTKEY,FILLER08)
```

The list of the elements is separated into two statements, and seven elements are stored in the header portion of each unload record. The last 8 bytes in the header portion are filled with binary zeros.

Table 46. The elements supported by USERHDR control statement

Element name	Length (bytes)	Type	Description
DBDNAME	8	Character	DBD name
FILLER $nn$	$nn$	Hex	This field is filled with binary zeros. Suffix $nn$ is the length and it must be replaced by a 2-digit decimal number in the range of 00 - 99.
FLAG	1	Flag byte	Flag byte X'80': Compressed form
HDRLLEN	2	Hex	Length of the header portion. (See <a href="#">Note 1</a> )
ROOTKEY	Variable	-	Sequence key of the root segment. The length is variable. (See <a href="#">Note 2</a> )
ROOTRBA	4	Hex	RBA of the root segment. (See <a href="#">Note 3</a> )
SEGCKEY	Variable	-	Concatenated key of the segment. The length is variable and is contained in SEGCKYSZ. (See <a href="#">Note 2</a> )
SEGCKYSZ	2	Hex	Length of the concatenated key of the segment.
SEGCODE	1	Hex	Segment code
SEGDATSZ	2	Hex	Length of the data portion of the segment.
SEGDBYTE	1	Flag byte	The delete flag of the segment. (See <a href="#">Note 4</a> )
SEGKEY	Variable	-	Sequence key of the segment. The length is variable and is contained in SEGKEYSZ. (See <a href="#">Note 2</a> )
SEGKEYOF	2	Hex	Offset of the sequence key in the data portion of the segment. (See <a href="#">Note 5</a> )
SEGKEYSZ	2	Hex	Length of the sequence key of the segment. (See <a href="#">Note 5</a> )
SEGLEV1	1	Hex	Segment level
SEGLEV2	2	Character	Segment level
SEGNAME	8	Character	Segment name
SEGRBA	4	Hex	RBA of the segment (See <a href="#">Note 3</a> )

---

Table 46. The elements supported by USERHDR control statement (continued)

---

Element name	Length (bytes)	Type	Description
--------------	-------------------	------	-------------

---

**Notes:**

1. It is recommended that you put this element ahead of any element with variable length to recognize the position of the segment data.
  2. If the sequence key is undefined or compressed, no value is set and the length is zero.
  3. For HISAM database, binary zeros are filled.
  4. The bit indicating the segment split (bit 4) is always off. If a segment is involved in a logical relationship and the physical delete bit (bit 5) or the logical delete bit (bit 6) is turned on in an occurrence of the segment, the occurrence and its dependent occurrences are not unloaded in the \*UH format.
  5. If the sequence key is undefined or compressed, binary zeros are filled.
- 

## Control statements for HSSR Engine

---

HSSR (High Speed Sequential Retrieval) Engine is a software component, of IMS HP Unload, that provides the infrastructure for the high-performance retrieval of segments from IMS full-function databases.

HSSR Engine provides the following five major functions:

- Analyzing database calls issued from an HSSR application program
- Retrieving requested segments
- Buffering blocks or control intervals (CIs) of databases
- Tracing the database calls
- Providing diagnostics for errors in the database calls

HSSR Engine consists of the following components:

- Call Analyzer and Call Handler

Analyzes databases and retrieves segments from the database.

- Buffer Handler

Buffers blocks or control intervals (CIs) of the database.

- Statistics Facility

Produces statistics reports.

- Trace Facility

Takes trace of database calls processed by HSSR Engine.

- Diagnosis Facility

Provides diagnostics for database errors found in database calls.

Table 47 on page 390 through Table 52 on page 392 show control statements that can be specified to control HSSR Engine.

Table 47. Control statements for Call Analyzer and Call Handler

Keyword	Acceptable values	Default	Description
BLDLPCK	YES or NO	NO	Specifies whether to retrieve logical parent's concatenated keys (LPCKs) or not. See <a href="#">“BLDLPCK control statement”</a> on page 392.
BYINDEX	YES or NO	NO	Specifies whether to unload HIDAM or PHIDAM root segments through the primary index or not. See <a href="#">“BYINDEX control statement”</a> on page 395.
CABBASE	(See <a href="#">“CABBASE control statement”</a> on page 396.)	(No default)	Specifies the basic buffer size for CAB. See <a href="#">“CABBASE control statement”</a> on page 396.
COMPAREDLI	YES or NO	NO	Specifies whether to compare with the DL/I call result or not. See <a href="#">“COMPAREDLI control statement”</a> on page 397.
COMPAUTH	YES or NO	NO	Specifies whether to call the segment compression exit in supervisor state. See <a href="#">“COMPAUTH control statement”</a> on page 398.
DATXEXIT	YES or NO	NO	Specifies whether the Data Conversion exit routine is to be activated or not. See <a href="#">“DATXEXIT control statement”</a> on page 398.
KEYCHECK	NO ABEND GG GX	NO	Specifies whether to perform sequential key check or not. See <a href="#">“KEYCHECK control statement”</a> on page 400.
SKIPERROR	0 - 999999999	0	Sets error skip count. See <a href="#">“SKIPERROR control statement”</a> on page 402.
ZIIPMODE	NEVER or COND	NEVER	Specifies whether to offload eligible workloads to zIIP processors. See <a href="#">“ZIIPMODE control statement”</a> on page 404.

Table 48. Control statements for Buffer Handler

Keyword	Acceptable values	Default	Description
BUFFERS	(See <a href="#">“BUFFERS control statement”</a> on page 392)	*ALL,,8,,100, YES,YES	Sets the buffer specifications. See <a href="#">“BUFFERS control statement”</a> on page 392.

Table 49. Control statements for Statistics Facility

Keyword	Acceptable values	Default	Description
BUFSTAT	YES or NO	NO	Provides buffering statistics. See <a href="#">“BUFSTAT control statement”</a> on page 395.
DBSTATS	(See <a href="#">“DBSTATS control statement”</a> on page 398)	NO	Provides database statistics. See <a href="#">“DBSTATS control statement”</a> on page 398.
LOUT	YES, <i>length</i> , <i>nn</i> , or NO	NO	Provides information of each database record in the HPSLOUT data set. See <a href="#">“LOUT control statement”</a> on page 400.
PARTINFO	YES or NO	YES	Produces a HALDB Partition Definition report. See <a href="#">“PARTINFO control statement”</a> on page 401.
PARTSTAT	YES or NO	YES	Produces statistics report for each partition. See <a href="#">“PARTSTAT control statement”</a> on page 401.

Table 50. Control statements for Trace Facility

Keyword	Acceptable values	Default	Description
TRACE	(See <a href="#">“TRACE control statement”</a> on page 403)	(No default)	Generates trace information. See <a href="#">“TRACE control statement”</a> on page 403.

Table 51. Control statements for Diagnosis Facility

Keyword	Acceptable values	Default	Description
DIAGG	(See <a href="#">“DIAGG control statement”</a> on page 399)	NO	Generates diagnosis information for status GG. See <a href="#">“DIAGG control statement”</a> on page 399.

Table 52. Control statements for setting up runtime environment

Keyword	Acceptable values	Default	Description
RTEXTIT	<i>exitname</i>	HPSURTEX	Specifies the name of runtime exit routine. See “RTEXTIT control statement” on page 402.

## BLDLPCK control statement

Specifies whether to retrieve logical parent's concatenated keys (LPCKs) or not.

For a logical child segment with a logical parent's concatenated key (LPCK) that is specified as "virtual" on the SEGM statement of the DBD, HSSR Call Handler returns, by default, blanks in the I/O area that would typically hold the LPCK. You can use the BLDLPCK control statement to have HSSR Call Handler build the LPCK and return it in the I/O area.

This control statement is optional. The default is BLDLPCK=NO.

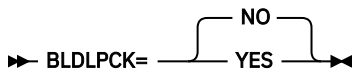

### NO

Bypass LPCK retrieval.

### YES

Retrieve logical parent's concatenated keys (LPCKs).

### Notes:

- If the LPCK is defined as "physical" (that is, the LPCK is physically stored as a part of the logical child segment in the database), the IPR Unload utility ignores this option.
- If BLDLPCK=YES is specified and there are a large number of virtual LPCK's in the database, the performance of the IPR Unload utility could be degraded. BLDLPCK=YES is necessary, however, if the control statements for the IMS Database Preorganization utility specified the DBIL for the logical child database to be unloaded by the IPR Unload utility. If the DBIL is specified for the database, symbolic keys in the unloaded database are used to match the logical children and the parents.
- If BLDLPCK=YES is specified for a database that has a logical child whose LPCK is defined as "virtual," the database data sets for all logical parent databases of such logical children must be specified on the JCL statement, or the MDA members must reside in a STEPLIB library. If any logical parent database cannot be allocated, an abend occurs in HSSR Engine.
- BLDLPCK statement is not supported for HISAM databases.
- BLDLPCK statement is ignored for PHDAM or PHIDAM databases.
- BLDLPCK statement is ignored if MIGRATE=YES or FALLBACK=YES control statement is specified.
- If APISET=3 is specified, the BLDLPCK statement is ignored and BLDLPCK=YES is always assumed.

**Tip:** You can change the default value of this control statement by creating an Installation Default Option Table (HPSCOPTI). For more information, see [Chapter 45, “Setting installation default options,”](#) on page 617.

## BUFFERS control statement

Specifies the number of database buffers that are used for each database data set group when reading the database.

This control statement is optional. The default is BUFFERS=\*ALL,,8,,100,YES,YES.



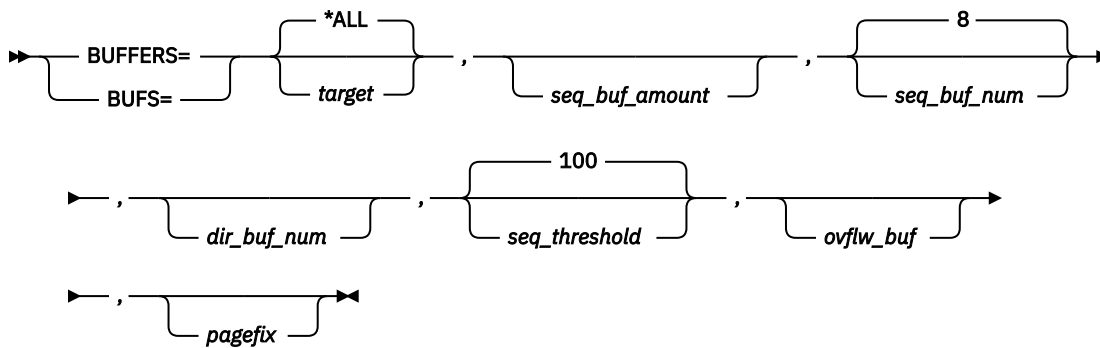

The size of a database buffer is almost the same as the CI or block size of the database data set group. The total number of database buffers is the sum of the buffers in the buffer pools each of which is allocated for a data set group and is used exclusively by the data set group.

The BUFFERS control statement applies only to ESDS, OSAM LDS, and OSAM data sets. KSDS buffering is done by VSAM, not by HSSR Engine. For a HALDB, a buffer pool is allocated for each data set group and each buffer pool is shared by all partitions.

There is no need to code a BUFFERS statement in most cases because buffering parameters that can be specified by the BUFFERS statement are automatically tuned and optimized for the input database. For severely fragmented databases, however, allocating more buffers than the default could improve the performance of your job. In those cases, code the BUFFERS control statement.

The abbreviation BUFS= can be used for BUFFERS=.

#### **target**

Indicates that the BUFFERS statement is effective for the data set or the set of data sets that is identified by *ddname*.

This parameter can be specified in one of the following ways:

- A keyword: \*ALL, \*HD, or \*PHD
- A DD name: *ddname*
- A pattern of DD names: '*pattern*'

#### **\*ALL**

Specifies that the statement applies to all ESDS, OSAM LDS, or OSAM data sets. \*ALL is the default.

#### **\*HD**

Specifies that the statement applies to all ESDS, OSAM LDS, or OSAM data sets of all HIDAM and HDAM databases.

#### **\*PHD**

Specifies that the statement applies to all ESDS, OSAM LDS, or OSAM data sets of all PHIDAM and PHDAM databases.

#### **\*HS**

Specifies that the statement applies to all ESDS data sets of all HISAM databases.

#### ***ddname***

Specifies that the statement applies to the data set identified by the specified DD name *ddname*.

#### **'*pattern*'**

Specifies that the statement applies to the data sets whose DD names match the wild-card string pattern.

*pattern* is a string of alphanumeric characters, including wild-card characters. You can use two kinds of wild-card character: an asterisk (\*) and the percent (%). An asterisk is interpreted as a sequence of 0 to 8 characters; and, a percent symbol is interpreted as a single character. If two or more asterisks are specified sequentially, only the first one is recognized. You cannot specify asterisks and the percent symbols simultaneously.

*pattern* must be enclosed by single quotation marks.

**Example:**

```
BUFFERS=' PART , , 10 , 100 , YES , NO
```

***seq\_buf\_amount***

Specifies the number of buffer slots allocated for a sequential buffer—that is, the number of OSAM blocks, OSAM LDS CIs, or ESDS CIs that are read together in a single sequential read.

The acceptable value is in the range of 2 - 255.

The default value is determined internally depending on the size of the OSAM block, OSAM LDS CI, or the ESDS CI.

***seq\_buf\_num***

Specifies the number of sequential buffers.

The acceptable value is in the range of 3 - 9999.

The default value is 8.

***dir\_buf\_num***

Specifies the number of direct buffers. An OSAM block, OSAM LDS CI, or an ESDS CI is read into a direct buffer by a direct read.

The acceptable value is in the range of 3 - 255.

The default value is determined internally from the *seq\_buf\_amount* value.

***seq\_threshold***

Specifies the reference threshold value for determining whether chained sequential I/O or direct I/O must be performed. The value must be specified by the percentage of the value specified for *seq\_buf\_amount*.

The acceptable value is in the range of 1 - 200.

The default value is 100 (%).

***ovflw\_buf***

Specifies how the overflow area of the primary data set group of an HDAM database or the overflow area of the primary data set group of each partition of a PHDAM database must be buffered.

**YES**

Indicates that the overflow area uses its own buffers. YES is the default.

**NO**

Indicates that the overflow area shares the buffers with the root addressable area.

**Notes:**

- This option affects the buffering efficiency for the prime data set group of an HDAM database or of the prime data set groups of a PHDAM database; especially, it affects both the size of the buffer space and the elapsed time.
- The same *ovflw\_buf* option must be specified for each partition of the PHDAM database.

***pagefix***

Specifies if the buffers are page-fixed or not. By default, buffers are page-fixed. To avoid page-fixing, you can use this parameter.

The same *ovflw\_buf* option must be specified for each partition of the PHDAM database.

**YES**

Indicates that buffers are page-fixed. YES is the default

**NO**

Indicates that buffers are not page-fixed.

The buffer handler requires a large number of buffers. When the buffers are not page-fixed, a noticeable amount of paging might occur.

**Note:** *pagefix* option must be identical among all data sets that belong to the same data set group.

The following table shows the correspondences between the parameters of the BUFFERS control statements and the HSSRCABP control statements of IMS HP Unload except for the *pagefix* parameter. For details of the tuning buffer handler, see the topic "Overview of the buffer handlers" in the *IMS High Performance Unload User's Guide*.

Table 53. Parameters for BUFFERS control statement and HSSRCABP control statements

Parameter of BUFFERS control statement	Corresponding HSSRCABP control statement
<i>target</i>	CABDD <i>target</i>
<i>seq_buf_amount</i>	RANSIZE <i>seq_buf_amount</i>
<i>seq_buf_num</i>	NBRSRAN <i>seq_buf_num</i>
<i>dir_buf_num</i>	NBRDBUF <i>dir_buf_num</i>
<i>seq_threshold</i>	REFT4 <i>n n</i> = $seq\_buf\_amount \times seq\_threshold / 100$ (Fractions below decimal point are rounded up to one.)
Not applicable	OVERFLOW BB
<i>ovflw_buf</i> = Y	OVERFLOW CAB
<i>ovflw_buf</i> = N	OVERFLOW SHR
<i>pagefix</i>	(IMS HP Unload cannot specify the page fixing option for each DD statement independently. But, the NOFIX control statement can be specified in the HSSROPT data set to prevent page-fixing.)

## BUFSTAT control statement

Specifies whether the extensive CAB Statistics report is produced in the HPPLIST data set or not.

For details of statistics, see [Chapter 28, "IPR Unload reports,"](#) on page 409.

This control statement is optional. The default is BUFSTAT=NO.

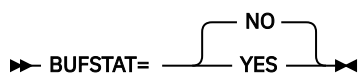

### YES

Produces the CAB Statistics report.

### NO

Does not produce the CAB Statistics report.

## BYINDEX control statement

Specifies whether to direct HSSR Call Handler to retrieve HIDAM or PHIDAM root segments sequentially through the HIDAM or PHIDAM primary index instead of through the root-twin chain.

If the root segments have no twin backward or hierarchical backward pointer, the BYINDEX statement has no effect.

You can also use a secondary index for HIDAM or HDAM root segments.

This control statement is optional. The default is BYINDEX=NO.

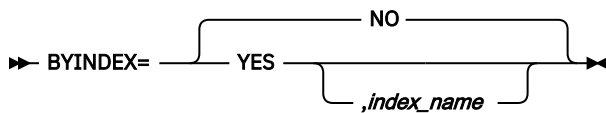

**NO**

Specifies to retrieve root segments through the root-twin chain.

**YES**

Specifies to retrieve root segments through the primary index or secondary index.

**index\_name**

Specifies a secondary index of the HIDAM or HDAM database if you want the root segments to be retrieved in the secondary index sequence. The target segment of the index must be the root segment.

**Notes:**

- If APISET=3 is specified, this statement cannot be specified.
- If one or more partitions of PHDAM or PHIDAM are in the HALDB OLR cursor-active status, BYINDEX=YES is ignored.

**CABBASE control statement**

This optional control statement specifies, in number of tracks, the basic size of I/O buffers that the CAB buffer handler allocates.

The *seq\_buf\_amount* and *dir\_buf\_num* values on the BUFFERS control statement are determined from the CABBASE control statement value and the CI/block size of the database data set. If the *seq\_buf\_amount* or *dir\_buf\_num* is specified on the BUFFERS control statement, the *seq\_buf\_amount* value or the *dir\_buf\_num* value has precedence over the CABBASE control statement value.

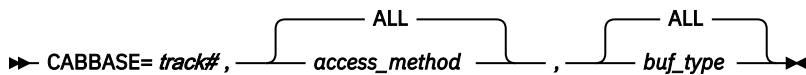

**track#**

Specifies the number of tracks.

The acceptable value is in the range of 1 - 255. For VSAM sequential buffering, the value must be in the range of 1 - 15.

**access\_method**

Specifies the access method of the data set to which this statement is applied.

**ALL**

Indicates that this statement applies to all ESDS, OSAM LDS, or OSAM data sets.

**VSAM**

Indicates that this statement applies to all ESDS or OSAM LDS data sets.

**OSAM**

Indicates that this statement applies to all OSAM data sets.

**buf\_type**

Specifies the buffering type to which this statement is applied.

**ALL**

Indicates that this statement applies to both sequential buffering and direct buffering.

**SEQ**

Indicates that this statement applies to sequential buffering.

**DIR**

Indicates that this statement applies to direct buffering.

The default value is determined based on the access method as follows:

- For OSAM sequential buffering: 1 track (CABBASE=1,OSAM,SEQ)
- For OSAM direct buffering: 2 tracks (CABBASE=2,OSAM,DIR)
- For VSAM sequential buffering: 8 tracks (CABBASE=8,VSAM,SEQ)
- For VSAM direct buffering: 15 tracks (CABBASE=15,VSAM,DIR)

If the VSAM CI size is smaller than 2 KB, the CAB buffer handler applies the following values:

- For sequential buffering: 4 tracks (CABBASE=4,VSAM,SEQ)
- For direct buffering: 8 tracks (CABBASE=8,VSAM,DIR)

**Tips:**

- The following statement is recommended to improve the performance of CAB sequential I/O buffering for OSAM data sets: CABBASE=8, OSAM, SEQ

This statement changes the basic size of OSAM sequential buffers from one track to eight tracks.

- You can change the default value of this control statement by creating an Installation Default Option Table (HPSCOPI). For more information, see [Chapter 45, “Setting installation default options,”](#) on page 617.

## COMPAREDLI control statement

Specifies whether to compare with the DL/I call result or not.

The COMPAREDLI statement is intended to be used for problem determination of HSSR calls. If COMPAREDLI=YES is specified, each call for the HSSR PCB is made first by DL/I, and the same call is then made by HSSR Engine; then, the resultant I/O areas and PCBs of both calls are compared. If a mismatch is found, the I/O areas and the PCBs are printed on the HPSTRACE data set and the IPR Unload utility produces a dump and ends abnormally.

This control statement is optional. The default is COMPAREDLI=NO.

**Usage note:** This control statement is not available for the Unload task of the Smart Reorg utility. If the control statement is specified, it is ignored.

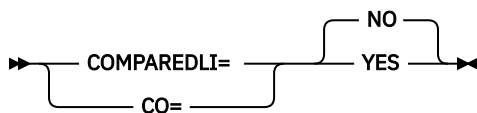

The abbreviation CO= can be used for COMPAREDLI=.

**NO**

Does not activate the compare option.

**YES**

Activates the compare option. If a mismatch is found, the IPR Unload utility ends abnormally.

**Notes:**

- If COMPAREDLI=YES is specified, the database data sets must be allocated with DISP=SHR.
- If APISET=3 is specified, the comparison is not done for the calls that are finally processed by DL/I.
- If one or more partitions of PHDAM or PHIDAM are in the HALDB OLR cursor-active status, COMPAREDLI=YES is ignored.

## COMPAUTH control statement

Specifies whether to call the segment compression exit in supervisor state. This control statement is applicable only when you specify DECOMPRESS=YES.

If you use an encryption exit of InfoSphere® Guardium® Data Encryption for Db2® and IMS Databases as the segment compression exit, specifying COMPAUTH=YES reduces performance degradation.

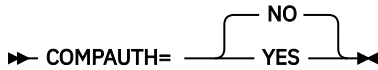

### YES

The segment compression exit is called in supervisor state. The following conditions must be met:

- All of the STEPLIB libraries are APF-authorized.
- The first load module is link-edited with authorization code AC=1 . This is the same as how the HPSCMAIN or HPSGMAIN program is link-edited.

### NO

The segment compression exit is called in problem state. NO is the default.

**Tip:** You can change the default value of this control statement by creating an Installation Default Option Table (HPSCOPTI). For more information, see [Chapter 45, “Setting installation default options,” on page 617.](#)

## DATXEXIT control statement

Specifies whether the Data Conversion exit routine (DFSDBUX1) is activated for each database call.

**Note:** The support for the DFSDBUX1 exit is restricted to the exit routine provided by the Y2K Exit Tool. No other Data Conversion exit routine is supported.

This control statement is optional. The default is DATEXEXIT=NO.

**Usage note:** This control statement is not available for the Unload task of the Smart Reorg utility. If the control statement is specified, it is ignored.

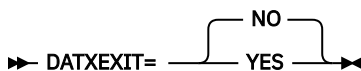

### NO

Requests that the IPR Unload utility does not call DFSDBUX1 even if it is in a library that is concatenated to STEPLIB. The option DATXEXIT=NO has the same effect as to remove module DFSDBUX1 from STEPLIB libraries.

### YES

Requests that the IPR Unload utility treats DFSDBUX1 in the same way that IMS does through IMS's Data Conversion exit routine. If DATXEXIT=YES is specified, the module DFSDBUX1 exists in a STEPLIB library, and the use of the Data Conversion exit routine is designated for the database, then DFSDBUX1 is called each time a DL/I call or an HSSR call is issued against the database.

## DBSTATS control statement

Specifies whether to activate the database statistics function.

This control statement is optional. The default is DBSTATS=NO.

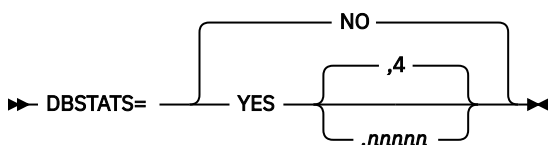



## KEYCHECK control statement

Specifies whether to check the sequence of sequenced keys or not.

The KEYCHECK control statement is used when you want to make sure that the segment key fields are in the ascending order.

This control statement is optional. The default is KEYCHECK=NO.

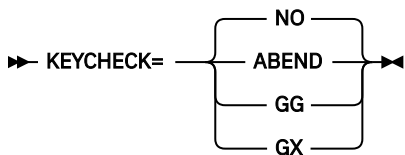

### NO

Does not perform key checking. The abbreviation N can be used for NO.

### ABEND

Performs key checking and abnormally ends when a sequence error is detected.

### GG

Performs key checking and returns a GG status code if a sequence error is detected. No segment will be returned to the IPR Unload utility.

This option requires an active SKIPERROR control statement; if none of the conditions is specified, HSSR Engine abends instead of returning a GG status code. If the SKIPERROR statement is active, HSSR Engine does not retrieve the incorrect segment or other related segments during the processing of the next GN call. If the SKIPERROR control statement is inactive, HSSR Engine resets the current position to the beginning of the database.

### GX

Performs key checking and returns a warning GX status code if a sequence error is detected. The segment with the incorrect key is returned to the IPR Unload utility.

For the EXEC DLI command, the status GX is not returned to the application program. Instead, message DFS1041 is issued in the EXEC DLI interface module (DFSEIPB0). The module ends with a code of U1041.

### Notes:

- If APISET=3 is specified, this statement cannot be specified.
- If one or more partitions of PHDAM or PHIDAM are in the HALDB OLR cursor-active status, KEYCHECK=ABEND/GG/GX is ignored.

## LOUT control statement

The LOUT control statement specifies whether to produce the optional output record containing the following data in the HPSLOUT data set.

- Length of the database record (fullword)
- The number of database I/Os required to read all database segments of the database record (fullword)
- Key of the database root segment

This control statement is optional. The default is LOUT=NO.

**Usage note:** This control statement is not available for the Unload task of the Smart Reorg utility. If the control statement is specified, it is ignored.



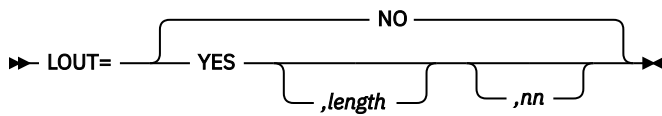

**NO**

The record is not produced.

**YES**

The record is produced. The HPSLOUT DD statement is required.

**length**

Requests that the HPSLOUT data set contains only the records for database records whose length is greater than the specified value.

**nn**

Requests that the HPSLOUT data set contains only the records for database records whose database I/O count for their retrieval is greater than the specified value.

## PARTINFO control statement

Specifies whether any optional a HALDB information is to be reported when a HALDB is processed.

This control statement is optional. The default is PARTINFO=YES.

**Usage note:** This control statement is not available for the Unload task of the Smart Reorg utility. If the control statement is specified, it is ignored.

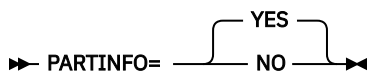

**YES**

Initiates HSSR Engine to produce the HALDB Partition Definition report.

**NO**

Initiates HSSR Engine not to produce the above report.

Information specified on this statement affects the number of lines written in the HPSOUT data set. For details, see [Chapter 28, "IPR Unload reports,"](#) on page 409.

**Tip:** You can change the default value of this control statement by creating an Installation Default Option Table (HPSCOPTI). For more information, see [Chapter 45, "Setting installation default options,"](#) on page 617.

## PARTSTAT control statement

Specifies whether to generate the partition-wide report for the Segment Count Summary report and the DB Call Statistics report. This specification is valid only for a HALDB.

This control statement is optional. The default is PARTSTAT=YES.

**Note:** For the IPR Unload utility task of the Smart Reorg utility, PARTSTAT=NO is used as the default.

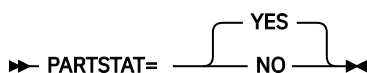

**YES**

Generates the partition-wide reports.

## NO

Does not generate the partition-wide reports.

## RTEXTIT control statement

Specifies the runtime environment exit routine that can do the initialization and the termination processing required by the user's environment, such as a COBOL II runtime environment.

The HPSURTEX module is provided as a default runtime environment exit routine, which is a dummy exit routine and returns to the IPR Unload utility without any processing.

This control statement is optional. The default is RTEXTIT=HPSURTEX.

➔ RTEXTIT=  ➔

If any initialization or termination processing is required due to your environment, you can modify this routine or write your own exit routine.

The runtime environment exit routine is called before and after the IPR Unload utility is invoked. If no RTEXTIT control statement is specified, the IBM-supplied HPSURTEX module or the user-written HPSURTEX module is called as the runtime environment exit routine.

The interface of runtime environment exit is exactly the same as the runtime environment exit for IMS HP Unload except for the names of the default exit routine. For more information, see the topic "Runtime Environment exit (FABHRTEX)" in the *IMS High Performance Unload User's Guide*.

**Note:** IBM Enterprise COBOL Version 5 and later do not support the IGZERRE interface for the runtime environment setup. If the interface is used in your runtime environment exit routine, remove the RTEXTIT control statement. Instead, specify a language environment option to invoke CEEPIPI provided by Language Environment not only for initialization and termination calls but also for each segment call of your user exit routine for unload utilities. For more information, see ["OUTPUT control statement" on page 375](#).

### **exitname**

Specifies the left-aligned load module name of the runtime environment exit routine.

IMS HP Unload provides a sample COBOL II runtime environment exit routine named HPSUCOB2 in the SHPSLMD0 library. To invoke this exit routine, specify:

```
RTEXTIT=HPSUCOB2
```

## SKIPERROR control statement

Specifies the number of database errors to be bypassed.

This control statement is optional. The default is SKIPERROR=0.

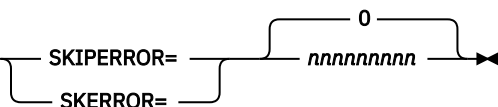
➔  ➔

This option allows unloading from a database, even if the database contains incorrect HD pointers or incorrect HISAM records. This is achieved by skipping the processing of the incorrect pointer or of the remainder of the incorrect HISAM record. A GG status code is returned.

If SKIPERROR is active, the IPR Unload utility cannot process segments with segment codes in error.

SKIPERROR is used when a damaged HIDAM, HDAM, PHIDAM, PHDAM, or HISAM database is unloaded. For the general guideline for unloading damaged databases, see [Chapter 31, "Tips for unloading damaged databases," on page 481](#).

If the SKERROR statement is specified for a HALDB and the IPR Unload utility encounters an unavailable partition, the processing of the partition is skipped.

For details, see [Chapter 28, “IPR Unload reports,”](#) on page 409.

The abbreviation SKERROR= can be used for SKIPERROR=.

#### **nnnnnnnnn**

Specifies the maximum number of incorrect records to be skipped. Enter any number up to 9 digits, left-aligned, and followed by a blank. If more than the specified number of GG status codes are returned, HSSR Engine ends abnormally.

#### **Considerations:**

- If APISET=3 is specified, this statement cannot be specified.
- If one or more partitions of PHDAM or PHIDAM are in the HALDB OLR cursor-active status, SKIPERROR=nnnnnnnnn is ignored.

## **TRACE control statement**

Specifies HSSR Engine's tracing facility options.

This control statement is optional. If you do not specify this control statement, the trace information is not generated at all.

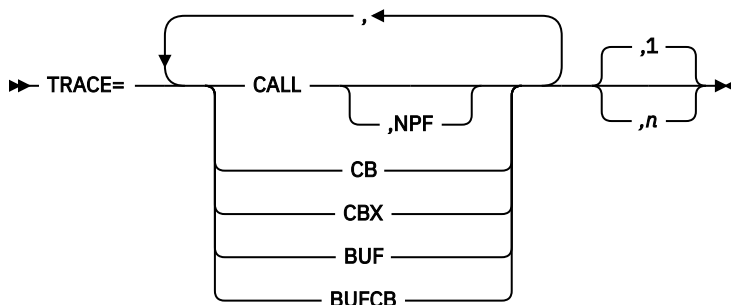

The objects of trace are specified by keywords. The last numeric operand *n* specifies the sequence number of HSSR call from which the trace facility is activated. You can specify any number up to nine digits. The default is 1.

#### **CALL**

Traces such call information as the call function, PCB, IOAREA, SSA, and segment prefix. You can optionally specify NPF keyword after the keyword CALL to exclude the segment prefix information from the call trace.

The EXEC DLI command can be traced just the same as the DL/I call. This is because the HSSR call handler converts the format of the EXEC DLI command into one like that of the DL/I call.

#### **NPF**

Excludes the segment prefix information from the call trace. This keyword, if specified, must be specified just after the keyword CALL.

#### **CB or CBX**

Traces control blocks of HSSR Engine. If CBX is specified, traces are also done for the extended control blocks of HSSR Engine. If both CB and CBX are specified, CBX is taken.

#### **BUF**

Traces I/O buffers.

#### **BUFCB**

Traces buffer handler control blocks.

#### **Notes:**

- All operands are optional, but you must specify at least one operand.

- The trace of the control blocks of HSSR Engine (which is called for by specifying the CB, CBX, BUF, or BUFCB option for the TRACE control statement) is not intended to be reviewed by users, but might be needed by the IBM Support Center to analyze a problem.
- If TRACE=CALL is specified and a HALDB is processed in the Smart Reorg utility, data in the I/O area is not printed in the Trace Output report.

## ZIIPMODE control statement

Specifies whether HSSR engine offloads eligible VSAM ESDS I/O or OSAM LDS I/O workloads to zIIP processors.

This control statement is optional. The default is ZIIPMODE=NEVER.

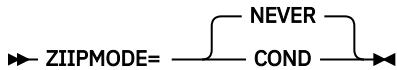

### COND

Offloads VSAM ESDS I/O or OSAM LDS I/O workloads to zIIP processors when all of the following conditions are met:

- zIIP processor are available.
- The SGLXLOAD library of IMS Tools Base is specified to the STEPLIB or JOBLIB.
- VSAM ESDS is to be read using Media Manager. Media Manager is available only when the STEPLIB libraries are all APF-authorized. For more information, see [“DD statements” on page 360](#).

If any of these conditions is not satisfied, the job runs using the main CPs.

### NEVER

Does not offload any workload to zIIP processors. NEVER is the default to avoid unexpected performance degradation.

**Tip:** You can change the default value of this control statement by creating an Installation Default Option Table (HPSCOPTI). For more information, see [Chapter 45, “Setting installation default options,” on page 617](#).

---

## Chapter 27. IPR Unload JCL examples

The following topics present the effective uses of the IPR Unload utility.

### Topics:

- [“Example 1: Unloading an IMS database” on page 405](#)
- [“Example 2: Unloading a partition of a HALDB” on page 405](#)
- [“Example 3: Unloading a damaged database” on page 406](#)
- [“Example 4: Unloading using JCL for IMS HD Reorganization Unload” on page 406](#)
- [“Example 5: Unloading a database in an IMS-managed ACBs environment” on page 407](#)
- [“Example 6: Unloading a database with the IMS Catalog Definition exit routine” on page 407](#)

---

### Example 1: Unloading an IMS database

This JCL example is for unloading an IMS database to create an unloaded data set that can be used as input to the IPR Reload utility.

To create an unloaded data set that can be used as input to the IPR Reload utility, you can use the JCL stream shown in the following figure. The unloaded data set is defined by the SYSUT2 DD statement; the database that is unloaded is defined by the DBSAMP01 DD statement. The HD format is used by default in this example.

If the input database is a HALDB, DBRC=Y must be specified in the EXEC parameter and the RECON data sets must be allocated dynamically or by coding the RECONx DD statements in the JCL stream. If you unload a HALDB, you do not need to code the DD statements for the database data sets because they are dynamically allocated.

The following figure shows an example of a JCL stream to unload an IMS database.

```
//UNLOAD EXEC PGM=HPSCMAIN, PARM=' FUNC=UL, DBD=DBSAMP01 '  
//STEPLIB DD DSN=HPS.SHPSLMD0, DISP=SHR  
// DD DSN=IMS.RESLIB, DISP=SHR  
//DFSRESLB DD DSN=IMS.RESLIB, DISP=SHR  
//IMS DD DSN=IMS.DBDLIB, DISP=SHR  
//HPSOUT DD SYSOUT=A  
//HPSSNAP DD SYSOUT=A  
//SYSUDUMP DD SYSOUT=A  
//DBSAMP01 DD DSN=DBSAMP01.DATA1, DISP=OLD  
//SYSUT2 DD DSN=DBSAMP01.UNLOAD, DISP=(NEW,PASS),  
// SPACE=(CYL,(20,10))
```

Figure 137. Sample JCL stream to unload an IMS database

---

### Example 2: Unloading a partition of a HALDB

This JCL example is for unloading a partition of HALDB to create an unloaded data set that can be used as input to the IPR Reload utility.

To unload a partition of a HALDB to create an unloaded data set that can be used as input to the IPR Reload utility, you can use the JCL stream shown in the following figure.

```

//UNLOAD EXEC PGM=HPSCMAIN, PARM= ' FUNC=UL , DBD=PHDAMDB1 , DBRC=Y '
//STEPLIB DD DSN=HPS.SHPSLMD0, DISP=SHR
// DD DSN=IMS.RESLIB, DISP=SHR
//DFSRESLB DD DSN=IMS.RESLIB, DISP=SHR
//IMS DD DSN=IMS.DBDLIB, DISP=SHR
//HPSOUT DD SYSOUT=A
//HPSLIST DD SYSOUT=A
//HPSSNAP DD SYSOUT=A
//SYSUDUMP DD SYSOUT=A
//SYSUT2 DD DSN=PART1.UNLOAD, DISP=(NEW, PASS) ,
// SPACE=(CYL, (20,10))
//HPSIN DD *
PARTITION=PART1
/*

```

Figure 138. Sample JCL stream to unload a partition of a HALDB

DBRC=Y must be specified in the EXEC parameter and the RECON data sets must be allocated dynamically or by coding the RECONx DD statements in the JCL stream. In the example, it is assumed that the RECON data sets are dynamically allocated. When you unload a HALDB, you do not need to code the DD statements for the database data sets, because they are dynamically allocated.

In the JCL stream, PARTITION control statement is coded to specify which partition (PART1) to unload. The HALDB Partitions Processed report and the HALDB Partition Definition report are written in HPSOUT.

### Example 3: Unloading a damaged database

This JCL example is for unloading a damaged database.

To unload a damaged database, you can use the JCL stream shown in the following figure. The unloaded data set is defined by the SYSUT2 DD statement; the database that is unloaded is defined by the DBSAMP01 DD statement. HPSIN options SKIPERROR=9999, KEYCHECK=GG, and DIAGG=YES are specified. OUTLIM is specified on the HPSTRACE DD statement.

```

//UNLOAD EXEC PGM=HPSCMAIN, PARM= ' FUNC=UL , DBD=DBSAMP01 '
//STEPLIB DD DSN=HPS.SHPSLMD0, DISP=SHR
// DD DSN=IMS.RESLIB, DISP=SHR
//DFSRESLB DD DSN=IMS.RESLIB, DISP=SHR
//IMS DD DSN=IMS.DBDLIB, DISP=SHR
//HPSOUT DD SYSOUT=A
//HPSSNAP DD SYSOUT=A
//SYSUDUMP DD SYSOUT=A
// *
//DBSAMP01 DD DSN=DBSAMP01.DATA1, DISP=OLD
//SYSUT2 DD DSN=DBSAMP01.UNLOAD, DISP=(NEW, PASS) ,
// SPACE=(CYL, (20,10))
//HPSTRACE DD SYSOUT=A, OUTLIM=100000000
//HPSIN DD *
SKIPERROR=9999
KEYCHECK=GG
DIAGG=YES
/*

```

Figure 139. Sample JCL stream to unload a damaged database

For the general guideline of unloading damaged databases, see [Chapter 31, “Tips for unloading damaged databases,”](#) on page 481.

**Note:** The compressed segments are not decompressed by default. If you need to decompress these segments, you must specify DECOMPRESS=YES in the HPSIN data set.

### Example 4: Unloading using JCL for IMS HD Reorganization Unload

This JCL example is for unloading a database using IMS HD Reorganization Unload JCL.

You can use JCL that is written for IMS HD Reorganization Unload (DFSURGU0) to run the IPR Unload utility. The following figure shows an example of JCL stream. For more information, see [“Using JCL for IMS HD Reorganization Unload”](#) on page 364.

```

//UNLOAD EXEC PGM=DFSRR00,PARM='ULU,DFSURGU0,DBSAMP04'
//STEPLIB DD DSN=IPR.SHPSLMD0,DISP=SHR IPR library
// DD DSN=HPU.SHPSLMD0,DISP=SHR HP Unload library
// DD DSN=IMS.SDFSRESL,DISP=SHR
// DD DSN=USER.MDALIB,DISP=SHR
// DD DSN=USER.PGMLIB,DISP=SHR
//SYSPRINT DD SYSOUT=A
//SYSUDUMP DD SYSOUT=A
//DFSRESLB DD DSN=IMS.SDFSRESL,DISP=SHR
//IMS DD DSN=IMS.DBDLIB,DISP=SHR
//DFSURGU1 DD DSN=DBSAMP04.UNLOAD,DISP=(NEW,PASS)
// SPACE=(CYL,(20,10))
//HPSIN DD *
DECOMPRESS=YES
OUTPUT=,,(MYEXIT1,B)
/*

```

Figure 140. Sample IMS HD Reorganization Unload JCL used for the IPR Unload utility

In this example, the OUTPUT control statement is coded in the HPSIN DD data set to use a Type-B user exit routine. Because the user exit refers to the segment data, the DECOMPRESS=YES control statement is also coded to expand the compressed segment data. If DECOMPRESS=YES is already specified in the Installation Default Option Table (HPSCOPTI), the option is not needed here. If any optional functions are not used, the HPSIN DD statement is not needed.

## Example 5: Unloading a database in an IMS-managed ACBs environment

This JCL example is for unloading a database in an IMS-managed ACBs environment.

If the IMS management of ACBs is enabled, you can unload a database without the IMS DD statement.

```

//UNLOAD EXEC PGM=HPSCMAIN,PARM='FUNC=UL,DBD=DBSAMP01,DBRC=Y,DFSDF=CAT'
//STEPLIB DD DSN=HPS.SHPSLMD0,DISP=SHR
// DD DSN=IMS.SDFSRESL,DISP=SHR
// DD DSN=ITB160.SGLXLOAD,DISP=SHR
//DFSRESLB DD DSN=IMS.SDFSRESL,DISP=SHR
//PROCLIB DD DSN=IMS.PROCLIB,DISP=SHR
//HPSOUT DD SYSOUT=A
//HPSSNAP DD SYSOUT=A
//SYSUDUMP DD SYSOUT=A
//DBSAMP01 DD DSN=DBSAMP01.DATA1,DISP=OLD
//SYSUT2 DD DSN=DBSAMP01.UNLOAD,DISP=(NEW,PASS),
// SPACE=(CYL,(20,10))

```

Figure 141. Sample JCL stream to unload a database in an IMS-managed ACBs environment

DFSDF=CAT parameter is specified on the EXEC statement. This parameter specifies the DFSDFCAT member that enables IMS-managed ACBs.

The name of the IMS.PROCLIB data set in which the DFSDFCAT member exists is specified on the PROCLIB DD statement.

The name of the SGLXLOAD library of IMS Tools Base is specified on the STEPLIB DD statement.

You must allocate the catalog partition definition data set when unloading a database with DBRC=NO. To do so, add the DFSHDBSC DD statement or the DFSMDA member with the TYPE=CATDBDEF statement.

## Example 6: Unloading a database with the IMS Catalog Definition exit routine

This JCL example is for unloading a database in an IMS-managed ACBs environment with the IMS Catalog Definition exit routine (DFS3CDX0).

When the IMS management of ACBs is enabled, you can unload a database without the IMS DD statement.

```

//UNLOAD EXEC PGM=HPSCMAIN, PARM=' FUNC=UL, DBD=DBSAMP01, DBRC=Y'
//STEPLIB DD DSN=HPS.SHPSLMD0, DISP=SHR
// DD DSN=IMS.SDFSRESL, DISP=SHR
// DD DSN=ITB160.SGLXLOAD, DISP=SHR
//DFSRESLB DD DSN=IMS.SDFSRESL, DISP=SHR
//HPSOUT DD SYSOUT=A
//HPSSNAP DD SYSOUT=A
//SYSUDUMP DD SYSOUT=A
//DBSAMP01 DD DSN=DBSAMP01.DATA1, DISP=OLD
//SYSUT2 DD DSN=DBSAMP01.UNLOAD, DISP=(NEW, PASS),
// SPACE=(CYL, (20, 10))

```

*Figure 142. Sample JCL stream to unload a database with the DFS3CDX0 exit routine*

The DFS3CDX0 exit routine must be bound to IMS.SDFSRESL or a concatenated library.

The name of the SGLXLOAD library of IMS Tools Base is specified on the STEPLIB DD statement.

You must allocate the catalog partition definition data set when unloading a database with DBRC=NO. To do so, add the DFSHDBSC DD statement or the DFSMDA member with the TYPE=CATDBDEF statement.



---

## Chapter 28. IPR Unload reports

The IPR Unload utility produces the reports and statistics in the HPSOUT data set, the HPSSLIST data set, and the HPSRAPC data set.

### Topics:

- [“Report reference table for IPR Unload” on page 409](#)
- [“Environment report” on page 412](#)
- [“Default Option Tables report” on page 414](#)
- [“HPSIN Control Statements report” on page 414](#)
- [“Decoded DBD report” on page 416](#)
- [“DBD Summary report” on page 416](#)
- [“HALDB Partitions Processed report” on page 421](#)
- [“Segment Count Summary report” on page 421](#)
- [“Segment Statistics report” on page 428](#)
- [“HDAM Root Addressable Area Statistics report” on page 435](#)
- [“HDAM RAP Chain I/O Summary report” on page 439](#)
- [“Distribution of Database Record Sizes report” on page 442](#)
- [“Largest Database Records report” on page 443](#)
- [“HISAM Statistics report” on page 443](#)
- [“Data Set Statistics report” on page 444](#)
- [“Buffering and I/O Statistics report” on page 447](#)
- [“HALDB Partition Definition report” on page 451](#)
- [“HDAM RAPCHECK Incorrect RAP Chain report” on page 452](#)

---

### Report reference table for IPR Unload

The IPR Unload utility produces the reports and statistics in the HPSOUT, HPSSLIST, and HPSRAPC data sets.

#### Subsections:

- [“Reports in the HPSOUT data set” on page 409](#)
- [“Reports in the HPSSLIST data set” on page 411](#)
- [“Report in the HPSRAPC data set” on page 411](#)
- [“Reports for problem determination” on page 411](#)
- [“IPR Unload reports in IMS Tools Knowledge Base” on page 412](#)

#### Reports in the HPSOUT data set

The following table summarizes the reports that are written in the HPSOUT data set by the IPR Unload utility.

Table 54. IPR Unload utility reports in the HPSOUT data set

Report name	Description
Buffering and I/O Statistics report	This report is generated, for each data set group, for databases other than SHISAM. For HISAM databases, this report is generated only when an overflow data set is specified. This report contains the actual buffering parameter values that are used in the run and the statistics on I/O and buffer handler activities.
Data Set Statistics report	This report is generated for all database organizations. This report contains definition information and statistics information about database data sets. (see <a href="#">note</a> )
DB Statistics report	This report is generated for HDAM, HIDAM, PHDAM, PHIDAM, and HISAM databases (DBSTATS=YES must be specified.) For a HISAM database, this report is generated only when an overflow data set is specified. This report contains definition information and statistics information about the database.  The contents of the DB Statistics report are the same as those produced for IMS HP Unload. For details of the DB Statistics report, see the <i>IMS High Performance Unload User's Guide</i> and read the topic that explains how to tune a database by using the DB tuning statistics.
DBD Summary report	This report is generated for all database organizations. This report contains information defined in the DBD.
Decoded DBD report	This report is generated for all database organizations (DECODEDBD=YES must be specified.) This report contains the resulting DBD source statements for the decoded DBD.
Default Option Tables report	This report is generated for all database organizations. This report contains the contents of the System Default Option Table (HPSCOPTS) and the Installation Default Option Table (HPSCOPTI).
Distribution of Database Record Sizes report	This report is generated for databases other than SHISAM (other than DBRECDIST=0 must be specified.) This report contains the distribution of the lengths of database records. (see <a href="#">note</a> )
Environment report	This report is generated for all database organizations. This report contains the EXEC parameters that are specified for the job and the system environment information.
HALDB Partition Definition report	This report is generated for HALDBs (PARTINFO=YES must be specified.) This report contains the definition information about a HALDB.
HALDB Partitions Processed report	This report is generated for HALDBs. This report contains information about processed partitions.
HDAM RAP Chain I/O Summary report	This report is generated for HDAM and PHDAM databases (DBSTATS=YES must be specified.) This report contains information about the effectiveness of the randomizer modules of HDAM and PHDAM databases from the viewpoint of database I/O. (see <a href="#">note</a> )
HDAM Root Addressable Area Statistics report	This report is generated for HDAM and PHDAM databases. This report contains information about root segments and root anchor points in the database. (see <a href="#">note</a> )
HISAM Statistics report	This report is generated for HISAM databases. This report contains the number of logical records in a HISAM database or the chaining information of segments to the overflow data set.
HPSIN Control Statements report	This report is generated for all database organizations. This report contains an echo back of the control statements you specified in the HPSIN data set.
Largest Database Records report	This report is generated for all database organizations. This report contains the largest database records in the database or in each HALDB partition. (see <a href="#">note</a> )

Table 54. IPR Unload utility reports in the HPSOUT data set (continued)

Report name	Description
Segment Count Summary report	This report is generated for all database organizations. This report contains the input segment occurrences and the output segment occurrences of each segment type.
Segment Statistics report	This report is generated for all database organizations. This report contains information about segments in databases by segment type. (see <a href="#">note</a> )

**Note:** For HALDBs, the report is generated for each partition that is processed. When the high key selection is used, the report is generated in the order of the high key, and when the partition selection exit is used, it is generated in the order of the partition name.

## Reports in the HPSLIST data set

The HPSLIST data set contains the reports and statistics produced by HSSR Engine. The following table summarizes the reports that are written in the data set.

Table 55. IPR Unload utility reports in the HPSLIST data set

Report name	Description
DB Call Statistics report	This report contains statistics on the number of HSSR calls.
CAB Statistics report	This report contains details CAB information for the data set referred to by each PCB. <b>Note:</b> CAB (Chained Anticipatory Buffering) is the name of the buffering method provided by the buffer handler of HSSR Engine.

The reports and statistics produced in the HPSLIST data set are intended to be used for tuning HSSR Engine or for problem determination. These reports are the same as those written in the HSSRSTAT data set of IMS HP Unload. For details of the reports, see the *IMS High Performance Unload User's Guide* and read the topic that explains about reports and output from HSSR Engine.

## Report in the HPSRAPC data set

If RAPCHECK=YES is specified and one or more incorrect RAPs are detected in the RAP check, the HPSRAPC data set contains the HDAM RAPCHECK Incorrect RAP Chain report.

## Reports for problem determination

The following table summarizes the data sets that are provided for problem determination.

Table 56. IPR Unload utility reports for problem determination

Output data set	Report name	Description
HPSTRACE	HSSR Trace Output report	This report contains the trace information for GG status codes.
	HSSR Trace Output report with diagnostics	This report contains the trace information and diagnostics information for GG status codes.
HPSSNAP	Snapshot of the HSSR Engine control blocks	If any abnormality is detected during the initialization of HSSR Engine, this report contains the snapshot of the HSSR Engine control blocks. This data might be needed by IBM to analyze a problem.

The trace reports are the same as those written in the HSSRTRAC data set of IMS HP Unload, and the content of the HPSSNAP data set is the same as that of the HSSRSNAP data set of IMS HP Unload. For details, see the *IMS High Performance Unload User's Guide* and read the topic that explains about reports and output from HSSR Engine.

For other output data sets, see [Chapter 25, “IPR Unload JCL requirements,”](#) on page 359.

### IPR Unload reports in IMS Tools Knowledge Base

When the IPR Unload reports are stored in the Output repository of IMS Tools KB, the report names that are defined in IMS Tools KB are used for managing the reports. The following table lists the report names that are used in IMS Tools KB.

*Table 57. IPR Unload report names used in IMS Tools KB*

Report name	Long title	Short title
Data Set Statistics report	IPRUL-DATA SET STATISTICS	UL-DATA SET STATISTICS
DBD Summary report	IPRUL-DBD SUMMARY	UL-DBD SUMMARY
Distribution of Database Record Sizes report	IPRUL-DISTRIBUTION OF DATABASE RECORD SIZES	UL-DB RECORD SIZES DIST
Environment report	IPRUL-ENVIRONMENT	UL-ENVIRONMENT
HALDB Partition Definition report	IPRUL-HALDB DEFINITION	UL-HALDB DEFINITION
HALDB Partitions Processed report	IPRUL-HALDB PROCESSED	UL-HALDB PROCESSED
HDAM RAP Chain I/O Summary report	IPRUL-HDAM RAP CHAIN I/O SUMMARY	UL-HDAM RAP CHAIN I/O
HDAM Root Addressable Area Statistics report	IPRUL-HDAM ROOT ADDRESSABLE AREA STATISTICS	UL-HDAM RAA STATISTICS
HISAM Statistics report	IPRUL-HISAM STATISTICS	UL-HISAM STATISTICS
HPSIN Control Statements report	IPRUL-HPSIN CONTROL STATEMENTS	UL-HPSIN CONTROL STMT
Largest Database Records report	IPRUL-LARGEST DATABASE RECORDS	UL-LARGEST DB RECORDS
Segment Count Summary report	IPRUL-SEGMENT COUNT SUMMARY	UL-SEGMENT COUNT
Segment Statistics report	IPRUL-SEGMENT STATISTICS	UL-SEGMENT STATISTICS

## Environment report

The EXEC parameters specified for the job and the system environment information are printed in this report.

The following figure shows an example of the Environment report.

"ENVIRONMENT"

EXEC PARAMETERS

```

DATABASE TO REORGANIZE..... DBHD0030
GLOBAL SERVICE GROUP NAME..... IMSGSG1
ACTIVATE DBRC..... YES
ACTIVATE IRLM FOR NATIVE DL/I CALLS... YES
IRLM SUBSYSTEM NAME..... IRLM
MAKE ADDRESS SPACE SWAPPABLE..... YES
    
```

SYSTEM ENVIRONMENT

```

OPERATING SYSTEM..... z/OS 02.04.00
STORAGE MANAGEMENT..... DFSMS/zOS 02.04.00
IMS..... IMS 15.1.0
PRODUCT VERSION..... IMS DB REORG EXPERT V4.1.0
PROCESSOR TYPE..... 3906
NUMBER OF PROCESSOR(S)..... 2
    
```

Figure 143. Environment report for the IPR Unload utility

The meaning of the fields in the Environment report is as follows:

**EXEC PARAMETERS**

Information about each keyword specified in the EXEC statement.

**DATABASE TO REORGANIZE**

The DBD name of the database specified as the DBD= parameter in the EXEC statement.

**GLOBAL SERVICE GROUP NAME**

The name of global service group (GSG) to be used for the RSR complex specified as the GSGNAME= parameter in the EXEC statement. If the GSGNAME= parameter is not specified, (SYSTEM DEFAULT) is displayed.

**ACTIVATE DBRC**

Status of use of DBRC specified as the DBRC= parameter in the EXEC statement.

- If DBRC=Y is specified, YES is displayed.
- If DBRC=N is specified, NO is displayed.
- If the DBRC= parameter is not specified, the default setting determined by IMS system generation is used.

**ACTIVATE IRLM FOR NATIVE DL/I CALLS**

Status of use of IRLM specified as the IRLM= parameter in the EXEC statement.

- If IRLM=Y is specified, YES is displayed.
- If IRLM=N is specified, NO is displayed.
- If the IRLM= parameter is not specified, (SYSTEM DEFAULT) is displayed.

**IRLM SUBSYSTEM NAME**

The IRLM subsystem name specified as the IRLMNM= parameter in the EXEC statement. This item is displayed only if IRLM=Y is specified.

- If IRLM=Y is specified and if the IRLMNM= parameter is not specified, (SYSTEM DEFAULT) is displayed.
- If IRLM=N is specified or if the IRLM= parameter is not specified, this item is not displayed, no lines altogether.

**MAKE ADDRESS SPACE SWAPPABLE**

Specifies whether to enable or disable the swapping of address space specified as the SWAP= parameter in the EXEC statement.

- If SWAP=Y is specified, YES is displayed.

- If SWAP=N is specified or if the SWAP= parameter is not specified, NO is displayed.

### SYSTEM ENVIRONMENT

Information about the system environment.

### OPERATING SYSTEM

The release level of the operating system.

### STORAGE MANAGEMENT

The release level of the storage management subsystem.

### IMS

The release level of IMS.

### PRODUCT VERSION

The release level of IMS Database Reorganization Expert.

### PROCESSOR TYPE

The type number of the central processor.

### NUMBER OF PROCESSOR(S)

The number of physical processors.

## Default Option Tables report

This report contains the contents of the System Default Option Table (HPSCOPTS) and the Installation Default Option Table (HPSCOPTI).

If HPSCOPTI was used, this report shows both HPSCOPTS and HPSCOPTI. If HPSCOPTS was used, this report shows only HPSCOPTS. For details of the Installation Default Option Table, see [Chapter 45, "Setting installation default options,"](#) on page 617.

The following figure is an example of the Default Option Tables report.

```

IMS HIGH PERFORMANCE UNLOAD                                PAGE:          1
5655-E06                                                    11/01/2023  17.24.31

                "DEFAULT OPTION TABLES"

        SYSTEM DEFAULT: HPSCOPTS IN RGE410.SHPSLMD0
INSTALLATION DEFAULT: HPSCOPTI IN RGE410.SHPSLMD0

KEYWORD          SYSTEM DEFAULT          INSTALLATION DEFAULT
-----          -
APISET           1                       1
BLDLPCK         NO                       NO
CABBASE_OS      1                       8
CABBASE_OD      2                       15
CABBASE_VS      8                       8
CABBASE_VD     15                       15
CHECKREC        NO                       NO
COMPAUTH        NO                       NO
DECODEDBD       NO                       YES
DECOMPRESS      NO                       NO
ITKBLOAD        *NO                      *NO
ITKBSRVR        *NO                      *NO
JCLTYPE         N/A                      N/A
PARTINFO        YES                       YES
PCBLIST         HSSR                      HSSR
STATREP         YES                       YES
ZIIPMODE        NEVER                      COND

```

Figure 144. Default Option Tables report

## HPSIN Control Statements report

This report contains an echo back of the control statements you specified in the HPSIN data set. You can make sure the parameters used by the IPR Unload utility for this job step run with this report.

The following figure shows an example of the HPSIN Control Statements report.

"HPSIN CONTROL STATEMENTS"

0.....1.....2.....3.....4.....5.....6.....7.....8  
1234567890123456789012345678901234567890123456789012345678901234567890  
DBSTATS=YES  
DECODEDBD=YES

"RUN TIME OPTIONS FOR THIS EXECUTION"

DBD : IPRULHDV DBORG : HDAM

OPTIONS FOR UNLOAD FUNCTION:

KEYWORD	VALUE
CHECKREC	NO
DBRECDIST	(100,200,300,400,500,600,700,800,900,1000,2000,3000,4000,5000)
DBRECDIST	(6000,7000,8000,9000,10000)
DBRECKEYS	10
DECODEDBD	YES
DECOMPRESS	NO
FALLBACK	N/A (THIS OPTION IS IGNORED WHEN NON-HALDB)
HOMECHK	(-10,+10)
ITKBSRVR	*NO
ITKBLOAD	N/A
MIGRATE	NO
OUTPUT	SYSUT2,*HD
PARTITION	N/A (THIS IS NOT A PARTITIONED DATABASE.)
PROGMON	0
SEGSEL	*ALL
SKIPAUTH	NO
STATREP	YES
USERHDR	N/A (*UH IS NOT SPECIFIED ON OUTPUT CONTROL STATEMENT)

OPTIONS FOR HSSR ENGINE:

KEYWORD	VALUE
BLDLPCK	NO
BUFFERS	*ALL, ,8, ,100, YES, YES
BUFSTAT	NO
BYINDEX	NO
CABBASE	1, OSAM, SEQ
CABBASE	2, OSAM, DIR
CABBASE	8, VSAM, SEQ
CABBASE	15, VSAM, DIR
COMPAUTH	NO
DATXEXIT	NO
DBSTATS	YES, 4
KEYCHECK	NO
LOUT	NO
PARTINFO	NO
PARTSTAT	NO
RTEXTIT	HPSURTEX
SKIPERROR	0
ZIIPMODE	NEVER

OPTIONS FOR DIAGNOSIS:

KEYWORD	VALUE
COMPAREDLI	NO
DIAGG	NO
RAPCHECK	NO
TRACE	(NONE)

Figure 145. HPSIN Control Statements report for the IPR Unload utility

In the report, the control statements you specified in the HPSIN data set are listed under the scale. An error message or a warning message is printed under the echo back of the control statement that turned out to be incorrect. The "RUN TIME OPTIONS FOR THIS EXECUTION" part lists options to be used for this utility run.

**DBD**

DBD name of the database.

**DBORG**

Database organization: HDAM, HIDAM, HISAM, or SHISAM; partitioned or nonpartitioned database.

**OPTIONS FOR UNLOAD FUNCTION**

Options effective for unload function.

**OPTIONS FOR HSSR ENGINE**

Options effective for HSSR Engine.

**OPTIONS FOR DIAGNOSIS**

Options effective for diagnosis.

## Decoded DBD report

---

When the DECODEDBD control statement requests that a DBD be decoded, the resulting DBD source statements are printed in this report.

The following figure is an example of the Decoded DBD report.

```

IMS HIGH PERFORMANCE UNLOAD                                PAGE:      1
5655-E06                                                    10/05/2023 17.31.29

*****
*                                                                 *
*                               DBHD0210                        *
*                                                                 *
*                               DECODED BY IMS LMU REVERSAL    *
*****
*          DSNAME=TESTDS.OSFC7606.DBDLIB                      *
*          VOL=DBT005                                         *
*          DBDGEN DATE 09/05/2023 TIME 17.31                  *
*          DBD      NAME=DBHD0210,ACCESS=(HDAM,VSAM),          C
*                   RMNAME=(DFSHDC40,5,1000,200),PASSWD=NO,   C
*                   VERSION=          DATE 09/05/23 TIME 17.31
*****
*          DATASET GROUP NUMBER 1                             *
*****
*          DSG001 DATASET DD1=DDHD0210,SIZE=(2048),SCAN=3    *
*****
*          SEGMENT NUMBER 1                                   *
*****
*          SEGM      NAME=ROOTLEV1,PARENT=0,BYTES=20,RULES=(LLL,LAST), C
*                   PTR=(TWINBWD,,,,)
*          FIELD    NAME=(ROOTNO,SEQ,U),START=1,BYTES=8,TYPE=C
*          FIELD    NAME=(ROOTNAME),START=9,BYTES=12,TYPE=C
*          LCHILD   NAME=(ROOTKEY,DBSX0210),PTR=INDX,RULES=LAST
*          XDFLD    NAME=XROOTNO,SEGMENT=,SRCH=(ROOTNO)
*****
*          SEGMENT NUMBER 2                                   *
*****
*          SEGM      NAME=DEP1LEV2,PARENT=((ROOTLEV1,)),BYTES=21, C
*                   RULES=(LLL,LAST),PTR=(TWINBWD,,,,)
*          FIELD    NAME=(DEP1NO,SEQ,U),START=1,BYTES=8,TYPE=C
*          FIELD    NAME=(DEP1NAME),START=9,BYTES=13,TYPE=C
*          DBDGEN
*          FINISH
*          END

```

Figure 146. Decoded DBD report for the IPR Unload utility

## DBD Summary report

---

This report provides information defined in the DBD.

The following are examples of DBD Summary reports.

The following figure is an example of the DBD Summary report for an HDAM database.



"DBD SUMMARY"

DATABASE=DBHD0010 ORGANIZATION=HDAM ACCESS METHOD=ESDS DSGROUPS=1  
RANDOMIZER=DFSHDC20 NBR OF RAPS=1 MAX RBN=10 MAX BYTES=

SEGMENT	SC	LVL	DSG	PARENT	<-LENGTHS->		<-FLAGS->	<-----POINTER----->	
					PFX LEN	DATA LEN		TARGET SEGMENT	TARGET DBDNAME
ROOTLEV1	01	1	1		22	80		PTF	ROOTLEV1
								PTB	ROOTLEV1
								PCF	DEP1LEV2
								PCF	DEP2LEV2
								PCF	DEP4LEV2
DEP1LEV2	02	2	1	ROOTLEV1	10	80		PTF	DEP1LEV2
								PTB	DEP1LEV2
DEP2LEV2	03	2	1	ROOTLEV1	14	80		PTF	DEP2LEV2
								PCF	DEP3LEV3
								PCL	DEP3LEV3
DEP3LEV3	04	3	1	DEP2LEV2	10	80		PTF	DEP3LEV3
								PTB	DEP3LEV3
DEP4LEV2	05	2	1	ROOTLEV1	10	80		PTF	DEP4LEV2
								PTB	DEP4LEV2

Figure 147. DBD Summary report for an HDAM database (IPR Unload utility)

The following figure is an example of the DBD Summary report for a HIDAM database.

"DBD SUMMARY"

DATABASE=DBHD0030 ORGANIZATION=HIDAM ACCESS METHOD=ESDS DSGROUPS=1  
PRIMARY INDEX=DBPX0030

SEGMENT	SC	LVL	DSG	PARENT	<-LENGTHS->		<-FLAGS->	<-----POINTER----->	
					PFX LEN	DATA LEN		TARGET SEGMENT	TARGET DBDNAME
ROOTLEV1	01	1	1		26	100	V	PTF	ROOTLEV1
								PTB	ROOTLEV1
								PCF	DEP1LEV2
								PCF	DEP2LEV2
								PCF	DEP3LEV2
								PCL	DEP3LEV2
DEP1LEV2	02	2	1	ROOTLEV1	10	100	V	PTF	DEP1LEV2
								PTB	DEP1LEV2
DEP2LEV2	03	2	1	ROOTLEV1	6	100	V	PTF	DEP2LEV2
DEP3LEV2	04	2	1	ROOTLEV1	34	100	V	PTF	DEP3LEV2
								PTB	DEP3LEV2
								PCF	DEP4LEV3
								PCL	DEP4LEV3
								PCF	DEP5LEV3
								PCL	DEP5LEV3
								PCF	DEP6LEV3
								PCL	DEP6LEV3
DEP4LEV3	05	3	1	DEP3LEV2	10	100	V	PTF	DEP4LEV3
								PTB	DEP4LEV3
DEP5LEV3	06	3	1	DEP3LEV2	10	100	V	PTF	DEP5LEV3
								PTB	DEP5LEV3
DEP6LEV3	07	3	1	DEP3LEV2	10	100	V	PTF	DEP6LEV3
								PTB	DEP6LEV3

Figure 148. DBD Summary report for a HIDAM database (IPR Unload utility)

The following figure is an example of the DBD Summary report for a PHIDAM database.

"DBD SUMMARY"

DATABASE=PHIV0100 ORGANIZATION=PHIDAM ACCESS METHOD=ESDS DSGROUPS=1

SEGMENT	SC	LVL	DSG	PARENT	<- LENGTHS->		VCOXP----	<- FLAGS->	<-----POINTER----->	
					PFX LEN	DATA LEN			TARGET SEGMENT	TARGET DBDNAME
ROOTLEV1	01	1	A		30	20			PTF	ROOTLEV1
									PTB	ROOTLEV1
									PCF	DEP1LEV2
									PCF	DEP2LEV2
									PCF	DEP5LEV2
DEP1LEV2	02	2	A	ROOTLEV1	18	11	0		PTF	DEP1LEV2
									PP	ROOTLEV1
DEP2LEV2	03	2	A	ROOTLEV1	26	21	COX		PTF	DEP2LEV2
									PP	ROOTLEV1
									PCF	DEP3LEV3
									PCL	DEP3LEV3
DEP3LEV3	04	3	A	DEP2LEV2	26	30			PTF	DEP3LEV3
									PP	DEP2LEV2
									PCF	DEP4LEV4
									PCL	DEP4LEV4
DEP4LEV4	05	4	A	DEP3LEV3	18	40			PTF	DEP4LEV4
									PP	DEP3LEV3
DEP5LEV2	06	2	A	ROOTLEV1	22	50			PTF	DEP5LEV2
									PP	ROOTLEV1
									PCF	DEP6LEV3
DEP6LEV3	07	3	A	DEP5LEV2	26	60			PTF	DEP6LEV3
									PP	DEP5LEV2
									PCF	DEP7LEV4
									PCF	DEP8LEV4
DEP7LEV4	08	4	A	DEP6LEV3	18	140	V		PTF	DEP7LEV4
									PP	DEP6LEV3
DEP8LEV4	09	4	A	DEP6LEV3	22	160	V		PTF	DEP8LEV4
									PP	DEP6LEV3
									PCF	DEP9LEV5
DEP9LEV5	0A	5	A	DEP8LEV4	18	200			PTF	DEP9LEV5
									PP	DEP8LEV4

Figure 149. DBD Summary report for a PHIDAM database (IPR Unload utility)

The following figure is an example of the DBD Summary report for a HISAM database.

"DBD SUMMARY"

DATABASE=DBHS0010 ORGANIZATION=HISAM ACCESS METHOD=KSDS

SEGMENT	SC	LVL	DSG	PARENT	<- LENGTHS->		VCOXP----	<- FLAGS->	<-----POINTER----->	
					PFX LEN	DATA LEN			TARGET SEGMENT	TARGET DBDNAME
ROOTLEV1	01	1			2	20				
DEP1LEV2	02	2		ROOTLEV1	2	21	0			
DEP2LEV2	03	2		ROOTLEV1	2	20	C X			
DEP3LEV3	04	3		DEP2LEV2	2	30				
DEP4LEV2	05	2		ROOTLEV1	2	100	V			
DEP5LEV3	06	3		DEP4LEV2	2	200	V			
DEP6LEV3	07	3		DEP4LEV2	2	140	V			

Figure 150. DBD Summary report for a HISAM database (IPR Unload utility)

The meaning of the fields in the DBD Summary report is as follows:

**DATABASE**

Database name.

**ORGANIZATION**

The database organization of the processed database: HISAM, SHISAM, HDAM, HIDAM, PHDAM, or PHIDAM.

**ACCESS METHOD**

The method of getting access to the database: OSAM, ESDS, or KSDS.

**DSGROUPS**

Number of data set groups. For a HISAM or a SHISAM database, this field is not displayed.

**RANDOMIZER**

The randomizer name specified in the DBD parameter (RMNAME=). This field is displayed only for an HDAM database.

**NBR OF RAPS**

The number of root anchor points desired in each control interval or block in the root addressable area of an HDAM database that is specified in the DBD parameter (RMNAME=). This field is displayed only for an HDAM database.

**MAX RBN**

The maximum relative block number value that the user wants to allow a randomizing module to produce for this database that is specified in the DBD parameter (RMNAME=). This field is displayed only for an HDAM database.

**MAX BYTES**

The maximum number of bytes of a database record that can be stored into the root addressable area in a series of inserts unbroken by a call to another database record that is specified in the DBD parameter (RMNAME=). If this value is not specified in DBDGEN, a blank is displayed as the value. This field is displayed only for an HDAM database.

**PRIMARY INDEX**

The primary index name for the HIDAM database. This field is displayed only for a HIDAM database.

**SEGMENT**

The name of the segment type.

**SC**

The segment code. The value is printed in a hexadecimal number, including leading zeros.

**LVL**

The position of a segment in the hierarchy in relation to the root segment.

**DSG**

The data set group number of the segment type. For an HDAM or a HIDAM database, the value is printed in a numeral; for a HISAM or a SHISAM database, a blank; and for a HALDB, in alphabetic characters. In the case of the segment type of the virtual logical child, 0 is displayed.

**PARENT**

The name of the parent segment type.

**<-LENGTHS->****PFX LEN**

The length of the segment prefix in bytes. In the case of the segment type of the virtual logical child, this length is displayed as (VIRTUAL) over the PFX LEN field and the DATA LEN field.

**DATA LEN**

The maximum length of the data portion of a segment type in bytes that is defined in the DBD. In the case of the segment type of the virtual logical child, this length is displayed as (VIRTUAL) over the PFX LEN field and the DATA LEN field.

**<-FLAGS->****VCOXP----**

Segment definition information is indicated by flags. No flags are displayed in the case of the segment type of the virtual logical child.

The meaning of the flags is as follows:

**V:**

The variable-length segment.

**C:**

The compress routine is specified.

- O:**  
The data length is odd byte.
- X:**  
COMPRTN=(,,max) is specified.
- P:**  
COMPRTN=(,,,PAD) is specified.

**<-----POINTER----->**

**TYPE**

The pointer types to be reserved in the prefix area of occurrences of the segment type. These types are not displayed in the case of the HISAM or SHISAM database or the segment type of the virtual logical child.

- CTR:**  
Counter field in prefix
- PTF:**  
Physical twin forward pointer
- PTB:**  
Physical twin backward pointer
- PP:**  
Physical parent pointer
- LTF:**  
Logical twin forward pointer
- LTB:**  
Logical twin backward pointer
- LP:**  
Logical parent pointer
- LCF:**  
Logical child first pointer
- LCL:**  
Logical child last pointer
- PCF:**  
Physical child first pointer
- PCL:**  
Physical child last pointer
- HF:**  
Hierarchic forward pointer
- HB:**  
Hierarchic backward pointer
- ELP:**  
Extended Pointer Set (EPS) for logical parent
- ELC:**  
Extended Pointer Set (EPS) for logical child

**TARGET SEGMENT**

The name of the segment type indicated by the pointer displayed in the TYPE field. In the case of a hierarchic pointer, an asterisk (\*) is displayed.

**TARGET DBDNAME**

When the name of the segment type displayed in the TARGET SEGMENT field is the name of the segment type of another database, the name of the database is displayed.

## HALDB Partitions Processed report

---

This report is written when a HALDB is processed. This report contains information about processed partitions.

The following figure is an example of the HALDB Partitions Processed report.

```
IMS HIGH PERFORMANCE UNLOAD                PAGE:      1
5655-E06                                     10/05/2023 13.11.49

                "HALDB PARTITIONS PROCESSED"

DBDNAME..... PHDV0100
NUMBER OF PARTITIONS DEFINED..... 5
NUMBER OF PARTITIONS PROCESSED... 4
PARTITION SELECTION EXIT..... N/A

LIST OF PARTITIONS ACCESSED

  PHDV01A  PHDV01B  PHDV01C  PHDV01D
```

Figure 151. HALDB Partitions Processed report (IPR Unload utility)

The meaning of the fields in the HALDB Partitions Processed report is as follows:

**DBDNAME**

The DBD name of the database.

**NUMBER OF PARTITIONS DEFINED**

The number of partitions that is defined in the HALDB.

**NUMBER OF PARTITIONS PROCESSED**

The number of partitions that is processed in the HALDB.

**PARTITION SELECTION EXIT**

The name of the partition selection exit, if used. When the high key selection is used, this field shows N/A.

**LIST OF PARTITIONS ACCESSED**

The list of names of the partitions in the HALDB that are processed.

## Segment Count Summary report

---

This report provides the input segments occurrences and the output segment occurrences of each segment type.

The following are examples of Segment Count Summary reports.

This report consists of the following units of information:

- SEGMENT COUNTS IN ENTIRE DATABASE
- NUMBER OF ERRORS IN READING DATABASE
- NUMBER OF ERRORS IN PARTITION SELECTION (Printed only in a HALDB)
- SEGMENT COUNTS IN KEY SEQUENCE ERROR

SEGMENT COUNTS IN KEY SEQUENCE ERROR shows segment information that caused key sequence errors for each segment type, only when there is the specification of KEYCHECK=GX or of KEYCHECK=GG and SKIPERROR=.

If more than one OUTPUT control statement is specified, the previous four units of information are produced for each control statement.

When user exits are used, the unload operation varies depending on the combination of the methods of specifying an OUTPUT control statement and the return codes of the user exits, and therefore, the values of the fields displayed in the report also vary from OUTPUT to OUTPUT. For details, see [Table 58 on page 425](#).

The following figure shows an example Segment Count Summary report of a case in which the following control statement is specified in a NON-HALDB:

**Specification of control statements:**

```
OUTPUT=SYSUT2, SYSUT3, SYSUT4
KEYCHECK=GG
SKIPERROR=10
```

IMS HIGH PERFORMANCE UNLOAD  
5655-E06

PAGE: 1  
10/05/2023 17.49.39

"SEGMENT COUNT SUMMARY"

OUTPUT = SYSUT2, SYSUT3, SYSUT4

SEGMENT COUNTS IN ENTIRE DATABASE

SEGMENT	RETRIEVED	UNLOADED	DELETED BY USER EXIT
ROOTLEV1	15	15	N/A
DEP1LEV2	26	26	N/A
DEP2LEV2	15	15	N/A
DEP3LEV3	11	11	N/A
DEP4LEV2	15	15	N/A
DEP5LEV3	10	10	N/A
DEP6LEV3	121	121	N/A
TOTALS	213	213	N/A

NUMBER OF ERRORS IN READING DATABASE = 12

SEGMENT COUNTS IN KEY SEQUENCE ERROR

SEGMENT	RETRIEVED	NBR OF ERRORS	PCT
ROOTLEV1	15	0	0.0%
DEP1LEV2	26	0	0.0%
DEP2LEV2	15	2	11.8%
DEP3LEV3	11	0	0.0%
DEP4LEV2	15	10	40.0%
DEP5LEV3	10	0	0.0%
DEP6LEV3	121	0	0.0%
TOTALS	213	12	5.3%

Figure 152. Segment Count Summary report for a non-HALDB (IPR Unload utility)

Figure 153 on page 423 shows an example Segment Count Summary report of a case in which the following control statement is specified in a HALDB and in which the following return codes are returned from user exits:

**Specification of control statements:**

```
OUTPUT=SYSUT2
OUTPUT=SYSUT3, , UEXIT1
OUTPUT=SYSUT4, , UEXIT2
KEYCHECK=GX
```

**Return codes from user exits:**

- SYSUT3 user exit returns a return code of 4 to delete the segment.
- SYSUT4 user exit returns a return code of 8 to stop the unload process.

"SEGMENT COUNT SUMMARY"

OUTPUT = SYSUT2

SEGMENT COUNTS IN ENTIRE DATABASE

SEGMENT	RETRIEVED	UNLOADED	DELETED BY USER EXIT
ROOTLEV1	10	10	N/A
DEP1LEV2	10	10	N/A
DEP2LEV2	11	11	N/A
DEP3LEV3	9	9	N/A
DEP4LEV2	22	22	N/A
DEP5LEV3	9	9	N/A
DEP6LEV3	11	11	N/A
TOTALS	82	82	N/A

NUMBER OF ERRORS IN READING DATABASE = 11  
NUMBER OF ERRORS IN PARTITION SELECTION = 0

SEGMENT COUNTS IN KEY SEQUENCE ERROR

SEGMENT	RETRIEVED	NBR OF ERRORS	PCT
ROOTLEV1	10	0	0.0%
DEP1LEV2	10	0	0.0%
DEP2LEV2	11	0	0.0%
DEP3LEV3	9	0	0.0%
DEP4LEV2	22	11	33.3%
DEP5LEV3	9	0	0.0%
DEP6LEV3	11	0	0.0%
TOTALS	82	11	11.8%

"SEGMENT COUNT SUMMARY"

OUTPUT = SYSUT3

SEGMENT COUNTS IN ENTIRE DATABASE

SEGMENT	RETRIEVED	UNLOADED	DELETED BY USER EXIT
ROOTLEV1	10	9	1
DEP1LEV2	10	9	1
DEP2LEV2	11	11	0
DEP3LEV3	9	8	1
DEP4LEV2	22	22	0
DEP5LEV3	9	8	1
DEP6LEV3	11	11	0
TOTALS	82	78	4

NUMBER OF ERRORS IN READING DATABASE = 11  
NUMBER OF ERRORS IN PARTITION SELECTION = 0

SEGMENT COUNTS IN KEY SEQUENCE ERROR

SEGMENT	RETRIEVED	NBR OF ERRORS	PCT
ROOTLEV1	10	0	0.0%
DEP1LEV2	10	0	0.0%
DEP2LEV2	11	0	0.0%
DEP3LEV3	9	0	0.0%
DEP4LEV2	22	11	33.3%
DEP5LEV3	9	0	0.0%
DEP6LEV3	11	0	0.0%
TOTALS	82	11	11.8%

Figure 153. Segment Count Summary report for a HALDB (IPR Unload utility) (Part 1 of 2)

"SEGMENT COUNT SUMMARY"

OUTPUT = SYSUT4

SEGMENT COUNTS IN ENTIRE DATABASE

SEGMENT	RETRIEVED	UNLOADED	DELETED BY USER EXIT
ROOTLEV1	5	5	0
DEP1LEV2	7	7	0
DEP2LEV2	8	8	0
DEP3LEV3	6	6	0
DEP4LEV2	19	19	0
DEP5LEV3	6	5	1
DEP6LEV3	5	5	0
TOTALS	56	55	1

NUMBER OF ERRORS IN READING DATABASE = 11  
NUMBER OF ERRORS IN PARTITION SELECTION = 0

SEGMENT COUNTS IN KEY SEQUENCE ERROR

SEGMENT	RETRIEVED	NBR OF ERRORS	PCT
ROOTLEV1	5	0	0.0%
DEP1LEV2	7	0	0.0%
DEP2LEV2	8	0	0.0%
DEP3LEV3	6	0	0.0%
DEP4LEV2	19	11	36.7%
DEP5LEV3	6	0	0.0%
DEP6LEV3	5	0	0.0%
TOTALS	56	11	16.4%

Figure 154. Segment Count Summary report for a HALDB (IPR Unload utility) (Part 2 of 2)

The meaning of the fields in the Segment Count Summary report is as follows:

**OUTPUT**

DD names of the unload data sets specified in an OUTPUT control statement.

**SEGMENT COUNTS IN ENTIRE DATABASE**

Information about the segments unloaded.

**SEGMENT**

The name of the segment type.

**RETRIEVED**

The number of retrieved segments by segment type. For possible values, see [Table 58 on page 425](#).

**UNLOADED**

The number of unloaded segments by segment type. For possible values, see [Table 58 on page 425](#). If you specify \*NO for the format type of the OUTPUT control statement, N/A is shown.

**DELETED BY USER EXIT**

The number of the segments deleted by a user exit by segment type. For possible values, see [Table 58 on page 425](#). If you specify \*NO for the format type of the OUTPUT control statement, or if USEREXIT is not specified for the OUTPUT control statement, N/A is shown.

**TOTALS**

**RETRIEVED**

The total number of retrieved segments of all segment types.

**UNLOADED**

The total number of unloaded segments of all segment types. If you specify \*NO for the format type of the OUTPUT control statement, N/A is shown.



**DELETED BY USER EXIT**

The total number of the segments of all segment types deleted by a user exit. If you specify \*NO for the format type of the OUTPUT control statement, or if USEREXIT is not specified for the OUTPUT control statement, N/A is shown.

**NUMBER OF ERRORS IN READING DATABASE**

The number of the segments to which status code GG was returned at the time of retrieval.

**NUMBER OF ERRORS IN PARTITION SELECTION**

The number of the segments to which status code GG was returned due to partition selection errors at the time of retrieval. This is produced only in a HALDB.

**SEGMENT COUNTS IN KEY SEQUENCE ERROR**

Information about the segments that caused key sequence errors. This is produced only when KEYCHECK=GX is specified or KEYCHECK=GG and SKIPERROR= are specified.

**SEGMENT**

The name of the segment type.

**RETRIEVED**

The number of retrieved segments by segment type. For possible values, see [Table 58 on page 425](#).

**NBR OF ERRORS**

The number of the segments that caused key sequence errors by segment type.

**PCT**

The percentage of the number of the segments that caused key sequence errors by segment type in segments that were attempted to be retrieved.

**TOTALS****RETRIEVED**

The total number of retrieved segments of all segment types.

**NBR OF ERRORS**

The total number of the segments of all segment types that caused key sequence errors.

**PCT**

The percentage of the number of the segments of all segment types that caused key sequence errors in segments of all segment types that were attempted to be retrieved.

The following table shows the relationship between the return codes from user exits and the values of data fields in the Segment Count Summary report.

*Table 58. Relationship between return codes from user exits and the values of data fields in the Segment Count Summary report*

RC			Report field				
Type-A	Type-B	Meaning of RC	RETRIEVED	UNLOADED	DELETED BY USER EXIT	NUMBER OF ERRORS IN READING DATABASE	NUMBER OF ERRORS IN PARTITION SELECTION
0	0	The segment being processed is written into the unload data set.	Counted.	Counted.	Not counted.	N/A	N/A

Table 58. Relationship between return codes from user exits and the values of data fields in the Segment Count Summary report (continued)

RC			Report field				
Type- A	Type- B	Meaning of RC	RETRIEVED	UNLOADED	DELETED BY USER EXIT	NUMBER OF ERRORS IN READING DATABASE	NUMBER OF ERRORS IN PARTITION SELECTION
-	4	The contents of the segment have been changed. The changed segment is written into the unload data set.	Counted.	Counted.	Not counted.	N/A	N/A
4	8	The segment being processed is deleted (not written out to the unload data set).	Counted.	Not counted.	Counted.	N/A	N/A
8	-	The unload operation on the OUTPUT for which a user exit is specified is stopped.	The segment being processed (the segment to which RC08 was returned) is counted in. Subsequent segments are not counted in for the OUTPUT for which the same user exit as the one that returned RC08 is specified.	The segment being processed (the segment to which RC08 was returned) is not counted in. Subsequent segments are not counted in for the OUTPUT for which the same user exit as the one that returned RC08 is specified.	The segment being processed (the segment to which RC08 was returned) is counted in. Subsequent segments are not counted in for the OUTPUT for which the same user exit as the one that returned RC08 is specified.	Even if there are any segments to which status code GG was returned after the segment to which RC08 was returned, they are not counted in for the OUTPUT for which the same user exit as the one that returned RC08 is specified.	Even if there are any segments to which status code GG was returned due to partition selection errors after the segment to which RC08 was returned, they are not counted in for the OUTPUT for which the same user exit as the one that returned RC08 is specified.

Table 58. Relationship between return codes from user exits and the values of data fields in the Segment Count Summary report (continued)

RC			Report field				
Type- A	Type- B	Meaning of RC	RETRIEVED	UNLOADED	DELETED BY USER EXIT	NUMBER OF ERRORS IN READING DATABASE	NUMBER OF ERRORS IN PARTITION SELECTION
12	12	The segment being processed is deleted, all subsequent segments in this database record are skipped, and the next root segment is retrieved.	The segment being processed (the segment to which RC12 was returned) is counted in. However, this segment (the segment to which RC12 was returned) is not counted in for the subsequent OUTPUTs because the segment is not passed to the OUTPUTs. All subsequent segments in this database record that lie between the segment being processed (the segment to which RC12 was returned) and the next root segment are not counted in because they are skipped.	The segment being processed (the segment to which RC12 was returned) is not counted in. As in the case of RETRIEVE, all subsequent segments in this database record that lie between the segment being processed (the segment to which RC12 was returned) and the next root segment are not counted in because they are skipped.	The segment being processed (the segment to which RC12 was returned) is counted in. As in the case of RETRIEVE, all subsequent segments in this database record that lie between the segment being processed (the segment to which RC12 was returned) and the next root segment are not counted in because they are skipped.	Because all subsequent segments in this database record that lie between the segment being processed (the segment to which RC12 was returned) and the next root segment is skipped, even if there are any segments to which status code GG may be returned, they are not counted in.	Because all subsequent segments in this database record that lie between the segment being processed (the segment to which RC12 was returned) and the next root segment is skipped, even if there are any segments to which status code GG may be returned due to partition selection errors, they are not counted in.

Table 58. Relationship between return codes from user exits and the values of data fields in the Segment Count Summary report (continued)

RC			Report field				
Type- A	Type- B	Meaning of RC	RETRIEVED	UNLOADED	DELETED BY USER EXIT	NUMBER OF ERRORS IN READING DATABASE	NUMBER OF ERRORS IN PARTITION SELECTION
16	-	The segment being processed is deleted, and root segment with the sequence key returned in the Key Area is retrieved.	The segment being processed (the segment to which RC16 was returned) is counted in. However, this segment (the segment to which RC16 was returned) is not counted in for the subsequent OUTPUTs because the segment is not passed to the OUTPUTs. The segments that lie between the segment being processed (the segment to which RC16 was returned) and the root segment with the sequence key returned in the Key Area are not counted in because they are skipped.	The segment being processed (the segment to which RC16 was returned) is not counted in. As in the case of RETRIEVE, the segments that lie between the segment being processed (the segment to which RC16 was returned) and the root segment with the sequence key returned in the Key Area are not counted in because they are skipped.	The segment being processed (the segment to which RC16 was returned) is counted in. As in the case of RETRIEVE, the segments that lie between the segment being processed (the segment to which RC16 was returned) and the root segment with the sequence key returned in the Key Area are not counted in because they are skipped.	Because the segments that lie between the segment being processed (the segment to which RC16 was returned) and the root segment with the sequence key returned in the Key Area is skipped, even if there are any segments to which status code GG may be returned, they are not counted in.	Because the segments that lie between the segment being processed (the segment to which RC16 was returned) and the root segment with the sequence key returned in the Key Area is skipped, even if there are any segments to which status code GG may be returned due to partition selection errors, they are not counted in.

## Segment Statistics report

This report contains information about segments in databases by segment type.

- This report does not show segment types of a virtual logical child.
- For HALDBs, this report is created for each partition.
- For HDAM, PHDAM, and HISAM databases, information about segments in the overflow area or the overflow data set is shown by segment type under the Segment in Overflow Statistics section.

In addition to the basic information about segments, this report contains the following sections:

**Variable Length Segment Statistics section**

When there is any variable-length segment in a database, this section is produced as part of the Segment Statistics report. When there is no variable-length segment, this section is not printed.

For HISAM databases, this section is not printed because no segment split occurs for variable-length segments.

This section shows—for each segment type—information about segments of variable-length segments (including compressed fixed-length segments).

This section does not show segment types of virtual logical child or fixed-length segments.

**Variable Length Segment Split Statistics section**

When there is any variable-length segment in a database, this section is produced as part of the Segment Statistics report. When there is no variable-length segment, this section is not printed.

This section shows—for each segment type—information about segments of split variable-length segments (including compressed fixed-length segments).

This section does not show segment types of virtual logical child or fixed-length segments.

**Twin Segment Statistics section**

This section is always produced as a part of the Segment Statistics report. This section is not printed for HISAM and SHISAM databases.

This section shows statistics about twin chained segments.

The following figures show examples of Segment Statistics reports.

The following figure shows an example Segment Statistic report of a case in which the following conditions are met in a HIDAM database:

- There is no split segment
- There are variable-length segments
- There is no segment type for which a Segment Edit/Compression routine is specified

"SEGMENT STATISTICS"

SEGMENT STATISTICS

SEGMENT	TOTAL NBR OF OCCURRENCES	<-----AVG OCCURRENCES-----> PER PARENT	PER RECORD	AVG SEGM LENGTH	<--CONTRIBUTION TO DB RECORD SIZE--> PCT	CUM SIZE
ROOTLEV1	10	1.0	1.0	56	11.9%	56
DEP1LEV2	13	1.3	1.3	49	13.5%	119
DEP2LEV2	20	2.0	2.0	44	18.8%	207
DEP3LEV2	13	1.3	1.3	75	20.8%	304
DEP4LEV3	13	1.0	1.3	86	23.9%	416
DEP5LEV3	3	0.2	0.3	87	5.6%	442
DEP6LEV3	3	0.2	0.3	87	5.6%	468

TOTAL SEGMENTS = 75

<<< VARIABLE LENGTH SEGMENT STATISTICS >>>

SEGMENT	<-----LENGTHS----->				<-----SEGMENT COUNT----->	<-COMPRESSION-->
	MIN	MAX	PFX	DATA	<MIN =>MIN	FACTOR NAME
ROOTLEV1	20	100	26	30	0	10
DEP1LEV2	20	100	10	39	0	13
DEP2LEV2	20	100	6	38	0	20
DEP3LEV2	20	100	34	41	0	13
DEP4LEV3	20	100	10	76	0	13
DEP5LEV3	20	100	10	77	0	3
DEP6LEV3	20	100	10	77	0	3

<<< VARIABLE LENGTH SEGMENT SPLIT STATISTICS >>>

SEGMENT	<-NUMBER OF OCCURRENCES->		PCT OF	<----PFX + DATA IN---->	
	TOTAL	SPLIT	SPLIT	SAME BLOCK	DIFF BLOCK
ROOTLEV1	10	0	0.0%	0	0
DEP1LEV2	13	0	0.0%	0	0
DEP2LEV2	20	0	0.0%	0	0
DEP3LEV2	13	0	0.0%	0	0
DEP4LEV3	13	0	0.0%	0	0
DEP5LEV3	3	0	0.0%	0	0
DEP6LEV3	3	0	0.0%	0	0
TOTALS	75	0	0.0%	0	0

TWIN SEGMENT STATISTICS

SEGMENT	NUMBER OF CHAINS	MAX CHAIN LENGTH	AVG CHAIN LENGTH
ROOTLEV1	N/A		
DEP1LEV2	2	2	2.0
DEP2LEV2	10	2	2.0
DEP3LEV2	1	3	3.0
DEP4LEV3	0	0	0.0
DEP5LEV3	0	0	0.0
DEP6LEV3	0	0	0.0

Figure 155. Segment Statistics report for a HIDAM database (IPR Unload utility)

The following figure shows an example Segment Statistic report of a case in which the following conditions are met in a PHDAM database:

- There are split segments
- There are variable-length segments
- There is a segment type for which a Segment Edit/Compression routine is specified
- DECOMPRESS=NO is specified

"SEGMENT STATISTICS"

--- PARTITION=PHD001A ---

SEGMENT STATISTICS

SEGMENT	TOTAL NBR OF OCCURRENCES	<-----AVG OCCURRENCES-----> PER PARENT	PER RECORD	AVG SEGM LENGTH	<--CONTRIBUTION TO DB RECORD SIZE--> PCT	CUM SIZE
ROOTLEV1	150	1.0	1.0	243	58.0%	243
DEP1LEV2	150	1.0	1.0	30	7.2%	273
DEP2LEV2	150	1.0	1.0	48	11.4%	320
DEP3LEV3	300	2.0	2.0	49	23.4%	418

SEGMENT IN OVERFLOW STATISTICS

SEGMENT	<-----OVERFLOW-----> NUMBER	PCT
ROOTLEV1	0	0.0%
DEP1LEV2	0	0.0%
DEP2LEV2	0	0.0%
DEP3LEV3	0	0.0%

TOTAL SEGMENTS = 750

<<< VARIABLE LENGTH SEGMENT STATISTICS >>>

SEGMENT	<-----LENGTHS----->				<-----SEGMENT COUNT----->		<-COMPRESSION-->
	MIN	MAX	PFX	DATA	<MIN	=>MIN	FACTOR NAME
ROOTLEV1	200	400	22	221	0	150	
DEP1LEV2	11	13	18	12	0	150	
DEP2LEV2	20	300	26	22	140	10	N/A DFSCMPX0
DEP3LEV3	30	32	18	31	0	300	

<<< VARIABLE LENGTH SEGMENT SPLIT STATISTICS >>>

SEGMENT	<-NUMBER OF OCCURRENCES->		PCT OF	<-----PFX + DATA IN----->	
	TOTAL	SPLIT	SPLIT	SAME BLOCK	DIFF BLOCK
ROOTLEV1	150	15	10.0%	0	15
DEP1LEV2	150	0	0.0%	0	0
DEP2LEV2	150	10	6.7%	10	0
DEP3LEV3	300	0	0.0%	0	0
TOTALS	750	25	3.3%	10	15

TWIN SEGMENT STATISTICS

SEGMENT	NUMBER OF CHAINS	MAX CHAIN LENGTH	AVG CHAIN LENGTH
ROOTLEV1	N/A		
DEP1LEV2	0	0	0.0
DEP2LEV2	0	0	0.0
DEP3LEV3	150	2	2.0

Figure 156. Segment Statistics report for a PHDAM database (IPR Unload utility)

The following figure shows an example Segment Statistic report of a case in which the following conditions are met in a HISAM database:

- There are variable-length segments
- There is a segment type for which a Segment Edit/Compression routine is specified
- DECOMPRESS=YES is specified

"SEGMENT STATISTICS"

SEGMENT STATISTICS

SEGMENT	TOTAL NBR OF OCCURRENCES	<-----AVG OCCURRENCES-----> PER PARENT	PER RECORD	AVG SEGM LENGTH	<--CONTRIBUTION TO DB RECORD SIZE--> PCT	CUM SIZE
ROOTLEV1	10	1.0	1.0	22	5.5%	22
DEP1LEV2	10	1.0	1.0	23	5.7%	45
DEP2LEV2	11	1.1	1.1	25	6.8%	73
DEP3LEV3	9	0.8	0.9	32	7.1%	101
DEP4LEV2	11	1.1	1.1	79	21.6%	189
DEP5LEV3	9	0.8	0.9	121	27.0%	297
DEP6LEV3	11	1.0	1.1	96	26.2%	403

SEGMENT IN OVERFLOW STATISTICS

SEGMENT	<-----OVERFLOW-----> NUMBER	PCT
ROOTLEV1	N/A	N/A
DEP1LEV2	0	0.0%
DEP2LEV2	0	0.0%
DEP3LEV3	0	0.0%
DEP4LEV2	2	18.2%
DEP5LEV3	4	44.4%
DEP6LEV3	8	72.7%

TOTAL SEGMENTS = 71

<<< VARIABLE LENGTH SEGMENT STATISTICS >>>

SEGMENT	<-----LENGTHS----->				<-----SEGMENT COUNT----->		<-COMPRESSION-->
	MIN	MAX	PFX	DATA	<MIN	=>MIN	FACTOR NAME
DEP2LEV2	4	40	2	23	0	11	- 13.6% DFSCMPX0
DEP4LEV2	50	100	2	77	0	11	
DEP5LEV3	100	200	2	119	4	5	
DEP6LEV3	70	140	2	94	0	11	

Figure 157. Segment Statistics report for a HISAM database (IPR Unload utility)

The meaning of the fields in the Segment Statistics report is as follows:

**PARTITION**

The partition name. This field is printed only for a HALDB.

**SEGMENT STATISTICS**

**SEGMENT**

The name of the segment type.

**TOTAL NBR OF OCCURRENCES**

The total number of occurrences by segment type.

**<-----AVG OCCURRENCES----->**

**PER PARENT**

The average number of occurrences of this segment for each occurrence of its parent segment. This is the average twin chain length.

**PER RECORD**

The average number of occurrences of this segment type per database record.

**AVG SEGM LENGTH**

The average length (in bytes) of occurrences by segment type. The length of an occurrence is the sum total of the prefix length and the data length of a segment. When a segment is a variable-length segment (or a compressed fixed-length segment), the average value of the LL fields is used.



**<--CONTRIBUTION TO DB RECORD SIZE-->**

**PCT**

The percentage of the total number of bytes of occurrences of the segment type in the bytes of one database record. This value is shown for each segment type.

**CUM SIZE**

The cumulative average record size (in bytes) up to the layer of the segment type. This value of the last segment type becomes the logical average database record size excluding the bytes padded by IMS.

**SEGMENT IN OVERFLOW STATISTICS**

**SEGMENT**

The name of the segment type.

**<-----OVERFLOW----->**

**NUMBER**

For an HDAM or a PHDAM database, this means the number of segments in the overflow area, and N/A is printed for the segment types in the second and subsequent data set groups.

For an HISAM database, this means the number of segments in the overflow data set, and N/A is printed for the root segment type.

**PCT**

The percentage of the number of the segments in the overflow area of the overflow data set, in all segments for each segment type.

**TOTAL SEGMENTS**

The total number of occurrences of all segment types.

**<<< VARIABLE LENGTH SEGMENT STATISTICS >>>**

**SEGMENT**

The name of the segment type.

**<-----LENGTHS----->**

**MIN**

The minimum segment length (in bytes) by segment type. For details, see [Table 59 on page 433](#).

**MAX**

The maximum segment length (in bytes) by segment type. For details, see [Table 59 on page 433](#).

**PFX**

The prefix length (in bytes) by segment type.

**DATA**

The data length (in bytes) by segment type. When there is any split segment, this includes a total of 6 bytes: the address of the split destination segment, the segment code, and the delete byte.

The following table shows the possible values of MIN and MAX field in the Segment Statistics report for a HISAM Database.

*Table 59. Possible values of MIN and MAX*

MIN or MAX	Variable-Length segment	Compressed Fixed-Length segment with no PAD value specified		Compressed Fixed-Length segment with a PAD value specified	
		MAX value < 10	10 < MAX value	PAD value < value of BYTES= + 10	Value of BYTES= + 10 < PAD value
MIN	<i>minbytes</i> specified in BYTES=.	4		4	

Table 59. Possible values of MIN and MAX (continued)

MIN or MAX	Variable-Length segment	Compressed Fixed-Length segment with no PAD value specified		Compressed Fixed-Length segment with a PAD value specified	
		MAX value < 10	10 < MAX value	PAD value < value of BYTES= + 10	Value of BYTES= + 10 < PAD value
MAX	maxbytes specified in BYTES=.	Length specified in BYTES= + 10.	Length specified in BYTES= + MAX value.	Length specified in BYTES= + 10.	PAD value

**Note:** BYTES=: BYTES= keyword in the SEGM statement of DBDGEN. MAX value: MAX value of the COMPRTN= keyword in the SEGM statement of DBDGEN. PAD value: PAD value of the COMPRTN= keyword in the SEGM statement of DBDGEN.

<-----SEGMENT COUNT----->

<MIN

The number of segments shorter than the minimum segment length of each segment type.

=>MIN

The number of segments longer than the minimum segment length of each segment type.

<-COMPRESSION-->

**FACTOR**

A compression ratio is shown when the segment type is compressed segment. The factor is calculated by the following formula:

$$\frac{(\text{AL of decompressed segment} + \text{PL}) - (\text{AL of compressed segment} + \text{PL})}{(\text{AL of decompressed segment} + \text{PL})} \times 100$$

where: AL: average length PL: prefix length

For a variable-length segment not compressed, a blank is printed.

If DECOMPRESS=NO is specified when the Segment Edit/Compression routine is specified, then N/A is printed.

**NAME**

When the segment type is a compressed segment, the name of the Segment Edit/Compression routine specified in DBD is printed.

For a variable-length segment that is not compressed, a blank is printed.

<<< VARIABLE LENGTH SEGMENT SPLIT STATISTICS >>>

**SEGMENT**

The name of the segment type.

<-NUMBER OF OCCURRENCES->

**TOTAL**

The total number of occurrences by segment type.

**SPLIT**

The total number of split occurrences by segment type.

**PCT OF SPLIT**

The percentage of the number of split occurrences of each segment type in occurrences of the segment type.

**<----PFX + DATA IN---->**

**SAME BLOCK**

The total number of occurrences, by segment type, in which the prefix portion and the data portion are in the same block or in the same CI.

**DIFF BLOCK**

The total number of occurrences, by segment type, in which the prefix portion and the data portion are in different blocks or in different CIs.

**TOTALS**

**<-NUMBER OF OCCURRENCES->**

**TOTAL**

The total number of occurrences of all segment types.

**SPLIT**

The total number of split occurrences of all segment types.

**PCT OF SPLIT**

The percentage of the number of split occurrences of all segment types in occurrences of all segment types.

**<----PFX + DATA IN---->**

**SAME BLOCK**

The total number of occurrences of all segment types in which the prefix portion and the data portion are in the same block or in the same CI.

**DIFF BLOCK**

The total number of occurrences of all segment types in which the prefix portion and the data portion are in different blocks or in different CIs.

**TWIN SEGMENT STATISTICS**

The twin segment statistics section provides statistics about twin chained segments:

**SEGMENT**

The name of the segment.

**NUMBER OF CHAINS**

The total number of twin chain occurrences for the segment type. N/A is shown if a twin pointer is not defined for the segment.

**MAX CHAIN LENGTH**

The maximum length of twin chains.

**AVG CHAIN LENGTH**

The average length of twin chains.

## HDAM Root Addressable Area Statistics report

---

This report contains information about root segments and root anchor points in an HDAM or a PHDAM database.

This report contains information about a randomizing module and randomizing parameters together with the three sections described as follows. For a PHDAM database, this report is created for each partition.

**Key Indicators for Quality of Randomizing section**

This section provides information for checking efficiency of the randomizing module. For the method of checking the efficiency of the randomizing module, see [Chapter 46, "Database tuning guide," on page 629.](#)

**Distribution of HDAM RAP Chain Lengths section**

This section provides a distribution of root segments that are chained by one root anchor point.

**HDAM Root Placement section**

This section provides a distribution of the placement of root segments. Regarding the number of blocks printed both before and after the home block, you can specify it in a HOMECHK control statement.

To disable the output of this section, specify HOMECHK=(0). For details, see [“HOMECHK control statement”](#) on page 373.

The following figure shows an example of the HDAM Root Addressable Area Statistics report.

"HDAM ROOT ADDRESSABLE AREA STATISTICS"

RANDOMIZER=DFSHDC20 NBR OF RAPS=1 MAX RBN=10 MAX BYTES=

<<< KEY INDICATORS FOR QUALITY OF RANDOMIZING >>>

NUMBER OF ROOT SEGMENTS.....	12
NUMBER OF ROOT SYNONYM CHAINS.....	4
NUMBER OF ROOTS PER SYNONYM CHAIN.....	2.0
NUMBER OF ROOTS NOT ON A SYNONYM CHAIN.....	4
NUMBER OF ROOTS ON A SYNONYM CHAIN.....	8
NUMBER OF ROOTS IN LONGEST SYNONYM CHAIN.....	2
NUMBER OF ROOTS NOT IN THE RANDOMIZED BLOCK...	8
NUMBER OF ROOTS PER ROOT ANCHOR POINT.....	1.5
NUMBER OF ROOT ANCHOR POINTS PER ROOT.....	0.8
NUMBER OF ROOT ANCHOR POINTS USED.....	8
NUMBER OF ROOT ANCHOR POINTS NOT USED.....	2
PERCENT OF ROOT ANCHOR POINTS USED.....	80.0%

<<< DISTRIBUTION OF HDAM RAP CHAIN LENGTHS >>>

CHAIN LENGTH	NBR OF CHAINS	NBR OF ROOTS	PCT OF TOTAL ROOTS	CUM OF TOTAL ROOTS
1	4	4	33.3%	33.3%
2	4	8	66.7%	100.0%
3	0	0	0.0%	100.0%
4	0	0	0.0%	100.0%
5	0	0	0.0%	100.0%
6	0	0	0.0%	100.0%
7	0	0	0.0%	100.0%
8	0	0	0.0%	100.0%
9	0	0	0.0%	100.0%
10	0	0	0.0%	100.0%
11+	0	0	0.0%	100.0%

"HDAM ROOT ADDRESSABLE AREA STATISTICS"

<<< HDAM ROOT PLACEMENT >>>

LOCATION	PCT	QUANTITY
- ( 11-)	0.0%	0
- 10	0.0%	0
- 9	0.0%	0
- 8	0.0%	0
- 7	0.0%	0
- 6	0.0%	0
- 5	0.0%	0
- 4	0.0%	0
- 3	0.0%	0
- 2	0.0%	0
- 1	0.0%	0
HOME BLOCK	33.3%	4
+ 1	0.0%	0
+ 2	0.0%	0
+ 3	0.0%	0
+ 4	0.0%	0
+ 5	0.0%	0
+ 6	0.0%	0
+ 7	0.0%	0
+ 8	0.0%	0
+ 9	0.0%	0
+ 10	0.0%	0
+ ( 11-)	0.0%	0
OVERFLOW	66.7%	8

Figure 158. HDAM Root Addressable Area Statistics report for an HDAM database (IPR Unload utility)

The meaning of the fields in the HDAM Root Addressable Area Statistics report is as follows:

**PARTITION**

The partition name. This field is printed only for a PHDAM database.

**RANDOMIZER**

The randomizer name specified in the DBD parameter (RMNAME=). For a PHDAM database, the randomizer name for each partition set in the DBD parameter or the HALDB partition definition.

**NBR OF RAPS**

The number of root anchor points desired in each control interval or block in the root addressable area of an HDAM database that is specified in the DBD parameter (RMNAME=).

For a PHDAM database, the value for each partition set in the DBD parameter or the HALDB partition definition.

**MAX RBN**

The maximum relative block number value that you want to allow a randomizing module to produce for this database and that is specified in the DBD parameter (RMNAME=).

For a PHDAM database, the value for each partition set in the DBD parameter or the HALDB partition definition.

**MAX BYTES**

The maximum number of bytes of a database record that can be stored into the root addressable area in a series of inserts unbroken by a call to another database record and that is specified in the DBD parameter (RMNAME=).

When this value is not specified in DBDGEN, a blank is printed as the value.

For a PHDAM database, the value for each partition set in the DBD parameter or the HALDB partition definition.

**<<< KEY INDICATORS FOR QUALITY OF RANDOMIZING >>>****NUMBER OF ROOT SEGMENTS**

The number of root segments in a database.

**NUMBER OF ROOT SYNONYM CHAINS**

The number of root anchor points to which two or more root segments are chained.

**NUMBER OF ROOTS PER SYNONYM CHAIN**

When the root anchor points to which two or more root segments are chained are considered, the average number of root segments chained.

**NUMBER OF ROOTS NOT ON A SYNONYM CHAIN**

The number of root segments pointed at by root anchor segments that point at only one root segment.

**NUMBER OF ROOTS ON A SYNONYM CHAIN**

The number of root segments chained by the root anchor points to which two or more root segments are chained.

**NUMBER OF ROOTS IN LONGEST SYNONYM CHAIN**

Of the root anchor points to which two or more root segments are chained, the number of root segments chained by the root anchor point to which the most root segments are chained.

**NUMBER OF ROOTS NOT IN THE RANDOMIZED BLOCK**

The number of the root segments that were not placed in the home block (the home block is the block the root segment must be placed in, based on the randomizing routine).

If HOMECHK=(0) is specified, this field shows N/A.

**NUMBER OF ROOTS PER ROOT ANCHOR POINT**

The average number of root segments chained by a root anchor point used (a root anchor point to which at least one root segment is chained).

**NUMBER OF ROOT ANCHOR POINTS PER ROOT**

The average number of root anchor points for each root segment.

**NUMBER OF ROOT ANCHOR POINTS USED**

The number of root anchor points used (to which at least one root segment is chained).

**NUMBER OF ROOT ANCHOR POINTS NOT USED**

The number of root anchor points not used (to which not a single root segment is chained).

**PERCENT OF ROOT ANCHOR POINTS USED**

The percentage of the number of root anchor points used in all root anchor points. (The percentage of use of root anchor points.)

**<<< DISTRIBUTION OF HDAM RAP CHAIN LENGTHS >>>****CHAIN LENGTH**

The range of the number of root segments chained by a root anchor point. (If  $n$  root segments are randomized to a root anchor point, the root anchor point is said to have  $n-1$  synonyms and have a chain length of  $n$ .)

The range is 1, 2, 3, 4, 5, 6, 7, 8, 9, 10, and 11+ (11+ means 11 and over).

**NUMBER OF CHAINS**

The number of root anchor points by CHAIN LENGTH.

**NUMBER OF ROOTS**

The number of root segments by CHAIN LENGTH.

**PCT OF TOTAL ROOTS**

For each CHAIN LENGTH, the percentage of the number of root segments on the CHAIN LENGTH in all root segments.

**CUM OF TOTAL ROOTS**

The cumulative total of PCT OF TOTAL ROOTS up to the CHAIN LENGTH.

**<<< HDAM ROOT PLACEMENT >>>****LOCATION**

The range of the relative locations from the home block for root segments. The home block is the block the root segment must be placed in, based on the randomizing routine. This range must be specified in the HOMECHK control statement.

Other than the range specified in the HOMECHK control statement, the following are printed in LOCATION:

**HOME BLOCK:**

The home block

**OVERFLOW:**

The overflow area

**- (xxx-):**

xxx is 1 less than the maximum number of blocks succeeding the home block specified in the HOMECHK control statement.

**+ (yyy-):**

yyy is 1 more than the maximum number of blocks preceding the home block specified in the HOMECHK control statement.

**PCT**

For each LOCATION, the percentage of the number of root segments in the LOCATION in all root segments.

**QUANTITY**

For each LOCATION, the number of root segments in the LOCATION.

## HDAM RAP Chain I/O Summary report

---

This report contains information about the effectiveness of the randomizer modules of HDAM and PHDAM databases from the viewpoint of database I/O.

The following figure is an example of an HDAM RAP Chain I/O Summary report.

"HDAM RAP CHAIN I/O SUMMARY"

KEY INDICATORS FOR QUALITY OF RANDOMIZING FROM A VIEWPOINT OF DATABASE I/O

AVG NBR OF I/O PER DB RECORD.....	2.91
AVG NBR OF I/O ON RAP CHAIN PER ROOT.....	1.66
AVG NBR OF I/O ON RAP CHAIN PER RAP CHAIN.....	2.00
AVG NBR OF I/O IN ROOT ADDRESSABLE AREA PER DB RECORD...	1.50
AVG NBR OF I/O IN OVERFLOW AREA PER DB RECORD.....	1.41
AVG POSITION OF ROOT SEGMENTS ON RAP CHAINS.....	1.33

OTHER KEY INDICATORS

PACKING DENSITY OF ROOT ADDRESSABLE AREA.....	46.09
---	-------

NBR OF I/O'S REQUIRED TO READ A ROOT SEGMENT RANDOMLY  
(SIMULATED WITH 4 PCB-BUFFERS)

NBR I/O	NBR ROOTS	PCT	CUM PCT
1	4	33.33%	33.33%
2	8	66.66%	100.00%

POSITION OF ROOT SEGMENTS ON RAP CHAINS

POSITION	NBR ROOTS	PCT	CUM PCT
1	8	66.66%	66.66%
2	4	33.33%	100.00%

Figure 159. HDAM RAP Chain I/O Summary report for an HDAM database (IPR Unload utility)

For an HDAM or a PHDAM database, and if DBSTATS=YES is specified, this report is generated together with the HDAM Root Addressable Area Statistics report.

For a PHDAM database, this report is generated together with the HDAM Root Addressable Area Statistics report for each partition.

The meaning of the fields in the HDAM RAP Chain I/O Summary report is as follows:

**KEY INDICATORS FOR QUALITY OF RANDOMIZING FROM A VIEWPOINT OF DATABASE I/O**

**AVG NBR OF I/O PER DB RECORD**

The average number of I/Os required to read all database segments of one database record (see notes [1](#) and [2](#)).

**AVG NBR OF I/O ON RAP CHAIN PER ROOT**

The average number of times of I/O, for each root segment, required to read root segments at random while following the RAP chain (see notes [1](#) and [2](#)).

**AVG NBR OF I/O ON RAP CHAIN PER RAP CHAIN**

The average number of times of I/O, for each RAP chain, required to read root segments at random while following the RAP chain.

**AVG NBR OF I/O IN ROOT ADDRESSABLE AREA PER DB RECORD**

The average number of times of I/O, for each database record, required to read all segments in the root addressable area. This number includes the number of times of I/O required to read root segments and dependent segments in the root addressable area and the number of times of I/O required to follow the RAP chain in the root addressable area.

**AVG NBR OF I/O IN OVERFLOW AREA PER DB RECORD**

The average number of times of I/O, for each database record, required to read all segments in the overflow area. This number includes the number of times of I/O required to read root segments and dependent segments in the overflow area and the number of times of I/O required to follow the RAP chain in the overflow area.



## **AVG POSITION OF ROOT SEGMENTS ON RAP CHAINS**

The average position of the (retrieved) roots on the RAP chains.

## **OTHER KEY INDICATORS**

### **PACKING DENSITY OF ROOT ADDRESSABLE AREA**

The percentage of all segments that consist of two parts (a prefix and the data) in the root addressable area.

### **NBR OF I/O'S REQUIRED TO READ A ROOT SEGMENT RANDOMLY**

#### **(SIMULATED WITH *nnnnn* PCB-BUFFERS)**

The number of buffers to be simulated that is specified in DBSTATS=YES,*nnnnn*.

#### **NBR I/O**

The number of times of I/O required to get a root segment when with the PCB buffer assumed to be *nnnnn*, the root segment is not found on the buffer in a GU call made with root key specification.

The possible values of NBR I/O are 20 ranges: 1, 2, 3, 4, 5, 6, 7, 8, 9, 10, 20, 30, 40, 50, 60, 70, 80, 90, 100, and 101+ (more than 100). However, only the ranges up to the range in which CUM PCT becomes 100.00% are displayed, and no subsequent ranges are displayed.

#### **NBR ROOTS**

For each range, the number of root segments that can be got with a particular number of times of I/O.

#### **PCT**

For each range, the percentage of the number of root segments that can be got with a particular number of times of I/O in the number of all root segments.

#### **CUM PCT**

The cumulative total of PCT up to a particular range.

## **POSITION OF ROOT SEGMENTS ON RAP CHAINS**

### **POSITION**

The position of a root segment in the RAP synonym chain.

The possible values of POSITION are 20 ranges: 1, 2, 3, 4, 5, 6, 7, 8, 9, 10, 20, 30, 40, 50, 60, 70, 80, 90, 100, and 101+ (more than 100). However, only the ranges up to the range in which CUM PCT becomes 100.00% are displayed, and no subsequent ranges are displayed.

### **NBR ROOTS**

For each range, the number of root segments at a particular position.

### **PCT**

For each range, the percentage of the number of root segments at a particular position in the number of all root segments.

### **CUM PCT**

The cumulative total of PCT up to a particular range.

#### **Notes:**

1. When computing database record lengths and the number of I/Os, HSSR Engine takes into account only those database segments that have been retrieved by the application program or utility. The statistic modules of HSSR Engine are not aware of any database records or database segments that have not been retrieved.
2. When computing the number of I/Os, HSSR Engine assumes that the root segment is retrieved through a GU call. HSSR Engine also assumes that at the time the GU call is issued, the buffer pools do not contain any block or CI containing a portion of the RAP chain or containing a database segment of the database record.

When computing the number of I/Os, HSSR Engine attempts to simulate the LRU algorithm of the IMS buffer pools. If, for example, the retrieval of the database segments of one database

record requires access to blocks *n1*, *n2*, and *n3*, or *n2* and *n1*, then HSSR Engine reports that (for a buffer pool of three buffers) the number of I/Os is three (not five).

## Distribution of Database Record Sizes report

This report contains the distribution of the lengths of database records in databases other than SHISAM.

The following figure is an example of the Distribution of Database Record Sizes report.

IMS HIGH PERFORMANCE UNLOAD 5655-E06	PAGE: 1 10/05/2023 13.10.59		
"DISTRIBUTION OF DATABASE RECORD SIZES"			
RANGE	QUANTITY	PCT	CUM PCT
-----	-----	-----	-----
- 100	0	0.0%	0.0%
101 - 200	2	16.7%	16.7%
201 - 300	2	16.7%	33.3%
301 - 400	1	8.3%	41.7%
401 - 500	2	16.7%	58.3%
501 - 600	0	0.0%	58.3%
601 - 700	1	8.3%	66.7%
701 - 800	2	16.7%	83.3%
801 - 900	1	8.3%	91.7%
901 - 1000	0	0.0%	91.7%
1001 - 2000	1	8.3%	100.0%
2001 - 3000	0	0.0%	100.0%
3001 - 4000	0	0.0%	100.0%
4001 - 5000	0	0.0%	100.0%
5001 - 6000	0	0.0%	100.0%
6001 - 7000	0	0.0%	100.0%
7001 - 8000	0	0.0%	100.0%
8001 - 9000	0	0.0%	100.0%
9001 - 10000	0	0.0%	100.0%
10001 -	0	0.0%	100.0%
AVERAGE DATABASE RECORD SIZE =		519	
SHORTEST DATABASE RECORD SIZE =		102	
LONGEST DATABASE RECORD SIZE =		1,096	

Figure 160. Distribution of Database Record Sizes report (IPR Unload utility)

The range of database record size in bytes is specified by the DBRECDIST control statement. If DBRECDIST=0 is specified, this report is not generated. For HALDBs, this report is generated for each partition.

The meaning of the fields in the Distribution of Database Record Sizes report is as follows:

### **PARTITION**

The partition name. This field is printed only for a HALDB.

### **RANGE**

The range of database record size in bytes.

### **QUANTITY**

For each range, the number of database records stored in the range. The database record size used in each range includes the size of the prefix portion and the size of the data portion of each segment.

For variable-length segments (including compressed fixed-length segments), the size of the data portion is calculated as a length that can be actually stored in a database record, including the bytes padded by IMS.

When there is any split segment, this includes a total of 6 bytes for the address of the split destination segment, segment code, and delete byte. However, this does not include the size of the virtual LPCK part.

### **PCT**

For each range, the percentage of the number of database records stored in the range in all database records.

**CUM PCT**

The cumulative total of PCT from the smallest RANGE to a particular RANGE.

**AVERAGE DATABASE RECORD SIZE**

The physical average size of database records including the bytes padded by IMS.

**SHORTEST DATABASE RECORD SIZE**

The physical size of the shortest database record including the bytes padded by IMS.

**LONGEST DATABASE RECORD SIZE**

The physical size of the longest database record including the bytes padded by IMS.

## Largest Database Records report

---

This report contains the largest database records in the database or each HALDB partition.

The following figure is an example of the Largest Database Records report. The number of the listed records can be specified by the DBRECKEYS control statement.

```

IMS HIGH PERFORMANCE UNLOAD
5655-E06
PAGE: 1
08/30/2023 10.42.35

"LARGEST DATABASE RECORDS"

RECORD SIZE      NBR OF
-----      SEGMENTS  ROOT RBA  ROOT KEY
-----
      1,266          15  0000A018  C 03000003
      716           11  00003018  C 05000005
      622            7  0000D018  C 02000002
      470            8  00005018  C 04000004
      460            6  00004018  C 07000007
      216            5  00006018  C 01000001
      148            4  0000E018  C 06000006
  
```

Figure 161. Largest Database Records report

The meaning of the fields in Largest Database Records report is as follows:

**PARTITION**

The partition name. This field is printed only for a HALDB.

**RECORD SIZE**

The database record size including the sizes of the segment prefix portion and the segment data portion for each segment.

- For a variable-length segment (including the compressed fixed-length segment), this includes the bytes padded by IMS.
- For a split segment, this includes a total of 6 bytes for the address of the split destination segment, the segment code, and delete byte. This does not include the size of the virtual LPCK part.

**NBR OF SEGMENTS**

The number of segment occurrences in the database record.

**ROOT RBA**

The RBA of the root segment. If the database is HISAM or SHISAM, this field shows blank.

**ROOT KEY**

The high 32 bytes or 16 bytes of the root key value. The prefix C indicates that it is a character value. Otherwise, the values are shown in hexadecimal representation with the prefix X.

## HISAM Statistics report

---

This report contains the number of logical records in a HISAM database or the chaining information of segments to the overflow data set. It is generated only for a HISAM database.

The following figure is an example of the HISAM Statistics report.

"HISAM STATISTICS"

PRIMARY DD = DDHS0010

NUMBER OF LOGICAL RECORDS.....	10
NUMBER OF RECORDS WITH OVERFLOW CHAINS.....	4
NUMBER OF RECORDS WITH NO OVERFLOW CHAINS...	6
MAX NUMBER OF OVERFLOW CHAINS.....	2
MIN NUMBER OF OVERFLOW CHAINS.....	1
AVERAGE NUMBER OF OVERFLOW CHAINS.....	1.3

OVERFLOW DD = DDH00010

NUMBER OF LOGICAL RECORDS.....	5
--------------------------------	---

Figure 162. HISAM Statistics report (IPR Unload utility)

The meaning of the fields in the HISAM Statistics report is as follows:

**PRIMARY DD**

The ddname of the primary data set in a HISAM database that is specified in the DBD parameter (the DD1= keyword of the DATASET control statement).

**NUMBER OF LOGICAL RECORDS**

The number of logical records that contains segments in the primary data set.

**NUMBER OF RECORDS WITH OVERFLOW CHAINS**

The number of logical records that have pointers to the overflow data set.

**NUMBER OF RECORDS WITH NO OVERFLOW CHAINS**

The number of logical records that do not have pointers to the overflow data set.

**MAX NUMBER OF OVERFLOW CHAINS**

The maximum number of VSAM ESDS roots chained off from one VSAM KSDS root.

**MIN NUMBER OF OVERFLOW CHAINS**

The minimum nonzero number of VSAM ESDS roots chained off from one VSAM KSDS root.

**AVERAGE NUMBER OF OVERFLOW CHAINS**

Average number of VSAM ESDS roots chained off from one VSAM KSDS root (of those with chains).

**OVERFLOW DD**

The ddname of the overflow data set in a HISAM database that is specified in the DBD parameter (the OVFLW= keyword in the DATASET control statement). If an overflow data set is not specified in the DBD, this item is not printed.

**NUMBER OF LOGICAL RECORDS**

The number of logical records that contains segments in the overflow data set. If an overflow data set is not specified in the DBD, this item is not printed.

## Data Set Statistics report

This report contains definition information and statistics information about database data sets.

Figure 163 on page 445 through Figure 165 on page 445 are examples of Data Set Statistics reports.

For a HALDB, this report is generated for each partition. Information about the data set of the primary index and the ILDS data set is not shown in the report for a HALDB.

"DATA SET STATISTICS"

DSG	DDNAME	BLOCK SIZE	RECORD SIZE	DATA SET NAME
1	DDHD0041	4,096	4,096	TESTDS.NTFC5119.DBHD0040.DDHD0041
2	DDHD0042	512	512	TESTDS.NTFC5119.DBHD0040.DDHD0042
3	DDHD0043	1,024	1,024	TESTDS.NTFC5119.DBHD0040.DDHD0043

DSG	DDNAME	FBFF	FSPF	FSPF BYTES	SMALL SEGSZE	LARGE SEGSZE	TOTAL BLOCKS
1	DDHD0041	0	0	0	31	122	501
2	DDHD0042	0	0	0	34	40	3
3	DDHD0043	0	0	0	118	206	5

NUMBER OF BLOCKS IN OVERFLOW = 1

Figure 163. Data Set Statistics report for an HDAM database (IPR Unload utility)

"DATA SET STATISTICS"

--- PARTITION=PHIV01A ---

DSG	DDNAME	BLOCK SIZE	RECORD SIZE	DATA SET NAME
A	PHIV01AA	4,096	4,089	TESTDS.NTFC5114.PHIV0100.A00001
B	PHIV01AB	2,048	2,041	TESTDS.NTFC5114.PHIV0100.B00001
C	PHIV01AC	1,024	1,017	TESTDS.NTFC5114.PHIV0100.C00001

DSG	DDNAME	FBFF	FSPF	FSPF BYTES	SMALL SEGSZE	LARGE SEGSZE	TOTAL BLOCKS
A	PHIV01AA	0	0	0	29	74	11
B	PHIV01AB	0	0	0	48	48	20
C	PHIV01AC	0	0	0	80	80	32

Figure 164. Data Set Statistics report for a PHIDAM database (IPR Unload utility)

"DATA SET STATISTICS"

TYPE	DDNAME	BLOCK SIZE	RECORD SIZE	DATA SET NAME
PRIM	DDHS0010	4,096	370	TESTDS.NTFC5106.DBHS0010.DDHS0010
OVFL	DDH00010	8,192	500	TESTDS.NTFC5106.DBHS0010.DDHS0010

TYPE	DDNAME	SMALL SEGSZE	LARGE SEGSZE
PRIM	DDHS0010	22	202
OVFL	DDH00010	22	202

Figure 165. Data Set Statistics report for a HISAM database (IPR Unload utility)

The meaning of the fields in the Data Set Statistics report is as follows:

**PARTITION**

The partition name. This field is printed only for a HALDB.

**DSG**

The data set group number. For an HDAM or a HIDAM database, this field shows a number; for a HALDB, an alphabet; for a HISAM or a SHISAM database, this field is not printed.

**TYPE**

The type of the database data set of a HISAM database. This field is printed only for a HISAM or a SHISAM database. The value of TYPE means as follows:

**PRIM:**

the primary data set

**OVFL:**

the overflow data set

**DDNAME**

The ddname as coded on the \*1 keyword in the DBD, or the \*2 field registered in RECON as ddname for each data set group (or for each type of database data set in a HISAM or a SHISAM database).

\*1 keyword as follows in each database:

- HDAM: DD1=
- HIDAM: DD1=
- HISAM or SHISAM: DD1=
- HISAM: OVFLW=

\*2 field as follows in each database:

- PHDAM: DDN=
- PHIDAM: DDN=

**BLOCK SIZE**

The block size or the CI size of the database data set for each data set group (or for each type of database data set in a HISAM or a SHISAM database).

**RECORD SIZE**

The logical record length of each data set group (or for each type of database data set in a HISAM or a SHISAM database).

**DATA SET NAME**

The data set name of each data set group (or for each type of database data set in a HISAM or a SHISAM database). For a VSAM data set, only the name of the VSAM cluster is printed.

**FBFF**

The value of the free block frequency factor, of each data set group, specified in the FRSPC=(*fbff, fspf*) keyword of the DBD. This field is printed only for an HDAM, a HIDAM, a PHDAM, or a PHIDAM database.

**FSPF**

The value of the free space percentage factor, of each data set group, specified in the FRSPC=(*fbff, fspf*) keyword of the DBD. This field is printed only for an HDAM, a HIDAM, a PHDAM, or a PHIDAM database.

**FSPF BYTES**

The number of bytes to be removed as free space from the database data set in each data set group. This value is calculated from the values in FSPF (the minimum percentage of each control interval or block that is to be left as free space in this data set group). This field is printed only for an HDAM, a HIDAM, a PHDAM, or a PHIDAM database.

**SMALL SEGSZE**

- For an HDAM, a HIDAM, a PHDAM, or a PHIDAM database:
  - The shortest segment length of all segments that belong to each data set group.
- For a HISAM or a SHISAM database:
  - PRIM: The shortest segment length of all segments.
  - OVFL: The shortest segment length in segments other than the root segment.

The segment length includes both the length of the prefix portion and the data portion. For the length of the data portion, the maximum bytes specified in the BYTES= keyword in the SEGM statement of the DBDGEN—and not the actual length—is used.

### **LARGE SEGSZE**

- For an HDAM, a HIDAM, a PHDAM, or a PHIDAM database:
  - The longest segment length of all segments that belong to each data set group.
- For a HISAM or a SHISAM database:
  - PRIM: The longest segment length of all segments.
  - OVFL: The longest segment length in segments other than the root segment.

The segment length includes both the prefix portion and the data portion. For the length of the data portion, the maximum bytes specified in the BYTES= keyword in the SEGM statement of the DBDGEN—and not the actual length—is used.

When COMPRTN=(,,max) is specified, the length of the data portion is the maximum bytes specified in the BYTES= keyword of the DBD plus 10 (bytes).

### **TOTAL BLOCKS**

The total number of blocks or CIs in each data set group. This field is printed only for an HDAM, a HIDAM, a PHDAM, or a PHIDAM database.

For a VSAM data set, this field does not include record 0.

### **NUMBER OF BLOCKS IN OVERFLOW**

The number of blocks or the number of CIs in the overflow area of an HDAM or a PHDAM database. This field is printed only for an HDAM or a PHDAM database.

## **Buffering and I/O Statistics report**

---

This report contains the actual buffering parameter values used in the run and the statistics on I/O and buffer handler activities.

The following figure shows an example of the Buffering and I/O Statistics report for a non-partitioned database.

"BUFFERING AND I/O STATISTICS"

--- PCB#=#0001 ---

DBNAME = HDAM0010 DS GROUPS = 3 ORG = HDAM ACCESS METHOD = OSAM

\*\*\* BUFFER POOL \*\*\*

BUFFER HANDLER: CAB

BUFFER HANDLER PARAMETERS IN EFFECT:

DDNAME	SIZE OF A BUF	SEQBUF AMOUNT	SEQBUF NUMBER	DIRBUF NUMBER	THRESHOLD PERCENT	ALLOCATE OVFLWBUF	PAGE FIX	NUM OF BUFFERS
HDAMDD10	1,690	24	8	48	100	YES	YES	264
OVFLW	1,690	24	8	48	100		YES	264
HDAMDD20	1,690	24	8	48	100	NO	YES	264
HDAMDD30	1,690	24	8	48	100	NO	YES	264

TOTAL NUMBER OF BYTES IN THIS BUFFER POOL: 1,784,640

\*\*\* I/O STATISTICS \*\*\*

DDNAME	IO DIRECT	IO SEQU	RBA REQUESTS	PCT IO/REQ	PCT IO/BLK
HDAMDD10	5	0	5	100.00	100.00
OVFLW	0	0	0	N/A	.00
HDAMDD20	1	0	1	100.00	50.00
HDAMDD30	1	0	1	100.00	50.00
TOTAL	7	0	7	100.00	

Figure 166. Buffering and I/O Statistics report for a non-partitioned database

The following figure shows an example of the Buffering and I/O Statistics report for a HALDB. This report contains the actual buffering parameter values used in the run and the statistics on I/O and buffer handler activities.



"BUFFERING AND I/O STATISTICS"

--- PCB#=0001 ---

DBNAME = PHIV3800 DS GROUPS = 3 ORG = PHIDAM ACCESS METHOD = ESDS

THE NUMBER OF PARTITIONS DEFINED..... 5  
THE NUMBER OF PARTITIONS ACCESSED..... 3  
MAX NUMBER OF PARTITIONS ACCESSED AT A TIME... 1

\*\*\* BUFFER POOL (DSGROUP=A) \*\*\*

BUFFER HANDLER: CAB

BUFFER HANDLER PARAMETERS IN EFFECT:

DDNAME	SIZE OF A BUF	SEQBUF AMOUNT	SEQBUF NUMBER	DIRBUF NUMBER	THRESHOLD PERCENT	ALLOCATE OVFLWBUF	PAGE FIX
PHIV38CA	512	13	8	26	100	NO	YES
PHIV38DA	512	13	8	26	100	NO	YES
PHIV38EA	512	13	8	26	100	NO	YES

TOTAL NUMBER OF BYTES IN THIS BUFFER POOL: 73,216

\*\*\* I/O STATISTICS (DSGROUP=A) \*\*\*

DDNAME	IO DIRECT	IO SEQU	RBA REQUESTS	PCT IO/REQ	PCT IO/BLK
PHIV38CA	0	1	4	25.00	2.04
PHIV38DA	0	1	4	25.00	2.04
PHIV38EA	0	1	4	25.00	2.04
TOTAL	0	3	12	25.00	

"BUFFERING AND I/O STATISTICS"

--- PCB#=0001 ---

DBNAME = PHIV3800 DS GROUPS = 3 ORG = PHIDAM ACCESS METHOD = ESDS

\*\*\* BUFFER POOL (DSGROUP=B) \*\*\*

BUFFER HANDLER: CAB

BUFFER HANDLER PARAMETERS IN EFFECT:

DDNAME	SIZE OF A BUF	SEQBUF AMOUNT	SEQBUF NUMBER	DIRBUF NUMBER	THRESHOLD PERCENT	ALLOCATE OVFLWBUF	PAGE FIX
PHIV38CB	4,096	6	8	12	100	NO	YES
PHIV38DB	4,096	6	8	12	100	NO	YES
PHIV38EB	4,096	6	8	12	100	NO	YES

TOTAL NUMBER OF BYTES IN THIS BUFFER POOL: 270,336

\*\*\* I/O STATISTICS (DSGROUP=B) \*\*\*

DDNAME	IO DIRECT	IO SEQU	RBA REQUESTS	PCT IO/REQ	PCT IO/BLK
PHIV38CB	0	1	2	50.00	8.33
PHIV38DB	0	1	3	33.33	8.33
PHIV38EB	0	1	2	50.00	8.33
TOTAL	0	3	7	42.85	

Figure 167. Buffering and I/O Statistics report for a HALDB (Part 1 of 2)

"BUFFERING AND I/O STATISTICS"

--- PCB#=0001 ---

DBNAME = PHIV3800 DS GROUPS = 3 ORG = PHIDAM ACCESS METHOD = ESDS

\*\*\* BUFFER POOL (DSGROUP=C) \*\*\*

BUFFER HANDLER: CAB

BUFFER HANDLER PARAMETERS IN EFFECT:

DDNAME	SIZE OF A BUF	SEQBUF AMOUNT	SEQBUF NUMBER	DIRBUF NUMBER	THRESHOLD PERCENT	ALLOCATE OVFLWBUF	PAGE FIX
PHIV38CC	2,048	6	8	12	100	NO	YES
PHIV38DC	2,048	6	8	12	100	NO	YES
PHIV38EC	2,048	6	8	12	100	NO	YES

TOTAL NUMBER OF BYTES IN THIS BUFFER POOL: 135,168

\*\*\* I/O STATISTICS (DSGROUP=C) \*\*\*

DDNAME	IO DIRECT	IO SEQU	RBA REQUESTS	PCT IO/REQ	PCT IO/BLK
PHIV38CC	0	1	3	33.33	4.76
PHIV38DC	0	1	4	25.00	4.76
PHIV38EC	0	1	3	33.33	4.76
TOTAL	0	3	10	30.00	

Figure 168. Buffering and I/O Statistics report for a HALDB (Part 2 of 2)

For each data set group, the following information is printed:

**PCB#**

The sequence number of the PCB, in the PSB, that is used for the database call.

**DBNAME**

The name of the DBD for the database.

**DS GROUPS**

The number of data set groups defined for the database.

**ORG**

The type of the database organization.

**ACCESS METHOD**

The operating system access method (ESDS or OSAM) used for the database.

**Note:** KSDS is buffered by VSAM, not by HSSR buffer handlers.

**DDNAME**

The ddname as coded on the \*1 keyword in the DBD, or the \*2 field registered in RECON as ddname.

\*1 keyword as follows in each database:

- HDAM: DD1=
- HIDAM: DD1=
- HISAM: OVFLW=

\*2 field as follows in each database:

- PHDAM: DDN=
- PHIDAM: DDN=

**SIZE OF A BUF**

Buffer size in bytes.

**SEQBUF AMOUNT**

The number of buffers in a sequential buffer.

**SEQBUF NUMBER**

The number of sequential buffers allocated for the DDNAME.

**DIRBUF NUMBER**

The number of direct buffers allocated for the DDNAME.

**THRESHOLD PERCENT**

The reference threshold value (in percentage) for determining whether chained sequential I/O or direct I/O must be performed.

**ALLOCATE OVFLWBUF**

This indicates if or not a separated buffer is allocated for the overflow area of the data set identified by the DDNAME.

**NUM OF BUFFERS**

Total number of bytes allocated for the buffer for the data set identified by the DDNAME.

**IO DIRECT**

The number of direct I/O requests issued.

**IO SEQU**

The number of sequential I/O requests chained.

**RBA REQUESTS**

The number of buffer handler requests for RBAs in the data set range identified by the DDNAME column.

**PCT IO/REQ**

The percentage of I/O operations issued per buffer handler request.

**PCT IO/BLK**

The percentage of I/O operations issued per number of blocks or CIs contained in the data set.

**TOTAL**

The total of all the preceding fields. The TOTAL row appears once on the report.

## HALDB Partition Definition report

The report shows the definition information about a HALDB. It is generated only for a HALDB.

This section contains examples of HALDB Partition Definition reports.

**Note:** If you specify PARTINFO=NO, the report is not generated even for HALDBs.

The following figure shows an example of a case where the high key selection is defined. The keys used are in hexadecimal.

IMS HIGH PERFORMANCE UNLOAD 5655-E06	PAGE: 1 10/05/2023 11.20.56
"HALDB PARTITION DEFINITION"	
PARTITIONS LISTED IN ORDER OF HIGH KEY	
SEQ PARTITION	ID PARTITION HIGH KEY
-----	
0001 PHDV30A	1 X'F1F0F0F0F0F0F0'
0002 PHDV30B	2 X'F3F0F0F0F0F0F0'
0003 PHDV30C	3 X'F5F0F0F0F0F0F0'
0004 PHDV30D	4 X'F7F0F0F0F0F0F0'
0005 PHDV30E	5 X'FFFFFFFFFFFFFF'

Figure 169. HALDB Partition Definition report when the high key selection is defined (IPR Unload utility)

The following figure shows an example of a case where the partition selection exit is defined. The keys used are in character.

"HALDB PARTITION DEFINITION"

PARTITIONS LISTED IN ORDER OF PARTITION NAME

SEQ	PARTITION	ID	PARTITION SELECTION STRING
0001	PHD003A	1	C '19999999'
0002	PHD003B	2	C '39999999'
0003	PHD003C	3	C '59999999'
0004	PHD003D	4	C '79999999'
0005	PHD003E	5	C '99999999'

Figure 170. HALDB Partition Definition report when the partition selection exit is defined (IPR Unload utility)

The meaning of the fields in the HALDB Partition Definition report is as follows:

**PARTITIONS LISTED IN ORDER OF HIGH KEY**

This is printed only when the high key selection is defined.

**PARTITIONS LISTED IN ORDER OF PARTITION NAME**

This is printed only when the partition selection exit is defined.

**SEQ**

The sequence number. They are printed in the order of the key when the high key selection is defined. They are printed in the order of the partition name when the partition selection exit is used.

**PARTITION**

The partition name defined by the IMS HALDB Partition Definition utility.

**ID**

The partition ID number.

**PARTITION HIGH KEY**

The value of the high key. It is printed only when the high key selection is defined.

- In character, if TYPE=C is specified for the Root Sequence Key Field in DBDGEN, and if character representation is possible. Otherwise, in hexadecimal representation.
- In hexadecimal representation, if anything other from TYPE=C has been specified for Root Sequence Key Field in DBDGEN.

**PARTITION SELECTION STRING**

The value of the partition selection string. It is printed only when the partition selection exit is defined.

This field checks whether each partition of a database can be displayed in character, and does so if possible. Otherwise, it displays it in hexadecimal representation.

## HDAM RAPCHECK Incorrect RAP Chain report

If RAPCHECK=YES is specified in the HPSIN data set and one or more incorrect RAPs are detected in the RAP check, this report is generated in the HPSRAPC data set.

The following figure is an example of an HDAM RAPCHECK Incorrect RAP Chain report.

"HDAM RAPCHECK INCORRECT RAP CHAIN"

```
CURRENT RAP RBA: X'0027D014'  
CORRECT RAP RBA: X'0027E014'   RANDOMIZED BBR: X'00027E05'  
  SEGMENT RBA: X'0027DE7A'  
  SEGMENT KEY: (LENGTH= 16 DECIMAL)  
                F8F1F8F9 F8F5F5F0 F0F8F5F4 F5D14040          *8189855008545J *  
  
CURRENT RAP RBA: X'0027D018'  
CORRECT RAP RBA: X'0027E018'   RANDOMIZED BBR: X'00027E06'  
  SEGMENT RBA: X'01976DE6'  
  SEGMENT KEY: (LENGTH= 16 DECIMAL)  
                F3F2F3F7 F7F8F2F1 F8F9F3F9 F3C94040          *3237782189393I *  
  
TOTAL ROOT SEGMENTS CHAINED FROM INCORRECT RAPS =                2
```

Figure 171. HDAM RAPCHECK Incorrect RAP Chain report

**CURRENT RAP RBA**

The RBA of the incorrect RAP detected in the RAP check.

**CORRECT RAP RBA**

The RBA of the expected RAP that is obtained from the result of the randomizing module.

**RANDOMIZED BBR**

The result of the randomizing module in the form BBR. BBB is RBN or the CI number, and R is a RAP number.

**SEGMENT RBA**

The RBA of the root segment chained off from the current RAP.

**SEGMENT KEY**

The key of the root segment.



## Chapter 29. User exits for IPR Unload

The user exit gives you additional selectivity or enables you to modify segments before the segment data is written into the output data set. You can also control the IPR Unload utility using various return codes from your exit routine.

Two types of user exit interfaces are supported:

- Type-A user exit
- Type-B user exit

**Warning:** When you are reorganizing PHDAM or PHIDAM in the Smart Reorg utility, be careful when using the user exits to change the key values of the root segment. Because the HALDB selects partitions by the value of the root segment key, the partitions selected might be changed if you change the key values of the root segment. You cannot make changes that cause partition changes. Incorrect key changes for the root segment might cause an IPR Reload utility error.

This topic describes the interface of the user exits for the IPR Unload utility. It is a product-sensitive programming interface.

### Topics:

- [“Type-A user exit” on page 455](#)
- [“Type-B user exit” on page 456](#)

## Type-A user exit

The Type-A user exit is the default user exit for the IPR Unload utility and it is exactly the same as the user exit for FABHFSU unload utility of IMS HP Unload except for how to specify the exit options.



See the following table.

Table 60. Comparison of Type-A exit routine options

Exit routine option	In IPR Unload utility	In FABHFSU
Name of exit routine	specified by the third parameter of the OUTPUT control statement in HPSIN data set	specified in column 24 of a PSB control statement in the CARDIN data set
Concatenated key option	fourth parameter ( <i>key</i> ) of the OUTPUT statement	column 33 of the PSB statement
	YES	Y
	No (default)	N or blank (default)
Exit routine control option	fifth parameter ( <i>control</i> ) of the OUTPUT statement	column 34 of the PSB statement
	YES	Y
	NO (default)	N or blank (default)
DBR skip option	sixth parameter ( <i>dbrskip</i> ) of the OUTPUT statement	in column 35 of the PSB statement
	YES	Y
	No (default)	N (default)

Table 60. Comparison of Type-A exit routine options (continued)

Exit routine option	In IPR Unload utility	In FABHFSU
Segment modification option	seventh parameter ( <i>ext</i> ) of the OUTPUT statement	column 32 of the PSB statement
	YES	E
	not supported (specify YES instead)	Y
	No (default)	N or blank (default)
Extension length	eighth parameter ( <i>ext_len</i> ) of the OUTPUT statement	columns 41-45 of the PSB statement
Data conversion option	ninth parameter ( <i>conv</i> ) of the OUTPUT statement	column 36 of the PSB statement
	YES	Y
	No (default)	N (default)

For details of the user exit, see the *IMS High Performance Unload User's Guide* and refer to the topic that explains about user exits.

PSPI

## Type-B user exit

Type-B user exit has the interface simpler than the Type-A user exit.

### Attributes of the routine

PSPI

#### Link-Editing the routine

It is recommended that the exit routine is linked as AMODE=31, but the exit routines of AMODE=24 are also supported. When you are reorganizing a database in the Smart Reorg utility, the exit routine must be link-edited in 31-bit addressing mode (AMODE 31).

#### Loading the routine

The exit routine must be in a STEPLIB library available to the unload job step because the IPR Unload utility dynamically loads it.

#### Activating the routine

The exit routine is called each time a segment is retrieved and before it is written into the output data set. The exit routine is called once more at termination.

### Communicating with IPR Unload utility

This topic describes how to communicate with IPR Unload utility.

#### Contents of registers on entry

Table 61 on page 457 through Table 63 on page 457 show the contents of the register upon entry to the Type-B exit routine:



Table 61. Register contents upon entry to the Type-B user exit

Register	Content
1	Pointer to the parameter list.
13	Pointer to the register save area
14	Return address
15	Entry point address of the routine

### Description of parameters

Table 62. Parameter list pointed to by Register 1 upon entry to the Type-B user exit

Word	Description
1	<p>Pointer to the 12-byte area that contains an 8-byte segment name, a 1-byte segment code, a 1-byte segment level code, and a 2-byte (halfword binary) segment data length. The length is the length of the data pointed to by the second parameter.</p> <p>The routine is called before each unload segment record is written in the unload data set or the data sets specified by the <i>ddname</i> parameter of the OUTPUT statement.</p> <p>The exit routine is called one more time at termination. At termination, the segment name contains blanks and the segment code contains a binary zero.</p>
2	<p>Pointer to the segment data that is to be written to the unload data set. If the DECOMPRESS=NO is in effect, the data is in compressed format.</p> <p><b>Note:</b> The segment length must not be changed in this area. For details, see "Modifying segments in user exits" in this topic.</p>
3	Pointer to a segment work area large enough to hold the largest possible segment defined in the DBD being used.
4	Pointer to the HSSR PCB. For the HSSR PCB mask, see <a href="#">"Interpreting PCB feedback"</a> on page 467.

### Contents of registers on exit

At return to the caller, the Register 15 must contain one of the following return codes:

Table 63. Return codes

Return code	Description
0	<p>Use the segment pointed to by parameter 2.</p> <p>If no changes are made to the segment in the exit routine, Register 15 must be set to 0.</p>
4	<p>Use the modified segment pointed to by parameter 3.</p> <p>If the segment is copied to the work area pointed to by parameter 3 and is modified, Register 15 must be set to 4.</p>
8	<p>Delete the segment.</p> <p>When deleting a segment, it is your responsibility to also delete all hierarchically dependent segments; that is, a return code of 8 should also be returned for each dependent segment.</p>

---

Table 63. Return codes (continued)

---

Return code	Description
12	Delete the segment and skip all subsequent segments in this database record.  The IPR Unload utility skips the dependent segments under this parent and skips the rest of the segments, in this database record, that are placed hierarchically after the deleted segment. If this code is returned, the IPR Unload utility skips the segment data, and jumps to the next root segment.
100 - 999	Delete the segment and stop the retrieval of remaining segments.  The IPR Unload utility, after calling the exit once more at termination, sets the returned code as the job-step return code.

---

If a return code that is not described in the table is returned, the IPR Unload utility abends.

### How the exit routine works

The IPR Unload utility invokes the user exit routine for each segment before it places them into the output data set. The exit is invoked once more at termination.

#### DECOMPRESS option and user exit

If the data is compressed in the database and you specify that you want to expand compressed segments with the DECOMPRESS=YES option, the IPR Unload utility automatically expands the data before passing it to the exit. If you do not specify DECOMPRESS=YES, the data is passed to the exit in the compressed format.

When you are using the user exit for fixed-length segments with compression, the following rules apply:

- If the data is in the decompressed format, do not specify the length field when moving the modified data into the work area pointed to by the third parameter.
- If the data is in the compressed format, specify the length field when moving the modified data into the work area.

#### Data Conversion Exit (DFSDBUX1 Exit) and user exit

If DATXEXIT=YES is specified and the DFSDBUX1 Data Conversion exit routine is being called, the data passed to the exit routine is in the application image, not in the stored image.

#### Deleting segment data and removing a segment type

You can use a user exit to delete the segment data. If you are removing a segment type from a DBD, you must delete all occurrences of the segment data from the unload file before you reload the file.

#### Modifying segments in user exits

If the segment data is to be used without change, set the return code to 0.

When you modify a segment, you must copy the segment data from the area pointed to from the second parameter to the area pointed to from the third parameter, change the data in the latter area, and set the return code to 4.

When you delete a segment, it is your responsibility to also delete all hierarchically dependent segments or set the return code to 12.

If a change for segment length is required, the work area whose address is passed as the third parameter must be used. Because the amount of segment data placed into the unload data set is controlled by the segment size in the DBD, segments can be extended only if they are defined in the DBD as variable length. The segment size must not be larger than the size of the largest segment in the DBD.

When moving the segment areas from one area to another, make sure that you move only the length of the current segment.

Segments defined as fixed-length in the DBD cannot be expanded by the user exit. If you want to expand fixed-length segments, a Type-A user exit routine should be used.

**Consideration for the sequence of segment data in the output data set**

The IPR Unload utility unloads the segments and passes them to the user exit routine in hierarchical sequence. If your exit routine changes the value of the key fields, you must sort the segments back into the hierarchical sequence before they are reloaded.





---

# Chapter 30. Application programming interface for IPR Unload utility

The IPR Unload utility provides an application programming interface (API).

API for the IPR Unload utility enables an IMS batch DL/I application program that reads a database sequentially to use HSSR Engine of IMS HP Unload. This enables the application program to benefit from the high-performance segment retrieval processing of HSSR Engine.

## Topics:

- [“Overview” on page 461](#)
- [“Preparing and running application program” on page 462](#)
- [“System flow of the API function” on page 467](#)
- [“PCB feedback information” on page 467](#)
- [“Restrictions” on page 471](#)
- [“JCL requirements” on page 472](#)
- [“Control statements for the API function” on page 474](#)
- [“JCL examples for the API function” on page 476](#)
- [“Reports and statistics produced by the API function” on page 478](#)
- [“Compatibility considerations” on page 479](#)

---

## Overview

The following topics explain IMS batch DL/I application programs that can benefit from HSSR Engine by using the API for the IPR Unload utility.

### HSSR application program

By using the API, batch DL/I application programs that read primarily large portions of a database sequentially can significantly reduce the elapsed time and the CPU time.

The API is *not* a replacement for the DL/I API; It is optimized for GN call processing. Consider the API as an extension of the unload process. Using the API, the application programs can retrieve segments more efficiently than with using the DL/I.

A batch DL/I application program that uses HSSR Engine for processing DL/I database calls is called an *HSSR application program*. A PCB specified to be serviced by HSSR Engine is called an *HSSR PCB*. For details about how to specify an HSSR PCB, see [“Specifying an HSSR PCB” on page 466](#). A buffer pool is allocated by HSSR Engine for each data set group of the database for which the HSSR PCB is used. Each DL/I call or EXEC DLI command to the HSSR PCB (called an *HSSR call*) is processed by HSSR Engine. If the PCB is not an HSSR PCB, HSSR Call Router passes control to the DL/I program request handler.

### Application program that can benefit from HSSR Engine

An IMS DL/I batch application program that reads a database almost sequentially can run, by using the IPR Unload utility, without being recompiled or relink-edited because the HSSR calls are transparent to DL/I.

Not every IMS application program can, however, be run as an HSSR application program. Running the application program by the IPR Unload utility reduces the elapsed time and CPU time for retrieving a large number of segments sequentially. But do not use it to retrieve, for example, only a few thousand segments. HSSR Engine is optimized for GN and GNP calls with unqualified segment search arguments

(SSAs) calls. Unless you issue several GN or GNP calls for each GU call, do not run your application program by using the IPR Unload utility.

**Note:** If APISET=2 is specified, a GN or a GNP call with an unqualified SSA that contains the name of a dependent segment type can be processed by HSSR Engine. If APISET=3 is specified, you can issue other types of DL/I calls. But if HSSR Call Analyzer encounters a DL/I call that is not supported by APISET=2, that call and all succeeding calls are processed by DL/I, not by HSSR Engine. IBM recommends that you use APISET=1 or 2 for application programs running on the IPR Unload utility and that, if your application program issues a call not supported by APISET=2, you use native IMS instead.

## Preparing and running application program

---

This topic describes the steps for preparing and running an application program.

### Procedure

To run an HSSR application program, do the following:

1. Select a region type; DLI, DBB, or ULU.
2. If you selected region type DLI or DBB, prepare a PSB for the application program.
3. Write an application program by coding DL/I calls or HSSR call statements supported by the API.
4. Assemble or compile the application program, and link-edit it.
5. Specify an HSSR PCB for which HSSR Engine is to be used, and run the IPR Unload utility job for the application program.

### Selecting a region type

The API supports three IMS batch region types: DLI, DBB, and ULU.

#### About this task

For details, see [“EXEC statement” on page 472](#).

### Preparing a PSB

To run an HSSR application program in the DLI or DBB region, you must prepare a PSB. In the PSB, at least one *HSSR-eligible PCB*, explained later in this topic must be coded.

#### About this task

Only the HSSR-eligible PCB can be specified as *an HSSR PCB*. An HSSR PCB is a PCB to which DL/I calls and EXEC DLI commands are processed by HSSR Engine. An HSSR PCB is specified by the PCB and the PCBNAME control statements. For the details of these control statements, see [“PCB and PCBNAME control statements” on page 475](#).

*An HSSR-eligible PCB* must satisfy all requirements described in the following topic.

### PCB statement requirements

This topic summarizes the PCB statement requirements.

- The DBDNAME (or NAME) parameter must specify the name of a physical DBD. The name must not be the name of a logical DBD.
- LIST=NO option must not be specified.

## Processing option (PROCOPT) requirements

The PROCOPT parameter must specify one or certain combinations of codes summarized in the following table.

The following table contains all the PROCOPT values that are supported by the IPR Unload API.

For more information about PROCOPT parameters of the PCB statement, see the topic "Full-function or Fast Path database PCB statement" in *IMS System Utilities*.

Table 64. Processing option (PROCOPT)

Code	Description
PROCOPT=G	Get function. If a database is shared at the database level when PROCOPT=G, DBRC grants access with read integrity. It prevents the concurrent execution of the application program and the updating by the IMS subsystem.
PROCOPT=O	Read only. (Use this code with G.) If a database is shared at the database level when PROCOPT=GO, DBRC grants access without read integrity. It enables the application program to run and the IMS subsystem to update the database concurrently.
PROCOPT=N	Read only. (Use this code with GO.) N allows the application program to avoid abends when referring to data that is being updated by another program. A GG status code is returned, and the program must decide whether to end or to continue.
PROCOPT=T	Read Only. (Use this code with GO.) T works similarly as N, except that it causes DL/I to retry the operation automatically before returning the GG status code.
PROCOPT=E	Enables exclusive use of the database or segment. (Use this code with G.) If a database is shared at the database level when PROCOPT=GE, DBRC grants exclusive use to the database.

If you want to use PROCOPT=GON or GOT, see the *IMS High Performance Unload User's Guide* and refer to the topic that explains the consideration for database sharing when an HSSR application program is running.

### Notes:

- PROCOPT=A is also accepted, however, is not recommended. Even if PROCOPT=A is specified, HSSR engine is treated as PROCOPT=G.
- PROCOPT=P is also accepted, however, is not recommended. Even if PROCOPT=P is specified, D command code is not processed by HSSR engine.

## SENSEG statement requirements

The following conditions must be satisfied:

- SENSEG statements must be coded in the same hierarchical sequence as is defined in the DBD.
- Field sensitivity must not be specified.
- Either the PROCOPT field must be omitted in the SENSEG statements; or, if it is coded, the processing option must be G, GE, or K.

## Coding DL/I calls and EXEC DLI commands for HSSR PCB

An HSSR call is a DL/I call or an EXEC DLI command that is issued against an HSSR PCB. Each HSSR call is processed by HSSR Engine.

### Procedure

The HSSR call is issued through the DL/I language interface, but the call is transferred to the HSSR Call Analyzer. The call is finally processed by either HSSR Call Handler or DL/I, depending on the type of the call and the API set specified.

If APISET=1 (default) or 2 is specified and an unsupported call is issued against an HSSR PCB, HSSR Engine ends abnormally. In this case, to continue the processing by DL/I, you can specify APISET=3.

You can specify an API set by making it the site default or by including an APISET control statement in the HPSIN DD statement. For details, see “APISET control statement” on page 475 and Chapter 45, “Setting installation default options,” on page 617.

### Call types supported by each API set

The IPR Unload utility supports three API sets.

APISET=1 is the system default. The following table shows the DL/I call types supported by each API set, and their effects with and without segment search arguments (SSAs):

Table 65. DL/I call types supported by each API set

API set	Call types supported
APISET=1	<p>The following call types are supported:</p> <ul style="list-style-type: none"><li>• GU and GHU calls without SSA: the first root segment of the database is retrieved.</li><li>• GU and GHU calls with an SSA that is qualified on the root sequence key. In the SSA, any one of the following relational operators is available:<ul style="list-style-type: none"><li>– equal-to (=b,b=, or EQ. b represents a single blank)</li><li>– greater-than-or-equal-to (&gt;=,=&gt;,or GE)</li></ul></li><li>• GN and GHN calls without SSAs.</li><li>• GN and GHN calls with an unqualified SSA that contains the name of a root segment type.</li><li>• GN and GHN calls with an SSA that is qualified on the root sequence key. In the SSA, any one of the following relational operators is available:<ul style="list-style-type: none"><li>– equal-to (=b,b=, or EQ)</li><li>– greater-than-or-equal-to (&gt;=,=&gt;, or GE)</li><li>– greater-than (&gt;b,b&gt;, or GT)</li></ul></li></ul> <p>These calls are not supported for HDAM or PHDAM database.</p> <ul style="list-style-type: none"><li>• GNP and GHNP calls without SSAs.</li></ul>
APISET=2	<p>The following call types are supported for HD and partitioned HD databases in addition to the call types supported in APISET=1:</p> <ul style="list-style-type: none"><li>• GN and GHN calls with an unqualified SSA that contains the name of a dependent segment type.</li><li>• GNP and GHNP calls with an unqualified SSA that contains the name of a dependent segment type.</li></ul>



Table 65. DL/I call types supported by each API set (continued)

API set	Call types supported
APISET=3	The fully supported call types are the same as those in APISET 2. Once an unsupported call is issued for an HD database or a partitioned HD database, the call and all the succeeding calls to the HSSR PCB are passed to the IMS DL/I call handler to continue the processing instead of ending it abnormally.

## EXEC DLI command types supported by each API set

The IPR Unload utility supports three API sets.

APISET=1 is the system default. The following table shows the EXEC DLI command types supported by each API set, and their effects with and without the SEGMENT options:

Table 66. EXEC DLI command types supported by each API set

API set	Call types supported
APISET=1	<p>The following call types are supported:</p> <ul style="list-style-type: none"> <li>• GU command with a SEGMENT option and a WHERE option qualified on the root sequence key. In the WHERE option, any one of the following relational operators is available: <ul style="list-style-type: none"> <li>– equal-to (=b,b=, or EQ. b represents a single blank)</li> <li>– greater-than-or-equal-to (&gt;=,=&gt;, or GE)</li> </ul> </li> <li>• GN command without SEGMENT options.</li> <li>• GN command with a SEGMENT option that contains the name of a root segment type.</li> <li>• GN command with a SEGMENT option and a WHERE option qualified on the root sequence key. In the WHERE option, any one of the following relational operators is available: <ul style="list-style-type: none"> <li>– equal-to (=b,b=,or EQ)</li> <li>– greater-than-or-equal-to (&gt;=,=&gt;, or GE)</li> <li>– greater-than (&gt;b,b&gt;, or GT)</li> </ul> <p>This is not supported for HDAM or PHDAM database.</p> </li> <li>• GNP command without SEGMENT options.</li> </ul>
APISET=2	<p>The following command types are supported for HD and partitioned HD databases in addition to the command types supported in APISET=1:</p> <ul style="list-style-type: none"> <li>• GN command with a SEGMENT option that contains the name of a dependent segment type.</li> <li>• GNP command with a SEGMENT option that contains the name of a dependent segment type.</li> </ul>
APISET=3	The fully supported command types are the same as those in APISET 2. Once the unsupported command is issued for an HD database or a partitioned HD database, the command and all the succeeding commands to the HSSR PCB are passed to the IMS DL/I call handler to continue the processing instead of ending it abnormally.

An HSSR call gives the same results as a DL/I call or an EXEC DLI command, with some minor differences. For details, see [“PCB feedback information” on page 467](#). For a complete description of the commands, options, and layout of the DL/I interface block (DIB) and qualified commands, see *IMS Application Programming*.

## The structure of the application program

The application program has the same structure as the DLIBATCH application program.

You can also issue a DL/I call for a DL/I PCB, other than HSSR calls, in your application program. DL/I calls for DL/I PCBs are processed by IMS, not by HSSR Engine.

## Creating the application program

An application program that issues HSSR calls must be assembled, compiled, and link-edited in the same way as the IMS DL/I batch application programs.

### About this task

For details, see *IMS Application Programming*.

## Specifying an HSSR PCB

If you run your HSSR application program in a DLI or a DBB region, you need to specify the PCB for which HSSR Engine is used.

### Procedure

To do this, code the PCB or PCBNAME control statement. For details about these control statements, see [“Control statements for the API function” on page 474](#).

If you run your HSSR application program in the ULU region, you do not need to code the PCB or the PCBNAME control statements.

## System flow of the API function

The following figure shows the overview of the system flow of the API function.

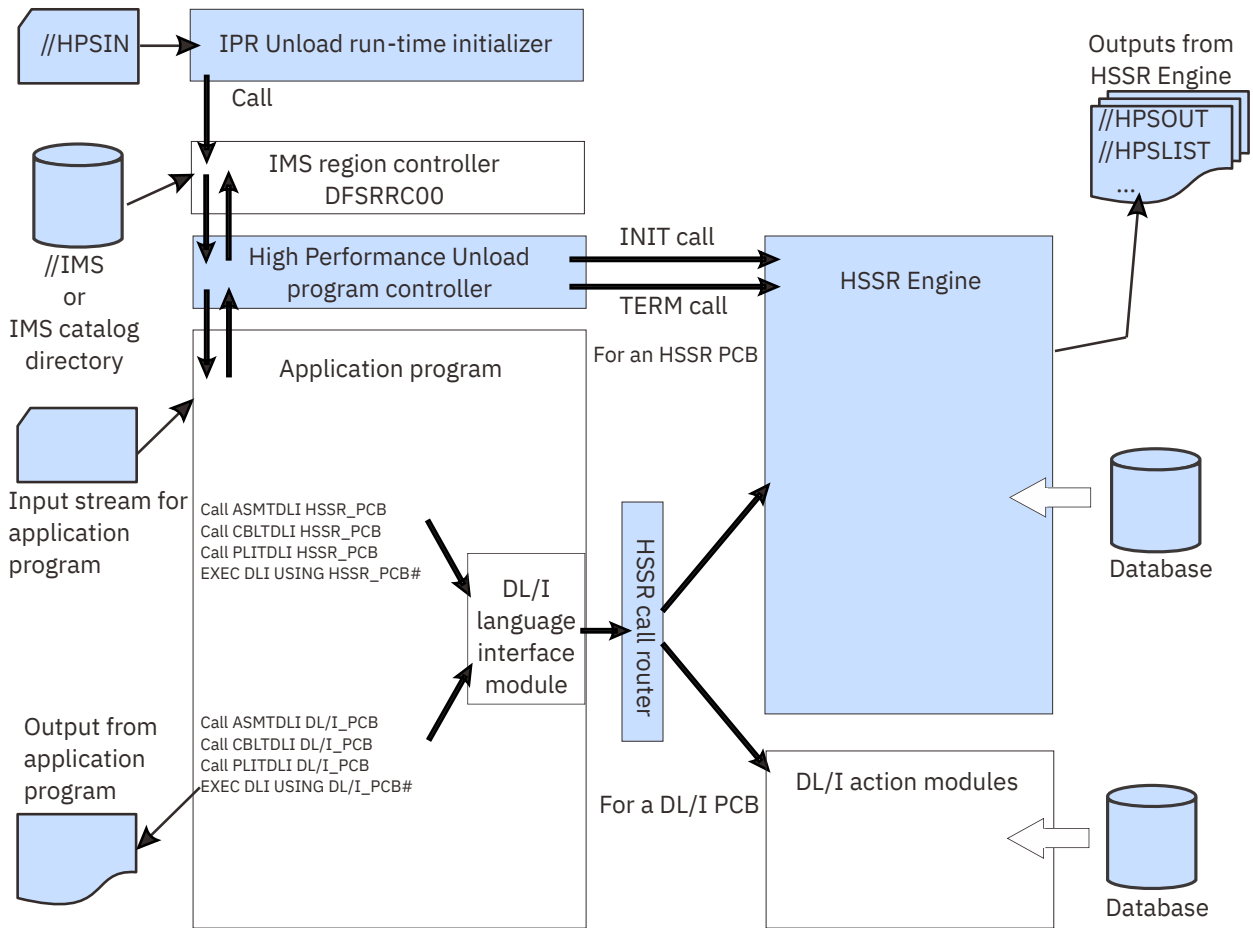

Figure 172. System flow of the API function

## PCB feedback information

The following topics describe the general-use programming interface.

See “Programming interface information” on page 804 to understand the restrictions associated with this type of material.

### Interpreting PCB feedback

An application program must *not* modify any information in the HSSR PCB.

#### GUPI

The access to PCB entries by the application program is restricted to read-only. After a call is made, the PCB feedback in the HSSR PCB contains the same information as a DL/I PCB with some exceptions.

#### GUPI

#### DMTI

**Note:** If `PCBLIST=HSSR`, which is the default, is specified, the PCB list that is passed to the application program is not the same as the PCB list built by IMS. If `PCBLIST=HSSR` is specified, each list entry for a

PCB that is defined as an HSSR PCB points to the corresponding HSSR PCB that has been built by HSSR Engine. An HSSR PCB that is passed to the application program is not the original IMS PCB, but the PCB rebuilt by the program controller of IMS HP Unload. HSSR Engine describes the results of the calls your program issues in the HSSR PCB that is referenced in the call in the same way as in IMS.

DMTI

GUPI

The following figure shows the HSSR PCB mask, which is the same as IMS:

Table 67. HSSR PCB mask

Descriptor	Length	Note
Database Name	8 bytes	
Segment Level Number	2 bytes	
Status Code	2 bytes	See “Status codes” on page 469.
Processing Options	4 bytes	If PCBLIST=HSSR, which is the default, is specified, the first two bytes are always 'GX' and the last two bytes list additional processing options such as 'O ', 'ON', 'OT', or 'E'. If PROCOPT=GONP or GOTP is specified, the last two bytes are 'NP' or 'TP'. If PCBLIST=IMS is specified, the content is same as that for IMS.
Reserved	4 bytes	Do not use this field.
Segment Name	8 bytes	
Length of Key Feedback Area	4 bytes	
Number of Sensitive Segments	4 bytes	
Key Feedback Area	Variable length	

**Note:** For the EXEC DLI command, the DL/I interface block (DIB) is used as the application programming interface. Every part except the status code is the same as the DIB of IMS. The following table shows the format of the DL/I interface block. For details about the status codes, see “Status codes” on page 469.

Table 68. Format of the DIB

Descriptor	Length
Translator Version (DIBVER)	2 bytes
Status Code (DIBSTAT)	2 bytes
Segment name (DIBSEGM)	8 bytes
Segment Level Number (DIBSEGLV)	2 bytes
Key Feedback Length (DIBKFBL)	4 bytes
Database Description Name (DIBDBDNM)	8 bytes
Database Organization (DIBDBORG)	8 bytes

## Status codes

This topic summarizes the status codes of an HSSR call.

The following table shows the status codes returned as the result of an HSSR call:

*Table 69. Status codes of an HSSR call*

<b>Code</b>	<b>Meaning</b>	<b>I/O area</b>	<b>PCB feedback</b>
blank	Normal return. No errors were detected.	Segment data is returned.	PCB has a segment name and a segment level. And the concatenated key is set in the key feedback area.
AI	OPEN error of Data management	Unpredictable.	Unpredictable. You must not use the PCB feedback information.
FM	This status code is returned when: <ul style="list-style-type: none"> <li>• The Randomizing routine returned a return code of 4.</li> <li>• The database is a HALDB, and the key supplied on the call was greater than the high key value for the last partition, or the user partition selection exit routine returned a return code of 4 after having been passed a key value with which to select a partition.</li> </ul>	No segment is returned.	Unpredictable. You must not use the PCB feedback information.
GB	End of database (Issued only for GN and GHN calls or for GN command).	No segment is returned.	The segment name is filled with blanks, and the segment level is set to C'00'; the key feedback area is nullified, and the length of the key feedback area is set to zero. You must not use the PCB feedback information.

Table 69. Status codes of an HSSR call (continued)

Code	Meaning	I/O area	PCB feedback
GE	This status code is returned when a segment that satisfies the segment search argument described in the call could not be found.	No segment is returned.	For a GU or GHU call or for a GU command, the segment name is filled with blanks, and the segment level is set to C'00'; the key feedback area is nullified, and the length of the key feedback area is set to zero. The content of the key feedback area is unpredictable. You must not use the PCB feedback information. For a GN, GHN, GNP, or GHNP call or for a GN or a GNP command, the content of the PCB feedback area is unpredictable. You must not use it.
GG	<p>One of the following errors occurred:</p> <ul style="list-style-type: none"> <li>• Pointer error</li> <li>• key sequence error</li> <li>• partition selection error</li> <li>• other database error</li> </ul> <p>This code can be returned when either PROCOPT=GON or PROCOPT=GOT is specified in the PCB, or when the KEYCHECK=GG option or the SKIPERROR=YES option is specified.</p>	<p>Unpredictable.</p> <p><b>Note:</b> HSSR Engine might skip retrieving some segments while processing the first GN call that follows a GG status code.</p>	<p>Unpredictable.</p> <p>You must not use PCB feedback information.</p>
GP	The program issued a GNP or GHNP call or a GNP command when there was no parentage established, or the segment level specified in the call was not lower than the level of the established parent.	No segment was returned.	Unpredictable. You must not use the PCB feedback information.

Table 69. Status codes of an HSSR call (continued)

Code	Meaning	I/O area	PCB feedback
GX	Key sequence error occurred. This code can be returned only when the KEYCHECK=GX option is specified. For the EXEC DLI command, the status 'GX' is not returned to the application program, but message DFS1041 is issued in the EXEC DLI interface module (DFSEIPBO), and ends with an abend code of U1041.	Segment data is returned.	PCB has a segment name and a segment level and the concatenated key is set in the key feedback area.

**Notes:**

- If there is an error in a call statement or a command statement, the application program receives an abend U4013, instead of status code AC, AD, AJ, or AK.
- If hierarchic levels are changed after a successful GN, GHN, GNP, or GHNP call or a successful GN or a GNP command, a status code of blank is returned, instead of GA.
- If segment types are changed after successful GN, GHN, GNP, or GHNP calls or a successful GN or a GNP command, a status code of blank is returned, instead of GK.
- When a GN call or a GN command is issued after a GU call or a GU command that returned a GE status code, HSSR Engine might not return the same segment that DL/I would return.
- The status code BA is not returned even if an INIT call or an ACCEPT command has been issued with the character string STATUS GROUPE in the I/O area. If a PROCOPT other than GON and GOT is specified for a PCB, and if HSSR Engine encounters unavailable data regarding the database that is referred to by the PCB, HSSR Engine issues an abend.



## Restrictions

Certain restrictions apply to using the API function.

The same restrictions as those for HSSR application programs running on IMS HP Unload apply. For details, see the *IMS High Performance Unload User's Guide* and refer to the topic that explains the application programming interface and the HSSR application programs.

One further restriction in API function of the IPR Unload utility is that Db2 DL/I Batch interface is *not* supported. If you want to run your application program that uses Db2 DL/I Batch interface, write a JCL stream for IMS HP Unload.

## JCL requirements

The following topics describe the JCL requirements for the API function.

### EXEC statement

The JCL stream required to run an HSSR application program is almost the same as that used for Unload function of the IPR Unload utility.

The major difference is that you must code the APPL parameter, instead of the DBD parameter, in the EXEC parameter.

To allow your application program to use the API, you must code the EXEC statement as follows:

```
//stepname EXEC PGM=HPSCMAIN,  
//          PARM='FUNC=UL,APPL=(pgm,psb,rgn)'
```

The PARM= parameter keywords include the followings:

#### **FUNC=UL**

Invokes the IPR Unload utility. This parameter is required.

#### **APPL=(pgm,psb,rgn)**

Specifies that your application program uses the API. This parameter is required for API service.

#### **pgm**

Specifies the application program name.

#### **psb**

Specifies a PSB name.

DLI and DBB regions require this parameter. If the PSB name is the same as the application name, you can omit this parameter.

ULU regions require a DBD name, instead of a PSB name, in this field; a PSB whose name is the same as the DBD is built with full sensitivity to all segments.

#### **rgn**

Specifies one of the following IMS region types: ULU, DLI, or DBB.

If this parameter is omitted, ULU is assumed.

The following figure shows the examples of the APPL parameter.

```
ULU Region  
  APPL=(MYPGM,DBD0001,ULU)  
  APPL=(MYPGM,DBD0001)  
  
DLI Region  
  APPL=(MYPGM,PSB0001,DLI)  
  APPL=(MYPGM,,DLI) (PSB name of 'MYPGM' is assumed.)  
  
DBB Region  
  APPL=(MYPGM,PSB0001,DBB)  
  APPL=(MYPGM,,DBB) (PSB name of 'MYPGM' is assumed.)
```

Figure 173. APPL parameter examples

Optionally, you can specify the DBRC=, SWAP=, IRLM=, IRLMNM=, GSGNAME=, IMSPLEX=, and DFSDF= parameters to specify the job step environment. For details about these parameters, see [Chapter 25, “IPR Unload JCL requirements,”](#) on page 359.

### DD statements

This topic summarizes the DD statements for HSSR application programs.

The following table shows JCL DD statements for HSSR application programs.



Table 70. JCL DD statements for HSSR application programs

DDNAME	Use	Format	Need
STEPLIB	Input		Required
DFSRESLB	Input		Required
IMS	Input		Optional
IMSACB	Input		Optional
<i>database</i>	Input		Required (See <a href="#">Note 1</a> )
DFSVSAMP	Input	LRECL=80, RECFM=FB	Optional
HPSIN	Input	LRECL=80, RECFM=FB	Optional
DFSHALDB	Input	LRECL=80, RECFM=FB	Optional
PROCLIB	Input		Optional
RECONx	Input		Optional
IEFRDER	Output		Optional (See <a href="#">Note 2</a> )
HPSOUT	Output	LRECL=81, RECFM=FB	Required
HPSLIST	Output	LRECL=133, RECFM=FB	Optional
HPSSNAP	Output	LRECL=121	Optional
HPSTRACE	Output	LRECL=133	Optional
SYSUDUMP	Output	LRECL=133	Optional

**Notes:**

1. If you use dynamic allocation, do not use the DD statement for the database data sets.
2. This DD statement is required when the PSB contains a PCB in which the PROCOPT to update the database is specified.

**STEPLIB DD**

Points to the following libraries:

- IMS Database Reorganization Expert load module library (mandatory)
- IMS HP Unload load module library (mandatory)
- IMS RESLIB library (mandatory)
- The load module library that contains the HSSR application program (mandatory)
- The load module library that contains user routines (optional)
- The library that contains DFSMDA members for dynamic allocation of data sets (optional)

The IMS HP Unload load module library must be concatenated before the IMS RESLIB library. This DD statement is required.

**Note:** You do not need to APF-authorize the STEPLIB libraries for the API function of the IPR Unload utility. If, however, the STEPLIB is not authorized (by having unauthorized libraries concatenated, for example), the DFSRESLB DD statement must be specified.

**DFSRESLB DD**

See Chapter 25, “IPR Unload JCL requirements,” on page 359.

**IMS DD**

For ULU regions, this DD statement describes the DBD library. For DLI region, it describes the DBD and the PSB libraries. Those data sets must reside on a direct-access device. This is a required statement

for ULU and DLI regions unless the IMS management of ACBs is enabled. When the IMS management of ACBs is enabled, IMS system ignores the IMS DD statement.

**IMSACB DD**

Describes the ACB library containing the PSB or DBD referred to in the APPL parameter in the EXEC statement. This data set must reside on a direct-access device. This is a required statement for DBB region unless the IMS management of ACBs is enabled. When the IMS management of ACBs is enabled, IMS system ignores the IMSACB DD statement.

**database DDs**

See [Chapter 25, “IPR Unload JCL requirements,” on page 359.](#)

**DFSVSAMP DD**

See [Chapter 25, “IPR Unload JCL requirements,” on page 359.](#)

**HPSIN DD**

This DD statement is optional.

You can specify an HSSR PCB by coding a PCB or a PCBNAME control statement. For details, see [“Control statements for the API function” on page 474.](#)

You can also code control statements for HSSR Engine. For details, see [Chapter 26, “IPR Unload control statements,” on page 367.](#)

For the syntax of control statements, see [“Syntax for the IPR Unload control statements” on page 367.](#)

**DFSHALDB DD**

This DD statement is optional.

You can use the 'HALDB Single Partition Processing' by coding the HALDB control statement. This DD statement is available only in a DL/I and a DBB region. For details, see *IMS System Definition*.

**PROCLIB DD**

See [Chapter 25, “IPR Unload JCL requirements,” on page 359.](#)

**RECON1 DD****RECON2 DD****RECON3 DD**

See [Chapter 25, “IPR Unload JCL requirements,” on page 359.](#)

**IEFRDER DD**

This optional statement defines the IMS log data set.

**HPSOUT DD**

See [Chapter 25, “IPR Unload JCL requirements,” on page 359.](#)

**HPSLIST DD**

See [Chapter 25, “IPR Unload JCL requirements,” on page 359.](#)

**HPSSNAP DD**

See [Chapter 25, “IPR Unload JCL requirements,” on page 359.](#)

**HPSTRACE DD**

See [Chapter 25, “IPR Unload JCL requirements,” on page 359.](#)

**SYSUDUMP DD**

See [Chapter 25, “IPR Unload JCL requirements,” on page 359.](#)

## Control statements for the API function

---

For the API support, you must specify an HSSR PCB.

By default, the first DB PCB in the PSB is considered to be the HSSR PCB. You can code a PCB control statement or a PCBNAME control statement in an HPSIN data set to identify an HSSR PCB other than the default one. You can also code some control statements for HSSR Engine.

## APISET control statement

Specifies a set of HSSR call types that can be used in your HSSR application program.

This control statement is optional. The default is APISET=1.

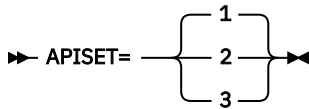

For details about what each APISET supports, see [“Call types supported by each API set” on page 464](#) and [“EXEC DLI command types supported by each API set” on page 465](#).

IBM recommends that you specify APISET=2 or 3 only if your application program issues a call that APISET=1 does not support.

If you specify APISET=3:

- You cannot specify any of the following control statements: BYINDEX, DBSTATS, KEYCHECK, or SKERROR.
- The BLDLPCK control statement is always activated.
- The disposition of the database data sets must be DISP=SHR.

## PCB and PCBNAME control statements

Specify an HSSR PCB within the PSB.

An HSSR PCB must be an HSSR-eligible PCB. For the conditions that an HSSR-eligible PCB must satisfy, see [“Preparing a PSB” on page 462](#).

A PCB for an application program running in a ULU region is defined to be an HSSR PCB by default. You do not need to code a PCB control statement for an API job running in a ULU region.

### Notes:

1. PCB and the PCBNAME control statements are mutually exclusive. If you do not specify the PCB or the PCBNAME statement, the first DB PCB is considered to be selected as the HSSR PCB.
2. You can specify only one PCB as an HSSR PCB by using the PCB or the PCBNAME control statement.

### PCB control statement

The PCB statement allows you to specify an HSSR PCB within the PSB. The PCB must be specified as follows:

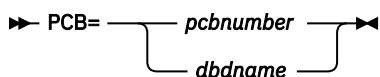

You can specify a PCB by a number (*pcbnumber*) or a DBD name (*dbdname*). When you specify a PCB by a DBD name, HSSR Engine processes the first matching occurrence of the PCB in the PSB as an HSSR PCB.

### PCBNAME control statement

The PCBNAME control statement provides an alternate way of specifying an HSSR PCB. You can specify the HSSR PCB by using the PCB name assigned to it as the statement label or as the operand of the PCBNAME keyword for the PCB statement at PSBGEN.

▶▶ PCBNAME= *pcbname* ▶▶

## PCBLIST control statement

Specifies the type of PCB list that is to be passed to the application program.

This control statement is optional. The default is PCBLIST=HSSR.

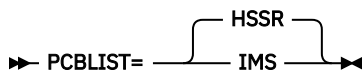

### HSSR

The PCB list that is built by HSSR Engine and that can contain an entry that points to HSSR PCB is passed to the application program.

### IMS

The PCB list that is built by IMS is passed to the application program.

### Notes:

- If your application program issues a DL/I system call that gets access to the IMS PCB list, it is recommended that you specify PCBLIST=IMS. One such call is the INQY call with the FIND subfunction, which returns the PCB address of the requested PCB name.
- If your application program issues an HSSR call as an EXEC DLI command, you must specify PCBLIST=IMS.

## Control statements for HSSR Engine

You can also specify control statements for HSSR Engine.

For details, see [“Control statements for HSSR Engine” on page 389.](#)

## JCL examples for the API function

The following topics provide JCL examples for the API function of the IPR Unload utility.

### Example 1: Running an HSSR application program

The following two JCL examples are for running an application program named MYAPPL. The first example is for running the application in a DL/I region, and the second example is for running the application in a ULU region.

The following example is for running application program MYAPPL in a DL/I region. The application program issues DL/I calls.

```
//IPRUL EXEC PGM=HPSCMAIN,
//      PARM='FUNC=UL,APPL=(MYAPPL,MYPST,DLI),DBRC=Y'
//STEPLIB DD DSN=HPS.SHPSLMD0,DISP=SHR <--Add Tools library
//      DD DSN=IMSVS.SDFSRESL,DISP=SHR
//      DD DSN=USER.PGMLIB,DISP=SHR
//IMSDALIB DD DSN=IMSVS.MDALIB,DISP=SHR
//DFSRESLB DD DSN=IMSVS.SDFSRESL,DISP=SHR
//IMS DD DSN=IMSVS.PSBLIB,DISP=SHR
//      DD DSN=IMSVS.DBDLIB,DISP=SHR
//SYSUDUMP DD SYSOUT=*
//HPSOUT DD SYSOUT=*
//HPSLIST DD SYSOUT=*
//HPSSNAP DD SYSOUT=*
//HPSTRACE DD SYSOUT=*
//HPSIN DD *
PCB=DBHI0010
APISET=3
/*
```

Figure 174. Sample JCL stream to run an HSSR application program in a DL/I region

In this JCL example:

- The second operand of the APPL parameter specifies the name of the PSB (MYPST).
- In the HPSIN DD statement, the PCB statement specifies the DBD name (DBHI0010). PCB=DBHI0010 specifies to use the DBPCB named DBHI0010. The first matching occurrence of DBPCB DBHI0010 in PSB MYPST is processed as an HSSR PCB.

You can specify a DBPCB by a PCB number or a PCB name. See [“PCB and PCBNAME control statements”](#) on page 475.

- In the HPSIN DD statement, APISET=3 specifies to enable all DB/I call types that this API supports. If an unsupported call is issued, any succeeding calls to the HSSR PCB are processed by the native IMS DL/I. Statistics of the calls processed by HSSR Engine are logged in the HPSSLIST data set, and statistics of the calls processed by the native IMS DL/I are logged in the DFSSTAT data set. If you want to tune the performance of IMS DL/I, add a DFSVSAMP DD statement and specify IMS VSAM and OSAM buffers and options in the DD statement.

If you specify APISET=2 instead of APISET=3, application processing ends abnormally if an unsupported call is issued. You can identify which unsupported call was issued by looking at the Trace Output report that is created in the HPSTRACE data set. For more information about supported calls, see [“Call types supported by each API set”](#) on page 464.

The following example is for running application program MYAPPL in a ULU region.

```
//IPRUL EXEC PGM=HPSCMAIN,
//          PARM='FUNC=UL,APPL=(MYAPPL,DBHID001,ULU),DBRC=Y'
//STEPLIB DD DSN=HPS.SHPSLMD0,DISP=SHR <--Add Tools library
//          DD DSN=IMSVS.SDFSRESL,DISP=SHR
//          DD DSN=USER.PGMLIB,DISP=SHR
//IMSDALIB DD DSN=IMSVS.MDALIB,DISP=SHR
//DFSRESLB DD DSN=IMSVS.SDFSRESL,DISP=SHR
//IMS DD DSN=IMSVS.DBDLIB,DISP=SHR
//SYSUDUMP DD SYSOUT=*
//HPSOUT DD SYSOUT=*
//HPSSLIST DD SYSOUT=*
//HPSSNAP DD SYSOUT=*
//HPSTRACE DD SYSOUT=*
//HPSIN DD *
APISET=3
/*
```

Figure 175. Sample JCL stream to run an HSSR application program in a ULU region

In this JCL example:

- The second operand of the APPL parameter specifies the DBD name. In ULU region, you do not need to specify a PCB or PCBNAME control statement.
- A DBPCB that IMS dynamically creates from the specified DBD is always treated as an HSSR PCB.
- The HSSR PCB is created with full sensitivity to all segments and with processing option (PROCOPT) G.

## Example 2: Running an HSSR application program in an IMS-managed ACBs environment

This is an example to run an HSSR application program in an IMS-managed ACBs environment.

If the IMS management of ACBs is enabled, you can access a database without the IMS DD statement.

```
//IPRUL EXEC PGM=HPSCMAIN,
//          PARM='FUNC=UL,APPL=(MYAPPL,MYPSB,DLI),DBRC=Y,DFSDF=CAT'
//STEPLIB DD DSN=HPS.SHPSLMD0,DISP=SHR
//          DD DSN=IMSVS.SDFSRESL,DISP=SHR
//          DD DSN=USER.PGMLIB,DISP=SHR
//IMSDALIB DD DSN=IMSVS.MDALIB,DISP=SHR
//DFSRESLB DD DSN=IMSVS.SDFSRESL,DISP=SHR
//PROCLIB DD DSN=IMSVS.PROCLIB,DISP=SHR
//SYSUDUMP DD SYSOUT=*
//HPSOUT DD SYSOUT=*
//HPSSLIST DD SYSOUT=*
//HPSSNAP DD SYSOUT=*
//HPSTRACE DD SYSOUT=*
//HPSIN DD *
PCB=MYDBD01
APISET=2
/*
```

Figure 176. Sample JCL stream to run an HSSR application program in an IMS-managed ACBs environment

DFSDF=CAT parameter is specified on the EXEC statement. This parameter specifies the DFSDFCAT member that enables IMS-managed ACBs.

The name of the IMS.PROCLIB data set in which the DFSDFCAT member exists is specified on the PROCLIB DD statement.

You must allocate the catalog partition definition data set when unloading a database with DBRC=NO. To do so, add the DFSHDBSC DD statement or the DFSMDA member with the TYPE=CATDBDEF statement.

### Example 3: Running an HSSR application program with the IMS Catalog Definition exit routine

This is an example to run an HSSR application program in an IMS-managed ACBs environment with the IMS Catalog Definition exit routine (DFS3CDX0).

When IMS management of ACBs is enabled, you can unload a database without the IMS DD statement.

```
//IPRUL EXEC PGM=HPSCMAIN,
//          PARM='FUNC=UL,APPL=(MYAPPL,MYPSB,DLI),DBRC=Y'
//STEPLIB DD DSN=HPS.SHPSLMD0,DISP=SHR
//          DD DSN=IMSVS.SDFSRESL,DISP=SHR
//          DD DSN=USER.PGMLIB,DISP=SHR
//IMSDALIB DD DSN=IMSVS.MDALIB,DISP=SHR
//DFSRESLB DD DSN=IMSVS.SDFSRESL,DISP=SHR
//SYSUDUMP DD SYSOUT=*
//HPSOUT DD SYSOUT=*
//HPSLIST DD SYSOUT=*
//HPSSNAP DD SYSOUT=*
//HPSTRACE DD SYSOUT=*
//HPSIN DD *
PCB=MYDBD01
APISET=2
/*
```

Figure 177. Sample JCL stream to run an HSSR application program with the DFS3CDX0 exit routine

The DFS3CDX0 exit routine must be bound to IMSVS.SDFSRESL or a concatenated library.

You must allocate the catalog partition definition data set when unloading a database with DBRC=NO. To do so, add the DFSHDBSC DD statement or the DFSMDA member with the TYPE=CATDBDEF statement.

## Reports and statistics produced by the API function

The API function produces the reports and statistics in the following data sets:

- HPSOUT data set
- HPSLIST data set

The following reports are written in the HPSOUT data set:

- HPSIN Control Statements report
- Buffering and I/O Statistics report

These reports are the same as those produced by the Unload function. For details, see [Chapter 28, “IPR Unload reports,”](#) on page 409.

If the DBSTATS=YES option is specified in HPSIN, the following reports are also written in the HPSOUT data set:

- DB Statistics report (for HDAM, HIDAM, PHDAM, PHIDAM, and HISAM databases)
- Randomizing Statistics report (for HDAM and PHDAM databases)

The contents of these statistics reports are the same as those produced for IMS HP Unload. For details of these statistics reports and how to use these statistics for database tuning, see the *IMS High Performance Unload User's Guide* and read the topic that explains how to tune a database with the database tuning statistics.

The HPSLIST data set contains the report and statistics produced by HSSR Engine. The following reports are written in the data set:

- HALDB Partition Definition report (only for a HALDB)
- HALDB Partitions Accessed report (only for a HALDB)
- DB Call Statistics report
- CAB Statistics report

**Note:** CAB (Chained Anticipatory Buffering) is the name of the buffering method provided by the buffer handler of HSSR Engine.

The reports and statistics produced in the HPSLIST data set are intended to be used for tuning HSSR Engine or for problem determination. These reports are the same as those written in the HSSRSTAT data set of IMS HP Unload. For details of the reports, see the *IMS High Performance Unload User's Guide* and read the topic that explains about reports and output from HSSR Engine.

For the purpose of problem determination, the following data sets are also provided:

- HPSTRACE data set
- HPSSNAP data set

The HPSTRACE data set contains the trace information and diagnostics information for GG status codes. The following trace reports are produced in the data set:

- HSSR Trace Output report
- HSSR Trace Output report with diagnostics

These trace reports are the same as those written in the HSSRTRAC data set of IMS HP Unload. For details of the reports, see the *IMS High Performance Unload User's Guide* and read the topic that explains about reports and output from HSSR Engine.

If any abnormality is detected during the initialization of HSSR Engine, a snapshot of HSSR Engine control blocks is dumped into HPSSNAP data set. The data might be needed by IBM to analyze a problem. The content of the data set is the same as that of the HSSRSNAP data set of IMS HP Unload. For details, see the *IMS High Performance Unload User's Guide* and read the topic that explains about reports and output from HSSR Engine.

For other output data sets, see [Chapter 25, “IPR Unload JCL requirements,” on page 359](#).

## Compatibility considerations

---

Certain compatibility considerations apply.

The IPR Unload utility can run application programs written for DBT HSSR<sup>4</sup>, if the application program:

- Does not issue any REPL call
- Uses only one HSSR PCB

If a PCB other than the default needs to be processed as an HSSR PCB, you must code a PCB or PCBNAME control statement in HPSIN.

If you need full compatibility with DBT HSSR, it is recommended that you run the application program by using IMS HP Unload. For more information, see the *IMS High Performance Unload User's Guide*.

---

<sup>4</sup> IMS System Utilities/Data Base Tools Version 2, High Speed Sequential Retrieval (5685-093).





---

## Chapter 31. Tips for unloading damaged databases

The following topics discuss the problems you might encounter with damaged databases, and the options available for repairing them.

### Topics:

- [“Using SKIPERROR to unload damaged databases” on page 481](#)
- [“Rules for unloading with the SKIPERROR option” on page 481](#)

---

### Using SKIPERROR to unload damaged databases

If a database contains incorrect physical HD pointers or incorrect HISAM records that you cannot correct by standard IMS recovery procedures, such as database backout or database recovery, you can correct the error by using IBM IMS Database Repair Facility.

The procedure requires a database specialist who understands how to repair the database by using ZAPs.

As an alternative, the IPR Unload utility offers the SKIPERROR option, which enables unloading of HIDAM, HDAM, PHIDAM, PHDAM, or HISAM databases even if they contain incorrect physical pointers or incorrect HISAM records. SKIPERROR skips the processing of incorrect pointers or records, which results in some segment occurrences being lost on the unloaded database data set. You can then use the unloaded database as input to the IPR Reload utility or the standard IMS HD Reorganization Reload utility to reconstruct a new database. Unless the damaged database involves logical relationships, your new database becomes error-free from the technical IMS standpoint.

If a database contains logical relationships, prefix resolution might fail on a subsequent reload because a logical parent segment has been bypassed. You can correct this by locating the logical child records that refer to the logical parent and eliminating them from the unloaded data set. The relationships can then be reestablished with maintenance programs after the reload.

**Note:** The IPR Unload utility cannot process segments with segment codes in error.

---

### Rules for unloading with the SKIPERROR option

This topic summarizes certain rules for unloading with the SKIPERROR option.

Follow these rules when you unload a damaged database:

- You must specify the DIAGG option on a control statement in the HPSIN data set. The DIAGG option provides the following diagnosis information in addition to technical information for the highly skilled database specialists in the HPSTRACE data set:
  - Information about the last segment that was successfully unloaded before encountering the database error:
    - The segment name
    - The concatenated PCB key feedback area
  - Information about the first segment that was successfully unloaded after the database error:
    - The segment name
    - The concatenated PCB key feedback area
    - The segment data
  - The name of the segment types for which some segment occurrences might be missing on the unloaded data set.

You can find the information previously listed in the HSSR Trace Output report with diagnostics, and the information can be used to locate the error and to see which segment types might be missing from a segment. Using this information, you can then determine which lost database segments must be

inserted after a successful reload into the database. For the detailed description of HSSR Trace Output report with diagnostics, see the *IMS High Performance Unload User's Guide*.

For each incorrect pointer, the DIAGG option might write more than 4000 print lines on the HPSTRACE data set. To avoid system abends S722 or SB37, allocate the HPSTRACE data set on a tape or allow the job to produce a large number of printed lines—for example, with an OUTLIM JCL parameter.

- If you use the SKIPERROR option, you must also consider activating the KEYCHECK=GG option. The IPR Unload utility then performs more error checking while unloading a damaged database. However, do not use the KEYCHECK=GG option if you are going to reload the unloaded database and if you do not want to lose any segments in the original database.

**Note:** If the SKIPERROR option is used without the KEYCHECK=GG option, the unloaded database might contain segments that are not in key sequence.

- Before using the new database created through the unload and reload processes, determine how many segments were skipped or lost during the unloading process as follows:
  1. Reloading the database without destroying the original damaged database.
  2. Running HD Pointer Checker utility of IBM IMS HP Pointer Checker against the original damaged database.
  3. Comparing the number of occurrences of each segment type in the original damaged database (shown by the HD Pointer Checker utility) to the segment count summary (provided by the IPR Unload utility in HPSOUT).

By combining information about the number of skipped or lost segments with the DIAGG key feedback information, you can decide whether the new database is acceptable. Make sure that you run the HD Pointer Checker utility against the new database to confirm that the new database is free of IMS technical errors.

- After a "crash," the damaged databases should be recovered with standard IMS recovery procedures such as emergency restart, database backout, and the database recovery utility. Run the IPR Unload utility with the SKIPERROR option only after these recovery procedures have been completed.

The SKIPERROR option does not cope with DASD I/O errors. Use of this option requires a prior recovery from DASD I/O errors through standard recovery procedures.

The following rules apply to non-partitioned databases involved in logical relationships:

- Unloading and reloading of huge databases that are heavily involved in logical relationships might require many hours for their scanning, unloading, reloading, prefix resolution, prefix update, and image copy. For such databases, consider using IBM IMS Database Repair Facility as an alternative to the unload and reload approach.
- If you suspect that logical pointers—that is, logical parent pointers, logical child pointers, logical twin pointers, or counter fields—are incorrect, run the IMS Database Preorganization utility using the DBIL control statement. Unload and reload all related databases. Refer to the description of the HD Reorganization Unload utility DFSURGU0 in *IMS/ESA Utilities Reference: Database*.

When you unload a damaged non-partitioned database with a logical pointer error in a logical child segment with the virtual LPCK defined, you must specify BLDLPCK=YES in the HPSIN data set.

- Assume that the damaged database is involved in logical relationships and one of the following types of segment occurrences is skipped or lost during the unload:
  - A logical parent segment that has one or more logical children
  - A logical child segment that is physically paired

The subsequent processing of the database (that is, reloading, prefix resolution, and prefix update) does not complete successfully unless a user program post-processes the output of the unload job.

For such cases, use the IBM IMS Database Repair Facility before running the IPR Unload utility.

---

## Part 6. Reloading a database

The following topics explain how to reload a database by using the IPR Reload utility.

**Topics:**

- [Chapter 32, “IPR Reload utility,” on page 485](#)
- [Chapter 33, “Reorganizing a HALDB,” on page 489](#)
- [Chapter 34, “IPR Reload JCL requirements,” on page 491](#)
- [Chapter 35, “IPR Reload control statements,” on page 501](#)
- [Chapter 36, “IPR Reload JCL examples,” on page 537](#)
- [Chapter 37, “IPR Reload reports,” on page 541](#)
- [Chapter 38, “User exits for IPR Reload,” on page 579](#)



---

## Chapter 32. IPR Reload utility

The following topics describe the IPR Reload utility.

### Topics:

- [“IPR Reload overview” on page 485](#)
- [“IPR Reload features” on page 485](#)
- [“Data flow for IPR Reload” on page 486](#)
- [“IPR Reload compatibility with other utilities” on page 487](#)
- [“IPR Reload restrictions” on page 488](#)

---

### IPR Reload overview

The IPR Reload utility is a functional replacement of IMS HD Reorganization Reload utility. It reloads IMS HISAM, SHISAM, HDAM, HIDAM, PHDAM, and PHIDAM databases by using high-performance methods. It also analyzes database performance and prepares reports containing valuable space usage statistics and segment pointer statistics.

---

### IPR Reload features

This topic introduces the features of the IPR Reload utility.

#### Reload IMS databases by using high-performance methods

The IPR Reload utility performs high-performance reloading of IMS databases from an HD unloaded data set created by:

- The IPR Unload utility
- IBM IMS HP Unload for z/OS
- The IMS HD Reorganization Unload utility (DFSURGU0)

Optionally, the IPR Reload utility reloads an HD unloaded data set with the compressed segments, created by the IMS HP Unload utility or the IPR Unload utility, in a compressed form without calling the segment compression routine.

For more information about the compressed segments, see [“COMPRESS control statement” on page 513](#).

You can use this utility to increase efficiency of the database reorganization process. The supported database organizations are:

- HDAM (Hierarchical Direct Access Method)
- HIDAM (Hierarchical Indexed Direct Access Method)
- PHDAM (Partitioned Hierarchical Direct Access Method)
- PHIDAM (Partitioned Hierarchical Indexed Direct Access Method)
- HISAM (Hierarchical Indexed Sequential Access Method)
- SHISAM (Simple Hierarchical Indexed Sequential Access Method)

The IPR Reload utility supports logical relationships and secondary indexes. This is also true for HALDBs.

The IPR Reload utility supports the IMS DBRC feature.

**Note:** The IPR Reload utility enables you to reload HISAM and SHISAM databases from an HD unloaded data set created by the IPR Unload utility or the IBM IMS HP Unload for z/OS.

## Initialize an empty database

If you specify the DFSUINPT DD DUMMY statement, the IPR Reload utility initializes a database that is one of the following types: HDAM, HIDAM, HISAM, or SHISAM.

Initializing an empty HALDB database is the performance replacement of the IMS HALDB partition data set initialization utility (DFSUPNTO). It initializes PHDAM and PHIDAM database partitions for the DBRC RECON record whose PARTITION INIT NEEDED flag is on.

For an HDAM database and each partition of a PHDAM database, the entire root addressable area is preformatted.

## Dynamic allocation of database data sets

The IPR Reload utility provides ease of use by the dynamic allocation of the database data set. To specify libraries that contain the DFSMDA members for dynamic allocation, DD statement IMSDALIB is supported. The DD statement bypasses the step that needs APF authorization of the dynamic allocation library. DBRC is supported.

## Provide a user exit facility for additional processing of each segment

The IPR Reload utility supports a user exit routine. The IPR Reload utility invokes the user exit routine to exercise additional selectivity or modification of segments to be received from the HD unloaded data set.

## Generate statistics reports to aid in tuning the database

The IPR Reload utility generates statistics reports on a database, its data sets, its segments, its segment pointers, its database record lengths, and information about randomizing, which will be your valuable database tuning aids. For details, see [“HPSOUT data set” on page 541](#).

## Support partitioned databases

The IPR Reload utility supports reloading of PHDAM or PHIDAM databases introduced by High Availability Large Database (HALDB) of IMS 7 or later. You can reload either an entire database or only a single partition of a HALDB.

## Store the reports in the Output repository of IMS Tools KB

The IPR Reload utility can store the reports in the Output repository of IMS Tools KB by using the ITKBSRVR=*servername* control statement. To use this feature, you need to set up the environment. For details, see [“Task 2: Completing configuration for IMS Tools Knowledge Base” on page 44](#).

## Data flow for IPR Reload

---

This topic describes the data and the process flow for the IPR Reload utility.

The following figure shows the general data flow for the IPR Reload utility.

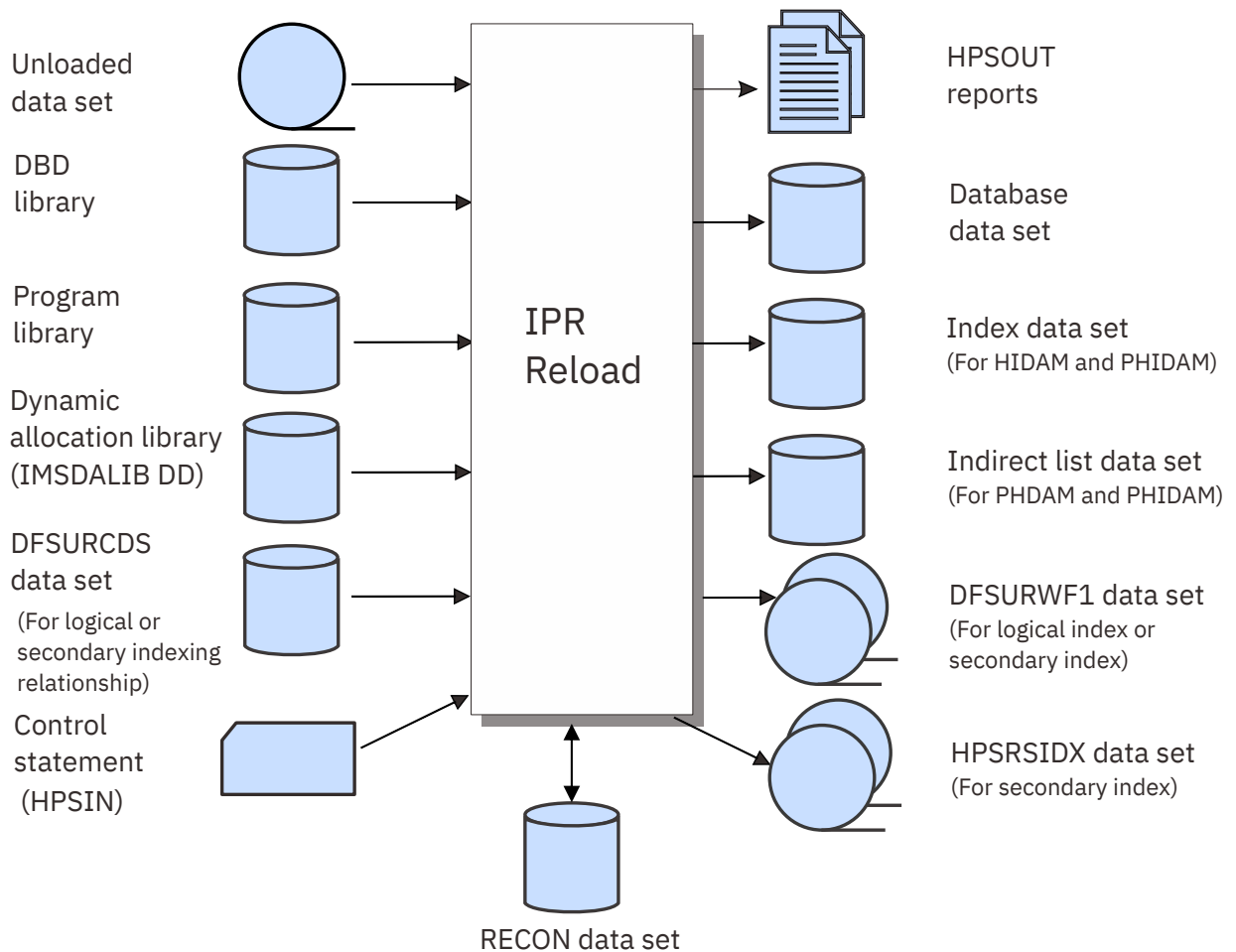

Figure 178. Data flow of the IPR Reload utility

## IPR Reload compatibility with other utilities

The IPR Reload utility is compatible with other utilities.

The IPR Reload utility receives an HD unloaded data set created by the following utilities:

- The IPR Unload utility
- IBM IMS High Performance Unload for z/OS
- IMS HD Reorganization Unload utility

The IPR Reload utility also receives a compressed format of the HD unloaded data set created by the following utilities:

- The IPR Unload utility
- IBM IMS High Performance Unload for z/OS

*Work file 1* data sets (DFSURWF1) are compatible with the those created by the IMS HD Reorganization Reload utility. It can be received by the following utilities:

- IBM IMS Index Builder for z/OS
- IBM IMS High Performance Prefix Resolution for z/OS
- IMS Prefix Resolution utility

## IPR Reload restrictions

---

The IPR Reload utility has certain restrictions.

The IPR Reload utility performs the same functions as the IMS HD Reorganization Reload utility with the following restrictions:

- HDAM DBDs must specify a nonzero maximum relative block number in the RMNAME operand of the DBD macro because it formats the entire root addressable area.
- The IPR Reload utility does not run under the Utility Control Facility (UCF). Checkpoint and restart of the reload process under the UCF is not supported.
- The difference in the free space search algorithms between IMS HD Reorganization Reload utility and the IPR Reload utility might result in an increase in DASD usage.
- The IPR Reload utility does not provide an application programming interface. If you want to use application programming interface, see the *IMS High Performance Load User's Guide*.



---

## Chapter 33. Reorganizing a HALDB

To reorganize a HALDB, you must run several programs.

Reorganizing a HALDB, however, is simpler than reorganizing a non-HALDB because neither complicated job steps for logical relationships nor secondary indexes are required for a HALDB.

### Topics:

- [“Job steps” on page 489](#)
- [“Reorganizing partitions individually” on page 490](#)

---

## Job steps

This topic discusses the steps required for reorganizing a HALDB.

### Procedure

A typical job stream for reorganizing a HALDB contains some or all of the following steps:

1. Back up the partitions you are reorganizing.

The IMS Database Image Copy utility (DFSUDMPO) or IMS HP Image Copy creates a copy of each data set group of the old partitions. This is the backup copy of your database. It can be used when something goes wrong during the reorganization process.

This step is not mandatory, however, it is recommended that you always include this step in your reorganization job.

2. Unload your partitions.

The IPR Unload utility or IMS HD Reorganization Unload utility (DFSURGU0) creates a sequential data set containing the old unloaded partitions. You can choose to unload a single partition, a sequence of partitions, or all the partitions in your database.

3. Do DBDGEN.

This IMS procedure creates the DBDs for the reorganized database. This step is optional. If you want to change the parameters in your DBD that affect all partitions, you must reorganize all the partitions in your database.

4. Change partition definitions.

IMS HALDB Partition Definition utility (DFSHALDB) changes the HALDB partition definitions stored in the DBRC RECON data sets. This step is optional.

5. Delete then Define the partition data sets.

IDCAMS deletes and allocates the partition data sets. This step is optional. For VSAM, you must use the REUSE parameter in your original CLUSTER definition to make this step optional. To switch to the VSAM load mode to improve the performance of the ILDS rebuilding process, specify the REUSE parameter in your ILDS CLUSTER definition, and specify ILDSBLD=YES.

6. Mark partitions as needing initialization.

The DBRC CHANGE.DB command marks a partition as needing initialization. This step is optional. If you are sure that every partition you are reorganizing will be populated by segments after reload, you can skip this step. If not, mark all partitions you are reorganizing as needing initialization.

7. Sort the unloaded database records in partition order.

If you change the partition boundaries during the reorganization, this step is mandatory. Physical Sequence Sort for Reload of IMS HP Load for z/OS sorts the unloaded database records so that the partitions are in the order that is required for the subsequent reload.

8. Run the IPR Reload utility.

If you mark the partitions as needing initialization, specify PARTINIT=YES in your IPR Reload utility job.

9. Back up the partitions you reorganized.

This step creates the first backup copy of the new partitions.

## Reorganizing partitions individually

---

If you choose to reorganize the partitions individually, you can achieve a degree of parallelism in your reorganization process, because all the partition reorganization jobs can run simultaneously.

### About this task

You should be able to reduce the overall reorganization time by running your jobs simultaneously.

In this case, however, you cannot use the partition initialization function during the reload processing that is done by the IPR Reload utility because other partitions might be being reorganized simultaneously. You need to initialize the partition before the reload processing.

When you reorganize the partitions individually, the recommended reloading process is as follows:

### Procedure

1. Run the IPR Reload utility job by specifying DFSUINPT DD as DUMMY and specifying PARTINIT=YES. This way, you can use the IPR Reload utility in place of using the IMS HALDB Partition Initialization utility (DFSUPNTO) or IMS Database Prereorganization utility (DFSURPRO).
2. Reload each partition individually by specifying PARTINIT=NO in each IPR Reload utility job.

## Chapter 34. IPR Reload JCL requirements

To use the IPR Reload utility, supply an EXEC statement with PARM parameters, and appropriate DD statements.

The following table summarizes the DD statements. Actual JCL requirements follow the table.

*Table 71. DD statements and record format for the IPR Reload utility*

<b>DDNAME</b>	<b>Use</b>	<b>Format</b>	<b>Need</b>
STEPLIB	Input		Required (See <a href="#">Note 1</a> )
IMS	Input		Optional
PROCLIB	Input		Optional
DFSACBPD	Input	LRECL=80	Optional
SYSIN	Input	LRECL=80	Optional
DFSUINPT	Input	(See <a href="#">Note 2</a> )	Required
DFSURCDS	Input	LRECL=1600	Optional
DFSVSAMP	Input	LRECL=80	Optional
HPSIN	Input	LRECL=80	Optional
DDEFPPDS	Input	RECFM=FB LRECL=80	Optional
RECON <sub>x</sub>	Input/Output		Optional (See <a href="#">Note 3</a> )
<i>database</i>	Output	(See <a href="#">Note 2</a> )	Optional (See <a href="#">Note 3</a> )
DFSURWF1	Output	RECFM=VB LRECL=900	Optional
HPSRP <sub>nnn</sub>	Output	RECFM=FB LRECL=7250	Optional (See <a href="#">Note 4</a> )
HPSRSIDX	Output	RECFM=VB LRECL=900	Optional
OVERFLOW	Input/Output	RECFM=VB (See <a href="#">Note 2</a> )	Optional
SORTWK <sub>nn</sub>	Input/Output		Optional
HPSRISMG	Output	LRECL=133	Optional
HPSRILEA	Input/Output		Optional
HPSRILEB	Input/Output		Optional
HPSRWK <sub>nn</sub>	Input/Output		Optional
IMSDALIB	Input	Same as that used in the IMS control region startup JCL stream.	Optional (See <a href="#">Note 5</a> )
SEQERROR	Output	RECFM=VB	Optional (See <a href="#">Note 6</a> )
HPSOUT	Output	LRECL=81	Required
HPSRAMSO	Output	LRECL=133	Optional

Table 71. DD statements and record format for the IPR Reload utility (continued)

DDNAME	Use	Format	Need
HPSSNAP	Output	LRECL=133	Optional
SYSUDUMP	Output	LRECL=133	Optional

**Notes:**

1. The load module library of STEPLIB must be APF-authorized except for the case HPIO=NO is specified. If HPIO=NO is specified and a library concatenated to STEPLIB is not APF-authorized, the DFSRESLB DD statement is required. DFSRESLB DD points to an authorized library that contains IMS SVC modules.
2. The large format data set can be specified when z/OS 1.7 or later is used.
3. If you use dynamic allocation, do not use the DD statements for these data sets.
4. HPSRP $nnn$  DD statement is effective when the WFPHLQ control statement is specified for the IPR Reload utility.
5. The IMSDALIB DD statement makes it possible to specify an MDA member in a library that is not registered to APF. It bypasses the need of APF authorization of the dynamic allocation library.
6. This data set is required only if the SEQERROR=SAVE control statement is specified.

**EXEC**

Must be in this form:

```
//name EXEC PGM=HPSCMAIN,
//          PARM='FUNC=RL,DBD=dbdname'
```

Specify HPSCMAIN as the program name. The PARM= parameter keywords are as follows:

**FUNC=RL**

Invokes the IPR Reload utility function to reload the database. This parameter is required.

**DBD=*dbdname***

*dbdname* is the name of the DBD that includes the database to be reloaded. This parameter is required.

Optionally, you can specify the following keywords to specify the job step environment:

**DBRC=**

Specifies whether the IPR Reload utility uses DBRC.

**Y**

DBRC is used.

**N**

DBRC is not used unless the DBRC=FORCE option is specified during IMS system generation.

If this parameter is not specified, the default setting determined by IMS system generation is used.

To reload a HALDB, specify DBRC=Y.

**IMSPLEX=*name***

Specifies the IMSplex name that is to be used by IMS DBRC SCI Registration. This parameter is 1- to 5-characters.

**DBRCGRP=*ccc***

Specifies the DBRC group identifier that is to be used by IMS DBRC SCI Registration. This parameter is 3 characters.

**SWAP=**

Makes the address space swappable or non-swappable.

**Y**

The address space is made swappable.

**N**

The address space is made non-swappable.

The default is N.

**IRLM=**

Specifies whether the IPR Reload utility uses IRLM.

**Y**

IRLM is used.

**N**

IRLM is not used.

If this parameter is not specified, the default setting determined by IMS system generation is used.

**IRLMNM= *irlm***

Specifies the IRLM subsystem name (a 1-to-4-character alphanumeric name), if IRLM=Y is specified.

**GSGNAME= *gsgname***

Specifies the name of the global service group (GSG).

This parameter is optional.

**DFSDF= *ccc***

Specifies the 3-character suffix of the DFSDFxxx member of the IMS.PROCLIB data set. You must also specify the PROCLIB DD statement.

**STEPLIB DD**

Points to the following libraries:

- IMS Database Reorganization Expert load module library (mandatory)
- IMS HP Load load module library (mandatory)
- IMS Library Integrity Utilities load module library (either one is required when DECODEDBD=YES)
- IMS RESLIB library (mandatory)
- The load module library that contains user routines (optional)
- The library that contains DFSMDA members for dynamic allocation of data sets (optional)
- The SGLXLOAD library of IMS Tools Base (optional)

To reload a database in an IMS-managed ACBs environment or offload eligible workloads to zIIP processors, you must add the SGLXLOAD library of IMS Tools Base to the STEPLIB DD concatenation.

- IMS Catalog Definition exit routine (DFS3CDX0) library (optional)

To reload a database in an IMS-managed ACBs environment without specifying the DFSDF= parameter keyword to the EXEC statement or reload an IMS catalog database that is not registered in the RECON data sets, you must add the IMS Catalog Definition exit routine library to the STEPLIB DD concatenation.

This DD statement is required.

**IMSDALIB DD**

Specifies a partitioned data set or data sets that contains the dynamic allocation members for the database, index and RECON data sets. Allocation of the database, index and the RECON data sets will be attempted in the following order:

1. The DD statements coded in the JCL stream
2. Dynamic allocation members in the IMSDALIB concatenation
3. Dynamic allocation members in JOBLIB or STEPLIB concatenation

For dynamic allocation of HALDB databases, the RECON data sets (and not this DD statement) are used instead of this DD statement.

#### **IMS DD**

Describes the library containing the DBD referred to in the PARM field of the EXEC statement. This data set must reside on a direct-access device.

This DD statement is required unless the IMS management of ACBs is enabled. When the IMS management of ACBs is enabled, IMS system ignores the IMS DD statement.

#### **PROCLIB DD**

Points to the IMS.PROCLIB data set. If DFSDF=ccc is specified on the EXEC statement, you must specify this DD statement and ensure that the DFSDFccc member exists in the IMS.PROCLIB data set.

#### **DFSACBPD DD**

Defines the control statement data set to be used in an IMS-managed ACBs environment. This DD statement is optional. STAGING is the only valid keyword.

When the IMS management of ACBs is enabled, IMS retrieves the DBDs from the IMS catalog. If you unload a database and make offline changes to the database definition, you can reload either the active changes from the IMS catalog directory data sets or the pending changes from the catalog staging data sets.

When the IMS management of ACBs is enabled, by default, IPR Reload utility obtains the active database definition from the IMS catalog directory. To override the default behavior and obtain the pending ACBs from the staging data sets in IMS catalog, specify the keyword STAGING on the DFSACBPD DD statement.

When the IMS management of ACBs is not enabled, the DFSACBPD DD statement is ignored.

#### **SYSIN DD**

Specifies the STAGING keyword to obtain the pending ACBs from the IMS catalog staging data set before they are activated. The STAGING keyword can either be specified with this DD statement or with the DFSACBPD DD statement.

#### **DFSUINPT DD**

Describes the input data set containing the data to be reloaded. This is the data set created by the IPR Unload utility or other equivalent utility. The data set must reside on either a tape or a direct-access device.

#### **DFSURCDS DD**

Defines the control data set for this program. The data set must be the output generated by the IMS Database Preorganization utility (DFSURPRO). This DD statement must be included if logical relationships exist.

This data set must reside on either a tape or a direct-access device.

#### **DFSVSAMP DD**

Describes the data set that contains the buffer pool information that is required by the IMS DL/I buffer handler. This data set is required. For more information about control statement format, see *IMS System Definition*.

##### **Notes:**

1. When the DFSVSAMP DD card is omitted, DL/I Buffer Pool is not allocated.
2. DFSVSAMP DD is optional unless you are reloading HALDB or are using the DL/I call in the user exit routine.
3. You must specify DFSVSAMP DD when reloading HALDB or when using the DL/I call in the user exit routine.

#### **HPSIN DD**

Defines an optional data set that contains control statements specifying the optional functions of the IPR Reload utility.

## DDEFPDS DD

Defines the optional data set that contains the IDCAMS commands for deleting and defining the database data sets to be processed by the IPR Reload utility. The IPR Reload utility searches for the delete and define statements for each database data set in the member that has the same name as the *database* DD name.

The member must contain only the delete and define statements.

### Requirements:

- To delete and define database data sets by specifying this DD statement, the load module library of STEPLIB must be authorized through the Authorized Program Facility (APF).
- To delete and define HALDB data sets by specifying this DD statement, the input unloaded data set must be created by the IPR Unload utility with the CHECKREC=YES option. The unloaded data set must not be concatenated.

## RECONx DD

This statement provides RECON1, RECON2, and RECON3 DD statements under the same conditions as for standard IMS jobs. If RECON data sets are allocated dynamically, do not specify these DD statements.

IBM recommends that you use the IPR Reload utility to allocate these data sets dynamically.

## database DD

Defines the database data set to be reorganized. You need one statement for each data set that appears in the DBD that describes this database. The ddname must match the ddname in the DBD.

For a HIDAM database, DD statements must also exist for the data sets that represent the index. The DD statements that relate to the index must contain ddnames specified in the DBD for the index database. No DD statements are required for whatever secondary indexes that might be associated with this database.

For a HISAM database, DD statements must exist for both the primary data set (KSDS) and the overflow (ESDS) data sets. The DD name for primary and the overflow data sets must be the same as the ddname in the DBD that was referenced when this data set was unloaded.

This data set must reside on a direct-access device.

For VSAM database data sets, the SPEED option for DEFINE CLUSTER is strongly recommended. The SPEED option improves performance of the IPR Reload utility.

The IPR Reload utility optimizes the buffer specification for the database data set by itself. You do not need to specify the AMP= parameter or the DCB=(NCP=) parameter for the DD statement.

**Note:** If you use dynamic allocation, do not use the DD statement for the database data sets.

For HALDBs, no DD statements are necessary for any database data set because the data sets are always dynamically allocated.

## DFSURWF1 DD

Describes the work data set to be created during reload. The data set is used as input to the following utilities to resolve logical or secondary index relationships:

- IMS Index Builder
- IBM IMS HP Prefix Resolution
- IMS Database Prefix Resolution utility

This DD statement is required if at least one of the following conditions are met:

- The database is HDAM, HIDAM, or HISAM and it has logical relationship.
- The database has a secondary index and INDEXBLD=NO is specified, but the HPSRSIDX DD statement is not coded.

In these cases, if WF1REC=NO is specified, you can omit the DD statement. In other cases, the DD statement is not required.

**Notes:**

1. If WF1REC=NO is specified, you can omit this DD statement. If the preceding condition is not met, this DD statement is not required.
2. If you omit the DFSURWF1 DD statement and specify the WF1DSN statement, IPR Reload allocates the DFSURWF1 data set dynamically. You can specify the attributes of the data set by using the WF1SPACE, WF1UNIT, and WF1VOL statements.

You can specify DUMMY if the database being reloaded is neither involved in a logical relationship nor with a secondary index.

If the HPSRSIDX DD statement is specified, this data set contains all updated data for segments involved in logical relationships, which is used as input to utilities to resolve logical relationships.

The DCB parameters for the DD statement must include RECFM=VB and BLKSIZE. The specification must be the same as that for the work data set of the user's initial load program or for the Database Scan utility (DFSURGSO). A value of LRECL=900 is recommended, but a smaller value (as small as 300) can be used if no secondary indexes are present or if HPSRSIDX DD statement is specified.

The data set must reside on either a tape or a direct-access device.

**HPSRP $nnn$  DD**

Describes the WFP work data sets. WFP data sets are work data sets that can be used by Index Builder to rebuild partitioned secondary indexes (PSINDEXes). These data sets are created while the IPR Reload utility reloads HALDB partitions. One work data set is created for each HALDB partition.

If you want the IPR Reload utility to dynamically allocate WFP data sets, omit this DD statement.

For  $nnn$ , specify a 3-digit decimal number in the range of 001 - 999. The value can also be T00 or T01. T01 represents 1000, and T01 represents 1001. If you designate the IPR Reload utility to dynamically allocate the WFP data sets, the IPR Reload utility uses sequence numbers for  $nnn$ .

The data sets must reside on a direct-access device.

Create WFP data sets when all of the following conditions are met:

- The database has PSINDEXes.
- You want to rebuild the PSINDEXes by using IMS Index Builder in a subsequent job step or in another job.
- You want to avoid scanning the database while rebuilding indexes with IMS Index Builder.

If you are not sure whether the HALDB database contains empty partitions, use the unloaded data set that is created by the IPR Unload utility with the CHECKREC=YES option. Otherwise, WFP data sets are not created for the empty partitions.

**Naming convention for WFP data sets**

If you specify the names of WFP data sets by using HPSRP $nnn$  DD statements, ensure that the data set names on the DSN parameters conform to the following naming convention.

The prefix for the WFP data sets is specified by the WFPHLQ control statement. For each HPSRP $nnn$  DD statement specified, specify the data set name as follows:

```
DSN=WFPHLQ_value.partition_name.WFP
```

For example, if you specify WFPHLQ=IMSTOOLS.WORK.HMPORDP1 to define the prefix, and if you specify HPSRP001 and HPSRP002 DD statements for partitions that are named PART001 and PART002, the DSN parameters for the WFP data sets must be specified as follows:

```
DSN=IMSTOOLS.WORK.HMPORDB1.PART001.WFP
DSN=IMSTOOLS.WORK.HMPORDB1.PART002.WFP
```

If you do not specify the HPSRP $nnn$  DD statement, the IPR Reload utility allocates the data sets dynamically by using the values summarized in the following table.



Table 72. Dynamic allocation parameters used for WFP data sets

Parameter	Value	Description
DDN	HPSRP $nnn$	$nnn$ : Sequence number
DSN	$hlq.partition\_name.WFP$	$hlq$ : The value that is specified on the WFPHLQ control statement  $partition\_name$ : The partition name of the primary database  WFP: Fixed value
DISP	NEW,CATLG,DELETE	
UNIT	$unit\_name$	The value that is specified on the WFPUNIT control statement. If the control statement is not specified, SYSALLDA is used.
SPACE	{(TRK, or CYL), $primary\_alloc$ , $secondary\_alloc$ ,RLSE}	The value that is specified on the WFPSPACE control statement. If the control statement is not specified, the region size is estimated based on the allocation size of the partition data set.
RECFM	FB	
LRECL	7250	
VOL=SER	$volume\_name$ or *	The value that is specified on the WFPVOL control statement. If the control statement is not specified, the VOLUME parameter for the DYNALLOC macro is not set.
DSNTYPE	LARGE	

When the IPR Reload utility attempts to dynamically allocate a WFP data set and if the WFP data set already exists with the intended data set name, the IPR Reload utility deletes the existing data set and creates the data set with the same name.

#### HPSRSIDX DD

Defines an optional output work data set. If it is specified and secondary indexes are present in the DBDs being processed, the data set is used as input to utilities to resolve secondary index relationships. The use of this data set increases the performance of utilities to resolve secondary index because it has fewer records to read. DCB parameters specified within this program are RECFM=VB and LRECL=900. BLKSIZE must be provided on the HPSRSIDX DD statement. The data set must reside on either a tape or a direct-access device. This DD statement is not required if the database has no secondary index or INDEXBLD=YES is specified.

#### OVERFLOW DD

Defines an optional sequential data set that is used as a temporary storage to keep database blocks that are directed to the overflow area during HDAM RAA reloading. Such blocks are written into the overflow area after RAA reloading is completed. This data set is used only when both OADSPR=Y and HPIO=N are specified. The SPACE parameter for the DD statement must be large enough to hold all CIs or blocks in the overflow area. The DCB parameters must include RECFM=VB. This data set must reside on either a tape or a direct-access device. If both OADSPR=Y and HPIO=N are specified and this DD statement is not specified, the IPR Reload utility attempts to allocate dynamically on a direct-access device the value calculated internally according to the following method.

**Method of calculating size for dynamic allocation:** The number of database blocks directed to the overflow area during HDAM RAA reloading cannot be estimated in advance. For optimization, the IPR Reload utility calculates the cylinders for OVERFLOW DD, which can be 25% of RAA cylinders. The IPR

Reload utility uses the same value to calculate both primary and secondary values. If the calculated value is fewer than 10 cylinders, 10 cylinders are used.

The way to maintain the blocks in OVERFLOW DD is different from the one in an actual database data set, so the number of cylinders for the OVERFLOW DD is not directly comparable with the 25% of RAA cylinders.

For calculation, the IPR Reload utility uses the 3390 device type geometry regardless of the actual device type of OVERFLOW DD because the device type cannot be known before allocation. If a 3380 or a 9345 DASD is used, for example, the effective percentage of RAA of the allocation amount is a little smaller, and will be approximately 20%.

However, there is no formula to estimate the space requirement for OVERFLOW DD beforehand. The size of OVERFLOW DD depends on the amount of segments that is to be directed to the overflow part of the database. But the size equal to the overflow part of the original database is enough, until you change the DBD definition or the randomizer.

### **SORTWKnn DD**

These are intermediate storage data sets that are used by DFSORT. If SORT=YES or SORTHIDAM=YES is specified, you can define these data sets and adjust the size of workspace that is used for the sort process. You can specify multiple data sets, 'nn' showing its serial number. This specification is optional. If you do not specify the SORTWKnn DD statements, these data sets are dynamically allocated by DFSORT.

- For a (P)HDAM database, the size is estimated based on the size of RAA.
- For a HIDAM database, the size is estimated based on the primary allocation size of the primary data set group of the HIDAM database.
- For a PHIDAM database, the size is estimated based on the number of partitions.

If the number of unloaded records is provided by the RECNUM statement, this value supersedes other values and is used for estimation.

### **HPSRISMG DD**

This optional output data set contains messages issued by DFSORT. This data set is used only when ILDSBLD=YES, DSPR is specified. If the DD statement is omitted, the data set is allocated dynamically.

### **HPSRILEA DD**

### **HPSRILEB DD**

These data sets are used by DFSORT, as substitute for SORTIN data sets, when ILDSBLD=YES, DSPR is specified. If you do not specify the statement, the data sets are allocated dynamically with sizes estimated based on the allocation size of ILDS.

To avoid space shortage problems that might be caused by extension of the data sets, the size estimation is adjusted as follows:

- If the high used RBA of ILDS is greater than the primary space amount, the equivalent amount is specified as the primary space amount.
- If the secondary space amount is less than 1/5 of the high used RBA of ILDS, the equivalent amount is specified as the secondary space amount.
- If the primary or secondary space amount of ILDS is less than 100 cylinders, 100 cylinder is used as the space amount.
- The data set is allocated with volume count so that it can be extended on up to 10 volumes.

You can specify the data class and the storage class for HPSRILEA and HPSRILEB by using ILEDATAC and ILESTORC control statements.

A dummy data set or the DISP=MOD parameter cannot be specified on the HPSRILEA DD or HPSRILEB DD statement.

For more information about SORTIN data sets, see the *DFSORT Application Programming Guide*.

### HPSRWKnn DD

These data sets are used by DFSORT, as substitute for SORTWK data sets, when ILDSBLD=YES, DSPR is specified. *nn* shows its serial number. If you do not specify the statement, the data sets are allocated dynamically by DFSORT.

For more information, see *DFSORT Application Programming Guide*.

### SEQERROR DD

Defines a sequential output data set in which segment data in key sequence error is to be kept. This data set is required only if SEQERROR=SAVE is specified. This data set saves segments in key sequence error and their hierarchical dependent segments. If the DCB parameter is specified on the DD statement, the record format VB (RECFM=VB) is required. Do not specify the logical record length or the block size of the data set.

### HPSOUT DD

Defines the basic statistics output data set. The data set can reside on a tape, a direct-access device, or it can be routed through the output stream.

### HPSRAMSO DD

Defines the output data set for the Result of Database Data Set Allocation report. The data set can reside on a tape, a direct-access device, or it can be routed through the output stream. If the DD statement is not coded, it is dynamically allocated to the SYSOUT stream of the output class that is specified by the MSGCLASS parameter on the JOB statement.

### HPSSNAP DD

Defines a snap dump data set. It contains printed dumps of the DBD for user reference. The snap dump is activated with the DBDSNAP=YES specification in the HPSIN data set. The DUMMY statement can be specified if no snap dump is required.

### SYSUDUMP DD

Defines a dump data set. Most errors encountered ends the IPR Reload utility by issuing an ABEND macro with the DUMP operand. Only a SYSUDUMP DD statement is needed. The SYSABEND DD statement is not required.

#### Notes:

1. The DFSCTL data set of the IMS version is not supported.
2. Any DD name that starts with SYS, DFS, HPS, or FAB is reserved for system use.

The IPR Reload utility uses a performance default of the access method buffer number for each input and output data set. The summary of the default values is shown in the following table.

Table 73. IPR Reload utility defaults for the data set access method buffer

DDNAME	Use	Access	Default parameter	Storage used
DFSUINPT	IN	QSAM	DCB=(BUFNO=60)	private high
HPSRSIDX	OUT	QSAM	DCB=(BUFNO=40)	private low
DFSURWF1	OUT	QSAM	DCB=(BUFNO=40)	private low
HPSRPnnn	OUT	QSAM	DCB=(BUFNO=105)	private high
database	OUT	ESDS	DBIOBUF=30 (See Note 1)	private high
		OSAM LDS	DBIOBUF=30 (See Note 1)	private high
		KSDS	DBIOBUF=30 (See Note 2)	private high
		BSAM	DBIOBUF=15 (See Note 3)	private high

---

Table 73. IPR Reload utility defaults for the data set access method buffer (continued)

---

<b>DDNAME</b>	<b>Use</b>	<b>Access</b>	<b>Default parameter</b>	<b>Storage used</b>
---------------	------------	---------------	--------------------------	---------------------

---

**Notes:**

1. The IPR Reload utility calculates the number of VSAM buffers that fit into 30 tracks (that is, the default value of the DBIOBUF parameter) depending on the CI size, and specifies AMP=('BUFND=nn') in the ESDS or OSAM LDS database data set internally.
  2. The IPR Reload utility calculates the number of VSAM buffers that fit into 30 tracks (that is, the default value of the DBIOBUF parameter) depending on the CI size, and specifies AMP=('BUFND=nn,BUFNI=100') in the KSDS database data set internally. BUFNI=100 is used commonly for any CI size.
  3. The IPR Reload utility calculates the number of BSAM buffers that fit into 15 tracks (that is, the default value of the DBIOBUF parameter) depending on the block size, and specifies DCB=(NCP=nn) in the OSAM database data set internally.
-

---

## Chapter 35. IPR Reload control statements

The following topics describe the control statements supported for the HPSIN input data set.

### Topics:

- [“Syntax for the IPR Reload control statements” on page 502](#)
- [“Overview of the IPR Reload control statements” on page 502](#)
- [“BMSETDSG control statement” on page 509](#)
- [“BUFFERNO control statement” on page 510](#)
- [“BYTELIMIT control statement” on page 510](#)
- [“CHKEMPTYUL control statement” on page 511](#)
- [“CHKTRAIL control statement” on page 511](#)
- [“CHKUPDT control statement” on page 512](#)
- [“COMPAUTH control statement” on page 512](#)
- [“COMPRESS control statement” on page 513](#)
- [“DATXEXIT control statement” on page 513](#)
- [“DBDSNAP control statement” on page 514](#)
- [“DBIOBUF control statement” on page 514](#)
- [“DBRECDIST control statement” on page 515](#)
- [“DBRLBUF control statement” on page 516](#)
- [“DECODEDBD control statement” on page 516](#)
- [“EXTENT control statement” on page 516](#)
- [“FRSPC control statement” on page 517](#)
- [“GDGBASE control statement” on page 517](#)
- [“GDGLIMIT control statement” on page 517](#)
- [“HPIO control statement” on page 518](#)
- [“ILDSBLD control statement” on page 518](#)
- [“ILEDATAC control statement” on page 519](#)
- [“ILESTORC control statement” on page 519](#)
- [“INPUT control statement” on page 520](#)
- [“ITKBLOAD control statement” on page 520](#)
- [“ITKBSRVR control statement” on page 521](#)
- [“LPART control statement” on page 522](#)
- [“OADSPR control statement” on page 523](#)
- [“PAD control statement” on page 523](#)
- [“PARTINFO control statement” on page 524](#)
- [“PARTINIT control statement” on page 524](#)
- [“PROGMON control statement” on page 525](#)
- [“RAAFORMAT control statement” on page 525](#)
- [“RAPCHAIN control statement” on page 526](#)
- [“RECNUM control statement” on page 526](#)
- [“REPAIRILK control statement” on page 526](#)
- [“RMBSEGSZ control statement” on page 527](#)

- [“SEARCH control statement” on page 527](#)
- [“SEQERROR control statement” on page 527](#)
- [“SORT control statement” on page 528](#)
- [“SORTHIDAM control statement” on page 530](#)
- [“TWINSTAT control statement” on page 530](#)
- [“USERHDR control statement” on page 531](#)
- [“USERHDRX control statement” on page 532](#)
- [“WF1DSN control statement” on page 533](#)
- [“WF1REC control statement” on page 533](#)
- [“WF1SPACE control statement” on page 533](#)
- [“WF1UNIT control statement” on page 534](#)
- [“WF1VOL control statement” on page 534](#)
- [“WFPHLQ control statement” on page 534](#)
- [“WFPSPACE control statement” on page 535](#)
- [“WFPUNIT control statement” on page 535](#)
- [“WFPVOL control statement” on page 535](#)
- [“WFPVOLCNT control statement” on page 536](#)
- [“ZIIPMODE control statement” on page 536](#)

## Syntax for the IPR Reload control statements

The control statements must conform to the following syntax.

A keyword and its associated value can be coded in a free format (columns 1–80) provided these syntactical coding rules are followed:

- A keyword and its value must be on a single control statement.
- A keyword must be separated from its associated value by an equal sign (=). The equal sign must not be preceded by blanks, and not be followed by blanks; that is, a null value is not allowed.
- A comment line must begin with an asterisk (\*) in column 1.
- You can specify Y for YES and N for NO.

## Overview of the IPR Reload control statements

You can choose many options with IPR Reload utility control statements.

The following table lists the parameters you can specify in the HPSIN data set.

*Table 74. IPR Reload utility control statements for process control*

<b>Keyword</b>	<b>Accepted values</b>	<b>Default</b>	<b>Description</b>
BMSETDSG	<i>n</i> or ( <i>n1</i> , ..., <i>n10</i> ) <i>n</i> =value or *	*	Specifies the threshold value that is used to set the bitmap block. See <a href="#">“BMSETDSG control statement” on page 509</a> .

Table 74. IPR Reload utility control statements for process control (continued)

Keyword	Accepted values	Default	Description
BYTELIMIT	DBD NOLIMIT nnnnnnnn	DBD	Specifies the maximum number of bytes for a database record that can be inserted into the root addressable area. See “BYTELIMIT control statement” on page 510.
CHKEMPTYUL	YES YES,WARN YES,WARN, <i>n</i> NO	YES,WARN,4	Specifies whether to check if the unloaded data set contains segment data. See “CHKEMPTYUL control statement” on page 511.
CHKTRAIL	YES YES,WARN YES,ERROR NO	YES,WARN	Specifies whether to check for the existence of the trailer record. See “CHKTRAIL control statement” on page 511.
CHKUPDT	YES YES,ABEND YES,WARN NO	NO	Specifies whether the check for an update is done between unload and reload processes. See “CHKUPDT control statement” on page 512.
COMPAUTH	YES or NO	NO	Specifies whether to call the segment compression exit in supervisor state. See “COMPAUTH control statement” on page 512.
COMPRESS	YES or NO	YES	Compresses segments during reload. See “COMPRESS control statement” on page 513.
DATXEXIT	YES or NO	NO	Controls the IMS/ESA Year 2000 Exit Tool support. See “DATXEXIT control statement” on page 513.
DBRECDIST	<i>a</i> or ( <i>b</i> 1,..., <i>b</i> 20) <i>a</i> =0 - 9999999 <i>b</i> <i>n</i> =1 - 9999999	(100,200,300,400,500, 600,700,800,900, 1000,2000,3000, 4000,5000,6000, 7000,8000,9000, 10000)	Specifies the range of database record sizes you want to show in the Distribution of Database Record Sizes report. The range will be shown under RANGE. See “DBRECDIST control statement” on page 515.

Table 74. IPR Reload utility control statements for process control (continued)

Keyword	Accepted values	Default	Description
DECODEDBD	YES or NO	NO	Specifies whether to decode the DBD. See <a href="#">“DECODEDBD control statement”</a> on page 516.
EXTENT	1 - 120	120	Specifies the maximum number of extensions of the OSAM data set that can be created. See <a href="#">“EXTENT control statement”</a> on page 516.
FRSPC	YES or NO	YES	Secures free space factors. See <a href="#">“FRSPC control statement”</a> on page 517.
GDGBASE	YES or NO	NO	Specifies whether to create a GDG base entry. See <a href="#">“GDGBASE control statement”</a> on page 517.
GDGLIMIT	<i>nnn</i>	10	Specifies the maximum number of GDS that can be associated with the GDG that is to be created. See <a href="#">“GDGLIMIT control statement”</a> on page 517.
HPIO	YES or NO	YES	Specifies whether IMS HP Load uses High Performance I/O Driver for output data. See <a href="#">“HPIO control statement”</a> on page 518.
INPUT	DFSUINPT, <i>exitname</i> , <i>lang</i>	DFSUINPT	Specifies, the user exit routine, and its language. See <a href="#">“INPUT control statement”</a> on page 520.
ITKBLOAD	<i>libname</i> or *NO	*NO	Specifies the library name of IMS Tools KB. See <a href="#">“ITKBLOAD control statement”</a> on page 520.
ITKBSRVR	<i>servername</i> <i>servername,ERRC04</i> *NO	*NO	Specifies the name of the IMS Tools KB server XCF group. See <a href="#">“ITKBSRVR control statement”</a> on page 521.
OADSPR	YES or NO	NO	Specifies whether to reduce the usage of DSP to process (P)HDAM OA. See <a href="#">“OADSPR control statement”</a> on page 523.



Table 74. IPR Reload utility control statements for process control (continued)

<b>Keyword</b>	<b>Accepted values</b>	<b>Default</b>	<b>Description</b>
PAD	X'00' - X'FF'	X'00'	Specifies the padding character to fill out the segments to adjust to the length that is defined in the DBD definition. See <a href="#">“PAD control statement”</a> on page 523.
PROGMON	0 - 999999	0	Monitors job progress. See <a href="#">“PROGMON control statement”</a> on page 525.
RAAFORMAT	YES or NO	YES	Formats the HDAM or PHDAM RAA. See <a href="#">“RAAFORMAT control statement”</a> on page 525.
RAPCHAIN	YES or NO	NO	Specifies whether to generate the Distribution of HDAM RAP Chain Length section in the HDAM Root Addressable Area Statistics report. See <a href="#">“RAPCHAIN control statement”</a> on page 526.
RECNUM	<i>nnnnnnnnn</i>	(none)	Specifies the number of unload records that are to be reloaded. See <a href="#">“RECNUM control statement”</a> on page 526.
REPAIRILK	NO or YES	NO	Specifies whether to reassign indirect list keys (ILKs). In reassigning ILKs, the IPR Reload utility uses new RBA, partition ID, and reorganization number. See <a href="#">“REPAIRILK control statement”</a> on page 526.
RMBSEGSZ	Yes or NO	NO	Specifies how IPR Reload utility calculates the database record size to determine whether to put the records into the overflow area. See <a href="#">“RMBSEGSZ control statement”</a> on page 527.
SEARCH	-999(minus 999) - 999	3	Sets the space search boundary. See <a href="#">“SEARCH control statement”</a> on page 527.

Table 74. IPR Reload utility control statements for process control (continued)

Keyword	Accepted values	Default	Description
SEQERROR	ABEND SAVE ACCEPT	ABEND	Handles key sequence errors. See <a href="#">“SEQERROR control statement”</a> on page 527.
SORT	YES NO COND	NO	Specifies whether to run physical sequential sort before loading with (P)HDAM. See <a href="#">“SORT control statement”</a> on page 528.
SORTHIDAM	YES or NO	NO	Specifies whether to run the root key sequential sort process before loading HIDAM or PHIDAM. See <a href="#">“SORTHIDAM control statement”</a> on page 530.
TWINSTAT	YES or NO	NO	Prints statistics about the twin chained segments in the Segment Statistics report. See <a href="#">“TWINSTAT control statement”</a> on page 530.
USERHDR	<i>element</i>	(none)	Specifies the name of the elements of the header portion of the unloaded record. See <a href="#">“USERHDR control statement”</a> on page 531.
USERHDRX	<i>exitname</i>	(none)	Specifies the name of the user header conversion exit routine. See <a href="#">“USERHDRX control statement”</a> on page 532.
WF1DSN	<i>data_set_name</i> or <i>GDG_base_name.&amp;GDG</i>	(none)	Specifies the data set name for the DFSURWF1 data set when dynamically allocating the data set. See <a href="#">“WF1DSN control statement”</a> on page 533.
WF1REC	YES or NO	YES	Specifies whether to create WF1 records that are written to the DFSURWF1 output work data set. See <a href="#">“WF1REC control statement”</a> on page 533.

Table 74. IPR Reload utility control statements for process control (continued)

Keyword	Accepted values	Default	Description
WF1SPACE	CYL or TRK, <i>primary_alloc,secondary_a lloc</i>	(none)	Specifies the space parameter for the DFSURWF1 data set when dynamically allocating the data set. See “WF1SPACE control statement” on page 533.
WF1UNIT	<i>unit_name</i>	SYSALLDA	Specifies the device for the DFSURWF1 data set when dynamically allocating the data set. See “WF1UNIT control statement” on page 534.
WF1VOL	<i>volume_name</i> or *	(none)	Specifies volume names for the DFSURWF1 data set when dynamically allocating the data set. See “WF1VOL control statement” on page 534.
ZIIPMODE	COND or NEVER	NEVER	Specifies whether to offload eligible workloads to zIIP processors. See “ZIIPMODE control statement” on page 536.

The following table shows IPR Reload utility control statements for performance.

Table 75. IPR Reload utility control statements for performance

Keyword	Accepted values	Default	Description
BUFFERNO	5 - 32767	N/A	Sets the number of IPR Reload utility buffers. See “BUFFERNO control statement” on page 510.
DBIOBUF	1 - 999	30 (for VSAM), 15 (for OSAM)	Sets the amount of VSAM/OSAM buffers. See “DBIOBUF control statement” on page 514.
DBRLBUF	1 - 999	45	Sets the amount of IPR Reload utility buffers. See “DBRLBUF control statement” on page 516.

**Note:** DBRLBUF and BUFFERNO are mutually exclusive.

The following table shows IPR Reload utility control statements for partitioned databases.

Table 76. IPR Reload utility control statements for partitioned databases

Keyword	Accepted values	Default	Description
ILDSBLD	C YES YES,COND YES,DSPR YES,INITONLY NO	YES,COND	Specifies whether to build ILDS and how to do it during reorganization. See <a href="#">“ILDSBLD control statement” on page 518.</a>
ILEDATAC	<i>data_class_name</i>	(none)	Specifies the data class (DATACLAS) for the HPSRILEA and HPSRILEB data sets. See <a href="#">“ILEDATAC control statement” on page 519.</a>
ILESTORC	<i>storage_class_name</i>	(none)	Specifies the storage class (STORCLAS) for the HPSRILEA and HPSRILEB data sets. See <a href="#">“ILESTORC control statement” on page 519.</a>
LPART	( <i>partname,nnn</i> ), ( <i>part1,...,partn</i> ), or *ALL	N/A	Specifies the HALDB partitions to load. See <a href="#">“LPART control statement” on page 522.</a>
PARTINFO	YES or NO	YES	Specifies whether to generate the HALDB Partition Definition report. See <a href="#">“PARTINFO control statement” on page 524.</a>
PARTINIT	NO YES YES,PINITON YES,UNLOAD YES,LPART YES,ALL	NO	Initializes partitions not populated by any segment during reload. See <a href="#">“PARTINIT control statement” on page 524.</a>
WFPHLQ	<i>hlq</i>	(none)	Specifies the high-level qualifier for the WFP data sets. See <a href="#">“WFPHLQ control statement” on page 534.</a>
WFPSPACE	CYL or TRK, <i>primary_alloc</i> , <i>secondary_alloc</i>	(none)	Specifies the SPACE parameter for the WFP data sets when allocating WFP data sets dynamically. See <a href="#">“WFPSPACE control statement” on page 535.</a>

Table 76. IPR Reload utility control statements for partitioned databases (continued)

Keyword	Accepted values	Default	Description
WFPUNIT	<i>unit_name</i>	SYSALLDA	Specifies the device for the WFP data sets when allocating WFP data sets dynamically. See “WFPUNIT control statement” on page 535.
WFPVOL	<i>volume_name</i> or *	(none)	Specifies the volume names for the WFP data sets when allocating WFP data sets dynamically. See “WFPVOL control statement” on page 535.
WFPVOLCNT	<i>nnn</i>	(none)	Specifies the volume count for the WFP data sets when allocating WFP data sets dynamically. See “WFPVOLCNT control statement” on page 536.

The following table shows IPR Reload utility control statements for diagnosis.

Table 77. IPR Reload utility control statements for diagnosis

Keyword	Accepted values	Default	Description
DBDSNAP	YES or NO	NO	Generates the DBD Snap report. See “DBDSNAP control statement” on page 514.

## BMSETDSG control statement

Specifies the threshold value that is used to set the bitmap block of an HDAM, a HIDAM, a PHDAM, or a PHIDAM database. The value can be specified for each DSG.

This control statement is optional. The default is BMSETDSG=\*

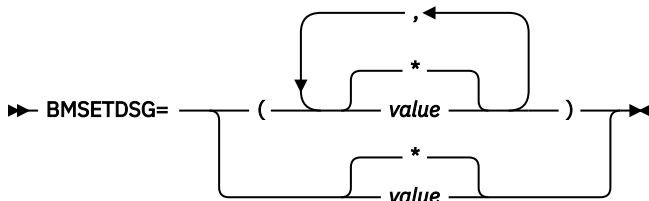

\*

Specifies to use the length of the longest segment in the data set group in the same manner as IMS.

**value**

Specifies to use a threshold value, in the range of 3 - 32000, for the data set group.

You can specify one parameter or a list of parameters. If one parameter is specified, it is used for the first data set group of the database. Otherwise, parameters must be separated by commas and enclosed in parentheses. The N-th parameter will be used for the N-th data set group. You can specify up to 10. If the number of the value specified is less than the number of data set groups, '\*' is used for other data set groups for which values are not specified.

### Example 1:

```
BMSETDSG=1000
```

The threshold value for the first DSG of the database is 1000.

### Example 2:

```
BMSETDSG=(1000,*,1200)
```

The threshold value for the first DSG is 1000 and the value for the third DSG is 1200. For other DSGs, the length of the longest segment in the data set group is used.

## BUFFERNO control statement

Specifies the number of database buffers that are used for one database data set group when reading or writing the database.

This statement is mutually exclusive with the DBRLBUF statement. Determine whether you use DBRLBUF to specify the amount of database buffers or use BUFFERNO to specify the number of database buffers.

The size of a database buffer is almost the same as the CI or block size of the database data set group. Because the database buffers are acquired by the data set group, the total number of database buffers is the sum of database buffers in each data set group.

This control statement is optional. If this control statement is not specified, the DBRLBUF specification is used. If neither control statement is specified, DBRLBUF=45 is used.

```
➔ BUFFERNO= nnnnn ➔  
   └───┬───┘  
       BUFNO=
```

The abbreviation BUFNO= can be used for BUFFERNO=.

#### **nnnnn**

Specifies a left-aligned decimal number in the range of 5 - 32767. This statement does not have a default value.

**Tip:** You can reduce EXCPs by increasing the amount of database buffers. The amount of database buffers must be greater than the amount of access method buffers + 10 tracks. If the amount of database buffers is insufficient, the IPR Reload utility internally adjusts the amount of database buffers. Select the suitable value for the number of database buffers based on your execution environment.

## BYTELIMIT control statement

Specifies the maximum number of bytes for a database record that can be inserted into the root addressable area.

This specification is applicable only to HDAM and PHDAM databases.

This control statement is optional. If you do not specify this control statement, BYTELIMIT=DBD is used.

```
➔ BYTELIMIT= ┌─── DBD ───┐  
              │ nnnnnnnn │  
              └─── NOLIMIT ─┘ ➔
```

#### **DBD**

Specifies that the value is obtained from the DBD or the RECON data sets.

#### **nnnnnnnn**

Specifies a left-aligned decimal number in the range of 1 - 16777215.

#### **NOLIMIT**

Specifies that there is no limit on the maximum number of bytes.

## CHKEMPTYUL control statement

Specifies whether to check if the unloaded data set contains segment data. Also, specifies the return code that is set when no segment data is found in the unloaded data set.

If DUMMY is specified on the DFSUINPT DD statement, this check is not applicable.

This control statement is optional. If you do not specify this control statement, CHKEMPTYUL=YES,WARN,4 is used.

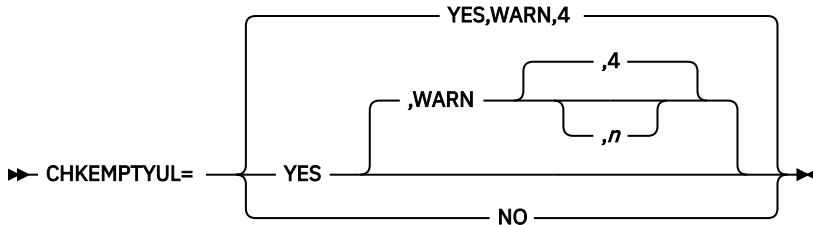

### YES

Specifies to check if segment data exists in the unloaded data set.

### WARN,*n*

Sets the job step return code to *n* when the unloaded data set contains no segment data. For *n*, specify a left-aligned decimal number in the range of 1 - 4.

If you specify CHKEMPTYUL=YES or CHKEMPTYUL=YES,WARN, CHKEMPTYUL=YES,WARN,4 is assumed.

### NO

Specifies not to check if segment data exists in the unloaded data set. The return code is not changed even when no segment data exists in the unloaded data set.

The return code that you specify with CHKEMPTYUL can be overridden by a higher return code set for some other reason.

**Tip:** You can change the default value of this control statement by creating an Installation Default Option Table (HPSCOPTI). For more information, see [Chapter 45, "Setting installation default options," on page 617](#).

## CHKTRAIL control statement

Specifies whether to check if a trailer record exists in the \*HD or \*SH format of the unload data set.

This control statement is optional. The default is CHKTRAIL=YES,WARN.

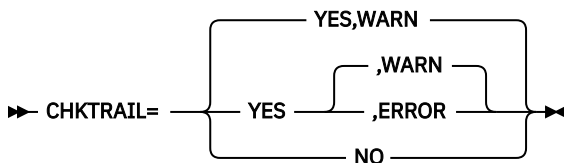

### YES

Specifies that the existence of the trailer record is checked.

### WARN

Specifies IPR Reload to continue processing, setting the job step return code to 4 when a trailer record is not found in the unload data set. If you specify only CHKTRAIL=YES, CHKTRAIL=YES,WARN is assumed.

### ERROR

Specifies IPR Reload to end with return code 16 when a trailer record is not found in the unload data set.

**NO**

Specifies that the existence of trailer record is not checked. IPR Reload continues processing even if a trailer record does not exist in the unload data set.

**Tip:** You can change the default value of this control statement by creating an Installation Default Option Table (HPSCOPTI). For more information, see [Chapter 45, “Setting installation default options,”](#) on page 617.

## CHKUPDT control statement

---

Specifies whether you want to do an IPR Reload utility check against DBRC to see if an update of the database has been done between unload and reload processes.

The control statement is optional. The default is CHKUPDT=NO.

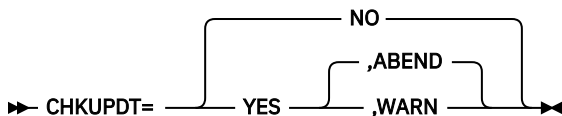
**NO**

Specifies that update is not checked.

**YES**

Specifies that update between unload and reload is checked.

**ABEND**

Specifies IPR Reload utility to end abnormally when an update is found. If you specify only CHKUPDT=YES, CHKUPDT=YES,ABEND is assumed.

**WARN**

Specifies that IPR Reload utility continue processing with setting the job step return code to 4 when an update is found.

The check against DBRC for an update is activated when all the following conditions are met:

- DBRC is active.
- Database and database data sets are registered to DBRC.
- The unloaded data set was created by the IPR Unload utility with the CHECKREC=YES option

**Tip:** You can change the default value of this control statement by creating an Installation Default Option Table (HPSCOPTI). For more information, see [Chapter 45, “Setting installation default options,”](#) on page 617.

## COMPAUTH control statement

---

Specifies whether to call the segment compression exit in supervisor state.

**Tip:** If you use an encryption exit of InfoSphere Guardium Data Encryption for Db2 and IMS Databases as the segment compression exit, specifying COMPAUTH=YES reduces performance degradation. Even if the input data for the IPR Reload utility is created in compressed (encrypted) format, it is recommended to specify COMPAUTH=YES to reduce performance degradation because the IPR Reload utility calls the encryption exit to decrypt segment data for internal processes in some conditions.

This control statement is optional. If you do not specify this control statement, COMPAUTH=NO is used.

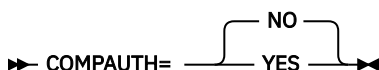
**NO**

Specifies to call the segment compression exit in problem state.



**YES**

Specifies to call the segment compression exit in supervisor state.

**Notes:**

- If you specify COMPAUTH=YES, you must APF-authorize the load module libraries that are specified on the STEPLIB DD.
- If one or more libraries on the STEPLIB DD are not APF-authorized, the IPR Reload utility uses COMPAUTH=NO even if you specify COMPAUTH=YES.

**Tip:** You can change the default value of this control statement by creating an Installation Default Option Table (HPSCOPTI). For more information, see [Chapter 45, “Setting installation default options,”](#) on page 617.

## COMPRESS control statement

---

Specifies whether you want to use a segment compression exit.

This statement activates or deactivates calling the segment compress routine for all segment types with COMPRTN specified on their related SEGM statements in the DBD.

This control statement is optional. The default is COMPRESS=YES.

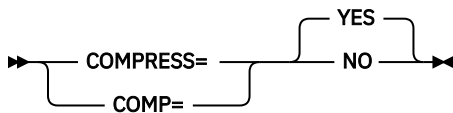

The abbreviation COMP= can be used for COMPRESS=.

**YES**

Specifies that segments be compressed if a compression routine is specified for them.

**NO**

Specifies that segments not be compressed if a compression routine is specified for them.

If you use the IPR Unload utility output as input, you do not need to specify the COMPRESS= parameter because the IPR Reload utility can automatically determine whether the segments are in the compressed format. To avoid specification errors, it is recommended that you do not specify this parameter.

The COMPRESS= parameter is required only if the input data set is created by a utility other than the IPR Unload utility or IMS HP Unload, and is in a compressed format.

**Notes:**

- An unloaded data set created by the IPR Unload utility with the DECOMPRESS=NO option cannot be used as input for the IMS HD Reorganization Reload utility. If you use it, the HD reload job issues DFS388A and ends with return code 16.
- An unloaded data set created by the IPR Unload utility with the DECOMPRESS=NO option cannot be used if you want to change the size of the segment during reorganization.

This control statement is in effect for all the database segments with COMPRTN= specified on their related SEGM statements in the DBD. This option cannot be selectively activated or deactivated for some compressed segments.

## DATXEXIT control statement

---

Specifies whether you want to activate the IMS/ESA Year 2000 Exit Tool (5697-E04) support.

This control statement is optional. The default is DATXEXIT=NO.

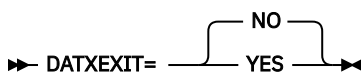

**YES**

Activates the IMS/ESA Year 2000 Exit Tool support. The IPR Reload utility treats the IMS/ESA Year 2000 Exit Tool in the same way that IMS does.

**NO**

Deactivates the IMS/ESA Year 2000 Exit Tool support. The IPR Reload utility does not call the IMS/ESA Year 2000 Exit Tool exit routine (the DFSDBUX1 exit routine) regardless of the DATXEXIT parameter in the DBD.

Use this option in conjunction with the DATXEXIT=NO option in the IPR Unload utility job that creates an unloaded data set in the stored form.

If DATXEXIT=YES is specified in the HPSIN data set, the IPR Reload utility calls the DFSDBUX1 exit routine if it exists in the STEPLIB. As the result of the first call of the DFSDBUX1 exit routine, the IPR Reload utility determines which segment type in the database needs to be converted. Afterward, the IPR Reload utility does not call the DFSDBUX1 exit routine for any segment type determined not to be converted.

When the segment types determined to be converted are unloaded in the compressed format by an IPR Unload utility job with the DECOMPRESS=NO option, the IPR Reload utility calls the segment edit/compression exit routine to decompress such segments before calling the DFSDBUX1 exit routine, and calls it again after the DFSDBUX1 exit routine to recompress the segments. Decompression and recompression are performed even if COMPRESS=NO is specified in the HPSIN data set.

If the segment data requires the DFSDBUX1 exit routine to be called and if a user exit routine is specified on the INPUT control statement, the IPR Reload utility calls the user exit routine to edit or delete the segment data first, and then calls the DFSDBUX1 exit routine to convert the segment data.

If DATXEXIT=NO is specified in the HPSIN data set, the IPR Reload utility does not call the DFSDBUX1 exit routine even if it is in the STEPLIB. A user exit routine, if used, receives segment data not converted (in the stored form).

**Note:** If you use SEQERROR=SAVE in conjunction with DATXEXIT=NO, the SEQERROR data set will contain segments in the stored form because the IPR Reload utility does not deconvert such segments. You cannot use such segments in the stored form for reinsertion because IMS/ESA Year 2000 Conversion Exit converts it again during DL/I insertion.

## DBDSNAP control statement

---

Specifies whether you want to generate a snap dump report of the DBD.

This control statement is optional. The default is DBDSNAP=NO.

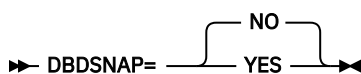
**NO**

Specifies that a DBD snap dump report is not generated.

**YES**

Specifies that a DBD snap dump report is generated.

## DBIOBUF control statement

---

Specifies the number of tracks for the access method (VSAM or BSAM) buffers that are used for one database data set group when the database is read or written to.

The IPR Reload utility translates the specified number into the AMP= or DCB= (NCP=) parameter value internally. If the translated value exceeds the maximum allowable value for each access method, the translated value is overwritten. If you specify the AMP= or the DCB= (NCP=) parameter for the database DD statement, it precedes the DBIOBUF= specification.

This control statement is optional. The default is DBIOBUF=30 for ESDS and OSAM LDS, and DBIOBUF=15 for OSAM. In the case of HISAM, DBIOBUF=15 is applied. For OSAM LDS, DBIOBUF=15 is printed in the HPSIN Control Statements report even if DBIOBUF=30 is applied.

➤ DBIOBUF= *nnn* ➤

***nnn***

Specifies a left-aligned decimal number in the range of 1 - 999.

## DBRECDIST control statement

Specifies whether to generate the Distribution of Database Record Sizes report, and if so, the range of database record sizes in bytes.

This control statement is optional. If you do not specify this control statement, the default values are used.

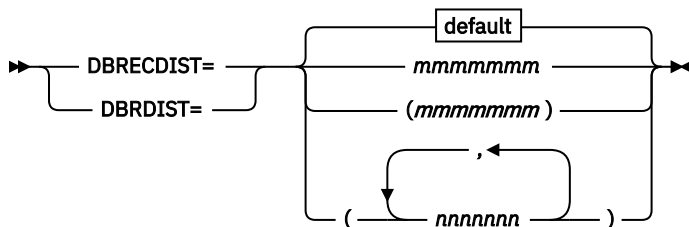

***default***

The following values are used for the default of RANGE:

(100,200,300,400,500,600,700,800,900,  
1000,2000,3000,4000,5000,6000,7000,8000,9000,10000)

***mmmmmmm***

Specify a 7-digit decimal number in the range of 0 - 9999999. The leading zeros can be omitted. If you do not want to generate the Distribution of Database Record Sizes report, specify 0.

***nnnnnnn***

Specify a 7-digit decimal number in the range of 1 - 9999999. The leading zeros can be omitted. For *nnnnnnn*, you can specify up to 20 different 7-digit decimal numbers in ascending order.

You can specify up to 20 values for the range (RANGE) of Distribution of Database Record Sizes report. If you want to specify multiple values for the range, you can either specify multiple 7-digit decimal numbers for *nnnnnnn*, or specify the value for the range in multiple DBRECDIST control statements. When you specify multiple DBRECDIST control statements, the statements do not need to be consecutive, but the value of the range must be in ascending order.

**Example of a normal case:**

```

DBRECDIST=(1,2,3,4)
OUTPUT=SYSUT3
DBRECDIST=5
DBRECDIST=(6,7,8,9,10)

```

**Example of an error case:**

```

DBRECDIST=(5,6,7,8,9,10)
DBRECDIST=(1,2,3,4)

```

This control statement is ignored for SHISAM databases.

## DBRLBUF control statement

---

Specifies the amount (the number of tracks) of database buffers that are used for one database data set group when reading or writing the database.

This statement is mutually exclusive with the BUFFERNO statement. Determine whether you use DBRLBUF to specify the amount of database buffers, or use BUFFERNO to specify the number of database buffers. With the DBRLBUF statement, you can specify the buffer amount more directly, without calculating the value using the CI size or the block size of each database data set.

Because the database buffers are acquired by the data set group, the total amount of database buffers is the sum of database buffers in each data set group.

This control statement is optional. The default is DBRLBUF=45 (that is, a buffer size of 45 tracks). In the case of HISAM, DBRLBUF=2 is used.

➤ DBRLBUF= *nnn* ➤

***nnn***

Specifies a left-aligned decimal number in the range of 1 - 999.

**Tip:** You can reduce EXCPs by increasing the amount of database buffers. The amount of database buffers must be greater than the amount of access method buffers + 10 tracks. If the amount of database buffers is insufficient, the IPR Reload utility internally adjusts the amount of database buffers. Select an appropriate value for the amount of database buffers based on your execution environment.

## DECODEDBD control statement

---

Specifies whether to decode the DBD and print the resulting DBD source statements in the Decoded DBD report.

This control statement requires IMS Library Integrity Utilities. See [“Software prerequisites” on page 39](#).

This control statement is optional. The default is DECODEDBD=NO.

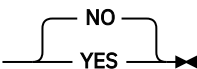
➤ DECODEDBD=  ➤

**YES**

Specifies to decode the DBD.

**NO**

Specifies not to decode the DBD.

For HIDAM databases, the DBDs for the primary database and the primary index are decoded.

**Tip:** You can change the default value of this control statement by creating an Installation Default Option Table (HPSCOPTI). For more information, see [Chapter 45, “Setting installation default options,” on page 617](#).

## EXTENT control statement

---

Specifies the maximum number of extensions of the OSAM data set that can be created.

When IPR Reload detects an extension number that is greater than the EXTENT control statement value, IPR Reload issues message HPSR3739E and ends abnormally:

- If HPIO=YES, IPR Reload checks the extension number during the reorganization. It checks the number every time an extent is allocated. The job could end abnormally during the reorganization.
- If HPIO=NO, IPR Reload checks the extension number after the reorganization. The job ends abnormally only after the reorganization.

This control statement is optional. The default is EXTENT=120.

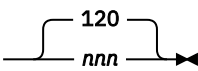
▶▶ EXTENT= 

**nnn**

Specifies a left-aligned decimal number in the range of 1 - 120.

If the OSAM data set is created on EAV, this control statement is ignored.

**Tip:** You can change the default value of this control statement by creating an Installation Default Option Table (HPSCOPTI). For more information, see [Chapter 45, “Setting installation default options,”](#) on page 617.

## FRSPC control statement

---

Specifies whether the IPR Reload utility secures free space according to the specification of the FRSPC parameter in DBD.

This control statement is optional. The default is FRSPC=YES.

▶▶ FRSPC= 

**YES**

Free space is secured according to the specification of the DBD.

**NO**

Free space is not secured. The specification of the DBD is ignored.

## GDGBASE control statement

---

Specifies whether to create a generation data group (GDG) base entry when a GDG base entry does not exist.

This control statement is optional. The default is GDGBASE=NO.

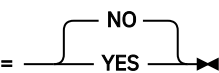
▶▶ GDGBASE= 

**YES**

If there is no GDG base entry for the generation data set that is to be created and if the generation data set is to be allocated dynamically, a GDG base entry is created.

**NO**

GDG base entry is not created.

**Tip:** You can change the default value of this control statement by creating an Installation Default Option Table (HPSCOPTI). For more information, see [Chapter 45, “Setting installation default options,”](#) on page 617.

## GDGLIMIT control statement

---

Specifies the maximum number of generation data sets (GDS) that can be associated with the generation data group (GDG) that is to be created. This specification is valid only when GDGBASE=YES is specified.

This control statement is optional. The default is GDGLIMIT=10.

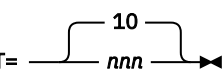
▶▶ GDGLIMIT= 

**nnn**

Specifies a left-justified decimal number in the range of 1 - 255.

**Tip:** You can change the default value of this control statement by creating an Installation Default Option Table (HPSCOPTI). For more information, see [Chapter 45, “Setting installation default options,”](#) on page 617.

## HPIO control statement

Specifies whether the IPR Reload utility uses High Performance I/O Driver for output database data sets.

This control statement is optional. If you do not specify this control statement, the value for the HPIO option is determined as follows: If the libraries specified on the STEPLIB DD statement are not APF-authorized, HPIO=NO is used; otherwise, HPIO=YES is used.



### YES

High Performance I/O Driver is used for output database data sets.

### NO

High Performance I/O Driver is not used for output database data sets.

### Notes:

- For HISAM or SHISAM data sets, HPIO=NO is assumed. If you specify HPIO=YES, it is ignored. If HPIO=NO is specified, the APF authorization of libraries specified in STEPLIB DD is not necessary.
- If you want to specify the HPIO control statement for the all subtasks of the Smart Reorg utility, including the IPR Reload utility task, it is recommended that you specify the HPIO control statement in the (REORG) block. In this case, the specification of the HPIO control statement in the (RELOAD) block is ignored. If you want to specify the HPIO control statement for each subtask of the Smart Reorg utility, you must not specify the HPIO control statement in the (REORG) block explicitly. For more information about the HPIO control statement for the (REORG) block, see [“HPIO control statement”](#) on page 137.

**Tip:** You can change the default value of this control statement by creating an Installation Default Option Table (HPSCOPTI). For more information, see [Chapter 45, “Setting installation default options,”](#) on page 617.

## ILDSBLD control statement

Specifies whether to build ILDS and how to build the ILDS.

This control statement is optional. The default is ILDSBLD=YES,COND.

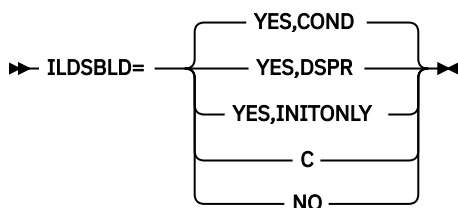

### YES,COND

Applies either YES,DSPR or YES,INITONLY. If both of the following conditions are met, YES,INITONLY is applied. Otherwise, YES,DSPR is applied.

- WFPHLQ=*hlq* is specified.
- HALDB has no logical relationships defined.

## YES,DSPR

ILDS is rebuilt with using less amount of data space than the obsolete option ILDSBLD=YES.

In the process of rebuilding, the records of ILDS are arranged in sequence of the key value by using DFSORT. If you do not specify those DD statements, HPSRILEA, HPSRILEB, and HPSRWKnn work data sets, which are used as SORTIN and SORTWK data sets, are allocated dynamically.

You can specify the data class and the storage class for the HPSRILEA and HPSRILEB data sets by using the ILEDATAC and ILESTORC control statements.

## YES,INITONLY

The ILDS is initialized but no ILEs are built. Use ILDSBLD=YES,INITONLY only when the HALDB has no logical relationships and you want to rebuild PSINDEXes in a separate job by using IMS Index Builder.

## C

ILDS is rebuilt in the same manner of IMS HD Reorganization Reload.

If the database is an OSAM database, ILDSBLD=C is changed to ILDSBLD=YES,DSPR.

## NO

ILDS is not built. In this case, you must rebuild ILDS after the reorganization of the database. To do this, scan the reorganized database by using IMS HALDB Index/ILDS Rebuild utility (DFSRECO).

**Note:** ILDSBLD=YES is obsolete. If you specify ILDSBLD=YES, ILDSBLD=YES,COND is used.

**Tip:** You can change the default value of this control statement by creating an Installation Default Option Table (HPSCOPTI). For more information, see [Chapter 45, “Setting installation default options,” on page 617](#).

## ILEDATAC control statement

---

Specifies the name of the data class for the HPSRILEA and HPSRILEB data sets.

This control statement is optional. This control statement does not have a default value.

►► ILEDATAC= *data\_class\_name* ◄◄

### *data\_class\_name*

Specifies the name of the data class for the HPSRILEA and HPSRILEB data sets.

This control statement is effective only when ILDSBLD=YES,DSPR is in effect. If any other ILDSBLD option is used, this control statement is ignored.

**Tip:** You can change the default value of this control statement by creating an Installation Default Option Table (HPSCOPTI). For more information, see [Chapter 45, “Setting installation default options,” on page 617](#).

## ILESTORC control statement

---

Specifies the name of the storage class for the HPSRILEA and HPSRILEB data sets.

This control statement is optional. This control statement does not have a default value.

►► ILESTORC= *storage\_class\_name* ◄◄

### *storage\_class\_name*

Specifies the name of the storage class for the HPSRILEA and HPSRILEB data sets.

This control statement is effective only when ILDSBLD=YES,DSPR is in effect. If any other ILDSBLD option is used, this control statement is ignored.

**Tip:** You can change the default value of this control statement by creating an Installation Default Option Table (HPSCOPTI). For more information, see [Chapter 45, “Setting installation default options,” on page 617](#).

## INPUT control statement

Specifies an optional user exit routine to be applied before the input segment data is passed to the loading process.

This control statement is optional. The default is INPUT=DFSUINPT.

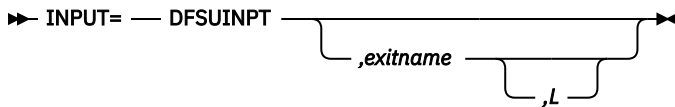

The first parameter is provided for the compatibility with version 1 of IMS Parallel Reorganization, and DFSUINPT is the only acceptable keyword. You do not need to specify the first parameter.

The IPR Reload utility reloads an unloaded data set specified in the DFSUINPT DD statement in one of the following formats (created by the IPR Unload utility) or in an equivalent format that is created by a compatible program:

- The HD format
- The HD format with compressed segments
- The short header format
- The communication industry standard format (see [notes](#))
- The communication industry partitioned format (see [notes](#))

### Notes:

- If the database has a logical relationship with another database, the IPR Reload utility cannot reload a data set in either the communication industry standard format or the communication industry partitioned format.
- If the database is a HALDB, the IPR Reload utility cannot reload a data set in either the short header format or the communication industry standard format.
- If the database is a SHISAM DB, the communication industry standard format is not supported.
- If the database is a non-HALDB, the IPR Reload utility cannot reload a data set in the communication industry partitioned format.

The IPR Reload utility determines which format is being used; you do not have to specify it.

### *exitname*

The name of a user exit routine. Specify this operand if you use the exit interface of the IPR Reload utility. The specified exit routine must reside in a STEPLIB library.

### **L**

Specify this operand only if the user exit routine is run under an environment of Language Environment. This option is effective when the user exit routine is written in Enterprise COBOL for z/OS or Enterprise PL/I for z/OS. This option is not effective for either assembly language or VS COBOL II.

## ITKBLOAD control statement

Specifies the name of the load module library for IMS Tools KB.

This control statement is used only when ITKBSRVR=*servername* is specified. If you do not specify this control statement, ITKBLOAD=\*NO is used and IPR Reload utility attempts to load the IMS Tools KB module from the STEPLIB libraries.

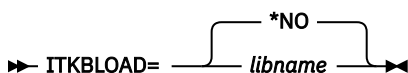



**\*NO**

The IMS Tools KB modules are loaded from the private library or the system library of the job.

**libname**

Specifies the name of the IMS Tools KB load module data set that is to be used by the IPR Reload utility.

When STEPLIB needs to be APF-authorized, this library also needs to be APF-authorized.

**Tip:** You can change the default value of this control statement by creating an Installation Default Option Table (HPSCOPTI). For more information, see [Chapter 45, “Setting installation default options,”](#) on page 617.

## ITKBSRVR control statement

---

Specifies the name of the IMS Tools KB server XCF group.

This control statement is optional. The default is ITKBSRVR=\*NO.

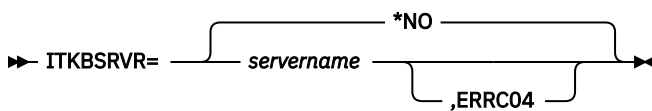
**\*NO**

IPR Reload utility does not store reports in the IMS Tool KB Output repository.

**servename**

IPR Reload utility stores several reports in the IMS Tools KB Output repository of the specified server.

**servename,ERRC04**

IPR Reload utility returns return code 4 when it encounters IMS Tools KB errors.

If ITKBSRVR=*servename* is specified, IPR Reload utility attempts to connect to the server and then to store the following reports in the Output repository of IMS Tools KB:

- Environment
- HPSIN Control Statements
- DBD Summary
- HALDB Partitions Processed
- Segment Count Summary
- Segment Statistics
- HDAM Root Addressable Area Statistics
- Distribution of Database Record Sizes
- HISAM Statistics
- Data Set Statistics
- Pointer Count Summary
- Pointer Statistics
- HALDB Partition Definition

See [“HPSOUT data set”](#) on page 541 for a list of report names that are used in IMS Tools KB.

**Requirement:** ITKBSRVR=*servename* requires that an appropriate version of IMS Tools KB is installed and the server is started. For more information, see [“Software prerequisites”](#) on page 39 and [“Store the reports in the Output repository of IMS Tools KB”](#) on page 486.

**Tip:** You can change the default value of this control statement by creating an Installation Default Option Table (HPSCOPTI). For more information, see [Chapter 45, “Setting installation default options,”](#) on page 617.

## LPART control statement

Specifies the HALDB partitions to load.

Use the LPART statement to specify the partitions to load when one or more of the following conditions are met:

- When the database data sets are created by using the DDEFPS DD statement (IDCAMS commands) and the input unloaded data set is not created by the IPR Unload utility with the CHECKREC=YES option.
- When the database data sets are created by using the DDEFPS DD statement (IDCAMS commands) and you have added new partitions after unloading the database.
- When you have added new partitions after unloading the database and you have one or more empty new partitions that you want to initialize with the PARTINIT=YES,LPART option.

**Tip:** To avoid errors, consider specifying this statement only when one or more of these conditions are met.

If the unload data sets contain segments for the partitions that are not specified on the LPART control statement, the IPR Reload utility issues an HPSR3768W message and continues processing.

This control statement is optional. This control statement does not have a default value.

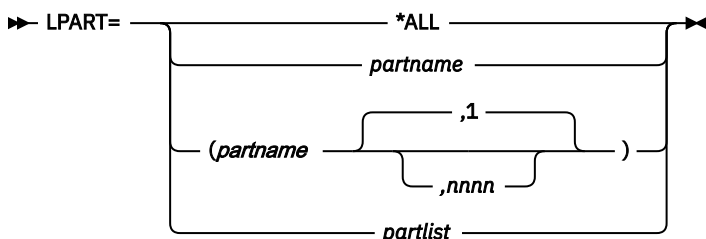

### **\*ALL**

Specifies to load all the partitions. Use this option only when you reorganize the entire database and the input unloaded data set contains data for all the partitions.

### **partname**

Specifies the name of the partition to load, or the first partition of several sequential partitions to load.

### **nnnn**

Specifies the number of sequential partitions to load. If this parameter is not specified, the default value of 1 is assumed.

**Important:** The processing order of the partitions is determined by the HALDB partition selection exit routine or the HALDB high key values. The processing order does not depend on the partition names. When you process multiple partitions, be aware of the processing order.

For example, the following statements have the same meaning:

```
LPART=PARTA
LPART=(PARTA)
LPART=(PARTA,1)
```

### **partlist**

Specifies a list of the partition names to load. The names must be separated by commas and enclosed in parentheses. You can specify up to 1001 names by using multiple statements as follows:

```
LPART=(part1,part2,part3,part4,part5)
LPART=(part6,part7,part8,part9,part10)
```

You can specify non-sequential partitions.

The processing order of the partitions is determined by the HALDB partition selection exit routine or the HALDB high key values. The specified order in the list does not affect the processing order.

## OADSPR control statement

Specifies whether the IPR Reload utility reduces the usage of data space (DSP) when processing the overflow area by using the High Performance I/O Driver or by using an OVERFLOW DD.

This specification is valid only for HDAM or PHDAM databases. This control statement is optional. The default is OADSPR=NO.

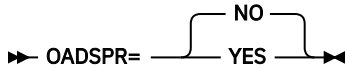

### YES

Reduces the usage of DSP when processing the overflow area.

### NO

Does not reduce the usage of DSP when processing the overflow area.

### Notes:

- If you specify both OADSPR=YES and HPIO=YES, the IPR Reload utility attempts to reduce the usage of data space by using the High Performance I/O Driver. It can also reduce the time for reload except when IPR Type-A Image Copy processing is used for a (P)HDAM that has extremely large overflow area.
- If you specify both OADSPR=YES and HPIO=NO, the IPR Reload utility attempts to reduce the usage of data space by using an OVERFLOW DD as a temporary data set. If the DD statement is not specified in the JCL, the IPR Reload utility attempts to allocate it dynamically on a direct-access device. For details, see [Chapter 34, “IPR Reload JCL requirements,”](#) on page 491.
- This function might not be able to reduce the usage of data space depending on the DB. Because the IPR Reload utility keeps the data in a data space until the information for pointers in the block are resolved.

**Tip:** You can change the default value of this control statement by creating an Installation Default Option Table (HPSCOPTI). For more information, see [Chapter 45, “Setting installation default options,”](#) on page 617.

## PAD control statement

Specifies the padding character to fill out the segments to adjust to the length that is defined in the DBD definition.

The segments are padded in the following cases:

- When a segment edit/compression exit is not used and the length of fixed-length segments is increased because the DBD definition changed.
- When a segment edit/compression exit is used and the length of fixed-length segments is shorter than the maximum number of bytes defined by the COMPRTN parameter in the DBD definition.
- When the length of variable-length segments is shorter than the minimum segment length defined in the DBD definition.

This control statement is optional. The default is PAD=X'00'.

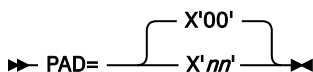

### nn

The 2-digit hexadecimal code for the padding character. For example, PAD=X'FF'.

**Tip:** You can change the default value of this control statement by creating an Installation Default Option Table (HPSCOPTI). For more information, see [Chapter 45, “Setting installation default options,”](#) on page 617.

## PARTINFO control statement

Specifies whether to generate the HALDB Partition Definition report.

This control statement is valid only for HALDBs; the statement is ignored for non-HALDBs.

This control statement is optional. The default is PARTINFO=YES.

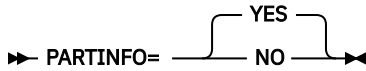

### YES

The HALDB Partition Definition report is generated.

### NO

The HALDB Partition Definition report is not generated.

Information specified on this statement affects the number of lines written to the HPSOUT data set. For more information, see [“HPSOUT data set” on page 541](#).

**Tip:** You can change the default value of this control statement by creating an Installation Default Option Table (HPSCOPTI). For more information, see [Chapter 45, “Setting installation default options,” on page 617](#).

## PARTINIT control statement

Specifies whether to initialize HALDB partitions after reload. IMS HP Load initializes a HALDB partition when a HALDB partition does not contain any segment during reload.

The PARTINIT control statement is valid only for a HALDB.

This control statement is optional. The default is PARTINIT=NO.

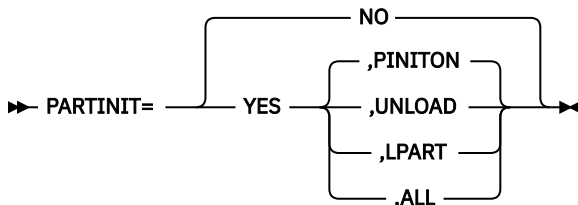

### NO

Specifies that any initialization of a HALDB partition is not to be performed after reload.

### YES

Specifies that initialization of a HALDB partition is to be performed for partitions that are not populated by any segment during reload.

#### **PINITON**

Specifies that initialization of a HALDB partition is to be done when the flag in the DBRC RECON record for the partition shows that the partition needs to be initialized (PINIT). If you only specify PARTINIT=YES, PARTINIT=YES,PINITON is assumed.

#### **UNLOAD**

Specifies that initialization of a HALDB partition is to be done when the partition information is included in the input unloaded data set. The initialization is to be done regardless of the PARTITION INIT NEEDED flag in the DBRC RECON record. To use this option, the following conditions must be satisfied:

- The input unloaded data set has been created by the IPR Unload utility or IMS HP Unload with the CHECKREC=YES option.
- The input unloaded data sets are not concatenated.

**LPART**

Specifies that HALDB partitions are initialized when the partitions to be loaded are specified by the LPART control statement.

**ALL**

Specifies to initialize all the HALDB partitions that are not populated by any segments during reload.

Use this option only when you request reorganization of all the HALDB partitions.

If you want to use the IPR Reload utility as a replacement for the HALDB partition data set initialization utility, specify the PARTINIT=YES control statement and DFSUINPT DD DUMMY for the IPR Reload utility JCL, and run it.

IPR Reload utility issues a warning message if the partition was not initialized by the following reasons:

- PARTINIT=YES,PINITON is specified. But the flag in the RECON shows that the partition does not need to be initialized (NOPINIT).
- PARTINIT=YES,UNLOAD is specified. But the partition information is not found in the unloaded data set.

The following conditions must be satisfied to issue the warning message:

- The input unloaded data set has been created by the IPR Unload utility or IMS HP Unload with the CHECKREC=YES option.
- The input unloaded data sets are not concatenated.

**Tip:** You can change the default value of this control statement by creating an Installation Default Option Table (HPSCOPTI). For more information, see [Chapter 45, “Setting installation default options,”](#) on page 617.

## PROGMON control statement

---

Specifies whether the IPR Reload utility issues a progress monitoring message at the specified intervals.

This control statement is optional. The default is PROGMON=0 (that is, no progress monitoring message is issued).

➤➤ PROGMON= *nnnnnn* ➤➤

***nnnnnn***

Specifies a left-aligned decimal number in the range of 0 - 999999. After every *nnnnnn* database record are processed, the IPR Reload utility issues a progress monitoring message.

## RAAFORMAT control statement

---

Specifies whether the IPR Reload utility formats RAA blocks of an HDAM or PHDAM database regardless of the number of blocks used.

Once the overflow area is used, this parameter is ignored and the complete RAA is formatted. This specification is valid only for HDAM and PHDAM databases.

This control statement is optional. The default is RAAFORMAT=YES.

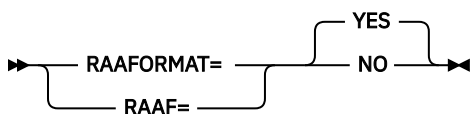

The abbreviation RAAF= can be used for RAAFORMAT=.

**YES**

The complete RAA is formatted.

## NO

The complete RAA is not formatted. The RAA is formatted through the last block used.

## RAPCHAIN control statement

---

Specifies whether to generate the Distribution of HDAM RAP Chain Length section in the HDAM Root Addressable Area Statistics report.

This control statement is valid only for an HDAM or a PHDAM database; the statement is ignored for other databases.

This control statement is optional. The default is RAPCHAIN=NO.

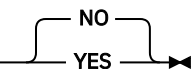
►► RAPCHAIN=  ►►

## YES

The Distribution of HDAM RAP Chain Length section is generated.

## NO

The Distribution of HDAM RAP Chain Length section is not generated.

**Note:** Even if YES is specified for this control statement, if the input database records are not in the order of BBBR, this control statement is ignored.

## RECNUM control statement

---

Specifies the number of unloaded records to be reloaded. It helps to optimize the DFSORT main storage and the allocation of the intermediate storage data sets.

This control statement is optional. This control statement does not have a default. You can use this control statement only when you specify SORT=YES/COND or SORTHIDAM=YES.

►► RECNUM= *nnnnnnnnnn* ►►

*nnnnnnnnnn*

Specifies a left-aligned decimal number in the range of 1 - 2147483647.

## REPAIRILK control statement

---

Specifies whether to reassign indirect list keys (ILKs) in the segment prefix portion. In reassigning ILKs, the IPR Reload utility uses new RBA, partition ID, and reorganization number.

This control statement is optional. The default is REPAIRILK=NO.

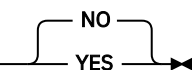
►► REPAIRILK=  ►►

## NO

ILKs are not reassigned.

## YES

ILKs are reassigned based on the new RBA, partition ID, and reorganization number.



### Attention:

- If you want to reassign ILKs by specifying REPAIRILK=YES, ensure that the entire HALDB (that is, all the partitions of the HALDB) is reorganized with the REPAIRILK=YES option. Otherwise, you might encounter problems caused by duplicate segment ILKs.
- If you specify REPAIRILK=YES, you must rebuild the PSINDEX for the target HALDB because ILKs are changed.

**Restriction:** Logical relationships are not supported.

**Tip:** You can change the default value of this control statement by creating an Installation Default Option Table (HPSCOPTI). For more information, see [Chapter 45, “Setting installation default options,”](#) on page 617.

## RMBSEGSZ control statement

---

specifies how the IPR Reload utility calculates the database record size to determine whether to put the records to the overflow area.

This control statement is optional. The default is RMBSEGSZ=NO.

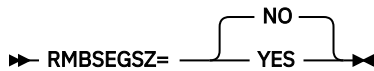

### YES

The actual size of the variable length segment (the LL value) is used to calculate the database record size. This is applicable also for the compressed segment.

### NO

The MINBYTES value specified on the DBD is used to calculate the database record size.

This specification is valid for HDAM and PHDAM databases that have the variable length segment. If databases other than HDAM and PHDAM databases that have the variable length segments are specified, the IPR Reload utility ignores them.

## SEARCH control statement

---

Specifies the limit value for the space search algorithm that locates a segment that does not fit in its home block.

The IPR Reload utility searches the specified number (*nnn*) of adjacent blocks both forward and backward for free space. This specification is valid only for HDAM and PHDAM databases.

To search available free space for segment insertion, the IPR Reload utility simply ignores the SCAN parameter in DBD and uses the SEARCH parameter to process reloading faster.

This control statement is optional. The default is SEARCH=3.

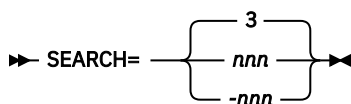

### *nnn*

Specifies a left-aligned decimal number in the range of 0 - 999. The IPR Reload utility searches the specified number of adjacent blocks both forward and backward.

### *-nnn*

Specifies a left-aligned decimal number in the range of -999 - -0. The IPR Reload utility searches the specified number of adjacent blocks only backward.

### 0 and -0

Both mean to bypass space search, putting the segment into the overflow area, and not printing the HDAM Root Placement section in the HDAM Root Addressable Area Statistics report.

## SEQERROR control statement

---

Specifies how to handle key sequence errors in the input unloaded data.

This control statement is optional. The default is SEQERROR=ABEND.

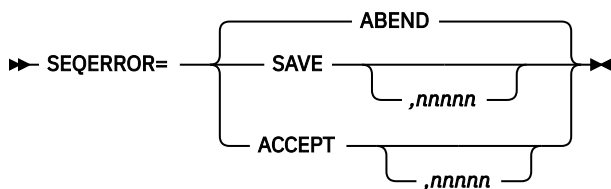

## ABEND

Issues a user abend after a key sequence error.

## SAVE

Continues processing after key sequence errors. Segments in error and their dependent segments are all placed in the SEQERROR data set.

If you specify this option, you must specify the SEQERROR DD statement.

You can write a DL/I program to insert segments saved in the SEQERROR data set into the database after database reload completes. A sample user application is provided in SHPSSAMP of IMS HP Load with the member name FABFSQEI.

If you use the SEQERROR=SAVE option for a database with a logical relationship, the SEQERROR data set might contain logical child segments in key sequence error. Do not reinsert such logical child segments with a user-written DL/I insert program; otherwise, you receive the DL/I status code II.

**Note:** When root keys of HDAM or PHDAM are not in the physical sequence order of the block and RAP numbers, the IPR Reload utility issues a user abend even if SEQERROR=SAVE is specified.

## nnnnn

Specifies the maximum number of sequence errors. *nnnnn* must be a left-aligned decimal number in the range of 1 - 32767. If the number of sequence errors exceeds this value, the IPR Reload utility issues a user abend. If this value is not specified, the IPR Reload utility accepts any number of key sequence errors.

## ACCEPT

Specifies that processing is to continue after key sequence errors of dependent segments, and that the segments that contain errors are placed in the database with those errors. For a key sequence error of root segments, the IPR Reload utility issues a user abend.

The root keys of HIDAM, HISAM, SHISAM, or PHIDAM must be in the correct ascending sequential order without duplication.

The root keys of HDAM or PHDAM must be in the physical sequence order of the block and RAP numbers. If a root segment that has duplicate key is found, the root segment will be placed in the synonym chain in the database. The details of each key sequence error are displayed in the Messages report.

## nnnnn

Specifies the maximum number of sequence errors. *nnnnn* must be a left-aligned decimal number in the range of 1 - 32767. If the number of sequence errors exceeds this value, the IPR Reload utility issues a user abend. If this value is not specified, the IPR Reload utility accepts any number of key sequence errors.

If you specify SEQERROR=SAVE or ACCEPT, the numbers of occurrences of key sequence errors are listed in the Segment Count Summary report by segment type.

## SORT control statement

Specifies whether to run the physical sequential sort processing before reloading.

This specification is valid only for HDAM and PHDAM databases.

The HDAM or PHDAM unloaded data must be in the order of hexadecimal value *bbbbbbrr* that represents the result of randomizing module conversion. *bbbbbb* is the block number and *rr* is the RAP number.



If it is not in that order due to such reasons as changing randomizer, you must specify SORT=YES or SORT=COND.

This control statement is optional. The default is SORT=NO.

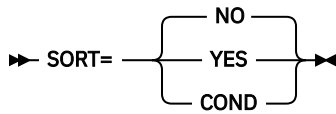

### YES

Runs physical sequential sorting before the reload process. It sorts in the physical sequence of the block, then the RAP numbers.

### NO

Does not run the sort process.

### COND

Runs the physical sequential sorting depending on conditions. To use this option, the input unloaded data set must be created by the IPR Unload utility or IMS HP Unload with the CHECKREC=YES option and the format of the unloaded data set must be in the HD format or in the short header format.

The physical sequential sorting is done if any of the following is changed between the unload and the reload processes:

- The randomizing module name
- The number of root anchor points (RAP)
- The maximum BLK/CI number in RAA
- The starting position of the root key
- The length of the root key
- Whether the root segment has key sequence field
- DB organization is changed from (P)HIDAM to (P)HDAM.

When using the IPR Reload utility or when using the Smart Reorg utility with REORGINPUT=ULDS, the physical sequential sorting is done whenever the following conditions are satisfied:

- The input unloaded data set was not created by the IPR Unload utility or IMS HP Unload with the CHECKREC=YES option.
- The input unloaded data set was created in the communication industry standard format.
- The input unloaded data sets are concatenated.

**Warning:** For the following changes, you must specify SORT=YES instead of SORT=COND because these changes cannot be detected by IMS HP Load with SORT=COND:

- The logic of the randomizing module
- The name or logic of the HALDB partitions selection exit routine
- The partition selection string or the high key values

### Restrictions:

- This statement is used exclusively with the DATXEXIT=YES control statement.
- The key value that is sorted by SORT=YES or SORT=COND cannot be changed by the user exit routine.
- The compressed root key cannot be sorted. Specify DECOMPRESS=YES in the IPR Unload utility to expand the compressed key.

**Note:** If the workspace of DFSORT needs to be adjusted, specify SORTWKnn DD statements.

**Tip:** You can change the default value of this control statement by creating an Installation Default Option Table (HPSCOPTI). For more information, see [Chapter 45, "Setting installation default options,"](#) on page 617.

## SORTHIDAM control statement

---

Specifies whether to run the sort processing before loading a HIDAM or a PHIDAM.

The HIDAM or PHIDAM unloaded data must be in the order of root keys. If it is not in that order because the root keys are changed after unloading, you must specify SORTHIDAM=YES. This control statement is optional. The default is SORTHIDAM=NO.

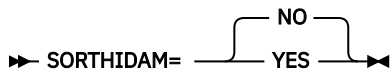

### NO

Does not run the sort process.

### YES

Runs the key sequential sort process before the reload process. The sort is done in the order of the root keys.

### Restrictions:

- This control statement cannot be used for the Load API.
- The key value that is sorted by SORTHIDAM=YES cannot be changed by the user exit routine that is specified in the reload step.
- Compressed root keys cannot be sorted. Specify DECOMPRESS=YES in the IPR Unload utility to expand the compressed keys.
- HPSRSVX2 exit cannot run with SORTHIDAM=YES.

**Note:** For a HIDAM database, DFSORT allocates intermediate storage data sets dynamically for the sort process with sizes estimated on the basis of the primary allocation size of DBDS. For a PHIDAM database, the size is estimated based on the number of partitions. If you specify the number of unloaded records in the RECNUM control statement, this value supersedes other values and is used for estimation. If you need to adjust the size, specify the SORTWKnn DD statements explicitly.

## TWINSTAT control statement

---

Specifies whether to print statistics about the twin chained segments.

The statistics about the twin chained segments are printed in the Twin Segment Statistics section in the Segment Statistics report. For an example of the report, see [“Segment Statistics report”](#) on page 554.

The TWINSTAT control statement is effective for HDAM, HIDAM, PHDAM, and PHIDAM databases.

This control statement is optional. The default is TWINSTAT=NO.

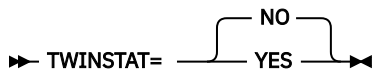

### NO

Statistics about the twin chained segments are not printed.

### YES

Statistics about the twin chained segments are printed.

If you process a HALDB with TWINSTAT=YES, PARTSTAT=YES is internally used. The statistics reports, which include the twin segment statistics section, are generated for each partition.

If you specify TWINSTAT=YES in the (RELOAD) block of the Smart Reorg utility, you must also specify STATRL=YES or the HPSSTAT DD statement.

**Tip:** You can change the default value of this control statement by creating an Installation Default Option Table (HPSCOPTI). For more information, see [Chapter 45, “Setting installation default options,”](#) on page 617.

## USERHDR control statement

Specifies the name of the element of the header portion of the unloaded record to read the customized unload file.

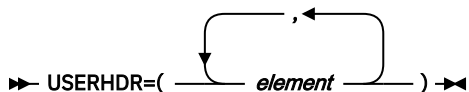

### **element**

Describes an element that constitutes the user header portion of the unloaded file. You can select up to 22 elements from Table 78 on page 531. You can use any combination of them as parameters of the USERHDR control statement.

The order in which you specify the elements determines the order that the elements appear in the user header portion of the unloaded file.

If the specification exceeds one line, specify:

```
//HPSIN DD *
USERHDR=(DBDNAME,SEGCODE,SEGLEV1,SEGNAME)
USERHDR=(SEGDATSZ,SEGKEY,FILLER11)
/*
```

Table 78. Description and values of the elements of USERHDR

Element name	Length (bytes)	Type	Description
DBDNAME	8	Character	DBD name
FILLER $nn$ ( $nn=01-99$ )	$nn$	Hex	The suffix $nn$ defines the length of the field. The field is filled with binary zeros.
FLAG	1	Flag byte	Flag byte X'80': Compressed form
HDRLEN	2	Hex	Length of the header portion.
ROOTKEY	Variable	-	Sequence key of the root segment. The length is variable.
ROOTRBA	4	Hex	RBA of the root segment.
SEGCKEY	Variable	-	Concatenated key of the segment. The length is variable and is contained in SEGCKYSZ.
SEGCKYSZ	2	Hex	Length of the concatenated key of the segment.
SEGCODE	1	Hex	Segment code
SEGDATSZ	2	Hex	Length of the data portion of the segment.
SEGDBYTE	1	Flag byte	The delete flag of the segment.
SEGKEY	Variable	-	Sequence key of the segment. The length is variable and is contained in SEGKEYSZ.
SEGKEYOF	2	Hex	Offset of the sequence key in the data portion of the segment.
SEGKEYSZ	2	Hex	Length of the sequence key of the segment.
SEGLEV1	1	Hex	Segment level
SEGLEV2	2	Character	Segment level

Table 78. Description and values of the elements of USERHDR (continued)

Element name	Length (bytes)	Type	Description
SEGNAME	8	Character	Segment name
SEGRBA	4	Hex	RBA of the segment

**Restrictions and requirements:**

- You cannot specify the USERHDR control statement and the USERHDRX control statement at the same time because they are mutually exclusive.
- HALDBs are not supported.
- Databases that have logical relationships are not supported.
- A header or a trailer record must not reside in the unloaded file.
- You cannot duplicate keywords other than FILLERnn.
- You must specify COMPRESS=NO if the segment data of unloaded file is in a compressed form.
- You must specify the SEGNAME or the SEGCODE keyword. They must precede the SEGCKY, the SEGKEY, or the ROOTKEY element.
- If you use SEGKEY, SEGCKEY, or ROOTKEY, you must specify HDRLEN. It must precede the SEGKEY, the SEGCKEY, or the ROOTKEY element.

## USERHDRX control statement

Specifies whether the IPR Reload utility invokes a user header conversion exit routine.

This control statement is optional. If you do not specify this control statement, no user header conversion exit routine is invoked.

➤ USERHDRX= *exitname* ➤

For the detailed description of this exit routine, see the *IMS High Performance Load User's Guide*.

The IPR Reload utility has several exit routines, and you can specify one of them as the parameter of USERHDRX according to the format of the unloaded file, as shown in the following table.

Table 79. Exit routine names and the formats of the unloaded file

Exit routine name	Format of the unloaded file
HPSRCVA3	*A3
HPSRCVA4	*A4
HPSRCVF1	*F1
HPSRCVF2	*F2
HPSRCVF3	*F3
HPSRCVF6	*F6

For example, if the format of the unloaded file is \*F1, specify the HPSRDVF1 conversion exit routine.

You cannot specify the USERHDRX control statement and the USERHDR control statement at the same time. They are mutually exclusive.

## WF1DSN control statement

---

Specifies the data set name for the DFSURWF1 data set that is to be dynamically allocated.

This control statement is optional and does not have a default.

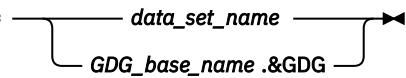
➤ WF1DSN=  ➤

### **data\_set\_name**

Specifies the data set name for the DFSURWF1 data set. The name is a 1-44 alphanumeric or national characters (\$,#,@).

### **GDG\_base\_name.&GDG**

Specifies to create a DFSURWF1 data set as a generation data set. &GDG must be specified in the last position in the pattern. *GDG\_base\_name* is used as a GDG base entry name. If the base entry does not exist and you specify GDGBASE=YES, a new GDG base entry is created. The data set name generated must be a 1-44 alphanumeric or national characters (\$,#,@).

**Note:** If you specify the DFSURWF1 DD statement, this control statement is ignored.

## WF1REC control statement

---

Specifies whether to create WF1 records that are written to the DFSURWF1 or HPSRSINDX output work data set, which are used as input to resolve a logical or secondary index relationships. The WF1REC control statement is not valid for a HALDB.

This control statement is optional. The default is WF1REC=YES.

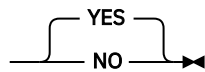
➤ WF1REC=  ➤

### **YES**

If the database has a logical relationship or a secondary index, the records are written to the DFSURWF1 output work data set.

### **NO**

WF1 records are not written to the DFSURWF1 or the HPSRSINDX output work data set even if secondary index or logical relationships are defined in the database.

To resolve the secondary index, you must run a database scan utility in a separate job step.

**Note:** The DFSURWF1 data set is needed to run the IMS Database Prefix Resolution utility for logical relationships after this reload job step. For such non-HALDBs, do not specify WF1REC=NO.

## WF1SPACE control statement

---

Specifies the space parameter for the DFSURWF1 data set that is to be dynamically allocated. This specification is valid only when WF1DSN is specified.

If you do not specify this control statement, IPR Reload calculates the size on the basis of the allocation size of database data set. This control statement is optional and does not have a default.

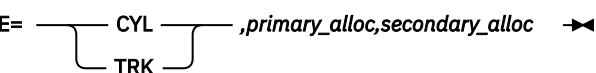
➤ WF1SPACE=  ➤

### **CYL**

Specifies that space is to be allocated in cylinders.

### **TRK**

Specifies that space is to be allocated in tracks.

**primary\_alloc**

Specifies the primary space quantity. It must be a left-justified decimal number in the range of 1 - 9999.

**secondary\_alloc**

Specifies the secondary space quantity. It must be a left-justified decimal number in the range of 1 - 9999.

**Note:** If you specify the DFSURWF1 DD statement, this control statement is ignored.

## WF1UNIT control statement

Specifies the device for the DFSURWF1 data set that is to be dynamically allocated. This specification is valid only when WF1DSN control statement is specified.

This control statement is optional. The default is WF1UNIT=SYSALLDA.

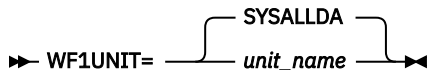

**unit\_name**

Specifies the device type or the device group name for the DFSURWF1 data set.

**Note:** If you specify the DFSURWF1 DD statement, this control statement is ignored.

## WF1VOL control statement

Specifies one or more volume names for DFSURWF1 data set that is to be dynamically allocated. This specification is valid only when WF1DSN control statement is specified.

This control statement is optional and does not have a default.

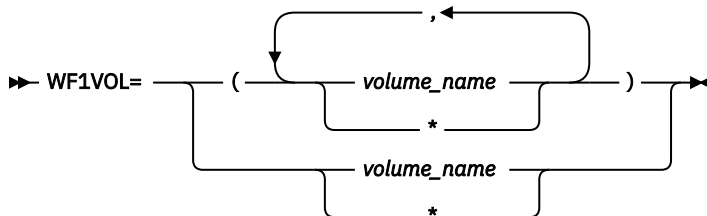

**volume\_name**

Specifies the volume names. You can make a nonspecific volume request by specifying an asterisk (\*). Two or more volume names must be separated by commas and enclosed in parentheses. For example, WF1VOL=(VOLSR1,VOLSR2). You can specify up to 5 volume names.

**Note:** If you specify the DFSURWF1 DD statement, this control statement is ignored.

## WFPHLQ control statement

Specifies the high-level qualifier for the WFP data sets.

This control statement is required only when you want to create WFP data sets. This control statement does not have a default value.



**hlq**

Specifies the high-level qualifier for the WFP data sets. It must be 1-32 alphanumeric or national characters (\$, #, @).

## WFPSPACE control statement

Specifies the SPACE parameter for the WFP data sets when allocating WFP data sets dynamically.

This control statement is effective only when a WFPHLQ control statement is specified.

If you do not specify this control statement, the IPR Reload utility estimates the size based on the allocation size of the partition data set. This control statement is optional and it does not have a default value.

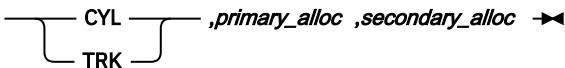
►► WFPSPACE=  ►►

### CYL

Specifies that space is to be allocated in cylinders.

### TRK

Specifies that space is to be allocated in tracks.

### *primary\_alloc*

Specifies the primary space quantity. It must be a left-aligned decimal number in the range of 1 - 9999.

### *secondary\_alloc*

Specifies the secondary space quantity. It must be a left-aligned decimal number in the range of 1 - 9999.

## WFPUNIT control statement

Specifies the device for the WFP data sets when allocating WFP data sets dynamically.

This control statement is effective only when a WFPHLQ control statement is specified.

This control statement is optional. The default is WFPUNIT=SYSALLDA.

►► WFPUNIT= *unit\_name* ►►

### *unit\_name*

Specifies the device type or the device group name for WFP data sets.

## WFPVOL control statement

Specifies the device for the WFP data sets when allocating WFP data sets dynamically.

This control statement is effective only when a WFPHLQ control statement is specified.

This control statement is optional and it does not have a default value.

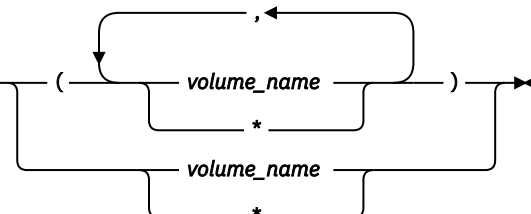
►► WFPVOL=  ►►

### *volume\_name*

Specifies the volume names. You can indicate nonspecific volumes by designating an asterisk (\*).

Two or more volume names must be separated by commas and enclosed in parentheses. For example, WFPVOL=(VOLSR1,VOLSR2). You can specify up to five volume names.

## WFPVOLCNT control statement

---

Specifies the device for the WFP data sets when allocating WFP data sets dynamically.

This control statement is effective only when a WFPHLQ control statement is specified.

This control statement is optional and it does not have a default value.

►► WFPVOLCNT= *nnn* ►►

### *nnn*

Specifies the number of allowable volumes for allocating the WFP data sets. The value is a decimal number in the range of 1 - 59 for a DASD data set.

## ZIIPMODE control statement

---

Specifies whether IPR Reload utility offloads eligible I/O workloads to zIIP processors.

This control statement is optional. The default is ZIIPMODE=NEVER.

►► ZIIPMODE=  ►►

### **COND**

Offloads VSAM ESDS I/O or OSAM LDS I/O workloads to zIIP processors. COND is effective only when available zIIP processors are found. Otherwise, the job is run on the main CPs.

The following conditions must be satisfied to apply ZIIPMODE=COND:

- The SGLXLOAD library of IMS Tools Base is specified to the STEPLIB.
- The load module libraries of STEPLIB are APF authorized.
- The High Performance I/O Driver is activated.

If the High Performance I/O driver is inactive for some reason, even if you specify ZIIPMODE=COND, ZIIPMODE=NEVER is applied.

### **NEVER**

Does not offload any workload to zIIP processors. NEVER is the default to avoid unexpected performance degradation.

**Tip:** You can change the default value of this control statement by creating an Installation Default Option Table (HPSCOPTI). For more information, see [Chapter 45, “Setting installation default options,”](#) on page 617.



## Chapter 36. IPR Reload JCL examples

The following examples present the effective uses of the IPR Reload utility.

### Topics:

- [“Example 1: As a part of the reorganization process” on page 537](#)
- [“Example 2: Creating an empty database” on page 538](#)
- [“Example 3: Reloading a database in an IMS-managed ACBs environment” on page 538](#)
- [“Example 4: Reloading a database with the IMS Catalog Definition exit routine” on page 539](#)

### Example 1: As a part of the reorganization process

This example is for using the IPR Reload utility as a part of the reorganization process.

The HDAM/HIDAM database reorganization process with no logical relationship consists of three steps. The execution of the IPR Reload utility is used for one of these steps:

1. Database unload step (using the IPR Unload utility)
2. Allocation step
3. Database reload step (using the IPR Reload utility)

Figure 179 on page 537 shows an example of JCL unload a VSAM HDAM database, Figure 180 on page 537 to allocate a new VSAM database data set, and Figure 181 on page 538 to reload a VSAM HDAM database. The VSAM HDAM database reload step also prints statistical reports. DBRC is not being used.

```
//UNLOAD EXEC PGM=HPSCMAIN, PARM= ' FUNC=UL, DBD=DBSAMP01 '  
//STEPLIB DD DSN=HPS.SHPSLMD0, DISP=SHR  
// DD DSN=IMS.RESLIB, DISP=SHR  
//DFSRESLB DD DSN=IMS.RESLIB, DISP=SHR  
//IMS DD DSN=IMS.DBDLIB, DISP=SHR  
//HPSOUT DD SYSOUT=A  
//SYSUDUMP DD SYSOUT=A  
//*  
//DBSAMP01 DD DSN=DBSAMP01.DATA1, DISP=OLD  
//SYSUT2 DD DSN=DBSAMP01.UNLOAD, DISP=(NEW, PASS),  
// SPACE=(CYL, (20, 10))
```

Figure 179. Sample JCL stream to unload an HDAM database

```
//*-----*  
//* ALLOCATE NEW DATABASE (DATA : VSAM ESDS) *  
//*-----*  
//ALLOC EXEC PGM=IDCAMS  
//SYSPRINT DD SYSOUT=A  
//SYSIN DD *  
DELETE (DBSAMP01.RELOAD.DATA1) CLUSTER  
DEFINE CLUSTER -  
 (NAME (DBSAMP01.RELOAD.DATA1) NONINDEXED -  
 VOL(*) -  
 RECORDSIZE (2041,2041) -  
 CONTROLINTERVALSIZE (2048) -  
 SPEED -  
 CYL(20 10))  
/*
```

Figure 180. Sample JCL stream to allocate a new database data set

```
//RELOAD EXEC PGM=HPSCMAIN, PARM= ' FUNC=RL ,DBD=DBSAMP01 '
//STEPLIB DD DSN=HPS.SHPSLMD0, DISP=SHR
// DD DSN=IMS.RESLIB, DISP=SHR
//IMS DD DSN=IMS.DBDLIB, DISP=SHR
//HPSOUT DD SYSOUT=A
//SYSUDUMP DD SYSOUT=A
//*
//DBSAMP01 DD DSN=DBSAMP01.RELOAD.DATA1, DISP=OLD
//DFSUINPT DD DSN=DBSAMP01.UNLOAD, DISP=(OLD, PASS)
```

Figure 181. Sample JCL stream to reload an HDAM database

## Example 2: Creating an empty database

There are occasions when you need an empty database, particularly in the online environment. This is an example for such a case.

For example, IMS does not allow you to create an HD-type database online. To circumvent this restriction, you create a database offline by inserting one root segment and then deleting it. This *initializes* the database so that it can be used online.

The IPR Reload utility performs this *initialization* function simply by the JCL statement modification. Insertion of the following JCL statement creates a usable empty database:

```
//DFSUINPT DD DUMMY
```

If this is an HDAM database, the entire root addressable area is pre-formatted. This improves online performance when segments are inserted to this database.

## Example 3: Reloading a database in an IMS-managed ACBs environment

If the IMS management of ACBs is enabled, you can reload a database without specifying the DBD library on the IMS DD statement.

Use the following JCL example to reload a database in an IMS-managed ACBs environment.

```
//RELOAD EXEC PGM=HPSCMAIN, PARM= ' FUNC=RL ,DBD=DBSAMP01 ,DBRC=Y ,DFSDF=CAT '
//STEPLIB DD DSN=HPS.SHPSLMD0, DISP=SHR
// DD DSN=ITKBHLQ.SGLXLOAD, DISP=SHR
// DD DSN=IMS.RESLIB, DISP=SHR
//PROCLIB DD DSN=IMS.PROCLIB, DISP=SHR
//HPSOUT DD SYSOUT=A
//SYSUDUMP DD SYSOUT=A
//*
//DBSAMP01 DD DSN=DBSAMP01.RELOAD.DATA1, DISP=OLD
//DFSUINPT DD DSN=DBSAMP01.UNLOAD, DISP=(OLD, PASS)
//DFSACBPD DD *
STAGING
/*
```

Figure 182. Sample JCL stream to reload an HDAM database in an IMS-managed ACBs environment

In this example:

- DFSDF=CAT parameter is specified on the EXEC statement. This parameter specifies the DFSDFCAT member that enables IMS-managed ACBs.
- The name of the IMS.PROCLIB data set in which the DFSDFCAT member exists is specified on the PROCLIB DD statement.
- The name of the SGLXLOAD library of IMS Tools Base is specified on the STEPLIB DD statement.
- The keyword STAGING is specified on the DFSACBPD DD statement. This keyword specifies to reload with the pending changes from the staging data sets in IMS catalog.
- IMS DD is not specified.

You must allocate the catalog partition definition data set when reloading a database with DBRC=NO. To do so, add the DFSHDBSC DD statement or the DFSMDA member with the TYPE=CATDBDEF statement.

## Example 4: Reloading a database with the IMS Catalog Definition exit routine

If the IMS management of ACBs is enabled, you can reload a database without specifying the DBD library on the IMS DD statement.

Use the following JCL example to reload a database in an IMS-managed ACBs environment with the IMS Catalog Definition exit routine (DFS3CDX0).

```
//RELOAD EXEC PGM=HPSCMAIN, PARM= ' FUNC=RL, DBD=DBSAMP01, DBRC=Y'
//STEPLIB DD DSN=HPS.SHPSLMD0, DISP=SHR
// DD DSN=ITKBHLQ.SGLXLOAD, DISP=SHR
// DD DSN=IMS.RESLIB, DISP=SHR
//HPSOUT DD SYSOUT=A
//SYSUDUMP DD SYSOUT=A
//*
//DBSAMP01 DD DSN=DBSAMP01.RELOAD.DATA1, DISP=OLD
//DFSUIIPT DD DSN=DBSAMP01.UNLOAD, DISP=(OLD, PASS)
//DFSACBPD DD *
STAGING
/*
```

Figure 183. Sample JCL stream to reload an HDAM database with the DFS3CDX0 exit routine

In this example:

- The DFS3CDX0 exit routine must be bound to IMS.RESLIB or a concatenated library.
- The name of the SGLXLOAD library of IMS Tools Base is specified on the STEPLIB DD statement.
- The keyword STAGING is specified on the DFSACBPD DD statement. This keyword specifies to reload with the pending changes from the staging data sets in IMS catalog.
- IMS DD is not specified.

You must allocate the catalog partition definition data set when reloading a database with DBRC=NO. To do so, add the DFSHDBSC DD statement or the DFSMDA member with the TYPE=CATDBDEF statement.



---

## Chapter 37. IPR Reload reports

The IPR Reload utility produces the reports and statistics in the HPSOUT data set and the HPSSNAP data set.

### Topics:

- [“HPSOUT data set” on page 541](#)
- [“HPSSNAP data set: DBD Snap report” on page 578](#)

---

### HPSOUT data set

The HPSOUT data set is the basic statistics output data set. It contains several reports generated by the IPR Reload utility.

This data set contains the following printed reports:

- Environment report
- Default Option Tables report
- HPSIN Control Statements report
- Decoded DBD report
- DBD Summary report
- Messages report
- HALDB Partitions Processed report
- Segment Count Summary report
- Segment Statistics report <sup>5</sup>
- HDAM Root Addressable Area Statistics report <sup>5</sup>
- Distribution of Database Record Sizes report <sup>5</sup>
- HISAM Statistics report
- Data Set Statistics report <sup>5</sup>
- I/O Statistics report <sup>5</sup>
- Pointer Count Summary report
- Pointer Statistics report
- WFP Process Summary report
- HALDB Partition Definition report
- DBRC Messages report
- GDG Base Information report

When the IPR Reload reports are stored in the Output repository of IMS Tools KB, the report names that are defined in IMS Tools KB are used for managing the reports. The following table lists the report names that are used in IMS Tools KB.

---

<sup>5</sup> For HALDBs, the report is generated for each partition that is processed. When the high key selection is used, the report is generated in the order of the high key, and when the partition selection exit is used, it is generated in the order of the partition name.

Table 80. IPR Reload report names used in IMS Tools KB

Report name	Long title	Short title
Data Set Statistics report	IPRRL-DATA SET STATISTICS	RL-DATA SET STATISTICS
DBD Summary report	IPRRL-DBD SUMMARY	RL-DBD SUMMARY
Distribution of Database Record Sizes report	IPRRL-DISTRIBUTION OF DATABASE RECORD SIZES	RL-DB RECORD SIZES DIST
Environment report	IPRRL-ENVIRONMENT	RL-ENVIRONMENT
HALDB Partition Definition report	IPRRL-HALDB PARTITION DEFINITION	RL-HALDB DEFINITION
HALDB Partitions Processed report	IPRRL-HALDB PROCESSED	RL-HALDB PROCESSED
HDAM Root Addressable Area Statistics report	IPRRL-HDAM ROOT ADDRESSABLE AREA STATISTICS	RL-HDAM RAA STATISTICS
HISAM Statistics report	IPRRL-HISAM STATISTICS	RL-HISAM STATISTICS
HPSIN Control Statements report	IPRRL-HPSIN CONTROL STATEMENTS	RL-HPSIN CONTROL STMT
Pointer Count Summary	IPRRL-POINTER COUNT SUMMARY	RL-POINTER COUNT SUMMARY
Pointer Statistics	IPRRL-POINTER STATISTICS	RL-POINTER STATISTICS
Segment Count Summary report	IPRRL-SEGMENT COUNT SUMMARY	RL-SEGMENT COUNT
Segment Statistics report	IPRRL-SEGMENT STATISTICS	RL-SEGMENT STATISTICS

## Environment report

The EXEC parameters specified for the job and the system environment information are printed in this report.

The following figure shows an example of the Environment report.

```

IMS HIGH PERFORMANCE LOAD                                PAGE:      1
5655-M26                                                11/01/2023 10.32.14

                                "ENVIRONMENT"

EXEC PARAMETERS

DATABASE TO REORGANIZE..... PHD00300
GLOBAL SERVICE GROUP NAME..... YES
ACTIVATE DBRC..... YES
ACTIVATE IRLM FOR NATIVE DL/I CALLS... YES
  IRLM SUBSYSTEM NAME..... IRLM
MAKE ADDRESS SPACE SWAPPABLE..... YES

SYSTEM ENVIRONMENT

OPERATING SYSTEM..... z/OS 02.04.00
STORAGE MANAGEMENT..... DFSMS/zOS 02.04.00
IMS..... IMS 15.1.0
PRODUCT VERSION..... IMS DB REORG EXPERT V4.1.0
PROCESSOR TYPE..... 3906
NUMBER OF PROCESSOR(S)..... 2

```

Figure 184. Environment report for the IPR Reload utility

The meanings of the fields in the Environment report are as follows:

#### **EXEC PARAMETERS**

Information about each keyword specified in the EXEC statement.

#### **DATABASE TO REORGANIZE**

The DBD name of the database specified as the DBD= parameter in the EXEC statement.

#### **GLOBAL SERVICE GROUP NAME**

The name of the global service group (GSG) to be used for the RSR complex specified as the GSGNAME= parameter in the EXEC statement. If the GSGNAME= parameter is not specified, (SYSTEM DEFAULT) is displayed.

#### **ACTIVATE DBRC**

Status of use of DBRC specified as the DBRC= parameter in the EXEC statement.

- If DBRC=Y is specified, YES is displayed.
- If DBRC=N is specified, NO is displayed.
- If the DBRC= parameter is not specified, the default setting determined by IMS system generation is used.

#### **ACTIVATE IRLM FOR NATIVE DL/I CALLS**

Status of use of IRLM specified as the IRLM= parameter in the EXEC statement.

- If IRLM=Y is specified, YES is displayed.
- If IRLM=N is specified, NO is displayed.
- If the IRLM= parameter is not specified, (SYSTEM DEFAULT) is displayed.

#### **IRLM SUBSYSTEM NAME**

The IRLM subsystem name specified as the IRLMNM= parameter in the EXEC statement. This item is displayed only if IRLM=Y is specified.

- If IRLM=Y is specified and if the IRLMNM= parameter is not specified, (SYSTEM DEFAULT) is displayed.
- If IRLM=N is specified or if the IRLM= parameter is not specified, this item is not displayed, no lines altogether.

#### **MAKE ADDRESS SPACE SWAPPABLE**

Specifies whether to enable or disable the swapping of address space specified as the SWAP= parameter in the EXEC statement.

- If SWAP=Y is specified, YES is displayed.
- If SWAP=N is specified or if the SWAP= parameter is not specified, NO is displayed.

#### **SYSTEM ENVIRONMENT**

Information about the system environment.

#### **OPERATING SYSTEM**

The release level of the operating system.

#### **STORAGE MANAGEMENT**

The release level of the storage management subsystem.

#### **IMS**

The release level of IMS.

#### **IPR**

The release level of IMS Database Reorganization Expert.

#### **PROCESSOR TYPE**

The type number of the central processor.

#### **NUMBER OF PROCESSOR(S)**

The number of physical processors.

## Default Option Tables report

This report contains the contents of the System Default Option Table (HPSCOPTS) and the Installation Default Option Table (HPSCOPTI).

If HPSCOPTI was used, this report shows both HPSCOPTS and HPSCOPTI. If HPSCOPTS was used, this report shows only HPSCOPTS. For more information about the Installation Default Option Table, see Chapter 45, "Setting installation default options," on page 617.

The following figure is an example of the Default Option Tables report.

```
IMS HIGH PERFORMANCE LOAD                                PAGE:      1
5655-M26                                                11/01/2023 17.24.31

                "DEFAULT OPTION TABLES"

        SYSTEM DEFAULT: HPSCOPTS IN RGE410.SHPSLMD0
INSTALLATION DEFAULT: HPSCOPTI IN RGE410.SHPSLMD0

KEYWORD          SYSTEM DEFAULT      INSTALLATION DEFAULT
-----
CHKTRAIL         (YES,WARN)                        (YES,ERROR)
CHKUPDT          NO                                NO
CHKEMPTYUL       (YES,WARN,4)                       (YES,WARN,4)
COMPAUTH         NO                                NO
DECODEDBD       NO                                NO
EXTENT           120                               120
GDGBASE         NO                                YES
GDGLIMIT        10                                30
HPIO            N/A                               N/A
ILDSBLD         (YES,COND)                         (YES,COND)
ILEDATAC        N/A                               N/A
ILESTORC        N/A                               N/A
ITKBLOAD        *NO                               *NO
ITKBSRVR        *NO                               *NO
OADSPR          NO                                NO
PAD             X'00'                             X'00'
PARTINFO        YES                                YES
PARTINIT        NO                                NO
REPAIRILK       NO                                NO
SORT            NO                                NO
TWINSTAT        NO                                NO
WF1REC          YES                                YES
ZIIPMODE        NEVER                             NEVER
```

Figure 185. Default Option Tables report

## HPSIN Control Statements report

This report contains an echo back of the control statements you specified in the HPSIN data set. You can check the parameters used by the IPR Reload utility for this job step run.

The following figure shows an example of the HPSIN Control Statements report.



"HPSIN CONTROL STATEMENTS"

0.....1.....2.....3.....4.....5.....6.....7.....8  
1234567890123456789012345678901234567890123456789012345678901234567890  
BMSETDSG=(10000,11000,12000,13000,14000,15000,16000,17000,18000,19000)  
DBIOBUF=1  
DBRLBUF=11

"RUN TIME OPTIONS FOR THIS EXECUTION"

DBD : PHD00300 DBORG : PHDAM

OPTIONS FOR PROCESS CONTROL:

KEYWORD	VALUE
INPUT	DFSUINPT (FORMAT: *HD/*PHD)
USERHDR	N/A
DBRLBUF	11
BUFFERNO	N/A
DBIOBUF	1
RECNUM	N/A
HPIO	YES
ZIIPMODE	NEVER
OADSPR	NO
GDGBASE	NO
GDGLIMIT	N/A
COMPRESS	YES
COMPAUTH	NO
FRSPC	YES
PAD	X'00'
SEARCH	3
RAAFORMAT	YES
SEQERROR	ABEND
DATXEXIT	NO
PROGMON	0
EXTENT	52
SORT	NO
SORTIDAM	N/A
CHKUPDT	NO
CHKTRAIL	YES,WARN
CHKEMPTYUL	YES,WARN,4
BMSETDSG	(10000,11000,12000,13000,14000,15000,16000,17000,18000,19000)
WF1REC	N/A
WF1DSN	N/A
WF1UNIT	N/A
WF1VOL	N/A
WF1SPACE	N/A
WFPHLQ	N/A
WFPUNIT	N/A
WFPVOL	N/A
WFPVLCNT	N/A
WFPSPACE	N/A
DECODEDBD	NO
DBRECDIST	(100,200,300,400,500,600,700,800,900,1000,2000,3000,4000,5000,6000)
DBRECDIST	(7000,8000,9000,10000)
RAPCHAIN	NO

Figure 186. HPSIN Control Statements report for the IPR Reload utility (Part 1 of 2)

```

ILDSBLD      YES ,DSPR
ILEDATAC    N/A
ILESTORC    N/A

LPART       N/A
PARTINFO    YES
PARTINIT    NO
REPAIRILK   NO

RMBSEGSZ    NO

LAPIPCBNO   N/A
LAPIPCB     N/A
LAPIPDBD    N/A

PIPEOWAIT   N/A

ITKBSRVR    *NO
ITKBLOAD    N/A

```

OPTIONS FOR DIAGNOSIS:

```

KEYWORD      VALUE
-----
DBDSNAP      NO
TWINSTAT     NO
TRACE        N/A

```

Figure 187. HPSIN Control Statements report for the IPR Reload utility (Part 2 of 2)

The control statements you specified in the HPSIN data set are listed under the scale.

If a control statement turns out to be an error or needs a warning, an error message or a warning message is printed under the echo back of the control statement.

The "RUN TIME OPTIONS FOR THIS EXECUTION" part lists the options to be used for this utility run.

#### **DBD**

DBD name of the database.

#### **DBORG**

Database organization: HDAM, HIDAM, PHDAM, PHIDAM, HISAM, or SHISAM.

#### **OPTIONS FOR PROCESS CONTROL**

Options effective for process control.

#### **OPTIONS FOR DIAGNOSIS**

Options effective for diagnosis.

**Note:** The date and time shown in the report heading show when the reorganization reload was completed.

## **Decoded DBD report**

When the DECODEDBD control statement requests decoding a DBD, the resulting DBD source statements are printed in this report.

The following figure is an example of the Decoded DBD report.

```

*****
*
*                      DBHD0210
*
*                      DECODED BY IMS LMU REVERSAL
*
*****
*      DSNAME=TESTDS.0SFC7606.DBDLIB
*      VOL=DBT005
*      DBDGEN DATE 09/05/2023 TIME 17.31
*      DBD      NAME=DBHD0210,ACCESS=(HDAM,VSAM),
*              RMNAME=(DFSHDC40,5,1000,200),PASSWD=NO,
*              VERSION=          DATE 09/05/23 TIME 17.31
*
*****
*      DATASET GROUP NUMBER 1
*
*****
DSG001 DATASET DD1=DDHD0210,SIZE=(2048),SCAN=3
*****
*      SEGMENT NUMBER 1
*
*****
SEGMENT NAME=ROOTLEV1,PARENT=0,BYTES=20,RULES=(LLL,LAST),
PTR=(TWINBWD,,,,)
FIELD  NAME=(ROOTNO,SEQ,U),START=1,BYTES=8,TYPE=C
FIELD  NAME=(ROOTNAME),START=9,BYTES=12,TYPE=C
LCHILD NAME=(ROOTKEY,DBSX0210),PTR=INDX,RULES=LAST
XDFLD  NAME=XROOTNO,SEGMENT=,SRCH=(ROOTNO)
*****
*      SEGMENT NUMBER 2
*
*****
SEGMENT NAME=DEP1LEV2,PARENT=((ROOTLEV1,)),BYTES=21,
RULES=(LLL,LAST),PTR=(TWINBWD,,,,)
FIELD  NAME=(DEP1NO,SEQ,U),START=1,BYTES=8,TYPE=C
FIELD  NAME=(DEP1NAME),START=9,BYTES=13,TYPE=C
DBDGEN
FINISH
END

```

Figure 188. Decoded DBD report for the IPR Reload utility

## DBD Summary report

This report provides the information that is defined in the DBD.

The following figure is an example of the DBD Summary report for an HDAM database.

```

IMS HIGH PERFORMANCE LOAD
5655-M26
PAGE: 1
08/06/2023 09.30.07

"DBD SUMMARY"

DATABASE=DBHDV10 ORGANIZATION=HDAM ACCESS METHOD=ESDS DSGROUPS=3
RANDOMIZER=DFSHDC40 NBR OF RAPS=2 MAX RBN=5 MAX BYTES=

<- LENGTHS-> <- FLAGS-> <----- POINTER----->
PFX DATA TARGET TARGET
SEGMENT SC LVL DSG PARENT LEN LEN VCOXP---- TYPE SEGMENT DBDNAME
-----
ROOTLEV1 01 1 1 18 200 PTF ROOTLEV1
PCF DEP1LEV2
PCF DEP2LEV2
PCF DEP4LEV2
PTF DEP1LEV2
PTF DEP2LEV2
PCF DEP3LEV3
PTF DEP3LEV3
DEP4LEV2 05 2 3 ROOTLEV1 6 930 PTF DEP4LEV2

```

Figure 189. DBD Summary report for an HDAM database (IPR Reload utility)

The following figure is an example of the DBD Summary report for a HIDAM database.

"DBD SUMMARY"

DATABASE=DBHID01 ORGANIZATION=HIDAM ACCESS METHOD=OSAM DSGROUPS=3

PRIMARY INDEX=DBHID0X

SEGMENT	SC	LVL	DSG	PARENT	<-LENGTHS->		<-FLAGS->	<-----POINTER----->	
					PFX LEN	DATA LEN		TARGET SEGMENT	TARGET DBDNAME
ROOTLEV1	01	1	1		18	900		PTF	ROOTLEV1
								PCF	DEP1LEV2
								PCF	DEP2LEV2
								PCF	DEP4LEV2
DEP1LEV2	02	2	1	ROOTLEV1	6	900		PTF	DEP1LEV2
DEP2LEV2	03	2	2	ROOTLEV1	10	100		PTF	DEP2LEV2
								PCF	DEP3LEV3
DEP3LEV3	04	3	2	DEP2LEV2	6	100		PTF	DEP3LEV3
DEP4LEV2	05	2	3	ROOTLEV1	6	930		PTF	DEP4LEV2

Figure 190. DBD Summary report for a HIDAM database (IPR Reload utility)

The following figure is an example of the DBD Summary report for a PHIDAM database.

"DBD SUMMARY"

DATABASE=PHI00300 ORGANIZATION=PHIDAM ACCESS METHOD=OSAM DSGROUPS=3

SEGMENT	SC	LVL	DSG	PARENT	<-LENGTHS->		<-FLAGS->	<-----POINTER----->	
					PFX LEN	DATA LEN		TARGET SEGMENT	TARGET DBDNAME
ROOTLEV1	01	1	A		30	900		PTF	ROOTLEV1
								PTB	ROOTLEV1
								PCF	DEP1LEV2
								PCF	DEP2LEV2
								PCF	DEP4LEV2
DEP1LEV2	02	2	A	ROOTLEV1	18	900		PTF	DEP1LEV2
								PP	ROOTLEV1
DEP2LEV2	03	2	B	ROOTLEV1	22	20		PTF	DEP2LEV2
								PP	ROOTLEV1
								PCF	DEP3LEV3
DEP3LEV3	04	3	B	DEP2LEV2	18	30		PTF	DEP3LEV3
								PP	DEP2LEV2
DEP4LEV2	05	2	C	ROOTLEV1	18	930		PTF	DEP4LEV2
								PP	ROOTLEV1

Figure 191. DBD Summary report for a PHIDAM database (IPR Reload utility)

The following figure is an example of the DBD Summary report for a HISAM database.

"DBD SUMMARY"

DATABASE=DBHS0010 ORGANIZATION=HISAM ACCESS METHOD=KSDS

SEGMENT	SC	LVL	DSG	PARENT	<-LENGTHS->		<-FLAGS->	<-----POINTER----->	
					PFX LEN	DATA LEN		TARGET SEGMENT	TARGET DBDNAME
ROOTLEV1	01	1			2	200			
DEP1LEV2	02	2		ROOTLEV1	2	100	0		
DEP2LEV2	03	2		ROOTLEV1	2	200	C X		
DEP3LEV3	04	3		DEP2LEV2	2	200			
DEP4LEV2	05	2		ROOTLEV1	2	930	V		

Figure 192. DBD Summary report for a HISAM database (IPR Reload utility)

The meanings of the fields in the DBD Summary report are as follows:

**DATABASE**

Database name.

**ORGANIZATION**

The database organization of the processed database: HISAM, SHISAM, HDAM, HIDAM, PHDAM, or PHIDAM.

**ACCESS METHOD**

The method of getting access to the database: OSAM, ESDS, or KSDS.

**DSGROUPS**

Number of data set groups. For a HISAM or a SHISAM database, this field is not displayed.

**RANDOMIZER**

The randomizer name specified in the DBD parameter (RMNAME=). This field is displayed only for an HDAM database.

**NBR OF RAPS**

The number of root anchor points desired in each control interval or block in the root addressable area of an HDAM database that is specified in the DBD parameter (RMNAME=). This field is displayed only for an HDAM database.

**MAX RBN**

The maximum relative block number value that the user wants to allow a randomizing module to produce for this database that is specified in the DBD parameter (RMNAME=). This field is displayed only for an HDAM database.

**MAX BYTES**

The maximum number of bytes of a database record that can be stored into the root addressable area in a series of inserts unbroken by a call to another database record that is specified in the DBD parameter (RMNAME=). If this value is not specified in DBDGEN, a blank is displayed as the value. This field is displayed only for an HDAM database.

**PRIMARY INDEX**

The primary index name for the HIDAM database. This field is displayed only for a HIDAM database.

**SEGMENT**

The name of the segment type.

**SC**

The segment code. The value is printed as a hexadecimal number, including leading zeros.

**LVL**

The position of a segment in the hierarchy in relation to the root segment.

**DSG**

The data set group number of the segment type. For an HDAM or a HIDAM database, the value is printed as a numeral; for a HISAM or a SHISAM database, a blank; and for a HALDB, in alphabetic characters. In the case of the segment type of the virtual logical child, 0 is displayed.

**PARENT**

The name of the parent segment type.

**<-LENGTHS->**

**PFX LEN**

The length of the segment prefix in bytes. In the case of the segment type of the virtual logical child, this length is displayed as (VIRTUAL) over the PFX LEN field and the DATA LEN field.

**DATA LEN**

The maximum length in bytes of the data portion of a segment type that is defined in the DBD. In the case of the segment type of the virtual logical child, this length is displayed as (VIRTUAL) over the PFX LEN field and the DATA LEN field.

## <-FLAGS->

### **VCOXP----**

Segment definition information is indicated by flags. No flags are displayed in the case of the segment type of the virtual logical child. The meaning of the flags is as follows:

- V:**  
The variable-length segment.
- C:**  
The compress routine is specified.
- O:**  
The data length is an odd number of bytes.
- X:**  
COMPRTN=(,,max) is specified.
- P:**  
COMPRTN=(,,,PAD) is specified.

## <-----POINTER----->

### **TYPE**

The pointer types to be reserved in the prefix area of occurrences of the segment type. These types are not displayed in the case of the HISAM or SHISAM database or the segment type of the virtual logical child.

- CTR:**  
Counter field in prefix
- PTF:**  
Physical twin forward pointer
- PTB:**  
Physical twin backward pointer
- PP:**  
Physical parent pointer
- LTF:**  
Logical twin forward pointer
- LTB:**  
Logical twin backward pointer
- LP:**  
Logical parent pointer
- LCF:**  
Logical child first pointer
- LCL:**  
Logical child last pointer
- PCF:**  
Physical child first pointer
- PCL:**  
Physical child last pointer
- HF:**  
Hierarchic forward pointer
- HB:**  
Hierarchic backward pointer
- ELP:**  
Extended Pointer Set (EPS) for logical parent
- ELC:**  
Extended Pointer Set (EPS) for logical child

## TARGET SEGMENT

The name of the segment type indicated by the pointer displayed in the TYPE field. In the case of a hierarchic pointer, an asterisk (\*) is displayed.

## TARGET DBDNAME

When the name of the segment type displayed in the TARGET SEGMENT field is the name of the segment type of another database, the name of the database is displayed.

## Messages report

This report contains the messages issued by the IPR Reload utility.

Figure 193 on page 551 and Figure 194 on page 551 show examples of the Messages reports that contain messages HPSR0028I, HPSR0034I, and HPSR3634E.

```
IMS HIGH PERFORMANCE LOAD                                PAGE:      1
5655-M26                                                08/27/2023 20.24.15

"MESSAGES"

HPSR0034I A SEQUENCE FIELD IS NOT UNIQUE SEGMENT=ROOTLEV1 FIELD=ROOTNO
HPSR0028I          2 DB RECORDS PROCESSED
HPSR0034I A SEQUENCE FIELD IS NOT UNIQUE SEGMENT=ROOTLEV1 FIELD=ROOTNO
HPSR0028I          3 DB RECORDS PROCESSED
HPSR0034I A SEQUENCE FIELD IS NOT UNIQUE SEGMENT=ROOTLEV1 FIELD=ROOTNO
HPSR0028I          4 DB RECORDS PROCESSED
HPSR0034I A SEQUENCE FIELD IS NOT UNIQUE SEGMENT=ROOTLEV1 FIELD=ROOTNO
HPSR0028I          5 DB RECORDS PROCESSED
HPSR0034I A SEQUENCE FIELD IS NOT UNIQUE SEGMENT=ROOTLEV1 FIELD=ROOTNO
HPSR0028I          6 DB RECORDS PROCESSED
HPSR0034I A SEQUENCE FIELD IS NOT UNIQUE SEGMENT=ROOTLEV1 FIELD=ROOTNO
HPSR0028I          7 DB RECORDS PROCESSED
HPSR0034I A SEQUENCE FIELD IS NOT UNIQUE SEGMENT=ROOTLEV1 FIELD=ROOTNO
HPSR0028I          8 DB RECORDS PROCESSED
HPSR0034I A SEQUENCE FIELD IS NOT UNIQUE SEGMENT=ROOTLEV1 FIELD=ROOTNO
HPSR0028I          9 DB RECORDS PROCESSED
HPSR0034I A SEQUENCE FIELD IS NOT UNIQUE SEGMENT=ROOTLEV1 FIELD=ROOTNO
HPSR0028I         10 DB RECORDS PROCESSED
HPSR0034I A SEQUENCE FIELD IS NOT UNIQUE SEGMENT=ROOTLEV1 FIELD=ROOTNO
HPSR0028I         11 DB RECORDS PROCESSED
HPSR0034I A SEQUENCE FIELD IS NOT UNIQUE SEGMENT=ROOTLEV1 FIELD=ROOTNO
HPSR0028I         12 DB RECORDS PROCESSED
HPSR0034I A SEQUENCE FIELD IS NOT UNIQUE SEGMENT=ROOTLEV1 FIELD=ROOTNO
HPSR0028I         13 DB RECORDS PROCESSED
HPSR0034I A SEQUENCE FIELD IS NOT UNIQUE SEGMENT=ROOTLEV1 FIELD=ROOTNO
HPSR0028I         14 DB RECORDS PROCESSED
HPSR0034I A SEQUENCE FIELD IS NOT UNIQUE SEGMENT=ROOTLEV1 FIELD=ROOTNO
HPSR0028I         15 DB RECORDS PROCESSED
HPSR0034I A SEQUENCE FIELD IS NOT UNIQUE SEGMENT=ROOTLEV1 FIELD=ROOTNO
HPSR0028I         16 DB RECORDS PROCESSED
HPSR0034I A SEQUENCE FIELD IS NOT UNIQUE SEGMENT=ROOTLEV1 FIELD=ROOTNO
HPSR0028I         17 DB RECORDS PROCESSED
HPSR0034I A SEQUENCE FIELD IS NOT UNIQUE SEGMENT=ROOTLEV1 FIELD=ROOTNO
HPSR0028I         18 DB RECORDS PROCESSED
HPSR0034I A SEQUENCE FIELD IS NOT UNIQUE SEGMENT=ROOTLEV1 FIELD=ROOTNO
HPSR0028I         19 DB RECORDS PROCESSED
HPSR0034I A SEQUENCE FIELD IS NOT UNIQUE SEGMENT=ROOTLEV1 FIELD=ROOTNO
HPSR0028I         20 DB RECORDS PROCESSED
```

Figure 193. Messages report for HPSR0028I and HPSR0034I

```
IMS HIGH PERFORMANCE LOAD                                PAGE:      1
5655-M26                                                08/24/2023 21.32.09

"MESSAGES"

HPSR3634E A ROOT SEGMENT OF HIDAM/PHIDAM IS OUT OF SEQUENCE
DBD=HIVSDB10 SEGMENT=ROOTLEV1 FIELD=ROOTKEY1

000000000001
FFFFFFFFFFFF
000000000001
```

Figure 194. Messages report for HPSR3634E

## HALDB Partitions Processed report

This report contains information about processed partitions.

The following figure is an example of the HALDB Partitions Processed report. This report is written when a HALDB is processed.

```
IMS HIGH PERFORMANCE LOAD                                PAGE:      1
5655-M26                                                08/05/2023 10.32.19

                "HALDB PARTITIONS PROCESSED"

DBDNAME..... PHD00300
NUMBER OF PARTITIONS DEFINED..... 3
NUMBER OF PARTITIONS PROCESSED... 3
PARTITION SELECTION EXIT..... N/A

LIST OF PARTITIONS RELOADED

  PHD003A  PHD003B  PHD003C

LIST OF PARTITIONS INITIALIZED
```

Figure 195. HALDB Partitions Processed report (IPR Reload utility)

The meanings of the fields in the HALDB Partitions Processed report are as follows:

### **DBDNAME**

The DBD name of the database.

### **NUMBER OF PARTITIONS DEFINED**

The number of partitions that are defined in the HALDB.

### **NUMBER OF PARTITIONS PROCESSED**

The number of partitions that are processed in the HALDB.

### **PARTITION SELECTION EXIT**

The name of the partition selection exit, if used. When the high key selection is used, this field shows N/A.

### **LIST OF PARTITIONS RELOADED**

The list of names of the partitions that were reloaded in the HALDB.

### **LIST OF PARTITIONS INITIALIZED**

The list of names of the partitions that were initialized in the HALDB.

## Segment Count Summary report

This report provides the input segment occurrences and the output segment occurrences of each segment type.

The following figure shows an example of the Segment Count Summary report.

The report consists of three parts separated by the following headers:

- SEGMENT COUNTS IN WHOLE DB
- SEGMENT COUNTS IN HDAM OVERFLOW AREA
- SEGMENT COUNTS IN KEY SEQUENCE ERROR

SEGMENT COUNTS IN KEY SEQUENCE ERROR is printed only when SEQERROR=SAVE or SEQERROR=ACCEPT is specified. It shows, for each segment type, the information about segments that have a key sequence error.



"SEGMENT COUNT SUMMARY"

DBNAME = DBHDV10 DS GROUPS = 2 ORG = HDAM ACCESS METHOD = ESDS

\*\*\* SEGMENT COUNT IN WHOLE DB \*\*\*

SEGNAME	LVL	DSG	PARENT	READ	RELOADED	DELETED BY RANDOMIZER	DELETED BY USER EXIT
ROOTLEV1	01	01		20	20	0	N/A
DEP1LEV2	02	01	ROOTLEV1	15,980	15,980	0	N/A
DEP2LEV2	02	02	ROOTLEV1	100	100	0	N/A
TOTAL				16,100	16,100	0	N/A

\*\*\* SEGMENT COUNT IN HDAM OVERFLOW AREA \*\*\*

SEGNAME	OCCURRENCES	PERCENTAGE
ROOTLEV1	19	95.0
DEP1LEV2	15,973	100.0
DEP2LEV2	0	0.0
TOTAL	15,992	

\*\*\* SEGMENT COUNT IN KEY SEQUENCE ERROR \*\*\*

SEGNAME	KEY SEQERROR OCCURRENCES	ERROR PERCENTAGE	OUTPUT IN OCCURRENCES	SEQERROR DS PERCENTAGE
ROOTLEV1	19	95.0	N/A	N/A
DEP1LEV2	0	0.0	N/A	N/A
DEP2LEV2	0	0.0	N/A	N/A
TOTAL	19	0.1	N/A	N/A

Figure 196. Segment Count Summary report (IPR Reload utility)

Figure 196 on page 553 shows an example of the Segment Count Summary report for an HDAM database.

This report provides the balance between input and output segment occurrences of each segment type. All values in the report are in decimal, and each line describes one segment type in the database.

This topic describes each item of the Segment Count Summary report. The items are common to all HDAM, HIDAM, HISAM, and SHISAM databases, except for the overflow area statistics items that are available for HDAM, PHDAM, and HISAM.

**SEGMENT COUNT IN WHOLE DB**

The information about segment counts in the entire database.

**SEGNAME**

The name of the segment.

**LVL**

The hierarchical level of the segment.

**DSG**

The data set group number.

**PARENT**

The name of the parent segment.

**READ**

The number of segment occurrences that are read by the Reload task for this database.

**RELOADED**

The number of segment occurrences that are reloaded by the Reload task for this database.

**DELETED BY RANDOMIZER**

The number of segment occurrences that are deleted due to a return code 4 from the HDAM or PHDAM randomizer.

**DELETED BY USER EXIT**

The number of deleted segment occurrences due to a return code 8 or 12 from the user exit routine.

**SEGMENT COUNT IN HDAM OVERFLOW AREA**

The information about segment counts in the HDAM, PHDAM, or HISAM overflow area. The segment count in the HDAM, PHDAM, or HISAM overflow area contains the following items:

**OCCURRENCES**

The number of occurrences of the segment.

**PERCENTAGE**

Of all occurrences of this segment type, the percentage of the occurrences in the overflow.

**SEGMENT COUNT IN KEY SEQUENCE ERROR**

The information about the segments that caused a key sequence error. This part is printed only when SEQERROR=SAVE or SEQERROR=ACCEPT is specified.

**KEY SEQUENCE ERROR OCCURRENCES**

The number of occurrences of key sequence errors for this segment type.

**KEY SEQUENCE ERROR PERCENTAGE**

Of all occurrences of this segment type, the percentage of the occurrences of key sequence errors.

**OUTPUT IN SEQERROR DS OCCURRENCES**

The number of segment occurrences saved in the SEQERROR data set for this segment type.

**OUTPUT IN SEQERROR DS PERCENTAGE**

Of all occurrences of this segment type, the percentage of segment occurrences saved in the SEQERROR data set.

## Segment Statistics report

This report contains information about segments in databases by segment type.

- This report does not show segment types of a virtual logical child.
- For HALDBs, this report is created for each partition.
- For HDAM, PHDAM, and HISAM databases, information about segments in the overflow area or the overflow data set is shown by segment type under the Segment In Overflow Statistics section.

In addition to the basic information about segments, this report has the following section.

**Variable Length Segment Statistics section**

When there is any variable-length segment in a database, this section is produced as a part of the Segment Statistics report. When there is no variable-length segment, this section is not printed.

This section shows—for each segment type—information about variable-length segments (including compressed fixed-length segments).

This section does not show segment types of virtual logical child or fixed-length segments.

**Twin Segment Statistics section**

When TWINSTAT=YES is specified, this section is produced as a part of the Segment Statistics report. This section is not printed for HISAM and SHISAM databases.

The following figures show examples of Segment Statistics reports.

The following figure shows a case of a fixed-length segment in an HDAM database.

"SEGMENT STATISTICS"

SEGMENT STATISTICS

SEGMENT	TOTAL NBR OF OCCURRENCES	<-----AVG OCCURRENCES-----> PER PARENT	PER RECORD	AVG SEGM LENGTH	<--CONTRIBUTION TO DB RECORD SIZE--> PCT	CUM SIZE
ROOTLEV1	5	1.0	1.0	218	0.0%	218
DEP1LEV2	5	1.0	1.0	106	0.0%	324
DEP2LEV2	3,000	600.0	600.0	210	15.5%	126,324
DEP3LEV3	3,000	1.0	600.0	206	15.2%	249,924
DEP4LEV2	3,000	600.0	600.0	936	69.2%	811,524

SEGMENT IN OVERFLOW STATISTICS

SEGMENT	<-----OVERFLOW-----> NUMBER	PCT
ROOTLEV1	0	0.0%
DEP1LEV2	0	0.0%
DEP2LEV2	N/A	N/A
DEP3LEV3	N/A	N/A
DEP4LEV2	N/A	N/A

TOTAL SEGMENTS = 9,010

Figure 197. Segment Statistics report for an HDAM database (IPR Reload utility)

The following figure shows a case in which the following conditions are met in a PHIDAM database:

- There is a variable-length segment.
- There is a segment type for which a Segment Edit/Compression routine is specified.
- COMPRESS=NO is specified.
- TWINSTAT=YES is specified.

"SEGMENT STATISTICS"

--- PARTITION=PHI001A ---

SEGMENT STATISTICS

SEGMENT	TOTAL NBR OF OCCURRENCES	<-----AVG OCCURRENCES-----> PER PARENT	PER RECORD	AVG SEGM LENGTH	<-- CONTRIBUTION TO DB RECORD SIZE--> PCT	CUM SIZE
ROOT1LV1	2	1.0	1.0	50	2.3%	50
DEP11LV2	7	3.5	3.5	43	6.9%	201
DEP21LV2	10	5.0	5.0	42	9.6%	411
DEP31LV3	3	0.3	1.5	45	3.1%	478
DEP41LV2	8	4.0	4.0	53	9.7%	690
DEP51LV3	9	1.1	4.5	151	31.3%	1,371
DEP61LV3	16	2.0	8.0	101	37.0%	2,177

TOTAL SEGMENTS = 55

ILDS RECORDS = 2

<<< VARIABLE LENGTH SEGMENT STATISTICS >>>

SEGMENT	<-----LENGTHS----->				<-----SEGMENT COUNT----->	<-COMPRESSION-->	
	MIN	MAX	PFX	DATA	<MIN	=>MIN	FACTOR NAME
DEP31LV3	4	40	22	23	0	3 +	13.4% DFSCMPX0
DEP41LV2	50	100	30	23	8	0 +	42.7% DFSCMPX0
DEP51LV3	100	200	18	133	0	9	
DEP61LV3	70	140	22	79	0	16	

TWIN SEGMENT STATISTICS

SEGMENT	NUMBER OF CHAINS	MAX CHAIN LENGTH	AVG CHAIN LENGTH
ROOT1LV1	N/A		
DEP11LV2	1	6	6.0
DEP21LV2	1	9	9.0
DEP31LV3	0	0	0.0
DEP41LV2	2	6	4.0
DEP51LV3	3	3	2.3
DEP61LV3	3	8	4.7

Figure 198. Segment Statistics report for a PHIDAM database (IPR Reload utility)

The following figure shows a case in which the following conditions are met in a HISAM database:

- There is a variable-length segment.
- There is a segment type for which a Segment Edit/Compression routine is specified as the segment type of the fixed-length segment.
- COMPRESS=YES is specified.

"SEGMENT STATISTICS"

SEGMENT STATISTICS

SEGMENT	TOTAL NBR OF OCCURRENCES	<-----AVG OCCURRENCES-----> PER PARENT	PER RECORD	AVG SEGM LENGTH	<--CONTRIBUTION TO DB RECORD SIZE--> PCT	CUM SIZE
ROOTLEV1	10	1.0	1.0	22	5.5%	22
DEP1LEV2	10	1.0	1.0	23	5.7%	45
DEP2LEV2	11	1.1	1.1	25	6.8%	73
DEP3LEV3	9	0.8	0.9	32	7.1%	101
DEP4LEV2	11	1.1	1.1	79	21.6%	189
DEP5LEV3	9	0.8	0.9	121	27.0%	297
DEP6LEV3	11	1.0	1.1	96	26.2%	403

SEGMENT IN OVERFLOW STATISTICS

SEGMENT	<-----OVERFLOW-----> NUMBER	PCT
ROOTLEV1	N/A	N/A
DEP1LEV2	0	0.0%
DEP2LEV2	0	0.0%
DEP3LEV3	0	0.0%
DEP4LEV2	2	18.2%
DEP5LEV3	4	44.4%
DEP6LEV3	8	72.7%

TOTAL SEGMENTS = 71

<<< VARIABLE LENGTH SEGMENT STATISTICS >>>

SEGMENT	<-----LENGTHS----->				<-----SEGMENT COUNT----->		<-COMPRESSION-->	
	MIN	MAX	PFX	DATA	<MIN	=>MIN	FACTOR	NAME
DEP2LEV2	4	40	2	23	0	11	13.6%	DFSCMPX0
DEP4LEV2	50	100	2	77	0	11		
DEP5LEV3	100	200	2	119	4	5		
DEP6LEV3	70	140	2	94	0	11		

Figure 199. Segment Statistics report for a HISAM database (IPR Reload utility)

The meanings of the fields in the Segment Statistics report are as follows:

**PARTITION**

The partition name. This field is printed only for a HALDB.

**SEGMENT STATISTICS**

**SEGMENT**

The name of the segment type.

**TOTAL NBR OF OCCURRENCES**

The total number of occurrences by segment type.

**<-----AVG OCCURRENCES----->**

**PER PARENT**

The average number of occurrences of this segment for each occurrence of its parent segment. This is the average twin chain length.

**PER RECORD**

The average number of occurrences of this segment type per database record.

**AVG SEGM LENGTH**

The average length (in bytes) of occurrences by segment type. The length of an occurrence is the sum total of the prefix length and the data length of a segment. When a segment is a variable-length segment (or a compressed fixed-length segment), the average value of the LL fields is used.

## <--CONTRIBUTION TO DB RECORD SIZE-->

### **PCT**

The percentage of the total number of bytes of occurrences of the segment type in the bytes of one database record. This value is shown for each segment type.

### **CUM SIZE**

The cumulative average record size (in bytes) up to the layer of the segment type. This value of the last segment type becomes the logical average database record size excluding the bytes padded by IMS.

## **SEGMENT IN OVERFLOW STATISTICS**

### **SEGMENT**

The name of the segment type.

### <-----OVERFLOW----->

#### **NUMBER**

For an HDAM or a PHDAM database, this means the number of segments in the overflow area, and N/A is printed for the segment types in the second and subsequent data set groups.

For a HISAM database, this means the number of segments in the overflow data set, and N/A is printed for the root segment type.

#### **PCT**

The percentage of segment occurrences in the overflow area or in the overflow data set, within all occurrences in the relevant database or partition. PCT is reported for each segment type.

### **TOTAL SEGMENTS**

The total number of occurrences of all segment types.

### **ILDS RECORDS**

The number of ILE records in ILDS for this partition.

## <<< VARIABLE LENGTH SEGMENT STATISTICS >>>

### **SEGMENT**

The name of the segment type.

### <-----LENGTHS----->

#### **MIN**

The minimum segment length (in bytes) by segment type. For details, see [Table 81 on page 559](#).

#### **MAX**

The maximum segment length (in bytes) by segment type. For details, see [Table 81 on page 559](#).

#### **PFX**

The prefix length (in bytes) by segment type.

#### **DATA**

The data length (in bytes) by segment type.

The following table shows the possible values for fields MIN and MAX in the Segment Statistics report for a HISAM database.

Table 81. Possible values of MIN and MAX

MIN or MAX	Variable-length segment	Compressed fixed-length segment with no PAD value specified		Compressed fixed-length segment with a PAD value specified	
		MAX value < 10	10 < MAX value	PAD value < value of BYTES= + 10	Value of BYTES= + 10 < PAD value
MIN	<i>minbytes</i> specified in BYTES=.	4		4	
MAX	<i>maxbytes</i> specified in BYTES=.	Length specified in BYTES= + 10.	Length specified in BYTES= + MAX value.	Length specified in BYTES= + 10.	PAD value

**Note:** BYTES=: BYTES= keyword in the SEGM statement of DBDGEN. MAX value: MAX value of the COMPRTN= keyword in the SEGM statement of DBDGEN. PAD value: PAD value of the COMPRTN= keyword in the SEGM statement of DBDGEN.

<-----SEGMENT COUNT----->

<MIN

The number of segments shorter than the minimum segment length of each segment type.

=>MIN

The number of segments longer than the minimum segment length of each segment type.

<-COMPRESSION-->

FACTOR

A compression ratio is shown when the segment type is compressed segment. The factor is calculated by the following formula:

$$\frac{(\text{AL of decompressed segment} + \text{PL}) - (\text{AL of compressed segment} + \text{PL})}{(\text{AL of decompressed segment} + \text{PL})} \times 100$$

where: AL: average length PL: prefix length

For a variable-length segment that is not compressed, a blank is printed.

If COMPRESS=NO is specified when the Segment Edit/Compression routine is specified, then N/A is printed.

NAME

When the segment type is a compressed segment, the name of the Segment Edit/Compression routine specified in DBD is printed.

For a variable-length segment that is not compressed, a blank is printed.

**TWIN SEGMENT STATISTICS**

The twin chain statistics section provides statistics about the twin chained segments:

**SEGMENT**

The name of the segment.

**NUMBER OF CHAINS**

The total number of twin chain occurrences for the segment type.

N/A is shown if a twin pointer is not defined for the segment.

**MAX CHAIN LENGTH**

The maximum length of twin chains.

**AVG CHAIN LENGTH**

The average length of twin chains.

## HDAM Root Addressable Area Statistics report

This report contains information about root segments and root anchor points in an HDAM or a PHDAM database.

This report contains information about a randomizing module and randomizing parameters together with the three sections described as follows. For PHDAM database, this report is created for each partition.

### **Key Indicators for Quality of Randomizing section**

This section provides information for checking the efficiency of the randomizing module. For the method of checking the efficiency of the randomizing module, see [Chapter 46, "Database tuning guide,"](#) on page 629.

### **Distribution of HDAM RAP Chain Lengths section**

This section provides a distribution of root segments that are chained by one root anchor point.

This section is not generated by default. It is printed only when RAPCHAIN=YES is specified and when the input database records are in the order of BBBR. If you change the randomizing module and the randomizing parameters, database records might not be in the order of BBBR, and therefore, you need to load the database records after you have sorted them by using Physical Sequence Sort for Reload (PSSR) of IMS HP Load. For more information about Physical Sequence Sort for Reload (PSSR) of IMS HP Load, see the *IMS High Performance Load User's Guide*.

### **HDAM Root Placement section**

This section provides a distribution of the placement of root segments.

The value specified on the SEARCH control statement is used as the number of blocks printed both before and after the home block.

If SEARCH=0 or SEARCH=-0 is specified, this section is not generated.

The following figure shows an example of the HDAM Root Addressable Area Statistics report.



"HDAM ROOT ADDRESSABLE AREA STATISTICS"

RANDOMIZER=DFSHDC40 NBR OF RAPS=2 MAX RBN=5 MAX BYTES=

<<< KEY INDICATORS FOR QUALITY OF RANDOMIZING >>>

NUMBER OF ROOT SEGMENTS.....	5
NUMBER OF ROOT SYNONYM CHAINS.....	1
NUMBER OF ROOTS PER SYNONYM CHAIN.....	2.0
NUMBER OF ROOTS NOT ON A SYNONYM CHAIN.....	3
NUMBER OF ROOTS ON A SYNONYM CHAIN.....	2
NUMBER OF ROOTS IN LONGEST SYNONYM CHAIN.....	2
NUMBER OF ROOTS NOT IN THE RANDOMIZED BLOCK...	0
NUMBER OF ROOTS PER ROOT ANCHOR POINT.....	1.3
NUMBER OF ROOT ANCHOR POINTS PER ROOT.....	2.0
NUMBER OF ROOT ANCHOR POINTS USED.....	4
NUMBER OF ROOT ANCHOR POINTS NOT USED.....	6
PERCENT OF ROOT ANCHOR POINTS USED.....	40.0%

<<< DISTRIBUTION OF HDAM RAP CHAIN LENGTHS >>>

CHAIN LENGTH	NBR OF CHAINS	NBR OF ROOTS	PCT OF TOTAL ROOTS	CUM OF TOTAL ROOTS
1	3	3	60.0%	60.0%
2	1	2	40.0%	100.0%
3	0	0	0.0%	100.0%
4	0	0	0.0%	100.0%
5	0	0	0.0%	100.0%
6	0	0	0.0%	100.0%
7	0	0	0.0%	100.0%
8	0	0	0.0%	100.0%
9	0	0	0.0%	100.0%
10	0	0	0.0%	100.0%
11+	0	0	0.0%	100.0%

"HDAM ROOT ADDRESSABLE AREA STATISTICS"

<<< HDAM ROOT PLACEMENT >>>

LOCATION	PCT	QUANTITY
- 3	0.0%	0
- 2	0.0%	0
- 1	0.0%	0
HOME BLOCK	100.0%	5
+ 1	0.0%	0
+ 2	0.0%	0
+ 3	0.0%	0

Figure 200. HDAM Root Addressable Area Statistics report for an HDAM (IPR Reload utility)

The meanings of the fields in the HDAM Root Addressable Area Statistics report are as follows:

**PARTITION**

The partition name. This field is printed only for a PHDAM database.

**RANDOMIZER**

The randomizer name specified in the DBD parameter (RMNAME=). For a PHDAM database, the randomizer name for each partition set in the DBD parameter or the HALDB partition definition.

**NBR OF RAPS**

The number of root anchor points desired in each control interval or block in the root addressable area of an HDAM database that is specified in the DBD parameter (RMNAME=).

For a PHDAM database, the value for each partition set in the DBD parameter or the HALDB partition definition.

**MAX RBN**

The maximum relative block number value that you want to allow a randomizing module to produce for this database and that is specified in the DBD parameter (RMNAME=).

For a PHDAM database, the value for each partition set in the DBD parameter or the HALDB partition definition.

**MAX BYTES**

The maximum number of bytes of a database record that can be stored into the root addressable area in a series of inserts unbroken by a call to another database record and that is specified in the DBD parameter (RMNAME=).

When this value is not specified in DBDGEN, a blank is printed as the value.

For a PHDAM database, the value for each partition set in the DBD parameter or the HALDB partition definition.

**<<< KEY INDICATORS FOR QUALITY OF RANDOMIZING >>>****NUMBER OF ROOT SEGMENTS**

The number of root segments in a database.

**NUMBER OF ROOT SYNONYM CHAINS**

The number of root anchor points to which two or more root segments are chained.

**NUMBER OF ROOTS PER SYNONYM CHAIN**

When the root anchor points to which two or more root segments are chained are considered, the average number of root segments chained.

**NUMBER OF ROOTS NOT ON A SYNONYM CHAIN**

The number of root segments pointed at by root anchor segments that point at only one root segment.

**NUMBER OF ROOTS ON A SYNONYM CHAIN**

The number of root segments chained by the root anchor points to which two or more root segments are chained.

**NUMBER OF ROOTS IN LONGEST SYNONYM CHAIN**

Of the root anchor points to which two or more root segments are chained, the number of root segments chained by the root anchor point to which the most root segments are chained.

If the input database records are not in the order of BBR, this field shows N/A.

**NUMBER OF ROOTS NOT IN THE RANDOMIZED BLOCK**

The number of root segments that did not fit on the home block. The home block is the block that the root segment must be placed in, based on the randomizing routine.

If SEARCH=0 or SEARCH=-0 is specified, this field shows N/A.

**NUMBER OF ROOTS PER ROOT ANCHOR POINT**

The average number of root segments chained by a root anchor point used (a root anchor point to which at least one root segment is chained).

**NUMBER OF ROOT ANCHOR POINTS PER ROOT**

The average number of root anchor points for each root segment.

**NUMBER OF ROOT ANCHOR POINTS USED**

The number of root anchor points used (to which at least one root segment is chained).

**NUMBER OF ROOT ANCHOR POINTS NOT USED**

The number of root anchor points not used (to which not a single root segment is chained).

**PERCENT OF ROOT ANCHOR POINTS USED**

The percentage of the number of root anchor points used within all root anchor points. (The percentage of use of root anchor points)

**<<< DISTRIBUTION OF HDAM RAP CHAIN LENGTHS >>>**

**CHAIN LENGTH**

The range of the number of root segments chained by a root anchor point. (If  $n$  root segments are randomized to a root anchor point, the root anchor point is said to have  $n-1$  synonyms and have a chain length of  $n$ .)

The range is 1, 2, 3, 4, 5, 6, 7, 8, 9, 10, and 11+ (11+ means 11 and over).

**NUMBER OF CHAINS**

The number of root anchor points by CHAIN LENGTH.

**NUMBER OF ROOTS**

The number of root segments by CHAIN LENGTH.

**PCT OF TOTAL ROOTS**

For each CHAIN LENGTH, the percentage of the number of root segments on the CHAIN LENGTH within all root segments.

**CUM OF TOTAL ROOTS**

The cumulative total of PCT OF TOTAL ROOTS up to the CHAIN LENGTH.

**<<< HDAM ROOT PLACEMENT >>>****LOCATION**

The range of the relative locations from the home block for root segments. The home block is the block that the root segment should be placed in, based on the randomizing routine. This range uses the value specified in the SEARCH control statement.

The values printed in LOCATION—other than the range of values that the IPR Reload utility searches specified by the SEARCH control statement (see [“SEARCH control statement”](#) on page 527)—are:

**HOME BLOCK**

The home bloc

**OVERFLOW**

The overflow area

**PCT**

For each LOCATION, the percentage of the number of root segments in the LOCATION within all root segments.

**QUANTITY**

For each LOCATION, the number of root segments in the LOCATION.

**Distribution of Database Record Sizes report**

This report contains the distribution of the lengths of database records in databases other than SHISAM.

The following figure is an example of the Distribution of Database Record Sizes report.

"DISTRIBUTION OF DATABASE RECORD SIZES"

RANGE	QUANTITY	PCT	CUM PCT
- 100	0	0.0%	0.0%
101 - 200	2	16.7%	16.7%
201 - 300	2	16.7%	33.3%
301 - 400	1	8.3%	41.7%
401 - 500	2	16.7%	58.3%
501 - 600	0	0.0%	58.3%
601 - 700	1	8.3%	66.7%
701 - 800	2	16.7%	83.3%
801 - 900	1	8.3%	91.7%
901 - 1000	0	0.0%	91.7%
1001 - 2000	1	8.3%	100.0%
2001 - 3000	0	0.0%	100.0%
3001 - 4000	0	0.0%	100.0%
4001 - 5000	0	0.0%	100.0%
5001 - 6000	0	0.0%	100.0%
6001 - 7000	0	0.0%	100.0%
7001 - 8000	0	0.0%	100.0%
8001 - 9000	0	0.0%	100.0%
9001 - 10000	0	0.0%	100.0%
10001 -	0	0.0%	100.0%
AVERAGE DATABASE RECORD SIZE =		519	
SHORTEST DATABASE RECORD SIZE =		102	
LONGEST DATABASE RECORD SIZE =		1,096	

Figure 201. Distribution of Database Record Sizes report (IPR Reload utility)

The range of database record sizes in bytes is specified by the DBRECDIST control statement. If DBRECDIST=0 is specified, this report is not generated. For HALDBs, this report is generated for each partition.

The meanings of the fields in the Distribution of Database Record Sizes report are as follows:

**PARTITION**

The partition name. This field is printed only for a HALDB.

**RANGE**

The range of database record sizes in bytes.

**QUANTITY**

For each range, the number of database records stored in the range. The database record size used in each range includes the size of the prefix portion and the size of the data portion of each segment.

For variable-length segments (including compressed fixed-length segments), the size of the data portion is calculated as a length that can be actually stored in a database record, including the bytes padded by IMS.

The size of the virtual LPCK part is not included.

**PCT**

For each range, the percentage of the number of database records stored within the range in all database records.

**CUM PCT**

The cumulative total of PCT from the smallest RANGE to a particular RANGE.

**AVERAGE DATABASE RECORD SIZE**

The physical average size of database records including the bytes padded by IMS.

**SHORTEST DATABASE RECORD SIZE**

The physical size of the shortest database record including the bytes padded by IMS.

**LONGEST DATABASE RECORD SIZE**

The physical size of the longest database record including the bytes padded by IMS.

## HISAM Statistics report

This report contains the number of logical records in a HISAM database or the chaining information of segments to the overflow data set. It is generated only for a HISAM database.

The following figure is an example of the HISAM Statistics report.

```
IMS HIGH PERFORMANCE LOAD                                PAGE:      1
5655-M26                                                08/04/2023 13.09.09

                "HISAM STATISTICS"

PRIMARY DD = DDHS0010

NUMBER OF LOGICAL RECORDS.....                          5
NUMBER OF RECORDS WITH OVERFLOW CHAINS.....              5
NUMBER OF RECORDS WITH NO OVERFLOW CHAINS...              0
MAX NUMBER OF OVERFLOW CHAINS.....                        1
MIN NUMBER OF OVERFLOW CHAINS.....                        1
AVERAGE NUMBER OF OVERFLOW CHAINS.....                   1.0

OVERFLOW DD = DDH00010

NUMBER OF LOGICAL RECORDS.....                          5
```

Figure 202. HISAM Statistics report (IPR Reload utility)

The meanings of the fields in the HISAM Statistics report are as follows:

### PRIMARY DD

The ddname of the primary data set in a HISAM database that is specified in the DBD parameter (the DD1= keyword of the DATASET control statement).

### NUMBER OF LOGICAL RECORDS

The number of logical records that contain segments in the primary data set.

### NUMBER OF RECORDS WITH OVERFLOW CHAINS

The number of logical records that have pointers to the overflow data set.

### NUMBER OF RECORDS WITH NO OVERFLOW CHAINS

The number of logical records that do not have pointers to the overflow data set.

### MAX NUMBER OF OVERFLOW CHAINS

The maximum number of VSAM ESDS roots chained off from one VSAM KSDS root.

### MIN NUMBER OF OVERFLOW CHAINS

The minimum nonzero number of VSAM ESDS roots chained off from one VSAM KSDS root.

### AVERAGE NUMBER OF OVERFLOW CHAINS

Average number of VSAM ESDS roots chained off from one VSAM KSDS root (of those with chains).

### OVERFLOW DD

The ddname of the overflow data set in a HISAM database that is specified in the DBD parameter (the OVFLW= keyword in the DATASET control statement). If an overflow data set is not specified in the DBD, this item is not printed.

### NUMBER OF LOGICAL RECORDS

The number of logical records that contain segments in the overflow data set. If an overflow data set is not specified in the DBD, this item is not printed.

## Data Set Statistics report

This report provides definition information and statistics information about database data sets.

For an HDAM, a HIDAM, a PHDAM, or a PHIDAM database, it contains the following section.

For a HALDB, this report is generated for each partition. Information about the data set of the primary index and the ILDS data set is not shown in the report for a HALDB.

### Distribution of Free Space section

For an HDAM, a HIDAM, a PHDAM, or a PHIDAM database, this section shows the distribution of free space in database data sets. The following figure shows the Data Set Statistics with the Distribution of Free Space section for an HDAM.

IMS HIGH PERFORMANCE LOAD  
5655-M26

PAGE: 1  
08/06/2023 09.30.10

#### "DATA SET STATISTICS"

DSG	DDNAME	BLOCK SIZE	RECORD SIZE	DATA SET NAME
1	DDHDV10	4,096	4,089	TEMPDS.ORFF1102.DBHDV10.DDHDV10.RL
2	DDHDV11	512	505	TEMPDS.ORFF1102.DBHDV10.DDHDV11.RL
3	DDHDV12	28,672	28,665	TEMPDS.ORFF1102.DBHDV10.DDHDV12.RL

DSG	DDNAME	FBFF	FSPF	FSPF BYTES	SMALL SEGSZ	LARGE SEGSZ	TOTAL BLOCKS
1	DDHDV10	0	0	0	106	218	5
2	DDHDV11	0	0	0	206	210	3,001
3	DDHDV12	0	0	0	936	936	101

NUMBER OF BLOCKS IN OVERFLOW = 0

#### <<< DISTRIBUTION OF FREE SPACE >>>

DSG	FREE SPACE RANGE	NUMBER OF BLOCKS	PCT OF TOTAL BLKS	<-----CUMULATIVE----->		AVG SIZE OF FREE SPACE
				NUMBER OF BLOCKS	PCT OF TOTAL BLKS	
1	218 - 4,089	4	80.0%	4	80.0%	2,936.8
1	106 - 217	0	0.0%	4	80.0%	
1	0 - 105	1	20.0%	5	100.0%	
1	.....	.....	.....	.....	.....	
2	210 - 505	0	0.0%	0	0.0%	84.0
2	206 - 209	0	0.0%	0	0.0%	
2	0 - 205	3,001	100.0%	3,001	100.0%	
2	.....	.....	.....	.....	.....	
3	936 - 28,665	0	0.0%	0	0.0%	574.3
3	0 - 935	101	100.0%	101	100.0%	
3	.....	.....	.....	.....	.....	

Figure 203. Data Set Statistics report for an HDAM (IPR Reload utility)

The following figure shows the Data Set Statistics with the Distribution of Free Space section for a PHIDAM.

"DATA SET STATISTICS"

--- PARTITION=PHI003A ---

DSG	DDNAME	BLOCK SIZE	RECORD SIZE	DATA SET NAME
A	PHI003AA	4,096	4,096	TEMPDS.ORFF0106.PHI00300.A00001
B	PHI003AB	512	512	TEMPDS.ORFF0106.PHI00300.B00001
C	PHI003AC	28,672	28,672	TEMPDS.ORFF0106.PHI00300.C00001

DSG	DDNAME	FBFF	FSPF	FSPF BYTES	SMALL SEGSZE	LARGE SEGSZE	FSE THRESHOLD	TOTAL BLOCKS
A	PHI003AA	0	0	0	918	930	930	1,502
B	PHI003AB	0	0	0	42	48	48	3
C	PHI003AC	0	0	0	948	948	948	201

<<< DISTRIBUTION OF FREE SPACE >>>

DSG	FREE SPACE RANGE	NUMBER OF BLOCKS	PCT OF TOTAL BLKS	<---CUMULATIVE--->		AVG SIZE OF FREE SPACE
				NUMBER OF BLOCKS	PCT OF TOTAL BLKS	
A	930 - 4,096	1	50.0%	1	50.0%	1,112.0
A	918 - 929	0	0.0%	1	50.0%	
A	0 - 917	1	50.0%	2	100.0%	
A	.....					
B	48 - 512	0	0.0%	0	0.0%	0.0
B	42 - 47	0	0.0%	0	0.0%	
B	0 - 41	1	100.0%	1	100.0%	
B	.....					
C	948 - 28,672	0	0.0%	0	0.0%	0.0
C	0 - 947	1	100.0%	1	100.0%	
C	.....					

Figure 204. Data Set Statistics report for a PHIDAM (IPR Reload utility) (Part 1 of 3)

"DATA SET STATISTICS"

--- PARTITION=PHI003B ---

DSG	DDNAME	BLOCK SIZE	RECORD SIZE	DATA SET NAME
A	PHI003BA	4,096	4,096	TEMPDS.ORFF0106.PHI00300.A00002
B	PHI003BB	512	512	TEMPDS.ORFF0106.PHI00300.B00002
C	PHI003BC	28,672	28,672	TEMPDS.ORFF0106.PHI00300.C00002

DSG	DDNAME	FBFF	FSPF	FSPF BYTES	SMALL SEGSZ	LARGE SEGSZ	TOTAL BLOCKS
A	PHI003BA	0	0	0	918	930	1,502
B	PHI003BB	0	0	0	42	48	3
C	PHI003BC	0	0	0	948	948	201

<<< DISTRIBUTION OF FREE SPACE >>>

DSG	FREE SPACE RANGE	NUMBER OF BLOCKS	PCT OF TOTAL BLKS	<---CUMULATIVE--->		AVG SIZE OF FREE SPACE
				NUMBER OF BLOCKS	PCT OF TOTAL BLKS	
A	930 - 4,096	1	0.1%	1	0.1%	421.5
A	918 - 929	0	0.0%	1	0.1%	
A	0 - 917	1,501	99.9%	1,502	100.0%	
A	.....					
B	48 - 512	1	33.3%	1	33.3%	38.7
B	42 - 47	0	0.0%	1	33.3%	
B	0 - 41	2	66.7%	3	100.0%	
B	.....					
C	948 - 28,672	0	0.0%	0	0.0%	226.9
C	0 - 947	201	100.0%	201	100.0%	
C	.....					

Figure 205. Data Set Statistics report for a PHIDAM (IPR Reload utility) (Part 2 of 3)



"DATA SET STATISTICS"

--- PARTITION=PHI003C ---

DSG	DDNAME	BLOCK SIZE	RECORD SIZE	DATA SET NAME
A	PHI003CA	4,096	4,096	TEMPDS.ORFF0106.PHI00300.A00003
B	PHI003CB	512	512	TEMPDS.ORFF0106.PHI00300.B00003
C	PHI003CC	28,672	28,672	TEMPDS.ORFF0106.PHI00300.C00003

DSG	DDNAME	FBFF	FSPF	FSPF BYTES	SMALL SEGSZE	LARGE SEGSZE	TOTAL BLOCKS
A	PHI003CA	0	0	0	918	930	2
B	PHI003CB	0	0	0	42	48	1
C	PHI003CC	0	0	0	948	948	1

<<< DISTRIBUTION OF FREE SPACE >>>

DSG	FREE SPACE RANGE	NUMBER OF BLOCKS	PCT OF TOTAL BLKS	<---CUMULATIVE--->		AVG SIZE OF FREE SPACE
				NUMBER OF BLOCKS	PCT OF TOTAL BLKS	
A	930 - 4,096	1	50.0%	1	50.0%	1,112.0
A	918 - 929	0	0.0%	1	50.0%	
A	0 - 917	1	50.0%	2	100.0%	
A	.....	.....	.....	.....	.....	
B	48 - 512	0	0.0%	0	0.0%	0.0
B	42 - 47	0	0.0%	0	0.0%	
B	0 - 41	1	100.0%	1	100.0%	
B	.....	.....	.....	.....	.....	
C	948 - 28,672	0	0.0%	0	0.0%	0.0
C	0 - 947	1	100.0%	1	100.0%	
C	.....	.....	.....	.....	.....	

Figure 206. Data Set Statistics report for a PHIDAM (IPR Reload utility) (Part 3 of 3)

The following figure shows the Data Set Statistics with the Distribution of Free Space section for a HISAM.

"DATA SET STATISTICS"

TYPE	DDNAME	BLOCK SIZE	RECORD SIZE	DATA SET NAME
PRIM	DDHS0010	4,096	1,362	TEMPDS.ORFF1206.DBHS0010.DDHS001B
OVFL	DDH00010	8,192	1,362	TEMPDS.ORFF1206.DBHS0010.DDH0001B

TYPE	DDNAME	SMALL SEGSZE	LARGE SEGSZE	TOTAL BLOCKS
PRIM	DDHS0010	102	932	2
OVFL	DDH00010	102	932	1

Figure 207. Data Set Statistics report for a HISAM (IPR Reload utility)

The meanings of the fields in the Data Set Statistics report are as follows:

**PARTITION**

The partition name. This field is printed only for a HALDB.

**DSG**

The data set group number. For an HDAM or a HIDAM database, this field shows a number; for a HALDB, an alphabet; for a HISAM or a SHISAM database, this field is not printed.

**TYPE**

The type of the database data set of a HISAM database. This field is printed only for a HISAM or a SHISAM database. The value of TYPE means as follows:

**PRIM:**

the primary data set

**OVFL:**

the overflow data set

**DDNAME**

The ddname as coded on the \*1 keyword in the DBD, or the \*2 field registered in RECON as ddname for each data set group (or for each type of database data set in a HISAM or a SHISAM database).

\*1 keyword as follows in each database:

- HDAM: DD1=
- HIDAM: DD1=
- HISAM or SHISAM: DD1=
- HISAM: OVFLW=

\*2 field as follows in each database:

- PHDAM: DDN=
- PHIDAM: DDN=

**BLOCK SIZE**

The block size or the CI size of the database data set for each data set group (or for each type of database data set in a HISAM or a SHISAM database).

**RECORD SIZE**

The logical record length of each data set group (or for each type of database data set in a HISAM or a SHISAM database).

**DATA SET NAME**

The data set name of each data set group (or for each type of database data set in a HISAM or a SHISAM database). For a VSAM data set, only the name of the VSAM cluster is printed.

**FBFF**

The value of the free block frequency factor, of each data set group, specified in the FRSPC=(*fbff,fsfpf*) keyword of the DBD. This field is printed only for an HDAM, a HIDAM, a PHDAM, or a PHIDAM database.

**FSPF**

The value of the free space percentage factor, of each data set group, specified in the FRSPC=(*fbff,fsfpf*) keyword of the DBD. This field is printed only for an HDAM, a HIDAM, a PHDAM, or a PHIDAM database.

**FSPF BYTES**

The number of bytes to be removed as free space from the database data set in each data set group. This value is calculated from the values in FSPF (the minimum percentage of each control interval or block that is to be left as free space in this data set group). This field is printed only for an HDAM, a HIDAM, a PHDAM, or a PHIDAM database.

**SMALL SEGSZE**

- For an HDAM, a HIDAM, a PHDAM, or a PHIDAM database:
  - The shortest segment length of all segments that belong to each data set group.
- For a HISAM or a SHISAM database:
  - PRIM: The shortest segment length of all segments.
  - OVFL: The shortest segment length in segments other than the root segment.

The segment length includes both the length of the prefix portion and the data portion. For the length of the data portion, the maximum bytes specified in the BYTES= keyword in the SEGM statement of the DBDGEN—and not the actual length—is used.

### **LARGE SEGSZE**

- For an HDAM, a HIDAM, a PHDAM, or a PHIDAM database:
  - The longest segment length of all segments that belong to each data set group.
- For a HISAM or a SHISAM database:
  - PRIM: The longest segment length of all segments.
  - OVFL: The longest segment length in segments other than the root segment.

The segment length includes both the prefix portion and the data portion. For the length of the data portion, the maximum bytes specified in the BYTES= keyword in the SEGM statement of the DBDGEN—and not the actual length—is used.

When COMPRTN=(,,max) is specified, the length of the data portion is the maximum bytes specified in the BYTES= keyword of the DBD plus 10 (bytes).

### **FSE THRESHOLD**

The threshold value that is used to set the bitmap block, which indicates whether each block has a free space element that is large enough to store a new occurrence. If BMSETDSG control statement is specified, the specified value is shown instead of the LARGE SEGSZE value.

This field is printed only for an HDAM, a HIDAM, a PHDAM, or a PHIDAM database.

### **TOTAL BLOCKS**

The total number of blocks or CIs in each data set group (or in each type of database data set in a HISAM or a SHISAM database).

For a VSAM data set, this field does not include record 0.

### **NUMBER OF BLOCKS IN OVERFLOW**

The number of blocks or the number of CIs in the overflow area of an HDAM or a PHDAM database. This field is printed only for an HDAM or a PHDAM database.

### **<<< DISTRIBUTION OF FREE SPACE >>>**

#### **DSG**

The data set group number. For an HDAM or a HIDAM database, this field shows a number; for a HALDB, an alphabet.

#### **FREE SPACE RANGE**

The ranges of free space size of each data set group. Each range is expressed by the fields RECORD SIZE, SMALL SEGSZE, and LARGE SEGSZE as follows:

- When the values of SMALL SEGSZE and LARGE SEGSZE are different, there are the following three ranges:

LARGE SEGSZE to RECORD SIZE

SMALL SEGSZE to LARGE SEGSZE-1

0 to SMALL SEGSZE-1

- When the values of SMALL SEGSZE and LARGE SEGSZE are the same, there are the following two ranges:

LARGE SEGSZE to RECORD SIZE

0 to LARGE SEGSZE-1

**Note:** When the BMSETDSG control statement is specified, the specified value is shown instead of the LARGE SEGSZE value.

If the value is larger than the record size, the following two ranges are shown:

- SMALL SEGSIZE to RECORD SIZE
- 0 to SMALL SEGSIZE-1

**NUMBER OF BLOCKS**

For each FREE SPACE RANGE, the number of blocks or CIs containing a free space element (FSE) that fall within the free space range.

**PCT OF TOTAL BLKS**

For each FREE SPACE RANGE, the percentage of the number of blocks or CIs contained in the free space range within all blocks or CIs.

**<-----CUMULATIVE----->**

**NUMBER OF BLOCKS**

The cumulative total of NUMBER OF BLOCKS up to the FREE SPACE RANGE.

**PCT OF TOTAL BLKS**

The cumulative total of PCT OF TOTAL BLKS up to the FREE SPACE RANGE.

**AVG SIZE OF FREE SPACE**

The average size of free space of each data set group.

## I/O Statistics report

This report contains the I/O information about the database records that are reloaded.

The following figure is an example of the I/O Statistics report. This report is not generated for a HISAM or a SHISAM database. For a HALDB, this report is generated for each partition.

```

IMS HIGH PERFORMANCE LOAD                                PAGE:          1
5655-M26                                                08/06/2023 09.30.10

                                "I/O STATISTICS"

DS GROUP = 1  DDNAME = DDHDV10

NUMBER OF SEQUENTIAL WRITES.....                          6
NUMBER OF DIRECT READS.....                               1
NUMBER OF DIRECT WRITES.....                              1

NUMBER OF DSPB ROUTINGS.....                               0
HIGHEST LENGTH OF DATA IN DSPB.....                      0
AVERAGE LENGTH OF DATA IN DSPB.....                     0.0

DS GROUP = 2  DDNAME = DDHDV11

NUMBER OF SEQUENTIAL WRITES.....                          3,002
NUMBER OF DIRECT READS.....                               1
NUMBER OF DIRECT WRITES.....                              1

NUMBER OF DSPB ROUTINGS.....                               5
HIGHEST LENGTH OF DATA IN DSPB.....                     56,320
AVERAGE LENGTH OF DATA IN DSPB.....                     56320.0

DS GROUP = 3  DDNAME = DDHDV12

NUMBER OF SEQUENTIAL WRITES.....                          102
NUMBER OF DIRECT READS.....                               1
NUMBER OF DIRECT WRITES.....                              1

NUMBER OF DSPB ROUTINGS.....                               5
HIGHEST LENGTH OF DATA IN DSPB.....                     57,344
AVERAGE LENGTH OF DATA IN DSPB.....                     57344.0

```

Figure 208. I/O Statistics report

The meanings of the fields in the I/O Statistics report are as follows:

**PARTITION**

The partition name. This field is printed only for a HALDB.

**DS GROUP**

The data set group number. For an HDAM or a HIDAM database, this field shows a number; for a HALDB, an alphabet.

**DDNAME**

The ddname as coded on the \*1 keyword in the DBD, or the \*2 field registered in RECON as ddname.

\*1 keyword as follows in each database:

- HDAM: DD1=
- HIDAM: DD1=

\*2 field as follows in each database:

- PHDAM: DDN=
- PHIDAM: DDN=

**NUMBER OF SEQUENTIAL WRITES**

The number of sequential write operations to the database data set.

**NUMBER OF DIRECT READS**

The number of direct read operations to the database data set.

**NUMBER OF DIRECT WRITES**

The number of direct write operations to the database data set.

**NUMBER OF DSPB ROUTINGS**

The number of times data is written to and from the data space buffer (DSPB).

**HIGHEST LENGTH OF DATA IN DSP**

The maximum length of the data in DSPB.

**AVERAGE LENGTH OF DATA IN DSPB**

The average length of the data written into DSPB.

## Pointer Count Summary report

This report contains a list of all the pointers to a user-specified target, and various totals for each segment pointer type.

The following figure shows an example of the Pointer Count Summary report for an HDAM database.

IMS HIGH PERFORMANCE LOAD 5655-M26			PAGE: 1 08/06/2023 09.30.06	
"POINTER COUNT SUMMARY"				
SOURCE SEGMENT	TARGET SEGMENT	PTR TYPE	NBR OF ZERO PTR	SOURCE SEGMENTS WITH PTR
-----	-----	-----	-----	-----
ROOTLEV1	ROOTLEV1	PTF	4	1
	DEP1LEV2	PCF	0	5
	DEP2LEV2	PCF	0	5
	DEP4LEV2	PCF	0	5
DEP1LEV2	DEP1LEV2	PTF	5	0
DEP2LEV2	DEP2LEV2	PTF	5	2,995
	DEP3LEV3	PCF	0	3,000
DEP3LEV3	DEP3LEV3	PTF	3,000	0
DEP4LEV2	DEP4LEV2	PTF	5	2,995

Figure 209. Pointer Count Summary report for an HDAM database

The following describes the Pointer Count Summary report shown in [Figure 209 on page 573](#). All values in the report are decimal.

**SOURCE SEGMENT**

The segment name that has one or more pointers in its prefix.

## TARGET SEGMENT

The segment name that is pointed by the source segment.

## PTR TYPE

The type of pointer used. For each pointer in a prefix, a line of information is printed. If the pointer type is HF or HB, the TARGET SEGMENT field contains an asterisk (\*).

## NBR OF SOURCE SEGMENTS ZERO PTR

The number of occurrences of the source segment for which this pointer is zero.

## NBR OF SOURCE SEGMENTS WITH PTR

The number of occurrences of the source segment for which this pointer has an RBA. If the pointer type is PCF, this number indicates the number of physical twin chains in the database for the target segment type.

**Note:** If hierarchical pointers are used, the target segment name is not printed because hierarchical pointers can point to different segment types.

The Pointer Count Summary report also provides the following information:

- If the given segment type has PTF pointers, you can obtain the number of twin chains for a given segment type by looking in the SOURCE SEGMENT field and the NBR OF SOURCE SEGMENTS ZERO PTR field for the given segment type. If the given segment type has hierarchical pointers, but its parent has a PCF pointer pointing to the given segment type, you can also obtain this number by looking in the TARGET SEGMENT, PTR TYPE, and NBR OF SOURCE SEGMENTS WITH PTR fields.
- You can obtain the average number of twin chain occurrences for a given segment type by using the number of twin chains just described. After determining the number of twin chains, divide that number into the total number of source segments (ZERO PTR + WITH PTR) for the segment type.

## Pointer Statistics report

This report contains a list of all the pointers to a user-specified target, and various totals and ratios for each segment pointer type.

The following figure shows an example of the Pointer Statistics report for an HDAM database.

IMS HIGH PERFORMANCE LOAD		PAGE: 1						
5655-M26		08/06/2023 09.30.06						
"POINTER STATISTICS"								
SOURCE SEGMENT	TARGET SEGMENT	PTR TYPE	NBR OF PTRS (POINT TO)			AVERAGE BLOCKS AWAY	I/O PROB	
			SAME BLOCK	DIFF BLOCK	ONE BLOCK AWAY			
ROOTLEV1	ROOTLEV1	PTF	1	0	0	0.0	.000	
	DEP1LEV2	PCF	5	0	0	0.0	.000	
	DEP2LEV2	PCF					1.000	
	DEP4LEV2	PCF					1.000	
DEP1LEV2	DEP1LEV2	PTF	0	0	0	0.0	.000	
DEP2LEV2	DEP2LEV2	PTF	0	2,995	2,995	1.0	1.000	
	DEP3LEV3	PCF	3,000	0	0	0.0	.000	
DEP3LEV3	DEP3LEV3	PTF	0	0	0	0.0	.000	
DEP4LEV2	DEP4LEV2	PTF	2,900	95	95	1.0	.032	

Figure 210. Pointer Statistics report

The following describes the Pointer Statistics report shown in [Figure 210 on page 574](#). All values in the report are decimal.

## SOURCE SEGMENT

The segment name that has one or more pointers in its prefix.

## TARGET SEGMENT

The segment name that is pointed by the source segment.

## PTR TYPE

The type of pointer used. For each pointer in a prefix, a line of information is printed. If the pointer type is HF or HB, the TARGET SEGMENT field contains an asterisk (\*).

## NBR OF PTRS (POINT TO) SAME BLOCK

The number of pointers of the given type that point to segments in the same physical block or CI.

## NBR OF PTRS (POINT TO) DIFF BLOCK

The number of pointers of the given type that point to segments in a different block or CI.

## NBR OF PTRS (POINT TO) ONE BLOCK AWAY

A refinement of the NBR OF PTRS (POINT TO) DIFF BLOCK data. For those pointers that point to segments in different blocks, this is the number of pointers that point to the next or previous block or CI.

## AVERAGE BLOCKS AWAY

A refinement of the NBR OF PTRS (POINT TO) DIFF BLOCK data. For those pointers that point to segments in different blocks, this is the average number of blocks away. You can manually translate this number into tracks and cylinders by knowing the number of blocks or CIs per track. This data can be used to estimate how far apart the source and target segments are. The larger this number is, the longer the seeks will be.

## I/O PROB

The probability of doing I/O in going from the source segment to the target segment using the indicated pointer type. This is a very important item in doing database performance analysis. You can use the I/O PROB information to estimate the number of I/Os needed to retrieve a given segment or sequence of segments.

## Notes:

- If the source and target segments are in different data set groups, the columns associated with NBR OF PTRS and AVERAGE BLOCKS AWAY are left blank because the data would be meaningless.
- If hierarchical pointers are used, the target segment name is not printed because hierarchical pointers can point to different segment types.

## WFP Process Summary report

This report summarizes information about the WFP data sets that are created in the job.

The following figure shows an example of the WFP Process Summary report.

```
IMS HIGH PERFORMANCE LOAD                                PAGE:      1
5655-M26                                                10/01/2023 14.33.18

                "WFP PROCESS SUMMARY"

WFP DATA SETS INFORMATION

 P PARTITION DDNAME   DSNAME
-----
 L PHDV20A   HPSRP001 IMSTOOLS.WORK.HMPORDP1.PHDV020A.WFP
 I PHDV20B   HPSRP002 IMSTOOLS.WORK.HMPORDP1.PHDV020B.WFP
 L PHDV20C   HPSRP003 IMSTOOLS.WORK.HMPORDP1.PHDV020C.WFP

INDEX ENTRIES SUMMARY

PARTITION  PSINDEX  INDEX ENTRIES
-----
PHDV20A   PSIDX01   420,142,550
          PSIDX02   1,892,333

PARTITION  PSINDEX  INDEX ENTRIES
-----
PHDV20C   PSIDX01   15,293,320
          PSIDX02           0
```

Figure 211. WFP Process Summary report

**P**

The status of the WFP data sets.

**I**

Initialized and is empty.

**L**

Loaded.

**PARTITION**

The HALDB partition name of the database.

**DDNAME**

The DD name of the WFP data set.

**DSNAME**

The name of the WFP data set.

**PSINDEX**

The name of the partitioned secondary index database.

**INDEX ENTRIES**

The number of index pointer segment entries in the WFP data set.

## HALDB Partition Definition report

This report contains the definition information about a HALDB. It is generated only for a HALDB.

The following figures show examples of HALDB Partition Definition reports.

**Note:** If you specify PARTINFO=NO, the report is not generated even for HALDBs.

The following figure shows an example of a case where the high key selection is used. The keys used are in hexadecimal.

```

IMS HIGH PERFORMANCE LOAD                                PAGE:          1
5655-M26                                                  08/05/2023 10.32.19

                "HALDB PARTITION DEFINITION"

PARTITIONS LISTED IN ORDER OF HIGH KEY

  SEQ PARTITION   ID PARTITION HIGH KEY
-----
0001 PHD003A     1 X'F0F0F0F0F0F0F0F2'
0002 PHD003B     2 X'F0F0F0F0F0F0F2F0'
0003 PHD003C     3 X'FFFFFFFFFFFFFFFF'

```

Figure 212. HALDB Partition Definition report when the high key selection is used (IPR Reload utility)

The following figure shows an example of a case where the partition selection exit is used. The keys used are character string format.

```

IMS HIGH PERFORMANCE LOAD                                PAGE:          1
5655-M26                                                  08/05/2023 10.32.19

                "HALDB PARTITION DEFINITION"

PARTITIONS LISTED IN ORDER OF PARTITION NAME

  SEQ PARTITION   ID PARTITION SELECTION STRING
-----
0001 PHD003A     1 C'19999999'
0002 PHD003B     2 C'29999999'
0003 PHD003C     3 C'49999999'

```

Figure 213. HALDB Partition Definition report when the partition selection exit is used (IPR Reload utility)

The meanings of the fields in the HALDB Partition Definition report are as follows:

**PARTITIONS LISTED IN ORDER OF HIGH KEY**

This is printed only when the high key selection is used.



## PARTITIONS LISTED IN ORDER OF PARTITION NAME

This is printed only when the partition selection exit is used.

## SEQ

The sequence number. These are printed in the order of the key when the high key selection is used. They are printed in the order of the partition name when the partition selection exit is used.

## PARTITION

The partition name defined by the IMS HALDB Partition Definition utility

## ID

The partition ID number

## PARTITION HIGH KEY

The value of the high key. It is printed only when the high key selection is used.

- In character string format, if TYPE=C is specified for the Root Sequence Key Field in DBDGEN, and if the high key can be printed in characters. Otherwise, in hexadecimal representation.
- In hexadecimal representation, if anything other from TYPE=C has been specified for Root Sequence Key Field in DBDGEN.

## PARTITION SELECTION STRING

The value of the partition selection string. It is printed only when the partition selection exit is used.

This field checks whether each partition of a database can be displayed in character string format, and does so if possible. Otherwise, it displays it in hexadecimal representation.

## DBRC Messages report

This report contains DBRC messages when DBRC=Y is specified for a non-HALDB.

The following figure shows an example of DBRC Messages reports.

**Note:** DBRC messages for a HALDB are contained in the Messages report

```
IMS HIGH PERFORMANCE LOAD                                PAGE:          1
5655-M26                                                08/04/2023  19.05.04

                                "DBRC MESSAGES"

DSP0132I  IMAGE COPY NEEDED FOR
DSP0132I  DBDNAME=DBHDV10  DDNAME=DDHV10
DSP0132I  IMAGE COPY NEEDED FOR
DSP0132I  DBDNAME=DBHDV10  DDNAME=DDHV11
DSP0132I  IMAGE COPY NEEDED FOR
DSP0132I  DBDNAME=DBHDV10  DDNAME=DDHV12
```

Figure 214. Messages report for DBRC messages

## GDG Base Information report

This report contains the messages that were issued while creating a GDG base entry.

The following figure is an example of the GDG Base Information report.

```
IMS HIGH PERFORMANCE LOAD                                PAGE:          1
5655-M26                                                10/01/2023  19.05.04

                                "GDG BASE INFORMATION"

*** GDG BASE CREATION FOR DFSURWF1 ***

DEFINE GDG (NAME(TEMPDS.GDGTSTM) -
          LIM(5))
IDC0001I FUNCTION COMPLETED, HIGHEST CONDITION CODE WAS 0

IDC0002I IDCAMS PROCESSING COMPLETE. MAXIMUM CONDITION CODE WAS 0
```

Figure 215. GDG Base Information report

## HPSSNAP data set: DBD Snap report

The HPSSNAP data set contains the DBD Snap Dump report.

The following figure shows an example of the DBD Snap report. This report provides a snapshot of the DBD if the DBDSNAP=YES statement is specified in the HPSIN data set.

When a snap is taken, the DBD and some of the IPR Reload utility control blocks are provided. The snap gives the virtual storage addresses of the data traced on the right. There might be multiple lines, each showing up to 32 bytes of data in the hexadecimal and EBCDIC format.

```

IMS HIGH PERFORMANCE LOAD                                "DBD SNAP DUMP"                                PAGE: 1
5655-M26                                                08/26/2023 18:18:14

DBD MEMBER FOLLOWS ON SNAP

JOB ORFF2133      STEP HPLD      TIME 181814  DATE 23239   ID = 119   CPUID = FF0122029672  PAGE 00000001

  PSW AT ENTRY TO SNAP  078D1000  800C73F2  ILC 02  INTC 0033
-STORAGE
00012DE0
00012E00 00012F8C 00012FB8 00012FC8 00012FBC      30012E18 00012E6C 00012EFC 00012F9C      *
00012E20 00020003 0E010001 40404040 40404040      00000000 00012FC8 C4C2C8C4 F1F0F7F0      *.....H.....HDBHD1070*
00012E40 F1F0F7F0 40404040 01030003 0026001A      00010000 00000000 FFFFFFFF C4C4C8C4      *.....DDHD*
00012E60 40404040 00000000 FFFFFFFF 01010001      00080008 07F90800 07F90800 40404040      *1070.....9...9...*
00012E80 60EF0002 00000000 0000FFFF 00000000      01020014 00000000 D9D6D6E3 D3C5E5F1      *.....ROOTLEV1*
00012EA0 00020015 00000000 C4C5D7F1 D3C5E5F2      00120000 00000000 00000000 01020102      *--.....*
00012EC0 000A0000 00000000 00000000 01030102      60EF0000 FFFFFFFF 0000FFFF 00000030      *.....DEP1LEV2-.....*
00012EE0 40EF0000 FFFFFFFF 0000FFFF 00000060      00020014 00000000 C4C5D7F2 D3C5E5F2      *.....DEP2LEV2*
00012F00 D5D64040 00004307 40404040 40404040      00060000 00000000 00000000 D9D6D6E3      *.....ROOT*
00012F20 40404040 40404040 00000000 C4C5D7F1      00000000 D9D6D6E3 D5C1D4C5 0008830B      *NO.....ROOTNAME...c.*
00012F40 00000030 C4C5D7F1 D5C1D4C5 0008830C      D5D64040 00000307 40404040 40404040      *.....DEP1NO.....*
                                           40404040 40404040 00000030 C4C5D7F2      *....DEP1NAME...c....DEP2*

```

Figure 216. DBD Snap report

---

## Chapter 38. User exits for IPR Reload

The user exit enables you to exercise additional selectivity or modification of segments before the segment data is written into the database data set.

This topic describes the interface of the user exits for the IPR Reload utility. It is a product-sensitive programming interface.

PSPI

If you want additional processing or edit segments during the database reload, you can provide your own user exit routine. You can code these routines using the following languages:

- Assembly language
- Enterprise COBOL for z/OS
- Enterprise PL/I for z/OS

**Note:** When the user exit is written in Enterprise COBOL for z/OS or Enterprise PL/I for z/OS, it must be run in the Language Environment (LE).

PSPI

### Topics:

- [“User exit interface” on page 579](#)
- [“Register contents upon entry to the user exit” on page 580](#)
- [“Register contents upon return from the user exit” on page 581](#)
- [“Considerations for using Enterprise COBOL for z/OS program user exit” on page 581](#)
- [“Considerations for using Enterprise PL/I for z/OS program user exit” on page 582](#)
- [“Sample user exits” on page 582](#)

## User exit interface

---

The user exit routine is invoked after every reading of segment data from the HD unloaded data set.

PSPI

You can use the user exit routine to check, modify, delete, and control the placement of segments.

**Notice:** When you use the user exit routine for a HALDB, you cannot modify or delete the key field of the root segment in your user exit. If you need to do so, you can by using Physical Sequence Sort for Reload (PSSR) of IMS HP Load for z/OS. For details, see the *IMS High Performance Load User's Guide*.

If the segment data is compressed with the DECOMPRESS=NO option specification in an Unload job, the IPR Reload utility calls the segment edit/compression exit routine to decompress the segment data before calling the user exit routine, and calls the segment edit/compression exit routine to compress the segment data after calling the user exit routine. This decompression and compression are performed even if COMPRESS=NO is specified in the HPSIN data set. The user exit routine can be coded in assembly language, Enterprise COBOL for z/OS, or Enterprise PL/I for z/OS. When the user exit is written in Enterprise COBOL for z/OS or Enterprise PL/I for z/OS, it must be run in the Language Environment (LE). You must specify "L" on the INPUT control statement in the HPSIN data set, so that the IPR Reload utility establishes the LE environment by using the preinitialization services. The user exit is invoked by the CEEPIPI *call\_sub* function.

The user exit routine can be AMODE=31 and RMODE=24.

The library in which the user exit routine is stored must be concatenated to the STEPLIB DD statement.

## Register contents upon entry to the user exit

The following tables show register contents upon entry to the user exit routine.

Table 82. Register contents upon entry to a user exit

Register	Content
1	Parameter list pointer
13	Register save area pointer
14	Return address
15	Entry point address of the user exit

Table 83. Parameter list pointed to by Register 1 upon entry to a user exit

Word	Content
1	Address of segment name
2	Address of segment data
3	Address of work area
4	Address of DBD name

### A(segment name)

Address of a 9-byte area that contains an 8-byte segment name and a 1-byte segment code in hexadecimal. At the end of the user exit routine, the first 8 bytes of the area contain blanks.

### A(segment data)

Address of the segment data read from the HD unloaded data set. The IPR Reload utility always decompresses compressed data before presenting it to the user exit routine.

### A(work area)

Address of a segment work area that is large enough to hold the largest possible segment defined in the DBD being used. If a segment length change is required, this area must be used.

For variable length segments, you must change the segment length (LL field) by the user exit routine to an appropriate size of the segment being modified. The segment length must not exceed the maximum segment length defined in the DBD being used. The amount of segment data moved into the database data set is controlled by the LL field.

For fixed-length segments, the amount of segment data moved into the database data set is controlled by the segment length defined in the DBD. It is your responsibility to initialize the expanded portion of the segment by the user exit routine if the segment length in the DBD has been expanded. If a return code of zero is returned from the user exit routine, the IPR Reload utility moves unchanged segment data into the database data set, and automatically initializes the expanded portion of the segment with binary zeros.

### A(DBD name)

Address of an 8-byte area that contains a DBD name of the database to be processed.

## Register contents upon return from the user exit

The following table shows register contents upon return from the user exit routine.

PSPI

Table 84. Register contents upon return from a user exit

Register	Content
15	Return code

At the exit point of the user exit routine, register 15 must contain the return code so that the IPR Reload utility can determine the correct process of the segment data. The return code must be one of the following shown in the following table.

Table 85. Return codes

Return code	Meaning
0	Indicates no segment modification. The IPR Reload utility uses the segment data pointed to by the second word of the parameter list.
4	Indicates segment modification. The IPR Reload utility uses the segment data pointed to by the third word of the parameter list.
8	Indicates segment deletion. The IPR Reload utility skips the segment data. The user exit routine must return the return code 8 for all dependent segments of this segment.
12	Indicates segment and all subsequent segments deletion. The IPR Reload utility skips this segment and all subsequent segments' data in the same database record.
16	Indicates a locate request of an HDAM or a PHDAM segment into the overflow area. The IPR Reload utility places the segment data into the HDAM overflow area.
20	Indicates a locate request of a HIDAM or a PHIDAM segment into a new block. The IPR Reload utility places the segment data into a new block.
100–999	Indicates termination. The IPR Reload utility ends the loading process and passes this return code back as the job return code. The available return code value is in the range of 100 - 999.

PSPI

## Considerations for using Enterprise COBOL for z/OS program user exit

If your exit routine for the IPR Reload utility is written in COBOL and runs in the Language Environment (LE), be careful when coding the user exit and the COBOL compile options that handles the runtime environment.

PSPI

### Coding considerations:

- The return code must be set in RETURN-CODE.
- STOPRUN cannot be used in the program.

**Compiling Considerations:**

The user exit routine is called in the Language Environment (LE). LE libraries need to be used as follows:

- SCEERUN is needed during the compiling of the user exit and running the IPR Reload utility.
- SCEELKED is needed during the linkage-editing process of the user exit.

When your exit routine is written in COBOL and runs the Language Environment (LE), L must be specified after the user exit name in the HPSIN data set.

PSPI

## Considerations for using Enterprise PL/I for z/OS program user exit

---

If your exit routine for the IPR Reload utility is written in PL/I and runs in the Language Environment (LE), be careful when coding the user exit and the PL/I compile options that handles the runtime environment.

PSPI

**Coding considerations:**

- The PL/I user exit routine is loaded dynamically and called by PSSR as a subprogram. It needs to be specified as OPTIONS(FETCHABLE) on the procedure statement in the program. OPTIONS(MAIN) cannot be specified.
- The parameters in the PL/I routine must be declared as pointer variables.
- The PL/I built-in function PLIRETC or LE callable service CEE3SRC can be used to set the return code.
- POSIX(ON) cannot be specified for the LE runtime option.
- Nested or multiple enclaves are not supported. For more information about the nested enclave, see the *Programming Guide* for LE.

**Compiling considerations:**

The user exit routine is called in the Language Environment (LE). LE libraries need to be used as follows:

- SCEERUN is needed during compiling the user exit and running the IPR Reload utility.
- SCEELKED is needed during the linkage-edit process of the user exit.

When your exit routine is written in PL/I and runs in the Language Environment (LE), L must be specified following after the user exit name in the HPSIN data set.

PSPI

## Sample user exits

---

The following sample user exits are available in the HPS.SHPSSAMP data set of IMS HP Load.

**HPSRXAA0**

A sample user exit written in assembly language.

**HPSRXCC1**

A sample user exit written in Enterprise COBOL for z/OS.

**HPSRXPP1**

A sample user exit written in Enterprise PL/I for z/OS.

---

## Part 7. Scanning a database to resolve logical relationships

The following topics explain how to use the IPR DB Scan utility to scan the logically related databases that are not reorganized.

**Topics:**

- [Chapter 39, “IPR DB Scan utility,” on page 585](#)
- [Chapter 40, “IPR DB Scan JCL requirements,” on page 587](#)
- [Chapter 41, “IPR DB Scan control statements,” on page 591](#)
- [Chapter 42, “IPR DB Scan JCL examples,” on page 597](#)
- [Chapter 43, “IPR DB Scan reports,” on page 601](#)





---

## Chapter 39. IPR DB Scan utility

The IPR DB Scan utility identifies the segments that contain logical relationships that are affected when related databases are loaded, reorganized, or both. For each segment affected, the utility generates one or more output records, depending on the relationships in which the segment is involved.

### Topics:

- [“IPR DB Scan overview” on page 585](#)
- [“Data flow for IPR DB Scan” on page 585](#)
- [“IPR DB Scan restrictions and considerations” on page 586](#)

---

### IPR DB Scan overview

The IPR DB Scan utility has the same function as the IMS Database Scan utility. The elapsed time is considerably shorter than that of the IMS Database Scan utility.

The IPR DB Scan utility is implemented as a function of the IPR Unload utility and uses HSSR Engine of IMS HP Unload to scan databases. It enables scanning faster the databases than by using the standard IMS Database Scan utility. It also increases the efficiency of the database reorganization process.

The detailed description of the scan process is not provided because the IPR DB Scan utility is a functional replacement for the IMS Database Scan utility (DFSURGS0). It is assumed that you are familiar with the process.

The scan utility serves an important part in the scan process of a database that contains logical relationships. You can run the IPR DB Scan utility as part of an initial load or reorganization of such a database.

The IPR DB Scan utility supports the following database organizations:

- HDAM
- HIDAM
- HISAM

The database data sets can be allocated dynamically by using DFSMDA members. DBRC is supported.

---

### Data flow for IPR DB Scan

The IPR DB Scan utility processes the DFSURCDS data set, which is generated by the IMS Database Prereorganization utility.

The IPR DB Scan utility locates segments containing logical relationships that are affected when other databases are loaded or reorganized. For each segment affected, the utility generates one or more output records, depending on the relationships in which that segment is involved.

The records are written to an output work data set allocated for this utility. This is the DFSURWF1 data set, and is used as the input to the IMS Database Prefix Resolution utility for resolving logical relationship pointers defined for the database.

The following figure shows the general data flow for the IPR DB Scan utility.

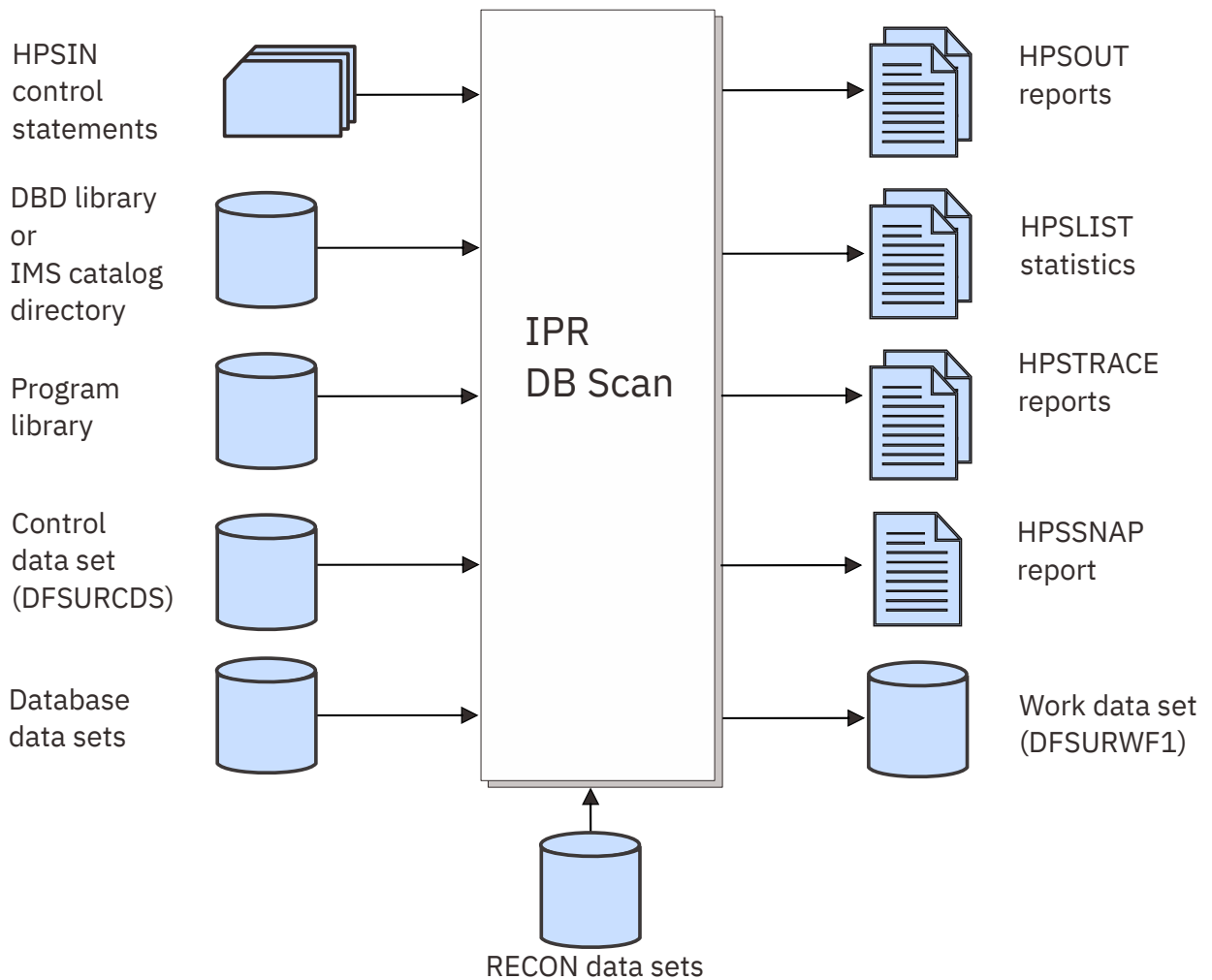

Figure 217. Data flow of the IPR DB Scan utility

## IPR DB Scan restrictions and considerations

The IPR DB Scan utility has certain restrictions.

### Restrictions

The IMS Database Scan utility statements are supported, except for the following:

- CHKPT statement
- RSTRT statement

Unlike the IMS Database Scan utility, you do not need to pad the DBD name or the segment name with blanks even if its length is shorter than 8 bytes.

### Considerations for control statements

Only statements ABEND and DBS are supported in the IPR DB Scan utility. Statements CHKP and RSTRT are not supported.

---

## Chapter 40. IPR DB Scan JCL requirements

To use the IPR DB Scan utility, supply an EXEC statement with PARM parameters, and appropriate DD statements.

### EXEC statement

The EXEC statement for the IPR DB Scan utility must be in the following format:

```
//stepname EXEC PGM=HPSCMAIN,PARM='FUNC=SN'
```

Specify HPSCMAIN as the program name. The PARM= parameter must include the following:

#### **FUNC=SN**

Invokes the IPR DB Scan utility to scan the database. This parameter is required.

Optionally, you can specify the following keywords to specify the job step environment:

#### **DBRC=x**

Specifies whether the IPR DB Scan utility uses DBRC.

**Y**

DBRC is used.

**N**

DBRC is not used until the DBRC=FORCE option is specified during IMS system generation.

If this parameter is not specified, the default setting determined by IMS system generation is used.

#### **IMSPLEX=name**

Specifies the IMSplex name that is to be used by IMS DBRC SCI Registration. This parameter is 1- to 5-characters.

#### **DBRCGRP=ccc**

Specifies the DBRC group identifier that is to be used by IMS DBRC SCI Registration. This parameter is three characters.

#### **SWAP=x**

Makes the address space swappable or non-swappable.

**Y**

The address space is made swappable.

**N**

The address space is made non-swappable.

The default is N.

#### **IRLM=x**

Specifies whether the IPR Unload utility uses IRLM.

**Y**

IRLM is used.

**Note:** Even if IRLM=Y is specified, no locking support through IRLM is available for the internal HSSR calls that are issued to read the database. IRLM is used only for the internal DL/I calls.

**N**

IRLM is not used.

If this parameter is not specified, the default setting determined by the IMS system generation is used.

#### **IRLMNM=name**

If IRLM=Y is specified, this parameter specifies the IRLM subsystem name (a 1-to-4-character alphanumeric name).

**GSGNAME=name**

Specifies the name of the global service group (GSG).

**DFSDF=ccc**

Specifies the 3-character suffix of the DFSDFxxx member of the IMS.PROCLIB data set. You must also specify the PROCLIB DD statement.

**DD statements**

The following table summarizes the DD statements for the IPR DB Scan utility. The descriptions of each DD statement follow the table.

*Table 86. DD statements and record format for the IPR DB Scan utility*

<b>DDNAME</b>	<b>Use</b>	<b>Format</b>	<b>Need</b>
STEPLIB	Input		Required
DFSRESLB	Input		Optional (See <a href="#">Note 1</a> )
IMS	Input		Optional
<i>ddname</i>	Input		Optional (See <a href="#">Note 2</a> )
HPSIN	Input	LRECL=80, RECFM=FB	Optional
HPSGCTL	Input	LRECL=800, RECFM=FB	Optional (See <a href="#">Note 3</a> )
PROCLIB	Input		Optional
RECONx	Input		Optional
DFSURCDS	Input		Required
DFSURWF1	Output	LRECL=900, RECFM=VB	Required
HPSOUT	Output	LRECL=81, RECFM=FBA	Required
HPSLIST	Output	LRECL=133, RECFM=FBA	Optional
HPSTRACE	Output	LRECL=133, RECFM=FBA	Optional
HPSSNAP	Output	LRECL=121, RECFM=VBA	Optional
SYSUDUMP	Output	LRECL=133	Optional

**Notes:**

1. If a library concatenated to STEPLIB is not APF-authorized, the DFSRESLB DD statement is required.
2. If you use dynamic allocation, do not use the DD statement for the database data sets.
3. The DD statement is required if the Post-reorganization utility is used for post-reorganization processing.

**STEPLIB DD**

Points to following libraries:

- IMS Database Reorganization Expert load module library (mandatory)
- IMS HP Unload load module library (mandatory)
- IMS RESLIB library (mandatory)
- The load module library that contains user routines (optional)
- The library that contains DFSMDA members for dynamic allocation of data sets (optional)

- The SHKTLOAD library of IMS Tools Base (optional). This library contains the load modules of Autonomics Director.

The IMS HP Unload load module library must be concatenated before the IMS RESLIB library.

This DD statement is required.

**Note:** You do not need to APF-authorize the STEPLIB libraries for the IPR DB Scan utility. However, if the STEPLIB is not authorized, for example, by having unauthorized libraries concatenated, the DFSRESLB DD statement must be specified.

#### **DFSRESLB DD**

Points to an APF-authorized library that contains the IMS SVC modules. For an IPR DB Scan utility job, IMS RESLIB and any data set that is concatenated to it on the DFSRESLB DD statement must be APF-authorized. For details, see the topic that explains how to specify the DFSRESLB DD statement in IMS batch procedures in *IMS System Definition*.

#### **IMS DD**

Describes the library containing the DBDs for the databases to be scanned. This data set must reside on a direct-access device.

This DD statement is required unless the IMS management of ACBs is enabled. When the IMS management of ACBs is enabled, IMS system ignores the IMS DD statement.

#### **ddname DD**

These DD statements define the database data set to be processed. One statement of this type must be present for each data set of the databases to be scanned. The value of ddname must match the ddname in the DBD.

For a HIDAM database, DD statements must also exist for the data sets that represent the index. The DD statements that specify the index must contain ddnames specified in the DBD for the index database. No DD statements are required for whatever secondary indexes that are associated with this database.

You must not code DCB=BUFNO=*n* or AMP='BUFND=*n*' options to request access method buffers for database data sets; HSSR Engine allocates its own buffer pool for each data set group.

**Note:** If you use dynamic allocation, do not use the DD statement for the database data sets.

#### **HPSIN DD**

Defines an optional data set that contains the control statements specifying the optional functions of the IPR DB Scan utility. For details, see [Chapter 41, “IPR DB Scan control statements,” on page 591](#).

#### **HPSGCTL DD**

Defines the control data set that contains the data generated by the Pre-reorganization utility. This DD statement must be specified if the Post-reorganization utility is used for post-reorganization processing. This data set must reside on a direct-access device.

#### **PROCLIB DD**

Points to the IMS.PROCLIB data set. If DFSDF=*ccc* is specified on the EXEC statement, you must specify this DD statement and ensure that the DFSDF*ccc* member exists in the IMS.PROCLIB data set.

#### **RECONx DD**

This statement provides RECON1, RECON2, and RECON3 DD statement under the same conditions as for standard IMS jobs. If you want to allocate the RECON data sets dynamically, do not specify these DD statements.

IBM recommends that you allocate these data sets dynamically.

#### **DFSURCDS DD**

Defines the output control data set generated by the IMS Database Preorganization utility. The data set must reside on either a tape or a direct-access device.

This DD statement is required.

**DFSURWF1 DD**

Defines the data set is to be supplied as one of the inputs to the IMS Prefix Resolution utility. The data set can reside on either a tape or a direct-access device. DCB parameters specified within this program are RECFM=VB and LRECL=900. BLKSIZE must be specified in this DD statement. If BLKSIZE is not specified, there is no BLKSIZE default, and the results are unpredictable.

This DD statement is required.

**HPSOUT DD**

Defines the main output data set for reports and statistics. The data set can reside on a tape, a direct-access device, or it can be routed through the output stream. For details, see [Chapter 43, "IPR DB Scan reports,"](#) on page 601.

**HPSLIST DD**

Defines the optional output data set in which the statistics produced by HSSR Engine is written. The data set can reside on a tape, a direct-access device, or it can be routed through the output stream. For details, see [Chapter 43, "IPR DB Scan reports,"](#) on page 601.

**HPSTRACE DD**

Defines a trace output data set. It is required whenever either of the following options is activated by the HPSIN control statements: DIAGG=YES or TRACE. The data set can reside on either a tape or a direct-access device, or it can be routed through the output stream. For details, see [Chapter 43, "IPR DB Scan reports,"](#) on page 601.

**HPSSNAP DD**

This required statement defines the output data set on which snapshots of control blocks of HSSR Engine are written when an error occurs during the initialization of HSSR Engine. The data set can reside on either a tape or a direct-access device, or it can be routed through the output stream. For details, see [Chapter 43, "IPR DB Scan reports,"](#) on page 601.

**SYSUDUMP DD**

Defines a dump data set. Most errors end the program by issuing an ABEND macro with the DUMP operand. If you specify ABEND=YES, a storage dump is written in this data set, and the job ends with a return code of 4 or higher.

---

## Chapter 41. IPR DB Scan control statements

The control statements for the IPR DB Scan utility are specified in the HPSIN data set.

For information of the general syntax of control statements, see [“Syntax for the IPR Unload control statements” on page 367](#).

There are two categories of control statements:

- Control statements for DB Scan function
- Control statements for HSSR Engine

The following control statements are provided to control DB Scan function and outputs:

- ABEND
- ADDBGRP
- ADXCFGRP
- DBS
- LOGREL
- OUTREC
- PROGMON

For information about these control statements, see [“Overview of IPR DB Scan control statements” on page 592](#).

The following control statements can be used to control HSSR Engine:

- BUFFERS
- BUFSTAT
- CABBASE
- COMPAREDLI
- COMPAUTH
- DIAGG
- TRACE

**Note:** The IPR DB Scan utility always uses BYINDEX=NO, KEYCHECK=GG, and SKIPERROR=1. These options cannot be changed.

For the description of these control statements, see [“Control statements for HSSR Engine” on page 389](#). Only the keyword \*ALL is allowed for the first parameter of the BUFFERS control statement; you can neither specify a particular database nor a particular ddname. If a BUFFERS= control statement is specified, the IPR DB Scan utility applies it for all databases.

### Topics:

- [“Overview of IPR DB Scan control statements” on page 592](#)
- [“ABEND control statement” on page 592](#)
- [“ADDBGRP control statement” on page 593](#)
- [“ADXCFGRP control statement” on page 593](#)
- [“DBS control statement” on page 593](#)
- [“LOGREL control statement” on page 594](#)
- [“OUTREC control statement” on page 594](#)
- [“PROGMON control statement” on page 595](#)

## Overview of IPR DB Scan control statements

In this topic, the HPSIN control statements used for controlling DB Scan function are described.

The following table shows control statements that can be coded to control the DB Scan function.

Table 87. Control statements for the DB Scan function

Keyword	Acceptable values	Default	Description
ABEND	YES or NO	NO	Requests the storage dump. See <a href="#">“ABEND control statement” on page 592.</a>
ADDBGRP	<i>dbgrpname</i> or *NO	*NO	Specifies the database group name defined in Autonomics Director. See <a href="#">“ADDBGRP control statement” on page 593.</a>
ADXCGRP	<i>xcgrpname</i> or *NO	*NO	Specifies the XCF group name of the Autonomics Director server. See <a href="#">“ADXCGRP control statement” on page 593.</a>
DBS	<i>dbdname, segmname, option</i>	(No default)	Specifies the database (and optionally the segment) to be scanned and the method of the database scan. See <a href="#">“DBS control statement” on page 593.</a>
LOGREL	YES or NO	NO	Specifies whether to generate the Logical Relationship Summary report. See <a href="#">“LOGREL control statement” on page 594.</a>
OUTREC	YES or NO	NO	Specifies whether to generate the Output Record Summary report. See <a href="#">“OUTREC control statement” on page 594.</a>
PROGMON	0-999999	0	Specifies whether to issue a progress monitoring message. See <a href="#">“PROGMON control statement” on page 595.</a>

### ABEND control statement

This control statement requests the storage dump.

This control statement is optional. The default is ABEND=NO.



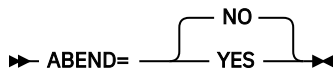

## NO

No storage dump is written.

## YES

If the job ends with a return code of 4 or higher, the IPR DB Scan utility ends this job with an abend code U3999 and writes the storage dump to the SYSUDUMP data set.

## ADDBGRP control statement

---

Specifies the database group name to be sent with the system notification to Autonomics Director.

**Requirement:** An Autonomics Director server must be configured and active. For more information, see the *IMS Tools Base Autonomics Director User's Guide and Reference*.

This control statement is used when `ADXCFCGRP=xcfggrpname` is also specified.

`dbgrpname` is a 1- to 8-alphanumeric character string. The default is `ADDBGRP=*NO`.

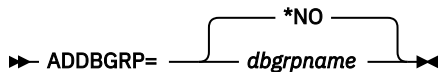

## ADXCFCGRP control statement

---

Specifies the XCF group name of the Autonomics Director server. When IMS Database Reorganization Expert utility processing ends, the utility sends the results with system notification to the specified Autonomics Director server.

If an error occurs in the initialization process of the utility, system notification is not sent to Autonomics Director.

`xcfggrpname` is a 1- to 8-alphanumeric character string. This control statement is optional. The default is `ADXCFCGRP=*NO`.

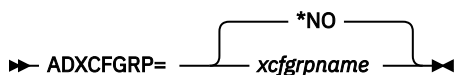

To specify `ADXCFCGRP=xcfggrpname`, the following requirements must be satisfied:

- IMS Database Solution Pack or IMS Database Utility Solution is installed.
- An Autonomics Director server must be configured and active. For more information, see the *IMS Tools Base Autonomics Director User's Guide and Reference*.
- The SHKTLOAD library of IBM IMS Tools Base for z/OS is specified in the STEPLIB concatenations.
- DBRC is active. If DBRC is not active, the `ADXCFCGRP` control statement is ignored.

## DBS control statement

---

This control statement specifies the database (and optionally the segment) to be scanned and the method of the database scan.

This control statement is optional. If you do not specify this control statement, the IPR DB Scan utility uses the information in the DFSURCD5 data set that is created by the IMS Database Preorganization utility to determine which databases to scan.

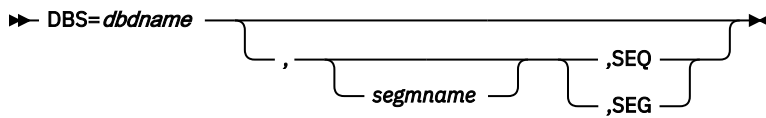

**database-name**

Specifies the database to be scanned. This database must be defined as the scanned database in the DFSURCDS data set. The database name must not exceed eight characters. This parameter is required.

**segment-name**

Specifies the segment to be scanned. The segment name must be defined as the scanned segment in the DFSURCDS data set. The segment name must not exceed eight characters. This parameter is optional. If this parameter is omitted, the IPR DB Scan utility scans all segments that satisfy the following conditions:

- Segments defined in the DFSURCDS data set.
- Segments in the specified database that have logical relationships with other databases.

**SEQ or SEG**

Specifies the method of database scan. This parameter is optional. If this parameter is omitted, SEG is selected for HD databases and SEQ is selected for HISAM databases as the default.

**SEQ**

Scans the database using unqualified GN calls.

**SEG**

Scans the database using GN calls qualified by segment names.

The following figure shows examples of DBS statements:

```
DBS=DBD1 ,SEGM1
DBS=DBD1 , ,SEG
DBS=DBD1 ,SEGM1 ,SEQ
```

## LOGREL control statement

This control statement specifies if you want to generate the Logical Relationship Summary report in the HPSOUT data set.

This control statement is optional. The default is LOGREL=NO.

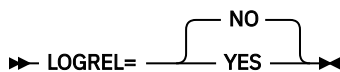

**NO**

Does not generate the report in the HPSOUT data set.

**YES**

Generates the report in the HPSOUT data set.

If this control statement is specified, it is applied to all databases; you cannot specify a particular database for this statement. If more than one LOGREL control statement is specified, only the last statement becomes effective.

## OUTREC control statement

This control statement specifies if you want to generate the Output Record Summary report in the HPSOUT data set.

This control statement is optional. The default is OUTREC=NO.

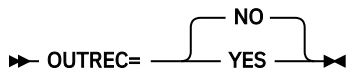

**NO**

Does not generate the report in the HPSOUT data set.

**YES**

Generates the report in the HPSOUT data set.

If this control statement is specified, it is applied to all databases; you cannot specify a particular database for this statement. If more than one OUTREC control statement is specified, only the last statement becomes effective.

## PROGMON control statement

---

This control statement specifies whether the IPR DB Scan utility issues a progress monitoring message at the specified intervals.

This control statement is optional. The default is PROGMON=0 (that is, no progress monitoring message is issued).

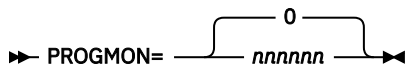

***nnnnnn***

Specifies a left-aligned decimal number in the range of 0 - 999999. After every *nnnnnn* database records are processed, the IPR DB Scan utility issues a progress monitoring message.



## Chapter 42. IPR DB Scan JCL examples

The following topics introduce example JCL streams for using the IPR DB Scan utility.

### Topics:

- [“IPR DB Scan example: Case 1” on page 597](#)
- [“IPR DB Scan example: Case 2” on page 597](#)
- [“IPR DB Scan example: Case 3” on page 598](#)
- [“IPR DB Scan example: Case 4” on page 598](#)

### IPR DB Scan example: Case 1

This topic provides a JCL example for scanning all databases defined in the DFSURCDS data set.

In this case, you do not specify the HPSIN DD statement unless you want to specify the ABEND= statement or the control statements for HSSR Engine. The DBS statement is not required.

```
//HPRDBS EXEC PGM=HPSCMAIN,  
// PARM=' FUNC=SN,DBRC=Y,IRLM=N'  
//STEPLIB DD DISP=SHR,DSN=HPS.SHPSLMDO  
// DD DISP=SHR,DSN=IMS.RESLIB  
// DD DISP=SHR,DSN=IMS.DYNALIB  
//DFSRESLB DD DISP=SHR,DSN=IMS.RESLIB  
//IMS DD DISP=SHR,DSN=IMS.DBDLIB  
//HPSOUT DD SYSOUT=*  
//DFSURWF1 DD DISP=(NEW,CATLG,DELETE),DSN=HPDBS.WF1,  
// UNIT=3390,SPACE=(CYL,(5,1)),  
// DCB=(RECFM=VB,LRECL=900,BLKSIZE=1800)  
//DFSURCDS DD DISP=SHR,DSN=HPDBS.CDS  
//HPSSNAP DD SYSOUT=*  
//SYSUDUMP DD SYSOUT=*
```

Figure 218. Sample JCL stream of the IPR DB Scan utility (case 1)

### IPR DB Scan example: Case 2

This topic provides a JCL example for scanning only some of the databases defined in the DFSURCDS data set.

In this case, you specify which databases are to be scanned with the DBS control statement in the HPSIN data set.

```
//HPRDBS EXEC PGM=HPSCMAIN,  
// PARM=' FUNC=SN,DBRC=Y,IRLM=N'  
//STEPLIB DD DISP=SHR,DSN=HPS.SHPSLMDO  
// DD DISP=SHR,DSN=IMS.RESLIB  
// DD DISP=SHR,DSN=IMS.DYNALIB  
//DFSRESLB DD DISP=SHR,DSN=IMS.RESLIB  
//IMS DD DISP=SHR,DSN=IMS.DBDLIB  
//HPSOUT DD SYSOUT=*  
//DFSURWF1 DD DISP=(NEW,CATLG,DELETE),DSN=HPDBS.WF1,  
// UNIT=3390,SPACE=(CYL,(5,1)),  
// DCB=(RECFM=VB,LRECL=900,BLKSIZE=1800)  
//DFSURCDS DD DISP=SHR,DSN=HPDBS.CDS  
//HPSSNAP DD SYSOUT=*  
//SYSUDUMP DD SYSOUT=*  
//HPSIN DD *  
DBS=SAMPDB01  
/*
```

Figure 219. Sample JCL stream of the IPR DB Scan utility (case 2)

## IPR DB Scan example: Case 3

This is an example to scan a database in an IMS-managed ACBs environment.

When IMS management of ACBs is enabled, you can scan a database without the IMS DD statement.

```
//HPRDBS EXEC PGM=HPSCMAIN,  
// PARM=' FUNC=SN,DBRC=Y,IRLM=N,DFSDFCAT'  
//STEPLIB DD DISP=SHR,DSN=HPS.SHPSLMDO  
// DD DISP=SHR,DSN=IMS.SDFSRESL  
// DD DISP=SHR,DSN=IMS.DYNALIB  
//DFSRESLB DD DISP=SHR,DSN=IMS.SDFSRESL  
//PROCLIB DD DISP=SHR,DSN=IMS.PROCLIB  
//HPSOUT DD SYSOUT=*  
//DFSURWF1 DD DISP=(NEW,CATLG,DELETE),DSN=HPDBS.WF1,  
// UNIT=3390,SPACE=(CYL,(5,1)),  
// DCB=(RECFM=VB,LRECL=900,BLKSIZE=1800)  
//DFSURCDS DD DISP=SHR,DSN=HPDBS.CDS  
//HPSSNAP DD SYSOUT=*  
//SYSUDUMP DD SYSOUT=*  
//HPSIN DD *  
DBS=dbdname  
/*
```

Figure 220. Sample JCL stream to scan a database in an IMS-managed ACBs environment

DFSDFCAT parameter is specified on the EXEC statement. This parameter specifies the DFSDFCAT member that enables IMS-managed ACBs.

The name of the IMS.PROCLIB data set in which the DFSDFCAT member exists is specified on the PROCLIB DD statement.

The name of the DBD to be scanned must be specified on the HPSIN DD statement in an IMS-managed ACBs environment.

You must allocate the catalog partition definition data set when scanning a database with DBRC=NO. To do so, add the DFSHDBSC DD statement or the DFSMDA member with the TYPE=CATDBDEF statement.

## IPR DB Scan example: Case 4

This is an example to scan a database an IMS-managed ACBs environment with the IMS Catalog Definition exit routine (DFS3CDX0).

When IMS management of ACBs is enabled, you can scan a database without the IMS DD statement.

```
//HPRDBS EXEC PGM=HPSCMAIN,  
// PARM=' FUNC=SN,DBRC=Y,IRLM=N'  
//STEPLIB DD DISP=SHR,DSN=HPS.SHPSLMDO  
// DD DISP=SHR,DSN=IMS.SDFSRESL  
// DD DISP=SHR,DSN=IMS.DYNALIB  
//DFSRESLB DD DISP=SHR,DSN=IMS.SDFSRESL  
//PROCLIB DD DISP=SHR,DSN=IMS.PROCLIB  
//HPSOUT DD SYSOUT=*  
//DFSURWF1 DD DISP=(NEW,CATLG,DELETE),DSN=HPDBS.WF1,  
// UNIT=3390,SPACE=(CYL,(5,1)),  
// DCB=(RECFM=VB,LRECL=900,BLKSIZE=1800)  
//DFSURCDS DD DISP=SHR,DSN=HPDBS.CDS  
//HPSSNAP DD SYSOUT=*  
//SYSUDUMP DD SYSOUT=*  
//HPSIN DD *  
DBS=dbdname  
/*
```

Figure 221. Sample JCL stream to scan a database with DFS3CDX0 exit routine

The DFS3CDX0 exit routine must be bound to IMS.SDFSRESL or a concatenated library.

The name of the DBD to be scanned must be specified on the HPSIN DD statement in an IMS-managed ACBs environment.

You must allocate the catalog partition definition data set when scanning a database with DBRC=NO. To do so, add the DFSHDBSC DD statement or the DFSMDA member with the TYPE=CATDBDEF statement.





---

## Chapter 43. IPR DB Scan reports

The IPR DB Scan utility produces the reports and statistics in the following data sets.

- HPSOUT data set
- HPSLIST data set

The following reports are written in the HPSOUT data set:

- HPSIN Control Statements report
- Logical Relationship Summary report (if LOGREL=YES is specified.)
- Output Record Summary report (if OUTREC=YES is specified)
- Buffering and I/O Statistics report

The HPSLIST data set contains the report and statistics produced by HSSR Engine. The following reports are written in the data set:

- DB Call Statistics report
- CAB Statistics report

**Note:** CAB (Chained Anticipatory Buffering) is the name of the buffering method provided by the buffer handler of HSSR Engine.

The reports and statistics produced in the HPSLIST data set are intended to be used for the purpose of tuning HSSR Engine or for the problem determination. These reports are same as those written in the HSSRSTAT data set of IMS HP Unload. For details of the reports, see the *IMS High Performance Unload User's Guide*.

For the purpose of problem determination, the following data sets are also provided:

- HPSTRACE data set
- HPSSNAP data set

The HPSTRACE data set contains the trace information and diagnostics information for GG status codes. The following trace reports are produced in the data set:

- HSSR Trace Output report
- HSSR Trace Output report with diagnostics

These trace reports are same as those written in the HSSRTRAC data set of IMS HP Unload. For details of the reports, see the *IMS High Performance Unload User's Guide*.

If any abnormality is detected during the initialization of HSSR Engine, the snapshot of HSSR Engine control blocks is dumped into the HPSSNAP data set. The data set might be needed by IBM to analyze a problem. The content of the data set is the same as that of the HSSRSNAP data set of IMS HP Unload. For details, see the *IMS High Performance Unload User's Guide*.

For other output data sets, see [Chapter 40, "IPR DB Scan JCL requirements," on page 587](#).

### Topics:

- ["HPSIN Control Statements report" on page 602](#)
- ["Logical Relationship Summary report" on page 602](#)
- ["Output Record Summary report" on page 605](#)
- ["Buffering and I/O Statistics report" on page 606](#)

## HPSIN Control Statements report

This report contains an echo back of the control statements you specified in the HPSIN data set. You can check the parameters used by the IPR DB Scan utility for this job step run.

The following figure shows an example of the HPSIN Control Statements report.

```
IMS HIGH PERFORMANCE UNLOAD                                PAGE:      1
5655-E06                                                    11/01/2023 15.26.08

                        "HPSIN CONTROL STATEMENTS"

0.....1.....2.....3.....4.....5.....6.....7.....8
1234567890123456789012345678901234567890123456789012345678901234567890
OUTREC=YES
LOGREL=YES

"RUN TIME OPTIONS FOR THIS EXECUTION"

OPTIONS FOR SCAN FUNCTION:

KEYWORD      VALUE
-----
ABEND        NO
ADDBGRP      N/A (THIS OPTION IS IGNORED WHEN ADXCFGRP=*NO)
ADXCFCGRP    *NO
LOGREL       YES
OUTREC       YES
PROGMON      0

OPTIONS FOR HSSR ENGINE:

KEYWORD      VALUE
-----
BUFFERS      *ALL, ,8, ,100, YES, YES
BUFSTAT      NO
CABBASE      1, OSAM, SEQ
CABBASE      2, OSAM, DIR
CABBASE      8, VSAM, SEQ
CABBASE      15, VSAM, DIR
COMPAUTH     NO
ZIIPMODE     NEVER

OPTIONS FOR DIAGNOSIS:

KEYWORD      VALUE
-----
COMPAREDLI   NO
DIAGG        NO
RAPCHECK     NO
TRACE        (NONE)
```

Figure 222. HPSIN Control Statements report for the IPR DB Scan utility

## Logical Relationship Summary report

The Logical Relationship Summary report shows the contents of the DFSURCDs data set, which is input to the IPR DB Scan utility.

The following figure shows an example of the Logical Relationship Summary report.

"LOGICAL RELATIONSHIP SUMMARY"

\*\* INITIALLY LOADED DB: HDAMDB2 \*\* --(A)

RELATIONSHIP DATA

LOGICAL PARENT:			LOGICAL CHILD:		
DBDNAME	SEGNAME	DDNAME (PRIME/OFLW)	DBDNAME	SEGNAME	DDNAME (PRIME/OFLW)
HDAMDB1	LPSEGM1	HDAMDS1	HDAMDB2	LCSEGM1	HDAMDS2

RECORD COUNTS

INPUT SEGMENT:		OUTPUT RECORD:	
SEGMENT TYPE	COUNTS	SEGMENT TYPE	COUNTS
LOGICAL PARENTS	1,000,000	LOGICAL PARENTS	1,000,000
LOGICAL CHILDREN	0	LOGICAL CHILDREN	0
		LOGICAL CHILD FIRST	N/A
		LOGICAL CHILD LAST	0
		LOGICAL TWIN FORWARD	0
		LOGICAL TWIN BACKWARD	0
TOTAL	1,000,000	TOTAL	1,000,000

\*\* RELOADED DB: HDAMDB3 \*\* --(B)

RELATIONSHIP DATA

LOGICAL PARENT:			LOGICAL CHILD:		
DBDNAME	SEGNAME	DDNAME (PRIME/OFLW)	DBDNAME	SEGNAME	DDNAME (PRIME/OFLW)
HDAMDB3	LPSEGM2	HDAMDS3A HDAMDS3B HDAMDS3C	HDAMDB4	LCSEGM2	HDAMDS4

RECORD COUNTS

INPUT SEGMENT:		OUTPUT RECORD:	
SEGMENT TYPE	COUNTS	SEGMENT TYPE	COUNTS
LOGICAL PARENTS	0	LOGICAL PARENTS	0
LOGICAL CHILDREN	1,000,000	LOGICAL CHILDREN	1,000,000
		LOGICAL CHILD FIRST	N/A
		LOGICAL CHILD LAST	0
		LOGICAL TWIN FORWARD	200,000
		LOGICAL TWIN BACKWARD	200,000
TOTAL	1,000,000	TOTAL	1,400,000

\*\* RELOADED DB: HDAMDB5 \*\* --(C)

RELATIONSHIP DATA

LOGICAL PARENT:			LOGICAL CHILD:		
DBDNAME	SEGNAME	DDNAME (PRIME/OFLW)	DBDNAME	SEGNAME	DDNAME (PRIME/OFLW)
HDAMDB5	LPSEGM3	HDAMDS1	HDAMDB5	LCSEGM3	HDAMDS4

RECORD COUNTS

INPUT SEGMENT:		OUTPUT RECORD:	
SEGMENT TYPE	COUNTS	SEGMENT TYPE	COUNTS
LOGICAL PARENTS	N/A	LOGICAL PARENTS	N/A
LOGICAL CHILDREN	N/A	LOGICAL CHILDREN	N/A
		LOGICAL CHILD FIRST	N/A
		LOGICAL CHILD LAST	N/A
		LOGICAL TWIN FORWARD	N/A
		LOGICAL TWIN BACKWARD	N/A
TOTAL	N/A	TOTAL	N/A

Figure 223. Logical Relationship Summary report

The items in the Logical Relationship Summary report are described as follows:

### **Report header**

The title of this report is shown at the top of this report.

**\*\* INITIALLY LOADED DB: xxxxxxxx**

**\*\*\*\* RELOADED DB: xxxxxxxx \*\***

The name of the database that is initially loaded or reorganized.

### **RELATIONSHIP DATA**

The DFSURCDS data set information is shown for each logical relationship.

#### **LOGICAL PARENT**

##### **DBDNAME**

DBD name of the logical parent.

##### **SEGNAME**

Segment name of the logical parent.

##### **DDNAME**

The ddname of the logical parent. For a partitioned database, all ddnames are shown. For a multiple data set group, the ddname that contains the logical parent segment is shown. For a HISAM database, the ddname is shown in the form of primary/overflow.

#### **LOGICAL CHILD**

##### **DBDNAME**

DBD name of the logical child.

##### **SEGNAME**

Segment name of the logical child.

##### **DDNAME**

The ddname of the logical child. For a partitioned database, all ddnames are shown. For a multiple data set group, the ddname that contains the logical child segment is shown. For a HISAM database, the ddname is shown in the form of primary/overflow.

**Note:** Relationship data is shown for each logical relationship to be scanned in the DFSURCDS data set. This information is generated even if a logical relationship is not actually scanned. If a logical parent has more than one logical child, the relationship data is shown for each logical child.

### **RECORD COUNTS**

The number of scanned segments and the number of records written in DFSURWF1 are shown for each logical relationship.

#### **INPUT SEGMENT**

##### **LOGICAL PARENTS**

The number of logical parent segments that were scanned.

##### **LOGICAL CHILDREN**

The number of logical child segments that were scanned.

##### **TOTAL**

The total number of segments that were scanned.

#### **OUTPUT RECORD**

##### **LOGICAL PARENTS**

The number of logical parent records (TYPE00 records) written in DFSURWF1.

##### **LOGICAL CHILDREN**

The number of logical child records (TYPE10 records) written in DFSURWF1.

##### **LOGICAL CHILD FIRST**

N/A is always shown on this column because this type of record is never written in DFSURWF1.

##### **LOGICAL CHILD LAST**

The number of logical records (TYPE02 records) written in DFSURWF1. The TYPE02 record means a logical child segment with LTF=0—that is, the last segment in the twin chain.

**LOGICAL TWIN FORWARD**

The number of logical records (TYPE20 records) written in DFSURWF1. The TYPE20 record means a logical child segment with LTF.

**LOGICAL TWIN BACKWARD**

The number of logical records (TYPE30 records) written in DFSURWF1. The TYPE30 record means a logical child segment with LTB.

**TOTAL**

The total number of records written in DFSURWF1.

**Note:** The record counts information is shown only if a logical relationship shown under RELATIONSHIP DATA is actually scanned. If not, N/A is shown on the COUNTS column.

The report shown in [Figure 223 on page 603](#) consists of three types of information, which is shown as (A), (B), and (C).

**(A)**

Because the database HDAMDB2 is initially loaded, an existing database HDAMDB1, which has a logical relationship with HDAMDB2, is scanned. As the result of the scan, 1,000,000 LPSEGM1 of HDAMDB1 was scanned and 1,000,000 output records were generated.

**(B)**

HDAMDB3 and HDAMDB4 have a logical relationship. HDAMDB4 is scanned because HDAMDB3 is reorganized. As the result of the scan, 1,000,000 LCSEGM2 of HDAMDB4 was scanned and 1,400,000 output records were generated. HDAMDB3, which contains a logical parent segment, is a partitioned database.

**(C)**

HDAMDB5 and HDAMDB6 have a logical relationship. Although HDAMDB5 is reorganized, HDAMDB6 was not scanned because of the user specification.

## Output Record Summary report

---

The Output Record Summary report provides information about the DFSURWF1 data set, which is an output of the IPR DB Scan utility.

The following figure shows an example of the Output Record Summary report.

```

IMS HIGH PERFORMANCE UNLOAD                                PAGE:          1
5655-E06                                                    10/05/2023  15.28.15

                "OUTPUT RECORD SUMMARY"

OUTPUT RECORD SUMMARY

OUTPUT DDNAME: DFSURWF1
OUTPUT DSNAME: HPR001.HPR110.HPSDBS.DFSURWF1

SCANNED:   OUTPUT RECORD:   SCANNED:   OUTPUT RECORD:
DBDNAME    COUNTS           DBDNAME    COUNTS
-----
HDAMDB1    1,000,000
HDAMDB4    1,400,000

TOTAL OUTPUT RECORD = 2,400,000

```

*Figure 224. Output Record Summary report*

The following information is generated in the Output Record Summary report:

**OUTPUT DDNAME**

Indicates the output ddname, which is always DFSURWF1.

**OUTPUT DSNAME**

Indicates the output data set name.

**SCANNED**

The DBD information about the scanned database.

**DBDNAME**

The DBD name of the scanned database.

**OUTPUT RECORD**

The information about the output records.

**COUNTS**

The number of output records.

## Buffering and I/O Statistics report

---

This report contains statistics on I/O and buffer handler activities.

The report format is the same as that for the IPR Unload utility, which is shown in [“Buffering and I/O Statistics report”](#) on page 447.

---

## Part 8. Reference

The following topics provide additional information for using IMS Database Reorganization Expert.

**Topics:**

- [Chapter 44, “Performance tips and considerations,” on page 609](#)
- [Chapter 45, “Setting installation default options,” on page 617](#)
- [Chapter 46, “Database tuning guide,” on page 629](#)
- [Chapter 47, “How to read syntax diagrams,” on page 651](#)





---

## Chapter 44. Performance tips and considerations

Use the following topics to learn the techniques for improving the performance of utilities that IMS Database Reorganization Expert provides.

### Topics:

- [“Performance tips for the Smart Reorg utility” on page 609](#)
- [“Performance tips for the IPR Unload utility” on page 612](#)
- [“Performance tips for the IPR Reload utility” on page 614](#)

---

### Performance tips for the Smart Reorg utility

Use the following techniques to improve the performance of Smart Reorg utility jobs.

**Tip:** Many of the control statements and their values introduced in this topic can be set in the Installation Default Option Table (HPSCOPTI) so that the control statement values are always applied.

- To learn more about the Installation Default Option Table, see [Chapter 45, “Setting installation default options,” on page 617](#).
- For a JCL example to set these values in HPSCOPTI, see [“Example: Changing default values to achieve best performance \(Smart Reorg, IPR Unload, IPR Reload\)” on page 626](#).

If you used the IMS Tools Setup to customize your tools, you can refer to the generated customization JCL for your specific environment in *your.hlq.CUSTJCL(#A6GBLRX)*.

#### High Performance I/O Driver

You can reduce the elapsed time and the CPU usage by using the High Performance I/O Driver in the Reload task and the image copy task.

If all the libraries that are concatenated in the STEPLIB are APF-authorized, the HPIO option (HPIO=YES) is enabled automatically and the High Performance I/O Driver is used during the job.

If the library for IMS DFSMDA members is not APF-authorized, you can add the IMSDALIB DD statement to specify the library.

For more information, see [“HPIO control statement” on page 137](#).

You can set this value in the Installation Default Option Table (HPSCOPTI) so that the value is always applied. Use the following example to specify this value in HPSCOPTI:

```
HPSCOPT DRIVER,HPIO=YES
```

#### zIIP processor

A portion of VSAM ESDS I/O or OSAM LDS I/O workloads can be offloaded to IBM z Integrated Information Processor (zIIP) and reduce the use of the main CPU.

To enable zIIP processing, specify the ZIIPMODE=COND control statement in the (REORG) block of the HPSIN DD statement. Certain conditions must be satisfied to enable zIIP processing. For more information, see [“ZIIPMODE control statement” on page 162](#).

You can set this value in the Installation Default Option Table (HPSCOPTI) so that the value is always applied. Use the following example to specify this value in HPSCOPTI:

```
HPSCOPT DRIVER,ZIIPMODE=COND
```

## High performance data transfer service (IPRPIPE)

IPRPIPE provides a high performance data transfer service between reorganization tasks. In order to avoid timeouts while establishing connection between each task, consider specifying the PIPEWAIT option in the Installation Default Option Table (HPSCOPI).

Use the following example to specify this option in the HPSCOPI:

```
HPSCOPI DRIVER,PIPEWAIT=15
```

For more information, see [“PIPEWAIT control statement”](#) on page 152.

## Suppress printing of statistics reports

You can suppress printing of some statistics reports to reduce CPU usage and improve the performance.

To suppress printing of some reports, specify the STATUL=NO and the STATRL=NO control statements in the (REORG) block of the HPSIN DD statement. For the type of reports that are suppressed, see [“STATUL control statement”](#) on page 160 and [“STATRL control statement”](#) on page 159.

You can set the STATRL value in the Installation Default Option Table (HPSCOPI) so that the value is always applied. Use the following example to specify this option in the HPSCOPI:

```
HPSCOPI DRIVER,STATRL=NO
```

## Exclude the ILDS build process

This tip applies to HALDB that has no logical relationships defined.

If you specify the PSINDEXBLD control statement so that all the PSINDEXes are built in the Smart Reorg job, or if you are planning to build all PSINDEXes by using IMS Index Builder after the Smart Reorg job, the Indirect List data sets (ILDSs) do not need to be built in the Smart Reorg job.

Specify the ILDSBLD control statement in the (REORG) block of the HPSIN DD statement or set this value in the Installation Default Option Table (HPSCOPI) to control the behavior of the ILDS build process.

- ILDSBLD=YES,INITONLY specifies to initialize the ILDSs without creating ILEs (indirect list entries) and, thus, reduces the use of the CPU and the shadow space.
- ILDSBLD=YES,COND specifies that the Smart Reorg job applies the ILDSBLD=YES,INITONLY option only when the HALDB has no logical relationships and all PSINDEXes are to be built by specifying the PSINDEXBLD control statement or by using WFP data sets.

For more information, see [“ILDSBLD control statement”](#) on page 139.

To set this value in the Installation Default Option Table (HPSCOPI) so that the value is always applied, use the following example:

```
HPSCOPI DRIVER,ILDSBLD=(YES,COND)
```

## CAB sequential I/O for OSAM data sets

To improve the performance of CAB sequential I/O for OSAM database data sets, consider specifying the CABBASE\_OS option in the Installation Default Option Table (HPSCOPI). Use the following example to specify this value in HPSCOPI:

```
HPSCOPI DRIVUL,CABBASE_OS=8
```

If you do not want this value in the HPSCOPI, you can specify it in the (UNLOAD) block of the HPSIN DD statement as follows:

```
CABBASE=8,OSAM,SEQ
```

For more information, see [“CABBASE control statement”](#) on page 396.

## Compressed segment data

The DECOMPRESS control statement specifies to call the segment compression routine to decompress all segment types that have COMPRTN specified on their related SEGM statements in the DBD. DECOMPRESS=NO, which is the default, reduces the use of CPU during unload and reload processing because it specifies not to expand segment data that was compressed by a Segment Edit/Compression exit routine.

Specify DECOMPRESS=YES in the (UNLOAD) block of the HPSIN DD statement only if a user exit routine is specified or the Segment Edit/Compression exit routine was changed.

For more information, see [“DECOMPRESS control statement” on page 372.](#)

## I/O performance for (P)HDAM that has many overflow segments

If your HDAM or PHDAM database has many overflow segments and the Smart Reorg utility job uses the High Performance I/O Driver (HPIO option), you can improve the I/O performance further by enabling the OADSPR option. OADSPR=YES specifies to reduce the usage of data space that is required when processing the overflow area.

**Note:** OADSPR=YES is applicable only to HDAM and PHDAM databases. The Smart Reorg utility ignores OADSPR=YES if the database organization is not HDAM or PHDAM.

To enable the OADSPR option, specify OADSPR=YES in the (RELOAD) block of the HPSIN DD statement. For more information, see [“OADSPR control statement” on page 523.](#)

You can also set this value in the Installation Default Option Table (HPSCOPTI) so that the value is always applied. Use the following example to specify this value in HPSCOPTI:

```
HPSCOPT  DRIVRL , OADSPR=YES
```

## Avoid unnecessary sort processing in Reload task

Physical sequential sort processing occurs before reload. You can avoid unnecessary sort processing to reduce elapsed time.

To avoid unnecessary sort processing, specify the SORT=COND control statement in the (RELOAD) block of the HPSIN DD statement. If REORGINPUT=ULDS is specified, the following conditions must be satisfied to enable SORT=COND:

- The input unloaded data set must be created by the IPR Unload utility or IMS HP Unload with the CHECKREC=YES option.
- The format of the unloaded data set must be in HD format or in short header format.

For more information, see [“SORT control statement” on page 528.](#)

You can also set this value in the Installation Default Option Table (HPSCOPTI) so that the value is always applied. Use the following example to specify this value in HPSCOPTI:

```
HPSCOPT  DRIVRL , SORT=COND
```

## Tip to improve Type-A image copy processing

If the database is either HISAM or SHISAM, specify a value greater than 1000 for the DBBUF parameter of the GLOBAL statement in the ICEIN DD.

With Type-A image copy, the DBBUF parameter defines the number of queuing buffers between the reload process and the image copy process, and the default value is 250. Generally the CI size of a HISAM or SHISAM database is small. In such a case, the buffers are used up frequently causing the reload process to suspend until all the data in the buffers is processed by the image copy process. Specifying more than 1000 for the DBBUF parameter increases the number of buffers and prevents performance deterioration.

## Tip to improve Type-B image copy processing

Image Copy processing for database data sets runs in parallel unless IC control statements for database data sets are specified in ICEIN DD. The maximum number of parallel tasks is defined by the TASKCTL parameter and the default is 15. If errors occur due to insufficient storage, specify a value less than 15 for the TASKCTL parameter of the GLOBAL statement in the ICEIN DD to reduce the number of parallel tasks.

**Note:** If APAR PI71145 is not applied to IMS High Performance Image Copy 4.2, the default value for the TASKCTL parameter is 253.

## Examples for modifying HPSCOPTI

You can refer to examples in “[HPSCOPT macro statement examples](#)” on page 625 to modify the Installation Default Option Table (HPSCOPTI).

## Performance tips for the IPR Unload utility

---

Use the following techniques to improve the performance of IPR Unload utility jobs.

Techniques explained in this topic are for improving the performance of IPR Unload utility jobs (EXEC PGM=HPSCMAIN,FUNC='UL') and they are not applicable to the Unload tasks of Smart Reorg utility jobs. For techniques to improve the Unload tasks of Smart Reorg utility jobs, see “[Performance tips for the Smart Reorg utility](#)” on page 609.

**Tip:** Many of the control statements and their values introduced in this topic can be set in the Installation Default Option Table (HPSCOPTI) so that the control statement values are always applied.

- To learn more about the Installation Default Option Table, see [Chapter 45, “Setting installation default options,”](#) on page 617.
- For a JCL example to set these values in HPSCOPTI, see “[Example: Changing default values to achieve best performance \(Smart Reorg, IPR Unload, IPR Reload\)](#)” on page 626.

## Media Manager

Media Manager improves the performance and reduces CPU time required to read VSAM ESDS and OSAM LDS database data sets.

To use Media Manager, APF-authorize all the libraries that are concatenated in the JOBLIB or the STEPLIB. You do not need to specify specific keywords to enable Media Manager.

**Restriction:** Media Manager cannot be used in IPR Unload utility jobs that are invoked by JCL written for IMS HD Reorganization Unload (DFSURGU0).

## zIIP processor

A portion of VSAM ESDS I/O or OSAM LDS I/O workloads can be offloaded to IBM z Integrated Information Processor (zIIP) and reduce the use of the main CPU.

To enable zIIP processing, specify the ZIIPMODE=COND control statement in the HPSIN DD statement. Certain conditions must be satisfied to enable zIIP processing. For more information, see “[ZIIPMODE control statement](#)” on page 404.

You can set this value in the Installation Default Option Table (HPSCOPTI) so that the value is always applied. Use the following example to specify this value in HPSCOPTI:

```
HPSCOPT UNLOAD,ZIIPMODE=COND
```

## CAB sequential I/O for OSAM data sets

You can improve the job performance by tuning the CAB sequential I/O buffer. The CABBASE control statement specified in the HPSIN DD statement is used for tuning the buffer.

- For OSAM database data sets, the following example contains recommended values:

```
CABBASE=8,OSAM,SEQ
```

You can set this value in the Installation Default Option Table (HPSCOPTI) so that the value is always applied. Use the following example to specify this value in HPSCOPTI.

```
HPSCOPT UNLOAD,CABBASE_OS=8
```

**Requirement:** To use the CABBASE control statement, ensure that you have applied APAR PI77308 to IMS Database Reorganization Expert and APAR PI77214 to IMS HP Unload.

- For VSAM data sets, an optimum value is applied by default so you do not need to specify a CABBASE control statement.

## Suppress printing of statistics reports

By default, the IPR Unload utility generates many statistics reports. You can suppress printing of some statistics reports to reduce CPU usage and improve the performance.

To suppress printing of some reports, specify the STATREP=NO control statement in the HPSIN DD statement. For the type of reports that are suppressed, see [“STATREP control statement” on page 386](#).

You can set this value in the Installation Default Option Table (HPSCOPTI) so that the value is always applied. Use the following example to specify this value in HPSCOPTI:

```
HPSCOPT UNLOAD,STATREP=NO
```

## Deactivate segment compression routine

The DECOMPRESS control statement specifies to call the segment compression routine to decompress all segment types that have COMPRTN specified on their related SEGM statements in the DBD. If your IPR Unload utility job calls the segment compression routine, consider deactivating this option.

To deactivate this option, specify the DECOMPRESS=NO control statement in the HPSIN DD statement. DECOMPRESS=NO is the default, so only do this if DECOMPRESS=YES is specified for your job. For more information, see [“DECOMPRESS control statement” on page 372](#).

You can set this value in the Installation Default Option Table (HPSCOPTI) so that the value is always applied. Use the following example to specify this value in HPSCOPTI:

```
HPSCOPT UNLOAD,DECOMPRESS=NO
```

## COBOL user exit

If the user exit routine is written in Enterprise COBOL for z/OS, you can specify the LE (Language Environment) option on the OUTPUT control statement to improve performance. This option indicates that the user exit routine runs in the Language Environment using the CEEPIPI invocation.

**Requirement:** To enable this option, ensure that you have applied APAR PI91820 to IMS HP Unload.

The following examples show how to apply the LE option:

```
//HPSIN DD *
OUTPUT=SYSUT2,,COBEXIT,Y,Y,Y,Y,,,L      (for Type-A user exit)
OUTPUT=SYSUT2,,(COBEXIT,B),L          (for Type-B user exit)
```

For more information, see [“OUTPUT control statement” on page 375](#).

## Examples for modifying HPSCOPTI

You can refer to examples in [“HPSCOPT macro statement examples” on page 625](#) to modify the Installation Default Option Table (HPSCOPTI).

## Performance tips for the IPR Reload utility

Use the following techniques to improve the performance of IPR Reload utility jobs.

Techniques explained in this topic are for improving the performance of IPR Reload utility jobs (EXEC PGM=HPSCMAIN,FUNC='RL') and they are not applicable to the Reload tasks of Smart Reorg utility jobs. For techniques to improve the Reload tasks of Smart Reorg utility jobs, see [“Performance tips for the Smart Reorg utility”](#) on page 609.

**Tip:** Many of the control statements and their values introduced in this topic can be set in the Installation Default Option Table (HPSCOPTI) so that the control statement values are always applied.

- To learn more about the Installation Default Option Table, see [Chapter 45, “Setting installation default options,”](#) on page 617.
- For a JCL example to set these values in HPSCOPTI, see [“Example: Changing default values to achieve best performance \(Smart Reorg, IPR Unload, IPR Reload\)”](#) on page 626.

### I/O performance for (P)HDAM or (P)HIDAM database data sets

To improve the I/O performance for HDAM, PHDAM, HIDAM, or PHIDAM database data sets, enable the High Performance I/O Driver (HPIO option).

**Requirement:** To enable the High Performance I/O Driver, all the libraries concatenated in the STEPLIB must be APF-authorized.

The High Performance I/O Driver can be enabled by specifying HPIO=YES in the HPSIN DD statement. For more information, see [“HPIO control statement”](#) on page 518.

You can set this value in the Installation Default Option Table (HPSCOPTI) so that the value is always applied. Use the following example to specify this value in HPSCOPTI:

```
HPSCOPT RELOAD,HPIO=YES
```

### I/O performance for (P)HDAM that has many overflow segments

If your HDAM or PHDAM database has many overflow segments and your IPR Reload job uses the High Performance I/O Driver (HPIO option), you can improve the I/O performance further by enabling the OADSPR option. The OADSPR option specifies to reduce the usage of data space that is required when processing the overflow area.

To enable the OADSPR option, specify OADSPR=YES in the HPSIN DD statement. For more information, see [“OADSPR control statement”](#) on page 523.

You can set this value in the Installation Default Option Table (HPSCOPTI) so that the value is always applied. Use the following example to specify this value in HPSCOPTI:

```
HPSCOPT RELOAD,OADSPR=YES
```

### zIIP processor

A portion of VSAM ESDS I/O or OSAM LDS I/O workloads can be offloaded to IBM z Integrated Information Processor (zIIP) and reduce the use of the main CPU.

To enable zIIP processing, specify the ZIIPMODE=COND control statement in the HPSIN DD statement. Certain conditions must be satisfied to enable zIIP processing. For more information, see [“ZIIPMODE control statement”](#) on page 536.

You can set this value in the Installation Default Option Table (HPSCOPTI) so that the value is always applied. Use the following example to specify this value in HPSCOPTI:

```
HPSCOPT RELOAD,ZIIPMODE=COND
```

## Avoid unnecessary sort processing

Physical sequential sort processing occurs before reload. You can avoid unnecessary sort processing to reduce elapsed time.

To avoid unnecessary sort processing, specify the SORT=COND control statement in the HPSIN DD statement.

**Requirement:** The following conditions must be satisfied to enable SORT=COND:

- The input unloaded data set must be created by the IPR Unload utility or IMS HP Unload with the CHECKREC=YES option.
- The format of the unloaded data set must be in HD format or in short header format.

For more information, see [“SORT control statement”](#) on page 528.

You can set this value in the Installation Default Option Table (HPSCOPTI) so that the value is always applied. Use the following example to specify this value in HPSCOPTI:

```
HPSCOPT RELOAD, SORT=COND
```

## Exclude the ILDS build process

This tip applies to HALDB that has no logical relationships defined.

If you are planning to build all PSINDEXes by using IMS Index Builder, the Indirect List data sets (ILDSs) do not need to be built in the IPR Reload job.

Specify the ILDSBLD control statement in the HPSIN DD statement or set this value in the Installation Default Option Table (HPSCOPTI) to control the behavior of the ILDS build process.

- ILDSBLD=YES,INITONLY specifies to initialize the ILDSs without creating ILEs (indirect list entries) and, thus, reduces the use of the CPU and the disk space.
- ILDSBLD=YES,COND specifies that the IPR Reload utility applies the ILDSBLD=YES,INITONLY option only when the HALDB has no logical relationships and all PSINDEXes are to be built by using WFP data sets.

For more information, see [“ILDSBLD control statement”](#) on page 518.

To set this value in the Installation Default Option Table (HPSCOPTI) so that the value is always applied, use the following example:

```
HPSCOPT RELOAD, ILDSBLD=(YES, COND)
```

## Tips to improve the performance of subsequent utility jobs

### Reduce elapsed time for IMS Index Builder job (HALDB with PSINDEX)

If you specify the WFPHLQ control statement in the HPSIN DD statement, the IPR Reload utility generates WFP work data sets. These data sets can be used as input to IMS Index Builder jobs to rebuild indexes without scanning the databases. You can also specify the WFPSPACE, WFPUNIT, WFPVOL, and WFPVOLCNT control statements in the HPSIN DD statement to set attributes for dynamic allocation of WFP data sets.

For more information, see the following topics:

- [“WFPHLQ control statement”](#) on page 534
- [“WFPSPACE control statement”](#) on page 535
- [“WFPUNIT control statement”](#) on page 535
- [“WFPVOL control statement”](#) on page 535
- [“WFPVOLCNT control statement”](#) on page 536

### **Reduce elapsed time for utility jobs that resolve secondary indexes and logical relationships**

If a non-HALDB has both secondary index and logical relationships, consider specifying the HPSRSIDX DD statement. This DD statement separates DFSURWF1 records for secondary indexes from DFSURWF1 records for logical relationships. The use of these DFSURWF1 records increases the performance of utility jobs that resolves secondary indexes and logical relationships.

DFSURWF1 records can be used by the following utilities:

- IMS Index Builder
- IMS HP Prefix Resolution
- IMS Database Prefix Resolution utility

For more information about HPSRSIDX DD and DFSURWF1 DD, see [Chapter 34, “IPR Reload JCL requirements,”](#) on page 491.

### **Examples for modifying HPSCOPTI**

You can refer to examples in [“HPSCOPT macro statement examples”](#) on page 625 to modify the Installation Default Option Table (HPSCOPTI).



---

## Chapter 45. Setting installation default options

You can change the default values for some options by creating an Installation Default Option Table (HPSCOPTI) for your site.

The following topics contain product-sensitive programming interface information. To understand the restrictions associated with this type of material, see [“Programming interface information”](#) on page 804.

### Topics:

- [“How runtime options are determined”](#) on page 617
- [“Creating an Installation Default Option Table \(HPSCOPTI\)”](#) on page 617
- [“HPSCOPTG sample JCL stream”](#) on page 618
- [“How to code HPSCOPT macro statements”](#) on page 618
- [“HPSCOPT macro statement examples”](#) on page 625

---

### How runtime options are determined

This topic discusses how the runtime options are determined.

PSPI

The following figure illustrates how the values of the runtime options are determined. The sources that determine those values are placed in order of priority; that is, an option in a higher position in the figure overrides one in a lower position.

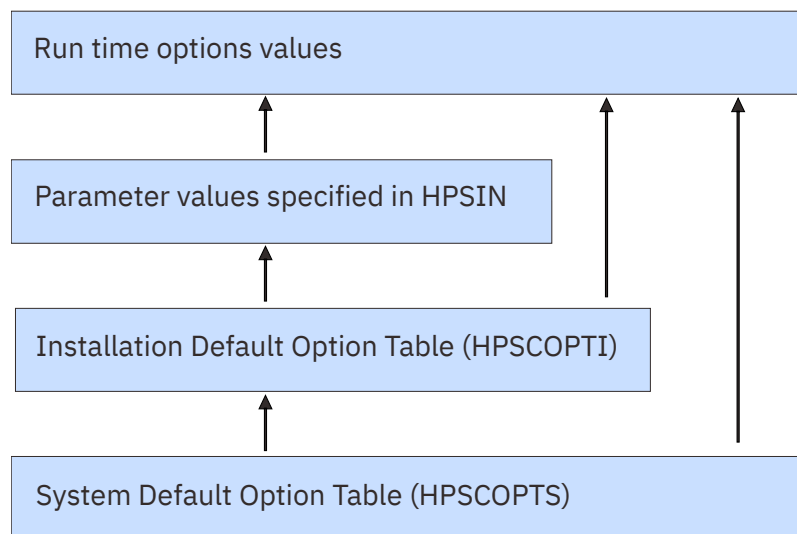

Figure 225. How runtime options are determined

PSPI

---

### Creating an Installation Default Option Table (HPSCOPTI)

You can create an Installation Default Option Table (HPSCOPTI) to change the default values of some options.

PSPI

If you link-edit HPSCOPTI to your IMS Database Reorganization Expert load module library, the default values specified in HPSCOPTI apply to all IMS Database Reorganization Expert utility jobs that use the library.

To do this, the following steps are required:

1. Copy the sample JCL stream HPSCOPTG from the sample library.  
(see “HPSCOPTG sample JCL stream” on page 618).
2. Modify the HPSCOPT macro statements in the copied JCL stream.  
(see “How to code HPSCOPT macro statements” on page 618).
3. Submit the JCL stream to assemble the HPSCOPT macro statements and link-edit the module HPSCOPTI into the IMS Database Reorganization Expert load module library or a user library.

The options that can be changed by creating an HPSCOPTI are described in “How to code HPSCOPT macro statements” on page 618.



## HPSCOPTG sample JCL stream

IMS Database Reorganization Expert provides a sample JCL stream for creating an Installation Default Option table (HPSCOPTI).



You can use the JCL stream HPSCOPTG as a sample when you create your HPSCOPTI. HPSCOPTG is provided as a member of the HPS.SHPSSAMP library. It assembles the user-specified HPSCOPT macro statements and link-edits the output of the assembly into the HPS.SHPSLMD0 load module library to build the module HPSCOPTI.



## How to code HPSCOPT macro statements

The installation default options are specified by coding a set of HPSCOPT macro statements.



These statements are assembly language macro instructions and therefore are subject to the rules contained in the *High Level Assembler Programmer's Guide*. The general syntax of the HPSCOPT macro statement is as follows:

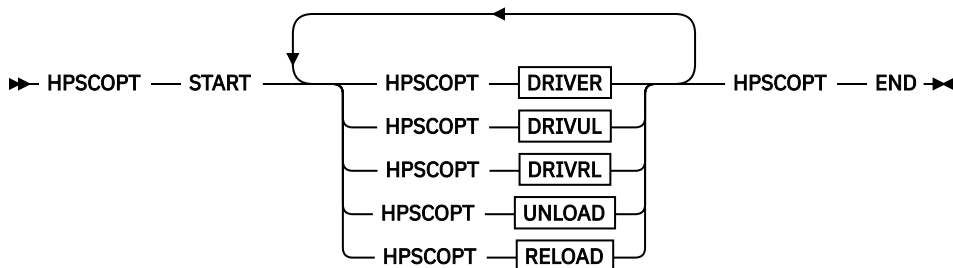

### DRIVER

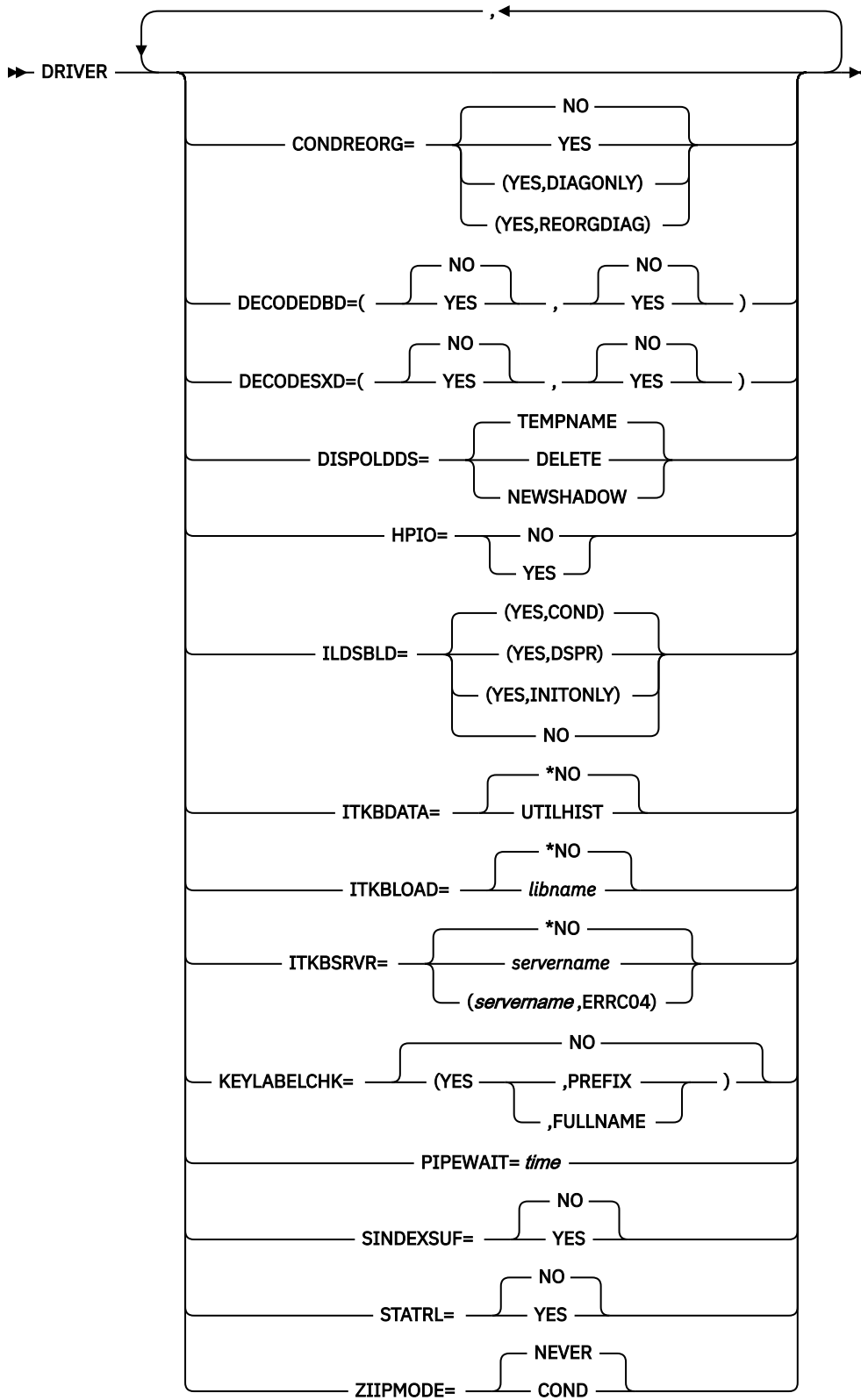

**DRIVUL**

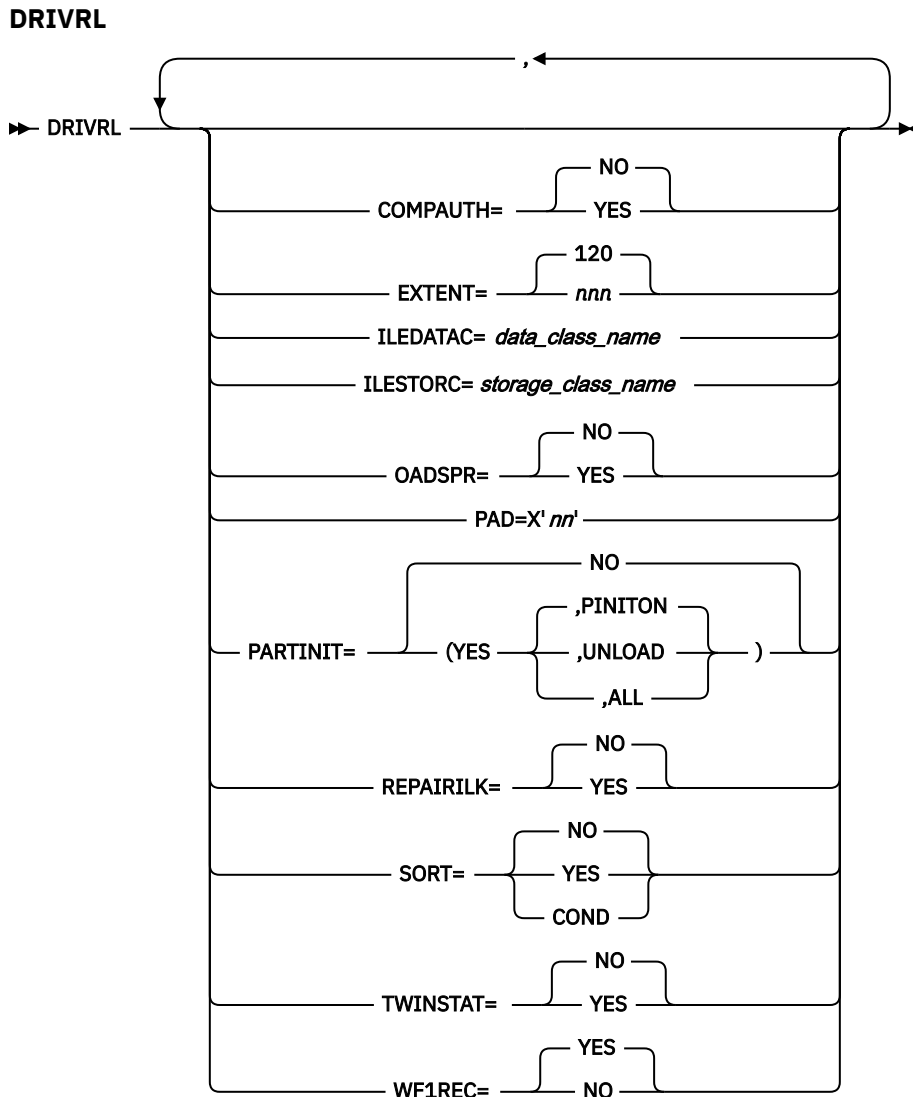
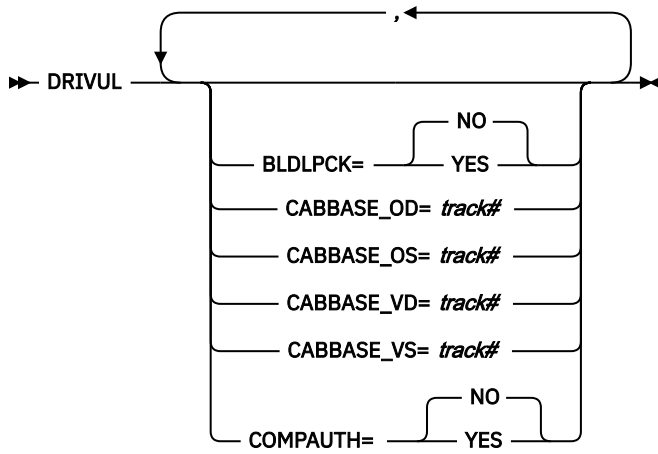

**UNLOAD**

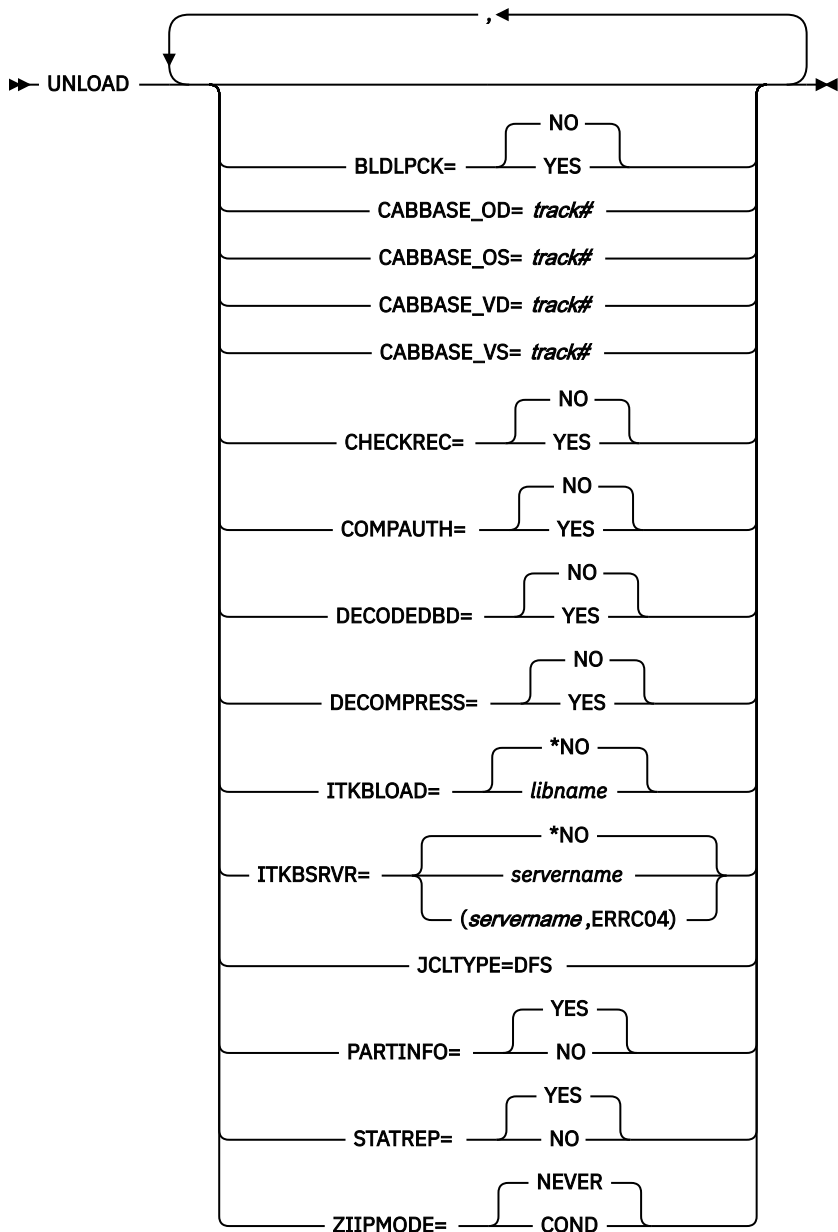

**RELOAD**

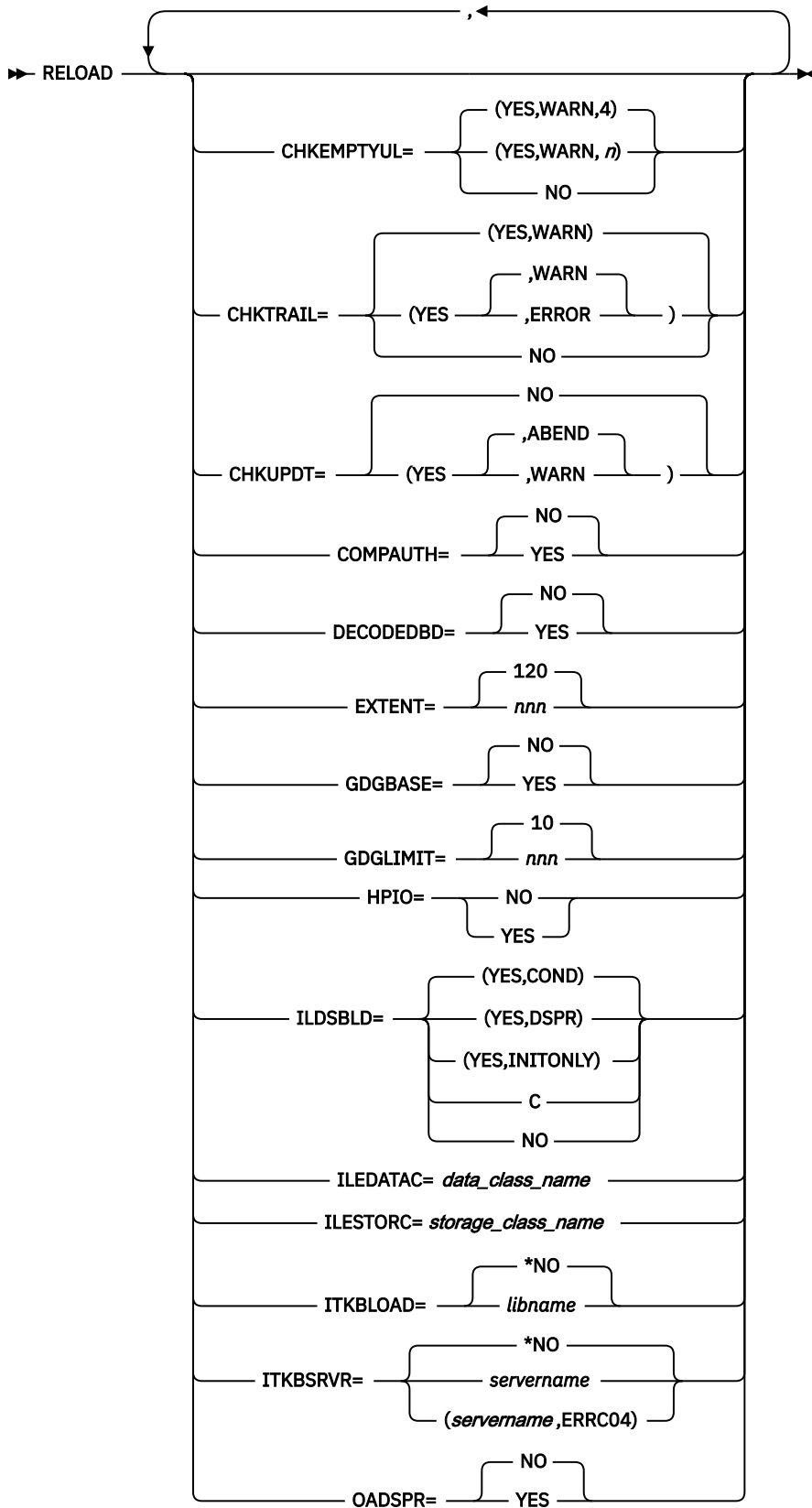

**RELOAD (continued)**

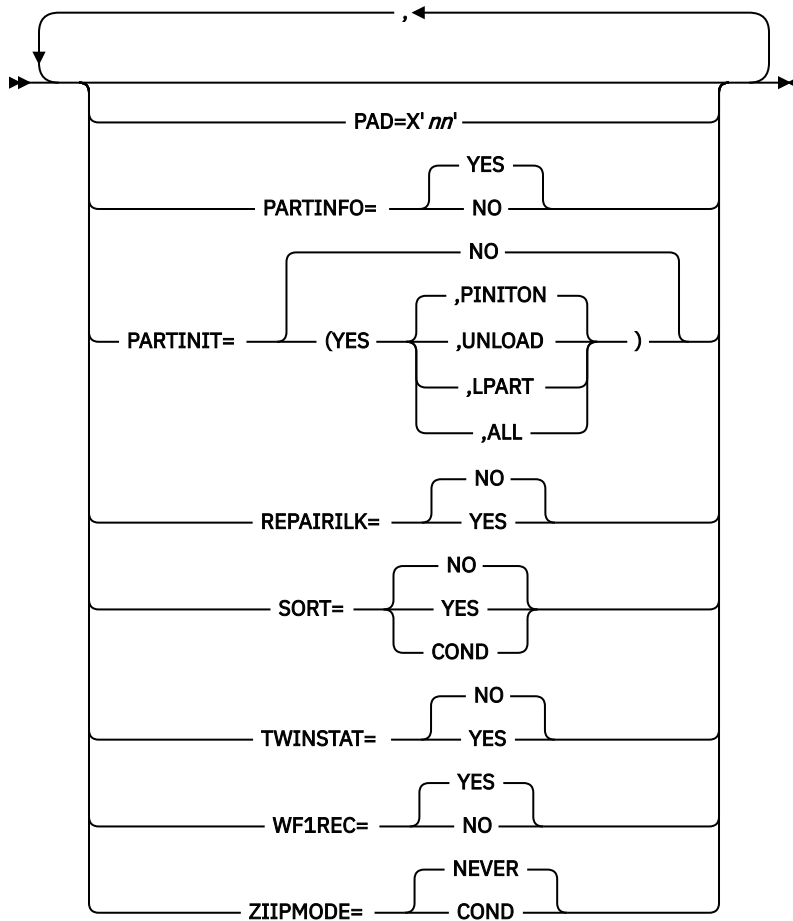

You must specify a set of HPSCOPT macro statements in the following sequence:

1. An HPSCOPT macro statement specifying START as the first positional parameter.
2. One or more HPSCOPT macro statements specifying the identifier of the utility as the first positional parameter, plus keywords and their parameters.
3. An HPSCOPT macro statement specifying END as the first positional parameter.

The identifier of each utility and the option keywords that are supported by the utility are as follows:

#### DRIVER

This parameter identifies the Smart Reorg Driver (HPSGMAIN). This parameter supports the following values:

- CONDREORG
- DECODEDBD
- DECODESXD
- DISPOLDDS
- HPIO
- ILDSBLD
- ITKBDATA
- ITKBLOAD
- ITKBSRVR
- KEYLABELCHK
- PIPEWAIT (*time* is applied to both wait states of each PIPE; the open wait state (OPEN) and the read and write wait state (RDWR).)

- SINDEXSUF
- STATRL
- ZIIPMODE

#### **DRIVUL**

This parameter identifies the Unload task under the Smart Reorg Driver. This parameter supports the following values:

- BLDLPCK
- CABBASE\_OD
- CABBASE\_OS
- CABBASE\_VD
- CABBASE\_VS
- COMPAUTH

#### **DRIVRL**

This parameter identifies the Reload task under the Smart Reorg Driver. This parameter supports the following values:

- COMPAUTH
- EXTENT
- ILEDATAC
- ILESTORC
- OADSPR
- PAD
- PARTINIT (You can specify PARTINIT only when REORGINPUT=ULDS. All options except (YES,LPART) are supported.)
- REPAIRILK
- SORT
- TWINSTAT
- WF1REC

#### **UNLOAD**

This parameter identifies the IPR Unload utility. This parameter supports the following values:

For the Unload utility:

- BLDLPCK
- CABBASE\_OD
- CABBASE\_OS
- CABBASE\_VD
- CABBASE\_VS
- CHECKREC
- COMPAUTH
- DECODEDBD
- DECOMPRESS
- ITKBLOAD
- ITKBSRVR
- JCLTYPE
- PARTINFO
- STATREP



- ZIIPMODE

For details about the JCLTYPE option, see [“Steps to run the JCL for IMS HD Reorganization Unload” on page 364](#).

For the API function:

- APISET
- PCBLIST

The Unload task under Smart Reorg uses the option table for DRIVUL, not the one for UNLOAD.

## **RELOAD**

This parameter identifies the IPR Reload utility. This parameter supports the following values:

- CHKEMPTYUL
- CHKTRAIL
- CHKUPDT
- COMPAUTH
- DECODEDBD
- EXTENT
- GDGBASE
- GDGLIMIT
- HPIO
- ILDSBLD
- ILEDATAAC
- ILESTORC
- ITKBLOAD
- ITKBSRVR
- OADSPR
- PAD
- PARTINFO
- PARTINIT
- REPAIRILK
- SORT
- TWINSTAT
- WF1REC
- ZIIPMODE

The Reload task under Smart Reorg uses the option table for DRIVRL, not the one for RELOAD.

PSPI

## **HPSCOPT macro statement examples**

---

Use the following examples to code HPSCOPT macro statements.

PSPI

## Example: Changing default values to achieve best performance (Smart Reorg, IPR Unload, IPR Reload)

Use the following HPSCOPT macro statements to improve the performance of Smart Reorg utility jobs, IPR Unload utility jobs, and IPR Reload utility jobs.

Parameters specified in this example are explained in [Chapter 44, “Performance tips and considerations,”](#) on page 609.

```
HPSCOPT START
* -----
* FOR SMART REORG UTILITY (PGM=HPSGMAIN)
* -----
HPSCOPT DRIVER, *
    HPIO=YES, *
    ILDSBLD=(YES,COND), *
    PIPEWAIT=15, *
    STATRL=NO, *
    ZIIPMODE=COND
HPSCOPT DRIVUL, *
    CABBASE_OS=8
HPSCOPT DRIVRL, *
    OADSPR=YES, *
    PARTINIT=(YES,UNLOAD), *
    SORT=COND
* -----
* FOR IPR UNLOAD UTILITY (PGM=HPSCMAIN,PARM='FUNC=UL')
* -----
HPSCOPT UNLOAD, *
    CABBASE_OS=8, *
    CHECKREC=YES, *
    DECOMPRESS=NO, *
    STATREP=NO, *
    ZIIPMODE=COND
* -----
* FOR IPR RELOAD UTILITY (PGM=HPSCMAIN,PARM='FUNC=RL')
* -----
HPSCOPT RELOAD, *
    HPIO=YES, *
    ILDSBLD=(YES,COND), *
    OADSPR=YES, *
    PARTINIT=(YES,UNLOAD), *
    SORT=COND, *
    ZIIPMODE=COND
* -----
HPSCOPT END
END
```

## Example: Changing default values of DECODEDBD and DECODESXD (Smart Reorg, IPR Unload, IPR Reload)

Use the following HPSCOPT macro statements to change all of the default values of DECODEDBD and DECODESXD options for the IPR Unload utility, the IPR Reload utility, and the Smart Reorg utility to YES.

```
HPSCOPT START
HPSCOPT UNLOAD,DECODEDBD=YES
HPSCOPT RELOAD,DECODEDBD=YES
HPSCOPT DRIVER,DECODEDBD=(YES,YES),DECODESXD=(YES,YES)
HPSCOPT END
```

## Example: Changing default values of PARTINFO (IPR Unload) and DECODEDBD (Smart Reorg)

Use the following HPSCOPT macro statements to change the default value as follows:

- Change the default value of the PARTINFO option for the IPR Unload utility to NO.
- Change the default value of the DECODEDBD option for the Smart Reorg utility to (YES,NO).

Note that this example does not change the default values for the IPR Reload utility.

```
HPSCOPT START
HPSCOPT UNLOAD, PARTINFO=NO
HPSCOPT RELOAD
HPSCOPT DRIVER, DECODEDBD=(YES, NO)
HPSCOPT END
```

### Example: Changing default values of OADSPR (Smart Reorg and IPR Reload)

Use the following HPSCOPT macro statement to change the default values as follows:

- Change the default value of the OADSPR option for the Reload task under the Smart Reorg utility to YES.
- Change the default value of the OADSPR option for the IPR Reload utility to YES.

```
HPSCOPT START
HPSCOPT DRIVRL, OADSPR=YES
HPSCOPT RELOAD, OADSPR=YES
HPSCOPT END
```

### Example: Changing default values of CONDREORG (Smart Reorg)

Use the following HPSCOPT macro statements to change the default value of the CONDREORG option to YES to run the conditional reorganization jobs by default.

```
HPSCOPT START
HPSCOPT DRIVRL, CONDREORG=YES
HPSCOPT END
```

PSPI



---

## Chapter 46. Database tuning guide

The following topics provide information for tuning your databases by using the reports of the Smart Reorg utility, IPR Unload utility, and IPR Reload utility.

The main points of database tuning are as follows:

- Reduce the number of database I/Os
- Shorten the response time of database I/O
- Improve the space usage of the database

### IMPORTANT NOTICE

The settings and target values for some key indicators that are suggested throughout this IMS Database Space Tuning Guide are based on experiments on simulated databases and applications in a controlled laboratory environment. The experiments were run in non-production, test environments.

Any suggested target values are provided as guidance for database administrators who do not have practical experience with tuning of their databases. Database performance may be affected by numerous factors, including, but not limited to, the specific applications run against the database, how the database is maintained, and factors beyond those described in this guide that may exist. After gaining experience with the tuning of the real-life databases of their installation, database administrators should review and adapt the proposed target values to their specific databases and operational environments. Therefore, the provided target values must be regarded as general rules of thumb that provide a reasonable starting point when concrete tuning experience with the real-life databases of the installation is lacking.

#### Topics:

- [“Reports for database tuning” on page 629](#)
- [“Working on exceptions in an HDAM database” on page 631](#)
- [“Working on exceptions in a HIDAM database” on page 644](#)
- [“Working on exceptions in a HISAM or SHISAM database” on page 646](#)
- [“Working on space shortage exceptions” on page 649](#)

---

## Reports for database tuning

The utilities of IMS Database Reorganization Expert generate various useful reports that assist you when tuning your IMS databases.

This topic summarizes the reports of the Smart Reorg utility, the IPR Unload utility, and the IPR Reload utility that can be used for database tuning, and how they can assist you in database tuning.

### Segment Statistics report

This report can be used to check the average length per segment, the compression ratio of variable-length segment, and the status of splits.

This report is always generated by the IPR Reload utility. The IPR Unload utility generates the report unless STARTREP=NO is specified.

### HDAM Root Addressable Area Statistics report

This report can be used for tuning randomizing processes. The report includes the key indicators for measuring quality of randomizing, the distribution of RAP chain lengths, and the distribution of root segment locations.

This report is always generated by the IPR Reload utility. The IPR Unload utility generates the report unless STARTREP=NO is specified.

### **HDAM RAP Chain I/O Summary report**

This report can be used to check the performance of the randomizer from the viewpoint of database I/O. The report also includes the packing density of root addressable area.

The Smart Reorg utility generates the report only when the database is reorganized and DBSTATS=YES is specified for the Unload task. The report is generated only for the database before reorganization. Unless STARTREP=NO is specified, the IPR Unload utility generates the report when DBSTATS=YES is specified.

### **Distribution of Database Record Sizes report**

This report can be used to check the average length of database records and the distribution of the length of database records to determine the block size or the CI size of database data sets.

This report is always generated by the IPR Reload utility. The IPR Unload utility generates the report unless STARTREP=NO is specified.

### **Largest Database Records report**

This report can be used to know the longest database records in the database.

This report is always generated by the IPR Unload utility unless STARTREP=NO is specified.

### **Data Set Statistics report**

This report can be used to check the DBD definition information and some statistics of each data set of the database. The DBD information includes the block size or CI size and the FRSPC parameter values. The statistics includes the largest and smallest segment lengths and the number blocks or CIs in the data set.

This report is always generated by the IPR Reload utility. The IPR Unload utility generates the report unless STARTREP=NO is specified.

### **HISAM Statistics report**

This report can be used to check the number of logical records in the data sets of a HISAM database and the chaining information of segments to the overflow data set.

This report is always generated by the IPR Reload utility. The IPR Unload generates the report unless STARTREP=NO is specified.

### **DB (Tuning) Statistics report**

This report provides a useful indicator for database tuning. The indicator is the average number of I/Os that are required to randomly read all database segments of one database record. By looking at this number in the report, the database administrator can quickly determine whether a database is well organized. The description of the report is found in the topic "DB Statistics report" in the *IMS High Performance Unload User's Guide*.

The Smart Reorg utility generates the report only when the CRSS determines that the database needs to be reorganized and DBSTATS=YES is specified for the Unload task. The report is generated only for the database before reorganization. Unless STARTREP=NO is specified, the IPR Unload utility generates the report when DBSTATS=YES is specified.

### **Decoded DBD report**

This report can be used to check DBD source statements.

The Smart Reorg utility, the IPR Unload utility, and the IPR Reload utility generate the report when DECODEDBD=YES is specified. To activate the DECODEDBD function, IMS Library Integrity Utilities is required.

### **Related reference**

#### IPR Unload reports

The IPR Unload utility produces the reports and statistics in the HPSOUT data set, the HPSLIST data set, and the HPSRAPC data set.

#### IPR Reload reports

The IPR Reload utility produces the reports and statistics in the HPSOUT data set and the HPSSNAP data set.

## Working on exceptions in an HDAM database

---

This guideline provides information to tune the primary data set group in HDAM databases. The information also applies to PHDAM partitions and their randomizers.

See the following topics according to the database exceptions that remained:

- EXCESSIVE\_SEGMENT\_SCATTERING  
See [“Average number of I/O operations per database record”](#) on page 631.
- EXCESSIVE\_HDAM\_ROOTS\_NOT\_HOME  
See [“Tuning a randomizer”](#) on page 632.
- EXCESSIVE\_HDAM\_ROOTS\_OVERFLOW  
See [“Tuning a randomizer”](#) on page 632.
- IMBALANCED\_RANDOMIZING  
See [“Tuning a randomizer”](#) on page 632.
- AVERAGE\_DB\_RECORD\_LENGTH  
See [“Tuning HDAM database that have long database records”](#) on page 642.
- DATA\_SET\_EXTENTS\_AVAILABILITY and GROWING\_DBDS\_WITH\_DATA\_FULL  
See [“Working on space shortage exceptions”](#) on page 649

### Average number of I/O operations per database record

HDAM randomizing is considered to be efficient if the average number of I/O operations that are required to randomly read all database segments of one database record is low. The average number of I/Os required to read at random all database segments of one database record is one of the most important indicators of the quality of the randomizing.

The average number of I/O operations is reported in the DB Tuning Statistics report. By looking at this average number, the database administrator can determine if a database is randomized efficiently without analyzing the entire report. For information about how to generate this report, see [“Reports for database tuning”](#) on page 629.

For an ideal database that consists of a single data set group, this average number is 1.0. However, in a real production database, this ideal value is typically difficult to achieve and the average number of database I/Os per database record is higher. Achieving a good randomizing value is easier when the block size, divided by average database record length, is large.

As a general guideline, a database is considered as well randomized if the average number of I/Os per database record meets the following criteria:

- Is below 1.20 for databases with an average database record length below one tenth of the block or CI size
- Is below 1.30 for databases with larger average database record lengths

Numbers above 1.20 and 1.30 might indicate that a database is poorly randomized (unless the database record length is large). In this case, the database administrator can use other numbers that are provided by the reports listed in [“Reports for database tuning”](#) on page 629 to determine the reason for the poor randomizing. See [“Tuning a randomizer”](#) on page 632 for information about how to use those numbers to tune a randomizer.

For HDAM databases with a high percentage of very long database records, achieving a low value for the average number of I/O per database record is difficult. See [“Tuning HDAM database that have long database records”](#) on page 642 for information about using reports that are produced by the IPR Unload utility to tune HDAM databases that have long records.

## Tuning a randomizer

This topic discusses how to fit as many root segments as possible in the home block when you find out that the randomizing process is not functioning well.

If, in an HDAM database, there are many root segments that do not fit in the home block (the home block is the block the root segment must be placed in, based on the randomizing routine), the randomizing parameters might not be functioning well.

Whether the randomizing process is functioning well or not can be checked by the steps in [“Example to assess the effectiveness of the randomizing module”](#) on page 632.

If there are more root segments than can be fit in the home block, check the factors discussed in the following topics:

- [“Example to assess the effectiveness of the randomizing module”](#) on page 632
- [“Is the number of RAPs appropriate?”](#) on page 634
- [“Is the size of the Root Addressable Area appropriate?”](#) on page 636
- [“Is the HDAM bytes limit appropriate for the database record lengths in this database?”](#) on page 638
- [“Is the block size or CI size appropriate for the database record lengths of this database?”](#) on page 639
- [“Is the amount of free space specified during DBDGEN equal to zero?”](#) on page 639
- [“Specifying randomizing parameters of an HDAM database”](#) on page 640

### Example to assess the effectiveness of the randomizing module

To check to which home block the root segment belong, see the HDAM Root Placement section of the HDAM Root Addressable Area Statistics report.

This section shows the distribution of the locations—the position before or after the home block—of root segments. You can also check the root segments that do not fit in the home block from NUMBER OF ROOTS NOT IN THE RANDOMIZED BLOCK in the Key Indicators for Quality of Randomizing section of the HDAM Root Addressable Area Statistics report. [Figure 226 on page 632](#) and [Figure 227 on page 633](#) show cases where problems exist.

The following figure shows that there are many root segments that do not fit in the home block; the value of NUMBER OF ROOTS NOT IN THE RANDOMIZED BLOCK is high.

```
IMS HIGH PERFORMANCE UNLOAD                                PAGE:      1
5655-E06                                                    10/05/2023 14.24.46

                "HDAM ROOT ADDRESSABLE AREA STATISTICS"

RANDOMIZER=DFSHDC40   NBR OF RAPs=2       MAX RBN=200       MAX BYTES=4,000

<<< KEY INDICATORS FOR QUALITY OF RANDOMIZING >>>

NUMBER OF ROOT SEGMENTS.....                2,200
NUMBER OF ROOT SYNONYM CHAINS.....           383
NUMBER OF ROOTS PER SYNONYM CHAIN.....         9.4
NUMBER OF ROOTS NOT ON A SYNONYM CHAIN.....  1,406
NUMBER OF ROOTS ON A SYNONYM CHAIN.....      3,606
NUMBER OF ROOTS IN LONGEST SYNONYM CHAIN.....  16
NUMBER OF ROOTS NOT IN THE RANDOMIZED BLOCK... 1,610
NUMBER OF ROOTS PER ROOT ANCHOR POINT.....    5.5
NUMBER OF ROOT ANCHOR POINTS PER ROOT.....    0.2
NUMBER OF ROOT ANCHOR POINTS USED.....        397
NUMBER OF ROOT ANCHOR POINTS NOT USED.....     3
PERCENT OF ROOT ANCHOR POINTS USED.....      99.3%
```

*Figure 226. Database tuning of the primary data set group in an HDAM database: sample 1*

The following figure shows that there are more segments that reside on blocks other than the home block than those that reside on the home block.



"HDAM ROOT ADDRESSABLE AREA STATISTICS"

<<< HDAM ROOT PLACEMENT >>>

LOCATION	PCT	QUANTITY
- ( 11-)	1.8%	40
- 10	0.1%	3
- 9	0.0%	0
- 8	0.0%	1
- 7	0.1%	2
- 6	0.0%	0
- 5	0.0%	0
- 4	0.0%	1
- 3	0.1%	2
- 2	0.1%	3
- 1	0.1%	2
HOME BLOCK	26.8%	590
+ 1	0.1%	3
+ 2	0.1%	3
+ 3	0.2%	4
+ 4	0.1%	2
+ 5	0.0%	1
+ 6	0.1%	2
+ 7	0.1%	3
+ 8	0.1%	2
+ 9	0.0%	1
+ 10	0.0%	0
+ ( 11-)	4.1%	91
OVERFLOW	65.6%	1,444

Figure 227. Database tuning of the primary data set group in an HDAM database: sample 2

Figure 228 on page 633 and Figure 229 on page 634 show cases where the problems are solved by reloading the database.

The following figure shows that the number of root segments that do not fit in the home block has decreased; the value of NUMBER OF ROOTS NOT IN THE RANDOMIZED BLOCK has decreased.

"HDAM ROOT ADDRESSABLE AREA STATISTICS"

RANDOMIZER=DFSHDC40 NBR OF RAPS=7 MAX RBN=385 MAX BYTES=1,000

<<< KEY INDICATORS FOR QUALITY OF RANDOMIZING >>>

NUMBER OF ROOT SEGMENTS.....	2,200
NUMBER OF ROOT SYNONYM CHAINS.....	526
NUMBER OF ROOTS PER SYNONYM CHAIN.....	2.3
NUMBER OF ROOTS NOT ON A SYNONYM CHAIN.....	985
NUMBER OF ROOTS ON A SYNONYM CHAIN.....	1,215
NUMBER OF ROOTS IN LONGEST SYNONYM CHAIN.....	N/A
NUMBER OF ROOTS NOT IN THE RANDOMIZED BLOCK...	51
NUMBER OF ROOTS PER ROOT ANCHOR POINT.....	1.5
NUMBER OF ROOT ANCHOR POINTS PER ROOT.....	1.2
NUMBER OF ROOT ANCHOR POINTS USED.....	1,511
NUMBER OF ROOT ANCHOR POINTS NOT USED.....	1,184
PERCENT OF ROOT ANCHOR POINTS USED.....	56.1%

Figure 228. Database tuning of the primary data set group in an HDAM database: sample 3

The following figure shows that the number of root segments in the home block has increased.

```

"HDAM ROOT ADDRESSABLE AREA STATISTICS"
<<< HDAM ROOT PLACEMENT >>>

```

LOCATION	PCT	QUANTITY
- 3	0.3%	6
- 2	0.5%	11
- 1	2.7%	59
HOME BLOCK	96.4%	2,121
+ 1	0.1%	3
+ 2	0.0%	0
+ 3	0.0%	0
OVERFLOW	0.0%	0

Figure 229. Database tuning of the primary data set group in an HDAM database: sample 4

“Tuning a randomizer” on page 632 describes the details on how to tune a database.

## Is the number of RAPs appropriate?

Use the values in the following reports to determine whether the number of RAPs is appropriate.

### • HDAM Root Addressable Area Statistics report

- NUMBER OF ROOTS PER ROOT ANCHOR POINT in the Key Indicators for Quality of Randomizing section

This value is obtained by dividing the number of root segments (NUMBER OF ROOT SEGMENTS) by the number of RAPs that have at least one root segment assigned (NUMBER OF ROOT ANCHOR POINTS USED). When there are many synonyms, this value is large.

- NUMBER OF ROOT ANCHOR POINTS PER ROOT in the Key Indicators for Quality of Randomizing section

This value is obtained by dividing the number of total RAPs by the number of root segments (NUMBER OF ROOT SEGMENTS). You can check the ratio of the number of RAPs specified to the root segments. A recommended value for this field is 1.2.

Generally, the number of RAPs must be approximately 1.2 times the number of database records. When in doubt, it is better to specify too many rather than too few RAPs (because a RAP is only 4 bytes and hence inexpensive in terms of DASD space)<sup>Note</sup>. For details, see *IMS Database Administration* for the version of IMS you are using.

**Note:** An exception to this recommendation is an Intersystem block-level sharing environment with sequential database processing. In such an environment, the number of RAPs must not be too large because access to each RAP might create intersystem block-level sharing delays.

### Discussion of the example

In Figure 226 on page 632, the value of NUMBER OF ROOT ANCHOR POINTS PER ROOT is small, which can mean that the number of RAPs is not enough. This might be the cause of the value NUMBER OF ROOTS PER ROOT ANCHOR POINT being so large.

The following figure shows a case where the database was reloaded after increasing the value of MAX RBN (the maximum RBN value, one of the randomizing parameters).

"HDAM ROOT ADDRESSABLE AREA STATISTICS"

RANDOMIZER=DFSHDC40 NBR OF RAPS=2 MAX RBN=1,320 MAX BYTES=4,000

<<< KEY INDICATORS FOR QUALITY OF RANDOMIZING >>>

NUMBER OF ROOT SEGMENTS.....	2,200
NUMBER OF ROOT SYNONYM CHAINS.....	531
NUMBER OF ROOTS PER SYNONYM CHAIN.....	2.3
NUMBER OF ROOTS NOT ON A SYNONYM CHAIN.....	961
NUMBER OF ROOTS ON A SYNONYM CHAIN.....	1,239
NUMBER OF ROOTS IN LONGEST SYNONYM CHAIN.....	N/A
NUMBER OF ROOTS NOT IN THE RANDOMIZED BLOCK...	79
NUMBER OF ROOTS PER ROOT ANCHOR POINT.....	1.5
NUMBER OF ROOT ANCHOR POINTS PER ROOT.....	1.2
NUMBER OF ROOT ANCHOR POINTS USED.....	1,492
NUMBER OF ROOT ANCHOR POINTS NOT USED.....	1,148
PERCENT OF ROOT ANCHOR POINTS USED.....	56.5%

Figure 230. Database tuning of the primary data set group in an HDAM database: sample 5

Because MAX RBN has increased, NUMBER OF ROOT ANCHOR POINTS PER ROOT has also increased. This means that the problem of insufficient number of RAPs has been solved. Also, NUMBER OF ROOTS PER ROOT ANCHOR POINT has decreased, which means the number of synonyms has also decreased.

Use the values in the following reports to determine the appropriate number of RAPs assigned for a block or a CI.

• **Data Set Statistics report**

- You can check the block size or the CI size and the number of blocks or the number of CIs that specify about the data set.

• **Distribution of Database Record Sizes report**

- CUM PCT

You can check what percent of the database records can fit on the length that you want to specify. You can use the value to determine the appropriate number of RAPs for that block. For multiple data set groups, however, you cannot use the value as it is.

**Discussion of the example**

The following description is true only when there is only one data set group and when the bytes limit—the maximum number of bytes of a database record that can be inserted into this database's root segment addressable area; one of the randomizing parameters—is not specified.

The following figure shows that the block size or the CI size is 8192 bytes. Figure 232 on page 636 shows that the size of 18.0% of database records are 2000 bytes or less, and 92.7% are 4000 bytes or less.

"DATA SET STATISTICS"

DSG	DDNAME	BLOCK SIZE	RECORD SIZE	DATA SET NAME
1	DDHDV10	8,192	8,185	TESTDS.NTFC5201.DBHDV10.DDHDV10

DSG	DDNAME	FBBF	FSPF	FSPF BYTES	SMALL SEGSZE	LARGE SEGSZE	TOTAL BLOCKS
1	DDHDV10	0	0	0	86	1,006	629

NUMBER OF BLOCKS IN OVERFLOW = 429

Figure 231. Database tuning of the primary data set group in an HDAM database: sample 6

"DISTRIBUTION OF DATABASE RECORD SIZES"

RANGE	QUANTITY	PCT	CUM PCT
- 100	0	0.0%	0.0%
101 - 200	0	0.0%	0.0%
201 - 300	0	0.0%	0.0%
301 - 400	20	0.9%	0.9%
401 - 500	0	0.0%	0.9%
501 - 600	0	0.0%	0.9%
601 - 700	0	0.0%	0.9%
701 - 800	0	0.0%	0.9%
801 - 900	0	0.0%	0.9%
901 - 1000	0	0.0%	0.9%
1001 - 2000	375	17.0%	18.0%
2001 - 3000	1,549	70.4%	88.4%
3001 - 4000	95	4.3%	92.7%
4001 - 5000	154	7.0%	99.7%
5001 - 6000	7	0.3%	100.0%
6001 - 7000	0	0.0%	100.0%
7001 - 8000	0	0.0%	100.0%
8001 - 9000	0	0.0%	100.0%
9001 - 10000	0	0.0%	100.0%
10001 -	0	0.0%	100.0%
AVERAGE DATABASE RECORD SIZE =		2,317	
SHORTEST DATABASE RECORD SIZE =		318	
LONGEST DATABASE RECORD SIZE =		5,808	

Figure 232. Database tuning of the primary data set group in an HDAM database: sample 7

If, for instance, the number of RAPs per block or CI is 4, 18.0% of database records fit both the root and the dependent segments on one block or on one CI. If, for instance, the number of RAPs per a block or a CI is 2, 92.7% of database records fit both the root and the dependent segments on one block or on one CI.

When the dependent segments reside on the same block or CI as the root segment, the access time is shorter (than when the segments reside on different blocks or CIs). However, if the frequency of access to the dependent segments is low, where these two types of segments reside is not a significant factor for performance. Therefore, trade-off between the access speed and the size of the database data set must be considered according to the operation.

### Is the size of the Root Addressable Area appropriate?

This topic discusses whether the size of the Root Addressable Area is appropriate.

As a reasonable rule of thumb, if you are using a standard DFSHDC40 randomizer or the Sequential Subset Randomizer, the percentage of space used for segments in an RAA (shown as OTHER KEY INDICATORS in the HDAM RAP Chain I/O Summary report of the IPR Unload utility, and referred to as *Packing Density*) must be as follows:

- 75% (for databases with an average database record length smaller than one tenth of the CI/block size)
- 70% (for databases with a larger average database record length)

#### Notes:

1. Aiming for higher packing densities saves DASD space, but often decreases the performance of HDAM database accesses. Each installation will have probably its own idea of what is the ideal trade-off between DASD space and performance and regarding the ideal packing density. For example, some installations might want packing densities of 75% and 80% (instead of the target values of 70% and 75%).
2. For small or medium-sized HDAM databases (when saving DASD space is not important), it is often reasonable to aim for a packing density below 70%.

3. If the total size of all database records will eventually grow, it is then reasonable to oversize the root addressable area at database reload time, in order to provide enough space for the future data growth.

You can change the packing density of the root addressable area by varying the number of blocks or CIs in the root addressable area and by varying the size of a block or CI. Increasing the number of blocks or CIs or increasing the block or CI size increases the size of the root addressable area and lower its packing density; this typically increases the performance of random accesses to the database.

Varying the bytes limit might also change the packing density of the root addressable area (reducing the bytes limit will tend to store more information in the overflow area and less information in the root addressable area; this will hence tend to reduce the packing density in the root addressable area).

**Discussion of the example**

Packing Density is printed under OTHER KEY INDICATORS in the HDAM RAP Chain I/O Summary report of the IPR Unload utility.

In the following figure, the value of PACKING DENSITY OF ROOT ADDRESSABLE AREA is too high. To lower the value of packing density, you can increase the number of blocks or the number of CIs in the RAA, or you can decrease the total bytes of the segments in the RAA, and so on. Make appropriate specifications, taking into account the pros and cons previously discussed.

```

IMS HIGH PERFORMANCE UNLOAD                                PAGE: 1
5655-E06                                                    10/05/2023 13.10.59

                "HDAM RAP CHAIN I/O SUMMARY"

KEY INDICATORS FOR QUALITY OF RANDOMIZING FROM A VIEWPOINT OF DATABASE I/O

AVG NBR OF I/O PER DB RECORD.....                2.91
AVG NBR OF I/O ON RAP CHAIN PER ROOT.....         1.66
AVG NBR OF I/O ON RAP CHAIN PER RAP CHAIN.....    2.00
AVG NBR OF I/O IN ROOT ADDRESSABLE AREA PER DB RECORD... 1.50
AVG NBR OF I/O IN OVERFLOW AREA PER DB RECORD..... 1.41
AVG POSITION OF ROOT SEGMENTS ON RAP CHAINS.....   1.33

OTHER KEY INDICATORS

PACKING DENSITY OF ROOT ADDRESSABLE AREA.....     46.09

NBR OF I/O'S REQUIRED TO READ A ROOT SEGMENT RANDOMLY
(SIMULATED WITH 4 PCB-BUFFERS)

  NBR I/O    NBR ROOTS    PCT    CUM PCT
  -----    -----    ----    -----
    1             4    33.33%   33.33%
    2             8    66.66%  100.00%

POSITION OF ROOT SEGMENTS ON RAP CHAINS

  POSITION    NBR ROOTS    PCT    CUM PCT
  -----    -----    ----    -----
    1             8    66.66%   66.66%
    2             4    33.33%  100.00%

```

Figure 233. Database tuning of the primary data set group in an HDAM database: sample 8

You can check the block size or the CI size and the number of blocks or the number of CIs of the current database data sets in the Data Set Statistics report. You can check the average size of database records in AVERAGE DATABASE RECORD SIZE of the Distribution of Database Record Sizes report.

The value of the bytes limit (MAX BYTES) that is specified is printed in the top part of the HDAM Root Addressable Area Statistics report (and also in the DBD Summary report for a non-HALDB).

Figure 226 on page 632 shows that MAX BYTES= is blank, which means the bytes limit is not specified. For details, see [“Is the HDAM bytes limit appropriate for the database record lengths in this database?”](#) on page 638.

## Is the HDAM bytes limit appropriate for the database record lengths in this database?

The bytes limit is the maximum number of bytes of a database record that can be stored into the root addressable area in a series of insert calls unbroken by a call to another database record.

The bytes limit is shown in the top part of the HDAM Root Addressable Area Statistics report.

The database administrator needs to perform a trade-off when specifying a bytes limit. Specifying a bytes limit that is too small results in the storing of too many database segments into the overflow area. Access to these many database segments in the overflow area typically triggers additional I/Os (since these database segments are not stored in the same block or CI as the root segment in the root addressable area); these additional I/Os adversely affect the performance of access to the HDAM database.

Specifying a bytes limit that is too high (for example, 10 times the average database record length) might create a situation where one individual database record occupies too much space in the root addressable area. Other database records of the same block or CI or of neighboring blocks or CIs will then have an insufficient amount of DASD space available for the storing of their own database segments in the same block or CI as the RAP. Access to the database segments of these other database records requires additional I/Os. This adversely affects the performance of access to the HDAM database.

**Note:** Specification of a bytes limit that is too high often creates a *cascade* effect. If, for example, one database record randomizing to block n is allowed to store as many as five block sizes worth of data in the root addressable area, then the database records that are randomized to neighboring blocks (for example, block n, n+1, n+2, n+3, and n+4) cannot be stored in the same block as their RAPs. The segments of these database records will spill into blocks n+5, n+6, and so on, and will create problems for the database records that are randomized in block n+5, n+6, and so on. Note that the PSSR utility of IMS HP Load assists in preventing such cascading effects.

### Discussion of the example

See AVG SEGM LENGTH and AVG OCCURRENCES PER RECORD in the Segment Statistics report. The sum of the products of AVG SEGM LENGTH and AVG OCCURRENCES PER RECORD of the segments that are used frequently is compared with the specified bytes limit. You can check whether the bytes limit is appropriate.

In [Figure 234](#) on [page 638](#), the bytes limit is specified as 1000. [Figure 235](#) on [page 639](#) shows that you can put segments from ROOTLEV1 to DEP2LEVE2 in RAA with no problem, but if you want to put all segments in RAA, you might have to specify a value larger than 1000 for the bytes limit.

```
IMS HIGH PERFORMANCE LOAD                                PAGE: 1
5655-M26                                                10/05/2023 13.10.14

"HDAM ROOT ADDRESSABLE AREA STATISTICS"

RANDOMIZER=DFSHDC40   NBR OF RAPS=7       MAX RBN=385       MAX BYTES=1,000

<<< KEY INDICATORS FOR QUALITY OF RANDOMIZING >>>

NUMBER OF ROOT SEGMENTS.....                2,200
NUMBER OF ROOT SYNONYM CHAINS.....            526
NUMBER OF ROOTS PER SYNONYM CHAIN.....        2.3
NUMBER OF ROOTS NOT ON A SYNONYM CHAIN.....   985
NUMBER OF ROOTS ON A SYNONYM CHAIN.....       1,215
NUMBER OF ROOTS IN LONGEST SYNONYM CHAIN..... N/A
NUMBER OF ROOTS NOT IN THE RANDOMIZED BLOCK... 51
NUMBER OF ROOTS PER ROOT ANCHOR POINT.....    1.5
NUMBER OF ROOT ANCHOR POINTS PER ROOT.....    1.2
NUMBER OF ROOT ANCHOR POINTS USED.....        1,511
NUMBER OF ROOT ANCHOR POINTS NOT USED.....    1,184
PERCENT OF ROOT ANCHOR POINTS USED.....       56.1%
```

Figure 234. Database tuning of the primary data set group in an HDAM database: sample 9

"SEGMENT STATISTICS"

SEGMENT STATISTICS

SEGMENT	TOTAL NBR OF OCCURRENCES	<-----AVG OCCURRENCES-----> PER PARENT	PER RECORD	AVG SEGM LENGTH	<--CONTRIBUTION TO DB RECORD SIZE--> PCT	CUM SIZE
ROOTLEV1	2,200	1.0	1.0	318	20.0%	318
DEP1LEV2	314	0.1	0.1	786	7.1%	430
DEP2LEV2	14,217	6.5	6.5	50	20.3%	753
DEP3LEV3	8,547	0.6	3.9	46	11.3%	932
DEP4LEV2	28,290	12.9	12.9	51	41.3%	1,588

SEGMENT IN OVERFLOW STATISTICS

SEGMENT	<-----OVERFLOW-----> NUMBER	PCT
ROOTLEV1	0	0.0%
DEP1LEV2	298	94.9%
DEP2LEV2	3,001	21.1%
DEP3LEV3	5,019	58.7%
DEP4LEV2	17,849	63.1%
TOTAL SEGMENTS =	53,568	

Figure 235. Database tuning of the primary data set group in an HDAM database: sample 10

## Is the block size or CI size appropriate for the database record lengths of this database?

This topic discusses the block size or CI size for the database record lengths.

A general rule of thumb is a 4 KB CI/block size for HDAM. However, if the average database record length is higher than 800 bytes (that is, larger than 1/5th of the block or CI size), then an increase of the block or CI size from 4 KB to 8 KB might improve the performance of HDAM database accesses (especially if the database administrator wants a high packing density (more than 70%) of the root addressable area). In this case, an increase of the CI size/block size from 4 KB to 8 KB can often reduce the number of I/O operations (but will increase slightly the time of an I/O operation). CI/block sizes larger than 8 KB should be an exception (for example, for very large average database record sizes).

### Discussion of the example

You can check the current block size or the CI size, and the number of blocks and the number of CIs in the Data Set Statistics report. You can also check the average length of database records in AVERAGE DATABASE RECORD SIZE of the Distribution of Database Record Sizes report. You need to make specifications correctly, taking into account the pros and cons discussed.

## Is the amount of free space specified during DBDGEN equal to zero?

This topic discusses whether the amount of free space that is specified during DBDGEN is equal to zero or not.

### Free space within each block/CI

Specification on the DATASET macro of DBDGEN of free space within each block or CI has both advantages and disadvantages.

Free space within each block or CI is often advantageous, if the database will have many insert activities after database load/reload in the overflow area. In this case, free space specifications often reduce the scattering of database segments of the same database record into a large number of different blocks or CIs during subsequent insert activities.

The percentage of specified free space must be taken into account when determining the size of the RAA. For example, when specifying 10% of free space, some database administrators increase the

size of the root addressable area by 10%, since the free space is not available at database load time or database reload time.

Free space within each block or CI is disadvantageous if few database segments are inserted after database load/reload or if nearly all database segments can be stored in the root addressable area.

### **Free block frequency factor**

As explained in *IMS Database Administration*, specifying a free block frequency factor on the DATASET macro of DBDGEN for the first data set group of HDAM is self-defeating. For data set groups other than the first HDAM data set group, a free block frequency specification is often useful.

### **Discussion of the example**

You can check the definition information of free space in the Dataset Statistics report. You need to specify appropriate values taking into considerations the pros and cons discussed.

## **Specifying randomizing parameters of an HDAM database**

This topic is provided to assist database administrators who do not have experience with the specifications of efficient HDAM randomizing parameters.

This topic contains general rules of thumb for using a "first guess" method to determine the values of the following parameters, which have an impact on the randomizing performance of an HDAM database:

- The block or CI size
- The bytes limit
- The number of blocks or CIs in the root addressable area
- The number of RAPs per block or CI

The following discussion assumes that the values of these parameters are determined in the sequence listed here. After loading or reloading the database with the randomizing parameters determined by the first-guess method, the database administrator can obtain the HDAM Root Addressable Area Statistics report and the Distribution of Database Record Sizes report in order to verify the efficiency of the first-guess randomizing parameters. Then, if necessary, the randomizing parameters could be adjusted with an iterative, experimental "try and see" process (that is, change the value of a randomizing parameter, reload the database, and observe the effect of the changed parameter in the HDAM Root Addressable Area Statistics report and the Distribution of Database Record Sizes report).

### ***Determining the block or CI size***

There are several factors for determining the block size or the CI size.

- A recommended general rule of thumb is a 4 KB block or CI size. However, if the average database record length reported in the Distribution of Database Record Sizes report is larger than 800 bytes, then a larger block or CI size could be tried.
- If the average database record length is in the range of 800-1600 bytes, an 8 KB block or CI size is often a better bet.
- If the average database record length is in the range of 1600-2400 bytes, a 12 KB block or CI size should be investigated.
- For average database record lengths substantially longer than 2400 bytes, the first-guess method described in this topic often does not apply.

Block or CI sizes larger than 12 KB should be an exception.

Block or CI sizes smaller than 4 KB are seldom reasonable.

### ***Determining the bytes limit***

To determine the bytes limit, you must check the distribution of the database length records in the Distribution of Database Record Sizes report.

As explained in [“Is the HDAM bytes limit appropriate for the database record lengths in this database?”](#) on page 638, the database administrator needs to perform trade-offs when specifying a bytes limit.



To define a reasonable bytes limit, the database administrator should check the Distribution of Database Record Sizes report. The table with the distribution of the database length records should be used in order to determine the bytes limit in accordance with the following rules of thumb:

- The bytes limit is large enough to allow for a high percentage of database records to have all their database segments stored in the root addressable area.
- The bytes limit is small enough to prevent the cascading effect described in [“Is the HDAM bytes limit appropriate for the database record lengths in this database?”](#) on page 638. If the average database record length is around 1/5th of the block or CI size, then (as a first guess, which could be revised by experiments by the database administrator) the bytes limit should not be larger than twice the database record length. For smaller average database record lengths, the ratio between bytes limit and average database record length can be larger than 2. For larger average database record lengths, the ratio between bytes limit and average database record length should be smaller than 2.
- The bytes limit should not be larger than the block or CI size.

### ***Determining the number of blocks or CIs in the root addressable area***

In order to determine the number of blocks or CIs in the root addressable area, the database administrator must have previously determined the block or CI size and the bytes limit.

These tasks are described in [“Determining the block or CI size”](#) on page 640 and [“Determining the bytes limit”](#) on page 640).

Then the database administrator should:

1. Select a target packing density for the root addressable area. Is the size of the root addressable area appropriate as described in [“Is the size of the Root Addressable Area appropriate?”](#) on page 636. A good bet would be a packing density of 75 for databases with an average database record length smaller than one tenth of the block or the CI size—or 70 for databases with a larger average database record length.
2. Estimate the total length (expressed in bytes) of all database segments that should be stored in the root addressable area. You can estimate the length by using:
  - a. The selected bytes limit
  - b. The distribution of the database record lengths reported by the Distribution of Database Record Sizes report

Example:

**a.**

The HDAM Root Addressable Area Statistics report shows the bytes limit specified in the randomizing parameters. Use the Distribution of Database Record Sizes report to see how much (in percentage) database records can fit on the specified bytes limit.

3. If you want to include all segments in the RAA, you can obtain the size of the RAA (in bytes) from the following formula:

$$\text{RAA size (in bytes)} = \frac{\text{AVERAGE DATABASE RECORD SIZE} \times \text{NUMBER OF ROOT SEGMENTS}}{\text{target packing density}}$$

(total length of database segments in the root addressable area)

Where:

AVERAGE DATABASE RECORD SIZE is a field in the Distribution of Database Record Sizes report and NUMBER OF ROOT SEGMENTS is a field in the HDAM Root Addressable Area Statistics report.

If you do not want to include all segments in the RAA, you can obtain the size of the RAA (in bytes) from the following formula:

$$\text{RAA size (in bytes)} = \frac{\text{Sum of ASLEN} \times \text{NUMBER OF ROOT SEGMENTS}}{\text{target packing density}}$$

(total length of database segments in the root addressable area)

Where:

Sum of ASLEN is the sum of the products of AVG SEGM LENGTH and AVG OCCURRENCES PER RECORD of the segments in the Segment Statistics report, of the segments that you want to include in the RAA and NUMBER OF ROOT SEGMENTS is a field in the HDAM Root Addressable Area Statistics report.

4. To obtain the number of blocks or CIs in the root addressable area, divide the size (in bytes) of the root addressable area by the block or CI size.

### ***Determining the number of RAPs per block or CI***

This topic discusses the factors to determine the number of RAPs per block or CI.

As a rule of thumb, the total number of RAPs should be around 1.2 times the number of database records. When in doubt, it is better to specify too many rather than too few RAPs. For details, read *IMS Database Administration* for the version of IMS that you are using. Because the number of database records is printed in NUMBER OF ROOT SEGMENTS in the HDAM Root Addressable Area Statistics report, the database administrator can multiply this number by 1.2 in order to obtain the desired total number of RAPs. Then, in order to obtain the number of RAPs per block or CI, the total number of RAPs must be divided by the number of blocks or CIs in the root addressable area (and rounded up to the next integer).

## **Tuning HDAM database that have long database records**

For HDAM databases with a high percentage of very long database records (for example, 8 KB or more), it is difficult to achieve a low value for the average number of I/O per database record.

Whether the database record length is high can be determined by looking at the Distribution of Database Record Sizes report; this provides the average database record length and a table with the distribution of the database record length. Also, you can see which database records are long by looking at the Longest Database Records report. Some of the actions that can be taken, in order to limit the performance problems of long database records, are:

- Define the bytes limit in such a way that:
  - The root segment and a reasonable amount of dependent segments can be stored in the same block of the root addressable area as the root segment.
  - The remaining dependent segments are stored in the overflow area.

A practice sometimes used is to load the most often referred-to database segments in the root addressable area at database initial load or reload time; the less frequently referred-to database segments are then inserted after the initial load/reload. Sometimes less frequently accessed segment types can be stored in a separate data set group.

Bytes limits larger than the block or CI size should not be used if the database administrator intends to store database ROOTS in most of the blocks or CIs of the root addressable area. The bytes limit of the current database is shown in the top part of the HDAM Root Addressable Area Statistics report, and for an HDAM database, also in the DBD SUMMARY report.

- Use a large block or CI size (for example, 12 KB).
- Evaluate usage of database segment compression in order to reduce the average size of database records.

The following discusses the points to be careful of when using compressed segments:

Using a compression exit routine in order to store the segments on DASD in a compressed format can be useful, especially if the compression can significantly reduce the average database record size in such a way that the average number of database I/Os required to read at random all database segments of a database record can be lowered. When using compression routines, beware of segment splits created by replace calls that extend the compressed size of a database segment. Some protection against such replace calls can be achieved by avoiding high packing densities in the root addressable area and by defining enough free space for non-primary data set groups.

- Evaluate changes to the database design in order to reduce the average size of database records.
- Evaluate usage of multiple data set groups.

## Discussion of the example

You can check the average database record size in AVERAGE DATABASE RECORD SIZE in the Distribution of Database Record Sizes report. In the following figure, AVERAGE DATABASE RECORD SIZE shows 27,999 bytes. Because this is long, the method previously described might be effective to improve performance.

```

IMS HIGH PERFORMANCE UNLOAD                                PAGE: 1
5655-E06                                                    10/05/2023 10.29.02

"DISTRIBUTION OF DATABASE RECORD SIZES"

      RANGE              QUANTITY      PCT      CUM PCT
-----
      -      1000              4      0.2%      0.2%
    1001 -      2000              0      0.0%      0.2%
    2001 -      3000             19      1.0%      1.2%
    3001 -      4000              0      0.0%      1.2%
    4001 -      5000              0      0.0%      1.2%
    5001 -      6000              0      0.0%      1.2%
    6001 -      7000              0      0.0%      1.2%
    7001 -      8000              0      0.0%      1.2%
    8001 -      9000              0      0.0%      1.2%
    9001 -     10000              0      0.0%      1.2%
   10001 -     20000             405     20.3%     21.4%
   20001 -     30000              0      0.0%     21.4%
   30001 -     40000           1,572     78.6%    100.0%
   40001 -              0      0.0%    100.0%

AVERAGE DATABASE RECORD SIZE =          27,999
SHORTEST DATABASE RECORD SIZE =           678
LONGEST DATABASE RECORD SIZE  =          31,498

```

Figure 236. Database tuning of the primary data set group in an HDAM database: sample 11

You can check the value of the bytes limit (MAX BYTES) that is specified in the top part of the HDAM Root Addressable Area Statistics report, and for an HDAM, in the DBD Summary report.

In [Figure 226 on page 632](#), the bytes limit is not specified. If there are dependent segments that are referenced at low frequency, specifying the bytes limit is effective for reducing the I/O response time of the database. You should, however, make appropriate specifications considering factors such as the use of the database and the system environment.

In [Figure 231 on page 635](#), you can check the block size or the CI size, and the number of blocks and the number of CIs of the current database in the Data Set Statistics report. In [Figure 231 on page 635](#), BLOCK SIZE shows 8,192 bytes. This is too short for AVERAGE DATABASE RECORD SIZE 27,999 bytes in [Figure 236 on page 643](#). Determine which is better: to decrease the size of the database records that fit in the block or the CI—that is, to compress or to group them into multiple data set groups, and so on—or to increase the size of the block or the CI size.

In [Figure 235 on page 639](#), if you are to use multiple data set groups, you can calculate the average record length of the database records from the root segment to the segment type that you want to include in the primary data set by using the products of AVG SEGM LENGTH and AVG OCCURRENCES PER RECORD of the Segment Statistics report.

You can check the status of segment compression in the Variable Length Segment Statistics section of the Segment Statistics report. The following figure shows that COMPRESSION FACTOR is -8.3%, which means the segment has become longer after the compression.

```

<<< VARIABLE LENGTH SEGMENT STATISTICS >>>

SEGMENT      <-----LENGTHS-----> <-----SEGMENT COUNT-----> <-COMPRESSION-->
              MIN    MAX PFX  DATA      <MIN      =>MIN      FACTOR NAME
-----
DEP1LEV2     20   120   6    96          0      24,010
DEP2LEV2     50   200  10   139          0       6,000
DEP3LEV3      4    40   6    33          0     15,747 - 8.3% DFSCMPX0

```

Figure 237. Database tuning of the primary data set group in an HDAM database: sample 12

## Working on exceptions in a HIDAM database

---

This guideline provides information to tune HIDAM databases. The information also applies to PHIDAM partitions.

See the following topics according to the database exceptions that remained:

- EXCESSIVE\_SEGMENT\_SCATTERING  
See [“Average number of I/O operations per database record”](#) on page 644.
- AVERAGE\_DB\_RECORD\_LENGTH  
See the following topics:
  - [“Is the block size or CI size appropriate?”](#) on page 645
  - [“Is the problem with long database records solved appropriately?”](#) on page 645
- DATA\_SET\_EXTENTS\_AVAILABILITY or GROWING\_DBDS\_WITH\_DATA\_FULL  
See [“Working on space shortage exceptions”](#) on page 649.

### Average number of I/O operations per database record

A database is considered to be efficiently organized if the average number of I/O operations that are required to randomly read all database segments of one database record is low. The average number of I/Os required to read at random all database segments of one database record is one of the most important indicators of the quality of the physical organization of the HIDAM database.

The average number of I/O operations is reported in the DB Tuning Statistics report. For information about generating this report, see [“Reports for database tuning”](#) on page 629. Note that the HSSR Engine ignores I/Os that are required to access the index of the HIDAM database record. By looking at this average number, the database administrator can determine if the database records and their segment occurrences are stored efficiently without analyzing the entire report.

For an ideal database that consists of a single data set group, this average number is 1.0. However, in a real production database, this ideal value is typically difficult to achieve and the average number of database I/Os per database record is higher.

As a general guideline, the database is considered to be fairly well organized if the average number of I/Os per database record meets the following criteria:

- Is below 1.10 for databases with an average database record length below one tenth of the block or CI size
- Is below 1.20 for databases with larger database record lengths

Numbers above 1.10 or 1.20 might indicate that a database is poorly organized. In this case, the database administrator should ask the following questions to determine the reason for a poor organization:

1. Is the amount of free space that was specified during DBDGEN sufficient? See [“Is there enough free space defined in DBDGEN?”](#) on page 644.
2. Is the block size or CI size appropriate for the database record lengths of this database? See [“Is the block size or CI size appropriate?”](#) on page 645.
3. Is the database record length excessive? See [“Is the problem with long database records solved appropriately?”](#) on page 645.

### Is there enough free space defined in DBDGEN?

Based on an algorithm of IMS, you need to define free space according to the database uses.

To check the current free space when defining free space, see the Dataset Statistics report. For the detail of the algorithm of IMS, see *IMS Database Administration*.

#### Discussion of the example

You can check the information about the definition of free space in the Dataset Statistics report of the IPR Unload utility and the IPR Reload utility. [Figure 231 on page 635](#) shows that the value of FSPF is 0, which

means that no free space is defined. You need to specify necessary free space taking into account the database uses based on the IMS algorithm.

The following figure is an example of the Distribution of Free Space section of the Dataset Statistics report produced by the IPR Reload utility. AVG SIZE OF FREE SPACE in the Distribution of Free Space section is printed only in the IPR Reload utility, and it shows the average free space of each data set group. This value can be used to check whether there is sufficient free space in the database after the database is reloaded.

```
<<< DISTRIBUTION OF FREE SPACE >>>
```

DSG	FREE SPACE RANGE	NUMBER OF BLOCKS	PCT OF TOTAL BLKS	<----CUMULATIVE----> NUMBER OF BLOCKS	PCT OF TOTAL BLKS	AVG SIZE OF FREE SPACE
1	322 - 512	0	0.0%	0	0.0%	
1	310 - 321	0	0.0%	0	0.0%	
1	0 - 309	21	100.0%	21	100.0%	
1	.....					114.3
2	314 - 512	0	0.0%	0	0.0%	
2	310 - 313	0	0.0%	0	0.0%	
2	0 - 309	21	100.0%	21	100.0%	
2	.....					186.5
3	318 - 512	0	0.0%	0	0.0%	
3	306 - 317	0	0.0%	0	0.0%	
3	0 - 305	32	100.0%	32	100.0%	
3	.....					190.2

Figure 238. Tuning a HIDAM database: sample 13

## Is the block size or CI size appropriate?

As a rule of thumb, use a 4 KB CI/block size for the data portion of a HIDAM. However, if the average database record length is more than 1000 bytes (that is, larger than 1/4th of the block or CI size), then an increase of the block or CI size from 4 KB to 8 KB might improve the performance of HIDAM database accesses.

In these cases, an increase of the CI size/block size from 4 KB to 8 KB can often reduce the number of I/O operations (but will increase slightly the time of an I/O operation). CI/block sizes larger than 8 KB should be an exception (for example, for very large average database record sizes).

### Discussion of the example

You can check the current block size or CI size, the number of blocks or the number of CIs in the Data Set Statistics report. You can check the average database record size in AVERAGE DATABASE RECORD SIZE in the Distribution of Database Record Sizes report. In [Figure 232 on page 636](#), AVERAGE DATABASE RECORD SIZE shows 2,317 bytes. Because this is over 1000 bytes, you can expect performance to improve by increasing the block size from 4 KB to 8 KB.

## Is the problem with long database records solved appropriately?

For HIDAM databases with a high percentage of very long database records (for example, 32 KB or more), it is difficult to achieve a low value for the average number of I/Os per database record.

Some of the actions that can be taken to limit the performance problems of long database records are:

- Use a large block or CI size (for example, 12 KB)
- Evaluate usage of database segment compression in order to reduce the average size of database records

– The following discusses the points to be careful of when using compressed segments:

Using a compression exit routine in order to store the segments on DASD in a compressed format can be useful, especially if the compression can significantly reduce the average database record size in such a way that the average number of database I/Os required to read at random all

database segments of a database record can be lowered. When using compression routines, beware of segment splits created by replace calls that extend the compressed size of a database segment. Some protection against such replace calls can be achieved by defining enough free space for non-primary data set groups.

- Evaluate storage of the most often referred-to database segments in the same block or CI as the root. The less frequently referred-to database segments can be inserted after the initial load/reload or can be stored in another data set group.
- Evaluate changes to the database design in order to reduce the average size of database records.

### Discussion of the example

You can check the average size of database records in AVERAGE DATABASE RECORD SIZE of the Distribution of Database Record Sizes report. [Figure 236 on page 643](#) shows that the average size of database records is 27,999, which is too long, and the method previously described is effective.

You can check the status of segment compression in the Variable Length Segment Statistics section of the Segment Statistics report. The following figure shows that COMPRESSION FACTOR is 0.0%, which means the segment is not compressed at all. You should review the compression routine to raise the compression ratio, which might shorten the average length of database records.

```
<<< VARIABLE LENGTH SEGMENT STATISTICS >>>
```

SEGMENT	<-----LENGTHS----->				<-----SEGMENT COUNT----->		<-COMPRESSION-->
	MIN	MAX	PFX	DATA	<MIN	=>MIN	FACTOR NAME
DEP1LEV2	220	700	6	544	0	10,290	
DEP2LEV2	50	2,500	10	1,454	0	12,000	
DEP3LEV3	4	41	6	31	0	57,600	0.0% DFSCMPX0

Figure 239. Tuning a HIDAM database: sample 14

You can calculate the average record length of the database records from the root segment to the segment type that you want to include in the primary data set by summing up the values of AVG SEGM LENGTH in the Segment Statistics report. For example, in [Figure 235 on page 639](#), if you want to include segments ROOTLEV1 and DEP1LEV2 in the primary data set group, add the sum of the products of AVG SEGM LENGTH and AVG OCCURRENCES PER RECORD for segments ROOTLEV1 and DEP1LEV2—that is, the value of CONTRIBUTION TO DB RECORD SIZE CUM SIZE, which is 430.

You can check the block size or the CI size of the current database data sets in the Data Set Statistics report. See [Figure 231 on page 635](#).

## Working on exceptions in a HISAM or SHISAM database

This guideline provides information to tune HISAM and SHISAM databases.

If the remaining database exception is AVERAGE\_DB\_RECORD\_LENGTH, see the subsequent topics.

If the remaining database exception is DATA\_SET\_EXTENTS\_AVAILABILITY or GROWING\_DBDS\_WITH\_DATA\_FULL, see [“Working on space shortage exceptions” on page 649](#).

### Average number of I/O operations per database record

An HISAM database is considered to be efficiently organized if the average number of I/O operations that are required to randomly read all database segments of one database record is low. The average number of I/Os required to read at random all database segments of one database record is one of the most important indicators for the quality of the physical organization of the HISAM database.

The average number of I/O operations is reported in the DB Tuning Statistics report. For information about generating this report, see [“Reports for database tuning” on page 629](#). Note that the HSSR Engine counts the reading of a KDSR record as a single I/O operation and ignores I/O operations that are required to access the VSAM index CIs. By looking at this average number, the database administrator can determine if the database records and their segment occurrences are stored efficiently without analyzing the entire report.

For an ideal HISAM database, this average number is 1.0. However, in a real production database, this ideal value is typically difficult to achieve and the average number of database I/Os per database record will be higher.

Numbers above 1.30 might indicate that the HISAM database is poorly organized. In this case, database administrator should ask the following questions to determine the reason for the poor organization:

- Is the KSDS record length appropriate? See [“Is the length of the KSDS record appropriate?”](#) on page 647.
- Is the ESDS CI size appropriate for the database record lengths of this DB? See [“Is the ESDS CI size appropriate for the record length of this database?”](#) on page 648.

The guideline for the KSDS record length applies to a SHISAM database and a HISAM database without an overflow data set. For HISAM database that has the overflow data set, see also [“Does the segment fit on KSDS?”](#) on page 649.

## Is the length of the KSDS record appropriate?

The database administrator needs to perform trade-offs when determining the KSDS record length for a HISAM database.

Selecting a large KSDS LRECL allows reduction of the number of database records that cannot be stored entirely in the KSDS record. This approach reduces the average number of I/Os per database record. However, selection of a KSDS LRECL that is too large might represent a waste of DASD space if a high percentage of database record does not reasonably fill the KSDS record.

### Discussion of the example

You can check the following in the Data Set Statistics report: the block size or the CI size of a database data set that is defined, the number of blocks or the number of CIs that are defined, and the logical record length. See the following figure.

```

IMS HIGH PERFORMANCE UNLOAD                                PAGE:          1
5655-E06                                                    10/05/2023  14.00.18

                                "DATA SET STATISTICS"

TYPE  DDNAME      BLOCK  RECORD
-----  -----  ----  ----
PRIM  DDHS0010     4,096   370  TESTDS.NTFC5106.DBHS0010.DDHS0010
OVFL  DDH00010     8,192   500  TESTDS.NTFC5106.DBHS0010.DDH00010

TYPE  DDNAME      SMALL  LARGE
-----  -----  ----  ----
PRIM  DDHS0010         22   202
OVFL  DDH00010         22   202

```

Figure 240. Tuning a HISAM database: sample 15

You can check the number of logical records in NUMBER OF LOGICAL RECORDS in the HISAM Statistics report. See the following figure.

"HISAM STATISTICS"

PRIMARY DD = DDHS0010

NUMBER OF LOGICAL RECORDS.....	10
NUMBER OF RECORDS WITH OVERFLOW CHAINS.....	4
NUMBER OF RECORDS WITH NO OVERFLOW CHAINS...	6
MAX NUMBER OF OVERFLOW CHAINS.....	2
MIN NUMBER OF OVERFLOW CHAINS.....	1
AVERAGE NUMBER OF OVERFLOW CHAINS.....	1.3

OVERFLOW DD = DDH00010

NUMBER OF LOGICAL RECORDS.....	5
--------------------------------	---

Figure 241. Tuning a HISAM database: sample 16

You can check the average length of the database records and distribution of database record length in the Distribution of Database Record Sizes report.

## Is the ESDS CI size appropriate for the record length of this database?

As a rule of thumb, use a 4 KB CI size for the ESDS portion of a HISAM database. However, for long database records, an increase of the ESDS CI size from 4 KB to 8 KB might improve the performance of HISAM database accesses.

### Discussion of the example

In the Data set statistics report, you can check the block size or the CI size of the database data set and the number of blocks or the number of CIs that are defined—see [Figure 240 on page 647](#). You can also check the number of logical records in the HISAM Statistics report—see [Figure 241 on page 648](#).

You can check the average size of database records in AVERAGE DATABASE RECORD SIZE of the Distribution of Database Record Sizes report—see [Figure 232 on page 636](#).

You can calculate the average record length of the database records from the root segment to the segment type that you want to include in the primary data set by summing up the values of AVG SEGM LENGTH in the Segment Statistics report. For example, in the following figure, if you want to include segment ROOTLEV1 and segment DEP1LEV2 in the primary data set, you can compare a logical record length for the primary data set (value specified in the RECORD= operand of the DATASET statement in the DBD) and the sum of the products of AVG SEGM LENGTH and AVG OCCURRENCES PER RECORD values—that is, the value of CONTRIBUTION TO DB RECORD SIZE CUM SIZE, which is 45—of segment ROOTLEV1 and segment DEP1LEV2.



"SEGMENT STATISTICS"

SEGMENT STATISTICS

SEGMENT	TOTAL NBR OF OCCURRENCES	<-----AVG OCCURRENCES-----> PER PARENT	PER RECORD	AVG SEGM LENGTH	<--CONTRIBUTION TO DB RECORD SIZE--> PCT	CUM SIZE
ROOTLEV1	10	1.0	1.0	22	5.5%	22
DEP1LEV2	10	1.0	1.0	23	5.7%	45
DEP2LEV2	11	1.1	1.1	25	6.8%	73
DEP3LEV3	9	0.8	0.9	32	7.1%	101
DEP4LEV2	11	1.1	1.1	79	21.6%	189
DEP5LEV3	9	0.8	0.9	121	27.0%	297
DEP6LEV3	11	1.0	1.1	96	26.2%	403

SEGMENT IN OVERFLOW STATISTICS

SEGMENT	<-----OVERFLOW-----> NUMBER	PCT
ROOTLEV1	N/A	N/A
DEP1LEV2	0	0.0%
DEP2LEV2	0	0.0%
DEP3LEV3	0	0.0%
DEP4LEV2	2	18.2%
DEP5LEV3	4	44.4%
DEP6LEV3	8	72.7%

TOTAL SEGMENTS = 71

<<< VARIABLE LENGTH SEGMENT STATISTICS >>>

SEGMENT	<-----LENGTHS----->				<-----SEGMENT COUNT----->		<-COMPRESSION-->
	MIN	MAX	PFX	DATA	<MIN	=>MIN	FACTOR NAME
DEP2LEV2	4	40	2	23	0	11	- 13.6% DFSCMPX0
DEP4LEV2	50	100	2	77	0	11	
DEP5LEV3	100	200	2	119	4	5	
DEP6LEV3	70	140	2	94	0	11	

Figure 242. Tuning a HISAM database: sample 17

## Does the segment fit on KSDS?

The similar sizes allow you to pick logical record lengths and CI sizes so most database records fit on the primary data set.

You want most database records to fit on the primary data set because additional read and seek operations are required to access those parts of a database record on the overflow data set. Additional reads and seeks degrade performance. If, however, most of the processing you do against a database record occurs on segments in the primary data set (in other words, your high-use segments fit on the primary data set), these considerations might not be as important.

### Discussion of the example

The number of segments in the primary data set (KSDS) and the overflow data set (ESDS) can be checked in the Segment Statistics report. See [Figure 242 on page 649](#).

## Working on space shortage exceptions

This topic discusses how to solve the space shortage exceptions.

After you complete the database tuning steps in [Chapter 46, "Database tuning guide," on page 629](#), if either of the following exceptions are reported by Policy Services, consider performing additional steps to tune the data set allocation or database partitioning:

1. DATA\_SET\_EXTENTS\_AVAILABILITY

## 2. GROWING\_DBDS\_WITH\_DATA\_FULL

If the first exception is reported but the second exception is not reported, try to remove the exceptional state by changing the allocation size of one or more of the database data sets, by adding volumes for those data sets, or by doing both. For more information, see [“Tuning data set allocation”](#) on page 650.

If the second exception is reported for a partition of a PHDAM or PHIDAM database, repartitioning is needed. For more information, see [“Managing HALDB partitions”](#) on page 650. If the second exception is reported for an HDAM or HIDAM database, consider migrating your database to HALDB. For more information, see [“Migrating to HALDB”](#) on page 650.

### **Tuning data set allocation**

For each data set of the database, the Volume and Extent Statistics section of the Diagnosis report provides an estimate about the usage of data set extents and the availability of extents on DASD volumes that are currently allocated for the data set. By looking at this section, you can determine the cause of the DATA\_SET\_EXTENTS\_AVAILABILITY exception.

The primary and secondary extent allocation size is indicated by the data element value DB\_NUM\_PRI\_SPACE or DB\_NUM\_SEC\_SPACE respectively. If either of these values are too small compared to the current data set size, increase the primary allocation size, the secondary allocation size, or both, depending on the growth rate of the data set.

If a large enough number of free extents is not available on the DASD volumes that are already allocated for the data set, add additional volumes so that the data set can be extended to hold data that can be added by application programs.

To obtain more detailed information about the data set extent usage and free extents on the volumes, use the Space Monitor utility of IMS HP Pointer Checker.

For more information about the Volume and Extent Statistics section, see [“Volume and Extent Statistics section”](#) on page 230.

### **Managing HALDB partitions**

If the database is a PHDAM or PHIDAM and exception GROWING\_DBDS\_WITH\_DATA\_FULL is reported for a data set of a partition, consider dividing the partition into two or more partitions or adding one or more partitions to move some database records to the added partitions. IBM IMS High Availability Large Database Toolkit for z/OS can help you divide and add partitions.

### **Migrating to HALDB**

If the database is an HDAM or HIDAM database and exception GROWING\_DBDS\_WITH\_DATA\_FULL is reported, the following actions might resolve this exception:

- Add one or more data set groups and move some segment types from the data set that received the exception to the new data set groups. Although this action might resolve the exception, it can also increase the average number of I/O operations per database record.
- If the addition of data set groups is not a viable solution for your installation, consider migrating the database to HALDB. IBM IMS High Availability Large Database Toolkit for z/OS can help you do this migration.

# Chapter 47. How to read syntax diagrams

The following rules apply to the syntax diagrams that are used in this information:

- Read the syntax diagrams from left to right, from top to bottom, following the path of the line. The following conventions are used:
  - The >>--- symbol indicates the beginning of a syntax diagram.
  - The ---> symbol indicates that the syntax diagram is continued on the next line.
  - The >--- symbol indicates that a syntax diagram is continued from the previous line.
  - The --->< symbol indicates the end of a syntax diagram.
- Required items appear on the horizontal line (the main path).

▶▶ *required\_item* ▶▶

- Optional items appear below the main path.

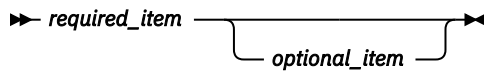

If an optional item appears above the main path, that item has no effect on the execution of the syntax element and is used only for readability.

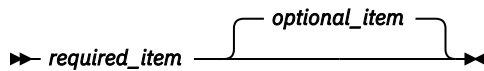

- If you can choose from two or more items, they appear vertically, in a stack.

If you *must* choose one of the items, one item of the stack appears on the main path.

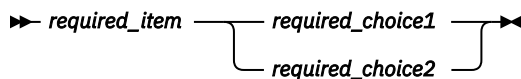

If choosing one of the items is optional, the entire stack appears below the main path.

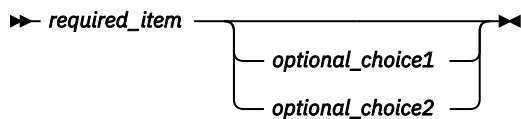

If one of the items is the default, it appears above the main path, and the remaining choices are shown below.

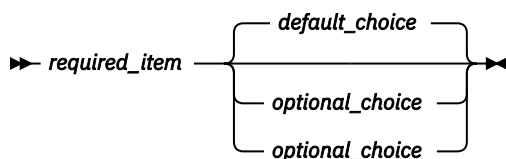

- An arrow returning to the left, above the main line, indicates an item that can be repeated.

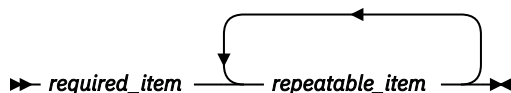

If the repeat arrow contains a comma, you must separate repeated items with a comma.

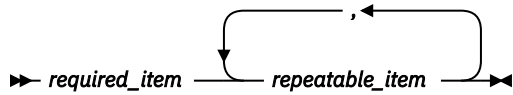

A repeat arrow above a stack indicates that you can repeat the items in the stack.

- Sometimes a diagram must be split into fragments. The syntax fragment is shown separately from the main syntax diagram, but the contents of the fragment should be read as if they are on the main path of the diagram.

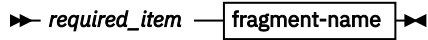

**fragment-name**

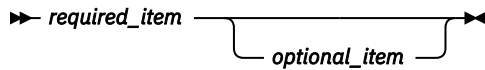

- A b symbol indicates one blank position.
- Keywords, and their minimum abbreviations if applicable, appear in uppercase. They must be spelled exactly as shown. Variables appear in all lowercase italic letters (for example, *column-name*). They represent user-supplied names or values.
- Separate keywords and parameters by at least one space if no intervening punctuation is shown in the diagram.
- Enter punctuation marks, parentheses, arithmetic operators, and other symbols exactly as shown in the diagram.
- Footnotes are shown by a number in parentheses; for example, (1).

---

## Part 9. Troubleshooting

The following topics provide troubleshooting information to diagnose and resolve IMS Database Reorganization Expert problems.

**Topics:**

- [Chapter 48, “Problem determination,” on page 655](#)
- [Chapter 49, “Messages and codes,” on page 661](#)
- [Chapter 50, “Diagnostics Aid,” on page 795](#)



---

## Chapter 48. Problem determination

Any error or warning conditions that occur in an IMS Database Reorganization Expert job result in one or more messages being issued.

When you encounter any problems, follow these steps:

1. Identify the problem by checking the job outputs.
2. If you cannot solve the problem, gather diagnostics information before you contact IBM Software Support.

### Topics:

- [“Identifying problems in Smart Reorg jobs” on page 655](#)
- [“Identifying problems in Pre-reorganization utility and Post-reorganization utility jobs” on page 656](#)
- [“Identifying problems in IPR Unload jobs” on page 657](#)
- [“Identifying problems in IPR Reload jobs” on page 657](#)
- [“Identifying problems in IPR DB Scan jobs” on page 658](#)
- [“Gathering diagnostic information” on page 658](#)

### Related reference

#### Messages

This topic describes all the messages that are issued by the Smart Reorg utility, the IPR Unload utility, the IPR Reload utility, and the IPR DB Scan utility.

---

## Identifying problems in Smart Reorg jobs

When errors occur in a Smart Reorg job, you are notified of the error by at least one WTO message and a non-zero job return code.

You can determine which process an error occurred in based on the prefix of the error message.

- Error messages that have a prefix of HPSG, HPSC, HPSU, or HPSR indicate that the error occurred in the Smart Reorg Driver or the Parallel Reorganization Service processing.
- Error messages that have a prefix of BBE or BSN indicate that the error occurred in the Conditional Reorganization Support Service.

All other prefixes indicate that the error might have occurred in other IMS Tools products that run under the Parallel Reorganization Service. In this case, see [“Messages” on page 665](#) and the problem determination topics in the information of the relevant product.

Subsections:

- [“Resolving errors in the Smart Reorg Driver or the Parallel Reorganization Service” on page 655](#)
- [“Resolving errors in the Conditional Reorganization Support Service” on page 656](#)

### Resolving errors in the Smart Reorg Driver or the Parallel Reorganization Service

Error messages that start with HPSG, HPSC, HPSU, or HPSR indicate that the error occurred in the Parallel Reorganization Service processing.

The Smart Reorg utility provides the following information to help you identify and solve error conditions:

- Messages
- Return codes
- Reason codes
- Abend codes

- Reports for problem determination

## Resolving errors in the Conditional Reorganization Support Service

Error messages that start with BBE or BSN indicate that the error occurred in the Conditional Reorganization Support Service processing.

The Smart Reorg utility provides the following information to help you identify and solve error conditions:

- Messages
- Journal messages
- Return codes
- Reason codes
- Abend codes

To resolve errors in the Conditional Reorganization Support Service:

1. First, check for any WTO messages. Check the BBE or BSN error messages and try to identify the cause of the error condition. If you specified JOURNAL=YES, additional messages might be recorded in the CRSS journal that is generated in the BBEJRNL data set. When the cause of the error is in either the DB Analyzer or the DB Sensor component, the error message that is issued by the relevant component is recorded as one or more CRSS journal messages.
2. If no errors were reported in the CRSS journal, check the Policy Services journal in the BSNJM01 data set. The Policy Services journal messages provide details about Policy Services processing, such as the content of the policy and rules that were used for the job.
3. If no error messages were recorded in either of the journal messages, the error might be caused by IMS Tools KB or by other IMS Tools products that ran within the job. If you determine that the error is due to these products or components, see the problem determination topics in the information of the relevant product.

## Identifying problems in Pre-reorganization utility and Post-reorganization utility jobs

---

When errors occur in a Pre-reorganization utility job or in a Post-reorganization utility job, you are notified of the error by at least one WTO message and a non-zero job return code.

You can determine which process an error occurred in based on the prefix of the error message.

Error messages that have a prefix of HPSG or HPSC indicate that the error occurred in Pre-reorganization utility or Post-reorganization utility processing.

The Pre-reorganization utility or the Post-reorganization utility provides the following information to help you identify and solve error conditions:

- Messages
- Return codes
- Reason codes
- Abend codes
- Reports for problem determination

All other prefixes indicate that the error might have occurred in other IMS Tools products that run under the Pre-reorganization utility or the Post-reorganization utility. In this case, see [“Messages” on page 665](#) and the problem determination topics in the information of the relevant product.

### Related reference

[Messages](#)



This topic describes all the messages that are issued by the Smart Reorg utility, the IPR Unload utility, the IPR Reload utility, and the IPR DB Scan utility.

#### Pre-reorganization utility, Post-reorganization utility, and Cleanup utility return codes

This reference topic explains the return codes of the Pre-reorganization utility, the Post-reorganization utility, and the Cleanup utility.

#### Abend codes

All IMS Database Reorganization Expert utilities issue a message before they end abnormally (abend).

#### Pre-reorganization utility reports

The Pre-reorganization utility generates reports that help you understand the conditions of the databases before reorganization.

#### Post-reorganization utility reports

The Post-reorganization utility generates reports that help you understand the condition of the databases after reorganization.

## Identifying problems in IPR Unload jobs

---

When an error occurs in an IPR Unload job, you are notified of the error by at least one WTO message and a non-zero job return code.

Error messages from the IPR Unload utility start with HPSU, HPSC, or FABH. The IPR Unload utility provides the following information to help you identify and solve error conditions:

- Messages
- Return codes
- Reason codes
- Abend codes
- Reports for problem determination

If you receive error messages when you use the API function of the IPR Unload utility, see the reports that are produced by the API function.

### **Related reference**

#### Messages

This topic describes all the messages that are issued by the Smart Reorg utility, the IPR Unload utility, the IPR Reload utility, and the IPR DB Scan utility.

#### IPR Unload utility return codes

This reference topic explains the return codes of the IPR Unload utility.

#### Abend codes

All IMS Database Reorganization Expert utilities issue a message before they end abnormally (abend).

#### IPR Unload reports

The IPR Unload utility produces the reports and statistics in the HPSOUT data set, the HPSLIST data set, and the HPSRAPC data set.

#### Reports and statistics produced by the API function

The API function produces the reports and statistics in the following data sets:

## Identifying problems in IPR Reload jobs

---

When an error occurs in an IPR Reload job, you are notified of the error by at least one WTO message and a non-zero job return code.

Error messages from the IPR Reload utility start with HPSR or HPSC. The IPR Unload utility provides the following information to help you identify and solve error conditions:

- Messages
- Return codes

- Reason codes
- Abend codes
- Reports for problem determination

#### **Related reference**

##### Messages

This topic describes all the messages that are issued by the Smart Reorg utility, the IPR Unload utility, the IPR Reload utility, and the IPR DB Scan utility.

##### IPR Reload utility return codes

This reference topic explains the return codes of the IPR Reload utility.

##### Abend codes

All IMS Database Reorganization Expert utilities issue a message before they end abnormally (abend).

##### Messages report

This report contains the messages issued by the IPR Reload utility.

##### DBRC Messages report

This report contains DBRC messages when DBRC=Y is specified for a non-HALDB.

## **Identifying problems in IPR DB Scan jobs**

---

When an error occurs in an IPR DB Scan job, you are notified of the error by at least one WTO message and a non-zero job return code.

Error messages from the IPR DB Scan utility start with HPSU, HPSC, or FABH. The IPR DB Scan utility provides the following information to help you identify and solve error conditions:

- Messages
- Return codes
- Reason codes
- Abend codes
- Reports for problem determination

#### **Related reference**

##### Messages

This topic describes all the messages that are issued by the Smart Reorg utility, the IPR Unload utility, the IPR Reload utility, and the IPR DB Scan utility.

##### IPR DB Scan utility return codes

This reference topic explains the return codes of the IPR DB Scan utility.

##### Abend codes

All IMS Database Reorganization Expert utilities issue a message before they end abnormally (abend).

##### IPR DB Scan reports

The IPR DB Scan utility produces the reports and statistics in the following data sets.

## **Gathering diagnostic information**

---

Before you report a problem to IBM Software Support, gather the appropriate diagnostic information.

The information that you need includes:

- A clear description of the problem and the steps that are required to re-create the problem, including:
  - The type of the database
  - The data set organization of the database data sets
  - Whether the database has a logical relationship
  - Whether the database has a secondary index and, if so, how many

- When specified, the control statements in HPSIN and ICEIN
- All messages that were issued as the result of the problem
  - If the problem occurs in a conditional reorganization job, attach the CRSS journal and the Policy Services journal generated by the job.
- Information about your IMS system, including the version and release of IMS, whether the database is shared among multiple IMS systems or not, and any other relevant information.
- The version, release, and PTF level of IMS Database Reorganization Expert
  - You can obtain this information by running the Diagnostics Aid of IMS Database Reorganization Expert. After running the Diagnostics Aid, attach the IMS Database Reorganization Expert Load Module APAR Status report and the IMS Database Reorganization Expert Macro APAR Status report that is generated by the Diagnostics Aid program.
- The version, release, and the PTF level of prerequisite products for IMS Database Reorganization Expert, which can include:
  - IMS HP Unload
  - IMS HP Load
  - Policy Services
  - IMS Tools KB
  - IMS Index Builder
  - IMS HP Prefix Resolution
  - IMS HP Pointer Checker
  - IMS HP Image Copy
  - IMS Library Integrity Utilities

**Related reference**

How to run Diagnostics Aid with JCL stream

To run IMS Database Reorganization Expert Diagnostics Aid (HPSCDIAG), supply an EXEC statement and a DD statement that defines the output data set.



---

## Chapter 49. Messages and codes

The following topics describe the return codes, abend codes, and messages issued during the execution of IMS Database Reorganization Expert.

### Topics:

- [“Return codes” on page 661](#)
- [“Abend codes” on page 664](#)
- [“Messages” on page 665](#)

---

### Return codes

The following topics describe the return codes of IMS Database Reorganization Expert.

#### Smart Reorg utility return codes

This reference topic explains the return codes of the Smart Reorg utility.

The Smart Reorg utility returns the return codes that are listed in the following table.

*Table 88. Return codes of the Smart Reorg utility*

Return code	Description
00	Job ended normally without any warning.
04	Warning messages are issued, but the processing completed. See the reason code in message HPSG0010W for the reason of the warnings.
08	One or more errors occurred, and the processing was aborted. See the reason code in message HPSG0011E for the reason of the errors.
12	An image copy task ended with an error or errors, but other tasks ended normally or maybe with some warnings. For necessary actions, see the explanation of message HPSG0016A.
16	A severe error including the system or a user abend occurred, and the processing was aborted. See the reason code in message HPSG0011E.

#### Pre-reorganization utility, Post-reorganization utility, and Cleanup utility return codes

This reference topic explains the return codes of the Pre-reorganization utility, the Post-reorganization utility, and the Cleanup utility.

The Pre-reorganization utility, the Post-reorganization utility, and the Cleanup utility return the return codes that are listed in the following table.

*Table 89. Return codes of the Pre-reorganization utility, the Post-reorganization utility, and the Cleanup utility*

Return code	Meaning
00	Job ended normally without any warning.
04	Warning messages are issued, but the processing completed. See the reason code in message HPSG0022W for the reason of the warnings.
08	One or more errors occurred, and the processing was aborted. See the reason code in message HPSG0023E for the reason of the errors.

Table 89. Return codes of the Pre-reorganization utility, the Post-reorganization utility, and the Cleanup utility (continued)

Return code	Meaning
12	An image copy task ended with an error or errors, but other tasks ended normally or maybe with some warnings. For necessary actions, see the explanation of message HPSG0028A.
16	A severe error including the system or a user abend occurred, and the processing was aborted. See the reason code in message HPSG0023E.

## IPR Unload utility return codes

This reference topic explains the return codes of the IPR Unload utility.

The return codes of the IPR Unload utility are as listed in the following table.

Table 90. Return codes of the IPR Unload utility

Return code	Reason code	Meaning
<b>0</b>	None	Successful completion.
<b>4</b>	The reason code is a logical sum of the following codes:	
	X' 0001'	No segment was retrieved from the database.
	X' 0004'	A sensitive logical child segment type has a logical parent's concatenated key defined as "virtual," but the BLDLPCK=YES was not specified.
	X' 0008'	A database error was detected, and the SKIPERROR option might have skipped unloading one or more database segments.
	X' 0010'	Return code 4 is received from an LMU service call.
	X' 0020'	USERHDR was specified, but the *UH format was not specified on any OUTPUT control statement.
	X' 0040'	One or more incorrect RAP chains were detected in the RAPCHECK routine, but all segments are unloaded.
	X' 0080'	ERRC04 is specified on the ITKBSRVR control statement and one or more errors occurred in IMS Tools KB Output repository processing.
<b>8</b>	None	The IPR Unload utility detected an incorrect HPSIN control statement.
<b>100 - 999</b>	None	The Type-B user exit routine requested to stop the retrieval of segments and returned this code.

If the IPR Unload utility encounters a severe error, it gets to an abend. If an error occurs in HSSR Engine, HSSR Engine abends with the abend code of 4013.

### Related reference

[Identifying problems in IPR Unload jobs](#)

When an error occurs in an IPR Unload job, you are notified of the error by at least one WTO message and a non-zero job return code.

## IPR Reload utility return codes

This reference topic explains the return codes of the IPR Reload utility.

The return codes of the IPR Reload utility are listed in the following table.

Table 91. Return codes of the IPR Reload utility

Return code	Reason code	Meaning
0	None	Successful completion.
4	The reason code is a logical sum of the following codes:	
	X' 0001'	No header record is found. This code is returned if the input unloaded data set did not have an unload-type header record. The database was successfully reloaded.
	X' 0002'	Return code 4 is received from the HDAM randomizer. The database was successfully reloaded except for the root segment and its dependent segments.
	X' 0004'	Some segments have been saved into the SEQERROR data set with the SEQERROR=SAVE option. Segments written into the SEQERROR data set can be reviewed and reinserted by a user-written program.
	X' 0008'	Although the database reloaded is involved in a logical relationship or has a secondary index, DFSURWF1 DD DUMMY is specified.
	X' 0010'	Although SEQERROR=SAVE is specified on the HPSIN DD statement, SEQERROR DD DUMMY is specified.
	X' 0020'	An inconsistent return code is received from the exit routine that is specified on the USERHDRX control statement.
	X' 0040'	No segment was read from the non-dummy input (DFSUINPT). The database is empty. <b>Tip:</b> The return code can be changed by specifying the CHKEMPTYUL statement. For more information, see <a href="#">“CHKEMPTYUL control statement”</a> on page 511.
	X' 0080'	Return code 4 is received from an LMU service call.
	X' 0200'	Although the reloaded database is involved in a secondary index, HPSRSIDX DD DUMMY is specified.
	X' 0400'	An update between unload and reload processes was found, but processing was continued by the specification of CHKUPDT=YES,WARN.
	X' 0800'	One or more errors occurred in the IMS Tools KB Output Repository processing.
	X' 1000'	API function error in the IMS Library Integrity Utilities, Integrity Checker.
	X' 2000'	Although partition initialization function is used, some partitions were not initialized by one of the following reasons: <ul style="list-style-type: none"> <li>• The flag in the RECON shows that the partition does not need to be initialized (NOPINIT).</li> <li>• The partition information is not found in the unloaded data set.</li> <li>• Although PARTINIT=YES,LPART is specified, one or more partitions are not specified on the LPART statement.</li> </ul>
	X' 4000'	The DB Sensor component returned an error code.
	X' 8000'	When you specify REPAIRILK=YES, ensure that the entire HALDB (that is, all the partitions of the HALDB) is reorganized with the REPAIRILK=YES option to avoid problems that might be caused by duplicate segment ILKs.

Table 91. Return codes of the IPR Reload utility (continued)

Return code	Reason code	Meaning
8	None	This return code is returned in one of the following cases: <ul style="list-style-type: none"> <li>An incorrect control statement was encountered. The IPR Reload utility issues a message that the user-supplied control statement contained an error.</li> <li>A library of STEPLIB is not APF-authorized. The Load module library of the IPR Reload utility must be APF-authorized.</li> </ul> The database was not reloaded.
16	None	The database was not reloaded successfully. The reload segment count was unequal to the unload count. Or the reload segment count cannot be verified because a trailer record was not found at the end of the unload data set when the unload data set must have a trailer record.
100-999	None	A user exit routine requested to stop in the middle of the reloading process and to return the return code.

## IPR DB Scan utility return codes

This reference topic explains the return codes of the IPR DB Scan utility.

The return codes of the IPR DB Scan utility are as listed in the following table.

Table 92. Return codes of the IPR DB Scan utility

Return code	Meaning
0	Successful completion.
4	Warning messages were issued, but the requested operation was completed.
8	Some requested operations were skipped or unsuccessfully run because severe errors were detected.

## Abend codes

All IMS Database Reorganization Expert utilities issue a message before they end abnormally (abend).

Each abend code corresponds to the number portion of the message ID abends that occur in HSSR Engine and some abends that occur in the IPR DB Scan utility. For example, abend code 3639 is accompanied by the error message HPSx3639E. All abends that occur in HSSR Engine have the user abend code of 4013.

If an IPR DB Scan utility job ends with a return code of 4 or higher when the ABEND=YES control statement is specified, the job ends abnormally with the user abend code of 3999.

In addition to these abend codes, the following abend codes might be issued when using the Smart Reorg utility. See the appropriate message for problem determination.

### 3198

#### Explanation

A service interface inconsistency was detected by the Conditional Reorganization Support Service (CRSS) when the Smart Reorg Driver tried to use the CRSS.

#### System action

The CRSS ends abnormally.

#### User response

This abend code indicates an internal error. Follow the problem determination procedure and collect the information that is related to the job. Contact IBM Software Support.

### 3199

#### Explanation

A service interface inconsistency was detected by the Conditional Reorganization Support Service (CRSS) when the Smart Reorg Driver tried to use the CRSS.



## System action

The CRSS ends abnormally.

## User response

This abend code indicates an internal error. Follow the problem determination procedure and collect the information that is related to the job. Contact IBM Software Support.

## System action

The Smart Reorg Driver or the CRSS ends abnormally.

## User response

This abend code indicates an internal error. Follow the problem determination procedure and collect the information that is related to the job. Contact IBM Software Support.

---

## 3200

## Explanation

The Smart Reorg Driver tried to use an unsupported function of the Conditional Reorganization Support Service (CRSS).

## Messages

---

This topic describes all the messages that are issued by the Smart Reorg utility, the IPR Unload utility, the IPR Reload utility, and the IPR DB Scan utility.

## Message format

IMS Database Reorganization Expert messages adhere to the format *XXXnnnnx*, where:

### **XXX**

Indicates the prefix that is associated with the component, utility, or product that issued the message. The following table shows which prefix is associated with each component, utility, or product.

*Table 93. Message prefix*

<b>Prefix</b>	<b>Description</b>
BBE	Indicates that the message was issued by the DB Analyzer or the DB Sensor component.
BSN	Indicates that the message was issued by Policy Services.
DFS/DSP	Indicates that the message was issued by the IMS system.
HKT	Indicates that the message was issued by IMS Tools KB.
HPSC	Indicates that the message was issued by common service components of IMS Database Reorganization Expert.
HPSG	Indicates that the message was issued by the Smart Reorg utility, the Pre-reorganization utility, or the Post-reorganization utility.
HPSR	Indicates that the message was issued by the IPR Reload utility.
HPSS	Indicates that the message was issued by the IPR DB Scan utility.
HPSU	Indicates that the message was issued by the IPR Unload utility and the IPR DB Scan utility.
IIU	Indicates that the message was issued by IMS Index Builder.
FABH	Indicates that the message was issued by the HSR Engine of IMS HP Unload.
FABJ	Indicates that the message was issued by IMS HP Image Copy.

Table 93. Message prefix (continued)

Prefix	Description
FABP	Indicates that the message was issued by IMS HP Pointer Checker.
FABY	Indicates that the message was issued by IMS HP Prefix Resolution.
FOI	Indicates that the message was issued by IMS Tools Online System Interface.

**Note:** Messages with prefixes of BSN, DFS/DSP, HKT, IIU, FABH, FABJ, FABP, and FABY prefix are not documented in this information. For information about these messages, see the publications for each product.

**nnnn**

Indicates the message number.

**x**

Indicates the severity of the message:

**A**

Indicates that the operator intervention is required before processing can continue.

**E**

Indicates that an error occurred, which might or might not require operator intervention.

**I**

Indicates that the message is informational only.

**W**

Indicates that the message is a warning to alert you to a possible error condition.

**Message description**

Each message description includes the following information:

**Explanation:**

The Explanation section explains what the message text means, why it occurred, and what its variables represent.

**System action:**

The System action section explains what the system will do in response to the event that triggered this message.

**User response:**

The User response section describes whether a response is necessary, what the appropriate response is, and how the response will affect the system or program.

**BBE messages**

Messages that are issued by the DB Sensor service and the DB Analyzer service begin with BBE.

<b>BBE0001I</b>	<b>DB ANALYZER SERVICE STARTED</b>	<b>BBE0002I</b>	<b>DB ANALYZER SERVICE ENDED</b>
<b>Explanation</b>	The DB Analyzer service started. This message is for informational purposes only.	<b>Explanation</b>	The DB Analyzer service ended. This message is for informational purposes only.
<b>System action</b>	DB Analyzer processing continues.	<b>System action</b>	DB Analyzer processing continues.
<b>User response</b>	None. This message is informational.	<b>User response</b>	None. This message is informational.

---

**BBE0003W**      **DB ANALYZER ENDED WITH WARNINGS. FUNC=*function*, RC=04, RSN=*rsn***

### Explanation

The DB Analyzer function call ended with warning conditions. The hexadecimal value *rsn* shows the reason of the warning. *function* shows the function name that is used internally by the DB Analyzer function, which is one of the following functions:

#### INIT

Creates the DB Analyzer environment

#### TERM

Deletes the DB Analyzer environment

#### ANALYZE

Creates the DB Analyzer session for the database and analyzes the database

#### PREPARE

Configures the DB Sensor environment for the Reload process

#### COMMIT

Commits the database statistics that are collected by DB Sensor during the Reload process

#### ABORT

Discards the database statistics that are collected by DB Sensor during the Reload process

#### REPORT

Prints the Diagnosis report

#### FREE

Cleans up the resources that are allocated by the preceding calls

### System action

DB Analyzer processing continues.

### User response

This message accompanies other warning or error messages. Follow the directions in the user response sections of the accompanying messages.

---

**BBE0004I**      **DB ANALYZER FUNC=*function1* RETURNED NONZERO RETURN CODE TO FUNC=*function2* OF CONDITIONAL REORG SERVICE**

### Explanation

This message shows that *function1* of DB Analyzer returned a nonzero return code to *function2* of the Conditional Reorganization Support Service (CRSS). This message is for informational purposes only.

### System action

DB Analyzer processing continues.

### User response

None. This message is informational.

---

**BBE0005E**      **LOAD FAILED. SC=*nnn*, RSN=*rsn*, MOD: *modname***

### Explanation

The DB Analyzer function failed to load the *modname* module. The hexadecimal value *nnn* shows the system completion code and the hexadecimal value *rsn* shows the associated reason code that are returned from the LOAD macro.

### System action

DB Analyzer processing ends with a return code of 8.

### User response

If the 3-byte prefix of *modname* is BSN, make sure that the load module library for IMS Tools KB is specified on the STEPLIB statement in the JCL. Otherwise, see *MVS System Codes* to determine the meaning of the system completion code. Correct the error and rerun the job. If the problem persists, contact IBM Software Support.

---

**BBE0006E**      **OPEN FAILED. DD: *ddname*, RC=*rc***

### Explanation

The DB Analyzer function failed to open the database data set that is shown by the *ddname* DD. The hexadecimal value *rc* shows the return code that is returned from the OPEN macro.

### System action

DB Analyzer processing ends with a return code of 8.

### User response

See *z/OS DFSMS Macro Instructions for Data Sets* to determine the meaning of the return code. Correct the error and rerun the job. If the error is not in the data set or your system, contact IBM Software Support.

---

**BBE0007E**      **GETMAIN FAILED. RC=*rc*, SIZE=*size*, MOD: *modname*, ERROR-ID: *error\_id***

## Explanation

The DB Analyzer function failed to obtain storage. *size* shows the size of the storage that could not be obtained. The hexadecimal value *rc* shows the return code that is returned from the GETMAIN macro. *modname* shows the name of the failed module, and *error\_id* shows the error ID that is associated with the module.

## System action

DB Analyzer processing ends with a return code of 8.

## User response

See the *z/OS MVS Assembler Services Reference* to determine the meaning of the return code. Correct the error and rerun the job. If the problem persists, contact IBM Software Support.

---

**BBE0008E**      *ddname* DD IS MISSING

## Explanation

The DB Analyzer function could not find the *ddname* DD, which is a required DD for the API call.

## System action

DB Analyzer processing ends with a return code of 8.

## User response

Specify the required DD in the JCL and rerun the job.

---

**BBE0009E**      **DEVTYPE FAILED. RC=*rc*,  
RSN=*rsn*, DD: *ddname***

## Explanation

The DB Analyzer function failed to issue the DEVTYPE macro for *ddname* DD. The hexadecimal value *rc* shows the return code and the hexadecimal value *rsn* shows the associated reason code that are returned from the DEVTYPE macro.

## System action

DB Analyzer processing ends with a return code of 8.

## User response

See *z/OS DFSMSdfp Advanced Services* to determine the meaning of the return code and the reason code. Correct the error and rerun the job. If the problem persists, contact IBM Software Support.

---

**BBE0010I**      **DB ANALYZER SESSION STARTED  
FOR DATABASE *dbdname***

## Explanation

The DB Analyzer session that is associated with the conditional reorganization session started. *dbdname* shows the name of the database that is associated with the session. This message is for informational purposes only.

## System action

DB Analyzer processing continues.

## User response

None. This message is informational.

---

**BBE0011I**      **DB ANALYZER SESSION ENDED  
FOR DATABASE *dbdname***

## Explanation

The DB Analyzer session that is associated with the conditional reorganization session ended. *dbdname* shows the name of the database that is associated with the session. This message is for informational purposes only.

## System action

DB Analyzer processing continues.

## User response

None. This message is informational.

---

**BBE0012E**      **DB ANALYZER SESSION COULD  
NOT START FOR DATABASE  
*dbdname***

## Explanation

The DB Analyzer session that is associated with the conditional reorganization session failed to start. *dbdname* shows the name of the database that is associated with the session.

## System action

DB Analyzer processing ends with a return code of 8.

## User response

This message accompanies another error message. Follow the directions in the user response section of the accompanying message, correct the error, and rerun the job.

---

**BBE0013E**      **DYNAMIC ALLOCATION FAILED.**  
**RC=rc, RSN=rsn, DD: ddname**

### Explanation

The DB Analyzer function failed to request the dynamic allocation service for *ddname* DD. The hexadecimal value *rc* shows the return code and the hexadecimal value *rsn* shows the associated reason code that are returned from the dynamic allocation service.

### System action

DB Analyzer processing ends with a return code of 8.

### User response

See the *z/OS MVS Authorized Assembler Services Guide* to determine the meaning of the return code and the reason code. Correct the error and rerun the job. If the problem persists, contact IBM Software Support.

---

**BBE0014E**      **ESTAE FAILED. RC=rc, MOD:**  
**modname**

### Explanation

The DB Analyzer function failed to establish an ESTAE routine in the *modname* module. *rc* shows the return code that is returned from the ESTAE macro.

### System action

DB Analyzer processing ends with a return code of 8.

### User response

See the *z/OS MVS Assembler Services Reference* to determine the meaning of the return code. Correct the error and rerun the job. If the problem persists, contact IBM Software Support.

---

**BBE0015E**      **DB ANALYZER ENDED WITH**  
**ERRORS. FUNC=function, RC=rc,**  
**RSN=rsn**

### Explanation

The DB Analyzer function ended with a return code that is greater than or equal to 8. *function* shows the function name that is used internally by the DB Analyzer function. The hexadecimal value *rc* shows the return code of the DB Analyzer function and the hexadecimal value *rsn* shows the error reason.

### System action

DB Analyzer processing ends with a return code of 8 or greater.

### User response

Related warning or error messages that start with BBE are issued before this message. Follow the directions in the user response sections of the accompanying messages.

---

**BBE0016W**      **DB SENSOR API CALL ENDED**  
**WITH WARNINGS. FUNC=function,**  
**RC=rc, RSN=rsn**

### Explanation

The DB Sensor function ended with a return code that is greater than or equal to 8. *function* shows the function name that is used internally by the DB Sensor function. The hexadecimal value *rc* shows the return code of the DB Sensor function and the hexadecimal value *rsn* shows the error reason.

### System action

DB Analyzer processing ends with a return code of 8.

### User response

This message accompanies other warning or error messages. Follow the directions in the user response sections of the accompanying messages.

---

**BBE0017E**      **DB SENSOR API MODULE COULD**  
**NOT BE LOADED**

### Explanation

The DB Analyzer function could not load the DB Sensor API module.

### System action

DB Analyzer processing ends with a return code of 8.

### User response

Specify the correct load libraries on the STEPLIB statement in the JCL, and rerun the job.

---

**BBE0018E**      **SENSOR DATA SERVICE FAILED.**  
**RC=rc, RSN=rsn, FUNC=function.**

### Explanation

The sensor data service function call ended with errors. *function* shows the function name that is used internally by sensor data service. The hexadecimal value *rc* shows the return code and the hexadecimal value *rsn* shows the reason code of the error.

## System action

DB Analyzer processing ends with a return code of 8.

## User response

See the *IMS Tools Base Policy Services User's Guide and Reference* to determine the meaning of the return code and reason code. Correct the error and rerun the job.

---

**BBE0019I**      **SENSOR DATA COLLECTION  
STARTED FOR *dbdname***

## Explanation

The Conditional Reorganization Support Service (CRSS) started to collect sensor data for the database. This message is for informational purposes only.

## System action

DB Analyzer processing continues.

## User response

None. This message is informational.

---

**BBE0020I**      **SENSOR DATA FOR  
[*dbdname*|*partname*] RETRIEVED.  
RSI=*record\_set\_identifier***

## Explanation

The Conditional Reorganization Support Service (CRSS) retrieved the sensor data for the database or the HALDB partition from the IMS Tools KB Sensor Data repository. If the database is a non-HALDB, *dbdname* shows the name of the database. If the database is a HALDB, *partname* shows the name of the HALDB partition. *record\_set\_identifier* shows the 16-byte hexadecimal identifier of the sensor data in the repository. This message is for informational purposes only.

## System action

DB Analyzer processing continues.

## User response

None. This message is informational.

---

**BBE0021I**      **PREPARATION FOR SENSOR  
DATA COLLECTION STARTED FOR  
*dbdname***

## Explanation

The Conditional Reorganization Support Service (CRSS) started to prepare for the sensor data collection for the reorganized database. This message is for informational purposes only.

## System action

DB Analyzer processing continues.

## User response

None. This message is informational.

---

**BBE0022I**      **PREPARATION FOR SENSOR  
DATA COLLECTION ENDED FOR  
*dbdname***

## Explanation

The Conditional Reorganization Support Service (CRSS) ended the preparation for sensor data collection for the reorganized database. This message is for informational purposes only.

## System action

DB Analyzer processing continues.

## User response

None. This message is informational.

---

**BBE0023I**      **STORING SENSOR DATA FOR  
*dbdname***

## Explanation

The Conditional Reorganization Support Service (CRSS) started to store the sensor data of the reorganized database in the IMS Tools KB Sensor Data repository. This message is for informational purposes only.

## System action

DB Analyzer processing continues.

## User response

None. This message is informational.

---

**BBE0024I**      **SENSOR DATA FOR REORGANIZED  
[*dbdname*|*partname*] RETRIEVED.  
RSI=*record\_set\_identifier***

## Explanation

The Conditional Reorganization Support Service (CRSS) retrieved the sensor data of the reorganized database or the HALDB partition from the IMS Tools KB Sensor Data repository. If the database is a non-HALDB, *dbname* shows the name of the database. If the database is a HALDB, *partname* shows the name of the HALDB partition. *record\_set\_identifier* shows the 16-byte hexadecimal identifier of the sensor data in the repository. This message is for informational purposes only.

## System action

DB Analyzer processing continues.

## User response

None. This message is informational.

---

**BBE0025I**      **COLLECTED SENSOR DATA FOR  
*dbname* IS DISCARDED**

## Explanation

The Conditional Reorganization Support Service (CRSS) discarded the sensor data of the reorganized database because the reorganization failed. This message is for informational purposes only.

## System action

DB Analyzer processing continues.

## User response

None. This message is informational.

---

**BBE0026E**      **DB ANALYZER FAILED TO  
READ SENSOR DATA FROM  
SENSOR DATA REPOSITORY FOR  
[*dbname*]*partname*]**

## Explanation

The DB Analyzer function failed to read sensor data records for the database or the HALDB partition from Sensor Data repository. If the database is a non-HALDB, *dbname* shows the name of the database. If the database is a HALDB, *partname* shows the name of the HALDB partition.

## System action

DB Analyzer processing ends with a return code of 8.

## User response

This message accompanies the BBE0018E message. Follow the directions in the user response section of the BBE0018E message.

---

**BBE0027I**      **THE DIAGNOSIS MODE IS  
SELECTED**

## Explanation

The DB Analyzer service processes in Diagnosis mode. This message is for informational purposes only.

## System action

DB Analyzer processing continues.

## User response

None. This message is informational.

---

**BBE0028I**      **IMS TOOLS KNOWLEDGE BASE  
SERVER *servername* WILL BE  
USED**

## Explanation

The IMS Tools KB server *servername* is used for the DB Analyzer service. This message is for informational purposes only.

## System action

DB Analyzer processing continues.

## User response

None. This message is informational.

---

**BBE0029I**      **SENSOR DATA FOR  
[*dbname*]*partname* RETRIEVED  
FROM REPOSITORY.  
RSI=*record\_set\_identifier***

## Explanation

The Conditional Reorganization Support Service (CRSS) retrieved the sensor data from the IMS Tools KB sensor data repository to diagnose the database or the HALDB partition. If the database is a non-HALDB, *dbname* shows the name of the database. If the database is a HALDB, *partname* shows the name of the HALDB partition. *record\_set\_identifier* shows the 16-byte hexadecimal identifier of the sensor data in the repository. This message is for informational purposes only.

### System action

DB Analyzer processing continues.

### User response

None. This message is informational.

---

**BBE0030I** THE FOLLOWING OPTIONS ARE USED FOR THE DB ANALYZER SERVICE:

### Explanation

The Conditional Reorganization Support Service (CRSS) analyzed the DB Analyzer control statement and found no errors. The BBE0031I messages are accompanied to show the DB Analyzer processing options. This message is for informational purposes only.

### System action

DB Analyzer processing continues.

### User response

None. This message is informational.

---

**BBE0031I** - keyword=value

### Explanation

This message accompanies message BBE0030I. This message shows the processing option of DB Analyzer, and is issued for each processing option. This message is for informational purposes only.

### System action

DB Analyzer processing continues.

### User response

None. This message is informational.

---

**BBE0032I** THE POLICY WILL BE SELECTED BY THE FOLLOWING OPTIONS:

### Explanation

The Conditional Reorganization Support Service (CRSS) analyzed the DB Analyzer control statements and found the policy selection criteria. The BBE0031I messages are accompanied to show the options that are specified for selecting the policy. This message is for informational purposes only.

### System action

DB Analyzer processing continues.

### User response

None. This message is informational.

---

**BBE0033I** DB ANALYZER SESSION WILL BE CREATED FOR THE RESOURCE THAT HAS THE FOLLOWING ATTRIBUTES:

### Explanation

DB Analyzer session will be created for the resource that is shown in the accompanying BBE0034I messages. This message is for informational purposes only.

### System action

DB Analyzer processing continues.

### User response

None. This message is informational.

---

**BBE0034I** - resource\_type.... resource\_name

### Explanation

These messages accompany message BBE0033I. These messages show the resource attributes for the DB Analyzer session. Possible values for *resource\_name* include:

- *dbdname*, which shows the name of the database
- *partname*, which shows the name of the HALDB partition
- *dbdtype*, which shows the database organization of the database
- *dsorg*, which shows the data set organization of the database
- *ddname*, which shows the DD name of the DBD library
- *dsname*, which shows the RECON data set name that is allocated on the RECON1 DD

These messages are for informational purposes only.

### System action

DB Analyzer processing continues.

### User response

None. This message is informational.



---

**BBE0040E THE SENSOR DATA FOR  
THE DIAGNOSIS OF [dbdname]  
partname] NOT FOUND IN  
REPOSITORY**

### Explanation

The Conditional Reorganization Support Service (CRSS) tried to retrieve the sensor data from the IMS Tools KB sensor data repository to diagnose the database or the HALDB partition, but the sensor data was not found in the repository. If the database is a non-HALDB, *dbdname* shows the name of the database. If the database is a HALDB, *partname* shows the name of the HALDB partition.

### System action

DB Analyzer processing ends with a return code of 8.

### User response

To store the sensor data in the repository, specify `DIAGDATAFROM=DBSENSOR`. Rerun the job.

---

**BBE0041E AN ERROR OCCURRED IN  
HKTIMST CALL: FUNCTION=*func*  
HKT*xnnn*E - LOCID=*aaa* RC=*bb*  
RSN=*cc* R0=*ddddddd* : *errtext***

### Explanation

An error occurred during the internal API call. *func* shows the function code.

Message `HKTxnnnE` accompanies this message. The variables shown in the `HKTxnnnE` message (*aaa*, *bb*, *cc*, *ddddddd*, and *errtext*) might be required when you contact IBM Software Support.

### System action

DB Analyzer processing ends with a return code of 8.

### User response

See the explanation of message `HKTxnnnE` in the *IMS Tools Base IMS Tools Knowledge Base User's Guide and Reference*.

---

**BBE0042E INCORRECT REORGANIZATION  
TIMESTAMP  
(X'XXXXXXXXXXXXXXXXXXXXXXXXXXXXX  
xxx') WAS RECEIVED FROM  
REPOSITORY**

### Explanation

The reorganization timestamp in the repository data set is invalid.

### System action

DB Analyzer processing ends with a return code of 8.

### User response

Run a job in Unconditional Reorganization mode to store a valid reorganization timestamp.

---

**BBE0043I UTILITY HISTORY API (HKTIMST0)  
LOAD FAILED.**

### Explanation

API module `HKTIMST0` could not be loaded. The utility history data was not retrieved from the repository.

### System action

DB Analyzer processing continues.

### User response

If the rule `IBM.LAST_REORG.10` was not used, ignore this message.

If the rule was used, ensure that the load module library of IMS Tools KB is specified on the `STEPLIB` statement in the JCL. Also ensure that your environment is at the prerequisite maintenance level.

---

**BBE0201I POLICY SERVICES INITIALIZED**

### Explanation

The Policy Services function is initialized. This message is for informational purposes only.

### System action

DB Analyzer processing continues.

### User response

None. This message is informational.

---

**BBE0202I POLICY SERVICES ENDED**

### Explanation

The Policy Services function has ended. This message is for informational purposes only.

## System action

DB Analyzer processing continues.

## User response

None. This message is informational.

---

**BBE0203W**      **POLICY SERVICES ENDED WITH WARNINGS. FUNC=*function*, RC=*rc*, RSN=*rsn***

## Explanation

The Policy Services function call ended with warning conditions. The hexadecimal value *rc* shows the return code and the hexadecimal value *rsn* shows the reason code of the warning. *function* shows the function name that is used internally by Policy Services, which is one of the following functions:

- INIT
- TERM
- ASLK
- PAEV
- ASPT
- AMIT
- AMTM
- AMGA
- AMUS
- AMP2

## System action

DB Analyzer processing continues. When the processing ends, DB Analyzer issues a return code of 4.

## User response

See the *IMS Tools Base Policy Services User's Guide and Reference* to determine the meaning of the return code and the reason code, and follow the directions in the user response sections. This message might be accompanied by other warning or error messages. The accompanying messages, if issued, are recorded in the Policy Services journal. Check the Policy Services journal. If the accompanying messages exist, follow the directions in the user response sections of the accompanying messages.

---

**BBE0204E**      **POLICY SERVICES ENDED WITH ERRORS. FUNC=*function*, RC=*rc*, RSN=*rsn***

## Explanation

The Policy Services function call ended with errors. *function* shows the function name that is used internally by Policy Services. The hexadecimal value *rc* shows the return code and the hexadecimal value *rsn* shows the reason code of the error.

## System action

DB Analyzer processing ends with a return code of 8.

## User response

See the *IMS Tools Base Policy Services User's Guide and Reference* to determine the meaning of the return code and the reason code, and follow the directions in the user response sections. This message might be accompanied by other error messages. The accompanying messages, if issued, are recorded in the Policy Services journal. Check the Policy Services journal. If the accompanying messages exist, follow the directions in the user response sections of the accompanying messages.

---

**BBE0205E**      **UNABLE TO OBTAIN RECON ID. RECON=*recon*, RC=*rc*, RSN=*rsn***

## Explanation

The DB Analyzer function failed to obtain a RECON ID from IMS Tools Knowledge Base. If DB Analyzer attempts to obtain the RECON ID from the global locale, *recon* shows BSNGLOBL. If DB Analyzer attempts to obtain the RECON ID from a RECON specific locale, *recon* shows the name of the data set that is associated with the RECON ID. The hexadecimal value *rc* shows the return code and the hexadecimal value *rsn* shows the reason code from the RECON ID retrieval service.

## System action

DB Analyzer processing ends with a return code of 8.

## User response

The probable cause of this error is that one of the following conditions occurred:

- The IMS Tools KB server is not running.
- The IMS Tools KB server repositories are not configured correctly.
- The RECON ID for the RECON data sets is not defined correctly to the Input repository.

Ensure that the IMS Tools KB server is operating correctly, that the IMS Tools KB repositories are configured correctly, and that the RECON ID is defined

correctly to the Input repository. If the problem persists, contact IBM Software Support.

---

**BBE0206E**      **DATA DICTIONARY SERVICE  
DETECTED ERRORS.**  
**FUNC=function, RC=rc, RSN=rsn**

### Explanation

One or more errors were detected when the *function* function of Data Dictionary was running. Hexadecimal values *rc* and *rsn* show the return and reason codes of the error, respectively. If the errors were detected in specific data elements, BBE0207E messages or BBE0208E messages follow this message.

### System action

DB Analyzer processing ends with a return code of 8.

### User response

Specify the correct load module library for Policy Services in your JCL, and rerun the job. If the problem persists, record all the messages that were issued by the conditional reorganization job and contact IBM Software Support.

---

**BBE0207E**      **- DATA ELEMENT: *data\_element*,  
RC=rc, RSN=rsn**

### Explanation

An error was detected while processing *data\_element*. Hexadecimal values *rc* and *rsn* show the return and reason codes of the error, respectively. The preceding message, BBE0206E, indicates the function of Data Dictionary that was in process when this error occurred.

### System action

DB Analyzer processing ends with a return code of 8.

### User response

Specify the correct load module library for Policy Services in your JCL, and rerun the job. If the problem persists, record all the messages that were issued by the conditional reorganization job, and contact IBM Software Support.

---

**BBE0208E**      **- DATA ELEMENT ID:  
*data\_element\_id*, RC=rc, RSN=rsn**

### Explanation

An error was detected while processing the data element that has *data\_element\_id*. Hexadecimal

values *rc* and *rsn* show the return and reason codes of the error, respectively. The preceding message, BBE0206E, indicates the function of Data Dictionary that was in process when this error occurred.

### System action

DB Analyzer processing ends with a return code of 8.

### User response

Specify the correct load module library for Policy Services in your JCL, and rerun the job. If the problem persists, record all the messages that were issued by the conditional reorganization job, and contact IBM Software Support.

---

**BBE0209E**      **REQUESTED POLICY *policy\_name*  
WAS NOT FOUND IN THE INPUT  
REPOSITORY**

### Explanation

The *policy\_name* policy that was requested by the user was not found in any locale of the IMS Tools KB Input repository.

### System action

DB Analyzer processing ends with a return code of 8.

### User response

Determine if the correct policy name was specified for the Conditional Reorganization Support Service (CRSS) input, and determine if the specified policy is imported in the IMS Tools KB repository. Correct the error, and rerun the job.

---

**BBE0211I**      **REORGANIZATION NEED WAS  
DETECTED FOR [REORGANIZED]  
[*dbdname*|*partname*]**

### Explanation

The Conditional Reorganization Support Service (CRSS) diagnosed the database or the partition and determined that the database or the HALDB partition needs to be reorganized. If the database is a non-HALDB, *dbdname* shows the name of the database. If the database is a HALDB, *partname* shows the name of the HALDB partition. This message is for informational purposes only.

### System action

DB Analyzer processing continues.

## User response

None. This message is informational.

---

**BBE0212I**      **CRITICAL EXCEPTIONS WERE  
DETECTED FOR [REORGANIZED]  
[dbdname]partname]**

## Explanation

The Conditional Reorganization Support Service (CRSS) diagnosed the database or the partition and detected one or more critical-level database exceptions. If the database is a non-HALDB, *dbdname* shows the name of the database. If the database is a HALDB, *partname* shows the name of the HALDB partition. This message is for informational purposes only.

## System action

DB Analyzer processing continues.

## User response

None. This message is informational.

---

**BBE0213I**      **SEVERE EXCEPTIONS WERE  
DETECTED FOR [REORGANIZED]  
[dbdname]partname]**

## Explanation

The Conditional Reorganization Support Service (CRSS) diagnosed the database or the partition and detected one or more severe-level database exceptions. If the database is a non-HALDB, *dbdname* shows the name of the database. If the database is a HALDB, *partname* shows the name of the HALDB partition. This message is for informational purposes only.

## System action

DB Analyzer processing continues.

## User response

None. This message is informational.

---

**BBE0214I**      **WARNING EXCEPTIONS WERE  
DETECTED FOR [REORGANIZED]  
[dbdname]partname]**

## Explanation

The Conditional Reorganization Support Service (CRSS) diagnosed the database or the partition and detected one or more warning-level database

exceptions. If the database is a non-HALDB, *dbdname* shows the name of the database. If the database is a HALDB, *partname* shows the name of the HALDB partition. This message is for informational purposes only.

## System action

DB Analyzer processing continues.

## User response

None. This message is informational.

---

**BBE0215I**      **NO EXCEPTION WAS DETECTED  
FOR [REORGANIZED] [dbdname]  
partname]**

## Explanation

The Conditional Reorganization Support Service (CRSS) diagnosed the database or the partition and detected no exceptions. If the database is a non-HALDB, *dbdname* shows the name of the database. If the database is a HALDB, *partname* shows the name of the HALDB partition. This message is for informational purposes only.

## System action

DB Analyzer processing continues.

## User response

None. This message is informational.

---

**BBE0216I**      **SENSOR DATA FOR [dbdname]  
partname] IS EVALUATED  
AGAINST THE POLICY**

## Explanation

The Conditional Reorganization Support Service (CRSS) evaluated the sensor data that was collected from the database or the HALDB partition by using the policy. If the database is a non-HALDB, *dbdname* shows the name of the database. If the database is a HALDB, *partname* shows the name of the HALDB partition. This message is for informational purposes only.

## System action

DB Analyzer processing continues.

## User response

None. This message is informational.

**BBE0217I      SENSOR DATA FOR REORGANIZED  
[dbdname|partname] IS  
EVALUATED AGAINST THE POLICY**

**Explanation**

The CRSS evaluated the sensor data collected from the reorganized database or the reorganized HALDB partition by using the policy. If the database is a non-HALDB, *dbdname* shows the name of the database. If the database is a HALDB, *partname* shows the name of the HALDB partition. This message is for informational purposes only.

**System action**

DB Analyzer processing continues.

**User response**

None. This message is informational.

**BBE0218I      KEYLABEL DOES NOT MATCH FOR  
AT LEAST ONE DBDS**

**Explanation**

The Conditional Reorganization Support Service (CRSS) compared the key labels of the database data sets with the key labels defined in the RACF data set profile, and detected differences in at least one of the database data sets.

**System action**

DB Analyzer processing continues.

**User response**

None. This message is informational.

**BBE0219E      [ALLOCATION | DELETION] OF  
DATA SETS USED FOR KEYLABEL  
CHECK FAILED**

**Explanation**

An error occurred while allocating or deleting the work data sets for obtaining key labels.

**System action**

DB Analyzer processing ends with a return code of 8.

**User response**

See the messages that were issued from the IDCAMS program, and identify the cause of the error. The messages are printed in the Data Set Allocation Error

- KEYLABEL report or the Data Set Deletion Error - KEYLABEL report.

**BBE0300I      DIAGNOSIS REPORT GENERATION  
STARTED FOR dbdname**

**Explanation**

The Conditional Reorganization Support Service (CRSS) started to create the Diagnosis report for the database. This message is for informational purposes only.

**System action**

DB Analyzer processing continues.

**User response**

None. This message is informational.

**BBE0301I      DIAGNOSIS REPORT GENERATION  
ENDED FOR dbdname**

**Explanation**

The Conditional Reorganization Support Service (CRSS) created the Diagnosis report for the database. This message is for informational purposes only.

**System action**

DB Analyzer processing continues.

**User response**

None. This message is informational.

**BBE0302E      DIAGNOSIS REPORT GENERATION  
IS STOPPED FOR [dbdname]  
partname]**

**Explanation**

The DB Analyzer function stopped writing the Diagnosis report for the database or the HALDB partition to the BBERPRT DD and to the IMS Tools KB Output repository. If the database is a non-HALDB, *dbdname* shows the name of the database. If the database is a HALDB, *partname* shows the name of the HALDB partition.

**System action**

DB Analyzer processing ends with a return code of 8.

## User response

This message accompanies other warning or error messages. Follow the directions in the user response sections of the accompanying messages.

---

**BBE0303W**      **CSVQUERY FAILED. RC=*rc*, MOD:  
*modname***

## Explanation

The CSVQUERY macro failed for the *modname* module. The hexadecimal value *rc* shows the return code that is returned from the macro.

## System action

DB Analyzer processing continues, but no reports are stored in the IMS Tools KB Output repository.

## User response

See the *z/OS MVS Assembler Services Reference* to determine the meaning of the return code. If necessary, correct the warning condition and rerun the job.

---

**BBE0304W**      **ERROR OCCURRED IN ACCESSING  
THE OUTPUT REPOSITORY.  
FUNC=*function*, RC=*rc*, RSN=*rsn***

## Explanation

An error occurred while accessing the IMS Tools KB Output repository. The hexadecimal value *rc* shows the return code and the hexadecimal value *rsn* shows the associated reason code that are returned from IMS Tools KB.

## System action

DB Analyzer processing continues. If the return code is equal to or greater than 8, no reports are stored in the IMS Tools KB Output repository.

## User response

If you want to store the reports in the IMS Tools KB Output repository, take one of the following actions:

- If messages BBE0306W, BBE0307W, or BBE0308W, which describe the cause of the error, are issued after this message, see the explanation sections of those messages.
- If those messages are not issued, check the return code and the reason code that are specified in this message. For the description of the codes, see the *IMS Tools Base IMS Tools Knowledge Base User's Guide and Reference*.

---

**BBE0305W**      **- DBD: *dbdname*, PART: *partname*,  
REPORT: *report\_name***

## Explanation

This message follows the BBE0304W message and shows which report is processed.

## System action

See the system action section of the BBE0304W message.

## User response

See the user response section of the BBE0304W message.

---

**BBE0306W**      **RECON ENTRY WAS NOT FOUND  
IN ITKB**

## Explanation

The RECON entry was not found in the IMS Tools KB information management environment.

## System action

DB Analyzer processing continues, but no reports are stored in the IMS Tools KB Output repository.

## User response

If you want to store reports in the IMS Tools KB Output repository, check the RECON information in the IMS Tools Knowledge Base panel of the ISPF dialog and add a RECON environment.

For information about the IMS Tools Knowledge Base panel and about adding the RECON environment, see the *IMS Tools Base IMS Tools Knowledge Base User's Guide and Reference* or the *IMS Tools Base Configuration Guide*.

---

**BBE0307W**      **IMS DB REORGANIZATION  
EXPERT IS NOT REGISTERED  
WITH ITKB**

## Explanation

IMS Database Reorganization Expert was not defined in the IMS Tools KB information management environment as a product that can store reports in the IMS Tools KB Output repository.

## System action

DB Analyzer processing continues, but reports that are produced by IMS Database Reorganization Expert are not stored in the IMS Tools KB Output repository.

## User response

If you want to store reports in the IMS Tools KB Output repository, check the listing of the registered products and register the IMS Database Reorganization Expert product by using the IMS Tools KB product administration utility (HKTAPRA0). For more information, see the *IMS Tools Base IMS Tools Knowledge Base User's Guide and Reference* or the *IMS Tools Base Configuration Guide*.

---

**BBE0308W THE REPORT IS NOT DEFINED IN ITKB**

## Explanation

The report was not defined in the IMS Tools KB information management environment.

## System action

DB Analyzer processing continues, but the report is not stored in the IMS Tools KB Output repository.

## User response

If you want to store the report in the IMS Tools KB Output repository, check the listing of the registered reports and register the report by using the IMS Tools KB product administration utility (HKTAPRA0). For more information, see the *IMS Tools Base IMS Tools Knowledge Base User's Guide and Reference* or the *IMS Tools Base Configuration Guide*.

---

**BBE0309W OPEN FAILED. RC=*rc*, DD: *ddname***

## Explanation

The DB Analyzer failed to open *ddname* DD. The hexadecimal value *rc* shows the return code that is returned from the OPEN macro.

## System action

DB Analyzer processing continues, but no output is written to *ddname* DD. When the processing ends, DB Analyzer issues a return code of 4.

## User response

See *z/OS DFSMS Macro Instructions for Data Sets* to determine the meaning of the return code. If necessary, correct the warning condition and rerun the job.

---

**BBE0310W GETMAIN FAILED. RC=*rc*, SIZE=*size*, MOD: *modname*, ERROR-ID: *error\_id***

## Explanation

The DB Analyzer function failed to obtain storage. *size* shows the size of the storage that could not be obtained. The hexadecimal value *rc* shows the return code that is returned from the GETMAIN macro. *modname* shows the name of the failed module, and *error\_id* shows the error ID that is associated with the module.

## System action

DB Analyzer processing continues. When the processing ends, DB Analyzer issues a return code of 4. DB Analyzer does not write or store the Diagnosis report in the Output repository.

## User response

See the *z/OS MVS Assembler Services Reference* to determine the meaning of the return code. If this problem is due to a lack of storage, increase the region size by specifying a larger value for the REGION parameter in the JCL and rerun the job. If this problem is due to other conditions, contact IBM Software Support.

---

**BBE0311W THE ITKB ENVIRONMENT IS NOT INITIALIZED**

## Explanation

The IMS Tools KB information management environment has not been initialized.

## System action

DB Analyzer processing continues. When the processing ends, DB Analyzer issues a return code of 4. The reports are not stored in the IMS Tools KB Output repository.

## User response

This message accompanies other warning or error messages. Follow the directions in the user response sections of the accompanying messages. If necessary, correct the error and rerun the job.

---

**BBE0312I THE *report\_name* REPORT IS NOT DEFINED IN ITKB**

## Explanation

The *report\_name* report is not defined in the IMS Tools KB information management environment.

## System action

DB Analyzer processing continues, but the report is not stored in the IMS Tools KB Output repository.

## User response

None. This message is informational.

---

**BBE0315I**      **DIAGNOSIS REPORT IS  
STORED IN REPOSITORY WITH  
REPORT COMPLETION CODE  
OF *report\_completion\_code* FOR  
[*dbdname*]*partname*]**

## Explanation

DB Analyzer stored the Diagnosis report for the database or the HALDB partition in the Output repository. The decimal value *report\_completion\_code* shows the report completion code, which is 000 or 004.

## System action

DB Analyzer processing continues.

## User response

For the meaning of the report completion code, see Table 30 on page 209.

---

**BBE0316A**      **DIAGNOSIS REPORT IS  
STORED IN REPOSITORY WITH  
REPORT COMPLETION CODE  
OF *report\_completion\_code* FOR  
[*dbdname*]*partname*]**

## Explanation

DB Analyzer stored the Diagnosis report for the database or the HALDB partition in the Output repository. The decimal value *report\_completion\_code* shows the report completion code, which is 008 or greater.

## System action

DB Analyzer processing continues.

## User response

Check the Summary of Policy Evaluation section of the report to understand what kind of database exceptions remain and to determine whether you need to manually tune the database. For the meaning of the report completion code, see [Table 30 on page 209](#).

---

**BBE0320E**      **UNSUPPORTED KEYWORD  
*keyword* IS SPECIFIED**

## Explanation

The *keyword* keyword was specified in the (CONDREORG) block of the HPSIN DD statement, but this keyword is not supported.

## System action

DB Analyzer processing ends with a return code of 16.

## User response

Correct the invalid keyword in the (CONDREORG) block of the HPSIN DD statement, and rerun the job.

---

**BBE0321E**      **PARAMETER SPECIFIED ON THE  
*keyword* KEYWORD IS TOO LONG**

## Explanation

The parameter that is specified for the *keyword* keyword in the (CONDREORG) block of the HPSIN DD statement is too long.

## System action

DB Analyzer processing ends with a return code of 16.

## User response

Correct the invalid parameter for the keyword in the (CONDREORG) block of the HPSIN DD statement, and rerun the job.

---

**BBE0322E**      **VALUE MUST BE *text* FOR THE  
*keyword* KEYWORD**

## Explanation

The parameter that is specified for the *keyword* keyword in the (CONDREORG) block of the HPSIN DD statement is incorrect. *text* shows one of the following messages:

### **SPECIFIED**

The value for *keyword* is missing.

### **EITHER YES OR NO**

The value must be either YES or NO.

### **ONE OF DBTYPE, DBDNAME, AND NAME**

The value must be DBTYPE, DBDNAME, or NAME.

### **EITHER DBSENSOR OR REPOSITORY**

The value must be DBSENSOR or REPOSITORY.



## System action

DB Analyzer processing ends with a return code of 16.

## User response

Correct the invalid parameter for the keyword in the (CONDREORG) block of the HPSIN DD statement, and rerun the job.

---

**BBE0323E**      **THE *keyword* KEYWORD IS SPECIFIED MORE THAN ONCE**

---

## Explanation

The *keyword* keyword is specified more than once in the (CONDREORG) block of the HPSIN DD statement.

## System action

DB Analyzer processing ends with a return code of 16.

## User response

Correct the specification of the duplicate keyword in the (CONDREORG) block of the HPSIN DD statement, and rerun the job.

---

**BBE0324E**      **POLICYNM MUST BE SPECIFIED FOR POLICYBY=NAME**

---

## Explanation

POLICYBY=NAME is specified in the (CONDREORG) block of the HPSIN DD statement, but the POLICYNM keyword is not specified. POLICYNM is required when specifying POLICYBY=NAME.

## System action

DB Analyzer processing ends with a return code of 16.

## User response

Add the POLICYNM keyword to the (CONDREORG) block of the HPSIN DD statement, and rerun the job.

---

**BBE1201W**      **DB SENSOR ENDED WITH WARNINGS IN FUNC=*function*. RC=*return\_code***

---

## Explanation

The DB Sensor function ended with warning conditions. *function* indicates the name of the internal function that was used by DB Sensor.

## System action

DB Sensor processing ends with a return code of 4.

## User response

Check the warning messages that were issued before this message. If necessary, correct the warning conditions and rerun the job.

---

**BBE1202E**      **DB SENSOR COULD NOT OBTAIN THE CORRECT STATISTICS BECAUSE FSE OR FSEAP IS NOT CORRECT**

---

## Explanation

The DB Sensor function could not get the correct statistics because FSE or FSEAP is not correct. The error in FSE or FSEAP might have been caused because the database was being updated.

## System action

DB Sensor processing ends with a return code of 8.

## User response

None.

---

**BBE1322I**      **TOSI IS NOT ACTIVE**

---

## Explanation

The IMS Tools Online System Interface (TOSI) is not active in IMS control regions.

## System action

DB Sensor processing continues, however, DB Sensor does not retrieve the latest VSAM statistics information.

## User response

You can ignore this message if the database is offline or if the database is an OSAM database.

If the database is a VSAM database and if it is online, values for some sensor data elements might contain old data (that is, data from before the database was made online). To obtain the most recent VSAM statistics, activate TOSI in IMS control regions. For a list of sensor data elements that might contain old data, see [“TOSIXCFGRP control statement” on page 161](#).

---

**BBE1323I**      ***ddname* DD IS NOT USED IN ANY OF THE IMS CONTROL REGIONS**

---

## Explanation

IMS control regions are running. However, the database that is specified by the indicated DD is not

made available to the IMS control regions or the DL/I separate address spaces (DLISASs). The database is offline, or is not allocated or opened in the IMS control regions or the DLISASs.

### System action

DB Sensor obtains space utilization information about the database data set from the system catalog and VTOC without using IMS Tools Online System Interface (TOSI) due to the condition described in the explanation section. DB Sensor processing continues.

### User response

None. This message is informational.

---

**BBE1324I DB SENSOR WAS NOT DEFINED IN ITKB**

### Explanation

IMS Database Solution Pack or IMS Database Utility Solution was not defined in the IMS Tools Knowledge Base information management environment as a product that can store reports in the IMS Tools KB Output repository.

### System action

DB Sensor processing continues, but DB Sensor does not store any reports in the IMS Tools KB Output repository.

### User response

If you want to store reports in the IMS Tools KB Output repository, check the listing of the registered products and register the IMS Database Solution Pack product or IMS Database Utility Solution product by using the IMS Tools KB product administration utility (HKTAPRA0). For more information, see the *IMS Tools Base IMS Tools Knowledge Base User's Guide and Reference* or the *IMS Tools Base Configuration Guide*.

---

**BBE1325I RECON ENTRY WAS NOT FOUND IN ITKB**

### Explanation

The RECON entry was not defined in your IMS Tools Knowledge Base information management environment.

### System action

DB Sensor processing continues, but DB Sensor does not store any reports in the IMS Tools KB Output repository.

### User response

If you want to store the reports in the IMS Tools KB Output repository, check the RECON information in the IMS Tools Knowledge Base panel of the ISPF dialogue and add the RECON environment. For information about the IMS Tools Knowledge Base panel and about adding the RECON environment, see the *IMS Tools Base IMS Tools Knowledge Base User's Guide and Reference* or the *IMS Tools Base Configuration Guide*.

---

**BBE1326I THE REPORT WAS NOT DEFINED IN ITKB**

### Explanation

The report was not defined in the IMS Tools Knowledge Base information management environment.

### System action

DB Sensor processing continues, but DB Sensor does not store the report in the IMS Tools KB Output repository.

### User response

If you want to store the report in the IMS Tools KB Output repository, check the listing of the registered reports and register the report by using the IMS Tools KB product administration utility (HKTAPRA0). For more information, see the *IMS Tools Base IMS Tools Knowledge Base User's Guide and Reference* or the *IMS Tools Base Configuration Guide*.

---

**BBE1327I AN ERROR OCCURRED IN ACCESSING OUTPUT REPOSITORY  
FUNC: function, RC: rc, RSN: rsn**

### Explanation

An error occurred while accessing the IMS Tools KB Output repository. The hexadecimal value *rc* shows the return code and the hexadecimal value *rsn* shows the associated reason code that are returned from IMS Tools KB.

### System action

DB Sensor processing continues. If the return code is equal to or greater than 8, DB Sensor does not store its reports in the IMS Tools KB Output repository.

### User response

If you do not want to store the reports in the IMS Tools KB Output repository, ignore the error.

If you want to store the reports in the IMS Tools KB Output repository, complete the appropriate action:

- If one or more of the messages BBE1324I, BBE1325I, or BBE1326I are issued after this message, see the explanation sections for those messages.
- If these messages are not issued, check the return code and the reason code that are shown in this message. For the description of the codes, see the *IMS Tools Base IMS Tools Knowledge Base User's Guide and Reference*.

---

**BBE1328I**      **DB: *dbdname*, PART: *partname*, REPORT: *report\_name***

### Explanation

This message follows the BBE1327I message.

### System action

DB Sensor processing continues. If the return code in the BBE1327I message is equal to or greater than 8, DB Sensor does not store the *report\_name* report for the database and the partition that are shown in this message.

### User response

See the description for message BBE1327I.

---

**BBE1331I**      **SENSOR DATA FOR SOME DATA ELEMENTS ARE NOT STORED BECAUSE THEY ARE NOT IN THE DATA DICTIONARY.**

### Explanation

The sensor data for the following data elements was not stored because the following data elements are not defined in the Policy Services Data Dictionary:

- DB\_PCT\_NUM\_FRAGD\_FSE
- DB\_AVG\_NUM\_FRAGD\_FSE
- DB\_PCT\_NUM\_NOREUSE\_FSE
- DB\_FLAG\_SENSOR\_HOME

### System action

DB Sensor stores sensor data for other data elements and continues processing.

### User response

To store sensor data for the data elements that are listed in the Explanation section, one of the currently supported versions of IMS Tools Base is required.

If you do not use these data elements, ignore this message.

---

**BBE1332I**      **SOME OF SENSOR DATA ELEMENTS ARE NOT STORED BECAUSE OF INVALID VSAM STATISTIC.**

### Explanation

The following sensor data elements are not stored because VSAM statistic values in the catalog are invalid.

- DB\_UNUSED\_BYTES
- DB\_PCT\_UNUSED\_BYTES
- DB\_NUM\_CI\_SPLIT
- DB\_PCT\_NUM\_CI\_SPLIT
- DB\_NUM\_CA\_SPLIT
- DB\_PCT\_NUM\_CA\_SPLIT
- DBX\_NUM\_IPS
- DBX\_NUM\_IPS\_OVFL
- DBX\_PCT\_IPS\_OVFL
- DBX\_UNUSED\_BYTES
- DBX\_PCT\_UNUSED\_BYTES
- DBX\_NUM\_CI\_SPLIT
- DBX\_PCT\_NUM\_CI\_SPLIT
- DBX\_NUM\_CA\_SPLIT
- DBX\_PCT\_NUM\_CA\_SPLIT

For more information about invalid values in VSAM statistics, refer to the description of APAR II14008 in the IBM Support Web site.

Another BBE1332I message follows this message. The second BBE1332I message identifies the data set whose VSAM statistics values are invalid.

### System action

DB Sensor stores sensor data elements except for the listed sensor data elements and continues processing.

### User response

To store the listed sensor data elements, refer to the description of APAR II14008 and correct the statistic values of the VSAM data set.

---

**BBE1333I**      **DB SENSOR IS RETRYING SENSOR DATA COLLECTION FOR INDEX DATABASE *dbdname* DD *ddname*.**

## Explanation

DB Sensor is retrying to collect sensor data because some of the VSAM statistics information retrieved from the z/OS catalog has inconsistencies. The possible cause could be that the database is being updated by an IMS application and, therefore, VSAM statistics in the z/OS catalog is also being updated.

## System action

DB Sensor continues processing.

## User response

None. This message is informational.

---

<b>BBE1350I</b>	<b>DB SENSOR STORED SENSOR DATA FOR DATABASE <i>dbname</i> [, PARTITION <i>partname</i> ]</b>
-----------------	---

## Explanation

DB Sensor stored the sensor data for the indicated database and HALDB partition in the Sensor Data repository of IMS Tools KB.

## System action

DB Sensor processing continues.

## User response

None. This message is informational.

---

<b>BBE1401E</b>	<b>DB SENSOR ENDED WITH ERRORS IN FUNC=<i>function</i>. RC=<i>return_code</i></b>
-----------------	---

## Explanation

The DB Sensor function ended with errors and could not gather the statistics data.

## System action

DB Sensor processing ends with a return code of 8 or 16.

## User response

Check the error messages that are issued before this message. If necessary, correct the errors and rerun the job. If the problem persists, contact IBM Software Support.

---

<b>BBE1402E</b>	<b>INPUT PARAMETER <i>parameter</i> IS NOT CORRECT. FUNC=<i>function</i></b>
-----------------	--

## Explanation

The input *parameter* parameter for an API macro is not correct.

## System action

DB Sensor processing ends with a return code of 8.

## User response

This is probably an internal error. Contact IBM Software Support.

---

<b>BBE1403E</b>	<b>THE DB ORGANIZATION (<i>organization</i>) OF DATABASE <i>dbname</i> IS NOT SUPPORTED</b>
-----------------	---

## Explanation

The database organization of the *dbname* database is not supported.

## System action

DB Sensor processing ends with a return code of 8.

## User response

This is probably an internal error. Contact IBM Software Support.

---

<b>BBE1404E</b>	<b><i>ddname</i> DD IS MISSING</b>
-----------------	------------------------------------

## Explanation

A data set is not allocated to *ddname* DD.

## System action

DB Sensor processing ends with a return code of 8.

## User response

Specify a data set name on the *ddname* DD statement and rerun the job.

---

<b>BBE1405E</b>	<b>DB SENSOR WAS CALLED IMPROPERLY BY FUNC=<i>function</i></b>
-----------------	--

## Explanation

The *function* function called the DB Sensor function improperly.

## System action

DB Sensor processing ends with a return code of 8.

## User response

Contact IBM Software Support.

---

**BBE1406E**      **DB SENSOR RECEIVED BROKEN  
CI/BLOCK AS RBN=*rbn* OF *ddname*  
DD**

## Explanation

The CI/Block cannot be analyzed because the CI/Block that was passed to the DB Sensor function as the CI/Block for *rbn* of *ddname* DD is broken.

## System action

DB Sensor processing ends with a return code of 8.

## User response

Contact IBM Software Support.

---

**BBE1407E**      **THE SENSOR DATA PROCESS WAS  
CANCELED**

## Explanation

An error occurred and the sensor data process was canceled.

## System action

DB Sensor processing ends with a return code of 8.

## User response

Check the error messages that were issued before this message. If the problem persists, contact IBM Software Support.

---

**BBE1408E**      **BLOCK ANALYSIS IS  
INCOMPLETE. TASK-ID: *task\_id***

## Explanation

The block analysis that was run by the SCAN task and that is identified by *task\_id* is incomplete because the task failed with errors.

## System action

DB Sensor processing ends with a return code of 8.

## User response

Check the error messages that are issued before this message. Correct the errors and rerun the job. If the problem persists, contact IBM Software Support.

---

**BBE1409E**      **DB SENSOR SHOULD BE CALLED  
WITH FUNC=*function***

## Explanation

The *function* function should have called the DB Sensor function, but the call was not made.

## System action

DB Sensor processing ends with a return code of 8.

## User response

Contact IBM Software Support.

---

**BBE1410E**      **DASD VOLUME (*volume\_serial*) OF  
*ddname* DD IS UNAVAILABLE**

## Explanation

The DASD volume that contains DBDS *ddname* DD is not available. *volume\_serial* shows the volume serial number.

## System action

DB Sensor processing ends with a return code of 8.

## User response

Make the DASD volume available in the system, and specify the correct data set for *ddname* DD.

---

**BBE1411E**      **CATALOG SEARCH PROCESS FOR  
*ddname* DD FAILED BECAUSE [CSI  
FAILED WITH RC=*rc*, RSN=*rsn*  
| CATALOG HAS NO DATA  
COMPONENT | DCOLLECT FAILED  
WITH RC=*rc*]**

## Explanation

The DB Sensor function failed to obtain the space utilization information from the catalog of the *ddname* DD data set.

## System action

DB Sensor processing ends with a return code of 8.

## User response

Catalog the data set information correctly and rerun the job. If the problem persists, contact IBM Software Support.

---

**BBE1412E**      **DB SENSOR ENDED WITH ERRORS. FUNC=*function*, RC=*rc*, RSN=*rsn***

### Explanation

The DB Sensor function ended with errors.

### System action

DB Sensor processing ends with a return code of 8 or 16.

### User response

Check the error messages that are issued before this message and follow the user response sections of those messages. If necessary, correct the errors and rerun the job. If the problem persists, contact IBM Software Support.

---

**BBE1413E**      **DB SENSOR IS NOT APF-AUTHORIZED**

### Explanation

The load module library that includes DB Sensor is not APF-authorized.

### System action

DB Sensor processing ends with a return code of 8.

### User response

APF-authorize all the data sets that are concatenated to the STEPLIB or the JOBLIB DD.

---

**BBE1429E**      **PARTITION *partname* IS DISABLED OR NOT FOUND IN THE RECON DATA SETS.**

### Explanation

The indicated HALDB partition is either disabled or not found in the RECON data sets.

### System action

DB Sensor processing ends with return code 8.

### User response

Specify the correct partition name for the PART keyword in the BBESIN data set and rerun the job.

---

**BBE1440E**      **TOSI API FUNCTION=*function* FAILED, RC=*rc*, RSN=*rsn***

### Explanation

An error occurred during IMS Tools Online System Interface (TOSI) processing. *function* is the TOSI function code, and *rc* and *rsn* are the return code and the reason code from TOSI.

### System action

DB Sensor processing ends with a return code of 8.

### User response

See the IMS Tools Online System Interface messages (FOIxxxxx) that were issued in the IMS control regions where the IMS Tools Online System Interface is active.

---

**BBE1441E**      **TOSI API FUNCTION=*function* FAILED FOR DBD=*dbdname*, RC=*rc*, RSN=*rsn***

### Explanation

An error occurred during IMS Tools Online System Interface (TOSI) processing. *function* is the TOSI function code, and *rc* and *rsn* are the return code and the reason code from TOSI.

### System action

DB Sensor processing ends with a return code of 8.

### User response

See the IMS Tools Online System Interface messages (FOIxxxxx) that were issued in the IMS control regions where the IMS Tools Online System Interface is active.

---

**BBE1442E**      **THE VSAMSTAT COMMAND FAILED FOR DBD=*dbdname*, DD=*ddname*, RC=*rc*, RSN=*rsn***

### Explanation

DB Sensor issued the VSAMSTAT action command to obtain the latest VSAM statistics of the IMS full-function database data set by using IMS Tools Online System Interface (TOSI). However, the TOSI processing did not complete successfully in one or more IMS control regions.

### System action

DB Sensor processing ends with a return code of 8.

## User response

See the IMS Tools Online System Interface messages (FOIxxxxx) that were issued in the IMS control regions where the IMS Tools Online System Interface is active.

---

**BBE1444E**      **TOSI IS NOT AT THE  
REQUIRED MAINTENANCE LEVEL:**  
*reason\_code*

## Explanation

The version and release of IMS Tools Online System Interface (TOSI) that was used in the DB Sensor job, in the IMS control regions, or both are lower than the required maintenance level. *reason\_code* has the following meaning:

---

Reason code	Meaning
0001	The version of IMS Tools Online System Interface is not at the required maintenance level to support the VSAMSTAT command. One of the currently supported versions of IMS Tools Base is required.
0002	The version of IMS Tools Online System Interface is not at the required maintenance level to run the VSAMSTAT command against VSAM linear data sets. IMS Tools Base 1.6 with APAR PH23664 or later is required.

---

## System action

DB Sensor processing ends with a return code of 8.

## User response

Use IMS Tools Online System Interface that is at the required maintenance level.

---

**BBE1445E**      **CONNECTION TO THE ITKB  
SERVER FAILED**

## Explanation

The connection to the IMS Tools KB server failed. This message might be issued for the following reasons:

- The server configuration is incomplete.
- The server is not started.
- The server XCF group name that is specified by the ITKBSRVR keyword is incorrect.
- Insufficient access authority to repository.

## System action

DB Sensor processing ends with a return code of 8.

## User response

Complete the following steps:

1. Ensure that the server XCF group name specified on the ITKBSRVR keyword is correct.
2. Ensure that the IMS Tools KB server is configured and started without any errors. For configuration steps, see the topic "Configuring IMS Tools Knowledge Base" in the *IMS Tools Base Configuration Guide*.

If the problem persists, contact your system administrator to obtain the required level of authorization

---

**BBE1450E**      **DATA DICTIONARY SERVICE  
FAILED. FUNC=function, RC=rc,  
RSN=rsn[, ELEM=data\_element  
xxxx/yyyy]**

## Explanation

One or more errors were detected when the *function* function of the Data Dictionary Service was running. Hexadecimal values *rc* and *rsn* show the return and reason codes of the error, respectively. If the errors are detected in specific data elements, *data\_element* shows the name of the data element, and hexadecimal values *xxxx* and *yyyy* show the return and reason codes of the error, respectively.

## System action

DB Sensor processing ends with a return code of 8.

## User response

Determine if the correct load module library for Policy Services is specified in your JCL. See the *IMS Tools Base Policy Services User's Guide and Reference* to determine the meaning of the return code and reason code. Then, correct the error and rerun the job. If the problem persists, record all the messages that were issued from the conditional reorganization job and contact IBM Software Support.

---

**BBE1451E**      **SENSOR DATA SERVICE FAILED.  
FUNC=function, RC=rc, RSN=rsn[,  
ELEM=data\_element xxxx/yyyy]**

## Explanation

One or more errors were detected when the *function* function of the sensor data service was running. Hexadecimal values *rc* and *rsn* show the return and

reason codes of the error, respectively. If the errors are detected in specific data elements, *data\_element* shows the name of the data element, and hexadecimal values *xxxx* and *yyyy* show the return and reason codes of the error, respectively.

If this message contains FUNC=INIT, RC=4, and RSN=X'52', the message indicates that the Sensor Data repository is not initialized.

### System action

DB Sensor processing ends with a return code of 8.

### User response

Determine if the correct load module library for Policy Services is specified in your JCL. See the *IMS Tools Base Policy Services User's Guide and Reference* to determine the meaning of the return code and reason code. Then, correct the error and rerun the job.

When FUNC=INIT, RC=4, and RSN=X'52', follow the instructions in the topic "Initializing the Sensor Data and Input repositories" in the *IMS Tools Base Configuration Guide* and initialize the Sensor Data repository. Then, rerun the job.

If the problem persists, record all the messages issued from the conditional reorganization job and contact IBM Software Support.

---

**BBE1452E**      **DB SENSOR DID NOT STORE  
SENSOR DATA FOR DATABASE  
*dbdname* [,PARTITION *partname* ]**

### Explanation

DB Sensor did not store the sensor data for the indicated database and the partition.

### System action

DB Sensor processing ends with a return code of 8.

### User response

The probable cause of this error is that one of the following events occurred:

- The IMS Tools KB server ended while DB Sensor was running.
- Not enough space is available to store the sensor data in the Sensor Data repository.

Ensure that the IMS Tools KB server is operating correctly and that the Sensor Data repository has enough space to store the sensor data. Also, check the BBE messages that were issued before this message.

---

**BBE1453W**      **DB SENSOR COULD NOT COLLECT  
DATA FOR *data\_element* FOR  
DATABASE *dbdname* [, PARTITION  
*partname*].**

### Explanation

DB Sensor failed to collect information for the indicated data element for the indicated database or the HALDB partition.

### System action

DB Sensor continues processing without storing the data element in the IMS Tools KB Sensor Data repository. When the process is complete, DB Sensor ends with return code 4.

### User response

See the description for message BBE1332I. If message BBE1332I is not issued, contact IBM Software Support.

---

**BBE2900I**      ***resource\_name* IN  
RECONID=*recon\_id* HAS BEEN  
REORGANIZED, AND NO  
EXCEPTIONS WERE DETECTED  
AFTER THE REORG.**

### Explanation

The Smart Reorg utility reorganized the database or the partition *resource\_name*. No exception was detected after the reorganization. *recon\_id* shows the eight byte RECON ID of the RECON environment to which the database resource belongs.

### System action

The Smart Reorg job continues its processing.

### User response

No user action is needed because all the detected exceptions were removed by the database reorganization.

---

**BBE2901I**      ***resource\_name* IN  
RECONID=*recon\_id* HAS BEEN  
REORGANIZED, BUT SOME  
WARNING EXCEPTIONS REMAIN.**

### Explanation

The Smart Reorg utility reorganized the database or the partition *resource\_name*. Some warning-level exceptions remain after the reorganization. *recon\_id*



shows the 8 byte RECON ID of the RECON environment to which the database resource belongs.

### System action

The Smart Reorg job continues its processing.

### User response

Check the exceptions that remain after the reorganization. If you identify that any of those exceptions need to be addressed, follow the instructions in “Resolving database exceptions” on page 207.

---

**BBE2902I**      *resource\_name* IN  
RECONID=*recon\_id* HAS  
WARNING EXCEPTIONS IN THE  
REORG DOMAIN.

### Explanation

Policy Services detected exceptions in the full-function database resource *resource\_name*. All the exceptions were warning-level exceptions. *recon\_id* shows the 8 byte RECON ID of the RECON environment to which the database resource belongs.

### System action

Policy Services continues its processing.

### User response

Check the exceptions that were reported by Policy Services and identify whether any of those exceptions need to be addressed. If you have identified the need for further analysis, follow the following guidelines:

- The guideline in the topic "Analyzing and tuning IMS full-function databases" of the *IMS Solution Packs: IMS Database Space Tuning Guide* if you are using Autonomics Director.
- The instructions in “Resolving database exceptions” on page 207 if you are using the Smart Reorg utility.

---

**BBE2903I**      *resource\_name* IN  
RECONID=*recon\_id* HAS BEEN  
REORGANIZED, BUT IS STILL IN A  
"REORG NEEDED" STATE.

### Explanation

The Smart Reorg utility reorganized the database or the partition *resource\_name*. However, the utility still identifies the database or the partition as in need of reorganization. *recon\_id* shows the 8 byte RECON ID of the RECON environment to which the database resource belongs.

### System action

The Smart Reorg job continues its processing.

### User response

Check the critical-level exceptions that remain after reorganization and any accompanying exceptions that are in lower severity. Then, follow the instructions in “Resolving database exceptions” on page 207 to remove the critical-level exceptions.

---

**BBE2904I**      *resource\_name* IN  
RECONID=*recon\_id* HAS BEEN  
REORGANIZED, BUT IS STILL IN A  
CRITICAL STATE.

### Explanation

The Smart Reorg utility reorganized the database or the partition *resource\_name*. However, the utility still identifies the database or the partition as in critical state. *recon\_id* shows the 8 byte RECON ID of the RECON environment to which the database resource belongs.

### System action

The Smart Reorg job continues its processing.

### User response

Check the critical-level exceptions that remain after reorganization and any accompanying exceptions that are in lower severity. Then, follow the instructions in “Resolving database exceptions” on page 207 to remove the critical-level exceptions.

---

**BBE2905I**      *resource\_name* IN  
RECONID=*recon\_id* HAS CRITICAL  
EXCEPTIONS IN THE REORG  
DOMAIN. USER ACTION IS  
REQUIRED.

### Explanation

Policy Services detected one or more critical-level exceptions in the database resource *resource\_name* and none of those exceptions will be resolved by just a free space reorganization using unload and reload without definition change. *recon\_id* shows the 8 byte RECON ID of the RECON environment to which the database resource belongs.

### System action

Policy Services continues its processing.

## User response

You should change some parameters for the database definition or database data set space allocation.

Check the critical-level exceptions that were reported and any accompanying exceptions that are in lower severity. Then, follow the following guidelines to remove the critical-level exceptions:

- The guideline in topic "Analyzing and tuning IMS full-function databases" of the *IMS Solution Packs: IMS Database Space Tuning Guide* if you are using Autonomics Director.
- The instructions in ["Resolving database exceptions" on page 207](#) if you are using the Smart Reorg utility.

---

**BBE2906I**      **THE REORGANIZATION OF *resource\_name* IN RECONID=*recon\_id* WAS ATTEMPTED AND FAILED.**

## Explanation

The Smart Reorg utility detected one or more critical-level exceptions in the database or the partition *resource\_name*. The utility attempted reorganization, but it failed. *recon\_id* shows the 8 byte RECON ID of the RECON environment to which the database resource belongs.

## System action

The Smart Reorg job continues its processing.

## User response

Because the reorganization failed and the detected exceptions remain, you must reorganize the database or the partition, change the database definition, or do space allocation change based on the exceptions that remain.

Check the critical-level exceptions that were reported by any accompanying exceptions that are in lower severity. Then, follow the instructions in ["Resolving database exceptions" on page 207](#) to remove the exceptions.

---

**BBE2907I**      ***resource\_name* IN RECONID=*recon\_id* HAS BEEN REORGANIZED, BUT IS STILL IN A SEVERE STATE.**

## Explanation

The Smart Reorg utility detected one or more critical-level exceptions in the database or the partition *resource\_name*. The utility reorganized the database or the partition, but one or more severe-level exceptions

remain. *recon\_id* shows the 8 byte RECON ID of the RECON environment to which the database resource belongs.

## System action

The Smart Reorg job continues its processing.

## User response

Check the severe-level exceptions that remain after reorganization and any accompanying warning-level exceptions. If you identify that any of those exceptions need to be addressed, follow the instructions in ["Resolving database exceptions" on page 207](#).

---

**BBE2908I**      ***resource\_name* IN RECONID=*recon\_id* HAS SEVERE EXCEPTIONS IN THE REORG DOMAIN.**

## Explanation

Policy Services detected one or more severe-level exceptions in the database resource *resource\_name*. However, no critical level exception was reported. *recon\_id* shows the 8 byte RECON ID of the RECON environment to which the database resource belongs.

## System action

Policy Services continues its processing.

## User response

Check the severe-level exceptions that were detected by Policy Services and any accompanying warning-level exceptions and identify whether any of those exceptions need to be addressed. If you have identified the need for further analysis, follow the following guidelines:

- The guideline in topic "Analyzing and tuning IMS full-function databases" of the *IMS Solution Packs: IMS Database Space Tuning Guide* if you are using Autonomics Director.
- The instructions in ["Resolving database exceptions" on page 207](#) if you are using the Smart Reorg utility.

---

**BBE2909I**      ***resource\_name* IN RECONID=*recon\_id* HAS BEEN REORGANIZED, BUT ITS STATUS IS UNAVAILABLE.**

## Explanation

The Smart Reorg utility reorganized the database or the partition *resource\_name*. However, the statistics of the database after the reorganization is not available

for some reason. Report completion code (RCC) 20 or 24 is assigned to the Diagnosis report, depending on the reason why the collection of database statistics failed.

- RCC 20 indicates that the CRSS succeeded in storing sensor data after the reorganization, but the evaluation of the sensor data failed.
- RCC 24 indicates that the CRSS failed in storing sensor data after the reorganization.

For details about these RCCs, see [“Finding Diagnosis reports by using report completion codes”](#) on page 208.

*recon\_id* shows the 8 byte RECON ID of the RECON environment to which the database resource belongs.

### System action

The Smart Reorg job continues its processing.

### User response

Check the RCC that is assigned to the Diagnosis report and take either of the actions:

- When RCC is 20, rerun the Smart Reorg job by specifying `CONDREORG=YES,DIAGONLY` in the (REORG) block and `DIAGDATAFROM=REPOSITORY` in the (CONDREORG) block. Then, check if any exception remains by looking at the Diagnosis report generated by the job. If an exception is reported, follow the instructions in [“Resolving database exceptions”](#) on page 207.
- When RCC is 24, rerun the Smart Reorg job by specifying `CONDREORG=YES,DIAGONLY` in the (REORG) block and `DIAGDATAFROM=DBSENSOR` in the (CONDREORG) block. Then, check if any exception remains by looking at the Diagnosis report generated by the job. If an exception is reported, follow the instructions in [“Resolving database exceptions”](#) on page 207.

---

**BBE2910I**      **ACTION "REORG" IS  
RECOMMENDED FOR  
resource\_name IN  
RECONID=recon\_id.**

### Explanation

Policy Services detected one or more critical-level exceptions in the database resource *resource\_name* and recommends free space reorganization of the resource. *recon\_id* shows the 8 byte RECON ID of the RECON environment to which the database resource belongs.

### System action

Policy Services continues its processing.

### User response

If you are using Autonomics Director, follow the guideline in topic "Analyzing and tuning IMS full-function databases" of the *IMS Solution Packs: IMS Database Space Tuning Guide* to resolve the reported exceptions.

If you are using the Smart Reorg utility, take either of the following actions:

- If the Smart Reorg utility was run in Diagnosis-only mode—that is, the control statement `CONDREORG=YES,DIAGONLY` was specified—this message does not indicate an error. Follow the instructions in [“Resolving database exceptions”](#) on page 207 to determine the appropriate actions to take.
- If the Smart Reorg utility was run in Conditional Reorganization mode, or in Reorganization Diagnosis mode, some error might have occurred in the job. Check the reason why the Smart Reorg utility did not reorganize the database or the HALDB partition by following the instructions in [“Identifying the cause of database exceptions”](#) on page 206, and resolve the error.
  - If you resolve the error that prevented the reorganization without changing the database or the HALDB partition, you can perform conditional reorganization by running the Smart Reorg job by specifying `CONDREORG=YES` in the (REORG) block and `DIAGDATAFROM=REPOSITORY` in the (CONDREORG) block.
  - If you resolve the error that prevented the reorganization, and if the state of the database or the partition was changed significantly after the previous run, you must collect the sensor data again to get the latest statistics of the database to perform conditional reorganization. To do this, run the Smart Reorg job by specifying `CONDREORG=YES` in the (REORG) block and `DIAGDATAFROM=DBSENSOR` in the (CONDREORG) block.

---

**BBE2930I**      *rule\_exception\_message\_text*

### Explanation

If an exception is detected by the evaluation of a rule that is specified in the selected policy, and one or more notification lists are specified for that specific rule, the message text (*rule\_exception\_message\_text*) specified in the rule is sent to all destinations (directory entries) listed in the notification lists. The message is sent by using the Policy Services Notification Manager. For

details of the rule exception message text, see the *IMS Tools Base Policy Services User's Guide and Reference*.

If you are using the Smart Reorg utility, the message is sent only when all of the following conditions are satisfied:

1. Smart Reorg job is running in Conditional Reorganization mode (CONDREORG=YES) or in Reorganization Diagnosis mode (CONDREORG=YES,REORGDIAG)
2. The exception that was detected by the rule remains after the job completes

**Note:** This message is not sent when the Smart Reorg job is running in Diagnosis-only mode (CONDREORG=YES,DIAGONLY) even if condition 2 is satisfied.

### System action

Policy Services continues its processing.

### User response

Check the policy evaluation summary message that is sent separately and follow the User response section for the summary message.

---

**BBE3201E** GETMAIN FAILED. RC=*rc*,  
SIZE=*size*, MOD: *modname*,  
ERROR-ID: *error\_id*

### Explanation

The GETMAIN macro failed with return code *rc*. *size* shows the size of the area that is specified in the macro, *modname* and *error\_id* show the location and cause of the error.

### System action

DB Sensor processing ends with a return code of 16.

### User response

See the *z/OS MVS Assembler Services Reference* to determine the meaning of the return code. If the problem is due to a lack of storage, increase the region size by specifying a larger value for the REGION parameter in the JCL and rerun the job. If the problem is due to other reasons, contact IBM Software Support.

---

**BBE3202E** FREEMAIN FAILED. RC=*rc*, MOD:  
*modname*, ERROR-ID: *error\_id*

### Explanation

The FREEMAIN macro failed with return code *rc*. *modname* and *error\_id* show the location and cause of the error.

### System action

DB Sensor processing ends with a return code of 8.

### User response

This is probably an internal error. Contact IBM Software Support.

---

**BBE3203E** OPEN FAILED. DB=*dbdname*,  
DD=*ddname*, DSORG=*dsorg*,  
RC=*rc*, RSN=*rsn*, MOD=*modname*,  
ERROR-ID=*error\_id*

### Explanation

The DB Sensor function failed to open the database data set *ddname* DD. *rc* is the return code and *rsn* is the reason code from the macro. *modname* and *error\_id* show the location and cause of the error.

### System action

DB Sensor processing ends with a return code of 8.

### User response

See *z/OS DFSMS Macro Instructions for Data Sets* to determine the meaning of the return code and reason code. Then, correct the error and rerun the job. If the error is not in the data set or your system, contact IBM Software Support.

---

**BBE3204E** VSAM *xxxxxxx* FAILED. RC=*rc*,  
RSN=*rsn*, DD: *ddname*, MOD:  
*modname*, ERROR-ID: *error\_id*

### Explanation

The macro for the VSAM data set *ddname* DD failed. *rc* is the return code and *rsn* is the reason code from the macro. *modname* and *error\_id* show the location and cause of the error.

### System action

DB Sensor processing ends with a return code of 8.

### User response

See *z/OS DFSMS Macro Instructions for Data Sets* to determine the meaning of the return code and reason code. Then, correct the error and rerun the job. If the

error is not in the data set or your system, contact IBM Software Support.

---

**BBE3205E**      **LOAD FAILED. SC=*sc*, RSN=*rsn*, DD: *ddname*, MEMBER: *member*, MOD: *modname*, ERROR-ID: *error\_id***

### Explanation

The LOAD macro failed with system completion code *sc* and reason code *rsn*. *member* shows the name of the member that caused the failure. *modname* and *error\_id* show the location and cause of the error.

### System action

DB Sensor processing ends with a return code of 8 or 16.

### User response

See the *z/OS MVS Assembler Services Reference* to determine the meaning of the return code and reason code. Then, correct the error and rerun the job. If the error is not in the data set or your system, contact IBM Software Support.

---

**BBE3206E**      **DYNAMIC ALLOCATION FAILED. RC=*rc*, RSN=*rsn*, DD: *ddname*, MOD: *modname*, ERROR-ID: *error\_id***

### Explanation

A database data set could not be dynamically allocated. This message contains the following information:

- *rc* indicates the return code.
- *rsn* indicates the reason code.
- *ddname* indicates the name of the DD for which the allocation failed.
- *modname* indicates the module name in which the error occurred.
- *error\_id* indicates the cause of the error.

Another BBE3206E message follows this message. The second BBE3206E message indicates the name of the data set that could not be allocated.

### System action

DB Sensor processing ends with return code 8.

### User response

Ensure that the data set information is correctly cataloged to the system catalog. If no problems are found in the catalog, see the topic about interpreting DYNALLOC return codes in the *z/OS MVS Authorized Assembler Services Guide* to determine the meaning of the return code and reason code. Correct the error and rerun the job. If the error is not in the data set or your system, contact IBM Software Support.

---

**BBE3207E**      **OBTAIN FAILED. RC=*rc*, DSCB: *dscbname*, DD: *ddname*, MOD: *modname*, ERROR-ID: *error\_id***

### Explanation

The OBTAIN macro failed to read a DSCB by data set name with return code *rc*. *dscbname* shows the name of the DSCB that was used in the macro, and *ddname* shows the DD name that could not be obtained. *modname* and *error\_id* show the location and cause of the error.

### System action

DB Sensor processing ends with a return code of 8.

### User response

If the return code is 16 (X'10'), contact IBM Software Support. Otherwise, see *z/OS DFSMSdfp Advanced Services* to determine the meaning of the return code. Then, correct the error and rerun the job.

---

**BBE3208E**      **UCBSCAN FAILED. RC=*rc*, RSN=*rsn*, DD: *ddname*, MOD: *modname*, ERROR-ID: *error\_id***

### Explanation

The UCBSCAN service failed for *ddname* DD with return code *rc* and reason code *rsn*. *modname* and *error\_id* show the location and cause of the error.

### System action

DB Sensor processing ends with a return code of 8.

### User response

Contact IBM Software Support.

---

**BBE3209E**      **NAME/TOKEN SERVICE (*pgmname*) FAILED. RC=*rc*, NAME: *nametoken\_name***

## Explanation

The Name/Token callable service failed with return code *rc*. *pgmname* shows the program name of the Name/Token callable service, and *nametoken\_name* shows the name of Name/Token pairs.

## System action

DB Sensor processing ends with a return code of 16.

## User response

Contact IBM Software Support.

---

**BBE3210E**      **UCBINFO FAILED. RC=*rc*, RSN=*rsn*, DD: *ddname*, VOLSER: *volume\_serial*, MOD: *modname*, ERROR-ID: *error\_id***

## Explanation

The UCBINFO service failed with return code *rc* and reason code *rsn*. *ddname* and *volume\_serial* show the names of the DD and the volume for which the UCBINFO macro was issued. *modname* and *error\_id* show the location and cause of the error.

## System action

DB Sensor processing ends with a return code of 8.

## User response

Contact IBM Software Support.

---

**BBE3211E**      **IGWASYS FAILED. RC=*rc*, RSN=*rsn***

## Explanation

The IGWASYS routine failed with return code *rc* and reason code *rsn*.

## System action

DB Sensor processing ends with a return code of 16.

## User response

Contact IBM Software Support.

---

**BBE3212E**      **DFSMS VERSION IS LOWER THAN 1.7**

## Explanation

The current version of DFSMS is earlier than the minimum version required.

## System action

DB Sensor processing ends with a return code of 16.

## User response

Use DFSMS 1.7 or later, and rerun the job.

---

**BBE3213E**      **BLDL FAILED. RC=*rc*, RSN=*rsn*, DD: *ddname*, MEMBER: *member*, MOD: *modname*, ERROR-ID: *error\_id***

## Explanation

The BLDL macro failed with return code *rc* and reason code *rsn*. *member* shows the name of the member that caused the failure. *modname* and *error\_id* show the location and cause of the error.

## System action

DB Sensor processing ends with a return code of 8.

## User response

Check the data set that is specified by the *ddname* DD to see if the member is included in the data set. If the member is included in the data set, identify the cause of the BLDL failure by determining the meaning of the return code and reason code, which are documented in *z/OS DFSMS Macro Instructions for Data Sets*. Then, correct the error and rerun the job. If the error is not in the data set or your system, contact IBM Software Support.

---

**BBE3214E**      **HPIO *function* FUNCTION FAILED FOR *ddname* DD**

## Explanation

An error occurred while processing the *function* function of High Performance I/O driver for *ddname* DD.

## System action

DB Sensor processing ends with a return code of 8 during the SCAN process or issues U3214 during the main process.

## User response

Contact IBM Software Support.

---

**BBE3217E**      **DATA DICTIONARY ACCESS FAILED: FUNC=*function* RC=*rc* RSN=*rsn***

## Explanation

DB Sensor issued the IMS Tools Base Policy Service Data Dictionary API call to obtain the following data element information, but the API did not complete successfully.

- DB\_PCT\_NUM\_FRAGD\_FSE
- DB\_AVG\_NUM\_FRAGD\_FSE
- DB\_PCT\_NUM\_NOREUSE\_FSE
- DB\_FLAG\_SENSOR\_HOME

## System action

DB Sensor processing ends with return code 8.

## User response

Contact IBM Software Support.

---

**BBE3250E**      **LOAD FAILED FOR *modname* MODULE. CODE=*nnn*, RSN=*rsn***

## Explanation

The DB Sensor function failed to load the *modname* module. The hexadecimal value *nnn* shows the system completion code and the hexadecimal value *rsn* shows the associated reason code that are returned from the LOAD macro.

## System action

DB Sensor processing ends with a return code of 8.

## HPSC messages

Common IMS Database Reorganization Expert messages begin with HPSC.

---

**HPSC3601E**      **PARAMETER ERROR DETECTED ON PARM: *parm\_string***

## Explanation

An incorrect parameter is detected. The incorrect parameter string is listed as *parm\_string*.

## System action

IMS Database Reorganization Expert issues user abend 3601.

## User response

Correct the parameter error, and rerun the job.

## User response

See *MVS System Codes* to determine the meaning of the system completion code. Then, correct the error and rerun the job. If the problem persists, contact IBM Software Support.

---

**BBE3251E**      **GETMAIN FAILED WITH RC=*rc* (SIZE=*size*) IN *modname* MODULE, ERROR-ID: *error\_id***

## Explanation

The DB Sensor function failed to obtain storage. *size* shows the size of the storage that could not be obtained. The hexadecimal value *rc* shows the return code that is returned from the GETMAIN macro. *modname* shows the name of the failed module, and *error\_id* shows the error ID that is associated with the module.

## System action

DB Sensor processing ends with a return code of 8.

## User response

See the *MVS Programming: Assembler Services Reference* to determine the meaning of the return code. Then, correct the error and rerun the job. If the problem persists, contact IBM Software Support.

## Problem determination

Check the parameter specification listed as *parm\_string*.

---

**HPSC3615E**      **LOAD FAILED FOR MODULE: *mod\_name* DDNAME: *ddname***

## Explanation

After a LOAD macro had been issued to load the module *mod\_name* from the library specified by the *ddname* DD statement, the register 15 contained a nonzero return code.

## System action

IMS Database Reorganization Expert issues user abend 3615.



## User response

Correct the error and rerun the job. If the problem remains, save the entire run listing (including the dump and JCL stream) and contact IBM Software Support.

## Problem determination

Make sure that the DD statement associated with *ddname* indicates the correct data set.

---

**HPSC3701W**      **DECODE PROCESSING FOR DBD'S  
IN LIBRARY *ddname* ENDED WITH  
WARNING**

## Explanation

The LMU service call to decode the DBD of the primary database and its indexes in the DBD library whose DDNAME is *ddname* ended with a decimal return code of 4. At least one warning message from LMU is printed in the Decoded DBD report. For the meaning of the return code and the meaning of the warning messages, see the *IMS Library Integrity Utilities User's Guide*.

If this job runs in an IMS-managed ACBs environment, *ddname* shows IMSD0000.

## System action

IMS Database Reorganization Expert continues processing.

## User response

Refer to the Decoded DBD report to check the meaning of each warning message issued by LMU.

---

**HPSC3702E**      **DECODE PROCESSING FOR DBD'S  
IN LIBRARY *ddname* FAILED WITH  
RC=*ccc***

## Explanation

The LMU service call to decode the DBD of the primary database and its indexes in the DBD library whose DDNAME is *ddname* ended with a decimal return code of *ccc*. At least one message from LMU is printed in the Decoded DBD report. For the meaning of the return code and the meaning of the error messages, see the *IMS Library Integrity Utilities User's Guide*.

If this job runs in an IMS-managed ACBs environment, *ddname* shows IMSD0000.

## System action

IMS Database Reorganization Expert issues user abend 3702.

## User response

Refer to the Decoded DBD report to check the meaning of each warning message issued by LMU.

---

**HPSC3703W**      **LMU IS NOT INSTALLED OR NOT IN  
REQUIRED LEVEL (*level*)**

## Explanation

LMU is not found in any library concatenated to the STEPLIB DD statement, or the release level or the maintenance level of LMU is not high enough to support the requested LMU service. The value *level* indicates the level of LMU service. For details, see ["Software prerequisites"](#) on page 39.

## System action

IMS Database Reorganization Expert continues processing without performing the requested LMU service.

## User response

If you want to use the requested LMU service, install LMU and apply the required maintenance. Otherwise, remove the control statement that requests the LMU service.

---

**HPSC3704I**      ***opt* OPTION IGNORED**

## Explanation

The option *opt* requested by a control statement or by an installation default option is ignored. A preceding message or messages indicate why. The default option value of the system is used.

*opt* is one of the following:

- DECODEDBD REPORT
- DECODESXD REPORT

## System action

IMS Database Reorganization Expert continues processing by using the default option value of the system.

## User response

Refer to the preceding messages.



---

**HPSC3710E DD STATEMENT FOR DDNAME  
xxxxxxx IS NOT CODED****Explanation**

The DD statement for the indicated DD name xxxxxxxx is not coded in the JCL stream.

**System action**

IMS Database Reorganization Expert issues user abend 3710.

**User response**

Specify the missing DD statement.

---

**HPSC3711E DEVTYPE MACRO FAILED ON  
DDNAME: xxxxxxxx (RC=rc)****Explanation**

An error occurred when the DEVTYPE macro was used to get information about the device associated with the DD name xxxxxxxx. The value *rc* shows the return code from the DEVTYPE macro.

**System action**

IMS Database Reorganization Expert issues user abend 3711.

**User response**

Check whether the DD statement for the indicated DD name points to the correct data set. Correct the error and rerun the job.

---

**HPSC3712E DUMMY SPECIFIED FOR xxxxxxxx  
DD STATEMENT****Explanation**

DUMMY was specified for the DD name xxxxxxxx. DUMMY is not allowed for this DD statement.

**System action**

IMS Database Reorganization Expert issues user abend 3712.

**User response**

Correct the DD statement, and rerun the job.

---

**HPSC3713E OPEN FAILED FOR DDNAME:  
ddname****Explanation**

An attempt to open the data set identified by *ddname* failed.

**System action**

IMS Database Reorganization Expert issues user abend 3713.

**User response**

Check the error, and rerun the job.

---

**HPSC3714E GETMAIN ERROR (RC= xx) IN  
MODULE aaaaaaaaa****Explanation**

A storage area is requested in the module *aaaaaaaa* by use of the GETMAIN macro, but an error return code of *xx* is returned.

**System action**

IMS Database Reorganization Expert issues user abend 3714.

**User response**

Identify the cause of the GETMAIN error by referring to *z/OS MVS Assembler Services Reference*.

---

**HPSC3715E CLOSE FAILED FOR DDNAME:  
ddname****Explanation**

An attempt to CLOSE the data set identified by *ddname* failed.

**System action**

IMS Database Reorganization Expert issues user abend 3715.

**User response**

Check the error, and rerun the job.

---

**HPSC3716E BLDL MACRO FAILED FOR  
MEMBER mbrname IN LIBRARY  
ddname (RC=rc, RSN=rsn)****Explanation**

The BLDL macro failed for member *mbrname* in the library that has the DD name of *ddname*. The return code from the macro call was *rc* and the reason code was *rsn*.

## System action

IMS Database Reorganization Expert issues user abend 3716.

## User response

This error is likely an internal system error. Contact IBM Software Support.

---

**HPSC3717I NO S-INDEX DBD DECODED  
BECAUSE NONE FOUND FOR DBD  
dbdname IN LIBRARY ddname**

## Explanation

DECODESX=YES is specified for database *dbdname* in the DBD library *ddname*, but no secondary index is defined for the database.

## System action

DECODESX=YES is ignored for database *dbdname* in the DBD library *ddname*. IMS Database Reorganization Expert continues processing.

## User response

None. This message is informational.

---

**HPSC3718E AN INTERNAL ERROR OCCURRED**

## Explanation

An internal error occurred in an LMU service call. This message is accompanied by a message issued from LMU. For the meaning of the error messages, see the *IMS Library Integrity Utilities User's Guide*.

## System action

IMS Database Reorganization Expert issues user abend 3718.

## User response

Check the meaning of each error message.

---

**HPSC3719I INSTALLATION DEFAULT OPTIONS  
TABLE HPSCOPI (LV.nn) IS  
FOUND**

## Explanation

The Installation Default Options Table (HPSCOPI) is found. HPSCOPI was generated with the HPSCOPI macro of level *nn*. The default values in this table

override the values in the System Default Option Table (HPSCOPTS).

## System action

IMS Database Reorganization Expert continues processing.

## User response

None. This message is informational.

---

**HPSC3720I DEFAULT OPTION TABLES REPORT  
IS NOT PRINTED (RSN=nn)**

## Explanation

The Default Option Tables report is not printed because of the reason shown by the reason code *nn*. The reason code *nn* is one of the following values:

### RSN

#### Description

- 01** The RDJFCB macro failed
- 02** The BLDL macro failed
- 03** The LOAD macro failed
- 04** The loaded module is in an unexpected format

## System action

IMS Database Reorganization Expert continues processing.

## User response

If the reason code is 04, correct the error, and rerun the job. Otherwise, this error is likely an internal system error. Contact IBM Software Support.

---

**HPSC3721E GEX\$CATQ API FAILED RC=rc,  
RSN=rsn, MOD=module, DBD=dbd**

## Explanation

Received an error from the GEX\$CATQ API. The return code from the macro call was *rc* and the reason code was *rsn*. For the reason of the error, see the preceding messages with the GEX prefix that were issued by GEX\$CAQ API.

## System action

The Smart Reorg utility ends with a return code of 8. Other utilities issue user abend 3721.

## User response

Locate preceding error messages and identify the cause of the error.

---

**HPSC3722E** RDJFCB MACRO FAILED ON  
DDNAME: *ddname* (RC=*rc*)

## Explanation

The RDJFCB MACRO failed for DD name *ddname*. The return code from the macro call was *rc*.

## System action

IMS Database Reorganization Expert issues user abend 3722.

## User response

This error is likely an internal system error. Contact IBM Software Support.

---

**HPSC3801I** NOTIFICATION HAS BEEN SENT  
TO AD SERVER

## Explanation

A system notification was sent to Autonomics Director.

## System action

Processing continues.

## User response

None. This message is informational.

---

**HPSC3802I** \*AD API\* FUNC=*function*,  
*parameters...*

## Explanation

This message is issued when both ADXCFGRP=*grpname* and DEBUG=E are specified in the (REORG) block. The parameters that are passed to the Autonomics Director System Notification Service are shown in the message.

## System action

Processing continues.

## User response

None. This message is informational.

---

**HPSC3804W** FAILED TO SEND NOTIFICATION  
TO AD. FUNC=*function*, RC=*rc*,  
RSN=*rsn*

## Explanation

The utility failed to send the system notification to Autonomics Director.

## System action

Processing continues.

## User response

Ensure that the Autonomics Director server that is specified on the ADXCFGRP control statement is started correctly. If DEBUG=E is specified in the (REORG) block of the HPSIN data set, the parameters that were passed to the Autonomics Director System Notification Service are printed in the HPSC3802I message.

---

**HPSC3807W** NOTIFICATION TO AD WAS  
CANCELED. REASON: *reason*

## Explanation

The utility did not send system notification to Autonomics Director because it encountered one of the following conditions:

### DB SOLUTION PACK NOT INSTALLED

A module of IMS Database Solution Pack or IMS Database Utility Solution could not be loaded.

### IAVNTFY0 LOAD FAILURE

The IAVNTFY0 module could not be loaded from the SHKTLOAD library.

### RECON1 DD NOT FOUND

RECON1 DD is not allocated.

## System action

Processing continues without sending a system notification to Autonomics Director.

## User response

Complete one of the following tasks depending on the reason shown in the message:

### DB SOLUTION PACK NOT INSTALLED

Ensure that the IMS Database Solution Pack library or the IMS Database Utility Solution library is specified in the STEPLIB concatenations correctly.

### IAVNTFY0 LOAD FAILURE

Ensure that the SHKTLOAD library of IBM IMS Tools Base is specified in the STEPLIB concatenations correctly.

### RECON1 DD NOT FOUND

Ensure that DBRC=Y is specified.

## HPSG messages

Messages that are issued by the Smart Reorg utility begin with HPSG.

---

**HPSG0001I REORGANIZATION STARTS FOR  
DATABASE xxxxxxxx**

### Explanation

The basic initialization of the Smart Reorg utility has completed successfully, and the rest of the initialization processing and the succeeding reorganization processing are being started. When the Smart Reorg utility is called from the Conditional Reorganization Support Service (CRSS), this message indicates that the target database needs to be reorganized.

### System action

The Smart Reorg utility continues processing.

### User response

None. This message is informational.

---

**HPSG0002E xxxxxx TASK ENDED ABNORMALLY  
(CC= cccc)**

### Explanation

The subtask indicated by string xxxxxx ended abnormally with a completion code of cccc due to an error in the task. The subtask indicated by xxxxxx is:

**xxxx**

#### Subtask

#### UNLOAD

Unload task

#### RELOAD

Reload task

#### IDXBLD

Index Builder task

#### IMGCPY

Image Copy task

#### PRXRES

Prefix Resolution task

#### IMSRGN

IMS Region Task

### System action

Message HPSG0011E is issued, and the Smart Reorg utility ends with a return code of 16.

### User response

Refer to the accompanying error messages that are issued from the abnormally ended task.

---

**HPSG0003E MAIN TASK ENCOUNTERED AN  
ERROR (COMPLETION CODE=*code*  
[, REASON CODE=*yyyyyyyy*])**

### Explanation

An error occurred in the main task. The reason of the error is indicated by the hexadecimal completion code *code* and, optionally, the hexadecimal reason code *yyyyyyyy*.

### System action

The Smart Reorg utility ends with a return code of 16.

### User response

For a system abend, refer to *MVS System Codes* and take appropriate action. For a user abend, refer to the messages that starts with HPSG followed by the same number as the completion code *code* and its explanation.

---

**HPSG0004E UNSUPPORTED LEVEL OF IMS IS  
BEING USED: *nnn***

### Explanation

You are running the IMS Database Reorganization Expert job on an IMS batch region controller (DFSRR00) that is not supported by IMS Database Reorganization Expert. *nnn* indicates the IMS version, release, and modification level.

### System action

The Smart Reorg utility ends with a return code of 8.

### User response

You must run the job on a version of IMS that is supported by IMS Database Reorganization Expert.

---

**HPSG0005E PARAMETER ERROR DETECTED  
ON PARM: *parm\_string***

### Explanation

An incorrect parameter is detected. The incorrect parameter string is listed as *parm\_string*.

## System action

The Smart Reorg utility ends with a return code of 8.

## User response

Correct the parameter error, and rerun the job.

## Problem determination

Check the parameter specification listed as *parm\_string*.

---

**HPSG0006E DD STATEMENT IS SPECIFIED ON THE JCL: *ddname***

## Explanation

The DD statement for *ddname* is specified in the JCL stream. The *ddname* is reserved for system use.

## System action

The Smart Reorg utility ends with a return code of 8.

## User response

Remove the DD statement.

---

**HPSG0007E DBRC=N IS NOT ALLOWED**

## Explanation

You must not specify DBRC=N in the EXEC parameter because your IMS system has been generated as DBRC=FORCE.

## System action

The Smart Reorg utility ends with a return code of 8.

## User response

Remove the subparameter DBRC=N from the EXEC parameter string.

---

**HPSG0008E xxxxxx TASK FORCED TO END DUE TO ERROR IN ANOTHER TASK (CC=*ccc*)**

## Explanation

The task indicated by string *xxxxxx* was detached by a DETACH macro because of an error in another task. The subtask indicated by *xxxxxx* is:

*xxxx*

**Subtask**

**UNLOAD**

Unload task

**RELOAD**

Reload task

**IDXBLD**

Index Builder task

**IMGCPY**

Image Copy task

**PRXRES**

Prefix Resolution task

**IMSRGN**

IMS Region task

The code *ccc* indicates the completion code that the caller of the DETACH macro received. For details of possible completion codes, see the explanation of DETACH macro in the *z/OS MVS Assembler Services Reference*.

## System action

Message HPSG0011E is issued, and the Smart Reorg utility ends with a return code of 16.

## User response

Check the task that originated the error. Correct the error and rerun the job.

---

**HPSG0009E xxxxxx TASK ENDED ABNORMALLY WHILE IT IS BEING DETACHED (CC=*ccc*)**

## Explanation

The task indicated by string *xxxxxx* was detached by a DETACH macro after the normal or abnormal end of the task, but the caller of the DETACH macro received an error completion code *ccc*. For details of possible completion codes, see the explanation of DETACH macro in *z/OS MVS Assembler Services Reference*.

## System action

Message HPSG0011E is issued, and the Smart Reorg utility ends with a return code of 16.

## User response

This error is likely an internal system error. Contact IBM Software Support.

---

**HPSG0010I *process\_option* ENDED FOR DATABASE *dbname* (RC=00)**

## Explanation

The Smart Reorg utility job for database *dbname* ended. *process\_option* indicates following processing option of Smart Reorg:

## REORGANIZATION

The Smart Reorg process without the conditional reorganization feature (CONDREORG=NO)

## CONDREORG FUNC

The Smart Reorg process with the conditional reorganization feature (CONDREORG=YES)

## REORGDIAG FUNC

The Smart Reorg process in Reorganization Diagnosis mode (CONDREORG=YES,REORGDIAG)

## DIAGONLY FUNC

The Smart Reorg process in Diagnosis-only mode (CONDREORG=YES,DIAGONLY)

## System action

The Smart Reorg utility ends.

## User response

None. This message is informational.

---

**HPSG0010W** *process\_option* ENDED FOR  
DATABASE *dbdname* (RC=04,  
RSN=xxxxxxx)

## Explanation

The Smart Reorg utility job for database *dbdname* ended. *process\_option* indicates following processing option of Smart Reorg:

### REORGANIZATION

The Smart Reorg process without the conditional reorganization feature (CONDREORG=NO)

### CONDREORG FUNC

The Smart Reorg process with the conditional reorganization feature (CONDREORG=YES)

### REORGDIAG FUNC

The Smart Reorg process in Reorganization Diagnosis mode (CONDREORG=YES,REORGDIAG)

### DIAGONLY FUNC

The Smart Reorg process in Diagnosis-only mode (CONDREORG=YES,DIAGONLY)

The decimal return code, indicated by RC, has the following meaning:

#### Return code

##### Meaning

**00**

The job ended normally.

**04**

A warning message or messages were issued.

If the return code is 04, a hexadecimal reason code xxxxxxxx for the warnings is shown in the message. The reason code has the following meaning:

#### Reason code

##### Meaning

(xxxxxxx)

**80800004**

One or more warning messages were issued in a subtask or subtasks.

**80800006**

The return code 4 is received from LMU service call.

**40100005**

The automated name swapping has not been performed because NAMESWAP=NO was specified. You need to do manual post processing. For details, see [“Post-reorganization processing”](#) on page 212. Before the manual post processing, however, you need to verify whether the result of the reorganization is acceptable because at least one warning message was issued.

**40100006**

ILDS building has not been done because ILDSBLD=NO was specified. The warning message HPSG0374W precedes this message. Refer to the explanation and the programmer response for HPSG0374W.

**40100007**

Deletion of old data sets is not completed because of an error.

**40100011**

The automated /STA command processing failed and manual processing is required. See message HPSG2104W.

**40100012**

PREFIXRES=YES is ignored because the external logical relationships are defined in the non-HALDB. Run IMS Prefix Resolution and Update utilities after the Smart Reorg utility job-step

**40100013**

ERRC04 is specified for the ITKBSRVR control statement and one or more errors occurred in IMS Tools KB Output repository processing.

**40100014**

One or more errors occurred in the Integrity Checker RDE creation. See message FABLxxxxx issued by Integrity Checker.

**40100015**

One or more errors occurred in the Conditional Reorganization Support Service (CRSS).

**40100017**

One or more errors occurred while sending a system notification to Autonomics Director.

**40100018**

The automated /STA command is not issued. See message HPSG0456W.

## System action

The Smart Reorg utility ends.

## User response

If the return code is 04, refer to the accompanying warning messages and follow the required programmer responses for those messages.

---

**HPSG0011E** *process\_option* ABORTED FOR DATABASE *dbname* (RC=*rc*, RSN=*xxxxxxxx*)

## Explanation

The Smart Reorg utility job for database *dbname* ended. *process\_option* indicates following processing option of Smart Reorg:

### REORGANIZATION

The Smart Reorg process without the conditional reorganization feature (CONDREORG=NO)

### CONDREORG FUNC

The Smart Reorg process with the conditional reorganization feature (CONDREORG=YES)

### REORGDIAG FUNC

The Smart Reorg process in Reorganization Diagnosis mode (CONDREORG=YES,REORGDIAG)

### DIAGONLY FUNC

The Smart Reorg process in Diagnosis-only mode (CONDREORG=YES,DIAGONLY)

The decimal return code *rc* has the following meaning:

### Return code

#### Meaning

#### 08

One or more errors were detected.

#### 16

A severe error occurred.

A hexadecimal reason code *xxxxxxxx* for the error is shown in the message. The reason code has the following meaning:

### Reason code

#### Meaning

(*xxxxxxxx*)

#### 80800001

An error occurred while the task manager were being initialized.

#### 80800002

An error occurred while the reorganization tasks were running.

#### 80800003

An error occurred while the task manager were being terminated.

#### 80800005

An error occurred while the reorganization tasks were running.

#### 80800007

An error occurred during the report processing of the reorganization tasks.

#### 80800008

An error occurred during prefix resolution processing.

#### 80800009

An error occurred during the Type-B Image Copy processing.

#### 80400001

An error occurred while the control statements were analyzed.

#### 80200001

An error occurred while the report manager was being initialized.

#### 80100001

An error occurred while the pipes were being allocated.

#### 80100002

An error occurred while the pipes were being deallocated.

#### 40800001

An error was found while the original DBD was being analyzed.

#### 40400001

An error was found while the new DBD was being analyzed.

#### 40400002

The status of the database was not satisfied for starting parallel reorganization.

#### 40400003

An error was found while the input or output data sets for the database and indexes were being allocated.

#### 40400004

An error was found while the Data Set Information report was being written.

#### 40400005

An error was found while the secondary indexes were being analyzed.

#### 40200001

An error was found while the runtime options were being checked.

#### 40200002

An error was found while the output data sets for the HALDB were being allocated.

#### 40200003

An error occurred while processing the PSINDEX in PSINDEXBLD update mode.

**40200004**

An error occurred while copying the PSINDEX in PSINDEXBLD update mode.

**40100001**

Not all conditions for name swapping were satisfied due to one or more warning messages in a subtask or subtasks.

**40100002**

The status of the databases was not satisfied for name swapping.

**40100003**

An error was found during the name swapping. The automated backout processing was not done.

**40100004**

An error was found during DBRC notification processing.

**40100008**

An error was found during the name swapping. Automated backout processing was completed.

**40100009**

An error was found during the name swapping. Automated backout processing failed.

**40100010**

An error was found during the /START DB command processing.

**40100014**

One or more errors occurred in the Integrity Checker RDE creation. See message FABLxxxxE issued by Integrity Checker.

**40100015**

One or more errors occurred in the Conditional Reorganization Support Service (CRSS).

**40010001**

An error occurred while Reorganization Manager was being initialized.

**System action**

The Smart Reorg utility job is stops.

**User response**

Refer to the accompanying error messages and follow the required user responses for those messages. After the problem is resolved, rerun the Smart Reorg utility job.

---

**HPSG0012E DBRC MUST BE ACTIVE**

**Explanation**

If the database to be reorganized is a HALDB, you need to make DBRC active.

**System action**

The Smart Reorg utility ends with a return code of 8.

**User response**

In the EXEC parameter, set the value of the DBRC subparameter to DBRC=Y; then rerun the job.

---

**HPSG0013I xxxxxx TASK FORCED TO END DUE TO ERROR IN ANOTHER TASK**

**Explanation**

The subtask indicated by the keyword xxxxxx was forced to terminate because of an error in another task. Keyword xxxxxx is one of the following values:

**Keyword**

**The task indicated by the keyword**

**IMGCPY**

Image Copy task

**PFXRES**

Prefix Resolution task

**IMSRGN**

IMS Region task

**System action**

The task identified by keyword xxxxxx is forced to end, and the Smart Reorg utility ends with a non-zero return code.

**User response**

Check the task that caused the error. Correct the error and rerun the job.

---

**HPSG0014I xxxxxx TASK FORCED TO END DUE TO ERROR IN ANOTHER TASK**

**Explanation**

The subtask indicated by the keyword xxxxxx was detached by the DETACH macro because of an error in another task. Keyword xxxxxx is one of the following:

**Keyword**

**The task indicated by the keyword**

**UNLOAD**

Unload task

**RELOAD**

Reload task

**IDXBLD**

Index Builder task

**IMGCPY**

Image Copy task



## PFXRES

Prefix Resolution task

## IMSRGN

IMS Region Task

### System action

The task identified by the keyword xxxxxx was forced to terminate. Smart Reorg utility ends with a non-zero return code.

### User response

Check the task that originated the error. Correct the error and rerun the job.

---

**HPSG0015W**      **IMAGE COPY PROCESSING  
FAILED, BUT REORG PROCESSING  
CONTINUES**

### Explanation

An error occurred in the type-A image copy processing, however, the reorganization processing in other tasks continues.

### System action

The Smart Reorg utility continues processing until other tasks are completed.

### User response

See the prior message FABJ0999E that is issued by Image Copy.

---

**HPSG0016A**      **REORG ENDED WITH AN IMAGE  
COPY ERROR FOR DATABASE  
*dbdname* (RC=12)**

### Explanation

All subtasks other than the Image Copy task ended normally or with warnings. Message HPSG0312E or HPSG0332W with the warning "ERROR IN IMGCPY TASK" precedes this message. Database *dbdname* has been reloaded.

If INDEXBLD=YES or PSINDEXBLD=YES was specified, the secondary indexes are built. If PREFIXRES=YES was specified, the segment prefixes are updated.

### System action

The Smart Reorg utility ends with a return code of 12.

## User response

Discard all image copy data sets created in the Smart Reorg utility job. Check the cause of the Image Copy error. If the problem in the Image Copy task can be solved, check the return code and reason code of other tasks. If all other tasks ended normally or the warnings are not so important that you can ignore them, follow the procedure of manual post-reorganization processing, which is described in "Post-reorganization processing" on page 212. You can use the IDCAMS command stream printed in the IDCAMS COMMAND STREAM FOR NAME SWAPPING report, but you must issue NOTIFY.REORG commands for the reorganized database and indexes and you must take image copies by running IMS HP Image Copy.

If the problem in the Image Copy task cannot be fixed, collect the output reports of the Smart Reorg utility job and contact IBM Software Support.

If any error message or warning message of the IMS HP Pointer Checker, which is prefixed with FABP is issued, there is a possibility that there are pointer errors in the reloaded shadow database or rebuilt indexes. In this case, collect the output report of the Smart Reorg utility job and contact IBM Software Support.

---

**HPSG0017E**      **INFORMATION ABOUT TWO OR  
MORE LOGICAL GROUPS IS  
FOUND IN THE DFSURCDS DATA  
SET**

### Explanation

The data set that is specified by the DFSURCDS DD contains information about multiple logical groups. The Pre-reorganization utility can process only one logical group.

### System action

The Pre-reorganization utility ends with a return code of 8.

### User response

Re-create the DFSURCDS data set by running the IMS Database Prereorganization utility (DFSURPRO), and rerun the Pre-reorganization utility job.

---

**HPSG0018I**      **HPSGCTL DD IS FOUND. THE  
SMART REORG UTILITY WILL NOT  
PERFORM POST PROCESSING**

### Explanation

The Smart Reorg utility found an HPSGCTL DD statement in the JCL stream. Therefore, the utility

does not perform post-processing. Post-processing must be performed by running the Post-reorganization utility.

### System action

The Smart Reorg utility continues processing.

### User response

None. This message is informational.

---

**HPSG0019E DFSURCDS DD MUST SPECIFY THE DFSURCDS DATA SET THAT WAS USED IN PRE-REORG JOB**

### Explanation

The data set name that is specified on the DFSURCDS DD statement does not match the DFSURCDS data set name that was used in the Pre-reorganization utility job.

### System action

The Smart Reorg utility ends with a return code of 8.

### User response

Remove the DFSURCDS DD statement or specify the correct data set on the DFSURCDS DD statement, and rerun the job.

---

**HPSG0020E DATABASE *dbd\_name* IS NOT PREPARED FOR REORGANIZATION**

### Explanation

The Smart Reorg utility cannot reorganize the indicated database. The DBD name must match the database name that was specified on the DBR or the DBIL control statement in the IMS Database Preorganization utility job (DFSURPRO).

### System action

The Smart Reorg utility ends with a return code of 8.

### User response

Specify the correct DBD name in the EXEC statement, and rerun the job.

---

**HPSG0021I [PRE | POST] REORGANIZATION PROCESS STARTED**

### Explanation

This message notifies the operator that Pre-reorganization utility or Post-reorganization utility processing has started.

### System action

The Pre-reorganization utility or the Post-reorganization utility continues processing.

### User response

None. This message is informational.

---

**HPSG0022I [PRE | POST] REORGANIZATION PROCESS ENDED (RC=00)**

### Explanation

The Pre-reorganization utility or the Post-reorganization utility job ended successfully.

### System action

The Pre-reorganization utility or the Post-reorganization utility ends.

### User response

None. This message is informational.

---

**HPSG0022W [PRE | POST] REORGANIZATION PROCESS ENDED (RC=04, RSN=xxxxxxx)**

### Explanation

The Pre-reorganization utility or the Post-reorganization utility job ended with warning conditions. A hexadecimal reason code xxxxxxxx for the warnings is shown in the message. The reason code has the following meaning:

#### Reason code Meaning

##### 80800004

One or more warning messages were issued in one or more subtasks.

##### 40100007

Old data sets could not be deleted due to an error.

##### 40100011

Automated /STA command processing failed and manual processing is required. See message HPSG2104W.

##### 40100013

One or more errors occurred in IMS Tools KB Output repository processing.

**40100016**

Clean-up processing for the work data sets failed in the Post-reorganization utility process.

**40100017**

One or more errors occurred while sending a system notification to Autonomics Director.

**System action**

The Pre-reorganization utility or the Post-reorganization utility ends.

**User response**

Refer to the accompanying warning messages and follow the required user responses for those messages.

---

**HPSG0023E**      **[PRE | POST] REORGANIZATION  
PROCESS ENDED (RC=rc,  
RSN=xxxxxxx)**

**Explanation**

The Pre-reorganization utility or the Post-reorganization utility job ended.

**Return code****Meaning****08**

Errors were detected.

**16**

A severe error occurred.

A hexadecimal reason code xxxxxxxx for the error is shown in the message. The reason code has the following meaning:

**Reason code****Meaning****80800001**

An error occurred while the task manager was being initialized.

**80800002**

An error occurred while the main process was running.

**80800003**

An error occurred while the task manager was being terminated.

**80800005**

An error occurred while the reorganization tasks were running.

**80800007**

An error occurred during report processing of the reorganization tasks.

**80800008**

An error occurred during prefix resolution processing.

**80800009**

An error occurred during image copy processing.

**80400001**

An error occurred while the control statements were analyzed.

**80200001**

An error occurred while the report manager was being initialized.

**40800001**

An error was found while the original DBD was being analyzed.

**40400002**

The status of the database was not satisfied for starting the processing.

**40400003**

An error was found while the input or output data sets for the database and indexes were being allocated.

**40400004**

An error was found while the Data Set Information report was being written.

**40200001**

An error was found while the runtime options were being checked.

**40100001**

Not all conditions for name swapping were satisfied due to one or more warning messages in a subtask or subtasks.

**40100002**

The status of the databases was not satisfied for name swapping.

**40100003**

An error was found during name swapping. Automated backout processing was not done.

**40100004**

An error was found during DBRC notification processing.

**40100008**

An error was found during name swapping. Automated backout processing was completed.

**40100009**

An error was found during name swapping. Automated backout processing failed.

**40100010**

An error was found during /START DB command processing.

**40010001**

An error occurred while the utility was being initialized.

## System action

The Pre-reorganization utility or the Post-reorganization utility job stops.

## User response

Locate the accompanying error messages and follow the required user responses for those messages. Also, see [“Recovering from Post-reorganization utility errors” on page 298](#) for user actions to recover from the error condition.

---

### **HPSG0024E THE SPECIFIED HPSGCTL DATA SET IS INCORRECT**

## Explanation

The content of the data set that is specified on the HPSGCTL DD statement is incorrect.

## System action

The Smart Reorg utility, the IPR DB Scan utility, or the Post-reorganization utility ends with a return code of 8.

## User response

Ensure that the Pre-reorganization utility job completed successfully and that the correct data set is specified on the HPSGCTL DD statement.

---

### **HPSG0025E THE RESULT DATA SET FOR *dbname* IS INCORRECT DSN=*data\_set\_name***

## Explanation

If message HPSG0122E is issued, this message indicates that the result data set for the indicated database was not found. Otherwise, this message indicates that an inconsistency was detected between the HPSTCTL data set and the result data set.

## System action

The Post-reorganization utility ends with a return code of 8 without restoring the authorization flags.

## User response

Rerun all the jobs including Pre-reorganization utility, Smart Reorg utility, IPR DB Scan utility, and Post-reorganization utility jobs.

---

### **HPSG0026I POST-PROCESSING MUST BE PERFORMED BY THE POST REORGANIZATION UTILITY**

## Explanation

The Smart Reorg utility does not perform post processing. You must run the Post-reorganization utility to complete the reorganization.

## System action

The Smart Reorg utility continues processing.

## User response

After running the Smart Reorg utility and the IPR DB Scan utility for all the databases that were processed by the Pre-reorganization utility, run the Post-reorganization utility.

---

### **HPSG0027E THE SPECIFIED DFSURCDS DATA SET IS INCORRECT**

## Explanation

The data set that is specified on the DFSURCDS DD statement is incorrect.

## System action

The Pre-reorganization utility ends with a return code of 8.

## User response

Ensure that the correct DFSURCDS data set is specified.

---

### **HPSG0028A POST REORGANIZATION PROCESS ENDED WITH AN IMAGE COPY ERROR (RC=12)**

## Explanation

Name swapping and prefix resolution and update processing completed successfully, but subsequent image copy processing ended with an error.

## System action

The Post-reorganization utility ends with a return code of 12.

## User response

Discard all the image copy data sets that were created in the Post-reorganization utility job. Identify the cause of the image copy error and resolve the problem in the Image Copy task. Then, follow the procedure for manual image copy processing, which is described in [“Performing manual image copy processing” on page 214](#), and the procedure for manual DBRC notification

processing, which is described in “Performing manual DBRC notification processing” on page 213. See also “Recovering from Post-reorganization utility errors” on page 298 for user actions to recover from the error condition.

If the problem in the Image Copy task cannot be fixed, collect the output reports of the Post-reorganization utility job and contact IBM Software Support.

If any error messages or warning messages of IMS HP Pointer Checker, which are prefixed with FABP, are issued, there might be pointer errors in the reloaded shadow database or rebuilt indexes. In this case, collect the output report of the Post-reorganization utility job and contact IBM Software Support.

---

**HPSG0029E      DFSURWF1 DD MUST SPECIFY  
THE DFSURWF1 DATA SETS THAT  
WERE USED IN REORG OR SCAN**

### Explanation

One or more DFSURWF1 data sets that were used in the Smart Reorg utility or IPR DB Scan utility job are not specified on the DFSURWF1 DD statement.

### System action

The Post-reorganization utility ends with a return code of 8.

### User response

Specify the correct data sets on the DFSURWF1 DD statement or remove the DFSURWF1 DD statement, and rerun the Post-reorganization utility job.

---

**HPSG0030E      PREVIOUS [REORG | SCAN]  
PROCESS NOT SUCCEEDED.  
DBD=dbd\_name**

### Explanation

The Smart Reorg utility job or the IPR DB Scan utility job that was run before this Post-reorganization utility job did not process the indicated DBD successfully.

### System action

The Post-reorganization utility ends with a return code of 8 after restoring the authorization flags.

### User response

Identify the error that occurred in Smart Reorg utility or IPR DB Scan utility jobs, and correct the error. Rerun all the jobs including Pre-reorganization utility, Smart Reorg utility, IPR DB Scan utility, and Post-reorganization utility jobs.

---

**HPSG0031I      DATABASE [REORG | SCAN] IS  
NEEDED: DBD=dbd\_name**

### Explanation

The indicated DBD must be reorganized or scanned in the subsequent Smart Reorg utility jobs or IPR DB Scan utility jobs.

### System action

The Pre-reorganization utility continues processing.

### User response

None. This message is informational.

---

**HPSG0032E      PREVIOUS [REORG | SCAN]  
PROCESS NOT COMPLETED.  
DBD=dbd\_name**

### Explanation

The Smart Reorg utility job or the IPR DB Scan utility job that was run before this Post-reorganization utility job has not completed yet for the indicated DBD.

### System action

The Post-reorganization utility ends with a return code of 8 without restoring the authorization flags.

### User response

Wait until the Smart Reorg utility job or the IPR DB Scan utility job ends, and then rerun the Post-reorganization utility job.

---

**HPSG0033I      BECAUSE *ctrl\_stmt* IS SPECIFIED,  
*proc\_name* PROCESSING WILL BE  
PERFORMED.**

### Explanation

The Conditional Reorganization Support Service (CRSS) determined that the database does not need to be reorganized. However, because the indicated control statement is specified, *proc\_name* processing is performed.

*proc\_name*  
*ctrl\_stmt*

**IMAGE COPY**  
CRIC=ALWAYS

**UNLOAD**  
CRUNLOAD=ALWAYS

## System action

The Smart Reorg utility continues processing.

## User response

None. This message is informational.

---

**HPSG0034I**      **BECAUSE ONE OR MORE  
DATA SETS REQUIRE NO  
REORGANIZATION, ICTYPE=B IS  
APPLIED.**

## Explanation

When CRIC=ALWAYS is specified and when the Conditional Reorganization Support Service determines that one or more databases or HALDB partitions require no reorganization, it overrides the ICTYPE control statement value with B (ICTYPE=B). This message is issued when either of the following conditions is met:

- ICTYPE=A is explicitly specified.
- ICTYPE control statement is not specified and the Smart Reorg utility applies ICTYPE=A as default.

## System action

The Smart Reorg utility continues processing.

## User response

None. This message is informational.

---

**HPSG0100E**      **GETMAIN ERROR (RC= xx) IN  
MODULE aaaaaaaa**

## Explanation

A storage area is requested in module *aaaaaaa* by using the GETMAIN macro, but an error return code of *xx* is returned.

## System action

Reorganization Manager issues a U0100 abend and the Smart Reorg utility ends with a return code of 16.

## User response

Identify the cause of the GETMAIN error by referring to *z/OS MVS Assembler Services Reference*.

---

**HPSG0101E**      **OPEN FAILED FOR DDNAME:  
ddname**

## Explanation

An attempt to open the data set identified by *ddname* failed.

## System action

Reorganization Manager issues a U0101 abend and the Smart Reorg utility ends with a return code of 16.

## User response

Check the error, and rerun the job.

---

**HPSG0102E**      **DYNAMIC *funcname* FAILED  
FOR DDNAME= *ddname* RC=*rc*,  
RSN=*rsn***

## Explanation

An attempt of dynamic allocation or unallocation for the data set that is identified by the DD name *ddname* failed. *funcname* is either ALLOCATION or UNALLOCATION. The values *rc* and *rsn* are the decimal return code and the hexadecimal reason code of the DYNALLOC macro.

- When RC=04 and RSN=1708, this message indicates that the data set does not exist.
- When RC=04 and RSN=0238, this message indicates that the TIOT space is full.

## System action

The Smart Reorg utility task or the subtask that issued the dynamic allocation request abends with a completion code of U0102, and the Smart Reorg utility job step ends with a return code of 16.

## User response

Correct the error and rerun the job. If RC is 04 and RSN is 043C, specify the DYNAMNBR parameter on the EXEC statement for the Smart Reorg utility and rerun the job. If the error cannot be resolved, keep the dump produced at the time of error and contact IBM Software Support.

## Problem determination

For the return code and the reason code from the DYNALLOC macro, see the *z/OS MVS Authorized Assembler Services Guide*.

---

**HPSG0103E**      **UNSUPPORTED LEVEL OF  
OPERATING SYSTEM**

## Explanation

The Smart Reorg utility is running on an operating system that is not supported.

## System action

The Smart Reorg utility ends with a return code of 8.

## User response

For the operating system supported by IMS Database Reorganization Expert, see “[Software prerequisites](#)” on page 39.

---

**HPSG0104E      ERROR RETURN FROM IGWASYS  
(RC=xx, RSN=zz)**

## Explanation

The Smart Reorg utility called IGWASYS, but an error return code is returned from IGWASYS. The values *xx* and *zz* indicate the return code and the reason code respectively.

## System action

The Smart Reorg utility ends with a return code of 8.

## User response

Refer to *z/OS DFSMSdfp Advanced Services* and check the meaning of the return code and reason code of IGWASYS.

---

**HPSG0105I      XTLOT IS USED FOR DATABASE  
DATA SETS**

## Explanation

Instead of TIOT (task input/output table), XTLOT (extended task input/output table) is used to allocate each HALDB data set dynamically.

## System action

The Smart Reorg utility continues processing.

## User response

None. This message is informational.

---

**HPSG0106E      BLDL MACRO FAILED FOR  
MEMBER: *member\_name* (RC=*rc*,  
RSN=*rsn*)**

## Explanation

The BLDL macro failed for member *member\_name*. The return code and the reason code from the macro call were *rc* and *rsn*.

## System action

Reorganization Manager issues a U0106 abend, and the Smart Reorg utility ends with a return code of 16.

## User response

This error is likely an internal system error. Contact IBM Software Support.

---

**HPSG0107E      OBTAIN MACRO FAILED ON  
DDNAME: *ddname* (RC=*rc*)**

## Explanation

The OBTAIN macro failed for ddname *ddname*. The return code from the macro call was *rc*.

## System action

Reorganization Manager issues a U0107 abend, and the Smart Reorg utility ends with a return code of 16.

## User response

This error is likely an internal system error. Contact IBM Software Support.

---

**HPSG0108E      FREEMAIN ERROR (RC=*rc*) IN  
MODULE *modname***

## Explanation

A storage area was requested to be freed in module *modname* by using the FREEMAIN macro, but an error return code of *rc* was returned.

## System action

Reorganization Manager issues a U0108 abend, and the Smart Reorg utility ends with a return code of 16.

## User response

This error is likely an internal system error. Contact IBM Software Support.

---

**HPSG0109E      CATALOG SEARCH ERROR: RC=*rc*  
(*yy-yy*) ENTRY=*entname***

## Explanation

A call to the DFSMS Catalog Search Interface (IGGCSI00) received a nonzero return code. The value

*rc* is the return code in hexadecimal, and the value *entname* is the entry name to be searched in the catalog.

When RC=04, the values *yy* and *zz* are the return code and the reason code in hexadecimal that are passed back from the DFSMS Catalog Manager. The meanings of the return code and reason code are described in the IDC3009I message in *z/OS MVS System Messages*.

When RC=08 and *zz* is 01, this message indicates that storage is insufficient, and you must increase the region size.

Other codes, including RC=FF, indicate an internal error.

### System action

Reorganization Manager issues a U0109 abend, and the Smart Reorg utility ends with a return code of 16.

### User response

Correct the error and rerun the job. If an internal error occurred, contact IBM Software Support.

---

**HPSG0110E      ERROR RETURN FROM IEANTCR.  
                  RETURN CODE IS *rc***

### Explanation

The Smart Reorg utility called the IEANTCR service, but an error return code is returned from the service. Value *rc* is the hexadecimal return code of the IEANTCR service.

### System action

The Smart Reorg utility ends with a return code of 8.

### User response

This error is likely an internal error. Contact IBM Software Support.

---

**HPSG0111E      PRE-PRODUCT ERROR (*reason*);  
                  PROD=*prodname***

### Explanation

The prerequisite product *prodname* is not found in libraries that are concatenated to STEPLIB, or the release level or the maintenance level of product *prodname* is not high enough for the product to run under the Smart Reorg utility. The level is the internal level of the IMS Database Reorganization Expert-support function of the product. For the software requirements, see [“Software prerequisites”](#) on page 39. Reason code *reason* shows the reason of the error.

### Reason code

#### Meaning

#### 01000002

IMS HP Unload 1.2 with APAR PK28097 is required.

#### 01000003

IMS HP Unload 1.2 with APAR PK90234 is required.

#### 01000004

IMS HP Unload 1.2 with APAR PM94788 is required.

#### 01000005

IMS HP Unload 1.2 with APAR PM75257 is required.

#### 01000006

IMS HP Unload 1.2 with APAR PI64269 is required.

#### 01000007

IMS HP Unload 1.2 with APAR PH06589 is required.

#### 01000008

IMS HP Unload 1.2 with APAR PH12333 is required.

#### 01000009

IMS HP Unload 1.2 with APAR PH22529 is required.

#### 02000003

IMS HP Load 2.1 with APAR PK28098 is required.

#### 02000004

IMS HP Load 2.1 with APAR PK88818 is required.

#### 02000005

IMS HP Load 2.1 with APAR PM94789 is required.

#### 02000006

IMS HP Load 2.1 with APAR PM75254 is required.

#### 02000008

IMS HP Load 2.1 with APAR PI69221 is required.

#### 02000009

IMS HP Load 2.1 with APAR PH04683 is required.

#### 02000010

IMS HP Load 2.1 with APAR PH28860 is required.

#### 03000001

IMS Index Builder 2.3 with APAR PQ94145 is required.

#### 03000002

IMS Index Builder 3.1 with APAR PM94790 is required.

#### 03000003

IMS Index Builder 3.1 with APAR PI72375 is required.

#### 03000004

IMS Index Builder 3.1 with APAR PH04685 is required.



**03000005**

IMS Index Builder 3.1 with APAR PH14570 is required.

**04000005**

IMS HP Image Copy 4.1 with APAR PM01166 is required.

**04000007**

IMS HP Image Copy 4.1 with APAR PH06497 is required.

**04000008**

IMS HP Image Copy 4.2 with APAR PH25480 is required.

**05000001**

IMS HP Prefix Resolution 3.1 is required.

**05000002**

IMS HP Prefix Resolution 3.1 with APAR PK28100 is required.

**05000003**

IMS HP Prefix Resolution 3.1 with APAR PH06187 is required.

**05000004**

IMS HP Prefix Resolution 3.1 with APAR PH26983 is required.

**06000001**

IMS HP Pointer Checker 2.2 with APAR PK45122 is required.

**06000002**

IMS HP Pointer Checker 3.1 with APAR PH05165 is required.

**06000003**

IMS HP Pointer Checker 3.1 with APAR PH24727 is required.

**System action**

The Smart Reorg utility ends with a return code of 8.

**User response**

Check the control statement that you specified for the IMS Database Reorganization Expert job, and check that the product or products that are required for the function that is activated by the control statement are installed and in the required maintenance level. If a required product was not installed, install it. If a required maintenance was not applied, apply the maintenance.

---

**HPSG0112E DYNAMIC ALLOCATION FAILED FOR DDNAME=ddname RC=rc, RSN=xxxx,yyyy,zzzz**

**Explanation**

An attempt of dynamic allocation with a disposition of NEW for the data set that is identified by the DD name *ddname* failed. The value *rc* is the return code from SVC99, *xxxx* is the S99ERROR contents, *yyyy* is the S99INFO contents, and *zzzz* is the S99ERSN contents.

**System action**

The Smart Reorg utility task or the subtask that issued the dynamic allocation request abends with a completion code of U0112, and the Smart Reorg utility job step ends with a return code of 16.

**User response**

Correct the error and rerun the job. If the error cannot be resolved, keep the dump produced at the time of error and contact IBM Software Support.

**Problem determination**

For the return code and the reason codes from the DYNALLOC macro, see the *z/OS MVS Authorized Assembler Services Guide*.

---

**HPSG0113E DFSURGLO IS ALREADY IN VIRTUAL STORAGE**

**Explanation**

In a ULU region type, the runtime initializer identifies the entry point DFSURGLO as the entry into HPSGTU10. This requires that module DFSURGLO is not yet in virtual storage at initialization time. This condition was not met during this execution.

**System action**

Reorganization Manager issues a U0113 abend, and the Smart Reorg utility ends with a return code of 16.

**User response**

This error is likely an internal system error. Contact IBM Software Support.

---

**HPSG0114E UNEXPECTED RETURN CODE FROM IDENTIFY**

**Explanation**

In a ULU region type, the runtime initializer issues an IDENTIFY macro. The IDENTIFY macro failed.

## System action

Reorganization Manager issues a U0114 abend, and the Smart Reorg utility ends with a return code of 16.

## User response

This error is likely an internal system error. Contact IBM Software Support.

---

**HPSG0115I DFSBRLSC FUNC=*funcname*  
RETURNED CONDITION CODE *cc***

## Explanation

IMS DBRC interface macro DFSBRLCS returned hexadecimal condition code *cc*. Keyword *funcname* is one of INIT0, INIT1, SIGNON, SIGNOFF, REORG, or SETREORG.

## System action

The Smart Reorg Driver continues processing.

## User response

If the condition code is not zero, locate DFSxxxx messages.

---

**HPSG0116E IMS LEVEL XXXX IS  
UNSUPPORTED: PROD=*prodname***

## Explanation

The maintenance level of the prerequisite product *prodname* is not high enough to support IMS release level XXXX. For example, XXXX is '1410', which means IMS 14. *prodname* can be one of:

- IMS HIGH PERFORMANCE UNLOAD
- IMS HIGH PERFORMANCE LOAD
- IMS INDEX BUILDER
- IMS HP IMAGE COPY
- IMS HP PREFIX RESOLUTION
- CONDITIONAL REORGANIZATION SUPPORT SERVICE

The Conditional Reorganization Support Service (CRSS) is a component that is included in IMS Database Reorganization Expert.

## System action

The Smart Reorg utility ends with a return code of 8.

## User response

To run the product under the IMS release level, apply the maintenance to the product.

---

**HPSG0117I APF AUTHORIZATION CHECK  
FAILED (DD: *ddname*, REASON: *nn*)**

## Explanation

The APF-authorization check module (HPSGAPF0) returned an error for the *ddname* DD statement. The reason code *nn* is used internally.

## System action

The Smart Reorg utility continues processing.

## User response

This error is likely an internal system error. Contact IBM Software Support.

---

**HPSG0118E LOAD FAILED FOR *modname*  
CC=*xxxx*, RSN=*yy***

## Explanation

A LOAD macro to load the indicated module returned an error.

## System action

The Smart Reorg utility ends with a return code of 8.

## User response

Check the meaning of the system completion code and the error reason code. See the explanation of MVS system completion code 806 to determine the meaning of the reason code. Correct the error and rerun the job.

---

**HPSG0122E DYNAMIC [ALLOCATION  
| UNALLOCATION |  
CONCATENATION] FAILURE.  
RC=*rc*, RSN=*xxxx,yyyy,zzzz***

## Explanation

An attempt to dynamically allocate, deallocate, or concatenate the data set that is identified by message HPSG0123I failed. *rc* is the return code from SVC99, *xxxx* is the S99ERROR contents, *yyyy* is the S99INFO contents, and *zzzz* is the S99ERSN contents. These values are in hexadecimal.

## System action

The Smart Reorg utility job step ends with a return code of 16.

## User response

See the *z/OS MVS Programming: Authorized Assembler Services Reference* to determine the meaning of the return code and reason code. Correct the error and rerun the job. If the problem persists, contact IBM Software Support.

---

**HPSG0123I** - DDNAME=*ddname*,  
DSN=*data\_set\_name*

## Explanation

This message follows the HPSG0122E message to show which data set is processed.

## System action

The Smart Reorg utility job step ends with a return code of 16.

## User response

None. This message is informational.

---

**HPSG0124I** IEANTCR MACRO FOR  
DFSINITSVCOPTS: RC=*rc*

## Explanation

The IEANTCR service, which creates a name-token with the name DFSINITSVCOPTS, returned the indicated return code. The code is shown in hexadecimal format. The name-token might be used in the IMS VSAM initialization.

## System action

The Smart Reorg utility continues processing regardless of the return code.

## User response

None. This message is informational.

---

**HPSG0125E** DSN=*dsname* (DDN=*ddname*)

## Explanation

This message follows message HPSG0102E to show the data set name.

## System action

See the explanation for message HPSG0102E.

## User response

See the explanation for message HPSG0102E.

---

**HPSG0200E** CONTROL STATEMENT SYNTAX  
ERROR

## Explanation

An incorrect control statement was detected by the control statement syntax checking.

## System action

The Smart Reorg utility ends with a return code of 8.

## User response

Correct the error and rerun the job.

## Problem determination

Check the control statement.

---

**HPSG0201E** UNSUPPORTED PARAMETER  
SPECIFIED: *parm\_string*

## Explanation

An incorrect parameter is detected. The incorrect parameter string is listed as *parm\_string*.

## System action

The Smart Reorg utility ends with a return code of 8.

## User response

Correct the parameter error, and rerun the job.

## Problem determination

Check the parameter specification listed as *parm\_string*.

---

**HPSG0202E** NUMBER OF *parm\_name*  
PARAMETERS EXCEEDED THE  
LIMIT: *xxx*

## Explanation

An incorrect control statement was detected by the control statement syntax checking.

## System action

The Smart Reorg utility ends with a return code of 8.

## User response

Correct the error and rerun the job.

## Problem determination

Check the control statement.

---

**HPSG0203E**      **NUMBER OF OPERANDS**  
*parm\_name* **PARAMETER**  
**EXCEEDED THE LIMIT: xxx**

## Explanation

An incorrect control statement was detected by the control statement syntax checking.

## System action

The Smart Reorg utility ends with a return code of 8.

## User response

Correct the error and rerun the job.

## Problem determination

Check the control statement.

---

**HPSG0204E**      **LENGTH ERROR IN *N-th* OPERAND**  
**OF PARAMETER: *parm\_name***

## Explanation

An incorrect control statement was detected by the control statement syntax checking.

## System action

The Smart Reorg utility ends with a return code of 8.

## User response

Correct the error and rerun the job.

## Problem determination

Check the control statement.

---

**HPSG0205E**      **ATTRIBUTE ERROR IN *N-th***  
**OPERAND OF PARAMETER:**  
*parm\_name*

## Explanation

An incorrect control statement was detected by the control statement syntax checking.

## System action

The Smart Reorg utility ends with a return code of 8.

## User response

Correct the error and rerun the job.

## Problem determination

Check the control statement.

---

**HPSG0206E**      **NUMBER OF VALUES FOR *N-th***  
**OPERAND EXCEEDED THE LIMIT:**  
*xxx*

## Explanation

An incorrect control statement was detected by the control statement syntax checking.

## System action

The Smart Reorg utility ends with a return code of 8.

## User response

Correct the error and rerun the job.

## Problem determination

Check the control statement.

---

**HPSG0207E**      ***N-th* OPERAND IS REQUIRED FOR**  
**PARAMETER: *parm\_name***

## Explanation

An incorrect control statement was detected by the control statement syntax checking.

## System action

The Smart Reorg utility ends with a return code of 8.

## User response

Correct the error and rerun the job.

## Problem determination

Check the control statement.

---

**HPSG0208I**      **BLANK LINES WERE IGNORED**

## Explanation

This is just an information message.

### System action

None.

### User response

None. This message is informational.

---

**HPSG0209E SYNTAX ERROR IN STATEMENT  
BLOCK IDENTIFIER**

### Explanation

A syntax error was found while a statement block identifier was parsed.

### System action

The Smart Reorg utility ends with a return code of 8.

### User response

Refer to Chapter 9, “Smart Reorg control statements,” on page 117, and specify a control statement block correctly.

---

**HPSG0210E UNEXPECTED STATEMENT BLOCK  
NAME: *block\_name***

### Explanation

The name specified as the name for the control statement block is not supported. The supported names are the following: REORG, UNLOAD, RELOAD, and INDEXBLD.

### System action

The Smart Reorg utility ends with a return code of 8.

### User response

Refer to Chapter 9, “Smart Reorg control statements,” on page 117, and specify a correct control statement block name.

---

**HPSG0211E DUPLICATE STATEMENT BLOCK:  
*block\_name***

### Explanation

The same control statement block was specified more than once.

### System action

The Smart Reorg utility ends with a return code of 8.

### User response

Remove unnecessary statement blocks or merge the blocks into a block, and rerun the job.

---

**HPSG0212E *N-th* OPERAND MUST BE *text***

### Explanation

The *N-th* operand of the control statement must be specified as indicated by the string *text*.

### System action

The Smart Reorg utility ends with a return code of 8.

### User response

Correct the control statement as indicated by the message, and rerun the job.

---

**HPSG0213E UNSUPPORTED PIPE-ID IS  
SPECIFIED**

### Explanation

The pipe ID specified in the control statement is incorrect.

### System action

The Smart Reorg utility ends with a return code of 8.

### User response

Specify a correct pipe ID or remove unnecessary pipe control statements. Then, rerun the job.

---

**HPSG0214E UNSUPPORTED OUTPUT FORMAT  
IS SPECIFIED**

### Explanation

The unload format specified for SYSUT2 is not supported in parallel reorganization.

### System action

The Smart Reorg utility ends with a return code of 8.

### User response

Specify the unload format supported in parallel reorganization, and rerun the job.

---

**HPSG0215E INPUT DD NAME OTHER THAN  
DFSUINPT CANNOT BE SPECIFIED**

## Explanation

You cannot specify a DD name other than DFSUINPT for the INPUT control statement for the Reload task.

## System action

The Smart Reorg utility ends with a return code of 8.

## User response

Specify DFSUINPT for the INPUT control statement, or do not specify the DD name. Correct the control statement, and rerun the job.

---

**HPSG0216E SYNTAX ERROR IN DDNMAP  
PATTERN STRING FOR *parameter***

## Explanation

A syntax error is found in the DDNMAP control statement. The pattern specified for the DD name identified by the string *parameter* has a syntax error. *parameter* is one of "ORIGINAL DD" or "SHADOW DD." The pattern string (*aaaaaaaa*) for original DD and the pattern string (*bbbbbbbb*) for shadow DD in a DDNMAP control statement DDNMAP=(*aaaaaaaa,bbbbbbbb*) must be specified as follows:

- The length of *aaaaaaaa* and *bbbbbbbb* must be eight.
- Only the minus symbol (-) and the percent symbol (%) can be specified for each character in string *aaaaaaaa*, but at least one percent symbol must be specified.
- Minus symbols must be specified in string *bbbbbbbb* at the same position as in string *aaaaaaaa*.
- In string *bbbbbbbb*, an alphanumeric character other than the percent symbol and the minus symbol must be specified at the position where percent symbol is specified in string *aaaaaaaa*.
- The position, in string *bbbbbbbb*, where the last percent symbol is specified must not exceed the length of the shortest original DD name.

## System action

The Smart Reorg utility ends with a return code of 8.

## User response

Correct the syntax error or specify the shadow DD names explicitly, and rerun the job.

---

**HPSG0217E PATTERN MUST BE SPECIFIED IN  
THE FIRST DDNMAP STATEMENT**

## Explanation

If you specify the DD name mapping by a pattern, the pattern must be specified in the first DDNMAP control statement.

## System action

The Smart Reorg utility ends with a return code of 8.

## User response

Move the DDNMAP control statement before any other DDNMAP statement, and rerun the job.

---

**HPSG0218E MAPPING PATTERN IS SPECIFIED  
TWICE**

## Explanation

The DDNMAP control statement that specifies a mapping pattern was specified more than once.

## System action

The Smart Reorg utility ends with a return code of 8.

## User response

Select one of the DDNMAP control statements and specify the selected statement before any other DDNMAP statement, and rerun the job.

---

**HPSG0219E DDNMAP FOR THE ORIGINAL DD  
xxxxxxx IS SPECIFIED TWICE**

## Explanation

The DDNMAP control statement is specified for the original DD name xxxxxxxx more than once.

## System action

The Smart Reorg utility ends with a return code of 8.

## User response

Select one of the DDNMAP control statements for the DD, and rerun the job.

---

**HPSG0220E DDNAME xxxxxxxx IS NOT  
DEFINED IN THE DBD**

## Explanation

The name xxxxxxxx specified as an original DD name is not defined in the DBD.

## System action

The Smart Reorg utility ends with a return code of 8.

## User response

Check if the correct DBD is specified. If the correct DBD is specified, check the DD names defined in the DBD. Correct the error, and rerun the job.

---

**HPSG0221E DDNAME xxxxxxxx IS RESERVED FOR SYSTEM USE**

## Explanation

The DD name xxxxxxxx specified as the shadow DD name or generated by a mapping pattern in the DDNMAP control statement is reserved for system use. For the reserved DD names, see [“DDNMAP control statement”](#) on page 133.

## System action

The Smart Reorg utility ends with a return code of 8.

## User response

Specify another DD name, and rerun the job.

---

**HPSG0222E DDNMAP GENERATED DUPLICATE SHADOW DDNAME xxxxxxxx**

## Explanation

The shadow DD name xxxxxxxx is specified by DDNMAP control statements for more than one original DD name.

## System action

The Smart Reorg utility ends with a return code of 8.

## User response

Correct the DDNMAP control statement, and rerun the job.

---

**HPSG0223E DDNAME xxxxxxxx GENERATED BY DDNMAP IS RESERVED FOR SYSTEM USE**

## Explanation

The shadow DD name xxxxxxxx generated by a mapping pattern specified in a DDNMAP control statement is reserved for system use. For the reserved DD names, see [“DDNMAP control statement”](#) on page 133.

## System action

The Smart Reorg utility ends with a return code of 8.

## User response

Correct the DDNMAP control statement that specifies the mapping pattern or specify the shadow DD names explicitly, and rerun the job.

---

**HPSG0224E CONTROL STATEMENT BLOCK IS NOT SPECIFIED YET**

## Explanation

A control statement is specified with no preceding line that specifies a control statement block. A control statement block must be specified before a control statement is specified.

## System action

The Smart Reorg utility ends with a return code of 8.

## User response

Add a line that specifies the appropriate control statement block, or move the control statement in the appropriate control statement block that has been already coded.

---

**HPSG0225E xxxxxxxx STATEMENT IS NOT SUPPORTED**

## Explanation

The control statement xxxxxxxx is not supported in parallel reorganization. For details of control statements supported in parallel reorganization, see [Chapter 9, “Smart Reorg control statements,”](#) on page 117.

## System action

The Smart Reorg utility ends with a return code of 8.

## User response

Remove the control statement, and rerun the job. If the control statement is necessary for your processing, use the stand-alone utilities instead of the Smart Reorg utility.

---

**HPSG0226E ERROR IN STATEMENT BLOCK SEQUENCE**

## Explanation

The sequence of the control statement blocks is incorrect. The control statement blocks must be specified in the following order: (REORG), (CONDREORG), (UNLOAD), (RELOAD), (INDEXBLD), (PREFIXRES). For more information, see [Chapter 9, "Smart Reorg control statements," on page 117.](#)

## System action

The Smart Reorg utility ends with a return code of 8.

## User response

Reorder the control statement blocks, and rerun the job.

---

**HPSG0227E      DUPLICATE STATEMENT:  
statement**

## Explanation

The control statement *statement* is specified more than once.

## System action

The Smart Reorg utility ends with a return code of 8.

## User response

Remove one of the statements, and rerun the job.

---

**HPSG0228E      DDNAME *ddname* MUST NOT BE  
SPECIFIED**

## Explanation

The DD name *ddname* must not be specified in the DDNMAP control statement.

## System action

The Smart Reorg utility ends with a return code of 8.

## User response

Remove the DDNMAP control statement or specify a correct DD name.

---

**HPSG0229E      DBRC MUST BE ACTIVE WHEN  
statement IS SPECIFIED**

## Explanation

DBRC must be active when one or both of NAMESWAP=YES and, IMSCMD=YES or DBRCAUTHCMD=YES are specified. DBRC must be

active also when DBSHARE control statement, either DBSHARE=NO or DBSHARE=YES, is coded.

## System action

The Smart Reorg utility ends with a return code of 8.

## User response

Specify DBRC=Y subparameter in the EXEC parameter, and rerun the job. If you do not want to activate DBRC in your parallel reorganization job, remove all the control statements mentioned in the Explanation section.

---

**HPSG0230E      CONTROL STATEMENT ERROR**

## Explanation

An error or errors were found while the control statements were being analyzed.

## System action

The Smart Reorg utility ends with a return code of 8.

## User response

See the messages printed in the HPSIN Control Statement report and correct the error or errors.

---

**HPSG0231E      STATEMENT MUST NOT END WITH  
A COMMA**

## Explanation

The control statement must not end with a comma (,). A value must be specified explicitly after a comma.

## System action

The Smart Reorg utility ends with a return code of 8.

## User response

Specify a parameter after the comma or remove the comma, and rerun the job.

---

**HPSG0232E      INDEX CANNOT BE BUILT INTO  
THE CURRENT DATA SET WHEN  
DBSHARE=YES**

## Explanation

INDEXBLD=YES,CURRENT or PSINDEXBLD=YES,CURRRENT was specified for the job, but DBSHARE=YES was also specified. If DBSHARE=YES is specified, the secondary indexes



must be built into new data sets other than those used online.

### System action

The Smart Reorg utility ends with a return code of 8.

### User response

Specify INDEXBLD=YES,NEW, PSINDEXBLD=YES,NEW, or specify DBSHARE=NO.

---

**HPSG0233E**      **PIPE BLOCK SIZE (PIPE ID=*n*) IS TOO SMALL. MINIMUM PIPEBLKSZ IS *size***

### Explanation

The block size of IPRPIPE for pipe ID *n*, which is specified on the PIPEBLKSZ control statement, is too small. *size* shows the value that is specified on the PIPEBLKSZ control statement.

### System action

The Smart Reorg utility ends with a return code of 8.

### User response

Increase the value on the PIPEBLKSZ control statement and rerun the job.

---

**HPSG0235E**      **PARTITION *partname* IS NOT DEFINED FOR *dbdname***

### Explanation

The partition *partname* that is specified in the PARTITION control statement is not defined for the HALDB master database *dbdname*.

### System action

The Smart Reorg utility ends with a return code of 8.

### User response

Check whether the partition name specified in the PARTITION control statement is correct.

---

**HPSG0236E**      ***xxxxxxx* STATEMENT CANNOT BE SPECIFIED IN *bbbbbbbb* BLOCK**

### Explanation

The control statement *xxxxxxx* cannot be specified in the control statement block *bbbbbbbb*. For details about that control statements supported in parallel

reorganization, see [Chapter 9, “Smart Reorg control statements,”](#) on page 117.

### System action

The Smart Reorg utility ends with a return code of 8.

### User response

Remove the control statement from the control statement block indicated in the message.

---

**HPSG0238E**      **INPUT DATABASE MUST BE DYNAMICALLY ALLOCATED**

### Explanation

Because the database to be reorganized is a HALDB, the input database data sets must be dynamically allocated.

### System action

The Smart Reorg utility ends with a return code of 8.

### User response

Specify the control statement DYNALLOC=YES or DYNALLOC=(YES,*xxx,xxx*) in HPSIN DD.

---

**HPSG0239I**      **CONTROL STATEMENT IS IGNORED: *keyword***

### Explanation

The control statement *keyword* cannot be specified in the Smart Reorg utility. The control statement is ignored.

### System action

The Smart Reorg utility continues processing.

### User response

None. This message is informational.

---

**HPSG0240E**      **UNSUPPORTED COMBINATION:*xxxxxxx*, *yyyyyyy***

### Explanation

The combination of the control statements *xxxxxxx* and *yyyyyyy* are not supported.

### System action

The Smart Reorg utility ends with a return code of 8.

## User response

Select only one of these statements, and remove the rest. On how to specify the control statements, see “Control statements for the Smart Reorg Driver” on page 118.

---

**HPSG0241E**      **xxxxxxxxxxxxx IS NOT A VALID KEYWORD**

## Explanation

The string *xxxxxxxxxxxxx* is not valid as a control statement keyword.

## System action

The Smart Reorg utility ends with a return code of 8.

## User response

Check the release level and maintenance level of the products used under the Smart Reorg utility to see whether the keyword is supported.

---

**HPSG0243E**      **statement CANNOT BE SPECIFIED FOR THIS DATABASE; REASON=*rsn***

## Explanation

The control statement *statement* cannot be specified because of the reason shown by the reason code *rsn*. The reason code *rsn* is one of the following values:

### *rsn*

#### Description

#### 01

Internal logical relationships are defined in the HDAM or HIDAM database. ICTYPE=A cannot be specified for this database. Remove ICTYPE=A and specify PREFIXRES=YES.

#### 02

External logical relationships are defined in the HDAM or HIDAM database. IC=YES cannot be specified for this database.

#### 03

A logical relationship is defined in the HISAM database. IC=YES cannot be specified for this database.

## System action

The Smart Reorg utility ends with a return code of 8.

## User response

Follow the required action that is indicated in the description of the reason code.

---

**HPSG0244E**      **PREFIXRES=YES MUST BE SPECIFIED TO TAKE IMAGE COPIES**

## Explanation

PREFIXRES=YES is required for taking image copies because the database has internal logical relationships.

## System action

The Smart Reorg utility ends with a return code of 8.

## User response

Specify PREFIXRES=YES or specify IC=NO.

---

**HPSG0245E**      **THE *keyword* STATEMENT IS REQUIRED WHEN *statement***

## Explanation

When *statement* is specified, the *keyword* control statement is required. The possible combinations of *keyword* and *statement* are:

### keyword

#### statement

#### TOSIXCFGRP

IMSCMD=YES,TOSI

#### ADDBGRP

ADXCFGRP

#### IC=YES

CRIC

## System action

The Smart Reorg utility ends with a return code of 8.

## User response

Add the keyword control statement, and rerun the job.

---

**HPSG0246E**      **IMSCMDOPT STATEMENT CAN ONLY BE SPECIFIED ONCE WHEN FIRST PARM IS ALL**

## Explanation

Two or more IMSCMDOPT control statements are specified. However, when the first parameter of an IMSCMDOPT control statement specifies ALL, only one

IMSCMDOPT control statement can be specified in the JCL stream.

### System action

The Smart Reorg Driver ends with a return code of 8.

### User response

Remove the IMSCMDOPT control statement that specifies ALL for its first parameter, or remove other IMSCMDOPT control statements, and rerun the job.

---

**HPSG0247E DFSURCDS CONTAINS INFORMATION ABOUT DATABASE xxxxxxxx WHICH IS NOT SUPPORTED**

### Explanation

The data set specified in the DFSURCDS DD contains information about a database that has an unsupported database organization type.

### System action

The Pre-reorganization utility ends with a return code of 8.

### User response

Re-create the DFSURCDS data set by running the IMS Database Prereorganization utility (DFSURPRO), and rerun the Pre-reorganization utility job.

---

**HPSG0248E WHEN HPSGCTL DD EXISTS, FOLLOWING OPTION IS INVALID: control\_statement**

### Explanation

The Smart Reorg utility found the indicated control statement option. However, this option is not supported when an HPSGCTL DD statement is specified.

### System action

The Smart Reorg utility ends with a return code of 8.

### User response

Remove the control statement, and rerun the Smart Reorg utility job.

---

**HPSG0249E SYNTAX ERROR IN PARTITION STATEMENT: text**

### Explanation

An incorrect PARTITION statement is specified in the HPSIN data set. *text* describes the syntax error.

#### *text*

#### Description

#### NOT POSITIVE NUMBER

Zero or a negative number is not allowed for the second operand.

#### TOO MANY PARTNAMES

If \*ALL is specified once, no partition name can be specified. If the number of the partitions is specified in the second operand, two or more partition names cannot be specified. If a list of partition names is specified, more than 1001 partition names cannot be specified.

### System action

The Smart Reorg utility ends with a return code of 8.

### User response

Correct the control statement, and rerun the Smart Reorg utility job.

---

**HPSG0250E DUPLICATE NAME IN PARTITION STATEMENT**

### Explanation

The Smart Reorg utility detected duplicate partition names on one or more PARTITION control statements.

### System action

The Smart Reorg utility ends with a return code of 8.

### User response

Remove the duplicated partition name, and rerun the Smart Reorg utility job.

---

**HPSG0251E PSINDEXBLD UPDATE MODE IS NOT ALLOWED WITH NEWDBD**

### Explanation

The UPDATE mode option of the PSINDEXBLD control statement cannot be specified with the NEWDBD control statement because all of the PSINDEX records must be rebuilt.

### System action

The Smart Reorg utility ends with a return code of 8.

## User response

Specify LOAD for the PSINDEXBLD control statement so that the PSINDEX processing runs in load mode, and rerun the job.

---

**HPSG0252E ACCESS OPTION IN STARTDB STATEMENT IS NOT ALLOWED WHEN /STA DB GLOBAL**

## Explanation

The access option of the STARTDB control statement cannot be specified when the GLOBAL option of the IMSCMDOPT control statement is enabled for the /STA command.

## System action

The Smart Reorg utility ends with a return code of 8.

## User response

Remove the access option from the STARTDB control statement, or specify the LOCAL option for the IMSCMDOPT control statement for the /STA command.

---

**HPSG0253E INCORRECT EVENT OR RC IN RC\_CHANGE STATEMENT**

## Explanation

An invalid event name or return code is specified for the RC\_CHANGE control statement. The event name must be either POLICY.ACTION.REORG or POLICY.EXCEPTIONS.CRITICAL. The return code must be in the range of 1 - 100. If RC\_CHANGE=NONE is specified, a return code value must not be specified.

## System action

The Smart Reorg utility ends with a return code of 8.

## User response

Correct the RC\_CHANGE control statement error, and rerun the job.

---

**HPSG0300E DBD *dbdname* IS NOT FOUND IN DBD LIBRARY *dd\_name***

## Explanation

The indicated DBD member was not found in the DBD library that is specified on the indicated DD statement.

## System action

The Smart Reorg utility ends with a return code of 8.

## User response

Ensure that the indicated DBD member exists in the DBD library and that the DD statement for the indicated DD name points to the correct data set. Correct the error and rerun the job.

---

**HPSG0301E UNSUPPORTED DATABASE ORGANIZATION**

## Explanation

The database organization is not supported by the Smart Reorg utility.

## System action

The Smart Reorg utility ends with a return code of 8.

## User response

Check if the correct DBD is used. If the correct one is used, consider using the stand-alone reorganization utilities of IMS Database Reorganization Expert.

---

**HPSG0302E CHANGE OF SEGMENT HIERARCHY IS NOT SUPPORTED**

## Explanation

You cannot change the segment hierarchy in parallel reorganization. For the DBD changes supported in parallel reorganization, see [“NEWDBD control statement”](#) on page 149.

## System action

The Smart Reorg utility ends with a return code of 8.

## User response

Check if the correct DBD is used as the new DBD. If the correct one is used, consider using the stand-alone reorganization utilities of IMS Database Reorganization Expert.

---

**HPSG0303E UNSUPPORTED DBD CHANGE:  
DBD=*dbd\_name* [(*change,ii*)  
| ,DD=*ddname* (*change,ii*)  
| ,SEGM=*segmname* (*change,ii*)]**

## Explanation

An unsupported DBD change is requested by the new DBD that is specified by the NEWDBD control statement. The change for the data set group *ddname* or the segment *segmname* is one of the following change types and the change is not supported. *ii* indicates the internal code.

**Change  
Description**

**ACCESS**

Changing the DB organization or the access method

**DSGROUP**

Changing the data set group

**HIERARCHY**

Changing the segment position in the hierarchy

**SEGM\_NAME**

Changing the segment name

**SEGM\_LEN**

Changing the segment length type; fixed or variable

**SEGM\_KEY**

Changing the segment sequence key field

**COMPRTN**

Changing the COMPRTN= parameter or the compressed key

**LOGICAL**

Changing the logical relationship

**INDEX**

Changing the index relationship

**RANDOMIZER**

Changing the randomizing module parameter for PHDAM

For the DBD changes supported in parallel reorganization, see [“NEWDBD control statement” on page 149](#).

**System action**

The Smart Reorg utility ends with a return code of 8. If DECODEDBD=YES and DECODESDX is specified, the DBD sources are produced in the HPSOUT2 data sets. The DBD snap dump for the original DBD and the new DBD is produced in the HPSSNAP data set.

**User response**

Check if the correct DBD is used as the new DBD. If the correct one is used, consider using the stand-alone reorganization utilities of IMS Database Reorganization Expert.

---

**HPSG0304E      INCORRECT DFSMDA MEMBER:  
                  xxxxxxx**

**Explanation**

A DFSMDA member xxxxxxxx is loaded, but it does not have a correct format. The eye-catcher MDA is not found in it.

**System action**

The Smart Reorg utility ends with a return code of 8.

**User response**

Make sure that the correct library of DFSMDA members is specified in the STEPLIB or the JOBLIB concatenation. Correct the error, and rerun the job.

---

**HPSG0305E      INFORMATION FOR DDNAME  
                  xxxxxxx IS NOT FOUND IN  
                  DFSMDA MEMBER: yyyyyyy**

**Explanation**

The data set information associated with the DD name xxxxxxxx is not found in the DFSMDA member yyyyyyy. The dynamic allocation for the DD xxxxxxxx cannot be done.

**System action**

The Smart Reorg utility ends with a return code of 8.

**User response**

Check if the correct DFSMDA member is used. Correct the error and rerun the job.

---

**HPSG0306E      DEVTYPE MACRO FAILED ON  
                  DDNAME: ddname (RC=rc)**

**Explanation**

An error occurred when the DEVTYPE macro is used to get information about the device that is associated with the DD name *ddname*. The value *rc* shows the return code from DEVTYPE macro.

**System action**

Reorganization Manager issues a U0306 abend, and the Smart Reorg utility ends with a return code of 16.

**User response**

Check if the DD statement for the indicated DD name points to the correct data set. Correct the error and rerun the job.

If the indicated DD name (*ddname*) is IMSD0000 or IMSDSTAG, this error is likely an internal system error. Contact IBM Software Support.

---

**HPSG0307E      DDNAME ddname IS NOT FOUND**

## Explanation

No DD statement is coded in the JCL stream for the DD name *ddname* although the dynamic allocation is not designated for the DD statement.

## System action

The Smart Reorg utility ends with a return code of 8.

## User response

Specify the DD statement for the DD name or specify the dynamic allocation of the DD statement. On how to specify the dynamic allocation, see [“DYNALLOC control statement” on page 136](#).

If the indicated DD name (*ddname*) is IMSD0000 or IMSDSTAG, this error is likely an internal system error. Contact IBM Software Support.

---

**HPSG0308E RDJFCB MACRO FAILED ON DDNAME: *ddname* (RC=*rc*)**

## Explanation

The RDJFCB MACRO failed for DD name *ddname*. The return code from the macro call was *rc*.

## System action

Reorganization Manager issues a U0308 abend, and the Smart Reorg utility ends with a return code of 16.

## User response

This error is likely an internal system error. Contact IBM Software Support.

---

**HPSG0309E DATA SET NAME FOR DDNAME xxxxxxxx IS TOO LONG**

## Explanation

The data set name of the original DD name xxxxxxxx is longer than 42 characters. If DYNALLOC=(*xxx*,YES) or NAMESWAP=YES is specified, the name must be 42 or fewer characters because Smart Reorg utility appends two characters to the name.

## System action

The Smart Reorg utility ends with a return code of 8.

## User response

Make the name shorter or specify DYNALLOC=(*xxx*,NO) and NAMESWAP=NO. If it is a secondary index, specify DYNALLOC=(*xxx*,*xxx*,NO). For more information, see

[“DYNALLOC control statement” on page 136](#) and [“NAMESWAP control statement” on page 147](#).

---

**HPSG0310E DYNALLOC PROCESSING FAILED**

## Explanation

DYNALLOC=YES was specified, but the dynamic allocation of an original or a shadow database data set failed. The preceding HPSGxxxxE message indicates the reason of the error.

## System action

The Smart Reorg utility ends with a return code of 8.

## User response

Refer to the Programmer Response of the preceding message.

---

**HPSG0311I DATA SET FOR ORIGINAL SECONDARY INDEX: *dbdname* NOT FOUND**

## Explanation

The original secondary index database *dbdname* data set is not found. If NAMESWAP=YES is specified, only the cluster name of the data set is renamed. If NAMESWAP=NO is specified, the Smart Reorg utility generates the IDCAMS command stream to rename only the cluster name for the data set in the IDCAMS Command Stream for Name Swapping report. For the VSAM component names printed in the Data Set Information report for the original index, see [“Data Set Information report” on page 259](#).

## System action

The Smart Reorg utility continues processing.

## User response

If necessary, rename the component names. For details, see [“Performing manual name swapping” on page 212](#). If you do not need to rename the component names, ignore this message.

---

**HPSG0312E NAME SWAP CANNOT BE DONE: *reason***

## Explanation

The name swapping cannot be done because of the reason indicated by string *reason*.

**reason**

**Description**

**LENGTH OF DATA SET NAME**

The length of the name of the original data set or the VSAM component is more than 42.

**WARNING IN xxxxxx TASK**

A warning message or messages were issued from the subtask that is indicated by xxxxxx. xxxxxx is one of the following tasks:

- UNLOAD for Unload task
- RELOAD for Reload task
- IDXBLD for Index Builder task
- PFXRES for Prefix Resolution task
- IMGCPY for Image Copy task

**ERROR IN IMGCPY TASK**

An error or errors occurred in the Image Copy task and the task ended with a return code of 8 or larger.

**System action**

The Smart Reorg utility continues processing with NAMESWAP=NO setting, and ends with a return code of 8 or 12.

**User response**

If the *reason* is LENGTH OF DATA SET NAME and no error is found in the reorganization process, prepare the IDCAMS command stream for name swapping by yourself referring to the sample stream shown in “Result of Name Swapping report” on page 263, then perform the post-reorganization processing manually.

If the *reason* is WARNING IN xxxxxx TASK, check the return code and reason code of the corresponding task. If you can ignore the warning issued from the task and no other error is found in the reorganization process, perform the post-reorganization processing manually. For details, see “Post-reorganization processing” on page 212.

If the *reason* is ERROR IN IMGCPY TASK, see the Explanation and Programmer Response of message HPSG0016A that follows this message.

---

**HPSG0313I IDCAMS SERVICE ENDED WITH ERROR CC=cc (command)**

**Explanation**

An error occurred when the program IDCAMS was called to perform *command*. The decimal value *cc* is the condition code returned by IDCAMS.

**System action**

The Smart Reorg utility continues processing.

**User response**

Confirm the reason of the error shown in the following messages or in the appropriate report about the result of the IDCAMS commands.

---

**HPSG0314I NOTIFY.REORG DBD(*dbdname*) DDN(*ddname*)**

**Explanation**

The Smart Reorg utility successfully notified DBRC about the reorganization of the data set identified by the DD name *ddname*.

**System action**

The Smart Reorg utility continues processing.

**User response**

None. This message is informational.

For details of the result of the notification, see “DBRC Notification Processing report” on page 266.

---

**HPSG0314E NOTIFY.REORG DBD(*dbdname*) DDN(*ddname*)—ERROR(CC=*xx*)**

**Explanation**

An error occurred during the DBRC notification processing. The error occurred when the NOTIFY.REORG command was issued for the data set identified by the DD name *ddname*.

The condition code returned from the DBRC utility (DSPURX00) is *xx*.

**System action**

The Smart Reorg utility ends with a return code of 8.

**User response**

Refer to the messages issued from the DBRC utility, and identify the cause of the error. The messages are printed in the DBRC Notification Processing report.

---

**HPSG0315I NOTIFY.UIC DBD(*dbdname*) DDN(*ddname*)**



## Explanation

The Smart Reorg utility issued a NOTIFY.UIC command, which turns off the RECON ICNEEDED flag, to the data set specified by the DD name *ddname*, and was successful.

## System action

The Smart Reorg utility continues processing.

## User response

None. This message is informational.

For details about the result of the notification, see "DBRC Notification Processing report" on page 266.

---

**HPSG0315E**      **NOTIFY.UIC DBD(*dbdname*)  
DDN(*ddname*)—ERROR(CC=*xx*)**

## Explanation

An error occurred when the Smart Reorg utility issued a NOTIFY.UIC command to turn off the ICNEEDED flag for the data set identified by the DD name *ddname*. The condition code returned from the DBRC utility (DSPURX00) is *xx*.

## System action

The Smart Reorg utility ends with a return code of 8.

## User response

Refer to the messages issued from the DBRC utility, and identify the cause of the error. The messages are printed in the DBRC Notification Processing report.

---

**HPSG0316I**      **CHANGE.DB DBD(*dbdname*)  
*parameter***

## Explanation

The CHANGE.DB command has been successfully completed for the database or HALDB partition *dbdname*.

*parameter* is one of the following:

- OLRDBDS(A)
- READON
- NOAUTH
- AUTH READOFF
- NOAUTH READOFF
- AUTH READON
- NOAUTH READON

- NOPINIT

## System action

The Smart Reorg utility continues processing.

## User response

None. This message is informational.

---

**HPSG0316E**      **CHANGE.DB DBD(*dbdname*)  
*parameter* --- ERROR (CC=*xx*)**

## Explanation

An error occurred when the Smart Reorg utility issued the CHANGE.DB command for the database or a HALDB partition *dbdname*. The condition code returned from DSPURX00 is *xx*.

### *parameter*

#### Report of Reference

#### OLRDBDS(A)

DBRC AUTHORIZATION PROCESSING FOR NAME SWAPPING

#### READON

DBRC AUTHORIZATION PROCESSING FOR REORGANIZATION

#### NOAUTH

DBRC AUTHORIZATION PROCESSING FOR REORGANIZATION

or

DBRC AUTHORIZATION PROCESSING FOR NAME SWAPPING

#### AUTH READOFF

#### NOAUTH READOFF

#### AUTH READON

#### NOAUTH READON

#### NOPINIT

DBRC NOTIFICATION PROCESSING

If the preceding HPSG0410I message was issued, see the report titled "DBRC PROCESSING FOR RESTORING AUTHORIZATION FLAGS."

## System action

The Smart Reorg utility ends with a return code of 8.

## User response

Refer to the messages issued from the DBRC utility, and identify the cause of the error. The messages are printed in the HPSOUT2 data set.



---

**HPSG0319E**      **DFSMDA MEMBER FOR  
[DATABASE|P-INDEX|S-INDEX ]  
dddddddd IS NOT FOUND**

### Explanation

The DFSMDA member for the database (DATABASE), primary index (P-INDEX), or secondary index (S-INDEX) *dddddddd* was not found.

### System action

The Smart Reorg utility ends with a return code of 8.

### User response

Check whether the correct library of DFSMDA members was used.

---

**HPSG0320E**      **keyword MUST NOT BE SPECIFIED  
BECAUSE xxxxxxxx IS NOT  
REGISTERED TO DBRC**

### Explanation

The indicated control statement *keyword* cannot be specified for the job because the database or index *xxxxxxx* is not registered to DBRC.

### System action

The Smart Reorg utility ends with a return code of 8.

### User response

If you want to use the indicated control statement, register the database and its indexes to DBRC. Otherwise, run the job with DBRC inactive. If you do not want to use the indicated control statement, remove the control statement, and rerun the job.

---

**HPSG0321E**      **statement MUST NOT BE  
SPECIFIED BECAUSE xxxxxxxx IS  
NOT REGISTERED TO DBRC**

### Explanation

The indicated control statement *statement* cannot be specified for the job because the database or index *xxxxxxx* is not registered to DBRC.

### System action

The Smart Reorg utility ends with a return code of 8.

### User response

If you want to specify the indicated control statement, register the database and its indexes to DBRC. If you

do not want to use the indicated control statement, remove the control statement, and rerun the job.

---

**HPSG0323E**      **MODULE IS NOT AUTHORIZED**

### Explanation

APF authorization is required for this type of run of the Smart Reorg utility.

### System action

The Smart Reorg utility ends with a return code of 8.

### User response

Correct the error and rerun the job.

---

**HPSG0324E**      **SUBSYSTEM *imsid* INACTIVE**

### Explanation

IMS *imsid* is not active. IMS command processing is not available with this IMS.

### System action

The Smart Reorg utility ends with a return code of 8.

### User response

If you want to use another IMS, specify the IMSID with the IMSID= keyword. Rerun the job.

---

**HPSG0325E**      **E-MCS CONSOLE BUSY**

### Explanation

IMS command processing is not available because the E-MCS console is busy.

### System action

The Smart Reorg utility ends with a return code of 8.

### User response

Wait for another job to finish using the E-MCS console. Rerun the job.

---

**HPSG0326E**      **IMS COMMAND NOT  
RECOGNIZED: *iiicc* text**

### Explanation

IMS command string is not recognized by the IMS online subsystem. *iii* is IMSID as the command

recognition character. *ccc* is the IMS command keyword. *text* is the subsequent IMS command string.

### System action

The Smart Reorg utility ends with a return code of 8.

### User response

Check if the correct CMDMCS= parameter is specified in the IMS online subsystem procedure. Correct the error and rerun the job.

---

**HPSG0327E**      **IMS COMMAND NOT AUTHORIZED:**  
*iiii* *ccc text*

### Explanation

IMS command is not authorized by the IMS online subsystem. *iiii* is the IMSID as the command recognition character. *ccc* is the IMS command keyword. *text* is the subsequent IMS command string.

### System action

The Smart Reorg utility ends with a return code of 8.

### User response

Check if the correct authorization is given for the command from E-MCS consoles. Correct the error and rerun the job.

---

**HPSG0329E**      **DUMMY SPECIFIED FOR xxxxxxxx**  
**DD STATEMENT**

### Explanation

DUMMY is specified for one or both of the DD name IMS and the DD name xxxxxxxx that is specified in the NEWDBD control statement. DUMMY is not allowed for these DD statements.

### System action

The Smart Reorg utility ends with a return code of 8.

### User response

Correct the DD statement, and rerun the job.

---

**HPSG0330I**      **POST PROCESSING STARTS**

### Explanation

This is an information message that tells the operator that the post-reorganization processing has started.

### System action

The Smart Reorg utility continues processing.

### User response

None. This message is informational.

---

**HPSG0331I**      **MANUAL POST-PROCESSING IS**  
**REQUIRED**

### Explanation

The automated data set name swapping has not been done because NAMESWAP=YES was not specified. You must perform the name swapping manually.

### System action

The Smart Reorg utility continues processing.

### User response

Perform the name swapping, and optionally the DBRC notification processing manually. For details, see “Post-reorganization processing” on page 212.

---

**HPSG0332W**      **VERIFICATION IS REQUIRED**  
**BEFORE MANUAL POST-**  
**PROCESSING - reason**

### Explanation

The automated name swapping has not been performed because NAMESWAP=NO. You need to do manual post processing. Before the manual post processing, however, you need to verify whether the result of the reorganization is acceptable. The string *reason* shows why the verification is required.

#### *reason*

##### Description

#### EXTERNAL REFERENCE

The database has a logical relationship with another database.

#### LENGTH OF DATA SET NAME

The length of the name of the original data set is more than 42.

#### WARNING IN xxxxxx TASK

A warning message or messages were issued from the subtask that is indicated by xxxxxx. xxxxxx is one of the following tasks:

- UNLOAD for Unload task
- RELOAD for Reload task
- IDXBLD for Index Builder task

- PFXRES for Prefix Resolution task
- IMGCPY for Image Copy task

### ERROR IN IMGCPY TASK

An error or errors occurred in the Image Copy task and the task ended with a return code of 8 or larger.

### System action

The Smart Reorg utility continues processing and ends with a return code of 4 or 12.

### User response

If the *reason* is EXTERNAL REFERENCE and no error is found in the reorganization process, perform the post-reorganization processing manually. For details, see “External logical relationships” on page 214.

If the *reason* is LENGTH OF DATA SET NAME and no error is found in the reorganization process, prepare the IDCAMS command stream for name swapping. To do this, refer to the sample stream shown in “Result of Name Swapping report” on page 263. Then, perform the post-reorganization processing manually. For details, see “Post-reorganization processing” on page 212.

If the *reason* is WARNING IN xxxxxx TASK, check the return code and reason code of the corresponding task. If you can ignore the warning issued from the task and no other error is found in the reorganization process, perform the post-reorganization processing manually. For details, see “Post-reorganization processing” on page 212.

If the *reason* is ERROR IN IMGCPY TASK, see the Explanation and Programmer Response of message HPSG0016A that follows this message.

---

**HPSG0333E      ERROR RETURN FROM DSPURX00.  
RETURN CODE IS xx**

### Explanation

An error occurred when the IMS DBRC utility (DSPURX00) was called during the parallel reorganization. The return code from DSPURX00 is xx.

### System action

The Smart Reorg utility ends with a return code of 8.

### User response

Refer to the output from DSPURX00 that is printed in the HPSOUT2 data set.

---

**HPSG0334I      UNABLE TO OBTAIN *intent*  
AUTHORIZATION FOR *ttttttt*  
*yyyyyyyy*; USED BY *zzzzzzz***

### Explanation

This message notifies the operator that a database component whose DBD name or partition name is *yyyyyyyy* needs the indicated authorization. The type of the component is indicated by the string *ttttttt*; the component is

- A database if *ttttttt* is DATABASE
- A HALDB partition if *ttttttt* is PART
- A primary index if *ttttttt* is P-INDEX
- A secondary index if or PSINDEX partition *ttttttt* is S-INDEX

The database, the HALDB partition, or index (*yyyyyyyy*) is being used by an IMS subsystem or a batch job; string *zzzzzzz* shows the name of the subsystem or the batch job. The string *intent* shows the type of authorization required. The *intent* can be EXCLUSIVE or READ-EXCL. If *intent* is EXCLUSIVE, the message shows that the authorization for the database or index *yyyyyyyy* is not prohibited—that is, the DBRC 'PROHIBIT AUTHORIZATION' flag for *yyyyyyyy* is OFF—or another IMS subsystem or a batch job *zzzzzzz* is accessing the database. If *intent* is READ-EXCL, the DBRC 'READ ONLY' flag is OFF for *yyyyyyyy* or another IMS subsystem, or a batch job *zzzzzzz* is accessing the database with the update or exclusive intent.

### System action

If AUTHFAIL=ABORT is specified, the message is followed by message HPSG0335E and the Smart Reorg utility ends with a return code of 8. If AUTHFAIL=WTOR is specified, the message is followed by message HPSG0336A.

### Operator response

See Operator Response for HPSG0335E or HPSG0336A.

---

**HPSG0335E      DBRC AUTHORIZATION  
CONDITION IS NOT SATISFIED**

### Explanation

This message is preceded by one or more HPSG0334I messages, message HPSG0351I, or message HPSG0352I. These messages indicate the failed DBRC authorization request as follows:

- EXCLUSIVE and PROHIBIT AUTHORIZATION indicate that the exclusive authorization is required

and no concurrent access from another IMS subsystem or batch job is allowed.

- READ-EXCL and READ-ONLY indicate that the exclusive authorization is required, but read-only access by other IMS subsystems or batch jobs is allowed.

This message can be issued if the RECON data sets used in the job and those used in online are different.

### System action

The Smart Reorg utility ends with a return code of 8.

### Operator response

First, check if the correct RECON data sets are used for the job. If the database is being used online, issue the following command for the database:

- For READ-EXCL, the /DBD command
- For EXCLUSIVE, the /DBR command

If batch jobs are running, cancel the jobs or wait for the completion of the jobs. If you confirm that the /DBD or /DBD command has been processed successfully on all IMS subsystems that share the database, and no batch job is accessing the database (when EXCLUSIVE) or only the read-only batch jobs are running (when READ-EXCL), rerun the job.

---

**HPSG0336A**      **xxxxxxxx AUTHORIZATION  
REQUIRED REPLY 'RETRY' OR  
'CANCEL'**

### Explanation

This message is preceded by one or more HPSG0334I, HPSG0351I, and HPSG0352I messages. The string xxxxxxxx can be EXCLUSIVE or READ-EXCL. Messages HPSG0334I, HPSG0351I, and HPSG0352I indicate what action is required for which database or index. Message HPSG0336A notify you to wait for completion of the required actions.

This message can be issued if the RECON data sets used in the job and those used online are different.

### System action

The Smart Reorg utility waits for a response from the operator.

### Operator response

Enter one of the following replies: RETRY or CANCEL. If CANCEL is entered, the processing is aborted. RETRY can be abbreviated as R, CANCEL as C.

Before you enter RETRY, you must confirm that the required authorization condition is satisfied. For example, if the database is being used online, issue the following command for the database or index: if xxxxxxxx is READ-EXCL, the /DBD command, or if xxxxxxxx is EXCLUSIVE, the /DBR command. If batch jobs are running, cancel the jobs or wait for the completion of the jobs.

If you reply RETRY, the parallel reorganization job continues and retries to obtain authorization from DBRC. Message HPSG0336A might be reissued if the authorization condition is not satisfied for the database or an index. The number of retries allowed is 10. If the number is reached, message HPSG0339E is issued and the processing is aborted.

If the authorization fails although the authorization condition is satisfied, check if the correct RECON data sets are used for the job.

---

**HPSG0337I**      **'CANCEL' IS ACCEPTED**

### Explanation

The reply 'CANCEL' has been entered for the preceding message HPSG0336A. The DBRC authorization status is not rechecked and the processing is aborted. If CANCEL is abbreviated as C, "C" is shown instead of "CANCEL" in the message text.

### System action

The Smart Reorg utility ends with a return code of 8.

### User response

Refer to message HPSG0334I issued for the job and understand why the required authorization has not been obtained. Resolve the problem, if any, and rerun the job.

---

**HPSG0338I**      **'RETRY' IS ACCEPTED**

### Explanation

The reply 'RETRY' has been entered for the preceding message HPSG0336A. The DBRC authorization status will be rechecked for the database indicated by HPSG0336A. If RETRY is abbreviated as R, "R" is shown instead of "RETRY" in the message text.

### System action

The Smart Reorg utility continues processing.

### User response

None. This message is informational.

---

**HPSG0339E      RETRY COUNT FOR  
STATUS CHECK HAS  
EXPIRED; DATABASE=xxxxxxx  
[PARTITION=yyyyyy]**

### Explanation

Reorganization Manager has checked the DBRC authorization status for the database xxxxxxx or the partition yyyyyy of the HALDB xxxxxxx 10 times, but the authorization required for the parallel reorganization job has not been obtained.

### System action

The Smart Reorg utility ends with a return code of 8.

### User response

Refer to messages HPSG0334I and HPSG0351I (or HPSG0352I) issued for the job to understand why the required authorization has not been obtained. Resolve the problem, if any, and rerun the job.

---

**HPSG0340I      NAME SWAP PROCESSING  
STARTS**

### Explanation

This is an information message that tells you that the name swap processing has started.

### System action

The Smart Reorg utility continues processing.

### User response

None. This message is informational.

---

**HPSG0341I      NAME SWAP PROCESSING  
COMPLETED**

### Explanation

The automated name swapping has been completed successfully for the parallel reorganization job.

### System action

The Smart Reorg utility continues processing.

### User response

Check the result of the name swapping by referring to the Result of the Name Swapping report.

---

**HPSG0342E      ERROR RETURN FROM DSPURXRT.  
RETURN CODE IS xx**

### Explanation

An error occurred when the IMS DBRC utility (DSPURXRT) was called during the parallel reorganization. The return code from DSPURXRT is xx.

### System action

The Smart Reorg utility ends with a return code of 8.

### User response

Refer to the messages printed in the DBRC Notification Processing report.

---

**HPSG0343E      NAME SWAP PROCESSING FAILED**

### Explanation

An error occurred during the name swap processing.

### System action

The Smart Reorg utility ends with a return code of 8.

### User response

See the messages that were issued from the IDCAMS program, and identify the cause of the error. The messages are printed in the Result of Name Swapping report.

---

**HPSG0344E      TOO MANY IMS SUBSYSTEMS**

### Explanation

The Smart Reorg utility detected an internal error. The number of IMS IDs associated with a DBD exceeded 10.

### System action

Reorganization Manager issues a U0344 abend, and the Smart Reorg utility ends with a return code of 16.

### User response

This error is likely an internal system error. Contact IBM Software Support.

---

**HPSG0345I      COMPRTN IS CHANGED IN  
NEW DBD: DBD=dbd\_name,  
SEGM=segmname,ii**

### Explanation

The SEGM COMPRTN parameter is changed in the new DBD, which is specified by the NEWDBD control statement.

## System action

The Smart Reorg utility continues processing. If Unload-task DECOMPRESS=NO is specified, the message is followed by message HPSG0303E and the Smart Reorg utility ends with a return code of 8.

## User response

None. This message is informational.

---

**HPSG0346E DATA SET NOT FOUND: *dsname*  
(DDN=*ddname*)**

## Explanation

An entry for the VSAM or OSAM database data set *dsname* for *ddname* DD was not found in the catalog.

## System action

The Smart Reorg utility ends with a return code of 8.

## User response

Make sure that the data set is defined correctly, and rerun the job.

---

**HPSG0347E INCORRECT DATA SET:  
*ddname,type,dsname***

## Explanation

The database data set *dsname* for *ddname* DD was found in the catalog, however, it is not the type that is defined in the DBD. *type* is one of following types:

### ESDS

VSAM ESDS

### KSDS

VSAM KSDS

### OSAM

OSAM (NON-VSAM)

## System action

The Smart Reorg utility ends with a return code of 8.

## User response

Ensure that the data set is cataloged correctly by issuing the IDCAMS LISTCAT command. Then, rerun the job.

---

**HPSG0348E VSAM COMPONENT NAME IS TOO  
LONG: *comp\_name***

## Explanation

The name of a data component or an index component of a VSAM data set is longer than 42 characters. If NAMESWAP=YES is specified, the component name must be 42 or fewer characters because Smart Reorg utility appends two characters to the name.

## System action

The Smart Reorg utility ends with a return code of 8.

## User response

Make the name shorter or specify NAMESWAP=NO. For more information, see [“NAMESWAP control statement”](#) on page 147.

---

**HPSG0349I DBD CHANGE FOUND IN  
COMPRESSED SEGMENT: SEGM=  
*segmname,ii***

## Explanation

For the indicated compressed segment, either the length of the segment or the length of the sequence key field was changed in the new DBD, which is specified by the NEWDBD control statement.

## System action

The Smart Reorg utility continues processing. If Unload-task DECOMPRESS=NO is specified, the message is followed by message HPSG0303E and the Smart Reorg utility ends with a return code of 8.

## User response

None. This message is informational.

---

**HPSG0350I POST PROCESSING COMPLETED**

## Explanation

The post-reorganization processing has been completed successfully for the parallel reorganization job.

## System action

The Smart Reorg utility continues processing.

## User response

None. This message is informational.

---

**HPSG0351I DBRC 'PROHIBIT  
AUTHORIZATION' FLAG IS NOT**

**ON FOR [DATABASE|P-INDEX|S-INDEX] xxxxxxxx [PART yyyyyyy]**

### Explanation

The DBRC PROHIBIT AUTHORIZATION flag has not been turned on for the database (DATABASE), primary index (P-INDEX), or secondary index (S-INDEX) xxxxxxxx, or for the partition yyyyyyy of the HALDB xxxxxxxx.

### System action

If AUTHFAIL=ABORT, the job ends with return code 8. If AUTHFAIL=WTOR, the message is followed by message HPSG0336A, requesting an operator response.

### User response

Turn on the PROHIBIT AUTHORIZATION flag, either by issuing a global /DBR command or by using the CHANGE.DB command with the NOAUTH parameter.

---

**HPSG0352I DBRC 'READ ONLY' FLAG IS NOT ON FOR [DATABASE|P-INDEX|S-INDEX ] xxxxxxxx [PART yyyyyyy]**

### Explanation

DBSHARE=YES was specified, but the DBRC 'READ ONLY' flag has not been turned on for the database (DATABASE), primary index (P-INDEX), or secondary index (S-INDEX), or for the partition yyyyyyy of the HALDB xxxxxxxx.

CRIC=ALWAYS, CRUNLOAD=ALWAYS, or both are specified, but the DBRC 'READ ONLY' flag has not been turned on for the indicated database, primary index, or the HALDB partition, which does not require reorganization.

### System action

If AUTHFAIL=ABORT, the job ends with return code 8. If AUTHFAIL=WTOR, the message is followed by message HPSG0336A, requesting an operator response.

### User response

Turn on the 'READ ONLY' flag, either by issuing a global /DBD command or by using the CHANGE.DB command with READON parameter.

---

**HPSG0360E INCORRECT REPLY. 'reply' IS NOT ACCEPTED.**

### Explanation

The reply *reply* has been entered for the preceding message HPSG0336A, but it is incorrect. The retry count is incremented by one.

### System action

Processing continues and HPSG0336A is reissued.

### User response

Reply RETRY or CANCEL.

---

**HPSG0361I NOTIFY.REORG DBD(*dbdname*) DDN(*ddname*)**

### Explanation

After image copy processing, the Smart Reorg utility issued a NOTIFY.REORG command to DBRC for the data set that is identified by DD name *ddname*, and the command was processed successfully.

### System action

The Smart Reorg utility continues processing.

### User response

None. This message is informational.

For details about the result of the notification, see the DBRC Notification Processing report.

---

**HPSG0361E NOTIFY.REORG DBD(*dbdname*) DDN(*ddname*)—ERROR (CC=*xx*)**

### Explanation

After image copy processing, an error occurred during the DBRC notification processing. The error occurred when the NOTIFY.REORG command was issued for the data set that is identified by DD name *ddname*. The condition code that is returned from the DBRC utility (DSPURX00) is *xx*.

### System action

The Smart Reorg utility ends with a return code of 8.

## User response

See the messages that are issued from the DBRC utility, and identify the cause of the error. The messages are printed in the DBRC Notification Processing report.

---

**HPSG0362I**      **NOTIFY.UIC DBD(*dbdname*)  
DDN(*ddname*)**

## Explanation

The Smart Reorg utility issued a NOTIFY.UIC command for the data set that is specified by DD name *ddname* after the image copy processing that was specified by the IC=YES control statement has completed. The command was successful.

## System action

The Smart Reorg utility continues processing.

## User response

None. This message is informational.

For details about the result of the notification, see the DBRC Notification Processing report.

---

**HPSG0362E**      **NOTIFY.UIC DBD(*dbdname*)  
DDN(*ddname*)—ERROR (CC=*xx*)**

## Explanation

An error occurred when the Smart Reorg utility issued a NOTIFY.UIC command for the data set that is identified by DD name *ddname* after the image copy processing that was designated by the IC=YES control statement completed. The condition code returned from the DBRC utility (DSPURX00) is *xx*.

## System action

The Smart Reorg utility ends with a return code of 8.

## User response

See the messages that were issued from the DBRC utility, and identify the cause of the error. The messages are printed in the DBRC Notification Processing report.

---

**HPSG0363I**      **NOTIFY.IC DBD(*dbdname*)  
DDN(*ddname*)**

## Explanation

The Smart Reorg utility issued a NOTIFY.IC command for the data set that is specified by DD name *ddname* after the image copy processing that was designated

by the IC=YES control statement has completed. The command was successful.

## System action

The Smart Reorg utility continues processing.

## User response

None. This message is informational.

For details about the result of the notification, see the DBRC Notification Processing report.

---

**HPSG0363E**      **NOTIFY.IC DBD(*dbdname*)  
DDN(*ddname*)—ERROR (CC=*xx*)**

## Explanation

An error occurred when the Smart Reorg utility issued a NOTIFY.IC command for the data set that is identified by DD name *ddname* after the image copy processing that was designated by the IC=YES control statement has completed. The condition code returned from the DBRC utility (DSPURX00) is *xx*.

## System action

The Smart Reorg utility ends with a return code of 8.

## User response

See the messages that were issued from the DBRC utility, and identify the cause of the error. The messages are printed in the DBRC Notification Processing report.

---

**HPSG0364I**      **CHANGE.IC DBD(*dbdname*)  
DDN(*ddname*)**

## Explanation

The Smart Reorg utility issued a CHANGE.IC command for the data set that is identified by DD name *ddname* because an error occurred while the secondary image copy of the data set was being taken. The CHANGE.IC command was processed successfully.

## System action

The Smart Reorg utility continues processing.

## User response

None. This message is informational.

For details about the result of the notification, see the DBRC Notification Processing report.



---

**HPSG0364E**      **CHANGE.IC DBD(*dbdname*)  
DDN(*ddname*)—ERROR (CC=*xx*)**

### Explanation

The Smart Reorg utility issued a CHANGE.IC command for the data set that is identified by DD name *ddname* because an error occurred while the secondary image copy of the data set was being taken. For the CHANGE.IC command, an error was returned with the condition code *xx* from the DBRC utility (DSPURX00).

### System action

The Smart Reorg utility ends with a return code of 8.

### User response

See the messages that were issued from the DBRC utility, and identify the cause of the error. The messages are printed in the DBRC Notification Processing report.

---

**HPSG0370I**      **[DATABASE|P-INDEX] *dbdname*  
WILL BE RELOADED BY USING  
NEW DEFINITION**

### Explanation

The NEWDBD control statement is specified. The Reload task uses the new DBD, for the database *dbdname*, that is stored in the DBD library specified by the NEWDBD control statement. This message is issued also for primary index (P-INDEX) of a HIDAM database.

### System action

Processing continues. If NAMESWAP=YES is specified, message HPSG0371I follows.

### User response

Make sure that the new DBD used is the correct one. For the post-processing required after the job step is ended, see the explanation of HPSG0371I.

---

**HPSG0371I**      **[DATABASE | P-INDEX | S-INDEX]  
*dbdname* REMAINS IN NOAUTH  
STATUS DUE TO DBD CHANGE**

### Explanation

The NEWDBD control statement was specified. The Reload task (and if INDEXBLD=YES or PSINDEXBLD=YES, the Index Builder task) uses the new DBD for database *dbdname*. Reorganization Manager leaves the PROHIBIT AUTHORIZATION flag in the RECON turned on. This message is issued also

for primary index (P-INDEX) and secondary index (S-INDEX) if any is defined for the database. The message is preceded by message HPSG0370I for database *dbdname*.

### System action

Processing continues.

### User response

You must perform some tasks such as running the ACBGEN or updating DBD libraries before you allow the access to the reorganized database. You must run the DBRC utility (DSPURX00) to turn off the flag after you have made an image copy of the database and before using the database.

---

**HPSG0372I**      **SECONDARY INDEX *xxxxxxx*  
MUST BE REORGANIZED OR  
REBUILT**

### Explanation

The database that has been reorganized in the job step has the secondary index *xxxxxxx*, but it has not been reorganized because INDEXBLD=YES was not specified. You must reorganize the secondary index or rebuild it, by using the index building utility such as IMS Index Builder, in a separate job step.

### System action

Processing continues.

### User response

Reorganize the secondary index or rebuild it.

---

**HPSG0373I**      **S-INDEX *sindex* WILL BE REBUILT  
BY USING NEW DEFINITION**

### Explanation

The NEWDBD control statement is specified. The Index Builder task uses the new DBD, for the secondary index *dbdname*, that is stored in the DBD library specified by the NEWDBD control statement.

### System action

Processing continues. If NAMESWAP=YES is specified, message HPSG0371I follows.

### User response

Make sure that the new DBD used is the correct one. For the post-processing required after the job step is ended, see the explanation of HPSG0371I.

---

**HPSG0374W ILDS MUST BE REBUILT****Explanation**

ILDSBLD=NO or ILDSBLD=YES,INITONLY is specified although the database that has been reorganized is a HALDB. Indirect list entries (ILEs) must be created for each partition.

**System action**

The Smart Reorg utility continues processing and ends with return code of 4.

**User response**

Complete one of the following actions:

- Use the IMS HALDB Index/ILDS Rebuild Utility (DFSPREC0) to rebuild the indirect list data sets (ILDSs). To do so, in a separate job step or in a separate job, code JCL statements for the IMS HALDB Index/ILDS Rebuild Utility to rebuild the ILDS for each HALDB partition that was reorganized by the Smart Reorg utility job.
- Use the Smart Reorg utility to rebuild the ILDSs. To do so, specify ILDSBLD=YES and rerun the job.
- If the HALDB has no logical relationships and you prefer to rebuild PSINDEX rather than rebuilding ILDS, specify PSINDEXBLD=YES and rerun the job.

---

**HPSG0375W NO SEGMENT WAS RELOADED INTO PARTITION xxxxxxx****Explanation**

Reorganization of the HALDB partition xxxxxxx was requested and the original database data set or data sets of the partition was not empty, but no segment has been reloaded into the partition. If a user exit routine was used for the Unload task or the Reload task and all segments were specified not to be unloaded or reloaded, this message can be issued.

**System action**

The Smart Reorg utility continues processing.

**User response**

If you used a user exit routine for the Unload task or the Reload task and you specified that all segments were not to be unloaded or reloaded intentionally, you can ignore the message. If you did not use any such user exit routine, the error is probably in IMS Database Reorganization Expert. In that case, recover the original database and contact IBM Software Support.

---

**HPSG0376I IMAGE COPY NEEDED FOR DBDNAME=*dbdname* DDNAME=*ddname*****Explanation**

An image copy must be taken before applications are scheduled to use the database data set specified by *dbdname* and *ddname*.

**System action**

None.

**User response**

Schedule an image copy operation before applications are scheduled to use the specified database data set. If the database has no external logical relationships, you can specify IC=YES to take image copies.

---

**HPSG0377I PREFIX RESOLUTION AND UPDATE ARE NEEDED FOR DBD=*dbdname*****Explanation**

The database *dbdname* has logical relationships. You have to run the prefix resolution and update utilities after this IMS Database Reorganization Expert job.

**User response**

Run the prefix resolution and the prefix update utilities. If the database has no external logical relationships, specify PREFIXRES=YES control statement to activate the prefix resolution and the update function in the IMS Database Reorganization Expert step.

---

**HPSG0378I PREFIX RESOLUTION AND UPDATE ARE NOT NEEDED FOR DBD=*dbdname*****Explanation**

The database *dbdname* has logical relationships, which do not need to run Prefix Resolution and Update utilities after the Smart Reorg utility job step. For the details of the reason, see [“Logical relationships that do not require Prefix Resolution and Update”](#) on page 110. You can specify IC=YES and either ICTYPE=A or B to take image copies in the Smart Reorg utility job step for this database.

**System action**

Processing continues.

## User response

None. This message is informational.

---

**HPSG0379W PREFIX RESOLUTION AND UPDATE ARE NEEDED FOR DBD=*dbdname***

## Explanation

PREFIXRES=YES is ignored because the database *dbdname* has external logical relationships. Prefix resolution and update are required after the Smart Reorg utility job step.

## System action

Processing continues.

## User response

Run IMS Prefix Resolution and Update utilities after the Smart Reorg utility job step.

---

**HPSG0380E DEACTIVATE DYNALLOC FOR [INPUT DB|OUTPUT DB|S-INDEX] OR REMOVE *ddname* DD FOR *dbdname***

## Explanation

The dynamic allocation for the input disorganized database, the output shadow database, or the output secondary indexes is designated by a DYNALLOC control statement. But the *ddname* DD statement for the database or index *dbdname* is coded in the JCL stream. Therefore, the dynamic allocation processing fails.

## System action

Message HPSG0310E follows, and the Smart Reorg utility ends with a return code of 8.

## User response

If you do not want to allocate the DD *ddname* dynamically, specify NO for the corresponding sub parameter of the first parameter of DYNALLOC control statement. Otherwise, remove the *ddname* DD statement. For details of DYNALLOC control statement, see “DYNALLOC control statement” on page 136.

---

**HPSG0381E DATA SET SPECIFIED FOR DDNAME *ddname* (DBD=*dbdname*) IS NOT REGISTERED TO DBRC**

## Explanation

The data set name specified, by a JCL DD statement or a DFSMDA member, for the DD name *ddname* for the database, primary index, or secondary index *dbdname* is not the same as the one that is registered to DBRC.

## System action

The Smart Reorg utility ends with a reason code of 8.

## User response

Check whether the correct RECON data sets and the correct data sets are specified by referring to the Data Set Information report. Correct the error, and rerun the job.

If you want to specify a different data set name for the DD name *ddname* of the database, primary index, or secondary index from what is registered in RECONS, you can rerun the job specifying DBRC=N in the EXEC parameter. However, if you cannot specify DBRC=N in the EXEC parameter because your IMS system has been generated as DBRC=FORCE, you can run the job using the dummy RECONS. The data set name for the DD name *ddname* of the database, primary index, or secondary index that you want to specify must be registered in the dummy RECONS.

---

**HPSG0382E DATA SET (DDNAME *ddname*) FOR [DATABASE|P-INDEX|S-INDEX] *dbdname* IS NOT REGISTERED TO DBRC**

## Explanation

The database (DATABASE), primary index (P-INDEX), or secondary index (S-INDEX) *dbdname* is registered to DBRC, but the data set whose DD name is *ddname* is not registered. All data sets for *dbdname* must be registered to DBRC.

## System action

The Smart Reorg utility ends with a reason code of 8.

## User response

Check whether the correct RECON data sets and the correct DBD library are used by referring to the Data Set Information report. Correct the error, and rerun the job.

---

**HPSG0383E [DATABASE|P-INDEX|S-INDEX] *dbdname* IS NOT REGISTERED TO DBRC ALTHOUGH IT IS FORCED**

## Explanation

The *dbdname* of the database (DATABASE), the primary index (P-INDEX), or the secondary index (S-INDEX) is not registered to DBRC although the RECON data sets have been initialized with the FORCER option.

## System action

The Smart Reorg utility ends with a reason code of 8.

## User response

Check whether the correct RECON data sets are used by referring to the Data Set Information report. Correct the error, and rerun the job.

---

**HPSG0384E      OUTPUT DATA SET SPECIFIED  
FOR S-INDEX *dbdname* IS SAME  
AS THE CURRENT**

## Explanation

The data set in which the secondary index *dbdname* is specified to be rebuilt is the same as the current index data set although INDEXBLD=YES,NEW or PSINDEXBLD=YES,NEW is specified.

## System action

The Smart Reorg utility ends with a reason code of 8.

## User response

Specify a secondary index data set other than the current one, or specify INDEXBLD=YES,CURRENT or PSINDEXBLD=YES,CURRENT.

---

**HPSG0385E      OUTPUT DATA SET  
(DDNAME=*ddname*) FOR  
[DATABASE | P-INDEX | S-INDEX]  
*dbdname* IS NOT EMPTY**

## Explanation

The data set assigned to the DD name *ddname* is not empty. The *ddname* is one of the DD names that are used to specify the output data sets. String *dbdname* indicates the type of the data set identified by *ddname*. The type is one of the following:

- A primary database or a HALDB partition (DATABASE)
- The primary index (P-INDEX)
- A secondary index (S-INDEX)

## System action

The Smart Reorg utility ends with a reason code of 8.

## User response

Check whether the correct data set is specified for the DD name. You can identify which data set was tried to be used for the DD name, by referring to the Data Set Information report.

---

**HPSG0386E      DATABASE *dbdname* IS NOT  
REGISTERED TO DBRC ALTHOUGH  
IT IS HALDB**

## Explanation

The database *dbdname* is a HALDB, but it is not registered to DBRC.

## System action

The Smart Reorg utility ends with a reason code of 8.

## User response

Refer to the Data Set Information report to check whether the correct RECON data sets are used. Correct the error and rerun the job.

---

**HPSG0387E      DATABASE xxxxxxxx IS  
REGISTERED AS TYPE= HALDB|  
IMS**

## Explanation

One of the following problems is encountered for the database xxxxxxxx:

- It is not a HALDB, but it is registered to DBRC as TYPE=HALDB.
- It is a HALDB, but it is registered to DBRC as TYPE=IMS.

## System action

The Smart Reorg utility ends with a return code of 8.

## User response

Check whether the database was registered to DBRC correctly and the correct DBD was used.

---

**HPSG0388E      SHADOW ILDS OF ONE OR MORE  
PARTITIONS NOT SPECIFIED OR  
NOT EXIST**

## Explanation

This message is issued when either of the following cases applies:

- Shadow ILDS of one or more partitions are not specified in the JCL stream.
- Shadow ILDS of one or more partitions do not exist.

## System action

The Smart Reorg utility ends with a return code of 8.

## User response

Create shadow ILDS for each partition to be reorganized. If the dynamic allocation of the shadow data sets is not requested, you must code the DD statement for shadow ILDS for each partition. If no ILE records are created for the database, you do not need to create a shadow ILDS. If so, either specify ILDSBLD=NO or delete all the shadow ILDSs that exist for the database.

---

**HPSG0389E** [ORIGINAL|NEW] DBD *dbdname*  
IS REUSABLE

## Explanation

The NEWDBD control statement is specified, but the original or the new DBD *dbdname* has a reusable attribute. If one of the original and new DBDs are reusable, the Smart Reorg utility cannot process the DBD change correctly. The original and new DBDs for the primary database, the HIDAM primary index, and (partitioned or non-partitioned) secondary indexes for the database must be generated as non-reusable modules when you change DBDs by coding the NEWDBD control statement.

## System action

The Smart Reorg utility ends with a return code of 8.

## User response

If you use the IBM IMS standard DBDGEN procedure, a DBD is generated as a non-reusable module. The Smart Reorg utility expects that both the original and new DBDs are non-reusable so that the DBDs that have the same name can be loaded in separate addresses. Regenerate the old and new DBDs before running the Smart Reorg utility, or use the IPR Unload utility and the IPR Reload utility sequentially to unload the database with the original DBD and to reload the database with the new DBD in separated job steps.

---

**HPSG0391E** UNSUPPORTED TYPE OF  
SECONDARY INDEX *dbdname* -  
*reason*

## Explanation

INDEXBLD=YES was specified for the job, but the secondary index *dbdname* is defined with an unsupported option.

### *reason*

#### Description

#### NON-UNIQUE KEYS

The secondary index contains non-unique keys.

#### SHARED

The secondary index is a shared index.

#### DOSCOMP

The secondary index is a DOS-compatible index.

## System action

The Smart Reorg utility ends with a return code of 8.

## User response

Remove the INDEXBLD control statement, and rerun the job.

---

**HPSG0392E** RECON VERSION IS NOT FOUND

## Explanation

The Smart Reorg utility failed to obtain the IMS version that is defined in RECON.

## System action

Reorganization Manager issues a U0392 abend, and the Smart Reorg utility ends with a return code of 16.

## User response

This error is likely an internal system error. Contact IBM Software Support.

---

**HPSG0393E** USID ERROR: 2147483647

## Explanation

The Smart Reorg utility detected an internal error. The USID number exceeded 2147483647.

## System action

Reorganization Manager issues a U0393 abend, and the Smart Reorg utility ends with a return code of 16.

## User response

This error is likely an internal system error. Contact IBM Software Support.

---

**HPSG0394E**      **HPSGIRM FAILED:**  
**FUNC=xxxxxxxxxxxxxx, RC=xx,**  
**RSN=yyyyyyyyy-zzzzzzzz**

## Explanation

The Smart Reorg utility detected an internal error in the HPSGIRM macro.

## System action

Reorganization Manager issues a U0394 abend, and the Smart Reorg utility ends with a return code of 16.

## User response

This error is likely an internal system error. Contact IBM Software Support.

---

**HPSG0395E**      **DYNALLOC SERVICE**  
**FAILED: FUNC=funcname**  
**DDNAME=ddname RC=yy**  
**RSN=zzzz**

## Explanation

An internal error occurred in the dynamic allocation service of IMS Database Reorganization Expert. Keyword *funcname* is one of INIT, ALLOC, SYSOUT, UNALLOC, CONCATI, or TERM.

## System action

The Smart Reorg utility task or the subtask that issued the dynamic allocation request abends with a completion code of U0395, and the Smart Reorg utility job step ends with a return code of 16.

## User response

This error is likely an internal system error. Keep the dump produced at the time of error, and contact IBM Software Support.

---

**HPSG0396E**      **HALDB VSAM CLUSTER MUST**  
**BE DEFINED AS REUSABLE;**  
**DDN=ddname**

## Explanation

The VSAM cluster for the HALDB data set, which is specified on the DD statement *ddname*, must be defined with the REUSE parameter.

## System action

The Smart Reorg utility ends with a return code of 8.

## User response

Specify the REUSE parameter when you allocate the space for the shadow data set by using the DEFINE CLUSTER command.

---

**HPSG0397E**      **S-INDEX DATA SET NAME IS NOT**  
**SUFFIXED: DDNAME=ddname**

## Explanation

The data set name specified for the DDNAME *ddname* is not suffixed. The cluster name of the shadow secondary index must be the name of the original secondary index plus a suffix if SINDEXSUF=YES is specified and the following conditions are met:

- DBRC is inactive
- DYNALLOC=(xxx,xxx,NO) is specified
- INDEXBLD=YES,NEW is specified

In other words, SINDEXSUF=YES is specified under these conditions, the cluster name of the original secondary index is assumed to be the cluster name of the shadow secondary index without the last qualifier.

## System action

The Smart Reorg utility ends with a return code of 8.

## User response

First, check if the cluster name specified on the DD statement for *ddname* is correct. If you want to produce the command stream for the name swapping of secondary indexes, change the cluster name of the shadow secondary index so that the cluster name of the shadow secondary index will be the cluster name of the original secondary index with a last qualifier. If you do not need to produce the command stream for the name swapping of secondary indexes, remove the SINDEXSUF=YES control statement.

---

**HPSG0398I**      **HPSGAMSA DATA SET IS USED**  
**FOR ALLOCATING SHADOW SPACE**

## Explanation

The IDCAMS commands that are specified in the HPSGAMSA data set are used by the IDCAMS program to delete and define the shadow data sets.

## System action

The Smart Reorg utility continues processing.

## User response

None. This message is informational.

---

**HPSG0399I      AUTOMATIC SHADOW SPACE  
ALLOCATION IS ATTEMPTED**

## Explanation

The commands to delete and allocate the DASD space for the shadow data sets are generated and issued automatically. The result of this processing is shown in the Result of Shadow Space Allocation report.

## System action

The Smart Reorg utility continues processing.

## User response

None. This message is informational.

---

**HPSG0400E      SHADOW SPACE FOR  
DDNAME=*ddname* CANNOT BE  
ALLOCATED (*reason*)**

## Explanation

The Smart Reorg utility does not support to generate the command to delete and allocate the data set indicated by *ddname* because one of the following reasons.

### Reason

#### Meaning

#### **NON-SMS MUL-VOL OSAM**

The original is a multi-volume OSAM data set on non-SMS managed volumes.

#### **NO MODEL S-IDX**

This secondary index is original or shadow whose original data set is not found.

## System action

The Smart Reorg utility ends with a return code of 8.

## User response

Specify the IDCAMS commands for all shadow data sets in the HPSGAMSA data set.

---

**HPSG0401E      ONLINE REORG ACTIVE  
FOR PARTITION=*pppppppp*  
(DBD=*dddddddd*)**

## Explanation

The online reorganization (OLR) cursor of partition *pppppppp* of HALDB *dddddddd* is active. Parallel

reorganization is not supported for partitions whose OLR cursors are active.

## System action

The Smart Reorg utility ends with a return code of 8.

## User response

Complete the online reorganization for the partition specified by the message before you run the Smart Reorg utility job. If you want to run the Smart Reorg utility job for multiple partitions, you need to check that the OLR cursors for those partitions are not active.

---

**HPSG0402I      DYNAMIC ALLOCATION  
COMPLETED SUCCESSFULLY**

## Explanation

The dynamic allocation for the OSAM shadow data set shown in the Result of Shadow Space Allocation report completed successfully. The shadow data set has been cataloged.

## System action

The Smart Reorg utility continues processing.

## User response

None. This message is informational.

---

**HPSG0403I      INPUT FOR REORGANIZATION IS  
AN UNLOAD DATASET**

## Explanation

The reorganization processing uses the unload data set specified in the DFSUINPT data set, instead of unloading database data sets. In this processing, the shadow data sets are not used and the segments are reloaded to the original data sets directly.

## System action

The Smart Reorg utility continues processing.

## User response

None. This message is informational.

---

**HPSG0404E      AUTHORIZATION FAILURE  
OCCURRED IN  
DBDNAME=*dbdname***

## Explanation

The Smart Reorg utility received an error return code from the IMS authorization module DFSDBAU0 for database *dbdname*.

## System action

The Smart Reorg utility ends with a return code of 8.

## User response

Make sure that the database is authorized before reorganization.

---

**HPSG0405I HPIO IS NOT USED BECAUSE AT LEAST ONE LIBRARY IS NOT AUTHORIZED**

## Explanation

High Performance I/O Driver (HPIO) is not used in subtasks because at least one library is not APF-authorized.

## System action

The Smart Reorg utility continues processing.

## User response

If you want to use HPIO, you must APF-authorize all libraries in the STEPLIB DD concatenation.

---

**HPSG0406I HPIO=[YES|NO] IS USED**

## Explanation

HPIO=YES or NO is used in the subtasks of Smart Reorg utility. This overrides the HPIO control statement in each subtask.

## System action

The Smart Reorg utility continues processing.

## User response

If you want HPIO=YES, you must APF-authorize all libraries in the STEPLIB DD concatenation.

---

**HPSG0407E RECON MINIMUM VERSION IS NOT FOUND**

## Explanation

The Smart Reorg utility failed to obtain the RECON MINIMUM version that is defined in RECON.

## System action

Reorganization Manager issues a U0407 abend, and the Smart Reorg utility ends with a return code of 16.

## User response

This error is likely an internal system error. Contact IBM Software Support.

---

**HPSG0408I INCORRECT MUL-VOL OSAM DATA SET: DSN=*dsname***

## Explanation

A primary extent must be allocated on each volume of multi-volume OSAM data set, however, it was not allocated on the second volume of the data set *dsname*.

## System action

The Smart Reorg utility continues its processing.

## User response

If the volumes are SMS-managed, the SMS storage class should have the guaranteed space attribute as described in *IMS Database Administration*.

**Important:** Without the guaranteed space attribute, only the first volume will get a primary extent. The other volumes will get secondary extents.

If the allocation occurs during the load mode, OSAM will use only the primary space. During the update mode, the last volume that is used during load will have any remaining primary space used, plus any secondary space allocation. This means that any attempt to load or copy beyond a first volume will fail. If the attempt to update the reorganized database fits into the primary space of the first volume, no further consideration is needed. In this case, the Smart Reorg utility job can continue with the limited space, but there might be a failure later.

The Smart Reorg utility issues the HPSG0408I message, which means that the Guaranteed Space=YES setting is recommended to prevent an I/O failure in the update mode. The message is informational because there is the potential for an I/O failure.

---

**HPSG0409W SOME SEGMENTS WERE NOT RELOADED**

## Explanation

The Smart Reorg utility received the reason code which means some segment occurrences were not



reloaded due to an error or a warning in the Reload task.

### System action

The Smart Reorg utility does not make the reorganized database available because user attention is needed.

### User response

See the message issued by the Reload task, such as HPSR0006W and HPSR0032W.

---

<b>HPSG0410I</b>	<b>DBRC PROCESSING FOR RESTORING AUTHORIZATION FLAGS STARTS</b>
------------------	---

### Explanation

This is an information message that tells you that the DBRC processing for restoring authorization flags has started. In this process, the READ ONLY flag or the PROHIBIT AUTHORIZATION flag is restored.

### System action

The Smart Reorg utility continues processing.

### User response

None. This message is informational.

---

<b>HPSG0411I</b>	<b>DBRC PROCESSING FOR RESTORING AUTHORIZATION FLAGS COMPLETED</b>
------------------	--

### Explanation

The DBRC processing for restoring authorization flags has been completed successfully.

### System action

The Smart Reorg utility continues processing.

### User response

None. This message is informational.

---

<b>HPSG0412E</b>	<b>DBRC PROCESSING FOR RESTORING AUTHORIZATION FLAGS FAILED</b>
------------------	---

### Explanation

The DBRC processing for restoring authorization flags has been attempted, however, failed on one or more DBRC commands.

### System action

The Smart Reorg utility continues processing.

### User response

Check the condition code returned from DSPURX00 in the DBRC Processing for the Restoring Authorization Flags report and issue the CHANGE.DB command to restore the authorization flags.

---

<b>HPSG0413W</b>	<b>DBRC PROCESSING FOR RESTORING AUTHORIZATION FLAGS IS SKIPPED</b>
------------------	---

### Explanation

The Smart Reorg utility skips the DBRC processing to restore authorization flags because the post-reorganization processing failed and NAMESWAPFAIL=BACKOUT was not specified.

### System action

The Smart Reorg utility continues processing.

### User response

Issue the CHANGE.DB command to restore the authorization flags. If NAMESWAPFAIL=BACKOUT is specified, the flags are restored automatically.

---

<b>HPSG0420A</b>	<b>ERROR IN NAME SWAP. REPLY 'RETRY', 'CANCEL' OR 'BACKOUT'</b>
------------------	---

### Explanation

NAMESWAPFAIL=WTOR was specified and an error occurred in the name swap processing. The operator's reply is required.

### System action

The Smart Reorg utility waits for a response from the operator.

### Operator response

Enter one of the following replies: RETRY, CANCEL, or BACKOUT. The meanings of the replies are described in the “NAMESWAPFAIL control statement” on page 148. Before you enter RETRY, you must confirm the reason of the error and take appropriate operation to avoid another error. The number of retries allowed is 10.

---

<b>HPSG0421E</b>	<b>INCORRECT REPLY. 'reply' IS NOT ACCEPTED.</b>
------------------	--

## Explanation

The reply *reply* has been entered for the preceding message HPSG0420A, but it is incorrect. The retry count is incremented by one.

## System action

Processing continues and HPSG0420A is reissued.

## User response

Reply with RETRY, CANCEL, or BACKOUT.

---

**HPSG0422I      'CANCEL' IS ACCEPTED**

## Explanation

The reply 'CANCEL' has been entered for the preceding message HPSG0420A. If CANCEL is abbreviated as C, "C" is shown instead of "CANCEL" in the message text. The name swap processing is terminated without the automated backout processing.

## System action

The Smart Reorg utility continues processing.

## User response

None. This message is informational.

---

**HPSG0423I      'RETRY' IS ACCEPTED**

## Explanation

The reply 'RETRY' has been entered for the preceding message HPSG0420A. If RETRY is abbreviated as R, "R" is shown instead of "RETRY" in the message text. The name swap processing will be retried.

## System action

The Smart Reorg utility continues processing.

## User response

None. This message is informational.

---

**HPSG0424I      'BACKOUT' IS ACCEPTED**

## Explanation

The reply 'BACKOUT' has been entered for the preceding message HPSG0420A. If BACKOUT is abbreviated as B, "B" is shown instead of "BACKOUT" in the message text. The automated backout processing will be started.

## System action

The Smart Reorg utility continues processing.

## User response

None. This message is informational.

---

**HPSG0425E      RETRY COUNT IN NAME SWAP  
PROCESSING HAS EXPIRED**

## Explanation

The count of the replies as 'RETRY' reached the limit, 10. The Smart Reorg utility terminates the name swap processing.

## System action

The Smart Reorg utility ends with a return code of 8.

## User response

See the following messages.

---

**HPSG0426I      DATA SET IN USE: *dsname***

## Explanation

During the name swap processing, the IDCAMS program returns the error with the IDC3028I message because the data set *dsname* is in use by another job.

## System action

The Smart Reorg utility continues processing.

## User response

Identify the job by the following HPSG0427I message.

---

**HPSG0427I      *system-name job-name* IS USING  
OR WAITING: *dsname***

## Explanation

The job *job-name* on the system *system-name* was requested to make access to the data set *dsname*.

## System action

The Smart Reorg utility continues processing.

## User response

To retry the IDCAMS command, wait for the completion of the job or cancel the job.

---

**HPSG0428I      DUPLICATE DS NAME: *dsname***

## Explanation

During the name swap processing, the IDCAMS program returned the error with the IDC3013I message because the new data set name *dsname* exists.

## System action

The Smart Reorg utility continues processing.

## User response

To retry the IDCAMS command, rename or delete the existing data set.

---

**HPSG0430I      BACKOUT PROCESSING FOR  
                  NAMESWAP ERROR STARTS**

## Explanation

This is an information message that tells you that the automated backout processing for the name swap error has started. In this process, the data set names are restored to the names before starting the name swap processing.

## System action

The Smart Reorg utility continues processing.

## User response

None. This message is informational.

---

**HPSG0431I      BACKOUT PROCESSING FOR  
                  NAMESWAP ERROR COMPLETED**

## Explanation

The automated backout processing for the name swap error has completed successfully.

## System action

The Smart Reorg utility continues processing.

## User response

None. This message is informational.

---

**HPSG0432E      BACKOUT PROCESSING FOR  
                  NAMESWAP ERROR FAILED**

## Explanation

The automated backout processing for the name swap error has failed.

## System action

The Smart Reorg utility ends with a return code of 8.

## User response

See the messages that were issued from the IDCAMS program, and identify the cause of the error. The messages are printed in the Result of Name Swapping report.

---

**HPSG0433I      BACKOUT PROCESSING FOR  
                  NAMESWAP ERROR IS NOT  
                  NEEDED**

## Explanation

The automated backout processing for the name swap error is requested, but the processing is not needed because there is no database data set to be succeeded in name swap.

## System action

The Smart Reorg utility continues processing.

## User response

None. This message is informational.

---

**HPSG0440I      *report\_name* IS PRODUCED IN  
                  *ddname* DATA SET**

## Explanation

For the manual processing, the Smart Reorg utility produces the command stream in the *ddname* data set. *report\_name* can be one of the following texts:

- IDCAMS COMMAND STREAM
- DBRC COMMAND STREAM

## System action

The Smart Reorg utility continues processing.

## User response

Run the command stream after the Smart Reorg utility job.

---

**HPSG0441I      MANUAL BACKOUT PROCESSING  
                  FOR NAMESWAP ERROR IS  
                  REQUIRED**

## Explanation

The Smart Reorg utility did not run the automated backout processing for the name swap error. You must run the processing manually.

## System action

The Smart Reorg utility continues processing.

## User response

Run the backout processing manually by using the IDCAMS command stream produced in the HPSGSWAP data set. The same command stream is printed in the IDCAMS Command Stream for Recovery from Name Swap Error report.

---

**HPSG0451W DELETION OF OLD DATA SET  
FAILED**

## Explanation

An error occurred while deleting the old data sets.

## System action

The Smart Reorg utility continues processing and ends with a return code of 4.

## User response

See the messages that were issued from the IDCAMS program, and identify the cause of the error. The messages are printed in the Result of Old Data Sets Deletion report.

---

**HPSG0452E ALLOCATING SHADOW SPACE  
FAILED**

## Explanation

An error occurred while the spaces for the shadow data sets have being allocated.

## System action

The Smart Reorg utility ends with a return code of 8.

## User response

See the messages that were issued from the IDCAMS program, and identify the cause of the error. The messages are printed in the Result of Shadow Space Allocation report. If the IKJ56220I message is issued, specify the DYNAMNBR parameter on the EXEC statement for Smart Reorg utility.

---

**HPSG0453E REORG# UPDATE FAILED FOR  
PARTITION *partition***

## Explanation

An error occurred while updating the HALDB partition reorganization number that is stored in the RECON data set.

## System action

The Smart Reorg utility ends with a return code of 8.

## User response

This error is likely an internal system error. Contact IBM Software Support.

---

**HPSG0454E COPYING PSINDEX RECORDS  
FAILED**

## Explanation

The copy process failed while processing the PSINDEX.

## System action

The Smart Reorg utility ends with a return code of 8.

## User response

See the messages printed in the Result of PSINDEX Copy report.

---

**HPSG0455E VSAM ERROR: *func*  
DDNAME=*ddname*, RC=*rc*,  
RSN=*rsn***

## Explanation

An error occurred while processing the VSAM data set. *func* is OPEN1, OPEN2, GET, PUT, or ERASE.

## System action

The Smart Reorg utility ends with a return code of 8.

## User response

See *z/OS DFSMS Macro Instructions for Data Sets* for the meaning of the reason code. For an OPEN error, the reason code shows the value in the ACBERFLG field. For a GET, PUT, or ERASE error, the reason code shows the value in the RPLERRCD field.

---

**HPSG0456W UNABLE TO ISSUE /STA BECAUSE  
REORGANIZATION IS NEEDED**

## Explanation

The /START DB command is not issued although STARTDB=YES is specified. The Conditional

Reorganization Support Service (CRSS) determined that the database needs to be reorganized, but the database is not reorganized yet because UNLOADONLY=YES is specified.

### System action

The Smart Reorg utility ends with a return code of 4.

### User response

Run a database reorganization after this job step.

---

**HPSG0457I DDEFPS2 DATA SET IS USED FOR ALLOCATING SHADOW SPACE**

### Explanation

The IDCAMS commands that are specified in the DDEFPS2 data set are used by the IDCAMS program to delete and define the shadow data sets.

### System action

The Smart Reorg utility continues processing.

### User response

None. This message is informational.

---

**HPSG0458I MEMBER FOR DD=*ddname* NOT FOUND IN DDEFPS2 DATA SET**

### Explanation

The data set specified for the DDEFPS2 DD statement does not contain a member with the indicated name.

### System action

The Smart Reorg utility generates IDCAMS commands to define or allocate the shadow data set of the indicated database data set.

### User response

None. This message is informational.

---

**HPSG0459W RENAMING OF OLD DATA SET FAILED**

### Explanation

Because DISPOLDDS=NEWSHADOW is specified, the Smart Reorg utility attempted to rename the data set name from the temporary data set name to the shadow data set name but it failed.

### System action

The Smart Reorg utility continues processing and ends with a return code of 4.

### User response

See the messages that were issued from the IDCAMS program and identify the cause of the error. The messages are printed in the Result of Renaming Old Data Sets report.

---

**HPSG0460E KEYLABELS ARE DIFFERENT BETWEEN RACF DATA SET PROFILE AND SHADOW DBDS (*ddname*)**

### Explanation

Shadow database data sets are present. The key label in the RACF data set profile is different from the key label assigned to the shadow database data set (DD name: *ddname*).

### System action

The Smart Reorg utility ends with a return code of 8.

### User response

Either re-allocate the shadow database data set so that the key label in the RACF data set profile is assigned to the shadow data set, or specify SPACEALLOC=YES,FORCE control statement on the HPSIN DD statement.

---

**HPSG0701I IMGCPY FUNCTION ENDED, HIGHEST RETURN CODE IS 000**

### Explanation

The Image Copy task ended with a decimal return code of 0.

### System action

The Image Copy task ends successfully.

### User response

None. This message is informational.

---

**HPSG0701W IMGCPY FUNCTION ENDED, HIGHEST RETURN CODE IS 004**

### Explanation

The Image Copy task ended with a decimal return code of 004 and with a warning message. For the

reason of the warning, see the preceding FABJ messages that were issued by IMS HP Image Copy.

### System action

The Image Copy task ends with a warning message. The Smart Reorg utility continues processing.

### User response

Check the meaning of the FABJ messages in the *IMS High Performance Image Copy User's Guide*.

---

**HPSG0701E      IMGCPY FUNCTION ENDED,  
                  HIGHEST RETURN CODE IS xxx**

### Explanation

The Image Copy task ended with a decimal return code of xxx because one or more errors occurred. For the reason of the error, see the preceding FABJ messages that were issued by IMS HP Image Copy.

### System action

Other subtasks that are running concurrently with the Image Copy task are forced to end. The post-reorganization processing is not done even if NAMESWAP=YES is specified.

### User response

Check the meaning of the FABJ messages in the *IMS High Performance Image Copy User's Guide*.

---

**HPSG0801I      PFXRES FUNCTION ENDED,  
                  HIGHEST RETURN CODE IS 000**

### Explanation

The Prefix Resolution task ended with a decimal return code of 0.

### System action

The Prefix Resolution task ends normally.

### User response

None. This message is informational.

---

**HPSG0801W      PFXRES FUNCTION ENDED,  
                  HIGHEST RETURN CODE IS 004**

### Explanation

The Prefix Resolution task ended with a decimal return code of 004 and with a warning message. For

the reason of the warning, see the preceding FABY message that was issued by IMS HP Prefix Resolution.

### System action

The Prefix Resolution task ends with a warning message. The Smart Reorg utility continues processing.

### User response

Check the meaning of the return code and the FABY messages in the *IMS High Performance Prefix Resolution User's Guide*.

---

**HPSG0801E      PFXRES FUNCTION ENDED,  
                  HIGHEST RETURN CODE IS xxx**

### Explanation

The Prefix Resolution task ended with a decimal return code of xxx and with an error message. For the reason of the error, see the *IMS High Performance Prefix Resolution User's Guide*.

### System action

Other subtasks that are running concurrently with the Prefix Resolution task are forced to end. The post-reorganization processing is not done even if NAMESWAP=YES is specified.

### User response

Check the meaning of the return code and the FABY messages in the *IMS High Performance Prefix Resolution User's Guide*.

---

**HPSG0901I      IDXBLD FUNCTION ENDED,  
                  HIGHEST RETURN CODE IS 000**

### Explanation

The Index Builder task ended with a decimal return code of 0.

### System action

The Index Builder task ends normally.

### User response

None. This message is informational.

---

**HPSG0901E      IDXBLD FUNCTION ENDED,  
                  HIGHEST RETURN CODE IS xxx**

## Explanation

The Index Builder task ended with a decimal return code of xxx. For the meaning of each return code, see the *IMS Index Builder User's Guide*.

## System action

The Index Builder task ends.

## User response

Check the meaning of the return code and the IIU messages issued from the Index Builder task.

---

<b>HPSG2000I</b>	<b>PIPE SERVICE INITIALIZATION SUCCESSFUL (IPRPIPE V.nn.nn.n)</b>
------------------	---

## Explanation

IPRPIPE service is initialized successfully. The string V.nn.nn.n indicates the internal version ID of IPRPIPE.

## System action

The processing continues.

## User response

None. This message is informational.

---

<b>HPSG2001E</b>	<b>PIPE SERVICE ['INIT' 'TERM'] ERROR; REASON=xxxxxxx</b>
------------------	---

## Explanation

An error occurred while the IPRPIPE service was being initialized or terminated. Reason code xxxxxxxx shows the reason of the error.

## System action

IPRPIPE returns a return code of 8.

## User response

Contact IBM Software Support.

---

<b>HPSG2002E</b>	<b>ERROR IN ALLOCATING PIPE ppppppppppppppppp; REASON=xyyyyyzz-sssssss</b>
------------------	--

## Explanation

An error occurred while the pipe ppppppppppppppppp was being allocated. Reason code xyyyyyzz-sssssss shows the reason of the error.

## System action

IPRPIPE returns a return code of 8.

## User response

Contact IBM Software Support.

---

<b>HPSG2003E</b>	<b>ERROR IN DEALLOCATING PIPE ppppppppppppppppp; REASON=xyyyyyyy-aaaaaaa- bbbbbbb</b>
------------------	---

## Explanation

An error occurred while the pipe ppppppppppppppppp was being deallocated. Reason code xyyyyyzz-aaaaaaa-bbbbbbbb shows the reason of the error.

## System action

IPRPIPE returns a return code of 8.

## User response

Contact IBM Software Support.

---

<b>HPSG2004E</b>	<b>TIME-OUT IN tttttt OF PIPE ppppppppppppppppp; REASON=rrrrrrrr</b>
------------------	--

## Explanation

Timeout occurred while the writer or reader task, which is indicated by tttttt, of the pipe ppppppppppppppppp was waiting for the pipe. Reason code rrrrrrrr shows the reason of the error. For the meaning of the reason code, see the table of reason flags in Explanation of message HPSG2005E.

## System action

Message HPSG2006E follows and the task abends.

## User response

If the CPUs were busy on the system at the time when the timeout occurred, code the PIPEWAIT control statement. For details of the statement, see "PIPEWAIT control statement" on page 152. If the timeout still occurs even if the PIPEWAIT control statement is coded, contact IBM Software Support.

---

<b>HPSG2005E</b>	<b>PIPE SERVICE ERROR IN tttttt OF PIPE ppppppppppppppppp; REASON=rrrrrrrr</b>
------------------	--

## Explanation

A pipe service requested by the reader or writer task *ttttt*, of pipe *pppppppppppppppppp* is aborted by an error in the task. The hexadecimal reason code *rrrrrrrr* shows the reason of the error and the status of the pipe at the time the error occurred. The reason code is the logical sum of the following reason flags:

Flag (hex)	Meaning
80000000	The pipe has been requested to open
40000000	The pipe has been requested to close
20000000	PUT processing for the pipe has been requested
10000000	GET processing for the pipe has been requested
01000000	Pipe OPEN, CLOSE, PUT, or GET processing is in progress
00800000	The task has a lock
00400000	The task is waiting for a lock
00200000	The task is waiting for the partner task to put data in the pipe or to get data from the pipe
00100000	This flag is used internally
00010000	The pipe is closed on this end
00008000	An error in the partner task is detected
00004000	The task is ending abnormally
00002000	A timeout occurred while a pipe request was being processed
00001000	An error occurred during the setting up of a recovery routine
00000800	A record passed to a PUT request is too large
00000400	The task stopped waiting for the partner task to open the pipe
00000080	The partner task ended abnormally
00000040	The partner task closed the pipe unexpectedly
00000020	A timeout occurred while the task was waiting for the partner task to open the pipe
00000010	The partner task could not wait for the current task to open the pipe
00000008	The task was requested to stop waiting for the partner task to open the pipe

## System action

The task abends with a user completion code of 2005.

## User response

Identify the cause of the error. If the cause is not found, contact IBM Software Support.

---

**HPSG2006E      PIPE SERVICE REQUESTED BY *ttttt* IS ABORTED FOR PIPE *pppppppppppppppppp*; REASON=*rrrrrrrr***

## Explanation

A pipe service requested by the reader or writer task *ttttt*, of pipe *pppppppppppppppppp* is aborted due to an error in the partner task. The hexadecimal reason code *rrrrrrrr* shows the reason of the error and the status of the pipe at the time the error occurred. For the meaning of the reason code, see the table of reason flags in Explanation of message HPSG2005E.

## System action

The task abends with a user completion code of 2006.

## User response

Identify the cause of the error in the partner task. If the cause is not found, contact IBM Software Support.

---

**HPSG2007E      PIPE *ttttt* ALREADY CLOSED THE PIPE *pppppppppppppppppp***

## Explanation

The reader or writer task, which is indicated by *ttttt*, tried to close the pipe *pppppppppppppppppp*, but the pipe has already been closed.

## System action

Message HPSG2005E follows and the task abends.

## User response

This error is likely an internal error. Contact IBM Software Support.

---

**HPSG2008I      PIPE *ttttt* WAITING FOR PARTNER TO OPEN PIPE *pppppppppppppppppp***

## Explanation

The reader or writer task, which is indicated by *ttttt*, is waiting for the partner task to open the pipe.



## System action

The task waits for the pipe open for 1 minute.

## User response

If the message is followed by message HPSG2009I issued from the partner task and message HPSG2010I, no action is required. If the message is followed by message HPSG2011E, something is wrong in the partner task. For example, the partner task ended abnormally before the pipe was opened.

---

**HPSG2009I**      **PIPE tttttt OPENED PIPE  
pppppppppppppppppp**

## Explanation

The reader or writer task, which is indicated by *ttttt*, opened the pipe waited by the partner task. Message HPSG2010I follows.

## System action

The task that issued the message continues processing.

## User response

None. This message is informational.

---

**HPSG2010I**      **PIPE CONNECTION ESTABLISHED  
FOR PIPE ppppppppppppppppp**

## Explanation

The connection to the pipe *pppppppppppppppppp* has been established. This message is issued from the task that issued the preceding message HPSG2008I for the pipe.

## System action

The task that issued the message and the partner task continue processing.

## User response

None. This message is informational.

---

**HPSG2011E**      **TIME-OUT WHILE PIPE tttttt  
WAITING FOR PARTNER TO OPEN  
PIPE ppppppppppppppppp**

## Explanation

If the partner task has not opened the pipe within a minute, this message is issued from the task that issued the preceding message HPSG2008I for the

pipe *pppppppppppppppppp*. Something is wrong in the partner task.

## System action

Message HPSG2006E follows and the task abends.

## User response

Identify the error in the partner task.

---

**HPSG2100I**      **THE TOSI SERVER IS NOT ACTIVE:  
imsid**

## Explanation

The IMS Tools Online System Interface server is not active in the IMS online subsystems indicated by *imsid*. The Smart Reorg utility cannot issue the IMS command /DBD or /DBR to the IMS online subsystems.

## System action

The Smart Reorg utility continues processing depending on the AUTHFAIL control statement.

## User response

Ensure that the IMS Tools Online System Interface server is active on the indicated IMS region. To continue the Smart Reorg utility processing, issue the IMS command manually.

---

**HPSG2101E**      **UNABLE TO ISSUE IMS  
COMMAND [/DBD|/DBR|/STA]  
AUTOMATICALLY**

## Explanation

The Smart Reorg utility cannot issue the IMS command (/DBD, /DBR, or /STA) automatically. The reason is shown in prior information message or in the IMS command processing report.

## System action

The Smart Reorg utility does not issue the command and ends with a return code of 8.

## User response

For /DBD and /DBR, check the reason and rerun the job. If AUTHFAIL=WTOR is specified, you can issue the /DBD or the /DBR command manually; then the Smart Reorg utility continues processing even in this situation. For /STA, issue the /STA command manually after taking appropriate actions.

---

**HPSG2102I      UNABLE TO ISSUE [/DBD]/DBR]  
BECAUSE DATABASE=*dbname* IS  
IN USE: *imsid***

### Explanation

The database *dbname* is in use in the IMS online subsystem *imsid*. The Smart Reorg utility cannot issue the IMS command /DBD or /DBR to the IMS online subsystems.

### System action

The Smart Reorg utility continues processing depending on the AUTHFAIL control statement.

### User response

End the program by using the database to continue Smart Reorg utility's processing.

---

**HPSG2103E      TOSI FUNC=*xxxxxxxxxx* ERROR:  
RC=*rc* RSN=*rsn***

### Explanation

The IMS Tools Online System Interface FUNC=*xxxxxxxxxx* returned an error.

### System action

The Smart Reorg utility ends with a return code of 8.

### User response

See the prior IMS Tools Online System Interface FOIxxxxx messages.

---

**HPSG2104I      IMS COMMAND [/DBD]/DBR]/STA]  
FAILED: DATABASE=*dbname***

### Explanation

The Smart Reorg utility attempted to issue the IMS command /DBD, /DBR or /STA to database *dbname* by using the IMS Tools Online System Interface. The processing, however, did not complete successfully.

### System action

The Smart Reorg utility continues processing.

### User response

Review the IMS Command Processing report and issue the IMS command manually.

---

**HPSG2104W      IMS COMMAND [/DBD]/DBR]/STA]  
FAILED: DATABASE=*dbname***

### Explanation

The Smart Reorg utility attempted to issue the IMS command /DBD, /DBR or /STA to database *dbname* by using the IMS Tools Online System Interface. The processing, however, did not complete successfully.

### System action

The Smart Reorg utility continues processing.

### User response

Review the IMS Command Processing report and issue the IMS command manually.

---

**HPSG2105I      IMS COMMAND [/DBD]/DBR]/STA]  
COMPLETED: DATABASE=*dbname***

### Explanation

The Smart Reorg utility issued the IMS command /DBD, /DBR or /STA to database *dbname* by using the IMS Tools Online System Interface (IMS TOSI), and the command completed successfully.

### System action

The Smart Reorg utility continues processing.

### User response

The command option and the IMSID of the online IMS subsystem to which the command that is issued is shown in the IMS Command Processing report.

---

**HPSG2106E      TOSI SUB TASK (ID: *xx*) ENDED  
ABNORMALLY (CC=*cccc*)**

### Explanation

The subtask indicated by string *xxxxxx* ended abnormally with a completion code of *cccc* due to an error in the task.

### System action

Message HPSG0011E is issued, and the Smart Reorg utility ends with a return code of 16.

### User response

See the previous IMS Tools Online System Interface FOIxxxxx messages.

---

**HPSG2108I      JOB NAME: *jobname*, PSB\_NAME:  
*psbname* IN *imsid***

## Explanation

This message provides additional information for message HPSG2102I.

*jobname* and *psbname* show the job and the PSB that are running in the IMS online subsystem (*imsid*) and that are interfering with the IMS command indicated in message HPSG2102I.

## System action

See message HPSG2102I.

## User response

See message HPSG2102I.

---

<b>HPSG2201I</b>	<b>OUTPUT REPOSITORY PROCESSING IS COMMITTED</b>
------------------	--

## Explanation

This is an information message showing that Smart Reorg utility committed to store the reports in the IMS Tools KB Output repository.

## System action

The Smart Reorg utility continues processing.

## User response

None. This message is informational.

---

<b>HPSG2202W</b>	<b>OUTPUT REPOSITORY PROCESSING IS CANCELED</b>
------------------	---

## Explanation

This is an information message showing that Smart Reorg utility canceled storing reports in the IMS Tools KB Output repository because an error occurred in reorganization or name swap processing.

## System action

The Smart Reorg utility continues processing.

## User response

None.

---

<b>HPSG2203I</b>	<b>LEVEL IS NOT HIGH ENOUGH TO SUPPORT OUTPUT REPOSITORY: <i>prodname</i></b>
------------------	---

## Explanation

The maintenance level of the prerequisite product *prodname* is not high enough to support the IMS Tools KB Output repository. *prodname* can be one of:

- IMS HP IMAGE COPY
- IMS HP POINTER CHECKER

## System action

The Smart Reorg utility continues processing.

## User response

If you want to save the product's reports to the IMS Tools KB Output repository, apply the maintenance to the product.

---

<b>HPSG2211W</b>	<b>THE ACCESS TO OUTPUT REPOSITORY WAS CANCELED. REASON: <i>reason</i></b>
------------------	--

## Explanation

The Smart Reorg utility canceled its access in the IMS Tools KB Output repository because its initialization process failed. The *reason* is one of the following:

### Reason

#### Meaning

#### ITKBLOAD DYNALLOC FAILURE

Dynamic allocation for the library specified in the ITKBLOAD control statement failed.

#### HKTXXLI LOAD FAILURE

Loading of the HKTXXLI module failed.

#### ITKBLOAD OPEN FAILURE

Opening of the library specified in the ITKBLOAD control statement failed.

#### ITKBLOAD NOT AUTHORIZED

Library specified in the ITKBLOAD control statement is not APF-authorized.

#### ITKB KEY AREA GETMAIN ERR

Failed to obtain a key area.

#### LOG D/S DCB GETMAIN ERR

Failed to obtain the DCB for a log data set.

## System action

Processing continues, but no reports are stored in the IMS Tools KB Output repository.

## User response

If you want to store reports in the IMS Tools KB Output repository, specify the IMS Tools KB product load module library correctly. For more information,

see "ITKBLOAD control statement" on page 144. If the reason is "ITKBLOAD NOT AUTHORIZED", the library must be APF-authorized.

---

**HPSG2212W      ERROR OCCURRED IN ACCESSING  
OUTPUT REPOSITORY FUNC:  
function RC: rc RSN: rsn**

### Explanation

An error occurred while accessing the IMS Tools KB Output repository. The hexadecimal value *rc* shows the return code and the hexadecimal value *rsn* shows the associated reason code that are returned from IMS Tools KB.

### System action

Processing continues. If the return code is equal to or greater than 8, no reports are stored in the IMS Tools KB Output repository.

### User response

If you want to store the reports in the IMS Tools KB Output repository, complete the appropriate action:

- If one or more of the messages, HPSG2220W, HPSG2221W, HPSG2222W, or HPSG2223W are issued after this message, see the explanation sections for those messages.
- If these messages are not issued, check the return code and the reason code that are specified in this message. For the description of the codes, see the *IMS Tools Base IMS Tools Knowledge Base User's Guide and Reference*.

---

**HPSG2213W      ERROR OCCURRED IN ACCESSING  
OUTPUT REPOSITORY FUNC:  
function RC: rc RSN: rsn**

### Explanation

An error occurred while getting access to the IMS Tools KB Output repository.

### System action

Processing continues. If the return code is equal to or greater than 8, the report shown in the HPSG2214W message and the following reports are not stored in the IMS Tools KB Output repository.

### User response

See the description for the HPSG2212W message.

---

**HPSG2214W      DBD: *dbdname* PART: *partname*  
REPORT: *report-name***

### Explanation

This message follows the HPSG2213W message to show which report is processed.

### System action

See the description for the HPSG2213W message.

### User response

See the description for the HPSG2213W message.

---

**HPSG2220W      RECON ENTRY WAS NOT FOUND  
IN ITKB**

### Explanation

The RECON entry was not found in your IMS Tools KB information management environment.

### System action

Processing continues, but no reports are stored in the IMS Tools KB Output repository.

### User response

If you want to store reports in the IMS Tools KB Output repository, check the RECON information in the IMS Tools Knowledge Base panel of the ISPF dialog and add a RECON environment. For details of the IMS Tools Knowledge Base panel and about adding the RECON environment, see the *IMS Tools Base IMS Tools Knowledge Base User's Guide and Reference* or the *IMS Tools Base Configuration Guide*.

---

**HPSG2221W      CONNECTION TO THE ITKB  
SERVER FAILED**

### Explanation

The connection to the IMS Tools KB server failed. This message might be issued for the following reasons:

- The server configuration is incomplete.
- The server is not started.
- The server XCF group name that is specified by the ITKBSRVR keyword is incorrect.
- Insufficient access authority to repository.

### System action

Processing continues, but no reports are stored in the IMS Tools KB Output repository.

### User response

Complete the following steps:

1. Ensure that the server XCF group name specified on the ITKBSRVR keyword is correct.
2. Ensure that the IMS Tools KB server is configured and started without any errors. For configuration steps, see the topic "Configuring IMS Tools Knowledge Base" in the *IMS Tools Base Configuration Guide*.

If the problem persists, contact your system administrator to obtain the required level of authorization

---

**HPSG2222W      IMS DB REORG EXPERT WAS NOT DEFINED IN ITKB**

### Explanation

IMS Database Reorganization Expert was not defined in the IMS Tools KB information management environment as a product that can store reports to the IMS Tools KB Output repository.

### System action

Processing continues, but the reports that are produced by IMS Database Reorganization Expert are not stored in the IMS Tools KB Output repository.

### User response

If you want to store reports in the IMS Tools KB Output repository, check the listing of the registered products and register IMS Database Reorganization Expert by using the IMS Tools KB product administration utility (HKTAPRA0). For more information, see the *IMS Tools Base IMS Tools Knowledge Base User's Guide and Reference* or the *IMS Tools Base Configuration Guide*.

---

**HPSG2223W      THE REPORT WAS NOT DEFINED IN ITKB**

### Explanation

The report was not defined in the IMS Tools KB information management environment.

### System action

Processing continues, but the report is not stored in the IMS Tools KB Output repository.

### User response

If you want to store the report in the IMS Tools KB Output repository, check the listing of the registered reports and register the report by using the IMS Tools KB product administration utility (HKTAPRA0). For more information, see the *IMS Tools Base IMS Tools*

*Knowledge Base User's Guide and Reference* or the *IMS Tools Base Configuration Guide*.

---

**HPSG2301I      LIU INTEGRITY CHECKER INITIALIZED**

### Explanation

IMS Library Integrity Utilities Integrity Checker has been initialized to create the RDE of each DBD or each HALDB partition.

### System action

The Smart Reorg utility processing continues.

### User response

None. This message is informational.

---

**HPSG2302E      LIU INTEGRITY CHECKER  
 FUNC=func\_name, RC=rc,  
 RSN=xxxx, [DBD=dbdname]  
 PART=partname]**

### Explanation

The Smart Reorg utility received an error from the IMS Library Integrity Utilities Integrity Checker. *func\_name* is the function name of the IMS Library Integrity Utilities Integrity Checker, *rc* is the return code, and *xxxx* is the reason code in decimals. For the detail of the error reason, see the FABLxxxxE message issued by the IMS Library Integrity Utilities Integrity Checker.

### System action

The Smart Reorg utility ends with a return code of 8.

### User response

See the explanation of the FABLxxxxE message.

---

**HPSG2303W      LIU INTEGRITY CHECKER  
 FUNC=func\_name, RC=rc,  
 RSN=xxxx, [DBD=dbdname]  
 PART=partname]**

### Explanation

The Smart Reorg utility received an error from the IMS Library Integrity Utilities Integrity Checker. *func\_name* is the function name of the IMS Library Integrity Utilities Integrity Checker, *rc* is the return code, and *xxxx* is the reason code in decimals. For the detail of the error reason, see the FABLxxxxE message issued by the IMS Library Integrity Utilities Integrity Checker.

## System action

The Smart Reorg utility continues processing.

## User response

See the explanation of the FABLxxxxE message.

---

<b>HPSG2304I</b>	<b>*TRACE* LIU INTEGRITY CHECKER FUNC=<i>func_name</i>, RC=<i>rc</i>, RSN=<i>xxxx</i>, [DBD=<i>dbdname</i>] PART=<i>partname</i>]</b>
------------------	---

## Explanation

The Smart Reorg utility received an error from the IMS Library Integrity Utilities Integrity Checker. *func\_name* is the function name of the IMS Library Integrity Utilities Integrity Checker, *rc* is the return code, and *xxxx* is the reason code in decimals. This message is shown only when DEBUG=B is specified in the (REORG) block.

## System action

The Smart Reorg utility continues processing.

## User response

None. This message is informational.

---

<b>HPSG2311W</b>	<b>CONDITIONAL REORG SERVICE RETURNED RC=<i>rc</i>, RSN=<i>rsn</i>. FUNC=<i>function</i></b>
------------------	--

## Explanation

The Smart Reorg utility received an error or a warning from the Conditional Reorganization Support Service (CRSS). *function* is the function name of the CRSS. *rc* and *rsn* are the return code and reason code in decimals.

## System action

Smart Reorg utility processing continues.

## User response

The meaning of the error or the warning is recorded in the journal messages that are issued by the CRSS. Correct the error and rerun the job. If you are notified that the name swapping process competed successfully by message HPSG0341I, you can accept the database reorganization.

---

<b>HPSG2312E</b>	<b>CONDITIONAL REORG SERVICE ERROR. FUNC=<i>function</i>, RC=<i>rc</i>, RSN=<i>rsn</i></b>
------------------	--

## Explanation

The Smart Reorg utility received an error from the Conditional Reorganization Support Service (CRSS). *function* is the function name of the CRSS. *rc* and *rsn* are the return code and reason code in decimals.

## System action

The Smart Reorg utility ends with a return code of 8.

## User response

The meaning of the error or the warning is recorded in the journal messages that are issued by the CRSS. Correct the error and rerun the job.

---

<b>HPSG2313W</b>	<b>CONDITIONAL REORG SERVICE IS DEACTIVATED DUE TO <i>reason</i></b>
------------------	--

## Explanation

The Conditional Reorganization Support Service (CRSS) cannot continue the job because of one of the following reasons.

### *reason*

#### Meaning

### **OLR-CURSOR ACTIVE**

OLR cursor is active in a partition.

### **HALDB DEFINITION ACCESS FAILURE**

The HALDB partition definition could not be obtained.

### **GETMAIN FAILURE**

A storage area could not be obtained.

### **DYNAMIC ALLOCATION FAILURE**

The allocation of a database data set failed.

### **LOAD FAILURE**

The Conditional Reorganization API module could not be loaded.

### **ITS FAILURE**

The CRSS failed. The cause of the error is shown in BBExxxxx messages.

### **UNSUPPORTED IMS LEVEL**

This level of IMS is not supported.

### **FREEMAIN FAILURE**

The storage area could not be freed.

### **UNSUPPORTED DATA SET TYPE**

The data set type that is defined for the original database data set is not supported.

## System action

Smart Reorg utility processing continues without the CRSS. If the job is run in Conditional Reorganization mode and if the error in the CRSS occurred before

reorganization need is determined or if the job is run in Reorganization Diagnosis mode, the runtime mode is switched to unconditional reorganization mode. In this case, message HPSG0001I follows this message.

## User response

Take one of the following steps that corresponds to the reason, and rerun the job:

### OLR-CURSOR ACTIVE

Run the reorganization job after the HALDB OLR ends.

### HALDB DEFINITION ACCESS FAILURE

Register the HALDB definition in RECON.

### GETMAIN FAILURE

Increase the region size for the job.

### DYNAMIC ALLOCATION FAILURE

Message HPSG0122E and HPSG0123I are issued before this message. Follow the directions in the user response sections of these messages.

### LOAD FAILURE

Specify the correct load library for IMS Database Reorganization Expert.

### ITS FAILURE

BBExxxxx error messages are issued before this message. Follow the user response sections of these messages.

### UNSUPPORTED IMS LEVEL

Use one of the supported versions of IMS.

### FREEMAIN FAILURE

This error is likely an internal system error. Contact IBM Software Support.

### UNSUPPORTED DATA SET TYPE

Ensure that the original database data set is valid. If the problem persists, contact IBM Software Support.

---

## HPSG2314I REORGANIZATION IS NOT NEEDED FOR DATABASE *dbname*

## Explanation

The Conditional Reorganization Support Service (CRSS) determined that the *dbname* database does not need to be reorganized.

## System action

The Smart Reorg utility does not start the reorganization processing.

## User response

None. This message is informational.

If you want to process the reorganization job, remove the CONDREORG=YES control statement and rerun the job.

---

## HPSG2316E CONTROL STATEMENT ERRORS WERE FOUND IN THE CONDREORG BLOCK

## Explanation

The Conditional Reorganization Support Service (CRSS) found control statement errors while analyzing the control statements in the (CONDREORG) block.

## System action

The Smart Reorg utility ends with a return code of 8.

## User response

The cause of the error is shown in the preceding BBExxxxx messages. See the BBExxxxx messages, correct the control statements in the (CONDREORG) block that is in the HPSIN data set, and rerun the job.

---

## HPSG2317I DB DIAGNOSIS DETECTED ONE OR MORE EXCEPTIONS IN DATABASE *dbname*

## Explanation

CONDREORG=YES,DIAGONLY was specified in the (REORG) block. The Conditional Reorganization Support Service (CRSS) evaluated the *dbname* database and detected one or more database exceptions.

## System action

The Smart Reorg utility continues processing.

## User response

Check the exceptions in the Diagnosis report. If the database needs to be reorganized, specify CONDREORG=YES or delete the CONDREORG statement in the (REORG) block in the JCL. Then, rerun the job.

---

## HPSG2318I DB DIAGNOSIS DETECTED NO EXCEPTION IN DATABASE *dbname*

## Explanation

CONDREORG=YES,DIAGONLY was specified in the (REORG) block. The Conditional Reorganization Support Service (CRSS) evaluated the *dbname* database and detected no database exceptions.

## System action

The Smart Reorg utility continues processing.

## User response

None. This message is informational.

---

**HPSG2319I**      **EVENT "event\_name" IS  
DETECTED AND RC\_CHANGE WILL  
BE APPLIED**

## Explanation

The event that was specified by the RC\_CHANGE control statement is detected. The return code of the Smart Reorg utility is changed as specified on the RC\_CHANGE control statement.

The event that is indicated by *event\_name* is:

### **POLICY.EXCEPTIONS.CRITICAL**

Critical-level exceptions remain in the database.

### **POLICY.ACTION.REORG**

The database requires a reorganization.

## System action

The Smart Reorg utility ends with the return code that is specified by the RC\_CHANGE control statement.

## User response

None. This message is informational.

---

**HPSG2320E**      **CONDITIONAL REORG SERVICE IS  
DEACTIVATED DUE TO *reason***

## Explanation

The Conditional Reorganization Support Service (CRSS) cannot continue the job because of one of the following reasons.

### ***reason***

#### **Meaning**

### **NO ITKB SERVER**

An IMS Tools KB server is not specified.

### **REORGINPUT=ULDS**

REORGINPUT=ULDS is specified.

### **USING NEWDBD**

NEWDBD=*ddname* is specified.

### **MULTIPLE PARTITIONS SPECIFIED**

Two or more partitions are specified by PARTITION=(*partname,n*) control statement and a partition selection exit is defined for the HALDB.

### **USING ITKBLOAD**

ITKBLOAD=*libname* is specified.

## System action

The Smart Reorg utility ends with a return code of 8.

## User response

Take one of the following steps that corresponds to the reason, and rerun the job:

### **NO ITKB SERVER**

Add the ITKBSRVR control statement to the HPSIN data set.

### **REORGINPUT=ULDS**

REORGINPUT=ULDS is not supported. To use the CRSS, specify REORGINPUT=DBDS.

### **USING NEWDBD**

The NEWDBD control statement is not supported. To use the CRSS, do not specify a new DBD. Instead, specify an existing DBD.

### **MULTIPLE PARTITIONS SPECIFIED**

Specify the partitions to be diagnosed by using the PARTITION=(*part1,part2,...,part10*) statement.

### **USING ITKBLOAD**

ITKBLOAD=*libname* is not supported. To use the CRSS, do not specify ITKBLOAD=*libname*.

---

**HPSG2321I**      **DATABASE *dbdname* IS  
REORGANIZED BECAUSE REORG  
DIAGNOSIS MODE IS SELECTED**

## Explanation

CONDREORG=YES,REORGDIAG was specified in the (REORG) block so the job is run in Reorganization Diagnosis mode. The indicated database is reorganized regardless of its status.

## System action

The Smart Reorg utility continues processing.

## User response

None. This message is informational.

---

**HPSG2322I**      **SHADOW DATA SETS ARE  
DIAGNOSED AS REORGANIZED  
DATABASE**

## Explanation

The database was reorganized but the name swapping was not done because the NAMESWAP=NO option was specified. The Conditional Reorganization Support Service (CRSS) evaluated the shadow data sets after reorganization.



## System action

The Smart Reorg utility continues processing.

## User response

None. This message is informational.

---

**HPSG2323I REORGANIZATION IS NEEDED  
FOR DATABASE *dbname***

## Explanation

The Conditional Reorganization Support Service (CRSS) determined that the *dbname* database needs to be reorganized.

## System action

The Smart Reorg utility starts the reorganization processing.

## User response

None. This message is informational.

---

**HPSG2330E DBRC API FUNC= *function*,  
[TYPE=[RECON | SUBSYS |  
DB,DBD=*dbname*],]RC=*rc*,RSN=*rsn***

## Explanation

The Smart Reorg utility received an error return code from the DBRC API during DBRC processing. *function* is the function name of the DBRC API, *type* is the type of the DBRC query request, *rc* is the return code in decimal, and *rsn* is the reason code in hexadecimal format. IMS DBRC messages (DSPxxxxx) might be printed in the HPSDSPAP data set or the HPSOUT2 data set to provide additional information.

## System action

The Smart Reorg utility ends with a return code of 8.

## User response

See *IMS System Programming APIs* and look up the meaning of the return code and reason code. For IMS DBRC messages, see *IMS Messages and Codes*.

---

**HPSG2331I AN ERROR OCCURRED IN  
HKTEXST CALL: FUNCTION=*func***

## Explanation

An error occurred in a HKTEXST API call. HKTEXST is a module provided by IMS Tools Base IMS Tools Knowledge Base.

## System action

The Smart Reorg utility or the Post-reorganization utility continues processing without storing utility history data in the IMS Tools KB repository.

## User response

Locate message HKT $Xnnnn$ , which is issued after this message, and see the explanation of the message in the *IMS Tools Base IMS Tools Knowledge Base User's Guide and Reference*. If you need to create a trace log for the HKTEXST API call to send it to IBM Software Support, specify the HKT $XLOG$  DD statement in the JCL.

---

**HPSG2332I HPSGES00 PROCESSING FAILED.  
RSN=*reason\_code***

## Explanation

An error occurred before issuing HKTEXST API calls. *reason\_code* indicates the error cause:

### 001

Failed to obtain the RECON ID.

### 002

Failed to load the HKTRRCN load module.

### 003

Failed to load the HKTEXTM0 load module.

### 004

Failed to load the HKTEXSTO load module.

### 005

Failed to initialize the HKTEXTM0 load module (FUNC=INIT).

### 006

Failed to terminate the HKTEXTM0 load module (FUNC=TERM).

## System action

The Smart Reorg utility or the Post-reorganization utility continues processing without storing utility history data in the IMS Tools KB repository.

## User response

If the reason code is 001, ensure that the RECON ID is defined to the IMS Tools Knowledge Base. For other reason codes, ensure that the maintenance level of the

IMS Tools Base load library (*hlq*.SHKTLOAD) is at the required level.

---

**HPSG2998E      PIPE IS NOT OPENED.  
                  GPR2=ADDR(PDCB)**

### Explanation

The reader or writer task tried to close the pipe that has not been opened.

### System action

The task abends with a completion code of U2998.

### User response

This error is likely an internal error. Contact IBM Software Support.

---

**HPSG3100E      GETMAIN ERROR (RC=xx) IN  
                  MODULE aaaaaaaaa**

### Explanation

A storage area is requested in the module *aaaaaaaa* by using the GETMAIN macro, but an error return code of *xx* is returned.

### System action

The subtask that issued the GETMAIN request abends with a user completion code of 3100, and the Smart Reorg utility ends with a return code of 8.

### User response

Identify the cause of the GETMAIN error by referring to *z/OS MVS Assembler Services Reference*.

---

**HPSG3101E      OPEN FAILED FOR DDNAME:  
                  ddname**

### Explanation

An attempt to open the data set indicated by the DD name *ddname* failed.

### System action

Reorganization Manager abends with a user completion code of 3101, and the Smart Reorg utility ends with a return code of 16.

### User response

Identify the cause of the open error.

---

**HPSG3102E      INTERNAL ERROR IN BLOCK  
                  BUILDER: FUNCTION= xxxxxxxx,  
                  RC=yy**

### Explanation

There was an internal error while the control blocks were being built.

### System action

Unload task abends with a user completion code of 3102, and the Smart Reorg utility ends with a return code of 16.

### User response

Correct the following data and contact IBM Software Support:

- The job log
- The source file of DBDGEN for the original DBD
- The source file of DBDGEN for the new DBD (if the NEWDBD control statement is specified)

---

**HPSG3103E      MCSOPER [ACTIVATE |  
                  DEACTIVATE] FAILED RC= rrrr  
                  RSN= ssssssss**

### Explanation

The MCSOPER macro failed with return code *rrrr* and reason code *sssssss*.

### System action

Reorganization Manager issues a U3103 abend and the Smart Reorg utility ends with a return code of 16.

### User response

Refer to *z/OS MVS Authorized Assembler Services Reference* for the meaning of the return code and reason code. Correct the error, and rerun the job.

---

**HPSG3104E      MCSOPMSG FAILED RC= rrrr RSN=  
                  sssssss**

### Explanation

MCSOPMSG macro failed with return code *rrrr* and reason code *sssssss*.

### System action

Reorganization Manager issues a U3104 abend and the Smart Reorg utility ends with a return code of 16.

## User response

Refer to *z/OS MVS Authorized Assembler Services Reference* for the meaning of the return code and reason code. Correct the error, and rerun the job.

---

**HPSG3105E      TIME-OUT WHILE WAITING FOR  
COMMAND RESPONSE**

## Explanation

Timeout occurred while waiting for IMS command response.

## System action

Reorganization Manager issues a U3105 abend, and the Smart Reorg utility ends with a return code of 16.

## User response

Check if the IMS online region is operable. Correct the error, if any, and rerun the job.

---

**HPSG3106E      REQUIRED DBNAME LIST NOT  
SPECIFIED**

## Explanation

The DB name list required for the requested IMS command is not specified.

## System action

Reorganization Manager issues a U3106 abend and the Smart Reorg utility ends with a return code of 16.

## User response

Internal error. Contact IBM Software Support.

---

**HPSG3107E      UNKNOWN IMS COMMAND  
REQUESTED**

## Explanation

Unknown IMS command is requested by the caller.

## System action

Reorganization Manager issues a U3107 abend, and the Smart Reorg utility ends with a return code of 16.

## User response

Internal error. Contact IBM Software Support.

---

**HPSG3108E      REQUIRED PC ENVIRONMENT NOT  
ESTABLISHED**

## Explanation

The PC environment which is required for the IMS command processing is not established.

## System action

Reorganization Manager issues a U3108 abend, and the Smart Reorg utility ends with a return code of 16.

## User response

This error is likely an internal error. Contact IBM Software Support.

---

**HPSG3109E      INTERNAL ERROR OCCURRED  
WHILE BUILDING DBD NAME  
LIST: RC=*rc*, RSN=*rsn***

## Explanation

An internal error occurred while creating a DBD name list.

## System action

The subtask that caused the internal error abends with a user completion code of 3109, and the Pre-reorganization utility ends with a return code of 16.

## User response

Contact IBM Software Support.

---

**HPSG3200E      *xxxx* TASK IS ENDING (RC=*rc*)  
WITHOUT HAVING CLOSED PIPE  
*pppppppppppppppppppp***

## Explanation

The task indicated by the string *xxxx* is ending without closing the pipe *pppppppppppppppppppp* with a return code of *rc*.

## System action

The task ends abnormally.

## User response

This error is likely an internal system error. Contact IBM Software Support.

---

**HPSG3201E      OPEN FAILED FOR DDNAME:  
*ddname***

## Explanation

An attempt to open the data set *ddname* failed.

## System action

Reorganization Manager issues a U3201 abend, and the Smart Reorg utility ends abnormally.

## User response

Check the error, and rerun the job.

---

<b>HPSG3202E</b>	<b>BLDL MACRO FAILED FOR MEMBER: <i>member_name</i> (RC=<i>rc</i>, RSN=<i>rsn</i>)</b>
------------------	--

## Explanation

The BLDL macro failed for member *member\_name*. The return code and the reason code from the macro call were *rc* and *rsn*.

## System action

Reorganization Manager issues a U3202 abend, and the Smart Reorg utility ends abnormally.

## User response

This error is likely an internal system error. Contact IBM Software Support.

---

<b>HPSG3203I</b>	<b>IMS MANAGED ACBS ENABLED</b>
------------------	---------------------------------

## Explanation

The IMS management of ACBs is enabled.

## System action

Processing continues.

## User response

None. This message is informational.

---

<b>HPSG3204E</b>	<b>INCORRECT IMS CATALOG SYSDSHLQ=<i>hlq</i></b>
------------------	--

## Explanation

The IMS catalog system data set allocated by IMS Catalog API (DFS3CATQ) is not the same as the data set allocated by the IMS control region.

## System action

Reorganization Manager issues a U3204 abend and the Smart Reorg utility ends with a return code of 16.

## User response

Contact IBM Software Support.

---

<b>HPSG3205E</b>	<b>PARTITION SELECTION FAILURE OCCURRED; REQUEST=<i>xxxxxx</i> RC=<i>return_code</i>, RSN=<i>reason_code</i></b>
------------------	--

## Explanation

The DL/I DFSPSEL macro returned an error return code. *xxxxxx* is the request type of partition selection (the PART parameter value for the DFSPSEL macro), RC shows the return code, and RSN shows the reason code.

## System action

Reorganization Manager issues a U3205 abend and the Smart Reorg utility ends with a return code of 16.

## User response

If a corresponding IMS message (DFSnnnn) is issued, see the user response for that IMS message. Then, correct the error and rerun the job. If necessary, contact IBM Software Support.

---

<b>HPSG3206E</b>	<b>AUTHORIZATION FAILURE OCCURRED IN DBDNAME=<i>dbdname</i></b>
------------------	---

## Explanation

The Smart Reorg utility received an error return code from the IMS authorization module DFSDBAU0 for database *dbdname*.

## System action

Reorganization Manager issues a U3206 abend and the Smart Reorg utility ends with a return code of 16.

## User response

Make sure that the database is authorized before reorganization.

## HPSR messages

Messages that are issued by IMS HP Load begin with HPSR.

These messages are explained in the *IMS High Performance Load User's Guide*. See the topics on messages and codes in that guide.

## HPSS messages

Messages that are issued by the IPR DB Scan utility begin with HPSS.

---

**HPSS0001I DB SCAN FUNCTION ENDED,  
HIGHEST RETURN CODE IS xx**

### Explanation

The IPR DB Scan utility job ended. The decimal return code *xx* shows the result of the processing. For the meaning of each return code, see [“Return codes” on page 661](#).

### System action

The IPR DB Scan utility ends its processing.

### User response

Check the return code. Check the accompanying HPSUxxxxx or HPSSxxxxx messages issued from the IPR DB Scan utility or FABHxxxxx messages from HSSR Engine.

---

**HPSS0006E DATABASE 'database-name' NOT  
FOUND IN DFSURCDS DATA SET**

### Explanation

The database specified on the DBS= statement was not found in the DFSURCDS data set.

### System action

The IPR DB Scan utility ends with a return code of 8.

### User response

Correct the error, and rerun the IPR DB Scan utility job.

---

**HPSS0007E SEGMENT 'segment-name' NOT  
FOUND IN DFSURCDS DATA SET**

### Explanation

The segment specified on the DBS= statement was not found in the DFSURCDS data set.

### System action

The IPR DB Scan utility ends with a return code of 8.

### User response

Correct the error, and rerun the IPR DB Scan utility job.

---

**HPSS0008E DATABASE 'database-name' NOT  
SPECIFIED AS A DATABASE TO BE  
SCANNED**

### Explanation

The database specified on the DBS= statement is not specified, in the DFSURCDS data set, as the database to be scanned.

### System action

The IPR DB Scan utility ends with a return code of 8.

### User response

Specify a correct database name, and rerun the IPR DB Scan utility job.

---

**HPSS0010W INVALID SCAN METHOD  
SPECIFIED**

### Explanation

The scan method specified in the DBS= statement was not SEG or SEQ.

### System action

The IPR DB Scan utility ignores the incorrect scan method. If it is an HD database, the IPR DB Scan utility scans the database with the SEG method, or if it is a HISAM database, the IPR DB Scan utility scans the database with the SEQ method.

### User response

Specify a correct scan method, and rerun the IPR DB Scan utility job.

---

**HPSS0011I DATABASE 'database-name' HAS  
BEEN SCANNED**

### Explanation

The database *database-name* has been scanned.

## System action

The IPR DB Scan utility continues processing.

## User response

None. This message is informational.

---

**HPSS0012E      DATABASE NOT SCANNED:  
                  database-name**

## Explanation

The database *database-name* was not scanned. Message HPSS0013E is issued before this message.

## System action

The IPR DB Scan utility ends the job with a return code of 8.

## User response

Correct the error, and rerun the IPR DB Scan utility job.

---

**HPSS0013E      SEGMENT NOT SCANNED:  
                  database-name,segment-name**

## Explanation

The IPR DB Scan utility found one or more of the following errors when checking the DBD for the *segment-name*:

- The *segment-name* was not found in the DBD for the *database-name*.
- The *segment-name* is not involved in any logical relationships with any of the segments in the databases listed in the control data set as being initially loaded or reorganized.

## System action

The IPR DB Scan utility ends the job with a return code of 8.

## User response

Correct the error, and rerun the IPR DB Scan utility job.

---

**HPSS0014E      DB SCAN FUNCTION GOT CODE  
                  'GG'**

## Explanation

The IPR DB Scan utility issued an HSSR call, and the status code GG was returned from the HSSR call handler.

## System action

The IPR DB Scan utility ends the job with a return code of 8.

## User response

See the problem determination and take an appropriate action.

## Problem determination

Check if the right version of DBDs was being used. Check if the database processed by the IPR DB Scan utility was being updated.

---

**HPSS0016I      nnn,nnn,nnn DB RECORDS  
                  SCANNED - DBD=*dbdname*  
                  PART=*ddname***

## Explanation

*nnn,nnn,nnn* database records of database *dbdname* have been scanned. PART=*ddname* is displayed only for a partitioned database; the database records are counted within each partition. This information message enables you to monitor the IPR DB Scan utility job progress.

## System action

The IPR DB Scan utility continues processing.

## User response

None. This message is informational.

---

**HPSS0017I      HPSGCTL DD IS FOUND. THE IPR  
                  DB SCAN UTILITY GENERATES A  
                  RESULT DATA SET**

## Explanation

The IPR DB Scan utility found an HPSGCTL DD statement in the JCL stream. The IPR DB Scan utility generates a result data set for the subsequent Post-reorganization utility job.

## System action

The IPR DB Scan utility continues processing.

## User response

None. This message is informational.

---

**HPSS0019W      IMS DB REORG EXPERT IS NOT IN  
                  REQUIRED LEVEL FOR ADXCGRP  
                  STATEMENT**

## Explanation

The release level or the maintenance level of IMS Database Reorganization Expert does not support the ADXCFGRP control statement for the IPR DB Scan utility.

## System action

The IPR DB Scan utility continues processing without sending a system notification to Autonomics Director.

## User response

If you want to send a system notification to Autonomics Director, apply the PTF for APAR PM87124 to IMS HP Unload. Otherwise, remove the ADXCFGRP control statement.

---

**HPSS3000E OPEN FAILED FOR DDNAME:  
*ddname***

## Explanation

The IPR DB Scan utility could not open the data set specified by *ddname*.

## System action

The IPR DB Scan utility ends abnormally.

## User response

Correct the error, and rerun the IPR DB Scan utility job.

## Problem determination

Check if a *ddname* DD statement is specified in the JCL stream. If there is, check the JCL system messages to find the reason for the open error.

---

**HPSS3001E GETMAIN FAILED**

## Explanation

An error occurred in the GETMAIN macro. This is caused by insufficient virtual storage in the address space.

## System action

The IPR DB Scan utility ends abnormally.

## User response

Make sure that sufficient virtual storage is available.

---

**HPSS3004E UNABLE TO BUILD CONTROL  
BLOCK FOR DATABASE: *database-  
name***

## Explanation

The IPR DB Scan utility requested construction of control blocks for the *database-name*. The request was not successfully completed.

## System action

The IPR DB Scan utility ends abnormally.

## User response

Make sure that a valid DBD exists for the named database, and rerun the IPR DB Scan utility job.

---

**HPSS3005E DEFINED LPCK LENGTH IS ZERO**

## Explanation

The concatenated key length of the logical parent is defined as zero byte long. This could be caused by a field definition specifying NAME=xx rather than NAME=(xx,SEQ,U).

## System action

The IPR DB Scan utility ends abnormally.

## User response

Correct the field definition, and rerun the IPR DB Scan utility.

---

**HPSS3006E NOT FOUND IMS CONTROL  
BLOCKS FOR LOGICAL RELATED  
SEGMENT**

## Explanation

The IPR DB Scan utility attempted to locate IMS control blocks for segments involved in a logical relationship, but nothing was found.

## System action

The IPR DB Scan utility ends abnormally.

## User response

Verify that valid DBDs are available for the database being initially loaded, reloaded, or scanned.

---

**HPSS3007E DYNAMIC LIMIT-CHECK FAILED**

## Explanation

The IPR DB Scan utility was performing a dynamic limit-check as described in *IMS Database Utilities*, but the limit-check failed. See also the discussion of the Database Prefix Resolution utility in the same topic.

## System action

The Database Prereorganization utility (DFSURPRO) provides diagnostic messages that indicate the segments for which the limit-check failure occurred.

## User response

Refer to the explanation about limit checks in *IMS Database Utilities*. Take an appropriate action.

---

**HPSS3008E      FREEMAIN FAILED**

## Explanation

An error occurred in the FREEMAIN macro.

## System action

The IPR DB Scan utility ends abnormally.

## User response

Correct the error and rerun the job.

---

**HPSS3009E      SEGMENT NAME CANNOT BE  
SPECIFIED ON THE DBS CONTROL  
STATEMENT**

## Explanation

A segment name is specified on the DBS control statement. However, a segment name cannot be

## HPSU messages

Messages that are issued by the IPR Unload utility and the IPR DB Scan utility begin with HPSU.

---

**HPSU3001I      UNLOAD FUNCTION ENDED,  
HIGHEST RETURN CODE IS *xx*  
(REASON CODE: *yyyy*)**

## Explanation

The IPR Unload utility processing ended. The decimal return code *xx* shows the result of the processing. For the meaning of each return code and reason code, see [“IPR Unload utility return codes”](#) on page 662.

## System action

The IPR Unload utility ends its processing.

## User response

Check the return code. If the return code is 4, check the reason code, too. Check the accompanying HPSUxxxxx messages issued from the IPR Unload utility or FABHxxxxx messages from HSSR Engine.

specified when the HPSGCTL DD statement is specified.

## System action

The IPR DB Scan utility ends with a return code of 8.

## User response

Correct the DBS control statement specification and rerun the IPR DB Scan utility job.

---

**HPSS3010E      RDJFCB MACRO FAILED ON  
DDNAME: *ddname* (RC=*rc*)**

## Explanation

The RDJFCB MACRO failed for the indicated DD. *rc* shows the return code from the macro call.

## System action

The IPR DB Scan utility ends abnormally.

## User response

This error is likely an internal system error. Contact IBM Software Support.

## Explanation

The Unload task of the Smart Reorg utility is forced to end because of an error in another task.

## System action

The IPR Unload utility task ends with a return code of 8.

## User response

Check the task that originated the error. Correct the error and rerun the job.

---

**HPSU3003I      DFSISVIO EXIT IS CALLED AND  
IPR UNLOAD UTILITY IS BEING  
INVOKED**



## Explanation

This message notifies the user that the IMS exit DFSISVIO is called, and the IPR Unload utility is invoked by IMS batch region controller as the unload program.

## System action

IMS continues processing. The unload function is provided by the IPR Unload utility.

## User response

None. This message is informational.

---

<b>HPSU3004I</b>	<b>DFSISVIO EXIT IS CALLED BUT IPR UNLOAD UTILITY CANNOT BE INVOKED</b>
------------------	---

## Explanation

This message notifies the user that the IMS exit DFSISVIO is called but the IPR Unload utility cannot be invoked because of one of the following reasons:

- DFSUCKPT DD or DFSURSRT DD is coded.
- An unknown option other than PARTITION, MIGRATE, and FALLBACK is coded in the SYSIN data set.

## System action

IMS continues the processing and IMS HD unload utility (DFSURGUO) is invoked.

## User response

None. This message is informational.

---

<b>HPSU3011E</b>	<b>SEQ_BUF_AMOUNT IS TOO LOW; MINIMUM IS 2</b>
------------------	--

## Explanation

The value of *seq\_buf\_amount* is lower than the acceptable minimum.

## System action

The IPR Unload utility issues message HPSU3360E and ends its processing.

## User response

Correct the second parameter of the BUFFERS control statement.

---

<b>HPSU3012E</b>	<b>SEQ_BUF_AMOUNT IS TOO HIGH; MAXIMUM IS 255</b>
------------------	---

## Explanation

The value of *seq\_buf\_amount* is higher than the acceptable maximum.

## System action

The IPR Unload utility issues message HPSU3360E and ends its processing.

## User response

Correct the second parameter of the BUFFERS control statement.

---

<b>HPSU3013E</b>	<b>SEQ_BUF_NUM IS TOO LOW; MINIMUM IS 3</b>
------------------	---

## Explanation

The value of *seq\_buf\_num* is lower than the acceptable minimum.

## System action

The IPR Unload utility issues message HPSU3360E and ends its processing.

## User response

Correct the third parameter of the BUFFERS control statement.

---

<b>HPSU3014E</b>	<b>SEQ_THRESHOLD IS TOO LOW; MINIMUM IS 1</b>
------------------	---

## Explanation

The value of *seq\_threshold* is lower than the acceptable minimum.

## System action

The IPR Unload utility issues message HPSU3360E and ends its processing.

## User response

Correct the fifth parameter of the BUFFERS control statement.

---

<b>HPSU3015E</b>	<b>SEQ_THRESHOLD IS TOO HIGH; MAXIMUM IS 200</b>
------------------	--

## Explanation

The value of *seq\_threshold* is higher than the acceptable maximum.

### System action

The IPR Unload utility issues message HPSU3360E and ends its processing.

### User response

Correct the fifth parameter of the BUFFERS control statement.

---

<b>HPSU3016E</b>	<b>DIR_BUF_NUM IS TOO LOW; MINIMUM IS 2</b>
------------------	---

### Explanation

The value of *dir\_buf\_num* is lower than the acceptable minimum.

### System action

The IPR Unload utility issues message HPSU3360E and ends its processing.

### User response

Correct the fourth parameter of the BUFFERS control statement.

---

<b>HPSU3018E</b>	<b>SPECIFY EITHER "YES" OR "NO" (xxxxxxx)</b>
------------------	---

### Explanation

The IPR Unload utility detected an incorrect control statement.

### System action

The IPR Unload utility issues message HPSU3360E and ends its processing.

### User response

Correct the xxxxxxx control statement.

### Problem determination

The utility control statement does not allow a specification other than YES or NO.

---

<b>HPSU3022E</b>	<b>SEQ_BUF_NUM IS TOO HIGH; MAXIMUM IS 9999</b>
------------------	---

### Explanation

The value of *seq\_buf\_num* is higher than the acceptable maximum.

### System action

The IPR Unload utility issues message HPSU3360E and ends its processing.

### User response

Correct the third parameter of the BUFFERS control statement.

---

<b>HPSU3023E</b>	<b>DIR_BUF_NUM IS TOO HIGH; MAXIMUM IS 255</b>
------------------	--

### Explanation

The value of *dir\_buf\_num* is higher than the acceptable maximum.

### System action

The IPR Unload utility issues message HPSU3360E and ends its processing.

### User response

Correct the fourth parameter of the BUFFERS control statement.

---

<b>HPSU3030E</b>	<b><i>statement1</i> AND <i>statement2</i> STATEMENTS ARE MUTUALLY EXCLUSIVE</b>
------------------	--

### Explanation

The indicated control statements cannot be specified together because they are mutually exclusive.

### System action

The IPR Unload utility issues message HPSU3360E and ends its processing.

### User response

Correct the specification of the HPSIN DD statement. If you are using JCL for IMS HD Reorganization Unload, correct the specification of the SYSIN DD statement. Rerun the IPR Unload job.

---

<b>HPSU3031E</b>	<b>OUTPUT CANNOT BE SPECIFIED MORE THAN ONCE IF [MIGRATE=YES   FALLBACK=YES] IS SPECIFIED</b>
------------------	---

### Explanation

When the MIGRATE=YES or FALLBACK=YES control statement is specified, more than one OUTPUT control statement cannot be specified.

### System action

The IPR Unload utility issues message HPSU3360E and ends its processing.

### User response

Correct the specification of the HPSIN DD statement and rerun the IPR Unload job.

---

<b>HPSU3032E</b>	<b>INVALID UNLOAD FORMAT IS SPECIFIED WITH [MIGRATE=YES   FALLBACK=YES]</b>
------------------	---

### Explanation

Although MIGRATE=YES or FALLBACK=YES is specified, a format other than \*HD is specified on the OUTPUT control statement.

### System action

The IPR Unload utility issues message HPSU3360E and ends its processing.

### User response

Specify \*HD format for the OUTPUT control statement and rerun the IPR Unload job.

---

<b>HPSU3033I</b>	<b>DECODEDBD IS IGNORED BECAUSE LEVEL OF REORG EXPERT IS NOT HIGH ENOUGH</b>
------------------	--

### Explanation

DECODEDBD=YES was ignored because the maintenance level of IMS Database Reorganization Expert is not high enough to decode the DBD in an IMS-managed ACBs environment.

### System action

The IPR Unload utility ignores the DECODEDBD=YES statement and continues processing.

### User response

Apply the maintenance to IMS Database Reorganization Expert.

---

<b>HPSU3096E</b>	<b>xxxxxxx STATEMENT IS SPECIFIED TWICE</b>
------------------	---

### Explanation

The control statement xxxxxxxx is specified twice. The statement must be specified only once.

### System action

The IPR Unload utility ends with a return code of 8.

### User response

Correct the control statements, and rerun the job.

---

<b>HPSU3110E</b>	<b>IPR IS NOT INSTALLED OR NOT IN REQUIRED LEVEL</b>
------------------	--

### Explanation

To run the IPR Unload utility by using JCL for IMS HD Reorganization Unload (DFSURGU0), the library of IMS Database Reorganization Expert 4.1 or later is required. However, this library was not found or the maintenance level is not current.

### System action

The IPR Unload utility ends abnormally.

### User response

Install IMS Database Reorganization Expert, or apply the required maintenance to IMS Database Reorganization Expert.

---

<b>HPSU3157W</b>	<b>COMPRESSED SEGMENTS MUST BE DECOMPRESSED BEFORE CONVERSION; DECOMPRESS=NO IS IGNORED</b>
------------------	---

### Explanation

The data conversion exit routine is designated to be used for a compressed segment, but DECOMPRESS=YES is not specified in the HPSIN data set. The segment must be decompressed so that the data conversion using DFSDBUX1 can be done.

### System action

The IPR Unload utility sets DECOMPRESS=YES dynamically and continues processing.

### User response

Specify the DECOMPRESS=YES option in the HPSIN data set in the next JCL run.

---

<b>HPSU3158W</b>	<b>DECOMPRESS=YES FORCED SINCE KEY COMPRESSION OPTION IS SPECIFIED FOR THE ROOT SEGMENT</b>
------------------	---

## Explanation

DECOMPRESS=YES was not specified although the key compression option is specified for the root segment of the database. This message is issued for a HIDAM and PHIDAM database when the CS format is specified. This message is issued also when the F6 format is specified for the unload data set.

## System action

DECOMPRESS=YES is forced and the IPR Unload utility continues processing.

## User response

If you want to unload the database without decompressing segments, use an output record format other than CS and F6 formats. Otherwise, you can ignore the message.

---

**HPSU3159E      UNSUPPORTED OPTION FOR OLR  
ACTIVE PARTITIONS: *option***

## Explanation

The option (*option*) is specified, but this is one of the following options with which HSSR Engine cannot process the HALDB when the Online Reorganization (OLR) is active for one or more partitions of the HALDB:

- DECOMPRESS=NO
- User exit
- \*CS format for PHDAM
- \*A1 format
- PARTITION=*partlist*

## System action

The IPR Unload utility ends abnormally.

## User response

Remove this option or rerun after HALDB OLR for all the partitions are completed.

---

**HPSU3160W      ONLINE REORG ACTIVE  
FOR PARTITION=*pppppppp*  
(DBD=*dddddddd*)**

## Explanation

The HALDB Online Reorganization (OLR) processing for the partition *pppppppp* was stopped before completion and the OLR cursor is still active. HSSR Engine processes the partition which is comprised of both the A-J and X data sets as well as the M-V and Y data sets.

## System action

The IPR Unload utility continues processing. If one of the following options is specified, it is ignored: BYINDEX=YES, COMPAREDLI=YES, DBSTATS=YES, KEYCHECK=ABEND/GG/GX, or SKIPERROR=*nnnnn*.

## User response

See the additional message.

---

**HPSU3161E      PARTITION SELECTION FAILURE  
OCCURRED; REQUEST=*xxxxxx*  
RC=*return\_code*, RSN=*reason\_code***

## Explanation

The DL/I DFSPSEL macro returned an error return code. *xxxxxx* is the request type of partition selection (the PART parameter value for the DFSPSEL macro), RC shows the return code, and RSN shows the reason code.

## System action

The IPR Unload utility ends abnormally.

## User response

If a corresponding IMS message (DFS*nnnn*) is issued, see the user response for that IMS message. Then, correct the error and rerun the job. If necessary, contact IBM Software Support.

---

**HPSU3170I      RAPCHECK DETECTS NO  
INCORRECT RAP**

## Explanation

The RAPCHECK exit (HPSURPCX) detected no incorrect RAP chain.

## System action

The IPR Unload utility continues processing.

## User response

None. This message is informational.

---

**HPSU3171W      RAPCHECK DETECTS  
INCORRECT RAPS: TOTAL  
ROOTS=*nn,nnn,nnn,nnn***

## Explanation

The RAPCHECK exit (HPSURPCX) detected one or more incorrect RAP chains.

## System action

The IPR Unload utility continues processing and the unload data set is produced.

## User response

Check the HDAM RAPCHECK Incorrect RAP Chain report. It is recommended that the unload records are sorted before reloading.

If message HPSU3203I is issued and the root key field is compressed, specify the DECOMPRESS=YES option and rerun the job.

---

**HPSU3172E      RAPCHECK=YES IS NOT ALLOWED FOR THIS DATABASE**

## Explanation

RAPCHECK=YES is specified for a database that is not HDAM or PHDAM.

## System action

The IPR Unload utility ends abnormally.

## User response

Remove the RAPCHECK control statement or specify RAPCHECK=NO.

---

**HPSU3173E      HPSURPCX RECEIVED RC=xx FROM HDAM RANDOMIZER**

## Explanation

The RAPCHECK exit (HPSURPCX) received a return code xx (in hexadecimal) from the HDAM randomizer.

## System action

The IPR Unload utility ends abnormally.

## User response

Check the reason of the return code xx from the HDAM randomizer. Correct the error and rerun the job.

---

**HPSU3174E      OUTPUT STATEMENT IS SPECIFIED WITH RAPCHECK=YES**

## Explanation

The OUTPUT control statement cannot be specified with RAPCHECK=YES.

## System action

The IPR Unload utility ends abnormally.

## User response

If you want to activate the RAPCHECK option, remove the OUTPUT statement. If you want to deactivate the RAPCHECK option, remove the RAPCHECK control statement or specify RAPCHECK=NO.

---

**HPSU3201E      OPEN ERROR FOR //IMS DD**

## Explanation

The IMS DD data set could not be opened to read the IMS DBD control blocks at the initialization of IPR Unload utility.

## System action

The IPR Unload utility ends abnormally.

## User response

Provide correct DD statements. Check for additional error messages issued by the access method.

---

**HPSU3202E      UNLOAD FUNCTION ENCOUNTERED AN UNEXPECTED ERROR AT INITIALIZATION**

## Explanation

An unexpected error situation is encountered at the initialization of the Unload function. A possible reason could be a change of IMS DBD control blocks.

## System action

The IPR Unload utility ends abnormally.

## User response

Check that the correct DBDs, PSBs, and ACBs are used. If the cause of the error is not clear, contact IBM Software Support.

---

**HPSU3203I      COMPRESSED SEGMENTS WILL NOT BE DECOMPRESSED**

## Explanation

The IPR Unload utility was requested not to decompress compressed segments on the DECOMPRESS control statement. The output of IPR Unload utility might contain segments in a compressed format unless they are decompressed by an IPR Unload utility user exit routine.

## System action

The IPR Unload utility continues processing.

## User response

Make sure if the DECOMPRESS=NO option is acceptable.

---

**HPSU3205W COMPAREDLI OPTION CANNOT BE USED FOR THIS EXECUTION**

## Explanation

The IPR Unload utility encountered a condition that precludes the use of the compare option.

## System action

The IPR Unload utility deactivates the compare option.

## User response

None.

---

**HPSU3206E *statement* IS SPECIFIED FOR AN UNSUPPORTED DB TYPE**

## Explanation

The indicated control statement is not supported for this database type.

## System action

The IPR Unload utility ends abnormally.

## User response

Correct the control statement and rerun the IPR Unload job.

---

**HPSU3252E OUTPUT FORMAT \*CP IS NOT SUPPORTED FOR THIS DATABASE: DBD=*dbdname***

## Explanation

This message is issued if the \*CP format is specified for a database that is not a HALDB.

## System action

The IPR Unload utility ends abnormally.

## User response

Use an unload format other than \*CP for this database.

---

**HPSU3253I DFSURGU<sub>n</sub> DD IS USED INSTEAD OF SYSUT<sub>n</sub> DD**

## Explanation

The SYSUT<sub>n</sub> (n=2 or 3) DD statement is not specified. IPR Unload utility uses the DFSURGU<sub>n</sub> (n=1 or 2) DD statement instead of the SYSUT<sub>n</sub> (n=2 or 3) DD statement.

## System action

The IPR Unload utility continues processing.

## User response

None. This message is informational.

---

**HPSU3254E PIPE BLOCK SIZE IS TOO SMALL. MINIMUM PIPEBLKSZ IS *size***

## Explanation

The block size of IPRPIPE that is specified on the PIPEBLKSZ control statement is too small. *size* shows the value that is specified on the PIPEBLKSZ control statement.

## System action

The IPR Unload utility task ends abnormally.

## User response

Specify a larger value on the PIPEBLKSZ control statement so that the unloaded records can be processed. Rerun the job.

---

**HPSU3255E OUTPUT FORMAT \*CS IS NOT SUPPORTED FOR THIS DATABASE: DBD=*dbdname***

## Explanation

This message is issued if the \*CS format is specified for a SHISAM database or for a secondary index.

## System action

The IPR Unload utility ends abnormally.

## User response

Use an unload format other than CS for this database.

---

**HPSU3256E BLKSIZE OR LRECL OF *ddname* IS TOO SMALL**

## Explanation

The block size or the record size of the *ddname* data set is too small. For \*HD output, the block size is always the maximum device capacity. For

other output, the block size or the record size is the maximum device capacity unless a block size or record size is coded on the JCL statement.

### System action

The IPR Unload utility ends abnormally.

### User response

- If the utility uses the maximum device capacity, check if the *ddname* can be allocated on a device with more track capacity.
- If the utility uses the block size or the record size specified on the JCL statement, check if the block size or the record size can be increased or use the default maximum device capacity.
- Record size can be specified only for \*F1, \*F2, and \*F3 format. If the record size (LRECL) is coded on the JCL statement, it must be less than or equal to the block size minus 4.

---

**HPSU3257E      OPEN OF *ddname* HAS FAILED**

### Explanation

The IPR Unload utility could not open the *ddname* data set to unload the database.

### System action

The IPR Unload utility ends abnormally.

### User response

Correct the SYSUT2, SYSUT3, or SYSUT4 DD statement.

---

**HPSU3258E      INITIALIZATION OF UNLOAD  
FUNCTION IS NOT SUCCESSFUL**

### Explanation

The IPR Unload utility attempted to start the unload processing, but initialization was not successful.

### System action

The IPR Unload utility ends abnormally.

### User response

Correct the error and rerun the job.

---

**HPSU3259E      THE RECORD EDITED BY THE EXIT  
ROUTINE *xxxxxxx* IS TOO LONG**

### Explanation

A user exit routine *xxxxxxx* created an unload record that is larger than is allowed.

### System action

The IPR Unload utility ends abnormally.

### User response

Correct the routine.

---

**HPSU3260E      INVALID RETURN CODE FROM  
EXIT ROUTINE *xxxxxxx*, [RETURN  
CODE=*ccc* | RETURN CODE  
GREATER THAN 999]**

### Explanation

An incorrect return code (*ccc* or a value greater than 999) was returned from the user exit routine *xxxxxxx*. The return code can be one of the following values:

- For the Type-A user exit routine, 0, 4, 8, 12, 16, 256, 260, 264, 268, or 272.
- For the Type-B user exit routine, 0, 4, 8, 12, or a value in the range of 100 - 999.

### System action

The IPR Unload utility ends abnormally.

### User response

Correct the routine.

---

**HPSU3261E      OPEN OF SYSUT1 HAS FAILED**

### Explanation

The IPR Unload utility could not open SYSUT1.

### System action

The IPR Unload utility ends abnormally.

### User response

Correct the SYSUT1 DD statement.

---

**HPSU3262E      RECORDS OF SYSUT1 AND SYSUT2  
ARE NOT EQUAL**

### Explanation

The IPR Unload utility compared its SYSUT2 output with the output from the IMS HD Reorganization Unload utility (which was defined by the SYSUT1 DD

statement). The IPR Unload utility detected that these data sets contain records that are not equal.

### System action

The IPR Unload utility ends abnormally. In the dump, register 7 points to the SYSUT1 record and register 8 to the SYSUT2 record.

### User response

Run the IPR Unload utility with the HPSIN compare option and the trace option of HPSIN hard-copy.

### Problem determination

- Check if the database processed by the IPR Unload utility was being updated at that time.
- Check if the database and DBD have not been updated between the execution of IMS HD Reorganization Unload and the execution of the IPR Unload utility.
- Check if SYSUT1 is created with the IMS HD Reorganization Unload utility without any user exit routine.
- Check if the run of the IMS HD Reorganization Unload utility was successful.
- Save all output of the IMS HD Reorganization Unload utility.

---

**HPSU3263E      SYSUT1 CONTAINS MORE DATA RECORDS THAN SYSUT2**

### Explanation

The IPR Unload utility compared its SYSUT2 output with the output of the IMS HD Reorganization Unload utility (which was defined by the SYSUT1 DD statement). The IPR Unload utility detected that these data sets did not contain the same number of database segments.

### System action

The IPR Unload utility ends abnormally.

### User response

See message HPSU3262E for more information, and take an appropriate action.

---

**HPSU3264E      SYSUT1 CONTAINS LESS DATA RECORDS THAN SYSUT2**

### Explanation

The IPR Unload utility compared its SYSUT2 output with the output of the IMS HD Reorganization Unload utility (which was defined by the SYSUT1 DD statement). The IPR Unload utility detected that these data sets did not contain the same number of database segments.

### System action

The IPR Unload utility ends abnormally.

### User response

See message HPSU3262E for more information, and take an appropriate action.

---

**HPSU3265W      SIZE OF STATISTIC TABLES ARE NOT THE SAME IN SYSUT1 AND SYSUT2**

### Explanation

The IPR Unload utility compared its SYSUT2 output with the output of the IMS HD Reorganization Unload utility (which was defined by the SYSUT1 DD statement). The IPR Unload utility detected that the statistic tables stored in the first and last record do not have the same length.

### System action

IPR Unload utility continues processing.

### User response

Run the IPR Unload utility with the HPSIN compare option and the HPSIN hard-copy trace option.

### Problem determination

- Check if the DBD has not been updated between the execution of IMS HD Reorganization Unload and the execution of the IPR Unload utility.
- Check if SYSUT1 is created with the IMS HD Reorganization Unload utility without any user exit routines.
- Check if the run of the IMS HD Reorganization Unload utility was successful.
- Save all output of the IMS HD Reorganization Unload utility.

---

**HPSU3266W      COMPARE OF SYSUT1 AND SYSUT2 STOPPED**



## Explanation

The IPR Unload utility compared its SYSUT2 output with the output of the IMS HD Reorganization Unload utility. The IPR Unload utility stopped the comparison for one of the following reasons:

- Some segments are not sensitive.
- A user routine returned a nonzero return code.

## System action

The IPR Unload utility continues its processing without performing the comparison of SYSUT1 and SYSUT2 because the comparison is no longer possible.

## User response

None.

---

<b>HPSU3267E</b>	<b>GG STATUS CODE ENCOUNTERED AND SKIPERROR OPTION WAS NOT ACTIVATED</b>
------------------	--

## Explanation

The IPR Unload utility retrieve module detected a database error and returned a GG status-code to the IPR Unload utility. The database unload utility can handle this status-code only if the SKIPERROR option has been activated.

## System action

The IPR Unload utility ends abnormally.

## User response

To unload the damaged database, activate the SKIPERROR option.

## Problem determination

Check if the correct DBD was being used. Check if the database processed by the IPR Unload utility was being updated at that time.

---

<b>HPSU3268E</b>	<b>NOT ALL SEGMENTS WERE SENSITIVE</b>
------------------	--

## Explanation

The IPR Unload utility detected that some database segment types were not sensitive.

## System action

The IPR Unload utility ends abnormally.

## User response

See the problem determination and take an appropriate action. If necessary, contact IBM Software Support.

## Problem determination

Check if the correct DBD was being used.

---

<b>HPSU3269I</b>	<b>SOME SEGMENTS HAVE BEEN SKIPPED BY USER ROUTINE; EXIT=<i>exitname</i></b>
------------------	--

## Explanation

The IPR Unload utility detected that a user exit routine has set a nonzero return code, indicating that some segment occurrences must be skipped and must not be written to the specified output.

## System action

The IPR Unload utility continues processing.

## User response

Check if the user routines really should have set a nonzero return code.

---

<b>HPSU3270W</b>	<b>BLANKS ARE RETURNED IN VIRTUAL LPCK FIELD</b>
------------------	--

## Explanation

The IPR Unload utility detected that a logical child segment type has a virtual logical parent key. Hence, the output contains blanks instead of the concatenated logical parent key (unless user routines have performed additional processing).

## System action

The IPR Unload utility continues processing.

## User response

Check if this situation is acceptable. If not, specify BLDLPCK=YES and rerun the unload job.

---

<b>HPSU3271W</b>	<b>SEGMENTS MAY BE MISSING ON UNLOADED OUTPUT BECAUSE OF GG/GX STATUS CODE</b>
------------------	--

## Explanation

The IPR Unload utility is running with the SKIPERROR option in order to unload a database that contained

database errors. Some segments might be missing on the unloaded output.

### System action

The IPR Unload utility continues processing.

### User response

Check if the unloaded database version is acceptable to the applications.

### Problem determination

Check if the correct DBDs were being used. Check if the database processed by the IPR Unload utility was being updated at that time.

---

#### HPSU3273W COMPARE OF SYSUT1 AND SYSUT2 DEACTIVATED

### Explanation

The IPR Unload utility detected a SYSUT1 DD statement, but one of the following conditions was also detected:

- No SYSUT2 output
- Segment expansion option Y on the OUTPUT control statement
- Format type other than \*HD on the OUTPUT control statement
- DECOMPRESS=NO

The compare option cannot be used if one of these conditions exists.

### System action

The IPR Unload utility ignores the SYSUT1 DD statement and does not perform comparison of the SYSUT1 and SYSUT2. Processing continues.

### User response

Correct the OUTPUT or DECOMPRESS control statement, or do not specify the SYSUT1 DD statement.

---

#### HPSU3274E RETURN CODE 4 FROM HDAM RANDOMIZER, RMOD=xxxxxxx

### Explanation

The IPR Unload utility received a status code FM because of the return code 4 from the HDAM randomizing module. xxxxxxx is the name of HDAM randomizing module. Register 9 contains the address of the key used by the HSSR call.

### System action

The IPR Unload utility ends abnormally.

### User response

The randomizer is different from the one for the real database. Use the correct randomizer and rerun the JOB if necessary.

---

#### HPSU3275W NO SEGMENT WAS RETRIEVED

### Explanation

The IPR Unload utility attempted to unload a database, but no segment was retrieved from the database. The database might be empty.

### System action

The IPR Unload utility normally ends with a return code of 4.

### User response

Check if input database with no valid segments is acceptable. If an incorrect database data set or an incorrect DBD was specified, specify the correct value, and rerun the IPR Unload utility job.

---

#### HPSU3276E SYNTAX ERROR IN PARTITION STATEMENT: reason

### Explanation

An incorrect PARTITION statement is specified in the HPSIN data set. *reason* indicates the reason of the error as listed as follows:

#### *reason*

##### Description

#### NOT POSITIVE NUMBER

Zero or a negative number is not allowed for the second operand.

#### TOO MANY PARTNAMES

If \*ALL is specified once, no partition name can be specified. If the number of the partitions is specified in the second operand, two or more partition names cannot be specified. If a list of the partition names is specified, more than 1001 partition names cannot be specified.

### System action

The IPR Unload utility issues message HPSU3360E and ends with a return code of 8.

## User response

Correct the error, and rerun the IPR Unload utility job.

---

**HPSU3277E DDNAME NOT FOUND  
PARTITION=*ddname***

## Explanation

The *ddname* specified on a PARTITION control statement was not found within DBD.

## System action

The IPR Unload utility ends abnormally.

## User response

Correct the PARTITION control statement, and rerun the job.

---

**HPSU3278I NOT ALL PARTITIONS ARE  
PROCESSED**

## Explanation

This message is for information only. This message notifies the user that all partitions are not processed by the IPR Unload utility job. Only the selected partitions are processed.

## System action

The IPR Unload utility continues processing.

## User response

None. This message is informational.

---

**HPSU3279E 'DATA CONVERSION' OPTION FOR  
OUTPUT CONTROL STATEMENT IS  
NOT ALLOWED**

## Explanation

The data conversion option of the OUTPUT control statement in the HPSIN data set is specified as YES (or Y), but DATXEXIT=YES is not specified in the HPSIN data set. This message is also issued if DATXEXIT=YES is specified in one of the following cases:

- DATXEXIT=YES is not specified in DBDGEN, and DFSDBUX1 is not found in any STEPLIB-concatenated libraries.
- DATXEXIT=YES is not specified in DBDGEN, and DFSDBUX1 returned X' FF' in SRCHFLAG.

In either case, the data conversion exit is deactivated and the data conversion option in the OUTPUT control statement becomes meaningless.

## System action

The IPR Unload utility ends with a return code of 8 in the former case. The IPR Unload utility ends abnormally ends in the latter case.

## User response

Determine if you need a data conversion exit routine to be called in your IPR Unload utility job. If you do, prepare an appropriate DFSDBUX1 module in a STEPLIB-concatenated library, specify DATXEXIT=YES in the HPSIN data set, and then rerun the job. If it is not needed, specify NO for the data conversion option of the OUTPUT control statement, and remove the DATXEXIT=YES statement from the HPSIN data set.

---

**HPSU3280I *nnn,nnn,nnn* DB RECORDS  
RETRIEVED - DBD=*dbdname*  
PART=*ddname***

## Explanation

*nnn,nnn,nnn* database records have been retrieved from database *dbdname*. PART=*ddname* is displayed only for partitioned databases, and in that case, the database records are counted per partition. This information message enables you to monitor the IPR Unload utility job progress.

## System action

The IPR Unload utility continues processing.

## User response

None. This message is informational.

---

**HPSU3281E ERROR IN PARTITION  
STATEMENT: *reason***

## Explanation

An incorrect PARTITION statement is specified in the HPSIN data set. *reason* indicates the reason of the error listed as follows:

### *reason*

#### Description

#### **NON-PARTITIONED DB**

The PARTITION control statement is specified for a nonpartitioned database.

#### **TOO LONG NAME**

The specified name is too long for a partition name.

### THE NUMBER IS TOO LARGE

The number of partitions, specified as the second operand, is larger than what is allowed for the database.

#### System action

The IPR Unload utility ends abnormally.

#### User response

Correct the error and rerun the job.

---

**HPSU3282E NUMBERS IN DBRECDIST STATEMENTS MUST BE SPECIFIED IN ASCENDING ORDER**

#### Explanation

The range values specified in DBRECDIST control statements must not be duplicated and must be in ascending order.

#### System action

The IPR Unload utility issues message HPSU3360E and ends its processing.

#### User response

Correct the error and rerun the job.

---

**HPSU3283E MORE THAN 20 RANGE VALUES ARE SPECIFIED**

#### Explanation

More than 20 range values are specified in the DBRECDIST control statements.

#### System action

The IPR Unload utility issues message HPSU3360E and ends its processing.

#### User response

Reduce the number of DBRECDIST control statements, and rerun the job.

---

**HPSU3284E INVALID DBRECDIST STATEMENT IS SPECIFIED**

#### Explanation

The IPR Unload utility detected an incorrect DBRECDIST control statement.

#### System action

The IPR Unload utility issues message HPSU3360E and ends its processing.

#### User response

If you do not want to generate the Distribution of Database Record Sizes report, specify only 0 in the DBRECDIST control statement. If you want to generate it, specify—up to 20—a value other than 0 (a decimal number in the range of 1 - 9999999) in the DBRECDIST control statement. For how to specify the DBRECDIST control statement, see “[DBRECDIST control statement](#)” on page 370.

---

**HPSU3285E xxx PARAMETER IS TOO LOW; MINIMUM IS 1**

#### Explanation

The xxx parameter is lower than the acceptable minimum value 1.

#### System action

The IPR Unload utility issues message HPSU3360E and ends its processing.

#### User response

Correct the xxx parameter of the HOMECHK control statement.

---

**HPSU3286E xxx PARAMETER IS TOO HIGH; MAXIMUM IS 998**

#### Explanation

The xxx parameter is higher than the acceptable maximum value 998.

#### System action

The IPR Unload utility issues message HPSU3360E and ends its processing.

#### User response

Correct the xxx parameter of the HOMECHK control statement.

---

**HPSU3287E INVALID HOMECHK STATEMENT IS SPECIFIED**

## Explanation

The IPR Unload utility detected an incorrect HOMECHK control statement.

## System action

The IPR Unload utility issues message HPSU3360E and ends its processing.

## User response

If you do not want to generate the HDAM Root Placement section in the HDAM Root Addressable Area Statistics report, specify 0 in the HOMECHK control statement. If you want to generate it, specify (-*mmm*,+*nnn*), where *mmm* and *nnn* are decimal numbers in the range of 1 - 998.

---

<b>HPSU3288E</b>	<b>MORE THAN 255 SEGMENT NAMES ARE SPECIFIED</b>
------------------	--

## Explanation

More than 255 segment names are specified in the SEGSEL control statements.

## System action

The IPR Unload utility issues message HPSU3360E and ends its processing.

## User response

Reduce the number of segment names in the SEGSEL control statements, and rerun the job.

---

<b>HPSU3289E</b>	<b>DUPLICATE SEGMENT NAMES ARE SPECIFIED</b>
------------------	--

## Explanation

The IPR Unload utility detected duplicate segment names on the SEGSEL control statement.

## System action

The IPR Unload utility issues message HPSU3360E and ends its processing.

## User response

Correct the control statement, and rerun the job.

---

<b>HPSU3290E</b>	<b>SEGMENT NAME <i>segmname</i> IS NOT FOUND IN DBD=<i>dbdname</i></b>
------------------	--

## Explanation

The segment name *segmname* specified on the SEGSEL control statement is not found in the DBD *dbdname*. If it is the virtual logical child segment, this message is issued.

## System action

The IPR Unload utility ends abnormally.

## User response

Correct the segment name and rerun the job.

---

<b>HPSU3291E</b>	<b>DUPLICATE PARTITION NAMES SPECIFIED</b>
------------------	--

## Explanation

The IPR Unload utility detected duplicate partition names on one or more PARTITION control statements.

## System action

The IPR Unload utility issues message HPSU3360E and ends with a return code of 8.

## User response

Correct the error, and rerun the IPR Unload utility job.

---

<b>HPSU3292E</b>	<b>AUTHORIZATION FAILURE OCCURRED IN DBDNAME=<i>dbdname</i></b>
------------------	---

## Explanation

Under Smart Reorg, the IPR Unload utility task received an error return code from the IMS authorization module DFSDBAU0 for database *dbdname*.

## System action

The IPR Unload utility ends abnormally.

## User response

Make sure that the database is authorized before reorganization.

---

<b>HPSU3350W</b>	<b>NO OUTPUT CONTROL STATEMENT SPECIFIES *UH FORMAT</b>
------------------	---

## Explanation

Even though USERHDR control statement was specified, there is no OUTPUT control statement that specifies the \*UH format.

## System action

The IPR Unload utility ignored the USERHDR control statement and continued the processing.

## User response

If you want to validate the specification of the USERHDR control statement, specify the OUTPUT control statement that specifies the \*UH format.

---

<b>HPSU3351E</b>	<b>MORE THAN 22 ELEMENTS ARE SPECIFIED IN USERHDR</b>
------------------	---

## Explanation

More than 22 elements are specified on the USERHDR control statements.

## System action

Processing stops.

## User response

Reduce the number of elements on the USERHDR control statements, and rerun the job.

---

<b>HPSU3352E</b>	<b>DUPLICATE ELEMENT (<i>element</i>) SPECIFIED IN USERHDR CONTROL STATEMENT</b>
------------------	--

## Explanation

The keyword *element* is specified more than once on the USERHDR control statement. The *element* can be specified only once.

## System action

Processing stops.

## User response

Correct the parameter error, and rerun the job.

---

<b>HPSU3353E</b>	<b>INCORRECT KEYWORD ON USERHDR STATEMENT WAS DETECTED</b>
------------------	--

## Explanation

The IPR Unload utility detected an undefined keyword on the USERHDR control statement.

## System action

The IPR Unload utility issues message HPSU3360E and ends its processing.

## User response

Correct the USERHDR control statement.

## Problem determination

See the “USERHDR control statement” on page 387.

---

<b>HPSU3354E</b>	<b>USERHDR CONTROL STATEMENT IS REQUIRED FOR *UH FORMAT</b>
------------------	---

## Explanation

The \*UH format is specified on the OUTPUT control statement, however, there is no USERHDR control statement.

## System action

The IPR Unload utility issues message HPSU3360E and ends its processing.

## User response

Specify the USERHDR control statement.

---

<b>HPSU3359E</b>	<b>THIS STATEMENT IS NOT ALLOWED IN xxxxxxxx FUNCTION</b>
------------------	---

## Explanation

The control statement printed just before the message is not allowed in xxxxxxxx function of the IPR Unload utility. The string xxxxxxxx shows IPR Unload utility's function that has been activated.

## System action

The IPR Unload utility issues message HPSU3360E. The IPR Unload utility then ends with a return code of 8 or abends, depending on the function that had been activated.

## User response

Remove the control statement in error and rerun the job.

---

<b>HPSU3360E</b>	<b>INVALID STATEMENT IN HPSIN DD WAS DETECTED</b>
------------------	---

## Explanation

The control statement analyzer of the IPR Unload utility detected an incorrect HPSIN control statement.

### System action

For unload function and DB scan function, the IPR Unload utility ends with return code of 8; for API function, the IPR Unload utility issues a user abend.

### User response

Correct the control statement.

---

**HPSU3361E      INVALID KEYWORD ON TRACE STATEMENT WAS DETECTED**

### Explanation

The IPR Unload utility detected an undefined keyword on the HPSIN 'TRACE' control statement.

### System action

The IPR Unload utility issues message HPSU3360E and ends its processing.

### User response

Correct the TRACE control statement.

### Problem determination

Only the following keywords are permitted:

CALL  
NPF  
CB  
CBX  
BUF  
BUFCB  
*nnn* (the call number)

---

**HPSU3366E      INVALID DBSTATS STATEMENT IS SPECIFIED**

### Explanation

The IPR Unload utility detected an incorrect HPSIN DBSTATS control statement.

### System action

The IPR Unload utility issues message HPSU3360E and ends its processing.

### User response

Correct the DBSTATS control statement.

---

**HPSU3368E      INVALID APISET CONTROL STATEMENT IS SPECIFIED**

### Explanation

An incorrect operand is specified for the APISET control statement in the HPSIN data set. The operand must be one of 1, 2, and 3.

### System action

The IPR Unload utility issues message HPSU3360E and ends its processing.

### User response

Correct the APISET control statement.

---

**HPSU3369E      xxxxxxxx CANNOT BE ACTIVATED WHEN APISET=3 IS SELECTED**

### Explanation

The xxxxxxxx option is not supported for APISET=3.

### System action

The IPR Unload utility issues message HPSU3360E and ends its processing.

### User response

Deactivate the xxxxxxxx option or specify APISET=1 or 2.

---

**HPSU3370E      INVALID PCBLIST CONTROL STATEMENT IS SPECIFIED**

### Explanation

An incorrect operand is specified for the PCBLIST control statement in the HPSIN data set. The operand must be HSSR or IMS.

### System action

The IPR Unload utility issues message HPSU3360E and ends its processing.

### User response

Correct the PCBLIST control statement.

---

**HPSU3371E      INVALID CABBASE CONTROL STATEMENT IS SPECIFIED**

### Explanation

An incorrect operand is specified for the CABBASE control statement in the HPSIN data set.

## System action

The IPR Unload utility issues message HPSU3360E and ends its processing.

## User response

Correct the CABBASE control statement.

---

<b>HPSU3375E</b>	<b>INVALID KEYCHECK STATEMENT IS SPECIFIED</b>
------------------	--

## Explanation

The IPR Unload utility detected an incorrect HPSIN KEYCHECK control statement.

## System action

The IPR Unload utility issues message HPSU3360E and ends its processing.

## User response

Correct the KEYCHECK statement.

---

<b>HPSU3376E</b>	<b>INVALID KEYWORD ON DIAGG STATEMENT WAS DETECTED</b>
------------------	--

## Explanation

The IPR Unload utility detected an undefined keyword on the DIAGG control statement.

## System action

The IPR Unload utility issues message HPSU3360E and ends its processing.

## User response

Correct the DIAGG statement.

---

<b>HPSU3380E</b>	<b>HPSCLI00 IS NOT FOUND ALTHOUGH DECODEDBD=YES SPECIFIED</b>
------------------	---

## Explanation

Although DECODEDBD=YES is specified, the required module HPSCLI00 is not found.

## System action

The IPR Unload utility issues user abend 3380.

## User response

If you want to use DECODEDBD=YES, make sure that the required maintenance has been applied to IMS Database Reorganization Expert. Otherwise, remove the DECODEDBD control statement and rerun the job.

---

<b>HPSU3551I</b>	<b>OUTPUT REPOSITORY PROCESSING IS TERMINATED</b>
------------------	---

## Explanation

This is an information message showing that the connection to IMS Tools KB Output Repository is ended.

## System action

The IPR Unload utility continues processing.

## User response

None. This message is informational.

---

<b>HPSU3555W</b>	<b>GETMAIN FAILED FOR ITKB TEMPORARY WORK STORAGE</b>
------------------	---

## Explanation

An error occurred in the GETMAIN macro to obtain the temporary work storage.

## System action

The IPR Unload utility continues processing. Some of reports will not be stored in the IMS Tools KB Output repository.

## User response

Make sure that sufficient virtual storage is available.

---

<b>HPSU3556I</b>	<b>APF AUTHORIZATION CHECK FAILED (DD: <i>ddname</i>, REASON: <i>nn</i>)</b>
------------------	--

## Explanation

The APF-authorization check module (HPSUAPF0) returned an error for the *ddname* DD statement. The reason code *nn* is used by the module internally.

## System action

The IPR Unload utility continues processing.

## User response

This error is likely an internal system error. Contact IBM Software Support.



---

**HPSU3561W THE ACCESS TO OUTPUT REPOSITORY WAS CANCELED.**  
**REASON: *reason***

### Explanation

IPR Unload utility canceled its access to the IMS Tools KB Output Repository because the initialization process failed. The reason is one of the following:

**Reason**  
**Meaning**

#### **ITKBLOAD DYNALLOC FAILURE**

Dynamic allocation for the library specified in the ITKBLOAD control statement failed.

#### **HKTXXLI LOAD FAILURE**

Loading of the HKTXXLI module failed.

#### **ITKBLOAD OPEN FAILURE**

Opening of the library specified in the ITKBLOAD control statement failed.

#### **ITKBLOAD NOT AUTHORIZED**

Library specified in the ITKBLOAD control statement is not APF-authorized.

### System action

Processing continues, but no reports are stored to the IMS Tools KB Output repository.

### User response

If you want to store reports to the IMS Tools KB Output repository, specify the IMS Tools KB product load module library correctly. If the reason is "ITKBLOAD NOT AUTHORIZED", the library must be APF-authorized.

---

**HPSU3562W ERROR OCCURRED IN ACCESSING OUTPUT REPOSITORY FUNC:**  
***function RC: rc RSN: rsn***

### Explanation

An error occurred while getting access to the IMS Tools KB Output repository.

### System action

Processing continues. If the return code is equal to or greater than 08, no reports are stored to the IMS Tools KB Output repository.

### User response

If you want to store the reports to the IMS Tools KB Output repository, correct the error. If any of the messages, HPSU3580W, HPSU3581W, HPSU3582W,

or HPSU3583W, which describes the cause of the error, are issued following this message, see the explanation for those messages. If these messages are not issued, check the return code *rc* and the reason code *rsn*. The codes are in hexadecimal. For the description of the codes, see the *IMS Tools Base IMS Tools Knowledge Base User's Guide and Reference*.

---

**HPSU3563W ERROR OCCURRED IN ACCESSING OUTPUT REPOSITORY FUNC:**  
***function RC: rc RSN: rsn***

### Explanation

An error occurred while getting access to the IMS Tools KB Output repository.

### System action

Processing continues. If the return code is equal to or greater than 08, the report shown in the HPSU3564W message and the following reports are not stored in the IMS Tools KB Output repository.

### User response

See the description for the HPSU3562W message.

---

**HPSU3564W DBD: *dbdname* PART: *partname***  
**REPORT: *report-name***

### Explanation

This message follows the HPSU3563W message to show which report is processed.

### System action

See the description for the HPSU3563W message.

### User response

See the description for the HPSU3563W message.

---

**HPSU3565I THE ITKBLOAD PARAMETER WAS IGNORED BECAUSE HKTLOAD DD NAME WAS SPECIFIED**

### Explanation

An IMS Tools KB load module data set name was specified for the ITKBLOAD parameter, but the specification was ignored because HKTLOAD DD statement was specified in the IPR Unload utility JCL.

## System action

Processing continues. IPR Unload utility loads the IMS Tools KB load module from the HKTLOAD DD statement.

## User response

None. This message is informational.

---

**HPSU3570W RECON ENTRY WAS NOT FOUND IN ITKB**

## Explanation

The RECON entry was not found in your IMS Tools KB information management environment.

## System action

Processing continues, but no reports are stored to the IMS Tools KB Output repository.

## User response

If you want to store reports to the IMS Tools KB Output repository, add a RECON environment. For more information about adding the RECON environment, see the *IMS Tools Base IMS Tools Knowledge Base User's Guide and Reference* or the *IMS Tools Base Configuration Guide*.

---

**HPSU3571W ITKB SERVER NAME WAS INCORRECT**

## Explanation

The connection to the IMS Tools KB server failed because the server XCF group name specified by the ITKBSVR control statement was incorrect.

## System action

Processing continues, but no reports are stored to the IMS Tools KB Output repository.

## User response

If you want to store reports to the IMS Tools KB Output repository, specify the correct IMS Tools KB server XCF group name.

---

**HPSU3572W THE PRODUCT HP UNLOAD WAS NOT DEFINED IN ITKB**

## Explanation

IMS HP Unload was not defined in the IMS Tools KB information management environment as a product

that can store reports to the IMS Tools KB Output repository.

## System action

Processing continues, but no reports produced by IMS HP Unload are stored to the IMS Tools KB Output repository.

## User response

If you want to store reports to the IMS Tools KB Output repository, register the IMS HP Unload product by the IMS Tools KB product administration utility. For more information, see the *IMS Tools Base IMS Tools Knowledge Base User's Guide and Reference* or the *IMS Tools Base Configuration Guide*.

---

**HPSU3573W THE REPORT WAS NOT DEFINED IN ITKB**

## Explanation

The report was not defined in the IMS Tools KB information management environment.

## System action

Processing continues, but the report is not stored to the IMS Tools KB Output repository.

## User response

If you want to store the report to the IMS Tools KB Output repository, register the report by using the IMS Tools KB product administration utility. For more information, see the *IMS Tools Base IMS Tools Knowledge Base User's Guide and Reference* or the *IMS Tools Base Configuration Guide*.

---

**HPSU3601E PARAMETER ERROR DETECTED ON PARM: parm\_string**

## Explanation

An incorrect parameter is detected. The incorrect parameter string is listed as *parm\_string*.

## System action

The IPR Unload utility issues user abend 3601.

## User response

Correct the parameter error, and rerun the job.

## Problem determination

Check the parameter specification listed as *parm\_string*.

---

**HPSU3610E**      **OPEN FAILED FOR DDNAME:**  
*ddname*

## Explanation

After an OPEN macro was issued to open the non-VSAM data set associated with *ddname*, DCBOFLGS was not zero.

## System action

The IPR Unload utility issues user abend 3610.

## User response

Correct the error and rerun the job.

## Problem determination

Make sure that the DD statement associated with *ddname* indicates the correct data set.

---

**HPSU3611E**      **BLDL MACRO FAILED FOR**  
**MEMBER *mbrname* IN LIBRARY**  
***ddname* (RC=*rc*, RSN=*rsn*)**

## Explanation

The BLDL macro failed for member *mbrname* in the library that has the DD name *ddname*. The return code from the macro call was *rc*, and the reason code was *rsn*.

## System action

The IPR Unload utility issues user abend 3611.

## User response

This error is likely an internal system error. Contact IBM Software Support.

---

**HPSU3612E**      **ERROR RETURN FROM IGWASYS**  
**(RC=*xx*, RSN=*yy*)**

## Explanation

The IPR Unload utility called IGWASYS, but an error return code was returned from IGWASYS. *xx* is the return code and *yy* is the reason code.

## System action

The IPR Unload utility issues user abend 3612.

## User response

See *z/OS DFSMSdftp Advanced Services* and check the meaning of the return code and reason code.

---

**HPSU3613E**      **RDJFCB MACRO FAILED ON**  
**DDNAME: *ddname* (RC=*rc*)**

## Explanation

The RDJFCB macro failed for DD name *ddname*. The return code from the macro call was *rc*.

## System action

The IPR Unload utility issues user abend 3613.

## User response

This error is likely an internal system error. Contact IBM Software Support.

---

**HPSU3614E**      **UNKNOWN ERROR OCCURRED IN**  
***module-name* MODULE (CC=*xxx*)**

## Explanation

An internal error occurred in module *module-name* of the IPR Unload utility.

## System action

The IPR Unload utility issues user abend 3614.

## User response

Save the entire listing (including the dump, JCL, and reports) and contact IBM Software Support.

---

**HPSU3620E**      **DYNAMIC ALLOCATION FAILURE**  
**OCCURRED FOR DB: *dbdname* DD:**  
***ddname*. RC=*xx* RSN=*yyyy***

## Explanation

An attempt of dynamic allocation for *ddname* of *dbdname* failed. *xx* is the return code in register 15 and *yyyy* is the associated hexadecimal reason code from the SVC99 routine.

## System action

The IPR Unload utility issues user abend 3620.

## User response

Correct the error and rerun the job.

## Problem determination

The return code and reason code from the SVC99 routine is explained in the *z/OS MVS Authorized Assembler Services Guide*.

---

**HPSU3621E**      **DYNAMIC ALLOCATION (/ DEALLOCATION) FAILED FOR DDNAME=ddname RC=rc RSN=rsn**

### Explanation

An attempt to dynamically allocate or deallocate the data set that is identified by the DD name *ddname* failed. The values *rc* and *rsn* are the decimal return code and the hexadecimal reason code of the DYNALLOC macro.

### System action

The IPR Unload utility abends with a completion code of U3621.

### User response

Correct the error and rerun the job. If the error cannot be resolved, retain the dump that was produced at the time of error and contact IBM Software Support.

## Problem determination

For the return code and the reason code from the DYNALLOC macro, see the *z/OS MVS Authorized Assembler Services Guide*.

---

**HPSU3622E**      **DYNALLOC SERVICE FAILED: FUNC=funcname DDNAME=ddname RC=rc RSN=rsn**

### Explanation

An internal error occurred in the dynamic allocation service of IMS Database Reorganization Expert. Keyword *funcname* is INIT, ALLOC, SYSOUT, UNALLOC, or TERM.

### System action

The IPR Unload utility abends with a completion code of U3622.

### User response

This error is likely an internal system error. Retain the dump that was produced at the time of error and contact IBM Software Support.

---

**HPSU3626I**      **TERMINATION REQUESTED BY TYPE-B USER EXIT ROUTINE, RETURN CODE=nnn**

### Explanation

Job step termination was requested by the Type-B user exit routine. The routine returned the return code *nnn*.

### System action

The IPR Unload utility ends with the return code passed from the routine.

### User response

None. This message is informational.

---

**HPSU3627E**      **EXIT ROUTINE xxxxxxxx RETURNED RC=16 ALTHOUGH PARTITION AND COMPAREDLI STATEMENTS ARE SPECIFIED**

### Explanation

The user exit routine *xxxxxxx* returned a return code of 16 when both the PARTITION and COMPAREDLI control statements are specified for the Unload function of the IPR Unload utility. Exit routines must not return a return code of 16 when both of these statements are specified.

### System action

The IPR Unload utility ends abnormally.

### User response

Remove the COMPAREDLI or PARTITION statement from the HPSIN data set.

---

**HPSU3628E**      **EXIT ROUTINE xxxxxxxx RETURNED RC=256+ FOR THE VARIABLE-LENGTH SEGMENT sssssss**

### Explanation

A return code that is larger than or equal to 256 was returned from the exit routine *xxxxxxx* for the variable length segment *sssssss*. The return codes larger than or equal to 256 is valid only for fixed-length segments.

### System action

The IPR Unload utility ends abnormally.

## User response

Correct the routine.

---

<b>HPSU3629E</b>	<b>EXIT ROUTINE xxxxxxxx RETURNED RC=256+ FOR THE SEGMENT ssssssss</b>
------------------	--

---

## Explanation

A return code that is larger than or equal to 256 was returned from the exit routine xxxxxxxx for the segment ssssssss. The return codes larger than or equal to 256 is not allowed in parallel reorganization.

## System action

The Unload task in the parallel reorganization job ends abnormally.

## User response

Correct the routine, or use the routine in a stand-alone IPR Unload utility job.

---

<b>HPSU3630E</b>	<b>WORK AREA FOR TYPE-B USER EXIT <i>user_exit</i> IS TOO LARGE</b>
------------------	---

---

## Explanation

The size of the work area required by the Type-B user exit exceeds the size of the work area prepared by the IPR Unload utility.

## System action

The IPR Unload utility ends abnormally with a dump.

## User response

Reduce the size of the work area defined in the Type-B user exit. The size must be equal to or slightly larger than the maximum segment length.

---

<b>HPSU3631E</b>	<b>LOAD FAILED FOR MODULE: <i>module</i></b>
------------------	--

---

## Explanation

Load failed for the indicated module.

## System action

The IPR Unload utility ends abnormally with a dump.

## User response

Check the contents of the load module library. Correct the error and rerun the job.

---

<b>HPSU3632E</b>	<b>CEEPIPI ERROR OCCURRED. FUNC=<i>function</i>, RC=<i>return_code</i></b>
------------------	--

---

## Explanation

The IPR Unload utility invoked the Language Environment CEEPIPI service, but the CEEPIPI service returned a non-zero return code.

## System action

The IPR Unload utility ends abnormally with a dump.

## User response

When *function* shows INIT, the function of CEEPIPI is *init\_sub* or *identify\_entry*. When *function* shows CALLSUB, the function of CEEPIPI is *call\_sub*. For the return codes, see the topic about preinitialization services in the *Language Environment Programming Guide*.

Correct the error and rerun the job.

---

<b>HPSU3633E</b>	<b>LE OPTION IS NOT ALLOWED WHEN THE RUN TIME ENVIRONMENT EXIT ROUTINE IS BEING INVOKED</b>
------------------	---

---

## Explanation

If the RTEEXIT control statement is specified for a user runtime environment exit routine, the language environment option cannot be specified for the OUTPUT control statement to activate the Language Environment.

## System action

The IPR Unload utility ends abnormally with a dump.

## User response

Remove the RTEEXIT control statement and rerun the job.

---

<b>HPSU3670E</b>	<b>OUTPUT FORMAT *SH IS NOT ALLOWED FOR A DATABASE IN A LOGICAL RELATIONSHIP</b>
------------------	--

---

## Explanation

The short header (SH) format is not allowed for a database in a logical relationship.

## System action

The IPR Unload utility ends abnormally.

## User response

Specify a different unload format. If you want to reorganize a database in a logical relationship, you must use the HD format.

---

### HPSU3736E GETMAIN FAILED

## Explanation

This was caused by insufficient virtual storage in the address space.

## System action

The IPR Unload utility ends abnormally with a dump.

## User response

Make sure that sufficient virtual storage is available.

---

### HPSU3848E FAILED IN LOADING THE EXIT ROUTINE (xxxxxxx) SPECIFIED ON nnn OUTPUT STATEMENT (nnn: 1ST, 2ND or 3RD)

## Explanation

The IPR Unload utility failed in loading the exit routine xxxxxxx specified on the OUTPUT control statement.

## System action

The IPR Unload utility ends abnormally.

## User response

Check if the routine exists in a STEPLIB or a JOBLIB library. Specify the correct library, and rerun the job.

---

### HPSU3849E INVALID OUTPUT TYPE IS SPECIFIED

## Explanation

The IPR Unload utility detected an incorrect output type on the OUTPUT control statement. Only SYSUT2, SYSUT3, or SYSUT4 can be specified. DFSURGU1 and DFSURGU2 are also allowed.

## System action

The IPR Unload utility issues message HPSU3360E and ends its processing.

## User response

Correct the control statement.

---

### HPSU3850E DUPLICATE OUTPUT TYPES SPECIFIED

## Explanation

The IPR Unload utility detected a duplicate output type on the OUTPUT control statement.

## System action

The IPR Unload utility issues message HPSU3360E and ends its processing.

## User response

Correct the control statement.

---

### HPSU3851E INVALID OUTPUT FORMAT IS SPECIFIED

## Explanation

The IPR Unload utility detected an incorrect format type on the OUTPUT control statement.

## System action

The IPR Unload utility issues message HPSU3360E and ends its processing.

## User response

Correct the control statement. For the format types that are allowed, see [“OUTPUT control statement”](#) on page 375.

---

### HPSU3853E SEGMENT EXPAND LENGTH IS TOO HIGH; MAXIMUM IS 32767

## Explanation

The value of the segment expand length on the OUTPUT control statement is higher than the acceptable maximum.

## System action

The IPR Unload utility issues message HPSU3360E and ends its processing.

## User response

Correct the control statement.

---

### HPSU3855W SEGMENT EXPAND LENGTH CAN NOT BE USED FOR THIS EXECUTION

## Explanation

The segment expand length (*ext\_len*) was specified on the OUTPUT= control statement, but NO was specified for segment expand (*ext*) option.

## System action

The IPR Unload utility continues processing; the segment expand length is ignored.

## User response

Correct the control statement.

---

<b>HPSU3862E</b>	<b>NON-ZERO RC (xx) RETURNED FROM CONV EXIT</b>
------------------	---

## Explanation

A nonzero return code *xx* was returned from the DFSDBUX1 exit routine.

## System action

The IPR Unload utility ends abnormally.

## User response

Correct the error and rerun the job.

---

<b>HPSU3871E</b>	<b>USER EXIT TYPE MUST BE EITHER A OR B</b>
------------------	---

## Explanation

The user exit type specified on the OUTPUT control statement must be either A or B.

## System action

The IPR Unload utility issues message HPSU3360E and ends processing.

## User response

Correct the control statement and rerun the job.

---

<b>HPSU3873E</b>	<b>ONLY ONE OUTPUT STATEMENT IS ALLOWED WHEN TYPE-B USER EXIT IS USED</b>
------------------	---

## Explanation

If a Type-B user exit routine is specified on an OUTPUT control statement, no other OUTPUT control statement can be specified.

## System action

The IPR Unload utility issues message HPSU3360E and ends processing.

## User response

Correct the control statement and rerun the job.

---

<b>HPSU3901E</b>	<b>OPEN FAILED FOR DDNAME: <i>ddname</i></b>
------------------	--

## Explanation

After an OPEN macro was issued to open the non-VSAM data set associated with *ddname*, DCBOFLGS was not zero.

## System action

The IPR Unload utility ends abnormally.

## User response

Correct the error and rerun the job.

## Problem determination

Check that if a *ddname* DD statement is specified in the JCL stream. If one is specified, make sure that the DD statement indicates the correct data set.

---

<b>HPSU3902E</b>	<b>CONTROL STATEMENT SYNTAX ERROR</b>
------------------	---

## Explanation

An incorrect control statement was detected by the control statement syntax checking.

## System action

The IPR Unload utility issues message HPSU3360E and ends its processing.

## User response

Correct the error and rerun the job.

## Problem determination

Check the control statement.

---

<b>HPSU3903E</b>	<b>INVALID PARAMETER SPECIFIED: <i>parm_string</i></b>
------------------	--

## Explanation

An incorrect parameter is detected. The incorrect parameter string is listed as *parm\_string*.

### System action

The IPR Unload utility issues message HPSU3360E and ends its processing.

### User response

Correct the parameter error, and rerun the job.

### Problem determination

Check the parameter specification listed as *parm\_string*.

---

<b>HPSU3904E</b>	<b>NUMBER OF <i>parm_name</i> PARAMETERS EXCEEDED THE LIMIT: <i>nnn</i></b>
------------------	---

### Explanation

An incorrect control statement was detected by the control statement syntax checking.

### System action

The IPR Unload utility issues message HPSU3360E and ends its processing.

### User response

Correct the error and rerun the job.

### Problem determination

Check the control statement.

---

<b>HPSU3905E</b>	<b>NUMBER OF OPERANDS FOR <i>parm_name</i> PARAMETER EXCEEDED THE LIMIT: <i>nnn</i></b>
------------------	---

### Explanation

An incorrect control statement was detected by the control statement syntax checking.

### System action

The IPR Unload utility issues message HPSU3360E and ends its processing.

### User response

Correct the error and rerun the job.

### Problem determination

Check the control statement.

---

<b>HPSU3906E</b>	<b>LENGTH ERROR IN <i>N-th</i> OPERAND OF PARAMETER: <i>parm_name</i></b>
------------------	---

### Explanation

An incorrect control statement was detected by the control statement syntax checking.

### System action

The IPR Unload utility issues message HPSU3360E and ends its processing.

### User response

Correct the error and rerun the job.

### Problem determination

Check the control statement.

---

<b>HPSU3907E</b>	<b>ATTRIBUTE ERROR IN <i>N-th</i> OPERAND OF PARAMETER: <i>parm_name</i></b>
------------------	--

### Explanation

An incorrect control statement was detected by the control statement syntax checking.

### System action

The IPR Unload utility issues message HPSU3360E and ends its processing.

### User response

Correct the error and rerun the job.

### Problem determination

Check the control statement.

---

<b>HPSU3908E</b>	<b>NUMBER OF VALUES FOR <i>N-th</i> OPERAND EXCEEDED THE LIMIT: <i>nnn</i></b>
------------------	--

### Explanation

An incorrect control statement was detected by the control statement syntax checking.

### System action

The IPR Unload utility issues message HPSU3360E and ends its processing.

### User response

Correct the error and rerun the job.



### Problem determination

Check the control statement.

---

**HPSU3909E**      ***N-th* OPERAND IS REQUIRED FOR  
PARAMETER: *parm\_name***

### Explanation

An incorrect control statement was detected by the control statement syntax checking.

### System action

The IPR Unload utility issues message HPSU3360E and ends its processing.

### User response

Correct the error and rerun the job.

### Problem determination

Check the control statement.

---

**HPSU3910I**      **BLANK RECORD IN DDNAME:  
HPSIN**

### Explanation

A blank line is read in the HPSIN data set.

### System action

Processing continues.

### User response

None. This message is informational.



---

## Chapter 50. Diagnostics Aid

If you have a problem that you think is not a user error, use the Diagnostics Aid to collect the necessary information before you contact IBM Software Support.

1. Run IMS Database Reorganization Expert Diagnostics Aid (HPSCDIAG) and obtain the IMS Database Reorganization Expert Load Module APAR Status report.
2. Attach the report to the other diagnostic documents (such as job dump list or I/O of the utility).
3. Report the error to IBM.

IMS Database Reorganization Expert Diagnostics Aid (HPSCDIAG) generates the IMS Database Reorganization Expert Load Module APAR Status report for the IMS Database Reorganization Expert maintenance by IBM. This report shows the latest APAR fixes applied to each module and macro of IMS Database Reorganization Expert components.

### Topics:

- [“How to run Diagnostics Aid with JCL stream” on page 795](#)
- [“Diagnostics Aid reports” on page 796](#)
- [“Diagnostic messages and codes” on page 797](#)

---

## How to run Diagnostics Aid with JCL stream

To run IMS Database Reorganization Expert Diagnostics Aid (HPSCDIAG), supply an EXEC statement and a DD statement that defines the output data set.

### EXEC

This statement must be in the following form:

```
//stepname EXEC PGM=HPSCDIAG
```

### STEPLIB DD

This statement points to the load module library data set where HPSCDIAG load module resides:

```
//STEPLIB DD DISP=SHR,DSN=HPS.SHPSLMD0
```

where HPS.SHPSLMD0 is the name of the library that contains the IMS Database Reorganization Expert load modules.

### SHPSLMD DD

This statement defines the library containing the IMS Database Reorganization Expert load modules (typically HPS.SHPSLMD0) for which you have a problem.

If this DD statement is not provided, or if DD DUMMY is specified, the IMS Database Reorganization Expert Load Module APAR Status report is not generated.

It is always recommended that you specify this DD statement.

### SHPSMAC DD

This statement defines the library containing the provided IMS Database Reorganization Expert macros (typically HPS.SHPSMAC0) for which you have a problem.

If this DD statement is not provided, or if DD DUMMY is specified, the IMS Database Reorganization Expert Macro APAR Status report is not generated.

### SYSPRINT DD

This output data set contains the IMS Database Reorganization Expert Load Module/Macro APAR Status report. The data set contains 133-byte, fixed-length records. It can reside on a tape, direct-

access device, or printer; or it can be routed through the output stream. If BLKSIZE is coded in the DD statement, it must be a multiple of 133. However, it is recommended that you use the following:

```
//SYSPRINT DD SYSOUT=A
```

### Related reference

[Gathering diagnostic information](#)

Before you report a problem to IBM Software Support, gather the appropriate diagnostic information.

## Diagnostics Aid reports

---

Diagnostics Aid (HPSCDIAG) generates the following two reports for the IMS Database Reorganization Expert maintenance by IBM:

- IMS Database Reorganization Expert Load Module APAR Status report
- IMS Database Reorganization Expert Macro APAR Status report

### IMS Database Reorganization Expert Load Module APAR Status report

The IMS Database Reorganization Expert Load Module APAR Status report contains information about the modules and their applied APARs.

This report contains the following information:

#### MODULE LIBRARY

This includes the data set names specified in the SHPSLMD DD statement. If more than 30 data sets are concatenated, only the first 30 are listed.

#### MODULE NAME

This is the name of either the load module member or the alias that belongs to the IMS Database Reorganization Expert feature.

#### ALIAS-OF

This is the name of the original member of the alias. If the module name is not an alias, this field is left blank.

#### CSECT NAME

This is the name of the CSECT included in the module. The CSECT names are listed in the order in which they are included in the module.

#### APAR NUMBER

This is the latest APAR number applied to the module represented by the CSECT name. If no APAR is applied, NONE is shown.

#### APAR FIX-DATE

This is the date on which the modification for the module represented by the CSECT name was prepared. If no APAR is applied, N/A is shown.

#### Notes:

- If the CSECT name does not start with HPS, or if the program structure of the CSECT does not identify the APAR number and the APAR fixed date as specified by the IMS Database Reorganization Expert module standard, the fields APAR NUMBER and APAR FIX-DATE are filled with asterisks (\*).
- If the load module is a member of the PDSE library, the following statement is shown on the report line and the job completes with a return code of 4.

```
** IT CAN NOT BE ANALYZED DUE TO PDSE LIBRARY MEMBER **
```

- If the load macro for an IMS Database Reorganization Expert member fails, the following statement is shown on the report line and the job completes with a return code of 8.

```
** IT CAN NOT BE ANALYZED DUE TO LOAD FAILED MEMBER **
```

# IMS Database Reorganization Expert Macro APAR Status report

The IMS Database Reorganization Expert Macro APAR Status report contains information about macros and their applied APARs.

This report contains the following information:

## MACRO LIBRARY

This includes the data set names specified in the SHPSMAC DD statement. If more than 30 data sets are concatenated, only the first 30 are listed.

## MACRO NAME

This is the name of either the macro member or the alias that belongs to the IMS Database Reorganization Expert feature.

## ALIAS-OF

This is the name of the original member of the alias. If the macro name is not an alias, this field is left blank.

## APAR NUMBER

This is the latest APAR number applied to the macro. If no APAR is applied, NONE is shown.

## APAR FIX-DATE

This is the date on which the macro was modified. If no APAR is applied, N/A is shown.

If the macro source statement structure does not identify the APAR number and the APAR fixed date as specified in the IMS Database Reorganization Expert macro standard, the fields APAR NUMBER and APAR FIX-DATE are filled with asterisks (\*).

## Diagnostic messages and codes

---

The following topics describe the return codes, abend codes, and messages issued by IMS Database Reorganization Expert Diagnostics Aid.

### Return codes

HPSCDIAG contains the following return codes:

- 0**  
Successful completion of the program.
- 4**  
Warning messages were issued, but the requested operation was completed.
- 8**  
Error messages were issued, but the request operation was completed.

### Abend codes

All 36xx abend codes are accompanied by an HPSD36xx message. Refer to the appropriate message for problem determination.

### Messages

The HPSD messages are issued by the Diagnostic Aid.

<b>HPSD1001I</b>	<b>HPSCDIAG ENDED NORMALLY</b>	<b>System action</b>
		HPSCDIAG completes the job successfully with a return code of 0.
<b>Explanation</b>		<b>User response</b>
This message is generated when HPSCDIAG has been completed successfully.		None. This message is informational.

---

**HPSD1002W      HPSCDIAG ENDED WITH WARNINGS****Explanation**

This message is generated when trivial error conditions are encountered by HPSCDIAG.

**System action**

HPSCDIAG ends with a return code of 4.

**User response**

Refer to other messages generated by Diagnostic Aid to determine the nature and the cause of the detected errors. Correct the problem, and rerun the job.

---

**HPSD1003E      HPSCDIAG ENDED WITH ERRORS****Explanation**

This message is generated when severe error conditions are encountered by HPSCDIAG.

**System action**

HPSCDIAG ends with a return code of 8.

**User response**

Refer to other messages generated by HPSCDIAG to determine the nature and the cause of the detected errors. Correct the problem, and rerun the job.

---

**HPSD1005W      [SHPSLMD | SHPSMAC] DD STATEMENT NOT FOUND****Explanation**

HPSCDIAG could not find the SHPSLMD/SHPSMAC DD statement.

**System action**

HPSCDIAG sets an end-of-job return code of 4 and continues processing. HPSCDIAG does not generate a report for the load module or the macro.

**User response**

If you intended to specify the indicated DD statement, correct the error, and rerun the job.

---

**HPSD1006W      DUPLICATE *member name* IN LIBRARY DDNAME *ddname*****Explanation**

HPSCDIAG found a duplicated member in the concatenated libraries.

**System action**

HPSCDIAG uses the member that is first found in the concatenated libraries. HPSCDIAG sets an end-of-job return code of 4 and continues processing.

**User response**

Make sure which libraries have correct module/macro libraries. Correct the error, and rerun the job if necessary.

---

**HPSD1007W      DUMMY SPECIFIED FOR [SHPSLMD | SHPSMAC] DD STATEMENT****Explanation**

DUMMY was specified for the SHPSLMD/SHPSMAC DD statement.

**System action**

HPSCDIAG sets an end-of-job return code of 4 and continues processing. HPSCDIAG does not generate a report for the load module or the macro.

**User response**

If you did not intend to specify the dummy DD statement, correct the error, and rerun the job.

---

**HPSD1008W      NO IMS DB REORG EXPERT [MODULE | MACRO] MEMBERS FOUND IN DDNAME [SHPSLMD | SHPSMAC]****Explanation**

HPSCDIAG could not find any IMS Database Reorganization Expert modules or macros members from the DD ddname data set.

**System action**

HPSCDIAG sets an end-of-job return code of 4 and continues processing.

**User response**

Ensure that the libraries have correct IMS Database Reorganization Expert module or macro libraries. Correct the error and rerun the job.

---

**HPSD2001E      LOAD FAILED FOR DDNAME  
                  ddname MODULE member**

---

**Explanation**

HPSCDIAG could not load a *member name* from *ddname*.

**System action**

HPSCDIAG sets an end-of-job return code of 8 and continues processing.

**User response**

Make sure that the member indicated exists in the data set specified for the indicated *ddname*. Correct the error, and rerun the job.

---

**HPSD3600E      OPEN FAILED FOR DDNAME  
                  ddname**

---

**Explanation**

The named DCB could not be opened.

**System action**

HPSCDIAG ends with an abend code of U3600.

**User response**

Make sure that a *ddname* DD statement exists, and that it specifies the correct DD parameter. Correct any errors, and rerun the job.

---

**HPSD3601E      GET FAILED FOR DDNAME ddname**

---

**Explanation**

The GET failed for a directory from the DD *ddname* data set.

**System action**

HPSCDIAG ends with an abend code of U3601.

**User response**

Refer to the MVS system message and its programmer response. Correct the error, and rerun HPSCDIAG. If the error persists, report it to IBM.

---

**HPSD3602E      READ FAILED FOR DDNAME  
                  ddname MEMBER member**

---

**Explanation**

The READ failed for a *member* from the DD *ddname* data set.

**System action**

HPSCDIAG ends with an abend code of U3602.

**User response**

Refer to the MVS system message and its programmer response. Correct the error, and rerun HPSCDIAG. If the error persists, report it to IBM.

---

**HPSD3603E      BLDL FAILED FOR DDNAME  
                  ddname MEMBER member**

---

**Explanation**

The *member* was not found when the BLDL macro searched the PDS directory for the *ddname*.

**System action**

HPSCDIAG ends with an abend code of U3603.

**User response**

Make sure that the member indicated exists in the data set specified for the indicated *ddname*. Correct the error, and rerun the job. If the error persists, report it to IBM.

---

**HPSD3604E      LOAD FAILED FOR DDNAME  
                  ddname MODULE member**

---

**Explanation**

HPSCDIAG could not load the *member name* from the *ddname*.

**System action**

HPSCDIAG ends with an abend code of U3604.

**User response**

Refer to the MVS system message and its programmer response. Correct the error, and rerun HPSCDIAG. If the error persists, report it to IBM.

---

**HPSD3605E      DELETE FAILED FOR MODULE  
                  member**

---

**Explanation**

HPSCDIAG could not delete a *member name*.

### System action

HPSCDIAG ends with an abend code of U3605.

### User response

Report it to IBM.

---

### HPSD3606E PUT FAILED FOR SYSPRINT

### Explanation

HPSCDIAG could not put report data in SYSPRINT.

### System action

HPSCDIAG ends with an abend code of U3606.

### User response

Refer to the MVS system message and its programmer response. Correct the error, and rerun HPSCDIAG. If the error persists, report it to IBM.

---

### HPSD3607E OPEN FAILED FOR SYSPRINT

### Explanation

SYSPRINT DCB could not be opened.

### System action

HPSCDIAG ends with an abend code of U3607.

### User response

Make sure that a *ddname* SYSPRINT DD statement exists, and that it specifies the correct DD parameter. Correct any errors, and rerun the job.

---

### HPSD3608E FIND FAILED FOR DDNAME *ddname* MEMBER *member*

### Explanation

The FIND failed for a *member* from DDNAME *ddname* data set.

### System action

HPSCDIAG ends with an abend code of U3608.

### User response

Make sure that the member indicated exists in the data set specified for the indicated *ddname*. Correct the error, and rerun the job. If the error persists, report it to IBM.

---

### HPSD3609E DEVTYPE FAILED FOR DDNAME *ddname*

### Explanation

The DEVTYPE failed for DDNAME *ddname* data set.

### System action

HPSCDIAG ends with an abend code of U3609.

### User response

Report it to IBM.

---

### HPSD3610E RDJFCB FAILED FOR DDNAME *ddname*

### Explanation

The READJFCB failed for DDNAME *ddname* data set.

### System action

HPSCDIAG ends with an abend code of U3610.

### User response

Report it to IBM.

---

### HPSD3611E GETMAIN FAILED. INSUFFICIENT STORAGE TO RUN THE JOB

### Explanation

Workspace for HPSCDIAG could not be obtained.

### System action

HPSCDIAG ends with an abend code of U3611.

### User response

Increase the region size, and rerun the job.

---

### HPSD3612E TOO MANY IMS DB REORG EXPERT [MODULE | MACRO] MEMBERS DETECTED IN DDNAME [SHPSMOD | SHPSMAC]

### Explanation

Too many IMS Database Reorganization Expert members are in the SHPSMOD/SHPSMAC DD data set.

### System action

HPSCDIAG ends with an abend code of U3612.



## **User response**

Specify the correct data set for the indicated DD statement, and rerun the job.



## Notices

---

This information was developed for products and services offered in the U.S.A.

This material may be available from IBM in other languages. However, you may be required to own a copy of the product or product version in that language in order to access it.

IBM may not offer the products, services, or features discussed in this document in other countries. Consult your local IBM representative for information on the products and services currently available in your area. Any reference to an IBM product, program, or service is not intended to state or imply that only that IBM product, program, or service may be used. Any functionally equivalent product, program, or service that does not infringe any IBM intellectual property right may be used instead. However, it is the user's responsibility to evaluate and verify the operation of any non-IBM product, program, or service.

IBM may have patents or pending patent applications covering subject matter described in this document. The furnishing of this document does not give you any license to these patents. You can send license inquiries, in writing, to:

IBM Director of Licensing  
IBM Corporation  
North Castle Drive  
Armonk, NY 10504-1785  
U.S.A.

For license inquiries regarding double-byte (DBCS) information, contact the IBM Intellectual Property Department in your country or send inquiries, in writing, to:

Intellectual Property Licensing  
Legal and Intellectual Property Law  
IBM Japan Ltd.  
19-21, Nihonbashi-Hakozakicho, Chuo-ku  
Tokyo 103-8510, Japan

**The following paragraph does not apply to the United Kingdom or any other country where such provisions are inconsistent with local law:** INTERNATIONAL BUSINESS MACHINES CORPORATION PROVIDES THIS PUBLICATION "AS IS" WITHOUT WARRANTY OF ANY KIND, EITHER EXPRESS OR IMPLIED, INCLUDING, BUT NOT LIMITED TO, THE IMPLIED WARRANTIES OF NON-INFRINGEMENT, MERCHANTABILITY OR FITNESS FOR A PARTICULAR PURPOSE. Some states do not allow disclaimer of express or implied warranties in certain transactions, therefore, this statement may not apply to you.

This information could include technical inaccuracies or typographical errors. Changes are periodically made to the information herein; these changes will be incorporated in new editions of the publication. IBM may make improvements and/or changes in the product(s) and/or the program(s) described in this publication at any time without notice.

Any references in this information to non-IBM Web sites are provided for convenience only and do not in any manner serve as an endorsement of those Web sites. The materials at those Web sites are not part of the materials for this IBM product and use of those Web sites is at your own risk.

IBM may use or distribute any of the information you supply in any way it believes appropriate without incurring any obligation to you.

Licensees of this program who wish to have information about it for the purpose of enabling: (i) the exchange of information between independently created programs and other programs (including this one) and (ii) the mutual use of the information which has been exchanged, should contact:

IBM Director of Licensing  
IBM Corporation  
North Castle Drive

Armonk, NY 10504-1785  
U.S.A.

Such information may be available, subject to appropriate terms and conditions, including in some cases, payment of a fee.

The licensed program described in this information and all licensed material available for it are provided by IBM under terms of the IBM Customer Agreement, IBM International Program License Agreement, or any equivalent agreement between us.

Any performance data contained herein was determined in a controlled environment. Therefore, the results obtained in other operating environments may vary significantly. Some measurements may have been made on development-level systems and there is no guarantee that these measurements will be the same on generally available systems. Furthermore, some measurements may have been estimated through extrapolation. Actual results may vary. Users of this document should verify the applicable data for their specific environment.

#### COPYRIGHT LICENSE:

This information contains sample application programs in source language, which illustrate programming techniques on various operating platforms. You may copy, modify, and distribute these sample programs in any form without payment to IBM, for the purposes of developing, using, marketing or distributing application programs conforming to the application programming interface for the operating platform for which the sample programs are written. These examples have not been thoroughly tested under all conditions. IBM, therefore, cannot guarantee or imply reliability, serviceability, or function of these programs. The sample programs are provided "AS IS", without warranty of any kind. IBM shall not be liable for any damages arising out of your use of the sample programs.

If you are viewing this information softcopy, the photographs and color illustrations may not appear.

## Programming interface information

This guide is intended to help the customer to use the IMS Database Reorganization Expert for z/OS.

This guide also documents intended general-use programming interface and associated guidance information, product-sensitive programming interface and associated guidance information, and diagnosis, modification, or tuning information for IMS Database Reorganization Expert. General-use programming interface enables the customer to write programs that obtain the services of IMS Database Reorganization Expert. This information is identified where it occurs, either by an introductory statement to a topic or by the following marking:

 GUPI

General-use programming interface and associated guidance information...

 GUPI

Product-sensitive programming interfaces are provided to allow the customer installation to perform tasks such as tailoring, monitoring, modification, or diagnosis of this IBM product. Use of such interfaces creates dependencies on the detailed design or implementation of the IBM product. Product-Sensitive interfaces should be used only for these specialized purposes. Because of their dependencies on detailed design and implementation, it is to be expected that programs written to such interfaces might need to be changed in order to run with new product releases or versions, or as a result of service. Product-Sensitive Programming Interface and Associated Guidance Information is identified where it occurs, either as an introductory statement to a chapter or section or by the following marking:

 PSPI

Product-sensitive programming interface and associated guidance information...

PSPI

This guide also documents product-sensitive programming interface and associated guidance information; and diagnosis, modification, or tuning information. Diagnosis, modification, or tuning information is provided to help the customer determine problems or tune the performance of the IMS Database Reorganization Expert for z/OS.



**Warning:** Do not use this Diagnosis, Modification, and Tuning Information as a programming interface.

Diagnosis, Modification, and Tuning Information is identified where it occurs, either by an introductory statement to a chapter or section or by the following marking:

DMTI

Diagnosis, modification, or tuning information...

DMTI

## Trademarks

IBM, the IBM logo, and [ibm.com](http://www.ibm.com)<sup>®</sup> are trademarks or registered trademarks of International Business Machines Corp., registered in many jurisdictions worldwide. Other product and service names might be trademarks of IBM or other companies. A current list of IBM trademarks is available on the web at "Copyright and trademark information" at <http://www.ibm.com/legal/copytrade.shtml>.

Other company, product, and service names may be trademarks or service marks of others.

## Terms and conditions for product documentation

Permissions for the use of these publications are granted subject to the following terms and conditions:

**Applicability:** These terms and conditions are in addition to any terms of use for the IBM website.

**Personal use:** You may reproduce these publications for your personal, noncommercial use provided that all proprietary notices are preserved. You may not distribute, display or make derivative work of these publications, or any portion thereof, without the express consent of IBM.

**Commercial use:** You may reproduce, distribute and display these publications solely within your enterprise provided that all proprietary notices are preserved. You may not make derivative works of these publications, or reproduce, distribute or display these publications or any portion thereof outside your enterprise, without the express consent of IBM.

**Rights:** Except as expressly granted in this permission, no other permissions, licenses or rights are granted, either express or implied, to the publications or any information, data, software or other intellectual property contained therein.

IBM reserves the right to withdraw the permissions granted herein whenever, in its discretion, the use of the publications is detrimental to its interest or, as determined by IBM, the above instructions are not being properly followed.

You may not download, export or re-export this information except in full compliance with all applicable laws and regulations, including all United States export laws and regulations.

IBM MAKES NO GUARANTEE ABOUT THE CONTENT OF THESE PUBLICATIONS. THE PUBLICATIONS ARE PROVIDED "AS-IS" AND WITHOUT WARRANTY OF ANY KIND, EITHER EXPRESSED OR IMPLIED, INCLUDING BUT NOT LIMITED TO IMPLIED WARRANTIES OF MERCHANTABILITY, NON-INFRINGEMENT, AND FITNESS FOR A PARTICULAR PURPOSE.

## Privacy policy considerations

IBM Software products, including software as a service solutions, ("Software Offerings") may use cookies or other technologies to collect product usage information, to help improve the end user experience, to tailor interactions with the end user or for other purposes. In many cases no personally identifiable information is collected by the Software Offerings. Some of our Software Offerings can help enable you to collect personally identifiable information. If this Software Offering uses cookies to collect personally identifiable information, specific information about this offering's use of cookies is set forth below.

This Software Offering does not use cookies or other technologies to collect personally identifiable information.

If the configurations deployed for this Software Offering provide you as customer the ability to collect personally identifiable information from end users via cookies and other technologies, you should seek your own legal advice about any laws applicable to such data collection, including any requirements for notice and consent.

For more information about the use of various technologies, including cookies, for these purposes, see IBM's Privacy Policy at <http://www.ibm.com/privacy> and the section titled "Cookies, Web Beacons, and Other Technologies" in IBM's Online Privacy Statement at <http://www.ibm.com/privacy/details>. Also, see the "IBM Software Products and Software-as-a-Service Privacy Statement" at <http://www.ibm.com/software/info/product-privacy>.

# Index

## Special Characters

(-10,+10) [373](#)  
\*A1 [377](#)  
\*A2 [377](#)  
\*A3 [377](#)  
\*A4 [377](#)  
\*CP [378](#)  
\*CS [378](#)  
\*F1 [378](#)  
\*F2 [378](#)  
\*F3 [378](#)  
\*F6 [378](#)  
\*HD [378](#)  
\*NO [378](#)  
\*SH [378](#)  
\*UH [378](#), [387](#)  
/DBD [50](#), [72](#), [140](#), [186](#)  
/DBDUMP [211](#)  
/DBR [50](#), [72](#), [140](#), [185](#), [186](#)  
/DBRECOVERY [211](#), [212](#)  
/STA [158](#)  
/START DB [158](#), [215](#)

## A

A2 Format [381](#)  
A3 Format [381](#)  
A4 Format [381](#)  
abend codes [664](#)  
ABEND=  
    NO [593](#)  
    YES [590](#)  
accessibility  
    overview [36](#)  
ADDBGPR= [127](#), [593](#)  
ADXCFGRP= [127](#), [593](#)  
ALTER=  
    NO [104](#)  
AMP= [514](#)  
APF-authorized  
    HPIO=NO [492](#)  
API for IPR Unload utility [461](#)  
APISET= [362](#), [392](#), [396](#), [397](#), [399](#), [403](#)  
APPL=(pgm,psb,rgn) [472](#)  
application programming interface [18](#)  
AUTHFAIL=  
    ABORT [128](#), [131](#), [140](#), [735](#)  
    WTOR [72](#), [73](#), [131](#), [140](#), [178](#), [185](#), [186](#), [211](#), [735](#)  
automatic RECON Loss Notification [48](#)  
Autonomics Director [16](#)

## B

BBBR [526](#), [560](#)  
BBEERROR  
    data set [280](#)

BBEJRNL  
    data set [279](#)  
BLDLPCK= [97](#), [355](#), [356](#), [362](#), [363](#), [392](#), [482](#), [662](#)  
blocks  
    REORG [118](#), [167](#)  
    UNLOAD [167](#)  
BMSETDSG= [509](#)  
BSAM [514](#)  
BSNJM01  
    data set [280](#)  
Buffering and I/O Statistics report [447](#)  
BUFFERNO= [510](#)  
BUFFERS= [392](#)  
BUFNO= [510](#)  
BUFS= [392](#)  
BUFSTAT=  
    YES [160](#)  
BYINDEX=  
    NO [591](#)  
    secondary index [395](#)  
BYTELIMIT= [510](#)

## C

CAB  
    statistics [395](#)  
CABBASE= [396](#)  
CABDD [392](#)  
CEE3SRC [582](#)  
CEEPIPI  
    call\_sub [579](#)  
Chained Anticipatory Buffering [409](#)  
CHANGE.DB  
    NOAUTH [72](#), [131](#), [178](#), [728](#), [735](#)  
    OLRDBDS(A) [728](#)  
    READON [72](#), [131](#), [178](#), [728](#), [735](#)  
CHANGE.IC [47](#)  
checkpoint and restart [23](#), [58](#), [488](#)  
CHECKREC= [370](#), [512](#)  
CHKEMPTYUL= [511](#)  
CHKPT statement [586](#)  
CHKTRAIL= [511](#)  
CHKUPDT= [512](#)  
CLASS [175](#)  
Cleanup utility [296](#)  
CMDMCS= parameter [50](#)  
CO= [397](#)  
COBOL II runtime environment [402](#)  
COMPAREDLI=  
    YES [99](#), [363](#)  
COMPAUTH= [398](#), [512](#)  
COMPRESS=  
    NO [554](#), [559](#)  
    YES [554](#)  
compression routine  
    FABJCMP3 [178](#)  
COMPRTN parameter [150](#), [372](#), [513](#)

COMPRTN=  
     (,,,PAD) [420, 550](#)  
     (,,,max) [420, 447, 550, 565](#)  
 Concurrent Prefix Update [58](#)  
 Conditional Reorganization mode [55](#)  
 Conditional Reorganization Support Service [17, 61](#)  
 CONDREORG= [128](#)  
 control statements  
     Conditional Reorganization Support Service [162](#)  
     Image Copy task [177](#)  
     Index Builder task [175](#)  
     IPR DB Scan utility  
         DB Scan function [591, 592](#)  
         HSSR Engine [389, 591](#)  
     IPR Reload utility [502](#)  
     IPR Unload utility  
         HSSR Engine [367, 389](#)  
         unload function [367](#)  
     Post-reorganization utility [319](#)  
     Pre-reorganization utility [305](#)  
     Prefix Resolution task [176](#)  
     Reload task [170](#)  
     Smart Reorg Driver [118](#)  
     syntax [118](#)  
     Unload task  
         HSSR Engine [167](#)  
         Unload function [167](#)  
 cookie policy [803](#)  
 creating empty database [538](#)  
 CRIC= [130](#)  
 CRSS [61](#)  
 CRUNLOAD= [130](#)

## D

Data Conversion exit routine [23, 58, 398, 458, 514](#)  
 data element [65](#)  
 data flow  
     IPR DB Scan utility [585](#)  
     IPR Reload utility [486](#)  
     IPR Unload utility [353](#)  
 data set name swapping [69](#)  
 Data Set Statistics report [444](#)  
 database DD statements [495](#)  
 database organization types  
     HDAM [69, 178, 351, 352, 485](#)  
     HIDAM [69, 178, 351, 352, 485](#)  
     HISAM [69, 178, 351, 352, 485](#)  
     PHDAM [58, 69, 351, 352, 485, 486](#)  
     PHIDAM [58, 69, 351, 352, 485, 486](#)  
     SHISAM [69, 178, 351, 485](#)  
 DATXEXIT=  
     NO [398](#)  
     YES [380, 458](#)  
 DB Sensor [65](#)  
 Db2 DL/I batch interface [471](#)  
 DBB [462](#)  
 DBD  
     decode [133, 134, 371, 516](#)  
 DBD name [248, 381, 416, 546, 580, 604, 606](#)  
 DBD Snap report [578](#)  
 DBD Summary report [416](#)  
 DBD= [413, 543](#)  
 DBD=dbdname [89, 359, 492](#)

DBDSNAP=  
     YES [98, 281, 578](#)  
 DBIOBUF= [514](#)  
 DBRC  
     command  
         CHANGE.DB [72, 131, 178, 213, 489, 728, 735](#)  
         NOTIFY.REORG [72, 138, 149, 213](#)  
         NOTIFY.UIC [72, 138, 213](#)  
     Command Authorization [47](#)  
     notification  
         manual [213](#)  
     NOTIFY command  
         RUNTIME parameter [110](#)  
     registered [147](#)  
     SCI Registration exit  
         routine [48](#)  
 DBRC environment [47](#)  
 DBRC= [89, 359, 413, 492, 543, 587](#)  
 DBRCAUTHCMD=  
     NO [131](#)  
     YES [47, 72, 73, 131, 211, 720](#)  
 DBRCGRP= [48, 90, 359, 492, 587](#)  
 DBRDIST= [370, 515](#)  
 DBRECDIST control statement [170, 780](#)  
 DBRECDIST=  
     0 [409, 442, 564](#)  
 DBRECKEYS= [371](#)  
 DBRLBUF= [516](#)  
 DBS [586](#)  
 DBS\_HPIO= [164](#)  
 DBS= [593](#)  
 DBSHARE=  
     NO [106, 131, 140, 211, 720, 721, 735](#)  
     YES [106, 131, 140, 185, 186, 211, 720, 721, 735](#)  
 DBSTATS=  
     NO [399](#)  
     YES [240, 398, 409, 440, 441, 478](#)  
 DCB= [514](#)  
 DD names  
     BBEJRNL [98](#)  
     BBERPRT [98](#)  
     BSNJM01 [98](#)  
     common to all processing options [95](#)  
     database [474, 495](#)  
     dataout1/stack1 [103](#)  
     dataout2/stack2 [102](#)  
     DDEFPPDS [495](#)  
     DDEFPPDS2 [97](#)  
     ddname [362, 589](#)  
     DFSACBPD [97](#)  
     DFSHALDB [474](#)  
     DFSPRINT [103](#)  
     DFSRESLB [96, 362, 473, 589](#)  
     DFSUINPT [99, 490, 494, 520](#)  
     DFSURCDS [102, 187, 494, 589](#)  
     DFSURGU1 [364](#)  
     DFSURGU2 [364](#)  
     DFSURWF1 [99, 187, 495, 590, 604, 605](#)  
     DFSVSAMP [97, 362, 474, 494](#)  
     EVALUPRT [103](#)  
     FABYMSG [102](#)  
     FABYPRNT [102](#)  
     for HASH pointer checking [103](#)  
     for Image Copy processing [102](#)



DD names (*continued*)

for Index Builder task [101](#)  
for logical relationship processing [102](#)  
for Reload task [99](#)  
for Unload task [99](#)  
HISTORY [104](#)  
HPSDSPAP [98](#)  
HPSGAMSA [97](#)  
HPSGCTL [97](#), [589](#)  
HPSGSWAP [98](#)  
HPSIN [97](#), [184](#), [363](#), [474](#), [494](#), [589](#)  
HPSLIST [99](#), [160](#), [363](#), [474](#), [590](#)  
HPSLOUT [364](#)  
HPSOUT [98](#), [363](#), [474](#), [499](#), [541](#), [590](#)  
HPSOUT2 [98](#)  
HPSRAMSO [499](#)  
HPSRAPC [363](#)  
HPSRPnnn [496](#)  
HPSRSIDX [100](#), [497](#)  
HPSSNAP [98](#), [363](#), [474](#), [499](#), [541](#), [590](#)  
HPSSTAT [99](#), [159](#)  
HPSTRACE [99](#), [363](#), [474](#), [590](#)  
ICEIN [102](#), [117](#)  
ICEPRINT [102](#)  
ICERPRT [103](#)  
IIUPRINT [101](#), [186](#)  
IIUSNAP [102](#)  
IIUSOUT [102](#), [186](#)  
IMS [96](#), [362](#), [473](#), [494](#), [589](#)  
IMSACB [474](#)  
IMSDALIB [96](#), [362](#)  
JOB LIB [456](#), [520](#)  
LINKLIB [520](#)  
new\_dbdlib [96](#)  
original\_dbds [96](#)  
OVERFLOW [100](#), [497](#)  
PRIMAPRT [103](#)  
PROCLIB [97](#), [474](#), [589](#)  
RECONx [97](#), [363](#), [474](#), [495](#), [589](#)  
SEQERROR [100](#), [499](#)  
shadow\_dbds [98](#)  
sindex [101](#)  
SNAPPIT [103](#)  
SORTLIB [102](#)  
SORTWKnn [498](#)  
STATIPRT [103](#)  
STEPLIB [95](#), [361](#), [392](#), [456](#), [473](#), [493](#), [520](#), [588](#)  
SUMMARY [104](#)  
SYSABEND [499](#)  
SYSUDUMP [99](#), [474](#), [499](#), [590](#)  
SYSUT1 [363](#)  
SYSUT2 [364](#), [375](#)  
SYSUT3 [99](#), [364](#), [375](#)  
SYSUT4 [99](#), [364](#), [375](#)  
VALIDPRT [103](#)

DD statements

Diagnostics Aid [795](#)  
IMS HD Reorganization Unload [365](#)  
IPR DB Scan utility [587](#)  
IPR Reload utility [491](#)  
IPR Unload utility [359](#), [472](#)  
Post-reorganization utility [313](#)  
Pre-reorganization utility [301](#)  
Smart Reorg utility [90](#)

DDNMAP= [133](#)  
DEC= [372](#)  
DECODEDBD  
Installation Default Option Table [617](#)  
IPR Reload utility  
control statement [516](#)  
Decoded DBD report [546](#)  
IPR Unload utility  
control statement [371](#)  
Decoded DBD report [416](#)  
Smart Reorg utility  
control statement [133](#)  
Decoded DBD report [255](#)  
Decoded New DBD report [256](#)  
DECODEDBD=  
NO [372](#), [516](#)  
YES [361](#), [409](#), [493](#), [784](#)  
DECODESX  
Installation Default Option Table [617](#)  
Smart Reorg utility  
control statement [134](#)  
Decoded DBD report [255](#)  
Decoded New DBD report [256](#)  
DECODESX=  
YES [698](#)  
DECOMPRESS=  
NO [150](#), [372](#), [428](#), [434](#), [457](#), [513](#), [514](#), [579](#)  
YES [149](#), [352](#), [356](#), [363](#), [372](#), [378](#), [406](#), [428](#), [458](#)  
Default Option Tables report [241](#), [414](#)  
DELOLDDS  
Smart Reorg utility  
control statement [135](#)  
DELOLDDS=  
YES [255](#), [269](#)  
device type [131](#)  
DFSCCMD0 [50](#)  
DFSDBUX1 [23](#)  
DFSDF= [90](#), [301](#), [314](#)  
DFSHALDB [489](#)  
DFSMDA member [261](#)  
DFSPRECO [139](#), [213](#)  
DFSUDMPO [213](#)  
DFSUIINPT  
data set [494](#)  
DFSUPNTO [485](#)  
DFSURCDS [109](#), [494](#), [585](#), [593](#), [604](#)  
DFSURCDS data set [585](#), [593](#), [594](#), [597](#), [602](#)  
DFSURGL0 [17](#)  
DFSURGS0 [17](#)  
DFSURGU0 [485](#)  
DFSURGU1 [364](#)  
DFSURGU2 [364](#)  
DFSURPRO [354](#)  
DFSURWF1 [109](#), [153](#), [495](#), [585](#), [604](#), [605](#)  
DFSURWF1 data set [605](#)  
DFSVSAMP data set [494](#)  
DIAGDATAFROM= [164](#)  
DIAGG [481](#), [482](#)  
DIAGG=  
NO [399](#)  
TRACE [363](#), [590](#)  
YES [99](#), [357](#), [363](#), [399](#), [406](#), [590](#)  
Diagnosis mode [55](#)  
diagnostic messages and codes [797](#)

diagnostics aid [795](#)  
DIAGONLY [181](#)  
dir\_buf\_num [394](#)  
DISPOLDDS=  
    DELETE [135](#)  
    Installation Default Option Table [617](#)  
    NEWSHADOW [135](#)  
    TEMPNAME [135](#)  
Distribution of Database Record Sizes report [442](#)  
DLI [462](#)  
DLIBATCH application program [466](#)  
documentation  
    accessing [34](#)  
    sending feedback [34](#)  
documentation changes [3](#)  
DSPURX00 [73](#), [149](#), [257](#), [262](#), [266](#), [727](#), [728](#), [731](#), [737](#)  
DUMMY [663](#)  
DYNALOC [72](#)  
DYNALOC= [104](#), [136](#), [185](#), [186](#)  
dynamic allocation  
    temporary data set [131](#)

## E

E-MCS  
    console [50](#), [72](#)  
empty database [538](#)  
entire HALDB [122](#)  
ESDS [393](#), [394](#)  
ESDS CI [394](#)  
esoteric name [131](#)  
EXEC statements  
    Diagnostics Aid [795](#)  
    IMS HD Reorganization Unload [365](#)  
    IPR DB Scan utility [587](#)  
    IPR Reload utility [491](#)  
    IPR Unload utility [359](#), [472](#)  
    Post-reorganization utility [313](#)  
    Pre-reorganization utility [301](#)  
    Smart Reorg utility [89](#)  
exit routine interface  
    register contents [580](#)  
    return codes [581](#)  
Extended Multiple Console Support [48](#)  
EXTENT= [516](#)  
external logical relationships [287](#)

## F

F6 format [381](#)  
FABHFSU [351](#), [354](#), [455](#), [456](#)  
FABHRTEX [402](#)  
FABHURG1 [354](#)  
FABJCMP3  
    compression routine [178](#)  
FABJGLB0 [177](#)  
FALLBACK= [372](#)  
FRSPC= [446](#), [517](#), [570](#)  
FUNC=  
    RL [492](#)  
    SN [587](#)  
    UL [359](#), [472](#)

## G

GDGBASE= [517](#)  
GDGLIMIT= [517](#)  
global service group (GSG) [360](#)  
GN calls [462](#)  
GNP calls [462](#)  
group name [131](#)  
GSGNAME= [90](#), [360](#), [413](#), [493](#), [543](#), [588](#)  
GU call [462](#)

## H

HALDB  
    ILDS [75](#), [104](#), [122](#), [213](#)  
    indirect list data set [75](#), [104](#), [107](#), [136](#)  
    master database [140](#)  
    Online Reorganization (OLR) [355](#)  
    partition [69](#), [72](#), [357](#), [485](#)  
HALDB Index/ILDS Rebuild utility (DFSPREC0) [110](#)  
HALDB Partition Data Set Initialization utility [485](#)  
HALDB Partition Definition report [451](#)  
HALDB Partitions Processed report [421](#)  
HASH pointer checking  
    DD names [103](#)  
HD Pointer Checker utility [482](#)  
HD Reorganization Reload utility [17](#)  
HD Reorganization Unload utility [17](#)  
HD-format unload data set [356](#)  
HDAM [110](#)  
HDAM RAP Chain I/O Summary report [439](#)  
HDAM RAPCHECK Incorrect RAP Chain report [452](#)  
HDAM Root Addressable Area Statistics report [435](#)  
HDPC=  
    O [110](#), [114](#)  
    Y [103](#), [110](#), [114](#)  
HIDAM [110](#)  
High Speed Sequential Retrieval [17](#)  
HISAM [110](#)  
HISAM Statistics report [443](#)  
home block [373](#), [436](#), [438](#), [439](#), [527](#), [560](#), [562](#), [563](#), [632](#)  
HOMECHK control statement [436](#), [439](#), [780](#)  
HOMECHK=  
    (O) [373](#), [435](#), [436](#)  
    O [373](#)  
HPIO [504](#), [518](#)  
HPIO= [137](#)  
HPPRBH= [177](#)  
HPSCDIAG [795](#)  
HPSCOPT examples [625](#)  
HPSCOPT macro [617](#), [618](#)  
HPSCOPT= [618](#)  
HPSCOPTG [617](#), [618](#)  
HPSCOPTI [617](#), [618](#)  
HPSG0336A [140](#)  
HPSGAMSA [97](#)  
HPSGMAIN [50](#)  
HPSGSWAP [98](#)  
HPSIN  
    control statement blocks  
        (CONDREORG) [162](#)  
        (INDEXBLD) [117](#), [175](#)  
        (PREFIXRES) [117](#)  
        (RELOAD) [117](#), [170](#)

HPSIN (*continued*)  
 control statement blocks (*continued*)  
 (REORG) [117](#)  
 (UNLOAD) [117](#), [167](#)  
 PREFIXRES [176](#)  
 UNLOAD [160](#)  
 data set [501](#), [597](#)  
 HPSIN Control Statements report [414](#)  
 HPSLIST  
 data set [271](#), [409](#), [601](#)  
 HPSLOUT [364](#)  
 HPSOUT  
 data set  
 IPR Reload utility [499](#), [541](#)  
 HPSOUT2 data set [254](#)  
 HPSRAPC [363](#)  
 HPSRSIDX [109](#), [497](#), [663](#)  
 HPSSNAP  
 data set [281](#), [409](#), [578](#), [601](#)  
 IPR Reload utility [499](#), [578](#)  
 IPR Unload utility [409](#)  
 HPSSTAT data set [271](#)  
 HPSTRACE  
 data set [281](#), [399](#), [409](#), [601](#)  
 HPSUCOB2 [402](#)  
 HPSURTEX [402](#)  
 HSSR  
 application program [461](#), [466](#)  
 call [461](#), [464](#)  
 Engine [17](#), [351](#), [389](#), [461](#), [468](#), [585](#), [601](#), [662](#), [664](#)  
 PCB  
 mask [468](#)  
 HSSR-eligible PCB [462](#)  
 HSSRCABP [392](#), [395](#)  
 HSSROPT [392](#)  
 HSSRSNAP  
 data set [601](#)  
 HSSRSTAT [409](#), [601](#)  
 HSSRTRAC  
 data set [601](#)

**I**

I/O area [469](#)  
 IBM recommends [89](#), [97](#), [104](#), [137](#), [147](#), [363](#), [495](#), [589](#)  
 IC NEEDED flag [110](#)  
 IC=  
 YES [47](#), [90](#), [102](#), [109](#), [110](#), [177](#), [266](#)  
 IC=YES [179](#)  
 ICNEEDED  
 flag [72](#)  
 ICNEEDED= [138](#)  
 ICREQ [110](#)  
 ICTIME parameter  
 Image Copy Dump Process report [268](#)  
 ICTYPE=  
 A [90](#)  
 B [109](#), [110](#)  
 IDCAMS [72](#), [179](#), [185](#), [212](#), [263](#), [264](#), [489](#), [726](#), [727](#), [731](#)  
 IIUBSRT [49](#)  
 IIUPRINT data set [282](#)  
 IIUSOUT data set [282](#)  
 ILDS [104](#), [110](#), [139](#)  
 ILDSBLD=

ILDSBLD= (*continued*)  
 NO [98](#), [137](#), [148](#), [213](#)  
 ILE [139](#), [148](#)  
 ILEDATAC= [519](#)  
 ILESTORC= [519](#)  
 image copy  
 control statements  
 AIC [114](#), [178](#)  
 COMP=Y parameter [178](#)  
 COMPRTN parameter [178](#)  
 DBBUF parameter [178](#)  
 GLOBAL [110](#), [114](#)  
 HDPC=Y parameter [178](#)  
 IC [114](#), [178](#)  
 ICOUT parameter [178](#)  
 STACK parameter [178](#)  
 UNIT=SYSALLDA parameter [178](#)  
 WAIT [178](#)  
 stacking [111](#)  
 timestamp [110](#)  
 Image Copy  
 Type-A  
 secondary index [102](#), [103](#)  
 Type-B [74](#), [75](#), [110](#), [113](#), [139](#), [153](#), [178](#)  
 image copy data set  
 ALTER authority [49](#)  
 CONTROL authority [49](#)  
 GDG [49](#)  
 secondary index [75](#)  
 security [49](#)  
 tape [49](#)  
 improving the performance  
 IPR Reload utility [614](#)  
 IPR Unload utility [612](#)  
 Smart Reorg utility [609](#)  
 IMS [15](#), [48](#)  
 IMS Command Authorization Exit routine [50](#)  
 IMS Command Processing report [270](#)  
 IMS data set [494](#)  
 IMS Database Image Copy utility [489](#)  
 IMS Database Prefix Resolution utility [495](#), [585](#)  
 IMS Database Preorganization utility (DFSURPRO) [102](#),  
[109](#), [192](#), [214](#), [355](#), [356](#), [392](#), [482](#), [490](#), [494](#), [585](#), [589](#),  
[593](#), [768](#)  
 IMS Database Repair Facility [481](#), [482](#)  
 IMS Database Scan utility [17](#), [496](#), [585](#)  
 IMS HALDB Index/ILDS Rebuild utility [139](#), [213](#)  
 IMS HALDB Partition Data Set Initialization utility [485](#), [525](#)  
 IMS HALDB Partition Definition utility [249](#), [489](#)  
 IMS HALDB Partition Initialization utility [490](#)  
 IMS HD Reorganization Reload utility [17](#), [139](#), [352](#), [481](#)  
 IMS HD Reorganization Unload utility [17](#), [482](#), [485](#), [489](#)  
 IMS HP Image Copy  
 GLOBAL site default table (FABJGLB0) [177](#)  
 IMS HP Load [15-17](#), [39](#), [493](#), [560](#), [638](#)  
 IMS HP Pointer Checker [15](#), [16](#), [39](#), [69](#), [74](#), [103](#), [282](#), [482](#)  
 IMS HP Prefix Resolution [15](#), [16](#), [39](#), [58](#), [69](#), [74](#), [109](#), [153](#),  
[176](#), [495](#)  
 IMS HP Unload [15-17](#), [39](#), [240](#), [361](#), [409](#), [461](#), [468](#), [478](#),  
[479](#), [485](#), [585](#), [601](#)  
 IMS Index Builder [15-17](#), [39](#), [104](#), [143](#), [147](#), [149](#), [175](#), [240](#),  
[495](#), [737](#)  
 IMS Library Integrity Utilities [15](#), [16](#), [39](#), [133](#), [134](#), [361](#), [371](#),  
[493](#), [516](#), [696](#)

IMS management of ACBs [115](#), [201](#)  
IMS Online Reorganization Facility [16](#)  
IMS Parallel Reorganization [17](#)  
IMS Prefix Resolution and Prefix Update utilities [214](#)  
IMS Tools Base [17](#)  
IMS Tools KB [17](#), [39](#), [144](#), [351](#), [373](#), [374](#), [485](#), [520](#), [521](#)  
IMS Tools Knowledge Base [15](#)  
IMS Tools Online System Interface [15](#), [17](#)  
IMS Utility Control Facility (UCF) [23](#)  
IMS-managed ACBs [115](#), [201](#)  
IMS/ESA Year 2000 Conversion Exit [514](#)  
IMSCMD=  
    NO [72](#), [131](#), [211](#)  
    YES [50](#), [72](#), [73](#), [131](#), [140](#), [185](#), [186](#), [211](#), [720](#)  
IMSCMDOPT= [142](#)  
IMSDALIB [96](#), [362](#), [491](#), [493](#)  
IMSID=ssna [89](#)  
IMSPLEX= [90](#), [359](#), [492](#), [587](#)  
Index Builder  
    SORT address space [75](#)  
INDEXBLD=  
    NO [101](#), [143](#)  
    YES [49](#), [58](#), [72](#), [75](#), [90](#), [101](#), [104](#), [143](#), [149](#), [151](#), [186](#)  
    YES,CURRENT [104](#), [106](#), [143](#)  
    YES,NEW [104](#), [106](#), [143](#)  
indirect list data set (ILDS) [139](#)  
indirect list entry (ILE) [139](#)  
INPUT= [520](#)  
INQONLY [140](#)  
Installation Default Option Table [617](#)  
introduction [3](#)  
IOAREA [403](#)  
IPR DB Scan utility [17](#), [585](#)  
IPR Reload utility [17](#), [481](#), [485](#)  
IPR Unload utility [17](#), [351](#), [455](#), [456](#), [481](#), [485](#), [489](#)  
IPRPIPE [70](#), [72](#)  
IRLM= [90](#), [359](#), [413](#), [493](#), [543](#), [587](#)  
IRLMNM= [90](#), [360](#), [413](#), [493](#), [543](#), [587](#)  
ITKBDATA= [143](#)  
ITKBLOAD= [144](#), [351](#), [373](#), [485](#), [520](#)  
ITKBSRVR= [144](#), [351](#), [374](#), [485](#), [521](#)

## J

JOURNAL= [164](#)

## K

KEYCHECK=  
    GG [357](#), [406](#), [421](#), [425](#), [482](#), [591](#)  
    GX [421](#), [425](#), [469](#)  
    NO [400](#)  
KEYLABELCHK= [145](#)

## L

Largest Database Records report [443](#)  
LASTAUTHFLAG= [146](#)  
legal notices  
    cookie policy [803](#)  
    notices [803](#)  
    programming interface information [803](#)  
    trademarks [803](#)

LIST.DB [47](#)  
LIST.RECON  
    STATUS [47](#)  
LIST.SUBSYS [47](#)  
LMU [662](#), [663](#)  
logical relationship  
    external [109](#), [147](#), [214](#)  
    HISAM [109](#)  
    internal [109](#), [110](#), [139](#), [147](#), [153](#), [214](#)  
LOGREL= [594](#)  
LOUT= [400](#)  
LPART= [522](#)  
LPCK [354](#), [392](#)

## M

MAXTASKS [175](#)  
MCSOPER macro [50](#)  
messages and codes [661](#)  
MIGRATE= [375](#)  
MVS catalog [147](#)

## N

name swapping  
    manual [212](#)  
NAMESWAP=  
    NO [138](#), [147](#), [214](#), [264](#), [726](#), [730](#)  
    YES [104](#), [147](#), [185-187](#), [263](#), [720](#), [726](#), [730](#), [737](#)  
NAMESWAPFAIL= [148](#)  
NBRDBUF [392](#)  
NBRSRAN [392](#)  
NCP= [514](#)  
NEWDBD [108](#), [149](#)  
NOFIX [392](#)  
NOICREQ [110](#)  
non-HALDB [178](#), [489](#)  
non-partitioned database [104](#), [447](#), [482](#)  
NONRECOV [110](#), [138](#), [214](#)  
notices [803](#)  
NOTIFY.IC [47](#), [110](#), [268](#)  
NOTIFY.REORG [47](#), [72](#), [110](#), [138](#), [147](#), [149](#), [213](#)  
NOTIFY.UIC [47](#), [72](#), [110](#), [138](#), [213](#), [268](#)

## O

OADSPR= [172](#), [523](#)  
online reorganization capable (OLRCAP) [69](#)  
OPTIONS(FETCHABLE) [582](#)  
OPTIONS(MAIN) [582](#)  
original  
    data set [69](#), [104](#), [107](#)  
    database [96](#), [104](#)  
OSAM  
    block [394](#)  
OUTPUT= [375](#)  
OUTREC= [594](#)  
OVERFLOW  
    CAB [392](#)  
    SHR [392](#)  
OVERFLOW data set [100](#), [497](#), [523](#)  
ovflw\_buf [394](#)

## P

PAD= [523](#)  
pagefix [394](#)  
parallel reorganization  
    non-HALDB [178](#)  
Parallel Reorganization Service [17](#)  
PARTINFO  
    control statement [170](#)  
PARTINFO=  
    NO [451](#), [576](#)  
    YES [401](#), [409](#), [524](#)  
PARTINIT=  
    YES [489](#), [490](#)  
    YES,LPART [525](#)  
    YES,PINITON [524](#)  
    YES,UNLOAD [524](#)  
PARTINIT=NO [490](#)  
PARTITION  
    high key [249](#), [250](#)  
    ID [249](#)  
    IPR Unload utility  
        control statement [384](#)  
    name [249](#)  
    selection exit [248–250](#)  
    selection string [249](#)  
    Smart Reorg  
        control statement [187](#)  
    Smart Reorg utility  
        control statement [150](#)  
PARTITION= [150](#), [383](#)  
partitioned database [383](#), [508](#), [509](#), [604](#), [605](#)  
partitioned secondary index [58](#), [104](#), [352](#)  
PARTSTAT=  
    YES [250](#), [401](#)  
PCB  
    feedback [467](#), [469](#)  
PCB= [462](#), [466](#), [475](#), [479](#)  
PCBLIST [468](#)  
PCBLIST= [475](#)  
PCBNAME= [462](#), [466](#), [475](#), [479](#)  
performance tips  
    IPR Reload utility [614](#)  
    IPR Unload utility [612](#)  
    Smart Reorg utility [609](#)  
PHDAM [110](#), [455](#)  
PHIDAM [110](#), [455](#)  
Physical Sequence Sort for Reload (PSSR) [579](#)  
PINDEX [259](#), [260](#)  
pipe [72](#), [151](#), [152](#)  
pipe ID [151](#), [152](#)  
PIPEBLKSZ= [151](#)  
PIPEDEPTH= [152](#)  
PIPEWAIT= [152](#)  
PLIRETC [582](#)  
policy [64](#)  
policy evaluation summary message [224](#)  
Policy Services [17](#)  
policy template [64](#)  
POLICYNM= [166](#)  
POSIX(ON) [582](#)  
post-reorganization processing [147](#)  
Post-reorganization utility [287](#)  
Pre-reorganization utility [287](#)

prefix resolution [153](#)  
Prefix Resolution and Update [75](#)  
prefix update [153](#)  
PREFIXRES=  
    YES [100](#), [102](#), [109](#)  
primary index  
    PHIDAM [110](#)  
PRINTRPRT= [166](#)  
procedure  
    IIUBSRT [49](#)  
process flow [21](#)  
PROCOPT [463](#), [469](#)  
PROGMON= [384](#), [525](#), [595](#)  
programming interface information [803](#)  
PROHIBIT AUTHORIZATION flag [72](#), [131](#), [149](#), [731](#), [735](#),  
[737](#)  
PSINDEX [58](#), [75](#)  
PSINDEXBLD=  
    YES [104](#)

## R

RAAF= [525](#)  
RAAFORMAT= [525](#)  
RANSIZE [392](#)  
RAP chain [398](#), [409](#), [435](#), [439–441](#), [505](#), [526](#), [560](#), [562](#),  
[630](#), [631](#), [636](#), [637](#)  
RAPCHAIN control statement [170](#)  
RAPCHAIN=  
    NO [526](#)  
    YES [560](#)  
RAPCHECK=  
    HDAM RAPCHECK Incorrect RAP Chain report [452](#)  
    HPSRAPC data set [363](#)  
RC\_CHANGE= [154](#)  
READ ONLY flag [72](#)  
reader comment form [34](#)  
RECNUM= [526](#)  
RECON data set [97](#), [259](#), [260](#), [363](#), [405](#), [406](#), [489](#), [589](#), [732](#),  
[739](#), [740](#)  
RECON data sets [495](#)  
RECOVABL [110](#), [138](#)  
REFT4 [392](#)  
region  
    DBB [466](#)  
    DLI [466](#)  
    ULU [462](#), [466](#)  
REGION parameter [151](#), [152](#)  
reloading in IMS-managed ACBs environment [538](#), [539](#)  
Reorganization Manager [70](#), [147](#)  
reorganization policy [64](#)  
reorganization scenario [85](#), [205](#), [211](#)  
reorganization tasks [72](#)  
REORGINPUT= [155](#)  
REPAIRILK= [526](#)  
REPL call [479](#)  
reports  
    IMS HP Image Copy [217](#)  
    IMS HP Pointer Checker [217](#)  
    IMS HP Prefix Resolution [217](#)  
    IMS Index Builder [217](#)  
return codes [661](#)  
RETURN-CODE [581](#)  
REUSE [489](#)

RMBSEGSZ= [527](#)  
RMNAME= [273](#), [419](#), [438](#), [488](#), [549](#), [561](#), [562](#)  
RSTRT statement [586](#)  
RTEXTIT= [402](#)  
rule template [64](#)  
runtime environment exit routine [402](#)  
runtime mode [55](#)

## S

SCEELKED [582](#)  
SCEERUN [582](#)  
screen readers and magnifiers [36](#)  
SEARCH=  
    -0 [560](#), [562](#)  
    0 [560](#), [562](#)  
    3 [527](#)  
secondary index  
    image copy [102](#), [103](#)  
    image copy data set [75](#)  
secondary indexes [108](#)  
SEGM statement [150](#), [372](#), [513](#)  
Segment Count Summary report [421](#)  
segment prefix [403](#)  
Segment Statistics report [428](#)  
SEGSEL= [385](#)  
SENSEG Statement [463](#)  
sensor data [65](#)  
SENSOR\_HOME= [166](#)  
seq\_buf\_amount [394](#)  
seq\_buf\_num [394](#)  
seq\_threshold [394](#)  
SEQERROR data set [281](#)  
SEQERROR=  
    ACCEPT [552](#)  
    SAVE [281](#), [514](#), [552](#), [663](#), [664](#)  
service information [34](#)  
shadow  
    data set [69](#), [104](#), [107](#)  
    database [69](#), [70](#), [72](#), [98](#), [104](#)  
    partition [69](#)  
SHISAM [110](#)  
SIDXBUF [175](#)  
SINDEX [259](#), [260](#)  
SINDEXSUF=  
    Installation Default Option Table [617](#)  
SKERROR= [402](#)  
SKIPAUTH= [386](#)  
SKIPERROR [357](#), [399](#), [400](#), [481](#), [482](#), [662](#)  
SKIPERROR=  
    1 [591](#)  
Smart Reorg  
    overview [55](#)  
Smart Reorg address space  
    non-swappable (SWAP=N) [90](#)  
    swappable (SWAP=Y) [90](#)  
Smart Reorg Driver [55](#), [57](#), [118](#)  
Smart Reorg utility [17](#), [50](#)  
SORT= [528](#)  
SORTFILSZ [175](#)  
SORTFSZ [175](#)  
SORTHIDAM= [530](#)  
SORTMAINSIZE [175](#)  
SORTOPT [175](#)

SPACEALLOC= [156](#)  
SSA [403](#)  
STARTDB= [158](#)  
STATREP= [386](#)  
STATRL=  
    YES [99](#)  
STATUL=  
    YES [99](#)  
status code [469](#)  
STATUS GROUPA [469](#)  
STDBRC [47](#)  
STEPLIB data sets [493](#), [588](#)  
STOPPED, NOT OPEN [140](#)  
STOPRUN [581](#)  
STORERPRT= [167](#)  
summary message [224](#)  
summary of changes [3](#)  
support information [34](#)  
SVCDUMP [175](#)  
SWAP= [90](#), [359](#), [413](#), [492](#), [543](#), [587](#)  
syntax diagrams  
    how to read [651](#)  
SYSALLDA [131](#)  
SYSUDUMP data set [499](#), [593](#)  
SYSUT1 data set [379](#)  
SYSUT2 data set [167](#), [364](#)  
SYSUT3 data set [364](#)  
SYSUT4 data set [364](#)

## T

tasks  
    Image Copy [69](#), [102](#), [138](#)  
    Index Builder [72](#), [143](#)  
    Prefix Resolution [176](#)  
    Reload [72](#), [159](#)  
    Unload [72](#), [160](#)  
technotes [34](#)  
temporary data set  
    dynamic allocation [131](#)  
timestamp  
    IC [110](#)  
    image copy [110](#)  
    REORG [110](#)  
TMRWAIT [175](#)  
TOSI [141](#)  
TOSITEST= [160](#)  
TOSIWAIT= [160](#)  
TOSIXCFGRP= [161](#), [162](#)  
TRACE [99](#)  
TRACE= [403](#)  
trademarks [803](#)  
TWINSTAT= [530](#)  
TYPE00 records [604](#)  
TYPE02 records [604](#)  
TYPE10 records [604](#)  
TYPE20 records [605](#)  
TYPE30 records [605](#)

## U

Unconditional Reorganization mode [55](#)  
unload data set format [351](#)

unloaded data formats [377](#), [378](#)  
UNLOADONLY example [202](#)  
UNLOADONLY= [161](#)  
user abend code  
    3999 [664](#)  
    4013 [664](#)  
user exit  
    IPR Reload utility [485](#), [579](#)  
    Type-A [353](#), [378](#), [455](#)  
    Type-B [353](#), [375](#), [378](#), [455](#), [456](#)  
USERHDR [352](#), [506](#)  
USERHDR= [387](#), [531](#)  
USERHDRX= [532](#)  
Utility Control Facility (UCF) [488](#)

## V

VIC=  
    N [110](#)  
    Y [110](#), [268](#)  
VICNAME [110](#)  
virtual LPCK [356](#)  
VSAM  
    cluster name [104](#), [107](#), [261](#)  
    component name [104](#), [107](#), [147](#), [212](#), [261](#)

## W

WF1DSN= [533](#)  
WF1REC= [533](#)  
WF1SPACE= [533](#)  
WF1UNIT= [534](#)  
WF1VOL= [534](#)  
WFP Process Summary report [253](#), [575](#)  
WFPHLQ= [534](#)  
WFPSPACE= [535](#)  
WFPUNIT= [535](#)  
WFPVOL= [535](#)  
WFPVOLCNT= [536](#)  
what's new [3](#)  
WORKHLQ= [310](#)  
WORKUNIT= [310](#)  
WORKVOL= [310](#)

## Z

ZIIPMODE= [404](#), [536](#)









Product Number: 5655-S35

SC19-1137-12

