

IBM TRIRIGA Application Platform
Version 4 Release 4

*Connector for Business Applications
SOAP API Technical Specification*



Note

Before using this information and the product it supports, read the information in “Notices” on page 120.

This edition applies to version 4, release 4, of IBM® TRIRIGA® Application Platform and to all subsequent releases and modifications until otherwise indicated in new editions.

© Copyright International Business Machines Corporation 2011, 2023. All rights reserved.

US Government Users Restricted Rights - Use, duplication or disclosure restricted by GSA ADP Schedule Contract with IBM Corp.

Contents

ABOUT THIS GUIDE	1
Conventions.....	1
Intended Audience.....	1
Prerequisites.....	2
Support.....	2
1. ARCHITECTURE	3
Diagram.....	3
WSDL Location	4
Getting Started	4
SOAP	4
Apache CXF	4
Authentication	5
Single Sign On.....	5
Authorization	5
Form Validation	5
Data Binding	6
MTOM Enablement	6
Error Handling	6
CustomBusinessConnectTask for Integrations.....	7
Duration Format.....	7
Tips when creating clients.....	7
2. METHODS	11
acceptActionItems	11
associateRecords	11

deassociateRecords	13
deleteCurrencyConversionRates	14
getActionItems	15
getAllAssociatedRecords	16
getApplicationInfo	17
getAssociatedRecords	18
getAssociationDefinitions	19
getAssociationDefinitionsByName	20
getAvailableActions	20
getChildren	21
getCurrencies	22
getCurrencyConversionGroups	23
getCurrencyConversionRates	24
getDefaultGUI	25
getDefaultGUIActions	27
getDefaultGuiId	28
getDefaultGuiStructure	29
getGUI	31
getGUIs	33
getGUIsByName	35
getGUIStateTransitions	36
getHierarchyMetadata	37
getHierarchyMetadataByModuleId	40
getHierarchyMetadataByModuleName	41
getHttpSession	41
getListByTypes	42
getListItems	43
getModuleId	44
getModules	45
getNamedQueryType	46

getObjectType.....	47
getObjectTypeActions	49
getObjectTypeByName	51
getObjectTypeId	53
getObjectTypeListByModuleId.....	54
getObjectTypeListByModuleName.....	55
getProjectId.....	56
getProjects.....	56
getRecordDataHeaders	57
getRecordState.....	58
getRequiredGuiFieldNames	59
getRootRecordId	61
getTargetRecords	62
getUserLicenses	63
putCurrencyConversionRates	64
register	66
runDynamicQuery.....	66
runDynamicQueryContinue	68
runNamedMetricQuery	70
runNamedMetricQueryContinue.....	72
runNamedQuery.....	74
runNamedQueryContinue	78
runNamedQueryMultiBo.....	82
runNamedQueryMultiBoContinue	85
runNamedQueryMultiBoLocalized	87
saveRecord	90
terminateSession	93
triggerActions	93
3. CONTENT.....	96

getContentFieldsDefinition	96
upload	97
download	99
copy	100
uploadFrom.....	101
downloadTo.....	102
delete	104
getContentLength.....	105
getChecksum.....	106
4. DATA TRANSFER OBJECTS GLOSSARY.....	108
ActionItem – submit/return.....	108
Association – submit/return.....	108
AssociationDefinition - return	108
ApplicationInfo – return.....	108
AssociationRecord – return	108
AvailableAction – return	109
ConversionGroup – return	109
Currency – return.....	109
CurrencyConversionRate – submit/return	109
ChildRecord – return	109
GUI – return	110
Tab - return.....	110
Section – return	110
Field – return	111
HierarchyObjectType - return	112
IntegrationRecord - submit	112
IntegrationSection – submit.....	112
IntegrationRows – submit.....	113
IntegrationField – submit	114

Module - return	114
ListType - return	114
ListItem – return	114
ObjectType – return.....	115
ObjectTypeAction - return	115
ObjectTypeActionStep - return.....	115
BaseObjectType – return.....	115
ResponseHelperHeader - return	116
ResponseHelper – return	116
Project - return	116
Record – return	116
QueryResult - return.....	117
QueryResponseHelper - return	117
QueryResponseColumn - return	117
ContinuationToken - return	117
DisplayLabel – submit.....	117
FieldSortOrder - submit	117
Filter - submit	118
AssociationFilter - submit	119
TriggerActions – submit	119
HttpSession – return.....	119
Transition – return	119
SubAction – return	119
State – submit/return	119
NOTICES.....	120
Privacy Policy Considerations	121
Trademarks.....	122

About This Guide

The following sections give an overview of the IBM® TRIRIGA® Connector for Business Applications SOAP API, describe the conventions used in this technical specification, and present additional information to assist you in understanding this technical specification.

IBM TRIRIGA Connector for Business Applications builds upon existing IBM TRIRIGA technology to allow external systems to more easily communicate with IBM TRIRIGA applications. IBM TRIRIGA Connector for Business Applications provides a web service interface for updating or requesting information from the IBM TRIRIGA application. This web service interface can use any integration middleware solution that supports current web service standards and protocols. IBM TRIRIGA Connector for Business Applications allows external systems to insert or update information or retrieve query results from the IBM TRIRIGA applications. It uses the same business logic that is defined in the online application and validates that required fields are inserted and that read-only fields are not updated.

This *IBM TRIRIGA Connector for Business Applications Technical Specification* focuses on those features specific to IBM TRIRIGA and IBM TRIRIGA Connector for Business Applications. This guide is not a replacement for a standard programming or web service tools manual.

Conventions

This document uses the following conventions to ensure that it is as easy to read and understand as possible:



Note - A Note provides important information that you should know in addition to the standard details. Often, notes are used to make you aware of the results of actions.



Tip - A Tip adds insightful information that may help you use the system better.



Attention - An Attention notice indicates the possibility of damage to a program, device, system, or data.

Intended Audience

This document is for technical staff using IBM TRIRIGA Connector for Business Applications to communicate between IBM TRIRIGA applications and external systems. This document assumes that the user has sufficient knowledge of how to use and implement web service technologies, either with a middleware language such as the Java programming language or with a web service application that allows SOAP communication between disparate systems.

Prerequisites

Users of the IBM TRIRIGA Connector for Business Applications must have expert technical knowledge of the external systems with which IBM TRIRIGA Connector for Business Applications communicates, as well as at least a basic understanding of the technical elements of the IBM TRIRIGA Application Platform, such as modules, business objects, form objects, section types, field types, queries, and workflow.

Support

IBM Software Support provides assistance with product defects, answering FAQs, and performing rediscovery. View the IBM Software Support site at www.ibm.com/support.

1. Architecture

Diagram

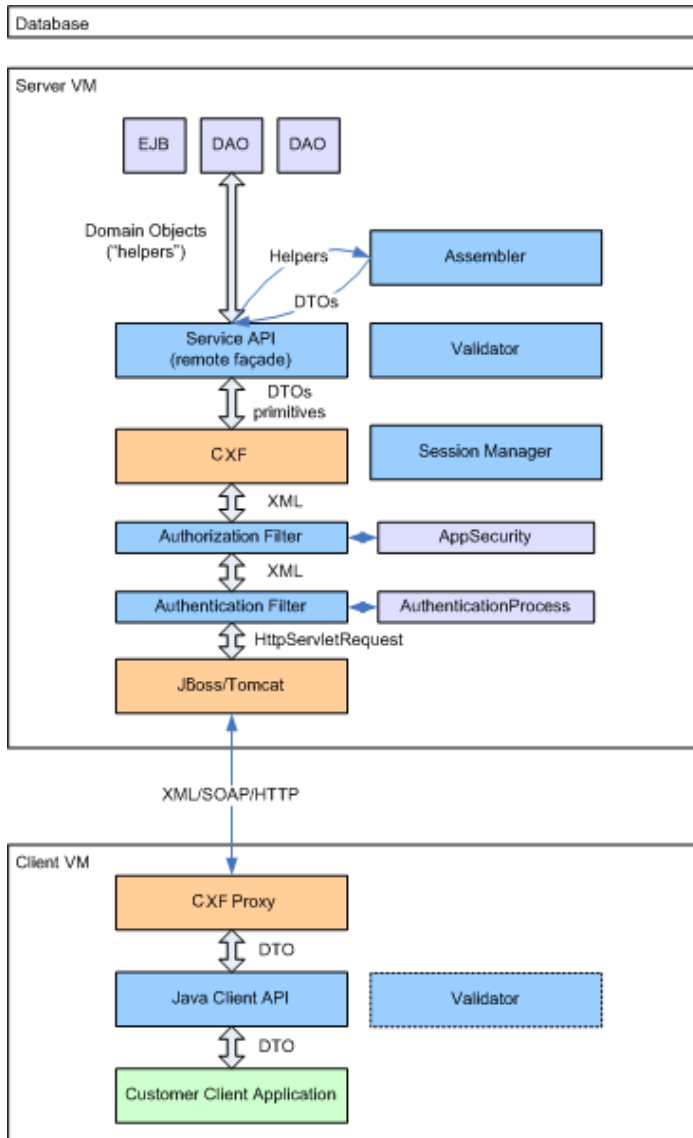

WSDL Location

The Web Service Description Language (WSDL) for this service can be retrieved from the IBM TRIRIGA server using the following URL: <http://your.local.server:port/ws/TririgaWS?wsdl>.

The WSDL defines all the methods and exceptions listed in this document. It allows the user to generate Java stubs or can be used in other environments like .Net or standard web services tools.

Getting Started

After making sure that you can retrieve the correct WSDL for the Connector Services, there are many options for continuing forward. IBM TRIRIGA Connector for Business Applications was developed with WS-I compliance in mind, so you can use third-party web services tools as clients or to develop interfaces for other environments. If you choose to develop using a programming language like Java, there is no need to marshal and unmarshal xml elements. You only need to handle true Java Objects.



Note - To avoid confusion during development of integrations using IBM TRIRIGA Connector for Business Applications, this document provides an introduction to how objects, section types, field types, and associations interact and work together. This document clarifies how most of the IBM TRIRIGA Connector for Business Applications objects relate to IBM TRIRIGA interoperability.

SOAP

SOAP (Simple Object Access Protocol) is a protocol for exchanging XML-based messages over a computer network, normally using HTTP. SOAP forms the foundation layer of the web services stack, providing a basic messaging framework upon which abstract layers can build. The original acronym was dropped with Version 1.2 of the standard, which became a W3C Recommendation on June 24, 2003, as it was considered to be misleading.

SOAP provides a way to communicate over HTTP between applications running on different operating systems, with different technologies and programming languages.

For more on SOAP and its technologies, refer to <http://www.w3.org/TR/soap/>

Apache CXF

The framework used to construct the IBM TRIRIGA Connector for Business Applications is Apache CXF, which is an open source framework for services. CXF supports SOAP web service standards. It is built on a low memory StAX based model. This is achieved by streaming the XML instead of caching the entire request in memory. This allows for very large data transfers, while keeping a low memory signature on the server. CXF uses the document-literal wrapped protocol. For more information about CXF, see <http://cxf.apache.org/>.

The supported CXF specifications are as follows. For more information about these specifications, see the Goals section at the following link: <http://cxf.apache.org/>.

- Basic support: WS-I Basic Profile 1.1

- Quality of Service: WS-Reliable Messaging
- Metadata: WSDL 1.1 - Web Service Definition Language
- Messaging Support: SOAP 1.2, Message Transmission Optimization Mechanism (MTOM)

CXF supports the February 2005 version of the Web Services Reliable Messaging (<http://schemas.xmlsoap.org/ws/2005/02/rm/>) Protocol (WS-ReliableMessaging) specification. By default, the Reliable Messaging Protocol is disabled on a TRIRIGA application server. In order to enable the Reliable Messaging Protocol, set the value of the `WS_RELIABLE_MESSAGING` property in `TRIRIGAWEB.properties` to `Y`. Other aspects of the Reliable Messaging Protocol can be configured in `TRIRIGAWEB.properties`, such as Delivery Assurance Type, which has a default value of `AtMostOnce`. For more information about `TRIRIGAWEB.properties`, go to the IBM TRIRIGA Application Platform product documentation and select *Installing IBM TRIRIGA Application Platform > Configuring the platform > Properties files*.

Authentication

Web Service requests include user credentials. The credentials in the request are authenticated using the same mechanism that the IBM TRIRIGA Application Platform uses for normal user login. By default, username and password will be sent using Http Basic Authentication. If the Http Basic Authentication is not found, it then checks the Http Header parameters for username and password. The user credentials will be authenticated and a session will be created on the server. On subsequent requests the service client maintains a session and the request will use the established session without requiring the password to be resent.

Single Sign On

If SSO is configured and enabled for the server, the user is authenticated and the session is created using the configured SSO mechanism. This means that authentication is the same for an IBM TRIRIGA Connector for Business Applications client as it is for a user using a web browser to access the server.

Authorization

Authorization will be determined by enforcing form level security as configured for the application.

Form Validation

The `saveRecord` method validates that the fields being submitted meet the default form validation. That is, if a required field is not filled in when a record is created, it does not allow the record to be saved. It throws an error and that submission fails. If the request is trying to save a read-only field, it throws an error and does not allow the request to save the record. You can check the form validation by making a request to the `getRequiredGuiFieldNames` method. It returns a `ResponseHelper` object that includes the name as `[sectionName]::[fieldName]` as the key and the value is 1 for Required, 2 for Read Only, or 3 for Required but in a Smart Section.

Attention - The value of the `ENFORCE_REQUIRED_VALIDATION` property has the potential to cause previously-working integrations to fail.



If set to the default of `Y`, the `ENFORCE_REQUIRED_VALIDATION` property in `TRIRIGAWEB.properties` ensures that a record cannot be created unless all required fields are validated, regardless of the tab in which the fields appear.

If set to `N`, the `ENFORCE_REQUIRED_VALIDATION` property in `TRIRIGAWEB.properties` enforces that a record cannot be created unless all required fields on the first tab are validated. This is the validation in versions of IBM TRIRIGA Application Platform before 3.0.

Data Binding

In order to pass objects over IBM TRIRIGA Connector for Business Applications, CXF handles the marshalling and unmarshalling of Java objects to their SOAP representations using the built-in data binding framework for CXF called Aegis. On the server side, the object passes through the Assembler class to convert objects from their domain (platform) representation to Data Transport Object and vice versa.

MTOM Enablement

The IBM TRIRIGA Connector for Business Applications Web Services component includes support for MTOM Enablement for certain operations. MTOM is a way to handle large amounts of binary data in your services. Unlike attachments, the XML infoset stays the same. MTOM optimizes any base64Binary data you have in your messages. With MTOM enabled, any base64 data is sent as a binary attachment, saving time and space.

Enabling MTOM allows content such as documents, images, and Rich Text Format note fields to be transferred via IBM TRIRIGA Connector for Business Applications.

When setting up a Web Services client, it is important to remember to configure the client to allow for MTOM as well or you may get unexpected results.

Error Handling

Method calls for IBM TRIRIGA Connector for Business Applications can throw exceptions in the form of faults. There are general exceptions that can be thrown by any request. Individual methods may throw exceptions specific to their functionality. For methods that accept batch records, the entire batch is returned as a response object appropriate for the method being called. The most common of these is a `ResponseHelperHeader` object. It contains a collection of the data submitted but with key data to identify each individual record and whether or not the record saved successfully or if there was an exception thrown. This way, if a batch is submitted, the request can keep track of exactly which records were affected positively or negatively.

The following exceptions can be thrown by any method request and are either thrown as a fault or are embedded as the error value for the response object.

Exception	Description
Authentication Exception	The request does not have a valid session established on the server and the authentication mechanism does not find a valid set of credentials in the HTTP parameters.
Authorization Exception	The authenticated user does not have permission to call the method in question.
Communications Exception	There was an error reading the request or writing the response.
Internal Server Error	There was an unexpected error and the server was unable to complete the request.
Invalid Input Data	Something in the input parameters is null, cannot be parsed, or is otherwise invalid. For example, if a method takes a record ID as a parameter and the ID contains non-numeric characters, this exception is thrown. This is different than the form validation for record data, which is handled individually by the GUI Data methods.

CustomBusinessConnectTask for Integrations

The workflow engine contains a task called CustomTask that exposes the Java methods used for the IBM TRIRIGA Connector for Business Applications. By taking advantage of this process, the full scoping capabilities of IBM TRIRIGA Connector for Business Applications can be triggered from a workflow using the Java layer and removing the overhead of SOAP marshalling/unmarshalling. This opens the door for event-triggered integrations. For more detailed information, see the *Application Building for the IBM TRIRIGA Application Platform*.

Duration Format

Duration is stored in the IBM TRIRIGA database as a long value. Use the following format to ensure your users see the correct value for durations in forms. The formula is as follows:

```
(1000000000000000 * ((years * 12) + months)) + (weeks * 604800000) + (days * 86400000) + (hours * 3600000) + (minutes * 60000) + (seconds * 1000) + milliseconds
```

Tips when creating clients

If you are creating stubs with the CXF wsdl2java tool, or if you are using a version of IBM TRIRIGA Connector for Business Applications from a platform release prior to IBM TRIRIGA Application Platform 3.3.1, you may find the following information useful:

Apache CXF Wsdl2Java Stub Generation Tool

There are known CXF stub creation issues in CXF versions before 2.6.4. You can avoid the issues when you generate client stubs by using the CXF 2.6.x `wsdl2java.bat` stub creation tool version 2.6.4 or later. There is information about the issue in CXF versions before 2.6.4 at the following website: <https://issues.apache.org/jira/browse/CXF-4598>. The known issue causes the following warning message: `WARNING: src-resolve.4.2: Error resolving component 'ns0:DataType'. It was detected that 'ns0:DataType' is in namespace 'http://dto.ws.tririga.com', but components from this namespace are not referenceable from schema document.`

You can avoid the following `WSDLToJava` error by setting the `-autoNameResolution` flag in the CXF `wsdl2java.bat` stub-creation tool. The issue causes the following warning message:

`WSDLToJava Error: Parameter: content already exists for method delete but of type com.tririga.ws.dto.content.Content instead of com.tririga.ws.dto.content.Response. Use a JAXWS/JAXB binding customization to rename the parameter.`

When running the `wsdl2java` command, a `java > lang` directory may be automatically created in the output directory where the stub/client code is generated. This directory can either be physically deleted or you can remove it from the classpath of your java project.

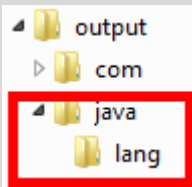

Open the generated `com.tririga.ws.Exception` class and add the following `@XMLType` annotation to the top of the class: `@XmlType(name = "Exception", namespace = "http://ws.tririga.com")`

For example,

```
@WebFault(name = "Exception", targetNamespace = "http://ws.tririga.com")
@XmlType(name = "Exception", namespace = "http://ws.tririga.com")
public class Exception extends java.lang.Exception {
```

Open the generated `com.tririga.ws.TririgaWSPortType` interface and remove the occurrence of `java.lang.ObjectFactory` from the `@XMLSeeAlso` annotation.

For example,

```
@WebService(targetNamespace = "http://ws.tririga.com", name =
"TririgaWSPortType")
@XmlSeeAlso({com.tririga.ws.dto.gui.ObjectFactory.class,
ObjectFactory.class, com.tririga.ws.dto.ObjectFactory.class,
com.tririga.ws.errors.ObjectFactory.class, java.lang.ObjectFactory.class,
com.tririga.ws.dto.content.ObjectFactory.class})

public interface TririgaWSPortType {
```

Axis2 Wsd2Java Stub Generation Tool

If you are using the Axis2 Wsd2Java stub generation tool, note that the wsdl starting with IBM TRIRIGA Application Platform version 3.3.1 is different from prior platform versions. Apache CXF places a ComplexType name on each IBM TRIRIGA Connector for Business Applications operation in the wsdl.

This change in the wsdl does not affect Axis2 client code for stubs that were generated from versions of IBM TRIRIGA Application Platform before 3.3.1. This change only affects your code for Axis2 stubs generated with 3.3.1 or later versions. Please keep this in mind if you are regenerating Axis2 stubs created before IBM TRIRIGA Application Platform 3.3.1.

```
<xsd:element name="runNamedQuery" type="tns:runNamedQuery" />
- <xsd:complexType name="runNamedQuery">
- <xsd:sequence>
  <xsd:element minOccurs="0" name="projectName"
nillable="true" type="xsd:string" />
  <xsd:element minOccurs="0" name="moduleName"
type="xsd:string" />
  <xsd:element minOccurs="0" name="objectTypeName"
type="xsd:string" />
  <xsd:element minOccurs="0" name="queryName"
type="xsd:string" />
  <xsd:element name="filters" nillable="true"
type="ns0:ArrayOfFilter" />
  <xsd:element name="start" type="xsd:int" />
  <xsd:element name="maximumResultCount" type="xsd:int" />
</xsd:sequence>
</xsd:complexType>
<xsd:element name="runNamedQueryResponse"
type="tns:runNamedQueryResponse" />
- <xsd:complexType name="runNamedQueryResponse">
- <xsd:sequence>
  <xsd:element minOccurs="0" name="out" type="ns0:QueryResult"
/>
</xsd:sequence>
</xsd:complexType>
```

The addition of the ComplexType name causes the Axis2 Wsd2Java stub generation tool to generate stubs in Expanded Mode. There are two client classes created for each IBM TRIRIGA Connector for Business Applications operation: A SoapStruct class and an Element class. The Element class is usually appended with the letter E.

The following is an example what the client code can look like for newly generated stubs on Axis2:

```
//Element class instance.
com.tririga.ws.TririgaWSStub.RunNamedQueryE runNamedQueryE =
    new com.tririga.ws.TririgaWSStub.RunNamedQueryE();

//SoapStruct bean instance
com.tririga.ws.TririgaWSStub.RunNamedQuery runNamedQuery =
    new com.tririga.ws.TririgaWSStub.RunNamedQuery();

//Set parameters to SoapStruct bean
runNamedQuery.setModuleName("Location");
runNamedQuery.setQueryName("Location - Find - All Active Building
```

Axis2 Wsd2Java Stub Generation Tool

```
and Floors");
```

```
//Set the SoapStruct bean to the element class instance.  
runNamedQueryE.setRunNamedQuery(runNamedQuery);
```

```
//run stub method  
stub.runNamedQuery(runNamedQueryE);
```

Known issues with Axis2 client code for stubs generated on versions of IBM TRIRIGA Application Platform before 3.3.1

Due to Apache XFire limitations regarding java inheritance, with Apache CXF framework, the wsdl starting with IBM TRIRIGA Application Platform version 3.3.1 is different from prior platform versions. Starting with IBM TRIRIGA Application Platform version 3.3.1, the wsdl contains an extension element for classes that extend a parent class.

The following example from the wsdl shows the extension element:

```
- <xsd:complexType name="QueryResult">  
  - <xsd:complexContent>  
    - <xsd:extension base="tns:AbstractQueryResult">  
      - <xsd:sequence>  
        <xsd:element minOccurs="0" name="queryResponseHelpers"  
          nillable="true" type="tns:ArrayOfQueryResponseHelper" />  
      </xsd:sequence>  
    </xsd:extension>  
  </xsd:complexContent>  
</xsd:complexType>
```

This may cause Unexpected SubElement exceptions on client calls from a wsdl from a version of IBM TRIRIGA Application Platform before 3.3.1. Either modify your Axis2 client code accordingly or regenerate your Axis2 stubs.

IBM TRIRIGA Connector for Business Applications class elements that may have this issue include the following:

- Association
- ChildRecord
- HierarchyObjectType
- ObjectType
- QueryMultiBoResult
- QueryMultiBoResponsColumn
- QueryResponseHelper
- QueryResult
- QueryMultiBoResponseHelper
- RecordSection
- Response

2. Methods

The following sections are descriptions of the methods available in the Web Service.

acceptActionItems

Description:

Accepts the given action items as belonging to the currently authenticated user.

Parameters:

actionItems - Array of ActionItem object to be accepted

Throws:

ActionItemInvalidException - Thrown if one of the given action items does not exist or otherwise cannot be accepted by this user

java.lang.Exception - If a system error occurred while processing the request

InvalidArgumentException - Thrown if any of the arguments passed in are invalid Exception

Sample Request:

```
<soapenv:Envelope
  xmlns:soapenv="http://schemas.xmlsoap.org/soap/envelope/"
  xmlns:ws="http://ws.tririga.com"
  xmlns:dto="http://dto.ws.tririga.com">
  <soapenv:Body>
    <ws:acceptActionItems>
      <ws>ActionItems>
        <dto>ActionItem>
          <dto:taskId>12345</dto:taskId>
          <dto:workflowId>12345</dto:workflowId>
        </dto>ActionItem>
      </ws>ActionItems>
    </ws:acceptActionItems>
  </soapenv:Body>
</soapenv:Envelope>
```

Sample Response:

There is no response for this method. The Request is successful if no Faults are thrown.

associateRecords

Description:

This creates an association between two records. If a reverse association is defined for this forward association, the reverse association will be created too.

Parameters:

associations - An array of Association objects to create

Returns:

ResponseHelperHeader - The status of the association that was passed in

Throws:

java.lang.Exception - Thrown if a problem occurs with any of the individual associations, or if a system error occurred while processing the request
 ModuleDoesNotExistException - Thrown if the given module does not exist
 ObjectTypeDoesNotExistException - Thrown if the given object type does not exist
 RecordDoesNotExistException - Thrown if the record passed in does not exist
 InvalidArgumentException - Thrown if any of the arguments passed in are invalid
 Exception
 AccessException - Thrown if the user does not have access to modify the record

Sample Request:

```

<soapenv:Envelope
  xmlns:soapenv="http://schemas.xmlsoap.org/soap/envelope/"
  xmlns:ws="http://ws.tririga.com"
  xmlns:dto="http://dto.ws.tririga.com">
  <soapenv:Body>
    <ws:associateRecords>
      <ws:Associations>
        <!--Zero or more repetitions:-->
        <dto:Association>
          <dto:associatedRecordId>12346</dto:associatedRecordId>
          <dto:associationName>Associated To</dto:associationName>
          <dto:recordId>12345</dto:recordId>
        </dto:Association>
      </ws:Associations>
    </ws:associateRecords>
  </soapenv:Body>
</soapenv:Envelope>
  
```

Sample Response:

```

<soap:Envelope
  xmlns:soap="http://schemas.xmlsoap.org/soap/envelope/"
  xmlns:xsd="http://www.w3.org/2001/XMLSchema"
  xmlns:xsi="http://www.w3.org/2001/XMLSchema-instance">
  <soap:Body>
    <associateRecordsResponse xmlns="http://ws.tririga.com">
      <out>
        <anyFailed xmlns="http://dto.ws.tririga.com">false</anyFailed>
        <failed xmlns="http://dto.ws.tririga.com">0</failed>
        <responseHelpers xmlns="http://dto.ws.tririga.com">
          <ResponseHelper>
            <key xsi:nil="true"/>
            <name>12346_Associated To_12345</name>
            <recordId>12346</recordId>
            <status>Successful</status>
            <value xsi:nil="true"/>
          </ResponseHelper>
        </responseHelpers>
        <successful xmlns="http://dto.ws.tririga.com">1</successful>
        <total xmlns="http://dto.ws.tririga.com">1</total>
      </out>
    </associateRecordsResponse>
  </soap:Body>
</soap:Envelope>
  
```

deassociateRecords

Description:

Delete specified associations between two records.

Parameters:

associations - An array of Association objects to delete

Returns:

ResponseHelperHeader - The status of the deassociation for each object

Throws:

java.lang.Exception - Thrown if a problem occurs with any of the individual associations, or if a system error occurred while processing the request

ModuleDoesNotExistException - Thrown if the given module does not exist

ObjectTypeDoesNotExistException - Thrown if the given object type does not exist

RecordDoesNotExistException - Thrown if the record passed in does not exist

InvalidArgumentException - Thrown if any of the arguments passed in are invalid Exception

AccessException - Thrown if the user does not have access to modify the record

Sample Request:

```
<soapenv:Envelope
  xmlns:soapenv="http://schemas.xmlsoap.org/soap/envelope/"
  xmlns:ws="http://ws.tririga.com"
  xmlns:dto="http://dto.ws.tririga.com">
  <soapenv:Body>
    <ws:deassociateRecords>
      <ws:Associations>
        <!--Zero or more repetitions:-->
        <dto:Association>
          <dto:associatedRecordId>12346</dto:associatedRecordId>
          <dto:associationName>Associated To</dto:associationName>
          <dto:recordId>12345</dto:recordId>
        </dto:Association>
      </ws:Associations>
    </ws:deassociateRecords>
  </soapenv:Body>
</soapenv:Envelope>
```

Sample Response:

```
<soap:Envelope
  xmlns:soap="http://schemas.xmlsoap.org/soap/envelope/"
  xmlns:xsd="http://www.w3.org/2001/XMLSchema"
  xmlns:xsi="http://www.w3.org/2001/XMLSchema-instance">
  <soap:Body>
    <deassociateRecordsResponse xmlns="http://ws.tririga.com">
      <out>
        <anyFailed xmlns="http://dto.ws.tririga.com">false</anyFailed>
        <failed xmlns="http://dto.ws.tririga.com">0</failed>
        <responseHelpers xmlns="http://dto.ws.tririga.com">
          <ResponseHelper>
            <key xsi:nil="true"/>
            <name>12346_Associated To_12345</name>
            <recordId>12346</recordId>
            <status>Successful</status>
```

```

        <value xsi:nil="true"/>
    </ResponseHelper>
</responseHelpers>
<successful xmlns="http://dto.ws.tririga.com">1</successful>
<total xmlns="http://dto.ws.tririga.com">1</total>
</out>
</deassociateRecordsResponse>
</soap:Body>
</soap:Envelope>

```

deleteCurrencyConversionRates

Description:

This deletes specified currency conversion rates. Only future conversion rates can be deleted (i.e., where the start date is greater than the current system time).

Parameters:

IDs - The instance IDs of the rates to delete

Returns:

ResponseHelperHeader - Contains an Array of ResponseHelper objects to signal which records were successful and which ones failed, or could not be deleted, because start date is in the past. Also, it contains quick retrieve info about failures, successes, and total records submitted.

Throws:

InvalidArgumentException - If any of the conversion rate instance IDs are invalid (none will be deleted in this case)

java.lang.Exception - If a system error occurred while processing the request

AccessException - Thrown if the user does not have access to Currency Conversion Manager

Sample Request:

```

<soapenv:Envelope
  xmlns:soapenv="http://schemas.xmlsoap.org/soap/envelope/"
  xmlns:ws="http://ws.tririga.com">
  <soapenv:Body>
    <ws:deleteCurrencyConversionRates>
      <ws:conversionRateIds>
        <!--Zero or more repetitions-->
        <ws:long>12345</ws:long>
      </ws:conversionRateIds>
    </ws:deleteCurrencyConversionRates>
  </soapenv:Body>
</soapenv:Envelope>

```

Sample Response:

```

<soap:Envelope
  xmlns:soap="http://schemas.xmlsoap.org/soap/envelope/"
  xmlns:xsd="http://www.w3.org/2001/XMLSchema"
  xmlns:xsi="http://www.w3.org/2001/XMLSchema-instance">
  <soap:Body>
    <deleteCurrencyConversionRatesResponse xmlns="http://ws.tririga.com">
      <out>

```

```

<anyFailed xmlns="http://dto.ws.tririga.com">false</anyFailed>
<failed xmlns="http://dto.ws.tririga.com">0</failed>
<responseHelpers xmlns="http://dto.ws.tririga.com">
  <ResponseHelper>
    <key xsi:nil="true"/>
    <name>12345</name>
    <recordId>-1</recordId>
    <status xsi:nil="true"/>
    <value>Successful</value>
  </ResponseHelper>
</responseHelpers>
<successful xmlns="http://dto.ws.tririga.com">1</successful>
<total xmlns="http://dto.ws.tririga.com">1</total>
</out>
</deleteCurrencyConversionRatesResponse>
</soap:Body>
</soap:Envelope>

```

getActionItems

Description:

Get the Action Items in the queue associated with the user ID of the current session

Returns:

An array of ActionItem objects for the user

Throws:

java.lang.Exception - If a system error occurred while processing the request

Sample Request:

```

<soapenv:Envelope
  xmlns:soapenv="http://schemas.xmlsoap.org/soap/envelope/"
  xmlns:ws="http://ws.tririga.com">
  <soapenv:Body>
    <ws:getActionItems/>
  </soapenv:Body>
</soapenv:Envelope>

```

Sample Response:

```

<soap:Envelope
  xmlns:soap="http://schemas.xmlsoap.org/soap/envelope/"
  xmlns:xsd="http://www.w3.org/2001/XMLSchema"
  xmlns:xsi="http://www.w3.org/2001/XMLSchema-instance">
  <soap:Body>
    <getActionItemsResponse xmlns="http://ws.tririga.com">
      <out>
        <ns1:ActionItem xmlns:ns1="http://dto.ws.tririga.com">
          <taskId xmlns="http://dto.ws.tririga.com">193826</taskId>
          <workflowId xmlns="http://dto.ws.tririga.com">14335629</workflowId>
        </ns1:ActionItem>
        <ns1:ActionItem xmlns:ns1="http://dto.ws.tririga.com">
          <taskId xmlns="http://dto.ws.tririga.com">193826</taskId>
          <workflowId xmlns="http://dto.ws.tririga.com">14335529</workflowId>
        </ns1:ActionItem>
      </out>
    </getActionItemsResponse>
  </soap:Body>
</soap:Envelope>

```

```
    </ns1:ActionItem>
  </out>
</getActionItemsResponse>
</soap:Body>
</soap:Envelope>
```

getAllAssociatedRecords

Description:

Get records associated to the given recordIds though the given association.

Parameters:

recordIds - Array of recordIds

associationString - Association string filter. Leave empty String "" to follow all associations.

maxResults - The maximum number of results to return, -1 for all

Returns:

Array of AssociationRecord objects limited by maxResults if applicable.

Throws:

RecordDoesNotExistException - Thrown if the given context record does not exist

InvalidArgumentException - Thrown if any of the arguments passed in are invalid

java.lang.Exception - if a system error occurred while processing the request

AccessException - Thrown if the user does not have access to the record

Sample Request:

```
<soapenv:Envelope
  xmlns:soapenv="http://schemas.xmlsoap.org/soap/envelope/"
  xmlns:ws="http://ws.tririga.com">
  <soapenv:Body>
    <ws:getAllAssociatedRecords>
      <ws:recordIds>
        <!--Zero or more repetitions:-->
        <ws:long>12345</ws:long>
      </ws:recordIds>
      <ws:associationString></ws:associationString>
      <ws:maxResults>-1</ws:maxResults>
    </ws:getAllAssociatedRecords>
  </soapenv:Body>
</soapenv:Envelope>
```

Sample Response:

```
<soap:Envelope
  xmlns:soap="http://schemas.xmlsoap.org/soap/envelope/"
  xmlns:xsd="http://www.w3.org/2001/XMLSchema"
  xmlns:xsi="http://www.w3.org/2001/XMLSchema-instance">
  <soap:Body>
    <getAllAssociatedRecordsResponse xmlns="http://ws.tririga.com">
      <out>
        <ns1:AssociationRecord xmlns:ns1="http://dto.ws.tririga.com">
          <associations xmlns="http://dto.ws.tririga.com">
            <Association>
              <associatedModuleId>109876</associatedModuleId>
              <associatedObjectTypeId>1001234</associatedObjectTypeId>
```

```

    <associatedRecordId>12346</associatedRecordId>
    <associatedRecordName>RecordName</associatedRecordName>
    <associationName>Primary Location</associationName>
    <inverseAssociationName/>
    <moduleName>Location</moduleName>
    <objectTypeName>triSpace</objectTypeName>
    <recordId>12345</recordId>
    <reverseAssociationName/>
    <sourceModuleId>1002301</sourceModuleId>
    <sourceObjectTypeId>100112345</sourceObjectTypeId>
  </Association>
</associations>
  <recordId xmlns="http://dto.ws.tririga.com">12345</recordId>
</ns1:AssociationRecord>
</out>
</getAllAssociatedRecordsResponse>
</soap:Body>
</soap:Envelope>

```

getApplicationInfo

Description:

Get information about the version of the application and database, as well as the IBM TRIRIGA Connector for Business Applications version

Returns:

ApplicationInfo Object

Throws:

java.lang.Exception - if a system error occurred while processing the request

Sample Request:

```

<soapenv:Envelope
  xmlns:soapenv="http://schemas.xmlsoap.org/soap/envelope/"
  xmlns:ws="http://ws.tririga.com">
  <soapenv:Body>
    <ws:getApplicationInfo/>
  </soapenv:Body>
</soapenv:Envelope>

```

Sample Response:

```

<soap:Envelope
  xmlns:soap="http://schemas.xmlsoap.org/soap/envelope/"
  xmlns:xsd="http://www.w3.org/2001/XMLSchema"
  xmlns:xsi="http://www.w3.org/2001/XMLSchema-instance">
  <soap:Body>
    <getApplicationInfoResponse xmlns="http://ws.tririga.com">
      <out>
        <apiVersion xmlns="http://dto.ws.tririga.com">2</apiVersion>
        <dbBuildNumber xmlns="http://dto.ws.tririga.com">30146</dbBuildNumber>
        <tririgaBuildNumber xmlns="http://dto.ws.tririga.com">30146</tririgaBuildNumber>
      </out>
    </getApplicationInfoResponse>
  </soap:Body>

```



```
</soap:Envelope>
```

getAssociatedRecords

Description:

Get records associated with the given record through the given association. This method functions exactly as the getAllAssociatedRecords method, except it only takes one recordId instead of an array.

Parameters:

recordId - The source record for the association

association - Name of the association to follow, use empty String "" to follow all associations

maxResults - The maximum number of results to return, -1 for all

Returns:

An array of Association objects limited by maxResults if applicable

Throws:

RecordDoesNotExistException - If the given context record does not exist

InvalidArgumentException - If any of the arguments passed in are invalid

java.lang.Exception - If a system error occurred while processing the request

Sample Request:

```
<soapenv:Envelope
  xmlns:soapenv="http://schemas.xmlsoap.org/soap/envelope/"
  xmlns:ws="http://ws.tririga.com">
  <soapenv:Body>
    <ws:getAssociatedRecords>
      <ws:recordId>2592271</ws:recordId>
      <ws:associationString></ws:associationString>
      <ws:maxResults>-1</ws:maxResults>
    </ws:getAssociatedRecords>
  </soapenv:Body>
</soapenv:Envelope>
```

Sample Response:

```
<soap:Envelope
  xmlns:soap="http://schemas.xmlsoap.org/soap/envelope/"
  xmlns:xsd="http://www.w3.org/2001/XMLSchema"
  xmlns:xsi="http://www.w3.org/2001/XMLSchema-instance">
  <soap:Body>
    <getAssociatedRecordsResponse xmlns="http://ws.tririga.com">
      <out>
        <ns1:Association xmlns:ns1="http://dto.ws.tririga.com">
          <associatedModuleId xmlns="http://dto.ws.tririga.com">6</associatedModuleId>
          <associatedObjectTypeId
            xmlns="http://dto.ws.tririga.com">10002873</associatedObjectTypeId>
          <associatedRecordId
            xmlns="http://dto.ws.tririga.com">2544355</associatedRecordId>
          <associatedRecordName
            xmlns="http://dto.ws.tririga.com">test0.006383329817522099</associatedRecordName>
          <associationName
            xmlns="http://dto.ws.tririga.com">Primary
            Location</associationName>
          <inverseAssociationName xmlns="http://dto.ws.tririga.com"/>
        </ns1:Association>
      </out>
    </getAssociatedRecordsResponse>
  </soap:Body>
</soap:Envelope>
```

```

    <moduleName xmlns="http://dto.ws.tririga.com">Location</moduleName>
    <objectTypeName xmlns="http://dto.ws.tririga.com">triSpace</objectTypeName>
    <recordId xmlns="http://dto.ws.tririga.com">2592271</recordId>
    <reverseAssociationName xmlns="http://dto.ws.tririga.com"/>
    <sourceModuleId xmlns="http://dto.ws.tririga.com">22219</sourceModuleId>
    <sourceObjectTypeId
xmlns="http://dto.ws.tririga.com">10010138</sourceObjectTypeId>
    </ns1:Association>
  </out>
</getAssociatedRecordsResponse>
</soap:Body>
</soap:Envelope>

```

getAssociationDefinitions

Description:

Get the association definitions that exist for the specified object type

Parameters:

objectTypeId - a valid object type ID (>0)

Returns:

An array of AssociationDefinition objects for the given object type

Throws:

ObjectTypeDoesNotExistException - If the object specified by objectTypeId does not exist

InvalidArgumentException - If objectTypeId ≤ 0

java.lang.Exception - If a system error occurred while processing the request

AccessException - Thrown if the user does not have access to the business object

Sample Request:

```

<soapenv:Envelope
  xmlns:soapenv="http://schemas.xmlsoap.org/soap/envelope/"
  xmlns:ws="http://ws.tririga.com">
  <soapenv:Body>
    <ws:getAssociationDefinitions>
      <ws:objectTypeId>10002873</ws:objectTypeId>
    </ws:getAssociationDefinitions>
  </soapenv:Body>
</soapenv:Envelope>

```

Sample Response:

```

<soap:Envelope
  xmlns:soap="http://schemas.xmlsoap.org/soap/envelope/"
  xmlns:xsd="http://www.w3.org/2001/XMLSchema"
  xmlns:xsi="http://www.w3.org/2001/XMLSchema-instance">
  <soap:Body>
    <getAssociationDefinitionsResponse xmlns="http://ws.tririga.com">
      <out>
        <ns1:AssociationDefinition xmlns:ns1="http://dto.ws.tririga.com">
          <associatedModuleId xmlns="http://dto.ws.tririga.com">21</associatedModuleId>
          <associatedObjectTypeId
xmlns="http://dto.ws.tririga.com">10000323</associatedObjectTypeId>

```

```

        <associationName xmlns="http://dto.ws.tririga.com">Food Service
Contract</associationName>
        <inverseAssociationName xmlns="http://dto.ws.tririga.com">Food Service Contract
For</inverseAssociationName>
        <moduleName xsi:nil="true" xmlns="http://dto.ws.tririga.com"/>
        <objectTypeName xsi:nil="true" xmlns="http://dto.ws.tririga.com"/>
        <sourceModuleId xmlns="http://dto.ws.tririga.com">6</sourceModuleId>
        <sourceObjectId
xmlns="http://dto.ws.tririga.com">10002873</sourceObjectId>
        </ns1:AssociationDefinition> </out>
    </getAssociationDefinitionsResponse>
</soap:Body>
</soap:Envelope>

```

getAssociationDefinitionsByName

Description:

Get the association definitions that are connected to a specified object type. Exactly the same as getAssociationDefinitions, except instead of using the objectId, use the Module name and ObjectType name.

Parameters:

moduleName - module that the object type belongs to
objectTypeName - name of the object type

Returns:

An array of AssociationDefinition objects for the given object type

Throws:

ObjectTypeDoesNotExistException - If the object specified by moduleName and objectTypeName does not exist in module moduleName
InvalidArgumentException - If moduleName or objectTypeName is null or an empty String
java.lang.Exception - If a system error occurred while processing the request
AccessException - Thrown if the user does not have access to the business object

Sample Request/Response: see getAssociationDefinitions

getAvailableActions

Description:

Method to retrieve the current state of each object specified in the recordId array. It will also return all the available, callable state transitions and their subAction information.

Parameters:

recordIds - Array of the recordIds you need the state transition information for.

Returns:

An array of AvailableAction objects

Throws:

InvalidArgumentException - Thrown if the recordIds are invalid
java.lang.Exception - Thrown if a system error occurred while processing the request.

AccessException - Thrown if the user does not have access to the record

Sample Request:

```
<soapenv:Envelope
  xmlns:soapenv="http://schemas.xmlsoap.org/soap/envelope/"
  xmlns:ws="http://ws.tririga.com">
  <soapenv:Body>
    <ws:getAvailableActions>
      <ws:recordIds>
        <!--Zero or more repetitions:-->
        <ws:long>2592271</ws:long>
      </ws:recordIds>
    </ws:getAvailableActions>
  </soapenv:Body>
</soapenv:Envelope>
```

Sample Response:

```
<soap:Envelope
  xmlns:soap="http://schemas.xmlsoap.org/soap/envelope/"
  xmlns:xsd="http://www.w3.org/2001/XMLSchema"
  xmlns:xsi="http://www.w3.org/2001/XMLSchema-instance">
  <soap:Body>
    <getAvailableActionsResponse xmlns="http://ws.tririga.com">
      <out>
        <ns1:AvailableAction xmlns:ns1="http://dto.ws.tririga.com">
          <availableTransitions xmlns="http://dto.ws.tririga.com">
            <Transition>
              <action>Apply</action>
              <actionId>0</actionId>
              <actionSequence>750212</actionSequence>
              <label>Save</label>
              <nextState xsi:nil="true"/>
              <subActions xsi:nil="true"/>
            </Transition>
          </availableTransitions>
          <currentState xmlns="http://dto.ws.tririga.com">Active</currentState>
          <recordId xmlns="http://dto.ws.tririga.com">2592271</recordId>
        </ns1:AvailableAction>
      </out>
    </getAvailableActionsResponse>
  </soap:Body>
</soap:Envelope>
```

getChildren

Description:

Get the records that are children of the record with a specified ID

Parameters:

recordId - ID for which to return children

Returns:

An array of ChildRecord objects

Throws:

RecordDoesNotExistException - If the input record ID does not exist

InvalidArgumentException - If the record ID is invalid

java.lang.Exception - If a system error occurred while processing the request

AccessException - Thrown if the user does not have access to the record

Sample Request:

```
<soapenv:Envelope
  xmlns:soapenv="http://schemas.xmlsoap.org/soap/envelope/"
  xmlns:ws="http://ws.tririga.com">
  <soapenv:Body>
    <ws:getChildren>
      <ws:recordId>213004</ws:recordId>
    </ws:getChildren>
  </soapenv:Body>
</soapenv:Envelope>
```

Sample Response:

```
<soap:Envelope
  xmlns:soap="http://schemas.xmlsoap.org/soap/envelope/"
  xmlns:xsd="http://www.w3.org/2001/XMLSchema"
  xmlns:xsi="http://www.w3.org/2001/XMLSchema-instance">
  <soap:Body>
    <getChildrenResponse xmlns="http://ws.tririga.com">
      <out>
        <ns1:ChildRecord xmlns:ns1="http://dto.ws.tririga.com">
          <childCount xmlns="http://dto.ws.tririga.com">1</childCount>
          <currentState xsi:nil="true" xmlns="http://dto.ws.tririga.com"/>
          <description xsi:nil="true" xmlns="http://dto.ws.tririga.com"/>
          <guild xmlns="http://dto.ws.tririga.com">-1</guild>
          <guiName xsi:nil="true" xmlns="http://dto.ws.tririga.com"/>
          <id xmlns="http://dto.ws.tririga.com">2535762</id>
          <moduleId xmlns="http://dto.ws.tririga.com">-1</moduleId>
          <name xsi:nil="true" xmlns="http://dto.ws.tririga.com"/>
          <objectPath xsi:nil="true" xmlns="http://dto.ws.tririga.com"/>
          <objectTypeId xmlns="http://dto.ws.tririga.com">10002100</objectTypeId>
          <objectTypeName xmlns="http://dto.ws.tririga.com">triBuilding</objectTypeName>
          <parentId xmlns="http://dto.ws.tririga.com">0</parentId>
          <path xmlns="http://dto.ws.tririga.com">Locations\My Building</path>
          <sections xmlns="http://dto.ws.tririga.com"/>
          <tabs xsi:nil="true" xmlns="http://dto.ws.tririga.com"/>
        </ns1:ChildRecord>
      </out>
    </getChildrenResponse>
  </soap:Body>
</soap:Envelope>
```

getCurrencies

Description:

Get a list of the currencies available in the system

Returns:

A list of the currencies available in the system

Throws:

java.lang.Exception - If a system error occurred while processing the request

AccessException - Thrown if the user does not have access to Currency Conversion Manager

Sample Request:

```
<soapenv:Envelope
  xmlns:soapenv="http://schemas.xmlsoap.org/soap/envelope/"
  xmlns:ws="http://ws.tririga.com">
  <soapenv:Body>
    <ws:getCurrencies/>
  </soapenv:Body>
</soapenv:Envelope>
```

Sample Response:

```
<soap:Envelope
  xmlns:soap="http://schemas.xmlsoap.org/soap/envelope/"
  xmlns:xsd="http://www.w3.org/2001/XMLSchema"
  xmlns:xsi="http://www.w3.org/2001/XMLSchema-instance">
  <soap:Body>
    <getCurrenciesResponse xmlns="http://ws.tririga.com">
      <out>
        <ns1:Currency xmlns:ns1="http://dto.ws.tririga.com">
          <abbreviation xmlns="http://dto.ws.tririga.com">USD</abbreviation>
          <decimal xmlns="http://dto.ws.tririga.com">.</decimal>
          <delimiter xmlns="http://dto.ws.tririga.com">,</delimiter>
          <format xmlns="http://dto.ws.tririga.com">###,###.00</format>
          <name xmlns="http://dto.ws.tririga.com">US Dollars</name>
          <symbol xmlns="http://dto.ws.tririga.com">$</symbol>
        </ns1:Currency>
      </out>
    </getCurrenciesResponse>
  </soap:Body>
</soap:Envelope>
```

getCurrencyConversionGroups

Description:

Get a list of all allowed currency conversion groups

Returns:

A list of all allowed currency conversion groups

Throws:

java.lang.Exception - If a system error occurred while processing the request

AccessException - Thrown if the user does not have access to Currency Conversion Manager

Sample Request:

```
<soapenv:Envelope
  xmlns:soapenv="http://schemas.xmlsoap.org/soap/envelope/"
  xmlns:ws="http://ws.tririga.com">
  <soapenv:Body>
```

```
<ws:getCurrencyConversionGroups/>
</soapenv:Body>
</soapenv:Envelope>
```

Sample Response:

```
<soap:Envelope
  xmlns:soap="http://schemas.xmlsoap.org/soap/envelope/"
  xmlns:xsd="http://www.w3.org/2001/XMLSchema"
  xmlns:xsi="http://www.w3.org/2001/XMLSchema-instance">
  <soap:Body>
    <getCurrencyConversionGroupsResponse xmlns="http://ws.tririga.com">
      <out>
        <ns1:ConversionGroup xmlns:ns1="http://dto.ws.tririga.com">
          <id xmlns="http://dto.ws.tririga.com">1009705</id>
          <name xmlns="http://dto.ws.tririga.com">Default</name>
        </ns1:ConversionGroup>
      </out>
    </getCurrencyConversionGroupsResponse>
  </soap:Body>
</soap:Envelope>
```

getCurrencyConversionRates

Get a list of all of the currency conversion rates in the system

Returns:

A list of the currency conversion rates currently in the system

Throws:

java.lang.Exception - If a system error occurred while processing the request

AccessException - Thrown if the user does not have access to Currency Conversion Manager

Sample Request:

```
<soapenv:Envelope
  xmlns:soapenv="http://schemas.xmlsoap.org/soap/envelope/"
  xmlns:ws="http://ws.tririga.com">
  <soapenv:Body>
    <ws:getCurrencyConversionRates/>
  </soapenv:Body>
</soapenv:Envelope>
```

Sample Response:

```
<soap:Envelope
  xmlns:soap="http://schemas.xmlsoap.org/soap/envelope/"
  xmlns:xsd="http://www.w3.org/2001/XMLSchema"
  xmlns:xsi="http://www.w3.org/2001/XMLSchema-instance">
  <soap:Body>
    <getCurrencyConversionRatesResponse xmlns="http://ws.tririga.com">
      <out>
        <ns1:CurrencyConversionRate xmlns:ns1="http://dto.ws.tririga.com">
          <conversionGroup xmlns="http://dto.ws.tririga.com">Default</conversionGroup>
          <conversionRate xmlns="http://dto.ws.tririga.com">1.8</conversionRate>
          <endDate xmlns="http://dto.ws.tririga.com">2006-04-19T16:15:10-07:00</endDate>
        </ns1:CurrencyConversionRate>
      </out>
    </getCurrencyConversionRatesResponse>
  </soap:Body>
</soap:Envelope>
```

```

    <frequencyGroup xmlns="http://dto.ws.tririga.com">Daily</frequencyGroup>
    <fromCurrency xmlns="http://dto.ws.tririga.com">Canada Dollars</fromCurrency>
    <id xmlns="http://dto.ws.tririga.com">1402</id>
    <startDate xmlns="http://dto.ws.tririga.com">2006-04-18T16:15:10-
07:00</startDate>
    <toCurrency xmlns="http://dto.ws.tririga.com">US Dollars</toCurrency>
  </ns1:CurrencyConversionRate>
</out>
</getCurrencyConversionRatesResponse>
</soap:Body>
</soap:Envelope>

```

getDefaultGUI

Description:

Get the metadata for the default GUI for a specific record

Parameters:

recordId - The record ID for which to retrieve the default GUI

Returns:

The default GUI object for the given record

Throws:

RecordDoesNotExistException - If a record with the specified ID does not exist

GuiDoesNotExistException - If the record does not have a default GUI associated with it

java.lang.Exception - If a system error occurred while processing the request

AccessException - Thrown if the user does not have access to the form or record

Sample Request:

```

<soapenv:Envelope
  xmlns:soapenv="http://schemas.xmlsoap.org/soap/envelope/"
  xmlns:ws="http://ws.tririga.com">
  <soapenv:Body>
    <ws:getDefaultGUI>
      <ws:recordId>2535762</ws:recordId>
    </ws:getDefaultGUI>
  </soapenv:Body>
</soapenv:Envelope>

```

Sample Response: (condensed)

```

<soap:Envelope
  xmlns:soap="http://schemas.xmlsoap.org/soap/envelope/"
  xmlns:xsd="http://www.w3.org/2001/XMLSchema"
  xmlns:xsi="http://www.w3.org/2001/XMLSchema-instance">
  <soap:Body>
    <getDefaultGUIResponse xmlns="http://ws.tririga.com">
      <out>
        <childRecordId xmlns="http://gui.dto.ws.tririga.com">0</childRecordId>
        <id xmlns="http://gui.dto.ws.tririga.com">10002954</id>
        <label xmlns="http://gui.dto.ws.tririga.com">Building</label>
        <moduleId xmlns="http://gui.dto.ws.tririga.com">6</moduleId>
        <moduleName xmlns="http://gui.dto.ws.tririga.com">Location</moduleName>
        <name xmlns="http://gui.dto.ws.tririga.com">triBuilding</name>
      </out>
    </getDefaultGUIResponse>
  </soap:Body>
</soap:Envelope>

```



```

<objectTypeId xmlns="http://gui.dto.ws.tririga.com">10002100</objectTypeId>
<objectTypeName
xmlns="http://gui.dto.ws.tririga.com">triBuilding</objectTypeName>
<popupId xmlns="http://gui.dto.ws.tririga.com">0</popupId>
<recordId xmlns="http://gui.dto.ws.tririga.com">2535762</recordId>
<recordName xmlns="http://gui.dto.ws.tririga.com">My Building</recordName>
<saveOnPopup xmlns="http://gui.dto.ws.tririga.com">>false</saveOnPopup>
<singleTab xmlns="http://gui.dto.ws.tririga.com">>false</singleTab>
<state xmlns="http://gui.dto.ws.tririga.com">triRevision</state>
<tabs xmlns="http://gui.dto.ws.tririga.com">
  <Tab>
    <id>9999</id>
    <instruction xsi:nil="true"/>
    <label xsi:nil="true"/>
    <name>System Info</name>
    <sections>
      <Section>
        <fields>
          <Field>
            <dataType xsi:nil="true"/>
            <displayValue xsi:nil="true"/>
            <guiRootClassificationId>0</guiRootClassificationId>
            <guiRootClassificationName xsi:nil="true"/>
            <guiSectionId>0</guiSectionId>
            <guiSectionName xsi:nil="true"/>
            <label>Review Status</label>
            <listId>0</listId>
            <listModuleId>0</listModuleId>
            <liveLink>>false</liveLink>
            <locatorField>>false</locatorField>
            <locatorModuleId>0</locatorModuleId>
            <mobileField>>false</mobileField>
            <mobileFieldSeq>0</mobileFieldSeq>
            <name>Review Status</name>
            <readOnly>>false</readOnly>
            <refObjectTypeId>0</refObjectTypeId>
            <refSpecId>0</refSpecId>
            <required>>false</required>
            <rootClassification>~</rootClassification>
            <rootClassificationId>0</rootClassificationId>
            <sectionName>System Info</sectionName>
            <specId>2535762</specId>
            <type>Text</type>
            <unitOfMeasure/>
            <unitOfMeasureType>0</unitOfMeasureType>
            <value/>
          </Field>
        </fields>
      </Section>
    </sections>
  </Tab>
</tabs>
</state>
</singleTab>
</saveOnPopup>
</recordName>
</recordId>
</popupId>
</objectTypeName>
</objectTypeId>

```

```

        <rows xsi:nil="true"/>
        <type>GUI Section</type>
        <typeld>0</typeld>
        <visible>>false</visible>
    </Section>        </sections>
    <tabInformation>triRevision</tabInformation>
    <url xsi:nil="true"/>
    <visible>>false</visible>
</Tab>
</tabs>
<type xmlns="http://gui.dto.ws.tririga.com">Wizard</type>
</out>
</getDefaultGUIResponse>
</soap:Body>
</soap:Envelope>

```

getDefaultGUIActions

Description:

Method to get the default GUI actions for a new Record

Parameters:

guild - The ID of the GUI to retrieve

Returns:

Array of Transition Objects.

Throws:

GuiDoesNotExistException - If a GUI with the given ID does not exist. Also thrown if the user does not have access to the form

java.lang.Exception - if a system error occurred while processing the request

Sample Request:

```

<soapenv:Envelope
  xmlns:soapenv="http://schemas.xmlsoap.org/soap/envelope/"
  xmlns:ws="http://ws.tririga.com">
  <soapenv:Body>
    <ws:getDefaultGUIActions>
      <ws:guild>10002954</ws:guild>
    </ws:getDefaultGUIActions>
  </soapenv:Body>
</soapenv:Envelope>

```

Sample Response:

```

<soap:Envelope
  xmlns:soap="http://schemas.xmlsoap.org/soap/envelope/"
  xmlns:xsd="http://www.w3.org/2001/XMLSchema"
  xmlns:xsi="http://www.w3.org/2001/XMLSchema-instance">
  <soap:Body>
    <getDefaultGUIActionsResponse xmlns="http://ws.tririga.com">
      <out>
        <ns1:Transition xmlns:ns1="http://dto.ws.tririga.com">
          <action xmlns="http://dto.ws.tririga.com">triCreateDraft</action>

```

```

    <actionId xmlns="http://dto.ws.tririga.com">1</actionId>
    <actionSequence xmlns="http://dto.ws.tririga.com">0</actionSequence>
    <label xmlns="http://dto.ws.tririga.com">Create Draft</label>
    <nextState xmlns="http://dto.ws.tririga.com">triDraft</nextState>
    <subActions xsi:nil="true" xmlns="http://dto.ws.tririga.com"/>
  </ns1:Transition>
</out>
</getDefaultGUIActionsResponse>
</soap:Body>
</soap:Envelope>

```

getDefaultGuild

Description:

Get the default GUI id for the given Object Type

Parameters:

objectTypeId - the id of the object type

Returns:

The id of the gui

Throws:

ObjectTypeDoesNotExistException - if the objectTypeId is invalid

InvalidArgumentException - If the record ID is invalid

java.lang.Exception - If a system error occurred while processing the request

AccessException - Thrown if the user does not have access to the business object

Sample Request:

```

<soapenv:Envelope
  xmlns:soapenv="http://schemas.xmlsoap.org/soap/envelope/"
  xmlns:ws="http://ws.tririga.com">
  <soapenv:Body>
    <ws:getDefaultGuild>
      <ws:objectTypeId>10002100</ws:objectTypeId>
    </ws:getDefaultGuild>
  </soapenv:Body>
</soapenv:Envelope>

```

Sample Response:

```

<soap:Envelope
  xmlns:soap="http://schemas.xmlsoap.org/soap/envelope/"
  xmlns:xsd="http://www.w3.org/2001/XMLSchema"
  xmlns:xsi="http://www.w3.org/2001/XMLSchema-instance">
  <soap:Body>
    <getDefaultGuildResponse xmlns="http://ws.tririga.com">
      <out>10002954</out>
    </getDefaultGuildResponse>
  </soap:Body>
</soap:Envelope>

```

getDefaultGuiStructure

Description:

Get the default GUI structure for the given Object Type

Parameters:

objectTypeId - the id of the object type

Returns:

The GUI structure of the GUI

Throws:

ObjectTypeDoesNotExistException - Thrown if the given object type does not exist
InvalidArgumentException - Thrown if any of the arguments passed in are invalid
Exception java.lang.Exception - If a system error occurred while processing the request
AccessException - Thrown if the user does not have access to the form

Sample Request:

```
<soapenv:Envelope
  xmlns:soapenv="http://schemas.xmlsoap.org/soap/envelope/"
  xmlns:ws="http://ws.tririga.com">
  <soapenv:Header/>
  <soapenv:Body>
    <ws:getDefaultGuiStructure>
      <ws:objectTypeId>10013946</ws:objectTypeId>
    </ws:getDefaultGuiStructure>
  </soapenv:Body>
</soapenv:Envelope>
```

Sample Response: (compressed)

```
<soap:Envelope
  xmlns:soap="http://schemas.xmlsoap.org/soap/envelope/"
  xmlns:xsd="http://www.w3.org/2001/XMLSchema"
  xmlns:xsi="http://www.w3.org/2001/XMLSchema-instance">
  <soap:Body>
    <getDefaultGuiStructureResponse xmlns="http://ws.tririga.com">
      <out>
        <childRecordId xmlns="http://gui.dto.ws.tririga.com">0</childRecordId>
        <id xmlns="http://gui.dto.ws.tririga.com">10021547</id>
        <label xmlns="http://gui.dto.ws.tririga.com">Application Settings</label>
        <moduleId xmlns="http://gui.dto.ws.tririga.com">20621</moduleId>
        <moduleName xmlns="http://gui.dto.ws.tririga.com">triSetup</moduleName>
        <name xmlns="http://gui.dto.ws.tririga.com">triApplicationSettings</name>
        <objectTypeId xmlns="http://gui.dto.ws.tririga.com">10013946</objectTypeId>
        <objectTypeName
xmlns="http://gui.dto.ws.tririga.com">triApplicationSettings</objectTypeName>
        <popupId xmlns="http://gui.dto.ws.tririga.com">0</popupId>
        <recordId xmlns="http://gui.dto.ws.tririga.com">-1</recordId>
        <recordName xmlns="http://gui.dto.ws.tririga.com"/>
        <saveOnPopup xmlns="http://gui.dto.ws.tririga.com">>false</saveOnPopup>
        <singleTab xmlns="http://gui.dto.ws.tririga.com">>false</singleTab>
        <state xmlns="http://gui.dto.ws.tririga.com"/>
        <tabs xmlns="http://gui.dto.ws.tririga.com">
          <Tab>
            <id>1</id>
```

```

<instruction>Required</instruction>
<label>General</label>
<name>triGeneral</name>
<sections>
  <Section>
    <fields>
      <Field>
        <dataType xsi:nil="true"/>
        <displayValue xsi:nil="true"/>
        <guiRootClassificationId>-1</guiRootClassificationId>
        <guiRootClassificationName xsi:nil="true"/>
        <guiSectionId>1</guiSectionId>
        <guiSectionName xsi:nil="true"/>
        <label>Attention!</label>
        <listId>0</listId>
        <listModuleId>0</listModuleId>
        <liveLink>>false</liveLink>
        <locatorField>>false</locatorField>
        <locatorModuleId>0</locatorModuleId>
        <mobileField>>false</mobileField>
        <mobileFieldSeq>0</mobileFieldSeq>
        <name>triUserMessageTX</name>
        <readOnly>>true</readOnly>
        <refObjectTypeId>0</refObjectTypeId>
        <refSpecId>0</refSpecId>
        <required>>false</required>
        <rootClassification xsi:nil="true"/>
        <rootClassificationId>0</rootClassificationId>
        <sectionName>General</sectionName>
        <specId>0</specId>
        <type>Text</type>
        <unitOfMeasure xsi:nil="true"/>
        <unitOfMeasureType>0</unitOfMeasureType>
        <value xsi:nil="true"/>
      </Field>
    </fields>
    <guiSectionId>3</guiSectionId>
    <guiSectionName>triRecordInformation</guiSectionName>
    <id>-1</id>
    <label>Record Information</label>
    <name xsi:nil="true"/>
    <readOnly>>false</readOnly>
    <refModuleId>0</refModuleId>
    <refObjectTypeId>0</refObjectTypeId>
    <rows xsi:nil="true"/>
    <type>GUI Section</type>
    <typeId>0</typeId>
    <visible>>false</visible>
  </Section>
</sections>
<tabInformation xsi:nil="true"/>
<url xsi:nil="true"/>
<visible>>true</visible>
</Tab>
</tabs>

```

```

    <type xmlns="http://gui.dto.ws.tririga.com">Wizard</type>
  </out>
</getDefaultGUIStructureResponse>
</soap:Body>
</soap:Envelope>

```

getGUI

Description:

Get GUI metadata for a given GUI ID and record ID

Parameters:

guild - The ID of the GUI to retrieve

recordId - The ID of the record whose GUI we should retrieve. -1 for just the structure

Returns:

The metadata for the GUI

Throws:

RecordDoesNotExistException - If a record with the given ID does not exist

GuiDoesNotExistException - If a GUI with the given ID does not exist

java.lang.Exception - If a system error occurred while processing the request

AccessException - Thrown if the user does not have access to the form, or record if applicable

Sample Request:

```

<soapenv:Envelope
  xmlns:soapenv="http://schemas.xmlsoap.org/soap/envelope/"
  xmlns:ws="http://ws.tririga.com">
  <soapenv:Body>
    <ws:getGUI>
      <ws:guild>10015638</ws:guild>
      <ws:recordId>2592371</ws:recordId>
    </ws:getGUI>
  </soapenv:Body>
</soapenv:Envelope>

```

Sample Response: (Condensed)

```

<soap:Envelope
  xmlns:soap="http://schemas.xmlsoap.org/soap/envelope/"
  xmlns:xsd="http://www.w3.org/2001/XMLSchema"
  xmlns:xsi="http://www.w3.org/2001/XMLSchema-instance">
  <soap:Body>
    <getGUIResponse xmlns="http://ws.tririga.com">
      <out>
        <childRecordId xmlns="http://gui.dto.ws.tririga.com">0</childRecordId>
        <id xmlns="http://gui.dto.ws.tririga.com">10015638</id>
        <label xmlns="http://gui.dto.ws.tririga.com">ProjectWFTest</label>
        <moduleId xmlns="http://gui.dto.ws.tririga.com">22219</moduleId>
        <moduleName xmlns="http://gui.dto.ws.tririga.com">_rrTest</moduleName>
        <name xmlns="http://gui.dto.ws.tririga.com">ProjectWFTest</name>
        <objectTypeId xmlns="http://gui.dto.ws.tririga.com">10010138</objectTypeId>
        <objectTypeName
  xmlns="http://gui.dto.ws.tririga.com">ProjectWFTest</objectTypeName>

```

```

<popupId xmlns="http://gui.dto.ws.tririga.com">0</popupId>
<recordId xmlns="http://gui.dto.ws.tririga.com">2592371</recordId>
<recordName xmlns="http://gui.dto.ws.tririga.com">SampleInstance-
12345</recordName>
<saveOnPopup xmlns="http://gui.dto.ws.tririga.com">>false</saveOnPopup>
<singleTab xmlns="http://gui.dto.ws.tririga.com">>false</singleTab>
<state xmlns="http://gui.dto.ws.tririga.com">Start</state>
<tabs xmlns="http://gui.dto.ws.tririga.com">
  <Tab>
    <id>1</id>
    <instruction xsi:nil="true"/>
    <label xsi:nil="true"/>
    <name>General</name>
    <sections>
      <Section>
        <fields>
          <Field>
            <dataType xsi:nil="true"/>
            <displayValue xsi:nil="true"/>
            <guiRootClassificationId>0</guiRootClassificationId>
            <guiRootClassificationName xsi:nil="true"/>
            <guiSectionId>0</guiSectionId>
            <guiSectionName xsi:nil="true"/>
            <label>Topic</label>
            <listId>0</listId>
            <listModuleId>0</listModuleId>
            <liveLink>>false</liveLink>
            <locatorField>>false</locatorField>
            <locatorModuleId>0</locatorModuleId>
            <mobileField>>false</mobileField>
            <mobileFieldSeq>0</mobileFieldSeq>
            <name>Name</name>
            <readOnly>>false</readOnly>
            <refObjectTypeId>0</refObjectTypeId>
            <refSpecId>0</refSpecId>
            <required>>true</required>
            <rootClassification>~</rootClassification>
            <rootClassificationId>0</rootClassificationId>
            <sectionName>General</sectionName>
            <specId>2592371</specId>
            <type>Text</type>
            <unitOfMeasure/>
            <unitOfMeasureType>0</unitOfMeasureType>
            <value>SampleInstance</value>
          </Field>
          <Field>
            <dataType xsi:nil="true"/>
            <displayValue xsi:nil="true"/>
            <guiRootClassificationId>0</guiRootClassificationId>
            <guiRootClassificationName xsi:nil="true"/>
            <guiSectionId>0</guiSectionId>
            <guiSectionName xsi:nil="true"/>
            <label>ID</label>
            <listId>-1</listId>
            <listModuleId>-1</listModuleId>

```

```

<liveLink>>false</liveLink>
<locatorField>>false</locatorField>
<locatorModuleId>0</locatorModuleId>
<mobileField>>false</mobileField>
<mobileFieldSeq>0</mobileFieldSeq>
<name>trildTX</name>
<readOnly>>false</readOnly>
<refObjectTypeId>0</refObjectTypeId>
<refSpecId>0</refSpecId>
<required>>false</required>
<rootClassification>~</rootClassification>
<rootClassificationId>-1</rootClassificationId>
<sectionName>General</sectionName>
<specId>2592371</specId>
<type>Text</type>
<unitOfMeasure/>
<unitOfMeasureType>-1</unitOfMeasureType>
<value>12345</value>
</Field>
</fields>
<guiSectionId>0</guiSectionId>
<guiSectionName xsi:nil="true"/>
<id>1</id>
<label>General</label>
<name>General</name>
<readOnly>>false</readOnly>
<refModuleId>0</refModuleId>
<refObjectTypeId>0</refObjectTypeId>
<rows xsi:nil="true"/>
<type>GUI Section</type>
<typeId>0</typeId>
<visible>>false</visible>
</Section>
</sections>
<tabInformation>Start</tabInformation>
<url xsi:nil="true"/>
<visible>>false</visible>
</Tab>
</tabs>
<type xmlns="http://gui.dto.ws.tririga.com">Wizard</type>
</out>
</getGUIResponse>
</soap:Body>
</soap:Envelope>

```

getGUIs

Description:

Get the metadata headers of all the GUIs for a particular object type. This lightweight method is useful for making a quick call to retrieve the GUI name or ids for use with other methods.



Note – This method filters out alternative forms that are retrieved. Alternative forms are not returned for selection on the GUI.

Parameters:

objectTypeld - ID of the object type

Returns:

An array of GUI objects, with the Tab data omitted.

Throws:

ObjectTypeDoesNotExistException - If there is no object type with the ID objectTypeld

InvalidArgumentException - If the objectTypeld<=0

java.lang.Exception - If a system error occurred while processing the request

Sample Request:

```
<soapenv:Envelope
  xmlns:soapenv="http://schemas.xmlsoap.org/soap/envelope/"
  xmlns:ws="http://ws.tririga.com">
  <soapenv:Body>
    <ws:getGUIs>
      <ws:objectTypeld>10010138</ws:objectTypeld>
    </ws:getGUIs>
  </soapenv:Body>
</soapenv:Envelope>
```

Sample Response:

```
<soap:Envelope
  xmlns:soap="http://schemas.xmlsoap.org/soap/envelope/"
  xmlns:xsd="http://www.w3.org/2001/XMLSchema"
  xmlns:xsi="http://www.w3.org/2001/XMLSchema-instance">
  <soap:Body>
    <getGUIsResponse xmlns="http://ws.tririga.com">
      <out>
        <ns1:GUI xmlns:ns1="http://gui.dto.ws.tririga.com">
          <childRecordId xmlns="http://gui.dto.ws.tririga.com">0</childRecordId>
          <id xmlns="http://gui.dto.ws.tririga.com">10015638</id>
          <label xmlns="http://gui.dto.ws.tririga.com">ProjectWFTest</label>
          <moduleId xmlns="http://gui.dto.ws.tririga.com">22219</moduleId>
          <moduleName xmlns="http://gui.dto.ws.tririga.com">_rrTest</moduleName>
          <name xmlns="http://gui.dto.ws.tririga.com">ProjectWFTest</name>
          <objectTypeld xmlns="http://gui.dto.ws.tririga.com">10010138</objectTypeld>
          <objectTypeName
xmlns="http://gui.dto.ws.tririga.com">ProjectWFTest</objectTypeName>
          <popupId xmlns="http://gui.dto.ws.tririga.com">0</popupId>
          <recordId xmlns="http://gui.dto.ws.tririga.com">0</recordId>
          <recordName xsi:nil="true" xmlns="http://gui.dto.ws.tririga.com"/>
          <saveOnPopup xmlns="http://gui.dto.ws.tririga.com">>false</saveOnPopup>
          <singleTab xmlns="http://gui.dto.ws.tririga.com">>false</singleTab>
          <state xsi:nil="true" xmlns="http://gui.dto.ws.tririga.com"/>
          <tabs xsi:nil="true" xmlns="http://gui.dto.ws.tririga.com"/>
          <type xmlns="http://gui.dto.ws.tririga.com">Wizard</type>
        </ns1:GUI>
      </out>
    </getGUIsResponse>
  </soap:Body>
</soap:Envelope>
```

```
</getGUIsResponse>
</soap:Body>
</soap:Envelope>
```

getGUIsByName

Description:

Get the metadata headers of all the GUIs for a particular object type. This lightweight method is useful for making a quick call to retrieve the GUI name or ids for use with other methods. This call is identical to the getGUIs method, except it takes in the String names of ObjectType and module instead of the objectTypeId.



Note – This method filters out alternative forms that are retrieved. Alternative forms are not returned for selection on the GUI.

Parameters:

objectTypeName - name of the object type to look up
moduleName - module name of the object type to look up

Returns:

An array of GUI objects

Throws:

ObjectTypeDoesNotExistException - If the object specified by objectTypeName and moduleName do not exist
InvalidArgumentException - If the objectTypeName or moduleName is null or an empty string
java.lang.Exception - If a system error occurred while processing the request

Sample Request:

```
<soapenv:Envelope
  xmlns:soapenv="http://schemas.xmlsoap.org/soap/envelope/"
  xmlns:ws="http://ws.tririga.com">
  <soapenv:Header/>
  <soapenv:Body>
    <ws:getGUIsByName>
      <ws:objectTypeName>Document</ws:objectTypeName>
      <ws:moduleName>Document</ws:moduleName>
    </ws:getGUIsByName>
  </soapenv:Body>
</soapenv:Envelope>
```

Sample Response:

```
<soap:Envelope
  xmlns:soap="http://schemas.xmlsoap.org/soap/envelope/"
  xmlns:xsd="http://www.w3.org/2001/XMLSchema"
  xmlns:xsi="http://www.w3.org/2001/XMLSchema-instance">
  <soap:Body>
    <getGUIsByNameResponse xmlns="http://ws.tririga.com">
      <out>
        <ns1:GUI xmlns:ns1="http://gui.dto.ws.tririga.com">
```

```

    <childRecordId xmlns="http://gui.dto.ws.tririga.com">0</childRecordId>
    <id xmlns="http://gui.dto.ws.tririga.com">106615</id>
    <label xmlns="http://gui.dto.ws.tririga.com">Document</label>
    <moduleId xmlns="http://gui.dto.ws.tririga.com">11</moduleId>
    <moduleName xmlns="http://gui.dto.ws.tririga.com">Document</moduleName>
    <name xmlns="http://gui.dto.ws.tririga.com">Document</name>
    <objectTypeId xmlns="http://gui.dto.ws.tririga.com">106615</objectTypeId>
    <objectTypeName
xmlns="http://gui.dto.ws.tririga.com">Document</objectTypeName>
    <popupId xmlns="http://gui.dto.ws.tririga.com">0</popupId>
    <recordId xmlns="http://gui.dto.ws.tririga.com">0</recordId>
    <recordName xsi:nil="true" xmlns="http://gui.dto.ws.tririga.com"/>
    <saveOnPopup xmlns="http://gui.dto.ws.tririga.com">false</saveOnPopup>
    <singleTab xmlns="http://gui.dto.ws.tririga.com">false</singleTab>
    <state xsi:nil="true" xmlns="http://gui.dto.ws.tririga.com"/>
    <tabs xsi:nil="true" xmlns="http://gui.dto.ws.tririga.com"/>
    <type xmlns="http://gui.dto.ws.tririga.com">Wizard</type>
  </ns1:GUI>
</out>
</getGUIsByNameResponse>
</soap:Body>
</soap:Envelope>

```

getGUIStateTransitions

Description:

Method to retrieve the entire GUI state transition tree for the given GUI object.

Parameters:

objectTypeId - the ID of the Object Type
 guild - the ID of the GUI from the Object Type

Returns:

An array of State objects.

Throws:

InvalidArgumentException - Thrown if the objectTypeId or guild are invalid.
 java.lang.Exception - If a system error occurred while processing the request
 AccessException - Thrown if the user does not have access to the form, or business object if applicable

Sample Request:

```

<soapenv:Envelope
  xmlns:soapenv="http://schemas.xmlsoap.org/soap/envelope/"
  xmlns:ws="http://ws.tririga.com">
  <soapenv:Body>
    <ws:getGUIStateTransitions>
      <ws:objectTypeId>106402</ws:objectTypeId>
      <ws:guild>10002361</ws:guild>
    </ws:getGUIStateTransitions>
  </soapenv:Body>
</soapenv:Envelope>

```

Sample Response:

```
<soap:Envelope
  xmlns:soap="http://schemas.xmlsoap.org/soap/envelope/"
  xmlns:xsd="http://www.w3.org/2001/XMLSchema"
  xmlns:xsi="http://www.w3.org/2001/XMLSchema-instance">
  <soap:Body>
    <getStateTransitionsResponse xmlns="http://ws.tririga.com">
      <out>
        <ns1:State xmlns:ns1="http://dto.ws.tririga.com">
          <recordId xmlns="http://dto.ws.tririga.com">-1</recordId>
          <state xmlns="http://dto.ws.tririga.com">null</state>
          <trans xmlns="http://dto.ws.tririga.com">
            <Transition>
              <action>triActivate</action>
              <actionId>1</actionId>
              <actionSequence>0</actionSequence>
              <label>Activate</label>
              <nextState>triReview</nextState>
              <subActions xsi:nil="true"/>
            </Transition>
            <Transition>
              <action>triCreateDraft</action>
              <actionId>1</actionId>
              <actionSequence>1</actionSequence>
              <label>Create Draft</label>
              <nextState>triDraft</nextState>
              <subActions xsi:nil="true"/>
            </Transition>
          </trans>
        </ns1:State>
      </out>
    </getStateTransitionsResponse>
  </soap:Body>
</soap:Envelope>
```

getHierarchyMetadata

Description:

This gets the permissible structure of the hierarchy that can be created from the object types in a hierarchy module. It specifies which object type must be used to create the record that is the root of the hierarchy. It also specifies what types of records can appear under each type of record.

Parameters:

moduleId - The module ID of the hierarchy module

objectTypeId - The object type ID of the object type that is used to create the hierarchy root record

Returns:

The hierarchy object type

Throws:

ModuleDoesNotExistException - If the module with ID moduleId does not exist in the system

InvalidArgumentException - If objectTypeId is not valid
java.lang.Exception - If a system error occurred while processing the request
AccessException - Thrown if the user does not have access to the business object

Sample Request:

```
<soapenv:Envelope
  xmlns:soapenv="http://schemas.xmlsoap.org/soap/envelope/"
  xmlns:ws="http://ws.tririga.com">
  <soapenv:Body>
    <ws:getHierarchyMetadata>
      <ws:moduleId>6</ws:moduleId>
      <ws:objectId>106403</ws:objectId>
    </ws:getHierarchyMetadata>
  </soapenv:Body>
</soapenv:Envelope>
```

Sample Response:

```
<soap:Envelope
  xmlns:soap="http://schemas.xmlsoap.org/soap/envelope/"
  xmlns:xsd="http://www.w3.org/2001/XMLSchema"
  xmlns:xsi="http://www.w3.org/2001/XMLSchema-instance">
  <soap:Body>
    <getHierarchyMetadataResponse xmlns="http://ws.tririga.com">
      <out>
        <childBaseObjectTypes xsi:nil="true" xmlns="http://dto.ws.tririga.com"/>
        <children xmlns="http://dto.ws.tririga.com">
          <HierarchyObjectType>
            <childBaseObjectTypes xsi:nil="true"/>
            <children>
              <HierarchyObjectType>
                <childBaseObjectTypes xsi:nil="true"/>
                <children>
                  <HierarchyObjectType>
                    <childBaseObjectTypes xsi:nil="true"/>
                    <children/>
                    <id>10008239</id>
                    <name>triVerticalShaft</name>
                    <rootOfHierarchy>>false</rootOfHierarchy>
                  </HierarchyObjectType>
                <HierarchyObjectType>
                  <childBaseObjectTypes xsi:nil="true"/>
                  <children/>
                  <id>10002873</id>
                  <name>triSpace</name>
                  <rootOfHierarchy>>false</rootOfHierarchy>
                </HierarchyObjectType>
              </children>
            <id>10002582</id>
            <name>triFloor</name>
            <rootOfHierarchy>>false</rootOfHierarchy>
          </HierarchyObjectType>
        </children>
      <id>10002599</id>
      <name>triProposedSite</name>
      <rootOfHierarchy>>false</rootOfHierarchy>
    </out>
  </getHierarchyMetadataResponse>
</soap:Body>
</soap:Envelope>
```

```

</HierarchyObjectType>
<HierarchyObjectType>
  <childBaseObjectTypes xsi:nil="true" />
  <children>
    <HierarchyObjectType>
      <childBaseObjectTypes xsi:nil="true" />
      <children/>
      <id>10002585</id>
      <name>triLand</name>
      <rootOfHierarchy>>false</rootOfHierarchy>
    </HierarchyObjectType>
    <HierarchyObjectType>
      <childBaseObjectTypes xsi:nil="true" />
      <children>
        <HierarchyObjectType>
          <childBaseObjectTypes xsi:nil="true" />
          <children/>
          <id>10008239</id>
          <name>triVerticalShaft</name>
          <rootOfHierarchy>>false</rootOfHierarchy>
        </HierarchyObjectType>
        <HierarchyObjectType>
          <childBaseObjectTypes xsi:nil="true" />
          <children>
            <HierarchyObjectType>
              <childBaseObjectTypes xsi:nil="true" />
              <children/>
              <id>10008239</id>
              <name>triVerticalShaft</name>
              <rootOfHierarchy>>false</rootOfHierarchy>
            </HierarchyObjectType>
            <HierarchyObjectType>
              <childBaseObjectTypes xsi:nil="true" />
              <children/>
              <id>10002873</id>
              <name>triSpace</name>
              <rootOfHierarchy>>false</rootOfHierarchy>
            </HierarchyObjectType>
          </children>
          <id>10002582</id>
          <name>triFloor</name>
          <rootOfHierarchy>>false</rootOfHierarchy>
        </HierarchyObjectType>
      </children>
      <id>10002100</id>
      <name>triBuilding</name>
      <rootOfHierarchy>>false</rootOfHierarchy>
    </HierarchyObjectType>
  </children>
  <id>10002586</id>
  <name>triProperty</name>
  <rootOfHierarchy>>false</rootOfHierarchy>
</HierarchyObjectType>
<HierarchyObjectType>
  <childBaseObjectTypes xsi:nil="true" />

```

```

<children/>
<id>10002585</id>
<name>triLand</name>
<rootOfHierarchy>>false</rootOfHierarchy>
</HierarchyObjectType>
<HierarchyObjectType>
  <childBaseObjectTypes xsi:nil="true"/>
  <children>
    <HierarchyObjectType>
      <childBaseObjectTypes xsi:nil="true"/>
      <children/>
      <id>10008239</id>
      <name>triVerticalShaft</name>
      <rootOfHierarchy>>false</rootOfHierarchy>
    </HierarchyObjectType>
    <HierarchyObjectType>
      <childBaseObjectTypes xsi:nil="true"/>
      <children>
        <HierarchyObjectType>
          <childBaseObjectTypes xsi:nil="true"/>
          <children/>
          <id>10008239</id>
          <name>triVerticalShaft</name>
          <rootOfHierarchy>>false</rootOfHierarchy>
        </HierarchyObjectType>
        <HierarchyObjectType>
          <childBaseObjectTypes xsi:nil="true"/>
          <children/>
          <id>10002873</id>
          <name>triSpace</name>
          <rootOfHierarchy>>false</rootOfHierarchy>
        </HierarchyObjectType>
      </children>
      <id>10002582</id>
      <name>triFloor</name>
      <rootOfHierarchy>>false</rootOfHierarchy>
    </HierarchyObjectType>
  </children>
  <id>10002100</id>
  <name>triBuilding</name>
  <rootOfHierarchy>>false</rootOfHierarchy>
</HierarchyObjectType>
</children>
<id xmlns="http://dto.ws.tririga.com">106403</id>
<name xmlns="http://dto.ws.tririga.com">Location</name>
<rootOfHierarchy xmlns="http://dto.ws.tririga.com">>true</rootOfHierarchy>
</out>
</getHierarchyMetadataResponse>
</soap:Body>
</soap:Envelope>

```

getHierarchyMetadataByModuleId

Description:

This gets the permissible structure of the hierarchy that can be created from the object types in a hierarchy module. It specifies which object type must be used to create the record that is the root of the hierarchy. It also specifies what types of records can appear under each type of record.

Parameters:

moduleId - The module ID of the hierarchy module

Returns:

The hierarchy object type

Throws:

ModuleDoesNotExistException - If the module with ID moduleId does not exist in the system

java.lang.Exception - If a system error occurred while processing the request

AccessException - Thrown if the user does not have access to the module

Sample Request / Response: Exactly the same as getHierarchyMetadata method.

getHierarchyMetadataByModuleName

Description:

This gets the permissible structure of the hierarchy that can be created from the object types in a hierarchy module. It specifies which object type must be used to create the record that is the root of the hierarchy. It also specifies what types of records can appear under each type of record.

Parameters:

moduleName - The module name whose hierarchy will be retrieved

Returns:

The hierarchy object type

Throws:

ModuleDoesNotExistException - If the module with ID moduleId does not exist in the system

java.lang.Exception - If a system error occurred while processing the request

AccessException - Thrown if the user does not have access to the module

Sample Request / Response: Exactly the same as getHierarchyMetadata method.

getHttpSession

Description:

Method to get the Session information for the user logged in.

Returns:

HttpSession object which contains only the userId and the session token

Throws:

java.lang.Exception - if a system error occurred while processing the request

Sample Request:

```
<soapenv:Envelope
```



```

    xmlns:soapenv="http://schemas.xmlsoap.org/soap/envelope/"
    xmlns:ws="http://ws.tririga.com">
<soapenv:Body>
  <ws:getHttpSession/>
</soapenv:Body>
</soapenv:Envelope>

```

Sample Response:

```

<soap:Envelope
  xmlns:soap="http://schemas.xmlsoap.org/soap/envelope/"
  xmlns:xsd="http://www.w3.org/2001/XMLSchema"
  xmlns:xsi="http://www.w3.org/2001/XMLSchema-instance">
  <soap:Body>
    <getHttpSessionResponse xmlns="http://ws.tririga.com">
      <out>
        <id xmlns="http://dto.ws.tririga.com">2534881</id>
        <token xmlns="http://dto.ws.tririga.com">1163456628218</token>
      </out>
    </getHttpSessionResponse>
  </soap:Body>
</soap:Envelope>

```

getListByTypes

Description:

Get the list types for the given object type ids passed in

Parameters:

objectTypeIds - Array objectTypes IDs to retrieve the lists of

Returns:

An array of ListType objects

Throws:

ObjectTypeDoesNotExistException - Thrown if the objectType does not exist. Also thrown if the user does not have access to the business object

InvalidArgumentException

java.lang.Exception - if a system error occurred while processing the request

Sample Request:

```

<soapenv:Envelope
  xmlns:soapenv="http://schemas.xmlsoap.org/soap/envelope/"
  xmlns:ws="http://ws.tririga.com">
  <soapenv:Body>
    <ws:getListByTypes>
      <ws:objectTypeIds>
        <!--Zero or more repetitions:-->
        <ws:long>106402</ws:long>
      </ws:objectTypeIds>
    </ws:getListByTypes>
  </soapenv:Body>
</soapenv:Envelope>

```

Sample Response: (Condensed)

```
<soap:Envelope
  xmlns:soap="http://schemas.xmlsoap.org/soap/envelope/"
  xmlns:xsd="http://www.w3.org/2001/XMLSchema"
  xmlns:xsi="http://www.w3.org/2001/XMLSchema-instance">
  <soap:Body>
    <getListByTypesResponse xmlns="http://ws.tririga.com">
      <out>
        <ns1:ListType xmlns:ns1="http://dto.ws.tririga.com">
          <dependantList xmlns="http://dto.ws.tririga.com">false</dependantList>
          <description xsi:nil="true" xmlns="http://dto.ws.tririga.com"/>
          <id xmlns="http://dto.ws.tririga.com">103053</id>
          <label xmlns="http://dto.ws.tririga.com">triPCardType</label>
          <language xmlns="http://dto.ws.tririga.com">English</language>
          <name xmlns="http://dto.ws.tririga.com">triPCardType</name>
          <parentId xmlns="http://dto.ws.tririga.com">0</parentId>
          <parentProduct xsi:nil="true" xmlns="http://dto.ws.tririga.com"/>
          <product xmlns="http://dto.ws.tririga.com">triPeople</product>
          <sourceClassId xmlns="http://dto.ws.tririga.com">0</sourceClassId>
          <sourceObjectTypeId xmlns="http://dto.ws.tririga.com">0</sourceObjectTypeId>
          <sourceType xmlns="http://dto.ws.tririga.com">0</sourceType>
          <system xmlns="http://dto.ws.tririga.com">false</system>
          <type xmlns="http://dto.ws.tririga.com">System</type>
        </ns1:ListType>
      </out>
    </getListByTypesResponse>
  </soap:Body>
</soap:Envelope>
```

getListItems

Description:

Get the possible list values for a given list ID

Parameters:

listId - the ID of the list to retrieve

Returns:

An array of ListItems

Throws:

ListDoesNotExistException - Thrown if the given list ID does not exist. Also thrown if the user does not have access to the module, or business object if applicable

InvalidArgumentException - Thrown if the ID is invalid

Sample Request:

```
<soapenv:Envelope
  xmlns:soapenv="http://schemas.xmlsoap.org/soap/envelope/"
  xmlns:ws="http://ws.tririga.com">
  <soapenv:Body>
    <ws:getListItems>
      <ws:listId>103053</ws:listId>
    </ws:getListItems>
  </soapenv:Body>
</soapenv:Envelope>
```

```
</soapenv:Body>
</soapenv:Envelope>
```

Sample Response:

```
<soap:Envelope
  xmlns:soap="http://schemas.xmlsoap.org/soap/envelope/"
  xmlns:xsd="http://www.w3.org/2001/XMLSchema"
  xmlns:xsi="http://www.w3.org/2001/XMLSchema-instance">
  <soap:Body>
    <getListItemsResponse xmlns="http://ws.tririga.com">
      <out>
        <ns1:ListItem xmlns:ns1="http://dto.ws.tririga.com">
          <id xmlns="http://dto.ws.tririga.com">2007995</id>
          <languageId xmlns="http://dto.ws.tririga.com">1</languageId>
          <sequenceNumber xmlns="http://dto.ws.tririga.com">0</sequenceNumber>
          <value xmlns="http://dto.ws.tririga.com">AMEX</value>
        </ns1:ListItem>
        <ns1:ListItem xmlns:ns1="http://dto.ws.tririga.com">
          <id xmlns="http://dto.ws.tririga.com">2007996</id>
          <languageId xmlns="http://dto.ws.tririga.com">1</languageId>
          <sequenceNumber xmlns="http://dto.ws.tririga.com">0</sequenceNumber>
          <value xmlns="http://dto.ws.tririga.com">Master Card</value>
        </ns1:ListItem>
        <ns1:ListItem xmlns:ns1="http://dto.ws.tririga.com">
          <id xmlns="http://dto.ws.tririga.com">2007997</id>
          <languageId xmlns="http://dto.ws.tririga.com">1</languageId>
          <sequenceNumber xmlns="http://dto.ws.tririga.com">0</sequenceNumber>
          <value xmlns="http://dto.ws.tririga.com">VISA</value>
        </ns1:ListItem>
      </out>
    </getListItemsResponse>
  </soap:Body>
</soap:Envelope>
```

getModuleId

Description:

Get the record ID for the module, given the module name

Parameters:

moduleName - name of the module needed

Returns:

The recordId for the module

Throws:

java.lang.Exception - if a system error occurred while processing the request
ModuleDoesNotExistException - Thrown if the given module does not exist
AccessException - Thrown if the user does not have access to the module

Sample Request:

```
<soapenv:Envelope
```

```

    xmlns:soapenv="http://schemas.xmlsoap.org/soap/envelope/"
    xmlns:ws="http://ws.tririga.com">
<soapenv:Body>
  <ws:getModuleId>
    <ws:moduleName>triPeople</ws:moduleName>
  </ws:getModuleId>
</soapenv:Body>
</soapenv:Envelope>

```

Sample Response:

```

<soap:Envelope
  xmlns:soap="http://schemas.xmlsoap.org/soap/envelope/"
  xmlns:xsd="http://www.w3.org/2001/XMLSchema"
  xmlns:xsi="http://www.w3.org/2001/XMLSchema-instance">
  <soap:Body>
    <getModuleIdResponse xmlns="http://ws.tririga.com">
      <out>7</out>
    </getModuleIdResponse>
  </soap:Body>
</soap:Envelope>

```

getModules

Description:

Get the name and ID of all modules known to the system

Returns:

An array of modules sorted by ID

Throws:

java.lang.Exception - If there was a system error processing the request

Sample Request:

```

<soapenv:Envelope
  xmlns:soapenv="http://schemas.xmlsoap.org/soap/envelope/"
  xmlns:ws="http://ws.tririga.com">
  <soapenv:Body>
    <ws:getModules/>
  </soapenv:Body>
</soapenv:Envelope>

```

Sample Response: (Condensed)

```

<soap:Envelope
  xmlns:soap="http://schemas.xmlsoap.org/soap/envelope/"
  xmlns:xsd="http://www.w3.org/2001/XMLSchema"
  xmlns:xsi="http://www.w3.org/2001/XMLSchema-instance">
  <soap:Body>
    <getModulesResponse xmlns="http://ws.tririga.com">
      <out>
        <ns1:Module xmlns:ns1="http://dto.ws.tririga.com">
          <id xmlns="http://dto.ws.tririga.com">25</id>
          <name xmlns="http://dto.ws.tririga.com">Classification</name>
        </ns1:Module>
      </out>
    </getModulesResponse>
  </soap:Body>
</soap:Envelope>

```

```

<ns1:Module xmlns:ns1="http://dto.ws.tririga.com">
  <id xmlns="http://dto.ws.tririga.com">20125</id>
  <name xmlns="http://dto.ws.tririga.com">Data Utilities</name>
</ns1:Module>
</out>
</getModulesResponse>
</soap:Body>
</soap:Envelope>

```

getNamedQueryType

Description:

Get the type of query for the given query. Can be used to determine whether to call runNamedMetricQuery or runNamedQuery.

Parameters:

moduleName - Used to help identify the query
objectTypeName - Used to help identify the query
queryName - Name of the query

Returns:

A string value that contains the report type

Throws:

ModuleDoesNotExistException Thrown if the given module does not exist
QueryDoesNotExistException Thrown if the given query does not exist
Exception if a system error occurred while processing the request
AccessException - Thrown if the user does not have access to the module, business object, or query

Sample Request:

```

<soap:Envelope
  xmlns:soap=http://www.xxx/soap-envelope
  xmlns:ws="http://ws.tririga.com">
  <soap:Header/>
  <soap:Body>
    <ws:getNamedQueryType>
      <!--Optional:-->
      <ws:moduleName>triMetricFact</ws:moduleName>
      <!--Optional:-->
      <ws:objectTypeName>triBuildingFact</ws:objectTypeName>
      <ws:queryName>triBuildingFact - Related Report - Building Summary (Building Fact
    )</ws:queryName>
    </ws:getNamedQueryType>
  </soap:Body>
</soap:Envelope>

```

Sample Response: (Condensed)

```

<soap:Envelope
  xmlns:soap="http://www.xxx/soap-envelope">
  <soap:Body>
    <ns1:getNamedQueryTypeResponse xmlns:ns1="http://ws.tririga.com">

```

```
<ns1:out>Metric</ns1:out>
</ns1:getNamedQueryTypeResponse>
</soap:Body>
</soap:Envelope>
```

getObjectType

Description:

Get the full object type definition for the given object type ID

Parameters:

objectTypeId - The object type ID for which the definition will be returned

Returns:

An ObjectType object

Throws:

ObjectTypeDoesNotExistException - If an object type with the given ID does not exist.

InvalidArgumentException - If an object type ID <= 0 is passed in

java.lang.Exception - If there was a system error processing the request

AccessException - Thrown if the user does not have access to the business object

Sample Request:

```
<soapenv:Envelope
  xmlns:soapenv="http://schemas.xmlsoap.org/soap/envelope/"
  xmlns:ws="http://ws.tririga.com">
  <soapenv:Body>
    <ws:getObjectType>
      <ws:objectTypeId>106402</ws:objectTypeId>
    </ws:getObjectType>
  </soapenv:Body>
</soapenv:Envelope>
```

Sample Response: (Condensed)

```
<soap:Envelope
  xmlns:soap="http://schemas.xmlsoap.org/soap/envelope/"
  xmlns:xsd="http://www.w3.org/2001/XMLSchema"
  xmlns:xsi="http://www.w3.org/2001/XMLSchema-instance">
  <soap:Body>
    <getObjectTypeResponse xmlns="http://ws.tririga.com">
      <out>
        <approvalHistory xmlns="http://dto.ws.tririga.com">false</approvalHistory>
        <auditAccess xmlns="http://dto.ws.tririga.com">false</auditAccess>
        <auditActions xmlns="http://dto.ws.tririga.com">true</auditActions>
        <auditDataChanges xmlns="http://dto.ws.tririga.com">false</auditDataChanges>
        <childBaseObjectTypes xsi:nil="true" xmlns="http://dto.ws.tririga.com"/>
        <children xmlns="http://dto.ws.tririga.com"/>
        <createdById xmlns="http://dto.ws.tririga.com">0</createdById>
        <description xmlns="http://dto.ws.tririga.com">People Base Business
Object</description>
        <displayName xmlns="http://dto.ws.tririga.com">People</displayName>
        <hasCalendar xmlns="http://dto.ws.tririga.com">true</hasCalendar>
        <id xmlns="http://dto.ws.tririga.com">106402</id>
```

```

<moduleId xmlns="http://dto.ws.tririga.com">7</moduleId>
<name xmlns="http://dto.ws.tririga.com">triPeople</name>
<requireExplanation xmlns="http://dto.ws.tririga.com">>false</requireExplanation>
<rootOfHierarchy xmlns="http://dto.ws.tririga.com">>false</rootOfHierarchy>
<sections xmlns="http://dto.ws.tririga.com">
  <Section>
    <fields>
      <Field>
        <associationString xsi:nil="true"/>
        <attributeSequence>-1</attributeSequence>
        <autoPopulate>>false</autoPopulate>
        <colSpan>1</colSpan>
        <columnSeq>0</columnSeq>
        <dataType xsi:nil="true"/>
        <defaultValue/>
        <dependent>>false</dependent>
        <displayValue xsi:nil="true"/>
        <editUOMList>>false</editUOMList>
        <endRow>1</endRow>
        <fieldId>0</fieldId>
        <financialToken xsi:nil="true"/>
        <formula xsi:nil="true"/>
        <fullPath>>false</fullPath>
        <generateOnCreate>>false</generateOnCreate>
        <guiFieldId>0</guiFieldId>
        <guiFieldName xsi:nil="true"/>
        <guiFieldType>0</guiFieldType>
        <guild>0</guild>
        <guiRootClassificationId>0</guiRootClassificationId>
        <guiRootClassificationName xsi:nil="true"/>
        <guiSectionId>0</guiSectionId>
        <guiSectionName xsi:nil="true"/>
        <guiTabId>0</guiTabId>
        <hierarchyObjectId>0</hierarchyObjectId>
        <label>Review Status</label>
        <listId>0</listId>
        <listModuleId>0</listModuleId>
        <liveLink>>false</liveLink>
        <locatorField>>false</locatorField>
        <locatorModuleId>0</locatorModuleId>
        <mobileField>>false</mobileField>
        <mobileFieldSeq>0</mobileFieldSeq>
        <name>Review Status</name>
        <precision>700</precision>
        <queryId>0</queryId>
        <queryName xsi:nil="true"/>
        <readOnly>>false</readOnly>
        <required>>false</required>
        <resultColumn>>false</resultColumn>
        <rollupSource>~</rollupSource>
        <rootClassification>~</rootClassification>
        <rootClassificationId>0</rootClassificationId>
        <sectionName>System Info</sectionName>
        <seq>98</seq>
        <specId>0</specId>

```

```

    <specTemplateId>106402</specTemplateId>
    <startRow>1</startRow>
    <subAttributeType>~</subAttributeType>
    <subCategoryId>1</subCategoryId>
    <sumThisField>>false</sumThisField>
    <type>Text</type>
    <unitOfMeasure/>
    <unitOfMeasureSourceAttribute>0</unitOfMeasureSourceAttribute>
    <unitOfMeasureType>0</unitOfMeasureType>
    <validation>~</validation>
    <value xsi:nil="true"/>
    <valueId>0</valueId>
  </Field>
</fields>
<guiSectionId>0</guiSectionId>
<guiSectionName xsi:nil="true"/>
<id>1</id>
<label>System Info</label>
<name>System Info</name>
<refModuleId>-1</refModuleId>
<refObjectTypeId>-1</refObjectTypeId>
<rows xsi:nil="true"/>
<sections xsi:nil="true"/>
<type>GUI Section</type>
<typeId>0</typeId>
</Section>
</sections>
<showSingleTab xmlns="http://dto.ws.tririga.com">>false</showSingleTab>
<type xmlns="http://dto.ws.tririga.com">0</type>
</out>
</getObjectTypeResponse>
</soap:Body>
</soap:Envelope>

```

getObjectTypeActions

Description:

Get the available actions for the given bold, guild and/or record ID

Parameters:

moduleId - The module ID

recordId - The record ID of the object whose current state actions options are available, use "-1" for the default available actions

objectTypeId - The objectTypeId to retrieve the actions from

guild - The GUI ID of the actions you want to retrieve, use "-1" to ignore

Returns:

An array of ObjectTypeAction objects

Throws:

InvalidArgumentException - Thrown if any of the arguments passed in are invalid. Also thrown if the user does not have access to the business object

java.lang.Exception - if a system error occurred while processing the request

Sample Request:

```

<soapenv:Envelope
  xmlns:soapenv="http://schemas.xmlsoap.org/soap/envelope/"
  xmlns:ws="http://ws.tririga.com">
  <soapenv:Body>
    <ws:getObjectTypeActions>
      <ws:moduleId>7</ws:moduleId>
      <ws:objectTypeId>106402</ws:objectTypeId>
      <ws:recordId>-1</ws:recordId>
      <ws:guild>10002361</ws:guild>
    </ws:getObjectTypeActions>
  </soapenv:Body>
</soapenv:Envelope>

```

Sample Response:

```

<soap:Envelope
  xmlns:soap="http://schemas.xmlsoap.org/soap/envelope/"
  xmlns:xsd="http://www.w3.org/2001/XMLSchema"
  xmlns:xsi="http://www.w3.org/2001/XMLSchema-instance">
  <soap:Body>
    <getObjectTypeActionsResponse xmlns="http://ws.tririga.com">
      <out>
        <boActionSteps xmlns="http://dto.ws.tririga.com">
          <ObjectTypeActionStep>
            <action>triCreateDraft</action>
            <actionId>0</actionId>
            <label>Create Draft</label>
            <objectTypeActionSteps>
              <ObjectTypeActionStep>
                <action>triCreateDraft</action>
                <actionId>58565</actionId>
                <label>Create Draft</label>
                <objectTypeActionSteps xsi:nil="true"/>
              </ObjectTypeActionStep>
            </objectTypeActionSteps>
          </ObjectTypeActionStep>
          <ObjectTypeActionStep>
            <action>triActivate</action>
            <actionId>0</actionId>
            <label>Activate</label>
            <objectTypeActionSteps>
              <ObjectTypeActionStep>
                <action>triActivate</action>
                <actionId>99023</actionId>
                <label>Activate</label>
                <objectTypeActionSteps xsi:nil="true"/>
              </ObjectTypeActionStep>
            </objectTypeActionSteps>
          </ObjectTypeActionStep>
        </boActionSteps>
        <guild xmlns="http://dto.ws.tririga.com">10002361</guild>
        <moduleId xmlns="http://dto.ws.tririga.com">7</moduleId>
        <objectTypeId xmlns="http://dto.ws.tririga.com">106402</objectTypeId>
        <recordId xmlns="http://dto.ws.tririga.com">-1</recordId>
      </out>
    </getObjectTypeActionsResponse>
  </soap:Body>
</soap:Envelope>

```

```
</getObjectTypeActionsResponse>
</soap:Body>
</soap:Envelope>
```

getObjectTypeByName

Description:

Get a full object type definition for the object with the name `objectName` in module `moduleName`

Parameters:

`moduleName` - The module name of the object

`objectName` - The object type name for which the definition will be returned

Returns:

An `ObjectType`

Throws:

`ObjectTypeDoesNotExistException` - Thrown if the given object type does not exist

`InvalidArgumentException` - Thrown if any of the arguments passed in are invalid Exception

`java.lang.Exception` - If there was a system error processing the request

`AccessException` - Thrown if the user does not have access to the business object

Sample Request:

```
<soapenv:Envelope
  xmlns:soapenv="http://schemas.xmlsoap.org/soap/envelope/"
  xmlns:ws="http://ws.tririga.com">
  <soapenv:Body>
    <ws:getObjectTypeByName>
      <ws:moduleName>triPeople</ws:moduleName>
      <ws:objectTypeName>triPeople</ws:objectTypeName>
    </ws:getObjectTypeByName>
  </soapenv:Body>
</soapenv:Envelope>
```

Sample Response: (Condensed)

```
<soap:Envelope
  xmlns:soap="http://schemas.xmlsoap.org/soap/envelope/"
  xmlns:xsd="http://www.w3.org/2001/XMLSchema"
  xmlns:xsi="http://www.w3.org/2001/XMLSchema-instance">
  <soap:Body>
    <getObjectTypeByNameResponse xmlns="http://ws.tririga.com">
      <out>
        <approvalHistory xmlns="http://dto.ws.tririga.com">false</approvalHistory>
        <auditAccess xmlns="http://dto.ws.tririga.com">false</auditAccess>
        <auditActions xmlns="http://dto.ws.tririga.com">true</auditActions>
        <auditDataChanges xmlns="http://dto.ws.tririga.com">false</auditDataChanges>
        <childBaseObjectTypes xsi:nil="true" xmlns="http://dto.ws.tririga.com"/>
        <children xmlns="http://dto.ws.tririga.com"/>
        <createdById xmlns="http://dto.ws.tririga.com">0</createdById>
        <description      xmlns="http://dto.ws.tririga.com">People      Base      Business
Object</description>
```

```

<displayName xmlns="http://dto.ws.tririga.com">People</displayName>
<hasCalendar xmlns="http://dto.ws.tririga.com">true</hasCalendar>
<id xmlns="http://dto.ws.tririga.com">106402</id>
<moduleId xmlns="http://dto.ws.tririga.com">7</moduleId>
<name xmlns="http://dto.ws.tririga.com">triPeople</name>
<requireExplanation xmlns="http://dto.ws.tririga.com">false</requireExplanation>
<rootOfHierarchy xmlns="http://dto.ws.tririga.com">false</rootOfHierarchy>
<sections xmlns="http://dto.ws.tririga.com">
  <Section>
    <fields>
      <Field>
        <associationString xsi:nil="true"/>
        <attributeSequence>-1</attributeSequence>
        <autoPopulate>false</autoPopulate>
        <colSpan>1</colSpan>
        <columnSeq>0</columnSeq>
        <dataType xsi:nil="true"/>
        <defaultValue/>
        <dependent>false</dependent>
        <displayValue xsi:nil="true"/>
        <editUOMList>false</editUOMList>
        <endRow>1</endRow>
        <fieldId>1014302</fieldId>
        <financialToken xsi:nil="true"/>
        <formula xsi:nil="true"/>
        <fullPath>false</fullPath>
        <generateOnCreate>false</generateOnCreate>
        <guiFieldId>0</guiFieldId>
        <guiFieldName xsi:nil="true"/>
        <guiFieldType>0</guiFieldType>
        <guild>0</guild>
        <guiRootClassificationId>0</guiRootClassificationId>
        <guiRootClassificationName xsi:nil="true"/>
        <guiSectionId>0</guiSectionId>
        <guiSectionName xsi:nil="true"/>
        <guiTabId>0</guiTabId>
        <hierarchyObjectId>0</hierarchyObjectId>
        <label>Company Name</label>
        <listId>-1</listId>
        <listModuleId>-1</listModuleId>
        <liveLink>false</liveLink>
        <locatorField>false</locatorField>
        <locatorModuleId>0</locatorModuleId>
        <mobileField>false</mobileField>
        <mobileFieldSeq>0</mobileFieldSeq>
        <name>triCompanyNameTX</name>
        <precision>700</precision>
        <queryId>0</queryId>
        <queryName xsi:nil="true"/>
        <readOnly>false</readOnly>
        <required>false</required>
        <resultColumn>false</resultColumn>
        <rollupSource>~</rollupSource>
        <rootClassification>~</rootClassification>
        <rootClassificationId>-1</rootClassificationId>

```

```

    <sectionName>Detail</sectionName>
    <seq>1363</seq>
    <specId>0</specId>
    <specTemplateId>106402</specTemplateId>
    <startRow>1</startRow>
    <subAttributeType>~</subAttributeType>
    <subCategoryId>12</subCategoryId>
    <sumThisField>false</sumThisField>
    <type>Text</type>
    <unitOfMeasure/>
    <unitOfMeasureSourceAttribute>-1</unitOfMeasureSourceAttribute>
    <unitOfMeasureType>-1</unitOfMeasureType>
    <validation>~</validation>
    <value xsi:nil="true"/>
    <valueId>0</valueId>
  </Field>
</fields>
<guiSectionId>0</guiSectionId>
<guiSectionName xsi:nil="true"/>
<id>12</id>
<label>Detail</label>
<name>Detail</name>
<refModuleId>-1</refModuleId>
<refObjectTypeId>-1</refObjectTypeId>
<rows xsi:nil="true"/>
<sections xsi:nil="true"/>
<type>GUI Section</type>
<typeId>0</typeId>
</Section>
</sections>
<showSingleTab xmlns="http://dto.ws.tririga.com">false</showSingleTab>
<type xmlns="http://dto.ws.tririga.com">0</type>
</out>
</getObjectTypeByNameResponse>
</soap:Body>
</soap:Envelope>

```

See the glossary for the usage and definitions of the getObjectType(long) object and its sub objects and how to use them properly.

getObjectTypeId

Description:

Get the record ID for the objectType, given the module name and the objectTypeName

Parameters:

moduleName - Name of the module

objectTypeName - Name of the objectType

Returns:

The recordId of the objectType

Throws:

ObjectTypeDoesNotExistException - Thrown if the given object type does not exist

InvalidArgumentException - Thrown if any of the arguments passed in are invalid Exception
java.lang.Exception - if a system error occurred while processing the request
AccessException - Thrown if the user does not have access to the business object

Sample Request:

```
<soapenv:Envelope
  xmlns:soapenv="http://schemas.xmlsoap.org/soap/envelope/"
  xmlns:ws="http://ws.tririga.com">
  <soapenv:Body>
    <ws:getObjectTypeId>
      <ws:moduleName>triPeople</ws:moduleName>
      <ws:objectTypeName>triPeople</ws:objectTypeName>
    </ws:getObjectTypeId>
  </soapenv:Body>
</soapenv:Envelope>
```

Sample Response:

```
<soap:Envelope
  xmlns:soap="http://schemas.xmlsoap.org/soap/envelope/"
  xmlns:xsd="http://www.w3.org/2001/XMLSchema"
  xmlns:xsi="http://www.w3.org/2001/XMLSchema-instance">
  <soap:Body>
    <getObjectTypeIdResponse xmlns="http://ws.tririga.com">
      <out>106402</out>
    </getObjectTypeIdResponse>
  </soap:Body>
</soap:Envelope>
```

getObjectTypeIdByModuleId

Description:

Get all the base object types for module with ID moduleId

Parameters:

moduleId - The module ID whose object types will be returned

isStandAlone - show Object Type List with objects that are stand alone

Returns:

An array of BaseObjectType objects, each of which contains the name and ID of an object type

Throws:

ModuleDoesNotExistException - If a module with the given ID does not exist

InvalidArgumentException - Thrown if any of the arguments passed in are invalid Exception

java.lang.Exception - If there was a system error processing the request

Sample Request:

```
<soapenv:Envelope
  xmlns:soapenv="http://schemas.xmlsoap.org/soap/envelope/"
  xmlns:ws="http://ws.tririga.com">
  <soapenv:Body>
    <ws:getObjectTypeListByModuleId>
      <ws:moduleId>7</ws:moduleId>
      <ws:isStandAlone>true</ws:isStandAlone>
    </ws:getObjectTypeListByModuleId>
  </soapenv:Body>
</soapenv:Envelope>
```

```
</ws:getObjectTypeListByModuleId>
</soapenv:Body>
</soapenv:Envelope>
```

Sample Response:

```
<soap:Envelope
  xmlns:soap="http://schemas.xmlsoap.org/soap/envelope/"
  xmlns:xsd="http://www.w3.org/2001/XMLSchema"
  xmlns:xsi="http://www.w3.org/2001/XMLSchema-instance">
  <soap:Body>
    <getObjectTypeListByModuleIdResponse xmlns="http://ws.tririga.com">
      <out>
        <ns1:BaseObjectType xmlns:ns1="http://dto.ws.tririga.com">
          <childBaseObjectTypes xsi:nil="true" xmlns="http://dto.ws.tririga.com"/>
          <id xmlns="http://dto.ws.tririga.com">106402</id>
          <name xmlns="http://dto.ws.tririga.com">triPeople</name>
        </ns1:BaseObjectType>
      </out>
    </getObjectTypeListByModuleIdResponse>
  </soap:Body>
</soap:Envelope>
```

See the glossary for the usage and definitions of the BaseObjectType object and its sub objects and how to use them properly.

getObjectTypeListByModuleName

Description:

Get all of the object type definitions for a specific module name

Parameters:

moduleName - The module name whose object types will be returned

isStandAlone - Show Object Type List with objects that are stand alone

Returns:

An array of BaseObjectType objects, each of which contains the name and ID of an object type

Throws:

ModuleDoesNotExistException - If a module with the given name does not exist

InvalidArgumentException - Thrown if any of the arguments passed in are invalid Exception

java.lang.Exception - If a system error occurred while processing the request

Sample Request:

```
<soapenv:Envelope
  xmlns:soapenv="http://schemas.xmlsoap.org/soap/envelope/"
  xmlns:ws="http://ws.tririga.com">
  <soapenv:Body>
    <ws:getObjectTypeListByModuleName>
      <ws:moduleName>triPeople</ws:moduleName>
      <ws:isStandAlone>true</ws:isStandAlone>
    </ws:getObjectTypeListByModuleName>
  </soapenv:Body>
```

```
</soapenv:Envelope>
```

Sample Response: see getObjectTypeListByModuleId

See the glossary for the usage and definitions of the TririgaWS#getObjectTypes(long, boolean) object and its sub objects and how to use them properly.

getProjectId

Description:

Get the record ID of the Project passed in, given that the user has access to that project

Parameters:

projectName - The name of the project you want the recordId for

Returns:

The Project recordId

Throws:

java.lang.Exception - If a system error occurred while processing the request
InvalidArgumentException - Thrown if projectName passed in is invalid

Sample Request:

```
<soapenv:Envelope
  xmlns:soapenv="http://schemas.xmlsoap.org/soap/envelope/"
  xmlns:ws="http://ws.tririga.com">
  <soapenv:Body>
    <ws:getProjectId>
      <ws:projectName>1000448 - TestProject</ws:projectName>
    </ws:getProjectId>
  </soapenv:Body>
</soapenv:Envelope>
```

Sample Response:

```
<soap:Envelope
  xmlns:soap="http://schemas.xmlsoap.org/soap/envelope/"
  xmlns:xsd="http://www.w3.org/2001/XMLSchema"
  xmlns:xsi="http://www.w3.org/2001/XMLSchema-instance">
  <soap:Body>
    <getProjectIdResponse xmlns="http://ws.tririga.com">
      <out>2530175</out>
    </getProjectIdResponse>
  </soap:Body>
</soap:Envelope>
```

getProjects

Description:

Get all of the projects that the user has access to

Returns:

An array of project records

Throws:

java.lang.Exception - If a system error occurred while processing the request

Sample Request:

```
<soapenv:Envelope
  xmlns:soapenv="http://schemas.xmlsoap.org/soap/envelope/"
  xmlns:ws="http://ws.tririga.com">
  <soapenv:Body>
    <ws:getProjects/>
  </soapenv:Body>
</soapenv:Envelope>
```

Sample Response:

```
<soap:Envelope
  xmlns:soap="http://schemas.xmlsoap.org/soap/envelope/"
  xmlns:xsd="http://www.w3.org/2001/XMLSchema"
  xmlns:xsi="http://www.w3.org/2001/XMLSchema-instance">
  <soap:Body>
    <getProjectsResponse xmlns="http://ws.tririga.com">
      <out>
        <ns1:Project xmlns:ns1="http://dto.ws.tririga.com">
          <id xmlns="http://dto.ws.tririga.com">2530175</id>
          <name xmlns="http://dto.ws.tririga.com">1000448 - TestProject</name>
        </ns1:Project>
        <ns1:Project xmlns:ns1="http://dto.ws.tririga.com">
          <id xmlns="http://dto.ws.tririga.com">2534255</id>
          <name xmlns="http://dto.ws.tririga.com">1000449 - Project DOS</name>
        </ns1:Project>
      </out>
    </getProjectsResponse>
  </soap:Body>
</soap:Envelope>
```

getRecordDataHeaders

Description:

Get raw header data for the given record ids

Parameters:

recordIds - ids of the records whose data we will retrieve

Returns:

All raw header data for the given record ids

Throws:

RecordDoesNotExistException - If the given record ID does not exist

InvalidArgumentException - If any of the record ids passed in are invalid

java.lang.Exception - If a system error occurred while processing the request

AccessException - Thrown if the user does not have access to the record

Sample Request:

```

<soapenv:Envelope
  xmlns:soapenv="http://schemas.xmlsoap.org/soap/envelope/"
  xmlns:ws="http://ws.tririga.com">
  <soapenv:Body>
    <ws:getRecordDataHeaders>
      <ws:recordIds>
        <!--Zero or more repetitions:-->
        <ws:long>2530175</ws:long>
      </ws:recordIds>
    </ws:getRecordDataHeaders>
  </soapenv:Body>
</soapenv:Envelope>

```

Sample Response:

```

<soap:Envelope
  xmlns:soap="http://schemas.xmlsoap.org/soap/envelope/"
  xmlns:xsd="http://www.w3.org/2001/XMLSchema"
  xmlns:xsi="http://www.w3.org/2001/XMLSchema-instance">
  <soap:Body>
    <getRecordDataHeadersResponse xmlns="http://ws.tririga.com">
      <out>
        <ns1:Record xmlns:ns1="http://dto.ws.tririga.com">
          <currentState xmlns="http://dto.ws.tririga.com">triActive</currentState>
          <description xsi:nil="true" xmlns="http://dto.ws.tririga.com"/>
          <guild xmlns="http://dto.ws.tririga.com">10006238</guild>
          <guiName xmlns="http://dto.ws.tririga.com">Capital Project</guiName>
          <id xmlns="http://dto.ws.tririga.com">2530175</id>
          <moduleId xmlns="http://dto.ws.tririga.com">19</moduleId>
          <name xmlns="http://dto.ws.tririga.com">1000448 - blah</name>
          <objectPath xmlns="http://dto.ws.tririga.com">\1000448 - TestProject</objectPath>
          <objectTypeId xmlns="http://dto.ws.tririga.com">10005241</objectTypeId>
          <objectTypeName
            xmlns="http://dto.ws.tririga.com">triCapitalProject</objectTypeName>
          <parentId xmlns="http://dto.ws.tririga.com">0</parentId>
          <sections xmlns="http://dto.ws.tririga.com"/>
          <tabs xsi:nil="true" xmlns="http://dto.ws.tririga.com"/>
        </ns1:Record>
      </out>
    </getRecordDataHeadersResponse>
  </soap:Body>
</soap:Envelope>

```

getRecordState

Description:

Method to retrieve the current state for each of the recordIds passed in.

Parameters:

Array of recordIds

Returns:

Array of State objects with the recordId and state

Throws:

InvalidArgumentException - Thrown if recordId is invalid

java.lang.Exception - if a system error occurred while processing the request

RecordDoesNotExistException - Thrown if the given record does not exist

AccessException - Thrown if the user does not have access to the record

Sample Request:

```
<soapenv:Envelope
  xmlns:soapenv="http://schemas.xmlsoap.org/soap/envelope/"
  xmlns:ws="http://ws.tririga.com">
  <soapenv:Body>
    <ws:getRecordState>
      <ws:recordIds>
        <!--Zero or more repetitions-->
        <ws:long>2530175</ws:long>
      </ws:recordIds>
    </ws:getRecordState>
  </soapenv:Body>
</soapenv:Envelope>
```

Sample Response:

```
<soap:Envelope
  xmlns:soap="http://schemas.xmlsoap.org/soap/envelope/"
  xmlns:xsd="http://www.w3.org/2001/XMLSchema"
  xmlns:xsi="http://www.w3.org/2001/XMLSchema-instance">
  <soap:Body>
    <getRecordStateResponse xmlns="http://ws.tririga.com">
      <out>
        <ns1:State xmlns:ns1="http://dto.ws.tririga.com">
          <recordId xmlns="http://dto.ws.tririga.com">2530175</recordId>
          <state xmlns="http://dto.ws.tririga.com">triActive</state>
          <trans xsi:nil="true" xmlns="http://dto.ws.tririga.com"/>
        </ns1:State>
      </out>
    </getRecordStateResponse>
  </soap:Body>
</soap:Envelope>
```

getRequiredGuiFieldNames

Description:

This gets the GUI field names that have the required and/or read-only attributes set to true.

This will facilitate validating against the same rules as those built into the application. Like the application, this will only check for base object fields on the first tab.

The ResponseHelperHeader returned will contain a ResponseHelper[] that will contain the [sectionName]::[fieldName] as the key and the value will be one of three values:

- 1 = Required
- 2 = Read Only
- 3 = Required, but in smart section

Parameters:

guild - The ID of the gui whose fields need to be retrieved

Returns:

A ResponseHelperHeader

Throws:

InvalidArgumentException - Thrown if any of the arguments passed in are invalid

java.lang.Exception - if a system error occurred while processing the request

AccessException - Thrown if the user does not have access to the form

Sample Request:

```
<soapenv:Envelope
  xmlns:soapenv="http://schemas.xmlsoap.org/soap/envelope/"
  xmlns:ws="http://ws.tririga.com">
  <soapenv:Body>
    <ws:getRequiredGuiFieldNames>
      <ws:guild>10002361</ws:guild>
    </ws:getRequiredGuiFieldNames>
  </soapenv:Body>
</soapenv:Envelope>
```

Sample Response:

```
<soap:Envelope
  xmlns:soap="http://schemas.xmlsoap.org/soap/envelope/"
  xmlns:xsd="http://www.w3.org/2001/XMLSchema"
  xmlns:xsi="http://www.w3.org/2001/XMLSchema-instance">
  <soap:Body>
    <getRequiredGuiFieldNamesResponse xmlns="http://ws.tririga.com">
      <out>
        <anyFailed xmlns="http://dto.ws.tririga.com">false</anyFailed>
        <failed xmlns="http://dto.ws.tririga.com">0</failed>
        <responseHelpers xmlns="http://dto.ws.tririga.com">
          <ResponseHelper>
            <key>Detail::triStatusCL</key>
            <name xsi:nil="true"/>
            <recordId>-1</recordId>
            <status xsi:nil="true"/>
            <value>2</value>
          </ResponseHelper>
          <ResponseHelper>
            <key>Detail::triUserMessageTX</key>
            <name xsi:nil="true"/>
            <recordId>-1</recordId>
            <status xsi:nil="true"/>
            <value>2</value>
          </ResponseHelper>
          <ResponseHelper>
            <key>Detail::triFirstNameTX</key>
            <name xsi:nil="true"/>
            <recordId>-1</recordId>
            <status xsi:nil="true"/>
            <value>1</value>
          </ResponseHelper>
          <ResponseHelper>
            <key>Detail::triNameTX</key>
            <name xsi:nil="true"/>
```

```

    <recordId>-1</recordId>
    <status xsi:nil="true"/>
    <value>2</value>
  </ResponseHelper>
  <ResponseHelper>
    <key>Detail::triProblemLocationTX</key>
    <name xsi:nil="true"/>
    <recordId>-1</recordId>
    <status xsi:nil="true"/>
    <value>2</value>
  </ResponseHelper>
  <ResponseHelper>
    <key>Detail::triLastNameTX</key>
    <name xsi:nil="true"/>
    <recordId>-1</recordId>
    <status xsi:nil="true"/>
    <value>1</value>
  </ResponseHelper>
</responseHelpers>
<successful xmlns="http://dto.ws.tririga.com">0</successful>
<total xmlns="http://dto.ws.tririga.com">0</total>
</out>
</getRequiredGuiFieldNamesResponse>
</soap:Body>
</soap:Envelope>

```

getRootRecordId

Description:

Get the root record ID for the given module

Parameters:

moduleName - Name of the module you want to search

objectTypeName - the objectType you want to search, leave as "" (empty String) for all objects

Returns:

A ResponseHelper which contains the name and the recordId of the root

Throws:

ModuleDoesNotExistException - Thrown if the given module does not exist

ObjectTypeDoesNotExistException - Thrown if the given object type does not exist

RecordDoesNotExistException - Thrown if the given record does not exist

InvalidArgumentException - Thrown if any of the arguments passed in are invalid Exception

java.lang.Exception - if a system error occurred while processing the request

AccessException - Thrown if the user does not have access to the module or business object

Sample Request:

```

<soapenv:Envelope
  xmlns:soapenv="http://schemas.xmlsoap.org/soap/envelope/"
  xmlns:ws="http://ws.tririga.com">
  <soapenv:Body>
    <ws:getRootRecordId>

```

```
<ws:moduleName>Location</ws:moduleName>
<ws:objectTypeName>triSpace</ws:objectTypeName>
</ws:getRootRecordId>
</soapenv:Body>
</soapenv:Envelope>
```

Sample Response:

```
<soap:Envelope
  xmlns:soap="http://schemas.xmlsoap.org/soap/envelope/"
  xmlns:xsd="http://www.w3.org/2001/XMLSchema"
  xmlns:xsi="http://www.w3.org/2001/XMLSchema-instance">
  <soap:Body>
    <getRootRecordIdResponse xmlns="http://ws.tririga.com">
      <out>
        <key xsi:nil="true" xmlns="http://dto.ws.tririga.com"/>
        <name xmlns="http://dto.ws.tririga.com"/>
        <recordId xmlns="http://dto.ws.tririga.com">-1</recordId>
        <status xsi:nil="true" xmlns="http://dto.ws.tririga.com"/>
        <value xmlns="http://dto.ws.tririga.com">10002873</value>
      </out>
    </getRootRecordIdResponse>
  </soap:Body>
</soap:Envelope>
```

getTargetRecords

Description:

Get the target records for a given objectType and section

Parameters:

objectTypeId - the object type id to get target records for
sectionName - name of the section to get target records for

Returns: associations of the target records

Throws:

ObjectTypeDoesNotExistException - Thrown if the given object type does not exist.
InvalidArgumentException - Thrown if any of the arguments passed in are invalid
Exception java.lang.Exception - if a system error occurred while processing the request
AccessException - Thrown if the user does not have access to the business object or target record

Sample Request:

```
<soapenv:Envelope
  xmlns:soapenv="http://schemas.xmlsoap.org/soap/envelope/"
  xmlns:ws="http://ws.tririga.com">
  <soapenv:Header/>
  <soapenv:Body>
    <ws:getTargetRecords>
      <ws:objectTypeId>106615</ws:objectTypeId>
      <ws:sectionName>History Log</ws:sectionName>
    </ws:getTargetRecords>
  </soapenv:Body>
</soapenv:Envelope>
```

```
</ws:getTargetRecords>
</soapenv:Body>
</soapenv:Envelope>
```

Sample Response:

```
<soap:Envelope
  xmlns:soap="http://schemas.xmlsoap.org/soap/envelope/"
  xmlns:xsd="http://www.w3.org/2001/XMLSchema"
  xmlns:xsi="http://www.w3.org/2001/XMLSchema-instance">
  <soap:Body>
    <getTargetRecordsResponse xmlns="http://ws.tririga.com">
      <out>
        <ns1:Association xmlns:ns1="http://dto.ws.tririga.com">
          <associatedModuleId xmlns="http://dto.ws.tririga.com">18</associatedModuleId>
          <associatedObjectTypeId
xmlns="http://dto.ws.tririga.com">106621</associatedObjectTypeId>
          <associatedRecordId
xmlns="http://dto.ws.tririga.com">10675383</associatedRecordId>
          <associatedRecordName
xmlns="http://dto.ws.tririga.com">Created</associatedRecordName>
          <associationName xmlns="http://dto.ws.tririga.com">Has</associationName>
          <inverseAssociationName
xmlns="http://dto.ws.tririga.com">Belongs
To</inverseAssociationName>
          <moduleName xmlns="http://dto.ws.tririga.com">System</moduleName>
          <objectTypeName xmlns="http://dto.ws.tririga.com">DM_History</objectTypeName>
          <recordId xmlns="http://dto.ws.tririga.com">0</recordId>
          <reverseAssociationName
xmlns="http://dto.ws.tririga.com">Belongs
To</reverseAssociationName>
          <sourceModuleId xmlns="http://dto.ws.tririga.com">11</sourceModuleId>
          <sourceObjectTypeId
xmlns="http://dto.ws.tririga.com">106615</sourceObjectTypeId>
        </ns1:Association>
      </out>
    </getTargetRecordsResponse>
  </soap:Body>
</soap:Envelope>
```

getUserLicenses

Description:

Get the licenses of the user making the request

Returns:

An array of ResponseHelper objects that have the license name and license ID as a name/value pair

Throws:

java.lang.Exception - if a system error occurred while processing the request
AccessException - Thrown if the user does not have access to License Manager

Sample Request:

```
<soapenv:Envelope
```

```

    xmlns:soapenv="http://schemas.xmlsoap.org/soap/envelope/"
    xmlns:ws="http://ws.tririga.com">
<soapenv:Body>
  <ws:getUserLicenses/>
</soapenv:Body>
</soapenv:Envelope>

```

Sample Response:

```

<soap:Envelope
  xmlns:soap="http://schemas.xmlsoap.org/soap/envelope/"
  xmlns:xsd="http://www.w3.org/2001/XMLSchema"
  xmlns:xsi="http://www.w3.org/2001/XMLSchema-instance">
  <soap:Body>
    <getUserLicensesResponse xmlns="http://ws.tririga.com">
      <out>
        <ns1:ResponseHelper xmlns:ns1="http://dto.ws.tririga.com">
          <key xsi:nil="true" xmlns="http://dto.ws.tririga.com"/>
          <name xmlns="http://dto.ws.tririga.com">IBM TRIRIGA Connector</name>
          <recordId xmlns="http://dto.ws.tririga.com">-1</recordId>
          <status xsi:nil="true" xmlns="http://dto.ws.tririga.com"/>
          <value xmlns="http://dto.ws.tririga.com">3021</value>
        </ns1:ResponseHelper>
        <ns1:ResponseHelper xmlns:ns1="http://dto.ws.tririga.com">
          <key xsi:nil="true" xmlns="http://dto.ws.tririga.com"/>
          <name xmlns="http://dto.ws.tririga.com">IBM TRIRIGA Application Platform</name>
          <recordId xmlns="http://dto.ws.tririga.com">-1</recordId>
          <status xsi:nil="true" xmlns="http://dto.ws.tririga.com"/>
          <value xmlns="http://dto.ws.tririga.com">3013</value>
        </ns1:ResponseHelper>
        <ns1:ResponseHelper xmlns:ns1="http://dto.ws.tririga.com">
          <key xsi:nil="true" xmlns="http://dto.ws.tririga.com"/>
          <name xmlns="http://dto.ws.tririga.com">IBM TRIRIGA Application Platform</name>
          <recordId xmlns="http://dto.ws.tririga.com">-1</recordId>
          <status xsi:nil="true" xmlns="http://dto.ws.tririga.com"/>
          <value xmlns="http://dto.ws.tririga.com">3017</value>
        </ns1:ResponseHelper>
      </out>
    </getUserLicensesResponse>
  </soap:Body>
</soap:Envelope>

```

putCurrencyConversionRates

Description:

This adds or updates conversion rates. If an added currency conversion rate overlaps a previously added rate, it will supersede the previously added rate. If the id for the Conversion rate is populated, the rate will be updated. If it is set to -1, it will create a new Conversion Rate.

Parameters:

rates - Array of conversion rates to save

Returns:

An array of the CurrencyConversionRate objects that were passed in; if the record was successfully created, the ID will be populated.

Throws:

InvalidArgumentException - If any of the conversion rates are invalid

java.lang.Exception - If a system error occurred while processing the request

AccessException - Thrown if the user does not have access to Currency Conversion Manager

Sample Request:

```
<soapenv:Envelope
  xmlns:soapenv="http://schemas.xmlsoap.org/soap/envelope/"
  xmlns:ws="http://ws.tririga.com" xmlns:dto="http://dto.ws.tririga.com">
  <soapenv:Body>
    <ws:putCurrencyConversionRates>
      <ws:CurrencyConversionRates>
        <!--Zero or more repetitions:-->
        <dto:CurrencyConversionRate>
          <dto:conversionGroup>Default</dto:conversionGroup>
          <dto:conversionRate>1.34</dto:conversionRate>
          <dto:endDate>2007-04-19T16:15:10-07:00</dto:endDate>
          <dto:frequencyGroup>Daily</dto:frequencyGroup>
          <dto:fromCurrency>Canada Dollars</dto:fromCurrency>
          <dto:id>-1</dto:id>
          <dto:startDate>2007-04-19T16:15:10-07:00</dto:startDate>
          <dto:toCurrency>US Dollars</dto:toCurrency>
        </dto:CurrencyConversionRate>
      </ws:CurrencyConversionRates>
    </ws:putCurrencyConversionRates>
  </soapenv:Body>
</soapenv:Envelope>
```

Sample Response:

```
<soap:Envelope
  xmlns:soap="http://schemas.xmlsoap.org/soap/envelope/"
  xmlns:xsd="http://www.w3.org/2001/XMLSchema"
  xmlns:xsi="http://www.w3.org/2001/XMLSchema-instance">
  <soap:Body>
    <putCurrencyConversionRatesResponse xmlns="http://ws.tririga.com">
      <out>
        <ns1:CurrencyConversionRate xmlns:ns1="http://dto.ws.tririga.com">
          <conversionGroup xmlns="http://dto.ws.tririga.com">Default</conversionGroup>
          <conversionRate xmlns="http://dto.ws.tririga.com">1.34</conversionRate>
          <endDate xmlns="http://dto.ws.tririga.com">2007-04-19T16:15:10-07:00</endDate>
          <frequencyGroup xmlns="http://dto.ws.tririga.com">Daily</frequencyGroup>
          <fromCurrency xmlns="http://dto.ws.tririga.com">Canada Dollars</fromCurrency>
          <id xmlns="http://dto.ws.tririga.com">4303</id>
          <startDate xmlns="http://dto.ws.tririga.com">2007-04-19T16:15:10-
07:00</startDate>
          <toCurrency xmlns="http://dto.ws.tririga.com">US Dollars</toCurrency>
        </ns1:CurrencyConversionRate>
      </out>
    </putCurrencyConversionRatesResponse>
  </soap:Body>
</soap:Envelope>
```

register

Description:

The register method is solely for use with a CustomBusinessConnectTask from the CustomTask object in workflow. It is used to register the IBM TRIRIGA Connector for Business Applications client with the active session user, to allow the actions executed from the custom code to be registered as part of the workflow process and not as an external process. If this method is called from outside the context of a calling from a workflow, it will have no effect on an external integration. See the *Application Building for the IBM TRIRIGA Application Platform* for more detailed information about how this method is to be used.

runDynamicQuery

Description:

Run a query using the given parameters.

Parameters:

projectName - Limit access to a particular project; if the value of this is "" (empty space), the query will search records in all projects that the session's user ID has access to

moduleName - Limit the query to records in this module, use "" (empty space) to indicate all modules

objectTypeNames - Limit the query to the given object types, use "" (empty space) to indicate all object types. If multiple object types are included, only fields that are part of the base object definition for that particular module will return data.

guiNames - Limit the query to the given GUIs, use "" (empty space) to indicate all GUIs

associatedModuleName - Module ID of associated records to be returned as part of the query

associatedObjectName - Object type ID of associated records to be returned as part of the query

projectScope - 0 for active project, 1 for Company Level, 2 for all projects

displayFields - Used to identify the fields (with their labels) that will be included in the report in the order in which they will appear. If a section name is not specified, or is not recognized, that section will be treated as the top-level section for the primary business object.

associatedDisplayFields - fields of the associated object. If a section name is not specified, or is not recognized, that section will be treated as the top-level section for the associated business object.

fieldSortOrders - Array of descriptors that describe how results should be ordered

filters - Array of dynamic filter parameters for this query

associationFilters - Array of dynamic filter parameters for associated records of this query

start - The number to start the search at. The start argument is base 1. Anything entered less than 1 resolves to 1.

maximumResultCount - Limits the number of records returned. The maximumResultCount argument cannot exceed the Max Integer Value of 2147483647, minus the start argument. Since the start argument is base 1, the maximumResultCount cannot exceed 2147483646.

Returns:

A QueryResult object containing the resulting records, a total count of the results and a continuation token, if any

Throws:

ProjectDoesNotExistException - Thrown if the given project does not exist

ModuleDoesNotExistException - Thrown if the given module does not exist

ObjectTypeDoesNotExistException - Thrown if the given object type does not exist

RecordDoesNotExistException - Thrown if the given record does not exist

InvalidArgumentException - Thrown if any of the arguments passed in are invalid
 Exception
 java.lang.Exception - If a system error occurred while processing the request
 AccessException - Thrown if the user does not have access to the module, business object, or record

Sample Request:

```
<soapenv:Envelope
  xmlns:soapenv="http://schemas.xmlsoap.org/soap/envelope/"
  xmlns:ws="http://ws.tririga.com" xmlns:dto="http://dto.ws.tririga.com">
  <soapenv:Body>
    <ws:runDynamicQuery>
      <ws:projectName/>
      <ws:moduleName>triPeople</ws:moduleName>
      <ws:objectTypeNames>
        <!--Zero or more repetitions:-->
        <ws:string>triPeople</ws:string>
      </ws:objectTypeNames>
      <ws:guiNames/>
      <ws:associatedModuleName/>
      <ws:associatedObjectName/>
      <ws:projectScope>2</ws:projectScope>
      <ws:displayFields>
        <!--Zero or more repetitions:-->
        <dto:DisplayLabel>
          <dto:fieldName>triFirstNameTX</dto:fieldName>
          <!--Optional:-->
          <dto:label>First Name</dto:label>
          <dto:sectionName>Detail</dto:sectionName>
        </dto:DisplayLabel>
      </ws:displayFields>
      <ws:associatedDisplayFields/>
      <ws:fieldSortOrders/>
      <ws:filters/>
      <ws:associationFilters/>
      <ws:start>1</ws:start>
      <ws:maximumResultCount>2</ws:maximumResultCount>
    </ws:runDynamicQuery>
  </soapenv:Body>
</soapenv:Envelope>
```

Sample Response:

```
<soap:Envelope
  xmlns:soap="http://schemas.xmlsoap.org/soap/envelope/"
  xmlns:xsd="http://www.w3.org/2001/XMLSchema"
  xmlns:xsi="http://www.w3.org/2001/XMLSchema-instance">
  <soap:Body>
    <runDynamicQueryResponse xmlns="http://ws.tririga.com">
      <out>
        <continuationToken xmlns="http://dto.ws.tririga.com">
          <tokenString>80240783D81B64C65DB4A49620432065-1163463554765-
0.2994752033211511</tokenString>
        </continuationToken>
        <queryResponseHelpers xmlns="http://dto.ws.tririga.com">
          <QueryResponseHelper>
            <assocBold xsi:nil="true"/>
          </QueryResponseHelper>
        </queryResponseHelpers>
      </out>
    </runDynamicQueryResponse>
  </soap:Body>
</soap:Envelope>
```

```

<assocId xsi:nil="true"/>
<bold>106402</bold>
<queryResponseColumns>
  <QueryResponseColumn>
    <displayValue>loadTest_0.06389105809334483</displayValue>
    <index>0</index>
    <label>First Name</label>
    <name>triFirstNameTX</name>
    <section>Detail</section>
    <uom/>
    <value>loadTest_0.06389105809334483</value>
  </QueryResponseColumn>
</queryResponseColumns>
<recordId>2573261</recordId>
</QueryResponseHelper>
<QueryResponseHelper>
  <assocBold xsi:nil="true"/>
  <assocId xsi:nil="true"/>
  <bold>106402</bold>
  <queryResponseColumns>
    <QueryResponseColumn>
      <displayValue>loadTest_0.019704049349783426</displayValue>
      <index>0</index>
      <label>First Name</label>
      <name>triFirstNameTX</name>
      <section>Detail</section>
      <uom/>
      <value>loadTest_0.019704049349783426</value>
    </QueryResponseColumn>
  </queryResponseColumns>
  <recordId>2573349</recordId>
</QueryResponseHelper>
</queryResponseHelpers>
<totalResults xmlns="http://dto.ws.tririga.com">450</totalResults>
</out>
</runDynamicQueryResponse>
</soap:Body>
</soap:Envelope>

```

runDynamicQueryContinue

Description:

Continue to run a query using the given parameters (see runDynamicQuery).



Note - The query runs each time runDynamicQueryContinue is executed. The results may not be as expected if the data is modified between executions of runDynamicQuery and runDynamicQueryContinue or runDynamicQueryContinue and runDynamicQueryContinue.

Parameters:

continuationToken - a continuation token for the next set of records included in the Query Result. It will return the same quantity of records from the previous call to runDynamicQuery. For example, if on the initial call to runDynamicQuery the start number is 1 and

maximumResultCount is 10, the next call using runDynamicQueryContinue returns 10 records starting from record 11.

Returns:

A QueryResult object containing the resulting records, a total count of the results and a new continuation token, if any.

Throws:

InvalidContinuationTokenException - If the continuation token is not recognized

java.lang.Exception - If a system error occurred while processing the request

AccessException - Thrown if the user does not have access to the record

Sample Request:

```
<soapenv:Envelope
  xmlns:soapenv="http://schemas.xmlsoap.org/soap/envelope/"
  xmlns:ws="http://ws.tririga.com" xmlns:dto="http://dto.ws.tririga.com">
  <soapenv:Body>
    <ws:runDynamicQueryContinue>
      <ws:continuationToken>
        <dto:tokenString>80240783D81B64C65DB4A49620432065-1163463554765-
0.2994752033211511</dto:tokenString>
      </ws:continuationToken>
    </ws:runDynamicQueryContinue>
  </soapenv:Body>
</soapenv:Envelope>
```

Sample Response:

```
<soap:Envelope
  xmlns:soap="http://schemas.xmlsoap.org/soap/envelope/"
  xmlns:xsd="http://www.w3.org/2001/XMLSchema"
  xmlns:xsi="http://www.w3.org/2001/XMLSchema-instance">
  <soap:Body>
    <runDynamicQueryContinueResponse xmlns="http://ws.tririga.com">
      <out>
        <continuationToken xmlns="http://dto.ws.tririga.com">
          <tokenString>E0C2BE7A7900E5AD37CA776BB5FF588B-1163463693640-
0.2012609069705198</tokenString>
        </continuationToken>
        <queryResponseHelpers xmlns="http://dto.ws.tririga.com">
          <QueryResponseHelper>
            <assocBold xsi:nil="true"/>
            <assocId xsi:nil="true"/>
            <bold>106402</bold>
            <queryResponseColumns>
              <QueryResponseColumn>
                <displayValue>api1test</displayValue>
                <index>0</index>
                <label>First Name</label>
                <name>triFirstNameTX</name>
                <section>Detail</section>
                <uom/>
                <value>api1test</value>
              </QueryResponseColumn>
            </queryResponseColumns>
            <recordId>2538355</recordId>
```

```

</QueryResponseHelper>
<QueryResponseHelper>
  <assocBold xsi:nil="true"/>
  <assocId xsi:nil="true"/>
  <bold>106402</bold>
  <queryResponseColumns>
    <QueryResponseColumn>
      <displayValue>Rodrigo</displayValue>
      <index>0</index>
      <label>First Name</label>
      <name>triFirstNameTX</name>
      <section>Detail</section>
      <uom/>
      <value>John</value>
    </QueryResponseColumn>
  </queryResponseColumns>
  <recordId>2528575</recordId>
</QueryResponseHelper>
</queryResponseHelpers>
<totalResults xmlns="http://dto.ws.tririga.com">450</totalResults>
</out>
</runDynamicQueryContinueResponse>
</soap:Body>
</soap:Envelope>

```

runNamedMetricQuery

Description:

Run a pre-defined metric query that is stored in the platform in the Report Manager.

Parameters:

moduleName - Used to help identify the query

objectTypeName - Used to help identify the query

queryName - Name of the query to execute

metricQueryfilters - Array of Filter objects for this query. The filters used do not need to be runtime filters pre-defined by this query. However, any filters already applied to the query will pertain.

groupBy - The Group By for this query.

start - The number to start the search at. The start argument is base 1. Anything entered less than 1 resolves to 1.

maximumResultCount - Limits the number of records returned. The maximumResultCount argument cannot exceed the Max Integer Value of 2147483647, minus the start argument. Since the start argument is base 1, the maximumResultCount cannot exceed 2147483646.

Returns:

A MetricQueryResult object containing the resulting records, a total count of the results and a continuation token, if any. Includes any secondary Group By records.

Throws:

ProjectDoesNotExistException - If the given project does not exist

ModuleDoesNotExistException - If the given module does not exist

ObjectTypeDoesNotExistException - If the given object type does not exist

RecordDoesNotExistException - If there are no records returned from the query

QueryDoesNotExistException - If the given query does not exist

InvalidArgumentException - If any of the arguments are invalid
Exception - If a general exception occurred while processing the request
AccessException - Thrown if the user does not have access to the module or business object

Sample Request:

```
<soap:Envelope
  xmlns:soap="http://www.xxx/soap-envelope/"
  xmlns:ws="http://ws.tririga.com" xmlns:dto="http://dto.ws.tririga.com">
  <soap:Header/>
  <soap:Body>
    <ws:runNamedMetricQuery>
      <!--Optional:-->
      <ws:moduleName>Location</ws:moduleName>
      <!--Optional:-->
      <ws:objectTypeName>triBuilding</ws:objectTypeName>
      <ws:queryName>Metric Report Parking</ws:queryName>
      <ws:metricQueryfilters>
        <!--Zero or more repetitions:-->
        <dto:MetricQueryFilter>
          <!--Optional:-->
          <dto:fieldName>triDimGeographyTX</dto:fieldName>
          <!--Optional:-->
          <dto:value>212968</dto:value>
        </dto:MetricQueryFilter>
      </ws:metricQueryfilters>
      <!--Optional:-->
      <ws:groupBy>
        <!--Optional:-->
        <dto:fieldName>triDimLocationTX</dto:fieldName>
      </ws:groupBy>
      <ws:start>1</ws:start>
      <ws:maximumResultCount>1</ws:maximumResultCount>
    </ws:runNamedMetricQuery>
  </soap:Body>
</soap:Envelope>
```

Sample Response:

```
<soap:Envelope xmlns:soap="http://www.xxx/soap-envelope/">
  <soap:Body>
    <ns1:runNamedMetricQueryResponse xmlns:ns1="http://ws.tririga.com">
      <ns1:out>
        <ns2:continuationToken xmlns:ns2="http://dto.ws.tririga.com">
          <ns2:tokenString>-67cb25bb:13cfe394cb5:-7fc9</ns2:tokenString>
        </ns2:continuationToken>
        <ns2:totalResults xmlns:ns2="http://dto.ws.tririga.com">2</ns2:totalResults>
        <ns2:metricQueryResponseHelpers xmlns:ns2="http://dto.ws.tririga.com">
          <ns2:MetricQueryResponseHelper>
            <ns2:bold>10002100</ns2:bold>
            <ns2:recordId>11991577</ns2:recordId>
            <ns2:metricQueryResponseColumns>
              <ns2:MetricQueryResponseColumn>
                <ns2:displayValue>77</ns2:displayValue>
                <ns2:index>0</ns2:index>
                <ns2:label>Parking Spaces (Open)</ns2:label>
                <ns2:name>triParkingOpenNU</ns2:name>
```

```

        <ns2:section xsi:nil="true" xmlns:xsi="http://www.xxx/XMLSchema-instance"/>
        <ns2:uom xsi:nil="true" xmlns:xsi="http://www.xxx/XMLSchema-instance"/>
        <ns2:value>77.00</ns2:value>
        <ns2:thresholdRangeColor>#96A634</ns2:thresholdRangeColor>

<ns2:thresholdRangeIconUrl>/images/threshold_High.gif</ns2:thresholdRangeIconUrl>
  </ns2:MetricQueryResponseColumn>
<ns2:MetricQueryResponseColumn>
  <ns2:displayValue>20</ns2:displayValue>
  <ns2:index>1</ns2:index>
  <ns2:label>Parking Spaces (Covered)</ns2:label>
  <ns2:name>triParkingCoveredNU</ns2:name>
  <ns2:section xsi:nil="true" xmlns:xsi="http://www.xxx/XMLSchema-instance"/>
  <ns2:uom xsi:nil="true" xmlns:xsi="http://www.xxx/XMLSchema-instance"/>
  <ns2:value>20.00</ns2:value>
  <ns2:thresholdRangeColor>#FFFF66</ns2:thresholdRangeColor>

<ns2:thresholdRangeIconUrl>/images/threshold_Caution.gif</ns2:thresholdRangeIconUrl>
  </ns2:MetricQueryResponseColumn>
</ns2:metricQueryResponseColumns>
<ns2:primaryGroupByDisplayValue>TMF Building
1</ns2:primaryGroupByDisplayValue>
  <ns2:primaryGroupByLabel>Location</ns2:primaryGroupByLabel>
  <ns2:primaryGroupByName>triDimLocationTX</ns2:primaryGroupByName>
  <ns2:primaryGroupByValue>TMF Building 1</ns2:primaryGroupByValue>
  <ns2:secondaryGroupByDisplayValue xsi:nil="true"
xmlns:xsi="http://www.xxx/XMLSchema-instance"/>
  <ns2:secondaryGroupByLabel xsi:nil="true"
xmlns:xsi="http://www.xxx/XMLSchema-instance"/>
  <ns2:secondaryGroupByName xsi:nil="true"
xmlns:xsi="http://www.xxx/XMLSchema-instance"/>
  <ns2:secondaryGroupByValue xsi:nil="true"
xmlns:xsi="http://www.xxx/XMLSchema-instance"/>
  </ns2:MetricQueryResponseHelper>
</ns2:metricQueryResponseHelpers>
</ns1:out>
</ns1:runNamedMetricQueryResponse>
</soap:Body>
</soap:Envelope>

```

runNamedMetricQueryContinue

Description:

Retrieve the next batch of records from a metric query where the result size is larger than the maximumResultCount specified in the original call (see runNamedMetricQuery)

Parameters:

continuationToken - a continuation token for the next set of records included in the Query Result. It will return the same number of records from the previous call to runNamedMetricQuery. So if the initial call to runNamedMetricQuery has a start number of 1 and maximumResultCount of 10, the next call using this method will return 10 records starting from record 11.

Returns:

A MetricQueryResult object

Throws:

Exception - If a general exception occurred while processing the request

AccessException - Thrown if the user does not have access to the business object

Sample Request:

```
<soap:Envelope
  xmlns:soap="http://www.xxx/soap-envelope/"
  xmlns:ws="http://ws.tririga.com" xmlns:dto="http://dto.ws.tririga.com">
  <soap:Header/>
  <soap:Body>
    <ws:runNamedMetricQueryContinue>
      <!--Optional-->
      <ws:continuationToken>
        <dto:tokenString>-67cb25bb:13cfe394cb5:-7fc9</dto:tokenString>
      </ws:continuationToken>
    </ws:runNamedMetricQueryContinue>
  </soap:Body>
</soap:Envelope>
```

Sample Response:

```
<soap:Envelope xmlns:soap="http://www.xxx/soap-envelope/">
  <soap:Body>
    <ns1:runNamedMetricQueryContinueResponse xmlns:ns1="http://ws.tririga.com">
      <ns1:out>
        <ns2:continuationToken xsi:nil="true" xmlns:ns2="http://dto.ws.tririga.com"
xmlns:xsi="http://www.w3.org/2001/XMLSchema-instance"/>
        <ns2:totalResults xmlns:ns2="http://dto.ws.tririga.com">2</ns2:totalResults>
        <ns2:metricQueryResponseHelpers xmlns:ns2="http://dto.ws.tririga.com">
          <ns2:MetricQueryResponseHelper>
            <ns2:bold>10002100</ns2:bold>
            <ns2:recordId>11991581</ns2:recordId>
            <ns2:metricQueryResponseColumns>
              <ns2:MetricQueryResponseColumn>
                <ns2:displayValue>55</ns2:displayValue>
                <ns2:index>0</ns2:index>
                <ns2:label>Parking Spaces (Open)</ns2:label>
                <ns2:name>triParkingOpenNU</ns2:name>
                <ns2:section xsi:nil="true" xmlns:xsi="http://www.xxx/XMLSchema-instance"/>
                <ns2:uom xsi:nil="true" xmlns:xsi="http://www.xxx/XMLSchema-instance"/>
                <ns2:value>55.00</ns2:value>
                <ns2:thresholdRangeColor>#96A634</ns2:thresholdRangeColor>
              </ns2:MetricQueryResponseColumn>
              <ns2:MetricQueryResponseColumn>
                <ns2:displayValue>50</ns2:displayValue>
                <ns2:index>1</ns2:index>
                <ns2:label>Parking Spaces (Covered)</ns2:label>
                <ns2:name>triParkingCoveredNU</ns2:name>
                <ns2:section xsi:nil="true" xmlns:xsi="http://www.xxx/XMLSchema-instance"/>
                <ns2:uom xsi:nil="true" xmlns:xsi="http://www.xxx/XMLSchema-instance"/>
                <ns2:value>50.00</ns2:value>
                <ns2:thresholdRangeColor>#96A634</ns2:thresholdRangeColor>
              </ns2:MetricQueryResponseColumn>
            </ns2:metricQueryResponseHelpers>
          </ns1:out>
        </ns1:runNamedMetricQueryContinueResponse>
      </ns1:out>
    </ns1:runNamedMetricQueryContinueResponse>
  </soap:Body>
</soap:Envelope>
```



```

<ns2:thresholdRangelconUrl>/images/threshold_High.gif</ns2:thresholdRangelconUrl>
  </ns2:MetricQueryResponseColumn>
</ns2:metricQueryResponseColumns>
  <ns2:primaryGroupByDisplayValue>TMF Building
2</ns2:primaryGroupByDisplayValue>
  <ns2:primaryGroupByLabel>Location</ns2:primaryGroupByLabel>
  <ns2:primaryGroupByName>triDimLocationTX</ns2:primaryGroupByName>
  <ns2:primaryGroupByValue>TMF Building 2</ns2:primaryGroupByValue>
  <ns2:secondaryGroupByDisplayValue xsi:nil="true"
xmlns:xsi="http://www.w3.org/2001/XMLSchema-instance"/>
  <ns2:secondaryGroupByLabel xsi:nil="true"
xmlns:xsi="http://www.w3.org/2001/XMLSchema-instance"/>
  <ns2:secondaryGroupByName xsi:nil="true"
xmlns:xsi="http://www.w3.org/2001/XMLSchema-instance"/>
  <ns2:secondaryGroupByValue xsi:nil="true"
xmlns:xsi="http://www.w3.org/2001/XMLSchema-instance"/>
  </ns2:MetricQueryResponseHelper>
</ns2:metricQueryResponseHelpers>
</ns1:out>
</ns1:runNamedMetricQueryContinueResponse>
</soap:Body>
</soap:Envelope>

```

runNamedQuery

Description:

Run a pre-defined query that is stored in the platform in the Report Manager.

Parameters:

projectName - Limit access to a particular project; if the value of this is "" (empty string) it will ignore project scope

moduleName - Used to help identify the query

objectTypeName - Used to help identify the query

queryName - Name of the query to execute

filters - Array of Filter objects for this query. The filters used do not need to be runtime filters pre-defined by this query. However, any filters already applied to the static query will pertain. If a \$\$RECORDID\$\$ Association Filter is predefined on the query, a single Associated Record Id can be included in the request, within the Array of Filter. To do this, specify \$\$RECORDID\$\$ as the field name and the Associated Record ID as the value.

start - The number to start the search at. The start argument is base 1. Anything entered less than 1 resolves to 1.

maximumResultCount - Limits the number of records returned. The maximumResultCount argument cannot exceed the Max Integer Value of 2147483647, minus the start argument. Since the start argument is base 1, the maximumResultCount cannot exceed 2147483646.

Returns:

A QueryResult object containing the resulting records, a total count of the results and a continuation token, if any

Throws:

ProjectDoesNotExistException - If the given project does not exist

ModuleDoesNotExistException - If the given module does not exist

ObjectTypeDoesNotExistException - If the given object type does not exist

QueryDoesNotExistException - If the given query does not exist
 InvalidArgumentException - If any of the arguments are invalid
 java.lang.Exception - If a system error occurred while processing the request
 AccessException - Thrown if the user does not have access to the module, business object, or record

Sample Request:

```
<soapenv:Envelope
  xmlns:soapenv="http://schemas.xmlsoap.org/soap/envelope/"
  xmlns:ws="http://ws.tririga.com" xmlns:dto="http://dto.ws.tririga.com">
  <soapenv:Body>
    <ws:runNamedQuery>
      <ws:projectName/>
      <ws:moduleName>triPeople</ws:moduleName>
      <ws:objectTypeName>triPeople</ws:objectTypeName>
      <ws:queryName>triEmployee - Find</ws:queryName>
      <ws:filters>
        <dto:Filter>
          <dto:fieldName>$$RECORDID$$</dto:fieldName>
          <dto:value>10596554</dto:value>
        </dto:Filter>
        <dto:Filter>
          <dto:dataType>320</dto:dataType>
          <dto:fieldName>triNameTX</dto:fieldName>
          <dto:operator>11</dto:operator>
          <dto:sectionName>Detail</dto:sectionName>
          <dto:value>Guest User</dto:value>
        </dto:Filter>
      </ws:filters>
      <ws:start>1</ws:start>
      <ws:maximumResultCount>2</ws:maximumResultCount>
    </ws:runNamedQuery>
  </soapenv:Body>
</soapenv:Envelope>
```

Sample Response:

```
<soap:Envelope
  xmlns:soap="http://schemas.xmlsoap.org/soap/envelope/"
  xmlns:xsd="http://www.w3.org/2001/XMLSchema"
  xmlns:xsi="http://www.w3.org/2001/XMLSchema-instance">
  <soap:Body>
    <runNamedQueryResponse xmlns="http://ws.tririga.com">
      <out>
        <continuationToken xmlns="http://dto.ws.tririga.com">
          <tokenString>B36189CC1AB8D7989B867AC33C218A63-1163464971156-
0.9400269990980881</tokenString>
        </continuationToken>
        <queryResponseHelpers xmlns="http://dto.ws.tririga.com">
          <QueryResponseHelper>
            <assocBold xsi:nil="true"/>
            <assocId xsi:nil="true"/>
            <bold>106402</bold>
            <queryResponseColumns>
              <QueryResponseColumn>
                <displayValue xsi:nil="true"/>
              </QueryResponseColumn>
            </queryResponseColumns>
          </QueryResponseHelper>
        </queryResponseHelpers>
      </out>
    </runNamedQueryResponse>
  </soap:Body>
</soap:Envelope>
```

```

<index>0</index>
<label>!</label>
<name>triUserMessageFlagTX</name>
<section>Detail</section>
<uom/>
<value xsi:nil="true"/>
</QueryResponseColumn>
<QueryResponseColumn>
  <displayValue>API User 111</displayValue>
  <index>1</index>
  <label>Name</label>
  <name>triNameTX</name>
  <section>Detail</section>
  <uom/>
  <value>API User 111</value>
</QueryResponseColumn>
<QueryResponseColumn>
  <displayValue xsi:nil="true"/>
  <index>2</index>
  <label>Title</label>
  <name>triTitleTX</name>
  <section>Detail</section>
  <uom/>
  <value xsi:nil="true"/>
</QueryResponseColumn>
<QueryResponseColumn>
  <displayValue xsi:nil="true"/>
  <index>3</index>
  <label>Primary Organization</label>
  <name>triPathTX</name>
  <section>triPrimaryOrganization</section>
  <uom/>
  <value xsi:nil="true"/>
</QueryResponseColumn>
<QueryResponseColumn>
  <displayValue xsi:nil="true"/>
  <index>4</index>
  <label>Work Phone</label>
  <name>triWorkPhoneTX</name>
  <section>Detail</section>
  <uom/>
  <value xsi:nil="true"/>
</QueryResponseColumn>
<QueryResponseColumn>
  <displayValue xsi:nil="true"/>
  <index>5</index>
  <label>Work Fax</label>
  <name>triWorkFaxTX</name>
  <section>Detail</section>
  <uom/>
  <value xsi:nil="true"/>
</QueryResponseColumn>
<QueryResponseColumn>
  <displayValue xsi:nil="true"/>
  <index>6</index>

```

```

    <label>eMail</label>
    <name>triEmailTX</name>
    <section>Detail</section>
    <uom/>
    <value xsi:nil="true"/>
  </QueryResponseColumn>
</queryResponseColumns>
<recordId>2552575</recordId>
</QueryResponseHelper>
<QueryResponseHelper>
  <assocBold xsi:nil="true"/>
  <assocId xsi:nil="true"/>
  <bold>106402</bold>
  <queryResponseColumns>
    <QueryResponseColumn>
      <displayValue xsi:nil="true"/>
      <index>0</index>
      <label>!</label>
      <name>triUserMessageFlagTX</name>
      <section>Detail</section>
      <uom/>
      <value xsi:nil="true"/>
    </QueryResponseColumn>
    <QueryResponseColumn>
      <displayValue>api1test api1test</displayValue>
      <index>1</index>
      <label>Name</label>
      <name>triNameTX</name>
      <section>Detail</section>
      <uom/>
      <value>api1test api1test</value>
    </QueryResponseColumn>
    <QueryResponseColumn>
      <displayValue xsi:nil="true"/>
      <index>2</index>
      <label>Title</label>
      <name>triTitleTX</name>
      <section>Detail</section>
      <uom/>
      <value xsi:nil="true"/>
    </QueryResponseColumn>
    <QueryResponseColumn>
      <displayValue xsi:nil="true"/>
      <index>3</index>
      <label>Primary Organization</label>
      <name>triPathTX</name>
      <section>triPrimaryOrganization</section>
      <uom/>
      <value xsi:nil="true"/>
    </QueryResponseColumn>
    <QueryResponseColumn>
      <displayValue xsi:nil="true"/>
      <index>4</index>
      <label>Work Phone</label>
      <name>triWorkPhoneTX</name>

```

```

        <section>Detail</section>
        <uom/>
        <value xsi:nil="true"/>
    </QueryResponseColumn>
    <QueryResponseColumn>
        <displayValue xsi:nil="true"/>
        <index>5</index>
        <label>Work Fax</label>
        <name>triWorkFaxTX</name>
        <section>Detail</section>
        <uom/>
        <value xsi:nil="true"/>
    </QueryResponseColumn>
    <QueryResponseColumn>
        <displayValue xsi:nil="true"/>
        <index>6</index>
        <label>eMail</label>
        <name>triEmailTX</name>
        <section>Detail</section>
        <uom/>
        <value xsi:nil="true"/>
    </QueryResponseColumn>
</queryResponseColumns>
<recordId>2538355</recordId>
</QueryResponseHelper>
</queryResponseHelpers>
<totalResults xmlns="http://dto.ws.tririga.com">326</totalResults>
</out>
</runNamedQueryResponse>
</soap:Body>
</soap:Envelope>

```

runNamedQueryContinue

Description:

Retrieve the next batch of records from a query where the result size is larger than the maximumResultCount specified in the original call (see runNamedQuery)

Parameters:

continuationToken - a continuation token for the next set of records included in the Query Result. It will return the same number of records from the previous call to runNamedQuery. So if the initial call to runNamedQuery has a start number of 1 and maximumResultCount of 10, the next call using this method will return 10 records starting from record 11.

Returns:

A QueryResult object

Throws:

InvalidContinuationTokenException - If the token passed in is no longer valid
 java.lang.Exception - If a system error occurred while processing the request
 AccessException - Thrown if the user does not have access to the record

Sample Request:

```

<soapenv:Envelope
  xmlns:soapenv="http://schemas.xmlsoap.org/soap/envelope/"
  xmlns:ws="http://ws.tririga.com" xmlns:dto="http://dto.ws.tririga.com">
  <soapenv:Body>
    <ws:runNamedQueryContinue>
      <ws:continuationToken>
        <dto:tokenString>B36189CC1AB8D7989B867AC33C218A63-1163464971156-
0.9400269990980881</dto:tokenString>
      </ws:continuationToken>
    </ws:runNamedQueryContinue>
  </soapenv:Body>
</soapenv:Envelope>

```

Sample Response:

```

<soap:Envelope
  xmlns:soap="http://schemas.xmlsoap.org/soap/envelope/"
  xmlns:xsd="http://www.w3.org/2001/XMLSchema"
  xmlns:xsi="http://www.w3.org/2001/XMLSchema-instance">
  <soap:Body>
    <runNamedQueryContinueResponse xmlns="http://ws.tririga.com">
      <out>
        <continuationToken xmlns="http://dto.ws.tririga.com">
          <tokenString>2060CF2A8A3665D92287BB7E70CF1409-1163465373593-
0.26769267883643155</tokenString>
        </continuationToken>
        <queryResponseHelpers xmlns="http://dto.ws.tririga.com">
          <QueryResponseHelper>
            <assocBold xsi:nil="true"/>
            <assocId xsi:nil="true"/>
            <bold>106402</bold>
            <queryResponseColumns>
              <QueryResponseColumn>
                <displayValue xsi:nil="true"/>
                <index>0</index>
                <label>!</label>
                <name>triUserMessageFlagTX</name>
                <section>Detail</section>
                <uom/>
                <value xsi:nil="true"/>
              </QueryResponseColumn>
              <QueryResponseColumn>
                <displayValue>loadTest_0.0064628602916891875
test0.7470361165925274</displayValue>
                <index>1</index>
                <label>Name</label>
                <name>triNameTX</name>
                <section>Detail</section>
                <uom/>
                <value>loadTest_0.0064628602916891875 test0.7470361165925274</value>
              </QueryResponseColumn>
              <QueryResponseColumn>
                <displayValue xsi:nil="true"/>
                <index>2</index>
                <label>Title</label>
                <name>triTitleTX</name>

```

```

    <section>Detail</section>
    <uom/>
    <value xsi:nil="true"/>
  </QueryResponseColumn>
  <QueryResponseColumn>
    <displayValue xsi:nil="true"/>
    <index>3</index>
    <label>Primary Organization</label>
    <name>triPathTX</name>
    <section>triPrimaryOrganization</section>
    <uom/>
    <value xsi:nil="true"/>
  </QueryResponseColumn>
  <QueryResponseColumn>
    <displayValue xsi:nil="true"/>
    <index>4</index>
    <label>Work Phone</label>
    <name>triWorkPhoneTX</name>
    <section>Detail</section>
    <uom/>
    <value xsi:nil="true"/>
  </QueryResponseColumn>
  <QueryResponseColumn>
    <displayValue xsi:nil="true"/>
    <index>5</index>
    <label>Work Fax</label>
    <name>triWorkFaxTX</name>
    <section>Detail</section>
    <uom/>
    <value xsi:nil="true"/>
  </QueryResponseColumn>
  <QueryResponseColumn>
    <displayValue xsi:nil="true"/>
    <index>6</index>
    <label>eMail</label>
    <name>triEmailTX</name>
    <section>Detail</section>
    <uom/>
    <value xsi:nil="true"/>
  </QueryResponseColumn>
</queryResponseColumns>
<recordId>2573197</recordId>
</QueryResponseHelper>
<QueryResponseHelper>
  <assocBold xsi:nil="true"/>
  <assocId xsi:nil="true"/>
  <bold>106402</bold>
  <queryResponseColumns>
    <QueryResponseColumn>
      <displayValue xsi:nil="true"/>
      <index>0</index>
      <label>!</label>
      <name>triUserMessageFlagTX</name>
      <section>Detail</section>
      <uom/>

```

```

        <value xsi:nil="true"/>
    </QueryResponseColumn>
    <QueryResponseColumn>
        <displayValue>loadTest_0.009496939604808352
test0.8267033659176324</displayValue>
        <index>1</index>
        <label>Name</label>
        <name>triNameTX</name>
        <section>Detail</section>
    </uom/>
    <value>loadTest_0.009496939604808352 test0.8267033659176324</value>
</QueryResponseColumn>
<QueryResponseColumn>
    <displayValue xsi:nil="true"/>
    <index>2</index>
    <label>Title</label>
    <name>triTitleTX</name>
    <section>Detail</section>
</uom/>
    <value xsi:nil="true"/>
</QueryResponseColumn>
<QueryResponseColumn>
    <displayValue xsi:nil="true"/>
    <index>3</index>
    <label>Primary Organization</label>
    <name>triPathTX</name>
    <section>triPrimaryOrganization</section>
</uom/>
    <value xsi:nil="true"/>
</QueryResponseColumn>
<QueryResponseColumn>
    <displayValue xsi:nil="true"/>
    <index>4</index>
    <label>Work Phone</label>
    <name>triWorkPhoneTX</name>
    <section>Detail</section>
</uom/>
    <value xsi:nil="true"/>
</QueryResponseColumn>
<QueryResponseColumn>
    <displayValue xsi:nil="true"/>
    <index>5</index>
    <label>Work Fax</label>
    <name>triWorkFaxTX</name>
    <section>Detail</section>
</uom/>
    <value xsi:nil="true"/>
</QueryResponseColumn>
<QueryResponseColumn>
    <displayValue xsi:nil="true"/>
    <index>6</index>
    <label>eMail</label>
    <name>triEmailTX</name>
    <section>Detail</section>
</uom/>

```



```

        <value xsi:nil="true"/>
        </QueryResponseColumn>
    </queryResponseColumns>
    <recordId>2573389</recordId>
    </QueryResponseHelper>
</queryResponseHelpers>
<totalResults xmlns="http://dto.ws.tririga.com">326</totalResults>
</out>
</runNamedQueryContinueResponse>
</soap:Body>
</soap:Envelope>

```

See the glossary for the usage and definitions of the `runNamedQuery(String, String, String, String, Filter[], int, int)` object and its sub objects and how to use them properly.

runNamedQueryMultiBo

Description:

Run a pre-defined query that is stored in the platform in the Report Manager. This method supports queries defined with multiple associated business objects.

Parameters:

`projectName` - Limit access to a particular project; if the value of this is "" (empty string) it will ignore project scope

`moduleName` - Used to help identify the query

`objectTypeName` - Used to help identify the query

`queryName` - Name of the query to execute

`filters` - Array of Filter objects for this query. The filters used do not need to be runtime filters pre-defined by this query. However, any filters already applied to the static query will pertain. If a `$$RECORDID$$` Association Filter is predefined on the query, a single Associated Record Id can be included in the request, within the Array of Filter. To do this, specify `$$RECORDID$$` as the field name and the Associated Record ID as the value.

`start` - The number to start the search at. The start argument is base 1. Anything entered less than 1 resolves to 1.

`maximumResultCount` - Limits the number of records returned. The `maximumResultCount` argument cannot exceed the Max Integer Value of 2147483647, minus the start argument. Since the start argument is base 1, the `maximumResultCount` cannot exceed 2147483646.

Returns:

A `QueryMultiBoResult` object containing the resulting records, a total count of the results, and a continuation token, if any. Each resulting record in the `QueryMultiBoResult` will contain `QueryMultiBoResponseColumn` elements. Each `QueryMultiBoResponseColumn` element will include the module name, the business object name, and resulting data for the corresponding query defined display column. Each `QueryMultiBoResponseColumn` also will contain a `multiBoFieldIndex` element. This element is used as an incremental index for a `QueryMultiBoResponseColumn` Field that has the same name, module, and business object as another `QueryMultiBoResponseColumn` Field. The first time a particular `QueryMultiBoResponseColumn` Field is used, the `multiBoFieldIndex` element will not have a value. The next time a `QueryMultiBoResponseColumn` Field is used that has the same name, module, and business object, the `multiBoFieldIndex` will contain a value equal to 1. The next instance of a `QueryMultiBoResponseColumn` Field with the same name, module, and business object, will contain a `multiBoFieldIndex` equal to 2, and so on.

Throws:

ProjectDoesNotExistException - If the given project does not exist
 ModuleDoesNotExistException - If the given module does not exist
 ObjectTypeDoesNotExistException - If the given object type does not exist
 QueryDoesNotExistException - If the given query does not exist
 InvalidArgumentException - If any of the arguments are invalid
 java.lang.Exception - If a system error occurred while processing the request
 AccessException - Thrown if the user does not have access to the module, business object, or record

Sample Request:

```

<soapenv:Envelope
  xmlns:soapenv="http://schemas.xmlsoap.org/soap/envelope/"
  xmlns:ws="http://ws.tririga.com" xmlns:dto="http://dto.ws.tririga.com">
  <soapenv:Header/>
  <soapenv:Body>
    <ws:runNamedQueryMultiBo>
      <ws:projectName></ws:projectName>
      <ws:moduleName>triProject</ws:moduleName>
      <ws:objectTypeName>triFacilitiesProject</ws:objectTypeName>
      <ws:queryName>triFacilitiesProject - Projects And Users Demo</ws:queryName>
      <ws:filters>
        <dto:Filter>
          <dto:fieldName>$$RECORDID$$</dto:fieldName>
          <dto:value>10596554</dto:value>
        </dto:Filter>
        <dto:Filter>
          <dto:dataType>320</dto:dataType>
          <dto:fieldName>triNameTX</dto:fieldName>
          <dto:operator>16</dto:operator>
          <dto:sectionName>RecordInformation</dto:sectionName>
          <dto:value>Facility</dto:value>
        </dto:Filter>
      </ws:filters>
      <ws:start>1</ws:start>
      <ws:maximumResultCount>2</ws:maximumResultCount>
    </ws:runNamedQueryMultiBo>
  </soapenv:Body>
</soapenv:Envelope>
  
```

Sample Response:

```

<soap:Envelope
  xmlns:soap="http://schemas.xmlsoap.org/soap/envelope/"
  xmlns:xsd="http://www.w3.org/2001/XMLSchema"
  xmlns:xsi="http://www.w3.org/2001/XMLSchema-instance">
  <soap:Body>
    <runNamedQueryMultiBoResponse xmlns="http://ws.tririga.com">
      <out>
        <continuationToken xmlns="http://dto.ws.tririga.com">
          <tokenString>B36189CC1AB8D7989B867AC33C218A63-1163464971156-
0.9400269990980882</tokenString>
        </continuationToken>
        <queryMultiBoResponseHelpers>
          <QueryMultiBoResponseHelper>
            <bold>10003240</bold>
          </QueryMultiBoResponseHelper>
        </queryMultiBoResponseColumns>
      </out>
    </runNamedQueryMultiBoResponse>
  </soap:Body>
</soap:Envelope>
  
```

```

<QueryMultiBoResponseColumn>
  <displayValue>Facility Project Test 1</displayValue>
  <index>0</index>
  <module>triProject</module>
  <bo>triFacilitiesProject</bo>
  <label>Name</label>
  <name>triNameTX</name>
  <multiBoFieldIndex/>
  <section>RecordInformation</section>
  <uom/>
  <value>Facility Project Test 1</value>
</QueryMultiBoResponseColumn>
<QueryMultiBoResponseColumn>
  <displayValue>Captital Project Test 1</displayValue>
  <index>1</index>
  <module>triProject</module>
  <bo>triCapitalProject</bo>
  <label>Name</label>
  <name>triNameTX</name>
  <multiBoFieldIndex/>
  <section>RecordInformation</section>
  <uom/>
  <value>Captital Project Test 1</value>
</QueryMultiBoResponseColumn>
<QueryMultiBoResponseColumn>
  <displayValue>Captital Project Test 2</displayValue>
  <index>2</index>
  <module>triProject</module>
  <bo>triCapitalProject</bo>
  <label>Name</label>
  <name>triNameTX</name>
  <multiBoFieldIndex>1</multiBoFieldIndex>
  <section> RecordInformation</section>
  <uom/>
  <value>Captital Project Test 2</value>
</QueryMultiBoResponseColumn>
<QueryMultiBoResponseColumn>
  <displayValue>John User</displayValue>
  <index>3</index>
  <module>triPeople</module>
  <bo>triPeople</bo>
  <label>Name</label>
  <name>triNameTX</name>
  <multiBoFieldIndex/>
  <section> Details</section>
  <uom/>
  <value>John User</value>
</QueryMultiBoResponseColumn>
</queryMultiBoResponseColumns>
<recordId>10598779</recordId>
</QueryMultiBoResponseHelper>
</queryMultiBoResponseHelpers>
<totalResults xmlns="http://dto.ws.tririga.com">1</totalResults>
</:return>
</:runNamedQueryMultiBoResponse>

```

```
</soap:Body>  
</soap:Envelope>
```

runNamedQueryMultiBoContinue

Description:

Retrieve the next batch of records from a query where the result size is larger than the maximumResultCount specified in the original call (see runNamedQueryMultiBo or runNamedQueryMultiBoLocalized).

Parameters:

continuationToken - a continuation token for the next set of records included in the Query Result. It will return the same number of records from the previous call to runNamedQueryMultiBo. So if on the initial call to runNamedQueryMultiBo has a start number of 1 and maximumResultCount of 10, the next call using this method will return 10 records starting from record 11.

Returns:

A QueryMultiBoResult object

Throws:

InvalidContinuationTokenException - If the token passed in is no longer valid
java.lang.Exception - If a system error occurred while processing the request
AccessException - Thrown if the user does not have access to the record

Sample Request:

```
<soapenv:Envelope  
  xmlns:soapenv="http://schemas.xmlsoap.org/soap/envelope/"  
  xmlns:ws="http://ws.tririga.com" xmlns:dto="http://dto.ws.tririga.com">  
  <soapenv:Body>  
    <ws:runNamedQueryMultiBoContinue >  
      <ws:continuationToken>  
        <dto:tokenString>B36189CC1AB8D7989B867AC33C218A63-1163464971156-  
0.9400269990980882</dto:tokenString>  
      </ws:continuationToken>  
    </ws:runNamedQueryMultiBoContinue>  
  </soapenv:Body>  
</soapenv:Envelope>
```

Sample Response:

```
<soap:Envelope  
  xmlns:soap="http://schemas.xmlsoap.org/soap/envelope/"  
  xmlns:xsd="http://www.w3.org/2001/XMLSchema"  
  xmlns:xsi="http://www.w3.org/2001/XMLSchema-instance">  
  <soap:Body>  
    <runNamedQueryMultiBoResponse xmlns="http://ws.tririga.com">  
      <out>  
        <continuationToken xmlns="http://dto.ws.tririga.com">  
          <tokenString>B36189CC1AB8D7989B867AC33C218A63-1163464971156-  
0.9400269990980890</tokenString>  
        </continuationToken>  
        <queryMultiBoResponseHelpers>  
          <QueryMultiBoResponseHelper>
```

```

<bold>10003240</bold>
<queryMultiBoResponseColumns>
  <QueryMultiBoResponseColumn>
    <displayValue>Facility Project Test 1</displayValue>
    <index>0</index>
    <module>triProject</module>
    <bo>triFacilitiesProject</bo>
    <label>Name</label>
    <name>triNameTX</name>
    <multiBoFieldIndex/>
    <section>RecordInformation</section>
    <uom/>
    <value>Facility Project Test 1</value>
  </QueryMultiBoResponseColumn>
  <QueryMultiBoResponseColumn>
    <displayValue>Captital Project Test 1</displayValue>
    <index>1</index>
    <module>triProject</module>
    <bo>triCapitalProject</bo>
    <label>Name</label>
    <name>triNameTX</name>
    <multiBoFieldIndex/>
    <section>RecordInformation</section>
    <uom/>
    <value>Captital Project Test 1</value>
  </QueryMultiBoResponseColumn>
  <QueryMultiBoResponseColumn>
    <displayValue>Captital Project Test 3</displayValue>
    <index>2</index>
    <module>triProject</module>
    <bo>triCapitalProject</bo>
    <label>Name</label>
    <name>triNameTX</name>
    <multiBoFieldIndex>1</multiBoFieldIndex>
    <section> RecordInformation</section>
    <uom/>
    <value>Captital Project Test 3</value>
  </QueryMultiBoResponseColumn>
  <QueryMultiBoResponseColumn>
    <displayValue>Steve User</displayValue>
    <index>3</index>
    <module>triPeople</module>
    <bo>triPeople</bo>
    <label>Name</label>
    <name>triNameTX</name>
    <multiBoFieldIndex/>
    <section> Details</section>
    <uom/>
    <value>Steve User</value>
  </QueryMultiBoResponseColumn>
</queryMultiBoResponseColumns>
<recordId>10598779</recordId>
</QueryMultiBoResponseHelper>
</queryMultiBoResponseHelpers>
<totalResults xmlns="http://dto.ws.tririga.com">1</totalResults>

```

```
</:return>
</:runNamedQueryMultiBoResponse>
</soap:Body>
</soap:Envelope>
```

See the glossary for the usage and definitions of the `runNamedQuery(String, String, String, String, Filter[], int, int)` object and its sub objects and how to use them properly.

runNamedQueryMultiBoLocalized

Description:

Run a pre-defined query that is stored in the platform in the Report Manager. This method supports queries defined with multiple associated business objects. The results contain translated data values based on the user's locale.

Parameters:

`projectName` - Limit access to a particular project; if the value of this is "" (empty string) it will ignore project scope

`moduleName` - Used to help identify the query

`objectTypeName` - Used to help identify the query

`queryName` - Name of the query to execute

`filters` - Array of Filter objects for this query. The filters used do not need to be runtime filters pre-defined by this query. However, any filters already applied to the static query will pertain. If a `$$RECORDID$$` Association Filter is predefined on the query, a single Associated Record Id can be included in the request, within the Array of Filter. To do this, specify `$$RECORDID$$` as the field name and the Associated Record ID as the value.

`start` - The number to start the search at. The start argument is base 1. Anything entered less than 1 resolves to 1.

`maximumResultCount` - Limits the number of records returned. The `maximumResultCount` argument cannot exceed the Max Integer Value of 2147483647, minus the start argument. Since the start argument is base 1, the `maximumResultCount` cannot exceed 2147483646.

Returns:

A `QueryMultiBoResult` object containing the resulting records, a total count of the results, and a continuation token, if any. Each resulting record in the `QueryMultiBoResult` will contain `QueryMultiBoResponseColumn` elements. Each `QueryMultiBoResponseColumn` element will include the module name, the business object name, and resulting data for the corresponding query defined display column. Each `QueryMultiBoResponseColumn` also will contain a `multiBoFieldIndex` element. This element is used as an incremental index for a `QueryMultiBoResponseColumn` Field that has the same name, module, and business object as another `QueryMultiBoResponseColumn` Field. The first time a particular `QueryMultiBoResponseColumn` Field is used, the `multiBoFieldIndex` element will not have a value. The next time a `QueryMultiBoResponseColumn` Field is used that has the same name, module, and business object, the `multiBoFieldIndex` will contain a value equal to 1. The next instance of a `QueryMultiBoResponseColumn` Field with the same name, module, and business object, will contain a `multiBoFieldIndex` equal to 2, and so on. The `displayValue` element within each `QueryMultiBoResponseColumn`, will contain the translated value based on the user's locale.

Throws:

`ProjectDoesNotExistException` - If the given project does not exist

`ModuleDoesNotExistException` - If the given module does not exist

`ObjectTypeDoesNotExistException` - If the given object type does not exist

`QueryDoesNotExistException` - If the given query does not exist

InvalidArgumentException - If any of the arguments are invalid
 java.lang.Exception - If a system error occurred while processing the request
 AccessException - Thrown if the user does not have access to the module, business object, or record

Sample Request:

```
<soapenv:Envelope
  xmlns:soapenv="http://schemas.xmlsoap.org/soap/envelope/"
  xmlns:ws="http://ws.tririga.com" xmlns:dto="http://dto.ws.tririga.com">
  <soapenv:Header/>
  <soapenv:Body>
    <ws:runNamedQueryMultiBoLocalized>
      <ws:projectName></ws:projectName>
      <ws:moduleName>triProject</ws:moduleName>
      <ws:objectTypeName>triFacilitiesProject</ws:objectTypeName>
      <ws:queryName>triFacilitiesProject - Projects And Users Demo</ws:queryName>
      <ws:filters>
        <dto:Filter>
          <dto:fieldName>$$RECORDID$$</dto:fieldName>
          <dto:value>10596554</dto:value>
        </dto:Filter>
        <dto:Filter>
          <dto:dataType>320</dto:dataType>
          <dto:fieldName>triNameTX</dto:fieldName>
          <dto:operator>16</dto:operator>
          <dto:sectionName>RecordInformation</dto:sectionName>
          <dto:value>Facility</dto:value>
        </dto:Filter>
      </ws:filters>
      <ws:start>1</ws:start>
      <ws:maximumResultCount>2</ws:maximumResultCount>
    </ws:runNamedQueryMultiBoLocalized>
  </soapenv:Body>
</soapenv:Envelope>
```

Sample Response:

```
<soap:Envelope
  xmlns:soap="http://schemas.xmlsoap.org/soap/envelope/"
  xmlns:xsd="http://www.w3.org/2001/XMLSchema"
  xmlns:xsi="http://www.w3.org/2001/XMLSchema-instance">
  <soap:Body>
    <runNamedQueryMultiBoLocalizedResponse xmlns="http://ws.tririga.com">
      <out>
        <continuationToken xmlns="http://dto.ws.tririga.com">
          <tokenString>B36189CC1AB8D7989B867AC33C218A63-1163464971156-
0.9400269990980882</tokenString>
        </continuationToken>
        <queryMultiBoResponseHelpers>
          <QueryMultiBoResponseHelper>
            <bold>10003240</bold>
            <queryMultiBoResponseColumns>
              <QueryMultiBoResponseColumn>
                <displayValue>Facility Project Test 1</displayValue>
                <index>0</index>
              </QueryMultiBoResponseColumn>
            </queryMultiBoResponseColumns>
          </QueryMultiBoResponseHelper>
        </out>
      </runNamedQueryMultiBoLocalizedResponse>
    </soap:Body>
  </soap:Envelope>
```

```

    <bo>triFacilitiesProject</bo>
    <label>Name</label>
    <name>triNameTX</name>
    <multiBoFieldIndex/>
    <section>RecordInformation</section>
    <uom/>
    <value>Facility Project Test 1</value>
  </QueryMultiBoResponseColumn>
  <QueryMultiBoResponseColumn>
    <displayValue>Captital Project Test 1</displayValue>
    <index>1</index>
    <module>triProject</module>
    <bo>triCapitalProject</bo>
    <label>Name</label>
    <name>triNameTX</name>
    <multiBoFieldIndex/>
    <section>RecordInformation</section>
    <uom/>
    <value>Captital Project Test 1</value>
  </QueryMultiBoResponseColumn>
  <QueryMultiBoResponseColumn>
    <displayValue>Captital Project Test 2</displayValue>
    <index>2</index>
    <module>triProject</module>
    <bo>triCapitalProject</bo>
    <label>Name</label>
    <name>triNameTX</name>
    <multiBoFieldIndex>1</multiBoFieldIndex>
    <section> RecordInformation</section>
    <uom/>
    <value>Captital Project Test 2</value>
  </QueryMultiBoResponseColumn>
  <QueryMultiBoResponseColumn>
    <displayValue>John User</displayValue>
    <index>3</index>
    <module>triPeople</module>
    <bo>triPeople</bo>
    <label>Name</label>
    <name>triNameTX</name>
    <multiBoFieldIndex/>
    <section> Details</section>
    <uom/>
    <value>John User</value>
  </QueryMultiBoResponseColumn>
</queryMultiBoResponseColumns>
<recordId>10598779</recordId>
</QueryMultiBoResponseHelper>
</queryMultiBoResponseHelpers>
<totalResults xmlns="http://dto.ws.tririga.com">1</totalResults>
</:return>
</:runNamedQueryMultiBoLocalizedResponse>
</soap:Body>
</soap:Envelope>

```

saveRecord

Description:

Save specified records into TRIRIGA. When submitting, there are some basic validation rules that are applied to make sure that the information being saved is consistent with what a user would experience.

Any record that is being saved must have a valid action. If the `actionName` is not callable from the record's current state, an `InvalidActionNameException` is thrown.

If an action has multiple sub-actions, only the first sub-action will be executed, where the first sub-action is determined by listing the sub-action labels alphabetically. Use actions that have at most one sub-action instead of multiple sub-actions.

If you are creating a record and a required field is not set, an exception will be thrown.

If you are trying to populate a field that is read only, an exception will be thrown.

Since the structure of the `IntegrationRecord` object relates to how the structure of the Object you are trying to save is built, there is some flexibility on how the `IntegrationRecord` is used. If the structure is not built to correlate to the intended business object, an exception will be thrown.

Because the `saveRecord` method can accept an array of `IntegrationRecord` objects as the parameter, any exceptions thrown for an invalid record are compiled and captured into the value node of the `ResponseHelper` object that corresponds to the particular record. The records that have a status of failed and list exceptions do not modify existing IBM TRIRIGA data.

See the glossary for the usage and definitions of the `IntegrationRecord` object and its sub objects and how to use them properly.

Parameters:

An array of `IntegrationRecord` objects

Returns:

A `ResponseHelperHeader` object containing submission header information as well as the array of `ResponseHelper` objects containing the results and record IDs of the records submitted; if any exceptions were thrown, the data will be included in the appropriate `ResponseHelper` object

Throws:

`ModuleDoesNotExistException` - Thrown if the given module does not exist

`ObjectTypeDoesNotExistException` - Thrown if the given object type does not exist

`RecordDoesNotExistException` - Thrown if the given record does not exist

`RequiredFieldException` - Thrown if required field is not set

`ReadOnlyException` - Thrown if attempt to populate a read only field

`IntegrationRecordException` - Thrown if `IntegrationRecord` structure does not correlate to the intended business object

`InvalidActionNameException` - Thrown if a given action name does not exist or otherwise cannot be called by this user

`InvalidArgumentException` - Thrown if any of the arguments passed in are invalid Exception

`java.lang.Exception` - if a system error occurred while processing the request

`AccessException` - Thrown if the user does not have access to modify the record

Sample Request:

```
<soapenv:Envelope xmlns:soapenv="http://schemas.xmlsoap.org/soap/envelope/"
  xmlns:ws="http://ws.tririga.com" xmlns:dto="http://dto.ws.tririga.com">
  <soapenv:Header />
  <soapenv:Body>
    <ws:saveRecord>
      <ws:IntegrationRecords>
        <dto:IntegrationRecord>
          <dto:actionName>Create Draft</dto:actionName>
          <!--Optional -->
          <dto:guild>10002361</dto:guild>
          <dto:id>-1</dto:id>
          <dto:moduleId>7</dto:moduleId>
          <dto:objectTypeId>106402</dto:objectTypeId>
          <dto:objectTypeName>triPeople</dto:objectTypeName>
          <dto:sections>
            <dto:IntegrationSection>
              <dto:fields>
                <dto:IntegrationField>
                  <dto:name>triLastNameTX</dto:name>
                  <dto:value>Tester</dto:value>
                </dto:IntegrationField>
                <dto:IntegrationField>
                  <dto:name>triFirstNameTX</dto:name>
                  <dto:value>John</dto:value>
                </dto:IntegrationField>
                <dto:IntegrationField>
                  <dto:name>triUserLanguageLI</dto:name>
                  <dto:value>Japanese</dto:value>
                </dto:IntegrationField>
              </dto:fields>
              <dto:name>Detail</dto:name>
            </dto:IntegrationSection>
            <!--reports to -->
            <dto:IntegrationSection>
              <!--Optional: -->
              <dto:name>triPeopleReportsTo</dto:name>
              <!--Optional: -->
              <dto:rows>
                <!--Zero or more repetitions: -->
                <dto:IntegrationRows>
                  <dto:action>Append</dto:action>
                  <!--Optional: -->
                  <dto:recordId>12776874</dto:recordId>
                  <!--Optional: -->
                  <dto:rowIndex>1</dto:rowIndex>
                </dto:IntegrationRows>
              </dto:rows>
              <!--Optional: -->
              <dto:type>FIND</dto:type>
            </dto:IntegrationSection>
            <!--groups details -->
            <dto:IntegrationSection>
              <!--Optional: -->
              <dto:name>triGroupsDetails</dto:name>
```

```

<!--Optional: -->
<dto:rows>
  <!--Zero or more repetitions: -->
  <dto:IntegrationRows>
    <dto:action>Append</dto:action>
    <dto:fields>
      <dto:IntegrationField>
        <dto:name>User Group</dto:name>
        <dto:value>Admin Group</dto:value>
      </dto:IntegrationField>
    </dto:fields>
    <dto:rowIndex>0</dto:rowIndex>
  </dto:IntegrationRows>
</dto:rows>
<!--Optional: -->
<dto:type>Add</dto:type>
</dto:IntegrationSection>
<!--license details -->
<dto:IntegrationSection>
  <!--Optional: -->
  <dto:name>triLicenceDetails</dto:name>
  <!--Optional: -->
  <dto:rows>
    <!--Zero or more repetitions: -->
    <dto:IntegrationRows>
      <dto:action>Append</dto:action>
      <dto:fields>
        <dto:IntegrationField>
          <dto:name>User Licence</dto:name>
          <dto:value>IBM TRIRIGA Application Builder
</dto:value>
        </dto:IntegrationField>
      </dto:fields>
      <dto:rowIndex>0</dto:rowIndex>
    </dto:IntegrationRows>
    <dto:IntegrationRows>
      <dto:action>Append</dto:action>
      <dto:fields>
        <dto:IntegrationField>
          <dto:name>User Licence</dto:name>
          <dto:value>IBM TRIRIGA Application
Platform</dto:value>
        </dto:IntegrationField>
      </dto:fields>
      <dto:rowIndex>1</dto:rowIndex>
    </dto:IntegrationRows>
  </dto:rows>
  <!--Optional: -->
  <dto:type>Add</dto:type>
</dto:IntegrationSection>
</dto:sections>
</dto:IntegrationRecord>
</ws:IntegrationRecords>
</ws:saveRecord>
</soapenv:Body>

```

```
</soapenv:Envelope>
```

Sample Response:

```
<soap:Envelope xmlns:soap="http://schemas.xmlsoap.org/soap/envelope/"
xmlns:xsd="http://www.w3.org/2001/XMLSchema"
xmlns:xsi="http://www.w3.org/2001/XMLSchema-instance">
  <soap:Body>
    <saveRecordResponse xmlns="http://ws.tririga.com">
      <ResponseHelperHeader>
        <anyFailed xmlns="http://dto.ws.tririga.com">false</anyFailed>
        <failed xmlns="http://dto.ws.tririga.com">0</failed>
        <responseHelpers xmlns="http://dto.ws.tririga.com">
          <ResponseHelper>
            <key>1379055081938_0.009121259756713518</key>
            <name>Tester, John</name>
            <recordId>13796793</recordId>
            <status>Successful</status>
            <value xsi:nil="true"/>
          </ResponseHelper>
        </responseHelpers>
        <successful xmlns="http://dto.ws.tririga.com">1</successful>
        <total xmlns="http://dto.ws.tririga.com">1</total>
      </ResponseHelperHeader>
    </saveRecordResponse>
  </soap:Body>
</soap:Envelope>
```

terminateSession

The terminateSession method is used to terminate a user session. It is not necessary or required to call this action. However, if the user is shared between an integration process and a real person, this method can be called when the integration process has completed so that when the real person logs in, they do not get the warning on the screen that the user is currently logged in. When executed, this method does not return any response.

Parameters:

id - A java long representing the recordId of the user you want to remove from the session pool.

Returns:

Returns a ResponseHelper object with the Status set. If the process was unsuccessful, the Value is populated with the reason for the failure.

Throws:

java.lang.Exception - If a system error occurred while processing the request
InvalidArgumentException - Thrown if id passed in is invalid

triggerActions

Trigger the given actions (state transition) on the records specified in the TriggerActions Array. If an action has multiple sub-actions, only the first sub-action will be executed, where the first sub-action is determined by listing the sub-action labels alphabetically. Use actions that have

at most one sub-action instead of multiple sub-actions. The triggerActions method validates against business object state transitions.

Parameters:

triggerActions - Array of TriggerActions objects which contain the recordId and the action name to trigger

Throws:

RecordDoesNotExistException - If the record does not exist

ActionDoesNotExistException - If the given action does not exist for this object type or the record is not in a state that allows this action

InvalidArgumentException - If the record ID or action name is invalid

java.lang.Exception - If a system error occurred while processing the request

AccessException - Thrown if the user does not have access to read the record

Sample Request:

```
<soapenv:Envelope
  xmlns:soapenv="http://schemas.xmlsoap.org/soap/envelope/"
  xmlns:ws="http://ws.tririga.com" xmlns:dto="http://dto.ws.tririga.com">
  <soapenv:Body>
    <ws:triggerActions>
      <ws:TriggerActions>
        <!--Zero or more repetitions:-->
        <dto:TriggerActions>
          <dto:actionName>triSave</dto:actionName>
          <dto:recordId>2528575</dto:recordId>
        </dto:TriggerActions>
      </ws:TriggerActions>
    </ws:triggerActions>
  </soapenv:Body>
</soapenv:Envelope>
```

Sample Response:

```
<soap:Envelope
  xmlns:soap="http://schemas.xmlsoap.org/soap/envelope/"
  xmlns:xsd="http://www.w3.org/2001/XMLSchema"
  xmlns:xsi="http://www.w3.org/2001/XMLSchema-instance">
  <soap:Body>
    <triggerActionsResponse xmlns="http://ws.tririga.com">
      <out>
        <anyFailed xmlns="http://dto.ws.tririga.com">false</anyFailed>
        <failed xmlns="http://dto.ws.tririga.com">0</failed>
        <responseHelpers xmlns="http://dto.ws.tririga.com">
          <ResponseHelper>
            <key>1163465792078_0.36783446356265104</key>
            <name>triSave</name>
            <recordId>2528575</recordId>
            <status xsi:nil="true">Successful</status>
            <value xsi:nil="true"/>
          </ResponseHelper>
        </responseHelpers>
        <successful xmlns="http://dto.ws.tririga.com">1</successful>
        <total xmlns="http://dto.ws.tririga.com">1</total>
      </out>
    </triggerActionsResponse>
```

```
</soap:Body>  
</soap:Envelope>
```

3. Content

The following operations are meant to be used exclusively to transfer content for fields and Document Manager objects of type Document. The Document object maintains its content as a Large Object Binary (LOB). The field types that play a part in storing content as a LOBs or use binary transfers are Binary, Note, and Image.

In all operations content cannot be created or updated without a valid relative Smart Object reference. The reference is appropriated by setting the recordId of the SmartObject that contains the content in the Content object.

The only operation to return content is the 'download' operation.

Content being uploaded to a Document object will not create a new revision of the Smart object record. It will overwrite the latest revision. Workflows and actions will not be called when uploading, deleting, copying, or downloading content. Revisions and Action calls are handled through the record and not the content.

getContentFieldsDefinition

Description:

This operation will return a ContentField definition that will show you the relevant metadata about a content field type that is part of the requested business object. This will only return information for Binary, Image, and Note field types. Document objects do not have a field name, they are simply part of the Document.

These values can help facilitate the fieldName attribute needed for some operations that take in a Content parameter.

Parameters:

moduleName - the name of the module

boName - the business object name within the module that you are requesting information for

Throws:

ModuleDoesNotExistException - If the module does not exist.

ObjectTypeDoesNotExistException - If the business object does not exist.

AccessException - If the user does not have read access to the module

ContentException - If there is an error with the stream or checksum

IOException - If there is a System error

Sample Request:

```
<soapenv:Envelope
  xmlns:soapenv="http://schemas.xmlsoap.org/soap/envelope/"
  xmlns:ws="http://ws.tririga.com">
  <soapenv:Header/>
  <soapenv:Body>
    <ws:getContentFieldsDefinition>
      <ws:moduleName>cstIntegration</ws:moduleName>
      <ws:boName>cstIntegration</ws:boName>
    </ws:getContentFieldsDefinition>
  </soapenv:Body>
</soapenv:Envelope>
```

Sample Response:

```
<soap:Envelope
  xmlns:soap="http://schemas.xmlsoap.org/soap/envelope/"
  xmlns:xsd="http://www.w3.org/2001/XMLSchema"
  xmlns:xsi="http://www.w3.org/2001/XMLSchema-instance">
  <soap:Body>
    <getContentFieldsDefinitionResponse xmlns="http://ws.tririga.com">
      <contentFields>
        <ns1:ContentField xmlns:ns1="http://content.dto.ws.tririga.com">
          <boName xmlns="http://content.dto.ws.tririga.com">cstIntegration</boName>
          <fieldLabel xmlns="http://content.dto.ws.tririga.com">Binary</fieldLabel>
          <fieldName xmlns="http://content.dto.ws.tririga.com">cstBinaryBI</fieldName>
          <fieldType xmlns="http://content.dto.ws.tririga.com">Binary</fieldType>
          <moduleName
xmlns="http://content.dto.ws.tririga.com">cstIntegration</moduleName>
        </ns1:ContentField>
        <ns1:ContentField xmlns:ns1="http://content.dto.ws.tririga.com">
          <boName xmlns="http://content.dto.ws.tririga.com">cstIntegration</boName>
          <fieldLabel xmlns="http://content.dto.ws.tririga.com">Image</fieldLabel>
          <fieldName xmlns="http://content.dto.ws.tririga.com">cstImageIM</fieldName>
          <fieldType xmlns="http://content.dto.ws.tririga.com">Image</fieldType>
          <moduleName
xmlns="http://content.dto.ws.tririga.com">cstIntegration</moduleName>
        </ns1:ContentField>
        <ns1:ContentField xmlns:ns1="http://content.dto.ws.tririga.com">
          <boName xmlns="http://content.dto.ws.tririga.com">cstIntegration</boName>
          <fieldLabel xmlns="http://content.dto.ws.tririga.com">Note</fieldLabel>
          <fieldName xmlns="http://content.dto.ws.tririga.com">cstNoteNO</fieldName>
          <fieldType xmlns="http://content.dto.ws.tririga.com">Note</fieldType>
          <moduleName
xmlns="http://content.dto.ws.tririga.com">cstIntegration</moduleName>
        </ns1:ContentField>
      </contentFields>
    </getContentFieldsDefinitionResponse>
  </soap:Body>
</soap:Envelope>
```

upload

Description:

This operation allows the user to upload content to an existing record. The types of content that can be uploaded can be applied to the field types of Binary, Image, or Note. As well as content for a Document object.

Parameters:

Content object is passed with the following attributes specified:

recordId - the record id that the content belongs to

content - the binary content to upload

fieldName - the name of the content field within the 'primary' section of the business object. This value should be omitted if the content belongs to a Document object.

fileName - will only be used for the response object if it is not a Document object. If the record is a Document object, the file name from the record will be used.

Throws:

InvalidContentException - If the recordId or content fields of the content object are not correct.

InvalidDocumentTypeException - If the record is uploading to a Document object and the record is not of type Document.

IOException - If there is a System error.

AccessException - Thrown if the user does not have access to write to the record

Sample Request:

```
<soapenv:Envelope
  xmlns:soapenv="http://schemas.xmlsoap.org/soap/envelope/"
  xmlns:ws="http://ws.tririga.com" xmlns:con="http://content.dto.ws.tririga.com">
  <soapenv:Header/>
  <soapenv:Body>
    <ws:upload>
      <ws:content>
        <con:content>cid:939230577570</con:content>
        <con:fieldName>cstImageIM</con:fieldName>
        <con:fileName>logo.png</con:fileName>
        <con:recordId>5370494</con:recordId>
      </ws:content>
    </ws:upload>
  </soapenv:Body>
</soapenv:Envelope>
```



Note - The <con:content> node has a reference to an actual file. The utility used to demonstrate the SOAP request does not show the actual file.

Sample Response:

```
<soap:Envelope
  xmlns:soap="http://schemas.xmlsoap.org/soap/envelope/"
  xmlns:xsd="http://www.w3.org/2001/XMLSchema"
  xmlns:xsi="http://www.w3.org/2001/XMLSchema-instance">
  <soap:Body>
    <uploadResponse xmlns="http://ws.tririga.com">
      <return>
        <checksum xmlns="http://content.dto.ws.tririga.com">2833211863</checksum>
        <content ns1:mimeType="image/x-png" xmlns="http://content.dto.ws.tririga.com"
  xmlns:ns1="http://www.w3.org/2004/11/xmlmime"/>
        <fieldName xmlns="http://content.dto.ws.tririga.com">cstImageIM</fieldName>
        <fileName xmlns="http://content.dto.ws.tririga.com">logo.png</fileName>
        <length xsi:nil="true" xmlns="http://content.dto.ws.tririga.com">9080</length>
        <message xmlns="http://content.dto.ws.tririga.com"></message>
        <mimeType xmlns="http://content.dto.ws.tririga.com">image/png</mimeType>
        <path xsi:nil="true" xmlns="http://content.dto.ws.tririga.com"/>
        <recordId xmlns="http://content.dto.ws.tririga.com">5370494</recordId>
        <status xmlns="http://content.dto.ws.tririga.com">Success</status>
        <updatedAt xmlns="http://content.dto.ws.tririga.com">04/13/2009 07:03:43
  PM</updatedAt>
      </return>
    </uploadResponse>
  </soap:Body>
```

```
</soap:Envelope>
```

download

Description:

This operation allows the user to download binary content from the requested content field or Document object type. The types of content that can be uploaded can be applied to the fields types of Binary, Image, or Note. As well as content for a Document object.

Parameters:

Content object is passed with the following attributes specified:

recordId - the record id that the content belongs to

fieldName - the name of the content field within the 'primary' section of the business object. This value should be omitted if the content belongs to a Document object.

fileName - (optional) will only be used for the response object if it is not a Document object. If the record is a Document object, the file name from the record will be used.

Throws:

InvalidContentException - If the recordId or content fields of the content object are not correct.

InvalidDocumentTypeException - If the record is attempting to download from a Document object and the record is not of type Document.

IOException - If there is a System error.

Sample Request:

```
<soapenv:Envelope
  xmlns:soapenv="http://schemas.xmlsoap.org/soap/envelope/"
  xmlns:ws="http://ws.tririga.com" xmlns:con="http://content.dto.ws.tririga.com">
  <soapenv:Header/>
  <soapenv:Body>
    <ws:download>
      <ws:content>
        <con:fieldName>cstImageIM</con:fieldName>
        <con:recordId>5370494</con:recordId>
      </ws:content>
    </ws:download>
  </soapenv:Body>
</soapenv:Envelope>
```

Sample Response:

```
<soap:Envelope
  xmlns:soap="http://schemas.xmlsoap.org/soap/envelope/"
  xmlns:xsd="http://www.w3.org/2001/XMLSchema"
  xmlns:xsi="http://www.w3.org/2001/XMLSchema-instance">
  <soap:Body>
    <downloadResponse xmlns="http://ws.tririga.com">
      <return>
        <checksum xmlns="http://content.dto.ws.tririga.com">1927753939</checksum>
        <content ns1:mimeType="image/png" xmlns="http://content.dto.ws.tririga.com"
  xmlns:ns1="http://www.w3.org/2004/11/xmlmime">
          <Include
href="cid:12396738471521607232892@http://www.w3.org/2001/XMLSchema"
xmlns="http://www.w3.org/2004/08/xop/include"/>
        </content>
      </return>
    </downloadResponse>
  </soap:Body>
</soap:Envelope>
```

```

    </content>
    <fieldName xmlns="http://content.dto.ws.tririga.com">cstImageM</fieldName>
    <fileName
xmlns="http://content.dto.ws.tririga.com">file1239394426042.png</fileName>
    <length xmlns="http://content.dto.ws.tririga.com">9175</length>
    <message xsi:nil="true" xmlns="http://content.dto.ws.tririga.com"/>
    <mimeType xmlns="http://content.dto.ws.tririga.com">image/png</mimeType>
    <path xsi:nil="true" xmlns="http://content.dto.ws.tririga.com"/>
    <recordId xmlns="http://content.dto.ws.tririga.com">5370494</recordId>
    <status xmlns="http://content.dto.ws.tririga.com">Success</status>
    <updatedAt      xmlns="http://content.dto.ws.tririga.com">04/13/2009    06:50:47
PM</updatedAt>
    </return>
  </downloadResponse>
</soap:Body>
</soap:Envelope>

```



Note - The <content> node in the above SOAP response has content attached as a binary, but the SOAP utility used to print the response cannot show that the image did in fact successfully download.

copy

Description:

The copy operation is strictly used for content associated to Document objects only. It will copy the content from one Document object to the other. All instance level security is adhered to. For example if you do not have permission to read or write to one of the records, an AccessException is thrown.

Parameters:

fromRecordId - the record Id of the Document object content that you want to copy

toRecordId - the record id of the Document object that you want to copy to

Throws:

InvalidDocumentTypeException - If the recordId is not that of a Document object

AccessException - Thrown if the user does not have access to read the source record or write to the destination record

NotFoundException - If either record cannot be found

RemoteException = System error

RecordDoesNotExistException = If the record does not exist

ContentException - If there is an error with the stream or checksum

Sample Request:

```

<soapenv:Envelope
  xmlns:soapenv="http://schemas.xmlsoap.org/soap/envelope/"
  xmlns:ws="http://ws.tririga.com">
  <soapenv:Header/>
  <soapenv:Body>
    <ws:copy>
      <ws:fromRecordId>292814</ws:fromRecordId>
    </ws:copy>
  </soapenv:Body>
</soapenv:Envelope>

```

```
<ws:toRecordId>1488269</ws:toRecordId>
</ws:copy>
</soapenv:Body>
</soapenv:Envelope>
```

Sample Response:

```
<soap:Envelope
  xmlns:soap="http://schemas.xmlsoap.org/soap/envelope/"
  xmlns:xsd="http://www.w3.org/2001/XMLSchema"
  xmlns:xsi="http://www.w3.org/2001/XMLSchema-instance">
  <soap:Body>
    <copy xmlns="http://ws.tririga.com">
      <response>Success</response>
    </copy>
  </soap:Body>
</soap:Envelope>
```

uploadFrom

Description:

The uploadFrom operation is only applicable to Document objects. It is in place to help with large loads of content. To avoid the overhead of transferring binary data over HTTP, the content to be uploaded is referenced by a full network path, including the file name in the 'path' parameter of each Content object.

This means that the location of the referenced files must be fully accessible from the application server.

Also, all instance level security applies to the content being uploaded to the Document object.

Since this operation takes in a Collection of objects, each request is broken up into threads that originate from the DataImportAgent thread setting. The DataImportAgent does not need to be on in order for this to work.

Parameters:

Collection of Content objects, each with the following attributes:

recordId - the recordId of the Document object this content is being uploaded to
path - the full network path, including the file name

Throws:

RecordDoesNotExistException - Thrown if the record does not exist

InvalidDocumentTypeException - If the record is uploading to a Document object and the record is not of type Document

PathNotFoundException - Thrown if the network path is not found

ContentException - If there is an error with the stream or checksum

IOException - If there is a System error

AccessException - Thrown if the user does not have access to write to the record

Sample Request:

```
<soapenv:Envelope
  xmlns:soapenv="http://schemas.xmlsoap.org/soap/envelope/"
  xmlns:ws="http://ws.tririga.com" xmlns:con="http://content.dto.ws.tririga.com">
  <soapenv:Header/>
```

```

<soapenv:Body>
  <ws:uploadFrom>
    <ws:contents>
      <con:Content>
        <con:content>cid:490195952411</con:content>
        <con:path>\\networkFolder\Book1.txt</con:path>
        <con:recordId>292814</con:recordId>
      </con:Content>
    </ws:contents>
  </ws:uploadFrom>
</soapenv:Body>
</soapenv:Envelope>

```

Sample Response:

```

<soap:Envelope
  xmlns:soap="http://schemas.xmlsoap.org/soap/envelope/"
  xmlns:xsd="http://www.w3.org/2001/XMLSchema"
  xmlns:xsi="http://www.w3.org/2001/XMLSchema-instance">
  <soap:Body>
    <uploadFromResponse xmlns="http://ws.tririga.com">
      <reponses>
        <ns1:Response xmlns:ns1="http://content.dto.ws.tririga.com">
          <checksum xmlns="http://content.dto.ws.tririga.com">1294328364</checksum>
          <content xsi:nil="true" xmlns="http://content.dto.ws.tririga.com"/>
          <fieldName xsi:nil="true" xmlns="http://content.dto.ws.tririga.com"/>
          <fileName                               xsi:nil="true"
xmlns="http://content.dto.ws.tririga.com">Book1.txt</fileName>
          <length xsi:nil="true" xmlns="http://content.dto.ws.tririga.com">9080</length>
          <message xmlns="http://content.dto.ws.tririga.com"/>
          <mimeType                               xsi:nil="true"
xmlns="http://content.dto.ws.tririga.com">text/plain</mimeType>
          <path xmlns="http://content.dto.ws.tririga.com">\\networkFolder\Book1.txt</path>
          <recordId xmlns="http://content.dto.ws.tririga.com">292814</recordId>
          <status xmlns="http://content.dto.ws.tririga.com">Success</status>
          <updatedAt   xmlns="http://content.dto.ws.tririga.com">04/15/2009   02:39:26
PM</updatedAt>
        </ns1:Response>
      </reponses>
    </uploadFromResponse>
  </soap:Body>
</soap:Envelope>

```

downloadTo

Description:

The downloadTo operation is only applicable to Document objects. It is in place to help with large content extractions. To avoid the overhead of transferring binary data of HTTP, the content is downloaded to the full network path including the file name in the 'path' parameter of each Content object.

This means that the location of the network path must be fully accessible from the application server.

Also, all instance level security applies to the content being downloaded from the Document object.

Since this operation takes in a Collection of objects, each request is broken up into threads that originate from the DataImportAgent thread setting. The DataImportAgent does not need to be on in order for this to work.

Parameters:

Collection of Content objects, each with the following attributes:
recordId - the recordId of the Document object this content is being download from
path - the full network path, including the file name

Throws:

RecordDoesNotExistException - Thrown if the record does not exist
InvalidDocumentTypeException - If the record is uploading to a Document object and the record is not of type Document
PathNotFoundException - Thrown if the network path is not found
ContentException - If there is an error with the stream or checksum
IOException - If there is a System error
AccessException - Thrown if the user does not have access to write to the record

Sample Request:

```
<soapenv:Envelope
  xmlns:soapenv="http://schemas.xmlsoap.org/soap/envelope/"
  xmlns:ws="http://ws.tririga.com" xmlns:con="http://content.dto.ws.tririga.com">
  <soapenv:Header/>
  <soapenv:Body>
    <ws:downloadTo>
      <ws:contents>
        <con:Content>
          <con:path>\\networkFolder\test.htm</con:path>
          <con:recordId>1329419</con:recordId>
        </con:Content>
      </ws:contents>
    </ws:downloadTo>
  </soapenv:Body>
</soapenv:Envelope>
```

Sample Response:

```
<soap:Envelope
  xmlns:soap="http://schemas.xmlsoap.org/soap/envelope/"
  xmlns:xsd="http://www.w3.org/2001/XMLSchema"
  xmlns:xsi="http://www.w3.org/2001/XMLSchema-instance">
  <soap:Body>
    <downloadToResponse xmlns="http://ws.tririga.com">
      <reponses>
        <ns1:Response xmlns:ns1="http://content.dto.ws.tririga.com">
          <checksum xmlns="http://content.dto.ws.tririga.com">1294225029</checksum>
          <content xsi:nil="true" xmlns="http://content.dto.ws.tririga.com"/>
          <fieldName xsi:nil="true" xmlns="http://content.dto.ws.tririga.com"/>
          <fileName xmlns="http://content.dto.ws.tririga.com">test.htm</fileName>
          <length xmlns="http://content.dto.ws.tririga.com">2205</length>
          <message xsi:nil="true" xmlns="http://content.dto.ws.tririga.com"/>
          <mimeType xmlns="http://content.dto.ws.tririga.com">text/html</mimeType>
        </ns1:Response>
      </reponses>
    </downloadToResponse>
  </soap:Body>
</soap:Envelope>
```

```

    <path xmlns="http://content.dto.ws.tririga.com">\\networkFolder\test.htm</path>
    <recordId xmlns="http://content.dto.ws.tririga.com">1329419</recordId>
    <status xmlns="http://content.dto.ws.tririga.com">Success</status>
    <updatedAt xmlns="http://content.dto.ws.tririga.com">04/14/2009 10:57:42
AM</updatedAt>
    </ns1:Response>
  </reponses>
</downloadToResponse>
</soap:Body>
</soap:Envelope>

```

delete

Description:

The delete operation is strictly used for content associated to Document objects only. It will delete the content from the specified Document object. All instance level security is adhered to. For example if you do not have permission to delete the record, an AccessException is returned.

Parameters:

Content object is passed with the following attributes specified
recordId - the Document object record id that the content belongs to

Throws:

InvalidContentException - If the recordId is invalid.
InvalidDocumentTypeException - If the record is not a Document object
IOException - If there is a System error
AccessException - Thrown if the user does not have access to write to the record

Sample Request:

```

<soapenv:Envelope
  xmlns:soapenv="http://schemas.xmlsoap.org/soap/envelope/"
  xmlns:ws="http://ws.tririga.com" xmlns:con="http://content.dto.ws.tririga.com">
  <soapenv:Header/>
  <soapenv:Body>
    <ws:delete>
      <ws:content>
        <con:recordId>292814</con:recordId>
      </ws:content>
    </ws:delete>
  </soapenv:Body>
</soapenv:Envelope>

```

Sample Response:

```

<soap:Envelope
  xmlns:soap="http://schemas.xmlsoap.org/soap/envelope/"
  xmlns:xsd="http://www.w3.org/2001/XMLSchema"
  xmlns:xsi="http://www.w3.org/2001/XMLSchema-instance">
  <soap:Body>
    <deleteResponse xmlns="http://ws.tririga.com">
      <content>
        <checksum xmlns="http://content.dto.ws.tririga.com">0</checksum>
        <content xsi:nil="true" xmlns="http://content.dto.ws.tririga.com"/>
      </content>
    </deleteResponse>
  </soap:Body>
</soap:Envelope>

```

```

    <fieldName xsi:nil="true" xmlns="http://content.dto.ws.tririga.com"/>
    <fileName xsi:nil="true" xmlns="http://content.dto.ws.tririga.com"/>
    <length xsi:nil="true" xmlns="http://content.dto.ws.tririga.com"/>
    <message xsi:nil="true" xmlns="http://content.dto.ws.tririga.com"/>
    <mimeType xsi:nil="true" xmlns="http://content.dto.ws.tririga.com"/>
    <path xsi:nil="true" xmlns="http://content.dto.ws.tririga.com"/>
    <recordId xmlns="http://content.dto.ws.tririga.com">292814</recordId>
    <status xmlns="http://content.dto.ws.tririga.com">Success</status>
    <updatedAt      xmlns="http://content.dto.ws.tririga.com">04/13/2009    07:15:26
PM</updatedAt>
  </content>
</deleteResponse>
</soap:Body>
</soap:Envelope>

```

getContentLength

Description:

This operation allows the user to determine the size of the content. It is applicable to four content types: image, note, binary and document object.

Parameters:

Content object is passed with the following attributes specified:

recordId - the recordId the content belongs to

fieldName - the name of the content field within the 'primary' section of the business object.

This value should be omitted if the content belongs to a Document object.

Throws:

InvalidContentException - If the recordId is invalid

IOException - System error

InvalidDocumentTypeException - If the fieldName is blank and the recordId does not belong to a Document object

AccessException - Thrown if the user does not have access to read the record

Sample Request:

```

<soapenv:Envelope
  xmlns:soapenv="http://schemas.xmlsoap.org/soap/envelope/"
  xmlns:ws="http://ws.tririga.com" xmlns:con="http://content.dto.ws.tririga.com">
  <soapenv:Header/>
  <soapenv:Body>
    <ws:getContentLength>
      <ws:content>
        <con:fieldName>cstImageIM</con:fieldName>
        <con:recordId>5370494</con:recordId>
      </ws:content>
    </ws:getContentLength>
  </soapenv:Body>
</soapenv:Envelope>

```

Sample Response:

```

<soap:Envelope

```



```

xmlns:soap="http://schemas.xmlsoap.org/soap/envelope/"
xmlns:xsd="http://www.w3.org/2001/XMLSchema"
xmlns:xsi="http://www.w3.org/2001/XMLSchema-instance">
<soap:Body>
  <getContentLengthResponse xmlns="http://ws.tririga.com">
    <length>9175</length>
  </getContentLengthResponse>
</soap:Body>
</soap:Envelope>

```

getChecksum

Description:

This operation can be used to verify the checksum of content already in TRIRIGA. It is applicable to four content types: image, note, binary and document object.

Parameters:

Content object is passed with the following attributes specified:

recordId - the record id that the content belongs to

fieldName - the name of the content field within the 'primary' section of the business object. This value should be omitted if the content belongs to a Document object.

Throws:

InvalidContentException - If the content parameter is not filled out correctly

IOException - If there is a System error

InvalidDocumentTypeException - If the fieldName in the content is empty and the recordId does not correspond to a Document object

AccessException - Thrown if the user does not have access to read the record

Sample Request:

```

<soapenv:Envelope
  xmlns:soapenv="http://schemas.xmlsoap.org/soap/envelope/"
  xmlns:ws="http://ws.tririga.com" xmlns:con="http://content.dto.ws.tririga.com">
  <soapenv:Header/>
  <soapenv:Body>
    <ws:getChecksum>
      <ws:content>
        <con:fieldName>cstImageIM</con:fieldName>
        <con:recordId>5370494</con:recordId>
      </ws:content>
    </ws:getChecksum>
  </soapenv:Body>
</soapenv:Envelope>

```

Sample Response:

```

<soap:Envelope
  xmlns:soap="http://schemas.xmlsoap.org/soap/envelope/"
  xmlns:xsd="http://www.w3.org/2001/XMLSchema"
  xmlns:xsi="http://www.w3.org/2001/XMLSchema-instance">
  <soap:Body>
    <getChecksumResponse xmlns="http://ws.tririga.com">
      <checksum>1927753939</checksum>
    </getChecksumResponse>

```

```
</soap:Body>  
</soap:Envelope>
```

4. Data Transfer Objects Glossary

The following items are definitions of the objects that are used, or returned, or both, for the particular method calls into the IBM TRIRIGA Connector for Business Applications.

ActionItem – submit/return

- long workflowId
- long taskId

Association – submit/return

- long recordId
- long associatedRecordId
- String associationName
- String reverseAssociationName

AssociationDefinition - return

- long sourceModuleId
- long associatedModuleId
- long associatedObjectType
- long sourceObjectType
- String associationName
- String inverseAssociationName
- String moduleName
- String objectTypeName

ApplicationInfo – return

- String tririgaBuildNumber
- String dbBuildNumber
- String apiVersion

AssociationRecord – return

- Array of Associations associations
- long recordId

AvailableAction – return

- long **recordId**
- String **currentState**
- Array of Transitions **transitions**

ConversionGroup – return

- long **ID**
- String **name**

Currency – return

- String **abbreviation**
- String **name**
- String **symbol**
- String **format**
- String **delimiter**
- String **decimal**

CurrencyConversionRate – submit/return

- String **conversionGroup** - required for submission
- String **fromCurrency** - required for submission
- String **toCurrency** - required for submission
- double **conversionRate** - required for submission
- Date **startDate** - required for submission - follows ISO-8601 date format (see <http://www.w3.org/TR/NOTE-datetime>)
- Date **endDate** - required for submission - follows ISO-8601 date format (see <http://www.w3.org/TR/NOTE-datetime>)
- String **frequencyGroup** - optional for submission - If not specified the value will default to "Daily".
- long **ID** - only required for update, otherwise, ID is returned upon creation

ChildRecord – return

- long **childCount**
- String **path**

GUI – return

- long childRecordId
- long id
- String label
- int moduleId
- String moduleName
- String name
- long objectTypeId
- String objectTypeName
- long popupId
- long recordId
- String recordName
- boolean saveOnPopup
- boolean singleTab
- String state
- Tab[] tabs
- String type

Tab - return

- long id
- String instruction
- String label
- String name
- String tabInformation
- boolean visible
- String url
- Section[] sections

Section – return

- Field[] fields
- long guiSectionId
- String guiSectionName
- long id
- String label
- String name

- boolean readOnly
- long refModuleId
- long refObjectTypeId
- GuiRow[] rows
- String type
- int typeId
- boolean visible

Field – return

- DataType dataType
- String displayValue
- long guiRootClassificationId
- String guiRootClassificationName
- long guiSectionId
- String guiSectionName
- String label
- long listId
- long listModuleId
- boolean liveLink
- long locatorField
- long locatorModuleId
- boolean mobileField
- long mobileFieldSeq
- String name
- boolean readOnly
- long refObjectTypeId
- long refSpecId
- boolean required
- String rootClassification
- Long rootClassificationId
- String sectionName
- long specId
- String type
- String unitOfMeasure
- long unitOfMeasureType
- String value

HierarchyObjectType - return

- boolean **rootOfHierarchy**
- HierarchyObjectType[] **children**

IntegrationRecord - submit

- int **moduleId** - Required for submission
- long **objectTypeId** - Required for submission
- String **objectTypeName** - Required for submission
- long **guild** - Required to save particular GUI. If left as -1, the default GUI for the ObjectType specified will be used
- long **ID** - Required for update. If left as -1, the record will be created
- long **parentId** - ParentId or ObjectPath is required for hierarchies in order to save this object in the correct path
- long **projectId** - required to save /update the record in context a project. If set to 1, will be set to company level
- String **name** - optional to identify the record by the published name
- String **objectPath** - ParentId or ObjectPath is required for hierarchies in order to save this object in the correct path
- String **actionName** - required action to take on the record. Must be a valid action for the record's current state. If no action is passed and the record is not new, the record by default will save the data being passed in if a valid save action exists for the record's current state and if the action is present on the form. Also, you can pass a comma-delimited String of sequential actions to take if the object is not transitioned to a new state.

To facilitate loading historical data, you can bypass transitions by adding the word “bypass” to the desired state. For example, to place a newly loaded record into a retired state, set **actionName** to “bypass triRetired”. This feature bypasses any transition checks but enforces that the state does actually exist for the record at some point in its state tree. Only use this feature to load historical data; it should not be used as a general-purpose utility. Note that the value passed is a state (a final destination), not a transition.

- String **key** - optional to identify this record in the ResponseHelperHeader that is returned. If not set, a unique number is assigned
- IntegrationSection[] **sections** - Required to set at least one section object

IntegrationSection – submit

- String **type** - Optional, default is “DEFAULT”; can also be “ADD” or “FIND”. “ADD” sections are also known as embedded sections. A “FIND” section is known as a smart section.
- String **name** - Required, the data section name of the section
- IntegrationField[] **fields** - If section type is “DEFAULT”, there must be at least one IntegrationField set
- IntegrationRows[] **rows** - If section type is “ADD” or “FIND”, there must be at least one IntegrationRow set

The following example shows section type = “ADD”:

```
<dto:IntegrationSection>
  <dto:name>triGroupsDetails</dto:name>
  <dto:rows>
    <dto:IntegrationRows>
      <dto:action>Append</dto:action>
      <dto:fields>
        <dto:IntegrationField>
          <dto:name>User Group</dto:name>
          <dto:value>Admin Group</dto:value>
        </dto:IntegrationField>
      </dto:fields>
    </dto:IntegrationRows>
  </dto:rows>
  <dto:type>Add</dto:type>
</dto:IntegrationSection>
```

The following example shows section type = “FIND”:

```
<dto:IntegrationSection>
  <dto:name>triManagedBy</dto:name>
  <dto:rows>
    <dto:IntegrationRows>
      <dto:action>Append</dto:action>
      <dto:recordId>12345</dto:recordId>
      <dto:rowIndex>0</dto:rowIndex>
    </dto:IntegrationRows>
  </dto:rows>
  <dto:type>Find</dto:type>
</dto:IntegrationSection>
```

IntegrationRows – submit

- int **rowIndex** - Optional, to keep track of the order of your rows
- long **recordId** - If the section type is set to “FIND”, this is required to know which record to associate. Not needed if section type is set to “ADD”
- String **action** - Optional, by default is set to “APPEND”, meaning it will append the record. Can also set it to “DELETE”, which will remove the record
- **IntegrationField[] fields** - Only required if section type is set to “ADD”. Not needed if section type set to “FIND”

The following example shows populating a single-record smart section:

```
</dto:IntegrationSection>
<!--reports to -->
<dto:IntegrationSection>
  <!--Optional: -->
  <dto:name>triPeopleReportsTo</dto:name>
  <!--Optional: -->
  <dto:rows>
    <!--Zero or more repetitions: -->
    <dto:IntegrationRows>
```



```
<dto:action>Append</dto:action>
<!--Optional: -->
<dto:recordId>12776874</dto:recordId>
<!--Optional: -->
  dto:rowIndex>1</dto:rowIndex>
</dto:IntegrationRows>
</dto:rows>
<!--Optional: -->
  <dto:type>FIND</dto:type>
</dto:IntegrationSection>
```

IntegrationField – submit

- String **name** - required. The name of the field
- String **value** - The value of the field. If left blank, will blank out the field

Module - return

- long **ID**
- String **name**

ListType - return

- long **id**
- boolean **system**
- String **language**
- String **product**
- String **type**
- String **name**
- String **description**
- String **label**
- int **sourceType**
- long **sourceClassId**
- long **sourceObjectTypeId**
- boolean **dependentList**
- String **parentProduct**
- long **parentId**

ListItem – return

- long **ID**
- String **value**

- long `languageId`
- long `sequenceNumber`

ObjectType – return

- int `moduleId`
- String `displayName`
- String `description`
- int `type`
- boolean `hasCalendar`
- boolean `auditActions`
- boolean `auditAccess`
- boolean `auditDataChanges`
- boolean `requireExplanation`
- boolean `showSingleTab`
- boolean `approvalHistory`
- long `createdById`
- Section[] `sections`

ObjectTypeAction - return

- long `moduleId`
- long `objectTypeId`
- long `guild`
- long `recordId`
- ObjectTypeActionStep[] `boActionSteps`

ObjectTypeActionStep - return

- String `action`
- String `label`
- long `actionId`
- ObjectTypeActionStep[] `objectTypeActionSteps`

BaseObjectType – return

- long `ID`
- String `name`

ResponseHelperHeader - return

- boolean **isAnyFailed** - Returns a value of 'true' if any of the records in the request have failed. Returns 'false' if none have failed.
- int **total** - The total number of record results returned by the request.
- int **failed** - The number of records that returned a failed response.
- int **successful** - The number of records that returned a successful response.
- ResponseHelper[] **responseHelpers** - An array of responseHelpers containing the result of each record returned in the request (see [ResponseHelper - return](#) below).

ResponseHelper – return

- Object **name** - Returns the publish name of the record result from the request.
- Object **value** - Commonly used to display errors returned from a failed request. In some contexts (for example, `getRootRecordId`), 'value' can also contain data pertinent to the request. If there are no errors and no data being returned with given request type, the value will be null.
- Object **key** - The key specified in the request that corresponds to this record result.
- Long **recordId** - The record id of this result.
- String **status** - The status of the request for this record result. Possible values are "Successful" and "Error".

Project - return

- long **ID**
- String **name**

Record – return

- int **moduleId**
- long **objectTypeId**
- String **objectTypeName**
- long **guild**
- String **guiName**
- long **ID**
- long **parentId**
- String **description**
- String **name**
- String **currentState**
- String **objectPath**

QueryResult - return

- ContinuationToken continuationToken
- int totalResults
- QueryResponseHelper[] queryResponseHelpers

QueryResponseHelper - return

- String recordId
- String bold
- String assocId
- String assocBold
- QueryResponseColumn[] queryResponseColumns

QueryResponseColumn - return

- int index
- String name
- String label
- String section
- String value
- String uom
- String displayValue

ContinuationToken - return

- String tokenString

DisplayLabel – submit

- String **sectionName** - Required name of the section
- String **fieldname** - Required name of the field
- String **label** - Optional label you want to give the column to identify in the results

FieldSortOrder - submit

- String **sectionName** - Required name of the section
- String **fieldname** - Required name of the field
- String **fieldLabel** - Optional label you want to give the column to identify the results
- int **dataType** - Required to determine the sort order; A value interpreted as a String will sort differently than a Number; if using java client, Static Constants are in the Filter class.

Options are:

- String - 320
- Number - 310
- Date -330
- DateTime - 335

Filter - submit

- String **sectionName** - Required name of the section
- String **fieldname** - Required name of the field
- int **operator** - Required to know what this filter is supposed to do. Constants are in this file. Options are:
 - After = 21
 - Before = 20
 - Contains = 16
 - Contains - Case Sensitive = 32
 - Does Not Contain = 35
 - Does Not Contain - Case Sensitive = 34
 - End With = 31
 - End With - Case Sensitive = 18
 - Equals = 10
 - In = 22
 - Less Than = 12
 - Less Than or Equals = 13
 - More Than = 14
 - More Than or Equals = 15
 - Not Equals = 11
 - Not In = 23
 - Start With = 30
 - Start With - Case Sensitive = 17
- int **dataType** - Required to determine how the operator type functions; if using java client, Static Constants are in this class. Options are:
 - String - 320
 - Number - 310
 - Date -330
 - DateTime - 335
- String **value** - Required; this is the value you want to filter against

AssociationFilter - submit

- String **associationName** - Required name of the association you want to filter against
- int **moduleId** - Required ID of the module of the associated object
- long **objectTypeId** - Required ID of the object type of the associated object
- String **associationPath** - Optional path of the object for use with hierarchies
- String **runTimeData** - Comma delimited ids of the record you want to filter from

TriggerActions – submit

- long **recordId** - Required ID of the record to trigger the action against
- String **actionName** - Required valid action name to call against the record ID specified

HttpSession – return

- long **id** - the id of the user currently logged in
- String **token** - the session token for the user currently logged in

Transition – return

- String **action** - the action name
- long **actionId** - the id of the action
- String **actionSequence** - order of the action for the particular state
- String **label** - the label of the action
- String **nextState** - the next state that the record will go to when this action is called.
- SubAction[] **subActions** - an array of SubAction objects.

SubAction – return

- String **action** - the action name
- long **actionId** - the id of the action
- String **label** - the label of the action

State – submit/return

- String **state** -The current state of the record
- long **recordId** - The recordId
- Transition[] **trans** - an array of Transition objects

Notices

This information was developed for products and services offered in the U.S.A.

IBM may not offer the products, services, or features discussed in this document in other countries. Consult your local IBM representative for information about the products and services currently available in your area. Any reference to an IBM product, program, or service is not intended to state or imply that only that IBM product, program, or service may be used. Any functionally equivalent product, program, or service that does not infringe any IBM intellectual property right may be used instead. However, it is the user's responsibility to evaluate and verify the operation of any non-IBM product, program, or service.

IBM may have patents or pending patent applications covering subject matter described in this document. The furnishing of this document does not grant you any license to these patents. You can send license inquiries, in writing, to:

IBM Director of Licensing
IBM Corporation
North Castle Drive
Armonk, NY 10504-1785
U.S.A.

For license inquiries regarding double-byte character set (DBCS) information, contact the IBM Intellectual Property Department in your country or send inquiries, in writing, to:

Intellectual Property Licensing
Legal and Intellectual Property Law
IBM Japan, Ltd.
19-21, Nihonbashi-Hakozakicho, Chuo-ku
Tokyo 103-8510, Japan

The following paragraph does not apply to the United Kingdom or any other country where such provisions are inconsistent with local law:

INTERNATIONAL BUSINESS MACHINES CORPORATION PROVIDES THIS PUBLICATION "AS IS" WITHOUT WARRANTY OF ANY KIND, EITHER EXPRESS OR IMPLIED, INCLUDING, BUT NOT LIMITED TO, THE IMPLIED WARRANTIES OF NON-INFRINGEMENT, MERCHANTABILITY OR FITNESS FOR A PARTICULAR PURPOSE. Some states do not allow disclaimer of express or implied warranties in certain transactions, therefore, this statement may not apply to you.

This information could include technical inaccuracies or typographical errors. Changes are periodically made to the information herein; these changes will be incorporated in new editions of the publication. IBM may make improvements and/or changes in the product(s) and/or the program(s) described in this publication at any time without notice.

Any references in this information to non-IBM Web sites are provided for convenience only and do not in any manner serve as an endorsement of those Web sites. The materials at those Web sites are not part of the materials for this IBM product and use of those Web sites is at your own risk.

IBM may use or distribute any of the information you supply in any way it believes appropriate without incurring any obligation to you.

Licensees of this program who want to have information about it for the purpose of enabling: (i) the exchange of information between independently created programs and other programs (including this one) and (ii) the mutual use of the information which has been exchanged, should contact:

IBM Corporation
2Z4A/101
11400 Burnet Road
Austin, TX 78758
U.S.A.

Such information may be available, subject to appropriate terms and conditions, including in some cases, payment of a fee.

The licensed program described in this document and all licensed material available for it are provided by IBM under terms of the IBM Customer Agreement, IBM International Program License Agreement or any equivalent agreement between us.

Information concerning non-IBM products was obtained from the suppliers of those products, their published announcements or other publicly available sources. IBM has not tested those products and cannot confirm the accuracy of performance, compatibility or any other claims related to non-IBM products. Questions on the capabilities of non-IBM products should be addressed to the suppliers of those products.

All statements regarding IBM's future direction or intent are subject to change or withdrawal without notice, and represent goals and objectives only.

This information contains examples of data and reports used in daily business operations. To illustrate them as completely as possible, the examples include the names of individuals, companies, brands, and products. All of these names are fictitious and any similarity to the names and addresses used by an actual business enterprise is entirely coincidental.

Privacy Policy Considerations

IBM Software products, including software as service solutions, ("Software Offerings") may use cookies or other technologies to collect product usage information, to help improve the end user experience, to tailor interactions with the end user or for other purposes. In many cases no personally identifiable information is collected by the Software Offerings. Some of our Software Offerings can help enable you to collect personally identifiable information. If this Software Offering uses cookies to collect personally identifiable information, specific information about this offering's use of cookies is set forth below.

This Software Offering does not use cookies or other technologies to collect personally identifiable information.

If the configurations deployed for this Software Offering provide you as customer the ability to collect personally identifiable information from end users via cookies and other technologies, you should seek your

own legal advice about any laws applicable to such data collection, including any requirements for notice and consent.

For more information about the use of various technologies, including cookies, for these purposes, see IBM's Privacy Policy at www.ibm.com/privacy and IBM's Online Privacy Statement at www.ibm.com/privacy/details in the section entitled "Cookies, Web Beacons and Other Technologies" and the "IBM Software Products and Software-as-a-Service Privacy Statement" at www.ibm.com/software/info/product-privacy/.

Trademarks

IBM, the IBM logo, ibm.com, and TRIRIGA are trademarks or registered trademarks of International Business Machines Corp., registered in many jurisdictions worldwide.

Java and all Java-based trademarks and logos are trademarks or registered trademarks of Oracle and/or its affiliates.

Other product and service names might be trademarks of IBM or other companies. A current list of IBM trademarks is available on the Web at "[Copyright and trademark information](http://www.ibm.com/legal/copytrade.shtml)" at www.ibm.com/legal/copytrade.shtml.