

IMS
15.4.0

System Definition
(2024-08-30 edition)



Note

Before you use this information and the product it supports, read the information in [“Notices” on page 977.](#)

2024-08-30 edition.

© **Copyright International Business Machines Corporation 1974, 2022.**

US Government Users Restricted Rights – Use, duplication or disclosure restricted by GSA ADP Schedule Contract with IBM Corp.

Contents

About this information.....	xiii
Prerequisite knowledge.....	xiii
How new and changed information is identified.....	xiii
How to read syntax diagrams.....	xiii
Accessibility features for IMS 15.4.....	xv
How to send your comments.....	xv
Chapter 1. Overview of the IMS system definition process.....	1
IMS system definition.....	1
How system definition is related to installation.....	1
Coding IMS macros that define the system.....	2
Choosing a system definition.....	5
Selecting the appropriate macros to define your system.....	5
System definition preprocessor overview.....	17
IMS stage 1 system definition.....	20
Verifying the stage 1 input.....	21
Determining when system definition is required.....	22
Including Fast Path in a DCCTL or DB/DC system definition.....	23
Including Fast Path in a DBCTL system definition.....	24
IMS stage 2 system definition.....	24
JCLIN processing.....	25
Applying maintenance using SMP/E.....	25
Adding entries to the z/OS Program Properties Table.....	25
Chapter 2. Dynamic resource definition.....	29
Overview of dynamic resource definition.....	29
Managing resource and descriptor definitions.....	31
Commands that support dynamic resource definition.....	33
Dynamic resource definition and system definition.....	36
Recovery of changed runtime resource and descriptor definitions.....	37
Overview of the IMSRSC repository.....	37
IMS ID information in the IMSRSC repository.....	40
Defining the IMSRSC repository.....	40
Resource lists for the IMSRSC repository.....	42
Requirements for dynamic resource definition.....	44
Restrictions for dynamic resource definition.....	45
Considerations for using dynamic resource definition.....	46
Enabling dynamic definition for IMS resource groups.....	48
Enabling dynamic resource definition for MODBLKS resources.....	49
Enabling dynamic definition for MSC resources.....	52
Creating runtime resource and descriptor definitions.....	53
Creating runtime database resource and descriptor definitions with the CREATE command.....	54
Creating runtime application program resource and descriptor definitions with the CREATE command.....	55
Creating runtime Fast Path routing code resource and descriptor definitions with the CREATE command.....	56
Creating runtime transaction resource and descriptor definitions with the CREATE command.....	56
Creating runtime resource and descriptor definitions in an IMSplex with the CREATE command...	57
Creating runtime MSC resource definitions with the CREATE command.....	57
Creating resource and descriptor definitions in the IMSRSC repository.....	58

Creating MODBLKS resource and descriptor definitions in the IMSRSC repository.....	58
Creating MSC resource definitions in the IMSRSC repository.....	60
Updating runtime resource and descriptor definitions.....	61
Updating runtime database resource and descriptor definitions with the UPDATE command.....	62
Updating runtime application program resource and descriptor definitions with the UPDATE command.....	63
Updating runtime Fast Path routing code resource and descriptor definitions with the UPDATE command.....	64
Updating runtime transaction resource and descriptor definitions with the UPDATE command.....	65
Updating runtime resource and descriptor definitions in an IMSplex with the UPDATE command..	66
Updating runtime MSC resource definitions with the UPDATE command.....	66
Updating resource and descriptor definitions in the IMSRSC repository.....	67
Updating MODBLKS resource and descriptor definitions in the IMSRSC repository for a single IMS or for multiple IMSs with unique definitions.....	67
Updating MODBLKS resource and descriptor definitions in the IMSRSC repository for multiple IMS systems with the same set of definitions.....	68
Updating MSC resource definitions in the IMSRSC repository.....	69
Deleting runtime resource and descriptor definitions.....	69
Deleting runtime database resource and descriptor definitions with the DELETE command.....	71
Deleting runtime application program resource and descriptor definitions with the DELETE command.....	72
Deleting runtime Fast Path routing code resource and descriptor definitions with the DELETE command.....	73
Deleting runtime transaction resource and descriptor definitions with the DELETE command.....	74
Deleting runtime resource and descriptor definitions in an IMSplex with the DELETE command....	75
Deleting runtime MSC resource definitions with the DELETE command.....	75
Deleting resource and descriptor definitions from the IMSRSC repository.....	76
Backing out DRD command-related changes made to your online system.....	77
Backing out DRD command-related changes to your online system with a cold start of IMS.....	77
Backing out DRD command-related changes to your online system without a cold start of IMS....	78
Backing out MSC DRD command-related changes to your online system.....	78
Exporting resource and descriptor definitions.....	79
Exporting MODBLKS resource and descriptor definitions to an RDDS.....	80
Exporting MODBLKS resource and descriptor definitions to an IMSRSC repository.....	81
Exporting MSC resource definitions to an IMSRSC repository.....	83
Importing resource and descriptor definitions.....	84
Importing MODBLKS resource and descriptor definitions by using the automatic import function.....	85
Importing MSC resource definitions by using the automatic import function.....	87
Importing resource and descriptor definitions from an RDDS by using the IMPORT command.....	88
Importing resource and descriptor definitions from the IMSRSC repository by using the IMPORT command.....	89
Backing out runtime resources imported with the IMPORT command.....	90
Maintaining your dynamic resource definition environment.....	91
Converting resource definitions into IMS stage 1 macro statements or IMS type-2 CREATE commands.....	95
Falling back from using the IMSRSC repository.....	95
Falling back from using the IMSRSC repository for MODBLKS resources.....	95
Falling back from using the IMSRSC repository for MSC resources without a stage-1 system definition.....	97
Falling back from using the IMSRSC repository for MSC resources with a stage-1 system definition.....	98
Disabling RM from using the repository and stopping the RS address spaces.....	99
Disabling dynamic resource definition	99
Disabling dynamic resource definition for MODBLKS resources.....	99
Disabling dynamic resource definition for MSC resources.....	101

Chapter 3. Designing the IMS system.....	103
Choosing the number of regions.....	103
Setting a checkpoint frequency.....	103
Selecting an IMS lock manager.....	104
Using a DL/I separate address space.....	105
Starting the DL/I separate address space.....	106
Allocating Message Format Service buffer pool space.....	107
Use of the message format buffer pool.....	108
Declaring online databases.....	109
Declaring online application programs.....	109
Defining online applications.....	112
Declaring Fast Path application programs.....	113
Defining IMS transactions.....	113
Defining Fast Path transactions.....	115
Planning a scheduling algorithm.....	116
Grouping application transactions in DB/DC and DCCTL environments.....	117
Stopping transactions and PSBs because of unavailable data.....	117
Assigning message class and initializing a region in DB/DC and DCCTL.....	118
Message priorities within message classes in DB/DC and DCCTL.....	118
Selection priorities for transactions in DB/DC and DCCTL environments.....	119
Processing limits for messages in DB/DC and DCCTL environments.....	120
Quick reschedule for regions in DB/DC and DCCTL environments.....	120
Pseudo WFI option for MPP regions in DB/DC and DCCTL environments.....	121
Processing transactions against unavailable data in DB/DC and DCCTL environments.....	122
Scheduling transactions using the suspend queue.....	122
Parallel scheduling of applications and transactions.....	124
Scheduling for BMP processing.....	124
Assigning priorities for programs with exclusive intent.....	124
Scheduling for CPI-Communications-driven programs.....	125
Defining terminals with data communication macros.....	125
Defining VTAM terminals.....	125
Defining non-VTAM devices.....	127
Choosing the IMS master terminal.....	128
Specifying macros for Multiple Systems Coupling.....	130
Using multiple IMS systems at the same release level and environment.....	131
Using multiple IMS systems at different release levels.....	132
Including IMS ETO in the IMS system.....	132
Defining an FDBR region.....	133
Configuration options for FDBR regions.....	134
Enabling an IMS subsystem for FDBR.....	135
IMSplex requirements for FDBR.....	136
Specifying enqueue and dequeue requirements.....	136
Specifying security options.....	136
Chapter 4. Allocating and cataloging IMS system resources.....	139
IMS system data sets for online change.....	139
Initializing system data sets when not using online change.....	142
IMS online data sets.....	143
Allocating ACBLIB data sets.....	144
Dynamically allocating the ACB staging library for ACBLIB member online change.....	145
Dynamically allocating the IMSACBA and IMSACBB library data sets.....	146
Allocating log data sets.....	147
Allocating online log data sets (OLDSs).....	148
Allocating the write-ahead data set (WADS).....	150
Allocating the system log data set (SLDS).....	152
Allocating the restart data set.....	153

Setting the TOD clock during IPL.....	153
Message queue data set allocation in DB/DC and DCCTL environments.....	153
Allocating OSAM data sets.....	155
Allocating VSAM data sets.....	156
Allocating data sets in extended address volumes.....	157
Resource definition data sets.....	158
Changing RDDS block sizes.....	159
IMSRSC repository and RS catalog repository data sets.....	160
Allocating RS catalog repository data sets.....	161
Allocating the IMSRSC repository data sets.....	163
IMS repository index and member data sets.....	164
IMS repository data set states.....	165
Allocating IMS spool data sets.....	166
Allocating direct output lines.....	169
Initializing the RECON data set for DBRC.....	170
Defining a HALDB indirect list data set.....	171
Defining large sequential data sets.....	171
Falling back from large sequential data sets.....	173
Defining Message Formatting Service.....	173
Implementing Message Formatting Service.....	175

Chapter 5. Specifying IMS execution parameters..... 177

System control and performance EXEC parameters for the IMS control region.....	177
Dynamic resource definition EXEC parameters.....	179
Database and PSB exec parameters for the control region.....	179
Database buffer requirements.....	179
Buffer sizes for databases that use OSAM or VSAM.....	179
Performance options for data management and program specification blocks.....	180
Data communication EXEC parameters for the control region.....	180
Fast Path EXEC parameters in DCCTL or DB/DC.....	182
Fast Path EXEC parameters in DBCTL.....	184
Fast Path dependent region parameters in DCCTL or DB/DC.....	185
Fast Path parameters in BMP and CCTL regions in DBCTL.....	186
Online DEDB utility region parameters in DCCTL, DBCTL, or DB/DC.....	187
Recovery-related EXEC parameters for the control region.....	187
Security-related EXEC parameters for the control region.....	189
EXEC parameters for IMS message processing regions.....	189
EXEC parameters for IMS batch message processing regions.....	192

Chapter 6. Tailoring the IMS system to your environment..... 197

Tailoring the sample procedures in the SDFSPROC data set.....	197
Running the DFSPROCB job to complete sample procedures.....	197
Creating procedures for specific subsystem types.....	197
Copying the sample procedures to the PROCLIB data set.....	198
Tailoring the IMS PROCLIB data set.....	198
Controlling the IMS PROCLIB data set.....	201
IMS buffer pools.....	206
VSAM subpool definition.....	207
OSAM subpool definition.....	208
OSAM buffer pool compatibility definition.....	208
Specifying VSAM and OSAM subpools.....	209
Specifications for OSAM sequential buffering.....	210
Creating and sizing the 64-bit storage pool.....	210
Making IMS and IMSRDR procedures accessible to z/OS.....	210
Organizing PL/I modules for use with the PL/I Optimizer.....	211
Specifying sequential buffering control statements.....	211
Using high-speed sequential processing control statements.....	212

Supporting CCTL users with DBCTL databases.....	212
Preparing a CCTL.....	213
Enabling IMS ETO for ACF/VTAM terminals.....	214
ETO descriptors.....	214
Logon descriptors.....	215
MFS device descriptors.....	216
MSC descriptors.....	217
User descriptors.....	217
Specifying the number of hash table slots.....	218
HALDB selective partition processing.....	218
Capturing JVM usage statistics.....	222
Format of an SMF type-29, subtype-2 record.....	223
STDENV shell scripting.....	226
Chapter 7. Provision IMS resources with z/OSMF.....	235
Provision an IMS DB/TM system.....	235
Provision Fast Path DEDB databases.....	236
Chapter 8. CQS definition and tailoring.....	237
CQS's support of multiple clients.....	237
Defining structure size for CQS connections.....	237
Calculating resource structure entry and element values to maximize storage.....	237
Preparing to start the CQS address space.....	242
Chapter 9. CSL definition and tailoring.....	245
Defining the Common Service Layer using IMS PROCLIB data set members.....	245
Sequence for starting CSL address spaces.....	247
Chapter 10. IMS catalog definition and tailoring.....	249
Setting up the IMS catalog.....	249
IMS management of ACBs.....	252
Enabling IMS management of ACBs.....	254
Falling back from IMS-managed ACBs to installation-managed ACBLIBs.....	259
References to ACB, DBD, and PSB resources when ACBs are managed by IMS.....	261
GSAM databases and IMS management of ACBs.....	261
Installing the IMS catalog DBDs and PSBs.....	262
IMS catalog data sets.....	263
Creating the database data sets of the IMS catalog manually.....	264
Size of IMS catalog data sets.....	266
IMS catalog data set groups.....	268
IMS directory data sets.....	269
Data set names of the IMS directory data sets.....	270
Defining the IMS catalog master database and partitions.....	271
Defining the IMS catalog with DBRC.....	271
Defining the IMS catalog without DBRC.....	272
Populating the IMS catalog by using IMS utilities.....	274
Input libraries required by the population utilities.....	275
DFSDFxxx member of the IMS.PROCLIB data set.....	276
Access type and the population utilities in a multi-system environment.....	276
Populating the IMS catalog using the ACB Generation and Catalog Populate utility (DFS3UACB).....	277
Populating the IMS catalog using the IMS Catalog Populate utility (DFS3PU00).....	279
Keeping the IMS catalog in sync with the active ACB library.....	281
The IMS catalog in multi-system configurations.....	283
Sharing an IMS catalog.....	284
DFSDFxxx members and the IMS catalog in multi-system configurations.....	285
Defining an IMS catalog alias name.....	285
IMS catalog multi-system configuration examples.....	287

Security for the IMS catalog.....	290
Copying an IMS catalog.....	291
Copying an IMS catalog that does not contain IMS-managed ACBs.....	291
Copying an IMS catalog that contains IMS-managed ACBs.....	292
Activity records for the IMS catalog.....	294
Format of IMS catalog activity records.....	294
Chapter 11. IMS Connect definition and tailoring.....	297
Sample JCL to start IMS Connect.....	297
Configuring IMS Connect.....	298
Defining IMS Connect security.....	300
Setting up AT-TLS SSL for IMS Connect.....	300
Configuring XML conversion support for IMS Connect clients.....	303
Configuring the IMS Base Primitive Environment for IMS Connect.....	306
Allocating IMS Connect log record data sets.....	307
JCL to print IMS Connect RECORDER output.....	308
Chapter 12. Enabling open access to IMS data.....	309
Chapter 13. IMS-to-IMS TCP/IP connections.....	311
Defining IMS-to-IMS TCP/IP connections for MSC.....	312
Example definitions for an MSC TCP/IP link.....	316
Defining a TCP/IP generic resource group for MSC.....	318
Defining IMS-to-IMS TCP/IP connections for OTMA.....	322
Example definitions for sending OTMA messages to a remote IMS system.....	324
Defining an IMS Connect super member group for OTMA IMS-to-IMS TCP/IP connections.....	324
Chapter 14. Accessing external subsystem data.....	327
Defining your external subsystems to IMS.....	327
Specifying the SSM= EXEC parameter.....	328
Defining the language interface module.....	329
Specifying trace options.....	330
Specifying Db2 for z/OS groups for IMS online regions.....	331
Specifying Db2 for z/OS for IMS batch regions.....	332
Preparing Db2 for z/OS for use with IMS.....	333
Providing appropriate tables in your ESS.....	333
Placing Db2 for z/OS modules and tables in the appropriate library.....	333
Configuring JMP and JBP regions for Db2 for z/OS data access.....	333
Attaching a Db2 for z/OS subsystem to IMS using RRSASF.....	334
Chapter 15. Setting up IMS for diagnostics.....	337
Setting the size of the z/OS trace tables.....	337
Common Storage Tracker.....	337
CHNGDUMP MAXSPACE.....	338
Automatic dump data set allocation.....	338
Diagnostic setup recommendations for IMS.....	339
CQS trace setup recommendations.....	341
Trace environment - conservative.....	341
Trace environment - more aggressive.....	341
Installing the IMS Dump Formatter.....	342
Making IMS.SDFSRESL available.....	343
Setting up the external trace environment.....	343
Controlling the volume of traces.....	343
Activating Fast Path traces.....	344
Writing trace tables externally.....	344
Creating output data sets with correct attributes.....	345
Setting up tracing for BPE-managed address spaces.....	345

Setting up type-2 trace tables.....	347
Setting up the IMS abend search and notification function.....	348
Customizing the IMS abend search and notification email.....	351
Chapter 16. IMS system definition examples.....	355
IMS DB/DC environment.....	355
Data communication characteristics.....	355
System configuration macro statements.....	355
Database and application macro statements.....	356
DL/I application programs.....	356
Data Communication macro statements.....	359
Local SYSOUT line groups.....	359
Macro statements to define VTAM communication devices.....	360
System configuration macro statement.....	371
IMS Multiple Systems Coupling system definition examples.....	371
Data-sharing system configuration.....	375
Data sharing at the database-level with update access.....	376
Data sharing at the database level with read access.....	377
Intra-CPC block-level data sharing.....	378
Inter-CPC block-level data sharing.....	379
IMS DBCTL environment.....	380
Chapter 17. IMS Syntax Checker.....	381
Function keys and the Syntax Checker.....	382
Starting the Syntax Checker.....	382
Syntax Checker online help.....	382
Using the Syntax Checker.....	383
IMS Release and Control Region panel.....	384
IMS Release panel.....	384
Keyword Display panel.....	385
Save Member prompt panel.....	392
SAVE AS prompt panel.....	392
IMS Parameter Syntax Checker panel.....	393
Chapter 18. Macros used in IMS environments.....	395
Reference information for using IMS macros.....	395
APPLCTN macro.....	400
COMM macro.....	407
DATABASE macro.....	415
DFSMDA macro.....	417
FPCTRL macro.....	427
IMSCTRL macro.....	427
MSGGEN macro.....	437
LINE macro.....	448
LINEGRP macro.....	450
MSGQUEUE macro.....	453
MSLINK macro.....	457
MSNAME macro.....	460
MSPLINK macro.....	461
NAME macro.....	465
RTCODE macro.....	469
SUBPOOL macro.....	470
TERMINAL macro.....	471
TRANSACT macro.....	498
TYPE macro.....	514
VTAMPOOL macro.....	516

Chapter 19. Procedures used in IMS environments..... 517

The specification of IMS procedures.....	517
Parameter descriptions for IMS procedures.....	520
ABND= through AUTO= procedure parameters.....	520
BKO= through CSLG= procedure parameters.....	525
DBBF= through DIRCA= procedure parameters.....	531
DLINM= through EXVR= procedure parameters.....	537
FBP= through HSBMBR= procedure parameters.....	540
IMS= through LHST= procedure parameters.....	545
LOCKMAX= through MNPSW= procedure parameters.....	550
MOD= through ORSMBR= procedure parameters.....	555
OTHR= through PIMAX= procedure parameters.....	559
PRDR= through QTU= procedure parameters.....	564
RC= through RVFY= procedure parameters.....	569
SAV= through SUF= procedure parameters.....	572
SVC2= through TLIM= procedure parameters.....	578
TRACE= through YEAR4= procedure parameters.....	580
DD statements for IMS procedures.....	583
CQS startup procedure.....	590
CSLODBM procedure	595
CSLOM procedure	597
CSLRM procedure.....	598
CSLSCI procedure.....	598
CSLURLFL procedure.....	599
DBBBATCH procedure.....	601
DBC procedure.....	604
DBRC procedure.....	609
DCC procedure.....	611
DFSASNO procedure.....	619
DFSJBP procedure.....	621
DFSJMP procedure.....	623
DFSMPR procedure.....	626
DLIBATCH procedure.....	628
DLISAS procedure.....	631
DXRJPROC procedure.....	633
FDR procedure.....	634
FPUTIL procedure.....	638
IMS procedure.....	639
IMSBATCH procedure.....	648
IMSCOBGO procedure.....	650
IMSCOBOL procedure.....	653
IMSDALOC procedure.....	654
IMSFP procedure.....	656
IMSMMSG procedure.....	657
IMSPLI procedure.....	657
IMSPLIGO procedure.....	659
IMSRDR procedure.....	661
RDIBATCH procedure.....	662
Repository Server procedure.....	664

Chapter 20. Members of the IMS PROCLIB data set.....665

BPE configuration parameter member of the IMS PROCLIB data set.....	665
BPE exit list members of the IMS PROCLIB data set.....	684
CQSIPxxx member of the IMS PROCLIB data set.....	692
CQSSLxxx member of the IMS PROCLIB data set.....	696
CQSSGxxx member of the IMS PROCLIB data set.....	699

CSLDCxxx member of the IMS PROCLIB data set.....	706
CSLDIxxx member of the IMS PROCLIB data set.....	711
CSLOIxxx member of the IMS PROCLIB data set.....	714
CSLRIxxx member of the IMS PROCLIB data set.....	719
CSLSIxxx member of the IMS PROCLIB data set.....	723
DBFMSTDBx member of the IMS PROCLIB data set.....	725
DFS62DTx member of the IMS PROCLIB data set.....	727
DFSCGxxx member of the IMS PROCLIB data set.....	728
DFSDCxxx member of the IMS PROCLIB data set.....	736
DFSDFxxx member of the IMS PROCLIB data set.....	756
CATALOG and CATALOGxxxx sections of the DFSDFxxx member.....	756
COMMON_SERVICE_LAYER section of the DFSDFxxx member.....	762
DATABASE section of the DFSDFxxx member.....	770
DDL section of the DFSDFxxx member.....	773
DIAGNOSTICS_STATISTICS section of the DFSDFxxx member.....	777
DYNAMIC_RESOURCES section of the DFSDFxxx member.....	780
FASTPATH section of the DFSDFxxx member.....	788
LOGGER section of the DFSDFxxx member.....	794
MSC section of the DFSDFxxx member.....	797
OSAMxxx section of the DFSDFxxx member.....	801
REPOSITORY section of the DFSDFxxx member.....	805
SHARED_QUEUES section of the DFSDFxxx member.....	806
USER_EXITS section of the DFSDFxxx member.....	806
VSAMxxx section of the DFSDFxxx member.....	810
DFSDRFnn member of the IMS PROCLIB data set.....	814
DFSDSCMx member of the IMS PROCLIB data set.....	815
Common format of ETO descriptor statements.....	816
Logon descriptor format and parameters.....	817
MFS device descriptor format and parameters.....	821
MSC descriptor format and parameters.....	822
User descriptor syntax and parameters.....	823
DFSDSCTy member of the IMS PROCLIB data set.....	827
DFSFDRx member of the IMS PROCLIB data set.....	828
DFSFIXnn member of the IMS PROCLIB data set.....	830
DFSHSBxx member of the IMS PROCLIB data set.....	834
DFSINTxx member of the IMS PROCLIB data set.....	839
DFSJVMAP member of the IMS PROCLIB data set.....	840
DFSJVMEV (JVM environment settings member).....	841
DFSJVMMS member of the IMS PROCLIB data set.....	844
DFSMPLxx member of the IMS PROCLIB data set.....	845
DFSORSxx member of the IMS PROCLIB data set.....	847
DFSPBxxx member of the IMS PROCLIB data set.....	847
DFSSPMxx member of the IMS PROCLIB data set.....	849
DFSSQxxx member of the IMS PROCLIB data set.....	854
DFSVSMxx member of the IMS PROCLIB data set.....	857
Defining Fast Path DEDB buffer pools for single-area structures.....	860
Defining Fast Path DEDB buffer pools for multi-area structures.....	861
Defining VSAM buffer pools.....	862
Defining VSAM subpools.....	863
Defining VSAM performance options.....	866
Defining OSAM subpools.....	868
Requesting that z/OS dynamic allocation use extended storage.....	871
Specifying sequential buffering for an online system.....	871
Defining serviceability and trace options.....	871
Defining DL/I call image trace.....	880
Defining DASD logging initialization parameters.....	881
Defining IMS batch without dynamic allocation.....	881
Disabling the re-opening of databases after an IMS restart.....	881

Defining coupling facility structure names for sysplex data sharing.....	881
Using the coupling facility for OSAM data caching.....	883
Enabling the long busy handling function.....	884
Enabling the IRLM lock timeout function.....	885
Preventing transactions from being terminated when HALDB partitions are unavailable.....	886
Preventing DBRC calls for HALDB version verification.....	886
Resuming an online reorganization for HALDBs during IMS warm or emergency restart.....	887
Discarding preallocated SDEP control intervals.....	887
Preventing a /DBRECOVERY command for a database that has INDOUBT EEQEs.....	888
Removing the limit for the number of DFS3314W messages issued.....	888
DFSYDTx member of the IMS PROCLIB data set.....	888
OTMA client descriptor syntax and parameters.....	888
OTMA destination descriptor syntax and parameters.....	895
DFSOTMA descriptor syntax and parameters.....	902
DSPBIxxx member of the IMS PROCLIB data set.....	909
FRPCFG member of the IMS PROCLIB data set.....	911
HWSCFGxx member of the IMS PROCLIB data set.....	917
ADAPTER statement.....	918
DATASTORE statement.....	919
HWS statement.....	923
IMSPLEX statement.....	928
ISC statement.....	929
MSC statement.....	932
ODACCESS statement.....	934
RMTCICS statement.....	938
RMTIMSCON statement.....	939
TCPIP statement.....	943
IMS Connect configuration examples.....	949
Chapter 21. Other control statements used in IMS environments.....	957
Sequential buffering control statements.....	957
High-speed sequential processing control statements.....	963
Set Index Maintenance Off (SETI) control statement.....	968
Database resource adapter startup table for CCTL regions.....	968
DFSDFSRT.....	972
IMS Installation Defaults module (DFSIDEF0).....	973
Notices.....	977
Programming interface information.....	978
Trademarks.....	978
Terms and conditions for product documentation.....	979
IBM Online Privacy Statement.....	979
Bibliography.....	981
Index.....	983

About this information

These topics provide guidance information for designing an IMS system, including information about defining and tailoring the IMS system, IMS Common Queue Server (CQS), IMS Common Service Layer (CSL), IMS catalog, IMS Connect, IMS-to-IMS TCP/IP connections, and dynamic resource definition (DRD). The topics also include descriptions of the IMS macros, procedures, and members of the IMS PROCLIB data set.

This information is available in [IBM® Documentation](#).

Prerequisite knowledge

Before using this information, you should have knowledge of either IMS Database Manager (DB) or IMS Transaction Manager (TM). You should also understand basic z/OS® and IMS concepts, your installation's IMS system, and have general knowledge of the tasks involved in project planning.

To learn about z/OS, see [z/OS Basic Skills](#). For more resources, see [IBM Z Education and Training](#).

To learn about IMS, see the IBM Press publication *An Introduction to IMS*, the resources listed for [IBM Information Management System](#), and the variety of options available in [IBM Training](#).

How new and changed information is identified

For most IMS library PDF publications, information that is added or changed after the PDF publication is first published is denoted by a character (revision marker) in the left margin. The *Program Directory* and *Licensed Program Specifications* do not include revision markers.

Revision markers follow these general conventions:

- Only technical changes are marked; style and grammatical changes are not marked.
- If part of an element, such as a paragraph, syntax diagram, list item, task step, or figure is changed, the entire element is marked with revision markers, even though only part of the element might have changed.
- If a topic is changed by more than 50%, the entire topic is marked with revision markers (so it might seem to be a new topic, even though it is not).

Revision markers do not necessarily indicate all the changes made to the information because deleted text and graphics cannot be marked with revision markers.

How to read syntax diagrams

The following rules apply to the syntax diagrams that are used in this information:

- Read the syntax diagrams from left to right, from top to bottom, following the path of the line. The following conventions are used:
 - The >>--- symbol indicates the beginning of a syntax diagram.
 - The ---> symbol indicates that the syntax diagram is continued on the next line.
 - The >--- symbol indicates that a syntax diagram is continued from the previous line.
 - The --->< symbol indicates the end of a syntax diagram.
- Required items appear on the horizontal line (the main path).

▶▶ *required_item* ◀◀

- Optional items appear below the main path.

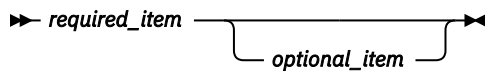

If an optional item appears above the main path, that item has no effect on the execution of the syntax element and is used only for readability.

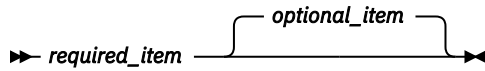

- If you can choose from two or more items, they appear vertically, in a stack. If you *must* choose one of the items, one item of the stack appears on the main path.

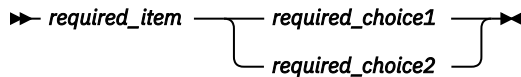

If choosing one of the items is optional, the entire stack appears below the main path.

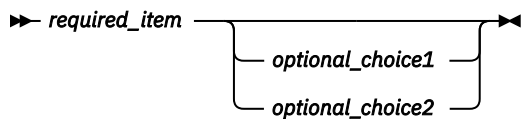

If one of the items is the default, it appears above the main path, and the remaining choices are shown below.

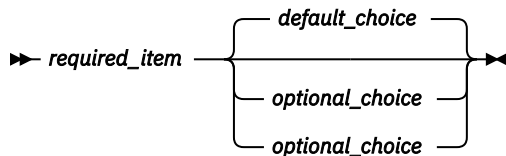

- An arrow returning to the left, above the main line, indicates an item that can be repeated.

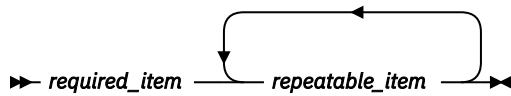

If the repeat arrow contains a comma, you must separate repeated items with a comma.

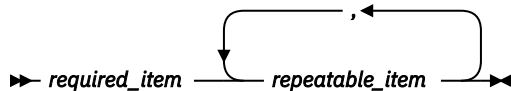

A repeat arrow above a stack indicates that you can repeat the items in the stack.

- Sometimes a diagram must be split into fragments. The syntax fragment is shown separately from the main syntax diagram, but the contents of the fragment should be read as if they are on the main path of the diagram.

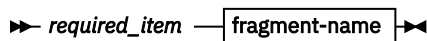

fragment-name

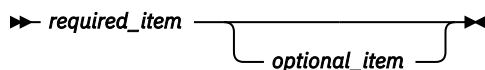

- In IMS, a b symbol indicates one blank position.

- Keywords, and their minimum abbreviations if applicable, appear in uppercase. They must be spelled exactly as shown. Variables appear in all lowercase italic letters (for example, *column-name*). They represent user-supplied names or values.
- Separate keywords and parameters by at least one space if no intervening punctuation is shown in the diagram.
- Enter punctuation marks, parentheses, arithmetic operators, and other symbols, exactly as shown in the diagram.
- Footnotes are shown by a number in parentheses, for example (1).

Accessibility features for IMS 15.4

Accessibility features help a user who has a physical disability, such as restricted mobility or limited vision, to use information technology products successfully.

Accessibility features

The following list includes the major accessibility features in z/OS products, including IMS 15.4. These features support:

- Keyboard-only operation.
- Interfaces that are commonly used by screen readers and screen magnifiers.
- Customization of display attributes such as color, contrast, and font size.

Keyboard navigation

You can access IMS 15.4 ISPF panel functions by using a keyboard or keyboard shortcut keys.

For information about navigating the IMS 15.4 ISPF panels using TSO/E or ISPF, refer to the *z/OS TSO/E Primer*, the *z/OS TSO/E User's Guide*, and the *z/OS ISPF User's Guide Volume 1*. These guides describe how to navigate each interface, including the use of keyboard shortcuts or function keys (PF keys). Each guide includes the default settings for the PF keys and explains how to modify their functions.

Related accessibility information

Online documentation for IMS 15.4 is available in IBM Documentation.

IBM and accessibility

See the *IBM Human Ability and Accessibility Center* at www.ibm.com/able for more information about the commitment that IBM has to accessibility.

How to send your comments

About this task

Your feedback is important in helping us provide the most accurate and highest quality information. If you have any comments about this or any other IMS information, you can take one of the following actions:

Procedure

- Submit a comment by using the DISQUS commenting feature at the bottom of any [IBM Documentation](#) topic.
- Send an email to imspubs@us.ibm.com. Be sure to include the book title.
- Click the **Contact Us** tab at the bottom of any [IBM Documentation](#) topic.

What to do next

To help us respond quickly and accurately, please include as much information as you can about the content you are commenting on, where we can find it, and what your suggestions for improvement might be.

Chapter 1. Overview of the IMS system definition process

The IMS system definition process describes the system resources (databases, applications, devices, terminals, and links) to IMS when you first install IMS, you apply maintenance to your IMS system, or definition changes are required.

IMS system definition

IMS system definition at a high-level view comprises several supertasks.

Before you begin

You should have a working knowledge of the z/OS system modification program/extended (SMP/E). SMP/E is required for installation and is used as part of the IMS system definition process.

About this task

IMS system definition is evolving to be more dynamic rather than static.

Procedure

1. Modify or tailor IMS-supplied macro statements and procedures (JCL) to define the IMS system that your business requires. These macro statements and procedures are the building blocks for your IMS system.
2. Run the IMS preprocessor to verify the correctness of the macros and procedures.
3. Execute Stage 1 assembly, in which you run the JCL that you modified in step 1 through the z/OS High Level Assembler program to assemble your program into the JCL that is required as input to Stage 2.
4. Execute Stage 2 assembly, in which you:
 - a) Build the IMS executable load modules.
 - b) Optionally build Message Format Service (MFS) default formats.
 - c) Update the member of the IMS PROCLIB data set.
5. Run the JCLIN, an SMP/E process that tells SMP/E how to assemble and bind modules.
6. Use the SMP/E APPLY command to process any maintenance that has not been processed using the SMP/E ACCEPT command.

How system definition is related to installation

System definition and JCL preparation are only a part of the total installation process. You should understand the relationship between installation and system definition before defining your system.

Related reading: For step-by-step instructions on installing an IMS system, see *IMS Version 15.4 Installation*.

A full installation process includes:

1. Building IMS system libraries
2. Allocating and cataloging IMS data sets
3. Defining the IMS system
4. Preparing the operating system for IMS, including:
 - VTAM®
 - RACF®

- APPC/MVS™
5. Installing IMS exit routines
 6. Tailoring IMS buffers and certain performance options
 7. Defining terminals (VTAM and non-VTAM)
 8. Updating MFS device characteristics table and MFS default formats
 9. Defining LU 6.2 descriptors
 10. Defining ETO descriptors
 11. Building IMS.DBDLIB
 12. Building IMS.PSBLIB
 13. Building IMS.ACBLIB
 14. Preparing for dynamic allocation of databases and related system data sets
 15. Compiling message format descriptions
 16. Loading application programs
 17. Initial loading of databases
 18. Establishing IMS security
 19. Initializing IMS.MODSTAT
 20. Copying staging libraries to active libraries

Coding IMS macros that define the system

Use IMS macros to define and tailor a new IMS system or to modify an existing IMS system.

The first step in defining an IMS system is to modify or tailor the macros that IMS supplies. The composite of all IMS macro statements becomes *stage 1 input*; during stage 1, the specifications you make on the macros are checked, and a series of z/OS job steps is generated as input to Stage 2. Within each set of macro statements, individual macros specify data that is specific to a required function or to a part of the total physical online configuration of your IMS system.

There are seven types of IMS system definition that can be performed. The IMSCTRL macro provides the basic IMS control program options and the z/OS system configuration under which IMS is to execute:

Table 1. Seven types of IMS System Definitions

System definition option used on IMSCTRL macro	Components that are generated	When to use this option
ALL	Builds most IMS modules and procedures. Includes BATCH and ON-LINE types too.	Use ALL during a typical initial system definition. This option is also often required for maintenance.
BATCH	Moves required modules from IMS distribution libraries to your libraries; generates a database system.	Use BATCH only to define an IMS batch environment.
CTLBLKS	Generates modules for all IMS control blocks. A CTLBLKS system definition type also includes the MODBLKS and MSVERIFY types.	Use CTLBLKS to rebuild the existing IMS nucleus and to create communications definitions.
MSVERIFY	Builds control blocks for the Multiple Systems Verification utility (DFSUMSV0).	Use MSVERIFY only for Multiple Systems Coupling (MSC).

Table 1. Seven types of IMS System Definitions (continued)

System definition option used on IMSCTRL macro	Components that are generated	When to use this option
MODBLKS	Generates control block members for resources to be added online (for example, APPLCTN, DATABASE, TRANSACT, and RTCODE macros).	Use MODBLKS when online changes are required to the IMS system, such as changes to programs, transactions, and database definitions.
NUCLEUS	Generates an IMS nucleus for the control region. A NUCLEUS system definition type also includes the CTLBLKS type.	Use NUCLEUS when performing major maintenance that affects the contents of the IMS nucleus, or when a new nucleus with a new suffix is required.
ON-LINE	Builds all the modules needed for the online IMS environment. An ON-LINE system definition type also includes the NUCLEUS type.	Use ON-LINE during initial system definition or to perform a major update. This option is also often required for maintenance.

You can think of these groupings of macros as a type of hierarchical structure, as shown in [Figure 1 on page 4](#). The group of required system configuration macros (IMSCTRL, MSGQUEUE, SECURITY, and COMM) is shown as a root segment.

Hierarchy of Stage 1 system definition macros

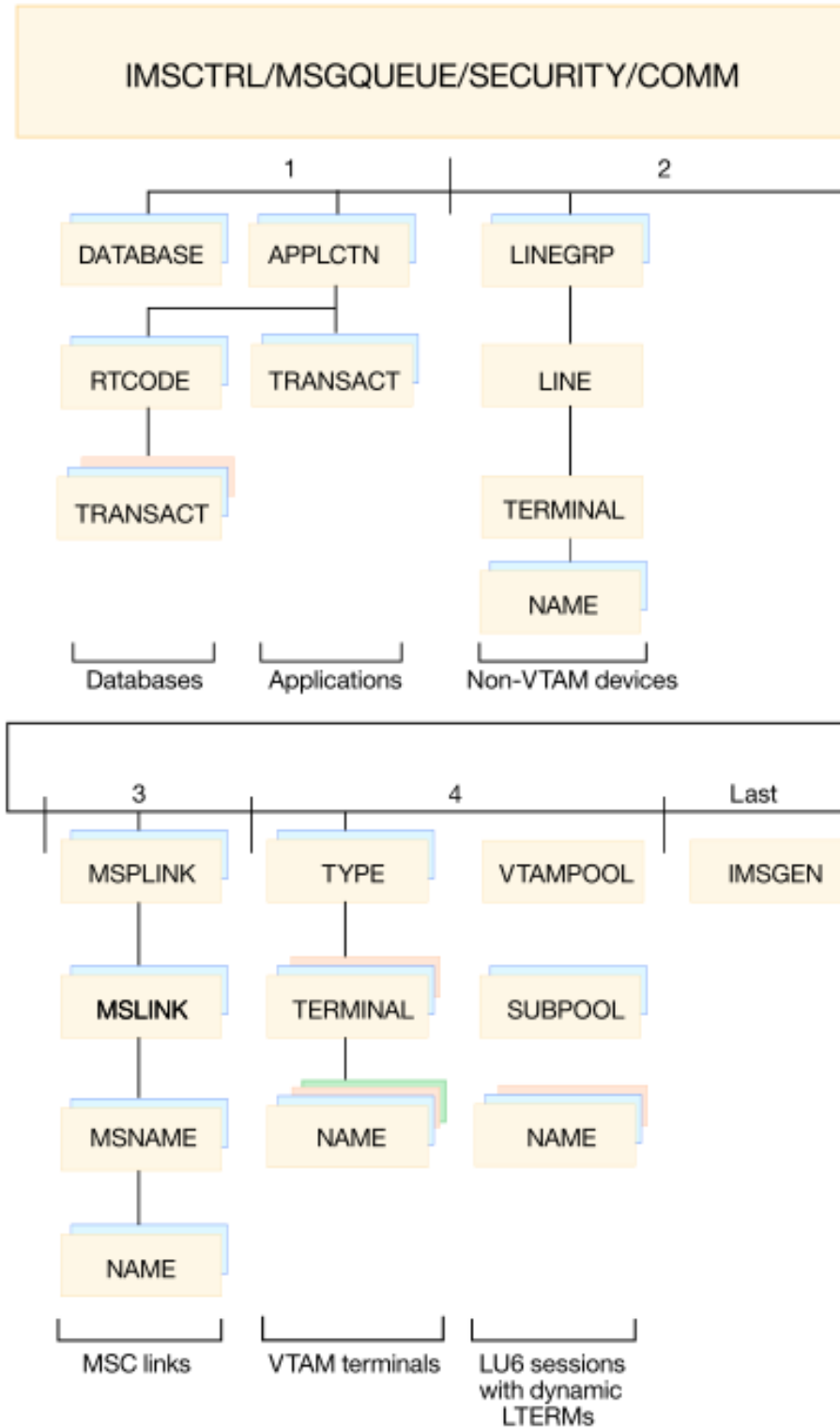

Figure 1. Hierarchy of stage 1 system definition macros

Restriction: The IMSGEN macro must be the last macro defined.

Choosing a system definition

Use the SYSTEM= parameter on the IMSCTRL macro to choose the type of system you want to define.

Use the IMSCTRL SYSTEM= parameter to identify the system you want to define:

DB/DC

Builds an IMS system that includes both the Database Manager (DB) and Transaction Manager (DC)

DBCTL

Builds an IMS system that includes only the Database Manager

DCCTL

Builds an IMS system that includes only the Transaction Manager

After you initially define your IMS system, you can later use the ON-LINE, CTLBLKS, and NUCLEUS options to implement changes. The ON-LINE, CTLBLKS, and NUCLEUS options require a cold start of the IMS online system to take effect.

For certain changes to your IMS system, you can take advantage of the online change method using the MODBLKS type of system definition. With the MODBLKS type of system definition, the changes are made active during the execution of the online system and do not require a restart operation.

Selecting the appropriate macros to define your system

When you choose to define or modify an IMS system, the system definition parameters that you can define or modify vary by the type of system definition. Certain macro statements, keywords, and parameters require additional consideration if you are newly adding or entirely deleting them from the system.

The following table of macros shows, in order of complexity, which IMS system definition parameters can be modified by type of system definition. You can override some keywords for some macros by specifying certain keyword parameters on the EXEC statement for the IMS, DBC, or DCC procedure, or by modifying the JCL. Other keywords can also be overridden through IMS commands. For further information, see Chapter 6, “Tailoring the IMS system to your environment,” on page 197 or the notes that follow the table.

To use the following table, find the macro-associated keyword and parameter that you want to change. Then scan across the table to find the first column with an "X" under the system definition types. This identifies the minimum system definition required to change the parameter. If multiple changes are to be made, scan each macro statement on the figure to determine the minimum system definition. When changing operands, make certain the minimum system definition required to update the operand is performed. If you specify a lower level than that indicated in the following table the results are unpredictable.

The JCL column in the table identifies the EXEC parameter, DFSPBIMS keyword, DFSPBDBC keyword, DFSPBDCC keyword, or, IMS command to override the operand in the macro.

Keywords and parameters changed during a MODBLKS system definition can be brought online through a series of /MODIFY operator commands, except as described in the notes that follow the table below.

The CTLBLKS system definition option on the IMSCTRL macro statement can be used only to replace the control blocks of an existing nucleus—that is, a nucleus having the same suffix.

Adding new device support features or options might require a NUCLEUS system definition, because additional modules (for example, the VTAM terminal COPY option and module DFSCVEQ0) might need to be bound into the nucleus.

Some of the values can be displayed using the /DISPLAY command shown in table notes. The value in the /DISPLAY column is used to qualify the /DISPLAY command as necessary.

Table 2. Macro Table - Selecting the appropriate IMS system definition

Macro	Operand	Value	JCL or Command	/DISPLAY	MO DB LK S	CT LB LK S	NU CL EU S	ON -LI NE	AL L	M SV ER IF Y	DB BA TC H	TM BATCH	D BC TL	D B/ D C	D CC TL	Notes
APPLCTN	DOPT				X	X	X	X	X				X	X	X	"33" on page 14
	PGMTYPE	class	/ASSIGN		X	X	X	X	X					X	X	"20" on page 14
		All others			X	X	X	X	X				X	X	X	
	RESIDENT				X	X	X	X	X				X	X	X	
	FPATH				X	X	X	X	X					X	X	
	SYSID				X	X	X	X	X					X	X	"1" on page 13
	All Others				X	X	X	X	X				X	X	X	
COMM	COPYLOG		/SMCOPY			X	X	X	X					X	X	
	OPTIONS	NOFMAS FMTMAS					X	X	X					X	X	
		NOMFSTEST MFSTEST					X	X	X					X	X	"2" on page 13
		NOPAGE PAGING					X	X	X					X	X	
		All Others				X	X	X	X					X	X	
	RECANY					X	X	X	X					X	X	"3" on page 13, "4" on page 13
	All Others					X	X	X	X					X	X	

Table 2. Macro Table - Selecting the appropriate IMS system definition (continued)

Macro	Operand	Value	JCL or Command	/DISPLAY	MO DB LK S	CT LB LK S	NU CL EU S	ON -LI NE	AL L	M SV ER IF Y	DB BA TC H	TM BATCH	D BC TL	D B/ D C	D CC TL	Notes
DATABASE	ACCESS		DD		X	X	X	X	X				X	X		"1" on page 13, "6" on page 13, "7" on page 13, "31" on page 14, "32" on page 14, "34" on page 14
			/START		X	X	X	X	X				X	X		"1" on page 13, "22" on page 14
	RESIDENT				X	X	X	X	X				X	X		
	All Others				X	X	X	X	X				X	X		
IDLIST						X	X	X	X							
IMSCTRL	CMDCHAR		CRC=			X	X	X	X				X	X		
	DBRC	parm 1	DBRC=						X		X	X	X	X		"9" on page 13
		parm 2	DBRC=						X		X	X	X	X		"9" on page 13
	DBRCNM		DBRCNM=			X	X	X	X				X	X		"2" on page 13, "23" on page 14
	DCLWA					X	X	X	X					X		
	DESC					X	X	X	X				X	X		
	DLINM		DLINM=			X	X	X	X				X	X		"2" on page 13, "23" on page 14

Table 2. Macro Table - Selecting the appropriate IMS system definition (continued)

Macro	Operand	Value	JCL or Command	/DISPLAY	MO DB LK S	CT LB LK S	NU CL EU S	ON -LI NE	AL L	M SV ER IF Y	DB BA TC H	TM BATCH	D BC TL	D B/ D C	D CC TL	Notes
	ETOFEAT							X	X					X	X	
	GSGNAME		GSGNAME=					X	X		X	X	X	X	X	"29" on page 14
	HSB							X	X					X	X	"11" on page 13
	IMSID		IMSID=			X	X	X	X			X	X	X	X	"2" on page 13
	IRLM		IRLM=			X	X	X	X			X	X	X		"2" on page 13, "10" on page 13, "30" on page 14
	IRLMNM		IRLMNM=			X	X	X	X			X	X	X		"2" on page 13, "10" on page 13, "30" on page 14
	MAXCLAS					X	X	X	X			X		X	X	
	MAXREGN		PST=			X	X	X	X				X	X	X	"2" on page 13
	MCS					X	X	X	X			X	X	X	X	
	MSVID					X	X	X	X	X			X	X	X	
	NAMECHK					X	X	X	X			X	X	X	X	
	RSRFEAT							X	X		X	X	X	X	X	
	SYSTEM							X	X		X	X	X	X	X	
	TMINAME		TMINAME=			X		X	X		X	X	X	X	X	"29" on page 14

Table 2. Macro Table - Selecting the appropriate IMS system definition (continued)

Macro	Operand	Value	JCL or Command	/DISPLAY	MO DB LK S	CT LB LK S	NU CL EU S	ON -LI NE	AL L	M SV ER IF Y	DB BA TC H	TM BATCH	D BC TL	D B/ D C	D CC TL	Notes
IMSGEN	MFSDFMT					X	X	X	X					X	X	
	MFTST						X	X	X				X	X	X	"2" on page 13
	PSWDSEC					X	X	X	X				X	X	X	
	SECCNT						X	X	X				X	X	X	
	SUFFIX						X	X	X				X	X	X	
	SURVEY								X				X	X		"12" on page 13
	SYMSG					X	X	X	X					X	X	
	All Others					X	X	X	X	X		X	X	X	X	
LINE	ADDR		DD			X	X	X	X					X	X	"13" on page 13, "24" on page 14
	All Others					X	X	X	X					X	X	
LINEGRP						X	X	X	X					X	X	"14" on page 13
MSGQUEUE	BUFFERS	NBR	QBUF=			X	X	X	X					X	X	"2" on page 13
		SIZE				X	X	X	X					X	X	
	All Others					X	X	X	X					X	X	
MSLINK						X	X	X	X					X	X	
MSNAME						X	X	X	X					X	X	

Table 2. Macro Table - Selecting the appropriate IMS system definition (continued)

Macro	Operand	Value	JCL or Command	/DISPLAY	MO DB LK S	CT LB LK S	NU CL EU S	ON -LI NE	AL L	M SV ER IF Y	DB BA TC H	TM BATCH	D BC TL	D B/ D C	D CC TL	Notes
MSPLINK	ADDR		<ul style="list-style-type: none"> • DD • UPDATE MSPLINK command 			X	X	X	X					X	X	"13" on page 13, "15" on page 14, "25" on page 14
	MODETBL		/CHANGE	link# MODE		X	X	X	X					X	X	"26" on page 14
	OPTIONS	asr	/CHANGE			X	X	X	X					X	X	"25" on page 14
	TYPE					X	X	X	X					X	X	"15" on page 14, "16" on page 14
	All Others					X	X	X	X					X	X	
NAME						X	X	X	X					X	X	"17" on page 14
RTCODE					X	X	X	X	X					X	X	"35" on page 14
SUBPOOL						X	X	X	X					X	X	
TERMINAL	MODETBL		/CHANGE	nodename NAME		X	X	X	X					X	X	"27" on page 14
	OPTIONS	asr	/CHANGE			X	X	X	X					X	X	"28" on page 14
	All Others					X	X	X	X					X	X	
TRANSACTION	AOI	yes/tran/cmd			X	X	X	X	X					X	X	"36" on page 14
	DCLWA		UPDATE TRAN		X	X	X	X	X					X	X	

Table 2. Macro Table - Selecting the appropriate IMS system definition (continued)

Macro	Operand	Value	JCL or Command	/DISPLAY	MO DB LK S	CT LB LK S	NU CL EU S	ON -LI NE	AL L	M SV ER IF Y	DB BA TC H	TM BATCH	D BC TL	D B/ D C	D CC TL	Notes
	EDIT	name	UPDATE TRAN			X	X	X						X	X	"18" on page 14, "19" on page 14
		All Others	UPDATE TRAN		X	X	X	X	X					X	X	
	EXPTIME	NBR	UPDATE TRAN		X	X	X	X	X					X	X	"1" on page 13
	MAXRGN		• /CHANGE • UPDATE TRAN		X	X	X	X	X					X	X	"20" on page 14
	MSGTYPE	class	/ASSIGN		X	X	X	X	X					X	X	"1" on page 13, "20" on page 14
		All Others	UPDATE TRAN		X	X	X	X	X					X	X	
	PARLIM		• /ASSIGN • UPDATE TRAN		X	X	X	X	X					X	X	"1" on page 13, "20" on page 14
	PROCLIM	count	/ASSIGN		X	X	X	X	X					X	X	"1" on page 13, "20" on page 14
		All Others			X	X	X	X	X					X	X	
	PRTY		/ASSIGN		X	X	X	X	X					X	X	"1" on page 13, "20" on page 14
	SEGNO		• /ASSIGN • UPDATE TRAN		X	X	X	X	X					X	X	"1" on page 13, "20" on page 14
	SEGSIZE		• /ASSIGN • UPDATE TRAN		X	X	X	X	X					X	X	"1" on page 13, "20" on page 14

Table 2. Macro Table - Selecting the appropriate IMS system definition (continued)

Macro	Operand	Value	JCL or Command	/DISPLAY	MO DB LK S	CT LB LK S	NU CL EU S	ON -LI NE	AL L	M SV ER IF Y	DB BA TC H	TM BATCH	D BC TL	D B/ D C	D CC TL	Notes
	SYSID				X	X	X	X	X					X	X	"1" on page 13
	All Others				X	X	X	X	X					X	X	
TYPE	OPTIONS		SIGNON=			X	X	X	X					X	X	"4" on page 13, "14" on page 13
VTAMPOOL						X	X	X	X					X	X	

Notes to the preceding table:

1. Changes to existing transactions cannot be introduced through a MODBLKS online change if those attributes are changeable by online commands. It is recommended that you enable dynamic resource definition for MODBLKS resources to dynamically update existing transactions. You can use the /ASSIGN or /CHANGE commands to change existing transactions, but the command needs to be reissued after you perform a local online change or a global online change, before the affected transactions are scheduled. Dynamically updating transactions allows you to avoid issuing and then reissuing the /ASSIGN or /CHANGE commands for the existing transactions.
2. Refer to [“IMS procedure” on page 639](#), [“DBBATCH procedure” on page 601](#), [“DBC procedure” on page 604](#), [“DCC procedure” on page 611](#), and [“DLIBATCH procedure” on page 628](#).
3. This keyword can be changed with any type of system definition except MODBLKS.
4. Adding or deleting VTAM support requires the minimum of an ON-LINE system definition.
5. Adding a user-supplied exit routine, user message table, or the shared printer message router exit routine requires the minimum of a CTLBLKS system definition. The exceptions to this requirement are the ETO, message greeting, and command security exit routines. To remove the use of these exit routines requires a minimum of NUCLEUS system definition. These exit routines are then loaded or deleted during initialization if they are in IMS.SDFSRESL.
6. The ACCESS attribute is used in data sharing and can be dynamically changed with the /START command.
7. ACCESS can be forced to exclusive by specifying DISP=OLD in the database DD statement or in the DFSMDA definition.
8. Although the value for the Type 2 SVC number is changed in the necessary control blocks for all system definition types, only the ON-LINE and ALL types of system definition bind the SVC module into IMS.SDFSRESL with the proper name required for subsequent bind into the operating system libraries.
9. The DBRC= parameter on the IMSCTRL macro is ignored by IMS.
10. For an online system, modifying the IRLM= or IRLNM= parameters requires a minimum of a CTLBLKS type system definition. A batch system requires a minimum of either a BATCH or an ALL system definition.
11. Generating a system for use in an IMS backup configuration requires a minimum of an ON-LINE system definition.
12. Adding Database Surveyor support to an IMS system initially generated without it can be done in two ways. If done through system definition, either a BATCH system definition (for batch) or an ALL system definition (for both batch and online) must be specified to include Surveyor. Alternatively, in either a batch or online system, the following JCL can be run:

```
//LINKSUR JOB
//          EXEC PGM=IEWL,REGION=128K,
//          PARM='NCAL,LET,XREF'
//SYSPRINT DD SYSOUT=A
//LOAD     DD DSN=IMS.ADFSLOAD,DISP=SHR
//SYSLMOD  DD DSN=IMS.SDFSRESL,DISP=SHR
//SYSUT1   DD SPACE=(CYL,(1,1)),UNIT=SYSDA
//SYSLIN   DD *
INCLUDE LOAD(DFSRSPUR)
INCLUDE LOAD(DFSLI000)
NAME DFSRSPUR(R)          DATABASE SURVEYOR
/*
```

13. Change the DD statement.
14. Adding or deleting support for a specific non-ETO terminal type requires a minimum of a NUCLEUS system definition. A minimum of a NUCLEUS system definition is required if the SIZE= or FEAT= parameter is specified for the first time in an existing system or if the values of these parameters are changed. You can use any type of system definition except MODBLKS to add, delete, or change this macro statement.

15. Adding MSC support for the first time or deleting MSC support requires a minimum of an ON-LINE system definition. A physical link change requires a DD statement change.
16. Adding or deleting channel-to-channel support requires a minimum of an ON-LINE system definition. Adding MSC TCP/IP, VTAM, or MTM support requires a minimum of an ON-LINE system definition. Deleting MSC TCP/IP, VTAM, or MTM support requires a minimum of a NUCLEUS system definition.
17. Removing remote LTERM support from an MSC system requires a minimum of a NUCLEUS system definition.
18. MODBLKS system definition cannot be used to add a transaction that is also adding a new user edit routine. MODBLKS system definition cannot be used to change the order of the transactions if user edit routines are specified. The minimum system definition for either of these occurrences is a CTLBLKS system definition.
19. MODBLKS system definition cannot be used to delete a transaction that has a user edit routine if this is the first or only transaction that is using this edit routine. MODBLKS system definition cannot be used to change the order of the transactions if user edit routines are specified. The minimum system definition for either of these occurrences is a CTLBLKS system definition.
20. The command is /DISPLAY TRANSACTION.
21. The command is /DISPLAY POOL xxxx, where xxxx is the indicated parameter.
22. The command is /DISPLAY DATABASE.
23. The command is /DISPLAY ACTIVE.
24. The command is /DISPLAY LINE.
25. The command is /DISPLAY LINK.
26. The command is /DISPLAY LINK xxxx, where xxxx is the indicated parameter.
27. The command is /DISPLAY NODE.
28. The command is /DISPLAY MODE xxxx, where xxxx is the indicated parameter.
29. For batch systems, specify the parameter in the JCL; for online systems, specify the parameter in the DFSRSRxx member.
30. A BATCH or ALL system definition is required for the change to take effect in a batch environment.
31. A database that is defined in an ALL or MODBLKS system definition cannot be converted into a HALDB partition without a cold start of IMS. A cold start is required even if the database is deleted online. After the cold start, the database must be redefined as a HALDB partition.
32. A database that is defined as a HALDB partition to DBRC and IMS cannot be redefined in an ALL or MODBLKS system definition without a cold start of IMS. A cold start is required even if the database is deleted online.
33. The APPLCTN macro is optional in DBCTL, DB/DC, and DCCTL environments. No warning message is issued if the macro is not included in the Stage 1 system definition. If you exclude the APPLCTN macro from your Stage 1 system definition, application programs must then be defined through the dynamic resource definition (DRD) process.
34. The DATABASE macro is optional in DBCTL and DB/DC environments. No warning message is issued if the macro is not included in the Stage 1 system definition. If you exclude the DATABASE macro from your Stage 1 system definition, databases must then be defined through the dynamic resource definition (DRD) process.
35. The RTCODE macro is optional in DB/DC and DCCTL environments. No warning message is issued if the macro is not included in the Stage 1 system definition. If you exclude the RTCODE macro from your Stage 1 system definition, routing codes must then be defined through the dynamic resource definition (DRD) process.
36. The TRANSACT macro is optional in DB/DC and DCCTL environments. No warning message is issued if the macro is not included in the Stage 1 system definition. If you exclude the TRANSACT macro from your Stage 1 system definition, transactions must then be defined through the dynamic resource definition (DRD) process.

Related reference

“Macros used in IMS environments” on page 395

These topics provide general information about using IMS macros.

System definition preprocessor overview

Use the IMS system definition preprocessor to ensure that stage 1 input does not include duplicate resource names, such as transaction codes, LTERMs, and system names.

IMS provides a preprocessor that you can use to check the stage 1 input for duplicate names among the names you have defined. The preprocessor also ensures that the names are of the correct length and format. Assigned names are checked across resource types, too, so that transaction codes, LTERMs, and IMS system names (used for multiple systems coupling) do not contain duplications. The preprocessor helps maintain the integrity of the stage 1 input stream.

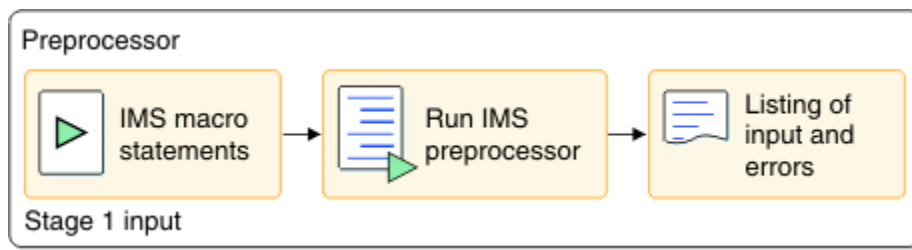

Figure 2. The preprocessor stage of the system definition process

The system definition preprocessor is optional.

If the IMSCTRL NAMECHK=NO option is selected for IMS system definition, run the system definition preprocessor.

Stage 1 source statements are used as input and can include copy statements. However, they cannot include inline copies of IMS macros from the stage 1 input, inline user macros, user macro calls, or conditional assembler statements.

The preprocessor locates, reads, and processes copy statements by using the copy members as input. The order of search, which conforms to z/OS standards, depends upon the order in which you have concatenated the libraries. Copy members are retrieved from the data sets specified by SYSLIB DD statements. The preprocessor scans the input for the following IMS macros:

- APPLCTN
- DATABASE
- MSLINK
- MSNAME
- MSPLINK
- NAME
- RTCODE
- SUBPOOL
- TERMINAL
- TRANSACT

The preprocessor does not recognize keywords that are split across continuation statements. The related parameters associated with these keywords generate error messages from the preprocessor.

After scanning for macros, the preprocessor builds resource name tables for each resource name type. It then performs the following verification steps:

- Within each resource type, the preprocessor verifies that no resources of that type have duplicate names. The following types of resource names are verified:

- DBD names
- PSB names
- VTAM node names
- MS link names
- Logical terminal names
- Transaction codes
- Routing codes
- Subpool names
- MSLINK partner IDs
- MSPLINK physical link names
- Remote system VTAM node names
- These resource names are checked to ensure that they are of the appropriate length and are alphanumeric.
- The names specified for transactions, logical terminals, and multiple systems are cross-checked to ensure that no duplicate names exist across these three resource types.

Also see the following sections of this overview of the systems definition preprocessor:

- [“Estimating storage requirements for the preprocessor” on page 18](#)
- [“Preprocessor exit routines” on page 19](#)
- [“Sample JCL to execute the preprocessor” on page 19](#)

Estimating storage requirements for the preprocessor

The preprocessor uses the default values to reserve an initial amount of storage for each resource name table (RNT). If this storage is insufficient, the preprocessor dynamically expands the table until all extended private storage is exhausted. Resource names not added to the appropriate RNT are ignored and excluded from further processing.

Additional space is required if the number of errors for any given resource name exceeds 50, or if the number of nested copy statements exceeds 50. For most cases, this additional storage is accounted for in the base system storage number.

The storage size is the minimum region size that can be specified on preprocessor invocation JCL.

The preprocessor also requires 1 MB of private storage below the 16 MB line.

Standard system definition:

The storage estimate is for extended private storage. The storage requirement is the sum of:

1. 1000 KB for the base system.
2. Space needed for exit routines DFSPRE60 and DFSPRE70, if they are loaded.
3. Table space in excess of the default. For each of the following resource types that exceeds 5120, determine the amount of storage from [Table 3 on page 19](#).
 - APPLCTN
 - DATABASE
 - NAME
 - RTCODE
 - SUBPOOL
 - TERMINAL (VTAM)

- TRANSACT

Table 3. Resource name table storage

Resource range	Storage amount in K bytes
5120 to 10,240	80
10,240 to 20,480	240
20,480 to 41,060	560
41,060 to 82,120	1200
82,120 to 164,240	2480
164,240 to 328,480	5040
328,480 to 656,960	10,160
656,960 to 1,313,920	20,400

Preprocessor exit routines

You can develop exit routines that gain control during the execution of the preprocessor. You can use one or both of the following exit routines:

- Exit DFSPRE60

This routine gains control after each record in the stage 1 input is read, but before any other processing takes place. It can modify the contents of the record and can even submit further statements to the preprocessor for checking. Any changes made by this routine are not permanent, nor are these changes automatically passed to stage 1.

- Exit DFSPRE70

This routine gains control when all cross-checking has been completed. It has access to all the tables of resource names. The routine can then format these tables as part of a documentation effort.

Sample JCL to execute the preprocessor

To execute the preprocessor, you must provide JCL as shown in the following example.

```
//          JOB
//          EXEC PGM=DFSPRE00,REGION=32M,PARM='xxx' 1
//STEPLIB DD DSN=IMS.SDFSRESL,DISP=SHR 2
//          DD DSN=USER.EXITLIB,DISP=SHR 3
//SYSLIB  DD DSN=USER.MACLIB,DISP=SHR 4
//          DD DSN=IMS.SDFSMAC,DISP=SHR 4
//SYSPRINT DD SYSOUT=A
//SYSIN   DD * 5
```

Notes:

1. The region size indicated is the size required to execute the preprocessor on a z/OS system. Guidelines for determining the region sizes are in [“Estimating storage requirements for the preprocessor”](#) on page 18.
The PARM field is specified only if the default exit routine indicators should be overridden.
2. This DD statement should specify the library containing the preprocessor version that you want to execute. Different versions can exist because of SMP maintenance.
3. This concatenated DD statement is required only if exit routines are requested.

4. The SYSLIB DD statement should point to a library that contains the copy members. This DD statement is required if stage 1 source COPY statements exist.
5. You can also use the statement:

```
//SYSIN DD DSN=...,DISP=SHR
```

The PARM field on the EXEC statement is specified as follows:PARM= ' a , b '

The parameters specified are positional and are specified as follows:

a

Indicates whether (Y) or not (N) exit routine DFSPRE60 is to be used during this invocation of the preprocessor. If DFSPRE60 is to be used, it must reside on the libraries pointed to by the STEPLIB DD statement. The default is N.

b

Indicates whether (Y) or not (N) exit routine DFSPRE70 is to be used during this invocation of the preprocessor. If DFSPRE70 is to be used, it must reside on the libraries pointed to by the STEPLIB DD statement. The default is N.

IMS stage 1 system definition

Stage 1 of IMS system definition takes the IMS macros that you coded and assembles them into Stage 2 JCL.

Stage 1 of the system definition process uses the z/OS High Level Assembler program and uses the IMS macros as input. Other references are to the IMS distribution macro libraries (IMS.ADFSMAC).

The output from stage 1 of the IMS system definition process includes:

- Standard assembler listing output with any appropriate error messages.
- Stage 2 system definition input JCL, which is also used for the JCLIN process.

Depending on what is specified in the IMSGEN macro for stage 1, stage 2 of the system definition process can be divided up into a single job with multiple steps, or into many jobs with fewer steps.

You specify the assembler and binder data sets and options, and the system definition output options and features in the IMSGEN macro.

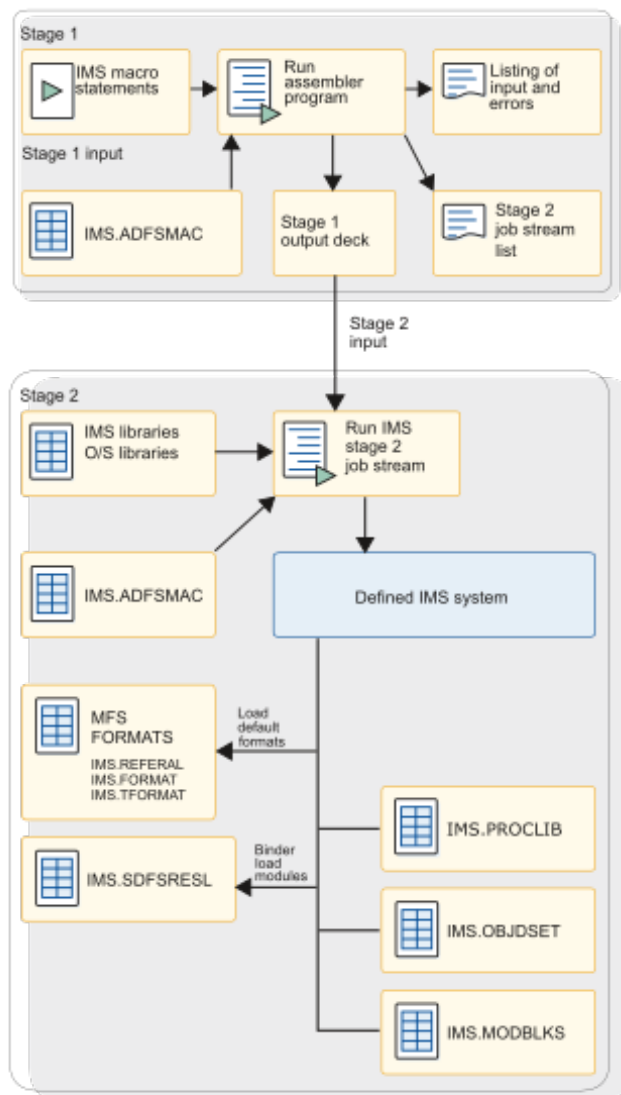

Figure 3. Stage 1 and Stage 2 of the system definition process

Verifying the stage 1 input

After stage 1 input is built, resource names are checked for validity uniqueness. You can bypass name checking to reduce overall processing.

Stage 1 input contains a structured definition of many resources to be used by the IMS online control program. It is important that you verify the content of the stage 1 input and the accuracy of the macro statement coding. The two kinds of verification are:

- Resource name checks
- Macro statement checks

Resource name checks

The names of resources are important not only from a documentation standpoint (conformance to naming conventions), but also from an operational standpoint. An LTERM name could be explicitly used by the MTO or it can be coded in an application program. As such, the resource names must be unique. Also, IMS reserves the use of certain resource names.

Stage 1 verifies that resource names are valid and appropriately unique. A benefit of this checking is to ensure that conflicts between resource definitions are detected before the control block building that takes place in stage 2. Some installations regularly execute stage 1 to perform this checking.

Macro statement checks

Because definite sequence requirements and dependencies exist between the parameter specifications, the macro statement checking performed in stage 1 is also valuable.

An option is available that reduces the processing performed by stage 1. The NAMECHK parameter on the IMSCTRL macro lets you bypass name checking—assuming you have made sure that no invalid or duplicate resource names exist. If your installation has made use of the optional preprocessor and you are checking a sizeable stage 1 input, specifying NAMECHK=NO can reduce the processing performed by stage 1. You can also specify that the sort is not performed in stage 1. (Specify S2 as the second value for the NAMECHK parameter.) When you perform the system definition and execute both stage 1 and stage 2, the default of NAMECHK=(YES,S1) is recommended so that full checking is part of the definition process.

You should track the progress of the stage 1 runs and, if necessary, investigate any detected problems.

Determining when system definition is required

You do not have to perform a complete system definition each time a parameter value changes.

For example, you can use JCL parameters to implement some system definition changes. However, if you add application programs (excluding APPC/IMS), databases, or physical changes (excluding ETO) to the network, redefinition of the IMS system is required. Use the SYSTEM keyword of the IMSCTRL macro to define different types of system definition.

Specifying alternative versions of an online system

You can define different configurations of the IMS online system. The control modules in the nucleus and control blocks carry a one-character suffix. You specify this suffix with the SUFFIX= keyword on the IMSGEN macro. The default value is 0 (zero). The value specified for the control region parameter SUF= controls which IMS configuration is to be executed.

System definition stage 1 output

A successful stage 1 execution generates the following output:

- An extensive series of self-contained jobs.
- Warning messages, which are embedded within a listing of your input source.
- A trailer to this listing containing instructions on the content and execution of the stage 2 job stream.

Because the amount of stage 2 processing time is significant, you should review the stage 1 messages carefully. A misplaced NAME macro or misspelled LTERM name can cause service to be unavailable to an end user and require an additional stage 2 execution.

Stage 2 processing builds a control program, often called a *nucleus*, which is tailored according to the specifications you made in stage 1. The control program, along with most of the internal control blocks, is placed in the IMS.SDFSRESL data set.

The SYSTEM keyword on the IMSCTRL macro determines the extent of stage 2 processing.

Including Fast Path in a DCCTL or DB/DC system definition

During a DCCTL or DB/DC system definition process, you can specify which Fast Path application programs and resources should be included in the IMS system.

About this task

Fast Path drives relatively simple transaction and database processing through the IMS system at high transaction rates. You must assess whether the combination of Fast Path regions and other regions, as well as the increased requirement for control program storage, can be supported in your system definition.

To include the Fast Path control program facilities and to reserve certain resources for Fast Path in an IMS online system, specify FP=Y in the DFSPBxxx member in the IMS PROCLIB data set. To include Fast Path processing and transactions in a DCCTL system, specify FP=Y in the DFSPBxxx member in the IMS PROCLIB data set.

If you specify FP=N, and you attempt to use a Fast Path resource or command, the results are unpredictable.

To specify Fast Path options and buffer sizes for an IMS online system, use the Fast Path parameters in the IMS procedure or the Fast Path section of the DFSDFxxx PROCLIB member.

You do not need to include the Fast Path parameters for a DCCTL system because Fast Path parameters apply only to Fast Path databases, and the DCCTL environment does not support Fast Path databases. Although the DCCTL environment does not support Fast Path databases, it does support Fast Path processing and transactions.

Use the following macros to describe the Fast Path application programs and associated resources:

APPLCTN

Declares the application programs

RTCODE

Directs input messages to Fast Path programs

TRANSACTION

Declares the transaction code and processing characteristics

In an IMS DB/DC system, you can specify the following keyword parameters:

OTHR

Keyword specifying how many output threads are to be used for the asynchronous DEDB update processing.

The OTHR= parameter can have any value from 1 to 32,767. If a value is not specified, the default is 255. If 0 or a value greater than 32767 is specified, the default is 2. If a value from 1 to 32767 is specified, the specified value is used.

DBFX

Keyword specifying the number of buffers to be set aside for DEDB updates used by sync point processing. These buffers are part of the total number given for DBBF.

DBBF

Keyword specifying the maximum number of buffers available to the online system for MSDB and DEDB processing. The range for both numbers is 1 - 4²⁹⁴967²⁹⁵. The default values are 4 for MSDBs and 10 for DEDBs.

BSIZ

Keyword specifying the actual size of an individual buffer. The control interval size is 512 bytes, 1⁵KB, 2⁵KB, 4⁵KB, or a multiple of 4⁵KB (up to 28⁵KB), depending on the size of the largest control interval (CI) used for DEDB processing.

FPBP64x

Specifies a number of Fast Path 64-bit buffer manager options. If you choose to use the Fast Path 64-bit buffer manager (FPBP64=Y), the DBBF, DBFX, and BSIZ parameters that define Fast Path buffers

are ignored. For complete information about the FPBP64x parameters, see [“DFSDFxxx member of the IMS PROCLIB data set” on page 756](#).

Including Fast Path in a DBCTL system definition

During the DBCTL system definition process, you can specify which Fast Path application programs and resources should be included in the IMS system.

About this task

Describe Fast Path application programs as part of system definition input with:

- The FP=Y keyword in the DFSPBxxx member of the IMS.PROCLIB data set, which causes Fast Path facilities to be included in the IMS online system and reserves certain resources for Fast Path.

If you specify FP=N, and you attempt to use a Fast Path resource or command, the results are unpredictable.

- The APPLCTN macro, which creates the application program definitions.

You use a system environment macro to specify Fast Path control program facilities in an IMS DBCTL environment in the same way that you use macros to specify options and buffer sizes.

Use the OTHR parameter of the IMS procedure to specify how many output threads are to be used for the asynchronous DEDB update processing.

The OTHR= parameter can have any value from 1 to 32,767. If a value is not specified, the default is 255. If 0 or a value greater than 32767 is specified, the default is 2. If a value from 1 to 32767 is specified, the specified value is used.

Use the DBFX parameter of the IMS procedure to specify the number of buffers to be set aside for DEDB updates used by sync point processing. These buffers are part of the total number given for the next parameter, DBBF. The DBBR parameter is used to specify the maximum number of buffers available to the online system for DEDB processing. Use the BSIZ parameter to specify the actual size of an individual buffer.

Related reference

[“APPLCTN macro” on page 400](#)

The APPLCTN macro allows you to define the program resource requirements for application programs that run under the control of the IMS DB/DC environment, and for application programs that access databases through DBCTL.

[“IMS procedure” on page 639](#)

The IMS procedure is an online execution procedure that initializes the IMS DB/DC environment.

[“DFSPBxxx member of the IMS PROCLIB data set” on page 847](#)

Use the three forms of the DFSPBxxx member of the IMS PROCLIB data set, DFSPBDBC, DFSPBDCC, and DFSPBIMS, to specify execution parameters for the DBCTL, DCCTL, and DB/DC control regions, respectively.

IMS stage 2 system definition

IMS stage 2 system definition assembles and binds all the modules that are required to build the necessary load modules, depending on what type of system is being defined.

The steps involved in stage 2 refer to the IMS distribution macro library (IMS.ADFSMAC) at assembly time, and the distribution load library (IMS.ADFSLOAD) at bind time.

Tip: If you are generating large numbers of transactions, consider coding the IMSGEN macro with **ONEJOB=(YES,NO|YES)**. Doing so ensures that stage 2 of IMS system definition does not run in parallel with stage 1 and, therefore, that assembly during stage 2 completes successfully. If large numbers of transactions are generated during IMS stage 2 system definition and **ONEJOB=(YES,NO|YES)** is not coded, stage 2 might fail intermittently.

The output of stage 2 of the system definition process includes:

- Executable load modules in data sets IMS.SDFSRESL and IMS.MODBLKS.
- Assembled object code for use in later system definition steps in data sets IMS.OBJDSET.
- Optionally, the runtime IMS.PROCLIB data set which contains members required by IMS and IMS utilities to provide options.
- Optionally, the runtime IMS default MFS screens in data sets IMS.FORMAT, IMS.TFORMAT, and IMS.REFERAL.

The MFSDFMT= parameter in the IMSGEN stage 1 macro determines whether the default message format screens are built as part of stage 2 of the system definition process.

Related reference

[“IMSGEN macro” on page 437](#)

Use the IMSGEN macro to specify the assembler and binder data sets and options, and the system definition output options and features.

JCLIN processing

The JCLIN process ensures that SMP/E knows how to manage any maintenance that is added to the system following an IMS system definition.

Because the stage 2 system definition process actually assembles and binds the IMS modules based on the definitions for that particular system and is run outside of SMP/E control, the input JCL for system definition stage 2 must be used as input to the JCLIN process. This input JCL ensures that SMP/E knows how to manage any maintenance that is added to the system following this IMS system definition.

Run the JCLIN process following any IMS system definition, to ensure that SMP/E is always synchronized with the updated IMS.

Applying maintenance using SMP/E

Use SMP/E to apply and accept IMS maintenance before an IMS system definition.

All IMS system definitions use the IMS SMP/E distribution libraries and the IMS stage 1 macros as input. As a result, an IMS system definition might reverse the changes from any SMP/E maintenance (SYSMODs - PTFs, APARs, or USERMODs) that was processed using the SMP/E APPLY command, but not processed using the SMP/E ACCEPT command. This depends on the type of IMS system definition, and the impact of the SYSMOD.

Related reading: For more information about performing SMP/E maintenance on IMS, see [IMS service considerations \(System Administration\)](#).

Adding entries to the z/OS Program Properties Table

Use the z/OS Program Properties Table (PPT) to identify a list of programs that require special attributes, or to change the attributes of the IBM-supplied default entries.

About this task

In an IMS environment, you must update the PPT for the following IMS components or address spaces:

- IMS control region
- Base Primitive Environment
- Common Queue Server
- Common Service Layer
- IMS Connect
- IRLM

For more information about updating the program properties table, see the topic on the SCHEDxx SYS1.PARMLIB member in *z/OS MVS Initialization and Tuning Reference*

Procedure

1. Edit the SCHEDxx member of the SYS1.PARMLIB data set.
2. Add the entry for the component or address space to the SCHEDxx member. Examples are shown below.
3. To make the SCHEDxx changes effective, you can do one of the following:
 - a) IPL the z/OS system again.
 - b) Issue the z/OS SET SCH= command.

Example

Updating the PPT for the IMS control region

An IMS online environment (DB/DC, DBCTL, DCCTL) requires this PPT entry.

Although DFSMVR0 is predefined in the default PPT that is shipped with z/OS V1R4 and later, you must ensure that there is an entry for module DFSMVR0 in the z/OS Program Properties Table. If you did not modify the default z/OS PPT, no further action is required. If you removed the default entry for DFSMVR0, you must reinstate this entry using the procedure above.

If you are only using IMS BATCH, this entry is not needed.

A sample of the required entry is shown below and can be found in the IMS.INSTALIB data set. See "IVP jobs and tasks" in *IMS Version 15.4 Installation* for the correct entry titled "Update SCHEDxx -- PPT Entries".

```

PPT PGMNAME(DFSMVR0) /* IMS ONLINE CONTROL REGION */
      CANCEL /* PROGRAM NAME = DFSMVR0 */
      KEY(7) /* PROGRAM CAN BE CANCELLED */
      NOSWAP /* PROTECT KEY ASSIGNED IS 7 */
      NOPRIV /* PROGRAM IS NOT-SWAPPABLE */
      SYST /* PROGRAM IS NOT PRIVILEGED */
      DSI /* PROGRAM IS A SYSTEM TASK */
      PASS /* DOES REQUIRE DATA SET INTEGRITY */
      AFF(NONE) /* PASSWORD PROTECTION ACTIVE */
      /* NO CPU AFFINITY */

```

The PPT Entry for program DFSMVR0 must specify NOSWAP as shown.

Updating the PPT for BPE

Although BPEINI00 is predefined in the default PPT that is shipped with z/OS, you must ensure that there is an entry for module BPEINI00 in the z/OS Program Properties Table. If you did not modify the default z/OS PPT, no further action is required. If you removed the default entry for BPEINI00, you must reinstate this entry using the procedure above.

Separate PPT entries for BPE-based DBRC and for IMS Connect are not required.

```

PPT PGMNAME(BPEINI00) /* PROGRAM NAME = BPEINI00 */
      CANCEL /* PROGRAM CAN BE CANCELED */
      KEY(7) /* PROTECT KEY ASSIGNED IS 7 */
      NOSWAP /* PROGRAM IS NON-SWAPPABLE */
      NOPRIV /* PROGRAM IS NOT PRIVILEGED */
      DSI /* REQUIRES DATA SET INTEGRITY */
      PASS /* CANNOT BYPASS PASSWORD PROTECTION */
      SYST /* PROGRAM IS A SYSTEM TASK */
      AFF(NONE) /* NO CPU AFFINITY */

```

Updating the PPT for CQS

If you are using CQS, either the CQSINIT0 or the BPEINI00 z/OS PPT entry is required.

Although CQSINIT0 and BPEINI00 are predefined in the default PPT that is shipped with z/OS V1R4 and later, you must ensure that there is an entry for module CQSINIT0 or BPEINI00 in the z/OS Program

Properties Table. If you did not modify the default z/OS PPT, no further action is required. If you removed the default entries for CQSINIT0 and BPEINI00, you must reinstate at least one of those entries using the procedure above.

A sample of the CQSINIT0 entry is shown below and can be found in the IMS.INSTALIB data set.

```

PPT PGMNAME(CQSINIT0) /* CQS - COMMON QUEUE SERVER */
/* PROGRAM NAME = CQSINIT0 */
CANCEL /* PROGRAM CAN BE CANCELLED */
KEY(7) /* PROTECT KEY ASSIGNED IS 7 */
NOSWAP /* PROGRAM IS NOT-SWAPPABLE */
NOPRIV /* PROGRAM IS NOT PRIVILEGED */
SYST /* PROGRAM IS A SYSTEM TASK */
DSI /* DOES REQUIRE DATA SET INTEGRITY */
PASS /* PASSWORD PROTECTION ACTIVE */
AFF(NONE) /* NO CPU AFFINITY */
NOPREF /* NO PREFERRED STORAGE FRAMES */

```

The PPT Entry for program CQSINIT0 must specify NOSWAP as shown.

Updating the PPT for CSL

The Common Service Layer (CSL), which consists of address spaces operations manager (OM), resource manager (RM), and structured call interface (SCI), requires an entry in the PPT. Only one entry is necessary for the CSL.

Although BPEINI00 is predefined in the default PPT that is shipped with z/OS V1R4 and later, you must ensure that there is an entry for module BPEINI00 in the z/OS Program Properties Table. If you did not modify the default z/OS PPT, no further action is required. If you removed the default entry for BPEINI00, you must reinstate this entry using the procedure above.

```

PPT PGMNAME(BPEINI00) /* CSL - COMMON SERVICE LAYER */
/* PROGRAM NAME = BPEINI00 */
CANCEL /* PROGRAM CAN BE CANCELLED */
KEY(7) /* PROTECT KEY ASSIGNED IS 7 */
NOSWAP /* PROGRAM IS NOT-SWAPPABLE */
NOPRIV /* PROGRAM IS NOT PRIVILEGED */
DSI /* REQUIRES DATA SET INTEGRITY */
PASS /* CANNOT BYPASS PASSWORD PROTECTION */
SYST /* PROGRAM IS A SYSTEM TASK */
AFF(NONE) /* NO CPU AFFINITY */

```

Updating the PPT for IMS Connect

IMS Connect uses the predefined z/OS Program Properties Table entry BPEINI00, but HWSHWS00 is also supported.

If using BPEINI00, you must ensure that there is an entry for module BPEINI00 in the z/OS Program Properties Table. If you did not modify the default z/OS PPT that was predefined in the default PPT that is shipped with z/OS V1R4 and later, no further action is required. If you removed the default entry for BPEINI00, you must reinstate this entry using the procedure above.

The examples shown below use HWSHWS00 instead of BPEINI00.

You can include both entries in the PPT, for example, in an environment that runs both IMS Connect Version 11 and IMS Connect Version 12.

For TCP/IP communications only, add the following entry in the z/OS PPT:

```

PPT PGMNAME(HWSHWS00) /* PROGRAM NAME = HWSHWS00 */
CANCEL /* PROGRAM CAN BE CANCELED */
KEY(7) /* PROTECT KEY ASSIGNED IS 7 */
SWAP /* PROGRAM IS SWAPPABLE */
NOPRIV /* PROGRAM IS NOT PRIVILEGED */
DSI /* REQUIRES DATA SET INTEGRITY */
PASS /* CANNOT BYPASS PASSWORD PROTECTION */
SYST /* PROGRAM IS A SYSTEM TASK */
AFF(NONE) /* NO CPU AFFINITY */

```

If you are using local option for client communications, either by itself or with TCP/IP communications, add the following entry in the z/OS PPT:

```
PPT PGMNAME(HWSHWS00) /* PROGRAM NAME = HWSHWS00 */
      CANCEL /* PROGRAM CAN BE CANCELED */
      KEY(7) /* PROTECT KEY ASSIGNED IS 7 */
      NOSWAP /* PROGRAM IS NOT SWAPPABLE */
      NOPRIV /* PROGRAM IS NOT PRIVILEGED */
      DSI /* REQUIRES DATA SET INTEGRITY */
      PASS /* CANNOT BYPASS PASSWORD PROTECTION */
      SYST /* PROGRAM IS A SYSTEM TASK */
      AFF(NONE) /* NO CPU AFFINITY */
```

Updating the PPT for IRLM

If you are using IRLM, the following z/OS PPT entry is required.

Although DXRRLM00 is predefined in the default PPT that is shipped with z/OS V1R4 and later, you must ensure that there is an entry for module DXRRLM00 in the z/OS Program Properties Table. If you did not modify the default z/OS PPT, no further action is required. If you removed the default entry for DXRRLM00, you must reinstate this entry using the procedure above.

A sample of the required entry is shown below and can be found in the IMS.INSTALIB data set.

```
PPT PGMNAME(DXRRLM00) /* IRLM - RESOURCE LOCK MANAGER */
      CANCEL /* PROGRAM NAME = DXRRLM00 */
      KEY(7) /* PROGRAM CAN BE CANCELLED */
      NOSWAP /* PROTECT KEY ASSIGNED IS 7 */
      NOPRIV /* PROGRAM IS NOT-SWAPPABLE */
      SYST /* PROGRAM IS NOT PRIVILEGED */
      DSI /* PROGRAM IS A SYSTEM TASK */
      PASS /* DOES REQUIRE DATA SET INTEGRITY */
      AFF(NONE) /* PASSWORD PROTECTION ACTIVE */
      /* NO CPU AFFINITY */
```

The PPT Entry for program DXRRLM00 must specify NOSWAP as shown.

Chapter 2. Dynamic resource definition

You can create, update, or delete certain IMS resources and add them to your IMS system dynamically, thereby eliminating the need to use the batch system definition or online change processes. This process is called the dynamic resource definition (DRD) process.

Only certain IMS resources, which are organized by groups of resource types, support dynamic definition. The following resource groups support dynamic definition:

- MODBLKS resources, which include definitions for runtime attributes of application programs, databases, Fast Path routing codes, and transactions. MODBLKS resources are so named because when dynamic resource definition is not used, these resources are generated into the MODBLKS data set by the IMS system definition process.
- MSC resources, which include definitions for MSC physical links, logical links, logical link paths, and remote logical terminals.

Related concepts

[“Overview of the IMSRSC repository” on page 37](#)

A repository is a generalized data storage facility that can be used to store any type of information. The IMS resource definition (IMSRSC) repository is a set of VSAM key sequenced data sets (KSDSs) used for storing information. The IMSRSC repository is a repository to store resource (and descriptor) definitions for IMS databases, transactions, programs, and routing codes. This repository is an alternative to the resource definition data set (RDDS) that is used with the dynamic resource definition (DRD) function.

Overview of dynamic resource definition

With dynamic resource definition (DRD), you can use type-2 commands to define MODBLKS resources such as application programs, databases, routing codes, and transactions, and resource descriptors, and MSC resources such as definitions for MSC physical links, logical links, logical link paths, and remote logical terminals.

MODBLKS resources

For IMS systems in which DRD for MODBLKS resources is not enabled or is unavailable, you must use the APPLCTN, DATABASE, RTCODE, and TRANSACT macros, along with the batch system definition process, to create the resource definitions for these resources and store them in the IMS.MODBLKS data set. The following figure shows the control block generation process:

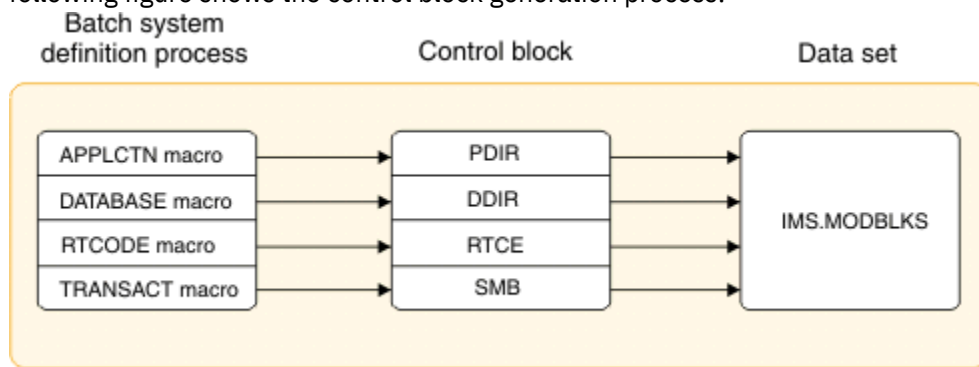

Figure 4. Control block generation process for MODBLKS resources

With DRD enabled, the APPLCTN, DATABASE, RTCODE, and TRANSACT macros are optional. If you do not code these macros as part of the system definition process, you can either import resource definitions into IMS from a resource definition data set (RDDS) or an IMSRSC repository, or you can use type-2 commands to define resources to IMS dynamically (instead of using online change).

For IMS systems in which DRD is not enabled or unavailable, after IMS initialization, you use the online change process to add, change, and delete resource definitions dynamically. The online change process requires that you:

1. Generate the resource definitions and store them in an IMS.MODBLKS staging library data set
2. Run the Online Change Copy utility (DFSUOCU0) to copy the staging library into an inactive library
3. Run a series of online change commands to cause the change to take effect (see the figure below)

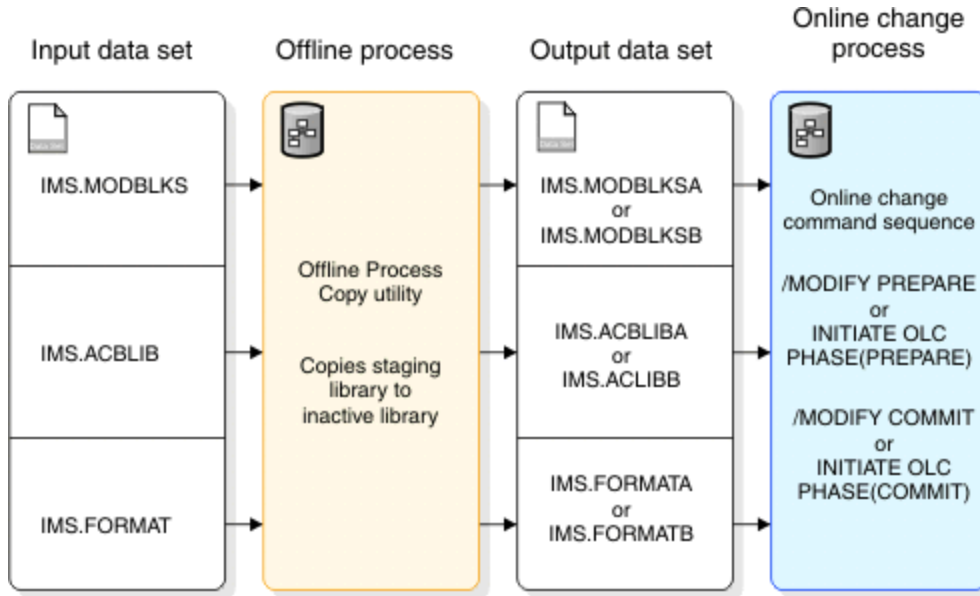

Figure 5. Online change process for IMS resources

Another aspect of the online change process is that, during the COMMIT phase, all the resources associated with the definitions in the IMS.MODBLKS data set are quiesced, which affects IMS availability.

Recommendation: Unless you have a simple system, and online change meets your requirements, use DRD with the repository or DRD with RDDs rather than the IMS.MODBLKS data set.

To change some resources online (for example, resources in IMS.ACBLIB), you cannot use DRD and must use the online change process.

MSC resources

For IMS systems in which DRD for MSC resources is not enabled or is unavailable, you must use the MSPLINK, MSLINK, MSNAME, and NAME macros, along with the batch system definition process, to create the resource definitions for these resources, and store them in the IMS.DFSCLL3x and IMS.DFSCLL data sets. The following figure shows the control block generation process for MSC resources.

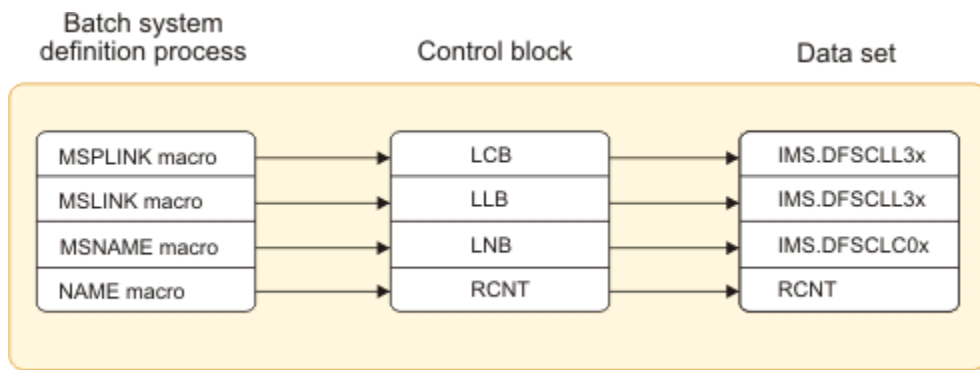

Figure 6. Control block generation process for MSC resources

With DRD enabled for MSC resources, the MSPLINK, MSLINK, MSNAME, and NAME macros are optional. If you do not code these macros as part of the system definition process, you can import resource definitions into IMS from the IMSRSC repository, or you can use type-2 commands to define resources to IMS dynamically.

Tip: If dynamic definition of MSC resources is enabled, you can use the IMSRSC repository to save the dynamically created resource definitions permanently, even across cold starts.

Related concepts

[“Exporting MODBLKS resource and descriptor definitions to an IMSRSC repository” on page 81](#)

You can export resource and descriptor definitions from IMS to an IMSRSC repository by using the automatic export function or by issuing the EXPORT DEFN TARGET(REPO) command. You can export resource and descriptor definitions from the IMS system to the repository and have them defined for one or more new or existing IMS systems in your IMSplex.

[“Overview of the IMSRSC repository” on page 37](#)

A repository is a generalized data storage facility that can be used to store any type of information. The IMS resource definition (IMSRSC) repository is a set of VSAM key sequenced data sets (KSDSs) used for storing information. The IMSRSC repository is a repository to store resource (and descriptor) definitions for IMS databases, transactions, programs, and routing codes. This repository is an alternative to the resource definition data set (RDDS) that is used with the dynamic resource definition (DRD) function.

[“Resource definition data sets” on page 158](#)

Resource definition data sets (RDDSs) contain resource definitions and resource descriptor definitions, which can be imported from or exported to IMS systems to define a standard set of attributes for resources.

[“IMSRSC repository and RS catalog repository data sets” on page 160](#)

The IMSRSC repository uses a set of VSAM key-sequenced data sets (KSDSs) that you define to store the resource and descriptor definitions for the members of an IMSplex in a common repository.

[The online change function \(System Administration\)](#)

[Modifying system resources online \(Operations and Automation\)](#)

Related tasks

[Enabling dynamic definition for MSC resources \(System Definition\)](#)

[“Importing MODBLKS resource and descriptor definitions by using the automatic import function” on page 85](#)

With dynamic resource definition (DRD) enabled, you can enable the automatic import function so that MODBLKS resource and descriptor definitions are imported to IMS during IMS cold start processing.

Managing resource and descriptor definitions

With dynamic resource definition (DRD) enabled, you can perform several tasks to manage the resource and descriptor definitions for your IMS system.

With DRD enabled, you can perform the following tasks:

- Create resources or descriptors
- Update resources or descriptors
- Delete resources or descriptors
- Query definitional attributes of resources or descriptors (by using the **QUERY** command)
- Export resource and descriptor definitions from IMS to a resource definition data set (RDDS) or an IMSRSC repository
- Import resource and descriptor definitions from an RDDS or a repository into IMS, which creates new resources and descriptors and updates existing resources and descriptors

With DRD, you can use the CREATE, IMPORT, UPDATE, and DELETE type-2 commands to dynamically create, update, and delete application program, database, routing code, and transaction resource and descriptor definitions.

With DRD, you can also CREATE, UPDATE, and DELETE MSC resources (LTERM, MSLINK, MSNAME, MSPLINK), but cannot IMPORT them. MSC resources do not support RDDS or EXPORT.

Note: MSC resources do not have descriptors.

Issue the type-2 commands from a single point of control (SPOC) application (for example, the TSO SPOC shipped with IMS). You can also use the IMS Manage Resources application that is available from the IMS Application Menu (option 2).

Resource descriptors are templates that can be used to define new resources and descriptors. IMS supplies four resource descriptors, one for each resource type. The descriptors contain IMS-system default values for each resource attribute. These IMS-supplied descriptors cannot be deleted or modified. IMS-supplied descriptors are not exported to the repository or RDDS. The four IMS-supplied resource descriptors are:

- DFSDSDB1 (database descriptor)
- DFSDSPG1 (application program descriptor)
- DBFDSRT1 (Fast Path routing code descriptor)
- DFSDSTR1 (transaction descriptor)

You can use the IMS-supplied descriptors as models for creating resources or additional descriptors. You can also create descriptors without modeling them after existing descriptors. Initially, the IMS-supplied descriptors are set as the default descriptors, but you can designate one of your own descriptors as the default by using the DEFAULT(Y) keyword on the CREATE or UPDATE command.

When you create a resource without specifying a model (that is, you do not specify the LIKE keyword), any attribute values that are not specified on the CREATE command are inherited from the default descriptor. When you create a resource that is modeled from a descriptor (using the LIKE keyword), any attribute values that are not specified on the CREATE command are inherited from the descriptor.

Similarly, when you create a resource using an existing resource as a model (using the LIKE keyword), any attribute values that are not specified on the CREATE command are inherited from the existing resource.

Tip: To ease the transition from using the online change process to using DRD, you can create runtime resource definitions using the batch system definition process and then enable DRD so that you can use the DRD commands.

IMS systems can export resources that are defined by the batch system definition process and resource definitions that have been created or updated dynamically, to an RDDS or an IMSRSC repository, by using the **EXPORT DEFN** command. You can also set up your system for automatic export to an RDDS or an IMSRSC repository.

These resource definitions can then be imported from the RDDS into an IMS system during cold start processing. To ensure that your changes are recovered across a cold start: export all IMS definitions to an RDDS or repository before shutting it down. For RDDSs, you can also set up your system to automatically export your resource and descriptor definitions at checkpoint time. Set up your system to automatically import the definitions from the RDDS or repository during cold start processing.

In situations when IMS receives a message for an unknown destination, you can also use the Destination Creation exit routine (DFSINSX0) to define a new transaction to IMS for that message and, if necessary, define the application program that is associated with the transaction.



Attention: DRD changes are not necessarily made across all IMS systems in an IMSplex. Changes might be successful on some IMS systems but fail on others. You must verify that changes have been made across all systems.

The figure that follows shows the ISPF panel for managing resources.

```

Help
-----
SPOC                IMS Manage Resources

Command ==>

Select an action and press Enter.

* Action . . . . . 1. Create new resources
                   2. Delete resources
                   3. Query resources
                   4. Update resources
                   5. Import resources
                   6. Export resources
                   7. Manage RDDS

```

Figure 7. IMS Manage Resources main panel

Related concepts

[“Overview of the IMSRSC repository” on page 37](#)

A repository is a generalized data storage facility that can be used to store any type of information. The IMS resource definition (IMSRSC) repository is a set of VSAM key sequenced data sets (KSDSs) used for storing information. The IMSRSC repository is a repository to store resource (and descriptor) definitions for IMS databases, transactions, programs, and routing codes. This repository is an alternative to the resource definition data set (RDDS) that is used with the dynamic resource definition (DRD) function.

[“Creating runtime resource and descriptor definitions” on page 53](#)

When dynamic resource definition (DRD) is enabled, you can define runtime resources and descriptor definitions to IMS dynamically, eliminating the requirement to use the online change process or to cold start IMS.

Related tasks

[“Exporting resource and descriptor definitions” on page 79](#)

When resource and descriptor definitions are ready to be created in a resource definition data set (RDDS) or an IMSRSC repository as the stored resource and descriptor definitions, you can export them to the RDDS or the repository.

[“Importing resource and descriptor definitions” on page 84](#)

With dynamic resource definition (DRD) enabled, you can import resource and descriptor definitions from a resource definition data set (RDDS) or the IMSRSC repository by using the automatic import function or the **IMPORT** command.

Related reference

[IMS commands \(Commands\)](#)

Commands that support dynamic resource definition

With dynamic resource definition (DRD), you can use type-1 and type-2 commands to define resource and descriptor definitions.

The following IMS type-2 commands support DRD.

- CREATE DB
- CREATE DBDESC
- CREATE LTERM
- CREATE MSLINK
- CREATE MSNAME
- CREATE MSPLINK
- CREATE PGM
- CREATE PGMDESC
- CREATE RTC
- CREATE RTCDESC
- CREATE TRAN

CREATE TRANDESC
 DELETE DB
 DELETE DBDESC
 DELETE DEFN (supported for the IMSRSC repository only)
 DELETE LTERM
 DELETE MSLINK
 DELETE MSNAME
 DELETE MSPLINK
 DELETE PGM
 DELETE PGMDESC
 DELETE RTC
 DELETE RTCDESC
 DELETE TRAN
 DELETE TRANDESC
 EXPORT DEFN
 IMPORT DEFN
 QUERY DB
 QUERY DBDESC
 QUERY MEMBER
 QUERY PGM
 QUERY PGMDESC
 QUERY RTC
 QUERY RTCDESC
 QUERY TRAN
 QUERY TRANDESC
 UPDATE DB
 UPDATE DBDESC
 UPDATE MSLINK
 UPDATE MSNAME
 UPDATE MSPLINK
 UPDATE PGM
 UPDATE PGMDESC
 UPDATE RTC
 UPDATE RTCDESC
 UPDATE TRAN
 UPDATE TRANDESC

The following IMS type-1 commands support DRD:

- **/CHECKPOINT**

If automatic export is enabled, and one or more resource or descriptor definitions have been created, updated, or deleted since the last checkpoint, the **/CHECKPOINT** command causes changed resource and descriptor definitions with a status of EXPORTNEEDED to be written to the system resource definition data set (RDDS) that contains the oldest data, the IMSRSC repository, or both.

- **/CHECKPOINT DUMPQ|FREEZE|PURGE**

If automatic export is enabled, and one or more resource or descriptor definitions have been created, updated, or deleted since the last checkpoint, the **/CHECKPOINT DUMPQ|FREEZE|PURGE** command causes all resource and descriptor definitions to be written to the system RDDS that contains the oldest data, the IMSRSC repository, or both.

- **/MODIFY**

If DRD is enabled and MODBLKS is specified on the **/MODIFY** command, the command fails.

The X'22' log record represents an action that is generated by a type-2 command. It is written for most type-2 commands that are recoverable and for some type-2 commands, such as **QUEUE** and **UPDATE**, for diagnostic information. Refer to DFSLOG22 for mapping of the X'22' log record. For most commands, the X'22' log records indicate that the type-2 command is recoverable, and it is used to reprocess the command during a warm or emergency restart. The X'22' log record is also used to communicate the command changes to the XRF alternate system, the DBCTL warm standby system, or the FDBR system. For some commands, the X'22' log records are for diagnostics only and are not used to recover or reprocess the command.

For the transaction, program, routing code, and database resources and descriptors, the X'22' log record tracks the changes made to the runtime resource and descriptor definitions that result from the CREATE, UPDATE, DELETE, and IMPORT commands, and the MODBLKS online change procedure.

For the MSC remote LTERM, logical link (MSLINK), physical link (MSPLINK), and logical link path (MSNAME) resources, the X'22' log record tracks the changes made to the runtime resource definitions that result from the CREATE, UPDATE, and DELETE commands

The **EXPORT** command does not generate a X'22' log record.

In addition to being able to dynamically create, update, query, and delete runtime resource and descriptor definitions, with DRD you have other benefits, including:

- Type-2 command benefits, including the ability to sort, scroll, and use wildcards in the command.
- Returned command completion code text is displayed with a brief description of the completion code.
- All create, update, and delete activities are logged in the log record X'22', to aid in recovery after a warm or emergency restart.
- Create, update, access time stamps are maintained.

If DRD is not enabled for MODBLKS resources, you can use the following type-2 commands:

- QUERY DB
- QUERY IMS
- QUERY PGM
- QUERY RTC
- QUERY TRAN
- UPDATE DB START()
- UPDATE DB STOP()
- UPDATE IMS
- UPDATE PGM START()
- UPDATE PGM STOP()
- UPDATE RTC START()
- UPDATE RTC STOP()
- UPDATE TRAN SET(LOCK())
- UPDATE TRAN START()
- UPDATE TRAN STOP()

If DRD is not enabled for MSC resources, you can use the following type-2 commands:

- QUERY LTERM
- QUERY MSLINK
- QUERY MSNAME
- QUERY MSPLINK
- UPDATE MSLINK
- UPDATE MSNAME

- UPDATE MSPLINK

The **EXPORT** command can be issued in a non-DRD enabled IMS system. However, in a non-DRD enabled IMS system, the only RDDS that can be exported to is a non-system RDDS.

Related concepts

[“Overview of the IMSRSC repository” on page 37](#)

A repository is a generalized data storage facility that can be used to store any type of information. The IMS resource definition (IMSRSC) repository is a set of VSAM key sequenced data sets (KSDSs) used for storing information. The IMSRSC repository is a repository to store resource (and descriptor) definitions for IMS databases, transactions, programs, and routing codes. This repository is an alternative to the resource definition data set (RDDS) that is used with the dynamic resource definition (DRD) function.

Related reference

[IMS commands \(Commands\)](#)

Dynamic resource definition and system definition

Specify parameters related to dynamic resource definition (DRD) in the DFSDFxxx member of the IMS PROCLIB data set.

The DFSDFxxx member of the IMS PROCLIB data set contains parameters for the IMS Common Service Layer (CSL), shared queues, databases, restart exit routines, dynamic resource definition (DRD), the IMSRSC repository, dynamic database buffer pools, the Fast Path 64-bit buffer manager, and the IMS abend search and notification procedure.

The DFSDFxxx member includes some parameters that also exist in the DFSSQxxx member (for defining parameters related to shared queues) and the DFSCGxxx member (for defining parameters related to the CSL). If you specify these common parameters in the DFSDFxxx member, you do not have to specify them in the DFSSQxxx and DFSCGxxx members. Any attributes explicitly defined in the DFSSQxxx and DFSCGxxx members override the attributes defined in the DFSDFxxx member.

The MODBLKS= keyword enables either DRD (MODBLKS=DYN) or the online change process (MODBLKS=OLC). The MODBLKS= keyword can only be changed as part of a cold start. MODBLKS=OLC and MODBLKS=DYN are mutually exclusive. You can specify the MODBLKS= keyword in either the DFSCGxxx member, or in the CSL section of the DFSDFxxx member. If you specify a value for the MODBLKS= keyword in the DFSCGxxx member, that value overrides the value specified for the MODBLKS= keyword in the DFSDFxxx member.

If the online change process is disabled (DRD is enabled), the IMS, DBC, and DCC procedures no longer require the DD statements for the IMS.MODBLKS data sets, IMS.MODBLKSA and IMS.MODBLKSB.

The DFSDFxxx member of the IMS PROCLIB data set contains the MSC section, which specifies options for the Multiple Systems Coupling function, including DRD support.

Related concepts

[“Overview of the IMSRSC repository” on page 37](#)

A repository is a generalized data storage facility that can be used to store any type of information. The IMS resource definition (IMSRSC) repository is a set of VSAM key sequenced data sets (KSDSs) used for storing information. The IMSRSC repository is a repository to store resource (and descriptor) definitions for IMS databases, transactions, programs, and routing codes. This repository is an alternative to the resource definition data set (RDDS) that is used with the dynamic resource definition (DRD) function.

Related reference

[“DFSDFxxx member of the IMS PROCLIB data set” on page 756](#)

The DFSDFxxx member of the IMS PROCLIB data set consolidates the specification of processing options for many different IMS components and functions.

Recovery of changed runtime resource and descriptor definitions

Changes that are made to resource and descriptor definitions by using type-2 commands are logged and recoverable across a warm or emergency restart.

The runtime resource and descriptor definitions are restored from the logs during restart processing. Existing runtime resource and descriptor definitions might also be updated during warm or emergency restart if definitional changes were made in the IMSRSC repository while the IMS system was down. IMS uses *change lists* to preserve the changes across a warm or emergency restart.

One of the external data sources in which resource and descriptor definitions are stored is a BSAM data set called a *resource definition data set* (RDDS). The definitions in an RDDS are in a binary format. RDDSs are not supported for MSC resources or in IMS FDBR regions.

Another of the external data sources in which resource and descriptor definitions are stored is the IMSRSC repository. The repository is not supported in IMS FDBR regions.

For changes to be recoverable across a cold start (applicable only to non-MSC resources), the changed resource and descriptor definitions must be exported to, or stored in, a repository or a resource definition data set (RDDS) before IMS terminates, and imported into IMS either:

- During cold start with the automatic import function.
- After IMS is up and running with the **IMPORT** command.

Alternatively, you can do the following tasks:

1. Update your IMS system definition macros.
2. Perform a system generation.
3. Cold start IMS.
4. Import the resource definitions from the IMS MODBLKS data set.

Related concepts

[“Overview of the IMSRSC repository” on page 37](#)

A repository is a generalized data storage facility that can be used to store any type of information. The IMS resource definition (IMSRSC) repository is a set of VSAM key sequenced data sets (KSDSs) used for storing information. The IMSRSC repository is a repository to store resource (and descriptor) definitions for IMS databases, transactions, programs, and routing codes. This repository is an alternative to the resource definition data set (RDDS) that is used with the dynamic resource definition (DRD) function.

[Recovery during the IMSRSC repository data set update process \(Operations and Automation\)](#)

[“Restrictions for dynamic resource definition” on page 45](#)

If you plan to use dynamic resource definition (DRD) in your IMS system, some restrictions apply to your use of DRD.

Overview of the IMSRSC repository

A repository is a generalized data storage facility that can be used to store any type of information. The IMS resource definition (IMSRSC) repository is a set of VSAM key sequenced data sets (KSDSs) used for storing information. The IMSRSC repository is a repository to store resource (and descriptor) definitions for IMS databases, transactions, programs, and routing codes. This repository is an alternative to the resource definition data set (RDDS) that is used with the dynamic resource definition (DRD) function.

An RDDS stores the resource and descriptor definitions for one local IMS only, and two or more system RDDS data sets must be defined for each local IMS. The repository provides the ability for an IMSplex to use a single shared repository to store resource and descriptor definitions for all the members of an IMSplex.

A repository can maintain resource and descriptor definitions for up to 64 IMS systems in an IMSplex.

The repository is managed by the Repository Server (RS) address space. RS is in turn managed by the Common Service Layer (CSL) Resource Manager (RM). Resource and descriptor definitions can be added, queried, modified, or deleted from the repository by making requests to RM using type-2 commands.

The repository can store the resource and descriptor definitions that are supported by DRD. IMS can retrieve the stored definitions to dynamically generate runtime resources and descriptors. The resource and descriptor definitions that can be stored in the repository are:

- Application programs
- Databases
- Fast Path routing codes
- Transactions

The following Multiple Systems Coupling (MSC) resource definitions can also be stored in the repository:

- MSC physical and logical links
- MSC logical link paths
- Remote logical terminals (LTERMs)

The following components work together to provide the overall IMS repository function:

- IMS, with a CSL consisting of an Operations Manager (OM), an RM, and a Structured Call Interface (SCI).
- RS, which is a BPE-based address space.
- Two or three pairs of data sets for the IMSRSC repository data sets.
- Two pairs of data sets for the RS catalog repository data sets.
- A single point of control (SPOC) or automation application program.
- Optionally, a Common Queue Server (CQS) address space and a coupling facility with an RM resource structure.

The RM resource structure, if used, contains the repository name and repository type. This information is written by the first RM to connect to a repository. Subsequent RMs use the information in the resource structure to connect to the repository.

The following illustration shows the relationship of the repository components.

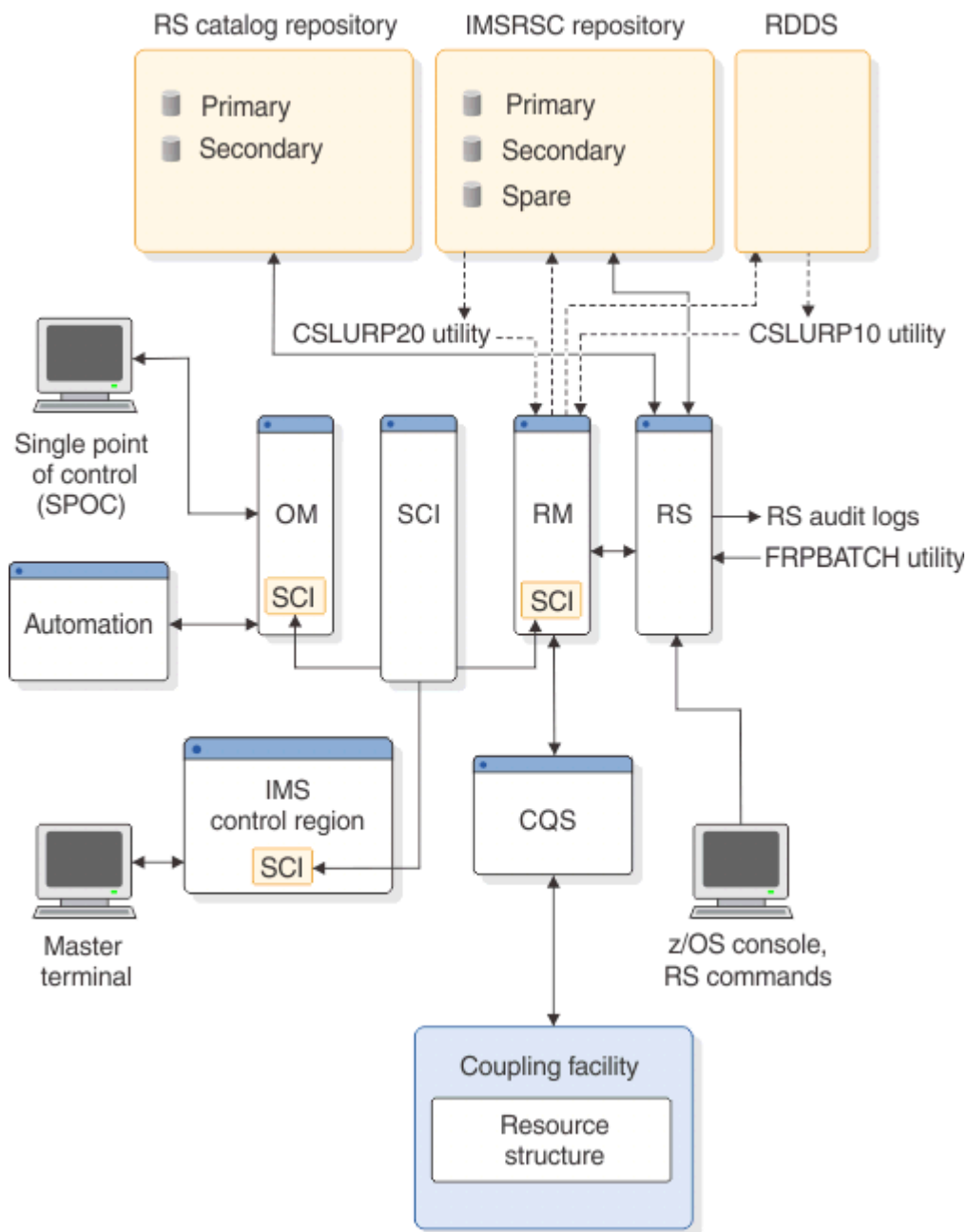

The RS is a started task running under z/OS in a sysplex environment. The RS must be running to provide the following functions:

1. Interface with the client (RM or FRPBATCH utilities) using z/OS cross-system coupling facility
2. Communication with the RS catalog repository data sets and management of one or more IMSRSC repository data sets
3. Management of server registrations and repository connections
4. Audit logging and trace facilities
5. Repository data integrity
6. Data compression and decompression

At any time, there is a single active or master RS address space. The RS can run on any logical partition (LPAR) in the sysplex where an IMSplex is running. It does not have to be on the same LPAR as any other IMS address space.

If there are multiple RS address spaces in the sysplex, one of them is considered the master and the others are subordinates. One master RS can manage all the repositories in the sysplex or there can be one master RS for each IMSplex.

One or more subordinate RS address spaces can also be started. The subordinate RSs wait in an initialization state. When the subordinate RSs identify that the master RS has terminated, they all attempt to complete the startup process. One subordinate RS becomes the new master. The others remain as subordinate RSs.

Recommendation: Use one master RS per IMSplex to achieve maximum availability and storage efficiency.

All requests for online work associated with the stored definitions flows from IMS to RS through RM. IMS also provides RM utilities that can perform work with the repository offline.

The RS address space has the following administrative interfaces: JCL batch (FRPBATCH) and z/OS MODIFY (F) command.

Related concepts

[“Overview of dynamic resource definition” on page 29](#)

With dynamic resource definition (DRD), you can use type-2 commands to define MODBLKS resources such as application programs, databases, routing codes, and transactions, and resource descriptors, and MSC resources such as definitions for MSC physical links, logical links, logical link paths, and remote logical terminals.

IMS ID information in the IMSRSC repository

When resource definitions are *added* to the IMSRSC repository, along with the resource definitions and the IMS resource lists, the IMS ID information is also maintained in the IMSID member table. This table keeps track of all the IMS IDs that are defined to the IMSRSC repository.

When the resource definitions are *deleted* from the IMSRSC repository, the IMS ID information is still in the IMS ID member table. When a subsequent **EXPORT DEFN TARGET(REPO) SET(IMSID(*))** is issued or autoexport is done when **AUTOEXPORT_IMSID=ALL** is issued, the resource definitions are written for all the IMS IDs in the member table.

When an IMS is leaving the IMSplex or when an IMS ID is added to the IMSRSC repository in error, the IMS ID information can be deleted from the IMSRSC repository using the **DELETE DEFN TARGET(REPO) TYPE(IMSIDMBR)** command.

Defining the IMSRSC repository

Before you can use the IMSRSC repository to store and retrieve resource and descriptor definitions, you must define it. In addition, IMS and the Resource Manager (RM) must have the repository enabled, the Repository Server (RS) must be started and active, and the repository must be started.

About this task

To define the repository, define the Repository Server (RS) catalog repository data sets, start the RS, and perform system definition of the repository so it is available for RM and IMS.

The following is a checklist of tasks to perform to define the repository after installing and verifying the installation of IMS.

To define the repository:

Procedure

1. Allocate the RS catalog repository data sets and the IMSRSC repository data sets.
See [“IMSRSC repository and RS catalog repository data sets” on page 160](#).
2. Define the Base Primitive Environment (BPE) parameters in the BPE configuration member of the IMS PROCLIB data set.

- See [“BPE configuration parameter member of the IMS PROCLIB data set”](#) on page 665.
3. Specify values for the RS in the FRPCFG member of the IMS PROCLIB data set.
See [“FRPCFG member of the IMS PROCLIB data set”](#) on page 911.
 4. Define security settings to restrict access to the repository.
See [Restricting access to the RS catalog repository and IMSRSC repository \(System Administration\)](#).
 5. Start the RS.
See [Starting the Repository Server \(Operations and Automation\)](#).
 6. Start the subordinate RSs.
See [Starting subordinate Repository Servers \(Operations and Automation\)](#).
 7. Issue the **ADD** and **START** FRPBATCH commands to add the repository to the RS catalog repository data sets and to start the repository.
See [ADD command for FRPBATCH \(System Programming APIs\)](#) and [START command for FRPBATCH \(System Programming APIs\)](#).
 8. Define the repository to the Resource Manager (RM) by using the CSLRIxxx member of the IMS PROCLIB data set.
See [“CSLRIxxx member of the IMS PROCLIB data set”](#) on page 719.
 9. Restart RM or issue the **UPDATE RM** command so that RM can use the repository. See [Restarting the CSL RM \(Operations and Automation\)](#) and [UPDATE RM command \(Commands\)](#).
 10. Specify values for the repository in the REPOSITORY section of the DFSDFxxx member of the IMS PROCLIB data set.
See [“REPOSITORY section of the DFSDFxxx member”](#) on page 805.
 11. Define automatic import and automatic export options by updating the DYNAMIC_RESOURCES section of the DFSDFxxx member of the IMS PROCLIB data set.
See [“DYNAMIC_RESOURCES section of the DFSDFxxx member”](#) on page 780.
 12. Restart IMS or issue the **UPDATE IMS** command to enable the repository at the IMS.
See [Restarting IMS \(Operations and Automation\)](#) and [UPDATE IMS command \(Commands\)](#).

Results

You can use the Syntax Checker to verify the repository system definition changes.

Related concepts

[“IMS Syntax Checker”](#) on page 381

The Syntax Checker is an ISPF application that helps you define, verify, and validate parameters and their values in the members of the IMS PROCLIB data set. Use the IMS Syntax Checker to avoid typographical and syntactical errors when modifying the parameter values for the IMS PROCLIB data set members.

[CSL RM management of the IMSRSC repository \(System Administration\)](#)

[IMSRSC repository administration \(System Administration\)](#)

[“IMSRSC repository and RS catalog repository data sets”](#) on page 160

The IMSRSC repository uses a set of VSAM key-sequenced data sets (KSDSs) that you define to store the resource and descriptor definitions for the members of an IMSplex in a common repository.

[Dynamic resource definition sample application with the IMSRSC repository \(Installation\)](#)

Related tasks

[“Enabling dynamic definition for MODBLKS resources with an IMSRSC repository”](#) on page 51

After performing the initial verification of your IMS environment, you can enable dynamic resource definition (DRD) for MODBLKS resources with an IMSRSC repository.

[Starting the Repository Server \(Operations and Automation\)](#)

Related reference

[“REPOSITORY section of the DFSDFxxx member”](#) on page 805

The REPOSITORY section of the DFSDFxxx member specifies the repository types that are to be enabled at IMS. The valid type is: IMSRSC repository, which is used to store the stored resource definitions for

DRD resources. The section must begin with the header <SECTION=REPOSITORY>. The REPOSITORY section is valid in DB/DC, DBCTL, and DCCTL environments.

“DYNAMIC_RESOURCES section of the DFSDFxxx member” on page 780

The DYNAMIC_RESOURCES section of the DFSDFxxx member specifies options for import and export, log write ahead, and system resource definition data sets. This section is processed only if DRD is enabled (MODBLKS=DYN). If DRD is not enabled, this section is ignored. The section is defined by the header <SECTION=DYNAMIC_RESOURCES>. The DYNAMIC_RESOURCES section is valid in DB/DC, DBCTL, and DCCTL environments.

“CSLRIxxx member of the IMS PROCLIB data set” on page 719

Use the CSLRIxxx member of the IMS PROCLIB data set to specify parameters that initialize RM.

“FRPCFG member of the IMS PROCLIB data set” on page 911

Use the FRPCFG member of the IMS PROCLIB data set to define the Repository Server (RS) configuration parameters relating to performance, communications, and security. FRPCFG also identifies the names of the RS catalog repository data sets.

“BPE configuration parameter member of the IMS PROCLIB data set” on page 665

Use the BPE configuration parameter member of the IMS PROCLIB data set to define BPE execution environment settings such as tracing, language, and statistics time interval settings for an address space that is being started.

Resource lists for the IMSRSC repository

In addition to stored resource definitions and resource descriptors, the IMSRSC repository also contains resource lists.

A *resource list* is a list of resource and descriptor names and types that are defined for an IMS system.

The EXPORT DEFN TARGET(REPO) command can define the IMS systems for which the resource definitions must be defined by using the SET(IMSID()) keyword. The resource definitions exported from one IMS system to the repository can be defined as applicable to all IMS systems in the IMSplex or to a given set of IMS systems.

An IMS resource list can be created or updated in the IMSRSC repository when you issue an EXPORT DEFN TARGET(REPO) command with SET(IMSID(imsidlist)) or the EXPORT DEFN TARGET(REPO) with the SET(IMSID()) omitted. The EXPORT will also write the resource definitions to the repository. The IMS resource list contains all of the resource names and types owned by an IMS system. There is one IMS resource list per IMS for each resource type in the repository.

If an EXPORT DEFN TARGET(REPO) SET(IMSID(IIMS1,IMS2,IMS3)) is issued, an IMS resource list is created for each IMSids IMS1, IMS2, IMS3 if the IMS resource lists for the IMSids do not exist. If you skip the SET(IMSID()) keyword, the IMSid defaults to the command master IMS and the IMS resource list is created for the command master IMSid if one does not exist.

A resource list is used during an IMS cold start to identify all the resource and descriptor definitions that are to be imported during the cold start. If the IMS resource list does not exist, all the resource names and resource types being exported are added to the newly created IMS resource list. If the IMS resource list exists, newly created resource names and resource types are updated in the existing IMS resource list. The resource list is also used during IMPORT DEFN command processing to identify resources that can be imported by an IMS.

When you issue the EXPORT command with SET(IMSID(*)) all the existing IMS resource lists in the repository are updated with any new resource names and resource types being added. If you issue the very first EXPORT command with SET(IMSID(*)) when the IMSRSC repository is empty it will fail.

You can also check the contents of the repository issuing QUERY DB | DBDESC | PGM | PGMDESC RTC | RTCDESC | TRAN | TRANDESC commands with SHOW(DEFN,GLOBAL) or SHOW(IMSID). If the repository is empty and has no resource definitions the QUERY command will fail.

The IMS QUERY SHOW(IMSID) commands can retrieve the information from the IMS resource lists. The command output returns the list of resource names in each IMS resource list.

Related tasks

[Cold starting an IMS system that uses the IMSRSC repository \(Operations and Automation\)](#)

[“Importing resource and descriptor definitions” on page 84](#)

With dynamic resource definition (DRD) enabled, you can import resource and descriptor definitions from a resource definition data set (RDDS) or the IMSRSC repository by using the automatic import function or the **IMPORT** command.

[“Exporting resource and descriptor definitions” on page 79](#)

When resource and descriptor definitions are ready to be created in a resource definition data set (RDDS) or an IMSRSC repository as the stored resource and descriptor definitions, you can export them to the RDDS or the repository.

Related reference

[QUERY commands \(Commands\)](#)

[EXPORT command \(Commands\)](#)

[RDDS to Repository utility \(CSLURP10\) \(System Utilities\)](#)

[DELETE DEFN command \(Commands\)](#)

Change lists for the IMSRSC repository

IMS warm or emergency restart processes the IMS log to build runtime resource definitions. After the log is processed, if IMS is enabled to use the IMSRSC repository, IMS calls Resource Manager (RM) to read any change list for the IMS.

When you issue the **IMPORT DEFN SOURCE(REPO)** command, you can specify whether the import is applicable to:

- All IMS systems in which the resource is defined (even if some of the IMS systems are not active), or
- All active IMS systems in the IMSplex

The keywords **SCOPE(ALL)** and **SCOPE(ACTIVE)** for the **IMPORT DEFN** command identify whether the command applies to all IMS systems in which the resource is defined or only to the active systems.

If stored resource definitions are imported by an **IMPORT DEFN SCOPE(ALL)** command and an IMS system for which the resource definitions are defined is not active, a change list is created by the RM for that IMS in the repository. A change list consists of resource and descriptor names and types that are to be imported when the IMS system restarts.

If IMS is enabled to use the repository, IMS calls Resource Manager (RM) during warm start or emergency start to read any change list for the IMS. If a change list exists for the IMS that is being restarted, the database, program, transaction, and routing code resources and descriptors in the IMS change list and that apply to the IMS environment are quiesced and are not available for use until the stored resource definitions are imported from the repository. After the IMS log is processed, IMS imports the stored resource definitions from the repository for the database, program, transaction, and routing code resources and descriptors in the IMS change list. It then applies the changes to the runtime resource and descriptor definitions in the IMS. For the resources or descriptors that are in the IMS change list and that do not exist in IMS, the runtime resource definitions are created from the stored resource definitions in the repository. For the resource or descriptors that exist in IMS, the runtime resource definitions are updated with the stored resource definitions from the repository. The change list for the IMS system is deleted at the end of the cold, warm, or emergency restart.

Related concepts

[Emergency restarts and dynamic resource definition \(Operations and Automation\)](#)

Related tasks

[“Importing resource and descriptor definitions” on page 84](#)

With dynamic resource definition (DRD) enabled, you can import resource and descriptor definitions from a resource definition data set (RDDS) or the IMSRSC repository by using the automatic import function or the **IMPORT** command.

[“Exporting resource and descriptor definitions” on page 79](#)

When resource and descriptor definitions are ready to be created in a resource definition data set (RDDS) or an IMSRSC repository as the stored resource and descriptor definitions, you can export them to the RDDS or the repository.

[Warm starting IMS \(or normal restart\) \(Operations and Automation\)](#)

[Changing databases dynamically in online systems \(Database Administration\)](#)

[Introducing databases into online systems \(Database Administration\)](#)

XRF considerations for IMS change list processing

The IMS change list is created for an XRF alternate IMS during the **IMPORT DEFN SOURCE(REPO) SCOPE(ALL)** command if the resource definition is defined for the XRF alternate system.

When the XRF alternate is in restart mode, it is considered inactive. The IMS change list that is created for the XRF alternate is deleted during takeover without being processed, because the resource definitions are created or updated on the alternate from the log records that are sent from the IMS active system.

If one exists, the IMS change list for the IMS active system is processed during the restart of the IMS active system, and the X'22' log record that was written during the internal import is processed on the XRF alternate to obtain the resource definitions. The IMS change list is ignored and deleted during takeover.

The IMS change list for the XRF alternate is not reprocessed at IMS takeover because all the information in the change list is already processed as a part of the X'22' log record and the checkpoint log records. The IMS change list for the XRF alternate is deleted at the end of takeover.

Requirements for dynamic resource definition

To use dynamic resource definition (DRD), you must define a Common Service Layer (CSL) with at least Structured Call Interface (SCI) and Operations Manager (OM). If the IMSRSC repository is used, a Resource Manager (RM) is required.

You must also ensure that your system has a type-2 command interface, such as the TSO SPOC application, the Manage Resources application, or another application that interacts with the OM API.

Define one or more resource definition data sets (RDDSs) or an IMSRSC repository in which to save your dynamically defined MODBLKS resource definitions. To save your dynamically defined MSC resource definitions, define and use an IMSRSC repository.

If the IMSRSC repository is used to store resource definitions, DRD requires:

- A CSL that contains SCI, OM, and RM.
- A Repository Server (RS) address space.
- IMSRSC repository data sets and RS catalog repository data sets defined to the RS address space.
- A type-2 command interface such as the TSO SPOC or other OM interface, for DRD commands.

If RDDSs are used to store MODBLKS resource definitions, DRD requires:

- A CSL that contains SCI and OM.
- One or more RDDSs.
- A type-2 command interface such as the TSO SPOC or other OM interface, for DRD commands.

The INITMOD procedure requires that you define either MODBLKSA or MODBLKSB to initialize the MODSTAT data set, even for an IMS that does not define the MODBLKS data set.

In a DRD for MODBLKS resources environment, the MODBLKS staging, active, and inactive data sets are no longer required. However, the Global Online Change utility (DFSUOLC0) requires that you define either MDBS=A or MDBS=B to initialize the OLCSTAT data set, even for an IMS that does not define the MODBLKS data set.

Related concepts

[“Overview of the IMSRSC repository” on page 37](#)

A repository is a generalized data storage facility that can be used to store any type of information. The IMS resource definition (IMSRSC) repository is a set of VSAM key sequenced data sets (KSDSs) used for storing information. The IMSRSC repository is a repository to store resource (and descriptor) definitions for IMS databases, transactions, programs, and routing codes. This repository is an alternative to the resource definition data set (RDDS) that is used with the dynamic resource definition (DRD) function.

[“IMSRSC repository and RS catalog repository data sets” on page 160](#)

The IMSRSC repository uses a set of VSAM key-sequenced data sets (KSDSs) that you define to store the resource and descriptor definitions for the members of an IMSplex in a common repository.

Restrictions for dynamic resource definition

If you plan to use dynamic resource definition (DRD) in your IMS system, some restrictions apply to your use of DRD.

The following restrictions apply to DRD:

- When DRD for MODBLKS resources is enabled, you cannot perform online change for the resources that are typically defined in the IMS.MODBLKS data set. If you have a simple system, such as a single IMS, and online change meets your requirements, consider continuing to use online change and not enabling DRD.
- In an IMSplex with only one IMS and DRD enabled, the /MODIFY PREPARE MODBLKS and INITIATE OLC PHASE(PREPARE) TYPE(MODBLKS) commands are rejected. The commands /MODIFY PREPARE ALL and INITIATE OLC PHASE(PREPARE) ALL do not apply to the IMS.MODBLKS data set.
- When DRD for MODBLKS and MSC resources is disabled, CREATE, DELETE, IMPORT, and most UPDATE commands that change the definitional attributes of a resource are rejected.

The following restrictions apply to DRD:

- You cannot delete IMS-defined internal MSNAMEs, which are MSNAMEs that begin with DFSM, MSNI or MSNS.
- You cannot delete an IMS-defined shared queues MSNAME that was dynamically created on this back-end IMS because of a CREATE MSNAME command on another IMS in the shared queues group. This MSNAME has a status of SHAREDQ.
- The following parameters for the UPDATE TRAN command are permitted whether or not DRD is enabled:
 - CLASS(class)
 - CPRI(value)
 - LCT(value)
 - LPRI(value)
 - MAXRGN(number)
 - MSNAME(name)
 - NPRI(value)
 - PARLIM(value)
 - PLCT(value)
 - PLCTTIME(value)
 - SEGNO(number)
 - SEGSZ(size)
 - TRANSTAT(Y | N)
- You cannot delete an IMS-supplied descriptor. The only attribute you can update on an IMS-supplied descriptor is the DEFAULT attribute.

- Because of the default Operations Manager (OM) routing in a sysplex, DRD commands are routed to all the IMS systems, unless you specify otherwise. However, the commands are not coordinated across the sysplex, so a command can succeed on some IMS systems and fail on others.
- The Multiple Systems Verification utility (DFSUMSV0) can verify resources defined only by the batch system definition process; it cannot verify resources that were created using DRD. Use the /MSVERIFY command to verify resources that are created dynamically.
- You can update a resource or a descriptor definition, but the changes to that resource or descriptor definition are not propagated to the resource or descriptor definitions that were built from the updated resource or descriptor definition.
- You can import a resource or descriptor from a resource definition data set (RDDS) or the IMSRSC repository and it affects any resource or descriptor explicitly specified in the IMPORT DEFN command, but it does not affect any resources or descriptors built from the specified resource or descriptor.
- DRD commands can be issued only through the OM API.
- DRD commands that work on database resources and descriptors cannot be issued in a DCCTL environment.
- DRD commands that work on transactions and routing code resources and descriptors cannot be issued in a DBCTL environment.
- None of the commands that support DRD can be issued on XRF alternate systems or FDBR regions.
- DELETE DB and UPDATE DB commands are rejected for MSDBs.

Related concepts

[“Overview of the IMSRSC repository” on page 37](#)

A repository is a generalized data storage facility that can be used to store any type of information. The IMS resource definition (IMSRSC) repository is a set of VSAM key sequenced data sets (KSDSs) used for storing information. The IMSRSC repository is a repository to store resource (and descriptor) definitions for IMS databases, transactions, programs, and routing codes. This repository is an alternative to the resource definition data set (RDDS) that is used with the dynamic resource definition (DRD) function.

[“Recovery of changed runtime resource and descriptor definitions” on page 37](#)

Changes that are made to resource and descriptor definitions by using type-2 commands are logged and recoverable across a warm or emergency restart.

[Recovery during the IMSRSC repository data set update process \(Operations and Automation\)](#)

Related reference

[IMS commands \(Commands\)](#)

[“Members of the IMS PROCLIB data set” on page 665](#)

These topics describe the IMS PROCLIB data set members that can be used in an IMS environment.

Considerations for using dynamic resource definition

To ensure that your use of dynamic resource definition (DRD) is successful, be aware of these usage considerations.

In addition to the requirements and restrictions that are associated with using DRD, consider the following issues:

- Before enabling dynamic resource definition or shared queues, evaluate any existing DFSINSX0 exit routines. The DFSINSX0 exit might need to be changed so that it checks whether LTERM creation is allowed before it accesses the USEQDATA parameter list that is related to LTERM processing. If LTERM creation is not allowed, the USEQDATA buffer address (INSXAUSQ) is zero.
- In an IMSplex with multiple IMS systems, some having DRD enabled, the command **INITIATE OLC PHASE(PREPARE) TYPE(MODBLKS)** is allowed so that the IMS systems that do not have DRD enabled can perform online change processes.
- The online change process is enabled and DRD is not enabled when:
 - MODBLKS=OLC is specified in the DFSCGxxx member of the IMS PROCLIB data set

- MODBLKS=OLC is specified in the COMMON_SERVICE_LAYER section of the DFSDFxxx member of the IMS PROCLIB data set
- A value is not specified for the MODBLKS= keyword in either member.
- In a shared EMH queues environment, a CREATE PGM command creates the application program, even if there are messages on the shared EMH queues for the application program. If the messages are placed on the shared EMH queues because the program was defined as Fast Path on another IMS, but this program is being created as non-Fast-Path on this IMS, this IMS is unable to access the messages on the shared EMH queues.
- If you are using the IMSRSC repository in an Extended Recovery Facility (XRF) environment, both the active IMS and alternate IMS must have the same definitions for using the repository.

The active IMS reads the resource definitions from the repository during cold start if AUTOIMPORT=AUTO or AUTOIMPORT=REPO is specified in the DFSDFxxx member of the IMS PROCLIB data set. The alternate IMS obtains its runtime definitions from the checkpoint log record of the active IMS. After takeover, the alternate IMS can export to, and import, delete or query from the repository. The UPDATE IMS command is processed, both at the active IMS and alternate IMS, to dynamically change the usage of the repository.

In an XRF environment, if the active IMS is enabled with the repository, the alternate IMS must also be enabled with the repository. Resource definitions for both the XRF active and the XRF alternate must be maintained in the repository. Issue the **EXPORT DEFN TARGET (REPO)** command with the SET(IMSID()) keyword to specify the IMS IDs of both the active and the alternate systems. Use this process so that the resource definitions can be defined or modified in the repository for both the active and alternate at the same time. Alternately, the **EXPORT DEFN TARGET (REPO)** command can be issued for the active system only and another **EXPORT DEFN TARGET (REPO)** command be issued on the alternate after a takeover. However, in this scenario, if the alternate must be cold-started as the new active before the **EXPORT** command is issued, any resource definition changes made by the old active system in the repository are not available for the new active system. Issue the **DELETE DEFN TARGET (REPO)** command with the FOR(IMSID()) keyword to specify the IMS IDs of both the active and the alternate systems. If this is not done, the resource definition becomes available at the next cold start or during an **IMPORT** command for the IMS that it is not deleted from.

- If you are using the repository in a DBCTL warm standby system, both the active DBCTL and warm-standby DBCTL must have the same definitions for using the repository.

The warm-standby DBCTL registers to RM during its initialization and connects to the repository.

During emergency restart command processing on the warm-standby DBCTL, any IMS change lists are read from the repository.

- All the DRD commands that work on application program resources and descriptors can be issued in DB/DC, DBCTL, and DCCTL environments.
- The MODBLKS DD statement is not required for MODBLKS=OLC or MODBLKS=DRD in an FDBR system.
- If you are not running with DRD enabled, any changes you make to the MODBLKS resources (database, transactions, programs, and routing codes) by using the type-1 commands persist across a warm or emergency restart, but they do not persist across a cold start. In a non-DRD environment, the control blocks that are used to manage the resources (DDIRs, PDIRs, SMBs, and RCTEs) are loaded from the MODBLKS data set at cold start. If a type-1 command is issued to change the attribute of a resource (such as the database access type or the transaction class), the internal control blocks are updated and the changes are recovered across a warm or emergency restart. If you perform a cold start, however, the control blocks are reloaded from the MODBLKS data set, and, unless you have updated your MODBLKS data set, the updated attributes revert to the original values.

If you are running with DRD enabled, any changes you make by using the type-1 or type-2 commands persist across a warm or emergency restart. They also persist across a cold start if the updated resource definitions are exported to either an RDDS or the repository, and then imported from the RDDS or repository during cold start. When you export the resource definitions to an RDDS or the repository, you export all the current attribute values. If you have changed the value of one of the attributes by using a type-1 or type-2 command (such as the database access type or the transaction class), the

updated attribute is exported. The updated attribute values are then imported during cold start if you have automatic import enabled.

- During a cold start, the partition status or access state is copied from the HALDB master. If you export the HALDB master status to the RDDS or the repository, the status of the master and its partitions is obtained from the RDDS or the repository.

Related concepts

[“Overview of the IMSRSC repository” on page 37](#)

A repository is a generalized data storage facility that can be used to store any type of information. The IMS resource definition (IMSRSC) repository is a set of VSAM key sequenced data sets (KSDSs) used for storing information. The IMSRSC repository is a repository to store resource (and descriptor) definitions for IMS databases, transactions, programs, and routing codes. This repository is an alternative to the resource definition data set (RDDS) that is used with the dynamic resource definition (DRD) function.

Related tasks

[“Exporting resource and descriptor definitions” on page 79](#)

When resource and descriptor definitions are ready to be created in a resource definition data set (RDDS) or an IMSRSC repository as the stored resource and descriptor definitions, you can export them to the RDDS or the repository.

[“Importing resource and descriptor definitions” on page 84](#)

With dynamic resource definition (DRD) enabled, you can import resource and descriptor definitions from a resource definition data set (RDDS) or the IMSRSC repository by using the automatic import function or the **IMPORT** command.

Related reference

[UPDATE commands \(Commands\)](#)

[/ERESTART command \(Commands\)](#)

Enabling dynamic definition for IMS resource groups

Before you can dynamically add, change, or delete a particular type of IMS resource, you must first enable dynamic resource definition for the resource group that includes the resource type.

About this task

You can enable dynamic definition for the following groups of IMS resources:

- MODBLKS resources, which include definitions for certain runtime attributes of application programs, databases, Fast Path routing codes, and transactions.
- MSC resources, which include definitions for MSC physical links, logical links, logical link paths, and remote terminals.

Restriction: Dynamically defined MSC resources cannot be used with an RDDS.

Requirement: The dynamic definition of IMS resources requires the Common Service Layer (CSL) with at least the Structured Call Interface (SCI) and the Operations Manager (OM).

The CSL can be enabled by parameters in either of the following members of the IMS PROCLIB data set:

- The DFSDFxxx member, in the COMMON_SERVICE_LAYER section.
- The DFSCGxxx member. The CSL values in the DFSCGxxx member override the values in the COMMON_SERVICE_LAYER section of the DFSDFxxx member.

Related concepts

[“Overview of the IMSRSC repository” on page 37](#)

A repository is a generalized data storage facility that can be used to store any type of information. The IMS resource definition (IMSRSC) repository is a set of VSAM key sequenced data sets (KSDSs) used for storing information. The IMSRSC repository is a repository to store resource (and descriptor) definitions for IMS databases, transactions, programs, and routing codes. This repository is an alternative to the resource definition data set (RDDS) that is used with the dynamic resource definition (DRD) function.

Related reference

[“COMMON_SERVICE_LAYER section of the DFSDfxxx member” on page 762](#)

The COMMON_SERVICE_LAYER section of the DFSDfxxx member of the IMS PROCLIB data set specifies options for the Common Service Layer (CSL), such as IMSplex name, ACB sharing, global online change, command authorization checking, OLCSTAT, DRD, and global resource status. The section is defined by the header <SECTION=COMMON_SERVICE_LAYER>. The COMMON_SERVICE_LAYER section is valid in DB/DC, DBCTL, and DCCTL environments.

[“DFSCGxxx member of the IMS PROCLIB data set” on page 728](#)

Use the DFSCGxxx member of the IMS PROCLIB data set to specify parameters that are related to the Common Service Layer (CSL), including the Operations Manager (OM), the Resource Manager (RM), and the Structured Call Interface (SCI).

Enabling dynamic resource definition for MODBLKS resources

You can enable dynamic resource definition for MODBLKS resources with either a resource definition data set (RDDS) or an IMSRSC repository.

About this task

To ensure that the procedure for enabling dynamic resource definition for MODBLKS goes smoothly, you should validate that your IMS environment is ready for the dynamic definition of MODBLKS resources.

Validating the IMS environment before enabling dynamic definition for MODBLKS resources

Before you enable dynamic resource definition for MODBLKS resources with either a resource definition data set (RDDS) or an IMSRSC repository, validate the IMS environment by performing the following steps.

Procedure

1. Verify DRD is not yet enabled, meaning either:
 - The MODBLKS keyword is not specified anywhere.
 - The MODBLKS=OLC keyword is specified in either the DFSCGxxx member or the COMMON_SERVICE_LAYER section of the DFSDfxxx member of the IMS PROCLIB data set.
2. Verify that IMS is stabilized in your test environment and the IMS.MODBLKS data set is complete and working properly.
3. Verify that the IMS in which you are enabling DRD has a Common Service Layer (CSL) defined. Specify the CSL parameters in either:
 - The COMMON_SERVICE_LAYER section of the DFSDfxxx member in the IMS PROCLIB data set
 - The DFSCGxxx member in the IMS PROCLIB data set

If you specify values in both the COMMON_SERVICE_LAYER section of the DFSDfxxx member and in the DFSCGxxx member, the CSL values in the DFSCGxxx member override the values in the COMMON_SERVICE_LAYER section of the DFSDfxxx member.

4. Verify that your in-house procedures that use the online change process for the resources defined in the IMS.MODBLKS data set have been copied and stored, and you have replacement procedures that use DRD commands.

Enabling dynamic definition for MODBLKS resources with a resource definition data set

After performing the initial verification of your IMS environment, you can enable dynamic resource definition (DRD) for MODBLKS resources with a resource definition data set (RDDS).

About this task

To enable dynamic resource definition (DRD) for MODBLKS resources with a resource definition data set (RDDS):

Procedure

1. Shut down IMS normally.
2. Change MODBLKS=OLC to MODBLKS=DYN in either the COMMON_SERVICE_LAYER section of the DFSDFxxx member or in the DFSCGxxx member in the IMS PROCLIB data set.
3. Specify the following keywords in the DYNAMIC_RESOURCES section of the DFSDFxxx member of the IMS PROCLIB data set:
 - AUTOEXPORT=AUTO or AUTOEXPORT=RDDS
 - AUTOIMPORT=AUTO or AUTOIMPORT=RDDS
 - RDDSdsn=(rdds1,rdds2,rdds3)
4. Use either the IEBGENER program or the ALLOCATE function of ISPF utilities to allocate the RDDS data sets.
5. Cold start IMS, specifying DFSDF=xxx in the control region execution parameters, where xxx identifies the suffix of the DFSDFxxx member in the IMS PROCLIB data set that IMS uses for this startup.
IMS loads the resource definitions from the IMS.MODBLKS data set because the defined RDDSs are empty. The IMS.MODBLKS data set is used only the first time you implement DRD, except for fallback purposes. IMS uses the resource definitions to create the internal control blocks required to manage the resources. When the initial checkpoint is taken, the resource definitions are automatically written out to one of the defined RDDSs because AUTOEXPORT=AUTO is specified. Also, because AUTOIMPORT=AUTO is specified and the RDDSs are no longer empty, IMS loads its resource and descriptor definitions from the RDDS with the most current data the next time that IMS coldstarts.

Restriction: After IMS starts with DRD enabled, you can no longer use the online change process to add, change, or delete database, application program, route code, or transaction resource definitions.

Related concepts

[“Overview of the IMSRSC repository” on page 37](#)

A repository is a generalized data storage facility that can be used to store any type of information. The IMS resource definition (IMSRSC) repository is a set of VSAM key sequenced data sets (KSDSs) used for storing information. The IMSRSC repository is a repository to store resource (and descriptor) definitions for IMS databases, transactions, programs, and routing codes. This repository is an alternative to the resource definition data set (RDDS) that is used with the dynamic resource definition (DRD) function.

Related reference

[“DFSCGxxx member of the IMS PROCLIB data set” on page 728](#)

Use the DFSCGxxx member of the IMS PROCLIB data set to specify parameters that are related to the Common Service Layer (CSL), including the Operations Manager (OM), the Resource Manager (RM), and the Structured Call Interface (SCI).

[“DYNAMIC_RESOURCES section of the DFSDFxxx member” on page 780](#)

The DYNAMIC_RESOURCES section of the DFSDFxxx member specifies options for import and export, log write ahead, and system resource definition data sets. This section is processed only if DRD is enabled (MODBLKS=DYN). If DRD is not enabled, this section is ignored. The section is defined by the header <SECTION=DYNAMIC_RESOURCES>. The DYNAMIC_RESOURCES section is valid in DB/DC, DBCTL, and DCCTL environments.

[“COMMON_SERVICE_LAYER section of the DFSDFxxx member” on page 762](#)

The COMMON_SERVICE_LAYER section of the DFSDFxxx member of the IMS PROCLIB data set specifies options for the Common Service Layer (CSL), such as IMSplex name, ACB sharing, global online change, command authorization checking, OLCSTAT, DRD, and global resource status. The section is defined by the header <SECTION=COMMON_SERVICE_LAYER>. The COMMON_SERVICE_LAYER section is valid in DB/DC, DBCTL, and DCCTL environments.

Enabling dynamic definition for MODBLKS resources with an IMSRSC repository

After performing the initial verification of your IMS environment, you can enable dynamic resource definition (DRD) for MODBLKS resources with an IMSRSC repository.

About this task

To enable IMS to use dynamic resource definition (DRD) with a repository:

Procedure

1. Shut down IMS normally.
2. Change MODBLKS=OLC to MODBLKS=DYN in either the COMMON_SERVICE_LAYER section of the DFSDFxxx member or in the DFSCGxxx member in the IMS PROCLIB data set.
3. In the DYNAMIC_RESOURCES section of the DFSDFxxx member of the IMS PROCLIB data set, specify AUTOIMPORT=AUTO or AUTOIMPORT=REPO.
4. In the DYNAMIC_RESOURCES section of the DFSDFxxx member of the IMS PROCLIB data set, you can optionally specify AUTOEXPORT=AUTO or AUTOEXPORT=REPO.
5. In the REPOSITORY section of the DFSDFxxx member of the IMS PROCLIB data set, specify the TYPE=IMSRSC keyword.
6. Cold start IMS, specifying DFSDF=xxx in the control region execution parameters, where xxx identifies the suffix of the DFSDFxxx member of the IMS PROCLIB data set that IMS uses for this startup.
If AUTOIMPORT=AUTO is specified in the DFSDFxxx member, IMS loads the resource definitions from the IMS.MODBLKS data set, if it exists, because the defined repositories are empty and there are no system resource definition data sets (RDDS). The IMS.MODBLKS data set is used only the first time you implement DRD, except for fallback purposes. IMS uses the resource definitions to create the internal control blocks required to manage the resources. If AUTOIMPORT=REPO is specified, IMS cold starts without any resource definitions because the defined repository is empty.
7. When IMS is started, issue the **EXPORT DEFN TARGET(REPO)** command to export the resource definitions to the repository.

Note: After IMS starts with DRD enabled, you can no longer use the online change process to add, change, or delete database, application program, route code, or transaction resources or resource definitions. Also, because AUTOIMPORT=AUTO or AUTOIMPORT=REPO is specified and the repository is no longer empty, IMS loads its resource and descriptor definitions from the repository the next time that IMS cold starts.

Related concepts

[“Overview of the IMSRSC repository” on page 37](#)

A repository is a generalized data storage facility that can be used to store any type of information. The IMS resource definition (IMSRSC) repository is a set of VSAM key sequenced data sets (KSDSs) used for storing information. The IMSRSC repository is a repository to store resource (and descriptor) definitions for IMS databases, transactions, programs, and routing codes. This repository is an alternative to the resource definition data set (RDDS) that is used with the dynamic resource definition (DRD) function.

[“IMSRSC repository and RS catalog repository data sets” on page 160](#)

The IMSRSC repository uses a set of VSAM key-sequenced data sets (KSDSs) that you define to store the resource and descriptor definitions for the members of an IMSplex in a common repository.

Related tasks

[“Defining the IMSRSC repository” on page 40](#)

Before you can use the IMSRSC repository to store and retrieve resource and descriptor definitions, you must define it. In addition, IMS and the Resource Manager (RM) must have the repository enabled, the Repository Server (RS) must be started and active, and the repository must be started.

Related reference

[“DFSCGxxx member of the IMS PROCLIB data set” on page 728](#)

Use the DFSCGxxx member of the IMS PROCLIB data set to specify parameters that are related to the Common Service Layer (CSL), including the Operations Manager (OM), the Resource Manager (RM), and the Structured Call Interface (SCI).

[“DYNAMIC_RESOURCES section of the DFSDfxxx member” on page 780](#)

The DYNAMIC_RESOURCES section of the DFSDfxxx member specifies options for import and export, log write ahead, and system resource definition data sets. This section is processed only if DRD is enabled (MODBLKS=DYN). If DRD is not enabled, this section is ignored. The section is defined by the header <SECTION=DYNAMIC_RESOURCES>. The DYNAMIC_RESOURCES section is valid in DB/DC, DBCTL, and DCCTL environments.

[“REPOSITORY section of the DFSDfxxx member” on page 805](#)

The REPOSITORY section of the DFSDfxxx member specifies the repository types that are to be enabled at IMS. The valid type is: IMSRSC repository, which is used to store the stored resource definitions for DRD resources. The section must begin with the header <SECTION=REPOSITORY>. The REPOSITORY section is valid in DB/DC, DBCTL, and DCCTL environments.

[“COMMON_SERVICE_LAYER section of the DFSDfxxx member” on page 762](#)

The COMMON_SERVICE_LAYER section of the DFSDfxxx member of the IMS PROCLIB data set specifies options for the Common Service Layer (CSL), such as IMSplex name, ACB sharing, global online change, command authorization checking, OLCSTAT, DRD, and global resource status. The section is defined by the header <SECTION=COMMON_SERVICE_LAYER>. The COMMON_SERVICE_LAYER section is valid in DB/DC, DBCTL, and DCCTL environments.

Enabling dynamic definition for MSC resources

Dynamic definition for MSC resources is enabled by specifying MSCRSCS=DYN in the MSC section of the DFSDfxxx member of the IMS PROCLIB data set.

Before you begin

Before you can enable dynamic resource definition for MSC resources, the Common Service Layer (CSL) must be enabled with at least the Structured Call Interface (SCI) and the Operations Manager (OM).

About this task

After you enable dynamic resource definition for MSC resources, you can create, modify, and delete MSC resources in an online IMS system by using IMS type-2 CREATE, UPDATE, and DELETE commands.

Any changes that are made to MSC resources dynamically are not saved across a cold start unless you export the modified definitions to the IMSRSC repository or code the changes to the MSC resources into stage-1 system definition macros.

To enable dynamic definition for MSC resources, complete the following steps:

Procedure

1. Specify MSCRSCS=DYN in the MSC section of the DFSDfxxx member of the IMS PROCLIB data set.
2. Cold start IMS.
3. Confirm that dynamic definition is enabled for MSC resources by issuing the QUERY MEMBER TYPE(IMS) command.

When dynamic resource definition is enabled for MSC resources, the command output includes DYNMSC in the local attributes.

Related reference

“MSC section of the DFSDFxxx member” on page 797

The MSC section of the DFSDFxxx member of the IMS PROCLIB data set specifies options for the Multiple Systems Coupling (MSC) function of IMS. The section header must be specified as <SECTION=MSC>. The MSC section is valid in DB/DC and DCCTL environments.

Creating runtime resource and descriptor definitions

When dynamic resource definition (DRD) is enabled, you can define runtime resources and descriptor definitions to IMS dynamically, eliminating the requirement to use the online change process or to cold start IMS.

When a resource or descriptor is defined to IMS, IMS stores information about the resource or descriptor, such as the attributes and the status, in control blocks. The information that is kept in the control blocks is referred to as the runtime resource or descriptor definition. Although the overall process for creating runtime database, application program, transaction, routing code, MSC physical link, MSC logical link, MSC MSNAME, and MSC remote LTERM definitions is the same, there are minor variations in the steps you complete.

When DRD is enabled for MODBLKS resources, runtime resources can be created by:

- Importing the stored resource definitions from the IMS.MODBLKS data set during an IMS cold start.
- Importing the stored resource definitions from the resource definition data set (RDDS) with the automatic import function or the **IMPORT DEFN SOURCE (RDDS)** command.
- Importing the stored resource definitions from the IMSRSC repository with the automatic import function or the **IMPORT DEFN SOURCE (REPO)** command.
- Using the appropriate **CREATE** command (according to the type of resource definition you want to create).

When DRD is enabled for MODBLKS resources, runtime descriptor definitions can be created by:

- Importing the stored descriptor definitions from the RDDS with the automatic import function or the **IMPORT DEFN SOURCE (RDDS)** command.
- Importing the stored descriptor definitions from the repository with the automatic import function or the **IMPORT DEFN SOURCE (REPO)** command.
- Using the appropriate **CREATE** command (according to the type of descriptor definition you want to create).

When DRD is enabled for MSC resources, runtime resources can be created by:

- Importing the stored resource definitions from the IMSRSC repository with the automatic import function.
- Importing the stored resource definitions from the DFSCLL3x member of the IMS.SDFSRESL data set with the automatic import function.
- Using the appropriate **CREATE** command (according to the type of resource definition you want to create).

The resource and descriptor definitions that you create dynamically using either the **CREATE** command or the **IMPORT DEFN** command exist only during the current execution of the IMS system, and they are recoverable across a warm or emergency restart.

To preserve the MODBLKS resource and descriptor definitions across a cold start, export the MODBLKS definitions to an RDDS or an IMSRSC repository before IMS terminates. Or, if the AUTOEXPORT parameter is set to AUTO, RDDS, or REPO in the DFSDFxxx PROCLIB member, the MODBLKS resources will be exported automatically at the next IMS checkpoint. You can then import the stored MODBLKS definitions from the RDDS or the repository back into IMS either during cold start processing by using the automatic import function, or when IMS is up and running by using the **IMPORT DEFN** command.

To preserve MSC resource definitions across a cold start, export the MSC definitions to an IMSRSC repository by using the automatic export function. The MSC resource definitions are automatically

exported to the repository at IMS checkpoint time and before IMS shutdown. You can then import the MSC definitions during cold start processing from the IMSRSC repository by using the automatic import function.

Each resource or descriptor definition can be created individually, unlike the online change process where either all resource definitions must be created or no resource definitions are created.

Related concepts

[“Overview of the IMSRSC repository” on page 37](#)

A repository is a generalized data storage facility that can be used to store any type of information. The IMS resource definition (IMSRSC) repository is a set of VSAM key sequenced data sets (KSDSs) used for storing information. The IMSRSC repository is a repository to store resource (and descriptor) definitions for IMS databases, transactions, programs, and routing codes. This repository is an alternative to the resource definition data set (RDDS) that is used with the dynamic resource definition (DRD) function.

[“Managing resource and descriptor definitions” on page 31](#)

With dynamic resource definition (DRD) enabled, you can perform several tasks to manage the resource and descriptor definitions for your IMS system.

Related tasks

[“Creating resource and descriptor definitions in the IMSRSC repository” on page 58](#)

You can create resource and descriptor definitions in the IMSRSC repository for one or more new or existing IMS systems in your IMSplex.

Related reference

[CREATE commands \(Commands\)](#)

[IMPORT DEFN SOURCE\(REPO | RDDS\) command \(Commands\)](#)

Creating runtime database resource and descriptor definitions with the CREATE command

With dynamic resource definition (DRD) enabled, you can create runtime resources and resource descriptors dynamically, eliminating the need to use the online change process or the batch system definition process with an IMS cold start.

About this task

Create runtime database resource and descriptor definitions using the CREATE DB and CREATE DBDESC commands.

Procedure

1. Optional: Issue a **QUERY DBDESC DEFAULT(Y) SHOW (ALL)** command to view the current database default settings and evaluate whether they meet your requirements for the new database resource or descriptor definition.

If the default settings do not meet your requirements, you have the following options:

- Override the default settings by issuing the CREATE command with parameter values that meet your requirements.
- Create the resource or descriptor definition based on an existing resource or descriptor definition by using either the LIKE (RSC(*resource_name*)) keyword or the LIKE (DESC(*descriptor_name*)) keyword on the CREATE command.
- Create a default descriptor by issuing a **CREATE DBDESC NAME() SET (DEFAULT(Y))** command with the settings that meet your requirements.

The next two steps can be performed in any order.

2. Issue a **CREATE DB** or **CREATE DBDESC** command to create a database resource definition or database descriptor definition, respectively.
3. Define the database, as well as its relationships to other resources, by running the Database Description Generation (DBDGEN) utility.

What to do next

After dynamically defining a database resource, before it can be used, a database management block (DMB) must reside in the IMS.ACBLIB data set. If the database that was dynamically defined is a main storage database (MSDB):

- The database segments must be in the MSDBINIT data set.
- The MSDBs must be defined in the DBFMSDBx procedure.
- The DBFMSDBx procedure must be in the IMS.PROCLIB data set.

For information about the CREATE command, see *IMS Version 15.4 Commands, Volume 1: IMS Commands A-M*.

For information about loading MSDB segments into the MSDBINIT data set, see [MSDB Maintenance utility \(DBFDBMA0\) \(Database Utilities\)](#).

For information about the DBFMSDBx procedure, see [“DBFMSDBx member of the IMS PROCLIB data set” on page 725](#).

For general information about MSDBs, see *IMS Version 15.4 Database Administration*.

Creating runtime application program resource and descriptor definitions with the CREATE command

With dynamic resource definition (DRD) enabled, you can create runtime application program resources and resource descriptors dynamically, eliminating the need to use the online change process or the batch system definition process with an IMS cold start.

About this task

Create runtime application program resource and descriptor definitions using the CREATE PGM and CREATE PGMDESC commands.

Procedure

1. Optional: Issue a **QUERY PGMDESC DEFAULT(Y) SHOW (ALL)** command to view the current application program default settings and evaluate whether they meet your requirements for the new application program resource or descriptor definition.

If the default settings do not meet your requirements, you have the following options:

- Override the default settings by issuing the CREATE command with parameter values that meet your requirements.
- Create the resource or descriptor definition based on an existing resource or descriptor definition by using either the LIKE (RSC(*resource_name*)) keyword or the LIKE (DESC(*descriptor_name*)) keyword.
- Create a default descriptor by issuing a **CREATE PGMDESC NAME() SET (DEFAULT(Y))** command with the settings that meet your requirements.

The next two steps can be performed in any order.

2. Issue a **CREATE PGM** or **CREATE PGMDESC** command to create application program resources or descriptors definitions, respectively.
3. Define the application program, as well as its relationships to other resources, by running the Program Specification Block Generation (PSBGEN) utility.

Results

For the details about parameters for the CREATE command, see *IMS Version 15.4 Commands, Volume 1: IMS Commands A-M*.

Creating runtime Fast Path routing code resource and descriptor definitions with the CREATE command

With dynamic resource definition (DRD) enabled, you can create runtime resources and resource descriptors dynamically, eliminating the need to use the online change process or the batch system definition process with an IMS cold start.

About this task

Create runtime Fast Path routing code resources and descriptor definitions using the **CREATE RTC** and **CREATE RTCDESC** commands.

Procedure

1. Optional: Issue a **QUERY RTCDESC DEFAULT(Y) SHOW (ALL)** command to view the current Fast Path routing code default settings and evaluate whether they meet your requirements for the new Fast Path routing code resource or descriptor definition.

If the default settings do not meet your requirements, you have the following options:

- Override the default settings by issuing the CREATE command with parameter values that meet your requirements.
 - Create the resource or descriptor definition based on an existing resource or descriptor definition by using either the LIKE (RSC(*resource_name*)) keyword or the LIKE (DESC(*descriptor_name*)) keyword
 - Create a default descriptor by issuing a **CREATE RTCDESC NAME() SET (DEFAULT(Y))** command with the settings that meet your requirements.
2. Issue a **CREATE RTC** to create Fast Path routing code resources or a **CREATE RTCDESC** command to create Fast Path routing code descriptor definitions.

Results

For the details about parameters for the **CREATE** command, see *IMS Version 15.4 Commands, Volume 1: IMS Commands A-M*.

If you are using the IMSRSC repository or a set of system resource definition data sets (RDDSs) to store your Fast Path routing code resource and descriptor definitions, the routing codes associated with both Fast Path potential FP(P) and FP(E) transactions are maintained in the repository or RDDS.

If it was not specified in the **EXPORT DEFN** command or in the RDDS to Repository utility (CSLURP10), the routing code for the FP(E) transaction is automatically created in the repository by RM.

Related concepts

[“Overview of the IMSRSC repository” on page 37](#)

A repository is a generalized data storage facility that can be used to store any type of information. The IMS resource definition (IMSRSC) repository is a set of VSAM key sequenced data sets (KSDSs) used for storing information. The IMSRSC repository is a repository to store resource (and descriptor) definitions for IMS databases, transactions, programs, and routing codes. This repository is an alternative to the resource definition data set (RDDS) that is used with the dynamic resource definition (DRD) function.

Creating runtime transaction resource and descriptor definitions with the CREATE command

With dynamic resource definition (DRD) enabled, you can create runtime resources and resource descriptors dynamically, eliminating the need to use the online change process or the batch system definition process with an IMS cold start.

About this task

Create runtime transaction resource and descriptor definitions using the CREATE TRAN and CREATE TRANDESC commands.

In addition to using the CREATE TRAN command to create transaction resources, you can use the Destination Creation exit routine (DFSINSX0).

To create runtime transaction resource and descriptor definitions using the CREATE TRAN and CREATE TRANDESC commands, perform the following procedure:

Procedure

1. Optional: Issue a **QUERY TRANDESC DEFAULT(Y) SHOW (ALL)** command to view the current transaction default settings and evaluate whether they meet your requirements for the new transaction resource or descriptor definition.

If the default settings do not meet your requirements, you have the following options:

- Override the default settings by issuing the CREATE command with parameter values that meet your requirements.
 - Create the resource or descriptor definitions based on an existing resource or descriptor definition by using either the LIKE (RSC(*resource_name*)) keyword or the LIKE (DESC(*descriptor_name*)) keyword.
 - Create a default descriptor by issuing a **CREATE TRANDESC NAME() SET (DEFAULT(Y))** command with the settings that meet your requirements.
2. Issue a CREATE TRAN or CREATE TRANDESC command to create transaction resources or descriptor definitions, respectively.

Results

For the details about parameters for the CREATE command, see *IMS Version 15.4 Commands, Volume 1: IMS Commands A-M*.

Creating runtime resource and descriptor definitions in an IMSplex with the CREATE command

If you have a mixture of DRD-enabled and DRD-disabled IMS systems in an IMSplex, you can create resource or descriptor definitions for this environment.

About this task

Perform the following procedure:

Procedure

1. Perform an online change process for the IMS.MODBLKS data set on the IMS systems that have not migrated to DRD.
2. Issue **CREATE** commands for the resource or descriptor definitions you want to create on the IMS systems that have DRD enabled.

Creating runtime MSC resource definitions with the CREATE command

When dynamic resource definition (DRD) is enabled for MSC resources, you can create runtime MSC resources in an online IMS system by using the IMS type-2 **CREATE** commands, including **CREATE LTERM**, **CREATE MSLINK**, **CREATE MSNAME**, and **CREATE MSPLINK**.

About this task

Create MSC resources such as definitions for MSC physical links, logical links, logical link paths, and remote terminals by using the appropriate **CREATE** command for the type of resource definition that you want to create.

The resource definitions that you create by using the **CREATE** commands are not saved across a cold start unless you export the definitions to the IMSRSC repository or code the changes to the MSC resources into stage-1 system definition macros.

To create MSC resource definitions:

Procedure

1. Optional: Issue a **QUERY** command for the type of resource definition that you want to create, to view settings and evaluate whether they meet your requirements for the new MSC resource definition.
2. Issue the **CREATE** command for the type of MSC resource you want to create. MSC resources must be created in the following order for the MSC link to be usable: CREATE MSPLINK, CREATE MSLINK, CREATE MSNAME, and CREATE LTERM.

Related tasks

[Enabling the IMSRSC repository for MSC resources \(Communications and Connections\)](#)

Related reference

[CREATE LTERM command \(Commands\)](#)

[CREATE MSLINK command \(Commands\)](#)

[CREATE MSNAME command \(Commands\)](#)

[CREATE MSPLINK command \(Commands\)](#)

Creating resource and descriptor definitions in the IMSRSC repository

You can create resource and descriptor definitions in the IMSRSC repository for one or more new or existing IMS systems in your IMSplex.

Creating MODBLKS resource and descriptor definitions in the IMSRSC repository

You can create MODBLKS resource and descriptor definitions in the IMSRSC repository for one or more new or existing IMS systems in your IMSplex.

Procedure

1. Define the IMSRSC repository.
2. Create the MODBLKS resource and descriptor definitions in the repository for one or more IMS systems by using one of the following procedures:

- Run the RDDS to Repository utility (CSLURP10) by using a generated RDDS. Specify `IMSPLEX(NAME=plxnm IMSID(imsx))`.

In the JCL, *imsx* is the list of one or more IMS IDs in the IMSplex that the CSLURP10 utility populates in the repository. The IMS IDs that you specify can be for either new or existing IMS systems.

Use the system RDDS generated by IMS at system checkpoint, or generate the RDDS with one of the following methods:

- By using an **EXPORT DEFN TARGET(RDDS)** command
- From the IMS logs, by using the CSLURCLO utility
- From MODBLKS, by using the CSLURCM0 utility
- Export the resource and descriptor definitions from an active IMS system by using the **EXPORT DEFN TARGET(REPO) NAME(*) TYPE(ALL)** command.

If you are creating resource and descriptor definitions in the repository for a single IMS system or for multiple IMS systems that each need a unique set of definitions, issue the **EXPORT DEFN TARGET(REPO) NAME(*) TYPE(ALL)** command. In a non-cloned environment, the **EXPORT DEFN TARGET(REPO)** command must be issued to each IMS for which the resource definitions and descriptors are to be exported to the repository. Because the **EXPORT DEFN**

TARGET (REPO) command is processed only by the command master IMS, a separate **EXPORT DEFN TARGET (REPO)** command must be issued to each IMS system. You can use the ROUTE keyword on the OM API to specify the IMS to which the command is routed. You do not have to specify the SET(IMSID()) keyword, because IMS defaults the IMS ID to the command master IMS.

If you are creating resource and descriptor definitions in the repository for multiple IMS systems with the same set of definitions, issue the **EXPORT DEFN TARGET (REPO) NAME(*) TYPE(ALL)** command with the option SET(IMSID(*imslist*)). In the command, *imslist* is the list of IMS IDs of one or more IMS systems in the IMSplex for which the resource and descriptor definitions are to be created in the repository. An IMS resource list containing the definitions is created in the repository for each IMS listed in *imslist*.

- To create resource and descriptor definitions in the repository for a new IMS system that has not yet been cold started, perform the following steps:
 - a. Start IMS by obtaining the resource definitions from the MODBLKS data set, or a system RDDS, or you can come up with no resources and use the **CREATE** commands to create resource definitions after the IMS cold start.
 - b. After the IMS cold start, when all resource and descriptor definitions have been created, issue the **EXPORT DEFN TARGET (REPO)** command with options NAME(*) TYPE(ALL) to export the resource and descriptor definitions from IMS to the repository. The **EXPORT DEFN TARGET (REPO)** command must be routed to the IMS system for which the resource and descriptor definitions are to be exported, by using the ROUTE keyword on the OM API.
- 3. If one or more IMS systems in the IMSplex consist of remote transactions and MSC is defined, the SIDR and SIDL values in the repository might not be correct. In this case, perform the following steps:
 - a) If the IMS system is cold started from the repository, update the SIDR and SIDL values at each IMS by issuing the **UPDATE TRAN SET(SIDR(),SIDL(),REMOTE())** command for the IMS system.
 - b) Update the remote transaction definitions in the repository by issuing the **EXPORT DEFN TARGET (REPO)** command with options NAME(*rmtrannames*) TYPE(TRAN).

Related concepts

[“Overview of the IMSRSC repository” on page 37](#)

A repository is a generalized data storage facility that can be used to store any type of information. The IMS resource definition (IMSRSC) repository is a set of VSAM key sequenced data sets (KSDSs) used for storing information. The IMSRSC repository is a repository to store resource (and descriptor) definitions for IMS databases, transactions, programs, and routing codes. This repository is an alternative to the resource definition data set (RDDS) that is used with the dynamic resource definition (DRD) function.

[“Creating runtime resource and descriptor definitions” on page 53](#)

When dynamic resource definition (DRD) is enabled, you can define runtime resources and descriptor definitions to IMS dynamically, eliminating the requirement to use the online change process or to cold start IMS.

[“Exporting MODBLKS resource and descriptor definitions to an IMSRSC repository” on page 81](#)

You can export resource and descriptor definitions from IMS to an IMSRSC repository by using the automatic export function or by issuing the EXPORT DEFN TARGET(REPO) command. You can export resource and descriptor definitions from the IMS system to the repository and have them defined for one or more new or existing IMS systems in your IMSplex.

Related tasks

[“Defining the IMSRSC repository” on page 40](#)

Before you can use the IMSRSC repository to store and retrieve resource and descriptor definitions, you must define it. In addition, IMS and the Resource Manager (RM) must have the repository enabled, the Repository Server (RS) must be started and active, and the repository must be started.

Related reference

[Repository to RDDS utility \(CSLURP20\) \(System Utilities\)](#)

[RDDS to Repository utility \(CSLURP10\) \(System Utilities\)](#)

[UPDATE TRAN command \(Commands\)](#)

[EXPORT command \(Commands\)](#)

Creating MSC resource definitions in the IMSRSC repository

You can create MSC resource definitions in the IMSRSC repository for one or more new or existing IMS systems in your IMSplex by using the IMS type-2 **CREATE** commands.

Before you begin

Before you create MSC resource definitions in the IMSRSC repository, ensure that the following prerequisites are met:

- The IMSRSC repository is defined.
- Dynamic resource definition for MSC resources is enabled.
- The IMSRSC repository is enabled for MSC resources.

Procedure

1. Issue the **CREATE** command for the type of MSC resource that you want to create.
You must create MSC resources in the following order for the MSC link to be usable:
 - a. CREATE MSPLINK
 - b. CREATE MSLINK
 - c. CREATE MSNAME
 - d. CREATE LTERM

The **CREATE** command must be issued to each IMS in each IMSplex for which the resource definitions are to be exported to the repository. You can use the ROUTE keyword on the OM API to specify the IMS to which the command is routed.

2. Specify AUTOEXPORT=AUTO or REPO in the DYNAMIC_RESOURCES section of the DFSDFXxx member in the IMS PROCLIB data set.

At the next IMS checkpoint, the MSC resource definitions that you created since the last automatic export are automatically exported to the IMSRSC repository. The IMS checkpoint can be initiated either by issuing the **/CHECKPOINT** command or automatically by the IMS system.

If you use the **/CHECKPOINT** command to initiate an IMS checkpoint, the command must be routed to each IMS in each IMSplex in which the MSC resources are defined.

Results

At the end of the automatic export processing to the IMSRSC repository, the X'22' map byte X'51' automatic export complete log record is written. The log record indicates the IMS IDs that the exported definitions are defined for. A count of the resources that were exported for each resource type is also included in the 'X22' subtype X'51' log record.

Related tasks

[Enabling the IMSRSC repository for MSC resources \(Communications and Connections\)](#)

[“Enabling dynamic definition for MSC resources” on page 52](#)

Dynamic definition for MSC resources is enabled by specifying MSCRSCS=DYN in the MSC section of the DFSDFXxx member of the IMS PROCLIB data set.

[“Defining the IMSRSC repository” on page 40](#)

Before you can use the IMSRSC repository to store and retrieve resource and descriptor definitions, you must define it. In addition, IMS and the Resource Manager (RM) must have the repository enabled, the Repository Server (RS) must be started and active, and the repository must be started.

Related reference

[CREATE LTERM command \(Commands\)](#)

[CREATE MSLINK command \(Commands\)](#)

[CREATE MSNAME command \(Commands\)](#)

[CREATE MSPLINK command \(Commands\)](#)

[/CHECKPOINT command \(Commands\)](#)

[“MSC section of the DFSDFxxx member” on page 797](#)

The MSC section of the DFSDFxxx member of the IMS PROCLIB data set specifies options for the Multiple Systems Coupling (MSC) function of IMS. The section header must be specified as <SECTION=MSC>. The MSC section is valid in DB/DC and DCCTL environments.

[“DYNAMIC_RESOURCES section of the DFSDFxxx member” on page 780](#)

The DYNAMIC_RESOURCES section of the DFSDFxxx member specifies options for import and export, log write ahead, and system resource definition data sets. This section is processed only if DRD is enabled (MODBLKS=DYN). If DRD is not enabled, this section is ignored. The section is defined by the header <SECTION=DYNAMIC_RESOURCES>. The DYNAMIC_RESOURCES section is valid in DB/DC, DBCTL, and DCCTL environments.

Updating runtime resource and descriptor definitions

When dynamic resource definition (DRD) is enabled, you can update runtime resource and descriptor definitions dynamically, eliminating the need to use the online change process or to cold start IMS. Although the overall process for updating runtime database, application program, transaction, routing code, MSC physical link, MSC logical link, MSC MSNAME, and MSC remote LTERM definitions is the same, there are minor variations in the steps you complete.

When DRD is enabled for MODBLKS resources, runtime resources can be updated by:

- Importing the stored resource definitions from the resource definition data set (RDDS) by using the **IMPORT DEFN SOURCE(RDDS)** command.
- Importing the stored resource definitions from the IMSRSC repository by using the **IMPORT DEFN SOURCE(REPO)** command.
- Using the appropriate **UPDATE** command (according to the type of resource definition you want to update).

When DRD is enabled for MODBLKS resources, runtime descriptor definitions can be updated by:

- Importing the stored descriptor definitions from the RDDS by using the **IMPORT DEFN SOURCE(RDDS)** command.
- Importing the stored descriptor definitions from the repository by using the **IMPORT DEFN SOURCE(REPO)** command.
- Using the appropriate **UPDATE** command (according to the type of descriptor definition you want to update).

When DRD is enabled for MSC resources, runtime resources can be updated by:

- Using the appropriate **UPDATE** command (according to the type of descriptor definition you want to update).

The changes that you make to resource and descriptor definitions by using the **UPDATE** and **IMPORT** commands exist during the current execution of the IMS system and are recoverable across a warm or emergency restart. IMS uses change lists to preserve the changes across a warm or emergency restart. To preserve the changes across a cold start, you must:

1. Export the updated definitions to an RDDS or the repository before IMS terminates. The definitions can be exported either automatically by using automatic export, or manually by using the **EXPORT DEFN** command.
2. Import the stored definitions from the RDDS or repository back into IMS. The definitions can be imported either automatically during cold start processing by using automatic import, or manually by using the **IMPORT DEFN** command when IMS is up and running.

If the attributes specified on the **UPDATE** command are already defined for the resource:

- No update is made

- No resources are quiesced
- No log record is created
- A completion code of zero is returned

By taking no action, IMS avoids unnecessary processor usage.

Unlike the online change process where either all resource definitions are updated or no resource definitions are updated, each resource or descriptor definition can be updated individually.

Related concepts

[“Overview of the IMSRSC repository” on page 37](#)

A repository is a generalized data storage facility that can be used to store any type of information. The IMS resource definition (IMSRSC) repository is a set of VSAM key sequenced data sets (KSDSs) used for storing information. The IMSRSC repository is a repository to store resource (and descriptor) definitions for IMS databases, transactions, programs, and routing codes. This repository is an alternative to the resource definition data set (RDDS) that is used with the dynamic resource definition (DRD) function.

Related tasks

[“Updating MODBLKS resource and descriptor definitions in the IMSRSC repository for multiple IMS systems with the same set of definitions” on page 68](#)

You can update MODBLKS resource and descriptor definitions in the IMSRSC repository for multiple IMS systems with the same set of definitions.

[“Updating MODBLKS resource and descriptor definitions in the IMSRSC repository for a single IMS or for multiple IMSs with unique definitions” on page 67](#)

You can update MODBLKS resource and descriptor definitions in the IMSRSC repository for a single IMS system or for multiple IMS systems that each need a unique set of definitions.

Related reference

[IMPORT DEFN SOURCE\(REPO | RDDS\) command \(Commands\)](#)

[UPDATE commands \(Commands\)](#)

Updating runtime database resource and descriptor definitions with the UPDATE command

With dynamic resource definition (DRD) enabled, you can update runtime resources and resource descriptors dynamically, eliminating the need to use the online change process or the batch system definition process with an IMS cold start.

Before you begin

You cannot update database resource definitions if there is work in progress for the database, or if the database is currently in use.

About this task

Update runtime database resource and descriptor definitions using the UPDATE DB and UPDATE DBDESC commands.

Procedure

1. Check for work in progress using a QRY DB SHOW(WORK) command. If there is work in progress, either:
 - a) Wait for the work to finish.
 - b) Address the work in progress.

Examples of work in progress include a command is in progress for the database, or the database is in use.
2. Stop the database using either an **UPDATE DB STOP(ACCESS)** or **/DBR DB** command

3. Issue an **UPDATE DB** or **UPDATE DBDESC** command specifying the values you want to change for the database or descriptor definitions, respectively.

Updating runtime application program resource and descriptor definitions with the UPDATE command

With dynamic resource definition (DRD) enabled, you can update runtime application program resources and resource descriptors dynamically, eliminating the need to use the online change process or the batch system definition process with an IMS cold start.

Before you begin

You cannot update application program resource definitions if there is work in progress for the application program. In a local queues environment, if there are queued messages for transactions associated with the program being updated, the update fails. In a shared queues environment, if there are queued messages for a transaction that is associated with the program being updated, the update succeeds. However, the update might succeed on some IMS systems and fail on others.

About this task

Update runtime application program resource and descriptor definitions using the **UPDATE PGM** and **UPDATE PGMDESC** commands.

Procedure

1. Check for work in progress using a **QRY PGM SHOW(WORK)** command. If there is work in progress, either:
 - a) Wait for the work to finish.
 - b) Address the work in progress.
Examples of work in progress include a command being in progress for the program or the program being scheduled.
2. Check whether any transactions reference the program using a **QRY PGM SHOW(TRAN)** command. If any of the program attributes you plan to update (such as FP or BMPTYPE) conflict with any transactions that reference the program, before updating the program definition, you must either:
 - a) Delete the conflicting transaction definitions that reference the program.
 - b) Update the transaction definitions to reference a different program before updating the program.
To delete a transaction, issue a **DELETE TRAN** command. To update a transaction, issue an **UPDATE TRAN** command.
3. If the FP attribute is being changed from FP(E) to FP(N), determine whether any routing codes reference the program by using a **QRY PGM SHOW(RTC)** command. If there are routing codes that reference the program, before updating the program definition, you must either:
 - Delete all the routing codes that reference the program.
 - Update the routing code definitions to reference a different program before updating the program.
To delete a routing code associated with an FP(E) transaction, issue a **DELETE TRAN** command. To delete a routing code associated with an FP(P) transaction, issue a **DELETE RTC** command.
4. The next step varies depending on where the application program is running.
 - If the program is running in an IFP region, issue a **/STOP REGION** command to terminate the program.
 - If the program is running in a BMP or JBP region, either wait for the program to finish, or issue a **/STOP REGION** command to terminate the program.

- If the program is a BMP that is processing a WFI transaction, issue a **/STOP REGION** command to terminate the program.
 - If the program is running in an MPP or JMP region, issue a **/STOP PGM** or **UPDATE PGM STOP(SCHD)** command to terminate the program.
5. Issue the **UPDATE PGM** or **UPDATE PGMDESC** command specifying the values you want to change for the application program or descriptor definitions, respectively.

Results

If all the attributes specified by the **UPDATE** command are already defined for the resource, no update is made, no resources are quiesced, no log record is created, and a completion code of zero is returned. This avoids unnecessary overhead when no action needs to be taken.

For the details about parameters for the **UPDATE** and **QUERY** commands, see *IMS Version 15.4 Commands, Volume 2: IMS Commands N-V*.

Updating runtime Fast Path routing code resource and descriptor definitions with the UPDATE command

With dynamic resource definition (DRD) enabled, you can update runtime Fast Path routing code resource and descriptor definitions dynamically, eliminating the requirement to use the online change process or the batch system definition process with an IMS cold start.

Before you begin

If the program is scheduled, the routing code cannot be updated. If the program is scheduled, you must stop the region before you issue the **UPDATE RTC** command.

About this task

Update runtime Fast Path routing code resources and descriptor definitions using the **UPDATE RTC** and **UPDATE RTCDESC** commands.

Procedure

1. Check for work in progress by using a **QRY RTC SHOW(WORK)** command. If there is work in progress, either:
 - Wait for the work to finish.
 - Address the work in progress.

Examples of work in progress include a command in progress for the routing code or an active routing code.

2. If the application program is running in an IFP region, terminate the program by using a **/STOP REGION** command.
3. Issue an **UPDATE RTC** or **UPDATE RTCDESC** command, specifying values you want to change for the Fast Path routing code resources or descriptor definitions.

To update a routing code associated with a Fast Path exclusive FP(E) transaction, you must issue an **UPDATE TRAN** command. The **UPDATE TRAN** command updates the transaction definition and the associated routing code definition.

Results

For the details about parameters for the **UPDATE** and **QUERY** commands, see *IMS Version 15.4 Commands, Volume 2: IMS Commands N-V*.

If you are using the IMSRSC repository or a set of system resource definition data sets (RDDSs) to store your Fast Path routing code resource and descriptor definitions, the routing codes associated with both Fast Path potential FP(P) and FP(E) transactions are maintained in the repository or RDDS.

Related concepts

[“Overview of the IMSRSC repository” on page 37](#)

A repository is a generalized data storage facility that can be used to store any type of information. The IMS resource definition (IMSRSC) repository is a set of VSAM key sequenced data sets (KSDSs) used for storing information. The IMSRSC repository is a repository to store resource (and descriptor) definitions for IMS databases, transactions, programs, and routing codes. This repository is an alternative to the resource definition data set (RDDS) that is used with the dynamic resource definition (DRD) function.

Updating runtime transaction resource and descriptor definitions with the UPDATE command

With dynamic resource definition (DRD) enabled, you can update runtime resources and resource descriptors dynamically, eliminating the need to use the online change process or the batch system definition process with an IMS cold start.

Before you begin

You cannot update a transaction if it is in use. If a transaction is in use, the update fails. In a local queues environment, if there are queued messages for the transaction, the update fails. In a shared queues environment, if there are queued messages for the transaction, the update succeeds.

About this task

Update runtime transaction resource and descriptor definitions using the UPDATE TRAN and UPDATE TRANDESC commands.

Procedure

1. Check for work in progress by using a **QRY TRAN SHOW(WORK)** command and either wait for the work to finish or address the work in progress.

Examples of work in progress are a command in progress for the transaction, a scheduled transaction, a transaction in conversation, or a suspended transaction.

- To wait for work in progress to complete, issue either a **/PURGE TRAN** or **UPDATE TRAN STOP(Q)** command to stop the transaction from being queued, but to allow existing queued messages to be processed.
 - If you do not want to wait for work in progress, or if the transaction is a WFI transaction, or if the transaction is running in a PWFI=Y MPP region, stop the transaction by issuing a **/STOP TRAN** or **UPDATE TRAN STOP(SCHD,Q)** command. If you are stopping the transaction in a non-shared queues environment, no messages can be queued for the transaction. To dequeue messages for the transaction, issue the **QUEUE TRAN OPTION(DEQALL)** command.
2. The next step varies depending on where the transaction is running.
 - If the transaction is running in an IFP region, terminate the program by issuing a **/STOP REGION**.
 - If the transaction is a non-WFI transaction running in a message-driven BMP, either wait for the program to finish, or terminate the program by issuing a **/STOP REGION** command.
 - If the transaction is a WFI transaction running in a message-driven BMP, terminate the program by issuing a **/STOP REGION** command.
 3. If the transaction has messages on the suspend queue, and you are running in a non-shared queues environment, you must either:
 - Process the messages on the suspend queue.
 - Delete the messages. To delete the messages on the suspend queue, stop the transaction by issuing a **/STOP TRAN** or **UPDATE TRAN STOP(SCHD)** command.

- a) Move the messages to the ready queue by issuing either a **/DEQ SUSPEND** or **UPDATE TRAN START(SUSPEND)** command.
- b) After the messages are on the ready queue, you can delete them by issuing a **QUEUE TRAN OPTION(DEQALL)** command.
4. Issue the **UPDATE TRAN** or **UPDATE TRANDESC** command for the resource or descriptor definition you want to update, respectively.

Results

For the details about parameters for the UPDATE and QUERY commands, see *IMS Version 15.4 Commands, Volume 2: IMS Commands N-V*.

Updating runtime resource and descriptor definitions in an IMSplex with the UPDATE command

If you have a mixture of DRD-enabled and DRD-disabled IMS systems in an IMSplex, you can update resources or descriptor definitions for this environment.

About this task

Perform the following procedure:

Procedure

1. Perform an online change process for the IMS.MODBLKS data set on the IMS systems that have not migrated to DRD.
2. Issue **UPDATE** commands for the resource or descriptor definitions you want to update on the IMS systems that have DRD enabled.

Updating runtime MSC resource definitions with the UPDATE command

When dynamic resource definition (DRD) is enabled for MSC resources, you can update runtime MSC resources in an online IMS system by using the IMS type-2 **UPDATE** commands, **UPDATE MSLINK**, **UPDATE MSNAME**, and **UPDATE MSPLINK**.

Before you begin

You cannot update a resource if it is in use.

About this task

The resource definitions that you update by using the **UPDATE** commands are not saved across a cold start unless you export the definitions to the IMSRSC repository or code the changes to the MSC resources into stage-1 system definition macros.

To update runtime MSC resource definitions:

Procedure

1. Check for work in progress by using a **QRY LTERM**, **QRY MSLINK**, **QRY MSNAME**, or **QRY MSPLINK** command and either wait for the work to finish or address the work in progress.
2. Issue the **UPDATE** command for the type of MSC resource you want to update.

Related tasks

[Enabling the IMSRSC repository for MSC resources \(Communications and Connections\)](#)

Updating resource and descriptor definitions in the IMSRSC repository

You can update resource and descriptor definitions in the IMSRSC repository. Perform the procedure that applies to your specific scenario.

Related concepts

[“Overview of the IMSRSC repository” on page 37](#)

A repository is a generalized data storage facility that can be used to store any type of information. The IMS resource definition (IMSRSC) repository is a set of VSAM key sequenced data sets (KSDSs) used for storing information. The IMSRSC repository is a repository to store resource (and descriptor) definitions for IMS databases, transactions, programs, and routing codes. This repository is an alternative to the resource definition data set (RDDS) that is used with the dynamic resource definition (DRD) function.

[“Exporting MODBLKS resource and descriptor definitions to an IMSRSC repository” on page 81](#)

You can export resource and descriptor definitions from IMS to an IMSRSC repository by using the automatic export function or by issuing the `EXPORT DEFN TARGET(REPO)` command. You can export resource and descriptor definitions from the IMS system to the repository and have them defined for one or more new or existing IMS systems in your IMSplex.

Updating MODBLKS resource and descriptor definitions in the IMSRSC repository for a single IMS or for multiple IMSs with unique definitions

You can update MODBLKS resource and descriptor definitions in the IMSRSC repository for a single IMS system or for multiple IMS systems that each need a unique set of definitions.

Procedure

1. Update the resource and descriptor definitions in each IMS system by using the type-1 or type-2 DRD commands.

You can update descriptors by using the type-2 **UPDATE** command.

2. Export the resource and descriptor definitions from an IMS to the repository by using either the **EXPORT DEFN TARGET(REPO)** command or the automatic export function.

- In a non-cloned environment, the **EXPORT DEFN TARGET(REPO)** command must be issued to each IMS for which the resource definitions and descriptors are to be exported to the repository. Because the **EXPORT DEFN TARGET(REPO)** command is processed only by the command master IMS, a separate **EXPORT DEFN TARGET(REPO)** command must be issued to each IMS system. You can use the `ROUTE` keyword on the OM API to specify the IMS to which the command is routed. You do not have to specify the `SET(IMSID())` keyword, because IMS defaults the IMS ID to the command master IMS.

You can specify the **EXPORT DEFN TARGET(REPO)** command with `OPTION(CHANGESONLY)` to export resource and descriptor definitions that were either created or modified since they were last exported to the repository. Optionally you can use the **EXPORT DEFN TARGET(REPO)** command with a list of resource names and resource types specified, or use the **EXPORT DEFN TARGET(REPO)** command with the `STARTTIME` and `ENDTIME` keywords.

- To enable automatic export, specify `AUTOEXPORT=AUTO` or `AUTOEXPORT=REPO` in the `DYNAMIC_RESOURCES` section of the `DFSDfxxx` member in the IMS PROCLIB data set. Automatic export processing is done at the end of each IMS checkpoint. IMS automatically exports any changes in resource definitions for MODBLKS and MSC resources since the last automatic export or the **EXPORT DEFN TARGET(REPO)** command.

Related concepts

[“Overview of the IMSRSC repository” on page 37](#)

A repository is a generalized data storage facility that can be used to store any type of information. The IMS resource definition (IMSRSC) repository is a set of VSAM key sequenced data sets (KSDSs) used for storing information. The IMSRSC repository is a repository to store resource (and descriptor) definitions

for IMS databases, transactions, programs, and routing codes. This repository is an alternative to the resource definition data set (RDDS) that is used with the dynamic resource definition (DRD) function.

Related reference

[EXPORT command \(Commands\)](#)

Updating MODBLKS resource and descriptor definitions in the IMSRSC repository for multiple IMS systems with the same set of definitions

You can update MODBLKS resource and descriptor definitions in the IMSRSC repository for multiple IMS systems with the same set of definitions.

Procedure

1. Update the resource and descriptor definitions in the IMS system by using the type-1 or type-2 DRD commands.

You can update descriptors only with the type-2 **UPDATE** command.

2. Export the resource and descriptor definitions from an IMS to the repository by using the **EXPORT DEFN TARGET(REPO)** command.

You must route the command to the IMS system from which you want to export the definitions and descriptors, by using the ROUTE keyword on the OM API. The *imsidlist* is the list of IMS IDs of one or more IMS systems in the IMSplex to which the changes are to be applied.

You can specify the **EXPORT DEFN TARGET(REPO)** command with the keywords **OPTION(CHANGESONLY) SET(IMSID(*imsidlist*))** to export resource and descriptor definitions that were created or modified since they were last exported to the repository. Optionally you can use the **EXPORT DEFN TARGET(REPO)** command with a list of resource names and resource types specified, or use the **EXPORT DEFN TARGET(REPO)** command with the STARTTIME and ENDTIME keywords.

Related concepts

[“Overview of the IMSRSC repository” on page 37](#)

A repository is a generalized data storage facility that can be used to store any type of information. The IMS resource definition (IMSRSC) repository is a set of VSAM key sequenced data sets (KSDSs) used for storing information. The IMSRSC repository is a repository to store resource (and descriptor) definitions for IMS databases, transactions, programs, and routing codes. This repository is an alternative to the resource definition data set (RDDS) that is used with the dynamic resource definition (DRD) function.

[“Updating runtime resource and descriptor definitions” on page 61](#)

When dynamic resource definition (DRD) is enabled, you can update runtime resource and descriptor definitions dynamically, eliminating the need to use the online change process or to cold start IMS. Although the overall process for updating runtime database, application program, transaction, routing code, MSC physical link, MSC logical link, MSC MSNAME, and MSC remote LTERM definitions is the same, there are minor variations in the steps you complete.

[“Exporting MODBLKS resource and descriptor definitions to an IMSRSC repository” on page 81](#)

You can export resource and descriptor definitions from IMS to an IMSRSC repository by using the automatic export function or by issuing the **EXPORT DEFN TARGET(REPO)** command. You can export resource and descriptor definitions from the IMS system to the repository and have them defined for one or more new or existing IMS systems in your IMSplex.

Related reference

[EXPORT command \(Commands\)](#)

Updating MSC resource definitions in the IMSRSC repository

You can update MSC resource definitions for one or more new or existing IMS systems in your IMSplex by using the IMS type-2 **UPDATE** commands. The updated MSC resource definitions can then be automatically exported to the IMSRSC repository.

Before you begin

Before you update MSC resource definitions by using the **UPDATE** commands, ensure that the following prerequisites are met:

- The IMSRSC repository is defined.
- Dynamic resource definition for MSC resources is enabled.
- The IMSRSC repository is enabled for MSC resources.
- AUTOEXPORT=AUTO or REPO is specified in the DYNAMIC_RESOURCES section of the DFSDFxxx member of the IMS PROCLIB member.
- MODBLKS=DYN is specified either in the COMMON_SERVICE_LAYER section of the DFSDFxxx PROCLIB member or in the DFSCGxxx member of the IMS PROCLIB data set.

Procedure

Update MSC resources such as definitions for MSC physical links, logical links, and logical link paths by using the appropriate **UPDATE** command for the type of resource definition that you want to update.

The **UPDATE** command must be issued to each IMS in each IMSplex for which the resource definitions are to be exported to the repository. You can use the ROUTE keyword on the OM API to specify the IMS to which the command is routed.

After an MSC resource definition is updated, the resource is automatically exported to the IMSRSC repository at the next IMS checkpoint. The IMS checkpoint can be initiated with the **/CHECKPOINT** command, or the **/CHECKPOINT FREEZE** command, or automatically by the IMS system.

If you use the **/CHECKPOINT** command to initiate an IMS checkpoint, the command must be routed to each IMS in each IMSplex in which the MSC resources are defined.

Related tasks

[Enabling the IMSRSC repository for MSC resources \(Communications and Connections\)](#)

[Enabling dynamic definition for MSC resources \(System Definition\)](#)

[Defining the IMSRSC repository \(System Definition\)](#)

Related reference

[UPDATE MSLINK command \(Commands\)](#)

[UPDATE MSNAME command \(Commands\)](#)

[UPDATE MSPLINK command \(Commands\)](#)

[/CHECKPOINT command \(Commands\)](#)

Deleting runtime resource and descriptor definitions

When dynamic resource definition (DRD) is enabled, you can use the DELETE command to delete runtime resource and descriptor definitions dynamically, eliminating the requirement to use the online change process or to cold start IMS. Although the overall process for deleting runtime database, application program, transaction, routing code, MSC physical link, MSC logical link, MSC MSNAME, and MSC remote LTERM definitions is the same, there are minor variations in the steps you complete.

The resource and descriptor definitions that you delete dynamically using the DELETE command remain deleted across a warm or emergency restart.

Each resource or descriptor definition is deleted individually, unlike the online change process, where either all resources or descriptor definitions are deleted or no resources or descriptor definitions are deleted.

Deleting runtime resource and descriptor definitions when using an IMSRSC repository

To delete runtime resource and descriptor definitions from IMS and from the IMSRSC repository, perform the following procedure:

1. Issue the DELETE command locally at each IMS that contains the runtime definitions.

If definitions of more than one type are being deleted, issue multiple different DELETE commands (according to the type of resource or descriptor definitions you want to delete).

2. Issue the DELETE DEFN command to delete the definitions from the repository.

Issuing the command ensures that the definitions remain deleted in IMS across a cold start, and that they are not imported from the repository during cold start processing or with the IMPORT DEFN command.

If using an XRF (Extended Recovery Facility) configuration, issue the DELETE DEFN command with the IMS IDs of both the active and alternate system on the FOR(IMSID()) keyword.

The transactions and routing codes must be deleted before the programs can be deleted.

All the definitions for the names specified on the DELETE DEFN command are deleted as a single unit of work.

Recommendation: When a resource definition is being deleted in the IMSplex, delete the runtime resource first and then delete it from the repository.

Unlike the process for deleting runtime resource and descriptor definitions when using an RDDS, issuing the EXPORT command does not ensure that the resources remain deleted in IMS across a cold start.

Deleting runtime resource and descriptor definitions when using an RDDS

To delete runtime resource and descriptor definitions from IMS and from an RDDS, perform the following procedure:

1. Issue the DELETE command locally at each IMS that contains the runtime definitions.

If definitions of more than one type are being deleted, issue multiple different DELETE commands (according to the type of resource or descriptor definitions you want to delete).

If you have set up automatic export to an RDDS, automatic export occurs at system checkpoint and removes the deleted definitions from the system RDDS.

2. If you have not set up automatic export to an RDDS, issue the EXPORT command at each IMS from which the definitions were deleted to ensure the removal of deleted definitions from the system RDDS (or non-system RDDS).

You can then import the resource and descriptor definitions from the RDDS back into IMS in one of the following ways:

- During cold start processing by using the automatic import function.
- After IMS is up and running by using the IMPORT DEFN command.

Restrictions

You cannot delete a runtime resource definition if the resource is in use. Examples of resources in use include:

- A database that is being accessed by an application program
- A database that is referenced by the program specification block (PSB) for an existing program
- A /STOP or UPDATE command that is in progress for the resource
- An application program that is scheduled to run
- An active routing code

- A transaction with messages queued for it
- A transaction that has any work in progress
- An MSC physical link, logical link, or logical link path (MSNAME) that is not stopped
- An MSC remote LTERM that is not stopped
- An MSC physical link that is referenced by an MSC logical link
- An MSC logical link that is referenced by an MSC MSNAME
- An MSC MSNAME that is referenced by an MSC remote LTERM

If you attempt to delete a resource that is in use, the delete attempt fails. In a sysplex environment, the delete attempt might succeed on some IMS systems and fail on others.

You cannot delete the following resources that are supplied by IMS: DBFDSRT1, DFSDSDB1, DFSDSPG1, DFSDSTR1, and DBF#FPU0.

You cannot delete a HALDB master database resource unless it has no partitions defined and you have issued a /DBRECOVERY command for the database.

Related concepts

[“Overview of the IMSRSC repository” on page 37](#)

A repository is a generalized data storage facility that can be used to store any type of information. The IMS resource definition (IMSRSC) repository is a set of VSAM key sequenced data sets (KSDSs) used for storing information. The IMSRSC repository is a repository to store resource (and descriptor) definitions for IMS databases, transactions, programs, and routing codes. This repository is an alternative to the resource definition data set (RDDS) that is used with the dynamic resource definition (DRD) function.

[Recovery during the IMSRSC repository data set update process \(Operations and Automation\)](#)

Related tasks

[“Deleting resource and descriptor definitions from the IMSRSC repository” on page 76](#)

To delete resource and descriptor definitions from the IMSRSC repository, issue the **DELETE DEFN** command.

Related reference

[DELETE DEFN command \(Commands\)](#)

[IMPORT DEFN SOURCE\(REPO | RDDS\) command \(Commands\)](#)

[DELETE commands \(Commands\)](#)

Deleting runtime database resource and descriptor definitions with the DELETE command

With dynamic resource definition (DRD) enabled, you can delete runtime resource and resource descriptors dynamically, eliminating the need to use the online change process or the batch system definition process with an IMS cold start.

About this task

Delete runtime database resource and descriptor definitions using the DELETE DB and DELETE DBDESC commands.

Procedure

1. Check for work in progress with a **QRY DB SHOW(WORK)** command. If there is work in progress, either:
 - Wait for the work to finish.
 - Address the work in progress.
2. Determine whether any application programs reference the database by issuing a **QRY DB SHOW(PGM)** command. The **DELETE DB** command fails if any programs reference the database. If a program references the database, before deleting the database, you must either:

- Delete the programs that reference the database. If you decide to delete the programs that reference the database, and if there are transactions or routing codes that reference the programs, they must be deleted first.
 - Perform an online change to delete the PSB from ACBLIB.
 - Update the PSB so that it does not reference the database.
3. The next step varies depending on whether the resource to be deleted is a database with secondary or logical relationships, an MSDB, or a HALDB master database.
- If the resource to be deleted is a database with secondary indexes or logical relationships, remove the relationships by performing these steps:
 - a. Update the database description (DBD) to remove the relationships.
 - b. Run the Database Description Generation (DBDGEN) utility.
 - c. Run the Application Control Block (ACB) Maintenance utility.
 - d. Bring the updated DBDs and ACBs online using an online change process.
 - If the resource to be deleted is a main storage database (MSDB), perform these steps:
 - a. Use the MSDB Maintenance utility (DBFDBMA0) to remove segments from the MSDBINIT data set.
 - b. Delete the MSDB from any PSB that references it using the DELETE DBD= action control statement of DBFDBMA0.
 - c. Perform a PSBGEN for the PSB that was modified.
 - d. Perform an ACBGEN for the PSB that was modified.
 - e. Perform an ACBGEN for the DBD of the MSDB that was deleted from the PSB.
 - f. Either change or remove the appropriate DBFMSDBx procedure that is in the IMS.PROCLIB data set.
 - g. Shut down IMS normally using the **/CHE FREEZE** command.
 - h. Copy the above ACBLIB to both the active and inactive ACBLIB.
 - i. Normally restart IMS using the **/NRE** command specified with the MSDBLOAD keyword to refresh the MSDBs.
 - If the resource to be deleted is a HALDB master database, perform these steps:
 - a. Issue a **/DBRECOVERY** command.

The **/DBRECOVERY** command removes this IMS system's knowledge of the HALDB partitions and stops the HALDB master database so that it can be deleted.
4. Stop the database using either a **/DBR DB** or an **UPDATE DB STOP(ACCESS)** command.
- A database must be successfully stopped by **/DBR** command before it can be deleted. Because the MSDB is no longer in the ACBLIB, IMS does not know that the database was previously an MSDB and allows the **/DBR** command.
5. Issue the **DELETE DB** or **DELETE DBDESC** command to delete the database resource or descriptor definition, respectively.

Deleting runtime application program resource and descriptor definitions with the DELETE command

With dynamic resource definition (DRD) enabled, you can delete runtime application program resources and resource descriptors dynamically, eliminating the need to use the online change process or the batch system definition process with an IMS cold start.

About this task

Delete runtime application program resource and descriptor definitions using the DELETE PGM and DELETE PGMDESC commands.

Procedure

1. Check for work in progress with a **QRY PGM SHOW(WORK)** command. If there is work in progress, either:
 - a) Wait for the work to finish.
 - b) Address the work in progress.
2. Determine whether any transactions reference the program by using a **QRY PGM SHOW(TRAN)** command. The **DELETE PGM** command fails if any transactions reference the program. If a transaction references the program, before deleting the program you must either:
 - Delete the transactions that reference the program by issuing a **DELETE TRAN** command.
 - Update the transactions to reference a different program by using the **UPDATE PGM** command.
3. Determine whether any routing codes reference the program by using a **QRY PGM SHOW(RTC)** command. The **DELETE PGM** command fails if any routing codes reference the program. If a routing code references the program, before deleting the program you must either:
 - Delete the routing codes that reference the program.
To delete a routing code associated with a Fast Path exclusive FP(E) transaction, issue a **DELETE TRAN** command.
To delete a routing code associated with a Fast Path potential FP(P) transaction, issue a **DELETE RTC** command.
 - Update the routing code to reference a different program using the **UPDATE RTC** command.
To update a routing code associated with an FP(E) transaction, issue an **UPDATE TRAN** command.
To update a routing code associated with an FP(P) transaction, issue an **UPDATE RTC** command.
4. The next step varies depending on where the application program is running.
 - If the program is running in an IFP region or is a BMP processing a WFI transaction, issue a **/STOP REGION** command to terminate the program.
 - If the program is running in a BMP or JBP region, either:
 - a. Wait for the program to finish.
 - b. Issue a **/STOP REGION** command to terminate the program.
 - If the program is running in an MPP or JMP region, issue a **/STOP PGM** or **UPDATE PGM STOP(SCHD)** command to terminate the program.
5. Issue the **DELETE PGM** or **DELETE PGMDESC** command to delete the application program resource or descriptor definition, respectively.

Deleting runtime Fast Path routing code resource and descriptor definitions with the DELETE command

With dynamic resource definition (DRD) enabled, you can delete runtime Fast Path routing code resource and descriptor definitions dynamically, eliminating the need to use the online change process or the batch system definition process with an IMS cold start.

About this task

Delete runtime Fast Path routing code resources and descriptor definitions using the **DELETE RTC** and **DELETE RTCDESC** commands.

Procedure

1. Check for work in progress by issuing a **QRY RTC SHOW(WORK)** command. If there is work in progress, either:
 - Wait for the work to finish.

- Address the work in progress.
2. The next step can vary based on whether the transaction is associated with a Fast Path potential FP(P) or Fast Path exclusive FP(E) transaction.
 - Delete a routing code that is associated with a Fast Path potential transaction using the **DELETE RTC** command. If the program is scheduled, the routing code cannot be deleted and you must stop the region before you issue the **DELETE RTC** command.
 - Delete a routing code that is associated with a Fast Path exclusive transaction using the **DELETE TRAN** command. The **DELETE RTC** command fails.
 - Delete a runtime routing code descriptor definition by issuing the **DELETE RTCDESC** command.
 3. If you are using the IMSRSC repository to store your Fast Path routing code resource and descriptor definitions, issue **DELETE DEFN** commands to delete them from the repository.

The routing codes associated with both FP(P) and FP(E) transactions are maintained in the repository.

Use the **DELETE DEFN** command to delete routing codes referenced by FP(P) transactions. Then issue **DELETE DEFN** commands to delete FP(P) transactions and FP(E) transactions. When an FP(E) transaction is deleted from the repository by using the **DELETE DEFN** command, the routing code associated with the FP(E) transaction is also deleted from the repository by RM.

Related concepts

[“Overview of the IMSRSC repository” on page 37](#)

A repository is a generalized data storage facility that can be used to store any type of information. The IMS resource definition (IMSRSC) repository is a set of VSAM key sequenced data sets (KSDSs) used for storing information. The IMSRSC repository is a repository to store resource (and descriptor) definitions for IMS databases, transactions, programs, and routing codes. This repository is an alternative to the resource definition data set (RDDS) that is used with the dynamic resource definition (DRD) function.

Deleting runtime transaction resource and descriptor definitions with the DELETE command

With dynamic resource definition (DRD) enabled, you can delete runtime resource and resource descriptors dynamically, eliminating the need to use the online change process or the batch system definition process with an IMS cold start.

About this task

Delete runtime transaction resource and descriptor definitions using the **DELETE TRAN** and **DELETE TRANDESC** commands.

Procedure

1. Check for work in progress with a **QRY TRAN SHOW(WORK)** command and either:
 - Wait for the work to finish.
 - Address the work in progress.

Examples of work include a command in progress for the transaction, or the transaction is either scheduled, in conversation, or suspended.

2. To wait for the work in progress to complete, issue either a **/PURGE TRAN** or **UPDATE TRAN STOP(Q)** command to stop the transaction from being queued, but to allow existing queued messages to be processed.
3. If you do not want to wait for the work in progress to complete, or if the transaction is a WFI transaction, stop the transaction by using a **/STOP TRAN** or **UPDATE TRAN STOP(SCH,Q)** command.

If you are stopping the transaction in a non-shared queues environment, no messages can be queued for the transaction. To dequeue messages for the transaction, issue the **QUEUE TRAN OPTION(DEQALL)** command.

4. The next step can vary depending on where the transaction is running.
 - If the transaction is running in a PWFI=Y MPP region, stop the transaction by using a **/STOP TRAN** or **UPDATE TRAN STOP(SCHD,Q)** command. If you are stopping the transaction in a non-shared queues environment, no messages can be queued for the transaction. To dequeue messages for the transaction, issue the **QUEUE TRAN OPTION(DEQALL)** command.
 - If the transaction is running in an IFP region, terminate the program by issuing a **/STOP REGION** command.
 - If the transaction is a non-WFI transaction running in a message-driven BMP, either wait for the program to finish, or terminate the program by issuing a **/STOP REGION** command.
 - If the transaction is a WFI transaction running in a message-driven BMP, terminate the program by issuing a **/STOP REGION** command.
5. If the transaction has messages on the suspend queue and you are running in a non-shared queues environment, you must either process the messages on the suspend queue or delete the messages. To delete the messages on the suspend queue:
 - a) Stop the transaction by issuing a **/STOP TRAN** or **UPDATE TRAN STOP(SCHD)** command.
 - b) Move the messages to the ready queue by issuing a **/DEQ SUSPEND** or **UPDATE TRAN START(SUSPEND)** command.
 - c) After the messages are on the ready queue, delete them by issuing a **QUEUE TRAN OPTION(DEQALL)** command.
6. Issue the **DELETE TRAN** or **DELETE TRANDESC** command to delete the transaction resource or descriptor definition, respectively.

Deleting runtime resource and descriptor definitions in an IMSplex with the DELETE command

If you have a mixture of DRD-enabled and DRD-disabled IMS systems in an IMSplex, you can delete resource or descriptor definitions for this environment.

About this task

Perform the following procedure:

Procedure

1. Perform an online change process for the IMS.MODBLKS data set on the IMS systems that have not migrated to DRD.
2. Issue **DELETE** commands for the resource or descriptor definitions you want to delete on the IMS systems that have DRD enabled.

Deleting runtime MSC resource definitions with the DELETE command

When dynamic resource definition (DRD) is enabled, you can use the **DELETE** command to delete runtime MSC resource definitions such as MSC physical links, MSC logical links, MSC MSNAMEs, and MSC remote LTERMs.

About this task

The MSC resource definitions that you delete dynamically using the **DELETE** command remain deleted across a warm or emergency restart.

If you are deleting an MSC resource that is stored in the IMSRSC repository, use the **DELETE DEFN** command to delete the resource from the repository.

Restriction: You cannot delete a runtime resource definition if it is in use. Examples of resources in use include:

- An MSC physical link, logical link, or logical link path (MSNAME) that is not stopped
- An MSC remote LTERM that is not stopped
- An MSC physical link that is referenced by an MSC logical link
- An MSC logical link that is referenced by an MSC MSNAME
- An MSC MSNAME that is referenced by an MSC remote LTERM

To delete MSC resource definitions:

Procedure

1. Check for work in progress by using a **QRY LTERM**, **QRY MSLINK**, **QRY MSNAME**, or **QRY MSPLINK** command and either wait for the work to finish or address the work in progress.
2. Issue the **DELETE** command for the type of MSC resource you want to delete. MSC resources must be deleted in the following order: **DELETE LTERM**, **DELETE MSNAME**, **DELETE MSLINK**, **DELETE MSPLINK**.

DELETE MSPLINK is rejected if any logical link references it. **DELETE MSLINK** is rejected if any logical link path (MSNAME) references it. **DELETE MSNAME** is rejected if any LTERM references it, or if any remote transaction has its system ID (SYSID) values.

Related tasks

[“Deleting resource and descriptor definitions from the IMSRSC repository” on page 76](#)

To delete resource and descriptor definitions from the IMSRSC repository, issue the **DELETE DEFN** command.

Deleting resource and descriptor definitions from the IMSRSC repository

To delete resource and descriptor definitions from the IMSRSC repository, issue the **DELETE DEFN** command.

About this task

Recommendation: When a resource definition is being deleted in the IMSplex, delete the runtime resource first and then delete it from the repository.

Issuing the **DELETE DEFN** command ensures that the definitions remain deleted in IMS across a cold start, and that they are not imported from the repository during cold start processing or with the **IMPORT DEFN** command.

If you delete MSC resource definitions from the IMSRSC repository, delete the definitions in the following order:

1. Remote transaction definitions
2. Remote logical terminal (LTERM) definitions
3. MSC logical link paths (MSNAMEs)
4. MSC logical links (MSLINKs)
5. MSC physical links (MSPLINKs)

Related concepts

[“Overview of the IMSRSC repository” on page 37](#)

A repository is a generalized data storage facility that can be used to store any type of information. The IMS resource definition (IMSRSC) repository is a set of VSAM key sequenced data sets (KSDSs) used for storing information. The IMSRSC repository is a repository to store resource (and descriptor) definitions for IMS databases, transactions, programs, and routing codes. This repository is an alternative to the resource definition data set (RDDS) that is used with the dynamic resource definition (DRD) function.

[“Deleting runtime resource and descriptor definitions” on page 69](#)

When dynamic resource definition (DRD) is enabled, you can use the DELETE command to delete runtime resource and descriptor definitions dynamically, eliminating the requirement to use the online change process or to cold start IMS. Although the overall process for deleting runtime database, application program, transaction, routing code, MSC physical link, MSC logical link, MSC MSNAME, and MSC remote LTERM definitions is the same, there are minor variations in the steps you complete.

Related reference

[DELETE DEFN command \(Commands\)](#)

Backing out DRD command-related changes made to your online system

You can back out DRD command-related resource changes to your online system both with and without a cold start of IMS.

About this task

Related tasks

[Cold starting an IMS system that uses an RDDS \(Operations and Automation\)](#)

Backing out DRD command-related changes to your online system with a cold start of IMS

You can back out dynamic resource definition (DRD) command-related resource changes to your online system with a cold start of IMS.

Before you begin

Prerequisites: Before you make changes to your system, use the **EXPORT DEFN** command to either export all the resource and descriptor definitions to a non-system resource definition data set (RDDS) or export the resource and descriptor definitions that are to be changed or deleted to the IMSRSC repository. Then, issue **CREATE**, **UPDATE**, and **DELETE** commands to create new resource definitions, update existing resource definitions, and delete existing resource definitions. If resource definitions were exported to the repository by the **EXPORT DEFN** command or an automatic export to the repository and they need to be modified, issue another **EXPORT** command after a **CREATE** or **UPDATE** command is issued in IMS. If you issued **DELETE** commands in IMS, issue the **DELETE DEFN** command to delete the resource definition from the repository for the IMS system.

About this task

To back out changes:

Procedure

1. Cold start IMS with no MODBLKS resources defined (by specifying AUTOIMPORT=N in the Dynamic Resources section of the DFSDFxxx IMS PROCLIB member).
2. Issue the **IMPORT DEFN** command to import all of the stored resource and descriptor definitions from the non-system RDDS or all of the resource and descriptor definitions for the IMS system from the repository.

What to do next

After the backout is complete, if you are running with system RDDSs defined, issue the **EXPORT DEFN TARGET (RDDS)** command to export the current definitions to a system RDDS.

Related tasks

[Cold starting an IMS system that uses an RDDS \(Operations and Automation\)](#)

Backing out DRD command-related changes to your online system without a cold start of IMS

You can back out dynamic resource definition (DRD) command-related resource changes to your online system without a cold start of IMS.

Before you begin

Before you make changes to your system, use the **EXPORT DEFN** command to export the resource and descriptor definitions that are to be changed or deleted to either a non-system resource definition data set (RDDS) or to the IMSRSC repository. Then, issue **CREATE**, **UPDATE**, and **DELETE** commands to create new resource definitions, update existing resource definitions, and delete existing resource definitions. If resource definitions were exported to the repository by the **EXPORT DEFN** command or an automatic export to the repository and they need to be modified, issue another **EXPORT** command after a **CREATE** or **UPDATE** command is issued in IMS. If you issued **DELETE** commands in IMS, issue the **DELETE DEFN** command to delete the resource definition from the repository for the IMS system.

Tip: Keep a list of the resources that are changed, updated, and deleted, in case a backout of the changes is needed.

About this task

To back out changes:

Procedure

1. Issue **DELETE** commands for any resource and descriptor definitions that were newly created.
2. Issue the **IMPORT DEFN** command with **OPTION(UPDATE)** to import (from either the non-system RDDS or the repository) the stored definitions for any resource and descriptor definitions that were updated or deleted. The **IMPORT DEFN** command creates any resource and descriptor definitions that were deleted and replaces any resource and descriptor definitions that were updated.

What to do next

After the backout is complete, if you are running with system RDDSs defined, issue the **EXPORT DEFN TARGET(RDDS)** command to export the current definitions to a system RDDS.

Related reference

[DELETE commands \(Commands\)](#)

[EXPORT command \(Commands\)](#)

[IMPORT DEFN SOURCE\(REPO | RDDS\) command \(Commands\)](#)

Backing out MSC DRD command-related changes to your online system

You can back out the changes that were dynamically made to your runtime MSC resources with a cold start of IMS.

Before you begin

Prerequisites: Before you make changes to your system, ensure that all of the following prerequisites are met:

- The IMSRSC repository is defined.
- **REPOSITORY=(TYPE=IMSRSC)** is specified in the **REPOSITORY** section of the **DFSDFxxx** proclib member to enable the IMSRSC repository.
- **MSCREPO=Y** is specified in the **MSC** section of the **DFSDFxxx** member of the **IMS PROCLIB** data set to enable the IMSRSC repository for MSC resources.
- **AUTOEXPORT=AUTO** or **AUTOEXPORT=REPO** is specified in the **DYNAMIC_RESOURCES** section of the **DFSDFxxx** **PROCLIB** member to enable automatic export to the IMSRSC repository.

- AUTOIMPORT=AUTO or AUTOIMPORT=REPO is specified in the DYNAMIC_RESOURCES section of the DFSDFxxx PROCLIB member to enable automatic import to the IMSRSC repository.

About this task

To back out changes:

Procedure

1. Export all of the runtime MSC resource definitions to the IMSRSC repository by using the automatic export function. Then, issue **CREATE**, **UPDATE**, and **DELETE** commands to create new resource definitions, update existing resource definitions, and delete existing resource definitions. If resource definitions were exported to the repository and they need to be modified, export the definitions again after a **CREATE** or **UPDATE** command is issued in IMS. If you issued **DELETE** commands in IMS, issue the **DELETE DEFN** command to delete the resource definition from the repository for the IMS system.
2. Cold start IMS.

At cold start, the MSC resources are imported from the IMSRSC repository.

Related tasks

[“Exporting MSC resource definitions to an IMSRSC repository” on page 83](#)

You can export MSC resource definitions from IMS to an IMSRSC repository by using the automatic export function and have the resources defined for one or more new or existing IMS systems in your IMSplex.

[“Defining the IMSRSC repository” on page 40](#)

Before you can use the IMSRSC repository to store and retrieve resource and descriptor definitions, you must define it. In addition, IMS and the Resource Manager (RM) must have the repository enabled, the Repository Server (RS) must be started and active, and the repository must be started.

Related reference

[“MSC section of the DFSDFxxx member” on page 797](#)

The MSC section of the DFSDFxxx member of the IMS PROCLIB data set specifies options for the Multiple Systems Coupling (MSC) function of IMS. The section header must be specified as <SECTION=MSC>. The MSC section is valid in DB/DC and DCCTL environments.

[“DYNAMIC_RESOURCES section of the DFSDFxxx member” on page 780](#)

The DYNAMIC_RESOURCES section of the DFSDFxxx member specifies options for import and export, log write ahead, and system resource definition data sets. This section is processed only if DRD is enabled (MODBLKS=DYN). If DRD is not enabled, this section is ignored. The section is defined by the header <SECTION=DYNAMIC_RESOURCES>. The DYNAMIC_RESOURCES section is valid in DB/DC, DBCTL, and DCCTL environments.

[“REPOSITORY section of the DFSDFxxx member” on page 805](#)

The REPOSITORY section of the DFSDFxxx member specifies the repository types that are to be enabled at IMS. The valid type is: IMSRSC repository, which is used to store the stored resource definitions for DRD resources. The section must begin with the header <SECTION=REPOSITORY>. The REPOSITORY section is valid in DB/DC, DBCTL, and DCCTL environments.

Exporting resource and descriptor definitions

When resource and descriptor definitions are ready to be created in a resource definition data set (RDDS) or an IMSRSC repository as the stored resource and descriptor definitions, you can export them to the RDDS or the repository.

About this task

Related concepts

[“Overview of the IMSRSC repository” on page 37](#)

A repository is a generalized data storage facility that can be used to store any type of information. The IMS resource definition (IMSRSC) repository is a set of VSAM key sequenced data sets (KSDSs) used for storing information. The IMSRSC repository is a repository to store resource (and descriptor) definitions

for IMS databases, transactions, programs, and routing codes. This repository is an alternative to the resource definition data set (RDDS) that is used with the dynamic resource definition (DRD) function.

[“Managing resource and descriptor definitions” on page 31](#)

With dynamic resource definition (DRD) enabled, you can perform several tasks to manage the resource and descriptor definitions for your IMS system.

[“Resource lists for the IMSRSC repository” on page 42](#)

In addition to stored resource definitions and resource descriptors, the IMSRSC repository also contains resource lists.

[“Change lists for the IMSRSC repository” on page 43](#)

IMS warm or emergency restart processes the IMS log to build runtime resource definitions. After the log is processed, if IMS is enabled to use the IMSRSC repository, IMS calls Resource Manager (RM) to read any change list for the IMS.

Related reference

[EXPORT command \(Commands\)](#)

Exporting MODBLKS resource and descriptor definitions to an RDDS

Use the automatic export function or the EXPORT DEFN TARGET(RDDS) command to save your current MODBLKS resource and descriptor definitions to a resource definition data set (RDDS).

- When exporting to a system RDDS, all the IMS MODBLKS resource and descriptor definitions must be exported. All definitions in the system RDDS are overwritten with the definitions being exported.
- When exporting to a non-system RDDS, all or some of the IMS MODBLKS resource and descriptor definitions can be exported. You can either overwrite the existing definitions with the new definitions or append the new definitions to the end of the data set.
- Definitions for IMS resources such as the Fast Path utility (DBF#FPU0) and the IMS defined descriptors (DBFDSRT1, DFSDSDB1, DFSDSPG1, and DFSDSTR1) cannot be exported.

Exporting MODBLKS resource and descriptor definitions with automatic export

Perform the following procedure to set up automatic export of MODBLKS resource and descriptor definitions to an RDDS:

1. Define two or more system resource definition data sets to IMS by using the RDDSDSN() parameter in the DYNAMIC_RESOURCES section of the DFSDFxxx member in the IMS PROCLIB data set.

If you are using automatic import or automatic export, each IMS system must have its own set of system RDDSs.
2. Specify AUTOEXPORT=AUTO or AUTOEXPORT=RDDS in the DYNAMIC_RESOURCES section in the DFSDFxxx member of the IMS PROCLIB data set.

Resource and descriptor definitions are exported to the oldest RDDS at checkpoint time if the definitional attributes of one or more resources has changed since the last checkpoint.

XRF considerations:

An XRF active and alternate can be enabled to use autoexport to the IMSRSC repository. The active and alternate must explicitly specify AUTOEXPORT=AUTO or REPO in the DFSDFxxx member. The AUTOEXPORT= and AUTOEXPORT_IMSID= values in the DFSDFxxx members at the active and alternate must be the same because IMS does not validate that the same value is specified for the active and alternate. If they are different, the results are unpredictable.

When AUTOEXPORT_IMSID=THIS_IMS is specified in the DFSDFxxx member, the XRF active and the XRF alternate write the resource definition changes to the repository. When AUTOEXPORT_IMSID=ALL is specified in the DFSDFxxx member and the XRF alternate is defined to the repository, the XRF active writes the resource definition changes to the repository for the XRF alternate as well. The XRF alternate also tries to write the resource definition changes, but because the changes are already in the repository, the write is treated as successful (even though no physical write to the IMSRSC repository is made).

No X'22' map byte X'51' autoexport log record is written on the XRF alternate, because no logger services are available on the XRF alternate.

Exporting MODBLKS resource and descriptor definitions with the EXPORT command

Use the EXPORT DEFN TARGET(RDDS) command to export MODBLKS resource and descriptor definitions to an RDDS.

MODBLKS resource and descriptor definitions are either written to the data set specified by the RDDSdsn() command keyword, or to the system RDDS containing the oldest data. A system RDDS is one of the RDDS data sets that is defined with the RDDSdsn= parameter in the DYNAMIC_RESOURCES section of the DFSDfxxx member of the IMS PROCLIB data set. A system RDDS contains all the MODBLKS resource and descriptor definitions for a single IMS system.

Related concepts

[“Overview of the IMSRSC repository” on page 37](#)

A repository is a generalized data storage facility that can be used to store any type of information. The IMS resource definition (IMSRSC) repository is a set of VSAM key sequenced data sets (KSDSs) used for storing information. The IMSRSC repository is a repository to store resource (and descriptor) definitions for IMS databases, transactions, programs, and routing codes. This repository is an alternative to the resource definition data set (RDDS) that is used with the dynamic resource definition (DRD) function.

[Shutting down an IMS system that uses dynamic resource definition \(Operations and Automation\)](#)

Related reference

[“DYNAMIC_RESOURCES section of the DFSDfxxx member” on page 780](#)

The DYNAMIC_RESOURCES section of the DFSDfxxx member specifies options for import and export, log write ahead, and system resource definition data sets. This section is processed only if DRD is enabled (MODBLKS=DYN). If DRD is not enabled, this section is ignored. The section is defined by the header <SECTION=DYNAMIC_RESOURCES>. The DYNAMIC_RESOURCES section is valid in DB/DC, DBCTL, and DCCTL environments.

[EXPORT command \(Commands\)](#)

Exporting MODBLKS resource and descriptor definitions to an IMSRSC repository

You can export resource and descriptor definitions from IMS to an IMSRSC repository by using the automatic export function or by issuing the EXPORT DEFN TARGET(REPO) command. You can export resource and descriptor definitions from the IMS system to the repository and have them defined for one or more new or existing IMS systems in your IMSplex.

Alternatively, you can use the RDDS to Repository utility (CSLURP10) to write resource and descriptor definitions from a specified RDDS (instead of exporting from IMS) to the repository.

Before exporting resource and descriptor definitions to the repository, enable the IMSplex to use dynamic resource definition (DRD) with a repository.

To check for and identify which resource and descriptor definitions have not yet been exported to the repository, issue the **QUERY rsc_type SHOW(EXPORTNEEDED)** command, where *rsc_type* can be one of the following resources and resource descriptors: DB, DBDESC, PGM, PGMDESC, RTC, RTCDESC, TRAN, or TRANDESC.

The exported resource and descriptor definitions overwrite the existing definitions in the repository for the IMS. If the **EXPORT** command or the CSLURP10 utility is issued with SET(IMSID(*imsidlist*)), the resource definitions for the IMS IDs in the IMS list are updated with the specified resource definitions. If the **EXPORT** command or the CSLURP10 utility is issued with SET(IMSID(*)), the resource definitions for all IMS systems are overwritten with the specified definitions.

Definitions for IMS resources such as the Fast Path utility (DBF#FPU0) and the IMS defined descriptors (DBFDSRT1, DFSDSDB1, DFSDSPG1, and DFSDSTR1) cannot be exported.

Exporting resource and descriptor definitions with automatic export

If IMS is enabled with the IMSRSC repository and AUTOEXPORT=AUTO or REPO is specified in the DFSDFxxx PROCLIB member, IMS will automatically export any changes in resource definitions for MODBLKS resources since the last automatic export or the **EXPORT DEFN TARGET(REPO)** command to the repository. Automatic export to the IMSRSC repository processing is done at the end of an IMS checkpoint for a normal checkpoint and before the IMS shutdown checkpoint. Any newly created or updated resources or descriptors since the last successful export are exported to the repository.

At a normal checkpoint, the newly created or modified resources will be marked in the IMS checkpoint log record as "export needed". At the end of the automatic export to the repository, a new X'22' automatic export completed log record will be written.

For any errors during automatic export that was triggered by a normal checkpoint processing, you can issue the **QUERY rsc_type SHOW(EXPORTNEEDED)** command to see if any resource or descriptor definitions need to be exported. *rsc_type* can be one of the following resources and resource descriptors: DB, DBDESC, PGM, PGMDESC, RTC, RTCDESC, TRAN, or TRANDESC. Then, you can issue an **EXPORT DEFN OPTION(CHANGESONLY)** command or wait for the next automatic export.

If the automatic export is triggered at all IMS systems at the same time, for example through a **/CHECKPOINT** command that is sent to all IMS systems, it is possible that automatic export processing at one or more IMS systems might fail.

Exporting resource and descriptor definitions with the EXPORT command

Perform the following procedure to export resource and descriptor definitions to the repository:

1. Issue the **EXPORT DEFN TARGET(REPO)** command. Use the parameters for the **EXPORT** command to specify the particular runtime resource and descriptor definitions to export to the repository.

If you are exporting resource and descriptor definitions in the repository for a single IMS system or for multiple IMS systems that each need a unique set of definitions, issue the **EXPORT DEFN TARGET(REPO) NAME(*) TYPE(ALL)** command. In a non-cloned environment, the **EXPORT DEFN TARGET(REPO)** command must be issued to each IMS for which the resource definitions and descriptors are to be exported to the repository. Because the **EXPORT DEFN TARGET(REPO)** command is processed only by the command master IMS, a separate **EXPORT DEFN TARGET(REPO)** command must be issued to each IMS system. You can use the ROUTE keyword on the OM API to specify the IMS to which the command is routed. You do not have to specify the SET(IMSID()) keyword, because IMS defaults the IMS ID to the command master IMS.

If you are exporting resource and descriptor definitions to the repository for multiple IMS systems with the same set of definitions, issue the **EXPORT DEFN TARGET(REPO) NAME(*) TYPE(ALL)** command with the option SET(IMSID(*imslist*)). In the command, *imslist* is the list of IMS IDs of one or more IMS systems in the IMSplex for which the resource and descriptor definitions are to be created in the repository. An IMS resource list containing the definitions is created in the repository for each IMS listed in *imslist*.

Resource and descriptor definitions are written to the repository during **EXPORT** command processing.

2. To verify whether there are any resources that have not been exported to the repository, issue the **QUERY rsc_type SHOW(EXPORTNEEDED)** command, where *rsc_type* can be one of the following resources and resource descriptors: DB, DBDESC, PGM, PGMDESC, RTC, RTCDESC, TRAN, or TRANDESC. Then, if necessary, issue the **EXPORT DEFN TARGET(REPO)** command again.

Related concepts

[“Overview of the IMSRSC repository” on page 37](#)

A repository is a generalized data storage facility that can be used to store any type of information. The IMS resource definition (IMSRSC) repository is a set of VSAM key sequenced data sets (KSDSs) used for storing information. The IMSRSC repository is a repository to store resource (and descriptor) definitions for IMS databases, transactions, programs, and routing codes. This repository is an alternative to the resource definition data set (RDDs) that is used with the dynamic resource definition (DRD) function.

[Shutting down an IMS system that uses dynamic resource definition \(Operations and Automation\)](#)

[“Maintaining your dynamic resource definition environment” on page 91](#)

After you have set up your IMS systems to support dynamic resource definition (DRD), it is important to establish processes to maintain your DRD environment.

Related tasks

[“Updating MODBLKS resource and descriptor definitions in the IMSRSC repository for multiple IMS systems with the same set of definitions” on page 68](#)

You can update MODBLKS resource and descriptor definitions in the IMSRSC repository for multiple IMS systems with the same set of definitions.

[“Creating resource and descriptor definitions in the IMSRSC repository” on page 58](#)

You can create resource and descriptor definitions in the IMSRSC repository for one or more new or existing IMS systems in your IMSplex.

[“Updating MODBLKS resource and descriptor definitions in the IMSRSC repository for a single IMS or for multiple IMSs with unique definitions” on page 67](#)

You can update MODBLKS resource and descriptor definitions in the IMSRSC repository for a single IMS system or for multiple IMS systems that each need a unique set of definitions.

[“Defining the IMSRSC repository” on page 40](#)

Before you can use the IMSRSC repository to store and retrieve resource and descriptor definitions, you must define it. In addition, IMS and the Resource Manager (RM) must have the repository enabled, the Repository Server (RS) must be started and active, and the repository must be started.

[“Enabling dynamic definition for MODBLKS resources with an IMSRSC repository” on page 51](#)

After performing the initial verification of your IMS environment, you can enable dynamic resource definition (DRD) for MODBLKS resources with an IMSRSC repository.

Related reference

[QUERY commands \(Commands\)](#)

[RDDS to Repository utility \(CSLURP10\) \(System Utilities\)](#)

Exporting MSC resource definitions to an IMSRSC repository

You can export MSC resource definitions from IMS to an IMSRSC repository by using the automatic export function and have the resources defined for one or more new or existing IMS systems in your IMSplex.

Before you begin

Before you export MSC resource definitions to the repository, ensure that all of the following prerequisites are met:

- The IMSRSC repository is defined.
- Dynamic resource definition for MSC resources is enabled.
- The IMSRSC repository is enabled for MSC resources.
- MODBLKS=DYN is specified in either or both of the following locations:
 - The COMMON_SERVICE_LAYER section of the DFSDFxxx PROCLIB member
 - The DFSCGxxx member of the IMS PROCLIB data set

About this task

The exported resource definitions overwrite the existing definitions in the repository for the IMS.

Procedure

1. Optional: Check for and identify which resource definitions have not yet been exported to the IMSRSC repository by issuing the `QUERY rsc_type SHOW(EXPORTNEEDED)` command. *rsc_type* can be one of the following resources and resource descriptors: DB, DBDESC, LTERM, MSLINK, MSNAME, MSPLINK, PGM, PGMDESC, RTC, RTCDESC, TRAN, or TRANDESC.

2. Specify AUTOEXPORT=AUTO or AUTOEXPORT=REPO in the DYNAMIC_RESOURCES section of the DFSDFxxx member of the IMS PROCLIB member.

At the next IMS checkpoint, IMS automatically exports the newly created or updated resource definitions since the last automatic export to the IMSRSC repository. The IMS checkpoint can be initiated either by issuing the **/CHECKPOINT** command or automatically by the IMS system.

If you use the **/CHECKPOINT** command to initiate an IMS checkpoint, the command must be routed to each IMS in each IMSplex in which the MSC resources are defined.

3. If errors occurred during automatic export processing, issue the **QUERY rsc_type SHOW(EXPORTNEEDED)** command to display the resource definitions that have not been exported to the IMSRSC repository. Then, you can either wait for the next IMS checkpoint or issue the **/CHECKPOINT** command for the MSC resource definitions to be automatically exported to the IMSRSC repository.

Results

At the end of the automatic export to the IMSRSC repository, the X'22' subtype X'51' log record is written. The log record indicates the IMS IDs that the exported definitions are defined for. A count of the resources that were exported for each resource type is also included in the X'22' subtype X'51' log record.

Related tasks

[Enabling the IMSRSC repository for MSC resources \(Communications and Connections\)](#)

“Enabling dynamic definition for MSC resources” on page 52

Dynamic definition for MSC resources is enabled by specifying MSCRSCS=DYN in the MSC section of the DFSDFxxx member of the IMS PROCLIB data set.

“Defining the IMSRSC repository” on page 40

Before you can use the IMSRSC repository to store and retrieve resource and descriptor definitions, you must define it. In addition, IMS and the Resource Manager (RM) must have the repository enabled, the Repository Server (RS) must be started and active, and the repository must be started.

Related reference

[QUERY LTERM command \(Commands\)](#)

[QUERY MSLINK command \(Commands\)](#)

[QUERY MSNAME command \(Commands\)](#)

[QUERY MSPLINK command \(Commands\)](#)

“MSC section of the DFSDFxxx member” on page 797

The MSC section of the DFSDFxxx member of the IMS PROCLIB data set specifies options for the Multiple Systems Coupling (MSC) function of IMS. The section header must be specified as <SECTION=MSC>. The MSC section is valid in DB/DC and DCCTL environments.

“DYNAMIC_RESOURCES section of the DFSDFxxx member” on page 780

The DYNAMIC_RESOURCES section of the DFSDFxxx member specifies options for import and export, log write ahead, and system resource definition data sets. This section is processed only if DRD is enabled (MODBLKS=DYN). If DRD is not enabled, this section is ignored. The section is defined by the header <SECTION=DYNAMIC_RESOURCES>. The DYNAMIC_RESOURCES section is valid in DB/DC, DBCTL, and DCCTL environments.

Importing resource and descriptor definitions

With dynamic resource definition (DRD) enabled, you can import resource and descriptor definitions from a resource definition data set (RDDS) or the IMSRSC repository by using the automatic import function or the **IMPORT** command.

About this task

You can also use the IMS Manage Resources application that is available from the IMS Application Menu (option 2) to import resource and descriptor definitions into IMS.

Recommendation: Anticipating that you might eventually have to back out the changes that were made by using the **IMPORT DEFN** command, perform these tasks:

- Establish a baseline backout recovery point by issuing an **EXPORT DEFN TARGET(RDDS)** command to export all existing resources and descriptors to a non-system RDDS. If you must back out system definitions afterwards, you can use this set of resources and descriptors with an **IMPORT DEFN** command to restore the resources and descriptors.
- Specify **OPTION(ABORT)** on the **IMPORT DEFN** command so that IMS processes the resource definitions as a group. Either all or none of the definitions are imported.
- If you specify **NAME(*)** on the **IMPORT DEFN** command, command responses are returned only for the resource and descriptor names that resulted in an error. Therefore, also specify **OPTION(ABORT, ALLRSP)** to obtain the command responses for all the resource and descriptor names that are processed.
- Save the output from the **IMPORT DEFN OPTION(ABORT, ALLRSP)** command, which lists all the resources and descriptor names, in case you must back out the changes made by the **IMPORT** command.

Related concepts

[“Overview of the IMSRSC repository” on page 37](#)

A repository is a generalized data storage facility that can be used to store any type of information. The IMS resource definition (IMSRSC) repository is a set of VSAM key sequenced data sets (KSDSs) used for storing information. The IMSRSC repository is a repository to store resource (and descriptor) definitions for IMS databases, transactions, programs, and routing codes. This repository is an alternative to the resource definition data set (RDDS) that is used with the dynamic resource definition (DRD) function.

[“Managing resource and descriptor definitions” on page 31](#)

With dynamic resource definition (DRD) enabled, you can perform several tasks to manage the resource and descriptor definitions for your IMS system.

[“Resource lists for the IMSRSC repository” on page 42](#)

In addition to stored resource definitions and resource descriptors, the IMSRSC repository also contains resource lists.

[“Change lists for the IMSRSC repository” on page 43](#)

IMS warm or emergency restart processes the IMS log to build runtime resource definitions. After the log is processed, if IMS is enabled to use the IMSRSC repository, IMS calls Resource Manager (RM) to read any change list for the IMS.

[Managing IMS resources by using TSO SPOC \(Operations and Automation\)](#)

[Modifying system resources online \(Operations and Automation\)](#)

Related reference

[IMPORT DEFN SOURCE\(REPO | RDDS\) command \(Commands\)](#)

Importing MODBLKS resource and descriptor definitions by using the automatic import function

With dynamic resource definition (DRD) enabled, you can enable the automatic import function so that MODBLKS resource and descriptor definitions are imported to IMS during IMS cold start processing.

Before you begin

For IMS to automatically import definitions from an IMSRSC repository, IMS must be enabled with DRD and the repository.

For IMS to automatically import definitions from a system RDDS, IMS must be enabled with DRD.

For IMS to automatically import definitions from a system RDDS, **AUTOIMPORT=RDDS** or **AUTOIMPORT=AUTO** must be specified in the **DYNAMIC_RESOURCES** section of the **DFSDFXxx** member and all of the conditions listed in the description of the parameter must be true.

For IMS to automatically import definitions from the repository, AUTOIMPORT=AUTO or AUTOIMPORT=REPO must be specified in the DYNAMIC_RESOURCES section of the DFSDFxxx member and all of the conditions listed in the description of the parameter must be true.

About this task

With DRD and the automatic import function enabled, resource definitions are imported from the IMS.MODBLKS data set, or resource and descriptor definitions are imported from a system RDDS or from the repository. When a resource or descriptor definition is imported, IMS creates the control blocks that are used to manage the resource. Information, such as the attributes of the resource or descriptor and the status of the resource, is saved in internal control blocks. The information kept in the control blocks is referred to as the *runtime resource or descriptor definition*. When IMS is up and running, you can use the IMPORT DEFN command to import resource and descriptor definitions from a system or non-system RDDS or from the repository.

Procedure

- To enable automatic import from the repository:
 - a) Make sure the conditions for automatic import from the repository are true.
If all of the following conditions are true, automatic import from the IMSRSC repository is enabled:
 - MODBLKS=DYN is specified to enable DRD in IMS.
 - The REPOSITORY section of the DFSDFxxx member is defined with TYPE=IMSRSC.
 - IMS is enabled with RM services (RMENV=N is not specified in the DFSCGxxx member of the IMS PROCLIB data set or in the CSL section of the DFSDFxxx member of the IMS PROCLIB data set)
 - The CSLRIxxx member of the IMS PROCLIB data set is defined for the repository with TYPE=IMSRSC.
 - The repository contains stored resource definitions for the IMS system.
 - RM is started with the repository enabled.
 - The RS address space is started and available.
 - b) Specify AUTOIMPORT=AUTO or AUTOIMPORT=REPO in the DYNAMIC_RESOURCES section of the DFSDFxxx member of the IMS PROCLIB data set.
- To enable automatic import from an RDDS:
 - a) Make sure the conditions for automatic import from an RDDS are true.
If all of the following conditions are true, automatic import from an RDDS is enabled:
 - MODBLKS=DYN is specified to enable DRD in IMS.
 - The REPOSITORY section of the DFSDFxxx member of the IMS PROCLIB data set is not present.
 - Two or more system RDDSs are defined in the RDDSDSN() parameter of the DFSDFxxx member of the IMS PROCLIB data set.
 - All of the defined RDDSs can be allocated and read.
 - At least one of the RDDSs contains valid resource and descriptor definitions.
 - b) Specify AUTOIMPORT=RDDS or AUTOIMPORT=AUTO in the DYNAMIC_RESOURCES section of the DFSDFxxx member of the IMS PROCLIB data set.
- To enable automatic import from the IMS.MODBLKS data set:
 - a) Make sure the conditions for automatic import from the MODBLKS data set are true.
If all of the following conditions are true, automatic import from the MODBLKS data set is enabled:
 - MODBLKS=DYN is specified to enable DRD in IMS.
 - The REPOSITORY section of the DFSDFxxx member of the IMS PROCLIB data set is not present.
 - No RDDSs are defined in the DFSDFxxx member of the IMS PROCLIB data set, or all the defined RDDSs are empty.

- The MODBLKS data set exists and is not empty.
- b) Perform one of the following tasks:
- Specify AUTOIMPORT=MODBLKS in the DYNAMIC_RESOURCES section of the DFSDFxxx member of the IMS PROCLIB data set.
 - If the repository and RDDS are empty, specify AUTOIMPORT=AUTO in the DYNAMIC_RESOURCES section of the DFSDFxxx member of the IMS PROCLIB data set.

Related concepts

[“Overview of the IMSRSC repository” on page 37](#)

A repository is a generalized data storage facility that can be used to store any type of information. The IMS resource definition (IMSRSC) repository is a set of VSAM key sequenced data sets (KSDSs) used for storing information. The IMSRSC repository is a repository to store resource (and descriptor) definitions for IMS databases, transactions, programs, and routing codes. This repository is an alternative to the resource definition data set (RDDS) that is used with the dynamic resource definition (DRD) function.

[“Maintaining your dynamic resource definition environment” on page 91](#)

After you have set up your IMS systems to support dynamic resource definition (DRD), it is important to establish processes to maintain your DRD environment.

Related tasks

[“Enabling dynamic definition for IMS resource groups” on page 48](#)

Before you can dynamically add, change, or delete a particular type of IMS resource, you must first enable dynamic resource definition for the resource group that includes the resource type.

Related reference

[“DYNAMIC_RESOURCES section of the DFSDFxxx member” on page 780](#)

The DYNAMIC_RESOURCES section of the DFSDFxxx member specifies options for import and export, log write ahead, and system resource definition data sets. This section is processed only if DRD is enabled (MODBLKS=DYN). If DRD is not enabled, this section is ignored. The section is defined by the header <SECTION=DYNAMIC_RESOURCES>. The DYNAMIC_RESOURCES section is valid in DB/DC, DBCTL, and DCCTL environments.

[“REPOSITORY section of the DFSDFxxx member” on page 805](#)

The REPOSITORY section of the DFSDFxxx member specifies the repository types that are to be enabled at IMS. The valid type is: IMSRSC repository, which is used to store the stored resource definitions for DRD resources. The section must begin with the header <SECTION=REPOSITORY>. The REPOSITORY section is valid in DB/DC, DBCTL, and DCCTL environments.

[“COMMON_SERVICE_LAYER section of the DFSDFxxx member” on page 762](#)

The COMMON_SERVICE_LAYER section of the DFSDFxxx member of the IMS PROCLIB data set specifies options for the Common Service Layer (CSL), such as IMSplex name, ACB sharing, global online change, command authorization checking, OLCSTAT, DRD, and global resource status. The section is defined by the header <SECTION=COMMON_SERVICE_LAYER>. The COMMON_SERVICE_LAYER section is valid in DB/DC, DBCTL, and DCCTL environments.

Importing MSC resource definitions by using the automatic import function

With dynamic resource definition (DRD) enabled, you can enable the automatic import function so that MSC resource definitions are imported to IMS during IMS cold start processing.

About this task

With DRD and the automatic import function enabled, resource definitions are imported from the IMSRSC repository or the DFSCLL3x member of the IMS.SDFSRESL data set. When a resource definition is imported, IMS creates the control blocks that are used to manage the resource. Information, such as the attributes and the status of the resource, is saved in internal control blocks. The information kept in the control blocks is referred to as the *runtime resource definition*.

Procedure

- To automatically import MSC resource definitions from the IMSRSC repository, specify `AUTOIMPORT=AUTO` or `AUTOIMPORT=REPO` in the `DYNAMIC_RESOURCES` section of the `DFSDFxxx` member of the IMS PROCLIB data set.

If you are using channel-to-channel (CTC) links, consider removing the DD definitions for the CTC links from the IMS JCL before you import the MSC resources from the IMSRSC repository. This allows the CTC addresses that are defined to be used for the CTC links that are imported from the IMSRSC repository.

If MSC resource definitions exist in the IMSRSC repository, the definitions are imported from the repository at the next IMS cold start.

If an IMS system is cold started on a different z/OS system than the z/OS system where a channel-to-channel link was created and exported, and that channel-to-channel address is not defined on the new z/OS system, the CTC link open fails and omits issuing the `DFS2168I CONNECTION ESTABLISHED ON LINK x` message. However, the automatic import continues. You can use the `UPDATE MSPLINK SET(ADDR(addr))` command to change the address of the MSC physical to an address that is valid for that z/OS system.

- To automatically import MSC resource definitions from the `DFSCLL3x` member of the `IMS.SDFSRESL` data set, specify `AUTOIMPORT=AUTO` in the `DYNAMIC_RESOURCES` section of the `DFSDFxxx` member of the IMS PROCLIB data set.

If the `DFSCLL3x` member exists and is not empty and either or both of the following conditions are true, the MSC resource definitions are automatically imported from the `DFSCLL3x` member at the next IMS cold start:

- The `REPOSITORY` section of the `DFSDFxxx` member of the IMS PROCLIB data set is not present.
- The IMSRSC repository does not contain MSC resource definitions.

Related tasks

[“Exporting MSC resource definitions to an IMSRSC repository” on page 83](#)

You can export MSC resource definitions from IMS to an IMSRSC repository by using the automatic export function and have the resources defined for one or more new or existing IMS systems in your IMSplex.

Related reference

[UPDATE MSPLINK command \(Commands\)](#)

[“DYNAMIC_RESOURCES section of the DFSDFxxx member” on page 780](#)

The `DYNAMIC_RESOURCES` section of the `DFSDFxxx` member specifies options for import and export, log write ahead, and system resource definition data sets. This section is processed only if DRD is enabled (`MODBLKS=DYN`). If DRD is not enabled, this section is ignored. The section is defined by the header `<SECTION=DYNAMIC_RESOURCES>`. The `DYNAMIC_RESOURCES` section is valid in DB/DC, DBCTL, and DCCTL environments.

Importing resource and descriptor definitions from an RDDS by using the IMPORT command

After IMS is up and running, use the **IMPORT DEFN** command to import resource and descriptor definitions from a resource definition data set (RDDS).

About this task

- If the definition is for a resource or descriptor that is unknown to IMS, IMS creates the internal control blocks needed to manage the resource or descriptor.
- If the definition is for a resource or descriptor that exists in IMS and `OPTION(UPDATE)` is not specified, the definition is not imported.
- If the definition is for a resource or descriptor that exists in IMS and `OPTION(UPDATE)` is specified, the definition is imported and the existing runtime resource or descriptor definition is updated with the attributes from the imported definition.

Resource and descriptor definitions can be imported from either the system RDDS with the most current resource and descriptor definitions, or an RDDS that is specified using the `RDDSDSN()` keyword on the `IMPORT DEFN SOURCE(RDDS)` command. The RDDS that is specified with the `RDDSDSN()` command keyword can be a system RDDS or a non-system RDDS. A system RDDS is one of the RDDS data sets that is defined with the `RDDSDSN()` parameter in the `DYNAMIC_RESOURCES` section of the `DFSDFxxx` member of the IMS PROCLIB data set. A system RDDS contains all the resource and descriptor definitions for a single IMS system. If you are using the automatic import or automatic export function, each IMS system must have its own set of system RDDS data sets.

If an RDDS contains multiple definitions for the same resource or descriptor, the last definition imported is the definition that is used to create or update the runtime resource or descriptor definition.

Resources defined by IMS such as the Fast Path utility (`DBF#FPU0`) and the IMS defined descriptors (`DBFDSRT1`, `DFSDSDB1`, `DFSDSPG1`, and `DFSDSTR1`) are restricted and therefore not allowed to be specified on the **IMPORT DEFN** command.

Related concepts

[“Overview of the IMSRSC repository” on page 37](#)

A repository is a generalized data storage facility that can be used to store any type of information. The IMS resource definition (IMSRSC) repository is a set of VSAM key sequenced data sets (KSDSs) used for storing information. The IMSRSC repository is a repository to store resource (and descriptor) definitions for IMS databases, transactions, programs, and routing codes. This repository is an alternative to the resource definition data set (RDDS) that is used with the dynamic resource definition (DRD) function.

Related reference

[IMPORT DEFN SOURCE\(REPO | RDDS\) command \(Commands\)](#)

[Repository to RDDS utility \(CSLURP20\) \(System Utilities\)](#)

Importing resource and descriptor definitions from the IMSRSC repository by using the IMPORT command

You can import resource and descriptor definitions from the IMSRSC repository to IMS by issuing the **IMPORT DEFN SOURCE(REPO)** command.

About this task

Perform the following procedure to import resource and descriptor definitions from the repository:

Procedure

1. Issue the **IMPORT DEFN SOURCE(REPO)** command.

You can use the keyword `SCOPE(ALL)` or `SCOPE(ACTIVE)` to specify whether the command applies to all IMS systems in the IMSplex that have the resource defined (even if some of them are inactive) or only to the active systems.

If `SCOPE(ALL)` is specified and an IMS system to which the resources and descriptors are defined is not active, the command master IMS calls RM to create or update an IMS change list in the repository with a list of the resource and descriptor names being imported. The resource definitions of all the resource names in the IMS change list are imported at warm or emergency restart so that the IMS is synchronized with all other IMS systems in the IMSplex. If a change list is created in the repository, a response line is returned on the **IMPORT** command for each resource name in the change list with the IMSID of the IMS for which the change list is created, along with the import type (`IMPTYPE`) of the change list.

Use the `OPTION(UPDATE)` keyword for the command to indicate that if the definition being imported is for a resource or descriptor that exists in IMS, the imported definition replaces the existing runtime resource or descriptor definition. If the definition being imported is for a resource or descriptor that does not exist, the keyword indicates that the imported definition is used to create the runtime resource or descriptor definition. If the `OPTION(UPDATE)` keyword is not specified and a runtime definition exists for the resource or descriptor, the import of the resource or descriptor definition fails.

The internal control blocks used to manage the resources are either created or updated during **IMPORT DEFN SOURCE(REPO)** command processing.

You can verify the **IMPORT DEFN SOURCE(REPO)** command output.

2. If there was an error from running the **IMPORT DEFN SOURCE(REPO)** command, verify whether the changes have been imported by using one of the **QUERY** commands to ensure that resources are imported.

What to do next

If the changes have not been imported, reissue the **IMPORT DEFN SOURCE(REPO)** command.

Related concepts

[“Overview of the IMSRSC repository” on page 37](#)

A repository is a generalized data storage facility that can be used to store any type of information. The IMS resource definition (IMSRSC) repository is a set of VSAM key sequenced data sets (KSDSs) used for storing information. The IMSRSC repository is a repository to store resource (and descriptor) definitions for IMS databases, transactions, programs, and routing codes. This repository is an alternative to the resource definition data set (RDDS) that is used with the dynamic resource definition (DRD) function.

Related tasks

[“Defining the IMSRSC repository” on page 40](#)

Before you can use the IMSRSC repository to store and retrieve resource and descriptor definitions, you must define it. In addition, IMS and the Resource Manager (RM) must have the repository enabled, the Repository Server (RS) must be started and active, and the repository must be started.

Related reference

[IMPORT DEFN SOURCE\(REPO | RDDS\) command \(Commands\)](#)

[QUERY commands \(Commands\)](#)

Backing out runtime resources imported with the IMPORT command

If you created or updated runtime resources definitions by importing definitions from a resource definition data set (RDDS) or an IMSRSC repository by using the **IMPORT DEFN** command, you can back out those changes to your online system both with and without a cold start of IMS.

Related concepts

[“Overview of the IMSRSC repository” on page 37](#)

A repository is a generalized data storage facility that can be used to store any type of information. The IMS resource definition (IMSRSC) repository is a set of VSAM key sequenced data sets (KSDSs) used for storing information. The IMSRSC repository is a repository to store resource (and descriptor) definitions for IMS databases, transactions, programs, and routing codes. This repository is an alternative to the resource definition data set (RDDS) that is used with the dynamic resource definition (DRD) function.

Related reference

[IMPORT DEFN SOURCE\(REPO | RDDS\) command \(Commands\)](#)

[DELETE commands \(Commands\)](#)

[EXPORT command \(Commands\)](#)

Backing out runtime definitions imported by the IMPORT command with a cold start of IMS

If you created or updated runtime resources definitions by importing definitions from a resource definition data set (RDDS) or the IMSRSC repository by using the **IMPORT DEFN** command, you can back out the changes to your online system with a cold start of IMS.

Before you begin

Prerequisite: This option requires that all the resource and descriptor definitions were exported to a non-system RDDS before the original **IMPORT DEFN** command was issued.

About this task

For resources imported from an RDDS, perform the following steps:

Procedure

1. Cold start IMS with no MODBLKS resources defined (by specifying `AUTOIMPORT=N` in the Dynamic Resources section of the `DFSDFxxx` member of the IMS PROCLIB data set).
2. Issue the **IMPORT DEFN SOURCE(RDDS)** command to import all the definitions from the non-system RDDS that was created for backout recovery before the original **IMPORT DEFN** command was issued.

What to do next

After the backout is complete, if you are running with system RDDSs defined, issue the **EXPORT DEFN TARGET(RDDS)** command to export the current definitions to a system RDDS. Or, if you are running with the IMSRSC repository enabled, issue the **EXPORT DEFN TARGET(REPO)** command or use the automatic export function to export the current definitions to the repository.

Backing out runtime definitions imported by the IMPORT command without a cold start of IMS

If you created or updated runtime resources definitions by importing definitions from a resource definition data set (RDDS) or an IMSRSC repository by using the **IMPORT DEFN** command, you can back out the changes to your online system without a cold start of IMS.

Before you begin

Prerequisite: This option requires that all the resource and descriptor definitions were exported to a non-system RDDS before the original **IMPORT DEFN** command was issued. It also requires that you saved the output generated from the **IMPORT DEFN** command, which shows the resource and descriptor definitions that were created or updated as a result of the **IMPORT DEFN** command.

About this task

To back out the changes:

Procedure

1. Issue **DELETE** commands for any resource and descriptor definitions that were created by the **IMPORT DEFN** command.
2. Issue the **IMPORT DEFN** command with `OPTION(UPDATE)` to import the stored definitions, from the non-system RDDS, for any resource and descriptor definitions that were updated by the **IMPORT DEFN** command.

What to do next

After the backout is complete, if you are running with system RDDSs defined, issue the **EXPORT DEFN TARGET(RDDS)** command to export the current definitions to a system RDDS. Or, if you are running with the IMSRSC repository enabled, issue the **EXPORT DEFN TARGET(REPO)** command or use the automatic export function to export the current definitions to the repository.

Maintaining your dynamic resource definition environment

After you have set up your IMS systems to support dynamic resource definition (DRD), it is important to establish processes to maintain your DRD environment.

Here are some steps to follow to establish processes to maintain your DRD environment.

Enabling automatic export to an IMSRSC repository

Enable the automatic export function to an IMSRSC repository by:

- Defining the IMSRSC repository.
- Specifying `AUTOEXPORT=AUTO` or `AUTOEXPORT=REPO` in the `DYNAMIC_RESOURCES` section of the `DFSDFxxx` member in the `IMS.PROCLIB` data set.
- For MSC resources, specifying `MSCREPO=Y` in the `MSC` section of the `DFSDFxxx` member.

When automatic export to a repository is enabled, your resource and descriptor definitions are automatically exported to the repository at IMS checkpoint if the attribute values of one or more of your resources or descriptors have changed since the last IMS checkpoint. If you later must perform a cold start, and IMS is not enabled with the RDDS, IMS imports the resource and descriptor definitions from the repository and creates runtime resource and descriptor definitions that it must run.

Enabling automatic export to an RDDS for MODBLKS resources

Enable the automatic export function to an RDDS for MODBLKS resources by performing the following tasks. MSC resources do not support RDDSs.

- Defining two or more system resource definition data sets.
- Specifying `AUTOEXPORT=AUTO` in the `DYNAMIC_RESOURCES` section of the `DFSDFxxx` member in the `IMS PROCLIB` data set.

When automatic export is enabled, your resource and descriptor definitions are automatically exported to an RDDS at IMS checkpoint if the attribute values of one or more of your resources or descriptors have changed since the last IMS checkpoint. If you later must perform a cold start, and IMS is not enabled with the IMSRSC repository, or the repository is empty, IMS imports the resource and descriptor definitions from the RDDS and creates the runtime resource and descriptor definitions that it must run.

Exporting MODBLKS resource definitions to a repository or RDDS by using the EXPORT command

If the attribute values of one or more of your MODBLKS resources or descriptors have changed since the last IMS checkpoint, save the definitions to a repository or an RDDS.

As an alternative to enabling the automatic export function to a repository, use the **EXPORT DEFN TARGET(REPO)** command to save your current resource and descriptor definition to a repository.

As an alternative to enabling the automatic export function to an RDDS, use the **EXPORT DEFN TARGET(RDDS)** command to save your current resource and descriptor definition to an RDDS.

Enabling automatic import

Enable the automatic import function by specifying `AUTOIMPORT=AUTO` in the `DYNAMIC_RESOURCES` section of the `DFSDFxxx` member of the `IMS PROCLIB` data set. When `AUTOIMPORT=AUTO` is specified, IMS determines whether to enable automatic import processing. If IMS enables automatic import, it also determines the data source from which to import the definitions.

Whether the conditions for automatic import that are listed in the description of the `AUTOIMPORT` parameter are met determines if automatic import from one of the following data sources takes place:

- A MODBLKS data set
- A `DFSCLL3x` member of the `IMS.SDFSRESL` data set
- An RDDS
- A repository

If you delete runtime resource definitions from a data source by using a **DELETE** command and then cold start IMS, the deleted resource definitions reappear if the automatic import function is enabled and the definitions still exist in another data source from which automatic import can take place.

Backing up repository definitions

You can use VSAM backup utilities to create backups of repository data sets.

Alternately, for MODBLKS resources, you can maintain an RDDS that contains equivalent repository definitions for each IMS that uses the repository. Use the Repository to RDDS utility (CSLURP20) to generate an RDDS from the repository for each IMS that uses the repository.

For MODBLKS resources, you can also use the newly generated RDDS as input to the RDDS to Repository utility (CSLURP10) to copy resource and descriptor definitions from one repository to another repository.

Reorganizing repository data sets

Periodically reorganize the repository data sets by using VSAM reorganization utilities.

Adjusting repository data sets with the FRPBATCH commands

As needed, use the FRPBATCH commands to make adjustments to your repository data sets. For example:

- Use the ADD command to add a repository to the Repository Server (RS) catalog repository data sets.
- Use the DELETE command to remove a repository from the RS catalog repository data sets.
- Use the DSCHANGE command to change the status of a repository data set pair to either DISCARD or SPARE.
- Use the RENAME command to rename a repository.
- Use the UPDATE command to update a repository definition in the RS catalog repository data sets. Use this command to change the repository data sets or the AUTOOPEN specification of a repository.

Removing IMS.MODBLKS data sets

When DRD is enabled, the IMS.MODBLKS data sets are no longer required. After you are satisfied with the setup of your DRD environment and it is running successfully, you can remove the IMS.MODBLKS data sets. If automatic import is enabled, resource and descriptor definitions are imported during IMS cold start from the RDDS or the repository that contains the most current data. However, you can continue to use the IMS.MODBLKS data set as the source for all of your resource definitions, instead of an RDDS or repository. If you choose to continue using the IMS.MODBLKS data set, keep your system definition macros synchronized with the changes you make dynamically using DRD commands.

Removing the DFSCLL3x and DFSCLR0x members and updating the DFSCLC0x member of the IMS.SDFSRESL data set

If you use the IMSRSC repository to store dynamically defined MSC resources, the DFSCLL3x and DFSCLR0x members of the IMS.SDFSRESL data set are no longer required. Because the DFSCLC0x member might contain non-MSC resources, the DFSCLC0x might still be required. After you are satisfied with the setup of your DRD environment for MSC resources, the DRD environment is running successfully, and your MSC resources are exported to the IMSRSC repository, you can remove the DFSCLL3x and DFSCLR0x members. For the DFSCLC0x member, update the member to remove MSC logical link path definitions. If automatic import is enabled, MSC resource definitions are imported during IMS cold start from the repository that contains the most current data. However, you can continue to use the DFSCLL3x, DFSCLR0x, and DFSCLC0x members as the source for your MSC resource definitions, instead of a repository. If you continue to use the DFSCLL3x, DFSCLR0x, and DFSCLC0x members, keep your system definition macros synchronized with the changes you make dynamically using DRD commands.

Synchronizing the contents of IMS.MODBLKS

As you migrate to using RDDSs or the repository, keep resource definitions that are in the IMS.MODBLKS data set synchronized with the resource definitions that are in the RDDS or repository. This synchronization enables you to maintain a viable IMS.MODBLKS data set if you must disable DRD

and fall back to using the online change process for the resources in the IMS.MODBLKS data set. To keep your IMS.MODBLKS data set synchronized with your online definitions, update your static macro definitions with the changes that you make dynamically using type-2 commands. When changes are made dynamically, perform a MODBLKS system definition to add, change, or delete resources from the IMS.MODBLKS data set.

Synchronizing the DFSCLL3x, DFSCLR0x, and DFSCLC0x members of the IMS.SDFSRESL data set

If you migrate to using the IMSRSC repository for dynamically defined MSC resources but continue to use the DFSCLL3x, DFSCLR0x, and DFSCLC0x members of the IMS.SDFSRESL data set, keep resource definitions that are in the members synchronized with the resource definitions that are in the repository. This synchronization enables you to maintain viable DFSCLL3x, DFSCLR0x, and DFSCLC0x members if you must disable DRD and fall back to using the system generation process for MSC resources. To keep your DFSCLL3x, DFSCLR0x, and DFSCLC0x members synchronized with your online definitions, update your static macro definitions with the changes that you make dynamically using type-2 commands. When changes are made dynamically, perform a MSC system definition to add, change, or delete resources from the DFSCLL3x, DFSCLR0x, and DFSCLC0x members.

Related concepts

[“Overview of the IMSRSC repository” on page 37](#)

A repository is a generalized data storage facility that can be used to store any type of information. The IMS resource definition (IMSRSC) repository is a set of VSAM key sequenced data sets (KSDSs) used for storing information. The IMSRSC repository is a repository to store resource (and descriptor) definitions for IMS databases, transactions, programs, and routing codes. This repository is an alternative to the resource definition data set (RDDS) that is used with the dynamic resource definition (DRD) function.

[“Exporting MODBLKS resource and descriptor definitions to an IMSRSC repository” on page 81](#)

You can export resource and descriptor definitions from IMS to an IMSRSC repository by using the automatic export function or by issuing the EXPORT DEFN TARGET(REPO) command. You can export resource and descriptor definitions from the IMS system to the repository and have them defined for one or more new or existing IMS systems in your IMSplex.

Related tasks

[“Importing MODBLKS resource and descriptor definitions by using the automatic import function” on page 85](#)

With dynamic resource definition (DRD) enabled, you can enable the automatic import function so that MODBLKS resource and descriptor definitions are imported to IMS during IMS cold start processing.

[“Falling back from using the IMSRSC repository” on page 95](#)

After using the IMSRSC repository to store resource and descriptor definitions, you can fall back either to using a resource definition data set (RDDS) or the MODBLKS data set instead for MODBLKS resources. For MSC resources, you can fall back to using the IMS.DFSCLL3x, IMS.DFSCLC0x, and IMS.DFSCLR0x data sets.

Related reference

[“DYNAMIC_RESOURCES section of the DFSDFxxx member” on page 780](#)

The DYNAMIC_RESOURCES section of the DFSDFxxx member specifies options for import and export, log write ahead, and system resource definition data sets. This section is processed only if DRD is enabled (MODBLKS=DYN). If DRD is not enabled, this section is ignored. The section is defined by the header <SECTION=DYNAMIC_RESOURCES>. The DYNAMIC_RESOURCES section is valid in DB/DC, DBCTL, and DCCTL environments.

[“MSC section of the DFSDFxxx member” on page 797](#)

The MSC section of the DFSDFxxx member of the IMS PROCLIB data set specifies options for the Multiple Systems Coupling (MSC) function of IMS. The section header must be specified as <SECTION=MSC>. The MSC section is valid in DB/DC and DCCTL environments.

[/CHECKPOINT command \(Commands\)](#)

[EXPORT command \(Commands\)](#)

[Repository to RDDS utility \(CSLURP20\) \(System Utilities\)](#)

[RDDS to Repository utility \(CSLURP10\) \(System Utilities\)](#)

Related information

[Commands for FRPBATCH \(System Programming APIs\)](#)

Converting resource definitions into IMS stage 1 macro statements or IMS type-2 CREATE commands

After you create resource definitions and export them to a resource definition data set (RDDS), you can use the RDDS Extraction utility (DFSURDD0) to convert the resource definitions that are in the RDDS into either IMS stage 1 macro statements, or IMS type-2 CREATE commands.

If you want to convert the resource definitions in an IMSRSC repository into IMS stage 1 macro statements or IMS type-2 CREATE commands, first use the Repository to RDDS utility (CSLURP20) to generate an RDDS from a repository.

You can convert the resource definitions into IMS stage 1 APPLCTN, DATABASE, RTCODE, and TRANSACT macro statements.

The type-2 CREATE commands into which you can convert the resource definitions include:

- **CREATE DB**
- **CREATE DBDESC**
- **CREATE PGM**
- **CREATE PGMDESC**
- **CREATE RTC**
- **CREATE RTCDESC**
- **CREATE TRAN**
- **CREATE TRANDESC**

For additional information about the Resource Definition Data Set (RDDS) Extraction utility, see *IMS Version 15.4 System Utilities*.

Related reference

[Repository to RDDS utility \(CSLURP20\) \(System Utilities\)](#)

Falling back from using the IMSRSC repository

After using the IMSRSC repository to store resource and descriptor definitions, you can fall back either to using a resource definition data set (RDDS) or the MODBLKS data set instead for MODBLKS resources. For MSC resources, you can fall back to using the IMS.DFSCLL3x, IMS.DFSCLC0x, and IMS.DFSCLR0x data sets.

Falling back from using the IMSRSC repository for MODBLKS resources

After using the IMSRSC repository to store MODBLKS resource and descriptor definitions, you can fall back to using a resource definition data set (RDDS) or the MODBLKS data set instead.

About this task

To fall back to using a resource definition data set (RDDS) or the MODBLKS data set (repeat these steps for each IMS system you are falling back):

Procedure

1. Copy the stored resource definitions for the IMS from the repository to a non-system RDDS using the Repository to RDDS utility (CSLURP20).

If multiple IMS systems are falling back, copy each set of IMS resource definitions to their own RDDS data set.

2. If falling back to the MODBLKS data set, generate MODBLKS or Stage-1 output using the DFSURDDO utility.

The input to the DFSURDDO is the output RDDS generated from the CSLURP20 utility.

3. Shut down the IMS system that is falling back.
4. Issue the **DELETE DEFN** command for all of the MODBLKS resource types that have resource definitions in the IMSRSC repository for the IMS that is falling back.

Issue the **DELETE DEFN** command with keywords FOR(IMSID(IMS1)) and NAME(*) for each resource type. For example, if IMS1 is falling back, to delete database resources, issue:

```
DELETE DEFN TARGET(REPO) NAME(*) TYPE(DB)FOR(IMSID(IMS1))
```

5. If the IMSRSC repository is no longer required for any other resource and descriptor definition, remove the REPOSITORY section from the DFSDFxxx member of the IMS PROCLIB data set.
6. If the IMSRSC repository is no longer required for any other resource and descriptor definition, change the specification for automatic import from the repository to RDDS or MODBLKS.

Complete one of the following steps:

- If you want to import the definitions from an RDDS, change the DYNAMIC_RESOURCES section of the DFSDFxxx member to indicate AUTOIMPORT=RDDS or AUTOIMPORT=AUTO to ensure that the RDDS is read during cold start. Then, set one of the system RDDS data set names in the DYNAMIC_RESOURCES section of the DFSDFxxx member to the name of the RDDS generated in Step “1” on page 95. The other system RDDSs defined in the DFSDFxxx member must be empty or have an earlier time stamp than the RDDS generated in Step “1” on page 95.
- If you want to import the resources from a MODBLKS data set, change the DYNAMIC_RESOURCES section of the DFSDFxxx member to indicate AUTOIMPORT=MODBLKS or AUTOIMPORT=AUTO to ensure that the MODBLKS data set is read during cold start. If AUTOIMPORT=AUTO is specified, the repository and RDDSs, if they exist, must be empty. During IMS cold start, IMS reads the MODBLKS data set to create the runtime resource definitions.

7. Perform a cold start of IMS.

Results

During IMS cold start, IMS reads the RDDS data set or MODBLKS data set to create the runtime resource definitions.

What to do next

When all IMS systems have fallen back to not using the repository, you can disable RM from using the repository and stop the RS address spaces.

Related concepts

[“Overview of the IMSRSC repository” on page 37](#)

A repository is a generalized data storage facility that can be used to store any type of information. The IMS resource definition (IMSRSC) repository is a set of VSAM key sequenced data sets (KSDSs) used for storing information. The IMSRSC repository is a repository to store resource (and descriptor) definitions for IMS databases, transactions, programs, and routing codes. This repository is an alternative to the resource definition data set (RDDS) that is used with the dynamic resource definition (DRD) function.

[“IMS repository index and member data sets” on page 164](#)

Each IMS repository definition has room for three pairs of repository data sets, identified as RDS1, RDS2, and RDS3. Each pair consists of a repository index data set (RID) and a repository member data set (RMD).

[“Maintaining your dynamic resource definition environment” on page 91](#)

After you have set up your IMS systems to support dynamic resource definition (DRD), it is important to establish processes to maintain your DRD environment.

Related tasks

[“Disabling dynamic resource definition ” on page 99](#)

You might need to disable the dynamic resource definition (DRD) process for MODBLKS resources and fall back to using the online change process. You also might need to disable the DRD process for MSC resources and fall back to using the system generation process.

[Stopping the Repository Server \(Operations and Automation\)](#)

[Removing an IMSRSC repository from the RS catalog repository \(System Administration\)](#)

[“Defining the IMSRSC repository” on page 40](#)

Before you can use the IMSRSC repository to store and retrieve resource and descriptor definitions, you must define it. In addition, IMS and the Resource Manager (RM) must have the repository enabled, the Repository Server (RS) must be started and active, and the repository must be started.

[“Disabling RM from using the repository and stopping the RS address spaces” on page 99](#)

When all IMS systems have fallen back to not using the repository, you can disable RM from using the repository and stop the RS address spaces.

Related reference

[“CSLRxxxx member of the IMS PROCLIB data set” on page 719](#)

Use the CSLRxxxx member of the IMS PROCLIB data set to specify parameters that initialize RM.

[Repository to RDDS utility \(CSLURP20\) \(System Utilities\)](#)

[DELETE DEFN command \(Commands\)](#)

[z/OS: DFSMS Access Method Services for Catalogs](#)

[“DYNAMIC_RESOURCES section of the DFSDFxxx member” on page 780](#)

The DYNAMIC_RESOURCES section of the DFSDFxxx member specifies options for import and export, log write ahead, and system resource definition data sets. This section is processed only if DRD is enabled (MODBLKS=DYN). If DRD is not enabled, this section is ignored. The section is defined by the header <SECTION=DYNAMIC_RESOURCES>. The DYNAMIC_RESOURCES section is valid in DB/DC, DBCTL, and DCCTL environments.

Falling back from using the IMSRSC repository for MSC resources without a stage-1 system definition

After using the IMSRSC repository to store resource and descriptor definitions, you can fall back from using the repository for MSC resources without performing a stage-1 system definition.

Procedure

Repeat the following steps for each IMS system you are falling back:

1. Manually keep a list of the **CREATE MSPLINK**, **CREATE MSLINK**, **CREATE MSNAME**, and **CREATE LTERM** commands that are equivalent to the MSC resources that are defined to IMS. Include both the MSC resources that were created during the system generation process and those that were generated dynamically.
2. Issue the **DELETE DEFN** command for all of the MSC resource types that have resource definitions in the IMSRSC repository for the IMS that is falling back. Issue the **DELETE DEFN** command with keywords FOR(IMSID(IMS1)) and NAME(*) for each resource type.

For example, if IMS1 is falling back, to delete database resources, issue:

```
DELETE DEFN TARGET(REPO) NAME(*) TYPE(DB)FOR(IMSID(IMS1))
```

3. If the IMSRSC repository is no longer required for any other resource and descriptor definition, remove the REPOSITORY section from the DFSDFxxx member of the IMS PROCLIB data set.
4. In the MSC section of the DFSDFxxx member of the IMS PROCLIB data set, change MSCREPO=Y to MSCREPO=N or remove the MSCREPO= parameter.

5. Cold start IMS.
6. Issue **CREATE** commands for the MSC resources from a batch SPOC, Rexx SPOC, or manually.

What to do next

When all IMS systems have fallen back to not using the repository for all resource and descriptor definitions, you can disable RM from using the repository and stop the RS address spaces.

Related tasks

[“Disabling RM from using the repository and stopping the RS address spaces” on page 99](#)

When all IMS systems have fallen back to not using the repository, you can disable RM from using the repository and stop the RS address spaces.

Falling back from using the IMSRSC repository for MSC resources with a stage-1 system definition

After using the IMSRSC repository to store resource and descriptor definitions, you can fall back to using the IMS.DFSCLL3x, IMS.DFSCLC0x, and IMS.DFSCLR0x data sets for MSC resources by performing a stage-1 system definition.

Procedure

Repeat the following steps for each IMS system that you are falling back:

1. Keep your stage-1 system definition synchronized with dynamic definition of MSC resources.
2. If you are using channel-to-channel (CTC) links, uncomment or add back the CTC link DD in the IMS JCL.
3. Issue the **DELETE DEFN** command for all of the MSC resource types that have resource definitions in the IMSRSC repository for the IMS that is falling back. Issue the **DELETE DEFN** command with keywords FOR(IMSID(IMS1)) and NAME(*) for each resource type.

For example, if IMS1 is falling back, to delete database resources, issue:

```
DELETE DEFN TARGET(REPO) NAME(*) TYPE(DB)FOR(IMSID(IMS1))
```

4. If the IMSRSC repository is no longer required for any other resource and descriptor definition, remove the REPOSITORY section from the DFSDFxxx member of the IMS PROCLIB data set.
5. Run system generation for stage-1 system definition that includes MSC resources, which are the following:
 - MSPLINK, MSLINK, MSNAME, and NAME macros
 - IMSCTRL macro with MSVID and SYSTEM=(MSVERIFY) parameters specified
 - APPLCTN and TRANSACT macros with the SYSID parameter specified
6. Cold start IMS.

What to do next

When all IMS systems have fallen back to not using the repository for all resource and descriptor definitions, including both MODBLKS and MSC resources, you can disable RM from using the repository and stop the RS address spaces.

Related tasks

[“Disabling RM from using the repository and stopping the RS address spaces” on page 99](#)

When all IMS systems have fallen back to not using the repository, you can disable RM from using the repository and stop the RS address spaces.

Disabling RM from using the repository and stopping the RS address spaces

When all IMS systems have fallen back to not using the repository, you can disable RM from using the repository and stop the RS address spaces.

Procedure

1. Remove the REPOSITORY section from the CSLRIxxx member of the IMS PROCLIB data set at each RM.
2. Issue the **UPDATE RM TYPE(REPO) REPOTYPE(IMSRSC) SET(REPO(N))** command to disable all RMs from using the repository.
3. Issue the **QUERY RM TYPE(REPO) SHOW(ALL)** command to ensure that all RMs are not using the repository.
4. Shut down all of the Repository Server (RS) address spaces by issuing the **F reposername, SHUTDOWN ALL** command.
5. Delete the IMSRSC repository and RS catalog repository data sets.
To delete the data sets, use the z/OS Access Method Services (IDCAMS) utility or a similar method.
6. Delete the z/OS log stream if the RS audit log is not needed.
You can use the IXCM2APU program to delete the log stream.

Disabling dynamic resource definition

You might need to disable the dynamic resource definition (DRD) process for MODBLKS resources and fall back to using the online change process. You also might need to disable the DRD process for MSC resources and fall back to using the system generation process.

Disabling dynamic resource definition for MODBLKS resources

You might need to disable the dynamic resource definition (DRD) process for MODBLKS resources and fall back to using the online change process.

Before you begin

With DRD enabled, ensure that the IMS.MODBLKS data set has a complete set of the current resource definitions. This complete set includes resource definitions that were originally in the IMS.MODBLKS data set or in the RDDS at cold start, and that were not changed or deleted dynamically. It also includes any resource definitions that were added or changed dynamically since cold start. This check enables you to fall back to using online change for the IMS.MODBLKS data set with all the resources that were either defined originally by system definition or defined dynamically.

Perform the following procedure to disable the DRD process and fall back to using the online change process:

Procedure

1. Use one of the following methods to synchronize your IMS.MODBLKS data set with your online definitions:
 - Update your static macro definitions with the changes that you make dynamically using type-2 commands. When changes are made dynamically, perform a MODBLKS system definition to update the IMS.MODBLKS data set.
 - Generate an RDDS for the IMS with the resource definitions at the IMS. Use the **EXPORT** command to export the definitions from IMS to an RDDS. When IMS is using the IMSRSC repository, the

non-system RDDS can be generated using the EXPORT DEFN command or by using the Repository to RDDS utility (CSLURP20).

Use the Resource Definition Data Set (RDDS) Extraction utility (DFSURDD0) to extract the resource definitions to create Stage-1 macro statements from the stored resource definitions in an RDDS. Then perform a MODBLKS system definition to update the IMS.MODBLKS data set.

2. Shut down IMS normally.
3. Enable online change for the IMS.MODBLKS data set:
 - a) Perform one of the following steps:
 - Remove the MODBLKS keyword from the DFSCGxxx member of the IMS PROCLIB data set. Optionally, also remove the MODBLKS keyword from the COMMON_SERVICE_LAYER section of the DFSDFxxx member of the IMS PROCLIB data set.

If both members are defined, any values specified in DFSCGxxx override those values that are in DFSDFxxx.
 - Change the value of the MODBLKS keyword from DYN to OLC in the DFSCGxxx member of the IMS PROCLIB data set. Optionally, also change the value of the MODBLKS keyword from DYN to OLC in the COMMON_SERVICE_LAYER section of the DFSDFxxx member of the IMS PROCLIB data set.

If both members are defined, any values specified in DFSCGxxx override those values that are in DFSDFxxx.
 - b) Specify AUTOIMPORT=MODBLKS or AUTOIMPORT=AUTO in the DFSDFxxx member of the IMS PROCLIB data set.
 - c) Remove all RDDS statements from the DFSDFxxx member of the IMS PROCLIB data set. If the repository is not required for any other IMS functions, also remove all repository statements from the DFSDFxxx member.

Important: If the repository statement is required for other IMS resources and AUTOIMPORT=AUTO is specified in the DFSDFxxx member, ensure that all of the MODBLKS resources are deleted from the repository.
4. Ensure that the IMS JCL includes the MODBLKS DD statement.
5. Cold start IMS. An IMS cold start creates runtime resource definitions from the stored resource definitions in the IMS.MODBLKS data set.

The online change process for the IMS.MODBLKS data set is enabled again (and DRD is disabled). No variations of the **CREATE** and **DELETE** commands are allowed in a non-DRD environment. Some variations of the **UPDATE** command are allowed. You can issue an **EXPORT DEFN TARGET(RDDS)** command to export to a non-system RDDS.
6. Reestablish your in-house procedures that use the online change process for the IMS.MODBLKS data set, and disable the in-house procedures that use DRD commands.

If you have been using the repository and all IMS systems are falling back to the online change process, disable RM from using the repository and stop the RS address spaces.

Related concepts

[“Overview of the IMSRSC repository” on page 37](#)

A repository is a generalized data storage facility that can be used to store any type of information. The IMS resource definition (IMSRSC) repository is a set of VSAM key sequenced data sets (KSDSs) used for storing information. The IMSRSC repository is a repository to store resource (and descriptor) definitions for IMS databases, transactions, programs, and routing codes. This repository is an alternative to the resource definition data set (RDDS) that is used with the dynamic resource definition (DRD) function.

Related tasks

[“Falling back from using the IMSRSC repository” on page 95](#)

After using the IMSRSC repository to store resource and descriptor definitions, you can fall back either to using a resource definition data set (RDDS) or the MODBLKS data set instead for MODBLKS resources.

For MSC resources, you can fall back to using the IMS.DFSCLL3x, IMS.DFSCLC0x, and IMS.DFSCLR0x data sets.

[“Disabling RM from using the repository and stopping the RS address spaces” on page 99](#)

When all IMS systems have fallen back to not using the repository, you can disable RM from using the repository and stop the RS address spaces.

Disabling dynamic resource definition for MSC resources

You might need to disable the dynamic resource definition (DRD) process for MSC resources and fall back to using the system generation process.

Before you begin

With DRD enabled for MSC resources, ensure that the IMS.DFSCLL3x, IMS.DFSCLC0x, and DFSCLR0x data sets have a complete set of the current resource definitions. This complete set includes resource definitions that were originally in the the IMS.DFSCLL3x, IMS.DFSCLC0x, and IMS.DFSCLR0x data sets at cold start, and that were not changed or deleted dynamically. It also includes any resource definitions that were added or changed dynamically since cold start. This check enables you to fall back to using the system generation process with all the resources that were either defined originally by system definition or defined dynamically.

To disable the DRD process and fall back to using the system generation process:

Procedure

1. Update your static macro definitions with the changes that you make dynamically using type-2 commands. When changes are made dynamically, complete a system definition to update the IMS.DFSCLL3x, IMS.DFSCLC0x, and IMS.DFSCLR0x data sets.
2. Shut down IMS normally.
3. Enable system generation for the IMS.DFSCLL3x, IMS.DFSCLC0x, and IMS.DFSCLR0x data sets by removing the MSCRSCS=DYN definition from the MSC section of the DFSDFxxx member of the IMS PROCLIB data set and specifying AUTOIMPORT=AUTO.
4. Cold start IMS. An IMS cold start creates runtime resource definitions from the stored resource definitions in the IMS.DFSCLL3x, IMS.DFSCLC0x, and IMS.DFSCLR0x data sets. No variations of the CREATE and DELETE commands are allowed in a non-DRD environment. Some variations of the UPDATE command are allowed.
5. Reestablish your in-house procedures that use the system generation process and disable the in-house procedures that use DRD commands.

Related reference

[MSC section of the DFSDFxxx member \(System Definition\)](#)

Chapter 3. Designing the IMS system

Before you can use the Information Management System Transaction Manager (IMS TM) and the Information Management System Database Manager (IMS DB), you must define the elements and functions that make up an IMS system. These elements and functions include databases, application programs, terminals, buffer pool sizes, security options, and more.

The parameters that are associated with the IMS system configuration macros create the integrity of the IMS online system. These parameters specify resources that are available for system checkpoints and program isolation. The allocation of system data sets and control program storage depends upon the expected processing load and the strategy for recovery of the online IMS system.

Choosing the number of regions

One system definition task is to specify how many BMP and message regions comprise your IMS system. The number of regions can vary depending on what your operations require.

Use the MAXREGN keyword on the IMSCTRL macro to specify a working set of BMP and message regions.

Your operations procedure stipulates how many regions are active and when they are active. The scheduling algorithm controls the actual programs that execute in the regions in response to enqueued messages. Overall throughput is conditionally based on the number of active dependent regions and the availability of shared resources for database processing. A processing program must have an available message region before it can enter the scheduling selection logic.

Up to 999 other dependent regions can be dynamically allocated by the MTO using the /START command. For DBCTL, the maximum sum of BMPs and DRA threads is 999.

Setting a checkpoint frequency

IMS records information for restarting interrupted operations by using checkpoints. When an operation is interrupted, reprocessing occurs from the point of system interruption to a forward continuation point. Using the status information captured during checkpoint, IMS can restore the content of the message queues and database changes.

Use one of the following methods to control the frequency of IMS internal checkpoints:

- Specify the **CPLOG=** parameter in the DFSPBxxx member of the IMS PROCLIB data set.
- Specify the **CPLOG=** parameter in JCL.

The value you choose for this parameter represents the number of system log records that are created before a new system checkpoint is invoked. When the increment exceeds the **CPLOG=** value, checkpoint processing begins. The default is 500,000. You can also use the **/CHECKPOINT** command to initiate a checkpoint. Application programs that are authorized to enter the **/CHECKPOINT** command can also initiate a checkpoint. The **/CHECKPOINT** command, used with certain parameters, shuts down your IMS system. Make sure that you understand the consequences of shutting down the system before you issue this command. After the checkpoint, use the **/NRESTART** command to restart the system.

Take frequent checkpoints to minimize the amount of time it takes to do a restart. The trade-off for taking frequent checkpoints (and efficient restart) is an increase in processing overhead.

You can change the CPLOG value by using the /CHANGE CPLOG command. To calculate a revised CPLOG value, use the transaction profiles and estimate, for a small peak processing interval, the number of system log events. The number of log records exceeds the sum of the following values:

- (Number of input transactions) x 2
- (Number of output messages) x 3
- (Number of secondary transactions) x 2
- (Number of database update calls for REPL,DLET)

- (Number of database inserts) x 2
- (Number of related index pointer maintenance calls) x 2
- (Number of programs scheduled and terminated)
- (Number of checkpoint calls from programs) x 3

To ensure an accurate estimate, your checkpoint frequency should be large enough to extend beyond the estimated response time for at least one of the longest-running transactions.

You can adjust the checkpoint frequency using /CHANGE CPLOG after observing the stability of the online IMS system. Use IMS Monitor reports to assess the processing overhead. The Region Summary report shows the total elapsed time and average elapsed time taken for checkpoints in the trace interval.

Related reference

[/CHECKPOINT command \(Commands\)](#)

Selecting an IMS lock manager

To protect database integrity, an IMS system serializes requests for database resources to ensure that no two application programs are allowed to update a database segment concurrently. Lock management is the process of controlling concurrent requests.

For lock management, you can use either or both of the following methods:

- A program isolation lock manager
- The services of the Internal Resource Lock Manager (IRLM) component

The program isolation lock manager controls only lock requests for a single IMS system (local locking); the IRLM controls requests for multiple IMS systems (global locking), as well as for a single system.

You can monitor program isolation activity using the IMS Monitor, which is invoked by the /TRACE command. A separate program isolation trace can also be used to analyze performance. The advantage of using program isolation to manage locks is that you do not need any special operating and recovery procedures, as is necessary for the IRLM.

The IRLM component is used as a part of data sharing. With program isolation, all activity (modifying the database and creating messages) of an application program that is active in the DB/DC environment is isolated from any other application programs that are active in the system. The isolation persists until that application program confirms, by reaching a synchronization point, that the data it has modified or created is valid.

Note: The PI lock manager supports a maximum of 63 waiting application programs in an IMS system. If an application program that must wait for a lock exceeds the maximum that the PI lock manager supports, the application program terminates with an abend 2478, is backed out by IMS, and its locks are released. If the requestor is a message-driven program (MPP, JMP, IFP, or BMP) the message is returned to the queue and is reprocessed.

To indicate that an IRLM is to manage locking, specify the IRLM's z/OS subsystem name on the IRLMNM parameter of the IMSCTRL macro. The IRLM is required if the IMS online system is to take part in block-level data sharing. Because the IRLM executes in a separate region, you can plan for a known amount of common storage area (ECSA) to be allocated for use by the IRLM component, or you can retain most of its control blocks in local storage rather than in the common storage area.

Your choice of lock manager is not necessarily permanent. On the IMS procedure, specify IRLM=Y, and give the IRLM z/OS subsystem name on the IRLMNM parameter, to indicate this change. This allows the IMS online system to take part in block-level data sharing.

Using a DL/I separate address space

The DL/I separate address space (DLISAS) is used by the online IMS control program to contain most of the DL/I code and control blocks. For some system configurations, using a DLISAS is required.

You can use a separate address space to contain DL/I code, control blocks, and buffers for full-function databases. To do this, use the local storage option parameter (LSO) on the IMS procedure. After specifying LSO=S on the IMS procedure, you can use the DLINM parameter of the IMSCTRL macro to specify the name of the DLISAS procedure to start.

For the DBCTL environment, a DLISAS is required and generated using the DBC procedure. The LSO parameter, therefore, is not supported. However, in a DB/DC environment, if a DBCTL function is used, you must specify that the DLISAS be used by specifying LSO=S.

DLISAS storage considerations

When you select the LSO=S option, storage is moved to a separate address space. Additionally, most of the PSB pools and the DMB pools are moved to the DLISAS. These pools are not moved if you choose local storage (LSO=Y).

The IMS control program automatically initiates the DLISAS. If either the IMS control program or DLISAS terminates, the other is automatically terminated.

IMS restart procedures do not maintain LSO specifications. For example, an IMS system using a DLISAS can be terminated, and IMS restart procedures can be performed that specify a local storage option.

When you use a DLISAS, the following storage elements are moved into the DLISAS:

- DL/I code
- Database buffers
- DMB pool, both resident and nonresident
- DMB work pool
- Most of the PSB pool, both resident and nonresident
- PI ENQ and DEQ tables (for non-Fast Path systems)

When you use a DLISAS, the following storage elements are in the z/OS common storage area:

- OSAM code
- Log buffers
- Resident intent lists

Defining PSB pools in an IMS system that uses a DLISAS

In an IMS system that uses a DLISAS, two PSB pools exist: one in the z/OS common area (DUMP pool), and one in the DLISAS (DEPTH pool). The DUMP pool contains the communications PCBs, Fast Path PCBs, and the key feedback area of the full-function PCBs. The DEPTH pool contains the DL/I control blocks that are associated with a full-function database PCB (the JCB, for example).

PSBs are slightly larger in IMS Version 10 and later, due to control block size increases. The larger PSBs require more space in the PSB pool. Specify the sizes of these pools with the SASPSB parameter on the BUFPOOLS macro. You can override these sizes with the CSAPSB and DLIPSB parameters on the IMS procedure. The command /DISPLAY POOL PSBP displays usage information for the CSA pool and the DLISAS pool in an IMS system that uses a DLISAS.

For a given PSB, the output of the Application Control Blocks maintenance utility indicates the amount of space required in each pool. The IMS Monitor output reports indicate an out-of-space condition in the DEPTH pool or a wait-for-storage condition if they occur. In these reports, 'DUMP' and 'DEPTH' represent the CSA PSB pool and the DLS PSB pool, respectively.

The Application Control Blocks maintenance utility organizes the PSB so that all data for the DUMP pool precedes all data for the DEPTH pool, regardless of the IMS configurations.

If local storage is used instead, a single PSB pool resides in the z/OS common area. In this case, the PSB parameter on the BUFPOOLS macro and on the IMS start procedure specifies the size of this pool.

To page fix the PSB pool (keep the pool in storage for the long term) specify POOLS=DLMP and POOLS=DPSB in the DFSFIXxx member in the IMS.PROCLIB data set. To page fix the resident PSB pool, include the following module names in the DFSFIXxx member: DFSPSBRs and DFSDLIRS.

Other planning considerations

Accounting procedures with a system that uses local storage option: Accounting procedures that are based on either the IMS system log, the z/OS Resource Measurement Facility (RMF), or the z/OS System Management Facility (SMF) can be affected depending on which storage option is specified. This is because the data reflects the existence of multiple address spaces.

The CPUTIME value that is recorded in the IMS system log is one example of this:

- If the local storage option is used (LSO=Y), only application program processing time is recorded in the type X'07' log record; most DL/I processing time is not included. For some applications, DL/I processing time can represent a large percentage of the total processing time.
- If a DLISAS is used (LSO=S), DL/I processing time is included in CPUTIME.

Because the IMS system log does not indicate which LSO option was specified, do not use CPUTIME values for accounting or comparison purposes when switching options.

For SMF, full-function databases are accounted for in the DLISAS. Fast Path databases and the IMS system data sets are accounted for in the control region.

DLISAS security considerations: If the full-function databases are protected by RACF, the DLISAS procedure must be authorized to access these resources.

Tuning considerations: When tuning your system, consider that the IMS control program consists of more than one address space. You might want to include the control region and the DLISAS in the same RMF performance group so that RMF statistics can be compared with systems that do not use a DLISAS.

Starting the DL/I separate address space

If you choose to use a DL/I separate address space, use the **DLINM=** keyword in the DFSPBxxx member to identify the name of the DLISAS procedure that IMS is to start. Some situations require that the DLISAS procedure be modified, and exit routines that run in the DLISAS have restrictions.

After opting to use a DLISAS by specifying LSO=S on the IMS procedure, use the DLINM parameter of the IMSCTRL macro to specify the name of the DLISAS procedure to start. Unless you change that name, this is the name of the DLISAS procedure that IMS tries to start. You can override this name using DLINM= in the DFSPBxxx IMS PROCLIB data set member that is used to start IMS.

The skeletal procedure DLISAS is built during SMP/E processing and users can copy the DLISAS procedure from the IMS.SDFSPROC to the IMS.PROCLIB data set. Modify this procedure as necessary so that the variable names match what they would have been if generated by Sysgen. Copy the procedure to the SYS1.PROCLIB data set.

Modifying the DLISAS procedure

The following modifications to the DLISAS procedure might be required:

- The JCL DD statements for the full-function databases must be in the DLISAS procedure, not in the IMS procedure. JCL DD statements for Fast Path databases and the IMS system data sets remain in the IMS procedure.
- The specification of the active and inactive ACBLIBs must be identical in both the IMS procedure and the DLISAS procedure. Both the control region and the DLISAS read the ACBLIB. The data sets used must have shared disposition (DISP=SHR), and the concatenation order must be identical.

These ACBLIB data sets can be dynamically allocated by using the DFSMDA member.

- The IMS PROCLIB data set must be defined in both the IMS and DLISAS procedures.

The only parameters passed on the DLISAS procedure are the region type (DLS) and, optionally, the IMSID of the control program to be connected. Pool sizes and database buffering options are specified on the IMS start procedure.

No changes to the dynamic allocation parameter lists in IMS.SDFSRESL are required.

Exit routines running in the DLISAS

Exit routines that run in the DLISAS are entered in cross-memory mode. These exit routines have the following restrictions:

- The DL/I exit routines cannot address storage in the control address space.
- If the DL/I exit routines use the IMS ISWITCH service, they must be changed. A macro specification of TO=DLI, not TO=CTL, must be specified on ISWITCH. The TO=DLI specification performs correctly in all IMS configurations.

Related reference

[“DLISAS procedure” on page 631](#)

The DLISAS procedure initializes a DL/I separate address space (DLISAS).

[“IMS procedure” on page 639](#)

The IMS procedure is an online execution procedure that initializes the IMS DB/DC environment.

[“DFSMDA macro” on page 417](#)

Use the Dynamic Allocation macro (DFSMDA) to build a member (that is, one or more parameter lists) for naming data sets that can participate in dynamic allocation and deallocation. Members include databases, DEDBs, and data sets.

Allocating Message Format Service buffer pool space

The FBP and FRE keywords in the DFSPBxxx member of the IMS PROCLIB data set or the JCL override allow you to reserve storage for efficient processing of communications activity. The amount of storage that is required depends primarily on how much concurrent use of message format blocks is expected, and how many communication lines are active.

About this task

You can control the size of the message format buffer pool and the number of fetch request elements (FREs) using the FBP and FRE keywords in the DFSPBxxx member of the IMS PROCLIB data set or the JCL override. One FRE is required to control each active block. Without a FRE, space cannot be assigned from the message format buffer pool. When estimating the number of FREs, allow at least 10 additional FREs to handle system activity. This eliminates the possibility of delayed response to other terminals. If preallocated FREs are not available, a dynamic FRE is allocated from the general area of the pool. However, dynamic FREs tend to fragment the pool, so avoid using them.

To determine an adequate size for the message format buffer pool:

Procedure

1. Compile a list of the Message Format Service (MFS) blocks, arranging them in DIF/MID and DOF/MOD pairs.
2. Record their sizes and some indication of their frequency (for example, whether they are used by priority or by quick response transactions).
3. Allow space for input/output pairs to be in the pool. Watch for large messages or those with multiple segments, because these might pre-empt small, frequent messages from finding space for their format blocks in the pool, and this would directly affect their response time.

Results

If you use the MFS Service utility to build an index of the DASD addresses that reside in the message format buffer pool during online execution, the index entries also reside in extended private storage.

Use of the message format buffer pool

Message format buffer pools contain MFS control blocks. The control blocks can be loaded using one of two pool manager routines, depending on whether the control block is needed immediately.

MFS control blocks are loaded into the message format buffer pool by one of two MFS pool manager routines: an immediate fetch routine or a prefetch routine. The immediate fetch routine loads a control block that is needed immediately and not already in storage. The prefetch routine is used only if the prefetch option is specified during initialization of the online IMS control region. It is invoked when IMS anticipates the need for a control block; if the block is already in storage, use of prefetch lowers the likelihood that the block is forced out to make room for another block. The use of prefetch requests can improve response time.

When a requested control block is not already in the pool, and its name resides in the resident directory, \$IMSDIR, a single read operation loads the control block into storage. If the name is not in the resident directory, a read of one data set directory block followed by a read of the control block loads the control block into storage. Multiple reads of the data set occur when the size of the control block is greater than either the track size or the z/OS-specified BLKSIZE.

Fetch request elements

Fetch request elements (FREs) are used to represent control blocks that are either already in storage or have been requested for loading into storage. The number of FREs to be defined depends on the number of control blocks that can reside in the pool (a function of pool size) and the number of concurrent requests to load control blocks. FREs defined during initialization of the online IMS control region are allocated contiguously in the buffer pool.

Pool space management

The main objectives of message format buffer pool space management are:

- To keep as many control blocks as possible available in the pool.
- To minimize pool fragmentation.

The MFS pool manager assigns a priority to each fetch request. FREs represent prefetch requests and immediate fetch requests. When required, additional FREs are assigned from available pool space to represent immediate fetch requests. If an FRE is not available when a fetch request is made, a control block of lesser importance is discarded so that its FRE can be used to represent the new request.

When there is not enough pool space to hold a requested control block, a space-freeing algorithm is used to select less important control blocks (based on their frequency of use) for discarding.

Pool statistics

Use the /DISPLAY POOL command to display the contents of the message format buffer pool counters. The statistics displayed for directory and fetch input/output operations and pool space use should help in determining the appropriate pool size and number of FREs.

Declaring online databases

Before a database can be used in the IMS system, it must be declared. Declare online databases to the IMS control region using the DATABASE macro statement, the **CREATE DB** command, or optionally, the PGMCREAT user exit.

The IMS control region allows the application program to access the database and provides DL/I call services. To declare online databases:

1. Define a list of all the physical databases that can be used by the programs by including DATABASE macro statements in the system definition stage 1 input).
2. Include separate statements for the index and data portions of a HIDAM or PHIDAM database.
3. Include one statement for each secondary index database that refers to any other database that is defined to the online system.

The name that you use on the DATABASE macro is the same as the name used on the DBD statement, or the member name in IMS.DBDLIB, for the corresponding physical or index database definition. Do not specify logical databases.

The DATABASE macro allows you to specify a performance option for an individual database. Specify RESIDENT to load the control data management block (DMB), which is needed to access the database, from the active IMS.ACBLIBA/B data set into a separate DMB pool at system initialization. The advantage to this option is that these databases do not incur OPEN or CLOSE penalties caused by competition for space in the DMB pool.

The default value of the DATABASE macro ACCESS keyword is exclusive (EX), which specifies that the database is for exclusive use by this online system.

When the PGMCREAT user exit routine dynamically creates an application program, it can optionally specify to create a database.

Declaring online application programs

Before application programs can be used in an IMS system, they must be declared. Use the APPLCTN macro, the **CREATE PGM** command, or the PGMCREAT user exit to specify a unique Program Specification Block (PSB) name, with which the online system identifies an application.

Declaring application program characteristics

Use the APPLCTN macro or the CREATE PGM command to specify characteristics for application programs that run under the control of DB/DC, DBCTL, and DCCTL systems; examples of these characteristics include:

- The type of application program that is being defined, either batch message or message processing.
- The transaction class for the messages that the program is to receive.
- Whether the application program executes exclusively in Fast Path.

Use the Program Creation user exit routine (PGMCREAT) to specify characteristics for application programs that are scheduled for BMP and JBP dependent regions when the dynamic resource definition (DRD) is enabled. The PGMCREAT user exit only supports the creation of non-Fast Path BMP type programs in DB/DB, DBCTL, and DCCTL systems.

The APPLCTN macro requires that you specify whether the program can be concurrently scheduled into more than one message region or batch message region. Parallel scheduling (SCHDTYP=PARALLEL) permits the program to schedule into more than one region; however, this option requires that processing is truly independent. Each schedule requires its own section of any shared pools. Program isolation activity can increase if the processing has the potential to perform updates in the same database record. You cannot control the ultimate processing sequence for transactions of the same type.

Use the GPSB keyword of the APPLCTN macro or the CREATE PGM command, or the PGMCR_PF1_ GPSBY bit of the PGMCREAT user exit to cause the scheduling process of all environments to generate a PSB that

contains an I/O PCB and an alternate modifiable PCB. This generated PSB can be used, for example, by an application that makes only SQL calls. PSBGEN and ACB generation are not required when a GPSB is used.

Specifying PSB performance options

The IMS online system uses a Program Specification Block (PSB) name to identify application programs. The message processing program uses this same name for identification. The PSB accesses the message input queue and declares any alternative destinations, other than the input source, for messages sent by the program. The PSB defines a complete list of database access intentions down to the segment level, or to the field within the segment. Before access, the PSB is prepared as a member of IMS.ACBLIB. The online system expects this control block to be predefined.

Use the RESIDENT option of the APPLCTN macro or the CREATE PGM command, or the PGMCR_PF2_RESIDENTY bit of the PGMCREAT user exit to specify whether the PSB is to be made resident during system initialization. Using the RESIDENT option eliminates I/O to ACBLIB when the PSB is scheduled. No storage fragmentation occurs in the resident PSB space as it does in the PSB pool, so more efficient use of storage is the result.

If the PSB is resident, the PSB is managed as follows:

- During system initialization, the total space for all resident PSBs is computed. This amount of space is obtained, and all resident PSBs are read from the active Application Control Block Library (ACBLIB) into this space.
- If parallel scheduling is in effect, when the program is scheduled, the resident PSB is allocated for that scheduling if it is not currently allocated to an executing program. If the resident PSB is being used, the PSB pool is searched for an inactive copy of the PSB. If one is found, that copy is allocated and used. If none is found, space for a copy is obtained in the PSB pool, and the resident PSB is copied into that space. The addresses within the copied PSB are then updated based on its new location, and its status related to the former copy is reset.

If serial scheduling is in effect, when the program is scheduled, the resident copy of the PSB is allocated for that scheduling. Multiple copies of the PSB are not required; therefore, copies of the PSB are not required in the PSB pool.

Whether you specify serial or parallel scheduling, the PSB is read only once during initialization.

If the PSB is not resident, the PSB is managed as follows:

- When the program is scheduled, the PSB pool is searched for an inactive copy of the PSB and, if one is found, it is allocated and used. If none is found, space for a copy is obtained in the PSB pool.

If an active copy exists in the pool, it is copied, its addresses are updated, and its status is reset to make it available for use. If no active copy exists, the PSB is read from the active ACBLIB.

When it is necessary to release a PSB in the pool, preference is given to retain only copies of PSBs to minimize ACBLIB I/O.

There is an option to put non-resident ACBs into 64-bit storage. Scheduling with non-resident ACB resources with the 64-bit ACB storage pool works as follows: At the first scheduling of a program, its PSB and any related DMBs are loaded into the 31-bit non-resident pools and are also loaded into the 64-bit ACB storage pool. At subsequent schedulings of this program, ACB members not found in the 31-bit non-resident pools are copied from the 64-bit ACB storage pool to the 31-bit non-resident pools, avoiding an I/O to ACBLIB. If the 64-bit ACB storage pool is full, an LRU algorithm is used to remove old members to make room for new members.

Base your use of the RESIDENT option on the frequency with which the PSB is used. If the frequency would cause at least one copy of the PSB to normally be in the pool even if it were not defined as resident, it should be declared resident. If the PSB is used only occasionally, it should not be declared resident, so that its space in the PSB pool can be released when the PSB is not being used.

Specifying a dynamic PSB

A dynamic (DOPT) PSB is loaded into online storage only when the program that uses it is scheduled in the online system. IMS loads the PSB from either the active ACBLIB data set or, if IMS manages ACBs, the IMS catalog. When the program terminates, the storage for the PSB is released.

To specify the dynamic option for a PSB, use the DOPT parameter on the APPLCTN macro or the CREATE PGM command, or the PGMCR_PF1_DOPTY bit of the PGMCREAT user exit. DOPT and RESIDENT are mutually exclusive parameters. PGMCR_PF1_DOPTY and PGMCR_PF2_RESIDENTY are mutually exclusive parameters.

If you specify the dynamic option, the PSB is managed as follows:

- The PSB is not initialized at system initialization. The PSB does not need to be in the active ACBLIB or the IMS catalog during system initialization.
- When the program is scheduled, the PSB is loaded into the PSB pool from either the active ACBLIB data set or the IMS catalog.
- The space in the PSB pool is released when the program terminates.

You can use the dynamic option in a test configuration. The dynamic option can also provide a PSB to be used with the Online Database Image Copy utility.

Restrictions for dynamic PSBs:

- A dynamic PSB cannot be made resident.
- A dynamic PSB cannot use the 64-bit storage pool.
- A program that uses a dynamic PSB cannot be scheduled in parallel.
- An MPP that is scheduled against a dynamic PSB cannot go through quick reschedule. Quick reschedule allows application programs to process more than the processing limit of messages for each physical schedule.
- An MPP that is scheduled against a dynamic PSB cannot become a pseudo WFI (pseudo wait-for-input). The pseudo WFI option allows an MPP region to remain scheduled until another input message appears.

All databases that are referenced by the dynamic PSB must be defined to the system and their DBDs must be present in the set of active ACBs that are used by the system. If the system uses ACB libraries, the DBDs must be in the ACBLIB data set either at system initialization or after the last online change was performed. If the IMS system manages the ACBs for you, the active DBDs must be in the IMS catalog either at system initialization or after the last **IMPORT DEFN SOURCE(CATALOG)** command was issued. This is because a corresponding dynamic option does not exist for DMBs, even though the PSB is dynamic.

If the IMS system uses ACB libraries, the current ACBLIB data set must consist of two or more concatenated data sets, and the dynamic PSB must reside in any data set in the concatenation other than the first. The concatenated data sets must be of the same format and contain the output from an ACB generation.

If the IMS system uses the IMS catalog to manage ACBs and the dynamic PSBs are generated by the PSB and ACB generation utilities, you add the PSBs to the IMS catalog by using the IMS Catalog Populate utility (DFS3PU00). No concatenation of data sets is required. If the dynamic PSBs are defined by using DDL statements, the PSBs are added to the IMS catalog automatically when IMS processes the DDL.

Declaring Batch Message Processing programs

Use the PGMTYPE parameter of the APPLCTN macro, the BMPTYPE parameter of the CREATE PGM command, or the PGMCR_BMP bit of the PGMCREAT user exit to describe a batch message program in BMP. Include each BMP program as a separate application on its own APPLCTN macro. You declare the BMP program by its use of a PSB, even though the batch JCL allows you to specify a program name that is different from the PSB name.

If a generalized BMP program can execute with different PSBs, you must include APPLCTN macros for all of them. A choice of PSB typically involves several queues that can be processed by the one program. At execution, use the IN parameter to specify an input transaction code.

Related reference

“APPLCTN macro” on page 400

The APPLCTN macro allows you to define the program resource requirements for application programs that run under the control of the IMS DB/DC environment, and for application programs that access databases through DBCTL.

CREATE PGM command (Commands)

PGMCREAT user exit routine type (Exit Routines)

Defining online applications

You can use either IMS commands or the PGMCREAT user exit with dynamic resource definition (DRD) enabled or the IMS system definition macros to define online applications.

IMS online applications consist of individual programs that are scheduled to process transactions. Scheduling must be invoked by JCL for batch message programs. You must identify to the control program both the available programs and the transactions that they process. You must also identify the entire set of databases that the applications can refer to.

If you want data sharing to be supported, be sure that you understand the interaction between the IMSCTRL and DATABASE macro statements and parameters.

The table that follows lists database and application macros, how many are coded, and the purpose of the macro. Although these macros are optional (because of DRD), you must ensure that the appropriate database and application control blocks are available to your IMS system. Otherwise, your IMS system might not work as you want it to.

Table 4. IMS macros used to define online applications

Macro	Number of macros coded	Purpose of macro
APPLCTN	One per PSB	Names the application program that processes the transaction codes specified on the TRANSACT statements. The TRANSACT macro follows the APPLCTN macro in the stage 1 system definition input stream.
DATABASE	One per HSAM, HISAM, HDAM, or PHDAM database; 2 per HIDAM or PHIDAM database; 1 per secondary index database that refers to another database; 1 per MSDB, DEDB	Defines all databases that IMS online control program (and DBCTL environment) manages.
RTCODE	One or more per APPLCTN macro	Specifies the routing codes that the Fast Path Input Edit/Routing exit routine (DBFHAGU0) uses to select a Fast Path application program.
TRANSACT	One or more per APPLCTN macro; 0 for non-message BMP regions	Names the transaction codes to be processed by the application program that is specified on the APPLCTN macro. The APPLCTN macro precedes the TRANSACT macro in the stage 1 system definition input stream.

For a DBCTL environment, you define application programs only for BMP regions by using the APPLCTN macro. For an application program that runs in a CCTL or uses the ODBA interface, use the APPLCTN macro to define the PSB names that the appropriate applications require. The TRANSACT macro is not used in defining a DBCTL system.

The PGMCREAT user exit is valid for DB/DC, DBCTL, and DCCTL environments with DRD enabled. The user exit can specify the dynamical creation of runtime program resources for application programs that run in BMP and JBP dependent regions.

Declaring Fast Path application programs

You use the APPLCTN macro or the CREATE PGM command to declare the Fast Path application program name and whether it is a message-driven program. The PSB keyword is used to specify the PSB name, which is the same name as that of the message-driven program.

Declaring program processing

When you specify the PGMTYPE keyword value as TP, you designate the application program as message-driven. At the same time, you can specify FPATH=YES or FPATH=SIZE if you are certain the application program is always to be executed under Fast Path control. FPATH=SIZE establishes an Expedited Message Handler Buffer (EMHB) size for the application program. Specify FPATH=SIZE for the application program if its input or output message requirements are larger than the system default.

One special effect of explicitly declaring the application program to be a message-driven Fast Path program is that the subsequent TRANSACT macro automatically specifies the transaction to be Fast Path exclusive. The sequence of APPLCTN and TRANSACT macros also causes a routing code, with the same value as the transaction code, to be automatically generated in a routing code table; the routing code indicates that this is for a Fast Path-exclusive transaction.

If you do not explicitly declare the application program to be Fast Path, the sequence of APPLCTN and TRANSACT macros (when FPATH=SIZE or FPATH=YES is specified on the TRANSACT macro) identifies a Fast Path-potential transaction.

Most of the other APPLCTN keywords have the same use as for DL/I application programs. However, for the PGMTYPE keyword, the value of BATCH is not used for Fast Path programs. Also, the OVLY parameter and the option to declare a message class are not valid for Fast Path application programs. Parallel scheduling is specified with the keyword value SCHDTYP=PARALLEL if the message-driven program is to occupy more than one Fast Path dependent region for a balancing group.

Adding routing codes

You use the RTCODE macro or the CREATE RTC command to declare any routing codes that are to be associated with the program specified in the preceding APPLCTN macro statement. You need one RTCODE statement for each routing code. The name can be from 1 to 8 alphanumeric characters. It can be a duplicate of a transaction code or an LTERM name, but each routing code must be unique. These routing codes are in addition to those automatically generated by the APPLCTN-TRANSACT macro sequence.

You use the INQUIRY keyword to specify that, when this routing code is used to send a transaction to a balancing group, the program must use inquiry-only processing. INQUIRY=YES should be specified only for those transactions that do not cause a change to any database.

Defining IMS transactions

An IMS transaction is a message destined for an application program. In defining a transaction to IMS, you identify several characteristics, including scheduling rules, exceptions to those rules, transaction codes, output limits, and more.

Use the TRANSACT macro (or the CREATE TRAN command) to define the overall online IMS system response to incoming messages.

With the TRANSACT macro, you can relate one or more transaction codes to the PSB that was named in the preceding APPLCTN macro.

The TRANSACT macro is supported in the DB/DC and DCCTL environments, but not the DBCTL environment. The following table summarizes transaction characteristics that are declared in the TRANSACT macro:

Note:

The CREATE TRAN command can be used instead of the TRANSACT system. To learn more, see [CREATE TRAN command \(Commands\)](#).

Table 5. Summary of transaction characteristics defined with the TRANSACT macro

Transaction characteristic	TRANSACT parameter	Parameter description
What are the transaction identifiers?	CODE	Identifies unique transaction codes.
	SYSID	For Fast Path, also declares a possible routing code. Identifies remote system and local system.
What rules govern program scheduling for this transaction?	DCLWA	Log write-ahead option.
	PARLIM	Queue count that triggers parallel scheduling.
	PRTY	Normal priority and alternate priority when queues build up.
What exceptions are there to the scheduling rules?	MAXRGN	Limit for number of regions that can be scheduled per transaction.
	PROCLIM	Limit for number of input messages processed or the processing time.
What type of processing?	INQ	Update database or not. Recovery required or not.
	FPATH	Fast Path potential transaction.
	MODE	Whether or not transactions are autonomous.
	MSGTYPE	Multisegment code or not. Response before more input or not.
	ROUTING	Whether or not program is aware of originating system.
	SERIAL	Serial processing of transaction.
	SPA	Conversational transaction.
What edit operations?	WFI	Wait for input transaction.
	EDIT	Whether or not to convert input data to uppercase. Name of an input edit routine.
What limits on output?	SEGNO	Maximum segments per transaction.
	SEGSIZE	Maximum segment size.

Configuring IMS transactions

From the application, you need to determine how a transaction is to be processed and how it looks to the user. The following table helps you specify the correct parameters on the TRANSACT macro.

Table 6. Transaction configurations and recommended parameters

Transaction configuration	Recommended keyword parameter
Declares that the program is continuously available and not reloaded each time it is scheduled.	WFI

Table 6. Transaction configurations and recommended parameters (continued)

Transaction configuration	Recommended keyword parameter
Specifies that the transaction is an inquiry, and its database processing does not cause any updates. No recovery at system restart is required.	INQ=(YES,NORECOV)
Declares that the transaction is an inquiry, but update processing might occur. Recovery at system restart is required	INQ=(NO,RECOV)
Declares that a response to an input message is the next event.	MSGTYPE=(RESPONSE)
Declares that the response to an input message allows multiple message input actions.	MSGTYPE=(NONRESPONSE)
Specifies that database buffers are written to direct access upon each request for a new message. SNGL is forced for WFI applications.	MODE=SNGL
Specifies a group of transactions that are processed together.	MODE=MULT
Declares that the transaction is conversational.	SPA=
Declares the scratchpad area size in bytes.	SPA=(<i>size in bytes</i>)
Declares that an input message edit routine is present. The member name of the bound module in IMS.USERLB (or equivalent library) is <i>name</i> parameter. UC specifies that input is translated to uppercase before presentation to program.	EDIT=(UC, <i>name</i>)
Protects output message queues by testing the size of an output segment.	SEGSIZE= <i>size</i>
Protects output message queues by testing the number of segments issued per transaction processed.	SEGNO= <i>number</i>

IMS Connect transaction expiration support

If an expiration time is specified in IMS, transactions can expire and be discarded if IMS does not process them before the expiration time is exceeded.

The transaction expiration time for a transaction is set in the definition of the transaction in IMS and is not specific to OTMA. In IMS, you can set or modify the expiration time for a transaction in the following ways:

- When a transaction is defined during IMS system definition, by specifying the **EXPRTIME** parameter in the TRANSACT stage-1 system definition macro.
- When a transaction is created during runtime by using dynamic resource definition, by specifying the **EXPRTIME** keyword on the **CREATE TRAN** type-2 command.
- For a transaction created by the Destination Creation exit routine (DFSINSX0), the exit routine can set the expiration time.
- For an existing transaction, by specifying the **EXPRTIME** keyword on the **UPDATE TRAN SET(EXPRTIME)** type-2 command. Dynamic resource definition does not need to be enabled.

A transaction expiration time set by IMS Connect overrides any transaction expiration time that is specified in the definition of the transaction in IMS.

Defining Fast Path transactions

The TRANSACT macro (or the CREATE TRAN command) is used to identify the transaction code and processing characteristics for a Fast Path transaction. The code is specified with the CODE keyword, and, even though the scheduling of Fast Path programs uses the routing code for its queue selection, the code must be a unique name among the set of transactions, LTERMs, and link names.

Use the FPATH keyword on the TRANSACT macro to signify that the transaction is a *Fast Path-potential* transaction (meaning it can run in either an IFP or a full-function region such as MPP). Specify a parameter value of FPATH=YES. You only need to do this when the APPLCTN macro that precedes the TRANSACT macro does not use an FPATH=SIZE parameter value. The FPATH operand on the TRANSACT macro is ignored if your preceding APPLCTN macro explicitly specifies a message-driven application program. This parameter generates a routing code in a table identical to the transaction code and marks it as Fast Path potential.

The following keywords for the TRANSACT macro differ slightly depending on whether they are used to define DL/I transactions or Fast Path transactions:

MSGTYPE

Specifies a single- or multiple-segment message and its processing mode. Use parameter values SINGLSEG and RESPONSE, because Fast Path transactions must be single segment and response mode.

INQUIRY

Specifies an inquiry transaction. You must use the default parameter value RECOVER, because these transactions are processed in the same way as other Fast Path transactions.

EDIT

Specifies translation to uppercase and the presence of an input message edit routine. The latter option is not valid for Fast Path-exclusive transactions. For Fast Path-potential transactions, the edit routine is only invoked if the transaction is routed to IMS.

PROCLIM

Specifies the maximum processing time. For message-driven programs, PROCLIM is the limit for one transaction and uses the real elapsed time, because the terminal is in response mode. The count parameter is ignored.

FPBUF

Specifies the Expedited Message Handler Buffer (EMHB) size for transactions.

Planning a scheduling algorithm

A scheduling algorithm determines how application programs are scheduled to handle the load on the queues.

The basic approach to controlling an online IMS system with loaded queues is to let the demand control the scheduling of programs into a reasonable number of message regions.

You specify a working set of application-dependent regions that can execute concurrently with the first parameter of the MAXREGN keyword on the IMSCTRL macro. The MTO can use the /START command to dynamically allocate other dependent regions. Up to 999 dependent regions (the maximum allowable number permitted by IMS) can be allocated. For a DBCTL environment, the MAXREGN keyword defines a working set of BMPs, JBPs, and CCTL region threads, or application programs, that can run concurrently. Other BMP and JBP regions can be dynamically started, up to the maximum allowable number, using the /START command. The DBCTL environment does not have any transactions, so information about transactions does not apply to DBCTL.

Scheduling algorithms in an IMSplex

IMS application programs are run either serially or in parallel and must be scheduled accordingly in an IMSplex.

- Serial application programs can only run in one message region or batch message region at a time.
- Parallel application programs can run concurrently in more than one message region or batch message region.

IMS users with an IMSplex with shared queues might want to prevent the concurrent scheduling of serial application programs. The IMS Resource Manager (RM) creates a serial program resource the first time a serial application program runs. If a second message later requires the same serial application program,

RM attempts to create a second serial program resource structure. Because the program resource exists, the second recreation fails, and the second IMS cannot schedule the serial application program to run.

Users with an IMSplex and shared queues can prevent serial application programs from being scheduled concurrently.

Grouping application transactions in DB/DC and DCCTL environments

When you group transactions and associate them with a particular message class and region, the criteria you use to group them can include virtual storage considerations, PSB characteristics, and priority of service.

You must associate different groups of transactions with a particular message class that can be assigned to a region. (Batch message programs are allocated in their own region.) Criteria might be the virtual storage the message processing programs require, the PSB characteristics they share, or the priority of service for the end user. Lay out the transactions in a summary matrix. An example of this information summary for a vehicle routing application is shown in [Table 7 on page 117](#).

Table 7. Example of transaction grouping

Transaction Group	Transaction Code	Transaction Rate	Program	Preload	REGN	Processing Mode
Driver log	TRLOG	1000 /day	PGMA	-	520 KB	SINGLE
Driver changes	TRCHG	300/hr	PGMB	PRLD	200 KB	MULTIPLE
Enter load or job	TRLOAD	50/hr	PGMC	-	520 KB	CONVERSATION
Status of job	TRSTAT	20/hr	PGMD	-	520 KB	SINGLE
Optimize route	TROPT	10/day	PGME	-	400 KB	(SINGLE) BMP
Get driver route	TRROUT	50/hr	PGMF	-	100 KB	SINGLE

One solution for this group of transactions is to define a message class for TRLOG, TRLOAD, and TRSTAT, which seem to be frequently used, and assign them to a message region. The BMP has its own region. The driver control transactions, TRCHG and TRROUT, can be assigned to another message class, because they have similar virtual storage requirements and one of them needs the program preload function specified on the region JCL.

The process of grouping transactions becomes more complex when you have competing application programs. An additional factor to consider is the database processing intent. You should attempt to combine compatible application programs (such as application programs that are inquiry only) into groups before assigning them a message class and individual priorities.

Stopping transactions and PSBs because of unavailable data

In a DB/DC environment, IMS stops the transaction type if most messages being processed are failing because they are encountering unavailable data.

In a DB/DC environment, IMS stops the transaction type if most messages being processed are failing because they are encountering unavailable data. One abort is counted each time the program aborts due to abend U3303 and the message in process has not previously been placed on the suspend queue. Two aborts are subtracted each time a program goes through commit processing. However, if this results in a negative number, two aborts are not subtracted. If the total number of aborts exceeds 10, the transaction is stopped with a USTOPPED condition.

The transaction is stopped by USTOPPED if abend U3303 occurs while processing the message and SERIAL=YES is specified for the TRANSACT macro.

When the transaction is stopped by USTOPPED, messages from this queue are not scheduled for processing. Incoming messages continue to be queued on the normal queue.

In a DBCTL environment, after ten U3303 abends IMS stops the PSB instead of the transaction, preventing further rescheduling of the application program.

Assigning message class and initializing a region in DB/DC and DCCTL

The message class that is assigned to a transaction determines into which message region an application program is loaded.

Each message (transaction code) is assigned a class using the third parameter of the MSGTYPE keyword on the TRANSACT macro. If the class is not specified this way, the value on the PGMTYPE keyword of the APPLCTN macro is applied. This class assignment determines into which message region an application program is loaded. When the IMS message regions are started, they are assigned from one to four message classes. When a message region is assigned more than one class, the scheduling algorithm treats the first class specified as the highest priority class, and each succeeding class is treated as a lower-priority class.

If more than one class is specified, message selection is processed as follows. The first class specified is scanned, in transaction-priority sequence, for waiting messages. If no messages are waiting for the first class, the second and following classes are also scanned in priority sequence. If messages are waiting in the first class, the highest-priority message is selected for scheduling.

Message priorities within message classes in DB/DC and DCCTL

When developing your scheduling algorithm, you must know the priority and transaction code for each message class. This information helps you set up test levels of queue loading.

To develop your scheduling algorithm, draw a matrix that lists each priority and transaction code. Group all those transactions that belong to a class. You can then test the contents by setting up test levels of queue loading and apply the class and priority algorithms. Such a matrix is illustrated in [Table 8 on page 118](#).

Table 8. Matrix for message classes and priorities

Class	Priority	Transaction Code	PSB Name
001	5	TRANX	PGMX
	3	TRAND	PGMD
	2	TRANA	PGMA
003	10	TRANY	PGMY
005	10	TRANC	PGMC
	5	TRANB	PGMB

If an available region specifies a message class priority of 1, 5, 3 and if two transactions are in each queue, PGMX is scheduled first and both TRANXs are processed. If no other transactions are received, the order of processing is TRAND, TRANA, TRANC, TRANB, and TRANY.

Notice how the order of message class prioritizing (specified in the region JCL) causes class 3 to be processed last.

If another message region that specifies message classes 1, 5, 3 is started during the processing of TRAND, the region begins processing with PGMA. Whichever region completes message class 1 transactions first schedules PGMC.

Selection priorities for transactions in DB/DC and DCCTL environments

When more than one transaction of a given type is waiting to be scheduled, the specified transaction scheduling priority determines which transaction code is selected. It does not determine which transaction is scheduled. Only the tests of the transaction's readiness for scheduling, which occur after selection, determine if the transaction queue is allocated to an application program.

Selection priorities are useful for influencing the response time to input transactions and for load balancing. Two priorities can be specified:

- Normal priority
- Limit priority

Related to the normal and limit priorities is the *limit count*. When the number of input messages of a specific transaction type waiting to be scheduled is equal to or greater than the limit count, the normal priority is reset to the limit priority value.

The priority of a transaction code causes it to be selected either before or after other transaction codes. You specify the numeric priority with the PRTY keyword of the TRANSACT macro. Values can be selected in the range 0 - 14; a value of 0 specifies the transaction is not eligible for automatic scheduling. If multiple transaction codes are at the same priority, they are selected on a first-in/first-out basis. So, if multiple transaction codes are at the same priority and class, with many messages already enqueued for each transaction code, the first scheduled transaction code processes all of its messages before the next, equal priority, and class transaction code are scheduled.

You can raise the priority normally used for a transaction after a certain level of the queue is reached. In this way, you can give the transaction an increased chance of being scheduled. Another case occurs when a program requires significant program loading time or initialization and is then followed by a batch-like processing of a group of transactions.

Suppose the transaction TRANB in Table 8 on page 118 is assigned a limit priority of 14 if the number of queued transactions rises to 10. When message class 5 is available for scheduling and the queue counts for TRANC and TRANB are 18 and 10, respectively, the first program scheduled is PGMB. The processing of TRANB stays at priority 14 until all 10 transactions, and any others added to the queue, are processed. Then TRANB reverts to a normal priority of 5.

It is possible that more messages are added to the queue while the transaction is waiting or in process at the limit priority. The normal priority is not restored until all messages enqueued on the transaction code are processed. The priorities are selection priorities, not execution priorities. After a transaction has been selected for scheduling, the selection priorities have no influence until it is again recognized to be waiting for scheduling.

Limit priority can be in the range 0 - 14. Limit count has a default of 65535 and a valid range of 1 to 65535. You specify limit priority and the queue count as the second and third parameters of the PRTY keyword on the TRANSACT macro. If you do not require this priority override technique, code the limit priority equal to the normal priority, and code the limit count as 65535.

Another way to use the selection priorities is to declare a normal priority value of zero. Zero priority is a null or "not eligible for scheduling" level. Messages accumulate until the limit count is reached; limit priority takes effect and the message is eligible for scheduling. This technique is called *batching messages*.

The effectiveness of the selection priority assignments is related to how frequently the selection process occurs.

Processing limits for messages in DB/DC and DCCTL environments

To influence the frequency with which scheduling selection occurs, you can set processing limits for messages. These limits set the length of time that application programs wait.

By setting processing limits, you can influence the frequency with which scheduling selection occurs. During the time between each scheduling, processing continues in the message regions. Meanwhile, messages are accumulating in the message queues. As messages accumulate, the interactive effects introduced by new message types and the changing of selection priorities are rearranging the order of waiting transaction codes. Conceivably, while a large queue of messages is being processed, important activity assigned to a high-priority transaction code is waiting.

When the program processes a large queue of messages and updates database segments, other application programs trying to access an updated segment are placed into a wait state. The length of time that the other application programs must wait depends on whether the updating program is processing its queue in multiple- or single-message mode.

To allow controlled reentry to the message scheduling selection process, specify a processing limit count for each transaction code. Each time a scheduled (processing) program requests a new message, the limit count is checked. When the number of requests exceeds the limit count, IMS determines if the region is eligible for quick reschedule.

- If the region is not eligible for quick reschedule, the application program completes its processing. If the current transaction code is at the same priority level as other queued transaction codes, the current code is placed last in the list.
- If the region is eligible for quick reschedule, the application program remains active and the next message is returned to the application program for processing.

Quick reschedule for regions in DB/DC and DCCTL environments

Quick reschedule allows application programs to process more than the processing limit of messages for each physical schedule. Quick reschedule eliminates processing overhead caused by unnecessary rescheduling and reloading of application programs.

When a region undergoes quick reschedule, the message count that is compared with the processing limit count is reset, the accounting (X'07') and scheduling (X'08') log records are written, and the next message is returned to the application program for processing.

A region can undergo quick reschedule only when:

- No other work of equal or higher priority exists for the region to process
- The same transaction would be scheduled if the application program terminated and the dependent region went through rescheduling.
- The region is an MPP processing a MODE=SNGL transaction
- The processing limit count is greater than zero
- The PSB is not allocated with the dynamic PSB option (DOPT)

Flags in the accounting and scheduling records written during a quick reschedule indicate that the records do not include actual program termination and scheduling times. These records are written for accounting purposes only. Restart and backout do not use these records.

Pseudo WFI option for MPP regions in DB/DC and DCCTL environments

The pseudo WFI (pseudo wait-for-input) option allows an MPP region to remain scheduled until another input message appears. With pseudo WFI, unnecessary application program termination and rescheduling can be eliminated.

Normally, if an MPP region is scheduled for a transaction and no more messages for that transaction exist, the application program terminates. Frequently, another message appears for the same transaction after the program is terminated. Processor usage is increased because of unnecessary termination and rescheduling of that application program.

Pseudo WFI is specified with the **PWFI=** parameter on the MPP region startup procedure. When **PWFI=Y** is specified, the processing limit count is greater than 0, the PSB is not allocated with the dynamic PSB option (DOPT) and no more messages are queued for the current **MODE=SNGL** transaction, IMS checks for other work for the region to process. If no other work is available, the region waits until another input message appears. This is *wait-for-input* mode.

When the next input message is for the currently scheduled transaction, the message is returned to the application program with a status code of "blank-blank".

When the next message is not for the currently scheduled transaction, termination and rescheduling occur.

In certain circumstances, regions that are in wait-for-input mode will be posted and a QC status code is returned to the application program. These circumstances include:

- Commands that involve stopping, starting, locking, unlocking, or purging
- Commands that involve assigning a database, region, transaction, or class
- The **UPDATE PGM START(REFRESH)** command

Note: The **UPDATE PGM START(REFRESH)** command is not supported for MPP regions where the program is loaded by the DFSMPLxx PROCLIB member.

When application program changes are made in IMS.PGMLIB, you can issue the **UPDATE PGM START(REFRESH)** command to post the MPP PWFI regions so that a refreshed copy of the application program can be obtained when the program gets scheduled again. By using this command, you do not have to find all of the regions that the program is scheduled in and to stop those regions manually. The **UPDATE PGM START(REFRESH)** command is supported for programs scheduled in MPP PWFI regions that have the program scheduled in them and the program is not preloaded by the DFSMPLxx PROCLIB member, .

The following circumstances also cause similar problems:

- An intent conflict scheduling failure might occur as a consequence of either a local or global load balancing algorithm decision. This causes all PWFI regions to be posted and QC status codes to be returned to the application programs.

The global load balancing algorithm is a feature of Sysplex Serial Program Manager (SSPM).

- A resource enters the OLC PREPARE phase. This causes all PWFI regions to be posted and a QC status code to be returned to the application programs.
- A program or transaction is stopped as a consequence of a dependent region abend. This causes all PWFI regions to be posted and QC status codes to be returned to the application programs that belong to regions with stopped programs or transactions.

Regions that cannot be scheduled because of a lack of pool space can also post regions currently in pseudo WFI in an attempt to terminate them. This frees pool space so that the failing region can schedule.

Processing transactions against unavailable data in DB/DC and DBCTL environments

When an application program attempts to access unavailable data, IMS abends the application program. Use the INIT call to prevent application programs from being scheduled when a database is unavailable.

IMS schedules an application program even if that application program might try to access an unavailable database. The application program can be *sensitive* or *insensitive* to unavailable data. To be sensitive, it must issue the INIT call. This requests that a status code is returned in the PSB if a subsequent call requires access to data that is unavailable. If the application program has not issued the INIT call and a call requires access to unavailable data, IMS abends the application program with U3303, and backs out any updates it has made.

After ten U3303 abends, IMS takes the following action:

- In a DB/DC environment, IMS stops the transaction with a USTOPPED condition.
- In a DBCTL environment, IMS stops the PSB, preventing further scheduling of the application program.

The disposition of the transaction depends on whether it is serial or not. Serial transactions are those that must be processed in the order of arrival. If it is serial, the processing of any transaction of its type is stopped. If it is not serial, only the processing of this particular transaction is stopped.

Data can be unavailable for these reasons:

- The database is stopped, locked, or unavailable for update.
- A lock cannot be obtained, because it is held by a failing component in a data sharing environment.
- In an XRF environment with block-level data sharing, the takeover system initiated new work before the data sharing configuration is revalidated.

IMS tries to resume transaction processing when any of these events occurs:

- A /DEQ SUSPEND command is issued.
- A /START TRAN command is issued for a transaction type that is stopped or that has stopped messages.
- A /START DATABASE command is issued for a database that is unavailable and in the intent list of the program requesting the transaction.
- A failing IRLM is reconnected.
- An emergency restart completes.
- An XRF takeover completes.
- A sharing IMS system completes a batch backout.

Scheduling transactions using the suspend queue

Messages can be placed on or removed from the suspend queue based on conditions that you describe. An example of these conditions can be user abend U3303, which occurs when a message attempts to access unavailable data, and USTOPPED transactions, which is when a transaction is stopped because most messages being processed are failing because they are encountering unavailable data.

When scheduling transactions using the suspend queue, you must describe the following:

- The conditions that result in messages being placed in or removed from the suspend queue
- The conditions that result in setting or resetting the transaction stopped because of unavailable data (USTOPPED)

When messages are placed in the suspend queue

If the program processing the message attempts to access data in a database that is unavailable, and the program has not issued the INIT call indicating that it can accept a status code that data is not available, the program is pseudoabended with abend U3303. The disposition of the message in process at the time

of abend U3303 depends on whether the transaction type being processed requires serial processing. If the transaction type does not require serial processing, the failed message is placed in the suspend queue. If the transaction requires serial processing, the message is returned to the normal queue and the transaction is USTOPPED.

Data might be unavailable for any of the following reasons:

- The database is stopped, locked, or not available for update.

Programs are scheduled even when full-function databases are not available, or when they are available as read only. If a program issues a DL/I call that requires access to one of these databases, the program encounters unavailable data.

- A lock on the data cannot be obtained because it is held in retained state.

In a block-level data sharing environment, it might not be possible to communicate with the sharing system because the sharing IMS has failed, the sharing IRLM has failed, or communication with the sharing IRLM has failed. The IRLM being used by the surviving IMS system retains knowledge of the locks that were held by the IMS system with which communication is temporarily unavailable. These locks are held in retained state. A similar condition can exist in a DBCTL environment when a thread failure occurs.

- In an XRF and block-level data sharing environment, the takeover system initiates new work before the data sharing configuration is revalidated.

At the time of an XRF takeover, databases that can be shared at the block level are temporarily made unavailable until the data sharing configuration has been revalidated. If programs attempt to access these databases before the revalidation completes, they encounter unavailable data.

When messages are removed from the suspend queue

A separate suspend queue exists for each transaction type. Messages are never scheduled for processing from the suspend queue. To be scheduled, the message must be transferred to its normal queue. Some conditions cause the messages on suspend queues for all transaction types to be transferred to their normal queues. Other conditions cause the messages for specific transaction types to be transferred to their normal queue.

The conditions that trigger the transfer of all messages from the suspend queues, and the rationale for transferring the messages when that condition occurs, are:

- The /DEQ SUSPEND command is issued.

The operator requested it.

- IMS emergency restart is completed.

While the IMS system is down, a sharing IMS might notify the system to drain its suspend queues.

- A sharing IMS system notifies the system that the sharing IMS system has completed an emergency restart or a batch backout.

Messages are transferred for the same reason as when these conditions occur on the local system.

- IRLM is reconnected.

When the IRLM failed, messages that were in process at the time of failure were abended with abend U3303. Attempts to access data that the failing IRLM locked also result in abend U3303. When the IRLM is reconnected, these messages are scheduled again.

- XRF takeover has completed.

While the takeover is in process, a notification from a sharing IMS might have been missed, and databases that can be shared at the block level are temporarily unavailable until the revalidation to DBRC has completed.

The following conditions trigger the transfer of messages for specific transactions to the normal queue:

- A /START TRAN command is issued. This causes the messages for the started transaction to be transferred to the normal queue from the suspend queue.

- A /START DATABASE command is issued. This causes the transfer of messages for transactions in which the program processing the transaction has access to the started database.

Parallel scheduling of applications and transactions

IMS can schedule the same application program and the same transaction in multiple message regions. Designate the application program and the transaction for parallel scheduling using the SCHDTYP keyword on the APPLCTN macro or the CREATE PGM command.

By designating an application program as a parallel-scheduled application program, any transaction processed by that program can be scheduled in multiple regions.

When a transaction is available for scheduling but is already scheduled in another region, IMS checks whether the transaction can be scheduled in parallel. The PARLIM value of the TRANSACT macro specifies the number of messages that should be enqueued before another region is scheduled. This value is multiplied by the number of regions already scheduled for this transaction. If the result is less than the number of messages enqueued, another region is scheduled for the transaction unless MAXRGN is exceeded. If the region cannot be scheduled for internal reasons (database intent), the next transaction within the class is scheduled.

If the PARLIM value is zero and more messages are in the queue, another region can be scheduled. To prevent one transaction from monopolizing all available regions, use the MAXRGN= parameter on the TRANSACT macro. A non-zero value for MAXRGN specifies the number of MPP regions that can be scheduled. In addition, you can use the SERIAL option of the TRANSACT macro to process transactions in the order they arrive. IMS limits the processing to this time sequence. If data required by the transaction is unavailable, this causes IMS to stop scheduling this transaction type.

For a DBCTL environment, BMP regions and CCTL threads can schedule a PSB simultaneously when the APPLCTN macro or the CREATE PGM command's SCHDTYP keyword is defined as PARALLEL. If a PSB is not defined as PARALLEL and is already scheduled by a BMP or CCTL thread, new schedule requests for that PSB fail.

Scheduling for BMP processing

Input transactions to batch message programs do not need to be assigned a competitive priority. BMP regions are manually scheduled.

Because BMP regions are scheduled manually, the input transactions to a batch message program do not need to be assigned a competitive priority. Specify a priority value of zero for both normal and limit priority, and coordinate a message class designation with the BMP region JCL.

Assigning priorities for programs with exclusive intent

Application programs that have exclusive use of a segment type are not concurrently scheduled with other application programs that are sensitive to the same segment type. Conflicts in scheduling can occur if the same segment type is declared exclusive by more than one application program.

When a program's PSB includes exclusive use of a segment type, the program is not scheduled concurrently with any other program that is sensitive to the same segment type. Similarly, when a program executes with exclusive use of segment types, other programs that include sensitivity to any of those segments are not scheduled concurrently. Exclusive intent does not use enqueue/dequeue serialization. Programs have exclusive intent declared by PROCOPT=E on a SENSEG or program communication block, or PCB, statement within the PSB generation—if the option K, for key sensitivity, is not appended. Conflicting actions occur only if the same segment type is declared by at least one of two programs intending to reference a segment exclusively.

One case in which programs require exclusive intent occurs when a program that uses HSAM in its PSB is scheduled.

Use care when assigning priorities for programs with exclusive intent. Even if a program is selected for execution, a conflict with its processing intent and that of an already-executing program causes the transaction to drop out of the selection process until the next program termination or region start event.

Exceptions to the use of program isolation are programs that use the PROCOPT=GO option. These programs can retrieve segments that have been altered or modified by programs that are still active. Those changes might be subject to backout. The programs might not update the segments, and there is no enqueue on the segments when the programs retrieve them.

Scheduling for CPI-Communications-driven programs

Scheduling information for LU 6.2 CPI-Communications-driven application programs is defined in a TP_Profile entry that is managed by APPCMVS.

When APPC/IMS recognizes a CPI-Communications-driven application program for the first time after restart, it dynamically builds an IMS transaction. IMS dynamically builds the definition for CPI-Communications-driven application programs when a transaction is presented for scheduling by APPCMVS, based on the APPCMVS TP_Profile definition after IMS restart. A dynamically built transaction is not checkpointed unless SYNCLVL=SYNCPT and IMS is participating in a protected conversation.

Defining terminals with data communication macros

By using different combinations of the 16 macro statements used for the IMS data communications facilities, you can define terminals to be attached to the IMS online system.

Restriction: This topic does not apply to DBCTL.

Most of the system definition stage 1 input is comprised of declarations that define terminals to be attached to the IMS online system. Sixteen macro statements describe all of your IMS system's data communication facilities. By using different combinations of these statements, you can create macro sets that support:

- Non-VTAM devices
- Multiple Systems Coupling
- VTAM

If you are using IMS Extended Terminal Option (IMS ETO) of IMS TM to define terminals, you can reduce the number of macro statements that are required for system-defined VTAM terminals. For more information about IMS ETO, refer to [“Including IMS ETO in the IMS system”](#) on page 132.

[Table 10 on page 128](#) provides an overview of each macro set and a detailed description of the macro statements in each macro set. Use this information and the accompanying configuration diagrams to define your terminals. Each of the terminal types and hardware options has equivalent parameters in one or more of the terminal-related macros in the stage 1 system definition input.

In some instances, you must prepare the same macro statements for more than one of the macro sets. Refer to the section [“Coding IMS macros that define the system”](#) on page 2 for information about the order of entering the macro sets into the assembler input stream. IMS issues stage 1 system definition output warning messages and does not complete system definition if the macro sets are not entered in this order.

Defining VTAM terminals

If your IMS system uses VTAM, use the COMM, NAME, SUBPOOL, TERMINAL, TYPE, and VTAMPOOL macros to describe the VTAM data communication facilities.

If your IMS system uses VTAM, prepare a set of VTAM macro statements to describe the VTAM data communication facilities. The number of sets you must prepare depends on the hardware configuration of your IMS system.

To add VTAM support, specify an ONLINE or ALL system definition on the IMSCTRL macro statement.

You must enter the macro sets in your IMS system stage 1 input deck in the order specified in “Coding IMS macros that define the system” on page 2. IMS issues stage 1 output warning messages and does not complete system definition if the macro sets are not entered in this order.

All non-VTAM data communication specifications must precede the VTAM macro set in your IMS system definition stage 1 input deck; a stage 1 output warning message occurs if the VTAM macro set is not the last physical set. If an MSC macro set is part of your system definition, it must precede the VTAM macro set, or your system definition does not complete. The following table lists macros for defining VTAM terminals.

Table 9. VTAM data communication macros

Macro	Number of macros coded	Purpose
COMM ¹	One only per IMS system definition	Specifies general communication options not associated with any particular terminal type.
NAME	One or more for each physical terminal or component	Specifies the logical terminal name for physical terminals of the type specified by the TERMINAL or SUBPOOL statement.
SUBPOOL	One for each dynamically allocated session	Defines logical unit type 6 (LU 6.1) subpools that can be dynamically allocated within the VTAMPOOL.
TERMINAL	One for each terminal or component; must follow the TYPE macro	Provides the characteristics of the physical terminal type that is specified in the TYPE statement.
TYPE	One for each terminal type	Specifies a group of VTAM terminals of the same type.
VTAMPOOL	One or more per SUBPOOL; the only purpose for multiple VTAMPOOL statements is to facilitate the documentation of the intended use of the logical terminal group	Defines subpools of logical terminals to be dynamically allocated to LU 6.1 sessions.

Note: ¹ You can specify only one COMM macro in an IMS system definition. The COMM macro is required for the VTAM macro set.

The following figure is an example of coding for a group of 3270 VTAM terminals.

```

TYPE UNITYPE=3270,MODEL=2,PTRSIZE=132,OPTIONS=COPY
TERMINAL NAME=CT3275,UNIT=3275,COMPT=PTR1,MODEL=1
NAME VT3275
NAME VT3275P,COMPT=PTR1
TERMINAL NAME=CT3277A
NAME VT3270A
TERMINAL NAME=CT3277B
NAME VT3270B
TERMINAL NAME=CT3277C,MODEL=1
NAME VT3270C
TERMINAL NAME=CT3277D,UNIT=3284
NAME VT3270P1
TERMINAL NAME=CT3277E,UNIT=3286
NAME VT3270P2

```

The following figure shows the configuration for 3270 VTAM terminals using the VTAM macro set.

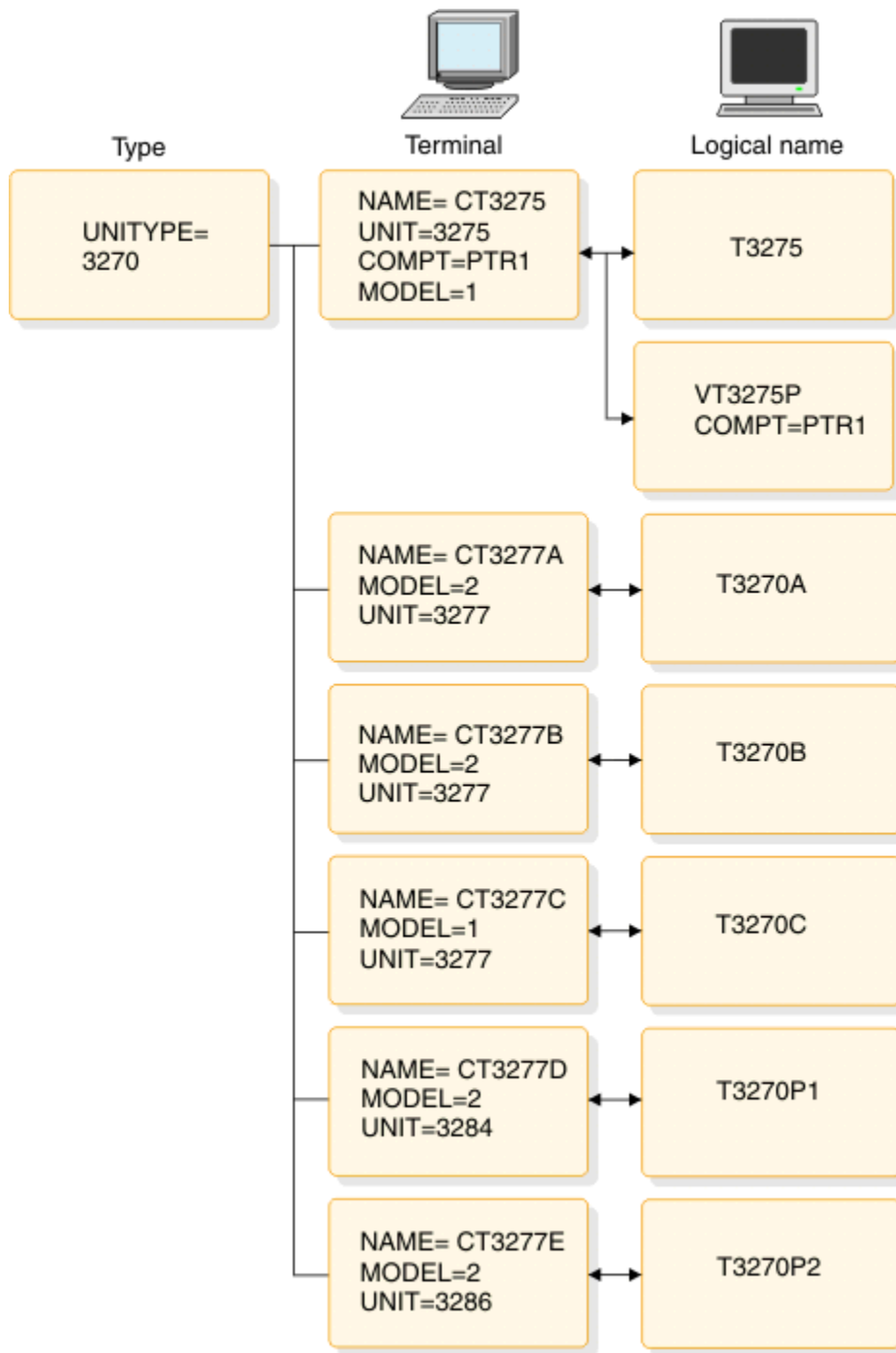

Figure 8. Configuration for 3270 VTAM terminals

Defining non-VTAM devices

You can use the COMM, LINE, LINEGRP, NAME, and TERMINAL macros to define non-VTAM devices to your IMS system.

If your IMS system uses non-VTAM devices, use the macro statements from the set shown in [Table 10 on page 128](#) to describe your data communication facilities. The number of sets you must prepare depends on the hardware configuration of your IMS system.

All non-VTAM data communication specifications must precede the VTAM macro set in your IMS system definition stage 1 input deck. You receive a stage 1 output warning message if the VTAM macro set is not the last physical set. If an MSC macro set is part of your system definition, it should precede your

VTAM macro set; otherwise, your system definition does not complete. To add VTAM support, you must specify either an ONLINE or ALL system definition on the IMSCtrl macro statement. Non-VTAM data communication macros, the number that is coded, and their purpose are listed in the following table.

Table 10. Non-VTAM data communication macros

Macro	Number of macros coded	Purpose of macro
COMM ¹	One only per IMS system definition	Specifies general communication options that are not associated with any particular terminal type.
LINE	One for each line of the line group following the LINEGRP data	Assigns address and characteristics of one line in a line group.
LINEGRP	One for each line type	Assigns DD names for a group of lines and terminals with like attributes.
NAME	One or more for each logical terminal or component following each TERMINAL macro	Specifies the logical terminal name for the physical terminal that is specified by the TERMINAL macro.
TERMINAL ²	One for each physical terminal attached to the line specified by the LINE statement	Specifies physical terminal characteristics.

Note:

1. You can specify only one COMM macro in an IMS system definition. The COMM macro is required for VTAM.
2. When the TERMINAL statement describes a switched physical terminal, the NAME statement cannot be used to specify logical terminal names for it.

Choosing the IMS master terminal

The IMS master terminal is the key control point for IMS online operations. Choosing a device as the master terminal provides the advantage of convenient data entry and output response.

The IMS master terminal acts as the control point for IMS online operations, data entry, and output response. Keep in mind that you might need a printed copy of many of the responses to commands, as well as a record of the system messages that are sent to the master terminal.

To choose the master terminal, specify MASTER after the logical terminal name on the NAME macro. The NAME macro must follow the TERMINAL macro that describes the terminal chosen.

To choose a secondary master terminal, specify SECONDARY after the logical terminal name on the NAME macro. Logging at the secondary master terminal can be turned on and off using the MSG keyword of the /SMCOPY command.

The /ASSIGN command can be used to switch the secondary master terminal to another destination such as a spool SYSOUT line group.

Choosing master terminal devices

Some restrictions apply for choosing the device for master and secondary terminals, as shown in the table that follows. Your choice for secondary master terminal depends on the expected amount of output and the user's requirement for promptness of printing.

Table 11. Device choices for master terminals

Master terminal type	Choice of device type
Primary	3270 ¹

Table 11. Device choices for master terminals (continued)

Master terminal type	Choice of device type
	SLUTYPE1 (console)
	SLUTYPE2 (console) ²
Secondary	328x ¹
	SLUTYPE1 (first component)
	SPOOL

Notes:

¹ If a 3270 device is specified as the master terminal, a 328x or SPOOL device must be specified as the secondary terminal.

² SLUTYPE2 requires a secondary master terminal. The NAME macro for the secondary terminal must be placed before the primary terminal.

Specifying the master terminal configuration

The following figure shows an example of coding for a master terminal on a 3270 local line.

```
TYPE  UNITYPE=(3270,LOCAL),MODEL=2
TERMINAL  NAME=L3270A
NAME     (VT3270L1,MASTER)
TERMINAL  NAME=L3270B,MODEL=1,OPTIONS=FORCRESP
NAME     VT3270L2
TERMINAL  NAME=L3270C,TYPE=3270-A2,SIZE=(24,80)
NAME     VT3270L3
TERMINAL  NAME=L3270D,TYPE=3270-A3,SIZE=(32,80)
NAME     VT3270L4
TERMINAL  NAME=L3270E,TYPE=3270-A4,SIZE=(43,80)
NAME     VT3270L5
TERMINAL  NAME=L3284A,UNIT=3284,PTRSIZE=132
NAME     (VT3270P3,SECONDARY)
```

The configuration for the master terminal is shown in the figure below:

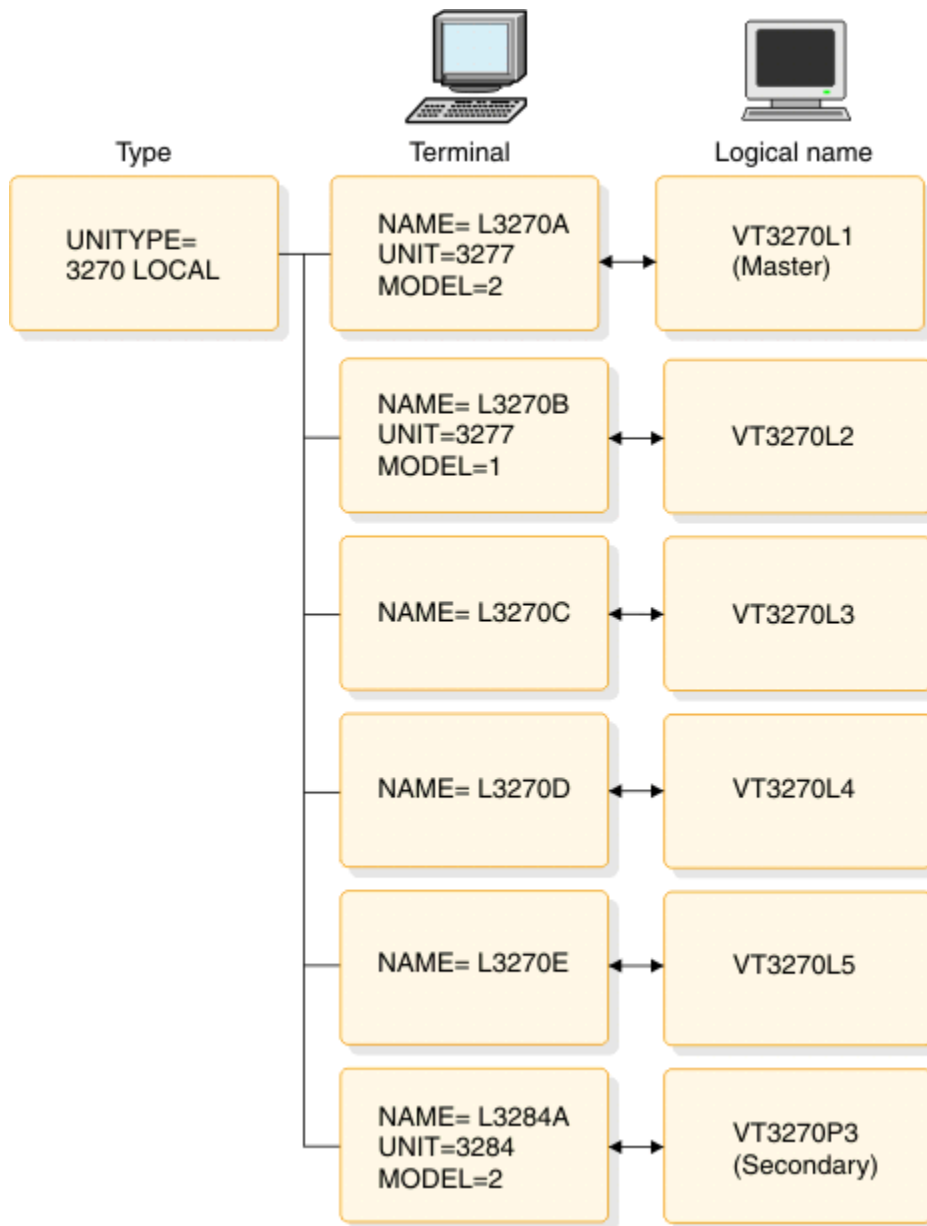

Figure 9. Configuration for a master terminal

Choosing the extent of secondary master logging

To automatically copy the entry and response of key system control commands, use the COPYLOG keyword on the COMM macro. The COPYLOG values that you specify cause all command activity that is issued by any terminal to be copied.

Unless terminals other than the master terminal are likely to issue many commands, specify COPYLOG=ALL. The values of NONE or NOMASTER are not recommended because the printed log of activity provides a valuable audit mechanism. Your choice of automatic copying does not affect the logging of IMS system messages to the secondary master terminal.

Specifying macros for Multiple Systems Coupling

You can use the MSLINK, MSNAME, MSPLINK, and NAME macros to define Multiple Systems Coupling (MSC).

If you plan to use MSC, you must prepare one set of MSC macro statements to describe the additional data communication facilities.

Although Intersystem Communication (ISC) is part of MSC, the macro statements that are used to define ISC are included in the VTAM macro set and not in the MSC macro set.

You must enter the macro sets in the order specified in your IMS system stage 1 system definition input deck. IMS issues stage 1 output warning messages and does not complete system definition if the macro sets are not entered in this order.

When you use MSC in your IMS system, the non-VTAM device macro sets (if used) must precede the MSC macro set in your IMS system definition stage 1 input deck. The VTAM macro set (if used) must occur after the MSC macro set in the stage 1 input deck. The following table lists macros for Multiple Systems Coupling (MSC).

Table 12. MSC data communication macros

Macro	Number of macros coded	Purpose
MSLINK	One for each logical system-to-system link	Defines a logical link to another system.
MSNAME	One for each remote and local system identification	Defines the link name block that relates to the MSLINK statement and the corresponding remote and local system identifications.
MSPLINK	One for each physical link	Defines a physical link to another system in an IMS MSC configuration.
NAME	One or more for each logical terminal that is referenced by your IMS system	Provides the logical terminal name for a physical terminal that is part of the remote system specified in the MSNAME statement.

You can use the UPDATE commands to alter any of the MSC values that have been defined in the macros.

Using multiple IMS systems at the same release level and environment

You can run multiple copies of IMS, with or without multiple systems coupling (MSC), in the same z/OS system and execute them concurrently. However, adding MSC allows communication and sharing of work between IMS systems. If your environment includes multiple IMS systems at the same release level, several considerations related to system definition apply.

When using multiple copies of IMS at the same release level and environment, the following requirements and conditions apply (regardless of the operating system):

- A unique subsystem identifier is required for each IMS DB/DC, DBCTL, or DCCTL control region. Specify this parameter (IMSID) in the IMS procedure for IMS, or in the DBC procedure for DBCTL, and in the dependent address space procedures (IFP, BMP, and MPP) that override the value specified during system definition. The Parm Block member DFSPBxxx can also override the IMSID value specified during system definition. This value must not conflict with any subsystem identifier defined in the system, including other DB or DB/DC systems.
- Type 2 and Type 4 SVCs and the channel-end appendages can be shared.
- When using multiple copies of IMS systems at the same release level in the same z/OS system, you only need one copy of the Type 2 and Type 4 SVCs.
- All suffixed modules must be unique.

Related reading: See the description of the SUFFIX= keyword of the IMSGEN macro in [“IMSGEN macro” on page 437](#).

- DFSVNUCx modules are required to run different IMS control regions.
- You can store unique copies of module DFSVC000, and module DFSVNUCx for each IMS system in a partitioned data set (PDS), concatenated with and in front of IMS.SDFSRESL. Alternatively, you can have

unique copies of DFSVC000 in a PDS as described, and separate other modules within IMS.SDFSRESL through the SUFFIX= parameter of the IMSGEN macro during system definition.

- Under the z/OS authorized program facility, authorize all libraries from which modules are to be loaded for the control region.
- IMS systems can use the same IMS.SDFSRESL data set regardless of the resources that are defined for each system.
- If systems share IMS.SDFSRESL, you can store DFSMDA definitions in separate, authorized PDSs concatenated with IMS.SDFSRESL or use the IMSDALIB feature.
- The following IMS data sets must be unique and separately allocated to each IMS control region:

- IMS.QBLKS
- IMS.SHMSGx
- IMS.LGMSGx
- IMS.IMSMON (IMS Monitor) if used
- IMS.MSDBCP1 if used
- IMS.MSDBCP2 if used
- IMS.MSDBDUMP if used
- IMS.MSDBINIT if used
- IMS.RDS
- Online log data sets (minimum of 3)
- Write-ahead data sets (minimum of 1)

To make these data sets unique for each IMS control region, you can use the NODE= keyword of the IMSGEN macro.

- Each IMS system must have its own terminal network and MSC network (if MSC is included).

Using multiple IMS systems at different release levels

If your environment includes multiple IMS systems at different release levels, several considerations related to system definition apply.

If you are running multiple copies of IMS at different release levels under the same operating system, the operating system must be at a version and release level that is required for the most recent release of IMS.

If you are installing different release levels of IMS in the same z/OS system, remember that running a system using the SVC from a lower-level system is not supported. For example, running an IMS Version 12 system using the SVC from IMS Version 11 is not supported. Similarly, running an IMS Version 12 system using the SVC from IMS Version 10 is not supported.

As of IMS Version 11, IMS uses a dynamic abend dump formatting module (DFSAFMX0). If you are running only versions of IMS that are Version 11 or later, you do not need to install the static abend dump formatting module (DFSAFMD0) on the host z/OS system. If you want to have IMS online dump formatting, and your z/OS system is running any jobs (either online or batch) for IMS Version 10 or earlier, the DFSAFMD0 module must be installed on the z/OS system.

For example, if you are running IMS Version 12 and Version 11, you must install the version of DFSAFMD0 that shipped with either IMS Version 12 or Version 11. For information about installing DFSAFMD0, see *IMS Version 15.4 System Administration*.

Including IMS ETO in the IMS system

IMS Extended Terminal Option (IMS ETO) enables VTAM terminals to log on to IMS TM, regardless of whether they were defined during the system definition process.

IMS TM dynamically builds the required control blocks and queues based on VTAM information and IMS skeleton definitions called descriptors. Without IMS ETO, adding, deleting, or changing terminals that are defined to IMS TM requires that your online system is terminated to incorporate the changes. Additionally,

the stage 1 system definition input can become large if you are defining many terminals. IMS ETO is an optional feature; its installation is verified during IMS TM initialization.

Definitions: Terminals that are defined using system definition are *static* terminals. Terminals not defined through a system definition are *dynamic* terminals.

The IMS ETO feature applies to all VTAM terminals except for MSC VTAM, MTO terminals, and XRF surveillance links. These terminals, and terminals that are supported by non-VTAM access methods, still require an IMS system definition process to introduce changes. The number of terminals that you define dynamically is limited only by your resource constraints.

With IMS ETO, you can:

- Improve system availability by reducing the scheduled down time that is associated with adding or deleting VTAM terminals
- Improve IMS security by relating output message queues (LTERMs) to users rather than to terminals
- Reduce the number of macro statements that are required for static, system-defined VTAM terminals
- Reduce the amount of virtual storage used for IMS ETO terminals and users by allocating storage only when it is required
- Add new terminals and users without terminating and cold starting IMS TM

System definition can build IMS ETO descriptors that support terminals that are currently generated statically, allowing an easy transition to the IMS ETO environment.

Dynamic allocation of VTAM terminals does not require the use of VTAM TYPE, TERMINAL, NAME, VTAMPOOL, or SUBPOOL macros, or the use of MSC remote NAME macros, for the system definition stage 1 input. Instead, you include IMS ETO with the ETOFEAT keyword on the IMSCTRL macro, which causes IMS TM to generate descriptors. IMS TM uses descriptors to build the required control blocks and queues that are associated with terminal definition. With IMS ETO terminals, configuration information from VTAM control blocks is dynamically merged with information from IMS ETO descriptors when a user signs on to IMS TM. Terminal control blocks are not built for IMS ETO terminals until an ACF/VTAM session is established between the terminal and IMS TM, or until a user structure is built. User control blocks are not built until a user signs on to a terminal.

Requirement: Static terminal definition is still required for:

- MTO and secondary master terminals
- MSC physical/logical links
- XRF ISC Surveillance link
- Non-VTAM devices

IMS ETO descriptors are described in [“Enabling IMS ETO for ACF/VTAM terminals”](#) on page 214.

Defining an FDBR region

Fast Database Recovery (FDBR) provides quick access to shared database resources in a sysplex environment that might otherwise be locked by a failed IMS until the failed IMS is restarted.

The FDRMBR= keyword in the DBC and IMS startup procedures identifies the FDBR region to the IMS PROCLIB data set with a two-digit suffix (FDRMBR=xx). The IMS PROCLIB data set member is DFSFDRxx.

The DFSFDRxx member specifies the options used by FDBR. The IMS PROCLIB data set can contain multiple instances of DFSFDRxx, but each DFSFDRxx member in the IMS PROCLIB data set must have a unique, two-digit suffix. FDBR, IMS, or DBC procedures identify which DFSFDRxx member to use.

The FDR procedure executes an FDBR region. The FDR procedure is like those used to define IMS systems (for example, the IMS procedure or the DBC procedure). FDBR is supported in DBCTL and DB/DC environments.

Two parameters, CSAPSB and DLIPSB, in the FDR procedure have a different result than when they are specified for the IMS and DBC procedures. When the FDR procedure specifies CSAPSB and DLIPSB, the

sum of their values defines the PSB pool size. When PSB is also specified, the larger value (PSB or the sum of CSAPSB and DLIPSB) is used.

Both the 64-bit pools and non-resident 31-bit pools in IMS active systems and their associated FDBR and XRF alternate systems must have identical contents. Any parameters and values that you specify on the active IMS system must be the same on the alternate IMS system. For example, the parameters specified in the DFSVSMxx, DFSDfxxx, and DFSPBxxx IMS PROCLIB data set members must be the same, and the sizes of the PSB and DMB pools must be the same.

Related reference

[“DFSFDRxx member of the IMS PROCLIB data set” on page 828](#)

Use the DFSFDRxx member of IMS PROCLIB data set to specify the Fast Database Recovery (FDBR) options used by the FDR.

[“DBC procedure” on page 604](#)

The DBC procedure is an online execution procedure to initialize the DBCTL environment.

[“IMS procedure” on page 639](#)

The IMS procedure is an online execution procedure that initializes the IMS DB/DC environment.

[“Parameter descriptions for IMS procedures” on page 520](#)

All of the parameters that can be specified in startup procedures in the IMS environment are documented in the following subtopics.

[“FDR procedure” on page 634](#)

The FDR procedure executes a Fast Database Recovery (FDBR) address space.

Configuration options for FDBR regions

There can be one FDBR region for each IMS subsystem in the data sharing group. The FDBR region should be on a separate z/OS system from the IMS that it tracks. This is to protect the FDBR region during a z/OS system failure on the system that contains the tracked IMS.

You can configure FDBR in several ways. The following figure shows FDBR regions placed with IMS subsystems. Each FDBR region tracks an IMS subsystem on a different z/OS system. This configuration has the advantage of low resource requirements.

In this configuration, if IMS1 fails, FDBR1 detects the failure and recovers any databases that IMS1 was using when it failed. If z/OS1 fails (with both IMS1 and FDBR4), FDBR1 recovers the database resources for IMS1, and FDBR4 can be established on another system until z/OS1 is restarted.

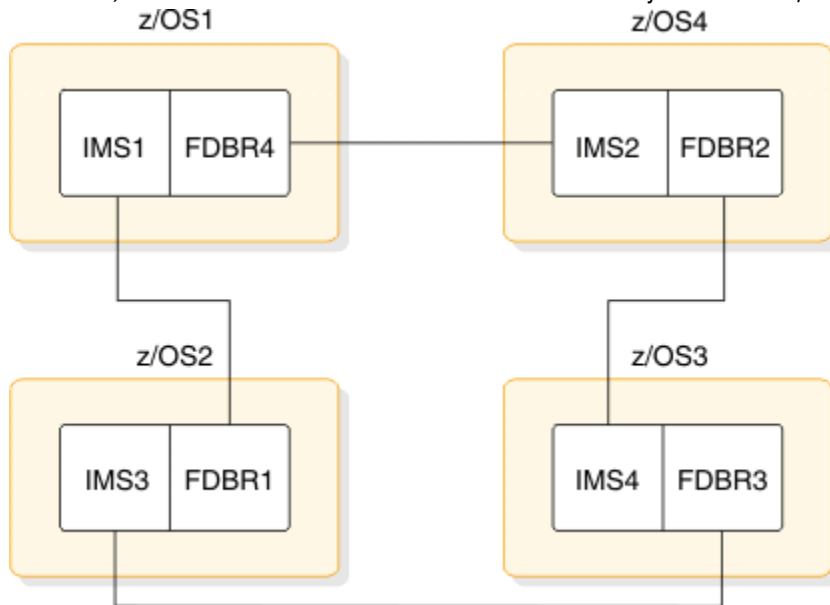

Figure 10. System configuration 1 for FDBR tracking of IMS subsystems

The following figure shows all FDBR regions on a separate z/OS system from the tracked IMS subsystems. This configuration requires an additional hardware resource (the extra z/OS system). If a z/OS system failure occurs on z/OS1, z/OS2, or z/OS3, none of the FDBR regions are affected.

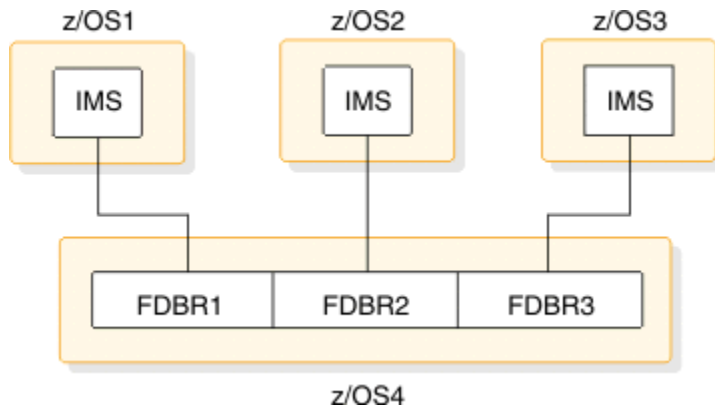

Figure 11. System configuration 2 for FDBR tracking of three IMS subsystems

Enabling an IMS subsystem for FDBR

To reduce the amount of time the sharing subsystems must wait, you can use Fast Database Recovery (FDBR) regions to enable DB/DC and DBCTL subsystems.

About this task

Enabling a DB/DC subsystem for FDBR

To enable a DB/DC subsystem for FDBR, specify the FDRMBR= parameter in the IMS procedure. The FDRMBR= parameter defines the DB/DC system as FDBR-capable.

Note the IMSID of the IMS system that FDBR is to track. Specify this IMSID in the control statement for the DFSFDRxx member of the IMS PROCLIB data set. Match the IMSID to the ID that is specified for the IMSID EXEC parameter.

Restrictions:

- If both FDRMBR= and HSBID= (XRF configuration) parameters are specified in the IMS procedure, the FDRMBR= parameter is ignored.
- For Fast Path systems using FDBR, the Fast Path buffer managers for the tracking system and the active system must be the same: both must be 64-bit or both must be 31-bit. Make sure that the tracking system and the active system have the same value for the FPBP64= parameter of the DFSDFxxx member of the IMS PROCLIB data set.

Enabling a DBCTL subsystem for FDBR

To enable a DBCTL subsystem for FDBR, specify the FDRMBR= parameter in the DBC procedure. The FDRMBR= parameter defines the DBCTL system as FDBR-capable.

Note the IMSID of the IMS system that FDBR is to track. Specify this IMSID in the control statement for the DFSFDRxx member of the IMS PROCLIB data set. Match the IMSID to the ID that is specified for the IMSID EXEC parameter.

Restrictions:

- If both FDRMBR= and DBRSE= (DBCTL standby configuration) parameters are specified in the DBC procedure, the FDRMBR= parameter is ignored.
- For systems using Fast Database Recovery (FDBR), the buffer manager of the tracking system must be the same as the buffer manager of the active system.

Related reference

[“DFSFDRxx member of the IMS PROCLIB data set” on page 828](#)

Use the DFSFDRxx member of IMS PROCLIB data set to specify the Fast Database Recovery (FDBR) options used by the FDR.

[“DBC procedure” on page 604](#)

The DBC procedure is an online execution procedure to initialize the DBCTL environment.

[“IMS procedure” on page 639](#)

The IMS procedure is an online execution procedure that initializes the IMS DB/DC environment.

[“Parameter descriptions for IMS procedures” on page 520](#)

All of the parameters that can be specified in startup procedures in the IMS environment are documented in the following subtopics.

[“FASTPATH section of the DFSDFxxx member” on page 788](#)

The FASTPATH section of the DFSDFxxx member specifies options for Fast Path, such as the use of the Fast Path 64-bit buffer manager. The section must begin with the header <SECTION=FASTPATH>. The FASTPATH section is valid in DB/DC and DBCTL environments.

IMSplex requirements for FDBR

A Fast Database Recovery (FDBR) system must have the appropriate definitions to use the Common Service Layer (CSL), a Structured Call Interface (SCI), or the global online change function.

In an IMSplex with the CSL, you must define the FDBR system with access to CSL. An SCI must be defined on the operating system of the FDBR system.

If you use the global online change function in an IMSplex, any FDBR system that is tracking the active system must also be defined with global online change and it must use the same OLCSTAT data set as the active system. If the IMS system does not use RM services (defined with RMENV=N), the active IMS system must exclusively own the OLCSTAT data set. The OLCSTAT data set can include the IMSID of only the active IMS system.

Specifying enqueue and dequeue requirements

Protecting database integrity when the same database record is concurrently updated requires you to estimate the number of events to be stored (enqueued) and released (dequeued) in internal storage.

The online IMS system protects the integrity of the database when concurrently running programs are updating the same database record. A record of the inter-level update events is maintained for program isolation in tables defined in the control program storage. These are termed enqueue/dequeue tables and consist of 24-byte entries in a z/OS system. As programs reach synchronization points, the entries are freed and the storage can be reused. You need to estimate the number of events that might be recorded for concurrent execution of programs that might process against the same segment type.

The storage is allocated above the 16 MB line.

Specifying security options

Use initialization EXEC parameters to implement general security decisions during system definition. Use the TERMINAL and TRANSACT macros to make resource-specific security decisions.

The security options that you specify must be a part of the overall security design. For a discussion about how to implement security for IMS, including what you need to do to use RACF and security exit routines, see [IMS security \(System Administration\)](#).

You make security choices at various stages of the IMS life cycle. During system definition, use initialization EXEC parameters to implement general security decisions. You can also use the IMSGEN and COMM macros to define security options; however, the values on the initialization EXEC parameters take precedence.

The TERMINAL and TRANSACT macros allow you to make resource-specific security decisions. You can also specify certain general security decisions using keyword parameters such as ISIS, RCF, SGN,

TRN, and others in the startup procedures. You can make other security decisions using the DFSDCxxx members of the IMS PROCLIB data set.

The RCF or ISIS initialization EXEC parameters allow you to specify the security facilities (RACF or exit routines) that you want to use for security checking for dependent regions, transactions, commands, and signon.

To enable or disable support for mixed-case passwords, specify the optional PSWDC=M, R, or U parameter on the DBC, DCC, and IMS procedures. M specifies that IMS supports mixed-case passwords. R, which is the default, specifies that IMS uses whatever is defined for mixed-case passwords in RACF. U specifies that IMS forces all passwords to upper case. See [“Parameter descriptions for IMS procedures”](#) on [page 520](#) for a description of the PSWDC parameter.

Chapter 4. Allocating and cataloging IMS system resources

When installing an IMS DB/DC environment, you must allocate and catalog IMS system libraries and online data sets.

Although this activity is done independently of the actual system definition processing, you need to coordinate this activity with several parts of system definition stage 1 input.

Planning for the definition of IMS data sets requires you to predict the direct access storage to be allocated based on your anticipated application program work load. Some of the data sets you estimate are affected by the design decisions made for system definition. Most of these data sets are automatically generated as DD statements within the members of IMS.PROCLIB.

Note: Certain target and distribution library data sets must be either a PDS or a PDSE. The ADFSJLIB, SDFSJLIB, and ADFSLOAD data sets must be PDSE data sets. SDFSRESL data set must be a PDS. All other target (SDFSxxxx) and distribution (ADFSxxxx) libraries can be either PDS or PDSE.

The External Subsystem Attach Facility (ESAF) supports PDSE load library data sets.

Restriction: IMS supports partitioned data sets extended (PDSEs) for only these libraries: MODBLKS, PGMLIB, SMPLTS, and SDFSJLIB.

IMS system data sets for online change

Planning for the definition of IMS data sets requires you to predict the direct access storage to be allocated based on your anticipated application program work load. Some of the data sets you estimate are affected by the design decisions made for system definition. Most of these data sets are automatically generated as DD statements within the members of IMS.PROCLIB.

Note: Certain target and distribution library data sets must be either a PDS or a PDSE. The ADFSJLIB, SDFSJLIB, and ADFSLOAD data sets must be PDSE data sets. SDFSRESL data set must be a PDS. All other target (SDFSxxxx) and distribution (ADFSxxxx) libraries can be either PDS or PDSE.

Restriction: IMS supports partitioned data sets extended (PDSEs) for only these libraries: MODBLKS, PGMLIB, SMPLTS, and SDFSJLIB.

The External Subsystem Attach Facility (ESAF) supports PDSE load library data sets.

IMS provides the following methods for adding, deleting, and replacing certain resources online without shutting down your IMS system:

- Dynamic resource definition (DRD)
- Online change (OLC)
- When the IMS management of ACBs is enabled, the IMPORT DEFN command for application control blocks (ACBs)

An online change performs changes to a local IMS (called local online change) or to IMS systems in an IMSplex (called global online change). For an overview of performing online changes in these environments, see [The online change function \(System Administration\)](#).

When the IMS management of ACBs is enabled, the online change function is not supported for ACBs and you do not need to allocate ACBLIB data sets. Instead, the ACBs, which represent the databases (DBDs) and program views (PSBs) in the online system, are managed by IMS in the IMS catalog. You activate most ACB changes in an online system by issuing the IMPORT DEFN SOURCE(CATALOG) command. For more information about enabling the IMS management of ACBs, see [IMS management of ACBs \(System Definition\)](#).

Adding, deleting, or changing IMS resources involves changes to the control blocks set up for these resources. If you use online change, making additions, deletions, or changes requires a MODBLKS system

definition. Within a MODBLKS system definition, you specify changes to keyword parameters on the DATABASE, APPLCTN, TRANSACT, and RTCODE macro statements. When designing a DBCTL or DCCTL environment, use the information in this topic as it applies to your system. For a DBCTL environment, no MFS facility exists, and the TRANSACT and RTCODE macros do not apply. A DCCTL environment has no database facilities; therefore, the DATABASE keyword does not apply. A MODBLKS system definition generates the control block members for resources that are to be added or changed online. These control blocks, stored in the IMS.MODBLKS data set, are used by the IMS control region and the MSC Verification utility when an online change to your IMS system is requested.

Before you can use online change, you must create three copies of each of the following libraries:

- IMS.MODBLKS—the library that contains the control blocks to support online change of databases, programs, transactions, and MFS formats
- IMS.ACBLIB—the library that contains database and program descriptors
- IMS.FORMAT—the library that contains your MFS maps produced by the MFS Language and Service utilities

These libraries are for the exclusive use of IMS offline functions and are called the *staging libraries*. Two copies are made of each library, producing data sets with a data set name suffixed with an A and a B, for example, IMS.FORMATA and IMS.FORMATB. These two copies of each library are used by the IMS online system.

Note: If you have multiple copies of the staging IMS.ACBLIB in an IMSplex, each copy of the IMS.ACBLIB must be identical.

When IMS IVP processing completes, the staging libraries and the IMS A libraries are identical, and the A libraries are referred to as the active libraries. IMS draws its execution information from the A libraries. The B libraries, which are not used at this time, are referred to as the inactive libraries.

Figure 12 on page 141 illustrates how libraries are used when you change your system online:

1. You apply changes to the staging libraries.
2. The staging libraries are then copied to the inactive (B) libraries using the Online Change utility.
3. Operator commands are issued to cause the B libraries to become the active libraries; the old active (A) libraries become the inactive libraries.

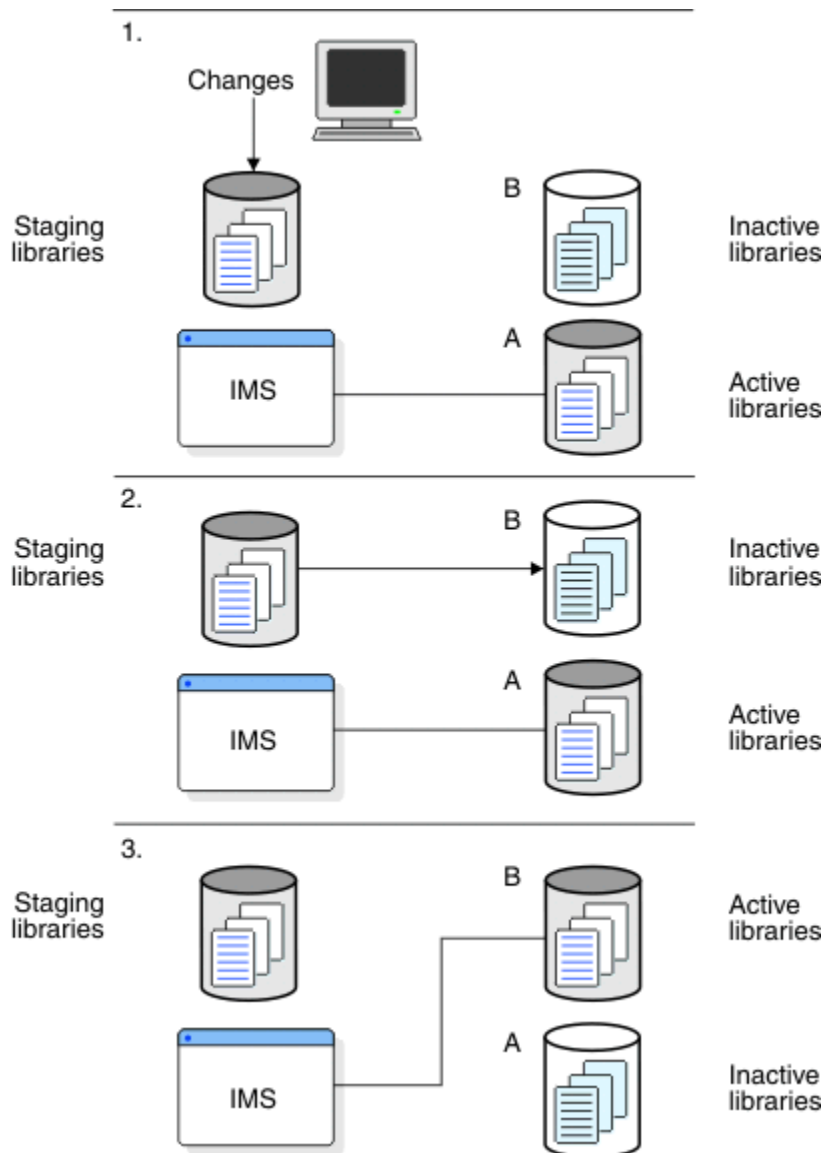

Figure 12. How libraries are used when you change your system online

The process above is repeated as necessary. When you choose to add, replace, or delete any IMS resources, you apply your changes to the offline staging libraries by running either:

- A MODBLKS system definition, if you have added, changed, or deleted application programs, full-function databases, DEDBs, or routing codes
- An ACBGEN, if you have added, changed, or deleted any databases or programs
- The MFS Language and Service utilities, if you have added, changed, or deleted any MFS format definitions

You can apply changes to IMS.FORMAT, IMS.ACBLIB, or IMS.MODBLKS independently or in combination. IMS.MODBLKS is changed by the MODBLKS system definition.

After the sequence of commands (/MODIFY for local online change or INITIATE OLC for global online change) has been issued to cause the previously inactive libraries to become the active libraries, your previously active libraries now become the inactive libraries. They are not destroyed until they are overwritten by the next online change sequence. You can return to the inactive libraries if back up and recovery are necessary, or if an incorrect definition occurs during your online change.

IMS monitors which set of libraries is currently active. If local online change is enabled, this information is kept in a status data set, IMS.MODSTAT. If global online change is enabled, this information is kept in

the IMSPLEX.OLCSTAT data set. All IMS systems in an IMSplex that share the IMSPLEX.OLCSTAT data set must specify the same value on the ACBSHR= parameter, which is specified on both the DFSCGxxx and DFSDFXxxx PROCLIB data set members.

After an online change successfully completes, it persists across all types of IMS restarts. Additionally, the new resources can be easily maintained by running an SMP/E JCLIN against the Stage 1 output stream produced by your MODBLKS system definition to record the contents of the new system definition in your SMP/E control data set. This ensures that any maintenance applied to your IMS system is applied to the currently active IMS system. Do not manage the online change data sets with a migration/recall system that might recall the data set to a volume other than the one to which it was originally allocated. If you do so, IMS might be unable to warm start or emergency start the system.

JES considerations

If you use JES3, include all IMS data sets and databases in the RESDSN statement.

Initializing system data sets when not using online change

If you do not plan to use the online change function, you do not need to maintain the full set of staging, active, and inactive libraries. You need to manage only the staging libraries. You do not need to make copies for the active data sets, which would have the same contents.

About this task

You need to modify the JCL, generated in the IMS member of the IMS PROCLIB data set, for the online execution for the following ddnames:

- MODBLKSA
- MODBLKSB
- IMSACBA
- IMSACBB
- FORMATA
- FORMATB

Procedure

1. For each of these DD statements, use a DSN parameter pointing to a staging library.

For example, ddnames MODBLKSA and MODBLKSB use DSN=IMS.MODBLKS, and ddnames FORMATA and FORMATB use DSN=IMS.FORMAT. If you plan to use terminals in MFSTEST mode, the DD statements for the MFS library that contain the formats under test (ddnames IMSTFMTA and IMSTFMTB) have the staging library (IMS.FORMAT) concatenated to IMS.TFORMAT.

2. Initialize either the IMS.MODSTAT or IMSPLEX.OLCSTAT data set:

- a) If global online change is not enabled, initialize the IMS.MODSTAT data set appropriately, which is most conveniently done using the INITMOD procedure.

This procedure initializes IMS.MODSTAT so that the ddnames with suffix A are set to be the active libraries.

- b) If global online change is enabled, initialize the IMSPLEX.OLCSTAT data set instead of the IMS.MODSTAT data set.

When creating and allocating the OLCSTAT data set, make sure that an End of File (EOF) mark is placed at the beginning of the data set. Failure to do so can produce unpredictable results. To place an EOF mark at the beginning of the data set, use program IEBGENER. Do not use program IEFBR14 to allocate the OLCSTAT data set. IEFBR14 does not place an EOF mark at the start of the data set. An alternate method of allocating the OLCSTAT data set is to use the ALLOCATE function of ISPF utilities. The ALLOCATE function places an EOF mark correctly at the beginning of the data set.

IMS online data sets

An IMS system requires that you define several different types of online data sets. Use the IMS macro statements, including DATABASE and LINEGRP, or IMS execution parameters to define online data sets that meet your business requirements.

The online IMS data sets you need to define are shown in [Table 13 on page 143](#).

Table 13. List of online IMS data sets

ddname	Data Set/Content	Prerequisite
Databases ^{1, 3}	Database data sets	DATABASE macro, ACBLIB content, use of DL/I address space
DFSESL	Optional use for external subsystems	APF library authorization
DFSOLPnn ¹	Online log data set (primary)	Archiving, dynamic allocation
DFSOLSnn ¹	Online log data set (dual)	Archiving, dual logging
DFSTRAnn	External Trace	
DFSWADSn ¹	WADS data set and spares	Dual WADS logging, dynamic allocation
DUMP	Diagnostic storage dump	Installation standards
FORMATA/B ²	From staging Format library	MFSUTL procedure execution, Online Change utility
IEFRDER	IMS.JOBS (PDS)	Use of IMSRDR to start regions
IMSACBA/B ⁴	From staging IMS.ACBLIB	ACBGEN procedure execution, Online Change utility, use of DL/I address space
IMSMON ¹	IMS Monitor output	The IMSMON DD statement in the DBC, DCC, or IMS procedure
IMSRDS	Restart data set	
IMSTFMTA/B ²	Test message formats (PDS)	MFSTEST procedure execution, Online Change utility
LGMSG ²	Long message	Message sizes
MODBLKSA/B	From staging IMS.MODBLKS	Modified for online change
MODSTAT	Active library list	INITMOD procedure, Online Change utility
MSDBCP1 ^{2, 3}	Fast Path MSDB checkpoint	Size of MSDBs
MSDBCP2 ^{2, 3}	Fast Path MSDB checkpoint	Size of MSDBs
MSDBDUMP ^{2, 3}	Fast Path MSDB output	Size of MSDBs and operations
MSDBINIT ^{2, 3}	Fast Path MSDB input	MSDB Maintenance utility
PRINTDD	System output	Installation standards
PROCLIB	IMS.PROCLIB (PDS)	Procedures and initialization, use of DL/I address space
QBLKS ²	Message queue blocks	Transaction traffic
SHMSG ²	Short message	Message sizes
Spool names ²	Spool output (IMS.SYSONnn)	LINEGRP macro

Table 13. List of online IMS data sets (continued)

ddname	Data Set/Content	Prerequisite
STEPLIB	IMS.SDFSRESL (PDS)	APF library authorization

1. This ddname is not required if dynamic allocation macros are coded.
2. This ddname does not apply to DBCTL.
3. This ddname does not apply to DCCTL.
4. This ddname is not required when the IMS management of ACBs is enabled.

Allocating ACBLIB data sets

ACBLIB data sets contain the application control blocks (ACBs), which describe IMS applications, and data management blocks (DMBs), which describe databases and the applications that can access them.

The ACBLIB data sets are required to be allocated only in IMS systems that use ACB libraries. If the IMS management of ACBs is enabled in your IMS system, any instructions to allocate ACBLIB data sets are ignored. The IMS management of ACBs is enabled by the ACBMGMT= parameter in the CATALOG section of the DFSDFxxx PROCLIB member.

You can allocate active and inactive ACBLIB data sets by using either JCL or DFSMDA members.

If you use the DFSMDA member for the allocation of IMSACB, you can dynamically allocate active and inactive ACBLIBs and remove the JCL DD statements for them from their IMS and DL/I procedures.

Do not mix allocation methods. For example, you cannot allocate one ACBLIB data set with JCL and the other with DFSMDA. When the IMS control region is initialized, IMS checks whether any of the ACBLIBs are allocated using JCL. If either IMSACBA or IMSACBB is allocated in the control region or DL/I region using JCL, both must be allocated using JCL. After IMS determines that one of the ACBLIB DD statements is present, no DFSMDA members are processed. If JCL is used for IMSACBA but not for IMSACBB, IMS terminates with abend U0023.

The IMSACBA and IMSACBB DD statements in the JCL for the FDR, DBC, DCC, DLISAS, and IMS procedures take precedence over the DFSMDA member. For dynamic allocation to occur, you would need to remove the IMSACBA and IMSACBB DD statements in the JCL for the FDR, DBC, DCC, DLISAS, and IMS procedures (and keep the DFSMDA member).

Allocating ACBLIB data sets using JCL

If you allocate ACBLIBs using JCL, IMS opens the active ACBLIB when the control region is initialized. The inactive ACBLIB is opened only after an online change procedure is initiated. However, because the JCL DD statement is in the IMS JCL procedure, the inactive ACBLIB data set is always allocated. If you have defined a DL/I SAS, the DD statements for the IMS ACBLIBs are also in the DL/I JCL procedure.

Ensure that the same ACBLIB data sets are specified on the control region JCL and the DL/I region JCL. If an inconsistency occurs in the naming of the ACBLIB data sets specified on the control region JCL and the DL/I region JCL, the IMS control region initialization terminates with abend U0023.

Allocating ACBLIB data sets using DFSMDA

When you use DFSMDA members, the active ACBLIB is allocated when the control region is initialized. The inactive ACBLIB is not allocated until an online change procedure is initiated. However, because the inactive ACBLIB is not allocated during normal IMS processing, you can resize the inactive ACBLIB data sets, add data sets to the concatenation, or change data sets in the concatenation without bringing IMS down.

When you use DFSMDA, the IMS ACBLIB data sets are allocated with disposition of "SHR."

Two DFSMDA members must be defined:

- A DFSMDA member for the data sets in the IMSACBA concatenation.
- A DFSMDA member for the data sets in the IMSACBB concatenation.

The DFSMDA member names correspond to the DD statements for the ACBLIBs. For example, DFSMDA member IMSACBA contains all the data sets in the IMSACBA concatenation. DFSMDA member IMSACBB contains all the data sets in the IMSACBB concatenation.

If you use DFSMDA members and the dynamic allocation of the active ACBLIB fails, IMS terminates with abend U0023.

If DFSMDA members are used to allocate the ACBLIB data sets, and no DFSMDA member is found for the active ACBLIB, the IMS control region initialization terminates with abend U'0071' and message DFS0887A.

Related concepts

[Building the application control blocks \(ACBGEN\) \(Database Administration\)](#)

Related reference

[“DFSMDA macro” on page 417](#)

Use the Dynamic Allocation macro (DFSMDA) to build a member (that is, one or more parameter lists) for naming data sets that can participate in dynamic allocation and deallocation. Members include databases, DEDBs, and data sets.

[“IMS procedure” on page 639](#)

The IMS procedure is an online execution procedure that initializes the IMS DB/DC environment.

[“DLISAS procedure” on page 631](#)

The DLISAS procedure initializes a DL/I separate address space (DLISAS).

[“DBC procedure” on page 604](#)

The DBC procedure is an online execution procedure to initialize the DBCTL environment.

[“DCC procedure” on page 611](#)

The DCC procedure is an online execution procedure to initialize the DCCTL environment.

[“FDR procedure” on page 634](#)

The FDR procedure executes a Fast Database Recovery (FDBR) address space.

[Application Control Blocks Maintenance utility \(DFSUACB0\) \(System Utilities\)](#)

[Database Description \(DBD\) Generation utility \(System Utilities\)](#)

[Program Specification Block \(PSB\) Generation utility \(System Utilities\)](#)

Dynamically allocating the ACB staging library for ACBLIB member online change

Use the DFSMDA member with TYPE=IMSACB to dynamically allocate the ACBLIB staging library for use with ACBLIB member online change.

You can dynamically allocate the ACBLIB staging library using the DFSMDA member TYPE=IMSACB. By using TYPE=IMSACB, you only have to specify the data set name for the staging ACBLIB. A dynamic allocation member with the name of IMSACB is created for the staging ACBLIB.

Restriction: The staging ACBLIB cannot be concatenated.

Restriction: Do not create database MDA members with a DDNAME=IMSACB or with DISP=OLD.

IMS dynamically allocates the staging ACBLIB with DISP=SHR.

To ensure that the staging ACBLIB can be allocated by your IMS control region, you can use either of the following methods:

- Create a DFSMDA member for ACBLIB staging library. For example:

```
DFSMDA TYPE=INITIAL
DFSMDA TYPE=IMSACB,DSNAME=STAGING.LIBRARY
DFSMDA TYPE=FINAL
```

- Add an IMSACB DD statement to your IMS procedure. For example:

```
//IMSACB DD DSN=STAGING.LIBRARY,DISP=SHR
```

If you use the IMSACB DD statement, it takes precedence over the DFSMDA member settings.

Related reference

[“DFSMDA macro” on page 417](#)

Use the Dynamic Allocation macro (DFSMDA) to build a member (that is, one or more parameter lists) for naming data sets that can participate in dynamic allocation and deallocation. Members include databases, DEDBs, and data sets.

[“IMS procedure” on page 639](#)

The IMS procedure is an online execution procedure that initializes the IMS DB/DC environment.

Dynamically allocating the IMSACBA and IMSACBB library data sets

Use the DFSMDA member with TYPE=IMSACBA and TYPE=IMSACBB to dynamically allocate the IMS IMSACBA and IMSACBB library data sets. Using DFSMDA to dynamically allocate IMSACBA and IMSACBB allows you to resize the inactive ACBLIB data sets, add data sets to the concatenation, or change data sets in the concatenation without bringing IMS down.

Restrictions:

- Do not create database MDA members with a DDNAME=IMSACB.
- Dynamic allocation statements for the ACBLIBA and ACBLIBB data sets can be combined in the same job. They cannot be combined with other statements to dynamically allocate any other IMS data set.

IMS dynamically allocates the IMS IMSACBA and IMSACBB library data sets with DISP=SHR.

To ensure that the IMS IMSACBA and IMSACBB library data sets can be dynamically allocated by your IMS control region, perform the following procedure:

- Create DFSMDA members for the IMSACBA and IMSACBB library data sets. The following is a sample of the DFSMDA statements:

```
DFSMDA TYPE=INITIAL
DFSMDA TYPE=IMSACBA
DFSMDA TYPE=DATASET,DSNAME=IMSTESTL.AC B1
DFSMDA TYPE=DATASET,DSNAME=IMSTESTL.AC B2
DFSMDA TYPE=FINAL
END

DFSMDA TYPE=INITIAL
DFSMDA TYPE=IMSACBB
DFSMDA TYPE=DATASET,DSNAME=IMSTESTL.AC B3
DFSMDA TYPE=DATASET,DSNAME=IMSTESTL.AC B4
DFSMDA TYPE=FINAL
END
```

- Remove the IMSACBA and IMSACBB DD statements from your FDR, DBC, DCC, DLISAS, and IMS procedures. Sample JCL of the statements you should remove is shown below:

```
//IMSACBA DD DSN=IMSTESTL.AC B1,DISP=SHR
           DD DSN=IMSTESTL.AC B2,DISP=SHR
//IMSACBB DD DSN=IMSTESTL.AC B3,DISP=SHR
           DD DSN=IMSTESTL.AC B4,DISP=SHR
```

If you left in the IMSACBA and IMSACBB DD statements, they would take precedence over the DFSMDA member, and no dynamic allocation would occur.

Related reference

[“DFSMDA macro” on page 417](#)

Use the Dynamic Allocation macro (DFSMDA) to build a member (that is, one or more parameter lists) for naming data sets that can participate in dynamic allocation and deallocation. Members include databases, DEDBs, and data sets.

[“IMS procedure” on page 639](#)

The IMS procedure is an online execution procedure that initializes the IMS DB/DC environment.

[“DLISAS procedure” on page 631](#)

The DLISAS procedure initializes a DL/I separate address space (DLISAS).

[“DBC procedure” on page 604](#)

The DBC procedure is an online execution procedure to initialize the DBCTL environment.

[“DCC procedure” on page 611](#)

The DCC procedure is an online execution procedure to initialize the DCCTL environment.

[“FDR procedure” on page 634](#)

The FDR procedure executes a Fast Database Recovery (FDBR) address space.

Allocating log data sets

IMS creates logs of activity that are based on online executions. You must allocate sufficient data sets on DASD for the log data associated with your online activity, including online log data sets, system log data sets, and log write-ahead data sets.

For online IMS executions, allocate the IMS log to multiple data sets on DASD. Log records are initially written to an online log data set (OLDS), and then copied (archived) to the system log data set (SLDS). An SLDS can be on DASD or tape. Batch users can allocate a log (also known as the system log data set) to DASD or tape.

A data set containing log records that reflect completed operations not yet written to an online log data set is a write-ahead data set (WADS). For log write-ahead, provide the WADS. You can specify log write-ahead options in the DCLWA keyword of the TRANSACT macro. Log records created by IMS can be written to a WADS before the results of processing are externalized. Thus, a WADS contains a copy of committed log records in the online log data set buffers that have not yet been written to an OLDS.

You do not need DD statements for this log and the system output log (IEFRDER and IEFRDER2) for online IMS executions; you must remove the DD statements from your JCL. With batch, however, the IEFRDER DD statement is required for logging. If you require a secondary log, the ddnames for the primary and secondary log data sets must be IEFRDER and IEFRDER2. The system rounds the BLKSIZE for IEFRDER and IEFRDER2 data sets to a doubleword boundary (a multiple of eight).

Restriction:

- IEFRDER and IEFRDER2 log data sets do not support compression.

You can specify the IMSMON DD statement for both the DB and IMS Monitor data sets. You can allocate the IMSMON data set on DASD or tape (SL or SUL). You need a minimum of two buffers. If the block size you specify is smaller than the system-calculated minimum, the latter is used. The block size is rounded up to a doubleword boundary (a multiple of eight). You can specify the IMSMON data set through a JCL DD statement or a DFSMDA dynamic allocation member. If the block size is dynamically allocated, the default is 4096. If it is JCL allocated and DCB=BLKSIZE=NNNN is not specified in the IMSMON DD statement, the default block size is 1048 even if a larger block size is preallocated.

If you do not specify BLKSIZE, or if BLKSIZE=0 is coded in the JCL, the default for batch log data sets is LRECL=4092 and BLKSIZE=4096.

If you are using a 64-bit capable environment with OLDS blocksize that is a multiple of 4 K, and you allocate a tape device for this IMSMON, it must be a 64-bit capable device. If the tape device is not 64-bit capable, the monitor does not start and you receive the following error message: DFS2201I OPEN ERROR FOR IMSMON.

Recommendation: Use the DFSMS extended format on SMS-managed striped data sets to move the log buffers above the 2 GB boundary, to free ESCA storage for other uses, and to improve logging performance.

Allocating online log data sets (OLDSs)

Three OLDSs are required for online IMS execution. When allocating space for OLDSs, consider how many data sets your system needs, the track size of the storage device, and whether you intend to use dual logging. You can allocate OLDSs as DFSMS extended-format data sets to improve logging performance.

- The maximum number of OLDSs is 100.
- Because the OLDS can be required for restart, it cannot be a temporary data set.

Define the initial set of OLDSs to be acquired by restart initialization in the OLDSDEF control statement in the LOGGER section of the DFSDFxxx member of IMS.PROCLIB. You can dynamically allocate this set of OLDSs, or specify them through DD statements.

- Single or dual online logs can be specified by using the OLDSDEF control statement in the LOGGER section of the DFSDFxxx member of IMS.PROCLIB.
- The only specific naming requirement for an OLDS is that it be unique.

However, ddnames for the OLDS must be of the form DFSOLPnn for primary OLDS, and DFSOLSnn for secondary OLDS, where nn can be any numeric value.

- An OLDS must be a single volume and extent, and at least three data sets must be allocated. However, if an OLDS is to be stopped and started with /STA and /STO commands, DFSMDA members must exist with IMS.SDFSRESL for each such data set. You must provide DFSMDA members for all OLDSs.
- The minimum number of buffers that you can specify is 2, with a maximum of 9,999. Specify the number of OLDS buffers on the OLDSDEF control statement in the LOGGER section of the DFSDFxxx member of PROCLIB data set. The default number of buffers is 5.
- DASD space for each OLDS must be contiguous, and secondary extents are not permitted. Pairs of OLDSs (primary and secondary) must have the same space allocation.

An OLDS can be defined as a DFSMS extended-format, striped data set. Set the data type of the OLDS data class to EXT to define it as an extended-format data set, and the storage class SDR to a value that results in multiple stripes. In JCL allocation, the data class is specified by the DATACLAS parameter and the storage class is specified by the STORCLAS parameter of the DD statement.

Recommendation: Use the DFSMS extended format on SMS-managed striped data sets to move the log buffers above the 2 GB boundary, free ESCA storage for other uses, and improve logging performance.

zHyperWrite can be used for writing to the OLDS to decrease replication latency. To enable or disable zHyperWrite for the OLDS, you have the following options:

- Use the OLDS= keyword in the **ZHYPERWRITE=** parameter in the LOGGER section of the DFSDFxxx PROCLIB member. You must restart IMS to make the change effective. Changes introduced by using this keyword will persist across a restart. For more information, see [LOGGER section of the DFSDFxxx member \(System Definition\)](#).
- Issue the **UPDATE IMS SET(LCLPARM(ZHYPERWRITE(OLDS())))** command. You don't need to restart IMS to make the changes effective. However, changes introduced by issuing this command will not persist across a restart. For more information, see [UPDATE IMS command \(Commands\)](#).

Before enabling zHyperWrite, you must ensure that all the OLDS that will be used by the IMS system are defined as extended format data sets.

You can enable an OLDS to use extended address volumes (EAVs) that are available in z/OS. To enable an OLDS to use EAVs, specify an EAV volume on the VOLSER parameter of the DFSOLPnn DD statement when you allocate the data set. In addition, you can specify the attribute EATTR to indicate whether the data set supports extended attributes.

Restrictions:

- Online log data sets do not support compression.

If you use dual logging, allocate at least six data sets with corresponding numeric values, with a maximum of 200 possible. You can dynamically allocate an additional OLDS using the **/START OLDS** master terminal operator command. If you use dynamic allocation you should preallocate and catalog candidate

data sets, and specify data set names using the dynamic allocation macro, DFSMDA. You must provide a DFSMDA member for each OLDS.

Recommendation: Consider assigning enough OLDS space to each OLDS so that it almost fills an SLDS volume at the end of each archive process. If the size of an OLDS exceeds the capacity of a tape volume, additional tape mounts are required. If the IMS online system is active, the Log Archive utility attempts to access the OLDS while the OLDS is still allocated to the IMS online system. You can use DISP=OLD only if you can allocate sufficient OLDS space to hold all the log records generated by the online system between startup and shutdown. Archiving must then be performed while the online system is not active.

OLDS block sizes must be equal. Predefine the OLDS with block size, logical record length (LRECL), and record format specified at definition time. The OLDS LRECL must equal the OLDS block size minus 4 bytes (LRECL=BLKSIZE-4). The OLDS record format must be variable blocked (VB). The OLDS block size must meet the following requirements:

- It must be a minimum of 6 KB and a multiple of 2048. If IMS is running in z/Architecture® mode, log buffer storage is only fixed above 2 GB if the block size is a multiple of 4096.
- It must not exceed a maximum of 30720 bytes, because this is the largest multiple of 2048 supported by BSAM.
- At a minimum, its length must be the same as the length of the largest log record, plus 78 bytes. The largest log record length is a function of the record size for the long message queue data sets, the EMH terminal buffer size, and the additional overhead of each log record.

The main factor that determines OLDS block size is the track size of the OLDS devices. The OLDS block size cannot exceed the OLDS track size.

The WADS temporarily holds partially filled OLDS buffers, which means that only full OLDS buffers are written to the OLDS. Therefore, choose a large OLDS block size to use DASD space more efficiently.

The following table provides some recommended OLDS block sizes (in multiples of 2048) that maximize DASD space utilization for several DASD devices. [Table 14 on page 149](#) also provides information about blocks per track and bytes of log data per track.

Device type	OLDS block size	Blocks per track	Bytes of log data per track
3380	22,528	2	45,056
3390	26,624	2	53,248
3390	18,432	3	55,296
9340	22,528	2	45,056

The following table provides recommended OLDS block sizes for device types 3380 and 3390 if IMS is running in z/Architecture mode, in which the OLDS block sizes must be multiples of 4096. This table also provides information about blocks per track and bytes of log data per track.

Device type	OLDS block size	Blocks per track	Bytes of log data per track
3380	20,480	2	40,960
3380	12,288	3	36,864
3390	24,576	2	49,152
3390	16,384	3	49,152

Log initialization ensures that the block size specified in the OLDS data set control block (DSCB) data set is large enough to handle the maximum length log record. If the block size is too small, an abend can occur.

To change the OLDS block size, archive all OLDS data, and scratch and reallocate each OLDSs to ensure that all OLDS block sizes remain identical. Also use the DELETE.LOG DBRC command to remove the OLDS from the DBRC RECON data set.

Formatting newly initialized (reinitialized) volumes for an OLDS

Before using a newly initialized or reinitialized volume for an online log data set (OLDS), you must format the volume or space occupied by the OLDS. There are several techniques for formatting the volume or space.



Attention: If a newly initialized (or reinitialized) volume is to contain an OLDS, before it can be used in the online production system, you must format the volume or space occupied by the OLDS. If it is not formatted, or if the block size of the new OLDS is not the same as the existing OLDSs, severe performance degradation and excessive device and channel utilization can be expected until the OLDS is filled once. This problem is noticeable during emergency restart and XRF tracking/takeover.

When formatting the volume or space, the blocks must have the same size as that specified in your OLDS definition. Each block must start with a halfword that is filled with the block size (in hexadecimal), and the remainder of each block must be filled with binary zeros.

Although IMS does not provide a formatting utility, many techniques for formatting are available, such as:

- Copy an existing OLDS (of the same size) into the new OLDS.
- Copy an existing volume into the new volume, rename the OLDS to a new name, and delete unrelated VTOC entries.
- Use another IMS subsystem to fill the OLDS (turn on all traces to the log, and issue checkpoint commands until the OLDS is filled).
- Write your own program to write at least 1 byte of data in each track on the volume, or to fill the OLDS with the maximum number of LRECL blocks.
- Use the z/OS IEBDG utility to format the OLDS.

Related concepts

[z/OS: DFSMSdfp IEBDG test data generator utility](#)

Allocating the write-ahead data set (WADS)

The write-ahead data set (WADS) is a DASD data set containing a copy of log records reflecting committed operations in the OLDS buffers that have not yet been written to the OLDS. WADS space is continually reused after the records it contains are written to the OLDS. The recommended size for your WADS varies by your environment.

You can specify this required data set by JCL, or you can dynamically allocate it. The WADS ddname is DFSWADS n , where n is a number 0 - 9. If you define multiple instances of a WADS, they are used in the WADS DD statement suffix sequence as indicated by the n in the ddname. Preallocate the WADS on DASD supporting Extended Count Key Data (ECKD) architecture and then format the WADS with a /NRE or /ERE FORMAT WA command at least once before it is used. Each WADS must be on the same device type and have the same space allocation.

Recommendation: For increased performance, allocate each WADS on a minimally used device and data path.

Dual WADSs provide an alternative source of input to the OLDS in case an error occurs on one WADS while IMS uses it to close the OLDS. You can use single or dual WADS logging with either single or dual OLDS logging. Specify single or dual WADS logging by using the WADS=S or WADS=D parameter. Define at least two WADSs before enabling dual WADS logging.

You can define up to 10 WADSs to use as spares. IMS automatically switches to a spare WADS if the current WADS becomes unusable after an error occurs. If a write error occurs, logging to the WADS continues if there is at least one WADS is available (for single logging) or two WADSs are available (for dual logging). If you use dual logging, define at least three WADSs so that IMS can activate the spare if a write error occurs. For additional resiliency, define each WADS on a different hardware device.

Define the initial set of WADSs to be acquired by restart initialization in the WADSDEF control statement in the LOGGER section of the DFSDFxxx member of the IMS PROCLIB data set.

The following table shows how many WADS tracks are needed for different OLDS block sizes.

Table 16. OLDS buffers per WADS track

OLDS block size	WADS on 3380	WADS on 3390
6 KB	6.67	8.00
8 KB	5.00	6.00
10 KB	4.00	4.80
12 KB	3.33	4.00
14 KB	2.86	3.43
16 KB	2.50	3.00
18 KB	2.22	2.67
20 KB	2.00	2.40
22 KB	1.82	2.18
24 KB	1.67	2.00
26 KB	1.54	1.85
28 KB	1.43	1.71
30 KB	1.33	1.60

In a non-DASD mirroring environment, set the number IMS WADS cylinders to the number of defined OLDS buffers divided by 20 (rounded up).

In a DASD mirroring environment, set the number of IMS WADS cylinders to at least 300 or the number of defined OLDS buffers divided by 20 (rounded up), whichever is greater. This is done to reduce the rate at which the WADS wraps back to the beginning of the data set.

A larger WADS size does not adversely affect IMS logger performance and can provide more stability during brief increases in logging activity, such as checkpoints, during increases in write response times, such as OLDS switches, and with DASD cache destage issues. However, a larger WADS size affects the time of an emergency restart or a take-over in an extended recovery facility (XRF) environment.

The WADS must be at least five tracks.

You can enable your WADS to use extended address volumes (EAVs) that are available in z/OS V1.12 or later. To enable a WADS to use EAVs, specify an EAV volume on the VOLSER parameter of the DFSWADSnn DD statement when you allocate the data set. In addition, you can specify the attribute EATTR to indicate whether the data set supports extended attributes.

Restriction: Data sets with EATTR=OPT specified cannot be shared with an IMS Version 11 system because IMS Version 11 does not support extended attributes.

The WADS must be defined as a VSAM linear data set with a control interval (CI) size of 4 KB (4096-bytes), secondary space allocation of 0, and the SHAREOPTIONS(3 3) parameter.

The hardware features of High Performance FICON® for z Systems™ (zHPF) and zHyperWrite can be used for writing to the WADS. zHPF increases throughput if it is enabled on the LPAR. zHyperWrite is optionally used to decrease replication latency. You can use one of the following methods to enable or disable zHyperWrite for the WADS:

- Use the WADS= keyword in the **ZHYPERWRITE=** parameter in the LOGGER section of the DFSDFxxx PROCLIB member to enable or disable zHyperWrite. You must restart IMS to make the change effective. Changes introduced by using this keyword will persist across a restart. For more information, see [LOGGER section of the DFSDFxxx member \(System Definition\)](#).
- Issue the **UPDATE IMS SET(LCLPARM(ZHYPERWRITE(WADS())))** command. You don't need to restart IMS to make the changes effective. However, changes introduced by issuing this command will not persist across a restart. For more information, see [UPDATE IMS command \(Commands\)](#).

Sample JCL to allocate WADS as a VSAM linear data set

```
//AMS EXEC PGM=IDCAMS
//SYSPRINT DD SYSOUT=*
//SYSIN DD *

DEFINE CLUSTER -
  (NAME(IMS.A.WADS.VSAM) -
  VOLUME(VOL001) -
  CONTROLINTERVALSIZE(4096) -
  SHAREOPTIONS(3 3) -
  CYLINDERS (20 0) -
  LINEAR)
/*
```

Allocating the system log data set (SLDS)

A system log data set (SLDS) is the single or dual log data set that is created by IMS batch execution on tape or DASD. The SLDS is dynamically allocated to the address space if needed for restart. Define the SLDS (with ddname IMSLOGR) through the dynamic allocation macro DFSMDA.

An SLDS is also one of the output data sets created when the Log Archive utility is used to archive an OLDS. The Log Archive utility can also be used to copy a batch log (SLDS) from DASD to tape (or another DASD data set).

When the Log Archive utility is used to archive an OLDS to tape, you can force the primary and secondary SLDS volumes to contain the same data by specifying the number of log blocks per volume. SLDS block size can be different from the block size of the OLDSs being archived, but the block size of the primary SLDS must be the same as the secondary SLDS block size.

If 3480 tape drives are used for logging, they are forced to run in tape-write-immediate mode.

If SMS-managed generation data sets (GDS) are used for the SLDS, certain error conditions might cause the SLDS to be overwritten. For batch allocations of SMS GDS, the data set is cataloged in deferred roll-in status at step allocation time, and rolled-in at step deallocation time. If a power failure occurs after the SLDS has been written and closed, but before step deallocation, IMS assumes the SLDS is valid; however, SMS does RECLAIM processing at the next allocation. RECLAIM processing means that a data set in deferred roll-in status is reused. For DISP=NEW, the new data would overwrite the existing data.

An SLDS can be defined as an extended-format data set.

Restriction: Data sets with EATTR=OPT specified cannot be shared with an IMS Version 10 or IMS Version 11 system because those IMS versions do not support extended attributes.

Allocating the restart data set

The restart data set contains information that enables IMS to determine from which checkpoint to restart the system.

IMS uses the restart data set during IMS restart to determine from which checkpoint to restart the system. The restart data set is required. A minimum of five tracks must be allocated to the restart data set because it contains the checkpoint-ID table and other control information.

Setting the TOD clock during IPL

The time-of-day (TOD) clock setting is critical to IMS log integrity and the proper functioning of database recovery. Use caution when setting the TOD clock during system IPL to avoid database integrity and recovery problems.

About this task

Attention: Setting the Greenwich mean time (GMT) clock value back at IPL time can cause severe database integrity and recovery problems. Issuing a SET CLOCK command to change the local time, for example at the end of daylight saving time, has no effects on IMS recoverability.

The time-of-day (TOD) clock setting is critical to IMS log integrity and the proper functioning of database recovery, IMS restart, and XRF tracking/takeover. Never set the TOD clock to a time earlier than the immediate prior shutdown or failure without taking actions to reset the recovery base. You can reset the recovery base by invalidating the existing log, image copy, and change accumulation data sets. If the TOD clock must be set to a time earlier than the previous shutdown or failure, you must complete the following procedure to reset the recovery base:

Procedure

1. Reallocate a different block size for the OLDS data sets.
2. Reinitialize the DBRC RECON data set.
3. Make image copies of all database data sets.
4. Cold start IMS.

Results

Issuing a SET CLOCK command does not reset the TOD clock. You can set the TOD clock only at system IPL either by changing the setting of the sysplex timer (external time reference or ETR); or by replying to the IPL prompts for setting the clock with the GMT option. Therefore, you do not need to reset the recovery base if you issue a SET CLOCK command when the TOD setting must be changed for daylight saving time (for example).

Message queue data set allocation in DB/DC and DCCTL environments

The amount of DASD space allocated to the message queue data sets depends on how many transaction codes and logical terminal names you specify during system definition, and how many short and long messages are to be held by the system during any period.

You can change the amount of direct access storage space allocated to the message queue data sets before a cold start of IMS. Reallocation of the message queue data sets with a warm start requires the use of the FORMAT and BUILDQ parameters with either the /NRESTART or /ERESTART command. Allocating less space (than in the previous execution) before an /NRESTART or /ERESTART BUILDQ might cause the restart to abend.

You can allocate up to 10 data sets for the long message queue and 10 data sets for the short message queue. Each data set requires an additional DD statement.

Ensure that all data sets of a given message queue type are the same size. If the data sets have different sizes, the smallest size is used for all. This can reduce the available space of a message queue.

If you change the number of data sets, or if you rename any of the message queue data sets, you must restart the system.

The Queue Manager Concurrent I/O component provides multiple normal short and long message queue data sets. This facility is optional, and you can invoke it by providing 1 - 10 DD cards for the normal short and long message queue data sets.

In order to provide Queue Manager Concurrent I/O:

- IMS initialization allows multiple physical data sets to be viewed as one logical data set.
- You can view both the physical data set and the logical structure.

For single-mode transactions, a message space is available as soon as it is processed by an application program (for example, the program terminates normally or requests the next message).

For multiple-mode transactions, the message spaces are available only after the application program that processes them terminates normally or takes a checkpoint.

For logical terminal messages, a given message space is made available after the successful receipt of this message by the terminal device.

The number of records to be reserved in each data set to allow the system to shut down depends on message throughput and the number of regions scheduled.

Recommendations:

- If you use emergency restart procedures using BLDQ, reallocate logical record size and data set spaces carefully. Allocate enough space to the data set to hold log records relating to message queue activity occurring between checkpoints. The BLDQ procedure always restores the message queue entries to the relative position in the respective queue data sets at the time saved. If the logical record or data set size is decreased, you might be unable to restart in some situations.
- Do not manage the QBLKS, SHMSG, and LGMSG queue data sets with a migration/recall system that might recall the data sets to a volume other than the one to which they were originally allocated. If you do so, IMS might be unable to warm start or emergency start the system.
- Secondary allocation is not allowed for message queue data sets.

The normal short and long message queues allow only one DD card for each.

To prevent message queue overflow due to looping application programs, the Queue Manager and the Queue Space Notification exit routine (DFSQSPC0) monitor the number of buffers assigned to each unit of work (UOW). When a UOW exceeds its buffer limit, the Queue Space Notification exit routine takes action to prevent further inserts by that UOW, and an 'A7' status code is returned to the application program.

Migrating IMS messages to a different release or configuration of IMS

You can use the IBM IMS Queue Control Facility for z/OS (QCF) to migrate messages from one release of IMS to another. QCF is also used after a cold start to migrate messages either to a new configuration or after maintenance.

Monitoring and controlling high message queue users with the IBM IMS Queue Control Facility for z/OS

You can monitor and take action to prevent high message queue users. Use the User Queue Space Notification exit routine (IQMRH0 linked as DFSQMRH0) and the QCF ISPF interface. Using this exit routine helps prevent queue usage from reaching critical thresholds.

Related Reading: For more information about the IBM IMS Queue Control Facility for z/OS, see *IMS Queue Control Facility for z/OS User's Guide*.

Additional restrictions in an XRF environment

Message queue data sets in an XRF environment have two additional restrictions:

- The number of data sets allocated for the short and long message queues must be the same on the primary and the alternate subsystems.
- The names for the message queue data sets must be different on the primary and alternate subsystems. These data sets cannot be shared between subsystems.

Message queue data set secondary allocation

Several factors affect the usage of IMS.QBLKS records. For example, the requirement for multiple temporary destinations when using program isolation can cause an increase in the space requirements. The space requirements for the IMS.QBLKS data set depend on your installation.

The amount of direct access space required for the IMS.SHMSG and IMS.LGMSG data sets is dependent on message throughput. The disk space is reusable as soon as the message to which it was allocated has been processed and it is no longer required for recovery.

Message queue data set space should be allocated in terms of contiguous cylinders for most efficient operation. Secondary allocation is ignored unless the secondary space has been preallocated (that is, multiple volume data set with preallocated space on both volumes). Allocate each message queue data set on a separate direct access device or next to each other, with IMS.QBLKS in the center, on the same direct access device.

Message queue data set allocation restrictions

If emergency restart procedures using BUILDQ are to be used, you must carefully reallocate logical record and data set spaces. The BUILDQ procedure always restores the message queue entries to the relative position in the respective queue data sets they had at the time they were saved. If the logical record or data set size has been decreased, it might be impossible to perform the restart.

Allocating OSAM data sets

To allocate OSAM (overflow sequential access method) single or multiple volumes, use JCL when the data set is loaded using the SPACE parameter.

If your installation control of DASD storage and volumes is such that the OSAM data sets must be reserved ahead of time, or if you decide that a message queue data set requires more than one volume, the OSAM data sets can be preallocated.

Restrictions:

- Do not specify DCB parameters.
- If the data set is to be expanded beyond the preallocate space, a secondary quantity must be specified during preallocation. Queue data sets are constrained to only the space that is preallocated.

If you are preallocating a multiple-volume data set, allocate extents on all volumes to be used. The end of the data set must be correctly indicated in the data set control block (DSCB) on the last volume.

The suggested method is to use the IEFBR14 utility once for each volume on which space is required; do not just use the IEFBR14 utility and specify a DD statement for a multivolume data set. This action only puts an extent on the first volume and does not indicate which volume is the last volume of the data set.

You can allocate OSAM data sets to take advantage of z/OS DFSMS support for large format sequential data sets, which can exceed more than 65 535 tracks per volume. This allows more data to be stored on fewer volumes, helping to minimize sequential data sets that grow large and span many volumes of storage hardware.

To enable support for DFSMS large sequential data sets, specify DSNTYPE=LARGE in the JCL that allocates the OSAM data sets, and bring the data sets online as follows:

- If the new data sets are to be used for an OLDS or a message queue, cold start IMS.

- If the new data sets are to be used for a database, use a database reorganization process (unload and reload) to bring the new data sets online.

You can enable OSAM data sets to use extended address volumes (EAVs) that are available in z/OS V1.12 or later. To enable an OSAM data set to use EAVs, specify an EAV volume on the VOLSER parameter when you allocate the data set. In addition, you can specify the attribute EATTR to indicate whether the data set supports extended attributes.

Restriction: Data sets with EATTR=OPT specified on them cannot be shared with an IMS Version 11 system because that version does not support extended attributes.

“Sample OSAM data set allocation JCL” on page 156 displays the recommended OSAM data set allocation JCL. If you are allocating a large sequential OSAM data set, see “Sample JCL to allocate a large sequential OSAM data set” on page 156.

If the OSAM data sets must be cataloged, use IEHPROGM or Access Method Services (AMS) to ensure that all volumes are included in the catalog entry.



Attention: Do not reuse multivolume OSAM data set extents without scratching and reallocating the space first. Otherwise, an invalid end-of-file mark can be left in the DSCB of the last volume of the data set, which causes an embedded EOF mark somewhere in the middle of the data set.

Sample OSAM data set allocation JCL

```
//OSAMALL JOB
//S1 EXEC PGM=IEFBR14
//EXTENT1 DD DSN=OSAM.SPACE,DISP=(,KEEP),
// UNIT=SYSDA,VOLSER=AAAAAA,
// SPACE=(CYL,(10,5))
//S2 EXEC PGM=IEFBR14
//EXTENT2 DD DSN=OSAM.SPACE,DISP=(,KEEP),
// UNIT=SYSDA,VOLSER=BBBBBB,
// SPACE=(CYL,(15,5))
:
//LAST EXEC PGM=IEFBR14
//EXTENTL DD DSN=OSAM.SPACE,DISP=(,KEEP),
// UNIT=SYSDA,VOLSER=LLLLLL,
// SPACE=(CYL,(15,5))
```

Sample JCL to allocate a large sequential OSAM data set

```
//OSAMALBG JOB
//S1 EXEC PGM=IEFBR14
//EXTENT1 DD VOL=SER=AAAAAA,SPACE=(CYL,(20,5)),UNIT=3390,
// DSN=OSAM.LARGE.SPACE,DISP=(,KEEP),DSNTYPE=LARGE
```

Related tasks

“Defining large sequential data sets” on page 171

Sequential data sets can become large and span many volumes of storage hardware. However, z/OS Data Facilities Storage Management Subsystem (DFSMS) supports more than 65,535 tracks per volume of sequential data sets, which enables more data to be stored on fewer volumes. IMS supports large format data sets.

Allocating VSAM data sets

To define Virtual Storage Access Method (VSAM) data sets, use the z/OS AMS DEFINE CLUSTER command.

VSAM database data sets are defined by an AMS DEFINE CLUSTER command.

Related reading: This command and all its parameters are described in *z/OS DFSMS Access Method Services for Catalogs*.

Sharing of VSAM data sets is specified by the DEFINE CLUSTER SHAREOPTIONS keyword. IMS VSAM databases that use data sharing must be defined with at least SHAREOPTIONS (3,3). This allows IMS to access the VSAM VSI so that any extensions to the VSAM data set are known by all IMS sharing systems.

VSAM data sets opened for update by XRF-capable IMS online systems must also use at least SHAREOPTIONS (3,3), in order for extensions to the VSAM data set to be tracked by the alternate system. Because VSAM data sets opened for input are not extended by VSAM, the VSAM VSI is not required. SHAREOPTIONS (3,3) can be used even if the online system is XRF capable. SHAREOPTIONS (3,3) is not necessary for Fast Path DEDBs; SHAREOPTIONS (2,3) can be used for this environment.

You can enable VSAM data sets to use extended address volumes (EAVs) that are available in z/OS V1.12 or later. To enable a VSAM data set to use EAVs, specify an EAV volume on the VOLSER parameter when you allocate the data set. In addition, you can specify the attribute EATTR to indicate whether the data set supports extended attributes.

Allocating data sets in extended address volumes

IMS supports the allocation of VSAM and non-VSAM data sets in the extended address space (EAS) on the extended address volume (EAV).

The following types of data sets can be allocated in the EAS of an EAV:

- BPE external trace data sets
- OSAM database data sets
- VSAM database data sets
- GSAM data sets, after APAR/PTF PM86782/UK94966 is applied.
- Online log data sets (OLDSs), including large OLDS (for example, greater than 64 KB tracks)
- Write ahead data sets (WADSs)
- Restart data sets (RDSs)
- Message queue blocks data sets
- Long and short message data sets
- Terminal devices with UNITYPE = SPOOL or DISK
- RESLIB data sets (IMS.SDFSRESL)
- MODBLKS data sets for online change (IMS.MODBLKSA and IMS.MODBLKSB)
- Application control block library (ACBLIB) data sets
- DBRC RECON data sets (non-PRA)
- Database Image Copy utility (DFSUDMP0) data sets
- Database Image Copy 2 utility (DFSUDMT0) data sets
- Database Change Accumulation utility (DFSUCUM0) data sets
- Local online change data sets (IMS.MODSTAT)
- Global online change data sets (IMS.OLCSTAT)
- Partitioned data set extended (PDSE) data sets (IMS.MODBLKS, IMS.SDFSJLIB, PGMLIB, SMPLTS, and External Subsystem Attach Facility (ESAF) load libraries)
- Time-controlled operations (TCO) data sets
- System log data sets (SLDSs)
- Recovery log data sets (RLDSs)
- HALDB Indirect List data sets (ILDSs)
- IMS Repository data sets
- MFS map library data sets produced by the MFS Language and Service utilities (IMS.FORMAT)
- IMS Trace facility external trace data sets
- IMS Monitor output data sets

Resource definition data sets

Resource definition data sets (RDDSs) contain resource definitions and resource descriptor definitions, which can be imported from or exported to IMS systems to define a standard set of attributes for resources.

Dynamic resource definition (DRD) uses the resource definition data set (RDDS) to contain the resource definitions and *resource descriptor* definitions (templates that define standard attributes for resources) for a single IMS system. IMS systems can export resources that are either defined by the batch system definition process, or created or updated dynamically, to an RDDS. These resources can then be imported from the RDDS into an IMS system during cold start processing.

The IVP program that builds a sample IMS system includes support for DRD; using the IVP, you can define and allocate two BSAM data sets which can be used as resource definition data sets (RDDSs) to save IMS resource definitions. For information about the IVP sample jobs, see *IMS Version 15.4 Installation*.

The definitions in an RDDS are in a binary format. RDDSs are not supported in IMS FDBR regions.

Recommendation: The RDDS is a BSAM data set that is defined with the RDDSDSN= parameter in the DYNAMIC_RESOURCES section of the DFSDFxxx IMS.PROCLIB member. A minimum of two data sets must be used, but three is recommended. In an IMSplex environment, each IMS in the IMSplex should have its own set of RDDSs.

The data sets are allocated dynamically using DFSRDDDD as the DD name. Each data set contains a header record followed by multiple resource records.

In an XRF environment, the XRF alternate must have its own set of resource definition data sets defined. The XRF alternate processes X'22' log records and applies the changes to its resources. When X'4098' (end checkpoint) log records are processed on the alternate IMS system, the log record is checked to determine whether changes have occurred since the last checkpoint. If so, autoexport is initiated.

DBCTL warm standby systems require their own set of RDDSs if you intend to use AUTOEXPORT or AUTOIMPORT. Because DBCTL warm standby systems are started with an /ERE command, the resource definitions are initially loaded from the log records of a failed IMS active system. The initial checkpoint that is created at the end of restart can initiate an AUTOEXPORT request to export all resource and descriptor definitions in the IMS.MODBLKS data set to an RDDS, which can then be used to recover resources if the DBCTL warm standby system (now the active system) needs to be cold started.

When creating and allocating the RDDS data sets, ensure that an End of File (EOF) mark is placed at the beginning of the data set. Failure to do so can produce unpredictable results. To place an EOF mark at the beginning of the data set, use program IEBGENER. The sample job skeleton DFSRDDAL, which is in the IMS.SDFSSLIB data set, can be used for this step.

The BLKSIZE parameters of the SYSUT1 and SYSUT2 DD statements can be variable. The JCL shown below sets BLKSIZE=32760, which is the maximum size allowable for BSAM data sets. Using the maximum size minimizes the number of I/O requests when importing or exporting to an RDDS and is the recommended value.

The SYSUT1 DD statement should contain the following values:

- RECFM=VB
- BLKSIZE=*value*, where *value* is a number between 4096 and 32 760, inclusive.

The SYSUT2 DD statement should contain the following values:

- The data set name and VOLSER of the RDDS to be created.
- RECFM=VB
- BLKSIZE=*value*, where *value* is the same number that is specified on the SYSUT1 DD statement.
- LRECL=*value*, where *value* is always the BLKSIZE value minus 4.

An alternate method of allocating the RDDS data sets is to use the ALLOCATE function of ISPF utilities. The ALLOCATE function places an EOF mark correctly at the beginning of the data set.

Do not use program IEFBR14 to allocate the RDDS data sets. IEFBR14 does not place an EOF mark at the start of the data set.

Sample JCL for allocating an RDDS is shown below. This sample JCL, which allocates 3 RDDSs, is shipped with IMS as DFSRDDAL in the IMS.SDFSSLIB data set.

```
//ALLO1 EXEC PGM=IEBGENER
//SYSUT1 DD DUMMY, BLKSIZE=32760, RECFM=VB
//SYSUT2 DD DSN=IMSTESTL.RDDS1,
//          DCB=(RECFM=VB, LRECL=32756, BLKSIZE=32760),
//          UNIT=SYSDA, VOL=SER=TSTVOL,
//          DISP=(, CATLG), SPACE=(TRK, (10, 10))
//SYSPRINT DD SYSOUT=*
//SYSIN DD DUMMY
```

As a rule, an RDDS uses 33 percent more space than an IMS.MODBLKS data set that contains an equivalent set of resource definitions.

If you specify a BLKSIZE value other than 32 760, you must also ensure that:

- BLKSIZE is less than or equal to 32 760.
- BLKSIZE is greater than or equal to 4096.
- RECFM=VB.

Recommendation: All RDDS block sizes should have the same value. If the RDDS data sets are defined with different block sizes, a slight performance impact can occur during autoexport processing due to the extra overhead required for reblocking the records.

Related concepts

[“Overview of the IMSRSC repository” on page 37](#)

A repository is a generalized data storage facility that can be used to store any type of information. The IMS resource definition (IMSRSC) repository is a set of VSAM key sequenced data sets (KSDSs) used for storing information. The IMSRSC repository is a repository to store resource (and descriptor) definitions for IMS databases, transactions, programs, and routing codes. This repository is an alternative to the resource definition data set (RDDS) that is used with the dynamic resource definition (DRD) function.

Changing RDDS block sizes

You can change the block size of the RDDS without bringing down IMS.

Before you begin

This procedure assumes that autoexport is enabled to RDDS.

About this task

To change the RDDS block size, complete the following steps:

Procedure

1. Save a copy of the existing system RDDS by using the IEHPROGM utility with the RENAME function. Sample JCL is shown below.

In the JCL, the data sets IMSPLEX1.IMS1.RDDS1, IMSPLEX1.IMS1.RDDS2, and IMSPLEX1.IMS1.RDDS3 on 3390 volumes 111111, 222222, and 333333, respectively, are renamed to SAVE.RDDS1, SAVE.RDDS2, and SAVE.RDDS3, respectively.

```
//RDDNAME JOB .....
//STEP1 EXEC PGM=IEHPROGM
//SYSPRINT DD SYSOUT=A
//DD1 DD VOLSER=111111, UNIT=SYSDA, DISP=OLD
//DD2 DD VOLSER=222222, UNIT=SYSDA, DISP=OLD
//DD3 DD VOLSER=333333, UNIT=SYSDA, DISP=OLD
//SYSIN DD *
RENAME DSN=IMSPLEX1.IMS1.RDDS1, VOL=3390=111111, NEWNAME=SAVE.RDDS1
```



```
RENAME DSNAME=IMSPLEX1. IMS1. RDDS2, VOL=3390=222222, NEWNAME=SAVE. RDDS2
RENAME DSNAME=IMSPLEX1. IMS1. RDDS3, VOL=3390=333333, NEWNAME=SAVE. RDDS3
```

2. Scratch and reallocate all RDDSs with the new block size using either TSO or the IEBGENER job provided in the DFSRDDAL skeleton JCL. The JCL is shipped in the IMS.SDFSSLIB data set.
3. Create a dummy resource descriptor to force an autoexport at the next checkpoint by issuing the command `CREATE PGMDESC NAME(DUMMY) LIKE(DESC(DFSDSPG1))`.
4. Issue the `/CHE` command.
5. Delete the dummy resource by issuing the command `DEL PGMDESC NAME(DUMMY)`.

Results

After autoexport completes, message DFS3371I is issued to the system console, indicating that the autoexport was successful.

If IMS is terminated before autoexport successfully completes, it can be restarted with a warm or emergency restart. Both warm and emergency restarts rebuild the resource and descriptor definitions in the IMS.MODBLKS data set from the IMS log records and automatically export them to a system RDDS at the first system checkpoint.

If a cold start is necessary, perform the following steps:

1. Rename the RDDSs to their original names by using the IEHPRGM, swapping the DSNAME and the NEWNAME data set name values.
2. Bring up IMS and issue the IMS cold start command `/NRE CHKPT 0`.
3. Change the block sizes using the procedure above.

IMSRSC repository and RS catalog repository data sets

The IMSRSC repository uses a set of VSAM key-sequenced data sets (KSDSs) that you define to store the resource and descriptor definitions for the members of an IMSplex in a common repository.

In addition, the Repository Server (RS) has its own repository, called the *RS catalog repository*, that is used to maintain the definitions for the repositories for the IMS repository function. The RS catalog repository manages the association of repository names with repository data sets. An RS address space and the RS catalog repository are required to manage an IMSRSC repository.

You must create two pairs of VSAM KSDSs for each repository and for each RS catalog repository:

- A primary repository index data set (RID) and a primary repository member data set (RMD). The RID stores the names and keys of all members within a repository. The RMD stores the member data indexed by the RID. These data sets are required.
- A secondary RID and a secondary RMD. The secondary RID and RMD provide a duplex copy of the data in the primary RID and RMD. These data sets are required.

Recommendation: In addition to the required data sets, create a third pair of data sets (a spare RID and a spare RMD) to allow data set sparing. The spare RID and RMD are optional. They are empty data sets that are available to replace either the primary or secondary RID/RMD pair if a repository write failure occurs. If a repository write failure occurs on one of the data set pairs, the valid data set pair is copied to the spare and the failed copy is marked as discarded. This strategy reduces the potential for a repository outage because of a data set error condition.

You can create a spare RID and RMD for the IMSRSC repository, but not for the RS catalog repository.

The properties of each secondary and spare data set must be the same as the corresponding primary data set.

The IVP program that builds a sample IMS system includes support for dynamic resource definition (DRD) and the repository. You can use the IVP to define and allocate VSAM KSDSs that can be used as repository data sets. For information about the IVP sample jobs, see *IMS Version 15.4 Installation*.

Guidelines and restrictions for IMSRSC repository and RS catalog repository data sets

Take the following information into consideration when defining the repository data sets:

- The REUSE attribute is required, because it allows the RS to automatically recover corrupt repository data sets at repository open time.
- You can use only share options (1,3) or (2,3). The share options for the INDEX and DATA components of a repository data set must match.
- The SPANNED attribute is not supported. Repository data sets must be non-spanned KSDSs.
- The recommended CI size is 8 KB for both the INDEX and DATA components of all of the repository data sets.
- The RS uses a single local shared resource (LSR) pool with a default 8 KB buffer size. For this buffer pool to be used optimally, make sure that the repository data sets have a matching 8 KB control interval size.

Recommendation: Define the primary, secondary and spare data set pairs on different volumes, to ensure availability. Ensure that the size of the secondary RID and RMD is greater than the size of the primary RID and RMD and that the size of the spare RID and RMD is greater than the size of the secondary RID and RMD.

Related concepts

[“Overview of the IMSRSC repository” on page 37](#)

A repository is a generalized data storage facility that can be used to store any type of information. The IMS resource definition (IMSRSC) repository is a set of VSAM key sequenced data sets (KSDSs) used for storing information. The IMSRSC repository is a repository to store resource (and descriptor) definitions for IMS databases, transactions, programs, and routing codes. This repository is an alternative to the resource definition data set (RDDS) that is used with the dynamic resource definition (DRD) function.

[Sample applications provided by the IVP \(Installation\)](#)

[Starting and stopping the IMSRSC repository \(Operations and Automation\)](#)

[Opening the IMSRSC repository \(Operations and Automation\)](#)

[Recovery in an IMSplex \(System Administration\)](#)

[“Requirements for dynamic resource definition” on page 44](#)

To use dynamic resource definition (DRD), you must define a Common Service Layer (CSL) with at least Structured Call Interface (SCI) and Operations Manager (OM). If the IMSRSC repository is used, a Resource Manager (RM) is required.

Related tasks

[“Enabling dynamic definition for MODBLKS resources with an IMSRSC repository” on page 51](#)

After performing the initial verification of your IMS environment, you can enable dynamic resource definition (DRD) for MODBLKS resources with an IMSRSC repository.

Related reference

[ADD command for FRPBATCH \(System Programming APIs\)](#)

Allocating RS catalog repository data sets

The Repository Server (RS) catalog repository data sets must be allocated before allocating the IMSRSC repository data sets.

About this task

The RS catalog repository provides the link between the repository name and VSAM data sets. Like any other repository, the RS catalog repository consists of 2 pairs of VSAM key-sequenced data sets (KSDSs), a primary pair and a secondary pair of repository index data sets (RIDs) and repository member data sets (RMDs). The RS catalog repository does not support a third or spare data set pair.

The following JCL shows how to allocate the RS catalog repository data sets:

Example

```
//FRPCREATE JOB ,USER,CLASS=A,MSGCLASS=X,NOTIFY=USER
//_ +-----
//_ | SAMPLE JCL TO ALLOCATE REPOSITORY DATA SETS
//_ +-----
//ALLOCATE EXEC PGM=IDCAMS
//SYSPRINT DD SYSOUT=A
//SYSIN DD *
DEFINE CLUSTER(NAME(IMSTESTS.FRP1.CATPRI.RID) -
REUSE -
INDEXED -
KEYS(128 0) -
CYLINDERS(1 1) -
SHAREOPTIONS(2 3) -
FREESPACE(10 10) -
RECORDSIZE(282 282) -
CONTROLINTERVALSIZE(8192) -
VOL(DSHR03) ) -
DATA(NAME(IMSTESTS.FRP1.CATPRI.RID.DATA)) -
INDEX(NAME(IMSTESTS.FRP1.CATPRI.RID.INDEX))

DEFINE CLUSTER(NAME(IMSTESTS.FRP1.CATPRI.RMD) -
REUSE -
INDEXED -
KEYS(12 0) -
CYLINDERS(1 1) -
SHAREOPTIONS(2 3) -
FREESPACE(20 20) -
RECORDSIZE(8185 8185) -
CONTROLINTERVALSIZE(8192) -
VOL(DSHR03) ) -
DATA(NAME(IMSTESTS.FRP1.CATPRI.RMD.DATA)) -
INDEX(NAME(IMSTESTS.FRP1.CATPRI.RMD.INDEX))

DEFINE CLUSTER(NAME(IMSTESTS.FRP1.CATSEC.RID) -
REUSE -
INDEXED -
KEYS(128 0) -
CYLINDERS(1 1) -
SHAREOPTIONS(2 3) -
FREESPACE(10 10) -
RECORDSIZE(282 282) -
CONTROLINTERVALSIZE(8192) -
VOL(DSHR03) ) -
DATA(NAME(IMSTESTS.FRP1.CATSEC.RID.DATA)) -
INDEX(NAME(IMSTESTS.FRP1.CATSEC.RID.INDEX))

DEFINE CLUSTER(NAME(IMSTESTS.FRP1.CATSEC.RMD) -
REUSE -
INDEXED -
KEYS(12 0) -
CYLINDERS(1 1) -
SHAREOPTIONS(2 3) -
FREESPACE(20 20) -
RECORDSIZE(8185 8185) -
CONTROLINTERVALSIZE(8192) -
VOL(DSHR03) ) -
DATA(NAME(IMSTESTS.FRP1.CATSEC.RMD.DATA)) -
INDEX(NAME(IMSTESTS.FRP1.CATSEC.RMD.INDEX))
```

Related concepts

[“Overview of the IMSRSC repository” on page 37](#)

A repository is a generalized data storage facility that can be used to store any type of information. The IMS resource definition (IMSRSC) repository is a set of VSAM key sequenced data sets (KSDSs) used for storing information. The IMSRSC repository is a repository to store resource (and descriptor) definitions for IMS databases, transactions, programs, and routing codes. This repository is an alternative to the resource definition data set (RDDS) that is used with the dynamic resource definition (DRD) function.

[Recovery during the IMSRSC repository data set update process \(Operations and Automation\)](#)

Related reference

[“FRPCFG member of the IMS PROCLIB data set” on page 911](#)

Use the FRPCFG member of the IMS PROCLIB data set to define the Repository Server (RS) configuration parameters relating to performance, communications, and security. FRPCFG also identifies the names of the RS catalog repository data sets.

Allocating the IMSRSC repository data sets

After the Repository Server (RS) address space is started, and before the Resource Manager (RM) is started with the IMSRSC repository enabled, the IMSRSC repository data sets must be created, and the repository must be added to the RS catalog repository.

About this task

The repository information is defined once to the RS catalog repository.

Perform the following steps to allocate the repository data sets:

Procedure

1. Run JCL to create the repository data sets.

The following is an example of the JCL to run:

```
//FRPCREATE JOB ,USER,CLASS=A,MSGCLASS=X,NOTIFY=USER
//_ +-----
//_ | SAMPLE JCL TO ALLOCATE REPOSITORY DATA SETS
//_ +-----
//ALLOCATE EXEC PGM=IDCAMS
//SYSPRINT DD SYSOUT=A
//SYSIN DD *
DEFINE CLUSTER(NAME(IMSTESTS.FRP1.IMSPRI.RID) -
REUSE -
INDEXED -
KEYS(128 0) -
CYLINDERS(1 1) -
SHAREOPTIONS(2 3) -
FREESPACE(10 10) -
RECORDSIZE(282 282) -
CONTROLINTERVALSIZE(8192) -
VOL(DSHR03) ) -
DATA(NAME(IMSTESTS.FRP1.IMSPRI.RID.DATA)) -
INDEX(NAME(IMSTESTS.FRP1.IMSPRI.RID.INDEX))

DEFINE CLUSTER(NAME(IMSTESTS.FRP1.IMSPRI.RMD) -
REUSE -
INDEXED -
KEYS(12 0) -
CYLINDERS(1 1) -
SHAREOPTIONS(2 3) -
FREESPACE(20 20) -
RECORDSIZE(8185 8185) -
CONTROLINTERVALSIZE(8192) -
VOL(DSHR03) ) -
DATA(NAME(IMSTESTS.FRP1.IMSPRI.RMD.DATA)) -
INDEX(NAME(IMSTESTS.FRP1.IMSPRI.RMD.INDEX))

DEFINE CLUSTER(NAME(IMSTESTS.FRP1.IMSSEC.RID) -
REUSE -
INDEXED -
KEYS(128 0) -
CYLINDERS(1 1) -
SHAREOPTIONS(2 3) -
FREESPACE(10 10) -
RECORDSIZE(282 282) -
CONTROLINTERVALSIZE(8192) -
VOL(DSHR03) ) -
DATA(NAME(IMSTESTS.FRP1.IMSSEC.RID.DATA)) -
INDEX(NAME(IMSTESTS.FRP1.IMSSEC.RID.INDEX))

DEFINE CLUSTER(NAME(IMSTESTS.FRP1.IMSSEC.RMD) -
REUSE -
INDEXED -
KEYS(12 0) -
CYLINDERS(1 1) -
SHAREOPTIONS(2 3) -
FREESPACE(20 20) -
```

```

RECORDSIZE(8185 8185) -
CONTROLINTERVALSIZE(8192) -
VOL(DSHR03) ) -
DATA(NAME(IMSTESTS.FRP1.IMSSEC.RMD.DATA)) -
INDEX(NAME(IMSTESTS.FRP1.IMSSEC.RMD.INDEX))

DEFINE CLUSTER(NAME(IMSTESTS.FRP1.IMSSPR.RID) -
REUSE -
INDEXED -
KEYS(128 0) -
CYLINDERS(1 1) -
SHAREOPTIONS(2 3) -
FREESPACE(10 10) -
RECORDSIZE(282 282) -
CONTROLINTERVALSIZE(8192) -
VOL(DSHR03) ) -
DATA(NAME(IMSTESTS.FRP1.IMSSPR.RID.DATA)) -
INDEX(NAME(IMSTESTS.FRP1.IMSSPR.RID.INDEX))

DEFINE CLUSTER(NAME(IMSTESTS.FRP1.IMSSPR.RMD) -
REUSE -
INDEXED -
KEYS(12 0) -
CYLINDERS(1 1) -
SHAREOPTIONS(2 3) -
FREESPACE(20 20) -
RECORDSIZE(8185 8185) -
CONTROLINTERVALSIZE(8192) -
VOL(DSHR03) ) -
DATA(NAME(IMSTESTS.FRP1.IMSSPR.RMD.DATA)) -
INDEX(NAME(IMSTESTS.FRP1.IMSSPR.RMD.INDEX))

```

2. Define the repository to the RS by using the FRPBATCH **ADD** command.

This step enables RM to connect to the repository.

Example

Related concepts

[“Overview of the IMSRSC repository” on page 37](#)

A repository is a generalized data storage facility that can be used to store any type of information. The IMS resource definition (IMSRSC) repository is a set of VSAM key sequenced data sets (KSDSs) used for storing information. The IMSRSC repository is a repository to store resource (and descriptor) definitions for IMS databases, transactions, programs, and routing codes. This repository is an alternative to the resource definition data set (RDDS) that is used with the dynamic resource definition (DRD) function.

Related reference

[ADD command for FRPBATCH \(System Programming APIs\)](#)

[F reposervername,ADMIN \(Commands\)](#)

IMS repository index and member data sets

Each IMS repository definition has room for three pairs of repository data sets, identified as RDS1, RDS2, and RDS3. Each pair consists of a repository index data set (RID) and a repository member data set (RMD).

At least two pairs must be defined. A third, optional, pair can be defined as a spare. The purpose of the spare is to replace either of the active copies in the event of a write failure.

Repository index data sets

Each current member or history member has an RID record. The RID is the data that describes the repository member. It is like the directory data for a PDS member.

The record is a fixed length of 282 bytes with one record per member. Each RID record has a physical key, data, and a record identifier.

The RID also has a single control record, which is used to ensure data integrity.

Repository member data sets

Each current member or history member that has member data has at least one RMD record. This data can be segmented, compressed, or both. It is possible to save a member with no member data. In this case there is an RID record for the member, but no RMD records.

Physically, RMD data set records are variable length. Their minimum size is 12 bytes (the RMD data prefix length), and their maximum size is the size supported by the data sets. The nature of the members saved in the repository determines the average length of the RMD records in a given RMD.

The RMD also has a single control record, which is used to ensure data integrity.

In order to support member data longer than the maximum record size (RECORDSIZE) of the RMD, data segmentation is performed. The segmentation process is not apparent to the user. The member data is always viewed as a contiguous string.

z/OS service CSRCEsrv run length-encoding compression is employed on member data provided that:

- This z/OS service is available.
- The total member data length exceeds 256 bytes.
- Compression proves to be effective.

Related concepts

[“Overview of the IMSRSC repository” on page 37](#)

A repository is a generalized data storage facility that can be used to store any type of information. The IMS resource definition (IMSRSC) repository is a set of VSAM key sequenced data sets (KSDSs) used for storing information. The IMSRSC repository is a repository to store resource (and descriptor) definitions for IMS databases, transactions, programs, and routing codes. This repository is an alternative to the resource definition data set (RDDS) that is used with the dynamic resource definition (DRD) function.

IMS repository data set states

The state of each IMS repository data set is maintained in the Repository Server (RS) catalog repository. This status is recognized at repository open time.

Each repository data set pair can be in one of the following states:

- COPY1 (primary)
- COPY2 (secondary)
- SPARE (empty)
- DISCARD (discarded)
- NONE (not defined)

Because the two active copies are intended to be a duplex pair, the only difference between the COPY1 and COPY2 data set pairs is that COPY1 is the first to be updated during the two-phase update process.

When a repository is created, the RDS1 pair is designated as COPY1 and the RDS2 pair is designated as COPY2. If the RDS3 pair is defined, it is designated as SPARE. However, the status of a repository data set pair is not fixed over time, as shown in the following example activities:

1. A repository is added but RDS3 is not defined:

```
RDS1 Status . . . . : COPY1
RDS2 Status . . . . : COPY2
RDS3 Status . . . . : NONE
```

2. The administrator uses the UPDATE command to define the RDS3 data sets, which are designated as SPARE:

```
RDS1 Status . . . . : COPY1
RDS2 Status . . . . : COPY2
RDS3 Status . . . . : SPARE
```

3. After a write failure occurs with RDS1, the RS discards the RDS1 data sets, and the RDS3 data sets become the new COPY1:

```
RDS1 Status . . . . : DISCARD
RDS2 Status . . . . : COPY2
RDS3 Status . . . . : COPY1
```

4. The administrator uses the DSCHANGE command to change the state of the RDS1 data sets to SPARE:

```
RDS1 Status . . . . : SPARE
RDS2 Status . . . . : COPY2
RDS3 Status . . . . : COPY1
```

A repository data set pair that is identified by the RS as having lost integrity is discarded. If a COPY1 or COPY2 repository data set pair is discarded due to a write error, the repository is stopped at this time to enable recovery. In this event, the RS drives recovery automatically if a SPARE repository data set pair is available. If no SPARE repository data set is available, the repository is stopped, and administrator intervention is required to restart the repository.

Restriction: While a repository is stopped, an administrator can choose to discard a COPY1 or COPY2 repository data set pair. However, the last repository data set with COPY1 or COPY2 status cannot be discarded.

Requirement: Repository data sets intended to be marked SPARE must be empty. If the repository data set pair is not empty, this condition is identified when the repository data sets are opened, and the repository data set pair is discarded.

The data sets associated with a SPARE repository data set pair are allocated to the RS if the repository is open.

The data sets associated with a DISCARD repository data set pair are not allocated to the RS and can therefore be redefined by an administrator. When the data sets have been redefined, the repository data set pair can be changed dynamically (that is, while the user repository is open) from DISCARD to SPARE by issuing the **DSCHANGE FRPBATCH** command or **ADMIN RS** command. In this case, it is allocated and, if it passes validation, assigned the SPARE status.

Two data set pairs can be designated as SPARE temporarily during recovery. This situation can occur, for example, if there a problem occurs with the definition of one of the data sets that the RS is trying to recover to. The recovery process can reestablish the second valid copy when any data set problems are corrected.

Related concepts

[“Overview of the IMSRSC repository” on page 37](#)

A repository is a generalized data storage facility that can be used to store any type of information. The IMS resource definition (IMSRSC) repository is a set of VSAM key sequenced data sets (KSDSs) used for storing information. The IMSRSC repository is a repository to store resource (and descriptor) definitions for IMS databases, transactions, programs, and routing codes. This repository is an alternative to the resource definition data set (RDDS) that is used with the dynamic resource definition (DRD) function.

[Recovery during the IMSRSC repository data set update process \(Operations and Automation\)](#)

Related reference

[F repositervername,ADMIN \(Commands\)](#)

[DSCHANGE command for FRPBATCH \(System Programming APIs\)](#)

Allocating IMS spool data sets

Message processing programs can require their own printed output to be separate from any system-wide SYSOUT (spooled) output. JES2 and JES3 provide SYSOUT data set support. IMS provides for spooled output data sets, as well as a print utility (DFSUPRT0), which can be scheduled during execution of the online system.

IMS spool data sets are on direct access storage devices (DASD). When allocating IMS spool data sets, use the IEBGENER utility to ensure that they are properly initialized (empty).

When allocating IMS spool data sets, code the combination of DISP=(NEW,CATLG) and DSORG=PS on the DD statement.

```
//FORMAT EXEC PGM=IEBGENER
//SYSPRINT DD SYSOUT=*
//SYSUT2 DD DSN=IMS spool data set name,DISP=(,CATLG),
// UNIT=SYSDA,SPACE=space info
//SYSUT1 DD DUMMY
//SYSIN DD DUMMY
```

Allocate space for IMS spool data sets as required, but do not specify secondary allocation. You need DCB parameters DSORG=PS and RECFM=UM. If not supplied, these parameters are set automatically. You can specify block size in the DD statement, but it can be adjusted downward by the system, if larger than the system definition specification.

Records written to this data set are standard z/OS variable-length blocked (VBM) records. The designation of the undefined record format (UM) specification reduces the buffer space requirement in the IMS control region. The minimum block size is 20 bytes, which is sufficient for one print line. The maximum block size is the track size of the device on which the data set is allocated.

Recommendation: Allocate at least two data sets.

IMS uses EXCP to maintain the end-of-file (EOF) mark on the subsequent track of the spool data sets to support online access (TSO browsing).

Restriction: EXCP does not support partitioned data sets extended (PDSEs), extended format data sets, or z/OS UNIX System Services file system data sets.

You can enable a spool SYSOUT data set to use extended address volumes (EAVs) that are available in z/OS V1.12 or later. When allocating a SYSOUT data set on an EAV volume, the data set becomes EAS eligible and can have Format 8 or 9 DSCBs. Having Format 8 or 9 DSCBs implies that the data set can have extents referencing 28-bit cylinder numbers.

To enable a spool SYSOUT data set to use EAVs, specify an EAV volume on the VOLSER parameter when allocating the data set.

Defining spool line groups

You specify, in system definition, a LINEGRP macro to be dedicated to IMS spool output. Associated with the LINEGRP macro are LINE, TERMINAL, and NAME macro specifications. The specification requirements for one such group are illustrated in the following table.

Table 17. Example of IMS spooled data sets in system definition

Macro	Coding	Comments
LINEGRP	DDNAME = (SPOOL1, SPOOL2) UNITYPE = SPOOL	Two IMS spool data sets
LINE	BUFSIZE = 1200	Buffer size in bytes
TERMINAL	AUTOSCH	Optional, specified if automatic scheduling
NAME	RPT10	Use LTERM names that show nature of output

The sample IMS procedure generated by SMP/E processing in IMS.SDFSPROC includes sample DD statements for SPOOL definitions. You must modify these DD statements to reflect the actual SPOOL definitions in your system definition. The ddnames are those given in the LINEGRP macro, and the data set names are of the form IMS.SYSnn. The order of the ddnames in the Stage 1 input stream determines the incremented value of nn. If, in the example shown in the table above, the LINEGRP macro is the first spool line group, the data set name for the ddname SPOOL2 is IMS.SYS02.

The sample DFSWT000 procedure generated by SMP/E processing in IMS.SDFSPROC is intended to be tailored to the print operation for the data sets that are implied in each line group. You must modify this procedure to reflect the actual SPOOL definitions in your system definition. If you define multiple line groups, you can copy this procedure so that each line group has a unique DFSWTnnn procedure. Referring to the same example, a member of the IMS.JOBS data set named IMSWT000 invokes DFSWT000, because it is the first individual job to print output for a spool line group.

The ddnames are those given in the LINEGRP macro, and the data set names are of the form IMS.SYSnn. The order of the ddnames in the Stage 1 input stream determines the incremented value of nn. If, in the example shown in the table above, the LINEGRP macro is the first spool line group, the data set name for the ddname SPOOL2 is IMS.SYS02.

For spool lines, the logical record length (LRECL) specification must be the maximum segment length desired +8, and the block size must be at least equal to LRECL+10. Assign a nonzero value to LRECL. Message segments are truncated at a value of LRECL+4. For example, if the buffer size you specify in the LINE macro is 132, block size can be 116, and LRECL 106. The total size of the data sets must be at least as large as the largest possible message. If the physical block size of the data set is larger than the buffer size specified in the LINE macro during IMS system definition, IMS adjusts the block size (BLKSIZE) downward to the specified BUFSIZE -10.

When all IMS spool data sets defined for a line group are full, IMS shuts down the line and sends a message (DFS998I) to the master terminal that the physical terminal is inoperative. If you specify the AUTOSCH option in the TERMINAL macro during system definition, a spool print program is scheduled as each data set is filled.

UNITYPE = DISK or SPOOL terminals support

Terminals with UNITYPE = DISK or SPOOL support large format data sets that are larger than 65535 track size and are allocated as DSNTYPE=LARGE.

Terminals with UNITYPE = DISK or SPOOL support data sets allocated in the cylinder managed area of extended address volumes (EAV).

Estimating the spooled requirements

To estimate the IMS spooled requirements for your system:

- Determine the LTERM names that the application programs use. There might be output that is unique to a particular program or an agreement among several programs to use the LTERM for their online printed output.
- Obtain estimates of the volume of output so that you can make appropriate space allocations for the DASD data sets.
- Assess the maximum output buffer size to handle the output without unnecessary buildup.
- Obtain some indication of the turnaround requirements for the output and whether the output is to be accumulated or produced in small batches. This information helps you decide how many data sets are needed to support the operation of each group of output (at least two data sets are recommended) and how to schedule the printing operation.

Allocating required IMS.SYSnn data sets

You allocate 1 to 99 DASD data sets with appropriate space specifications. One of the factors that determines the availability of the data set for printing is the size of the primary space. You can either allocate sufficient primary space with any additional output planned to spill to alternative data sets, or you can allocate secondary space for unusual amounts of output.

Allocate and catalog these data sets along with your other online system data sets. The data set names are in the form IMS.SYSnn, beginning with IMS.SYS01.

Implementing spool line groups in an XRF environment

To properly implement spool data sets in an XRF complex, note the following considerations:

- Separate spool data sets must be used for the active and alternate IMS subsystems.
- The appropriate DD statements must be added to the execution procedures for the active and alternate IMS subsystems.
- Separate JOBS data sets must be used for the active and alternate IMS subsystems.
- Separate IMSRDR procedures must be used for the active and alternate IMS subsystems (use the PRDR= execution parameter).
- The IMSRDR procedures used for the active and alternate IMS subsystems must reference the appropriate JOBS data set.
- The IMSWTnnn members of the JOBS data sets must reference the appropriate spool data sets. Depending upon the names chosen for the spool data sets, the SYS2= parameter in the DFSWTnnn procedure can be used to access the correct data sets.

Allocating direct output lines

You can specify record format, logical record length, and block size when you allocate direct output lines.

For direct SYSOUT lines defined to IMS, you can use any valid output device supported by the operating system's BSAM. You can specify the following record formats: F, FM, FB, FBM, FBS, FBSM, V, VM, VB, and VBM. You can specify block sizes, but these are adjusted downward at execution time if they are larger than system-definition maximums.

For fixed-format records, the system-defined buffer size must be at least 20 bytes longer than the DCB block size for the data set. For variable-length records, the buffer size must be 16 bytes longer than the desired block size, including Block Descriptor Word and Record Descriptor Word. To accommodate the data to be written, you can select logical record specifications that are restricted as follows:

- For fixed-format records, the block size must be an even multiple of logical record length.
- For unblocked variable-format records, maximum logical record length equals block size minus 4, and must include the RDW (4 bytes).

Table 18 on page 169 lists device types and the corresponding default data set values for direct output data sets. If you do not supply DCB parameters, these default record format, logical record length, and block size values apply.

Device Type	RECFM	LRECL	BLKSIZE
3211	VM	137	141
2540P	V	84	88 (note 1)
2400 series tape	VBM	125	(note 2)
DASD	VBM	125	1/4 Track

Note:

1. Control characters are not supported.
2. Block size only depends on system-definition buffer size. Each segment is treated as a logical record. When you specify blocking, all segments of a message are contained within a block, unless the block size is not large enough.

Fixed-length segments are padded with trailing blanks. If blocking is used, the balance of the block is also padded when a message does not have the same number of segments as logical records in the block.

Tape blocks are not shorter than 18 bytes, regardless of the record format.

Because volume switching is provided by operator command when tape is used, specify a large value (for example, 99) for the volume count subparameter of the VOLUME keyword on the associated DD statement. In an IMS system in which binary synchronous devices are also operating, and only one tape drive is allocated, timeout problems can occur.

Initializing the RECON data set for DBRC

Before your IMS system can operate, you must initialize the RECON data set, where system log and database status are recorded.

About this task

To prepare for online operation, ensure that the RECON data set, in which system log and database status are recorded, is ready. To initialize the RECON data sets:

Procedure

1. Define two RECON data sets (named RECON1 and RECON2) and a spare data set (named RECON3).
2. Identify the database data sets to be tracked.
3. Record a starting set of data set levels.

Results

Access Method Services parameters define the VSAM KSDS data sets referenced as RECON1, RECON2, and RECON3. Then the INIT.RECON command is used to write the required header record.

Related reading: For more information about the allocation parameters, see *IMS Version 15.4 System Administration*. All three RECON data sets can be dynamically allocated.

A separate record is required for each data set of the databases that are to be controlled. The image copy, reorganization, and recovery operations call upon the current information in the RECON data set records. Using the INIT.DBDS command, you specify:

- The database name, the data set DD name, and the relevant data set names.
- The number and reuse characteristics of image-copy data sets that are to be maintained.
- Indicators of how the data sets are to be allocated by the IMS system.
- The member names of procedures to execute database utilities.

Using other commands in the INIT group creates other records for initial change accumulation, image copy, and system log data set names. For example, use the INIT.DB command to specify the share level for a database and to register a database with DBRC.

For system definition purposes you need to coordinate the entries on DATABASE macro statements, the online JCL requirements, and the database maintenance procedures.

To use IMS 15.4, you must have an IMS 15.4 RECON. Either initialize a new set of RECON data sets, or if you are migrating from an earlier release of IMS, upgrade the RECON data sets to the IMS 15.4 format by using the CHANGE.RECON UPGRADE command.

Important: If you modified IMS Version 10 DBRC skeletal JCL members, you can use them in IMS Version 11 and later. However, DBRC skeletal JCL members supplied with IMS Version 10 and later are not compatible with IMS Version 9 and earlier.

For information about the DBRC-related commands, see *IMS Version 15.4 Commands, Volume 3: IMS Component and z/OS Commands*.

Defining a HALDB indirect list data set

An IMS High Availability Large Database (HALDB) uses indirect pointers rather than direct pointers during reorganization processing. A VSAM KSDS (key sequenced data set) called the indirect list data set (ILDS) stores the indirect pointers. Use the z/OS DEFINE CLUSTER command to define the ILDS.

The use of logical relationships or secondary indexing presents challenges in High Availability Large Database (HALDB) reorganization processing. After a HALDB partition is reorganized, the change in segment locations in the reorganized partition potentially invalidates all the pointers to those segments, whether the pointers are from other database records within the same HALDB partition, other HALDB partitions, or HALDB secondary indexes. In order to eliminate the need to update pointers throughout other database records when a single HALDB partition is reorganized, HALDB introduces the use of indirect pointers.

After a reorganization, direct pointers that have become invalid are updated by using the indirect pointers upon the first reference to the segments that have moved. A new system index data set, which serves as a repository for indirect pointers, is introduced for HALDB. This system index data set is called the Indirect List Data Set (ILDS).

The ILDS is a VSAM KSDS with a 9-byte key. There is one ILDS per partition in a PHDAM, or PHIDAM database. During a reorganization reload or migration reload of segments involved in inter-record pointing, an entry called Indirect List Entry (ILE) is created in the ILDS for each of these segments that is reloaded. Each ILE is 50 bytes in length and contains pointers and control information. The following is a sample of IDCAMS input that is used for defining an ILDS.

```
DEFINE CLUSTER ( -
  NAME (FFDBPRT1.XABCD010.L00001) -
  TRK (2,1) -
  VOL (IMSQAV) -
  FREESPACE (80,10) -
  KEYS (9,0) -
  RECSZ (50,50) -
  REUSE -
  SHAREOPTIONS (3,3) -
  SPEED ) -
  DATA ( -
  CISZ (8192) ) -
  INDEX ( -
  CISZ (2048) )
```

NAME

Defines the HALDB Partition Base Name (FFDBPRT1.XABCD010), ILDS reference (.L), and HALDB Partition ID (00001).

KEYS

A required parameter value. Specifies a key size of 9 bytes at offset 0 into the LRECL.

RECSZ

A required parameter value. Specifies a record size of 50 bytes, the length of an ILE. REUSE must be specified for all HALDB VSAM data sets.

FREESPACE

Provides for free space on initial loads and after CI and CA splits.

To compute the size of an ILDS, multiply the size of an ILE with the total number of physically paired logical children, logical parents of unidirectional relationships, and secondary index target segments.

Defining large sequential data sets

Sequential data sets can become large and span many volumes of storage hardware. However, z/OS Data Facilities Storage Management Subsystem (DFSMS) supports more than 65,535 tracks per volume of

sequential data sets, which enables more data to be stored on fewer volumes. IMS supports large format data sets.

About this task

Sequential data sets are used in IMS primarily for:

- GSAM databases
- Sequential OSAM databases (DSORG=PS - physical sequential)
- Long and short message queues
- Online log data sets (OLDS)
- External trace data sets
- Terminal data sets with UNITYTYPE = DISK or SPOOL

Migration to large format data sets can be done only at data set creation time.

The following process shows one possible approach to defining large sequential data sets:

Procedure

1. Determine which existing GSAM data sets that use the BSAM access method and which sequential OSAM data sets span more than one volume because they are larger than 65,535 tracks.
2. Determine if you have hardware that supports more than 65,535 tracks.
3. Add the DSNTYPE=LARGE parameter to the DD statement in the JCL that defines these data sets.
4. Allocate the new data sets.
5. Bring the new data sets online.
 - If you are using the new data sets for an online data set (OLDS) or a message queue, perform a cold start of IMS to bring the new data sets online.
 - If you are using the new data sets for a database, use a database reorganization process (unload and reload) to bring the new data sets online.

DD statement examples

Here are a few DD statement examples that include the DSNTYPE=LARGE statement that is required to define large format sequential data sets:

DD statement for GSAM data sets

```
//ODASD DD UNIT=SYSDA,VOL=SER=LRGVS1,DISP=(,KEEP),
//      SPACE=(CYL,(4200,5)),DSN=IMSTESTL.GSAM.VARIAB01,
//      DSNTYPE=LARGE,
//      DCB=(LRECL=800,BLKSIZE=80,BUFNO=5,RECFM=FB)
```

DD statement for OSAM data sets

```
//AJOSAMDB DD DSN=IMSTESTL.AJOSAMDB,UNIT=SYSDA,
//           DISP=(NEW,CATLG),DSNTYPE=LARGE,
//           SPACE=(CYL,(4500,100)),VOL=SER=LRGVS1
```

DD statement for OSAM data sets on an extended address volume (EAV)

```
//AJOSAMDB DD DSN=IMSTESTL.AJOSAMDB,UNIT=SYSDA,
//           DISP=(NEW,CATLG),DSNTYPE=LARGE,
//           SPACE=(CYL,(4500,100)),VOL=SER=EAV001,EATTR=OPT
```

Restriction: EAVs are available only in z/OS V1.12 and later.

DD statement to allocate a large spool data set

```
//INIT01 EXEC PGM=IEBGENER
//SYSUT2 DD DSN=IMSTESTL.IMS01.SPOOL1,UNIT=SYSDA,
```

```
//      VOL=SER=DSHR10,SPACE=(TRK,(66000)),DISP=(,CATLG),
//      DCB=(RECFM=VBM,LRECL=137,BLKSIZE=27998),
//      DSNTYPE=LARGE
```

DD statement to allocate a spool data set on an EAV volume

```
//INIT01 EXEC PGM=IEBGENER
//SYSUT2 DD DSN=IMSTESTL.IMS01.SPOOL2,UNIT=SYSDA,
//      VOL=SER=EAV001,SPACE=(CYL,(25)),DISP=(,CATLG),
//      DCB=(RECFM=VBM,LRECL=137,BLKSIZE=27998),
//      EATTR=OPT
```

Related concepts

“Allocating OSAM data sets” on page 155

To allocate OSAM (overflow sequential access method) single or multiple volumes, use JCL when the data set is loaded using the SPACE parameter.

Falling back from large sequential data sets

If necessary, you can fall back from using large sequential data sets.

Procedure

To fall back from using large sequential data sets:

1. Define data sets with less than 65,535 tracks on one volume.
2. Perform a database reorganization process (unload from the large sequential data sets and reload onto multiple volumes) if the large sequential data sets are used for databases.
3. Remove the JCL that defines the large sequential data set or sets.
4. Cold start IMS to bring the multivolume data set or sets online.

Defining Message Formatting Service

Message Formatting Service (MFS) is an editing facility that allows application programs to handle simple logical messages instead of device-dependent data, which simplifies the application development process. These topics describe MFS-related system definition and programming considerations.

The IMS macros that are used to define specifications for MFS are described in the following table.

<i>Table 19. IMS macros that are used to define MFS specifications</i>	
IMS macro	MFS specification
MSGQUEUE	MSGQUEUE is used to specify the maximum size output segment that is properly processed by MFS.
IMSGEN	IMSGEN is used to specify MFSTEST parameters if the COMM macro is not used. The SUFFIX= operand specifies the suffix of the MFS device characteristics table that is generated when TYPE or TERMINAL macros define device symbolic names (that is, TYPE=3270-An) during system definition.

Table 19. IMS macros that are used to define MFS specifications (continued)

IMS macro	MFS specification
COMM	<p>COMM is used to specify the following facilities of MFS:</p> <ul style="list-style-type: none"> • Exits for user-written field and segment editing routines to be included in the generated system • IMS-provided formatting for MFS on the 3270 or SLU 2 master terminal <p>The IMS-provided formatting for the master terminal is provided if OPTIONS=(...,FMTMAST,...) is specified and the 3270 or SLU 2 display used as the master terminal is a 24x80 screen defined as TYPE=(3270,2) or 3270-An with SIZE=(24,80).</p> <p>The name used for the EDITNAME parameter cannot be the same as any MID name.</p>
TYPE	<p>The TYPE, SIZE, FEAT, and OPTIONS keywords can be used in the TYPE and TERMINAL macro. The OPTIONS= operand of the TYPE macro is used to request MFS support for a set of terminal devices described in the subsequent TERMINAL macros. If 3270 or SLU 2 terminals are defined, MFS support is automatic. The TYPE, SIZE, and FEAT keywords define the 3270 and SLU 2 devices using the device symbolic name and generate the MFS device characteristics table containing the device type symbolic name, associated screen size, and physical terminal features. TYPE keywords provide definition for subsequent TERMINAL macros.</p> <p>For NTO, specify UNITYPE=NTO on the TYPE macro.</p>
TERMINAL	<p>The COMPTn= operand can be used to request MFS support for a specific component of a terminal defined as a secondary logical unit. For NTO, specify PU=xx where xx is LUNS, 2741, 2740-1, or TTY.</p> <p>For TYPE UNITYPE=SLUTYPE1</p> <p>COMPTn=(...,MFS-SCS1,...) must be specified for the MFS SCS1 formatting option for the console, printer, or print data set component.</p> <p>COMPTn=(...,MFS-SCS2,...) must be specified for the MFS SCS2 formatting option for the reader, punch, or transmit data set component.</p> <p>For TYPE UNITYPE=SLUTYPEP</p> <p>COMPTn=(...,DPM-An,...) must be specified for the MFS DPM formatting option for the remote controller component.</p> <p>COMPTn=(...,MFS-SCS1,...) must be specified for the MFS SCS1 formatting option for the remote controller component.</p> <p>For TYPE UNITYPE=LUTYPE6</p> <p>COMPTn=(...,DPM-Bn,...) must be specified for MFS ISC formatting.</p>

The following is a sample definition that would allow DPM-An to be used with a remote program. The definition is for a secondary logical unit with two components.

```

TYPE          UNITYPE=SLUTYPEP

TERMINAL     NAME=LUX , OPTIONS=(FORCRESP , ACK , NOBID) ,
              OUTBUF=256 , COMPT1=( PROGRAM2 , DPM - A3 , 7) ,
              COMPT2=( PROGRAM1 , DPM - A4 , 1)

NAME         LTERMQ , COMPT=1

NAME         LTERMY , COMPT=2
    
```

PROGRAM1 is printed output operation; PROGRAM2 is paged output operation.

The OUTBUF= specification would allow RCDCTL to be up to 256 bytes in all format definitions for this secondary logical unit.

The following is a sample definition that would allow DPM-An or SCS1 to be used with a remote program. For this secondary logical unit, the DPM-An definition is for the first two components, and the SCS1 definition is for the third component.

```
TYPE          UNITYPE=SLUTYPEP

TERMINAL      NAME=LUX,OPTIONS=(FORCRESP,ACK,NOBID),
              OUTBUF=256,COMPT1=(PROGRAM2,DPM-A3,7),
              COMPT2=(PROGRAM1,DPM-A4,1),
              COMPT3=(PROGRAM1,MFS-SCS1,IGNORE)

NAME          LTERMQ,COMPT=1

NAME          LTERMY,COMPT=2

NAME          LTERMS,COMPT=3
```

PROGRAM1 is an unprotected operation at the end of a message for paged output or a printer (SCS1) operation; PROGRAM2 is a protected operation at the end of a message for paged output.

The OUTBUF= specification would allow RCDCTL to be up to 256 bytes in all DPM format definitions for this secondary logical unit.

If OUTBUF is not large enough for an entire data page, then more than one VTAM SEND is required to send the page.

Implementing Message Formatting Service

After defining the Message Formatting Service, you can create an index directory to control blocks in the staging library, you can define several format libraries on different physical or logical devices, and you can display the contents of the message format buffer pool counters.

INDEX directory

The INDEX function of the MFS service utility creates an index directory to specified control blocks in the staging library, IMS.FORMAT. The IMS initialization process uses the index directory to construct the MFS dynamic directory in a private storage area. This space is separate from the message format buffer pool.

If a requested control block is not found in the message format buffer pool, MFS looks for an entry in the MFS dynamic directory. If found, the entry gives the relative track address for the indexed control block. This allows MFS to issue a direct read without going through the active format library's PDS directory. If the entry is not found, MFS reads the PDS directory, then reads the requested control block. MFS also creates an entry in the MFS dynamic directory for the control block.

The number of entries in the MFS dynamic directory continually increases until the MTO uses the command **/CHANGE DIRECTORY MFS**. This purges all the entries that were added to the MFS dynamic directory after online initialization.

Error conditions include:

- IMS abending during initialization if storage is unavailable for the MFS dynamic directory
- The **/MODIFY COMMIT** command failing during online change if storage is unavailable for the MFS dynamic directory or the PDS directory index
- No entries being added to the MFS dynamic directory during online operation if storage is unavailable for the MFS dynamic directory. To add entries to the MFS dynamic directory again, issue a **/CHANGE DIRECTORY MFS** command, or restart IMS.

Use of concatenated format libraries

You can define several format libraries on different physical or logical devices, thus permitting faster (concurrent) input/output processing. IMS limits the number of data sets that can be concatenated for

MFS format libraries, IMS.FORMATA, and IMS.FORMATB to 16. All the concatenations must have like attributes.

Phase 2 of the MFS language utility implicitly deletes an old control block from a format library when a new control block with the same name is defined for that library. However, if the new control block is defined for a different library than the one the old copy is in, there is no implicit deletion. Thus, old and new copies for control blocks can exist simultaneously in different format libraries.

One way to prevent this duplication is to explicitly delete duplicate control blocks, using the MFS service utility SCRATCH function. Another way is to add a DD statement in the MFSUTIL phase 2 JCL for each format library (up to 15) that is to have old control blocks deleted when new versions of those control blocks are defined for the staging library, IMS.FORMAT. Phase 2 makes the deletions and updates the index directory \$\$IMSDIR (if there is one) in each library to reflect the new contents.

The new DD statements must have labels of the form, FORMATn, where n is a number from 1 to 15, inclusive. Phase 2 only compresses and adds control blocks to the format library defined with a DD statement labeled FORMAT. (FORMAT is the original staging library.)

At IMS online initialization, the index directories (\$\$IMSDIR) of each of the format libraries are merged into a single MFS dynamic directory for all the format libraries. If a requested control block is not listed in the MFS dynamic directory, MFS reads one PDS directory block from each concatenated library, in sequence, until it finds the control block. This can mean many additional reads if the control block resides on one of the last concatenated libraries.

Pool statistics

Use the **/DISPLAY POOL** command to display the contents of the message format buffer pool counters. The statistics displayed for directory and fetch input/output operations and pool space use should help in determining the appropriate pool size and number of FREs.

Related reading: See *IMS Version 15.4 System Administration* for formulas to calculate the format buffer pool size and the number of FREs.

Chapter 5. Specifying IMS execution parameters

You can specify control region execution parameters in the appropriate control region JCL, or in the IMS, DBC, and DCC members of the IMS PROCLIB data set. Parameters specified in these members override any system definition. The parameters are not positional.

Use the PARM1= and PARM2= parameters on the EXEC statements for the control region to specify the JCL for IMS online execution.

Recommendation: For optimal performance, use the PARM1= and PARM2= parameters rather than creating your own JCL. These parameters are specified symbolically for the control region.

System control and performance EXEC parameters for the IMS control region

Using IMS EXEC parameters, you can control many IMS system resources such as number of active regions, performance options, z/OS options, DLISAS options, dump formatting options, IRLM options, Fast Path settings, subsystem options, and storage pool definitions.

This topic describes the EXEC parameters that can be used to control IMS system resources.

Identifying the nucleus

The SUF parameter is generated as a null value for the IMS procedure, indicating that the default nucleus name has a one-character suffix of 0. If you are using an alternative control program, you must specify this parameter.

Overriding the number of active regions

Use the PST parameter to override the expected number of regions that are to be in operation during the online execution. Additional regions can be dynamically allocated, up to the maximum allowable number permitted by your operating system. If you do not specify the PST parameter, the default number of regions is the number specified for the MAXREGN keyword in the IMSCTRL macro.

Specifying performance options

Three parameters contribute to general performance strategy. The FIX= parameter specifies a two-character suffix for the member DFSFIXxx in the IMS PROCLIB data set. This suffix indicates which member should describe all modules and control blocks that are to be page fixed. The EXVR= parameter allows you to page-fix buffers used for the management of message queues. The parameter is generated with a null value; you must specify EXVR=1 to indicate the page-fixing action. Similarly, the PRLD= parameter specifies a two-character suffix for the member DFSMPLxx, where all preloaded modules are listed.

Specifying z/OS options

Several parameters apply only to the z/OS operating system. The SRCH parameter allows you to take advantage of any special library structure to optimize the search for loaded modules. You can override the default value of 0 with a value of 1 if you want the JPA and LPA to be searched before IMS program libraries.

To reduce the amount of z/OS CSA (common storage area) that IMS uses you can use one of the following techniques:

One technique is to specify LSO=Y on the IMS procedure to cause some control blocks and some IMS modules that are used for DL/I processing to be loaded into the control program's private storage. To allow for this transfer, use the following sum to increase the size of the control region:

```
220K + OSAM buffer pool + VSAM buffers + enqueue/dequeue tables
```

Specifying DL/I separate address space options

An additional variation of the local storage option is to use the DL/I separate address space. You do this by specifying LSO=S. This address space contains most of the DL/I code, control blocks, and database buffers for full-function databases. Again, z/OS cross memory services are used.

Specifying dump formatting options

In a DC environment, you can request the following types of dump outputs for errors that terminate IMS: SDUMP, SYSMDUMP, SYSABEND, or SYSUDUMP. To do this, specify the FMTO startup parameter in combination with z/OS dump DD statements.

For SYSMDUMP, you should provide operational procedures for saving and formatting dumps; otherwise, you can overlay a SYSMDUMP if you must restart IMS before the previous SYSMDUMP is transferred.

You can also request dump outputs for some errors that do not terminate IMS. Your choice of dump depends on several factors: the type of failure, the FMTO parameter option, and the IMS spin-off and z/OS dump DD statements that have been selected. For more information about the FMTO parameter and about using dumps in these situations, see *IMS Version 15.4 System Utilities*.

Specifying IRLM options

If an execution of the IMS online system is to use IRLM as lock manager or participate in block-level sharing, specify IRLM=YES. Specify the z/OS subsystem name for the IRLM associated with this control region on the IRLMNM parameter.

You cannot use the UHASH parameter with the IRLM to specify the name of an alternative Fast Path hashing module. The UHASH parameter is ignored, and DBFLHSH0 is always used as the hashing module.

Enabling Fast Path

Use FP= to enable or disable Fast Path.

The FPCTRL macro, although allowed for compatibility, is ignored by system definition. Fast Path is enabled by setting FP=Y in the DFSPBxxx member of the IMS PROCLIB data set or by specifying FP=Y as a startup parameter. The default is FP=N, so you must explicitly specify FP=Y to enable Fast Path.

If you specify FP=N and you attempt to use a Fast Path resource or command, results are unpredictable.

To override the initial value coded on DFSPBxxx, use the FP= parameter at execution time.

Specifying subsystem identification parameters

Use the SSM parameter to reference a member in the IMS PROCLIB data set which identifies the Db2 for z/OS or IBM MQ subsystems that can be accessed from application programs executing in dependent regions. The one- to four-character suffix that you specify, together with the currently assigned name for IMSID, forms the member name. The member contains entries, each identifying a Db2 for z/OS or IBM MQ subsystem (by its z/OS subsystem name). All subsystems to be accessed from programs executing in dependent regions must be identified by an entry.

Depending on its entry, a region can access all, some, or none of these subsystems. To allow a dependent region to access all subsystems identified to the IMS control region, do not specify the SSM parameter for the dependent region or have the SSM entry specify the same member as the IMS procedure. To allow a dependent region to access only selected Db2 for z/OS or IBM MQ subsystems, specify an SSM parameter on the dependent region procedure that points to a member containing only those specific subsystems.

To prevent a dependent region from having access to any subsystem identified to the IMS control region, specify a member containing no entries.

See *IMS Version 15.4 System Administration* for details about how to specify the individual entries and construct the member of the IMS PROCLIB data set.

Modifying storage pool definitions for the storage manager

You can set an upper expansion limit for the AOIP, HIOP, CIOP, CMDP, SPAP, DYNP, LUMP, LUMC, FPWP, and EMHB storage manager pools by using the appropriate parameters at execution time. IMS establishes these storage pool definitions without an upper expansion limit, because they are dynamic storage pools that expand and contract as needed during execution.

Use caution in specifying upper expansion limits. If an upper limit is too low, IMS might abend. Under normal circumstances, a pool should never reach its upper limit. The intent of the upper limit is to keep pools from consuming so much storage that an out-of-storage condition occurs.

Use the SPM=nn parameter to specify the suffix for DFSPMnn. DFSPMnn identifies the member of the IMS PROCLIB data set that overrides the storage pool definitions established by IMS.

Dynamic resource definition EXEC parameters

You can use the DFSDF= EXEC parameter to override dynamic resource definition (DRD) values that were specified on the DFSDFxxx member of the IMS PROCLIB data set.

Use DFSDF= to identify the DRD PROCLIB member.

By using DFSDF= as an EXEC parameter in the control region, you can override the suffix for DFSDFxxx that was provided during system definition.

Database and PSB exec parameters for the control region

The IMS procedure includes parameters that enable you to control database buffer requirements, override predefined buffer sizes, and manage performance.

Three kinds of parameters in the IMS procedure that are related to database and PSB processing are:

- Pointers to database buffer requirements
- Overrides of predefined buffer sizes
- Performance options

Database buffer requirements

You can use the VSPEC parameter of the IMS procedure to predefine buffer pool requirements for databases that use the OSAM or VSAM access method.

Use the VSPEC parameter to specify a two-character suffix for member DFSVSMxx in the IMS PROCLIB data set. This member predefines the buffer pool requirements for databases that use OSAM or VSAM as the access method. The IMS procedure generates a default value of 00 that points to a general-purpose buffer definition in member, but you can change this suffix.

See [“IMS buffer pools” on page 206](#) to specify subpool sizes.

Buffer sizes for databases that use OSAM or VSAM

Performance studies often indicate a need to increase DMB or PSB buffer space. You can override the system definition values to implement this change.

Several parameters enable you to redefine the size of buffer pools that hold DMBs and PSBs. Specify a value that represents the size as a number of 1024-byte blocks. For example, a value of 18 represents the size as 18432 bytes (18 x 1024 = 18432). IMS then rounds up this number based on the nearest whole number of pages on which these bytes fit. For example, if one page in z/OS equals 4096 bytes, the

value of 18 blocks would result in the allocation of 20480 bytes. This value overrides the value defined in system definition. The calculation is as follows:

Formula

```
18 x 24 = 18432/4096 = 4.5 pages (round up to 5)
5 x 4096 = 20480 bytes
```

If you use the DL/I address space option, two PSB pools exist: one in the z/OS common area and one in the DL/I address space. Use the CSAPSB and DLIPSB parameters on the IMS procedure to specify the size of the PSB pools. If the DL/I address space is not used, specify the size of the single PSB pool using the PSB= parameter on the IMS procedure.

If Fast Path resources are used, an EPCB pool must contain extensions to Fast Path PCBs. For each PCB referencing a DEDB or MSDB database, an EPCB is required. This pool is used only by MPP regions, not by IFP or BMP regions.

Use the parameters of the IMS procedure in the following list to specify buffer pool sizes:

- DMB
- PSB
- PSBW
- CSAPSB
- DLIPSB
- EPCB

The IMS procedure is generated with null value parameters for these storage areas.

Performance options for data management and program specification blocks

You can override the system definition specifications for individual database DMBs and PSBs using the RES parameter on the IMS procedure.

System definition lets you specify individual database DMBs and PSBs to be resident with the DATABASE and APPLCTN macros, respectively. You can override this specification with the RES parameter. The IMS procedure generates this as a null parameter; the default is RES=Y.

Request that all the control blocks are not to be made resident by specifying RES=N. You might do this when executing a test system or if storage is temporarily constrained.

Data communication EXEC parameters for the control region

Using EXEC parameters, you can override definitions for data communication that were initially set during IMS system definition.

Three kinds of parameters in the IMS procedure are related to data communication:

- Overrides of predefined buffer sizes
- Overrides and options particular to Message Format Service (MFS)
- Performance options

Buffer sizes for data communications

By monitoring communication traffic you might decide to increase buffer space. Use the parameters of the IMS procedure shown below to allocate virtual storage and override the buffer pool sizes predefined in system definition.

Table 20. Overriding buffer pool sizes with data communication parameters

IMS procedure parameter	System definition specification	
	Macro	Parameter
FBP ¹	BUFPOOLS	FORMAT(size1)
QBUF ²	MSGQUEUE	BUFFERS
RECA	COMM	RECANY

¹ Specify a value representing the number of 1024-byte blocks.

² By increasing the number of buffers (used for the message queue data sets), you can reduce the frequency of I/Os.

Overrides of predefined parameters

Monitoring communication traffic often results in a decision to increase buffer space or the number of buffers. The following execution parameters are provided to override the size and number of some of the buffer pools predefined at system definition:

FBP

Overrides the size specified on the FORMAT(size1) keyword of the BUFPOOLS macro.

QBUF

Message queue buffer. Adjusts the size of the message queue buffer pool. QBUF enables you to override the number of blocks to hold messages in the control program's storage. By increasing the number of buffers used for the message queue data sets, you can reduce the frequency of I/Os. The default number of buffers is specified in the MSGQUEUE macro.

EMHL

Specifies the EMH buffer length for Fast Path transactions.

RECA SZ

Specifies the size of the Receive Any buffer.

RECA

Overrides the number of Receive Any buffers predefined in system definition by the RECANY keyword of the COMM macro.

SAV

Specifies the allowed maximum number of concurrently active device I/Os.

ETO parameters

Use the following parameters to define ETO options:

ALOT

Specifies the amount of time allotted before a terminal in session is automatically logged off if no user successfully signs on.

ASOT

Specifies the amount of time allotted before a signed-on user is automatically signed off if no input or output activity occurs.

LHTS

Specifies the number of slots for the CNT/LNB/RCNT hash table.

NHTS

Specifies the number of slots for the VTCTB hash table.

UHTS

Specifies the number of slots for the SPQB hash table.

DLQT

Specifies the number of days allotted before a queue containing data that has not been allocated is classified as a potential dead-letter queue.

ETO

Specifies whether terminals and queues that are not defined to IMS are to be supported.

DSCT

Specifies the suffix of the descriptor member DFSDSCTy.

Performance options

Use the following parameters to define performance options:

VAUT

Specifies the use of VTAM-Authorized Path.

NLXB

Specifies that parallel sessions are added during system startup.

FESTIM

Overrides the timeout value for Front End Switching; this value is predefined during system definition.

MFS options

When you use MFS, you can adjust the capacity of the system by adjusting the availability of format blocks. Use the FRE parameter to specify the maximum number of active blocks in the message format buffer pool. You need to coordinate this number with the value specified for the FBP pool size parameter.

Performance options for VTAM systems

The VAUT parameter offers a performance option to systems using VTAM. You can override the null value generated in the IMS procedure and specify the use of VTAM Authorized Path.

The NLXB parameter allows you to add parallel sessions during system startup. The number you specify is added to the number defined in the SESSION keyword in the definition of the MSC physical link (MSPLINK).

The FESTIM parameter overrides the timeout value for front-end switching that is predefined in system definition. You specify the parameter on the COMM macro with a value from 1 second to 300 seconds.

Fast Path EXEC parameters in DCCTL or DB/DC

Use Fast Path EXEC parameters to specify database buffer sizes and specify DEDB options in a DCCTL or IMS DB/DC environment.

Note: Although the DCCTL environment does not support Fast Path databases, it does support Fast Path processing and transactions.

The PARM1= and PARM2= positional parameters for the control region's EXEC statement that can be used to specify the Fast Path parameters are shown below.

Table 21. Categories and purpose of Fast Path control region parameters for DCCTL and DB/DC

Category	Parameter	Purpose
MSDB load	MSDB	Specify the DBFMSDBx suffix
Database buffer sizes	BSIZ	Specify the common size of a buffer
	DBBF	Specify the maximum number of buffers
	DBFX	Specify system buffer allocation
DEDB options	OTHR	Specify the number of DEDB updates that can be concurrently waiting for I/O after sync point
	LGNR	Specify the maximum DEDB buffer alterations before CI logging

Table 21. Categories and purpose of Fast Path control region parameters for DCCTL and DB/DC (continued)

Category	Parameter	Purpose
EPCB	EPCB	Specify the size of the EPCB pool
EMHL	EMHL	Specify the size of the EMHL buffer

When an emergency restart is performed, the values specified for the EXEC parameters MSDB, BSIZ, DBBF, OTHR, and LGNR, and the contents of the member DBFMSDBx, must remain unchanged from the last normal start. These values are used when reestablishing buffer contents from checkpoint records.

MSDB loading

The MSDB parameter enables you to control which MSDBs must be loaded for the current online session and how many segments each MSDB requires. The parameter is generated with a null value, implying that the MSDBs are loaded directly from a Fast Path system data set. You specify a one-character suffix that points to an IMS.PROCLIB member, DBFMSDBx, containing the detailed requirements.

If the MSDB requirements for an online session are a subset of the MSDBs, or if the number of segments for any MSDB is to be increased to reserve space for dynamic terminal-related MSDBs, you must coordinate the content of the DBFMSDBx member and the MSDB parameter value. The control statements in the DBFMSDBx member must explicitly name all MSDBs required to be loaded. The control statements also enable you to individually select MSDBs for page fixing.

LU 6.2 devices allow read-only access to dynamic MSDBs. LU 6.2 devices cannot access terminal-related MSDBs.

Terminals defined dynamically with ETO are not available to terminal-related MSDBs.

Database buffer sizes

Using the DBBF and BSIZ parameters, you manually specify the total buffers available for the IMS online system's processing of DEDB activity. Dependent regions then claim portions of this allocation. Use DBFX to specify additional buffers (not separate pools) that are set aside and page-fixed at when the control region is initialized. These buffers allow for asynchronous processing.

If you prefer to have IMS automatically manage Fast Path buffer pools, enable the Fast Path 64-bit buffer manager using the DFSDFxxx PROCLIB member.

DEDB options

The OTHR parameter specifies the number of asynchronous output threads. You can revise the estimate of DEDB updates that occupies buffer space while they are waiting to be committed to the area data sets after sync point logging.

The OTHR= parameter can have any value from 1 to 32,767. If a value is not specified, the default is 255. If 0 or a value greater than 32767 is specified, the default is 2. If a value from 1 to 32767 is specified, the specified value is used.

The LGNR parameter determines a maximum number of individually logged DEDB alterations made in a buffer. Above that number, the whole control interval (CI) is logged. The default value is 7, and you can specify a number from 7 to 99. If the application program is using large CIs, the LGNR value can be increased to economize on the system log activity.

Related reference

[“FASTPATH section of the DFSDFxxx member” on page 788](#)

The FASTPATH section of the DFSDFxxx member specifies options for Fast Path, such as the use of the Fast Path 64-bit buffer manager. The section must begin with the header <SECTION=FASTPATH>. The FASTPATH section is valid in DB/DC and DBCTL environments.

[“Parameter descriptions for IMS procedures” on page 520](#)

All of the parameters that can be specified in startup procedures in the IMS environment are documented in the following subtopics.

Fast Path EXEC parameters in DBCTL

Use Fast Path EXEC parameters to specify database buffer sizes and specify DEDB options in a DBCTL environment.

The PARM1= and PARM2= positional parameters for the control region's EXEC statement that can be used to specify the Fast Path parameters in a DBCTL region are shown below.

Table 22. Categories and purpose of Fast Path control region parameters for DBCTL

Category	Parameter	Purpose
Database buffer sizes	BSIZ	Specify the common size of a buffer
	DBBF	Specify the maximum number of buffers
	DBFX	Specify system buffer allocation
DEDB options	OTHR	Specify the number of DEDB updates that can be concurrently waiting for I/O after sync point
	LGNR	Specify the maximum DEDB buffer alterations before CI logging
EPCB	EPCB	Specify the size of the EPCB pool

When an emergency restart is performed, the values specified for the EXEC parameters BSIZ, DBBF, OTHR, and LGNR must remain unchanged from the last normal start. These values are used when reestablishing buffer contents from checkpoint records.

Database buffer sizes

Using the DBBF and BSIZ parameters, you manually specify the total buffers available for the IMS online system's processing of DEDB activity. Dependent regions then claim portions of this allocation. Use DBFX to specify additional buffers (not separate pools) that are set aside and page-fixed at when the control region is initialized. These buffers allow for asynchronous processing.

If you prefer to have IMS automatically manage Fast Path buffer pools, enable the Fast Path 64-bit buffer manager using the DFSDFxxx PROCLIB member.

DEDB options

The OTHR parameter specifies the number of asynchronous output threads. It allows you to revise the estimate of DEDB updates occupying buffer space while waiting to be committed to the area data sets after sync point logging.

The OTHR= parameter can have any value from 1 to 32,767. If a value is not specified, the default is 255. If 0 or a value greater than 32767 is specified, the default is 2. If a value from 1 to 32767 is specified, the specified value is used.

The LGNR parameter determines a maximum for the number of DEDB alterations made in a buffer that are individually logged. Above that number, the whole control interval (CI) is logged. The default value is 7, and you can specify a number from 7 to 99. If the application program is using large CIs, the LGNR value can be increased to economize on the system log activity.

Related reference

“Parameter descriptions for IMS procedures” on page 520

All of the parameters that can be specified in startup procedures in the IMS environment are documented in the following subtopics.

Fast Path dependent region parameters in DCCTL or DB/DC

The positional parameters (PARM=) for a Fast Path dependent region in DCCTL or DB/DC environments are described in this topic.

Note: The DCCTL environment does not support Fast Path databases. It does support Fast Path processing and transactions.

The PARM= positional parameters for Fast Path dependent region's EXEC statements are shown in [Table 23 on page 185](#).

Table 23. Fast Path dependent region parameters for DCCTL and DB/DC

Category	Parameter
Database and PSB	NBA OBA MBR PSB
Data communications	none
Region control and performance	IFP OPT PRLD PREINIT STIMER DIRCA CPUTIME DBLDL SSM ALTID PARDLI
Recovery and restart	TLIM SOD
Security options	IMSID

The EXEC statement's first positional parameter, IFP, causes this region to be active for Fast Path processing only. The MBR parameter specifies the name of the message-driven application program.

Two database-related parameters, NBA and OBA, control how many of the total Fast Path buffers this region can appropriate for its use. If you are using the Fast Path 64-bit buffer manager, the combined values of NBA and OBA make up the maximum number of buffers reserved for storage. If you are not using the Fast Path 64-bit buffer manager, DBBF controls the maximum number of buffers reserved for storage.

The NBA parameter specifies how many buffers are reserved for DEDB and MSDB processing by this region. This normal allotment is obtained at region startup and must be available from the total number specified for the control region. Specify a number from 1 to 9 999. If you are not using the Fast Path 64-bit buffer manager, coordinate the value across all regions that are to be concurrently active and specify the total on the DBBF parameter. If too few buffers are available from the DBBF total, the dependent

region abends. If you are using the Fast Path 64-bit buffer manager, IMS controls the expansion of the buffer pools, and the DBBF parameter is not valid.

The OBA parameter specifies how many buffers are requested from the control region as overflow when the normal allotment is used up. The control region page fixes the largest number of overflow buffers specified for all active BMPs and CCTL threads. If you are not using the Fast Path 64-bit buffer manager, the buffers are made available to only one program at a time. If you are using the Fast Path 64-bit buffer manager, multiple dependent regions can extend into the overflow buffers concurrently.

Both the NBA and OBA parameters are generated with a 0 (zero) value so that you must respecify the individual values.

Fast Path parameters in BMP and CCTL regions in DBCTL

The Fast Path positional parameters (PARM1= and PARM2=) for batch message processing and CCTL regions in a DBCTL environment are described in this topic.

The PARM1= and PARM2= positional parameters for a BMP region's EXEC statements are shown below. The Fast Path parameters in the DRA startup table that the CCTL must use when it connects to a DBCTL environment are also shown.

Table 24. Fast Path dependent region parameters for DBCTL

Category	Parameter	Purpose
Database and PSB	NBA	Specifies the number of database buffers
	OBA	Specifies the number of overflow buffers
	MBR	Specifies name of message-driven program
	PSB	Specifies PSB name
CCTL	CNBA	Total number of buffers for this CCTL
	FPB	Number of database buffers each thread uses (from the CNBA total)
	FPOB	Number of overflow buffers each thread might need

Two database-related parameters, NBA and OBA, control how many of the total Fast Path buffers this region can appropriate for its use.

The NBA or CNBA parameter specifies how many buffers are reserved for DEDB processing. This normal allotment is obtained at region startup and must be available from the total number specified for the control region. Specify a number from 1 to 9999. If you are not using the Fast Path 64-bit buffer manager, coordinate the value across all regions that are to be concurrently active and specify the total on the DBBF parameter. If too few buffers are available from the DBBF total, the dependent region abends. If you are using the Fast Path 64-bit buffer manager, IMS controls the expansion of the buffer pools, and the DBBF parameter is not valid.

After a CCTL is connected, each CCTL thread request for Fast Path PSBs receives an allotment of buffers.

The OBA or FPOB parameter specifies how many buffers are requested from the control region as overflow when the normal allotment (NBA, FPB) is depleted. The control region page fixes the largest number of overflow buffers specified for all active BMPs and CCTL threads. If you are not using the Fast Path 64-bit buffer manager, the buffers are made available to only one program at a time. If you are using the Fast Path 64-bit buffer manager, multiple dependent regions can extend into the overflow buffers concurrently. Choose a value from 1 to 9999 that is a suitable common value for all regions.

Both the NBA and OBA parameters are generated with a 0 (zero) value so that you must respecify the individual values.

Related reading: For more information about DEDB buffer considerations in a DBCTL environment, see *IMS Version 15.4 Database Administration*.

Online DEDB utility region parameters in DCCTL, DBCTL, or DB/DC

There are several positional parameters used by the Fast Path Online DEDB utility in DCCTL, DBCTL, and DB/DC environments.

The procedure FPUTIL uses the first few positional parameters defined for the IMSFP procedure, but interprets several of the parameters as control for the online DEDB utilities. [Table 25 on page 187](#) shows these parameters.

Table 25. Generated values and purposes for FPUTIL procedure parameters

FPUTIL Parameter	Generated Value	Purpose
IFP	IFP	Specifies Fast Path region
DBD	N/A	Specifies the DEDB name
N/A	DBF#FPU0	Utility program name
REST	00	Restart indicator
N/A	00	No overflow buffers
N/A	Null	Default startup, ask operator
N/A	1	Allows one abend
DIRCA	02	2 KB block for PCB
PRLD	Null	No preload
N/A	0	No time limit

The function performed by the utility depends on the input control statements. A series of DEDB areas can be scanned, have dependent segments deleted, or have the units of work reorganized. If the utility is to be restarted, the REST parameter is coded nonzero.

Recovery-related EXEC parameters for the control region

The EXEC parameters that you can use to control the kind of recovery that is performed for the current system execution include DBRC=, DBRCNM=, QTU=, AND QTL=.

Note: The specifications of the ARC= and WADS= parameters are now in the LOGGER section of the DFSDFxxx PROCLIB member.

DBRC=

Batch and utility regions use the DFSIDEF0 module during initialization. The DFSIDEF0 module that is shipped in the ADFSSMPL library contains a batch and utility region default of DBRC=YES. This value is coded on the DFSIDEF macro.

You are not required to use the DFSIDEF0 module. If you do not use the module, or if the module cannot be loaded at initialization time, IMS defaults to DBRC=YES. Therefore, if DBRC is to be used for your batch and utility regions, then creating the DFSIDEF0 module is not required.

For online environments (DBCTL, DCCTL, or DB/DC), the only valid value is DBRC=YES.

For batch and utilities, you might want to change the default or current value for DBRC.

For batch and utilities, the default is DBRC=Y. To change the default value for DBRC, you can do either of the following:

- Assemble and bind DFSIDEF0 into the IMS execution library; you can specify DBRC=Y, DBRC=N, or DBRC=FORCE. If you specify RMODE, you must specify RMODE=24 and AMODE=24
- Override the value in a DFSPBxxx PROCLIB member. You can specify only DBRC=N or DBRC=Y.

To do this, you must define the RGSUF= parameter in your DLIBATCH or DBBBATCH procedure.

To change the current value for DBRC, override the value in JCL. You can specify only DBRC=N or DBRC=Y.

Sample JCL to assemble and bind the DFSIDEF0 module is shown below:

```
//ASSEMBLE EXEC PGM=ASMA90,PARM='NO0BJ,DECK'  
//SYSLIB DD DSN=IMS.SDFSMAC,DISP=SHR  
//SYSPUNCH DD DISP=OLD,DSN=IMS.OBJDSET(DFSIDEF0)  
//SYSPRINT DD SYSOUT=*  
//SYSUT1 DD UNIT=SYSDA,DISP=(,DELETE),SPACE=(CYL,(15,15))  
//SYSIN DD *  
IDEF0 TITLE 'DFSIDEF0 - IMS INSTALLATION DEFAULTS BLOCK'  
DFSIDEF0 CSECT  
        SPACE 1  
        DFSIDEF TYPE=BEGIN  
        DFSIDEF TYPE=PARAM,DBRC=YES  
***** DFSIDEF TYPE=PARAM,DBRC=NO  
***** DFSIDEF TYPE=PARAM,DBRC=FORCE  
        DFSIDEF TYPE=END  
        END DFSIDEF0  
//STEP1 EXEC PGM=IEWL,  
//        PARM='SIZE=(880K,64K),NCAL,LET,REUS,XREF,LIST'  
//SYSPRINT DD SYSOUT=*  
//SYSPUNCH DD DSN=IMS.OBJDSET,DISP=SHR  
//SYSLMOD DD DSN=IMS.SDFSRESL,DISP=SHR  
//SYSUT1 DD UNIT=(SYSDA,SEP=(SYSLMOD,SYSPUNCH)),SPACE=(CYL,(10,1))  
//SYSLIN DD *  
        INCLUDE SYSPUNCH(DFSIDEF0)  
        NAME DFSIDEF0(R)
```

DBRCNM=

Specify a name (do not accept the default) for the start procedure for the DBRC region on the DBRCNM parameter. The default is a null parameter indicating a procedure name of DBRC. Also as part of your installation's recovery strategy, the AUTO parameter specifies whether to use automatic restart of the IMS online system. You need to override the generated default value (N) by specifying AUTO=Y if you plan to use automatic restart.

QTU= and QTL=

For a non-shared queues environment, the QTU and QTL parameters are associated with protection of the message queues. Use them to adjust the values in the message queue space notification exit routine (DFSQSPCO). Given the number of records reserved on each message queue data set for automatic shutdown (specified in system definition with the SHUTDWN parameter on the MSGQUEUE macro), a finite number of residual records are available for message use. The notification exit routine keeps track of the current level of utilization. If the usage exceeds the upper limit (expressed as a percentage of records used), the MTO is notified so that steps can be taken to reduce the backlog. The MTO is also notified if the usage falls below the lower limit.

For a shared queues environment, the QTU and QTL parameters are used to monitor the device relative record number (DRRN) in-use count. If the high threshold value is reached, a DFS2281I message is issued, and all messages retrieved from shared queues are put in an IWAIT state. When the DRRN in-use count becomes less than the low threshold value, a DFS2282I message is issued, and the messages in an IWAIT state are then posted.

The QTU and QTL values are one or two-digit percentages. QTU overrides the upper threshold value and QTL overrides the lower one (100 is allowed for QTU). Both upper and lower threshold values are generated with null values; the defaults are those of the IBM-supplied exit routine—75% and 60%, respectively. Unless your installation establishes its own exit routine to control the MTO notification, you should probably use these defaults. In the long term, you can tune them to fixed values based on the feedback from the statistics given in the /DISPLAY POOL command; enter this command during peak periods of activity.

Security-related EXEC parameters for the control region

Several parameters control the kind of security checking that is done during the current execution by acting as switches for different types of security.

Moreover, these parameters determine how much flexibility the MTO has to override the choice of security checking. You must coordinate the setting of these switches with both overall security design and operational procedures. The parameters are RCLASS, SECCNT, TRN, SGN, RCF, ISIS, ASOT, ALOT, AOI1, AOIS, and TCORACF.

All the values generated for the IMS procedure parameters specify no security. You need to reset them to match the security design. You must also coordinate the level of the security tables with the suffix identifier for the nucleus.

Related reading: Operational restrictions for the MTO, and the parameter values and their meaning are discussed in *IMS Version 15.4 System Administration*.

The IMSID parameter is partially related to security and to operations. The one- to four-character value that you specify uniquely identifies the control region. Dependent regions executing under control of this nucleus must specify the same identifier. The definition default is IMSA.

Any message sent to the console from subsystem execution is identified by this name; therefore, the name chosen should be unique to other subsystems executing in the z/OS system, including any batch executions. The IMSID name should not be the same as the procedure name in order to avoid confusion as to the source of the message.

EXEC parameters for IMS message processing regions

Using IMS EXEC parameters, you can control many IMS message processing region characteristics including data communications, PSBs, performance, recovery and restart, and security.

These EXEC parameters do not apply to DBCTL.

The PARM= positional parameters for a message processing region's EXEC statement are shown in [Table 26 on page 189](#). See the DFSMPR procedure for more information.

Table 26. Categories and purpose of message processing region parameters

Category	Parameter	Purpose
Database and PSB	PCB	Specify size of pool for PSB copy
	VALCK	Check validity of addresses in DL/I calls
	NBA	Specify Fast Path database buffers
	OBA	Specify Fast Path overflow buffers
Data Communication	CL1	Specify priority of message class
	CL2-4	Specify up to three lower-priority message classes
Region Control and Performance	LOCKMAX	Turn off locking limitations
	MSG	Specify MSG for message region
	OPT	Coordinate region start with control region
	OVLA	Retain overlay supervisor
	PRLD	Specify suffix of DFSMPLxx for program preload
	PREINIT	Specify suffix of DFSINTxx for modules to be preinitialized in readiness for takeover

Table 26. Categories and purpose of message processing region parameters (continued)

Category	Parameter	Purpose
	STIMER	Specify timer options
	DBLDL	Specify maximum number of IMS.PGMLIB directory entries to be saved
	SOD	Specify output class for spin-off dump
	SSM	Specify access to Db2 for z/OS or IBM MQ subsystems
	ALTID	Specify alternate IMS system
	PWFI	Activate pseudo wait-for-input
	APARM	Specify application parameter
Recovery and restart	SPIE	Allow user program SPIE during DL/I call
	TLIM	Specify number of abnormal terminations allowed
Security options	IMSID	Override IMS subsystem identifier

PSB-related EXEC parameters for a message processing region

The PCB parameter is an optional parameter that specifies the size of the interregion communication area. This area holds the PCBs included in the PSBs that are used by programs executing in this region. If you do not specify this parameter, the default value is 000. This allocates an area large enough to hold all the PCBs for the largest PSB defined to this IMS system and present in the active IMS.ACBLIBA/B. To specify a value, enter the number of 1024-byte blocks as a three-digit number (for example, 001).

The default value for the VALCK parameter signifies that address validity checking is not to be performed for DL/I calls issued by the application programs in this region. (An address is invalid if it is either lower than the lowest address not in the z/OS nucleus or higher than the highest address in virtual storage.) With adequate testing of and controls over the DL/I call parameter coding, validity checking should not be necessary.

Data communication EXEC parameters for a message region

A message region requires the set of four parameters, CL1=, CL2=, CL3=, CL4=, to specify transaction classes. Express each class as a three-digit number. The first message class for the region causes all messages assigned to that class to be selected first as eligible for scheduling. Only when all possibility of scheduling a transaction in that class has been exhausted does scheduling begin for the second message class. Priorities determine the order that programs are to be selected for scheduling into the region. The message classes you specify need to be coordinated with your transaction scheduling rules and the numbers entered with the PRTY keyword on the TRANSACT macro.

Region control EXEC parameters for a message region

MSG is the first positional parameter for a message processing region. When transactions are encountered on the queue, programs are automatically scheduled in these regions, if the message class priority is suitable.

The parameter OPT= helps you control the region startup. If, for some reason, the control region is not active or is terminating when the MPP region is invoked, you can have the MTO decide whether to start the MPP region again (the default), let it wait until the control region is ready, or cancel it.

Use STIMER= to invoke timer facilities. If you use the non-default LSO option, LSO=S, both application program and DL/I processing times are recorded. Most DL/I processing time is not included when you

use the default, LSO=Y. A value of 1 causes a timer sequence to be issued once for each DL/I call that can adversely affect the performance of the region. This parameter is used with the TIME= parameter on the //JOB statement.

Recommendation: Because a timeout of a message region causes an abnormal termination of the message region, have processing limits coded within the application program.

Use the SSM= parameter, which is required when using Db2 for z/OS group names to point to a member in IMS.PROCLIB that identifies the Db2 for z/OS subsystems that can be accessed from this MPP region. To prevent any access to subsystems from an MPP scheduled into this region, use the name of a null member (no entries). The SSM= default, a null value, allows the MPP region to attach to any of the subsystems declared to the IMS control region. If necessary, coordinate this parameter with the corresponding SSM parameter in the IMS procedure. Refer to the description in [“System control and performance EXEC parameters for the IMS control region”](#) on page 177.

Use the APARM= parameter to specify execution time parameters unique to this dependent region. This parameter specifies a character string for the application program or Data Capture exit routine. The APARM= can be used to specify the frequency for checkpoint calls. The APARM= can also be used to pass parameters to the Data Capture exit routine to indicate whether the data should be captured.

The maximum length of the parameter is 32 characters; the parameter must be enclosed in single quotation marks (') if special characters are used; embedded commas are not allowed. The INQY call with the ENVIRON or ENVIRON2 subfunctions is used to receive the APARM character string.

Related reading: For more information, see *IMS Version 15.4 Application Programming*.

Use the SOD parameter to specify the output class for a spin-off dump. In this way, you can obtain a printed copy of the storage immediately at abnormal termination of the message region immediately rather than being placed on general SYSOUT queues.

Performance-related EXEC parameters for a message region

Four performance-related options are available. The parameter OVLA= enables you to retain a copy of the overlay supervisor in the message region. The default is to have the overlay control loaded each time you schedule an overlay application program in the region. If you have arranged the message priorities so that an overlay program is likely to be scheduled in the region, you should use this option.

Use the DBLDL= parameter to minimize the cost of program loading by increasing the number of program directory entries maintained in the message region. The effect is to reduce the I/O to the program library (and the search) to obtain the direct address of the program. The default is 20.

Use the PRLD= parameter to specify the two-character suffix of the member DFSMPLxx in IMS.PROCLIB. This member contains the list of programs that are to be preloaded. The effect is to reduce the repetition of I/O for program load. The region address space retains the modules.

PREINIT allows you to specify the two-character suffix of the member DFSINTxx in IMS.PROCLIB. This member contains the preinitialization modules to are to receive control.

The type of program load selected depends on the order of the following:

1. Preload list
2. Standard z/OS fetch

The fourth performance-related parameter is the PWFI= (Pseudo WFI) parameter. Specifying PWFI=Y can potentially reduce CPU time by eliminating the termination and rescheduling of resources. On a message GU call, if MODE=SNGL is specified on the TRANSACT macro and no more messages are available, IMS checks to see if other work needs to be done for the region. If no other work is available and the resources owned by the region are not needed by another region with work to do, the region becomes idle and waits until another message is queued (wait-for-input mode). It does not return a "QC" status code to the application program. If the new message is for the transaction that is scheduled in the region, IMS returns the new message to the application program without having to terminate and reschedule the resources.

If the next message that comes in is not for the transaction that is scheduled in the region, but it can be processed by the region, there is a delay before the new transaction can be processed. Because

termination of the previous message is delayed until after the new message comes in, the region must go through termination before it can schedule the new transaction.

Recovery-related EXEC parameters for a message region

The TLIM parameter addresses a problem with an application program that causes an abnormal termination. Because the program can be scheduled many times into a region as a result of transactions in the queue, you need to be able to stop the operation of this region. The value for TLIM specifies the limiting number of abnormal terminations permitted. In the case where the application program has a SPIE in effect, the SPIE option allows it to be left on during the DL/I call or for it to be turned off during the DL/I call and reinstated when returning to the application program. For performance reasons, it is not recommended to turn it on and off for each DL/I call. With PL/I Release 5 or later, you can use the PL/I SPIE facility without having IMS reset the SPIE on each DL/I call.

Security-related EXEC parameters for a message region

The parameter IMSID is related to security and to operations. You specify the 1- to four-character identifier for the name of the control region (the name given for the IMSID parameter). If the value does not match the current IMSID of any operating control region, the message region is not scheduled.

EXEC parameters for IMS batch message processing regions

Using EXEC parameters, you can override definitions for IMS batch message processing regions that were initially set during IMS system definition, including definitions for databases, PSBs, data communications, region control and performance, recovery and restart, and security.

The PARM= positional parameters for the BMP region's EXEC statement are shown in [Table 27 on page 192](#). See the IMSBATCH procedure for more information.

Table 27. Categories and purpose of BMP region parameters

Category	Parameter	Purpose
Database and PSB	MBR	Specify name of batch message program
	PSB	Specify PSB name
	TEST	Check validity of addresses in DL/I calls
	NBA	Specify Fast Path database buffers
	OBA	Specify Fast Path overflow buffers
Data Communication	IN	Specify an input transaction queue
	OUT	Specify an output transaction queue
Region Control and Performance	BMP	Specify BMP for batch message region
	OPT	Coordinate region start with control region
	LOCKMAX	Specify locking limitations
	PRLD	Specify suffix of DFSMPLxx for program preload
	PREINIT	Specify suffix of DFSINTxx for modules to be preinitialized in readiness for takeover
	STIMER	Specify timer options
	CPUTIME	Specify processing time limit
PARDLI	Specify region for DL/I processing	

Table 27. Categories and purpose of BMP region parameters (continued)

Category	Parameter	Purpose
	DIRCA	Specify interregion communication size
	SSM	Specify access to Db2 for z/OS subsystems
	ALTID	Specify alternate IMS system
	APARM	Specify application parameter
Recovery and Restart	SPIE	Allow user program SPIE during DL/I call
	CKPTID	Specify checkpoint for program restart
Security options	IMSID	Override IMS subsystem identifier

PSB-related EXEC parameters for a batch message region

The MBR= parameter specifies the name of the program and is often the same as the PSB name. This parameter is required. The BMP has flexibility in using a program and PSB combination. This allows you to test modifications of the BMP using a temporary program name. You can also use a different PSB with the same program.

The PSB= parameter is optional if it matches the MBR name. If an APPLCTN macro has been included for the PSB specifying BATCH as the program type, the PSB parameter specifies one of several PSBs for a given BMP. You should identify application programs that can process several types of transactions. These programs often require larger amounts of virtual storage, and you can need to adjust the size of the region.

The TEST= parameter is required, but the IMSBATCH procedure generates a 0 to specify that validity checking of the addresses in a DL/I call is not performed. (An address is invalid if it is either lower than the lowest address not in the z/OS nucleus or higher than the highest address in virtual storage.) Adequate testing of the program and controls over the DL/I call parameter list coding should make the generated option (no validity checking) appropriate.

The NBA= parameter specifies the number of Fast Path database buffers to be made available, up to the maximum number available. If you are using the Fast Path 64-bit buffer manager, it manages the segmentation of the buffer pool into subpools. Otherwise, the buffers are taken from the global pool that is defined by the DBBF= parameter in the IMS control region procedure.

The OBA= parameter specifies the number of additional database buffers to be made available in the CSA/ECSA, up to the maximum number available. Fast Path allocates only the largest OBA specification from all currently active regions. If you are using the Fast Path 64-bit buffer manager, be aware that multiple regions can access the overflow buffers concurrently.

Data communication EXEC parameters for a batch message region

For the batch message program, you have the flexibility of declaring that the input transaction queue is to be made available to the program at execution time. You do this by specifying one transaction code as the value for the IN parameter.

Some BMP programs do not access a message queue; however, they have a requirement to send output to a terminal or to generate transactions to be processed by other application programs. Specify the LTERM name or transaction code (as appropriate) on the OUT parameter.

A null value for the IN parameter prevents the program from accessing message queues. When you specify the transaction code for the IN parameter, the program has no restrictions on generated transactions or output messages.

Region control EXEC parameters for a batch message region

BMP= is the first positional parameter for a batch message processing region. These regions are not scheduled automatically. They must be invoked by the operator.

The OPT= parameter helps you control the start of a batch message region. If the control region is not active when the BMP region is invoked, you must decide whether to wait for a control program, cancel the batch message region, or ask the operator to decide. This might occur when JCL in the z/OS job stream for the BMP region is scheduled before the control region has completed its initialization or when the control region is terminating. Specifying 'wait' is a risk because the z/OS resource is reserved until the control region resumes. If you are starting the region from the master terminal, the default generated for the IMSBATCH procedure is satisfactory.

The optional PRLD= parameter specifies the two-character suffix for the member DFSMPLxx in IMS.PROCLIB, which lists the preloaded modules. It is optional; it is generated as a null parameter for the IMSBATCH procedure. For BMP regions that do not have other programs scheduled in them, PRLD provides no performance gain.

The PREINIT= parameter specifies the two-character suffix of the member DFSINTxx in IMS.PROCLIB. This member contains the preinitialization modules that are to receive control.

The optional STIMER= and CPUTIME= parameters are generated as null parameters, their defaults are no use of the timer.

The optional PCB= parameter specifies the size of the interregion communication area. This area holds the PCBs included in the PSBs that are used by programs executing in this region. If you do not specify this parameter, the default value is 000. This allocates an area large enough to hold all the PCBs for the largest PSB defined to this IMS system and present in the active IMS.ACBLIBA/B. To specify a value, enter the number of 1024-byte blocks as a three-digit number (for example, 001).

Use the SSM parameter to reference a member in IMS.PROCLIB that identifies the Db2 for z/OS subsystems that can be accessed from this BMP region. To prevent any access to a Db2 for z/OS subsystem from the BMP, use the name of a null member (no entries). The default (a null value) allows the BMP region to attach to any of the subsystems declared to the IMS control region. If necessary, coordinate this parameter with the corresponding SSM parameter in the IMS procedure. Refer to the description in [“System control and performance EXEC parameters for the IMS control region”](#) on page 177.

The FMTO= parameter and the type of z/OS dump DD statements selected determine whether IMS dumps are formatted online or offline.

Use the APARM= parameter to specify execution-time parameters unique to this dependent region. This parameter specifies a character string for the application program or Data Capture exit routine. For batch or BMP regions, the APARM= can be used to specify the frequency for checkpoint calls. The APARM= can also be used to pass parameters to the Data Capture exit routine to indicate whether the data should be captured.

The maximum length of the parameter is 32 characters; the parameter must be enclosed in single quotation marks (') if special characters are used; embedded commas are not allowed. The INQY call with the ENVIRON or ENVIRON2 subfunctions is used to receive the APARM character string.

Recovery-related EXEC parameters for a batch message region

For a BMP program, you can use the CKPTID= parameter to set a restart position for the program processing. The IMSBATCH procedure generates CKPTID as a null parameter. To invoke restart, create a special version of the procedure containing the exact checkpoint identification. This can be a 1- to 8-character extended checkpoint identifier generated by the program itself, or a 14-character time stamp identifier issued within a message from checkpoint processing. Alternatively, you can specify the value *LAST* as the identifier to cause the last recorded checkpoint to be used. One technique is to restart BMPs with JCL entered in the system reader and have the CKPTID symbolic parameter coded for the EXEC statement.

Related reading: For more details regarding BMP restart for BMPs that use extended checkpoint, refer to *IMS Version 15.4 Operations and Automation*.

In the case where the application program has a SPIE in effect, you specify whether the SPIE is to remain on or off during the DL/I call. Negated SPIEs are reinstated before returning to the application program.

Recommendation: For performance reasons, do not turn the SPIE on and off for each DL/I call. With PL/I Release 5 and later releases, you can use the PL/I SPIE facility without having IMS reset the SPIE on each DL/I call.

Security-related EXEC parameters for a batch message region

The parameter IMSID is related to security and to operations. You specify the 1-to 4-character identifier for the name of the operational IMS DB/DC environment. If the value does not match the current IMSID of any operating control region, the batch message region is not scheduled.

Chapter 6. Tailoring the IMS system to your environment

Tailoring your IMS system includes tailoring the procedure library, buffer pools, PL/I modules, sequential buffering, high-speed sequential processing, DBCTL, ETO, and HALDB.

Tailoring the sample procedures in the SDFSPROC data set

The SDFSPROC data set provides the sample procedures that used to be generated by sysgen. These sample procedures are now provided as copy source during SMP/E processing.

Running the DFSPROCB job to complete sample procedures

Use the DFSPROCB JCL to create sample procedures that are not delivered during the SMP/E processing in the IMS SDFSPROC library and rename sample procedures whose names do not match what they would have been if they are generated by system definition.

Sample procedures are provided as copy source during SMP/E processing in the IMS SDFSPROC library. However, the following sample procedures are not delivered during SMP/E processing. Use the DFSPROCB JCL to create these sample procedures in the SDFSPROC library during post-SMP/E processing. The JCL can be found in the SMP/E SDFSBASE data set.

- CBLTDLI
- DFSACBCP
- DFSMREC
- FMTCOPY
- PLITDLI
- REFCPY

The DFSPROCB JCL also renames the following sample procedures that are provided during SMP/E processing in SDFSPROC so that they match what they would have been if they are generated by system definition:

- DFSDBDGN to DBDGEN
- DFSIMSBT to IMSBATCH
- DFSPSBGN to PSBGEN

Creating procedures for specific subsystem types

Use the prolog in the sample procedure to modify sample procedures for different system environments.

The sample procedures, in general, assume a 'standard' DB/DC system because the actual system environment is not known. For each procedure that has conditionally-generated statements for 'non-standard' environments, the prolog in the sample procedure includes detailed instructions on how the sample procedure should be modified.

Procedures that have conditional statements for 'non-standard' environments indicates the environment in which the conditional statements apply as follows:

BATCH

The system is BATCH (SYSTEM= (BATCH) is specified in the IMSCTRL macro).

DBCTL

The system is DBCTL (SYSTEM= (DBCTL) is specified in the IMSCTRL macro).

DCCTL

The system is DCCTL (SYSTEM=(DCCTL) is specified in the IMSCTRL macro).

DUAL

Dual data sets for the system log are required.

MFSTEST

The Message Format Service test facility is included (OPTIONS=MFSTEST is specified in the COMM macro or MFSTEST=YES is specified in the IMSGEN macro).

MONITOR

Monitor data set for logging is required

XRF

The system is XRF (HSB=YES is specified in the IMSCTRL macro).

Copying the sample procedures to the PROCLIB data set

If sample procedures are used, copy them from IMS.SDFSPROC to IMS.PROCLIB. Rename and modify as needed so that the procedures match what they would have been if generated by system definition.

Tailoring the IMS PROCLIB data set

Certain members of the IMS PROCLIB data set are provided as copy source during SMP/E processing, and you can copy them from the IMS.SDFSPROC data set. The other members of the IMS PROCLIB data set are built during system definition. The PROCLIB members execute various system operations. You can modify these members to meet your system needs.

Sample procedures that used to be generated by sysgen are generated during SMP/E processing, and you can copy them from IMS.SDFSPROC to IMS.PROCLIB data set. To tailor the IMS PROCLIB data set to meet your system needs, you can modify the IMS PROCLIB data set in one of three ways:

- Tailor the contents of the IMS PROCLIB data set members before implementing Stage 2 system definition.
- Directly alter the contents of the IMS PROCLIB data set members.
- Use the IMS Syntax Checker.

You can update the sample procedures that are in IMS.SDFSPROC to match what they would have been if generated by sysgen.

You might use a parameter in an IMS PROCLIB data set member to enable or disable an IMS function. If a function enablement value, which identifies whether a function is enabled or disabled, is specified both in an IMS PROCLIB data set member and by using the **UPDATE IMSFUNC** command, and then you update the enablement value and restart IMS, the last **UPDATE IMSFUNC** command overrides the value that is specified in the IMS PROCLIB data set member.

Tip: If you enable or disable an IMS function by using the **UPDATE IMSFUNC** command, specify the same enablement value in the parameter that defines the function in the IMS PROCLIB data set member. This ensures that the enablement value for the function is retrieved at IMS cold start.

IMS PROCLIB data set members

The **PROCLIB=** parameter in the IMSGEN macro is no longer used.

The members of the IMS PROCLIB data set can be grouped into several categories depending on their use, as shown in the table that follows.

Table 28. Categories of generated IMS PROCLIB data set members

Category	PROCLIB member	What the member is used for
Online operation	DBC	Executes the DBCTL region
	DBRC	Executes the DBRC address space
	DCC	Executes the DCCTL region
	DFSJBP	Executes the Java™ non-message-driven batch address space
	DFSJMP	Executes the Java message program address space
	DFSMPR	Executes the message processing region
	DFSWTnnn	Prints IMS spool data sets
	DLISAS	Executes the DL/I address space
	DXRJPROC	Executes the IRLM region
	FPUTIL	Executes DEDB utilities online
	IMS	Executes the control region
	IMSBATCH	Executes the batch message region
	IMSFP	Executes the Fast Path dependent region
	IMSMSG	Executes the message region
	IMSRDR	Reads the IMSMSG job
	IMSWTnnn	Executes DFSWTnnn, a procedure that executes the Spool SYSOUT Print utility program (DFSUPRTO)

Table 28. Categories of generated IMS PROCLIB data set members (continued)

Category	PROCLIB member	What the member is used for
Online initialization	DFSCGxxx	Specifies CSL parameters
	DFSDCxxx	Specifies data communication options
	DFSDFxxx	Specifies dynamic resource definitions, diagnostics and statistics, CSL parameters, shared message queue, and CQS address space parameters
	DFSDRFnn	List for defining DREF requirements
	DFSFDRxx	Specifies FDBR region execution parameters
	DFSFIXnn	List for page fixing blocks and modules
	DFSHSBxx	Specifies XRF options used by the active and alternate subsystems in XRF complex
	DFSINTxx	Identifies preinitialization modules
	DFSMP Lxx	Defines a preload program list
	DFSORSxx	Specifies system-related startup parameters for the recovery manager
	DFSPBDBC	Specifies DBCTL execution parameters
	DFSPBDCC	Specifies DCCTL execution parameters
	DFSPBIMS	Specifies DB/DC execution parameters
	DFSSPMxx	Specifies storage pool management parameters
	DFSSQxxx	Specifies shared message queue and CQS address space parameters
	DFSVSMxx	Defines buffer pools, logging attributes, and other options
	DFSYDT	Specifies OTMA descriptors
DFS62DT	Specifies LU 6.2 device descriptors	
Online preparation and maintenance	ACBGEN	Maintains the ACBLIB
	IMSDALOC	Maintains dynamic allocation
	IMSM SV	Offline utility for MSC
	MFS DCT	Maintains MFSDCT and new MFS default formats
	MFS RVC	Maintains MFS service and index
	MFSUTL	Maintains the MFS library. Related procedures include MFSBTCH1/2, MFSTEST, MFSBACK, and MFSREST
	OLCUTL	Prepares IMS for online change
Batch operation	DBBBATCH	Executes stand-alone DL/I batch processing region
	DLIBATCH	Executes stand-alone DL/I batch processing region with block building

Table 28. Categories of generated IMS PROCLIB data set members (continued)

Category	PROCLIB member	What the member is used for
Alternative batch execution	IMSCOBGO	Compiles, binds, and executes (under batch) a COBOL program
	IMSPLIGO	Compiles, binds, and executes (under batch) a PL/I program
Database definition and access	DBDGEN	Maintains the DBDLIB
	DBFMSDBx	Specifies MSDBs
	FPUTIL	Executes online DEDB utilities
	MFDBDUMP	Program to list sample databases
	MFDBLOAD	Batch execution of a program to load the sample databases
Application program preparation	CBLTDLI	Binds control statements for COBOL
	DFSJVMAP	Maps IMS Java application name to OMVS path name for Java class file
	IMSCOBOL	Compiles and binds COBOL program
	IMSPLI	Compiles and binds PL/I program
	PLITDLI	Binds control statements for PL/I
	PSBGEN	Maintains the PSBLIB

Controlling the IMS PROCLIB data set

Carefully examine the procedures generated during SMP/E processing.

Although many of the procedures generated in the IMS.SDFSPROC data set require alteration before they can be used in direct execution of the online system, they do provide a convenient start to the task of defining execution JCL. Many of the members have content that directly indicates the options you specified in the system definition stage 1 input.

You should carefully examine the procedures generated during SMP/E processing.

Renaming the IMS PROCLIB data set members

Rename the IMS PROCLIB data set members according to your installation's requirements. The names can follow a convention that suggests ownership by a particular application system or a convention that has an implied sequence. For example:

IMSIMAG

Initial procedure for image copies of database

IMSCTL

Control region startup (IMS renamed)

IMSTXLD

BMP to preload a transaction queue (IMSBATCH)

IMSMMSG1

Message region startup (IMSMMSG)

IMSBCH1

Low-priority BMP (IMSBATCH)

IMSMMSG2

Second message region when required (IMSMMSG)

IMSWT000

Spool output print procedure (named by IMS)

The system operator or master terminal operator (MTO) uses the procedure names to start the job on z/OS.

To develop these members, you need to either rename the members in the IMS PROCLIB data set or create new members. In some installations, the procedures are added to SYS1.PROCLIB. One option of the NODE keyword on the IMSGEN macro allows you to substitute an alternative library naming convention, so that your base PROCLIB data set can be named LEGAL.PROCLIB.

Altering members of your PROCLIB data set

You must alter the JCL content of the members of the PROCLIB data set. The updates you apply follow naming conventions for your IMS systems and the required DD statements.

Table 29 on page 202 summarizes the ways you can tailor the PROCLIB data set member, excluding arrangements for batch executions. In all procedures, you might want to add JCL comment statements for additional documentation. Your PROCLIB data set might not contain all the members listed below.

Table 29. Tailoring actions for PROCLIB data set members for batch executions

PROCLIB data set member	Tailoring action
IMS	<ul style="list-style-type: none">• Checks and overrides the EXEC PARM parameter.• Specifies region size again.• Moves to SYS1.PROCLIB.• Adds database DD statements, if not dynamically allocated.• Specifies logging data sets again; allows for dynamic allocation.
IMSRDR	<ul style="list-style-type: none">• Adjusts all symbolic parameters for message region start by system operator.• Moves to SYS1.PROCLIB.
DBC	<ul style="list-style-type: none">• Checks and overrides EXEC PARM parameter.• Specifies region size again.• Moves to SYS1.PROCLIB.• Adds database DD statements, if not dynamically allocated.• Specifies logging data sets again, allow for dynamic allocation.
DBRC	<ul style="list-style-type: none">• Adds RECON DD statements, if not dynamically allocated.• Renames the procedure, if desired, and specifies this name with the DBRCNM parameter of the IMS procedure.• Adjusts procedures JCLOUT and JCLPDS.• Moves to SYS1.PROCLIB.
DFSDCxxx	Specifies data communication options.

Table 29. Tailoring actions for PROCLIB data set members for batch executions (continued)

PROCLIB data set member	Tailoring action
DFSFDRxx	<ul style="list-style-type: none"> • Defines the IMSID tracked by the active FDBR. • Defines whether FDBR applies to DEDB areas defined as SHARELVL=0 1. • Defines z/OS cross-system coupling facility group name for the active IMS system and the FDBR tracking region. • Specifies the number of seconds before FDBR goes into timeout status. • Specifies whether control blocks for DEDB processing are allocated in private storage or ECSA.
DLISAS	<ul style="list-style-type: none"> • Adds full-function database DD statements and removes the corresponding statements from the IMS procedure. (No changes are necessary for dynamically allocated databases). • Specifies sizes of two PSB pools using the DLIPSB and CSAPB parameters of the IMS procedure. • Moves the pools to SYS1.PROCLIB. • If the procedure is renamed, specifies this name with the DLINM parameter of the IMS procedure.
IMSMSG	<ul style="list-style-type: none"> • Adjusts JOB statement parameters for DFSMPR execution. • Moves to IMS.JOBS
DFSMPR	Checks and specifies EXEC PARM parameters.
IMSBATCH	<ul style="list-style-type: none"> • Checks and specifies EXEC PARM parameters. • Add z/OS DD statements.
DFSVSMxx	<ul style="list-style-type: none"> • Defines buffer pools and other options. • Allows use of sequential buffering. • Specifies initial WADS and OLDS and dual logging. • Coordinates with IMS procedure. • Enables long busy handling.
DFSHSBxx	Establishes IMS active and alternate subsystems in XRF complex.
DFSDRFxx	Defines DREF requirements list.
DFSFIXxx	Defines page fix list.
DFSINTxx	Defines, loads, and executes user-written exits during dependent region initialization.
DFSMPLxx	Defines preload program list.
DFSSQxxx	<ul style="list-style-type: none"> • Defines PROCLIB data set member for CQS address space. • Defines subsystem name for CQS address space. • Defines name for shared expedited message handler queues. • Defines primary structure containing shared message queues. • Defines XCF IMS shared queues group name.

Table 29. Tailoring actions for PROCLIB data set members for batch executions (continued)

PROCLIB data set member	Tailoring action
IMSWTnnn	<ul style="list-style-type: none"> • Adjusts JOB statement parameters for DFSWTnnn execution. • Moves to IMS.JOBS.
DFSWTnnn	Checks and specifies SYSOUT class for spooled output.
DXRJPROC	Establishes procedures for each required IRLM address space.
DFSPBIMS	<ul style="list-style-type: none"> • Renames to DFSPBxxx, where xxx is determined by IMS procedure RGSUF=xxx. • Defines IMS control region execution parameters.
DFSPBDBC	<ul style="list-style-type: none"> • Renames to DFSPBxxx, where xxx is determined by DBC procedure RGSUF=xxx. • Defines DBC control region execution parameters.
DFSPBDCC	<ul style="list-style-type: none"> • Renames to DFSPBxxx, where xxx is determined by DCC procedure RGSUF=xxx • Defines DCC control region execution parameters.

Preparing for IMS job execution

In preparation for executing the IMS procedure as a system task, the members IMS, IMSRDR, DBC, DCC, DBRC, and DLISAS are moved to SYS1.PROCLIB. Additional members of the IMS PROCLIB data set, especially IMSMSG and the set of IMSWTnnn members for spool output, need to be tailored to satisfy your installation's requirements. IMSMSG invokes the procedure DFSMPR, and the IMSWTnnn members invoke DFSWTnnn. To enable message region and spool output jobs to be started with IMS commands or from the system console, these members, after tailoring, are moved to the IMS.JOBS data set, which is concatenated with SYS1.PROCLIB.

Preparing IMS PROCLIB data set member DFSPBxxx

IMS PROCLIB data set member DFSPBxxx contains IMS control region execution parameters. However, the values specified on the EXEC statement override (but do not nullify) any parameters specified in DFSPBxxx. To build or update a DFSPBxxx member, use the IMS Syntax Checker.

IMS also creates sample DFSPBxxx members during system definition. The sample members are as follows:

- DFSPBIMS for IMS DB/DC
- DFSPBDBC for DBCTL
- DFSPBDCC for DCCTL

These samples contain all the valid parameters for the specified IMS control region. To use the DFSPBxxx member, code RGSUF=xxx on the invocation of the IMS procedure.

Tailoring Fast Path execution procedures in DB/DC or DCCTL

As a result of defining Fast Path application programs in system definition macros, the contents of the IMS PROCLIB data set include two procedures for executing Fast Path dependent regions in a DB/DC or DCCTL environment:

IMSFP

To execute a region containing a Fast Path application program

FPUTIL

To execute online DEDB utilities

You must tailor both of these procedures to the requirements of individual programs. Also, several of the other members of the IMS PROCLIB data set have EXEC statement parameters that specifically apply to Fast Path or need to reflect Fast Path requirements. The additional tailoring actions are summarized in the table below.

Table 30. Tailoring actions for Fast Path procedures

IMS PROCLIB data set member	Tailoring action
IMS	Specify buffering and output thread limits Respecify region size. Add appropriate DEDB DD statements. Allocate MSDB initialization data set.
DFSMPR	Specify buffering reserved for this region.
IMSBATCH	Specify buffering reserved for this region.
IMSFP	Specify the application program and region size. Specify buffering reserved for this region.
FPUTIL	Specify the DEDB name and restart indicator. Provide the utility control statements.
DFSFIXxx	Page fix list for Fast Path control blocks.
DBFMADBx	List of MSDBs and segments to be loaded.

Tailoring Fast Path execution procedures in DBCTL

After defining Fast Path application programs in system definition macros, the contents of the IMS PROCLIB data set in a DBCTL environment include FPUTIL, a procedure that executes online DEDB utilities.

This procedure must be tailored to the requirements of individual programs. Also, several of the other members of the IMS PROCLIB data set have EXEC statement parameters that specifically apply to Fast Path or need to reflect Fast Path requirements. The additional tailoring actions are summarized in the table below.

Table 31. Tailoring actions for Fast Path procedures in a DBCTL environment

IMS PROCLIB data set member	Tailoring action
DBC	Specify buffering and output thread limits Respecify region size Add appropriate DEDB DD statements
IMSBATCH	Specify buffering reserved for this region
FPUTIL	Specify the DEDB name and restart indicator Provide the utility control statements
DFSFIXxx	Page fix list for Fast Path control blocks

Controlling modifications to the IMS PROCLIB data set

Using operator commands keeps the initial operating instructions simple and avoids complex symbolic parameter data entry. However, you must control the exact content of the JCL residing in the IMS PROCLIB data set. For example, the master terminal operator enters:

```
/START REGION IMSBCH1
```

The procedure IMSBCH1 must be correctly coordinated to a known BMP, appropriate PSB and transaction queue, other system options, and identifying parameters.

Your control responsibilities can include auxiliary procedures for database reorganization, recovery, or system output control. Further, the modification level of each procedure must be coordinated to the actual production environment. For example, if an application program is modified and requires more dependent region storage, you must coordinate the program library and IMS PROCLIB data set changes. One technique is to include JCL comment statements that document the date and the reason for the change.

Take special care to check that the physical changes you make in IMS PROCLIB data set members. Many of the DD statements extend over several input records and involve positional parameters, so you need to make more than a cursory examination of a change. You can use a data dictionary to record and maintain the IMS PROCLIB data set members. Changes can then be checked at the terminal or by reviewing listings of the changed members.

Related concepts

[“IMS Syntax Checker” on page 381](#)

The Syntax Checker is an ISPF application that helps you define, verify, and validate parameters and their values in the members of the IMS PROCLIB data set. Use the IMS Syntax Checker to avoid typographical and syntactical errors when modifying the parameter values for the IMS PROCLIB data set members.

IMS buffer pools

Three types of buffer pools control the IMS DL/I buffering services: the VSAM shared resource pool, the OSAM buffer pool, and the OSAM Sequential Buffer (SB) pool.

This topic describes the parameters that define the size and content of the IMS buffer pools. Each data set can have no more than one open ACB (VSAM access method control block).

VSAM constructs the VSAM shared resource pool based on parameters provided by the VSAM BLDVRP macro, which is issued during IMS initialization. This pool contains buffers to be used for VSAM data sets (both index and data components) and the input/output-related control blocks necessary to perform VSAM requests. The buffers are combined in subpools. All buffers within a subpool are of equal length.

The OSAM buffer pool is required for IMS online and batch operations. This pool contains buffers to be used for OSAM data set data components and the input/output-related control blocks necessary to perform OSAM requests. The buffers are combined in subpools. All buffers within a subpool are of equal length.

In addition to defining OSAM and VSAM subpools in the DFSVSMxx member of the IMS PROCLIB data set, OSAM and VSAM subpools can be changed dynamically, while IMS resources are actively in use. Define database buffer pool definitions dynamically by specifying parameters in the DFSDFxxx member of the IMS PROCLIB data set and then issuing a type-2 UPDATE POOL TYPE(DBAS) command.

IMS dynamically constructs the OSAM Sequential Buffer (SB) pool when application programs or utilities using SB are active. To allow online applications to use SB, you must provide a SBONLINE control statement in the DFSVSMxx member of the IMS PROCLIB data set for an IMS DB/DC or DBCTL environment.

Each application program or utility that is using SB has its own SB buffer pools. You can control the use of SB by an application program or utility using either PSBGEN, control statements in the //DFSCCTL data set, or an SB Initialization exit routine.

Related concepts

[Overview of dynamic database buffer pools \(Database Administration\)](#)

[Adjusting OSAM and VSAM database buffers \(Database Administration\)](#)

VSAM subpool definition

VSAM subpools are defined using the VSRBF control statement, one of the control statements in the DFSVSMxx member of the IMS PROCLIB data set.

Define VSAM subpools using the VSRBF control statement, which is described in “DFSVSMxx member of the IMS PROCLIB data set” on page 857. Specify the required subpools in the DFSVSAMP data set for batch environments or in the DFSVSMxx member of the IMS PROCLIB data set for DB/DC environments. The VSAM buffers and control blocks are above the 16-MB line in most environments.

The minimum number of subpools is one and the maximum is 11. The minimum IMS-calculated number of buffers in a subpool is three, and the maximum is 32,767. This calculation is based on region type, number of PCBs, number of data set groups, and database organization.

A database is in sequential mode if all the following conditions are true:

- The database operates in a batch type region (DLI or DBB)
- The database is referred to by only 1 PCB in the PSB
- The database organization is HISAM, single-segment HISAM, INDEX, or HIDAM accessed through unqualified GN calls

Buffer sizes can be 0.5 KB, 1 KB, 2 KB, 4 KB, 8 KB, and multiples of 4 KB up to 32 KB. IMS accepts any valid CI size up to 32 KB, but always uses a buffer size equal to or larger than the CI size. For example, a 30 KB CI uses a 32 KB subpool. If no VSAM files are used, the VSAM subpools need not be defined. A buffer handler pool is always built.

During DL/I database open, a data set is assigned a specific buffer subpool based on the CI size. The CI size must be equal to or less than the buffer size for the subpool assigned. The data and index components of a key-sequenced data set (KSDS) can be assigned to different subpools if their CI sizes are different and corresponding subpools exist. VSAM can assign a larger CI size to the INDEX component than to the DATA component when defining KSDS data sets that have small record sizes. For example, VSAM can assign a 512-byte DATA CI size and a 4096-byte INDEX CI size. You must be sure to define subpools that accommodate both INDEX and DATA components of a KSDS. (A listing of the VSAM catalog shows the CI sizes assigned to the components.) A single subpool can be defined with buffers large enough to contain the longest CI, or you can define several subpools that more nearly fit the different-sized CIs used by the programs.

Related reading: Refer to *IMS Version 15.4 System Administration* for additional information about buffer pool structure and buffering techniques.

Dynamic database buffer pool definition

In addition to defining VSAM subpools in the DFSVSMxx member of the IMS PROCLIB data set, VSAM subpools can be changed dynamically, while IMS resources are actively in use. Define database buffer pool definitions dynamically by specifying parameters in the DFSDFxxx member of the IMS PROCLIB data set and then issuing a type-2 UPDATE POOL TYPE(DBAS) command.

The DFSDFxxx buffer pool values that are brought online dynamically take the place of the values specified in the DFSVSMxxx member. However, the DFSDFxxx member is not read for subpool definitions during IMS startup. The changes made to the DFSDFxxx member are processed only for dynamic changes initiated by the UPDATE POOL TYPE(DBAS) command. The DFSVSMxx member is still required to contain subpool definitions for IMS startup.

Related reference

[UPDATE POOL command \(Commands\)](#)

OSAM subpool definition

OSAM subpools are defined using the IOBF and DBD statements. Specify the required subpools in the DFSVSAMP data set for batch environments, or in the DFSVSMxx member of the IMS PROCLIB data set for DB/DC environments. When using OSAM to access VSAM Linear data sets (LDS), the data is stored in the OSAM buffer pool. Supply enough OSAM buffer pool definitions (IOBF) to hold these data sets.

You can define multiple OSAM subpools as having the same buffer size (that is, the length parameters specified on the IOBF subpool definition statements are identical); then, you can direct given data sets to specific subpools. To take advantage of this flexibility, the subpool must have a user-defined ID (using the ID subparameter) and a DBD statement coded to identify the data set.

If you do not want to assign data sets to specific subpools, do not code the DBD subpool definition statement. If you define multiple OSAM subpools having the same buffer size and ID, IMS generates only one subpool for that buffer size. Within this subpool, the number of buffers is equal to the sum of the number of buffers specified for these subpools. The OSAM buffers and control blocks are above the 16 MB line. In a batch environment, the OSAM buffers and control blocks are located in the private address space. You must allocate a region size that is large enough to accommodate your OSAM buffer requirements.

Dynamic database buffer pool definition

In addition to defining OSAM subpools in the DFSVSMxx member of the IMS PROCLIB data set, OSAM subpools can be changed dynamically, while IMS resources are actively in use. Define database buffer pool definitions dynamically by specifying parameters in the DFSDFxxx member of the IMS PROCLIB data set and then issuing a type-2 UPDATE POOL TYPE(DBAS) command.

The DFSDFxxx buffer pool values that are brought online dynamically take the place of the values specified in the DFSVSMxxx member. However, the DFSDFxxx member is not read for subpool definitions during IMS startup. The changes made to the DFSDFxxx member are processed only for dynamic changes initiated by the UPDATE POOL TYPE(DBAS) command. The DFSVSMxx member must contain subpool definitions for IMS startup.

Related reference

[UPDATE POOL command \(Commands\)](#)

OSAM buffer pool compatibility definition

The OSAM buffer pool consists of one or more subpools that are defined using IOBF parameter statements. These statements are required in a DB/DC environment. Default member DFSVSM00 is used if the VSPEC parameter is not coded, but these statements are optional in a batch environment.

Omitting IOBF statements in a batch environment causes the OSAM subpools to be generated based on the following factors:

- The DMBs loaded for execution
- The values specified by the BUF= parameter on the EXEC statement

The BUF= parameter specifies the size of the OSAM buffer pool that is to be used in the subpool compatibility definition calculations. The size specified by the BUF= parameter does not necessarily define the actual size of the buffer pool. The specified size influences the eventual buffer pool size.

The buffer pool is generated as follows:

- IMS inspects each DMB loaded for execution for an OSAM DCB. The buffer length from the DCB is rounded up to the next appropriate subpool size (.5 KB, 1 KB, 2 KB, and so on) and is used to create a potential subpool. DCBs with similar length requirements increment the occurrence count for that subpool.
- The potential number of buffers for each potential subpool is derived from the ratio of actual to least occurrences, multiplied by 4. The minimum number of buffers allowed per subpool is four.

- IMS allocates the actual number of subpool and buffers according to the previous ratio allocation using the buffer pool size specified by the BUF= parameter. The objective is to allocate at least four buffers per subpool without exceeding the specified size. The process begins with the subpool with the largest buffer size and continues to the subpool with the smallest. Depending on the specified buffer pool size, it might not be possible to generate all required subpools. IMS allocates only those subpools (largest to smallest), with a minimum of four buffers each, that fit in the specified size. A minimum of one subpool with a minimum of four buffers is allocated regardless of the buffer pool size defined. This subpool has a buffer size capable of handling the largest buffer size requirement.

Example: The BUF= parameter is specified as 10 KB. A scan of the loaded DMBs and the block size required by the OSAM DCBs indicates two subpools are required: one with 1 KB buffers, and one with 4 KB buffers. If each subpool has the minimum number of buffers, the total storage for the buffer pool is 20 KB. The size specified (by BUF=) is 10 000 bytes. To support all requests, the subpool having 4 KB buffers must be allocated. The subpool with 1 KB buffers is not allocated. The buffer pool is allocated having one subpool with four 4 KB buffers. The size is 16 KB (plus control areas), even though 10 000 bytes are specified.

Specifying VSAM and OSAM subpools

Use control statements in the DFSVSAMP data set or the DFSVSMxx member of the IMS PROCLIB data set to specify VSAM and OSAM subpools.

The following example shows the control statements to construct a single OSAM subpool with four 2 KB buffers each and two VSAM subpools. The first subpool contains four 2048-byte buffers, and the second subpool contains fifteen 1024-byte buffers. The new KSDS records use mass insert.

```
IOBF=(2K,4,N,N)
VSRBF=2048,4
VSRBF=1024,15
OPTIONS,INSERT=SEQ
```

For information about specifying these control statements, see [“DFSVSMxx member of the IMS PROCLIB data set” on page 857](#).

For IMS batch environments, the //DFSVSAMP data set provides the control statements listed in the example. Additionally, the //DFSVSAMP data set provides the GTF trace option. GTF trace records reflect the stream of I/O requests to the OSAM buffer handler.

In an IMS environment, the DFSVSMxx member of the IMS PROCLIB data set provides the statements. Do not place DFSVSAMP in the same PDS as your user application files. This causes an ABEND0C4 in DFSRTM00. For more information about GTF trace records, refer to *IMS Version 15.4 System Administration*.

Dynamic database buffer pool definition

In addition to defining OSAM and VSAM subpools in the DFSVSMxx member of the IMS PROCLIB data set, OSAM and VSAM subpools can be changed dynamically, while IMS resources are actively in use. Define database buffer pool definitions dynamically by specifying parameters in the DFSDFxxx member of the IMS PROCLIB data set and then issuing a type-2 UPDATE POOL TYPE(DBAS) command.

The DFSDFxxx buffer pool values that are brought online dynamically take the place of the values specified in the DFSVSMxxx member. However, the DFSDFxxx member is not read for subpool definitions during IMS startup. The changes made to the DFSDFxxx member are processed only for dynamic changes initiated by the UPDATE POOL TYPE(DBAS) command. The DFSVSMxx member must contain subpool definitions for IMS startup.

Related reference

[UPDATE POOL command \(Commands\)](#)

Specifications for OSAM sequential buffering

The SBONLINE control statement allows use of OSAM Sequential Buffering (SB) in an IMS DB/DC or DBCTL environment.

For information about specifying the SBONLINE control statement, see [“DFSVMxx member of the IMS PROCLIB data set”](#) on page 857.

One or more of the following factors controls the use of SB by a particular application program or utility:

- PSBGEN
- Control statements in the //DFSCCTL data set
- An SB Initialization exit routine

Related reading: For more information, see *IMS Version 15.4 Database Administration*.

See also [“Specifying sequential buffering control statements”](#) on page 211 for more information about how to request use of SB through control statements in the //DFSCCTL data set of the IMS batch region or IMS dependent online region.

Creating and sizing the 64-bit storage pool

Creating the 64-bit storage pool is a system definition task. Before you can specify an appropriate size on the ACBIN64 parameter in the DFSDFxxx member of the IMS PROCLIB data set, you must perform some calculations.

Before you begin

You can make your calculations based either on DASD allocation or on the sizes of the 31-bit non-resident pool sizes.

About this task

To calculate how much 64-bit storage must be allocated for PSB and DMB ACB members, calculate how much storage is being used for all the non-resident PSBs and non-resident DMBs in the ACB library. DEDB DMBs always reside in 31-bit storage. Since DMBs and PSBs both reside in the same 64-bit pool, sufficient storage must be allocated to accommodate all these members.

Example

The following are some examples:

- The current DASD space allocation for all the non-resident PSBs and non-resident DMBs in the ACB library is 2150 cylinders on a 3390-9, which is approximately 1.9 GB of DASD space. To have sufficient space to include as many ACB members as possible in the 64-bit pool, specify ACBIN64=2.
- There are 57 000 ACB members in the ACBLIB data set. The cumulative size of these ACB members is approximately 850 MB. The size of the non-resident DMB pool is 250 MB. The size of the non-resident PSB pool is 300 MB. Therefore, specify ACBIN64=1.

Making IMS and IMSRDR procedures accessible to z/OS

The IMS and IMSRDR procedures initiate the IMS control program region and message regions. Users can copy the sample procedures to IMS.PROCLIB from IMS.SDFSPROC and must add them to SYS1.PROCLIB.

z/OS with JES2 or JES3: Concatenate IMS.PROCLIB with SYS1.PROCLIB, or move the following procedures to SYS1.PROCLIB:

- IMS
- IMSRDR
- DBC
- DBRC address space procedure

- DL/I address space procedure
- DXRJPROC - IRLM procedure
- DFSMPR
- DFSWTnnn

The IMS PROCLIB data set should be in the master catalog, otherwise, ensure that the volume serial number and unit are on the DD statement. If this is not done, JES2 is unable to initialize.

Any dependent region jobs (IMSMMSG, IMSWTnnn) to be specified in the IMS /START REGION command must be added to IMS.JOBS.

Related reference

[“DBC procedure” on page 604](#)

The DBC procedure is an online execution procedure to initialize the DBCTL environment.

[“DBRC procedure” on page 609](#)

The DBRC procedure is an online execution procedure that initiates DBRC. To take advantage of additional features provided with Base Primitive Environment (BPE) (such as BPE tracing or improved DBRC user exit services), start DBRC in a BPE.

[“DFSMPR procedure” on page 626](#)

The DFSMPR procedure is an online execution procedure that initiates an IMS message processing address space.

[“DLISAS procedure” on page 631](#)

The DLISAS procedure initializes a DL/I separate address space (DLISAS).

[“DXRJPROC procedure” on page 633](#)

The DXRJPROC procedure starts the internal resource lock manager (IRLM). This procedure is supplied on the IRLM distribution tape.

[“IMS procedure” on page 639](#)

The IMS procedure is an online execution procedure that initializes the IMS DB/DC environment.

[“IMSRDR procedure” on page 661](#)

The IMSRDR procedure is used to read an IMSMSG job into the operating system job stream from direct access storage devices (DASDs).

Organizing PL/I modules for use with the PL/I Optimizer

You can decrease response time for those IMS applications that use the PL/I Optimizer by organizing the PL/I modules.

You can organize PL/I modules by:

- Using several different program libraries, one for each region. Put only those modules required by the application in the library. Include in that library all supporting modules (such as the PL/I transient library modules).
- Concatenating the PL/I library into the message region STEPLIB.
- Putting the required supporting modules in the link pack area. This is the recommended long-term solution for a virtual environment.
- Using IMS PRELOAD on the modules.

Attention: Do not use the PL/I Optimizing Compiler for multitasking during binding. Do not use SYS1.PLITASK as a SYSLIB data set.

Specifying sequential buffering control statements

You can use six different sequential buffering control statements, SBPARM, SBIC, SBCO, SBSNAP, SBESNAP, and SNAPDEST, to specify and override definitions related to sequential buffering.

SB control statements allow you to:

- Specify which I/O operations should be buffered by the SB buffer handler
- Override the default number of buffer sets to increase buffering performance
- Experiment with SB specifications without changing exit routines or regenerating the PSB
- Use SB problem determination aids

SB control statements are in a data set with the ddname of //DFSCTL. You can provide a //DFSCTL DD statement in the JCL of the IMS batch or IMS dependent online region. The //DFSCTL DD statement must point to a sequential data set or a member of a partitioned data set. The record format of the //DFSCTL data set must be F, FB, or FBS.

Sequential buffering can be invoked by default for IMS utilities, such as online image copy, without requiring SB control statements, through the use of the SB Initialization exit routine.

Related reading:

- For the syntax and keywords associated with the SB control statements, see [“Sequential buffering control statements” on page 957](#).
- For the description of the SB Initialization exit routine, see *IMS Version 15.4 Exit Routines*.

Using high-speed sequential processing control statements

The following is an introduction to high-speed sequential processing (HSSP) control statements.

HSSP control statements allow you to:

- Set up the environment in which you process a selected PCB with HSSP
- Create an image copy of a designated DEDB area, reducing the amount of logged data
- Restrict access of a specific HSSP or non-HSSP application program to only designated DEDB areas
- Specify whether the utility private buffers are allocated in 31-bit extended common storage (ECSA) or 64-bit common storage

You can specify the following HSSP control statements:

SETO

The SETO control statement allows you to specify the options in processing a PCB with HSSP.

SETR

The SETR control statement specifies the processing range of PCBs to a database during scheduling of an application program. If a PSB has several PCBs pointing to the same database, you can restrict the access of each PCB to that database. Each program can only access data in the DEDB within the range defined.

SETU

The SETU control statement specifies whether the utility private buffers are allocated in 31-bit extended common storage (ECSA) or 64-bit common storage. If the statement is not specified, the buffers are allocated in ECSA.

HSSO, HSSR, and HSSD control blocks are built from SETO and SETR statements. These control blocks—specifically those that represent image copy data sets and those that are used for UOW locking—are formatted for offline dumps. These control statements are in the DFSCTL data set.

Related reading: For the syntax and keywords associated with the HSSP control statements, see [“High-speed sequential processing control statements” on page 963](#).

Supporting CCTL users with DBCTL databases

DBCTL is an IMS facility that allows access to DL/I full-function databases, HALDB, and data entry databases (DEDBs) from a subsystem called a coordinator controller subsystem (CCTL).

A CCTL is the transaction management subsystem that communicates with DBCTL using the database resource adapter (DRA).

“Preparing a CCTL” on page 213 describes the installation tasks required of the CCTL to enable the DRA.

Related reading: See *IMS Version 15.4 Communications and Connections* for information about CCTL programming requirements for using the DRA interface and installation concerns related to IBM CICS® Transaction Server for z/OS as a CCTL.

Figure 13 on page 213 illustrates the relationship of the DRA interface, CCTL, and DBCTL.

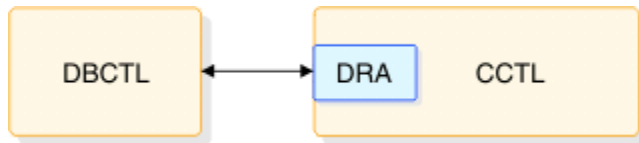

Figure 13. DRA interface to DBCTL

As part of the DBCTL definition process, you should consider CCTL requirements such as database, PSB, or buffer pools. For sample input for DBCTL stage 1 definition, see “[IMS DBCTL environment](#)” on page 380.

For a CCTL that is connected to DBCTL, **LSO=S** must be specified on the IMS procedure so that the DL/I separate address space (DLISAS) is used.

Related concepts

“[Using a DL/I separate address space](#)” on page 105

The DL/I separate address space (DLISAS) is used by the online IMS control program to contain most of the DL/I code and control blocks. For some system configurations, using a DLISAS is required.

Related reference

“[LSO= parameter for procedures](#)” on page 551

Use the LSO= parameter in procedure to specify whether to use the Local Storage Option (LSO) or the DL/I subordinate address space option. Valid values are Y, and S. The default is Y.

Preparing a CCTL

You must take steps to prepare a CCTL for enabling a DRA environment.

About this task

Perform the following procedure:

Procedure

1. Confirm that the DRA startup/router routine (DFSPRRCO) is in a CCTL load library. The routine can be copied from the IMS.SDFSRESL, which is built by the IMS definition process. Alternately, the IMS.SDFSRESL can be concatenated in the CCTL step library.
2. Confirm that the DFSPZPxx load module is in a CCTL load library; this load module is the DRA startup table.

The xx is the startup table name suffix that the CCTL specifies on the DRA initialization request. The source code for DFSPZPxx is DFSPZP00 in the IMS distribution library, DLIB. After all modifications have been made to DFSPZPxx, it is assembled using IMS DLIBS. A default load module, DFSPZP00, is in the IMS.SDFSRESL. It has default values for all but two of the required DRA initialization parameters, all of which can be overridden on the initialization (INIT) request itself.

The rest of the DRA code must reside in a load library that is dynamically allocated by DFSPRRCO. The DDNAME and DSNAME of this load library are specified in the startup table or initialization request. The default DSNAME is IMS.SDFSRESL because all DRA code resides here throughout the IMS definition process.

Results

Related reading: For the sample source code for DFSPZP00 and explanations of the parameters specified through the DFSPRP macro, see [“Database resource adapter startup table for CCTL regions” on page 968.](#)

Enabling IMS ETO for ACF/VTAM terminals

IMS Extended Terminal Option (IMS ETO) requires at least one user descriptor and one logon descriptor.

Related reference

[“DFSDSCMx member of the IMS PROCLIB data set” on page 815](#)

When the Extended Terminal Option (ETO) is enabled, IMS generates ETO descriptors during stage 1 system definition and stores them in the DFSDSCMx member of the IMS.PROCLIB data set.

[“DFSDSCTy member of the IMS PROCLIB data set” on page 827](#)

Use the DFSDSCTy member of the IMS PROCLIB data set to specify override descriptors for the Extended Terminal Option (ETO), including logon descriptors, MFS device descriptors, MSC descriptors, and user descriptors.

ETO descriptors

When you are enabling ETO support in your installation, you can optionally request that IMS produce ETO descriptors during system definition. You do this with the ETOFEAT keyword in the IMSCTRL macro.

Descriptors contain information about terminal devices and users that is required to establish dynamic sessions. Four types of descriptors are:

- Logon
- MFS Device
- MSC
- User

Descriptors that are created during system definition are placed in member DFSDSCMx, which resides in the IMS.PROCLIB data set. If you perform subsequent system definitions of the same stage 1 input deck, the DFSDSCMx members are overwritten. If you use TSO or a z/OS utility to create descriptors, you can place the descriptors in member DFSDSCTx to avoid loss when member DFSDSCMx is replaced. You can also use TSO or an z/OS utility to update descriptors in DFSDSCMx that were created during system definition.

The suffix for DFSDSCMx is always the nucleus suffix. The default suffix for DFSDSCTy defaults to 0; however, you can specify it with the DSCT= JCL parameter. Each descriptor statement must be 80 characters in length. All statements are translated to uppercase.

Related tasks

[Administering the Extended Terminal Option \(Communications and Connections\)](#)

Related reference

[“IMSCTRL macro” on page 427](#)

Use the IMSCTRL macro statement to describe the basic IMS control program options, the z/OS system configuration under which IMS is to execute, and the type and class of IMS system definition to be performed.

[Transaction Manager exit routines \(Exit Routines\)](#)

[“DFSDSCMx member of the IMS PROCLIB data set” on page 815](#)

When the Extended Terminal Option (ETO) is enabled, IMS generates ETO descriptors during stage 1 system definition and stores them in the DFSDSCMx member of the IMS.PROCLIB data set.

ETO descriptor definition rules

Follow these rules when defining ETO descriptors.

- Separate one keyword or parameter set from another with one or more blanks.
- Do not include embedded blanks within a keyword and its parameters.

- Separate a keyword from its parameters with an equal sign (=).
- Do not abbreviate keywords.
- Separate multiple parameters for single keywords with commas.
- Specify at least one parameter for each keyword.
- No more than 512,000 records (excluding comments) are permitted for each individual descriptor.

You can continue a keyword and its parameter set to the next statement if no intervening blanks appear at the end of the first statement or at the beginning of the parameters of the next statement. A continued statement still has the same descriptor type and name in columns 1-10; the continued specification begins in column 12. If you specify keywords, they must be accompanied by parameters. Keywords followed by blanks or commas are invalid.

Parentheses are optional if they follow a keyword that supports multiple parameters and only if the first parameter is specified. Otherwise, they are required.

If the keyword has positional parameters, you can use commas when parameters are specified after a missing positional parameter. Following is an example of valid use:

```
LTERMA=(ABC,,1)
```

This example is valid because LTERMA has positional parameters.

The following example is invalid:

```
LTERMB=(ABC,,1,)  
OPTIONS=(TRANSRESP,)  
OPTIONS=(,SYSINFO)
```

The LTERMB example is invalid because the comma must be followed by a parameter. The OPTIONS examples are invalid because the parameters for the OPTIONS keyword are not positional.

ETO descriptor overrides

If a descriptor is defined in both DFSDSCTy and DFSDSCMx, the descriptor in member DFSDSCTy overrides the descriptor in member DFSDSCMx.

No message is issued.

If a descriptor is defined more than once in either member, error message DFS3661 is issued. IMS uses the last descriptor defined. If the same descriptor is defined once in member DFSDSCTy and one or more times in member DFSDSCMx, the descriptor in member DFSDSCTy is used, and no error message is issued.

Logon descriptors

Logon descriptors provide IMS with information about the physical characteristics of the terminals that establish logon sessions.

When you request that ETO descriptors be created during system definition, a logon descriptor is created for each VTAM TYPE and TERMINAL macro set.

IMS also creates a default logon descriptor during system definition, which reflects the TYPE and TERMINAL macro statements that define the unique characteristics of the largest number of terminals of that type.

For terminals that cannot be represented by the default logon descriptor, IMS creates unique logon descriptors.

IMS does not create ETO logon descriptors for the following terminal types:

- Any terminal defined as a primary or secondary MTO
- Any LUTYPE6 terminal defined as the XRF ISC link

You can keep and use the unique logon descriptors that IMS creates or you can discard them. To discard the unique logon descriptors you can:

- Operate the terminals based on the default logon descriptor
- Create one or more of your own installation default logon descriptors and code an installation Logon exit routine (DFSLGNX0) to select the required descriptor for logging on to a terminal

The system definition process generates up to 37 default logon descriptors for each device type. The suffix for each descriptor defaults to 0; the last character of the descriptor name ensures that the name is unique. This character is a blank for the most common descriptors, and then 0 through 9, and A through Z, for a total of 37 possible descriptors.

Terminal definitions that do not match the 37 most common terminal definitions generate comment statements with an asterisk in the first position and the rest of the statement is shifted over one position.

All user descriptors created during system definition are generated as comment statements to avoid getting error messages caused by a statically defined LTERM name.

Typically, one generic logon descriptor exists per unique LU type and option configuration. After the descriptor is created, the same descriptor can support any number of logons for the same LU type and option configuration.

The format of a logon descriptor is

```
L Descriptor name Parm(1) Parm(2) Parm(3)
L Descriptor name Parm(4) Parm(5) Parm(n)
```

The parameters that are required for a descriptor cannot fit into one record. You might need to use multiple records with the same descriptor name to define your descriptor.

Related tasks

[Creating logon descriptors \(Communications and Connections\)](#)

MFS device descriptors

Use MFS device descriptors to define characteristics of terminals added dynamically that have different characteristics from statically defined terminals.

MFS device descriptors are used by the MFS Device Characteristics Table (DCT) utility. This utility updates screen information, for example 3270 screen sizes and feature information, in the DCT and generates new MFS default formats without system definition.

Related reading: See *IMS Version 15.4 System Utilities* for more information about how to use the MFS DCT utility.

MFS device descriptor format

The format of an MFS device descriptor is

```
D Descriptor name Parm(1) Parm(2) Parm(3)
```

MFS device descriptor parameters

The three parameters supported for MFS device descriptors are TYPE=, SIZE=, and FEAT=.

Example of MFS device descriptors

```
Col      Col
1        12
D        TYPE=3270-A04 SIZE=(43,80) FEAT=IGNORE
```

See the parameter descriptions in [“Parameter descriptions for IMS procedures” on page 520](#) for more information.

MSC descriptors

MSC descriptors relate remote NAME macros to MSC links defined during system definition.

When you use ETOFEAT to specify that descriptors are to be created during system definition, an MSC descriptor is created for each MSNAME macro statement.

MSC descriptor format

The format of an MSC descriptor is

```
M Link name name1 name2 namen
```

An MSC descriptor contains a link name rather than a descriptor name. The link name is the name of the retrieved descriptor. The name parameters represent any valid remote LTERM name that can be accessed through a link name. The parameters that are required for a link name cannot fit into one record. You might need to use multiple records with the same link name to define your descriptor.

MSC descriptor parameters

The parameters that are supported for MSC descriptors are as follows:

descriptor type

Specifies that the descriptor is MSC (M).

descriptor name

Specifies the link name from the MSNAME macro.

remote LTERM name

Specifies the name of a logical terminal associated with a physical terminal defined in a remote IMS system.

User descriptors

User descriptors are another form of descriptor created during system definition for ETO. Node user descriptors are essentially migration aids, allowing message queues and options associated with a particular terminal to remain unchanged during migration.

User descriptors are another form of descriptor created during system definition for ETO. Three types of user descriptors are:

- DFSUSER
- Node
- Installation-created

The node user descriptors are essentially migration aids, allowing message queues and options associated with a particular terminal to remain unchanged during migration. They do not, however, provide output security.

Related reading: For information about the format of user descriptors, refer to *IMS Version 15.4 Communications and Connections*.

User descriptors are generated from each VTAM TERMINAL or VTAMPOOL SUBPOOL macro statement. Those descriptors created from VTAM TERMINAL macro statements, such as node user descriptors, have the same name as the terminal. Descriptors created from VTAMPOOL SUBPOOL macro statements have the same name as the subpool.

For user descriptors created during IMS system definition from the SUBPOOL macro statement, the response option (TRANSRESP, NORESP, or FORCRESP) cannot be set. This is because the response option is defined on the TERMINAL statement for static definitions. You need to add the appropriate response option for your installation to any user descriptor created from a SUBPOOL statement.

DFSUSER descriptor

When you request that IMS build ETO descriptors, IMS creates a single default user descriptor, DFSUSER, which defines default user characteristics. The DFSUSER descriptor represents the most common set of user options. With this descriptor, IMS can dynamically create a user and message queue structure for a signon request when no other user descriptor is available. The message queue name is the same as the user ID. You can also use DFSUSER to add queue names and other options through the DFSSGNX0 Signon exit routine.

Related reading: Refer to *IMS Version 15.4 Exit Routines* for more information about how to use the DFSSGNX0 exit routine.

Recommendation: Use the DFSUSER descriptor for most of your users after your migration to ETO is completed.

Node user descriptors

Node user descriptors are created during system definition. One is generated for each terminal in the IMS system definition. Node user descriptors are created even if they match DFSUSER options, except for ISC terminals defined for parallel-session support.

Installation-created descriptors

Installation-created user descriptors are designed by your installation to meet your criteria. The name of the installation-created user descriptor is the same as the user ID.

User descriptor format

The format for a user descriptor, regardless of whether it is created by installation, node, or DFSUSER, is:

```
U username parm1 parm2 parm n
```

U is the descriptor type (USER), and Username is DFSUSER, the user ID, or the node user name from the name field in the TERMINAL or SUBPOOL macro statement supplied by the installation.

parm (1 . . . n) can be any of the following parameters: ASOT=, LTERM=, OPTIONS=, AUTLGN=, AUTLMOD=, AUTLDESC=, AUTLID=

Specifying the number of hash table slots

The number of hash table slots that IMS builds for a statically defined resource depends on the total number of resources; you can specify additional slots.

The number of hash table slots built by IMS for a statically defined resource (such as LTERMs, physical terminals, and users) is one-eighth the total number of the resource. To specify additional slots required for a resource created dynamically (conversations, LTERMs, physical terminals, and users), as a rule-of-thumb use one-eighth of the estimated total number of a dynamic resource. You might need to adjust this value. For information about setting the number of slots for specific hash tables, see the LHTS, NHTS, and UHTS parameters in [“IMS procedure” on page 639](#) and [“DCC procedure” on page 611](#).

HALDB selective partition processing

You can restrict the processing of DL/I calls to a single HALDB partition or a range of HALDB partitions by using a DD statement with the ddname DFSHALDB to pass control statements. DFSHALDB must be

provided in the JCL of the batch job, the BMP (Batch Message Processing dependent online region), or the JBP (Java Batch Processing dependent online region).

Control Statements for HALDB selective partition processing

➔ HALDB PCB= (*nnnn* , *ppppppp*) ➔
ddddddddd *NUM=yyy*

Each HALDB control statement must have a PCB keyword that contains the required parameters. The required parameters for an individual control statement must be on one line; no continuation is allowed. The input can consist of multiple HALDB control statements. There should be no duplication of DB PCB numbers. In the event of a duplication, the control statement that has been read the most recently overrides the previous statement.

Any HALDB control statement that is syntactically correct results in an entry within a table. The maximum number of entries in the table is 20. All subsequent statements that are read, even though syntactically correct, are ignored and result in a U0201 abend, unless a statement is a duplicate of an entry that is already in the table.

Parameter descriptions for HALDB selective partition processing

nnnn

The DB PCB number as the relative number of the DB PCB defined in the PSB.

ddddddddd

The DB PCB label or name.

ppppppp

The partition name. This parameter is required.

NUM=yyy

The range of consecutive partitions that this PCB is restricted to using, starting with the named partition. The range of consecutive partitions is defined as the partition selection order, which is the next partition selected starting from the target partition named in the DFSHALDB statement. The next partition is determined using either the high keys defined for the HALDB or the processing order defined by the partition selection exit. This parameter is optional.

The following examples show how to use HALDB selective partition processing statements.

DFSHALDB for single partition restriction

```
HALDB PCB=(4,POHIDKA)  
HALDB PCB=(PCBNUM2,POHIDJA)
```

DFSHALDB for range partition restriction

```
HALDB PCB=(3,PVHDJ5A,NUM=4)  
HALDB PCB=(PCBNUM7,PVHDJ5B,NUM=3)
```

Report generated for HALDB selective partition processing

When you use HALDB selective partition processing, a report called “HALDB Selective Partition Processing” is generated in the SYSHALDB data set. This report shows the control statements that have been issued and the reason for accepting or rejecting each statement. Control statements that have been validated and accepted are shown as “Syntactically correct.” Other messages that might appear for syntactically correct statements, and their accompanying messages, are shown in the following table:

Table 32. Messages provided in the report generated for HALDB selective partition processing

Message	Explanation
Duplicate, overrides previous statement	A HALDB statement for the same PCB was already found. The current statement overrides the previous HALDB statement.
Ignored, number of valid statements exceeds 20	More than 20 HALDB statements were provided, but only 20 statements are allowed. Reduce the number of HALDB statements to 20 or fewer, and run the job again. This message results in an abend U0201.
NUM parameter must be non-zero numeric	The partition range specified in the NUM keyword must be a non-zero value from 1 to 999.
NUM value exceeds three digits	The partition range specified in the NUM keyword must be a non-zero value from 1 to 999.
An equal sign must follow NUM keyword	An equal sign must follow the NUM keyword in the HALDB statement. Add an equal sign to the HALDB statement.
The NUM keyword is missing	A comma was found after the partition name, but the NUM keyword was not present. Either verify the syntax of the positional parameters in the HALDB statement, or add the NUM keyword and the range of partitions for the restriction.
NUM parameter is missing	The NUM keyword was found, but the NUM parameter value was not present. Either verify the syntax of the positional parameters in the HALDB statement, or add the NUM keyword and the range of partitions for the restriction.

For HALDB control statements that are not syntactically correct (statements that are processed and rejected), the messages and explanations that are issued are shown in the following table:

Table 33. Messages provided in the report generated for syntactically incorrect HALDB statements

Message	Explanation
No HALDB statement type	The DFSHALDB data set did not contain a HALDB statement. Add a HALDB statement to prevent this error.
A space must follow HALDB statement type	The HALDB statement requires a space after HALDB and before the PCB keyword.
PCB keyword missing	The required keyword PCB was not found. The PCB keyword must be present to process the HALDB statement successfully.
Equal sign must follow PCB keyword	An equal sign did not follow the PCB keyword. The equal sign must follow the PCB keyword to process the HALDB statement successfully.
Open parenthesis must follow equal sign	An open parenthesis did not follow PCB=. The open parenthesis must follow the PCB= to process the HALDB statement successfully.

Table 33. Messages provided in the report generated for syntactically incorrect HALDB statements (continued)

Message	Explanation
Second parameter may be missing	The HALDB partition must be provided. Either add the partition name, or verify that the syntax of the positional parameters is correct.
First parameter exceeds four digits	The DB PCB number cannot exceed a four-digit value. Change the DB PCB number to the correct DB PCB number.
Delimiter is not a comma	A comma is missing between parameter values. The comma is used as a delimiter for the positional parameters. Either add the comma, or verify that the syntax of the positional parameters is correct.
Partition name must start with an alpha	The HALDB partition name must begin with a alphabetic character. Add the partition name or verify the syntax of the positional parameters is correct.
Delimiter is not a close parenthesis	A closing parenthesis is missing from the HALDB statement. Add a closing parenthesis around the PCB parameters.
Partition name exceeds seven characters	The HALDB partition name must be seven or fewer characters. Either add the partition name, or verify that the syntax of the positional parameters is correct.
Invalid character in partition name	The HALDB partition name contains an invalid character. Either add the partition name, or verify that the syntax of the positional parameters is correct.
Statement contains all spaces	The HALDB statement is missing. Add a valid HALDB statement.
Invalid statement input	A HALDB statement was found, but it does not appear to be complete. Verify the syntax of the HALDB statement and the positional parameters specified.
Space must follow close parenthesis	A space must follow the closing parenthesis. Add a space after the closing parenthesis.
First parameter missing	The PCB number or label is missing. Either add the PCB name or label, or verify that the syntax of the positional parameters is correct.
Comma and part name missing	Only the PCB number or label was provided in the HALDB statement. Either add the partition name, or verify that the syntax of the positional parameters is correct.
Partition name is missing	The HALDB partition name must be provided in the HALDB statement. Either add the partition name, or verify that the syntax of the positional parameters is correct.

Table 33. Messages provided in the report generated for syntactically incorrect HALDB statements (continued)

Message	Explanation
Partition name starts with numeric	The HALDB partition name must begin with an alphabetic character. Either add the partition name, or verify that the syntax of the positional parameters is correct.
First parameter must not be zero	The PCB number must be a non-zero number. Add a non-zero number for the DB PCB number.
Comment statement	An asterisk was found in column one of the HALDB statement. This statement was skipped and considered a comment.

After all of the statements are validated, the job abnormally terminates with an abend code of U0201.

Capturing JVM usage statistics

You can enable IMS to capture the usage statistics of persistent Java virtual machines (JVMs) that run in an IMS dependent region. The JVM usage statistics are captured as type-29, subtype-2 records in z/OS System Management Facility (SMF).

Before you begin

Before you enable IMS to capture JVM usage statistics, ensure that all of the following prerequisites are met:

- The latest version of the IMS Universal JDBC driver is downloaded and all of your existing IMS Universal JDBC driver files are replaced with the files of the latest version. In particular, you must use the latest version of the `imsudb.jar` and `imsutm.jar` files.
- SMF is installed in z/OS.
- SMF is configured to accept type-29, subtype-2 records in the settings for SMF parameter `SYS1.PARMLIB(SMFPRMxx)` in z/OS.
- Define the `BPX.SMF` or the `BPX.SMF.type.subtype FACILITY` class profile according to your needs. Defining the `BPX.SMF.29.2 FACILITY` class profile requires a clean program-controlled environment. For more information about defining `BPX.SMF` or `BPX.SMF.type.subtype`, see [z/OS UNIX System Services Planning on setting up the UNIX-related FACILITY and SURROGAT class profiles](#).

For example, once you have activated the `FACILITY` class with the `SETROPTS CLASSACT FACILITY` command, you can use the commands below to permit access to either `BPX.SMF` or `BPX.SMF.29.2`. Please see the documentation for each of those commands for more details:

- `RDEFINE FACILITY BPX.SMF UACC (access-authority)`
- `PERMIT BPX.SMF CLASS (FACILITY) ACCESS (access-authority) ID (name)`
- `SETROPTS RACLIST (FACILITY) REFRESH`

Or

- `RDEFINE FACILITY BPX.SMF.29.2 UACC (access-authority)`
- `PERMIT BPX.SMF.29.2 CLASS (FACILITY) ACCESS (access-authority) ID (name)`
- `SETROPTS RACLIST (FACILITY) REFRESH`

IMS queries z/OS to confirm that SMF type-29, subtype-2 records are to be captured. If not, IMS does not call SMF to write the record.

Procedure

To enable IMS to capture JVM statistics, specify the following parameters in the DFSJVMEV member of the IMS PROCLIB data set or, if you use the //STDENV DD statement to configure JVM environments, in the shell script that is referenced by the DD statement.

JLEOPT=N

Specifies that a persistent JVM is used for the IMS dependent region.

SMFINTERVAL

Specifies the time interval in milliseconds that is used to log JVM statistics. 6000 is the recommended value.

Format of an SMF type-29, subtype-2 record

JVM usage statistics are captured as type-29, subtype-2 records in z/OS System Management Facility (SMF). The SMF record consists of three main sections: the SMF header, the BPE header, and the section for JVM usage statistics.

The BPESMF29 macro contains the DSECTs for both the SMF type-29 and the BPE headers. The smf29bhs field in the SMF header contains the offset from the start of the SMF 29 record to the BPE header.

The DFSJSMF macro contains the DSECT for the JVM usage statistics. The smf29sts field in the SMF header contains the offset from the start of the SMF 29 record to the JVM usage statistics.

The following tables describe the fields for each section of the SMF 29, subtype-2 record.

Name	Length	Type	Description
smf29len	2	binary	Record length
smf29seg	2	binary	Segment descriptor
smf29flg	1	binary	System indicator flag: <ul style="list-style-type: none">• x'80' – Reserved• x'40' – Subtype used• x'20' – Reserved• x'10' – MVS/SP version 4 and above• x'08' – MVS/SP version 3• x'04' – MVS/SP Version 2• x'02' – VS2• x'01' – Reserved
smf29rty	1	binary	Record type (29 decimal or x'1D')
smf29tme	4	binary	Time since midnight, in hundredths of a second, that the record was moved into the SMF buffer
smf29dte	4	packed	Date (packed decimal) when the record was moved into the SMF buffer
smf29sid	4	EBCDIC	System identification
smf29ssi	4	EBCDIC	Subsystem identification
smf29sty	2	binary	Record subtype. The subtype code for an SMF type-29, subtype-2 record is SMF29_STY_002.
smf29trn	2	binary	Number of triplets in this record
*	2		Reserved
smf29bhs	4	binary	Offset to BPE header from start of record

Table 34. SMF type-29 header - BPESMF29 DSECT (continued)

Name	Length	Type	Description
smf29bhl	2	binary	Length of BPE header
smf29bhn	2	binary	Number of BPE header
smf29sts	4	binary	Offset to subtype specific section from start of record
smf29stl	2	binary	Length of subtype specific section
smf29stn	2	binary	Number of subtype specific section

Table 35. BPE header - BPESMF29_BPEHDR DSECT

Name	Length	Type	Description
smf29bh_fieldFlags	4	binary	Field flags
smf29bh_asType	4	EBCDIC	Address space type that wrote this record
smf29bh_jobName	8	EBCDIC	Job or started task name
smf29bh_asName	8	EBCDIC	<ol style="list-style-type: none"> 1. IMSID (or DBCTL RSENAME) for batch/ IMS control region-associated address spaces (CTL, DLI, DBRC, DEP) 2. BPE address space "system name" for BPE-managed address spaces
smf29bh_crType	1	binary	Associated control region type: <ul style="list-style-type: none"> • x'00' – Not a control-region address space • x'01' – TM/DB IMS • x'02' – DBCTL IMS • x'03' – DCCTL IMS • x'04' – FDBR region
smf29bh_flag1	1	binary	Flag byte: <ul style="list-style-type: none"> • x'80' – IMS or BPE address space registered as VUE • x'40' – Record written by IMS dependent region or DBCTL/ODBA thread • x'20' – Record written by IMS batch region • x'10' – IMS using IRLM • x'08' – IMS using DBRC • x'04' – IMS using shared queues • x'02' – IMS using CSL • x'01' – Reserved
*	2		Reserved
smf29bh_asVersion	3	EBCDIC	Address space version number (binary)
smf29bh_bpeVersion	3	EBCDIC	BPE version number or 0 (binary)
smf29bh_asid	2	binary	ASID of the address space that wrote this record
*	4		Reserved

Table 35. BPE header - BPESMF29_BPEHDR DSECT (continued)

Name	Length	Type	Description
smf29bh_startStck	8	EBCDIC	1. STCK value of IMS batch or control region start for batch and control region-associated address spaces (CTL, DLI, DBRC, DEP) 2. STCK value at address space start for BPE-based address spaces
smf29bh_stck	8	EBCDIC	Current STCK when this record was built

Table 36 on page 225 describes the self-defining "triplet" section for subtype-2 records at offset SMF29STS from the start of the record. These triplets define the offsets, lengths, and number of sections that follow-on in the record.

Table 36. Self-defining triplets

Name	Length	Type	Description
SMF29SDS_TRIPLETS	2	binary	Number of triplets
*	2	binary	Reserved
SMF29SDS_OFFJRS	4	binary	Offset to Java runtime section
SMF29SDS_LENJRS	2	binary	Length of Java runtime section
SMF29SDS_NUMJRS	2	binary	Number of Java runtime sections
SMF29SDS_OFFGCS	4	binary	Offset to GC runtime section
SMF29SDS LENGCS	2	binary	Length of GC runtime section
SMF29SDS_NUMGCS	2	binary	Number of GC runtime sections
*	4	binary	Reserved

Table 37 on page 225 describes the Java runtime section for subtype-2 records that contains the usage information for a JVM. A subtype-2 record can contain more than one Java runtime section, and the number of Java runtime sections in the record is defined by the SMF29SDS_NUMJRS field.

Table 37. Fields of the Java runtime section

Name	Length	Type	Description
SMF29JRS_FDFLAGS	4	binary	Field flags The first flag byte denotes the version number of the JRS layout
*	4	binary	Reserved
SMF29JRS_NAME	80	EBCDIC	Formatted JVM name
SMF29JRS_STRTTME	8	binary	Start time in milliseconds

Name	Length	Type	Description
SMF29JRS_UPTIME	8	binary	Up time in milliseconds
SMF29JRS_GCPOLCY	40	EBCDIC	Garbage collection policy
SMF29JRS_PEAKTHRD	4	binary	Peak live thread count
SMF29JRS_CURRTHRD	4	binary	Current number of live threads

Table 38 on page 226 describes the garbage collector section for subtype-2 records that contains garbage collection information for a JVM. A subtype-2 record can contain more than one garbage collector section, and the number of garbage collector sections in the record is defined by the SMF29SDS_NUMGCS field.

Name	Length	Type	Description
SMF29GCS_FDFLAGS	4	binary	Field flags The first flag byte denotes the version number of the GCS layout.
*	4	binary	Reserved
SMF29GCS_NAME	40	EBCDIC	Garbage collector name
SMF29GCS_NUMCOLLS	8	binary	Total number of collections
SMF29GCS_COLLTME	8	binary	Approximate accumulated collection elapsed time
SMF29GCS_MEMFREED	8	binary	Cumulative total amount of memory freed in bytes
SMF29GCS_NUMCOMPCS	8	binary	Cumulative total number of compact that was performed
SMF29GCS_HEAPUSED	8	binary	Amount of heap memory used in bytes

STDENV shell scripting

You can use the STDENV DD statement to specify a z/OS shell script that defines the parameters, environment variables, and other elements needed to start the Java virtual machine (JVM) for an IMS dependent region. More options are available to you if you use a shell script rather than members of the PROCLIB data set.

When you use the STDENV DD statement, the IMS dependent region ignores PROCLIB members DFSJVMEV (specified in the ENVIRON= JCL startup parameter) and DFSJVMMS (specified in the JVMOPMAS= JCL startup parameter). To learn more about the STDENV DD statement, see [DD statements for IMS procedures \(System Definition\)](#).

To specify a shell script, code the STDENV DD statement with any of the following options. Data sets and concatenated files are read in the order that you list them:

- A single fully qualified data set specified with the **DSNAME/DSN** parameter.
- A single fully qualified file name specified with the **PATH** parameter.
- A concatenation of fully qualified data sets specified with the **DSNAME/DSN** parameter.
- A concatenation of fully qualified file names specified with the **PATH** parameter.
- A concatenation of fully qualified file names and fully qualified data sets.
- An in-stream data set specified as input using the ***** parameter.

Important: If you use both DSNAME and PATH, specify **FILEDATA=TEXT** and **PATHOPTS=ORDONLY** as part of the **PATH** parameter. An ABEND can occur if these values are not specified, preceded by the message IEC020I: UNIX FILE POSITIONING ERROR.

Shell script parameters

The following example shell scripts use z/OS shell (/bin/sh) syntax.

To export parameters as environment variables that the IMS dependent region can recognize, precede each parameter with the **export** keyword. For example, use the export keyword to specify the LIBPATH=, JLEOPT=, and the SMFINTERVAL= parameters:

```
...
LIBPATH=/lib:/usr/lib:"${JAVA_HOME}"/bin
...
export LIBPATH="$LIBPATH"
export JLEOPT=Y
export SMFINTERVAL=6000
```

Export the Java class path as an environment variable with the name CLASSPATH. Note that CLASSPATH length is limited to 150K characters when you use the STDENV DD statement:

```
export JAVA_HOME=/usr/lpp/java/java180/J8.0
export CLASSPATH="${JAVA_HOME}"/lib:...
```

Export other IBM JVM options as an environment variable with the name IBM_JAVA_OPTIONS:

```
IJO="-Xms256m"
IJO="$IJO -Xmx1024m"
export IBM_JAVA_OPTIONS="$IJO"
```

When you use a shell script, you can specify the following additional parameters.

JZOS_OUTPUT_ENCODING=codepage specifies the code page to use for stdout and stderr encoding:

```
export JZOS_OUTPUT_ENCODING=Cp1047
```

JZOS_ENABLE_OUTPUT_TRANSCODING=true | false specifies whether to use the code page that is specified in JZOS_OUTPUT_ENCODING for stdout and stderr encoding. The default value is true. If the value is set to false, the specified code page is ignored and raw bytes are written to stdout and stderr:

```
export JZOS_ENABLE_OUTPUT_TRANSCODING=false
```

Good scripting practices

Use the following practices when creating, maintaining, and validating shell scripts:

- Avoid using in-stream data sets, which can make script syntax validation difficult.
- After making script changes, validate the revised script syntax immediately to identify potential errors.
- Make incremental changes and validate often to identify and isolate potential errors.
- Keep and organize your shell scripts in data sets or UNIX System Services files.

- Avoid long running loops when possible.



Attention: If the dependent region stalls, IMS issues the status code WAIT-INIT-INPROG. To stop the stalled operation, issue the command **/STO REGION ABDUMP FORCE**. Learn more at [STOP REGION command \(Commands\)](#).

A sample shell script

```
export JAVA_HOME=/usr/lpp/java/java180/J8.0
LP=/tmp
LP="$LP":$JAVA_HOME/bin/j9vm/
LP="$LP":$JAVA_HOME/bin/
LP="$LP":$JAVA_HOME/lib/
LP="$LP":$JAVA_HOME/lib/compressedrefs/
LP="$LP":$JAVA_HOME/lib/
LP="$LP":/usr/lpp/ims/ims15/imsjava/lib/
export LIBPATH="$LP":
CP=/tmp
CP="$CP":$JAVA_HOME/
CP="$CP":$JAVA_HOME/lib/
CP="$CP":$JAVA_HOME/lib/ext
CP="$CP":/tmp/udbtest-0.0.1.jar
CP="$CP":/usr/lpp/ims/ims15/imsjava/imsudb.jar
export CLASSPATH="$CP":
IJO="-Xms256m"
IJO="$IJO -Xmx512m"
IJO="$IJO -Djzos.logging=E"
IJO="$IJO -Djzos.merge.sysout=false"
# Sample parameters from DFSJVMEV
export IBM_JAVA_OPTIONS="$IJO "
export CANCEL_PGM=N
export JLEOPT=N
#export SMFINTERVAL=6000
```

STDENV script validation

IMS dependent region initialization can stall if a script contains syntax errors or produces long running loops. Syntax errors are often caused by a missing text character, such as a double quotation mark, single quotation mark, square bracket, or curly brace (" , ' , [], { }, ...). To prevent stalls, validate shell script syntax as you make changes and before you specify the script in the dependent region.

To validate your scripts, first verify that your user ID is configured to access a UNIX System Services shell (/bin/sh or /bin/tcsh). To learn more about shell access, see [z/OS: Accessing the shells — the choices](#).

Next, use one of the following options to obtain shell access. Using an SSH session or the OSHELL command at the TSO/E READY prompt can yield a better user experience than OMVS because they provide more space to enter commands.

- Establish an SSH session between your computer and the target system by using a command line terminal and the command: **ssh userID@hostname**
- At the TSO/E READY prompt or from the ISPF Command Shell panel (ISRTSO), use OSHELL plus the UNIX System Services command you want to run.
- Use the OMVS command from the ISPF Command Shell panel (ISRTSO) or at the TSO/E READY prompt to get a 3270 terminal interface to the z/OS shell.

With a connection established, use the UNIX System Services commands **cat**, **|** (pipe), and **sh** to validate the contents of your STDENV shell scripts.

- Use the **cat** command to read the contents of files and fully qualified data set members.
- Use the **|** (pipe) command to pass the output of **cat** as input to the z/OS shell (/bin/sh) for processing.
- When starting the shell, use the **-x** option to make the shell print commands and arguments as they run.

As an example, enter the following commands to pass the contents of YOURHLQ.STDENV.CONFIGS(STDENV00) as input to the shell script, and to print commands and arguments as they run:

```
cat "'YOURHLQ.STDENV.CONFIGS(STDENV00)'" | /bin/sh -x
```

Use the same technique to validate STDENV scripts. For example, in the following script fragment, the data set member STDENV00 contains a missing closing curly brace in the second LP= statement. This error makes the script is invalid because "\${JAVA_HOME}" is supposed to be "\${JAVA_HOME}".

```
...
export JAVA_HOME=/usr/lpp/java/java180/J8.0
LP=/tmp
LP="$LP":"${JAVA_HOME}/bin/j9vm/
...
```

To validate the script, print the commands and their arguments as they run, pipe the contents of the STDENV00 member into the z/OS shell, and specify the **-x** option. This example uses an SSH session. The shell prompt is signified by the **#** character:

```
# cat "'YOURHLQ.STDENV.CONFIGS(STDENV00)'" | /bin/sh -x
```

The command produces the following output:

```
...
+ export JAVA_HOME=/usr/lpp/java/java180/J8.0
+ LP=/tmp
FSUM7728 bad ${} modifier
```

To identify and isolate errors, compare the original script to the output. In this case, the line in the script that has the error is replaced with the message `FSUM7728 bad ${} modifier`. To validate the script, correct the error and rerun the script using the same **cat**, **|**, and **-x** technique. Repeat until the entire script runs successfully.

Tip: Using the **-x** option when starting the shell produces the same behavior as using the **set -x** command inside a shell script. To learn more, see [set - Set or unset command options and positional parameters](#).

How to use the commands **cat**, **|** (pipe), and **sh** with data sets and UNIX System Services files

The following examples describe how to validate STDENV scripts that reside in single or multiple data sets, single or multiple Unix System Services files, or a combination of data sets and files. Each example shows how to perform the same action using the SSH, OSHELL, and OMVS shell access options. Unless specified otherwise, you run each command by pressing the Enter (or Return) key on your computer keyboard.

Example 1 - Single data set

In this example, the STDENV shell script is in a single fully qualified data set member:

```
YOURHLQ.STDENV.CONFIGS(STDENV00)
```

To validate the STDENV shell script, run one of the following commands.

Using an SSH session:

```
# cat "'YOURHLQ.STDENV.CONFIGS(STDENV00)'" | /bin/sh -x
```

Using the OSHELL command at the TSO/E READY prompt:

```
READY OSHELL cat "'YOURHLQ.STDENV.CONFIGS(STDENV00)'" | /bin/sh -x
```

Using an OMVS session:

```
====> cat "'/YOURHLQ.STDENV.CONFIGS(STDENV00)'" | /bin/sh -x
```

Example 2 - Multiple data sets

In this example, the STDENV shell script spans across multiple data set members:

```
"YOURHLQ.STDENV.CONFIGS(STDENV00)"  
"YOURHLQ.STDENV.CONFIGS(STDENV01)"
```

To validate the STDENV shell script, run one of the following commands. Notice that the fully qualified data set members are separated by a blank.

Using an SSH session:

```
# cat "'/YOURHLQ.STDENV.CONFIGS(STDENV00)'"  
"'/YOURHLQ.STDENV.CONFIGS(STDENV01)'" | /bin/sh -x
```

Using the OSHELL command at the TSO/E READY prompt:

```
READY OSHELL cat "'/YOURHLQ.STDENV.CONFIGS(STDENV00)'"  
"'/YOURHLQ.STDENV.CONFIGS(STDENV01)'" | /bin/sh -x
```

Using an OMVS session (note that you cannot easily copy or paste, and that the size of the command on each line is limited):

```
====> cat "'/YOURHLQ.STDENV.CONFIGS(STDENV00)'"  
"'/YOURHLQ.STDENV.CONFIGS(STDENV01)'" | /bin/sh -x
```

If the command is too long to fit in the OMVS session command prompt, you can use the command continuation character `\` (backslash) to continue the command on the next line. After each use of the `\` character, press Enter.

```
====> cat "'/YOURHLQ.STDENV.CONFIGS(STDENV00)'" \  
====> "'/YOURHLQ.STDENV.CONFIGS(STDENV01)'" \  
====> | /bin/sh -x
```

Example 3 - Single file in UNIX System Services

In this example, the STDENV shell script is in a single file in UNIX System Services.

```
" /yourPath/STDENV-configs/STDENV00.cfg"
```

To validate the STDENV shell script, run one of the following commands.

Using an SSH session:

```
# cat /yourPath/STDENV-configs/STDENV00.cfg | /bin/sh -x
```

Using the OSHELL command at the TSO/E READY prompt:

```
READY OSHELL cat /yourPath/STDENV-configs/STDENV00.cfg | /bin/sh -x
```

Using an OMVS session:

```
====> cat /yourPath/STDENV-configs/STDENV00.cfg | /bin/sh -x
```

Example 4 - Multiple files in UNIX System Services

In this example, the STDENV shell script resides in multiple files in UNIX System Services.

```
" /yourPath/STDENV-configs/STDENV00.cfg"  
" /yourPath/STDENV-configs/STDENV01.cfg"
```

To validate the STDENV shell script, run one of the following commands. Notice that the file paths are separated by a blank.

Using an SSH session:

```
# cat /yourPath/STDENV-configs/STDENV00.cfg /yourPath/STDENV-configs/STDENV01.cfg | /bin/sh -x
```

Using the OSHELL command at the TSO/E READY prompt:

```
READY OSHELL cat /yourPath/STDENV-configs/STDENV00.cfg  
/yourPath/STDENV-configs/STDENV01.cfg | /bin/sh -x
```

Using an OMVS session:

```
====> cat /yourPath/STDENV-configs/STDENV00.cfg  
/yourPath/STDENV-configs/STDENV01.cfg | /bin/sh -x
```

If the command is too long to fit in the OMVS session command prompt, you can use the command continuation character `\` (backslash) to continue the command on the next line. After each use of the `\` character, press Enter.

```
====> cat /yourPath/STDENV-configs/STDENV00.cfg \  
====> /yourPath/STDENV-configs/STDENV01.cfg \  
====> | /bin/sh -x
```

Example 5 - Data set and UNIX System Services file

In this example, the STDENV shell script resides in a file in UNIX System Services and in a data set member.

```
" /yourPath/STDENV-configs/STDENV00.cfg"  
"YOURHLQ.STDENV.CONFIGS(STDENV01)"
```

To validate the STDENV shell script, run one of the following commands. Notice that the file paths are separated by a blank.

Using an SSH session:

```
# cat /yourPath/STDENV-configs/STDENV00.cfg  
"//'YOURHLQ.STDENV.CONFIGS(STDENV01)'" | /bin/sh -x
```

Using the OSHELL command at the TSO/E READY prompt:

```
READY OSHELL cat /yourPath/STDENV-configs/STDENV00.cfg  
"//'YOURHLQ.STDENV.CONFIGS(STDENV01)'" | /bin/sh -x
```

Using an OMVS session:

```
====> cat /yourPath/STDENV-configs/STDENV00.cfg  
"//'YOURHLQ.STDENV.CONFIGS(STDENV01)'" | /bin/sh -x
```

If the command is too long to fit in the OMVS session command prompt, you can use the command continuation character `\` (backslash) to continue the command on the next line. After each use of the `\` character, press Enter.

```
====> cat /yourPath/STDENV-configs/STDENV00.cfg \  
====> "//'YOURHLQ.STDENV.CONFIGS(STDENV01)'" \  
====> | /bin/sh -x
```

Error message examples

The following examples show common syntax errors and their related expected error messages. Note that your shell might display error messages with colons (: :) instead of square brackets ([]) or curly braces ({}):

```
FSUM7728 bad $:: modifier
```

Example 1 - A missing double quotation mark

STDENV00 is missing a double quotation mark ":

```
export IBM_JAVA_OPTIONS="$IJO
```

or

```
export IBM_JAVA_OPTIONS=$IJO"
```

The resulting error message is as follows. Notice that the error message reports a missing **closing** quotation mark regardless of where the element is missing in the character string:

```
FSUM7729 missing closing ""
```

Example 2 - A missing single quotation mark

STDENV00 is missing a single quotation mark ':

```
APP_HOME='/tmp/
```

or

```
APP_HOME=/tmp/'
```

As with the missing double quotation mark, the resulting message identifies the error as a missing **closing** single quotation mark regardless of where the single quotation mark should appear in proper syntax:

```
FSUM7729 missing closing ''
```

Example 3 - A missing opening or closing square bracket

STDENV00 contains a missing open square bracket [:

```
if [ -t "$fd" || -p /dev/stdin ] ]
```

Though the error is caused by a missing open bracket, notice that the resulting error message reports a different syntax problem:

```
FSUM7332 syntax error: got ]], expecting then
```

STDENV00 contains a missing close square bracket]:

```
if [[ -t "$fd" || -p /dev/stdin ]
```

The resulting error message is as follows. Notice that the reported error is different from the actual cause:

```
FSUM7332 syntax error: got EOF, expecting ]]
```

Example 4 - A missing opening or closing curly brace



Attention: A missing opening curly brace may not be detected as an error. This can result in the closing curly brace being treated as part of the statement. To minimize programming defects, exercise care when writing and reviewing script statements that include curly braces.

STDENV00 is missing a closing curly brace **}**:

```
APP_HOME="${JAVA_HOME}"
```

The resulting error message is as follows:

```
FSUM7728 bad ${} modifier
```

Chapter 7. Provision IMS resources with z/OSMF

You can quickly provision IMS resources, such as IMS DB/TM systems or Fast Path DEDB databases, in z/OS by using the IBM z/OS Management Facility (z/OSMF) workflows that are available for download from GitHub.

IMS provides workflows for IMS resources via GitHub. After you download the workflows and make them available to z/OSMF in your z/OS environment, you can easily provision IMS resources.

If the Cloud Provisioning feature of z/OSMF is enabled, you can create templates from the workflows that can be used to provision IMS resources in IBM Z® environments in a cloud.

The .zip file for each resource type includes the readme file, and the XML and properties files that make up a workflow.

You can download the .zip file for each available resource workflow from GitHub at [IMS-zOSMF-Workflows](#).

You can find the documentation for z/OSMF z/OSMF and the Cloud Provisioning feature at [z/OS: IBM z/OS Management Facility](#).

Provision an IMS DB/TM system

You can provision an IMS DB/TM system by using the IBM z/OS Management Facility workflow that IMS provides via GitHub.

About this task

With the provisioning workflow, IMS also provides a workflow to deprovision an IMS DB/TM system.

A workflow consists of several XML files and a properties file.

Procedure

1. From the **IMS-zOSMF-Workflows** repository in GitHub, download the compressed folder (.zip file) that contains the workflows you need and extract the contents to a local directory.
2. Review the readme that is included in the .zip file for details about the workflows.
3. Transfer the extracted files to a data set or directory on z/OS where they are available to your z/OSMF instance.
4. From the z/OSMF welcome page, select **Workflows** from the navigation pane on the left.
5. Select **Create a workflow** and specify the location of the workflow file and other initial information, such as your user name.
6. After the steps of the workflow are displayed in the z/OSMF interface, you can begin completing each step by providing the information that each step requires.

Some steps require you to begin by expanding the step and starting with the substeps.

What to do next

After you complete the steps and an IMS system is provisioned, run the IMS Installation Verification Program (IVP) to finish tailoring the system to your needs.

Related reference

[IMS-zOSMF-Workflows](#)

Related information

[z/OS: IBM z/OS Management Facility](#)

Provision Fast Path DEDB databases

You can provision an IMS Fast Path DEDB database by using the IBM z/OS Management Facility workflow that IMS provides via GitHub.

About this task

With the provisioning workflow, IMS also provides a workflow to deprovision a DEDB database.

A workflow consists of several XML files and a properties file.

Procedure

1. From the **IMS-zOSMF-Workflows** repository in GitHub, download the compressed folder (.zip file) that contains the workflows you need and extract the contents to a local directory.
2. Review the readme that is included in the .zip file for details about the workflows.
3. Transfer the extracted files to a data set or directory on z/OS where they are available to your z/OSMF instance.
4. From the z/OSMF welcome page, select **Workflows** from the navigation pane on the left.
5. Select **Create a workflow** and specify the location of the workflow file and other initial information, such as your user name.
6. After the steps of the workflow are displayed in the z/OSMF interface, you can begin completing each step by providing the information that each step requires.

Some steps require you to begin by expanding the step and starting with the substeps.

Related reference

[IMS-zOSMF-Workflows](#)

Related information

[z/OS: IBM z/OS Management Facility](#)

Chapter 8. CQS definition and tailoring

The tasks for defining and tailoring the Common Queue Server (CQS) involve working with macros, procedures, and other system-oriented information.

This topic contains Product-sensitive Programming Interface information.

CQS's support of multiple clients

A single CQS address space can support as many as 32 different clients that are on the same z/OS image. One CQS address space can support multiple clients. Examples of clients are IMS and RM.

As many as 32 different clients on the same z/OS image can connect to coupling facility structures through a single CQS by using the CQSCONN request. For example, as many as 32 different IMS control regions can specify the same CQS=xxx parameter in the DFSSQxx member of the IMS PROCLIB data set. IMS starts the CQS address space if it is not currently active. If CQS is already active, IMS registers with the active CQS address space and does not start an additional CQS address space. Be sure that not more than 32 IMS systems or RMs specify the same CQS.

Defining structure size for CQS connections

Use the INITSIZE and SIZE parameters of the z/OS CFRM policy to define the size of the CQS structures.

The size of the structures to which CQS connects is defined in the CFRM policy by defining the INITSIZE (initial size of the structure) and SIZE (maximum size of the structure) parameters. If enough free space does not exist for this INITSIZE value, the size of the structure becomes that of the available space in the coupling facility.

To determine what structure size to define in the CFRM policy, you can use the System z® Coupling Facility Structure Sizer Tool (CFSizer). CFSizer is a web-based application that calculates the structure size based on the input data you provide. CFSizer is available at [System z Coupling Facility Structure Sizer Tool \(CFSizer\) web page](#).

You can use the z/OS structure alter process to change the structure size or to redistribute the objects within the structure after it has been defined. For information, see [Using structure alter for CQS \(System Administration\)](#).

Calculating resource structure entry and element values to maximize storage

Several different resources can be stored in the resource structure. It is important to create a resource structure of sufficient size to accommodate these resources. Use the recommendations in this topic to calculate a resource structure of appropriate size.

An IMS system with a defined resource structure stores transaction names in the resource structure. Additional resources can be stored in the resource structure depending on the IMS functions that you enable, as shown in the following table:

Table 39. Resources stored in the resource structure

IMS function that is enabled	Resources that are stored in the resource structure	Comments
IMS sysplex terminal management	<ul style="list-style-type: none"> • APPC descriptor • node name • remote and local system identifications / names in a Multiple Systems Coupling (MSC) environment • user ID • CPIC transaction • user information 	Resources are not stored if sysplex terminal management is disabled by defining STM=NO on the DFSDCxxx PROCLIB data set member.
IMS global online change	Global online change stores a resource on the resource structure to manage the global online change process.	Resources are not stored unless global online change is enabled by specifying OLC=GLOBAL on the DFSCGxxx PROCLIB data set member.
IMS global status for areas, databases, and transactions	<ul style="list-style-type: none"> • global area information • global database information • global transaction information 	Resources are not stored unless global status for areas, databases, and transactions is enabled by using either: <ul style="list-style-type: none"> • The COMMON_SERVICE_LAYER section of the DFSDFxxx PROCLIB member data set and specifying GSTSDB=(Y) to enable global database status, GSTSAREA=(Y) to enable global area status, and GSTSTRAN=(Y) to enable global transaction status. • The DFSCGxxx PROCLIB data set member.
Serialized program management	serialized program names	Resources are not stored unless serialized program management is enabled by specifying the GBL_SERIAL_PGM parameter in the DFSCGxxx member of the IMS PROCLIB data set.

Each resource is stored on the resource structure using a 128-byte entry, and either zero, one, or more 512-byte data elements. The 128-byte entry contains 64 bytes for z/OS control information, and 64 bytes for user data in an adjunct area. Both IMS and CQS use a portion of the 512-byte data element as a prefix. The remaining bytes are available for client data.

Use the entry-to-element ratio when allocating the resource structure to reserve portions for entries and data elements. The more accurate the ratio is for actual resources stored on the resource structure, the less storage is wasted. The number of entries is equal to the number of resources. The number of data elements depends on the number of resources for each resource type.

The information and formulas in the following table can help you determine the ENTRY and ELEMENT values to define in the CQSSGxxx PROCLIB data set member. For each resource type used by your installation, add the entry value to the entry sum and add the element value to the element sum. To calculate the ENTRY value, locate the resource types used by your installation in the table and add the

entry value for the resource types to the system resource value. To calculate the ELEMENT value, locate the resource types used by your installation and add the element value for the resource types to the system resource value.

For example, if you do not use sysplex terminal management (STM=NO), the ENTRY value is the number of transactions plus 8 (system resources), and the ELEMENT value is 14 (system resources).

Resource type	System definition status, if applicable	Entry value	Element value	Meaning
APPC descriptor	STM=NO	0	0	Unique APPC descriptors in the IMSplex
	STM=YES	Number of descriptors	0, if the number of IMS systems is less than 3. If the number of IMS systems is greater than 2, the count is (the number of IMS systems) multiplied by (the number of IMS systems - 2) divided by 29 (rounded up).	
Area	GSTSAREA=(N)	0	0	Area with global status. This can be the number of Fast Path areas you plan to use to maintain global status, or the total number of areas.
	GSTSAREA=(Y)	Number of Fast Path areas		
Database	GSTSDB=(N)	0	0	Databases with global status. This can be the number of databases that you plan to use to maintain global status, or the total number of databases.
	GSTSDB=(Y)	Number of databases		
Global Online Change	OLC=LOCAL	0	0	Global Online Change in progress.
	OLC=GLOBAL	1	1	
Lterm	STM=NO	0		System generated and dynamic logical terminals.
	STM=YES	Number of LTERMs ¹	0	
MSName	STM=NO	0	0	Unique system-generated MSNames in the IMSplex.
Node	STM=NO	0	0	System generated and dynamic nodes
	STM=YES	Number of VTAM nodes ¹	Number of ISC nodes with multiple parallel sessions multiplied by (the node's maximum parallel sessions - 1) divided by 29, rounded up.	

Table 40. Formulas for calculating resource structure entry and element values (continued)

Resource type	System definition status, if applicable	Entry value	Element value	Meaning
Serial program		Number of serial programs	0	System generated and dynamic programs that are defined with a scheduling type of SERIAL
System resources		$8 + (x \text{ multiplied by } 3) + (y) + (z) + q^3$	$14 + (x \text{ multiplied by } 2)^4$	IMS, CQS, and RM resources x The number of IMS systems y The number of CQs z The number of RMs q The number of structures
Transactions		Number of transactions	0	System generated, non-CPIC transactions
CPIC transactions	STM=NO	0	0	CPIC transactions invoked by APPC
	STM=YES	Number of CPIC transactions	0, if the number of IMS systems is less than 3. If the number of IMS systems is greater than 2, the value is the number of CPIC transactions multiplied by (the number of IMS systems - 1) divided by 29, rounded up.	
User ID	STM=NO	0	0	Maximum number of user IDs signed on.
	STM=YES	Number of user IDs if SGN is not either G, M, or Z.		
User	STM=NO	0	0	Dynamic users and unique static ISC subpools
	STM=YES	Number of users ¹	Number of users ²	
User - static node	STM=NO	0	0	Unique static single-session users
	STM=YES	Number of static users ¹	Number of static users ²	

Table 40. Formulas for calculating resource structure entry and element values (continued)

Resource type	System definition status, if applicable	Entry value	Element value	Meaning
Note:				
<p>1. The entry value is the maximum number of LTERMs or nodes where:</p> <ul style="list-style-type: none"> • the assigned node is logged on. • the assigned node has significant status • the assigned user is signed on. • the LTERMs have significant status. 				
<p>2. The element value is normally one per user or static node user, but it is greater than one if either the number of LTERMs is excessive, the number of held conversations is excessive, or both. Each user or static node user resource stores a minimum of the sum of the following values:</p>				
<p>176 bytes in a data element + 16 bytes for each associated LTERM + 52 bytes for each held conversation + 196 bytes if a Fast Path transaction is in progress</p>				
<p>If the number of bytes exceeds the amount available for client data in a data element, more data elements are used.</p>				
<p>3. The IMS, RM, and CQS system resource entries include:</p> <ul style="list-style-type: none"> • CQSGLOBAL • CQSGLOBALCONN • CQSLOCALcqsid (one per CQS) • CQSRECOVER (one per structure type MSGQ, EMHQ, and resource) • CSLRGBL • CSLRLrmid (one per RM) • CSLRMPRCprocessid (one per IMSplex-wide process) • CSLRRTYP • DFSGBLPLXPN • DFSGBLSYS • DFSSTMGBL • DFSSTMLimsid (one per IMS) • Primary master terminal (one per IMS) • Secondary master terminal (one per IMS) 				
<p>4. The IMS, RM, and CQS system resource elements include:</p> <ul style="list-style-type: none"> • CQSGLOBAL • CQSGLOBALCONN • CSLRGBL • CSLRMPRCprocessid (one per IMSplex-wide process) • CSLRRTYP (9) • DFSGBLSYS • Primary master terminal (one per IMS) • Secondary master terminal (one per IMS) 				

If the entry or element value exceeds the maximum value of 65 535, reduce the entry or element value to a value that is less than 65 535. If the value of the elements divided by the entries is greater than 120, reduce the values so that the value of the elements divided by the entries is less than or equal to 120. For example, if your calculation results in a ratio of 131 070 entries to 65 535 elements, this can be reduced to a ratio of two entries to one element, because 131 070 divided by 65 535 is equivalent to 2 divided by 1. If you want to allocate a structure large enough to support your maximum number of IMS systems, RMs, CQSs, and resources, use the maximum values in the table above to calculate the values from the formula.

Make sure that your structure's number of entries and elements is greater than the calculated entry and element values prior to activating STM. If it is not, you can use the z/OS SETXCF command to make your structure bigger.

Preparing to start the CQS address space

Before you can start the Common Queue Server (CQS) address space, you must define CQS parameters, and you must create and activate the necessary z/OS policies.

Before you begin

Because they are a part of the defined IMS system, CQS and Base Primitive Environment (BPE) are automatically linked into IMS.SDFSRESL when you run the JCLIN job stream.

You must define CQS parameters before starting the CQS address space. Define the parameters using either of the following:

- CQS initialization parameters member of the IMS PROCLIB data set (CQSIPxxx)
- CQS startup procedure (CQSINIT0 or BPEINI00)

Procedure

1. Create a coupling facility resource management (CFRM) policy that defines the structures to which you want CQS to connect. The CFRM policy specifies the name, size, attributes, and location that the structure is to be assigned when it is allocated.
 2. Define the following z/OS policies:
 - Sysplex failure management (SFM) policy
 - System logger (LOGR) policy

Note: In the LOGR policy, specify the MAXBUFSIZE parameter as 65272 bytes to ensure that the system logger can write the largest possible log record that is written by CQS.
 - Automatic restart management (ARM) policy
3. Activate the CFRM policy using the following command:

```
SETXCF START,POLICY,TYPE=CFRM,POLNAME=CONFIG01
```

The structure is allocated when the first CQS connects to it.

4. If you are using the SFM policy, activate it using the following command:

```
SETXCF START,POLICY,TYPE=SFM,POLNAME=SFMPOL
```

5. Create the CQS and BPE members of the IMS PROCLIB data set.
6. Define all CQS execution data sets.
7. Customize your CQS environment; determine which exits you want to use and then write the exits, which can include the following:

- CQS initialization-termination user-supplied exit routine
- CQS client connection user-supplied exit routine
- Queue overflow user-supplied exit routine for CQS

CQS structure statistics user-supplied exit routine
CQS structure event user-supplied exit routine
CQS statistics available through the BPE statistics user exit

8. Authorize connections to CQS structures.
9. Update the z/OS program properties table.
10. Plan security.

Related reference

[“CQSIPxxx member of the IMS PROCLIB data set” on page 692](#)

Use the CQSIPxxx member of the IMS PROCLIB data set to specify parameters that are related to initialization of the CQS address space. You can use CQS execution parameters to override certain parameters within CQSIPxxx.

Chapter 9. CSL definition and tailoring

You can define the Common Service Layer using several IMS PROCLIB data sets; after they are defined, they should be started in a specific sequence.

The IMS Common Service Layer (CSL) comprises several address spaces that provide system services to IMS. These address spaces include:

- Open Database Manager
- Operations Manager
- Resource Manager
- Structured Call Interface

Related tasks

[“Defining IMS-to-IMS TCP/IP connections for MSC” on page 312](#)

Defining IMS-to-IMS TCP/IP connections for MSC requires defining MSC and IMS Connect and enabling a minimally configured IMSplex at each end of an MSC link.

Defining the Common Service Layer using IMS PROCLIB data set members

The Common Service Layer (CSL) can be defined and tailored using several different IMS PROCLIB data set members.

The following IMS PROCLIB data set members can be used to define settings and values for the Common Service Layer (CSL) and its managers: Open Database Manager, Operations Manager, Resource Manager, and Structured Call Interface. The uses described here are specifically for the CSL.

BPECFGxx

The CSL ODBM, OM, RM, and SCI all use the Base Primitive Environment (BPE). Use the BPE configuration member of the IMS PROCLIB data set to configure the BPE execution environment parameters for each CSL manager. Each CSL manager can have its own BPE configuration and user exit definition members, or they can share common members.

CQSIPxxx

Use the IMSPLEX() and NAME= parameters on this IMS PROCLIB data set member to define the IMSplex name.

CQSSGxxx

Use the RSRCSTRUCTURE() parameter on this IMS PROCLIB data set member to define a resource structure for the Resource Manager.

CSLDCxxx

Use the CSLDCxxx IMS PROCLIB data set member to configure the ODBM data store connections to IMS systems.

CSLDIxxx

Use the CSLDIxxx IMS PROCLIB data set member to specify parameters that initialize the ODBM address space. Certain parameters within CSLDIxxx can be overridden with the ODBM execution parameters.

CSLOIxxx

Use the CSLOIxxx IMS PROCLIB data set member to specify parameters that initialize the OM address space. Certain parameters within CSLOIxxx can be overridden with the OM execution parameters.

CSLRIxxx

Use the CSLRIxxx IMS PROCLIB data set member to specify parameters that initialize RM. Some parameters within CSLRIxxx can be overridden with RM execution parameters.

CSLSIxxx

Use the CSLSIxxx IMS PROCLIB data set member to specify parameters related to initialization of the SCI address space. Certain parameters within CSLSIxxx can be overridden using SCI execution parameters.

DFSCGxxx

All the parameters on this IMS PROCLIB data set member specify parameters related to the Common Service Layer (CSL), including the Operations Manager (OM), the Resource Manager (RM), and the Structured Call Interface (SCI).

DFSDCxxx

Use the AOS= parameter on this IMS PROCLIB data set member to enable IMSplex users to execute transactions that are originated by APPC or OTMA on a back-end system. Use the SRMDEF= parameter to globally save the status of a resource every time the significant status changes. Use the STM= parameter to have IMS the Resource Manager resource structure to manage TM resources.

DFSDFxxx

Specify CSL parameters in the CSL section of the DFSDFxxx IMS PROCLIB data set member or on the DFSCGxxx IMS PROCLIB data set member. All parameters that are valid in the DFSCGxxx member of the IMS PROCLIB data set are valid in the DFSDFxxx member of the IMS PROCLIB data set. Either the DFSCGxxx IMS PROCLIB data set member or the CSL section in the DFSDFxxx IMS PROCLIB data set member initiate the CSL. If you specify the CSL parameters on both IMS PROCLIB data set members, the values in DFSCGxxx take precedence. You should specify OM command security instead of IMS security. All IMSplex members that are in the same IMSplex group sharing databases, message queues, or both, must specify the same values except OLC=, which specifies either LOCAL or GLOBAL.

DFSPBxxx

Use the CSLG= parameter to specify a three-character suffix for the DFSCGxxx member of the IMS PROCLIB data set.

DFSVMxxx

Use the OCMD= and CSLT= parameters on this IMS PROCLIB data set member to activate traces related to IMSplex activity.

EXITDEF

Each of the CSL managers use BPE services to define and manage calls to user exit routines. You can externally specify the user exit routine modules to be called for a particular exit routine type using EXITDEF statements in BPE user exit members of the IMS PROCLIB data set.

Sample ODBM user exit list member of the IMS PROCLIB data set

A sample ODBM BPE user exit list member of the IMS PROCLIB data set is shown in the following example.

```
*****
* ODBM USER EXIT LIST PROCLIB MEMBER *
*****

#-----#
# DEFINE 1 ODBM INIT/TERM USER EXIT: ZDINTM00 #
#-----#
EXITDEF (TYPE=INITTERM, EXITS=(ZDINTM00), COMP=ODBM)

#-----#
# DEFINE 1 ODBM INPUT USER EXIT: ZINPUT00 #
# WITH AN ABEND LIMIT OF 8. #
#-----#
EXITDEF (TYPE=INPUT, EXITS=(ZINPUT00), ABLIM=8, COMP=ODBM)

#-----#
# DEFINE 1 ODBM OUTPUT USER EXIT: ZOUTPUT0 #
#-----#
EXITDEF (TYPE=OUTPUT, EXITS=(ZOUTPUT0), COMP=ODBM)
```

Sample OM BPE user exit list member of the IMS PROCLIB data set

In the sample OM BPE user exit list member of the IMS PROCLIB data set shown below, an OM input user exit, ZINPUT00, is defined with an abend limit of 8.

```
*****
* OM USER EXIT LIST PROCLIB MEMBER *
*****

#-----#
# DEFINE 1 OM INPUT USER EXIT: ZINPUT00 #
# WITH AN ABEND LIMIT OF 8. #
#-----#
EXITDEF (TYPE=INPUT,EXITS=(ZINPUT00),ABLIM=8,COMP=OM)
```

Sample RM BPE user exit list member of the IMS PROCLIB data set

In the sample RM BPE user exit list member of the IMS PROCLIB data set shown below, an RM client connection user exit and initialization-termination exit are defined. The client connection user exit has an abend limit of 8.

```
*****
* RM USER EXIT LIST PROCLIB MEMBER *
*****

#-----#
# DEFINE 1 RM CLIENT CONNECTION USER EXIT: ZRCLNCN0 #
# WITH AN ABEND LIMIT OF 8. #
#-----#
EXITDEF (TYPE=CLNTCONN,EXITS=(ZRCLNCN0),ABLIM=8,COMP=RM)

#-----#
# DEFINE 1 RM INIT/TERM USER EXIT: ZRINTM00 #
#-----#
EXITDEF (TYPE=INITTERM,EXITS=(ZRINTM00),COMP=RM)
```

Sample SCI BPE user exit list member of the IMS PROCLIB data set

In the sample SCI BPE user exit list member of the IMS PROCLIB data set shown below, an SCI initialization-termination user exit is defined.

```
*****
* SCI USER EXIT LIST PROCLIB MEMBER *
*****
#-----#
# DEFINE 1 SCI INIT/TERM USER EXIT: ZSINTM00 #
#-----#
EXITDEF (TYPE=INITTERM,EXITS=(ZSINTM00),COMP=SCI)
```

Sequence for starting CSL address spaces

The CSL comprises several address spaces, some of which need to be started either before or after other CSL and IMS address spaces.

The recommended starting sequence for the CSL is:

1. Start the SCI address space and IRLM.
2. Start the OM address space and, if your IMSplex includes queue structures and resource structures, CQS.
3. If needed, start the Repository Server (RS) address space.
4. If needed, start the RM address space, which manages resources that are shared by multiple IMS systems in an IMSplex.
5. Start the IMS control region. The IMS control region then automatically initiates the DBRC address space.

6. If needed, start any other optional IMSplex components, such as ODBM (which routes database access requests to IMS DB in DB/TM and DBCTL configurations) and IMS Connect.

If CQS is started before the SCI address space, message CQS0001E is issued. See *IMS Version 15.4 Messages and Codes, Volume 2: Non-DFS Messages*.

Chapter 10. IMS catalog definition and tailoring

The IMS catalog is a system database that, when enabled, stores the definitions of your databases and program specification blocks (PSBs), as well as other metadata about your databases and application programs.

The IMS catalog is optional; however, certain IMS functionality, such as database versioning or the management of runtime application control blocks by IMS, requires the IMS catalog.

Because the IMS catalog is a system database, IMS performs many of the tasks required to define the catalog for you. If you need greater control, you can perform some of these tasks yourself.

The following topics provide the information you need to define and enable the IMS catalog.

Setting up the IMS catalog

The following steps provide a high-level overview of setting up the IMS catalog for the first time.

About this task

The following steps are for a single IMS catalog database in a single IMS system.

Note: The IMS Installation Verification Program (IVP) provides sample jobs and tasks that demonstrate how to allocate, load, and configure a simple IMS catalog. See the online help for IV_O254T: Introduction to the IMS catalog.

Procedure

1. Install the DBDs and PSBs for the IMS catalog from the IMS.SDFSRESL data set to the IMS.DBDLIB and IMS.PSBLIB data sets.

The catalog DBDs are called DFSCD000 and DFSCX000. The PSBs are called DFSCPL00, DFSCP000, DFSCP001, DFSCP002, and DFSCP003. These names are reserved and cannot be changed or used for other resources.

2. Run the ACB Maintenance utility to generate the ACB for the IMS catalog.

For example, JCL for the ACB Maintenance utility, see Install the DBDs and PSBs for the IMS catalog.

3. Activate the ACB library that contains the IMS catalog ACB.

4. If you are enabling the IMS management of ACBs, configure the Common Service Layer (CSL), including the Operations Manager (OM), the Structured Call Interface (SCI), and, if multiple IMS systems will share the IMS catalog, the Resource Manager (RM).

OM and SCI are required to support the activation of ACBs in online IMS systems.

If multiple IMS systems will share the catalog, specify ACBSHR=Y in the CSL configuration member in the PROCLIB data set.

If multiple IMS systems that will share the catalog are on different systems in a sysplex data sharing environment, you must specify PDSESHARING(EXTENDED) in the IGDSMSxx member of SYS1.PARMLIB for each z/OS system in the sysplex.

5. Code the CATALOG section of the DFSDFxxx member in the IMS PROCLIB data set, but do not yet enable the IMS catalog or the IMS management of ACBS. Specify CATALOG=N, ALIAS=xxxx, and ACBMGMT=ACBLIB.

Optionally, if you want to specify a high-level qualifier for the directory data sets that is different from the high-level qualifier of the IMS catalog database data sets, use the **SYSDSHLQ=** parameter in a dynamic allocation macro (DFSMDA). Specify the **SYSDSHLQ=** parameter in a TYPE=CATDSHLQ statement in the DFSMDA macro.

The following example shows a specification of the <CATALOG> section of the DFSDFxxx member before the IMS catalog is created:

```
<SECTION=CATALOG>
CATALOG=N,
ALIAS=DFSC
DATACLAS=,
MGMTCLAS=,
RETENTION=(VERSIONS=010),
STORCLAS=MEDIUM,
ACBMGMT=ACBLIB
```

6. Define the HALDB master database and partitions of the IMS catalog. Choose one of the following options:

- “Defining the IMS catalog with DBRC” on page 271: Use the Database Recovery Control utility (DSPURX00) to register the IMS catalog with DBRC and to define the master database and partitions in the RECON data sets.
- “Defining the IMS catalog without DBRC” on page 272: Create a DFSMDA member of the IMS.PROCLIB data set to allocate the catalog partition definition data set, then use the IMS Catalog Partition Definition Data Set utility (DFS3UCD0) to create the database. Set the name of the IMS catalog database and secondary index in the UNREGCATLG parameter in the DFSDFxxx member of the IMS.PROCLIB data set. This procedure creates a stand-alone data set with the catalog partition definitions so that you do not need DBRC to manage the catalog database. This option does not require DBRC, but you can use an unregistered IMS catalog in an IMS system with DBRC if necessary.

7. Estimate the size of the HALDB partition data sets of the IMS catalog by running the DFS3PU00 utility with the DFSCP000 PSB. If you are going to enable the IMS management of ACBs, the DFSDFxxx member must not yet specify ACBMGMT=CATALOG.

The following is an output example of running the DFS3PU00 utility with the DFSCP000 PSB. You might need to partition the catalog according to the estimation if necessary:

```
//LOADCAT EXEC PGM=DFS3PU00,REGION=7M,
// PARM=(DLI,DFS3PU00,DFSCP000,,,,,,,,,,,,,Y,N,,,,,,,,,,,,,'DFSDF=001')
//STEPLIB DD DSN=IMSVS.IMEC.EXITLIB,DISP=SHR
// DD DSN=IMSVS.IMEC.SDFSRESL,DISP=SHR
//DFSRESLB DD DSN=IMSVS.IMEC.SDFSRESL,DISP=SHR
//IMS DD DSN=IMSVS.IMEC.PSBLIB,DISP=SHR
// DD DSN=IMSVS.IMEC.DBDLIB,DISP=SHR
//PROCLIB DD DSN=IMSVS.IMEC.PROCLIB,DISP=SHR
//SYSABEND DD SYSOUT=* DUMP DATA SET
//SYSPRINT DD SYSOUT=* MESSAGES, STATISTICS
//IEFORDER DD DSN=IMSVS.IMEC.SLDS(+1),DISP=(,CATLG),
// UNIT=SYSDA,SPACE=(CYL,(10,10),RLSE)
//DFSVSAMP DD DSN=IMSVS.IMEC.UTIL(VSAMP),DISP=SHR
//IMSACB01 DD DSN=IMSVS.IMEC.ACBLIB,DISP=SHR
//SYSINP DD *
```

TOTALS FOR ALL PARTITIONS

ESTIMATED NUMBER OF SEGMENTS TO INSERT INTO THE CATALOG					
SC	SEGMENT	INSERTED SEGMENTS	DSG	PARENT	AVERAGE SEGS/PARENT
1	HEADER	1272	A		
2	DBD	295	A	HEADER	0.2
5	DSET	253	D	DBD	0.9
9	SEGM	1065	B	DBD	3.6
12	FLD	1138	C	SEGM	1.1
14	MAR	1138	C	FLD	1.0
17	LCHILD	201	B	SEGM	0.2
20	XDFLD	48	B	LCHILD	0.2
37	PSB	977	A	HEADER	0.8
39	PCB	24488	B	PSB	25.1
41	SS	176024	B	PCB	7.2
45	DBDXREF	24769	D	PSB	25.4

ESTIMATED SPACE REQUIREMENT TO HOLD INSERTED SEGMENTS		
DSG	BLKSIZE	BLOCKS
A	8192	82

B	8192	11856
C	8192	329
D	8192	293
DSG	RECORDS	
---	-----	
L	24769	
X	1273	

For more information about sizing the IMS catalog data sets, see [“Size of IMS catalog data sets”](#) on page 266.

- If you need to manually create the database data sets for the IMS catalog, create the data sets now. Otherwise, IMS creates them automatically.

You can estimate the sizes of the data sets by running the IMS Catalog Populate utility (DFS3PU00) in analysis-only mode.

- Initialize the empty IMS catalog partition data sets with the [HALDB Partition Data Set Initialization utility \(DFSUPNT0\)](#) (Database Utilities).
- Code the JCL and input control statements of the DFS3PU00 utility:
 - On the EXEC parameter in the JCL for the DFS3PU00 utility, specify DFSCPL00 as the PSB. PSB DFSCPL00 directs the DFS3PU00 utility to update the IMS catalog in load mode. Any existing copy of the IMS catalog is deleted.
 - Specify one or more ACB libraries that contain the currently active ACBs by using the IMSACBnn DD statements.
 - If you are enabling the IMS management of ACBs, specify the MANAGEDACBS=SETUP control statement by using the SYSINP DD statement.

For more information, see [“Loading the IMS catalog with the DFS3PU00 utility”](#) on page 280.

For more information about enabling the IMS management of ACBs, see [Enabling IMS management of ACBs \(System Definition\)](#).

- Load the IMS catalog by running the DFS3PU00 utility in a DL/I batch region.



Attention: Do not restart IMS until the population of the IMS catalog is complete.

- Take an image copy of the loaded IMS catalog data sets. For more information about taking database image copies, see [Creating image copy data sets for future use \(Database Administration\)](#).
- Specify the enabling parameters for the IMS catalog and the IMS management of ACBs in the <CATALOG> section of the DFSDFxxx member in the IMS PROCLIB data set: CATALOG=Y and ACBMGMT=CATALOG.

The following example shows the specification of the <CATALOG> section of the DFSDFxxx member:

```
<SECTION=CATALOG>
CATALOG=Y,
ALIAS=DFSC
DATACLAS=,
MGMTCLAS=,
RETENTION=(VERSIONS=010),
STORCLAS=MEDIUM,
ACBMGMT=CATALOG,
```

- Update the CATALOG section of the DFSDFxxx member in the IMS.PROCLIB data set by specifying CATALOG=Y, an ALIAS name, and, if you are enabling the IMS management of ACBs, ACBMGMT=CATALOG.

The Catalog Definition user exit routine (DFS3CDX0) is provided as an alternative option for batch processing environments that do not use the DFSDFxxx member of the IMS.PROCLIB data set.

- After the population of the IMS catalog is complete, shut down and restart IMS.
- Optional: Remove the DD statements for the ACB libraries from the control region and DLISAS region JCL.

What to do next

If you intend to run the DFS3PU00 utility as a BMP, the access level of the IMS catalog must allow updates (ACCESS=UPDATE). (For more information, see the parameter description for **ACCESS=** in “[CATALOG and CATALOGxxxx sections of the DFSDFxxx member](#)” on page 756.) Unless the IMS management of ACBs is enabled, the default access level of the IMS catalog is read only. If you did not specify ACCESS=UPDATE in the <CATALOG> section of the DFSDFxxx PROCLIB member, you can change the access level of the IMS catalog by using either the **UPDATE DB** command or the **/START DB** command.

Related concepts

[“Defining the IMS catalog master database and partitions” on page 271](#)

The IMS catalog is a HALDB (high availability large database) database that is a partitioned, IMS full-function database type (ACCESS=PHIDAM,OSAM) with OSAM utilizing Physical Sequential data sets or VSAM Linear Data Sets. Prior to loading records into an IMS catalog, you must define the partitions to IMS.

Related reference

[IMS catalog utilities \(System Utilities\)](#)

[Application Control Blocks Maintenance utility \(DFSUACB0\) \(System Utilities\)](#)

[Database Description \(DBD\) Generation utility \(System Utilities\)](#)

[Program Specification Block \(PSB\) Generation utility \(System Utilities\)](#)

[The IMS Catalog Redpaper](#)

IMS management of ACBs

IMS can manage the runtime *application control blocks* (ACBs) for databases and program views for you. You can define databases and program views by using SQL DDL statements or by using the IMS generation utilities.

ACBs are the runtime blocks that represent the active databases and program views in online and batch IMS environments. They are created from the databases and program views that you define to the IMS system.

Most ACBs are pre-built, stored in a data set in binary format, and loaded into memory by the online IMS system or by batch application programs. Some application programs and some utilities, such as those that run in an offline DL/I batch region, build ACBs dynamically during run time.

When IMS manages ACBs, as indicated by ACBMGMT=CATALOG in the <CATALOG> section of the DFSDFxxx member, IMS stores ACBs in the IMS directory, a collection of system-managed data sets that are associated with an IMS catalog. The IMS directory data sets include data sets for the active ACBs, a staging data set for ACBs that are pending activation, and a boot strap data set that IMS uses to manage the IMS directory.

When IMS managed ACBs, IMS can build, activate, and load ACBs into memory dynamically when database and program view definitions are submitted to IMS by using SQL DDL statements. Upon receiving the SQL statements, IMS automatically updates the IMS catalog and can, if directed to do so, activate certain changes to database or program view definitions automatically.

Changes that are not activated automatically or that are saved in the staging data set for later activation, can be activated by issuing the IMS type-2 **IMPORT DEFN SOURCE (CATALOG)** command. IMS type-2 command support requires the Operations Manager (OM) and Structured Call Interface (SCI) components of the IMS Common Service Layer (CSL). In data sharing environments, the CSL Resource Manager (RM) component is also required.

Defining databases and program views with SQL DDL statements is an alternative to the process of coding DBD and PSB source, generating DBDs, PSBs, and ACBs with utilities, and performing an Online Change process to activate the resulting ACBs. The DDL statements can be submitted to IMS through a separate product, such as the IMS Enterprise Suite Explorer for Development.

When IMS manages ACBs, you can also still define databases and program views by using the DBD and PSB generation utilities and build ACBs by using either the ACB Maintenance utility or the ACB Generation and Catalog Populate utility (DFS3UACB).

If you use the DFS3UACB utility, in addition to building the ACBs, the utility can also update the IMS catalog and activate the ACBs by loading them into the IMS directory. If you do not use the DFS3UACB utility, you can achieve the same results by using the ACB Maintenance utility and the IMS Catalog Populate utility (DFS3PU00).

The IMS Catalog Directory Recovery utility (DFS3RU00) can also be used to rebuild the IMS directory and write the online resources into the IMS directory data sets.

Both the DFS3UACB and the DFS3PU00 utilities require exclusive access when they update the IMS directory directly. So, if the utilities are run in the UPDATE mode, the IMS systems that use the IMS catalog that is being updated must be shut down. To avoid shutting down the IMS systems, run the utilities in STAGE mode and add them to the IMS directory by using the **IMPORT DEFN SOURCE (CATALOG)** command.

In many cases, whether you use DDL or the generation utilities, new or changed ACBs are placed in the staging data set as pending changes and you must activate the ACBs by issuing the **IMPORT DEFN SOURCE (CATALOG)** command. The Online Change process is not used. In other cases, such as when you delete a resource, the changes to the ACBs are activated automatically.

When you enable IMS management of ACBs, IMS performance is similar to what it is when an ACB library is used. IMS uses the same amount of I/O to access IMS-managed ACBs as it does to access ACBs in an ACB library.

Before IMS can manage ACBs, IMS and the IMS catalog must be set up to support ACB management by running the DFS3PU00 utility with the MANAGEDACBS=SETUP control statement that you provide as input. After IMS is set up for ACB management, you specify ACBMGMT=CATALOG in the <CATALOG> section of the DFSDFxxx PROCLIB member.

Restrictions

The following restrictions currently apply to the IMS management of ACBs function.

Change coordination restrictions with the IMS management of ACBs

In data sharing environments, if ACBSHR=Y is specified, the activation of resource changes in IMS systems that share an IMS catalog is always coordinated globally by the **IMPORT DEFN SOURCE (CATALOG)** command. Activating resources locally or separately in the individual IMS systems that share the IMS catalog is not supported. If you require more control over the activation of resource changes in IMS systems that share ACBs, use a separate aliased IMS catalog to manage the ACBs for each IMS system.

Database utilities and region type restrictions

Some IMS database-related utilities, and some vendor products that use the UDR or ULU region type, might still require access to DBDLIB and PSBLIB data sets even when the IMS managed ACBs function is enabled.

The following IMS utilities still require the use of DBDLIB or PSBLIB data sets:

- DEDB Area Data Set Compare utility (DBFUMMH0)
- DEDB Area Data Set Create utility (DBFUMRIO)
- DEDB Sequential Dependent Delete utility (DBFUMDL0)
- DEDB Sequential Dependent Scan utility (DBFUMSC0)
- Database Surveyor utility (DFSPRSUR)
- HALDB Index/ILDS Rebuild utility (DFSPREC0)
- High-Speed DEDB Direct Reorganization utility (DBFUHDR0)
- Partial Database Reorganization utility (DFSPRCT1 and DFSPRCT2)
- Utility Control Facility (DFSUCF00)

IMS catalog population restrictions

If IMS manages ACBs, you must shut down IMS when you run one of the following utilities with the SETUP or the UPDATE parameter specified on the MANAGEDACBS= control statement:

- The IMS Catalog Populate utility (DFS3PU00)
- The ACB Generation and Catalog Populate utility (DFS3UACB)

However, you can run the DFS3PU00 utility with `MANAGEDACBS=STAGE` specified without shutting down IMS, even if IMS manages ACBs.

XRF does not support the IMS management of ACBs

The Extended Recovery Facility (XRF) function does not support the IMS management of ACBs.

Enabling IMS management of ACBs

The procedure for enabling the IMS management of ACBs differs depending on whether your installation already uses the IMS catalog, which is required for the IMS management of ACBs.

Enabling IMS management of ACBs in an IMS system that already uses the IMS catalog

If your IMS system is already configured to use the IMS catalog, you enable the IMS management of ACBs without having to enable the IMS catalog at the same time.

Before you begin

If you have recently migrated to a new release of IMS, make sure that the IMS system is stable and running with the IMS catalog enabled.

In data-sharing environments, evaluate the impact of enabling IMS-managed ACBs on your current configuration. If all IMS systems in the data-sharing group share a single IMS catalog, the effect of enabling the IMS management of ACBs is similar to having all IMS systems share a single ACB library.

Make sure that the ACB libraries that you provide as input to the IMS Catalog Populate utility (DFS3PU00) contain all of the ACBs that are currently active in the IMS system. The following catalog resources must be present in one of the ACB libraries:

- DFSCD000
- DFSCP000
- DFSCP001
- DFSCX000
- DFSCPL00

Do not enable the IMS management of ACBs in the `<CATALOG>` section of the `DFSDfxxx` member until after the DFS3PU00 utility successfully creates the IMS directory and loads it with the active ACBs. If necessary, you can explicitly specify `ACBMGMT=ACBLIB` in the `<CATALOG>` section of the `DFSDfxxx` `PROCLIB` member until the IMS directory is ready to be used. IMS will issue message DFS7443E and terminate with a 0071 abend during IMS initialization if IMS managed ACBs is enabled and one or more of the following required catalog resources is not present in the directory: DFSCD000, DFSCP000, DFSCP001, DFSCX000 and DFSCPL00.

The default access level of the IMS catalog changes from `ACCESS=READ` to `ACCESS=UPDATE` when the IMS management of ACBs is enabled. You can specify the access level explicitly in the `<CATALOG>` section of the `DFSDfxxx` member or change it later by using the **UPDATE DB** or **/START DB** command.

Recommendations:

Keep the DBD and PSB source statements and the ACB, DBD, and PSB libraries intact until you are certain that you will not need to fall back to the use of installation-managed ACBs.

Similarly, do not delete from any JCL the DD statements that refer to the ACB, DBD, or PSB libraries until you are certain that you will not need to fall back.

If your IMS catalog is not already configured to use SMS-managed data sets, enable SMS-managed data sets now. The IMS catalog options for SMS-managed data sets are specified in the `<CATALOG>` section of the `DFSDfxxx` member.

Procedure

To enable the IMS management of ACBs when you are already using the IMS catalog follow these steps:

1. Optional: Specify a high-level qualifier for the IMS directory data sets on the SYSDSHLQ parameter in a CATDSHLQ DFSMDA macro statement.

When the SYSDSHLQ parameter is not specified in the dynamic allocation macro (DFSMDA) statement, IMS derives the high-level qualifier for the directory data set, the boot strap data set, and the staging data set from the data set name prefix of the IMS catalog database data sets.

2. Code the JCL and input control statements of the DFS3PU00 utility:
 - On the EXEC parameter in the JCL for the DFS3PU00 utility, specify PSB DFSCP001 for update access to the IMS catalog or, if you need to delete and reload the IMS catalog, you can use the load PSB, DFSCPL00, instead, which directs the DFS3PU00 utility to update the IMS catalog in load mode.
 - Specify one or more ACB libraries that contain the currently active ACBs by using the IMSACBnn DD statements.
 - Specify the MANAGEDACBS=SETUP control statement by using the SYSINP DD statement.
3. Run the DFS3PU00 utility to set up the IMS catalog to manage ACBs. Make sure that you enabled the IMS catalog and specified the options for the IMS catalog as necessary in [“CATALOG and CATALOGxxxx sections of the DFSDFxxx member”](#) on page 756 before using the DFS3PU00 utility. Set ACBMGMT=ACBLIB in the CATALOG and CATALOGxxxx section of the DFSDFxxx member until the IMS directory data sets are populated .

The DFS3PU00 utility inserts any new or modified instances of DBDs or PSBs into the IMS catalog and loads all ACBs into the IMS directory data sets, which are IMS-managed system data sets that serve a similar purpose in the IMS system as the ACB library data sets. After an ACB is added to the IMS directory, the corresponding resources in the IMS catalog are flagged as active.
4. For batch application programs, add the IMS catalog and ACB management definitions to the batch environment by either updating the execution JCL to reference the DFSDFxxx PROCLIB member or by using the IMS Catalog Definition exit routine (DFS3CDX0), which provides the definitions without requiring you to modify the JCL.
5. In the <CATALOG> section of the DFSDFxxx member in the IMS.PROCLIB data set, specify ACBMGMT=CATALOG.
6. Restart all IMS systems that use the DFSDFxxx member in which ACBMGMT=CATALOG is specified.

What to do next

If you have utilities, tools, or processes that continue to require the ACB, DBD, and PSB libraries, the library members must match the resources that are flagged as active in the IMS catalog. To generate matching libraries after IMS is managing the ACBs, use the IMS Catalog Database Library utility (DFS3LU00).

Consider setting the CATALOG field of the RECON data set if you need DBRC to read DBD information from an IMS catalog registered with DBRC. You can set the CATALOG field by using the CHANGE.RECON command. If you do not specify the field, DBRC reads DBD information from the DBDLIB. For more information, see [DBRC access to DBD information when IMS manages ACBs \(System Administration\)](#).

Related concepts

[Overview of the IMS catalog \(Database Administration\)](#)

Related reference

[IMS Catalog Populate utility \(DFS3PU00\) \(System Utilities\)](#)

[IMS Catalog Library Builder utility \(DFS3LU00\) \(System Utilities\)](#)

[“CATALOG and CATALOGxxxx sections of the DFSDFxxx member”](#) on page 756

The CATALOG and CATALOGxxxx sections contain options for an IMS catalog. The section headers must be specified as <SECTION=CATALOG> or <SECTION=CATALOGxxxx>. The CATALOG and CATALOGxxxx sections are valid in DB/DC, DBCTL, DCCTL and batch environments.

Enabling the IMS management of ACBs and the IMS catalog at the same time

If your installation does not already use the IMS catalog, you must enable the IMS catalog when you enable IMS management of application control blocks (ACBs).

Before you begin

If you recently migrated to a new release of IMS, be sure that the IMS system is stable before you enable the IMS catalog and the IMS management of ACBs.

In data-sharing environments, evaluate the impact of enabling the IMS management of ACBs on your current configuration. Ideally, all IMS systems in the data-sharing group share a single IMS catalog. When the IMS management of ACBs is enabled, sharing a single IMS catalog is similar to sharing a single ACB library.

You can use either the IMS Catalog Populate utility (DFS3PU00) or the ACB Generation and Populate utility (DFS3UACB) to populate the IMS catalog and set up IMS for the management of ACBs. The utilities create and allocate all of the IMS catalog database data sets automatically, but if you need to, you can define them yourself.

Make sure that the ACB libraries that you provide as input to the IMS Catalog Populate utility (DFS3PU00) contain all of the ACBs that are currently active in the IMS system. The following catalog resources must be present in one of the ACB libraries:

- DFSCD000
- DFSCP000
- DFSCP001
- DFSCX000
- DFSCPL00

Until the DFS3PU00 utility completes the population of the IMS catalog and the setup of the IMS management of ACBs, CATALOG=NO and ACBGMT=ACBLIB must remain in effect for that IMS system. These values are the default values, but if necessary, you can specify them explicitly in the <CATALOG> section of the DFSDFxxx member of the IMS.PROCLIB data set that the IMS system uses.

Recommendations:

If you do not already use the IMS Common Service Layer (CSL), configure and enable CSL before you enable the IMS management of ACBs. To activate database and program view changes in online IMS systems without shutting down IMS, CSL is required. Database and program view changes are activated by the IMS type-2 command **IMPORT DEFN SOURCE (CATALOG)**. IMS type-2 commands require the Operations Manager (OM) and the Structured Call Interface components of CSL. If you use data sharing, the CSL Resource Manager (RM) component is required.

Keep the database descriptor (DBD) and program specification block (PSB) source statements that define your databases and program views, as well as the ACB, DBD, and PSB libraries, intact and current until you are certain that all of your tools, automation, and operational procedures support the IMS management of ACBs and you do not need to fall back to user-managed ACBs.

Similarly, in your job control language (JCL), do not delete any DD statements that refer to the ACB, DBD, or PSB libraries until you are certain that you do not need to fall back.

Use the z/OS Storage Management Subsystem (SMS) to manage the IMS catalog data sets. The SMS options for the IMS catalog are specified in the <CATALOG> section of the DFSDFxxx PROCLIB member.

Procedure

To enable the IMS catalog and the IMS management of ACBs follow these steps:

1. Set up the IMS catalog:

- a) Install the DBDs and PSBs for the IMS catalog from the IMS.SDFSRESL data set to the IMS.DBDLIB and IMS.PSBLIB data sets.

The catalog DBDs are called DFSCD000 and DFSCX000. The PSBs are called DFSCPL00, DFSCP000, DFSCP001, DFSCP002, and DFSCP003. These names are reserved and cannot be changed or used for other resources.

- b) Run the ACB Maintenance utility to generate the ACB for the IMS catalog.

For example, JCL for the ACB Maintenance utility, see [Install the DBDs and PSBs for the IMS catalog](#).

- c) Activate the ACB library that contains the IMS catalog ACB.

- d) Code the CATALOG section of the DFSDfxxx member in the IMS PROCLIB data set, but do not yet enable the IMS catalog or the IMS management of ACBS. Specify CATALOG=N, ALIAS=xxxx, and ACBMGMT=ACBLIB.

Optionally, if you want to specify a high-level qualifier for the directory data sets that is different from the high-level qualifier of the IMS catalog database data sets, use the **SYSDSHLQ=** parameter in a dynamic allocation macro (DFSMDA). Specify the **SYSDSHLQ=** parameter in a TYPE=CATDSHLQ statement in the DFSMDA macro.

The following example shows a specification of the <CATALOG> section of the DFSDfxxx member before the IMS catalog is created:

```
<SECTION=CATALOG>
CATALOG=N,
ALIAS=DFSC
DATACLAS=,
MGMTCLAS=,
RETENTION=(VERSIONS=010),
STORCLAS=MEDIUM,
ACBMGMT=ACBLIB
```

- e) Define the HALDB master database and partitions of the IMS catalog. Choose one of the following options:

- [“Defining the IMS catalog with DBRC” on page 271](#): Use the Database Recovery Control utility (DSPURX00) to register the IMS catalog with DBRC and to define the master database and partitions in the RECON data sets.
- [“Defining the IMS catalog without DBRC” on page 272](#): Create a DFSMDA member of the IMS.PROCLIB data set to allocate the catalog partition definition data set, then use the IMS Catalog Partition Definition Data Set utility (DFS3UCD0) to create the database. Set the name of the IMS catalog database and secondary index in the UNREGCATLG parameter in the DFSDfxxx member of the IMS.PROCLIB data set. This procedure creates a stand-alone data set with the catalog partition definitions so that you do not need DBRC to manage the catalog database. This option does not require DBRC, but you can use an unregistered IMS catalog in an IMS system with DBRC if necessary.

- f) Estimate the size of the HALDB partition data sets of the IMS catalog by running the DFS3PU00 utility with the DFSCP000 PSB. If you are going to enable the IMS management of ACBs, the DFSDfxxx member must not yet specify ACBMGMT=CATALOG.

The following is an output example of running the DFS3PU00 utility with the DFSCP000 PSB. You might need to partition the catalog according to the estimation if necessary:

```
//LOADCAT EXEC PGM=DFS3PU00,REGION=7M,
// PARM=(DLI,DFS3PU00,DFSCP000,,,,,,,,,,,,,Y,N,,,,,,,,,,,,,'DFSDf=001')
//STEPLIB DD DSN=IMSVS.IMEC.EXITLIB,DISP=SHR
// DD DSN=IMSVS.IMEC.SDFSRESL,DISP=SHR
//SDFSRESLB DD DSN=IMSVS.IMEC.SDFSRESL,DISP=SHR
//IMS DD DSN=IMSVS.IMEC.PSBLIB,DISP=SHR
// DD DSN=IMSVS.IMEC.DBDLIB,DISP=SHR
//PROCLIB DD DSN=IMSVS.IMEC.PROCLIB,DISP=SHR
//SYSABEND DD SYSOUT=* DUMP DATA SET
//SYSPRINT DD SYSOUT=* MESSAGES, STATISTICS
//IEFRDER DD DSN=IMSVS.IMEC.SLDS(+1),DISP=(,CATLG),
```

```
// UNIT=SYSDA,SPACE=(CYL,(10,10),RLSE)
//DFSVSAMP DD DSN=IMSVS.IMEC.UTIL(VSAMP),DISP=SHR
//IMSACB01 DD DSN=IMSVS.IMEC.ACBLIB,DISP=SHR
//SYSINP DD *
```

TOTALS FOR ALL PARTITIONS

SC	SEGMENT	ESTIMATED NUMBER OF SEGMENTS TO BE INSERTED INTO THE CATALOG	DSG	PARENT	AVERAGE SEGS/PARENT
1	HEADER	1272	A		
2	DBD	295	A	HEADER	0.2
5	DSET	253	D	DBD	0.9
9	SEGM	1065	B	DBD	3.6
12	FLD	1138	C	SEGM	1.1
14	MAR	1138	C	FLD	1.0
17	LCHILD	201	B	SEGM	0.2
20	XDFLD	48	B	LCHILD	0.2
37	PSB	977	A	HEADER	0.8
39	PCB	24488	B	PSB	25.1
41	SS	176024	B	PCB	7.2
45	DBDXREF	24769	D	PSB	25.4

ESTIMATED SPACE REQUIREMENT TO HOLD INSERTED SEGMENTS

DSG	BLKSIZE	BLOCKS
A	8192	82
B	8192	11856
C	8192	329
D	8192	293

DSG	RECORDS
L	24769
X	1273

For more information about sizing the IMS catalog data sets, see [“Size of IMS catalog data sets”](#) on page 266.

- g) If you need to manually create the database data sets for the IMS catalog, create the data sets now. Otherwise, IMS creates them automatically.
 - h) Initialize the empty IMS catalog partition data sets with the [HALDB Partition Data Set Initialization utility \(DFSUPNT0\)](#) (Database Utilities).
2. Code the JCL and input control statements of the DFS3PU00 utility:

- On the EXEC parameter in the JCL for the DFS3PU00 utility, specify DFSCPL00 as the PSB. PSB DFSCPL00 directs the DFS3PU00 utility to update the IMS catalog in load mode. Any existing copy of the IMS catalog is deleted.
- Specify one or more ACB libraries that contain the currently active ACBs by using the IMSACBnn DD statements.
- Specify the MANAGEDACBS=SETUP control statement by using the SYSINP DD statement.

The following code is an example of the JCL required for the DFS3PU00 utility:

```
//LOADCAT EXEC PGM=DFS3PU00,REGION=7M,
// PARM=(DLI,DFS3PU00,DFSCPL00,,,,,,,,,,,,,Y,N,,,,,,,,,,,,,'DFSDF=001')
//STEPLIB DD DSN=IMS.EXITLIB,DISP=SHR
// DD DSN=IMS.SDFSRESL,DISP=SHR
//DFSRESLB DD DSN=IMS.SDFSRESL,DISP=SHR
//IMS DD DSN=IMS.PSBLIB,DISP=SHR
// DD DSN=IMS.DBDLIB,DISP=SHR
//PROCLIB DD DSN=IMS.PROCLIB,DISP=SHR
//SYSABEND DD SYSOUT=* DUMP DATA SET
//SYSPRINT DD SYSOUT=* MESSAGES, STATISTICS
//IEFRDR DD DSN=IMS.SLDS(+1),DISP=(,CATLG),
// UNIT=SYSDA,SPACE=(CYL,(10,10),RLSE)
//DFSVSAMP DD DSN=IMS.UTIL(VSAMP),DISP=SHR
//IMSACB01 DD DSN=IMS.ACBLIB,DISP=SHR
//SYSINP DD *
DUPLIST
ISRTLIST
MANAGEDACBS=SETUP
```

For more information, see [“Loading the IMS catalog with the DFS3PU00 utility”](#) on page 280.

3. Run the DFS3PU00 utility to set up the IMS catalog to manage ACBs. Make sure that you enabled the IMS catalog and specified the options for the IMS catalog as necessary in [“CATALOG and CATALOGxxxx sections of the DFSDFxxx member”](#) on page 756 before using the DFS3PU00 utility. Set ACBMGMT=ACBLIB in the CATALOG and CATALOGxxxx section of the DFSDFxxx member until the IMS directory data sets are populated .

The DFS3PU00 loads the database and program view definitions into the IMS catalog, creates the system-managed IMS directory data sets, and loads the ACBs into the active ACB data sets of the IMS directory. When the IMS systems that use the IMS catalog restart, they load the active ACBs from the IMS directory.



Attention: Do not restart IMS until the population of the IMS catalog is complete.

4. For batch application programs, add the IMS catalog and ACB management definitions to the batch environment by either updating the execution JCL to reference the DFSDFxxx PROCLIB member or by using the IMS Catalog Definition exit routine (DFS3CDX0), which provides the definitions without requiring you to modify the JCL.
5. Specify the enabling parameters for the IMS catalog and the IMS management of ACBs in the <CATALOG> section of the DFSDFxxx member in the IMS PROCLIB data set: CATALOG=Y and ACBMGMT=CATALOG.

The following example shows the specification of the <CATALOG> section of the DFSDFxxx member:

```
<SECTION=CATALOG>
CATALOG=Y,
ALIAS=DFSC
DATACLAS=,
MGMTCLAS=,
RETENTION=(VERSIONS=010),
STORCLAS=MEDIUM,
ACBMGMT=CATALOG,
```

6. After the population of the IMS catalog is complete, restart all IMS systems that use the IMS catalog.

What to do next

If you have utilities, tools, or processes that continue to require the ACB, DBD, and PSB libraries, the library members must match the resources that are flagged as active in the IMS catalog. To generate matching libraries after IMS is managing the ACBs, use the IMS Catalog Database Library utility (DFS3LU00).

Consider setting the CATALOG field of the RECON data set if you need DBRC to read DBD information from an IMS catalog registered with DBRC. You can set the CATALOG field by using the CHANGE.RECON command. If you do not specify the field, DBRC reads DBD information from the DBDLIB. For more information, see [DBRC access to DBD information when IMS manages ACBs \(System Administration\)](#).

Related concepts

[Overview of the IMS catalog \(Database Administration\)](#)

Related reference

[IMS Catalog Populate utility \(DFS3PU00\) \(System Utilities\)](#)

[CATALOG and CATALOGxxxx sections of the DFSDFxxx member \(System Definition\)](#)

[IMS Catalog Library Builder utility \(DFS3LU00\) \(System Utilities\)](#)

Falling back from IMS-managed ACBs to installation-managed ACBLIBs

The procedure for falling back from the IMS management of ACBs to the installation-managed ACB libraries (ACBLIBs) is different depending on whether your installation has activated any new or modified databases or program views since the IMS management of ACBs was enabled.

Falling back from IMS-managed ACBs before resource updates are activated

If your installation has not activated any new or modified databases or program views since enabling the IMS management of ACBs and your ACB, DBD, and PSB libraries are unchanged, the procedure for falling back from the IMS management of ACBs to the installation-managed ACB libraries (ACBLIBs) involves updating the DFSDFxxx member, changing various references to the IMS catalog back to references to the ACB, DBD, and PSB libraries, and restarting IMS.

About this task

The following procedure does not include steps for falling back from an IMS catalog. Disabling the IMS catalog is not required when falling back to installation-managed ACBLIBs.

The following procedure is generally applicable to both falling back within a release and falling back to a prior release of IMS.

Procedure

1. In the <CATALOG> section of the DFSDFxxx PROCLIB member, specify ACBMGMT=ACBLIB.
2. If you use the IMS Catalog Definition exit routine (DFS3CDX0), modify it to indicate that the IMS management of ACBs is not enabled.
3. If necessary, update any JCL to reference the ACBLIB, DBDLIB, and PSBLIB.
4. If DBRC was configured to refer to the IMS catalog for database definitions, reconfigure DBRC to refer to the DBDLIB instead by issuing the **CHANGE . RECON** command with NOCATALG specified.
5. Restart IMS.

What to do next

Before running the IMS Catalog Populate utility (DFS3PU00) again on a system that uses ACB libraries, remove the MANAGEDACBS control statement from the JCL.

If necessary, revert any tools or products that were updated to run in the IMS-managed ACBs environment so that they use the ACB, DBD, and PSB libraries again.

Falling back from IMS-managed ACBs after resource updates were activated

If your installation has activated new or modified databases or program views after enabling the IMS management of ACBs, the procedure for falling back to installation-managed ACB libraries (ACBLIBs) includes recreating the DBD, PSB, and ACB libraries from the active resources in the IMS catalog.

About this task

The following procedure does not include steps for falling back from an IMS catalog. Disabling the IMS catalog is not required when falling back to installation-managed ACBLIBs.

The following procedure is generally applicable to both falling back within a release and falling back to a prior release of IMS.

Procedure

1. Build the input statements for DBD Generation and PSB Generation utilities from the IMS catalog by using the DFS3LU00 utility.
2. Build the DBD and PSB libraries by running the DBD and PSB Generation utilities.
If you are falling back to a prior release of IMS, be sure to use the utilities for that release of IMS.
3. Build the ACB library by providing the DBD and PSB libraries as input to the ACB Maintenance utility.
If you are falling back to a prior release of IMS, be sure to use the utilities for that release of IMS.
4. In the <CATALOG> section of the DFSDFxxx PROCLIB member, specify ACBMGMT=ACBLIB.

5. If you use the IMS Catalog Definition exit routine (DFS3CDX0), modify it to indicate that the IMS management of ACBs is not enabled.
6. If necessary, update any JCL to reference the ACBLIB, DBDLIB, and PSBLIB.
7. If DBRC was configured to refer to the IMS catalog for database definitions, reconfigure DBRC to refer to the DBDLIB instead by issuing the **CHANGE . RECON** command with NOCATALG specified.
8. Restart the IMS system.

What to do next

Remove the MANAGEDACBS control statement from the JCL for the IMS Catalog Populate utility (DFS3PU00) before running the utility again on a system that uses ACB libraries.

If necessary, revert any tools or products that were updated to run in the IMS-managed ACBs environment so that they use the ACB, DBD, and PSB libraries again.

References to ACB, DBD, and PSB resources when ACBs are managed by IMS

When the IMS management of ACBs is enabled, IMS procedures no longer need to reference the ACB, DBD, or PSB libraries. Instead, IMS retrieves these resources from the IMS catalog when they are needed.

To retrieve the resources from the IMS catalog, IMS procedures must either reference the DFSDFxxx PROCLIB member that contains the IMS catalog specifications or an IMS Catalog Definition exit routine (DFS3CDX0) must be supplied that provides the specifications.

When IMS manages ACBs, IMS ignores references in JCL to the ACB, DBD, and PSB libraries for utilities, programs, or IMS components that run in the following regions or environments:

- An offline DL/I batch processing region that is established by the DBBBATCH procedure
- A DBCTL environment that is established by the DBC procedure
- A DCCTL environment that is established by the DCC procedure
- A DL/I separate address space that is established by the DLISAS procedure
- A FDBR address space that is established by the FDR procedure
- A IMS DB/DC environment that is established by the IMS procedure
- Online dependent regions that use GSAM
- ULU (unload and reload) regions

GSAM databases and IMS management of ACBs

When the IMS management of ACBs is enabled, IMS stores the definitions for GSAM databases in the IMS catalog. The runtime control blocks are stored in the IMS directory, a system-managed extension of the IMS catalog that is generally equivalent to the ACB library (ACBLIB) in systems that use an ACBLIB.

In IMS systems that use ACBLIBs, the GSAM control blocks are not stored in the ACBLIB, but are instead loaded from the DBDLIB. Therefore, when you enable the IMS management of ACBs, you are not only relieved of having to manage both ACBLIB and DBDLIB data sets, but IMS stores and manages the GSAM definitions and control blocks for you, in essentially the same way that it does for other database types.

Each time a BMP application program that requires a GSAM database is scheduled in a dependent region, IMS loads the runtime control blocks for the GSAM database from the IMS catalog.

When the IMS management of ACBs is enabled for the first time by running the IMS Catalog Populate utility (DFS3PU00) with the MANAGEDACBS control statement, the utility creates DBD records in the IMS catalog for GSAM metadata and loads the GSAM control blocks into the system-managed data sets of the IMS catalog.

As a result, when IMS manages ACBs, the IMS catalog contains a DBD record for each GSAM database that was added by the IMS Catalog Populate utility. When the IMS management of ACBs is not enabled, the IMS catalog does not contain a DBD record for every GSAM database.

Installing the IMS catalog DBDs and PSBs

Like other types of IMS databases, the structure of the IMS catalog is defined by database descriptions (DBDs), and access to the IMS catalog is defined by program specification blocks (PSBs).

About this task

The DBDs and PSBs for the IMS catalog are shipped as DBDGEN and PSBGEN output (load modules) that you must copy to your IMS.DBDLIB and IMS.PSBLIB data sets before you can use the IMS catalog. The load modules are included in the IMS.SDFSRESL data set. You do not need to use the DBD or PSB generation utilities before including the catalog resource modules in your ACB library.

After copying the DBDs and PSBs for the IMS catalog into your DBDLIB and PSBLIB, you must run the ACB Maintenance utility to generate the ACBs for the IMS catalog.

If you choose to define alias names for the IMS catalog, you must update the DBDLIB members using the IMS catalog alias names utility (DFS3ALIO) either during or at any time after installation.

You do not need to define the MODBLKS resources for the IMS catalog database or programs. IMS manages the catalog MODBLKS internally.

The DBDs for the IMS catalog include:

DFSCD000

Defines the IMS catalog database

Restriction: This DBD defines an IMS full-function database type (ACCESS=PHIDAM,OSAM) with OSAM utilizing Physical Sequential data sets or VSAM Linear Data Sets.

DFSCX000

Defines the IMS catalog secondary index

The PSBs for the IMS catalog are used by primarily by internal IMS processes.

IMS automatically increases the space allocated for the user PSB to attach the catalog PSBs. 96 bytes of additional space are allocated for each user PSB in the PSB CSA storage pool. The catalog PSB itself occupies 12kb in the DLIPSB pool and 500 bytes CSAPSB pool for each user PSB that uses the catalog PSBs. You might need to increase the size of your storage pools, up to the maximum size of the catalog PSB in each pool multiplied by the number of user PSBs that concurrently access the catalog.

The IMS catalog PSBs include:

DFSCPL00

For an initial load of the IMS catalog by either the IMS Catalog Populate utility (DFS3PU00) or the ACB Generation and Populate utility (DFS3UACB).

DFSCP000

Provides read access to the IMS catalog for the DFS3PU00 utility and other COBOL or high-level assembler programs.

DFSCP001

Provides update access to the IMS catalog for the DFS3PU00 utility and the DFS3UACB utility.

DFSCP002

Provides read access to the IMS catalog for PL/I programs.

DFSCP003

Provides read access to the IMS catalog for PASCAL programs.

DFSCP004

A place holder for future catalog enhancements. Will be displayed as NOTINIT during IMS control region initialization and if displayed by the /DIS STATUS PGM or QUERY PGM NAME(NAME*) SHOW(STATUS) commands.

DFSCP005

A place holder for future catalog enhancements. Will be displayed as NOTINIT during IMS control region initialization and if displayed by the /DIS STATUS PGM or QUERY PGM NAME(NAME*) SHOW(STATUS) commands.

Procedure

1. To copy the DBD and PSB load modules from IMS.SDFSRESL to your DBDLIB and PSBLIB, use the following JCL job:

```
//COPYRES EXEC PGM=IEBCOPY
//SYSPRINT DD SYSOUT=*
//SDFSRESL DD DSN=IMS.SDFSRESL,DISP=SHR
//DBDLIB DD DSN=MYIMS.DBDLIB,DISP=OLD
//PSBLIB DD DSN=MYIMS.PSBLIB,DISP=OLD
//SYSIN DD *
        COPYMOD OUTDD=DBDLIB,INDD=((SDFSRESL,R)),LIST=YES
        SELECT MEMBER=(DFSCD000,DFSCX000)
        COPYMOD OUTDD=PSBLIB,INDD=((SDFSRESL,R)),LIST=YES
        SELECT MEMBER=(DFSCPL00,DFSCP000,DFSCP001,DFSCP002,DFSCP003)
/*
```

COPYMOD rather than COPY is recommended if the DBDLIB or PSBLIB being copied to has a smaller block size than the .SDFSRESL data set.

2. Run the ACBGEN process for the catalog DBD and PSB members.

Use the following JCL job:

```
//CATACB EXEC PGM=DFSRR00,PARM='UPB'
//SYSPRINT DD SYSOUT=*
//STEPLIB DD DSN=IMS.SDFSRESL,DISP=SHR
//DFSRESLB DD DSN=IMS.SDFSRESL,DISP=SHR
//IMS DD DSN=MYIMS.PSBLIB,DISP=SHR
// DD DSN=MYIMS.DBDLIB,DISP=SHR
//IMSACB DD DSN=IMS.ACBLIB,DISP=OLD
//SYSIN DD *
        BUILD PSB=(DFSCPL00)
        BUILD PSB=(DFSCP000)
        BUILD PSB=(DFSCP001)
        BUILD PSB=(DFSCP002)
        BUILD PSB=(DFSCP003)
/*
```

3. Activate the new IMS catalog ACB members in your IMS system.

Choose one of the following options:

- Copy the new ACBLIB members to an inactive staging ACBLIB and then activate the staging ACBLIB to make the IMS catalog resources available for use.
- Copy the new ACBLIB members directly to an active ACBLIB with Online Change or Member Online Change.

IMS catalog data sets

The data sets for the IMS catalog can be created automatically by the IMS Catalog Populate utility (DFS3PU00).

Optionally, you can create the database data sets for the IMS catalog yourself.

The IMS catalog database comprises the following data sets:

- In each partition, the data sets for the IMS catalog database, DFSCD000:
 - Primary index data set
 - Indirect list data set (ILDS)
 - Four data set groups for the segments of the IMS catalog records (A - D)
- The data set for the secondary index database, DFSCX000

If the IMS management of application control blocks (ACBs) is enabled, the following system-managed data sets are also associated with the IMS catalog:

- One or more IMS directory data sets
- A bootstrap data set
- A staging data set

For a managed ACBs environment and when the ACBSHR= parameter is set to Y (ACBSHR=Y), all data sharing IMSs use the same set of IMS catalog data sets, IMS directory data sets, a bootstrap data set, and a staging data set. If a data sharing IMS has an FDBR region, the FDBR region shares the same set of catalog-related data sets as its active IMS.

For a managed ACBs environment and when the ACBSHR= parameter is set to N (ACBSHR=N), each data sharing IMS uses its own set of IMS catalog data sets, IMS directory data sets, a bootstrap data set, and a staging data set. If a data sharing IMS has an FDBR region, the FDBR region shares the same set of catalog-related data sets as its active IMS.

In addition, for IMS managed ACBs and ACBSHR=N, each sharing IMS must have a different ALIAS defined in the SECTION_CATALOG of DFSDFxxx PROCLIB. The different ALIAS for each sharing IMS is used to create its unique set of IMS catalog data sets, catalog directory data sets, a bootstrap data set, and a staging data set. If a sharing IMS has an FDBR region, the same IMS catalog and its catalog-related data sets are shared between the active IMS and the FDBR region that are using the same ALIAS.

The DFS3PU00 utility automatically creates any IMS catalog data sets that do not exist.

The system-managed data sets can also be created manually.

The DFS3PU00 utility calculates the size of the database data sets based on both the size of the ACB library and the expansion percentages that you can specify in the DFSDFxxx PROCLIB member.

The DFSDFxxx PROCLIB member is also where you specify the volume serial number for the VSAM key-sequenced data sets or the SMS storage class, data class, and management class for all data sets.

As a HALDB PHIDAM database, the IMS catalog can have one or more partitions. Each partition contains a primary index data set, an ILDS, and four data set groups.

Related tasks

[“Creating the database data sets of the IMS catalog manually” on page 264](#)

To define and create the IMS catalog database data sets yourself, you can use JCL and IDCAMS commands.

Related reference

[“IMS catalog data set groups” on page 268](#)

The IMS catalog database segment types are organized into four data set groups, A - D.

[IMS Catalog Populate utility \(DFS3PU00\) \(System Utilities\)](#)

Creating the database data sets of the IMS catalog manually

To define and create the IMS catalog database data sets yourself, you can use JCL and IDCAMS commands.

About this task

When the IMS management of ACBs is enabled, the IMS catalog uses additional system data sets that cannot be created manually. These data sets are considered extensions of the IMS catalog and include the IMS directory data sets, an IMS directory staging data set, and an IMS directory bootstrap data set. IMS creates these system data sets automatically the first time you load ACBs into the IMS catalog when you enable the IMS management of ACBs. IMS automatically allocates additional data sets for the IMS directory if the existing data sets of the IMS directory reach their capacity.

Note: The IMS catalog is a full-function database type (ACCESS=PHIDAM,OSAM) supporting OSAM Physical Sequential data sets or VSAM Linear Data Sets.

HALDB databases use a data set naming convention that requires specific suffixes on the data set names. For example, A00001, X00001, and so on. You must use these suffixes as shown in the examples in the following steps.

For the VSAM data sets for the primary index, secondary index, and the indirect list data set (ILDS), the KEYS and RECORDSIZE parameters must be specified as shown in the following example for each.

To help determine the sizes to enter for the database data sets, the primary index data set, the ILDS, and the secondary index data set, you can run the IMS Catalog Populate utility with the DFSCP000 PSB to generate size estimates that are based on your ACB library.

Procedure

1. Create the partition data sets by using JCL.

For example:

```
//DFSC001A DD DSN=dsnprefix.DFSCD000.A00001,DISP=(NEW,CATLG),
//          SPACE=(CYL,(primary,secondary)),
//          UNIT=name,VOL=SER=volser
//DFSC001B DD DSN=dsnprefix.DFSCD000.B00001,DISP=(NEW,CATLG),
//          SPACE=(CYL,(primary,secondary)),
//          UNIT=name,VOL=SER=volser
//DFSC001C DD DSN=dsnprefix.DFSCD000.C00001,DISP=(NEW,CATLG),
//          SPACE=(CYL,(primary,secondary)),
//          UNIT=name,VOL=SER=volser
//DFSC001D DD DSN=dsnprefix.DFSCD000.D00001,DISP=(NEW,CATLG),
//          SPACE=(CYL,(primary,secondary)),
//          UNIT=name,VOL=SER=volser
```

Note: This example

2. Create the primary index data set, the ILDS data set, and the secondary index data set by using the following IDCAMS commands.

For example:

```
/* PRIMARY INDEX DATA SET          */
DEFINE CLUSTER ( -
        NAME (dsnprefix.DFSCD000.X00001) -
        CYL(primary,secondary) -
        REUSE -
        VOL(volser) -
        FREESPACE(80,10) -
        SHAREOPTIONS(3,3) -
        SPEED ) -
DATA ( -
        NAME(dsnprefix.DFSCD000.X00001.DATA) -
        CISZ(512) -
        KEYS(16,5) -
        RECORDSIZE(22,22) ) -
INDEX ( -
        NAME(dsnprefix.DFSCD000.X00001.INDEX) -
        CISZ(2048) )

/* INDIRECT LIST DATA SET          */
DEFINE CLUSTER ( -
        NAME (dsnprefix.DFSCD000.L00001) -
        CYL(primary,secondary) -
        REUSE -
        VOL(volser) -
        FREESPACE(80,10) -
        SHAREOPTIONS(3,3) -
        SPEED ) -
DATA ( -
        NAME(dsnprefix.DFSCD000.L00001.DATA) -
        CISZ(512) -
        KEYS(9,0) -
        RECORDSIZE(50,50) ) -
INDEX ( -
        NAME(dsnprefix.DFSCD000.L00001.INDEX) -
        CISZ(2048) )

/* SECONDARY INDEX DATA SET        */
```

```

DEFINE CLUSTER ( -
        NAME(dsnprefix.DFSCX000.A00001) -
        CYL(primary,secondary) -
        REUSE -
        VOL(volser) -
        INDEXED -
        KEYS(37,45) -
        RECORDSIZE(82,82) -
        FREESPACE(80,10) -
        SHAREOPTIONS(3,3) -
        SPEED ) -
        DATA (CISZ(4096) )

```

Related concepts

[Naming conventions for HALDB partitions, ddnames, and data sets \(Database Administration\)](#)

Size of IMS catalog data sets

Before creating the data sets for an IMS catalog, run the IMS Catalog Populate utility (DFS3PU00) in the analysis-only mode to determine the approximate storage requirements of the data sets on your DASD devices.

In analysis-only mode, the DFS3PU00 utility calculates the approximate size of the IMS catalog data sets by analyzing the contents of the ACB libraries that you provide as input to the utility. In analysis-only mode, the DFS3PU00 utility does not create the IMS catalog data sets.

The calculations of the utility do not include the data sets of the IMS directory, which is an extension of the IMS catalog that is used only when the IMS management of ACBs is enabled. The IMS directory is a system-managed replacement of the ACB libraries. If an IMS directory contained the same ACBs as an ACB library, the data sets of IMS directory might require only slightly more storage than the data sets of the ACB library. If the existing data sets of the IMS directory reach their capacity, IMS creates a new data set automatically to accommodate the growth. When IMS adds a data set, the IMS directory uses more storage.

To run the DFS3PU00 utility in analysis-only mode, specify DFSCP000 as the PSB for the utility in the utility JCL.

After the utility evaluates the members in your ACB libraries, it produces a report. This report is the same report that the DFS3PU00 utility produces when it loads the IMS catalog.

The first two sections provide statistics about the segments that would be inserted in the IMS catalog if it were loaded from the current input ACB libraries. The rest of the sections provide the storage estimates.

For the OSAM data sets, the storage sections of the report show the number of blocks of the specified size. For the VSAM KSDSs, which include the indirect list data set (ILDS), the primary index data set, and the secondary index data set, the report shows the number of VSAM records.

These numbers are estimates that reflect the amount of space needed to load the catalog records that are built from the ACB libraries that you provide as input to the DFS3PU00 utility. If you are calculating the amount of storage required for the IMS catalog data sets, provide plenty of additional space in your calculations to allow for expansion.

If you have IMS create the IMS catalog data sets automatically, you can specify additional space as a percentage of the estimates that are provided by the utility on the SPACEALLOC parameter in the IMS catalog section of the DFSDFxxx PROCLIB member. The default value for this parameter is 500%.

In the report, the following abbreviations are used:

DSG

Data set group

L

A HALDB ILDS data set. The number of records shown represent the potential number of indirect list entries (ILEs) that could be created if the IMS catalog is reorganized.

SC

Segment code. When loading a segment type, IMS assigns a segment code as a unique identifier (an integer from 1 to 255). IMS assigns numbers in ascending sequence, starting with the root segment type (number 1) and continuing through all dependent segment types in hierarchical sequence.

SEGS

Segments

X

HALDB partitioned primary index.

CATALOG DFSCD000

PARTITION DFSCD01

NUMBER OF SEGMENTS INSERTED INTO THE CATALOG

SC	SEGMENT	INSERTED SEGMENTS	DSG	PARENT	AVERAGE SEGS/PARENT
1	HEADER	4228	A		
2	DBD	2530	A	HEADER	0.6
3	CAPXDBD	7	D	DBD	0.0
5	DSET	2599	D	DBD	1.0
7	AREA	139	D	DBD	0.1
9	SEGM	16337	B	DBD	6.5
10	CAPXSEGM	1	D	SEGM	0.0
12	FLD	16426	C	SEGM	1.0
14	MAR	16426	C	FLD	1.0
17	LCHILD	2687	B	SEGM	0.2
20	XDFLD	134	B	LCHILD	0.0
33	PSB	1840	A	HEADER	0.4
35	PCB	9190	B	PSB	5.0
37	SS	75274	B	PCB	8.2
39	SF	1105	B	SS	0.0
41	DBDXREF	8886	D	PSB	4.8

SEGMENT	WITHIN EXISTING HEADER	DUPLICATES NOT INSERTED
DBD	71	0
PSB	72	0

ESTIMATED SPACE REQUIREMENT TO HOLD INSERTED SEGMENTS

DSG	BLKSIZE	BLOCKS
A	4096	596
B	4096	9343
C	4096	8214
D	4096	236

DSG	RECORDS
L	8886
X	4230

SECONDARY INDEX	RECORDS
DFSCX000	8886

Related reference

[“CATALOG and CATALOGxxxx sections of the DFSDfxxx member” on page 756](#)

The CATALOG and CATALOGxxxx sections contain options for an IMS catalog. The section headers must be specified as <SECTION=CATALOG> or <SECTION=CATALOGxxxx>. The CATALOG and CATALOGxxxx sections are valid in DB/DC, DBCTL, DCCTL and batch environments.

[IMS Catalog Populate utility \(DFS3PU00\) \(System Utilities\)](#)

IMS catalog data set groups

The IMS catalog database segment types are organized into four data set groups, A - D.

This information is provided to help you configure your IMS system for better catalog performance. Segment types are organized into data set groups A - D based on the expected frequency of access. Data set group A contains the most frequently accessed segment types and data set group D contains the least frequently accessed segment types.

Table 41. IMS catalog database segments and data set groups

Segment name	Data set group
HEADER	A
DBD	A
CAPXDBD	D
DBDRMK	D
DSET	D
DSETRMK	D
AREA	D
AREARMK	D
SEGM	B
CAPXSEGM	D
SEGMRMK	D
FLD	C
FLDRMK	D
MAR	C
MARRMK	D
PROP	C
LCHILD	B
LCHRMK	D
LCH2IDX	D
XDFLD	B
XDFLDRMK	D
MAP	B
MAPRMK	D
CASE	B
CASERMK	D
CFLD	B
CFLDRMK	D
CMAR	B
CMARRMK	D

Table 41. IMS catalog database segments and data set groups (continued)

Segment name	Data set group
CPROP	B
DBDVEND	D
PSB	A
PSBRMK	D
PCB	B
PCBRMK	D
SS	B
SSRMK	D
SF	B
SFRMK	D
DBDXREF	D
PSBVEND	D

Related concepts

[Multiple data set groups \(Database Administration\)](#)

IMS directory data sets

When the IMS management of application control blocks (ACBs) is enabled, IMS stores the active ACBs in the IMS directory, a collection of system-managed data sets that are an extension of the IMS catalog. The IMS directory data sets include data sets for the ACBs that are active in the IMS system, a staging data set for ACBs that are pending activation, and a bootstrap data set that IMS uses to manage the IMS directory.

The IMS directory data sets that store the active and pending ACBs are functionally similar to the ACB library (ACBLIB) data sets that you would use to manage ACBs when the IMS management of ACBs is not enabled.

Unlike an active ACBLIB data set, the active ACB data sets of the IMS directory are system data sets that IMS creates, updates, and manages automatically. IMS automatically allocates the data sets for the IMS directory and keeps the IMS directory in sync with the IMS catalog.

When databases and program views are created or modified by using SQL DDL statements, the ACBs are generated automatically and in most cases, are stored in the staging data set of the IMS directory. However, they cannot be used until they are activated in the IMS directory.

If you are using the IMS Catalog Populate utility (DFS3PU00) to add ACBs to the IMS system, the utility can either add them to the active ACB data sets of the IMS directory when it updates the IMS catalog or the utility can save the ACBs to the staging data set. To update the active ACB data sets directly, the IMS system must be shut down.

You activate ACBs that are in the staging data set of the IMS directory by using the **IMPORT DEFN SOURCE (CATALOG)** command, which copies the ACBs to the active ACB data sets by using an internal process that is similar to the online change process, but simpler.

The IMS directory uses PDSE data sets for the active ACBs and the staging data set.

Data set names of the IMS directory data sets

By default, the high-level qualifier (HLQ) of the IMS directory data sets are derived from the data set name prefix of the IMS catalog database data sets.

IMS defines the characters of the final qualifier for these data sets as follows:

IMS directory data sets

DI followed by a suffix that IMS creates automatically

IMS bootstrap data set

BSDS

Staging data set

STG

The data set name prefix of the IMS catalog database data sets from which the default HLQ of the directory data sets is derived, is defined in the RECON data set when the first partition is defined to DBRC or the IMS Catalog Definition exit routine (DFS3CDX0). If the IMS catalog is not registered with DBRC, the data set name prefix of the IMS catalog database data sets is defined in the partition definition data set (PDDS).

The following example shows the default names for the IMS directory data sets if you were to specify DSNPREFIX (IMSTEST.DFSCD000) on the **INIT.PART** command for the first partition of the IMS catalog database:

```
IMSTEST.DFSCD000.DI1001
IMSTEST.DFSCD000.DI1002
IMSTEST.DFSCD000.BSDS
IMSTEST.DFSCD000.STG
```

To use a different data set name prefix for the IMS directory and its associated data sets, you can specify a high-level qualifier (HLQ) for them on the **SYSDSHLQ=** parameter in a dynamic allocation macro (DFSMDA) before you run the IMS Catalog Populate utility (DFS3PU00) to create them.

You can specify the **SYSDSHLQ=** parameter in a TYPE=CATDSHLQ statement in the DFSMDA macro.

After the IMS directory data sets are created, what you specify to access the directory data sets and where you specify it depends on how the HLQ was defined and what you need to do.

For example, if the HLQ for the IMS directory was defined by using the CATDSHLQ DFSMDA macro statement, when you run the IMS Catalog Library Builder utility (DFS3LU00), you can specify on the IMSCATHLQ= control statement either the HLQ of the directory data sets or the value of the DDNAME parameter in the CATDSHLQ DFSMDA macro. If both are specified, the utility checks for the DFSMDA member first.

Similarly, if you issue the OPEN call of the IMS Catalog API when the HLQ is defined by the CATDSHLQ DFSMDA macro, you can access the IMS directory by specifying the alias name of the IMS catalog on the CATALIAS= parameter.

Related reference

[“DFSMDA macro” on page 417](#)

Use the Dynamic Allocation macro (DFSMDA) to build a member (that is, one or more parameter lists) for naming data sets that can participate in dynamic allocation and deallocation. Members include databases, DEDBs, and data sets.

[“CATALOG and CATALOGxxxx sections of the DFSDFxxx member” on page 756](#)

The CATALOG and CATALOGxxxx sections contain options for an IMS catalog. The section headers must be specified as <SECTION=CATALOG> or <SECTION=CATALOGxxxx>. The CATALOG and CATALOGxxxx sections are valid in DB/DC, DBCTL, DCCTL and batch environments.

[IMS Catalog Definition exit routine \(DFS3CDX0\) \(Exit Routines\)](#)

Defining the IMS catalog master database and partitions

The IMS catalog is a HALDB (high availability large database) database that is a partitioned, IMS full-function database type (ACCESS=PHIDAM,OSAM) with OSAM utilizing Physical Sequential data sets or VSAM Linear Data Sets. Prior to loading records into an IMS catalog, you must define the partitions to IMS.

The HALDB partition definitions for the IMS catalog are typically registered in the RECON data set by DBRC. DBRC provides support for database recovery, data sharing, automatically generating JCL control statements, log and data set management, and other database tasks.

However, the IMS catalog is not required to register with DBRC. You can define the IMS catalog database partitions with the IMS catalog partition definition utility (DFS3UCD0) instead of using DBRC. The DFS3UCD0 utility stores the catalog partition information in the catalog partition definition data set. This option is not available for other HALDBs.

When the IMS catalog partition definition data set is used, the IMS catalog is not registered with DBRC. The database protection support provided by DBRC, including backup and recovery support, is unavailable to the IMS catalog when a IMS catalog partition definition data set is used. Some HALDB utilities are supported with restrictions for an unregistered IMS catalog database.

Additionally, the IMS catalog database does not support a HALDB Partition Selection exit routine in any configuration. The IMS catalog database always uses the high-key partition selection method.

Choose one of the following options.

Related concepts

[DBRC administration \(System Administration\)](#)

Related tasks

[“Setting up the IMS catalog” on page 249](#)

The following steps provide a high-level overview of setting up the IMS catalog for the first time.

[Using HALDB utilities with an unregistered IMS catalog \(Database Administration\)](#)

Related reference

[IMS Catalog Partition Definition Data Set utility \(DFS3UCD0\) \(System Utilities\)](#)

Defining the IMS catalog with DBRC

Use the Database Recovery Control utility (DSPURX00) to define the HALDB master database and partitions for the IMS catalog.

About this task

The following code is an example of the DBRC commands that are used to define an IMS catalog and its partitions, and the secondary index for the catalog, to DBRC:

```
//DEFCAT EXEC PGM=DSPURX00
//STEPLIB DD DSN=IMS.SDFSRESL,DISP=SHR
//SYSPRINT DD SYSOUT=*
//IMS DD DSN=IMS.DBDLIB,DISP=SHR
//SYSIN DD *
INIT.DB DBD(DFSCD000) TYPHALDB SHARELVL(3)
INIT.PART DBD(DFSCD000) PART(DFSCD01) -
  DSNPREFIX(IMSVS.IMEC.DFSCD000) -
  BLOCKSIZE(8192,8192,8192,8192) -
  KEYSTRNG('DBD ZZZZZZZ') -
  GENMAX(5)
INIT.PART DBD(DFSCD000) PART(DFSCP01) -
  DSNPREFIX(IMSVS.IMEC.DFSCD000) -
  BLOCKSIZE(8192,8192,8192,8192) -
  KEYSTRNG('PSB ZZZZZZZ') -
  GENMAX(5)
INIT.DB DBD(DFSCX000) TYPHALDB SHARELVL(3)
INIT.PART DBD(DFSCX000) PART(DFSCX01) -
  DSNPREFIX(IMSVS.IMEC.DFSCX000) GENMAX(3) -
  KEYSTRNG('X'FFFFFFFFFFFFFFFFFFFFFFFFFFFFFFFFFFFFFFFF)
```

```
LIST.DB DBD(DFSCD000) DBDS
LIST.DB DBD(DFSCX000) DBDS
```

The database and partition names must be coded as shown in the preceding example unless your IMS system uses a catalog alias prefix. In that case, replace *DFSC* with the four character alias prefix in the database and partition names for the catalog and the catalog secondary index. Alias prefixes are defined in the DFSDfxxx member of the IMS.PROCLIB data set. You can use multiple database definitions.

The root key for a catalog record is the value of the RHDRSEQ field in the HEADER segment of the catalog record. This key value is generated by the IMS catalog populate utility (DFS3PU00) or the ACB generation and catalog populate utility (DFS3UACB). The value is created by concatenating the record type and the IMS member name of the resource. The record type is eight characters long and is right-padded with blank characters. The IMS member name is always eight characters long.

For example, the following example shows the root key for a DBD record with the name ACF12000.

```
DBD      ACF12000
```

The following example shows the root key for a PSB record with the name MXG88888.

```
PSB      MXG88888
```

You can specify the key as a 16 character string, or as a 32 character hexadecimal binary representation of a 16 character string.

The root key value is also used to sort catalog records into database partitions, if your catalog database consists of more than one partition. The partition high key for the last partition in the database must be high enough to contain the highest-key record in the catalog.

If the IMS catalog has a secondary index that contains only a single partition, the DFS3PU00 and DFS3UACB utilities can allocate the data sets for the secondary index automatically. If the secondary index has more than a single partition, you must allocate the partition data sets yourself.

Related reference

[Database Recovery Control utility \(DSPURX00\) \(System Utilities\)](#)

[INIT.DB command \(Commands\)](#)

[INIT.PART command \(Commands\)](#)

Defining the IMS catalog without DBRC

The IMS catalog, unlike other HALDBs, can be defined without using DBRC.

About this task

The IMS catalog is a PHIDAM database. As a type of HALDB, PHIDAM databases cannot normally be used without enabling DBRC to manage the database partitions. However, the IMS catalog can be configured to run without using DBRC. This is called the *unregistered catalog* scenario because the partition definitions are not registered in the DBRC RECON data sets.

Recommendation: Use DBRC to manage the IMS catalog database partitions. Unregistered catalog databases are supported by some but not all HALDB utilities, and other restrictions apply. See [Using HALDB utilities with an unregistered IMS catalog \(Database Administration\)](#).

Procedure

1. Create a new DFSMDA member of the IMS.PROCLIB data set to dynamically allocate the catalog partition definition data set.

Modify the following JCL for your environment:

```
//DALOC    JOB
//*
//STEP     EXEC IMSDALOC
```



```
//SYSIN DD *
DFSMDA TYPE=INITIAL
DFSMDA TYPE=CATDBDEF,DSNAME=dsn
DFSMDA TYPE=FINAL
END
/*
```

The *dsn* value is the name of the new partition definition data set. See the [DFSMDA macro \(System Definition\)](#) topic for an explanation of each parameter.

2. Create the catalog database with the Catalog Partition Definition Data Set utility (DFS3UCD0).

The catalog partition definition data set is populated with the values specified with the HALDB and PART parameters of the utility.

```
//S1 EXEC PGM=DFS3UCD0,REGION=0M
//STEPLIB DD DSN=IMS.SDFSRESL,DISP=SHR
//DFSRESLB DD DSN=IMS.SDFSRESL,DISP=SHR
//DFSHDBSC DD DSN=...,DISP=
//SYSPRINT DD SYSOUT=*
//IMS DD DSN=IMS.DBDLIB,DISP=SHR
//SYSIN DD *
HALDB=(NAME=DFSCD000)
PART=(NAME=DFSCD000,PART=xxxxxxxx,
      DSNPREFIX=xxxxxxxx,
      KEYSTCHAR=xxxxxxxx)
/*
```

The name DFSCD000 in the HALDB and PART statements contains the default catalog prefix DFSC. If your catalog uses an alias name prefix, substitute it in the JCL.

The root key for a catalog record is the value of the RHDRSEQ field in the HEADER segment of the catalog record. This key value is generated by the IMS catalog populate utility (DFS3PU00) or the ACB generation and catalog populate utility (DFS3UACB). The value is created by concatenating the record type and the IMS member name of the resource. The record type is eight characters long and is right-padded with blank characters. The IMS member name is always eight characters long.

For example, the root key for a DBD record with the name ACF12000 is the following:

```
DBD ACF12000
```

The root key for a PSB record with the name MXG88888 is the following:

```
PSB MXG88888
```

The root key value is also used to sort catalog records into database partitions, if your catalog database consists of more than one partition. The partition high key for the last partition in the database must be high enough to contain the highest-key record in the catalog.

The catalog secondary index can have only one partition.

3. Identify the unregistered catalog database to IMS with the UNREGCATLG parameter in the DATABASE section of the DFSDFxxx member of the IMS.PROCLIB data set.

Modify the following sample section for your environment:

```
/* Database Section */
<SECTION=DATABASE>
UNREGCATLG=(DFSCD000,DFSCX000) /* Unregistered IMS catalog DB */
/*
```

Related concepts

[“Recovery-related EXEC parameters for the control region” on page 187](#)

The EXEC parameters that you can use to control the kind of recovery that is performed for the current system execution include DBRC=, DBRCNM=, QTU=, AND QTL=.

[Backup and recovery of the IMS catalog \(Database Administration\)](#)

Related reference

[“CATALOG and CATALOGxxxx sections of the DFSDFxxx member” on page 756](#)

The CATALOG and CATALOGxxxx sections contain options for an IMS catalog. The section headers must be specified as <SECTION=CATALOG> or <SECTION=CATALOGxxxx>. The CATALOG and CATALOGxxxx sections are valid in DB/DC, DBCTL, DCCTL and batch environments.

[“DFSMDA macro” on page 417](#)

Use the Dynamic Allocation macro (DFSMDA) to build a member (that is, one or more parameter lists) for naming data sets that can participate in dynamic allocation and deallocation. Members include databases, DEDBs, and data sets.

[“IMSDALOC procedure” on page 654](#)

Use the IMSDALOC procedure to generate the list of databases, DEDB data areas, and data sets that are to be dynamically allocated.

[IMS Catalog Partition Definition Data Set utility \(DFS3UCD0\) \(System Utilities\)](#)

Populating the IMS catalog by using IMS utilities

You can load or update the IMS catalog with the metadata about your database and program views by running either the IMS Catalog Populate utility (DFS3PU00) or the ACB Generation and Populate utility (DFS3UACB).

To populate the IMS catalog, these utilities read the metadata from one or more ACB libraries and insert the metadata into the IMS catalog. For some database types, the utilities also read metadata from DBD and PSB libraries.

The population utilities are also required to set up the IMS catalog to support the IMS management of ACBs. After the IMS management of ACBs is enabled, you can use either the population utilities or DDL to populate the IMS catalog and the population utilities can also be used to add the ACBs from an ACB library to the system-managed IMS directory data sets that are used by IMS to manage ACBs. When the population utilities are used to add ACBs to the IMS directory, the IMPORT DEFN SOURCE(CATALOG) command is usually required to complete the activation of the ACBs.

The IMS catalog is a HALDB PHIDAM database. When a population utility adds a database or program view to the IMS catalog for the first time, the utility creates a new database record for the database or program view metadata. The root header segment identifies the record as being for a database (DBD) or a program view (PSB).

When a utility updates the metadata for an existing database or program view, the utility adds the metadata by inserting a complete DBD or PSB segment instance hierarchy under the existing header segment of the record.

If you use the ACB Generation and Catalog Populate utility to populate the IMS catalog, the utility generates the ACB members from the DBD and PSB libraries directly and populates the IMS catalog in a single job step.

If you use the IMS Catalog Populate utility to populate the IMS catalog, the ACBs must be generated separately and provided to the utility as input. The DBD and PSB libraries are only conditionally required.

The utilities use IMS catalog PCBs to add records to the IMS catalog. IMS provides the PSBs that contain these PCBs.

You must specify a different PSB depending on the activity you are performing. The following activities are listed with the PSBs that they require:

- Performing an initial load of the IMS catalog: DFSCPL00
- Inserting records to an existing IMS catalog: DFSCP001
- Estimating the space requirements of the IMS catalog data sets: DFSCP000

You can also copy records from one IMS catalog to another by using the IMS Catalog Copy utility (DFS3CCI0, DFS3CCE0).

Related tasks

[Enabling IMS management of ACBs \(System Definition\)](#)

Related reference

[ACB Generation and Catalog Populate utility \(DFS3UACB\) \(System Utilities\)](#)

[IMS Catalog Populate utility \(DFS3PU00\) \(System Utilities\)](#)

[Application Control Blocks Maintenance utility \(DFSUACB0\) \(System Utilities\)](#)

[Database Description \(DBD\) Generation utility \(System Utilities\)](#)

[Program Specification Block \(PSB\) Generation utility \(System Utilities\)](#)

Input libraries required by the population utilities

ACB library members are always required to populate the IMS catalog by using the IMS Catalog Populate utility (DFS3PU00) or the ACB Generation and Populate utility (DFS3UACB). DBD and PSB library members are conditionally required.

The ACB library members can be contained in one or more IMS.ACBLIB data sets. If the ACB libraries contain PSBs that refer to logical databases, the utilities require information from the DBD library members in the IMS.DBDLIB data set. If the ACB libraries contain PSBs that refer to GSAM databases, the utilities require information from both the DBD and PSB libraries in the IMS.DBDLIB and the IMS.PSBLIB data sets.

The utility that populates the IMS catalog must be from the same version of IMS as the utility that generated the input ACB members.

The JCL for the DFS3PU00 utility must refer to the appropriate PSBLIBs and DBDLIBs in the IMS ddname.

Unavailability of required DBD or PSB members

If a PSB member that is in your ACB library refers to a GSAM database and either that PSB is not in your PSB library or the referenced GSAM DBD is not in your DBD library, the PSB record is not inserted in the catalog. Similarly, if a PSB member that is in your ACB library refers to a logical database and the logical DBD is not in your DBD library, the PSB record is not inserted in the catalog. In either of these cases, if the PSB member in your ACB library also refers to databases that are neither GSAM nor logical databases, then catalog records for those databases are inserted in the catalog, as long as those databases have members in your ACB library.

You can add the missing catalog records later by supplying the necessary PSB or DBD library and running the utility with the insert-mode catalog PSB DFSCP001 and the same ACB library.

A DBD catalog record is created for a referenced GSAM database only if a PSB catalog record is created for a PSB that refers to both a GSAM database and a non-GSAM database. If a PSB refers only to GSAM databases, no PSB catalog record is created for the PSB.

Multiple input ACB libraries

You can include multiple ACB libraries as input to the utilities that populate the IMS catalog. The data sets for the input ACB libraries can be specified in separate ddnames, in a concatenation for a single ddname, or using a combination of these.

The first or only ddname that you use to specify an ACB library must be IMSACB01. Each additional ddname that you use to specify an ACB library must be IMSACB nn , where nn is the number from the previous ACB library ddname incremented by one. For example, if you use three ddnames, they must be specified in order as IMSACB01, IMSACB02, and IMSACB03.

When duplicate ACB members are encountered, the duplicates are not processed. The DFS3PU00 utility considers ACB members to be duplicates of each other if both their ACB member names and timestamps are identical. The DFS3PU00 utility does not load data into the catalog from an ACB member that is either a duplicate of another ACB member read as input from another ACB library or of an ACB member from which data has previously been loaded into the IMS catalog. If an input ACB member has the same name

as a previously read ACB member, but has a different timestamp, the data from both ACB members is loaded into the IMS catalog.

Note: When the input data sets for multiple ACB libraries are concatenated in a single DD statement, ACB members that have the same member name as a member from a data set earlier in the concatenation are completely ignored, even if the timestamps are different. Only the first instance of an ACB member with a given name in the list of concatenated data sets is passed to the utility as input. Consequently, if you need to load the data from ACB members that have the same name but different timestamps into the IMS catalog, specify the applicable ACB libraries by using separate DD statements.

DFSDFxxx member of the IMS.PROCLIB data set

The IMS Catalog Populate utility (DFS3PU00) or the ACB Generation and Populate utility (DFS3UACB) reads the <CATALOG> section of the DFSDFxxx member in the IMS.PROCLIB data set.

Before populating the IMS catalog, the catalog section must be coded correctly for the IMS catalog. The DFSDFxxx member must be referenced in the execution parameters in the JCL for the utilities that populate the IMS catalog.

Requirement: The IMS Catalog Populate utility and the ACB Generation and Catalog Populate utility require the <CATALOG> section heading at the beginning of the section for the catalog parameters in the DFSDFxxx member. The utilities do not support the <CATALOGxxxx> heading. The <CATALOGxxxx> heading is used when multiple IMS systems share a DFSDFxxx member, but do not share the IMS catalog.

The DFSDFxxx member that the utilities use is specified in the utility JCL. For example, in the following JCL, 'DFSDF=001' specifies the DFSDF001 member of the PROCLIB data set:

```
//LOADCAT EXEC PGM=DFS3PU00,  
// PARM=(DLI,DFS3PU00,DFSCPL00,,,,,,,,,,,,,Y,N,,,,,,,,,,,,,'DFSDF=001')
```

Related reference

[“CATALOG and CATALOGxxxx sections of the DFSDFxxx member” on page 756](#)

The CATALOG and CATALOGxxxx sections contain options for an IMS catalog. The section headers must be specified as <SECTION=CATALOG> or <SECTION=CATALOGxxxx>. The CATALOG and CATALOGxxxx sections are valid in DB/DC, DBCTL, DCCTL and batch environments.

Access type and the population utilities in a multi-system environment

When the IMS catalog is shared by multiple systems, you can add records to the catalog by executing the utility that populates the catalog as a DL/I batch job, otherwise you can execute the utility as a BMP job.

If the utility is run as a BMP, the type of database access that the IMS catalog database allows might need to be changed. By default the IMS catalog allows only read access. To load or update the IMS catalog in BMP mode, the IMS catalog database must be changed to allow update access.

You can set the default access type for the IMS catalog by specifying the ACCESS= parameter in the CATALOG section of the DFSDFxxx member. Unless the IMS management of ACBs is enabled, the default access type for the IMS catalog is ACCESS=READ. When IMS manages ACBs, the default access type is ACCESS=UPDATE.

The access type that the IMS catalog database allows can be changed by either of the following commands:

- **UPDATE DB** NAME(DFSCD000,DFSCX000) START(ACCESS) SET(ACCTYPE=UPD)
- **/START DB** DFSCD000 DFSCX000 ACCESS=UP

Populating the IMS catalog using the ACB Generation and Catalog Populate utility (DFS3UACB)

You can generate ACB members and populate the IMS catalog in a single step by using the ACB Generation and Catalog Populate utility (DFS3UACB).

About this task

To support the IMS management of ACBs function, the DFS3UACB utility can also be used to set up the IMS catalog to manage ACBs and to load the ACBs into system data sets for activation in the IMS system. Whether the utility sets up or loads IMS-managed ACBs into the IMS system is controlled by the `MANAGEDACBS=` statement in the utility `SYSINP` DD statement.

The DFS3UACB utility can be used to generate an entire ACB library and perform an initial load of an IMS catalog or to generate specific ACB members and add the corresponding records to an existing IMS catalog.

To generate the ACB members, the DFS3UACB makes an internal call to the ACB Maintenance utility. The DFS3UACB utility accepts all of the same control statements as the ACB Maintenance utility. Error messages issued during the ACB generation phase can come from either the DFS3UACB utility or the ACB Maintenance utility. For the ACB generation phase of the utility execution, the operation requirements are the same as those of the ACB Maintenance utility.

Similarly, to load or update the IMS catalog, the DFS3UACB utility makes an internal call to the IMS Catalog Populate utility (DFS3PU00). Consequently, any error messages that are issued during the population phase can come from either the DFS3UACB utility or the DFS3PU00 utility.

The DFS3UACB utility requires access to the `DFSDFxxx` member of the `IMS.PROCLIB` data set. Specify the `DFSDFxxx` member in the utility `JCL`.

Requirement: The catalog parameters in the `DFSDFxxx` member are specified in a catalog section. For the purpose of populating the IMS catalog, you must identify the start of the catalog section in a `DFSDFxxx` member by using the heading `<CATALOG>`. The IMS Catalog Populate utility (DFS3PU00) and the ACB Generation and Catalog Populate utility (DFS3UACB) do not support the `<CATALOGxxxx>` heading. The `<CATALOGxxxx>` heading is used when multiple IMS systems share a `DFSDFxxx` member, but do not share IMS catalogs.

An optional `ACBCATWK` data set can be used to greatly improve the performance of the population phase of the DFS3UACB utility. The DFS3UACB utility records the ACB members generated in the `ACBCATWK` data set, which eliminates the need to read the ACB library during the population phase to determine which IMS catalog records need to be created or updated.

When the DFS3UACB utility populates the IMS catalog, the utility stores the ACB members in the `IMS.ACBLIB` data set and internally calls the IMS Catalog Populate utility (DFS3PU00) to load or update the records in the IMS catalog in the same unit of work (UOW).

Related reference

[ACB Generation and Catalog Populate utility \(DFS3UACB\) \(System Utilities\)](#)

[Application Control Blocks Maintenance utility \(DFSUACB0\) \(System Utilities\)](#)

[IMS Catalog Populate utility \(DFS3PU00\) \(System Utilities\)](#)

[Database Description \(DBD\) Generation utility \(System Utilities\)](#)

[Program Specification Block \(PSB\) Generation utility \(System Utilities\)](#)

Loading the IMS catalog with the DFS3UACB utility

In IMS systems that use ACB libraries to manage the runtime application control blocks, you can generate ACB members for your databases and application programs and perform an initial load of the IMS catalog

with the ACB Generation and Catalog Populate utility (DFS3UACB) by specifying the PSB DFSCPL00 in the utility JCL.

About this task



Attention: When the DFSCPL00 PSB is specified in the DFS3UACB utility JCL, the DFS3UACB utility deletes all existing records in the IMS catalog before populating the IMS catalog in load mode.

The DFS3UACB utility generates the ACB library members and loads the IMS catalog in the same job step.

Internally, the DFS3UACB utility calls the ACB Maintenance utility to generate the ACB members. After the ACB generation phase is complete, the DFS3UACB utility calls the IMS Catalog Populate utility (DFS3PU00) to load the IMS catalog.

To generate the ACB members, you specify ACB generation control statements by using the SYSIN DD statement in the utility JCL. For example:

```
//SYSIN DD *  
BUILD PSB=ALL
```

To load the IMS catalog, you must specify the load PSB for the IMS catalog, DFSCPL00, in the execution parameters that the DFS3UACB utility passes to the DFS3PU00 utility. The execution parameters for the DFS3PU00 utility must be specified by using the DFS3PPRM DD statement in the DFS3UACB JCL. For example:

```
//DFS3PPRM DD *  
DLI,DFS3PU00,DFSCPL00,,,,,,,,,Y,N,,,,,,,,,DFSDF=CAT
```

The utility JCL for the DFS3UACB utility must reference a DFSDFxxx member in the IMS.PROCLIB data set. In the preceding example, the DFS3UACB utility referenced a DFSDFxxx member called DFSDFCAT, as indicated by DFSDF=CAT. The utility references only the catalog section of the DF member, not an IMS specific section.

The execution parameters referenced by the DFS3PPRM DD statement override the default parameters that are used by the DFS3PU00 utility.

Because the DFS3UACB utility calls both the ACB Maintenance utility and the DFS3PU00 utility, all of the restrictions, requirements, prerequisites, and so forth, that apply to these two utilities also apply to the DFS3UACB utility.

Recommendation: Specify a work data set for the DFS3UACB utility to record the ACB members that are generated. Specifying the work data set improves the performance of the populate phase of the job step. The work data set is referenced in the DFS3UACB utility JCL by the ACBCATWK DD statement.

Related reference

[ACB Generation and Catalog Populate utility \(DFS3UACB\) \(System Utilities\)](#)

[Application Control Blocks Maintenance utility \(DFSUACB0\) \(System Utilities\)](#)

[IMS Catalog Populate utility \(DFS3PU00\) \(System Utilities\)](#)

[Database Description \(DBD\) Generation utility \(System Utilities\)](#)

[Program Specification Block \(PSB\) Generation utility \(System Utilities\)](#)

Adding records to the IMS catalog with the DFS3UACB utility

If you are adding new or changed ACB members to an ACB library, you can add the corresponding new or changed IMS catalog records to an existing IMS catalog in the same job step by using the ACB Generation and Catalog Populate utility (DFS3UACB).

About this task

This task applies only for IMS systems that use an ACB library.

The DFS3UACB utility calls the ACB Maintenance utility to generate the ACB members. After generating the ACB members and loading them into the IMS.ACBLIB data set, the DFS3UACB utility calls the IMS Catalog Populate utility (DFS3PU00).

Recommendation: To improve the performance of the population of the IMS catalog, specify a work data set for the DFS3UACB utility with the ACBCATWK DD statement. During the ACB generation phase, the ACB members that are generated are listed in the work data set. During the populate phase, the work data set is read as input, which significantly reduces the time required to update the IMS catalog.

For backout and recovery purposes, IMS logs all changes to the catalog and, if the IMS catalog is registered with DBRC, records these logs in the RECON data set. Save the logs for recovery purposes.

When adding records to the IMS catalog, the JCL for the utility must specify the IMS-provided PSB DFSCP001, which includes a PCB that is defined with PROCOPT=A.

```
DLI,DFS3PU00,DFSCP001,,,,,,,,,,,,,Y,N,,,,,,,,,,,,,DFSDF=CAT
```

The N in the preceding example indicates that IRLM is not used and, therefore, data sharing is not enabled for the IMS catalog that is being updated. If IRLM is active for the IMS catalog that is being updated, you must change the N to a Y.

Related reference

[ACB Generation and Catalog Populate utility \(DFS3UACB\) \(System Utilities\)](#)

[Application Control Blocks Maintenance utility \(DFSUACB0\) \(System Utilities\)](#)

[IMS Catalog Populate utility \(DFS3PU00\) \(System Utilities\)](#)

[Database Description \(DBD\) Generation utility \(System Utilities\)](#)

[Program Specification Block \(PSB\) Generation utility \(System Utilities\)](#)

Populating the IMS catalog using the IMS Catalog Populate utility (DFS3PU00)

Use the IMS Catalog Populate utility (DFS3PU00) to perform an initial load of an IMS catalog, to update an IMS catalog, or to set up an IMS catalog for the IMS management of ACBs.

About this task

The DFS3PU00 utility requires access to the DFSDFxxx member of the IMS.PROCLIB data set. Attributes of the IMS catalog are defined by parameters in the <CATALOG> section of the DFSDFxxx member. Specify the DFSDFxxx member in the utility JCL.

Requirement: The DFS3PU00 utility requires that the section header for the catalog section in the DFSDFxxx member be specified as <CATALOG>. The DFS3PU00 utility does not support the <CATALOGxxxx> heading. The <CATALOGxxxx> heading is used when multiple IMS systems share a DFSDFxxx member, but do not share IMS catalogs.

Note: Do not run the DFS3PU00 utility as a BMP with MANAGEDACBS=SETUP specified when ACBLIBs are used to manage ACBs, which is specified by ACBMGMT=ACBLIB.

Related reference

[IMS Catalog Populate utility \(DFS3PU00\) \(System Utilities\)](#)

[Application Control Blocks Maintenance utility \(DFSUACB0\) \(System Utilities\)](#)

[Database Description \(DBD\) Generation utility \(System Utilities\)](#)

[Program Specification Block \(PSB\) Generation utility \(System Utilities\)](#)

Loading the IMS catalog with the DFS3PU00 utility

You can perform an initial load of the IMS catalog by using the IMS Catalog Populate utility (DFS3PU00).

Before you begin

Prerequisites:

- If you have not already done so, enable the IMS catalog database by generating the DBDs, PSBs, and ACBs of the IMS catalog database.
- Define the IMS catalog HALDB master database and partitions either in the RECON data set or the IMS catalog partition definition data set.
- Complete all DBD, PSB, and ACB generation processes for the user databases and application programs at your IMS installation.
- For GSAM databases, you must also provide both the DBD library and the PSB library that were used to generate the members in the ACB library.
- For logical databases, you must also provide either the DBD library that was used to generate the members in the ACB library.

About this task

The DFS3PU00 utility loads the IMS catalog by using the IMS-provided PSB DFSCPL00, which includes a PCB defined with PROCOPT=L. For example:

```
//UPDTCAT EXEC PGM=DFS3PU00,  
//                PARM=(DLI,DFS3PU00,DFSCPL00,,,,,,,,,Y,N,,,,,,,,, 'DFSDF=001')
```

Running the DFS3PU00 utility with the PSB DFSCPL00 deletes any existing records in the IMS catalog.

If you are also enabling the IMS management of ACBs, which is required for IMS support for SQL DDL processing, specify the MANAGEDACBS=SETUP control statement in the SYSINP DD statement in the utility JCL.

For an example of the complete utility JCL, see the IMS Catalog Populate utility documentation.

After the IMS catalog is loaded, enable the IMS catalog by specifying CATALOG=Y in the <CATALOG> section of the DFSDFxxx member in the IMS.PROCLIB data set.

For more information about setting up an IMS catalog, see [“Setting up the IMS catalog” on page 249](#).

Related reference

[IMS Catalog Populate utility \(DFS3PU00\) \(System Utilities\)](#)

[Application Control Blocks Maintenance utility \(DFSUACB0\) \(System Utilities\)](#)

[Database Description \(DBD\) Generation utility \(System Utilities\)](#)

[Program Specification Block \(PSB\) Generation utility \(System Utilities\)](#)

Adding records to the IMS catalog with the DFS3PU00 utility

You can add additional records to an existing IMS catalog from one or more ACB library data sets of IMS systems by using the IMS Catalog Populate utility (DFS3PU00).

Before you begin

Prerequisites:

- Prior to running the DFS3PU00 utility to add records to an IMS catalog, the ACB members for any new or changed DBDs or PSBs must be generated by the ACB Maintenance utility.
- To add metadata to the IMS catalog for GSAM databases, in addition to the ACB library, you must also provide both the DBD library and the PSB library that were used to generate the members in the ACB library.

- To add metadata to the IMS catalog for logical databases, in addition to the ACB library, you must also provide the DBD library that was used to generate the members in the ACB library.

About this task

If the IMS catalog is shared among IMS systems, you can add records to the catalog using a DL/I batch job even when the catalog is authorized by an online IMS system. If the IMS catalog is not shared, you can add records to the catalog by running the DFS3PU00 utility as a batch message processing (BMP) job in the IMS system that the catalog supports.

If the IMS management of ACBs is enabled by ACBGMT=CATALOG in the <CATALOG> section of the DFSDFxxx PROCLIB member, the DFS3PU00 utility also copies the input ACBs to either the catalog staging data set or the IMS directory data set, depending on the specification of the MANAGEDACBS= control statement. If MANAGEDACBS=UPDATE is specified, IMS must be shut down while the DFS3PU00 utility adds the ACBs to the IMS directory directly and the ACBs are activated when IMS restarts. If MANAGEDACBS=STAGE is specified, the DFS3PU00 utility adds the ACBs to the staging data set of the IMS directory. The ACBs in the staging data sets are not activated until the **IMPORT DEFN SOURCE (CATALOG)** is specified.

For backout and recovery purposes, IMS logs all changes to the catalog and, if the IMS catalog is registered with DBRC, records these logs in the RECON data set. Save the logs for recovery purposes.

When adding records to the IMS catalog, the JCL for the utility must specify the IMS-provided PSB DFSCP001, which includes a PCB defined with PROCOPT=A. For example:

```
//UPDTCAT EXEC PGM=DFS3PU00,
//                PARM=(DLI,DFS3PU00,DFSCP001,,,,,,,,,Y,N,,,,,,,,, 'DFSDF=001')
```

The N in the preceding example indicates that IRLM is not used and, therefore, data sharing is not enabled for the IMS catalog that is being updated. If IRLM is active for the IMS catalog that is being updated, you must change the N to a Y and add the IRLM ID in the following position.

For an example of the complete utility JCL, click the following link to the IMS Catalog Populate utility documentation.

Related reference

[IMS Catalog Populate utility \(DFS3PU00\) \(System Utilities\)](#)

[Application Control Blocks Maintenance utility \(DFSUACB0\) \(System Utilities\)](#)

[Database Description \(DBD\) Generation utility \(System Utilities\)](#)

[Program Specification Block \(PSB\) Generation utility \(System Utilities\)](#)

Keeping the IMS catalog in sync with the active ACB library

In IMS systems that use an ACB library, you must ensure that the IMS catalog includes metadata that matches the members in the active ACB library.

In IMS systems that manage ACBs, the IMS catalog stores the active ACBs, so it always contains the matching metadata.

Each time you update the metadata for a DBD or PSB in the IMS catalog, IMS preserves the previous copy of the metadata, so a record in the IMS catalog can contain many different copies of the metadata for the DBD or PSB. Only the copy of the metadata that matches either the active ACB member or, in some cases, the DBD member, is the current metadata.

The metadata in the IMS catalog is usually accessed by directly or indirectly issuing the DL/I GUR call, which determines which copy of the metadata is current by checking the timestamp of the ACB member that is in the active ACB library. Only the copy of the DBD or PSB metadata with the matching timestamp is returned.

For databases that have metadata that is not stored in the ACB library, such as a GSAM or logically related database, the GUR call checks the scheduled PSB for the timestamp of the DBD member. If the PSB does

not reference the database then no metadata is returned and the GUR call fails with a non-zero return code and a reason code in the AIB.

Recommendation: Only the GUR call checks the timestamps. Do not use any other DL/I call to directly access the metadata in the IMS catalog.

Determining which copy of the metadata is current is critical because the most recent copy of the metadata in the IMS catalog is frequently not the copy that matches the active ACB library members that application programs are currently using.

For example, if you generate your ACB members into an inactive ACB library and update the corresponding metadata in the IMS catalog before activating the ACB members, the most recent copy of the metadata in the IMS catalog is not the current metadata. The most recent metadata in the IMS catalog will not be current until you activate the ACB members.

The following figure shows an example of the scenario described in the preceding paragraph. In the figure, DB1, DB2®, and DB3 are the names of DBDs. TS0 and TS1 represent timestamps. The ACB member for DB3 was regenerated into the inactive ACB library and now has a new timestamp, TS1. The metadata in the IMS catalog was also updated, so the most recent version of the metadata in the IMS catalog also has a timestamp of TS1. Online Change (OLC) has not been performed yet, so the DB3 member in the ACB library and the DB3 DMB still have a timestamp of TS0.

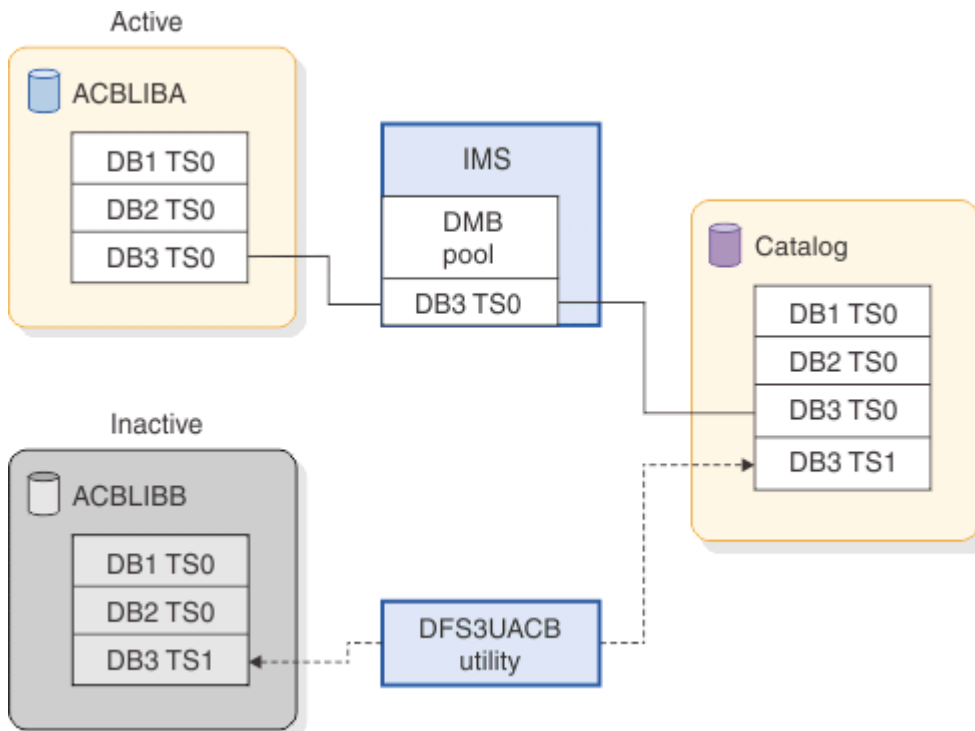

In the following figure, OLC was performed. The ACB library that contains the ACB member with timestamp TS1 is now active and the timestamp on the DB3 DMB is now also TS1. The metadata in the IMS catalog is now current with the ACB member that is being used in the online IMS system.

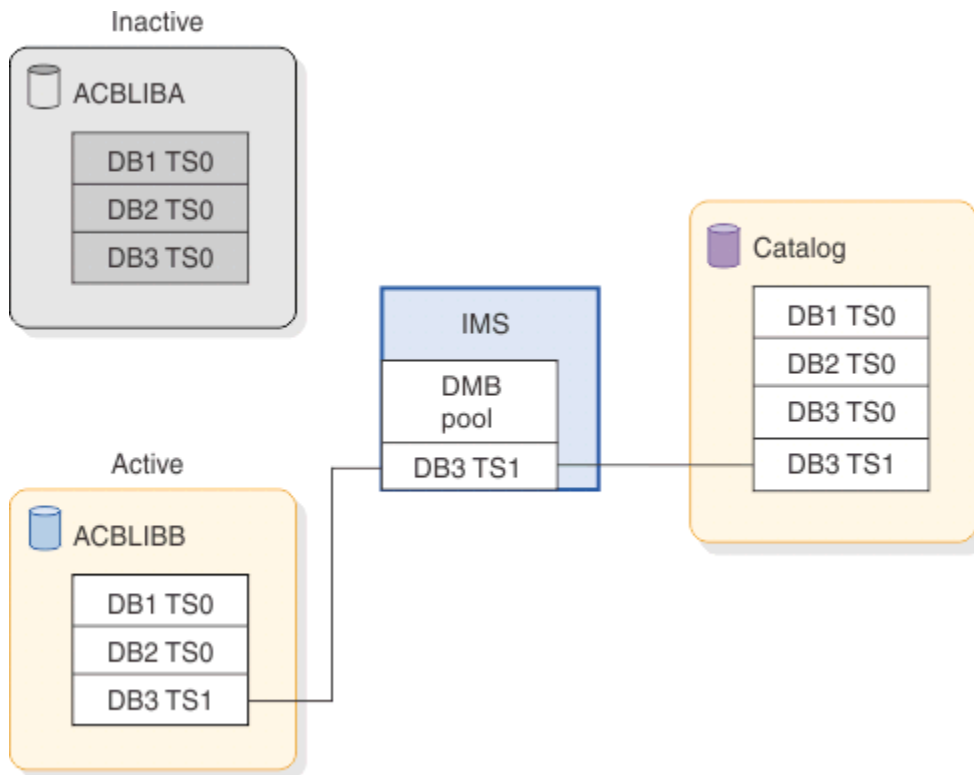

Another scenario in which the metadata in the IMS catalog might not match the corresponding ACB members in the active ACB library is if the ACB members are generated and activated, but the corresponding metadata was not updated in the IMS catalog. In this case, IMS returns an AIB return and reason code to inform the application program that the metadata for the active ACB member was not found in the IMS catalog.

The IMS catalog in multi-system configurations

In a multi-system environment, all of the IMS systems can share a single IMS catalog, each IMS system can have its own IMS catalog, or some IMS systems can share while and other systems can have their own.

Similarly, the resources that are associated with the IMS catalog, such as ACB libraries and DFSDFxxx members of the IMS.PROCLIB data set, can be shared by some IMS systems, all IMS systems, or no IMS systems.

To share an IMS catalog, DBRC and the configuration of a data sharing environment is required.

Recommendation: If your IMS systems share databases, have them share an IMS catalog as well. Keeping common metadata in sync across independent IMS catalogs can be difficult and is prone to error. Sharing reduces complexity.

When the IMS management of ACBs is enabled for an IMS system, the IMS catalog assumes the role of the ACB library for that system. The system no longer uses ACB, DBD, and PSB libraries. The sharing of ACBs is determined by the sharing of the IMS catalog and the specification of the ACBSHR parameter in the DFSCGxxx member or in the COMMON_SERVICE_LAYER section of the DFSDFxxx member of the PROCLIB data set. If an IMS system requires a different set of ACBs than other IMS systems in a multi-system environment, the IMS system must use its own IMS catalog.

Each IMS catalog must have an alias name. The alias name is specified in the DFSDFxxx member on the ALIAS parameter. If you use multiple IMS catalogs, each alias name must be different. If you use only a single IMS catalog and do not need to use an alias name, specify the default catalog prefix, DFSC, as the alias name.

If the RECON data sets are shared, but IMS catalogs are not shared, when the IMS catalog databases are registered with DBRC, they must be defined in the RECON data set by using their alias names. The alias

name dynamically replaces the first four characters of the catalog database name and secondary index name and prevents conflicts in a multi-system environment.

Related concepts

[Data sharing in IMS environments \(System Administration\)](#)

[Supporting data sharing \(System Administration\)](#)

[DBRC groups \(System Administration\)](#)

Related reference

[“CATALOG and CATALOGxxxx sections of the DFSDFXxx member” on page 756](#)

The CATALOG and CATALOGxxxx sections contain options for an IMS catalog. The section headers must be specified as <SECTION=CATALOG> or <SECTION=CATALOGxxxx>. The CATALOG and CATALOGxxxx sections are valid in DB/DC, DBCTL, DCCTL and batch environments.

Sharing an IMS catalog

As an IMS HALDB database, the IMS catalog can be shared among multiple IMS systems in a data sharing environment.

About this task

When the IMS management of ACBs is enabled, sharing an IMS catalog greatly simplifies the coordination of changes to shared databases and program views across all of the IMS systems that use those resources. After the changes are submitted to IMS, either via DDL statements or via one of the IMS catalog population utilities, the changes are activated in the online IMS systems either automatically or by issuing the IMPORT DEFN SOURCE(CATALOG) command. If the IMS catalog is not shared, the changes need to be applied to each sharing IMS system independently and IMS does not coordinate the activation of the changed resources across the data sharing group.

To share an IMS catalog, you must configure your data sharing environment as you would for any shared IMS database.

You can share the IMS catalog and directory data sets with a DCCTL system in a sysplex environment so that the DCCTL system can use the IMS management of ACBs enhancement. To enable IMS management of ACBs in a DCCTL system, specify ACBMGMT=CATALOG in the CATALOG or CATALOGxxxx section of the DFSDFXxx member of the DCCTL IMS instance.

The IMS catalog and directory must be created and maintained by a non-DCCTL IMS in the sysplex. The DCCTL system cannot create or maintain the IMS catalog or the directory data sets.

Additionally, sharing an IMS catalog requires the following specific actions.

Procedure

- Configure the IMS catalog to use DBRC.
DBRC is required for data sharing of the IMS catalog by application programs and utilities that are running in either online IMS dependent regions or in batch regions.
- Register the IMS catalog database in the RECON data set with a share level of 2 or 3.
You can specify the share level either by using the DBRC commands **INIT . DB** or **CHANGE . DB** or by using the TSO HALDB Partition Definition utility (%DFSHALDB). The share level applies to the HALDB master database and all of the partitions that it contains.
- For recovery purposes, register the IMS catalog database data sets as members of a new or existing change accumulation group in DBRC, as described in [Change accumulation groups \(System Administration\)](#).
- Specify a SHAREOPTIONS value of (1,3), (2,3), or (3,3) when you define the VSAM data sets of the IMS catalog.
The primary index, secondary index, and indirect list data set (ILDS) of the IMS catalog use VSAM.

- If application programs or utilities in multiple IMS systems must update a shared IMS catalog concurrently, change the access of the IMS catalog to update by using one of the following commands:
 - **UPDATE DB** NAME(DFSCD000,DFSCX000) START(ACCESS) SET(ACCTYPE=UPD)
 - **START DB** DFSCD000 DFSCX000 ACCESS=UP
- Enable IRLM support in the JCL of the application programs and utilities that access the shared IMS catalog by specifying Y and the IRLM ID in the execution parameters. For example, the second Y and *irlmid* values in following execution parameters for the IMS Catalog Populate utility (DFS3PU00) specify IRLM support:

```
PARM=(DLI,DFS3PU00,DFSCP001,,,,,,,,,,,,,Y,Y,irlmid,,,,,,,,,,,,,'DFSDF=001')
```

Related concepts

[Data sharing in IMS environments \(System Administration\)](#)

[Coordinating VSAM data set definitions with share options \(System Administration\)](#)

[Supporting data sharing \(System Administration\)](#)

DFSDFxxx members and the IMS catalog in multi-system configurations

In a multi-system environment, you can define one or more IMS catalogs in a DFSDFxxx member.

When only a single IMS catalog is defined in a DFSDFxxx member, the attributes of the IMS catalog are specified in a single section after the section header <SECTION=CATALOG>. All IMS systems that use that DFSDFxxx member use that IMS catalog.

When multiple IMS catalogs are defined in a DFSDFxxx member, each IMS catalog is defined in a separate section. Each section is uniquely identified in the DFSDFxxx member by appending an IMS ID to CATALOG in the section header. For example, <SECTION=CATALOGIMS1>. The IMS ID also determines which IMS system uses the IMS catalog that is defined in that section.

Related concepts

[Data sharing in IMS environments \(System Administration\)](#)

[Supporting data sharing \(System Administration\)](#)

[DBRC groups \(System Administration\)](#)

Related reference

[“CATALOG and CATALOGxxxx sections of the DFSDFxxx member” on page 756](#)

The CATALOG and CATALOGxxxx sections contain options for an IMS catalog. The section headers must be specified as <SECTION=CATALOG> or <SECTION=CATALOGxxxx>. The CATALOG and CATALOGxxxx sections are valid in DB/DC, DBCTL, DCCTL and batch environments.

Defining an IMS catalog alias name

When your IMS environment includes multiple IMS catalog databases, you differentiate between the IMS catalogs by assigning unique alias names to the IMS catalogs when they are first defined.

About this task

To support environments that require more than one IMS catalog, IMS can perform dynamic IMS catalog name aliasing on behalf of your application programs.

You do not need to make any modifications to your user PCBs, which always refer to the catalog database as DFSCD000 and the catalog secondary index as DFSCX000.

Alias names are not needed in a configuration where multiple IMS systems in an IMSplex can share a single IMS catalog that contains the metadata for the entire environment. In this configuration, every IMS system can use the standard catalog database name, DFSCD000, and the standard catalog secondary index name, DFSCX000.

The procedure for assigning an alias name to an IMS catalog is the same regardless of whether you intend to enable the IMS management of ACBs or you intend to manage your ACBs by using ACB libraries. If you

are going to enable the IMS management of ACBs, even though the IMS system will not use ACB, DBD, and PSB libraries, you still must allocate and use DBD, PSB, and ACB libraries temporarily to enable the IMS catalog and assign the alias name.

Procedure

1. Create or modify the DFSDFxxx member of the IMS.PROCLIB data set with a <SECTION=CATALOG> or <SECTION=CATALOGxxxx> statement.

Include the ALIAS parameter with a valid, 4-character prefix other than DFSC.

2. Add alias names to the IMS catalog database name list in your IMS DBD library with the IMS Catalog Alias Names utility (DFS3ALIO).

Modify the following utility JCL for your environment:

```
//ALIAS EXEC PGM=DFS3ALIO
//STEPLIB DD DSN=IMS.SDFSRESL,DISP=SHR
//DFSRESLB DD DSN=IMS.SDFSRESL,DISP=SHR
//SYSPRINT DD SYSOUT=*
//SYSLMOD DD DSN=IMS.DBDLIB,DISP=OLD
//SYSLIN DD UNIT=SYSDA,SPACE=(CYL,(1,1))
//SYSUT1 DD UNIT=SYSDA,SPACE=(CYL,(1,1))
//SYSIN DD *
prefix1,prefix2,...
/*
```

3. Define the new IMS catalog database in the RECON data set by using the Database Recovery Control utility (DSPURX00).

Modify the following utility JCL for your environment. This example uses the alias name IMS1:

```
//ALIAS1 EXEC PGM=DSPURX00
//STEPLIB DD DSN=IMS.SDFSRESL,DISP=SHR
//SYSPRINT DD SYSOUT=*
//IMS DD DSN=IMS.DBDLIB,DISP=SHR
//SYSIN DD *
INIT.DB DBD(IMS1D000) TYPHALDB SHARELVL(3)
INIT.PART DBD(IMS1D000) PART(IMS1D01) -
  DSNPREFIX(dsnprefix.IMS1D000) -
  BLOCKSIZE(4096) -
  KEYSTRNG(X'FFFFFFFFFFFFFFFFFFFFFFFF')
INIT.DB DBD(IMS1X000) TYPHALDB SHARELVL(3)
INIT.PART DBD(IMS1X000) PART(IMS1X01) -
  DSNPREFIX(dsnprefix.IMS1X000) -
  KEYSTRNG(X'FFFFFFFFFFFFFFFFFFFFFFFF')
/*
```

4. Add ACB library metadata to the IMS catalog database with the IMS Catalog Populate utility (DFS3PU00).

The utility JCL must refer to the DFSDFxxx member that defines the alias name for the catalog.

Related reference

[“CATALOG and CATALOGxxxx sections of the DFSDFxxx member” on page 756](#)

The CATALOG and CATALOGxxxx sections contain options for an IMS catalog. The section headers must be specified as <SECTION=CATALOG> or <SECTION=CATALOGxxxx>. The CATALOG and CATALOGxxxx sections are valid in DB/DC, DBCTL, DCCTL and batch environments.

[IMS Catalog Alias Names utility \(DFS3ALIO\) \(System Utilities\)](#)

IMS catalog multi-system configuration examples

The following figures show some of the multi-system configurations that are possible with the IMS catalog.

Multiple IMS systems with one IMS catalog

In the following example, all of the IMS systems in a multi-system environment share a single catalog database. The attributes of the IMS catalog are defined in a single <CATALOG> section of a single DFSDFxxx member that all of the IMS systems reference. The systems also share ACB library data sets.

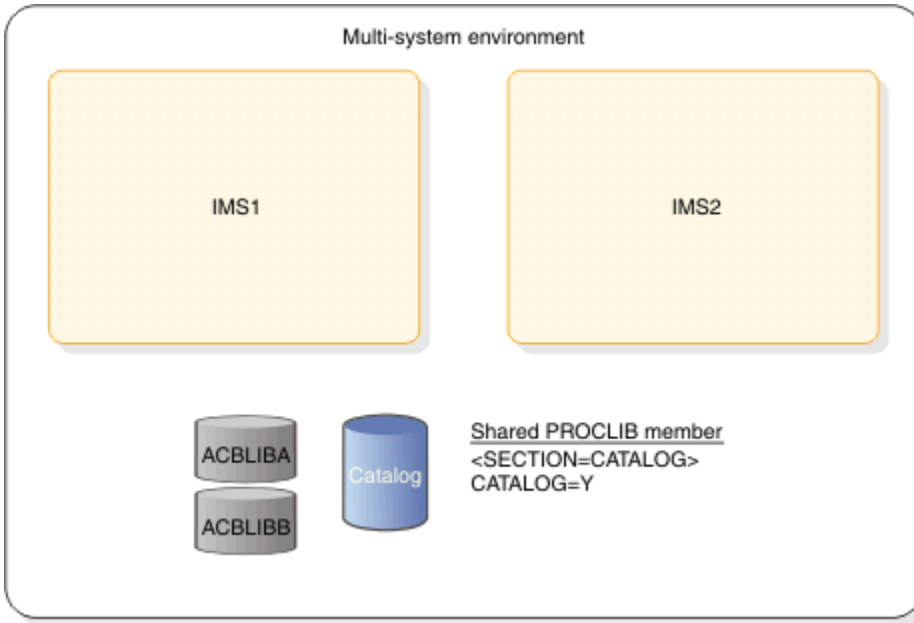

Figure 14. Two IMS systems with a shared catalog database

Multiple IMS systems with one IMS catalog and IMS-managed ACBs

In the following example, all of the IMS systems in a multi-system environment share a single catalog database. The IMS management of ACBs is enabled for both IMS systems by a specification of ACBMGMT=CATALOG in the <CATALOG> section of a single DFSDFxxx member that all of the IMS systems reference. ACB library data sets are not used.

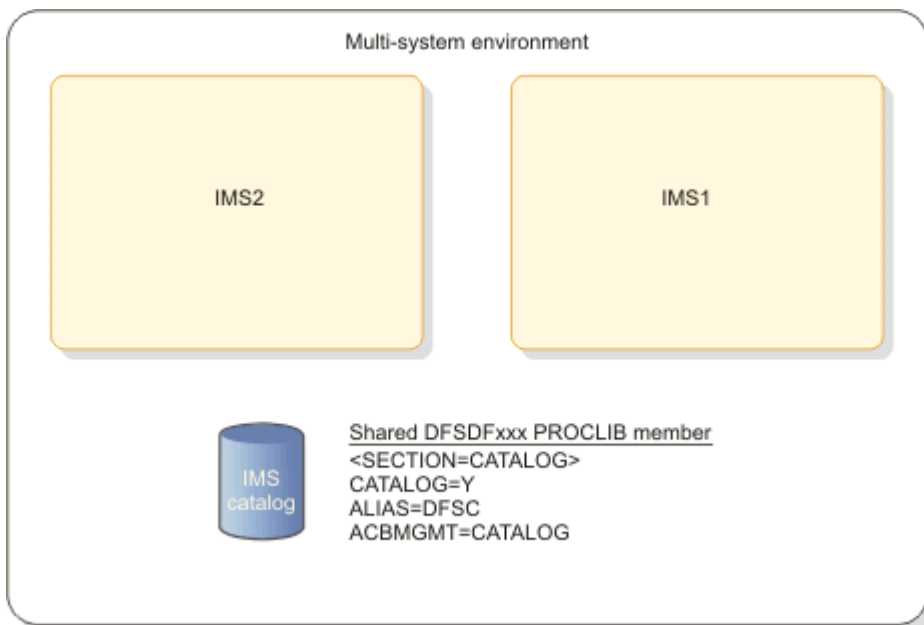

Figure 15. Two IMS systems with a shared catalog database and IMS-managed ACBs

Multiple IMS systems with independent IMS catalogs

In the following example, each IMS system in a sysplex maintains its own IMS catalog. In order to prevent name conflicts between separate catalog databases that use the same default name on multiple systems, each system has a configurable alias name in the DFSDFxxx PROCLIB member. The alias name masks the default catalog database name. The following figure shows an example of this scenario where two IMS systems in a multi-system environment maintain their own catalog databases. In this scenario, the IMS systems in the multi-system environment have independent catalogs that are specified with separate <CATALOGxxxx> sections of a shared DFSDFxxx IMS.PROCLIB member.

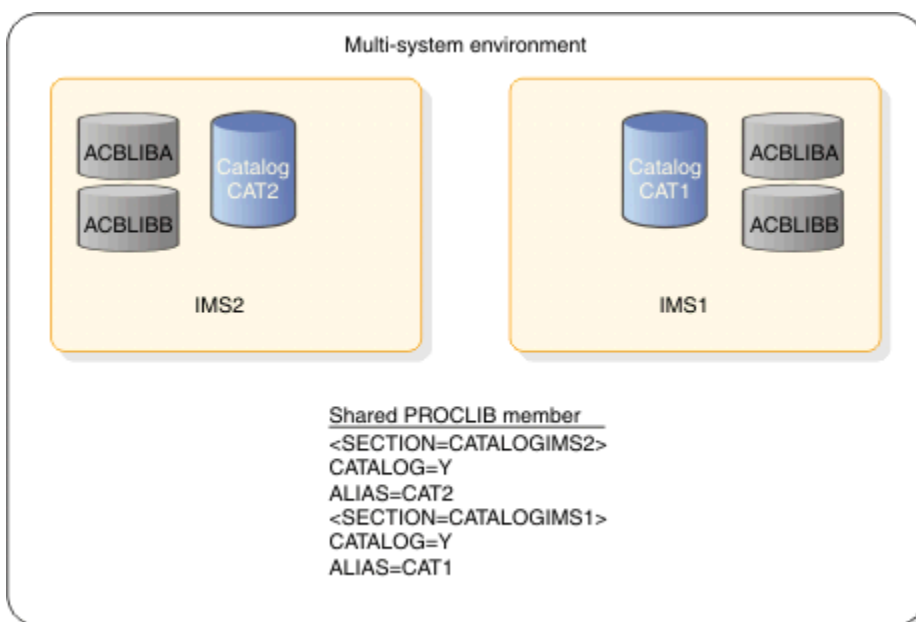

Figure 16. Two IMS systems with independent catalog databases in a multi-system environment

The following example is the same as the preceding example, except that each IMS system maintains its own DFSDFxxx PROCLIB member. As a result, each system uses the <CATALOG> section heading instead of the <CATALOGxxxx> section heading.

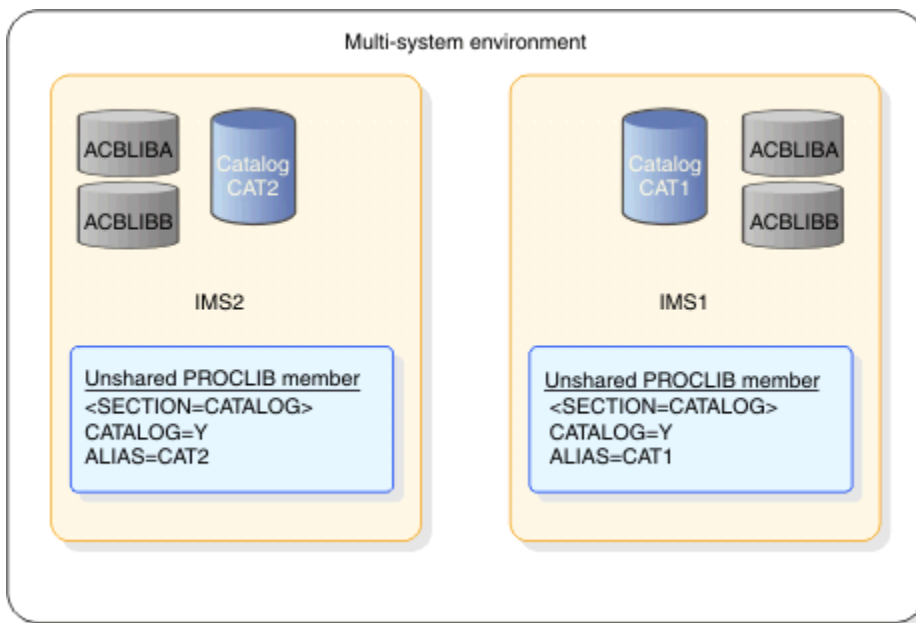

Figure 17. Two IMS systems with independent catalog databases and individual IMS.PROCLIB members in a multi-system environment

Multiple IMS systems with independent IMS catalogs and IMS-managed ACBs

In the following example, each IMS system in a sysplex maintains its own IMS catalog. The two IMS systems share a DFSDFxxx member but each uses a separate <CATALOGxxxx> section to define a different alias name for each IMS catalog. The IMS management of ACBs is enabled for each IMS system by a specification of ACBMGMT=CATALOG in each <CATALOGxxxx> section, so ACB library data sets are not used.

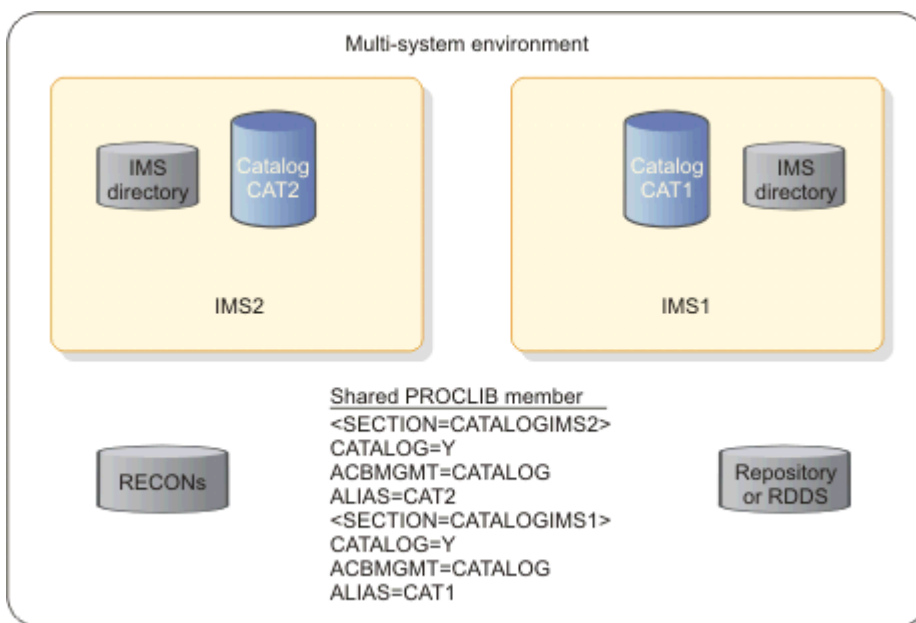

Figure 18. Two IMS systems with independent catalog databases in a multi-system environment

A mixed-case example with IMS-managed ACBs

A single multi-system environment can contain both a shared IMS catalog that is used by some IMS systems, as well as one or more independent IMS catalogs that are each used by only one IMS system.

However, any single environment can contain only one shared catalog database and each IMS system can use only one catalog database at a time.

In the following example, IMS1 and IMS2 share IMS catalog CAT1 while IMS3 has its own IMS catalog, CAT3.

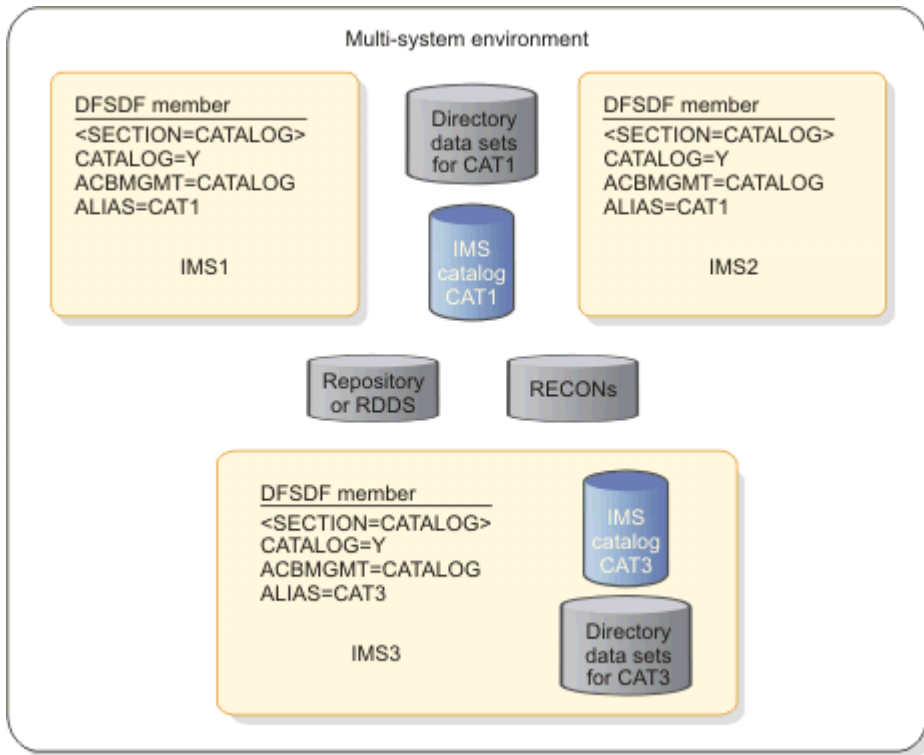

Figure 19. Two IMS systems with independent catalog databases in a multi-system environment

Related concepts

[Data sharing in IMS environments \(System Administration\)](#)

[Supporting data sharing \(System Administration\)](#)

[DBRC groups \(System Administration\)](#)

Related reference

[“CATALOG and CATALOGxxxx sections of the DFSDFxxx member” on page 756](#)

The CATALOG and CATALOGxxxx sections contain options for an IMS catalog. The section headers must be specified as `<SECTION=CATALOG>` or `<SECTION=CATALOGxxxx>`. The CATALOG and CATALOGxxxx sections are valid in DB/DC, DBCTL, DCCTL and batch environments.

Security for the IMS catalog

The IMS catalog is a system database so take every precaution to protect it from unauthorized access or corruption. If the IMS catalog is corrupted in anyway, access to all IMS databases could be affected.

Use command security to prevent unauthorized changes to the status and availability of the IMS catalog.

Protect the catalog database data sets from unauthorized access.

Only update the IMS catalog by using the appropriate IMS utilities.

Related concepts

[Database security \(Database Administration\)](#)

[Protecting databases \(System Administration\)](#)

[Protecting your resources \(System Administration\)](#)

Copying an IMS catalog

You can copy an IMS™ catalog by using the IMS Catalog Copy utilities, which consist of the IMS Catalog Export utility (DFS3CCE0) and the IMS Catalog Import utility (DFS3CCI0).

About this task

You might copy an IMS catalog for a number of reasons, such as copying an IMS catalog between test and production environments, cloning an IMS catalog across IMS systems in a multi-system environment, or copying an IMS catalog to a disaster recovery site.

If the IMS management of ACBs is enabled, you can copy the active ACBs that are managed by IMS by specifying the CCUDIREX in the JCL of the IMS Catalog Export utility (DFS3CCE0). Then, you can install the copied ACBs into the target IMS system by specifying the CCUDIRIM DD statement in the JCL of the IMS Catalog Import utility.

Related tasks

[“Defining an IMS catalog alias name” on page 285](#)

When your IMS environment includes multiple IMS catalog databases, you differentiate between the IMS catalogs by assigning unique alias names to the IMS catalogs when they are first defined.

Related reference

[“CATALOG and CATALOGxxxx sections of the DFSDFxxx member” on page 756](#)

The CATALOG and CATALOGxxxx sections contain options for an IMS catalog. The section headers must be specified as <SECTION=CATALOG> or <SECTION=CATALOGxxxx>. The CATALOG and CATALOGxxxx sections are valid in DB/DC, DBCTL, DCCTL and batch environments.

[IMS Catalog Copy utilities \(DFS3CCE0, DFS3CCI0\) \(System Utilities\)](#)

[IMS Catalog Alias Names utility \(DFS3ALIO\) \(System Utilities\)](#)

Copying an IMS catalog that does not contain IMS-managed ACBs

You can create a copy of an IMS catalog and, optionally, copies of the ACB, DBD, and PSB library data sets that were used to populate the IMS catalog by using the IMS™ Catalog Copy utility (DFS3CCE0, DFS3CCI0).

About this task

When you copy an IMS catalog, you must ensure that the copy is consistent with the ACB, DBD, and PSB libraries of the destination environment. To ensure consistency, you can use the IMS Catalog Copy utility to copy the ACB, DBD, and PSB libraries in the same job step that it copies the IMS catalog.

The IMS Catalog Export utility copies all of the DBD and PSB records in an IMS catalog. However, if an ACB library is specified on the IMSACB DD statement in the export JCL, the IMS Catalog Export utility copies only the segments in a DBD or PSB record that have a timestamp that matches the timestamp of the corresponding member in the specified ACB library. If the IMSACB DD statement is omitted, the utility copies all timestamp versions of the segments in every DBD or PSB record in the IMS catalog.

If an ACB library is specified on the IMSACB DD statement, but the ACB member for a particular DBD or PSB record in the IMS catalog is not found, the utility issues a warning message and copies all timestamp versions of the segments in the record.

If you are introducing a copy of an IMS catalog in an environment where multiple IMS catalogs are managed by DBRC in the same RECON data set, each IMS catalog must be registered in the RECON data set by using a unique alias name. If you need to define a new alias name for the copy of the IMS catalog, additional steps are required.

Procedure

To copy an IMS catalog:

1. Code the JCL statements of the DFS3CCE0 export program of the IMS Catalog Copy utility.

2. Run the IMS Catalog Copy utility in the original environment to export the IMS catalog and any optional ACB library, DBD library, and PSB library to export data sets.
3. Send the export data sets to the destination environment.
4. If you are introducing a new IMS catalog in the destination environment, in the DFSDFxxx member of the IMS.PROCLIB data set, code an entry for the IMS catalog.
If the destination environment includes multiple IMS catalogs that are managed by DBRC in a single RECON data set, specify a unique alias name on the ALIAS parameter in the DFSDFxxx entry.
5. If you specified the ALIAS parameter in a new DFSDFxxx entry, run the IMS Catalog Alias Name utility (DFS3ALIO).
6. If you are introducing a new IMS catalog in the destination environment, register the IMS catalog database and partitions in the RECON data set by using the DBRC commands **INIT.DB** and **INIT.PART**.
If you defined an alias name for the IMS catalog, specify the alias name as the DBD name on the **INIT** commands.
7. Code the JCL statements for the DFS3CCIO import program of the IMS Catalog Copy utility.
8. Run the IMS Catalog Copy utility to import the copy of the IMS catalog and any ACB library, DBD library, and PSB library into data sets in the destination environment.

Related tasks

[“Defining an IMS catalog alias name” on page 285](#)

When your IMS environment includes multiple IMS catalog databases, you differentiate between the IMS catalogs by assigning unique alias names to the IMS catalogs when they are first defined.

Related reference

[“CATALOG and CATALOGxxxx sections of the DFSDFxxx member” on page 756](#)

The CATALOG and CATALOGxxxx sections contain options for an IMS catalog. The section headers must be specified as <SECTION=CATALOG> or <SECTION=CATALOGxxxx>. The CATALOG and CATALOGxxxx sections are valid in DB/DC, DBCTL, DCCTL and batch environments.

[IMS Catalog Copy utilities \(DFS3CCE0, DFS3CCIO\) \(System Utilities\)](#)

[IMS Catalog Alias Names utility \(DFS3ALIO\) \(System Utilities\)](#)

Copying an IMS catalog that contains IMS-managed ACBs

If the IMS management of ACBs is enabled, you can copy the active ACBs that are managed by IMS by specifying the CCUDIREX in the JCL of the IMS Catalog Export utility (DFS3CCE0). Then, you can install the copied ACBs into the target IMS system by specifying the CCUDIRIM DD statement in the JCL of the IMS Catalog Import utility.

About this task

The CCUDIREX DD statement must point to the data set that will contain the information about the active ACBs that is required to populate a target IMS system with the ACBs. To install the copied ACBs into the target IMS system, specify the CCUDIRIM DD statement in the JCL of the IMS Catalog Import utility. The CCUDIRIM DD statement must point to the data set that contains the information about the active ACBs that are from the originating IMS-managed ACB environment.

If the IMS management of ACBs is enabled, use the CCUDIREX DD statement for the catalog system export data set that is required to copy the active ACBs managed by the IMS catalog. The catalog system export data set contains information about the active ACBs that are in the IMS catalog directory and the corresponding DBD and PSB records that are in the IMS catalog. If no active ACBs are found in the IMS catalog directory, the IMS catalog directory is not copied and exported.

The IMS Catalog Import utility uses the CCUDIRIM DD statement to copy only the segments that represent the active ACBs into the IMS directory at the destination environment.

If you use the CCUDIREX and CCUDIRIM DD statements to copy the active ACBs in an IMS-managed ACBs environment, the following DD statements are ignored:

- CCUACBEX and CCUACBIM
- CCUACB
- CCUDBDEX and CCUDBDIM
- CCUDBD
- CCUPSBEX and CCUPSBIM
- CCUPSB DD

Database versioning is not supported by the IMS Catalog Copy utility. If database versioning is enabled, to include the DBD and PSB records that do not have corresponding active ACBs in the copy of the IMS catalog database, you must first run the IMS Catalog Copy utility without specifying the CCUDIREX DD statement to copy all of the records in the IMS catalog. Then, to copy active ACBs, you must run the IMS Catalog Copy utility again with the CCUDIREX DD statement specified.

For more information about copying the DBD instances that do not have corresponding active ACBs, see [“Copying an IMS catalog that does not contain IMS-managed ACBs” on page 291.](#)

Procedure

To copy an IMS catalog when the IMS management of ACBs is enabled, perform the following steps:

1. Code the JCL statements of the DFS3CCE0 export program of the IMS Catalog Export utility. Specify the CCUDIREX DD statement to define the output data set for the copy of the active ACBs that are managed by IMS.
2. Run the IMS Catalog Export utility in the original environment to export the active ACBs that are managed by IMS.
3. Send the export data sets to the destination environment.
4. If you are introducing a new IMS catalog in the destination environment, in the DFSDFxxx member of the IMS.PROCLIB data set, code an entry for the IMS catalog.

If the destination environment includes multiple IMS catalogs that are managed by DBRC in a single RECON data set, specify a unique alias name on the ALIAS parameter in the DFSDFxxx entry.

5. If you specified the ALIAS parameter in a new DFSDFxxx entry, run the IMS Catalog Alias Name utility (DFS3ALIO).
6. If you are introducing a new IMS catalog in the destination environment, register the IMS catalog database and partitions in the RECON data set by using the DBRC commands **INIT.DB** and **INIT.PART**.

If you defined an alias name for the IMS catalog, specify the alias name as the DBD name on the **INIT** commands.

7. Code the JCL statements for the DFS3CCIO import program of the IMS Catalog Import utility. Include the CCUDIRIM and CCUCATIM DD statements and specify one of the following IMS catalog PSBs:
 - If an IMS catalog does not already exist at the destination environment, specify the PSB DFSCPL00.
 - If an IMS catalog already exists at the destination environment, specify the PSB DFSCP001.
8. Run the IMS Catalog Import utility to import the copy of the IMS catalog and the active ACBs that it manages in the destination environment.
 - If the target IMS environment does not already have an IMS directory data set, which is required by IMS to manage the active ACBs at the destination environment, specify the MANAGEDACBS=SETUP control statement by using the SYSINP DD statement.
 - If the IMS directory already exists at the destination environment, specify the MANAGEDACBS=STAGE or MANAGEDACBS=UPDATE control statement by using the SYSINP DD statement, or both.

Related reference

[INIT.DB command \(Commands\)](#)

[INIT.PART command \(Commands\)](#)

[CATALOG and CATALOGxxxx sections of the DFSDFxxx member \(System Definition\)](#)

Activity records for the IMS catalog

IMS can log certain types of activity that affect the IMS catalog in a type-29, subtype-3 record that is captured by z/OS System Management Facility (SMF).

IMS records the DDL statement that was issued in an SMF type-29, subtype-3 record.

System programmers and administrators can use the activity record in SMF to review IMS catalog activities.

The type-29 record is exclusive to IMS, and its subtype-3 record is exclusive to the IMS catalog activity record feature.

SMF prerequisites

To use the IMS catalog activity record, the following SMF prerequisites must be met:

- SMF must be installed in z/OS.
- SMF must be configured to accept type-29, subtype-3 records in the settings for SMF parameter SYS1.PARMLIB(SMFPRMxx) in z/OS.

IMS queries z/OS to confirm that SMF type-29, subtype-3 records are to be captured. If not, IMS does not call SMF to write the record.

Related reference

[z/OS: SMFPRMxx SMF parameters](#)

Format of IMS catalog activity records

IMS catalog activity records are stored as type-29, subtype-3 records in z/OS System Management Facility (SMF).

The BPESMF29 macro contains the DSECTS for both the SMF type 29 and the BPE headers.

SMF header

Table 42. SMF header (type 29) – BPESMF29 DSECT			
Name	Length	Type	Description
smf29len	2	binary	Record length
smf29seg	2	binary	Segment descriptor
smf29flg	1	binary	System indicator flag: <ul style="list-style-type: none"> • x'80' – Reserved • x'40' – Subtype used • x'20' – Reserved • x'10' – MVS/SP version 4 and above • x'08' – MVS/SP version 3 • x'04' – MVS/SP Version 2 • x'02' – VS2 • x'01' – Reserved
smf229rty	1	binary	Record type (29 decimal or x'1D')
smf29tme	4	binary	Time since midnight in hundredths of a second
smf29dte	4	packed	Date (packed decimal) when the record was moved into the SMF buffer

Table 42. SMF header (type 29) – BPESMF29 DSECT (continued)

Name	Length	Type	Description
smf29sid	4	EBCDIC	System identification
smf29ssi	4	EBCDIC	Subsystem identification
smf29sty	2	binary	Record subtype
smf29trn	2	binary	Number of triplets in this record
*	2		Reserved
smf29bhs	4	binary	Offset to BPE header from start of record
smf29bhl	2	binary	Length of BPE header
smf29bhn	2	binary	Number of BPE header
smf29sts	4	binary	Offset to subtype specific section from start of record
smf29stl	2	binary	Length of subtype specific section
smf29stn	2	binary	Number of subtype specific section

The smf29bhs, smf29bhl, and smf29bhn fields will be zero because the BPE headers are not written for an IMS catalog activity record.

Example subtype 3 log records

Subtype-3 records have a self-defining "triplet" section at offset SMF29STS from the start of the record. These triplets define the offsets, lengths, and number of follow-on sections in the record. For example:

Table 43. Example Self-defining triplets

Name	Length	Type	Description
SMF29STY3_N	2	binary	Number of triplets in this section
*	2	binary	Reserved
SMF29STY3_CS0	4	binary	Offset to common section
SMF29STY3_CSL	2	binary	Length of common section
SMF29STY3_CSN	2	binary	Number of common sections
SMF29STY3_TSO	4	binary	Offset to type-specific section
SMF29STY3_TSL	2	binary	Length of type-specific section
SMF29STY3_TSN	2	binary	Number of type-specific sections

Sub-type-3 records have a common section at offset SMF29STY3_CS0. This common section contains all the common elements found in all catalog activity records. For example:

Table 44. Example common section

Name	Length	Type	Description
SMF29STY3_PVER	2	binary	Version number. Indicates the iteration of the format of the SMF record layout. This value will increase by one with each subsequent change to the layout.
SMF29STY3_FUNC	2	binary	Type of activity recorded. See the DFS3SMF macro for valid values.

Table 44. Example common section (continued)

Name	Length	Type	Description
SMF29STY3_RECNUM	2	binary	Remaining continuation records for partial records. If the type-specific portion length exceeds the amount of space in a single SMF record, then multiple SMF records will be written, each with a portion of the total type-specific data. SMF29STY3_RECNUM will be non-zero (and decreasing) until the last record, which will be zero.
SMF29STY3_FLAGS	2	binary	Field flag bytes (not currently used).
SMF29STY3_JOBNAME	8	EBCDIC	Job name of the process that is initiating the record.
SMF29STY3_USERID	8	EBCDIC	ID of the process that is initiating the record.
SMF29STY3_IDLEN	2	binary	Length of the process identifier.
SMF29STY3_ID	64	EBCDIC	Process identifier. If present, provides more identifying information for the process that is initiating the record.
SMF29STY3_STCKE	16	binary	Store clock (STCKE).
SMF29STY3_IMSID	4	EBCDIC	IMS id

Subtype-3 records have a component- or type-specific section at offset SMF29STY3_TS0 from the beginning of the record. Each provider of subtype-3 records determines the contents and layout of the type-specific section. See the DFS3SMF macro for the layout.

Chapter 11. IMS Connect definition and tailoring

This topic describes the tasks of defining and tailoring IMS Connect. It provides detailed information about configuring and customizing the IMS Connect environment, as well as guidelines and procedures for using and invoking IMS Connect.

IMS Connect provides the following services:

- TCP/IP gateway to IMS, including support for:
 - ISC parallel sessions on ISC links with IBM CICS Transaction Server for z/OS.
 - IMS to IMS TCP/IP communications support for:
 - IMS Multiple Systems Coupling (MSC) networks
 - OTMA transaction messages
 - TCP/IP access to IMS DB using Structured Call Interface (SCI) connections to Open Database Manager
 - TCP/IP access to IMS TM using z/OS cross-system coupling facility connections to Open Transaction Manager Access (OTMA)
- TCP/IP access to IMS type-2 commands through SCI and the IMS Operations Manager OM interface

Related concepts

[Overview of IMS Connect \(Communications and Connections\)](#)

Sample JCL to start IMS Connect

You can use this sample JCL to start IMS Connect as a z/OS procedure or job.

You invoke IMS Connect by using either a z/OS procedure or a z/OS job. If you start multiple instances of IMS Connect with the same configuration, a connection outage can occur.

To avoid starting the same IMS Connect address space more than once, start IMS Connect by running a z/OS job with a unique z/OS initiator class assigned to it, rather than starting the connection as a procedure. The following sample starts IMS Connect as a z/OS job:

```
//HWS01 JOB MSGLEVEL=1,TIME=1440,CLASS=Y,USERID=&USERID
//*****
//* BRING UP IMS CONNECT USING A JOB *
//*****
//HWS01 EXEC HWS,SOUT=A
```

Two examples of starting IMS Connect as a z/OS procedure are shown below. In the first example, the JCL statements illustrate that both IMS Connect and BPE have configuration members (HWSCFG00 and BPECFGHT). In addition, PGM=HWSHWS00 is required to run IMS Connect in authorized supervisor state and key 7.

```
//HWS PROC RGN=0M,SOUT=A,
// BPECFG=BPECFGHT,
// HWSCFG=HWSCFG00
//*
//*****
//* BRING UP AN IMS CONNECT USING HWSHWS00 *
//*****
//STEP1 EXEC PGM=HWSHWS00,REGION=&RGN,TIME=1440,
// PARM='BPECFG=&BPECFG,HWSCFG=&HWSCFG'
//STEPLIB DD DSN=SDFSRESL,DISP=SHR
// DD DSN=CEE.SCEERUN,UNIT=SYSDA,DISP=SHR
// DD DSN=SYS1.CSSLIB,UNIT=SYSDA,DISP=SHR
// DD DSN=GSK.SGSKLOAD,UNIT=SYSDA,DISP=SHR
//PROCLIB DD DSN=USER.PROCLIB,DISP=SHR
//SYSPRINT DD SYSOUT=&SOUT
//SYSUDUMP DD SYSOUT=&SOUT
//HWSRCORD DD DSN=HWSRCRD,DISP=SHR
```

In the second example, the BPE program properties table entry, BPEINI00 is used instead of HWSHWS00. When you use BPEINI00, the address space runs in authorized supervisor state and key 7. IMS Connect uses BPEINI00 unless you explicitly identify PGM=HWSHWS00, as in the example above. If you use BPEINI00, you must also add the BPEINIT=HWSINI00 parameter, which identifies the HWS BPE initialization parameters module. A sample startup procedure using BPEINI00 is shown below.

```
//HWS      PROC  RGN=0M,SOUT=A,
//          BPECFG=BPECFGHT,
//          HWSCFG=HWSCFG00
// *
// *****
// * BRING UP AN IMS CONNECT USING BPEINI00
// *****
//STEP1    EXEC  PGM=BPEINI00,REGION=0M,TIME=1440,
//            PARM='BPECFG=&BPECFG,BPEINIT=HWSINI00,
//            HWSCFG=&HWSCFG'
//STEPLIB  DD   DSN=SDFSRESL,DISP=SHR
//          DD   DSN=CEE.SCEERUN,UNIT=SYSDA,DISP=SHR
//          DD   DSN=SYS1.CSSLIB,UNIT=SYSDA,DISP=SHR
//          DD   DSN=GSK.SGSKLOAD,UNIT=SYSDA,DISP=SHR
//PROCLIB  DD   DSN=USER.PROCLIB,DISP=SHR
//SYSPRINT DD   SYSOUT=&SOUT
//SYSUDUMP DD   SYSOUT=&SOUT
//HWSRCORD DD   DSN=HWSRCRD,DISP=SHR
```

Note: The IMS.SDFSRESL library is required in the STEPLIB, because all IMS Connect modules reside in the IMS.SDFSRESL library. IMS Connect requires the CEE.SCEERUN, SYS1.CSSLIB, and GSK.SGSKLOAD libraries (which are the C execution and z/OS system SSL libraries) only when SSL support is used.

IMS Connect requires a minimum region specification of 250M. To ensure that IMS Connect can acquire adequate space above the line, specify REGION=0M.

Configuring IMS Connect

IMS Connect supports communication between one or more TCP/IP clients and IMS systems. You can configure multiple IMS systems on multiple z/OS images within a single sysplex and distribute the client request to the IMS systems (data stores).

Procedure

1. Authorize the Authorized Program Facility (APF).
 - a) Create and run a JCL job that authorizes IMS.SDFSRESL library to the APF.
 - b) Issue the z/OS command SETPROG APF ,ADD ,DSNAME=IMS .SDFSRESL ,VOLUME=IMS001.
2. Update the z/OS Program Properties Table (PPT). Updating the PPT allows IMS Connect to run in authorized supervisor state and in key 7.
 - a) Edit the SCHEDxx member of the SYS1.PARMLIB data set.
 - b) Add the required entries to the z/OS PPT.

For TCP/IP communications only, add the following entry in the z/OS PPT:

```
PPT PGMNAME(HWSHWS00) /* PROGRAM NAME = HWSHWS00 */
      CANCEL          /* PROGRAM CAN BE CANCELED */
      KEY(7)          /* PROTECT KEY ASSIGNED IS 7 */
      SWAP            /* PROGRAM IS SWAPPABLE */
      NOPRIV          /* PROGRAM IS NOT PRIVILEGED */
      DSI             /* REQUIRES DATA SET INTEGRITY */
      PASS            /* CANNOT BYPASS PASSWORD PROTECTION */
      SYST            /* PROGRAM IS A SYSTEM TASK */
      AFF(NONE)       /* NO CPU AFFINITY */
```

- c) IPL the z/OS system again or issue the z/OS SET SCH= command to make the changes effective.
3. Enable Internet Protocol Version 6 (IPV6) for IMS Connect.
 - a) Ensure that IMS Connect is running.
 - b) Customize the BPXPRMxx member, as follows:

```

FILESYSTYPE Type(INET) Entrypoint(EZBPFINI)
NETWORK DOMAINNAME(AF_INET)
DOMAINNUMBER(2)
MAXSOCKETS(2000)
TYPE(INET)

NETWORK DOMAINNAME(AF_INET6)
DOMAINNUMBER(19)
MAXSOCKETS(3000)
TYPE(INET)

```

- c) Recycle the TCP/IP stack. For more information about customizing this member, see *z/OS UNIX System Services Planning*.
- d) Customize the IMS Connect configuration member using the IPV6 parameter.
- e) For each of the READ subroutines shown below that you use, determine whether the EXPREA_IPV6 bit is turned on in the EXPREA_FLAG2 field of the READ subroutine. If it is turned on, IPV6 is enabled.
 - HWSJAVA0
 - HWSSMPL0
 - HWSSMPL1
- f) Map EXPREA_SOCKET6 to the AF_INET6 socket address structure. See "READ subroutine" in *IMS Version 15.4 Exit Routines* for more information.

The IP address format when IPV6 is enabled is described in "VIEWHWS command" in *IMS Version 15.4 Commands, Volume 3: IMS Component and z/OS Commands*.

4. Create an IMS Connect configuration member in IMS.PROCLIB data set to hold the configuration statements that IMS Connect uses during initialization.

You can specify the following configuration statements for IMS Connect to use:

- ADAPTER
- DATASTORE
- HWS
- IMSPLEX
- ISC
- MSC
- ODACCESS
- RMTICICS
- RMTIMSCON
- TCPIP

In addition, you can dynamically create, update, and delete certain IMS Connect resources by using IMS type-2 commands.

What to do next

After completing these steps, you can define IMS security and optionally enable the IMS Connect XML Message Conversion support.

Related reference

[“HWSCFGxx member of the IMS PROCLIB data set” on page 917](#)

Use the IMS Connect configuration member of the IMS PROCLIB data set, HWSCFGxx, to specify environmental settings for IMS Connect.

Defining IMS Connect security

Properly defining security for IMS Connect using RACF, and assigning IMS Connect z/OS UNIX System Services superuser privileges ensures that IMS Connect can open ports.

You can start IMS Connect as a job or as a procedure. If the data store (which is IMS) is RACF-protected, you have to start IMS Connect as a job with the JOB statement specifying a valid *USERID* to make the connection from IMS Connect to IMS, or you can use the RACF-started procedure table. The *USERID=&userid* parameter specified in the JOB card of the IMS Connect job JCL is used as the security vehicle to ensure IMS Connect access to IMS. *&USERID* must have READ access to *IMSXCF.group.member*. IMS OTMA provides security for the IMS z/OS cross-system coupling facility connection by defining and permitting *IMSXCF.group.member* in the RACF *FACILITY* class.

The IMS Connect **MAXSOC** parameter is related to the **MAXFILEPROC** parameter of UNIX System Services, which can be overridden by the **FILEPROCMAX** field of the OMVS segment of a user's profile. The values of **MAXSOC** and **MAXFILEPROC** must be compatible. If the values of each parameter are not compatible, IMS Connect cannot open any ports.

You can ensure the compatibility between **MAXSOC** and **MAXFILEPROC** by using one of the following methods:

1. The recommended method is to use the **ALTUSER** command to assign the desired value to the **FILEPROCMAX** field of the OMVS segment of the user ID that is used to start IMS Connect.

For example, the user ID *USRID01* (not a super user) is used to start IMS Connect with **MAXSOC=20000**. **MAXFILEPROC=999** is set in the BPXPRMxx member of the z/OS SYS1.PARMLIB data set. Since **MAXSOC** is greater than **MAXFILEPROC**, IMS Connect would fail to open any of its ports. To avoid this failure, specify **FILEPROCMAX** with a value at least equal to **MAXSOC** by using the following command:

```
ALTUSER USRID01 OMVS(FILEPROCMAX(20000))
```

The new **FILEPROCMAX=20000** specification overrides the **MAXFILEPROC=999** for user ID *USRID01*.

For more information about the ALTUSER (Alter user profile) command, see [ALTUSER \(Alter user profile\)](#).

2. Before you start IMS Connect, make sure the value that is specified for **MAXSOC** is less than or equal to the value of **MAXFILEPROC**. Alternatively, your UNIX System Services administrator can directly adjust the value of **MAXFILEPROC** in the BPXPRMxx member of the z/OS SYS1.PARMLIB data set.
3. This option is no longer recommended but is retained for historical purposes. You could grant UNIX System Services superuser privileges to IMS Connect by using the RACF command **ALTERUSER** to assign an OMVS segment with a UID of 0 to the user ID of the IMS Connect started task.

Related reading: For more details about OTMA and IMS Connect security, see *IMS Version 15.4 Communications and Connections*.

Related reference

[ALTUSER \(Alter user profile\)](#)

Setting up AT-TLS SSL for IMS Connect

You can set up IBM z/OS Communications Server Application Transparent Transport Layer Security (AT-TLS) to set up Secure Socket Layer (SSL) on TCP/IP connections to IMS Connect. Setting up AT-TLS is the recommended method for enabling SSL for IMS Connect.

About this task

Perform the following procedure to set up SSL for IMS Connect by setting up AT-TLS:

Procedure

1. On each z/OS system where you run IMS Connect, create a server key ring with a server certificate and the necessary certificate authority certificates.
2. Create Policy Agent files:
 - a) Create a Policy Agent main configuration file containing a `TcpImage` statement for the server stack.
Set the `TcpImage` statement to point to the image configuration file.
 - b) Create a Policy Agent image configuration file containing a `TTLSSConfig` statement for the server stack.
Set the `TTLSSConfig` statement to point to the `TTLSSConfig` policy file.
 - c) Create and configure a Policy Agent `TTLSSConfig` policy file, and add the AT-TLS policy statements to this file.
Most of the SSL settings are in this file. Set the security suite you want to support, and specify which ports to use SSL.
 - d) Store all the configuration files in a z/OS UNIX System Services file system directory that can be accessed when you start the Policy Agent.

3. Activate the RACF SERVAUTH class.

Issue the following command from TSO:

```
SETROPTS CLASSACT(SERVAUTH)
```

4. Set up `InitStack` access control:

- a) Define the `EZB.INITSTACK.SYSNAME.TCPNAME` profile for each AT-TLS stack.
- b) Permit administrative applications to use the stack before AT-TLS is initialized.

The following is sample JCL to set up `InitStack` access control (based on the member `EZARACF` in sample data set `SEZAINST`):

```
//TLSRACF JOB MSGLEVEL=(1,1),USER=USERNAME,PASSWORD=PASSWORD,
//          CLASS=A,MSGCLASS=A
//*
/*ROUTE PRINT THISCPU/IMSNAME
// EXEC PGM=IKJEFT01
//SYSTSPRT DD SYSOUT=*
//SYSABEND DD SYSOUT=*
//SYSTSIN DD *
SETROPTS RACLIST (SERVAUTH)
SETROPTS CLASSACT(SERVAUTH)
SETROPTS GENERIC (SERVAUTH)
RDEFINE SERVAUTH EZB.INITSTACK.SYSNAME.TCPNAME UACC(NONE)
PERMIT EZB.INITSTACK.SYSNAME.TCPIP CLASS(SERVAUTH) ID(*) ACCESS(READ) -
      WHEN(PROGRAM(PAGENT,EZAPAGEN))
SETROPTS GENERIC(SERVAUTH) REFRESH
SETROPTS RACLIST(SERVAUTH) REFRESH
SETROPTS WHEN(PROGRAM) REFRESH
//
```

From the z/OS console, you can find the `SYSNAME` in the `SYS=` field. To find the `TCPNAME`, issue the `D A,L` command.

5. Enable AT-TLS. Perform one of the following steps:

- Add the following lines to the `SYS1.TCPPARMS(PROFILE)` member:

```
;Enable AT-TLS support
TCPCONFIG TTLS
```

- Put the following lines in a separate file and run the `V TCPIP,,0,SYS1.TCPPARMS(filename)` (`VARY`) command:

```
;Enable AT-TLS support
TCPCONFIG TTLS
```

Note: If you perform this step, skip steps “6” on page 302 and “8” on page 302.

6. If TCP/IP and IMS Connect are running, stop TCP/IP and IMS Connect.

To stop IMS Connect, issue the IMS Connect WTOR command CLOSEHWS.

7. Configure and start the syslog daemon (syslogd):

- a) Review your syslogd configuration (/etc/syslog.conf) to verify that messages written by the Policy Agent and TCP/IP stacks are saved in the intended files.

AT-TLS syslogd messages are written to the daemon facility by default. A sample configuration file is provided by z/OS in /usr/lpp/tcpip/samples/syslog.conf.

- b) Start syslogd with the following command:

```
/usr/sbin/syslogd -f /etc/syslog.conf &
```

Note: To stop this job, run the following command: `kill process_ID`. To find the *process_ID*, run the following command: `ps -A`.

8. Start the TCP/IP stack.

Run the following command from the z/OS console:

```
S TCPIP
```

9. Start the Policy Agent and verify that there were no policy errors in processing the policy files:

- a) Run the following command:

```
/usr/sbin/pagent -c /etc/sysname_pagent.conf -l SYSLOGD &
```

The pagent executable is in /usr/sbin.

- b) Verify that the TCP/IP stack has received the AT-TLS policy and has released console message EZZ4248E.

Note: To stop this job, run the following command: `kill process_ID`. To find the *process_ID*, run the following command: `ps -A`.

10. Update the IMS Connect configuration member (HWSCFGxx) and start IMS Connect:

- a) In HWSCFGxx, specify the ports that you want to use for SSL as regular non-SSL ports.

Perform one or both of the following steps:

- If you are connecting to IMS TM, specify the ports in the PORT and PORTID parameters on the TCPIP statement.
- If you are connecting to IMS DB, specify the ports in the DRDAPORT parameter on the ODACCESS statement.

If a specified port matches one of the SSL ports from the *sysname_pagent_TTLS.conf* file, an SSL client can connect to that port. If no specified ports match an SSL port from the *sysname_pagent_TTLS.conf* file, only non-SSL clients can connect to it.

- b) If you are migrating from using IMS Connect's SSL function to using AT-TLS, then complete the following steps:

- Remove the SSLENVAR parameter. The member that is defined in this parameter is no longer required. This is because the SSL ciphers and protocols that were defined in the parameter's member are now defined in the Policy Agent TTLSConfig policy file, which you created earlier in this procedure.
- Remove the SSLPORT parameter and specify the port number in the PORT or PORTID parameter.

Here is an example that specifies port 8888 to use IMS Connect's SSL function:

```
TCPIP=(HOSTNAME=TCPIP,PORTID=(9999,9998,LOCAL),
```

To change port 8888 to use AT-TLS, remove SSLPORT and specify port 8888 in the PORTID parameter:

```
TCPIP=(HOSTNAME=TCPIP,PORTID=(9999,9998,8888,LOCAL),
```

IMS Connect treats port 8888 as a normal port. Traffic coming through this port does not go through IMS Connect's SSL function. All the SSL processing would be done by the z/OS AT-TLS stack instead.

Note: AT-TLS is the recommended method to enable SSL for IMS Connect.

c) Start IMS Connect by running JCL.

What to do next

- Configure the IMS Universal database resource adapter for SSL support in a container-managed environment.
- Configure IMS Universal drivers for SSL support in a stand-alone environment.

Related concepts

[z/OS: TLS/SSL security](#)

[z/OS: AT-TLS policy configuration](#)

Related tasks

[Configuring the IMS Universal Database resource adapter for SSL support in a container-managed environment \(Application Programming\)](#)

[Configuring IMS Universal drivers for SSL support in a stand-alone environment \(Application Programming\)](#)

Related reference

[“HWSCFGxx member of the IMS PROCLIB data set” on page 917](#)

Use the IMS Connect configuration member of the IMS PROCLIB data set, HWSCFGxx, to specify environmental settings for IMS Connect.

[z/OS: TcpImage and PEPInstance](#)

[IBM Redbooks: Defining the TcpImage statements](#)

[z/OS: TTLSConfig statement](#)

[z/OS: TCP/IP stack initialization access control](#)

[z/OS: VARY TCPIP,,START or VARY TCPIP,,STOP](#)

[z/OS: Configuring the syslog daemon](#)

[z/OS: Starting and stopping the Policy Agent](#)

Configuring XML conversion support for IMS Connect clients

You must configure IMS Connect to convert the input and output messages between an IMS Connect client and an IMS application from XML to a language-specific structure, when the IMS Connect client is IMS Enterprise Suite SOAP Gateway.

Before you begin

The following information does not apply to IMS Connect clients that are IMS Universal drivers or custom-built applications that use the Distributed Relational Database Architecture™ (DRDA) protocol.

Prerequisites:

- You must have the COBOL copybook or the PL/I source files for the IMS application program that processes the input messages or issues a callout request.
- You must increase the IMS Connect region size to accommodate the storage used by the XML converters.
- You must have IMS Enterprise Suite SOAP Gateway.

About this task

IMS Connect can convert the XML data contained in the message from an IMS Connect client into the COBOL or PL/I data used by an IMS application program. The COBOL or PL/I data in the corresponding output message is also converted back to the XML data that the IMS Connect client expects. This XML conversion support enables IMS to accept IMS Connect client messages in an XML format without modifying IMS application programs to support XML natively.

The XML conversion function supports conversion of single-segment and multi-segment messages. See the SOAP Gateway and IBM Developer for System z documentation for the restrictions that apply to multi-segment message support.

Using control data in synchronous callout messages to override the XML converter name: In outbound synchronous callout requests that are sent via SOAP Gateway, you can override the XML converter name that is used by IMS Connect. You can do so by having the IMS application program specify a different converter name in the control data area of the DL/I ICAL call when the application program issues the callout request. When the converter name is specified in the control data area, the name must be specified in uppercase EBCDIC characters and enclosed in the <DFSCVTNR> and </DFSCNVTR> tags.

Restrictions:

- IMS Enterprise Suite SOAP Gateway is the only supported client.
- Inbound and outbound messages must be encoded in UTF-8 because IMS Enterprise Suite SOAP Gateway supports only UTF-8. This encoding must match the encoding of the XML Converter that is being requested.
- IMS Connect provides XML conversion support for commit mode 1 and sync level 0 messages.

The XML conversion function supports conversion of single-segment and multi-segment messages. See the SOAP Gateway and IBM Developer for System z documentation for the restrictions that apply to multi-segment message support.

To configure IMS Connect to convert XML data from the client into COBOL or PL/I IMS application program data, you must perform the following basic steps:

Procedure

1. Include the ADAPTER configuration statement, ADAPTER=(XML=Y), in the IMS Connect configuration member HWSCFGxx.

Tip: You can increase the maximum number of XML converters that IMS Connect can load simultaneously with the MAXCVTR parameter of the ADAPTER statement. When your applications exceed the maximum number of allowable XML converters that are specified in MAXCVTR, IMS Connect unloads the least recently used XML converters first.

2. Specify the HWSSOAP1 user message exit in the EXIT= parameter of the TCPIP configuration statement.
3. Define the XML adapter as a BPE exit routine for IMS Connect by coding a BPE exit list IMS PROCLIB data set member and specifying it in the BPE configuration parameter IMS PROCLIB data set member:
 - a) Create a BPE exit list IMS PROCLIB data set member with any name, for example HWSEXIT0.

In the BPE exit list IMS PROCLIB data set member, define the XML Adapter (HWSXMLA0) as an exit by setting the following EXITDEF statement:

```
EXITDEF (TYPE=XMLADAP , EXITS=(HWSXMLA0) , ABLIM=8 , COMP=HWS)
```

All parameters must be coded as shown except for ABLIM, which sets the number of times the XML adapter can abend before it is disabled.

- b) Set the BPE exit list IMS PROCLIB data set member in the BPE configuration parameter IMS PROCLIB data set member by adding an EXITMBR statement.

For example, if the BPE exit list IMS PROCLIB data set member is HWSEXIT0, then add the following statement to the BPE configuration member:

```
EXITMBR=(HWSEXIT0,HWS)
```

4. Configure the z/OS Unicode Conversion Services to support character conversions from UTF-8 to EBCDIC and from EBCDIC to UTF-8.

Most likely, your z/OS system administrator performs this task. For more information about z/OS Unicode support, see *z/OS Unicode Services User's Guide and Reference*.

5. Generate the XML converter to convert the XML data to the COBOL or PL/I data that the IMS application expects.

XML converters are COBOL or PL/I application programs that are based on the COBOL copybook or PL/I source code of the IMS application program that processes the transactions between the IMS Connect client and the IMS application.

The recommended method is by using the separately licensed tool IBM Developer for System z to generate the converters. Each IMS application requires a unique XML converter. For IMS Enterprise Suite SOAP Gateway, you can find an example of an XML converter in the IMS Enterprise Suite SOAP Gateway Phone Book Sample. You can download the sample from the IMS Enterprise Suite SOAP Gateway home page.

6. Compile and link the XML converter into an APF-authorized data set that is concatenated to the STEPLIB in the IMS Connect startup JCL.

When linking the XML converter, specify an additional program entry name for an internal service as an ALIAS in the link job. The additional program entry name has the same name as the converter, except that the last character is an X. For example, if the converter name is CNVNAMED, the additional program entry name is CNVNAMEX.

7. If you are updating an existing converter, refresh it by issuing one of the following commands:

- The z/OS Modify command **UPDATE CONVERTER**
- The WTOR command **REFRESH CONVERTER**
- The type-2 command **UPDATE IMSCON TYPE(CONVERTER)**

8. Configure your IMS Enterprise Suite SOAP Gateway and provide the generated XML converter.

For detailed configuration instructions for IMS Enterprise Suite SOAP Gateway, see the [XML-formatted IMS messages](#) documentation.

Example

Example IMS Connect configuration statements:

The following example shows the IMS Connect configuration statement specifications required to enable the XML conversion function of IMS Connect:

```
*****
* HWS EXAMPLE OF INCLUDING XML ADAPTER SUPPORT
*****
HWS=(ID=HWS8,RACF=Y,XIBAREA=20)
TCP/IP=(HOSTNAME=MVSTCPIP,RACFID=RACFID,
PORTID=(9999,LOCAL),MAXSOC=2000,TIMEOUT=8800,
EXIT=(HWSSMPL1,HWSSOAP1))
ADAPTER=(XML=Y)
*****
```

Example JCL to compile and link a COBOL program:

The following example JCL compiles and links an XML converter (for COBOL):

```
//COBLNK JOB (PLS,81038),'user',CLASS=A,REGION=4096K,
// MSGLEVEL=(1,1),MSGCLASS=A,NOTIFY=user
//*****
//* JOB TO COMPILE AND LINK A COBOL PROGRAM
//*****
//COMP EXEC PGM=IGYCRCTL
//STEPLIB DD DSN=COBOL.V3R4.X,DISP=SHR
```

```

//SYSIN DD DSN=COBOL.SOURCE(NNNNNND),DISP=SHR
//SYSLIN DD DSN=&OBJ,SPACE=(3040,(40,40),,,ROUND),UNIT=VIO,
// DISP=(MOD,PASS),
// DCB=(BLKSIZE=3040,LRECL=80,RECFM=FBS,BUFNO=1)
//SYSUT1 DD UNIT=VIO,SPACE=(1024,(120,120),,,ROUND)
//SYSUT2 DD UNIT=VIO,SPACE=(1024,(120,120),,,ROUND)
//SYSUT3 DD UNIT=VIO,SPACE=(1024,(120,120),,,ROUND)
//SYSUT4 DD UNIT=VIO,SPACE=(1024,(120,120),,,ROUND)
//SYSUT5 DD UNIT=VIO,SPACE=(1024,(120,120),,,ROUND)
//SYSUT6 DD UNIT=VIO,SPACE=(1024,(120,120),,,ROUND)
//SYSUT7 DD UNIT=VIO,SPACE=(1024,(120,120),,,ROUND)
//SYSPRINT DD SYSOUT=*
//SYSUDUMP DD SYSOUT=*
/*
//*****
//LKED EXEC PGM=IEWL,COND=(4,LT,COMP),
// PARM='LIST,LET,XREF,MAP'
//SYSLIB DD DSN=CEE.SCEELKED,DISP=SHR
// DD DSN=CEE.SCEEBIND,DISP=SHR
// DD DSN=CEE.SCEEBND2,DISP=SHR
//SYSLIN DD DSN=&OBJ,DISP=(OLD,DELETE)
// DD DDNAME=SYSIN
//SYSLMOD DD DSN=IMSCONN.AUTHLIB,DISP=SHR
//SYSUT1 DD UNIT=VIO,SPACE=(1024,(120,120),,,ROUND)
//SYSPRINT DD SYSOUT=*
//LKED.SYSIN DD *
ENTRY NNNNNND
ALIAS NNNNNNX
NAME NNNNNND(R)
/*

```

What to do next

For information about the XML, COBOL, and PL/I data structures of converted input and output messages, see *IMS Version 15.4 Application Programming*.

Related concepts

[IMS Connect XML message conversion \(Communications and Connections\)](#)

[Callout request approaches \(Application Programming\)](#)

Related reference

[REFRESH CONVERTER command \(Commands\)](#)

[IMS Connect UPDATE CONVERTER command \(Commands\)](#)

[“HWSCFGxx member of the IMS PROCLIB data set” on page 917](#)

Use the IMS Connect configuration member of the IMS PROCLIB data set, HWSCFGxx, to specify environmental settings for IMS Connect.

Configuring the IMS Base Primitive Environment for IMS Connect

The IMS Connect address space is built on top of the Base Primitive Environment (BPE).

Changing the BPE configuration parameter member of the IMS PROCLIB data set

The BPE configuration parameter member of the IMS PROCLIB data set defines BPE execution environment settings for the IMS Connect address space. You specify the IMS PROCLIB data set member name by coding `BPECFG=member_name` on the EXEC PARM= statement in the IMS Connect address space startup JCL, as shown in the following example:

```
EXEC HWSHWS00,PARM='BPECFG=BPECFGHW'
```

You can use the BPE configuration parameter member of the IMS PROCLIB data set to specify the following items:

- The language used for BPE and IMS Connect messages
- The trace level settings for BPE and IMS Connect internal trace tables

The keywords that are available for the BPE configuration parameter member of the IMS PROCLIB data set are LANG= and TRCLEV=.

Avoid coding statements in the BPE configuration member that specify definitions for the same resources more than one time. For example, do not specify multiple TRCLEV statements for the same trace table type, or multiple EXITMBR statements for the same IMS Connect. BPE uses the last statement it encounters in the member. Any values that are specified on earlier duplicate statements are ignored. A message BPE0017I is issued for each duplicate found.

The IMS Connect Recorder trace table, RCTR, requires explicit commands, and therefore, is not processed if a default TRCLEV statement, TRCLEV=(*,HWS), is defined for IMS Connect. Recorder trace table configuration must be explicitly specified with a separate, additional TRCLEV statement. For example: TRCLEV=(RCTR,MEDIUM,HWS).

Recommendation: Enable the RCTR trace by issuing the BPE **UPDATE TRACETABLE** command. Use the BPE configuration member only if you must capture the trace before the BPE **UPDATE TRACETABLE** command can be issued.

Formatting incore trace tables

IMS Connect trace tables are *incore* tables, which can be formatted from a dump of an IMS Connect address space using the IMS Connect dump formatter. The traces are formatted by the standard BPE formatting services.

Example of a configuration file for BPE

A sample BPE configuration data set is shown in the following figure.

```
*****
* CONFIGURATION FILE FOR BPE                               *
*****

LANG=ENU                                /* LANGUAGE FOR MESSAGES */
                                        /* (ENU = U.S. ENGLISH)  */

#
# DEFINITIONS FOR BPE SYSTEM TRACES
#

TRCLEV=(*,LOW,BPE)                       /* DEFAULT TRACES TO LOW */
TRCLEV=(AWE,HIGH,BPE)                   /* AWE SERVER TRACE ON HIGH */
TRCLEV=(CBS,MEDIUM,BPE)                 /* CTRL BLK SRVCS TRC ON MED */
TRCLEV=(DISP,HIGH,BPE,PAGES=12)        /* DISPATCHER TRACE ON HIGH */
                                        /* WITH 12 PAGES (48K BYTES) */

#
# DEFINITIONS FOR IMS CONNECT TRACES
#

TRCLEV=(*,HIGH,HWS)                     /* DEFAULT ALL IMS CONNECT TRACES TO HIGH */
TRCLEV=(HWSI,MEDIUM,HWS)                /* BUT RUN IMS CONNECT TO IMS OTMA TRACE... */
TRCLEV=(HWSW,MEDIUM,HWS)                /* AND SERVER TO IMS CONNECT TRACE AT MEDIUM */
TRCLEV=(RCTR,MEDIUM,HWS)                 /* AND SET RECORDER TRACE TO MEDIUM BECAUSE */
                                        /* IT IS NOT PROCESSED WITH THE ALL DEFAULT */
```

Related reference

[BPE UPDATE TRACETABLE command \(Commands\)](#)

Allocating IMS Connect log record data sets

IMS Connect writes log records to the HWSRCRDR data set.

Recommendation: Instead of setting up IMS Connect to write log records to the HWSRCRDR data set, use the Base Primitive Environment (BPE) to manage the output of the IMS Connect Recorder Trace facility. Configure BPE for an external trace of IMS Connect.

To allocate the HWSRCRDR data set from TSO, use the following settings:

```

                                Data Set Information
Command ===>
Data Set Name . . . .: HWSRCDR

General Data                    Current Allocation
Volume serial. . . .: USER01    Allocated cylinders: 1
Device type . . . .: 3390        Allocated extents. : 1
Organization . . . .: PS
Record format. . . .: FB
Record length. . . .: 1440
Block size . . . .: 14400        Current Utilization
1st extent cylinders: 1          Used cylinders . . : 1
Secondary cylinders : 5          Used extents . . . : 1

Creation date . . . .: 2011/10/01
Expiration date . . .: ***None***

```

Refer to the *Program Directory for Information Management System Transaction and Database Servers* for the recommended allocations for the required IMS Connect libraries.

Related tasks

[Configuring BPE for an external trace of IMS Connect \(Diagnosis\)](#)

JCL to print IMS Connect RECORDER output

IMS Connect provides a line trace function to capture data that is received from and sent to a client.

The line trace contains a copy of the first 670 bytes of the data as it is passed to the user message exit and upon return from the user message exit. Line traces are intended for use in problem resolution.

Use the RECORDER command to activate and terminate the line trace function.

The following sample JCL illustrates how to print the line trace data set:

```

//IDCAMS JOB JOB 1, IDCAMS, MSGLEVEL=1, CLASS=K, TIME=1440
//SELECT EXEC PGM=IDCAMS
//DD1 DD DSN=HWSRCDR, DISP=SHR
//SYSPRINT DD SYSOUT=*
//SYSIN DD *
PRINT INFILE(DD1)

```

For information about the IMS Connect Event Recorder exit routine (HWSTECL0), see *IMS Version 15.4 Exit Routines*.

Chapter 12. Enabling open access to IMS data

To enable open access to IMS data, you need to set up IMS support for the IMS Universal drivers, configure the CSL Open Database Manager (ODBM), IMS Connect, and any required ODBM, IMS Connect, or Base Primitive Environment (BPE) user exits, and then start ODBM and IMS Connect.

About this task

The following high-level summary describes the steps for configuring IMS support for the IMS Universal drivers.

Procedure

1. Configure SCI.
2. Configure IMS to join the IMSplex that you configured in the previous step.
3. Configure ODBM:
 - a) Use the ODBM configuration member of the IMS PROCLIB data set (CSLDCxxx) to define the connections between ODBM and one or more datastores.
 - b) Use the ODBM initialization member of the IMS PROCLIB data set (CSLDIxxx) to specify parameters that initialize the ODBM address space.
 - c) Use the BPE configuration member of the IMS PROCLIB data set to define the BPE execution environment settings for ODBM.
4. Optional: Write CSL ODBM user exit routines to customize and monitor the ODBM environment, and then define these user exit routines to BPE:
 - a) Write CSL ODBM user exits to customize and monitor the ODBM environment.
 - b) Specify the ODBM user exit routine in the BPE exit list member of the IMS PROCLIB data set.
 - c) Specify the BPE exit list member in the BPE configuration parameter member of the IMS PROCLIB data set.
5. Configure IMS Connect to communicate with ODBM.

Use the ODACCESS statement of the IMS Connect configuration member of the IMS PROCLIB data set (HWSCFGxx) to define characteristics of the communication between ODBM and IMS Connect.
6. Use the BPE configuration member of the IMS PROCLIB data set to define the BPE execution environment settings for IMS Connect.
7. Optional: Write IMS Connect user exit routines to configure the connection to ODBM, and then define these user exit routines to BPE:
 - a) Use the routing exit HWSROUT0 to override the IMS alias or select an ODBM.
 - b) Use the IMS Connect DB security user exit routine, HWSAUTH0, to authenticate the input user ID and password specified by IMS Connect clients.
 - c) Specify the IMS Connect user exit routines in the BPE exit list member of the IMS PROCLIB data set.
 - d) Specify the BPE exit list member in the BPE configuration parameter member of the IMS PROCLIB data set.
8. Optional: Set up tracing for the BPE-managed ODBM address space.
9. Set up security for ODBM.
10. Set up security for IMS Connect.
11. Develop and deploy applications by using the IMS Universal drivers.

You can also set up and deploy from external environments.
12. Start the following components:

- a) Start the Structured Call Interface (SCI).
- b) Start the Operations Manager (OM).
- c) If SCI is newly enabled for IMS, restart IMS.
- d) Start the IMS control region.
- e) Start ODBM.
- f) Start IMS Connect.

Related concepts

[“Defining IMS Connect security” on page 300](#)

Properly defining security for IMS Connect using RACF, and assigning IMS Connect z/OS UNIX System Services superuser privileges ensures that IMS Connect can open ports.

[How to start the IMS control region \(Operations and Automation\)](#)

[“Sample JCL to start IMS Connect” on page 297](#)

You can use this sample JCL to start IMS Connect as a z/OS procedure or job.

Related tasks

[“Setting up tracing for BPE-managed address spaces” on page 345](#)

The member of the IMS PROCLIB data set that you specify using the BPECFG= parameter in the execution parameters for the BPE-managed address spaces defines configuration parameters to the Base Primitive Environment (BPE), including trace levels.

[IMS Universal drivers: WebSphere Application Server type-4 connections \(Communications and Connections\)](#)

[Starting the CSL SCI \(Operations and Automation\)](#)

[Starting the CSL OM \(Operations and Automation\)](#)

[Starting the CSL ODBM \(Operations and Automation\)](#)

Related reference

[“CSLDCxxx member of the IMS PROCLIB data set” on page 706](#)

Use the Open Database Manager (ODBM) configuration member of the IMS PROCLIB data set (CSLDCxxx) to define the data store connections between one or more ODBM instances and one or more IMS systems.

[“CSLDIxxx member of the IMS PROCLIB data set” on page 711](#)

Use the ODBM initialization member of the IMS PROCLIB data set (CSLDIxxx) to specify parameters that initialize the ODBM address space.

[“CSLODBM procedure ” on page 595](#)

Use the CSLODBM procedure to dynamically override the settings in the ODBM initialization parameters member of the IMS PROCLIB data set (CSLDIxxx).

[“BPE configuration parameter member of the IMS PROCLIB data set” on page 665](#)

Use the BPE configuration parameter member of the IMS PROCLIB data set to define BPE execution environment settings such as tracing, language, and statistics time interval settings for an address space that is being started.

[“BPE exit list members of the IMS PROCLIB data set” on page 684](#)

Use the members of the IMS PROCLIB data set specified by the EXITMBR= parameter in the BPE configuration parameter member of the IMS PROCLIB data set to define user exit routines to BPE.

[“HWSCFGxx member of the IMS PROCLIB data set” on page 917](#)

Use the IMS Connect configuration member of the IMS PROCLIB data set, HWSCFGxx, to specify environmental settings for IMS Connect.

[CSL ODBM user exit routines \(Exit Routines\)](#)

[IMS Connect DB Routing user exit routine \(HWSROUTO\) \(Exit Routines\)](#)

[IMS Connect DB security user exit routine \(HWSAUTHO\) \(Exit Routines\)](#)

Chapter 13. IMS-to-IMS TCP/IP connections

TCP/IP connections between two IMS systems are defined by IMS Connect configuration statements and other IMS system definition macros or PROCLIB members that are required by the IMS communications component that uses the TCP/IP connection.

About this task

Each defined connection between two IMS Connect instances supports sending primary communications messages only one way. To establish a TCP/IP connection from the remote IMS system back to the local IMS system, a separate TCP/IP connection must be defined from the remote IMS system back to the local IMS system.

A complete connection between two IMS systems has three sections:

- The connection between the sending IMS system and the sending IMS Connect instance. This section is not a TCP/IP connection, but rather a communications method managed by either the Structured Call Interface (SCI) of an IMSplex or the z/OS cross-system coupling facility (XCF). IMS Multiple Systems Coupling (MSC) communications uses SCI. IMS Open Transaction Manager Access (OTMA) communications uses XCF.
- The connection between the sending and receiving IMS Connect instances. This section is a TCP/IP connection.
- The connection between the receiving IMS Connect instance and the receiving IMS system. This section is managed by either SCI or XCF.

Depending on whether the TCP/IP connection is used for MSC or OTMA communications, the steps for defining the connection differ.

The following figure shows an example IMS-to-IMS TCP/IP communications configuration.

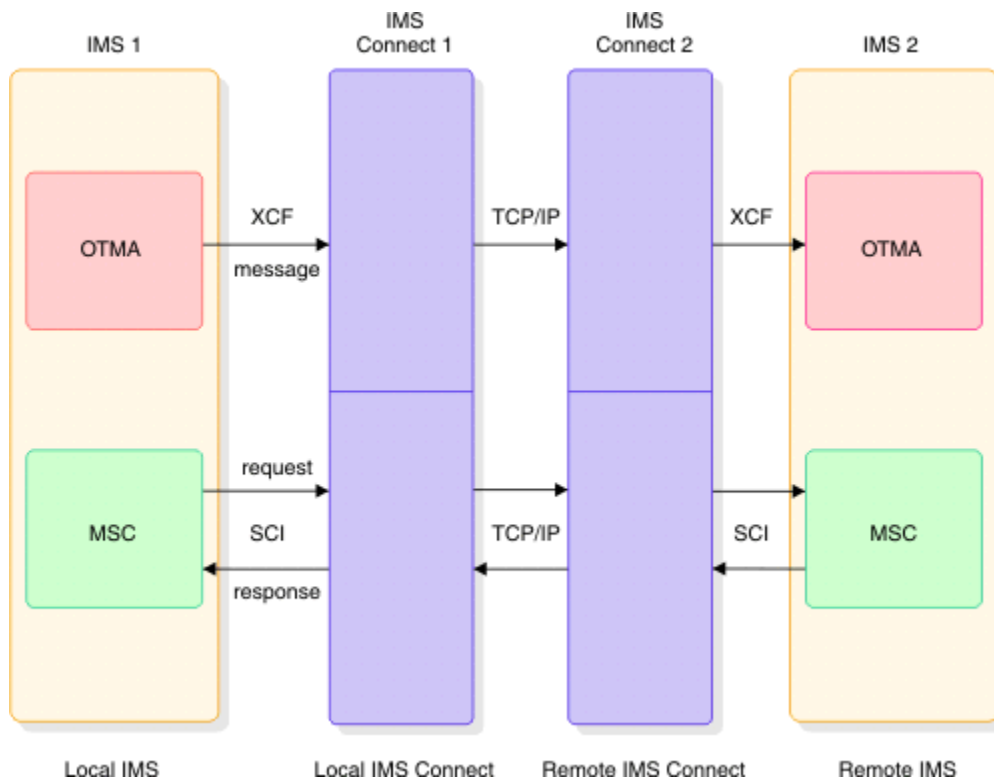

Figure 20. Example configuration for IMS-to-IMS TCP/IP communications

Defining IMS-to-IMS TCP/IP connections for MSC

Defining IMS-to-IMS TCP/IP connections for MSC requires defining MSC and IMS Connect and enabling a minimally configured IMSplex at each end of an MSC link.

About this task

Except when defining the MSC physical link, the process for defining MSC in the two IMS systems is the same as it is for any MSC link, without regard to the use of TCP/IP as the physical link type.

These instructions assume a general understanding of the system definition process for IMS, MSC, and IMS Connect, as well as an understanding of how to enable and start an IMSplex.

To simplify the following steps, the instructions refer to two IMS installations: an IMS1 installation and an IMS2 installation. The installations are at separate geographical locations. The IMS1 installation includes an IMS system, IMS1, an IMS Connect instance, HWS1, and an IMSplex, PLEX1. Similarly, the IMS2 installation includes an IMS2, an HWS2, and a PLEX2.

To define an IMS-to-IMS TCP/IP connection for an MSC link between two IMS systems, complete the following steps outlined for IMS1 and IMS2.

Procedure

1. If an IMSplex is not already enabled at the IMS1 installation, enable IMS1 for an IMSplex and bring up PLEX1 by starting instances of the Structured Call Interface (SCI) and Operations Manager (OM) components of the IMS Common Service Layer (CSL). The SCI instance must be in the same logical partition as IMS1.
2. In IMS1, code the MSC definitions, including at least one physical link and one logical link.

When coding the MSPLINK macro to define the MSC physical link, the following summarized values are used for the TCP/IP physical link type:

Label field

Defines the name of the physical link to IMS1. The physical link name is used when assigning logical links and when issuing commands against the physical link.

LCLICON

The name that HWS1 registers with SCI in PLEX1. This name is also specified on the MEMBER parameter of the IMSPLEX substatement on MSC configuration statement for HWS1.

LCLPLKID

The ID of the MSC configuration statement that defines the MSC physical link to HWS1. This value must match the value specified on the LCLPLKID keyword of the MSC configuration statement for HWS1.

NAME

The IMS ID of IMS2.

TYPE

Specify TCPIP

3. In HWS1, code the following required configuration statements:

HWS

To enable HWS1 to authenticate RACF PassTickets sent by HWS2 on incoming TCP/IP connections, specify RACF=Y.

TCPIP

The value specified on either the PORT or PORTID keyword of the HWS1 TCPIP statement is also specified on the PORT keyword of the HWS2 RMTIMSCON statement.

RMTIMSCON

The RMTIMSCON statement defines the TCP/IP connection from HWS1 to HWS2.

At a minimum, you must define the following keywords of the RMTIMSCON statement:

ID

Uniquely identifies this connection. The ID value must also be specified on the RMTIMSCON keyword on the HWS1 MSC configuration statement.

IPADDR or HOSTNAME

Identifies the internet address of the receiving IMS Connect instance

PORT

Identifies the port that the receiving IMS Connect instance uses for this connection. This value must match the value specified on either the PORT or PORTID keyword in the HWS2 TCPIP configuration statement.

Optionally, specify the following additional parameters:

APPL

If HWS2 is configured to authenticate RACF PassTickets that are provided with incoming MSC TCP/IP connections, you must specify both the APPL and USERID parameters.

PERSISTENT

Although it is not required for MSC connections, code PERSISTENT=Y to avoid receiving a warning message when IMS Connect changes the default value during each start up.

RESVSOC

Reserves send sockets for the MSC logical links that use this TCP/IP connection. The corresponding receive sockets that are required by MSC logical links are not reserved.

Specify a number equal to the maximum number of MSC logical links sessions that will use this physical link.

In the PROCLIB configuration member for HWS1, the sum of all of the RESVSOC values in all RMTIMSCON statements cannot exceed the total value of the MAXSOC parameter in the TCPIP statement.

USERID

If HWS2 is configured to authenticate RACF PassTickets that are provided with incoming MSC TCP/IP connections, you must specify both the USERID and APPL parameters.

MSC

The MSC configuration statement defines the communications path from IMS1 to IMS2 through HWS1 and HWS2.

All of the following keywords of the MSC statement are required:

LCLPLKID

Identifies the MSC statement that defines the physical link to HWS1. This value must match the value specified on the LCLPLKID parameter of the MSPLINK system definition macro that defines the physical link to IMS1. HWS2 specifies this value on the RMTPLKID parameter of the MSC statement.

RMTPLKID

The ID of the MSC statement that defines the physical link to HWS2. The value must match the value specified on both the LCLPLKID parameter of the MSC statement of HWS2 and the LCLPLKID parameter of the MSPLINK macro of IMS2.

IMSPLEX=(MEMBER=*imsconnectname* , TMEMBER=(*imsplexname*))

Joins HWS1 to PLEX1 to enable MSC communications between HWS1 and IMS1. If an IMSplex configuration statement joins IMS Connect to PLEX1 already, the IMSPlex substatement can be omitted from the MSC statement.

LCLIMS

The IMS ID of IMS1 as registered with SCI in the IMSplex. The IMS ID must be enclosed in parentheses, for example: LCLIMS=(IMS1).

RMTIMS

The IMS ID of IMS2 as registered with SCI in PLEX2.

RMTIMSCON

The name of the connection between IMS1 and IMS2 that is to be used for this MSC physical link, as defined on the ID parameter of the RMTIMSCON statement of IMS1.

4. If an IMSplex is not already enabled at the IMS2 installation, enable IMS2 for an IMSplex and bring up PLEX2 by starting instances of the SCI and OM CSL components. The SCI instance must be in the same logical partition as IMS2.
5. In IMS2, code the MSC definitions.

When coding the MSPLINK macro to define the MSC physical link, the following values are specific to the TCP/IP physical link type:

Label field

Defines the name of the physical link to IMS2. The physical link name is used when assigning logical links and when issuing commands against the physical link.

LCLICON

The name that HWS2 registers with SCI in PLEX2. This name is also specified on the MEMBER parameter of the IMSPLEX substatement on MSC configuration statement for HWS2.

LCLPLKID

The ID of the MSC configuration statement that defines the MSC physical link to HWS2. This value must match the value specified on the LCLPLKID keyword of the MSC configuration statement for HWS2.

NAME

The IMS ID of IMS1.

TYPE

Specify TCPIP

6. In HWS2, code the following required configuration statements:

HWS

This configuration statement is required by IMS Connect.

To enable HWS2 to authenticate RACF PassTickets sent by HWS1 on incoming TCP/IP connections, specify RACF=Y.

TCPIP

This configuration statement is required by IMS Connect.

The value specified on either the PORT or PORTID keyword of the HWS2 TCPIP statement is also specified on the PORT keyword of the HWS1 RMTIMSCON statement.

RMTIMSCON

The RMTIMSCON statement defines the TCP/IP connection from HWS2 to HWS1.

At a minimum, you must define the following keywords of the RMTIMSCON statement:

ID

Uniquely identifies this connection. The ID value must also be specified on the RMTIMSCON keyword on the HWS2 MSC configuration statement.

IPADDR or HOSTNAME

Identifies the internet address of the receiving IMS Connect instance

PORT

Identifies the port that HWS1 uses for this connection. This value must match the value that is specified on either the PORT or PORTID keyword in the HWS1 TCPIP configuration statement.

Optionally, specify the following additional parameters:

APPL

If HWS1 is configured to authenticate RACF PassTickets that are provided with incoming MSC TCP/IP connections, you must specify both the APPL and USERID parameters.

PERSISTENT

Although it is not required for MSC connections, code PERSISTENT=Y to avoid receiving a warning message when IMS Connect changes the default value during each start up.

RESVSOC

Reserves send sockets for the MSC logical links that use this TCP/IP connection. The corresponding receive sockets that are required by MSC logical links are not reserved.

Specify a number equal to the maximum number of MSC logical links sessions that will use this physical link.

In the configuration member for HWS2, the sum of all of the RESVSOC values in all RMTIMSCON statements cannot exceed the total value of the MAXSOC parameter in the TCPIP statement.

USERID

If HWS1 is configured to authenticate RACF PassTickets that are provided with incoming MSC TCP/IP connections, you must specify both the USERID and APPL parameters.

MSC

For HWS2, the MSC configuration statement defines the communications path from IMS2 to IMS1 through HWS2 and HWS1.

All of the following keywords of the MSC statement are required:

LCLPLKID

Identifies the MSC statement that defines the physical link to HWS2. This value must match the value specified on the LCLPLKID parameter of the MSPLINK system definition macro that defines the physical link to IMS2. HWS1 specifies this value on the RMTPLKID parameter of the MSC statement.

RMTPLKID

The ID of the MSC statement that defines the physical link to HWS1. The value must match the value specified on both the LCLPLKID parameter of the MSC statement of HWS1 and the LCLPLKID parameter of the MSPLINK macro of IMS1.

IMSPLEX=(MEMBER=*imsconnectname* , TMEMBER=(*imsplexname*))

Joins HWS2 to PLEX2 to enable MSC communications between HWS2 and IMS2. If an IMSplex configuration statement joins IMS Connect to PLEX2 already, the IMSplex substatement can be omitted from the MSC statement.

LCLIMS

The IMS ID of IMS2 as registered with SCI in the IMSplex. The IMS ID must be enclosed in parentheses, for example: LCLIMS=(IMS2).

RMTIMS

The IMS ID of IMS1 as registered with SCI in PLEX1.

RMTIMSCON

The name of the connection between IMS2 and IMS1 that is to be used for this MSC physical link, as defined on the ID parameter of the RMTIMSCON statement of IMS2.

What to do next

After the MSC links and TCP/IP connections have been defined and both IMSplexes have been started, start communications between IMS1 and IMS2. To start communications, issue either the IMS type-1 command **/RSTART LINK** or the IMS type-2 command **UPDATE MSLINK NAME(linkname) START(COMM)** in each system.

Related concepts

[“CSL definition and tailoring” on page 245](#)

You can define the Common Service Layer using several IMS PROCLIB data sets; after they are defined, they should be started in a specific sequence.

[“IMS Connect definition and tailoring” on page 297](#)

This topic describes the tasks of defining and tailoring IMS Connect. It provides detailed information about configuring and customizing the IMS Connect environment, as well as guidelines and procedures for using and invoking IMS Connect.

Related tasks

[Defining Multiple Systems Coupling resources \(Communications and Connections\)](#)

Related reference

[“HWSCFGxx member of the IMS PROCLIB data set” on page 917](#)

Use the IMS Connect configuration member of the IMS PROCLIB data set, HWSCFGxx, to specify environmental settings for IMS Connect.

[“MSPLINK macro” on page 461](#)

The MSPLINK macro defines an MSC physical link.

Example definitions for an MSC TCP/IP link

The following series of examples show the definitions required for an MSC TCP/IP link between two IMS systems.

Local MSC link definitions

The following MSC link definitions are coded in the local IMS system.

```
PLNK12TA MSPLINK
TYPE=TCPIP, NAME=IMS2, LCLICON=HWS1, LCLPLKID=MSC12, BUFSIZE=8192, SESSION=2
MSLINK PARTNER=AB
MSNAME SYSID=(2,1)
```

Local IMS Connect configuration member

The following MSC and RMTIMSCON configuration statements are coded in the local IMS Connect configuration member.

```
HWS=(ID=HWS1, XIBAREA=20, RACF=Y)
TCPIP=(HOSTNAME=TCPIP, PORTID=(9999),
MAXSOC=50, RACFID=RACFID, TIMEOUT=5000)
MSC=(LCLPLKID=MSC12, RMTPLKID=MSC21, LCLIMS=(IMS1), RMTIMS=IMS2,
IMSPLEX=(MEMBER=HWS1, TMEMBER=PLEX1), RMTIMSCON=HWS2)
RMTIMSCON=(ID=HWS2, HOSTNAME=HWS2.IBM.COM, PORT=8888, RESVSOC=2)
```

Remote IMS Connect configuration member

The following MSC and RMTIMSCON configuration statements are coded in the remote IMS Connect configuration member.

```
HWS=(ID=HWS2, XIBAREA=20, RACF=Y)
TCPIP=(HOSTNAME=TCPIP, PORTID=(8888),
MAXSOC=50, RACFID=RACFID, TIMEOUT=5000)
MSC=(LCLPLKID=MSC21, RMTPLKID=MSC12, LCLIMS=(IMS2), RMTIMS=IMS1,
IMSPLEX=(MEMBER=HWS2, TMEMBER=PLEX2), RMTIMSCON=HWS1)
RMTIMSCON=(ID=HWS1, HOSTNAME=HWS1.IBM.COM, PORT=9999, RESVSOC=2)
```

Remote MSC link definitions

The following MSC link definitions are coded in the remote IMS system.

```
PLNK21TA MSPLINK
Type=TCPIP, NAME=IMS1, LCLICON=HWS2, LCLPLKID=MSC21, BUSIZE=8192, SESSION=2
MSLINK PARTNER=AB
MSNAME SYSID=(1,2)
```

The following figure shows the IMS and IMS Connect systems at the local and remote installations. The definition statements required to define the MSC link path are shown in each IMS and IMS Connect system. Other required definition statements that are not directly related to the definition of the MSC path are omitted from the figure.

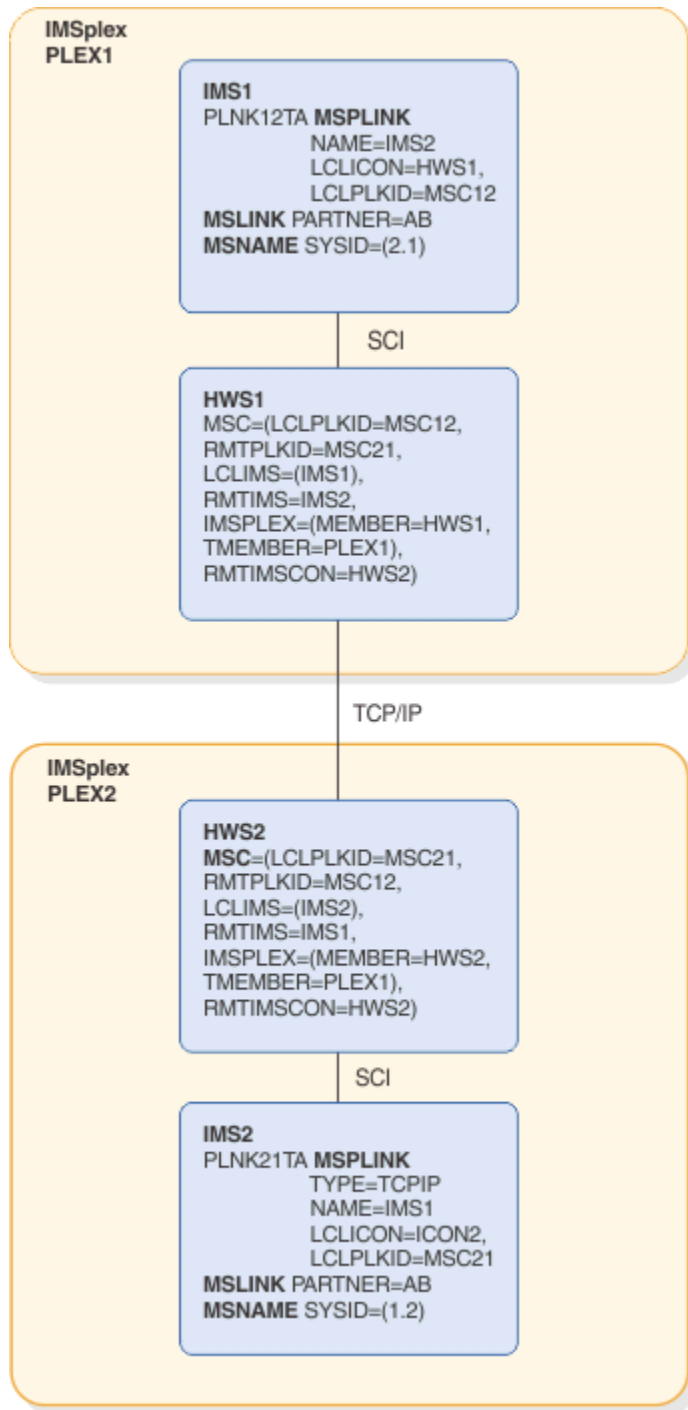

Figure 21. Example MSC TCP/IP link configuration

Defining a TCP/IP generic resource group for MSC

A TCP/IP generic resource group is defined for MSC by coding the GENIMSID parameter in both the IMS DFSDCxxx PROCLIB member and in the IMS Connect HWSCFGxx PROCLIB member.

Before you begin

Prerequisite: The following steps assume that the general system definition is already complete for IMS, IMS Connect, and the Structured Call Interface. These steps also do not cover the definition of MSC logical links, which is the same whether or not you are using TCP/IP generic resources.

About this task

The GENIMSID parameter defines a shared IMS ID that represents a group of IMS systems as a single IMS system. The MSC TCP/IP physical links that connect to a TCP/IP generic resource group specify the shared generic IMS ID of the TCP/IP generic resource group instead of specifying an IMS ID of a specific local IMS system.

TCP/IP generic resource links and non-generic TCP/IP physical links cannot coexist between the same two IMS systems. If a local IMS system is already linked to a remote IMS system by one or more non-generic TCP/IP physical links, the remote IMS system cannot connect to the local IMS system through a TCP/IP generic resource group.

Each MSC TCP/IP connection between a TCP/IP generic resource group and an outside IMS system is managed in the IMSplex by a single IMS Connect instance. MSC TCP/IP generic resources do not support the use of multiple IMS Connect instances to support the same MSC TCP/IP connection within the same MSC TCP/IP generic resource group.

Up to 936 IMS systems in an IMSplex can participate in an MSC TCP/IP generic resource group.

To define a TCP/IP generic resource group for an MSC TCP/IP connection:

Procedure

1. In the DFSDCxxx PROCLIB member of each participating IMS system in the IMSplex, specify a shared generic IMS ID on the GENIMSID parameter.

For example, GENIMSID=IMS.

2. In each IMS system in the TCP/IP generic resource group, code an MSPLINK system definition macro statement for each MSC TCP/IP physical link that will connect to the group.

Specify an ID for the physical link on the LCLPLKID parameter. Specify the ID of the local IMS Connect instance on the LCLICON parameter. All other MSPLINK parameters are specified the same as a TCP/IP physical link in a non-generic resources environment.

In non-XRF systems, except for the LCLPLKID parameter, the MSPLINK macros for the same physical link must be identical in each IMS system in the TCP/IP generic resource group. In XRF systems, the MSPLINK statement that defines a physical supported by an XRF pair would be identical in each IMS system in the XRF pair.

For example, in TCP/IP generic resource group with two non-XRF IMS systems, IMS1 and IMS2, the MSPLINK macro in IMS1 might be defined as:

```
PLNK13TA MSPLINK
        NAME=IMS3,
        LCLICON=HWS1,
        LCLPLKID=MSC13,
        TYPE=TCPIP,
        SESSION=2
```

In IMS2, the MSPLINK macro would be almost identical, except the LCLPLKID value would be different. For example:

```

PLNK13TA MSPLINK
        NAME=IMS3,
        LCLICON=HWS1,
        LCLPLKID=MSC23,
        TYPE=TCPIP,
        SESSION=2

```

3. In the HWSCFGxx PROCLIB member of the IMS Connect instance that supports the TCP/IP generic resource group, define an MSC configuration statement for each MSPLINK statement for each physical link in the TCP/IP generic resource group.

If you are using XRF, you can define a single MSC statement for a physical link that is used, alternately, by both IMS systems in the XRF pair. If you are not using XRF, you must define a separate MSC statement for each MSPLINK.

In each MSC configuration statement, specify the same ID for the physical link on the LCLPLKID parameter that you specified on the LCLPLKID parameter of the corresponding MSPLINK macro statement.

For example, for the MSPLINK statements defined for the non-XRF systems IMS1 and IMS2 in the previous step, the following MSC statements might be defined in the local IMS Connect:

```

MSC=(LCLPLKID=MSC13,RMTPLKID=MSC,LCLIMS=(IMS1),RMTIMS=IMS3,GENIMSID=IMS)
MSC=(LCLPLKID=MSC13,RMTPLKID=MSC,LCLIMS=(IMS2),RMTIMS=IMS3,GENIMSID=IMS)

```

However, if IMS1 and IMS2 were instead an XRF pair, the following MSC statement would be valid:

```

MSC=(LCLPLKID=MSC13,RMTPLKID=MSC,LCLIMS=(IMS1,IMS2),RMTIMS=IMS3,GENIMSID=IMS)

```

4. On the remote IMS system, specify one MSPLINK macro to define the TCP/IP physical link that will connect to the TCP/IP generic resource group.

Other than specifying the shared generic IMS ID on the NAME parameter, no special coding is required in the MSPLINK macro for TCP/IP generic resources. The remote IMS system is unaware that TCP/IP generic resources are used.

For example, the IMS system, IMS3, that is connecting to the TCP/IP generic resource group could code the following MSPLINK statement:

```

PLNK31TA MSPLINK
        NAME=IMS,
        LCLICON=HWS2,
        LCLPLKID=MSC,
        TYPE=TCPIP,
        SESSION=2

```

5. In the HWSCFGxx PROCLIB member of the remote IMS Connect instance, define an MSC configuration statement to correspond to the MSPLINK statement in IMS3.

Specify the shared generic IMS ID of the TCP/IP generic resource group on the RMTIMS parameter of the MSC statement. Specify the ID of the physical link from any MSPLINK macro in the TCP/IP generic resource group on the RMTPLKID parameter.

For example, if the ID of the physical link in the TCP/IP generic resource group is MSC13 in IMS1 and MSC23 in IMS2, you can specify either MSC13 or MSC23 on the RMTPLKID parameter of the MSC statement in the remote IMS Connect. In the following MSC statement MSC13 is specified:

```

MSC=(LCLPLKID=MSC,RMTPLKID=MSC13,LCLIMS=(IMS3),RMTIMS=IMS)

```

Results

To determine if TCP/IP generic resources are active, you can issue the **/DISPLAY ACT** DC command.

After MSC TCP/IP generic resources are enabled, if the remote IMS system starts the link, the first IMS system in the TCP/IP generic resource group to respond to IMS Connect accepts the start request. After the link request is accepted, the logical link has affinity to the IMS system that accepted the link request.

If a logical link is started from an IMS system within the TCP/IP generic resource group, the link has affinity with the specific IMS system from which the link was started.

A logical link with affinity cannot be moved to another IMS system without terminating all logical links on the physical link.

You can control which IMS system in a TCP/IP generic resource group accepts a link request by stopping logons to the physical link in all IMS systems in the group, except in the one IMS system with which affinity is required. The following commands stop logons to physical links on IMS systems in a TCP/IP generic resource group:

- The IMS type-2 command **UPDATE MSPLINK** NAME(*linkname*) STOP(GENLOGON)
- The IMS type-1 command **/PSTOP MSPLINK**

After affinity has been established, you can confirm which IMS system has affinity by issuing any of the following commands:

- **/DISPLAY AFFIN LINK**
- **QUERY IMS**
- **QUERY MSLINK**

Example

The following figure shows the TCP/IP generic resource group defined by the preceding example definitions.

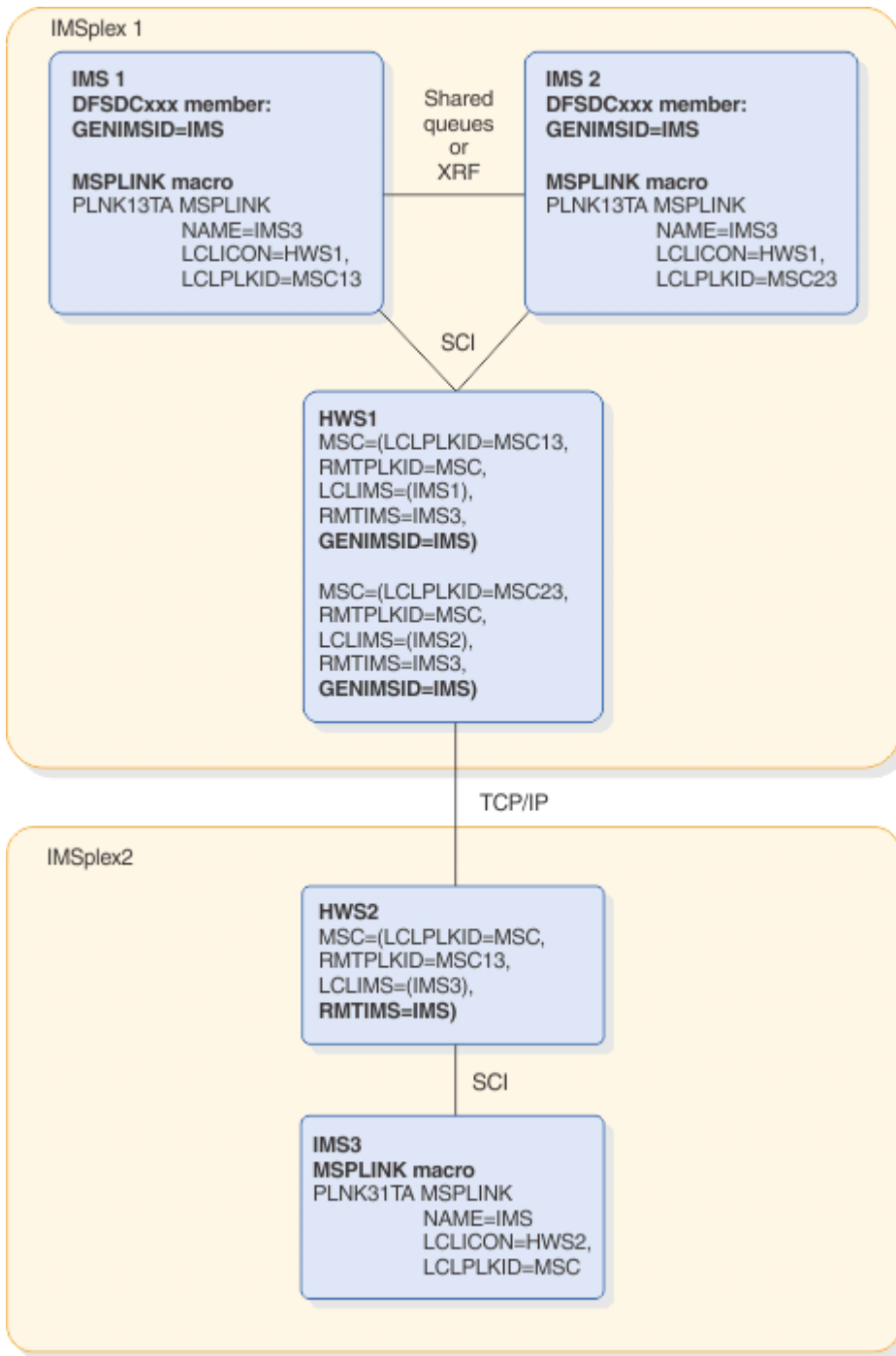

Figure 22. Example of system definition statements for an MSC TCP/IP generic resource group

Related concepts

MSC TCP/IP generic resources (Communications and Connections)

Related reference

“MSC statement” on page 932

The MSC statement defines a one-way send path for an MSC physical link between a local IMS system to a remote IMS system.

“MSPLINK macro” on page 461

The MSPLINK macro defines an MSC physical link.

“DFSDCxxx member of the IMS PROCLIB data set” on page 736

Use the DFSDCxxx member of the IMS PROCLIB data set to define data communication options.

Defining IMS-to-IMS TCP/IP connections for OTMA

Defining IMS-to-IMS TCP/IP connections for OTMA requires defining the destination for the ALTPCB output messages and defining the TCP/IP connection in IMS Connect.

About this task

An IMS-to-IMS TCP/IP connection delivers OTMA messages in only one direction. Any response messages are queued to a tpipe hold queue for asynchronous retrieval.

To send response messages or other transaction messages from the remote IMS installation back to the local IMS installation, a separate TCP/IP connection must be defined at the remote installation. The correlation of any response messages that are returned this way with the original transaction must be managed by your installation.

To define an IMS-to-IMS TCP/IP connection for OTMA messages:

Procedure

1. For the local IMS Connect instance, define the IMS-to-IMS TCP/IP connection by coding the following required IMS Connect configuration statements in the IMS.PROCLIB data set of the local IMS installation:

HWS

This configuration statement is required by IMS Connect.

TCPIP

This configuration statement is required by IMS Connect.

DATASTORE

This configuration statement is required by IMS Connect for communication with OTMA.

RMTIMSCON

The RMTIMSCON statement defines the TCP/IP connection from the local IMS Connect instance to the remote IMS Connect instance.

At a minimum, you must define the following keywords of the RMTIMSCON statement:

ID

Uniquely identifies this connection. The ID value must also be specified on the RMTIMSCON keyword on the OTMA destination descriptor.

IPADDR or HOSTNAME

Identifies the internet address of the receiving IMS Connect instance

PORT

Identifies the port that the receiving IMS Connect instance uses for this connection. This value must match the value specified on either the PORT or PORTID keyword in the TCPIP configuration statement of the remote IMS Connect instance.

Optionally, specify the following additional parameters:

APPL

If the remote IMS Connect instance is configured to authenticate RACF PassTickets (RACF=Y is specified on the remote HWS configuration statement), you must specify both the APPL and the USERID parameters.

AUTOCONN

Determines whether local IMS Connect automatically establishes the connection with the remote IMS Connect instance during startup.

IDLETO

Specifies the amount of time open socket connections can remain idle before they are terminated due to inactivity.

PERSISTENT

Defines the connection as persistent.

Recommendation: Specify PERSISTENT=Y to reduce the usage of storage at the remote IMS installation. When persistent socket connections are used, less storage is used because the remote OTMA creates fewer tpipes.

RESVSOC

The number of send sockets that IMS Connect reserves for use by this connection.

USERID

If the remote IMS Connect instance is configured to authenticate RACF PassTickets (RACF=Y is specified on the remote HWS configuration statement), you must specify both the USERID and the APPL parameters.

2. Code an OTMA destination descriptor in the IMS.PROCLIB data set of the local IMS system.

At a minimum, you must code the following parameters:

RMTIMS

The name of the remote IMS system. The value specified on RMTIMS must match the name defined to the remote IMS Connect instance on the ID parameter of the DATASTORE statement at the remote installation.

RMTIMSCON

The name of the IMS-to-IMS TCP/IP connection to use, as defined on the ID parameter of the RMTIMSCON statement of the local IMS Connect instance.

TMEMBER

The z/OS cross-system coupling facility (XCF) member name of the local IMS Connect instance, as specified on the MEMBER parameter of the DATASTORE statement of the local IMS Connect instance.

TYPE

Specify TYPE=IMSCON.

In addition to the RMTIMS, TMTIMSCON, and TMEMBER parameters, specify any optional parameters in the OTMA destination descriptor.

3. Optionally, specify the amount of time that OTMA waits for acknowledgements by coding an OTMA client descriptor with the T/O parameter.
4. At the local IMS installation, modify the IMS application program that sends the transaction message to the remote IMS installation to:
 - a) Specify the name of the OTMA destination descriptor as the destination when the application program issues the CHNG call.
 - b) Issue an ISRT ALTPCB call to send the transaction message.
5. Configure the remote IMS Connect instance by specifying the following required configuration statements:

HWS

To enable the remote IMS Connect instance to authenticate RACF PassTickets on incoming TCP/IP connections from the local IMS installation, specify RACF=Y.

TCPIP

The value specified on either the PORT or PORTID keyword of the remote TCPIP statement must be specified on the PORT keyword of the RMTIMSCON statement of the local IMS Connect instance.

DATASTORE

This configuration statement is used for communication with OTMA.

6. Optional: Specify a RMTIMSCON statement for the remote IMS Connect instance if you need an IMS-to-IMS TCP/IP connection to send messages from the remote IMS installation back to the local IMS installation.

Related concepts

[“IMS Connect definition and tailoring” on page 297](#)

This topic describes the tasks of defining and tailoring IMS Connect. It provides detailed information about configuring and customizing the IMS Connect environment, as well as guidelines and procedures for using and invoking IMS Connect.

Related reference

[“HWSCFGxx member of the IMS PROCLIB data set” on page 917](#)

Use the IMS Connect configuration member of the IMS PROCLIB data set, HWSCFGxx, to specify environmental settings for IMS Connect.

[“OTMA destination descriptor syntax and parameters” on page 895](#)

Use OTMA destination descriptors to define message switch destinations from the ALT IOPCB for OTMA clients, such as IMS Connect or IBM MQ, or non-OTMA clients, such as SNA terminals or printers. The OTMA destination descriptors can also be used to define destinations for synchronous callout messages and messages that are destined for remote IMS systems on a TCP/IP connection.

[Summary of the OTMA configuration parameters \(Communications and Connections\)](#)

Example definitions for sending OTMA messages to a remote IMS system

The following examples show the OTMA descriptors and IMS Connect configuration statements used to send OTMA messages to a remote IMS system.

The values shown in each of the examples correspond to the values shown in all of the other examples in this series.

OTMA descriptor definitions

In the following example, both an OTMA client descriptor and an OTMA destination descriptor are coded in the local IMS.PROCLIB data set.

The OTMA client descriptor, which is preceded by an M, defines a timeout value for acknowledgments. The OTMA destination descriptor, which is preceded by a D, defines the remote destination.

```
M ICON1          T/O=60
D DESC1 TYPE=IMSCON TMEMBER=ICON1 RMTIMSCON=ICON2 RMTIMS=IMS2
```

IMS Connect definitions

The following IMS Connect configuration statements are coded in the local IMS system.

```
HWS=(ID=ICON1,XIBAREA=100,RACF=N)
TCPIP=(HOSTNAME=TCPIP,PORTID=(8888),
MAXSOC=50,TIMEOUT=5000)
DATASTORE=(ID=IMS1,GROUP=XCFGRP1,MEMBER=ICON1,
TMEMBER=IMS1,DRU=HWSYDRU0,APPL=APPLID1)
RMTIMSCON=(ID=ICON2,HOSTNAME=ICON2.IBM.COM,
PORT=9999,AUTOCONN=N,PERSISTENT=Y,IDLETO=60000,RESVSOC=10)
```

Defining an IMS Connect super member group for OTMA IMS-to-IMS TCP/IP connections

Using a super member group, you can configure OTMA to send output messages to a remote IMS installation through up to eight local instances of IMS Connect.

About this task

The use of a super member group is transparent to both the IMS application that sends the messages and the remote IMS installation that receives the messages.

The following figure illustrates the use of a super member group with an IMS-to-IMS TCP/IP connection.

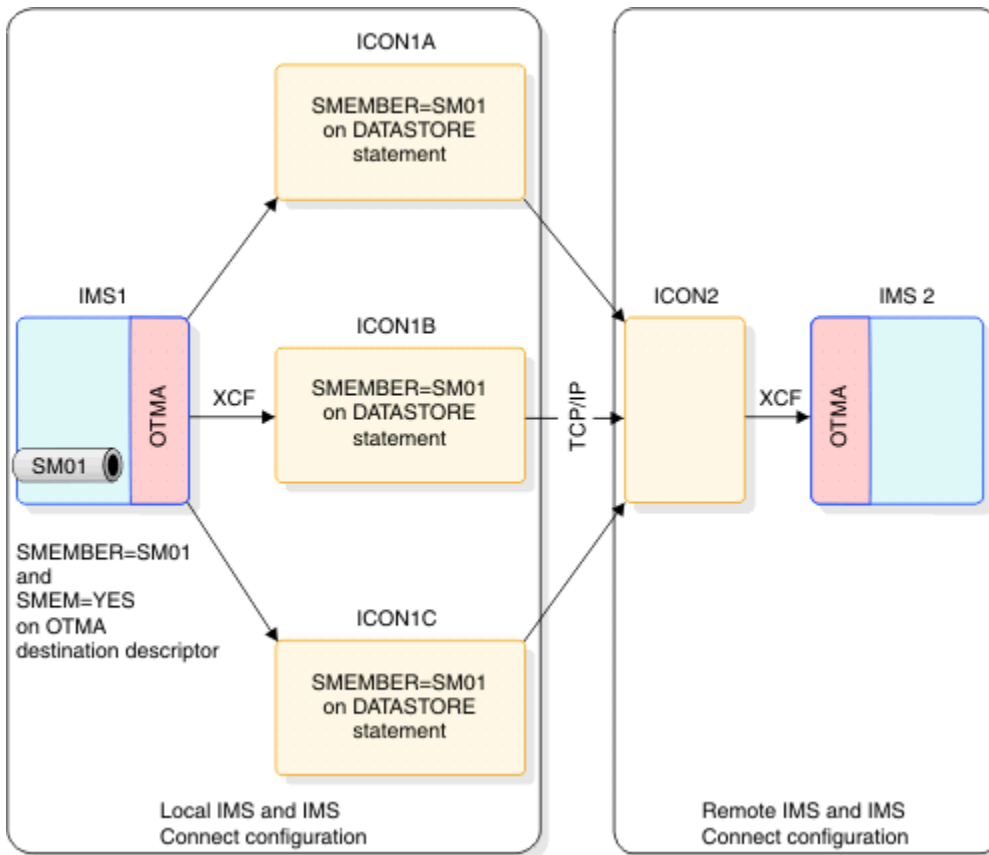

Figure 23. Using a super member group with OTMA IMS-to-IMS TCP/IP connections

To configure a super member group to send OTMA ALTPCB messages to a remote IMS installation by way of an IMS-to-IMS TCP/IP connection:

Procedure

1. Define an OTMA destination descriptor in the DFSYDTx member of the IMS.PROCLIB data set that includes the following specifications:
 - SMEM=YES, to enable a super member group.
 - TMEMBER=*super_member_name*, to name the super member group. For example, TMEMBER=SM01.
2. In the IMS.PROCLIB data set, specify SMEM=*super_member_name* in the DATASTORE statement of the configuration member for each local IMS Connect instance that participates in the super member group. For example, if the super member group is named SM01, specify SMEM=SM01 for each IMS Connect instance.
3. Modify the IMS application program to specify the OTMA destination descriptor that you defined as the destination for the output messages that it sends to the remote IMS system.

Results

After the super member group is defined and the IMS application begins sending output messages, OTMA distributes the output messages to each participating IMS Connect instance in turn by using a round-robin algorithm.

OTMA dynamically updates the super member round robin list each time an IMS Connect instance joins or leaves the super member group.

Related reference

[“HWSCFGxx member of the IMS PROCLIB data set” on page 917](#)

Use the IMS Connect configuration member of the IMS PROCLIB data set, HWSCFGxx, to specify environmental settings for IMS Connect.

[“OTMA destination descriptor syntax and parameters” on page 895](#)

Use OTMA destination descriptors to define message switch destinations from the ALT IOPCB for OTMA clients, such as IMS Connect or IBM MQ, or non-OTMA clients, such as SNA terminals or printers. The OTMA destination descriptors can also be used to define destinations for synchronous callout messages and messages that are destined for remote IMS systems on a TCP/IP connection.

Chapter 14. Accessing external subsystem data

These topics describe the installation and definition tasks that you need to perform if you are an IMS user that wants to access external subsystem data, such as data that resides in Db2 for z/OS.

Defining your external subsystems to IMS

In order for IMS to initiate contact with an external subsystem, you must add a subsystem member (SSM) to the IMS PROCLIB data set for each external subsystem with which IMS communicates.

This SSM contains an entry for each external subsystem with which IMS communicates. In the case of Db2 for z/OS with several possible definitions for the same Db2 for z/OS system, the member contains one access for Java regions in IMS and the other for other region types. When defining Db2 for z/OS databases, this member contains one entry for each Db2 for z/OS subsystem, or an entry that defines a group of Db2 for z/OS subsystems.

You can also establish simultaneous access to the same Db2 for z/OS subsystem if the IMS PROCLIB data set member contains a definition for both connections.

Define the SSM PROCLIB member (or members) using the IMS PROCLIB data set that is allocated before Stage 2 of IMS system definition and the z/OS utility IEBUPDTE. The first 1 - 4 characters of this PROCLIB member's name must match the IMSID, as specified by the IMSID parameter on the IMSCTRL macro statement, or it must be overridden using the execution parameter IMSID=. The last four positions represent any unique installation-defined identifier. This identifier is appended to the IMSID to construct the member name.

After defining the SSM PROCLIB member, before you can use it you must:

1. Insert a DD statement for IMS PROCLIB with the DD name PROCLIB in the step execution JCL.
2. Specify the correct PROCLIB member on the EXEC statement parameter SSM= or on the /START SUBSYS SSM command.

Each entry within the PROCLIB member consists of a blocked or unblocked 80-character record. Information for each record begins in position 1 of the record.

An SSM PROCLIB member can contain either positional-format statements in a fixed order, or keyword-format statements in a semi-fixed order.

Restriction: A single subsystem definition cannot use both positional and keyword parameters simultaneously.

Positional format

Fixed parameter format. Keywords are not allowed. Values must be entered in the following order: *ssn, lit, esmt, rtt, reo, crc*.

For example,

```
V10A, SYS1, DSNMIN10, RTTDB2A, R, -
```

Keyword format

Keyword-only, and must begin with SST=. After SST=, most values can be specified in any order:

```
SST=, SSN=, LIT=, ESMT=, RTT=, REO=, CRC=, RLA=
```

For example,

```
SST=DB2, SSN=DB21, LIT=SYS1, ESMT=DSNMIN10, REO=R, CRC=-, RLA=Y
```

If COORD is specified, only SST= and SSN= may also be specified; all other keywords are ignored:

```
SST=, SSN=, COORD=
```

For example,

```
SST=DB2,SSN=DB21,LIT=SYS1,ESMT=DSNMIN10,REO=R,CRC=-
```

```
SST=DB2,CRC=-,REO=R,ESMT=DSNMIN10,LIT=SYS1,SSN=DB21
```

```
SST=MQ,SSN=SYS3,LIT=MQM3,ESMT=CSQQESMT
```

```
SST=DB2,SSN=V71A,C00RD=RRS
```

The SSM member can contain two keyword-only parameters, SST= and COORD=. These parameters cannot be specified positionally. The COORD= parameter specifies the type of resource coordination controller, such as RRS. The SST= parameter specifies the type of external subsystem.

On the SST= parameter, the valid external subsystem types are:

DB2

Db2 for z/OS

MQ

IBM MQ

WOLA

WebSphere® Optimized Local Adapter



Attention: If you define the subsystem in positional format, IMS displays DB2 as the ESS type in both command responses and DFS messages even if you are using MQ or WOLA.

Specifying the SSM= EXEC parameter

Use the SSM= EXEC parameter to indicate which member of the IMS PROCLIB data set contains an entry for the external subsystem you want to attach.

Use the SSM= EXEC parameter to indicate which member of the IMS PROCLIB data set contains an entry for the external subsystem you want to attach. You can specify the SSM= EXEC parameter on the EXEC procedures of that control region, or for an MPP, BMP, IFP, JMP, or JBP-dependent region.

The SSM= EXEC parameter is required for an MPP, BMP, IFP, JMP, or JBP region when the subsystem member defines a Db2 for z/OS group.

If the SSM= EXEC parameter is not specified when the IMS subsystem is initialized, the ESAF or RRSF component is not activated. You can later activate the ESAF component and enable external subsystem support in one of two ways:

- Shut down IMS and restart it, specifying the SSM= EXEC parameter.
- Use the /START SUBSYS SSM command to inform IMS of the subsystem member. This action activates the ESAF component and attempts a connection to the external subsystems defined in the SSM member of the IMS PROCLIB data set.

Restriction: You can activate the RRSF component and enable Db2 for z/OS support only by shutting down IMS and restarting it with the SSM= EXEC parameter specified.

For an MPP or an IFP dependent region that is currently active but not connected, you must stop and start the region for a connection for that dependent region.

When SSM= is specified for the control region, any dependent region running under the control region can attach to the external subsystems named in the member of the IMS PROCLIB data set pointed to by the SSM= parameter.

When SSM= is specified for an MPP, BMP, or IFP region, it provides a filter that determines whether a given application program running in that dependent region can access external subsystem resources. Only the subsystems defined in the subsystem member can be connected to the dependent region. If a subsystem is defined in the named dependent region member, but not in the control region member,

a message is sent to the MTO during dependent region initialization and a subsystem connection is not made for this dependent region entry.

For example, if a subsystem entry for a given Db2 for z/OS subsystem exists in the named dependent region member, but not in the control region member, then a message is sent to the MTO during dependent region initialization and a subsystem connection is not made for this dependent region entry.

If SSM is specified on the control region but the installation wants a particular dependent region to be prohibited from attaching to any external subsystem, a member of the IMS PROCLIB data set must be created having no entries, and its ID specified in the dependent region. Application programs in this dependent region cannot attach to any external subsystem.

When the member of the IMS PROCLIB data set contains a null record, you receive the following informational message:

```
DFS3600I UNABLE TO INITIATE THE EXTERNAL SUBSYSTEM TABLE, RC=36
```

If an invalid member name is specified or if the record format is incorrect, no external subsystem is attached, but initialization continues. You can then enter the **/START SUBSYS SSM** command, specifying the correct subsystem name. If the **/START SUBSYS SSM** command is issued with an invalid subsystem member name, re-enter the command with a valid name.

Restriction: You cannot use the **/START SUBSYS SSM** command for external subsystems attached by RRSAF. If an invalid member name is specified or if the record format is incorrect, you must restart IMS with the corrected member name or record format.

If any record in the SSM member of the IMS PROCLIB data set is invalid, a DFS3600 message is issued and processing continues. Valid records allow an external subsystem to be attached. Invalid records in the SSM member of the IMS PROCLIB data set are ignored but can be corrected. Those external subsystems can be attached to the IMS control region using the **/START SUBSYS** command.

Defining the language interface module

In order for an IMS application program to use the language interface module, the application program modules must be bound using the IMS reenterable DL/I language interface. IMS provides the DFSLI macro, which you can use to generate a language interface module. This topic describes the DFSLI macro and its parameters.

In order for an IMS application program to use the language interface module, the application program modules must be bound using the IMS reenterable DL/I language interface. The true attributes must be specified; for example, if a module is reusable only, do not specify "RENT."

Restriction: IMS does not support dynamic calls to the language interface.

To make dynamic calls, provide the RMODE value at bind time so that the language interface is shown below the 16 MB line.

The IMS DL/I language interface is not reenterable. Any IMS application programs that were designed to be reenterable or serially reusable can use external subsystem resources only after being bound with the IMS language interface.

Important: IMS and Db2 for z/OS share a common alias name, DSNHLI, for the language interface module. Keep this in mind when concatenating your libraries to ensure the correct order.

- If you are running an IMS dependent region with an application program using the COBOL dynamic option, the IMS library must be concatenated first.
- If you are running an application program strictly under Db2 for z/OS, be sure the Db2 for z/OS library is concatenated first.

For subsystems other than Db2 for z/OS, IMS provides a language interface module, DFSLI000, which supports the external subsystem interface. DFSLI000 passes a language interface token (LIT) value of SYS1. The installation can use this module or it can define its own language interface if it wants to use a

LIT value other than SYS1. When two or more external subsystems are accessed by the IMS system, the installation must define its own language interface modules because each subsystem has a unique LIT.

IMS provides the DFSLI macro to assist the installation in generating a language interface module. The code necessary to perform the language interface function is generated in the DFSLI macro expansion. The IMS macro library must be supplied when the macro statements are compiled to generate the module. The format of this macro is as follows, where user-supplied values must be substituted for the x's.

```
DFSLIxxx DFSLI TYPE=V2DB,LIT=xxxx  
END
```

where:

DFSLIxxx

Specifies the CSECT name for the module.

Recommendation: Make the CSECT name match the bind name of the language interface module.

For the IMS-supplied language interface module, the value for this parameter is DFSLI000.

TYPE=

Specifies the language interface type to IMS. The only value that you can enter for this parameter is V2DB.

LIT=

Specifies the language interface token that relates this language interface to an external subsystem with their respective specifications in a PROCLIB member entry as the LIT and SSN parameters. The IMS-supplied language interface module DFSLI000 uses a LIT value of SYS1.

Example: When IMS issues an external subsystem request, IMS knows the target subsystem by the LIT used in the request. For example, consider the case of an IMS dependent region accessing two external subsystems ESS1 and ESS2.

- You already have a default language interface module DFSLI000, as specified by the default LIT, SYS1. You now generate a second language interface DFSLI001 with a LIT of SYS2.
- Define two entries in the PROCLIB SSM member. The first entry points to ESS1 with LIT=SYS1. The second entry points to ESS2 with LIT=SYS2.
- Bind IMS application programs accessing ESS1 with the IMS-provided language interface module DFSLI000.
- Bind IMS application programs accessing ESS2 with the language interface module that you have generated, DFSLI001.

Although a region can communicate with two or more external subsystems, an IMS application can access only the external subsystem referred to in the bound language interface. However, you can alter the SSM member to route application requests to a different external subsystem from the subsystem defined in the language interface. Alternatively, you can use the DFSESS entry point in the language interface module.

Specifying trace options

Use the SUBS= parameter on the OPTIONS statement to specify trace options for external subsystems.

If you want to trace the connection and disconnection activities of IMS to the external subsystem, the parameter SUBS= on the OPTIONS statement must be set to ON. Specifying OUT on this parameter causes trace information to be written to the log. If this parameter is omitted, traces can be turned on and off with the /TRACE command.

Specifying Db2 for z/OS groups for IMS online regions

IMS supports the use of Db2 for z/OS data sharing groups.

You can use Db2 for z/OS group names in all dependent regions. The Db2 for z/OS group name is used to call z/OS Name Services. If z/OS returns a positive response to the group inquiry, IMS selects a member of the Db2 for z/OS group that is connected to the IMS control region and connects that Db2 for z/OS to the dependent region under the following condition: The Db2 for z/OS name that was selected was not explicitly defined by another statement with the SSM member.

If that condition is not met, IMS ignores the statement that caused the z/OS Name Services call, and no message is issued.

IMS dependent regions examine the subsystem name that is specified in their SSM member. If the control region is connected to a Db2 for z/OS with that subsystem name, the dependent region connects to it. If the control region is not connected to it, the dependent region assumes that it might be a Db2 for z/OS group attach name. In this case, the dependent region uses this name to access the z/OS Name Services to find any Db2 for z/OS subsystem on the z/OS image that is using this group attach name. It also checks to see if its control region is connected to this Db2 for z/OS and, if so, connects to the specific Db2 for z/OS.

If you are using Db2 for z/OS groups:

- SSM= must be specified when the dependent region starts.
- The name specified on SSN= must be a one- to four-character Db2 for z/OS group name.
- When CRC= is specified and a system is selected from a Db2 for z/OS group, the CRC is changed to that of the control region's corresponding SSM member statement.

IMS BMP, JMP, JBP, MPP, and IFP (dependent regions) support DB2 group attach. The control region does not. For the control region, you must point to the correct subsystem name running on the same LPAR with the IMS.

In the SSM for the control region, you include one of the Db2 for z/OS subsystems in the Db2 for z/OS group that you may use. The SSM for the control region can only specify one member of the group. You cannot specify the Db2 for z/OS group name in the SSM for the control region. In the SSM for the dependent region you can specify the Db2 for z/OS group name and IMS (with help from z/OS) determines if the Db2 for z/OS group can connect or not.

A Db2 for z/OS group name cannot be the same as any Db2 for z/OS subsystem name.

An IMS control region cannot connect to more than one Db2 for z/OS in the same group; however, different IMS control regions on the same z/OS can connect to different instances of Db2 for z/OS in the same group.

A BMP that accesses Db2 for z/OS can be submitted to run on any IMS system in a Parallel Sysplex[®] environment without requiring modification of the SSM parameter or the SSM member of the IMS PROCLIB data set. BMPs that run with different instances of Db2 for z/OS in a data sharing group can use the same SSM member referring to the same Db2 for z/OS. The IMS control region must specify the specific Db2 for z/OS subsystem name or names in its SSM member. IMS control regions cannot use the Db2 for z/OS group attach name.

Examples

For the following two examples, the Db2 for z/OS group name is GRP1 and contains Db2 for z/OS subsystems DB21 and DB22:

Example 1

1. Specify the following in Control Region 1's SSM PROCLIB member:

```
SST=DB2, SSN=DB21, LIT=SYS1, ESMT=DSNMIN10, REO=R, CRC=-
```

2. Specify the following in Dependent Region 1 of Control Region 1's PROCLIB member:

```
SST=DB2,SSN=GRP1,LIT=SYS1,ESMT=DSNMIN10,REO=R,CRC=-
```

An application can run here and get to DB21.

3. Specify the following in Control Region 2's SSM PROCLIB member:

```
SST=DB2,SSN=DB22,LIT=SYS1,ESMT=DSNMIN10,REO=R,CRC=-
```

4. Specify the following in Dependent Region 2 of Control Region 2's PROCLIB member:

```
SST=DB2,SSN=GRP1,LIT=SYS1,ESMT=DSNMIN10,REO=R,CRC=-
```

Example 2

1. Specify the following in Control Region 1's SSM PROCLIB member:

```
SST=DB2,SSN=DB21,LIT=SYS1,ESMT=DSNMIN10,REO=R,CRC=-  
SST=DB2,SSN=DB22,LIT=SYS1,ESMT=DSNMIN10,REO=R,CRC=-
```

2. Specify the following in Dependent Region 1 of Control Region 1's PROCLIB member:

```
SST=DB2,SSN=GRP1,LIT=SYS1,ESMT=DSNMIN10,REO=R,CRC=-
```

In this example, IMS connects to Db2 for z/OS subsystem DB21 or DB22, depending on which Db2 for z/OS is available. The dependent region uses z/OS Name Services to determine if GRP1 is a Db2 for z/OS group, check if any of the systems defined in the Control Region's SSM are within that group, and connect to the first one that is active. If both Db2 for z/OS systems are active, connected to IMS, and part of the same Db2 for z/OS group, then the connection is made to the first one in the list. If GRP1 is not found to be a Db2 for z/OS group using z/OS Name Services, then an attempt is made to connect to GRP1 as a specific Db2 for z/OS.

Specifying Db2 for z/OS for IMS batch regions

The SSM= parameter, instead of the DDITV02 DD statement, can be used in IMS DL/I and DBB batch regions to specify the Db2 for z/OS connection parameters.

The subsystem member in PROCLIB is the same format as for online; however, only a single Db2 for z/OS can be specified. The language interface token (LIT) used is SYS1, and the following additional parameters are passed to Db2 for z/OS by IMS in batch regions:

Connection Name

IMS uses the job name for the batch region as the connection name to provide uniqueness within the z/OS system for Db2 for z/OS.

Plan

IMS uses the application program name as the plan name. The resource translation table (RTT) can be used to translate the program name to the desired plan name if the plan has another name.

Program Name

The application program name can be specified in one of the following ways:

- DSNMTV01 can be specified as the application program name for the batch region. When this method is used, control is given to DSNMTV01. When the Db2 for z/OS environment is established, control is passed to the application program.
- The application program name can be specified for the batch region. When this method is used, the SSM= parameter must be specified on the batch region parameters. Control is given to DSNMTV01 directly to establish the ESS environment. When the Db2 for z/OS environment is established, control is passed to the application program specified in the batch region.

The subsystem member allows a batch region to use Db2 for z/OS without specifying the Db2 for z/OS parameters and application program in the batch region JCL. However, the DDITV02 DD statement can still be used. In fact, the SSM= parameter is overridden if both the DDITV02 DD statement is used and DSNMTV01 is the batch application program name.

The DDOTV02 DD statement must be used for messages and diagnostic information regardless of how the Db2 for z/OS connection parameters are specified.

Preparing Db2 for z/OS for use with IMS

You must perform several tasks to prepare Db2 for z/OS for use with IMS.

Providing appropriate tables in your ESS

It is the responsibility of the Db2 for z/OS user to provide the external subsystem module table, and optionally, the resource translation table in the Db2 for z/OS subsystem.

It is also the user's responsibility to make the names of these tables known to the person who is responsible for defining the IMS PROCLIB data set member entries. The person defining the IMS PROCLIB data set member entries includes the names of these tables as values for the parameters ESMT and RTT, respectively.

Placing Db2 for z/OS modules and tables in the appropriate library

IMS loads the modules and tables specified in the external subsystem module table from the Db2 for z/OS libraries when the SSM EXEC parameter is specified in an IMS region. To ensure that this process is successful, you must make the Db2 for z/OS libraries, which must be APF-authorized, available to IMS.

For this purpose, you can either add the Db2 for z/OS libraries to the JOBLIB/STEPLIB/LINKLIST concatenation or create a DFSESL DD statement for this purpose. IMS does not automatically generate a DFSESL DD statement.

If the JOBLIB/STEPLIB/LINKLIST concatenation is not authorized, you must use the DFSESL DD statement. For online IMS regions, the subsystem library or libraries must be concatenated after the library containing the IMS modules (typically IMS.SDFSRESL). When multiple subsystems are connected, additional subsystem data sets can be concatenated.

Note: The DFSESL DD statement is used by IMS to load specific modules or tables and is not part of a general library search.

Example:

```
//DFSESL DD DISP=SHR, DSN=IMS.SDFSRESL
//      DD DISP=SHR, DSN=DSNxxx.DSNLOAD
//      DD DISP=SHR, DSN=DSNyyy.DSNLOAD
```

IMS.SDFSRESL is first, followed by the subsystem libraries.

For IMS batch regions, the DFSESL DD statement is not used. The Db2 for z/OS libraries must be in both the JOBLIB/STEPLIB/LINKLIST concatenation and the DFSRESLB DD statement for authorized modules.

If you use the COBOL II dynamic option, the Db2 for z/OS libraries must be added to the JOBLIB or STEPLIB regardless of authorization. The DD statement that specifies IMS.SDFSRESL must precede the reference to DSNxxx.DSNLOAD in the JOBLIB or STEPLIB. If the JOBLIB or STEPLIB is not authorized, you must also use a DFSESL DD statement.

Configuring JMP and JBP regions for Db2 for z/OS data access

JMP and JBP applications can access Db2 for z/OS databases. Before your JMP and JBP applications can access Db2 for z/OS databases, you must configure the JMP and JBP region to use either the Db2 Resource Recovery Services attachment facility (RRSAF) or the external subsystem attach facility (ESAF) to attach Db2 for z/OS to IMS.

This topic describes how to set up a JMP or JBP region to access Db2 for z/OS databases. It does not describe how to set up Db2 for z/OS for access from IMS. For information about setting up Db2 for z/OS for Java application access, see *DB2 for z/OS Application Programming Guide and Reference for Java*. You must create a Db2 for z/OS plan for each PSB (typically each Java application) that is used to access Db2 for z/OS.

For JMP or JBP applications to have Db2 for z/OS access, you must either attach Db2 for z/OS to IMS using the Db2 Resource Recovery Services attachment facility (RRSAF) or use the external subsystem attach facility (ESAF). The default for JMP or JBP regions is to use RRSAF.

Db2 for z/OS provides different JDBC drivers:

- JDBC/SQLJ driver for Db2 for z/OS with JDBC 2.0 support (called the Db2 for z/OS JDBC/SQLJ 2.0 driver), which allows access to Db2 for z/OS databases only when IMS is on the same z/OS image as Db2 for z/OS. This is a type 2 JDBC driver.
- JDBC/SQLJ driver for Db2 for z/OS with JDBC 1.2 support (called the Db2 for z/OS JDBC/SQLJ 1.2 driver), which allows access to Db2 for z/OS databases only when IMS is on the same z/OS image as Db2 for z/OS. This is a type 2 JDBC driver.
- Db2 for z/OS Universal JDBC driver, which allows access to Db2 for z/OS databases from IMS systems that are on different z/OS images from Db2 for z/OS when you use the IMS Universal drivers type 4 connectivity. You can also use the type 2 implementation of this driver for access to Db2 for z/OS databases when IMS is on the same z/OS image as Db2 for z/OS.

All these drivers are referred to in this topic as Db2 for z/OS JDBC drivers.

Identifying Db2 for z/OS JDBC drivers

For type 2 JDBC drivers, you must use the default connection URL in the application program. For example, `jdbc:db2os390:` or `db2:default:connection`.

For type 4 JDBC drivers, you can use a specific connection URL in the application program.

With RRSAF, the dependent region builds an attachment thread to Db2 for z/OS using z/OS Resource Recovery Services (RRS). RRS coordinates the commits of the updates that the application program makes to both IMS and Db2 for z/OS resources. IMS is a participant, not the coordinator, of these updates and commits.

Attaching a Db2 for z/OS subsystem to IMS using RRSAF

To attach a Db2 for z/OS subsystem to IMS using RRSAF so that IMS JMP and JBP regions can access Db2 for z/OS databases, follow this procedure.

Procedure

1. Create an IMS PROCLIB data set member for information about the Db2 for z/OS subsystem.
The member name must follow the same naming conventions you follow when you attach Db2 for z/OS with ESAF.
2. In the IMS PROCLIB data set member, define the following three parameters for the Db2 for z/OS subsystem that JMP and JBP applications need access to:

```
SST=DB2,SSN=db2name,COORD=RRS
```

You can provide two different definitions for the same Db2 for z/OS system

- An ESAF definition for non-Java regions
 - An RRSAF definition for Java regions
3. Add the followings paths to the Java class path. If you use the `//STDENV DD` statement, add the paths to the shell script that specifies the JVM settings. Otherwise, add the paths to the class path of the DFSJVMMS member, which is provided by IMS in a sample library.
 - Path to the .zip file of the Db2 for z/OS JDBC driver
 - Path to the .zip file and .zip file name of the Db2 for z/OS JDBC driver

For example:

```
-Djava.class.path=>
/usr/lpp/db2/db2710/classes: >
/usr/lpp/db2/db2710/classes/db2j2classes.zip
```

4. Add the path to the SO file of the Db2 for z/OS JDBC driver to the LIBPATH= environment variable. If you use the //STDENV DD statement, add the path to the LIBPATH= parameter in the shell script that specifies the JVM settings. Otherwise, add the path in the DFSJVMEV member, which is provided by IMS in a sample library.

For example:

```
LIBPATH=/usr/lpp/db2/db2710/lib
```

5. Add the following parameters to the IMS control region EXEC statement:

```
SSM=nameRRS=Y
```

6. In the DFSJMP or DFSJBP procedure of the region that has access to Db2 for z/OS, add the DFSDB2AF DD statement to point to the Db2 for z/OS libraries, which must be APF-authorized.

Results

Related Reading: For details about the IMS PROCLIB data set member and procedure parameters, see Chapter 20, “Members of the IMS PROCLIB data set,” on page 665. For information about the Db2 for z/OS JDBC drivers, see *DB2 for z/OS Application Programming Guide and Reference for Java*.

Related reference

[“DFSJVMEV \(JVM environment settings member\)” on page 841](#)

The DFSJVMEV member of the IMS PROCLIB data set is a sample member that is supplied in the IMS sample library (the SDFSSMPL data set). Use this member to specify the Java virtual machine (JVM) environment settings and to capture JVM usage statistics.

[“DFSJVMMS member of the IMS PROCLIB data set” on page 844](#)

You can use the DFSJVMMS member of the IMS PROCLIB data set to specify JVM options for the standalone JVM for JBP regions.

Chapter 15. Setting up IMS for diagnostics

IMS can process large amounts of work efficiently; however, IMS can experience problems that need to be diagnosed and corrected. For these types of problems, IMS displays symptoms that can help you with your diagnosis, but, in order to obtain that information, you need to set up your system correctly.

Setting the size of the z/OS trace tables

When you set up your IMS system for diagnostics, you need to consider your settings for z/OS trace tables as well.

z/OS system trace table

The z/OS system trace table is valuable for a large variety of problem types. The system trace table is page-fixed storage, and the default size is only 64 KB. You must ensure that there are enough real page frames for this specification.

Set z/OS system trace table size to 999 KB by issuing the z/OS command `TRACE ST,999K` in the z/OS `COMMNDxx` member of the `SYS1.PARMLIB` data set.

See *z/OS MVS System Commands* for more information.

z/OS master trace table

The master trace table maintains the most recently issued operator messages. It provides a view of external events at the time of failure. Ensure that the master trace table is large enough to span most error time frames. The default size is only 24 KB, which allows approximately 336 messages. A 500 KB specification allows approximately 7000 messages.

The master trace uses Subpool 229 Key 0 High Private Pageable Storage of the master scheduler address space.

Set the z/OS master trace table size to 500 KB by specifying the command `TRACE MT,500K` in the `SCHEDxx` member of the `SYS1.PARMLIB` data set.

See *z/OS MVS Diagnosis: Tools and Service Aids*, *z/OS MVS Initialization and Tuning Reference*, and *z/OS MVS System Commands* for complete details.

Common Storage Tracker

When you set up your IMS system for diagnostics, you should also start the z/OS common storage tracking function.

About this task

To track ownership of the Common Service Area (CSA) and the Extended Common Service Area (ECSA), turn on the z/OS common storage tracking function.

- Use the `DIAGxx` member of the `SYS1.PARMLIB` data set to contain the request. Specify `DIAG=xx` in the IPL system parameters or use the `SET DIAG=xx` operator command.
 - For example, in the `DIAGxx` member:

```
VSM TRACK CSA(ON)
```

See *z/OS MVS Diagnosis: Tools and Service Aids*, *z/OS MVS Initialization and Tuning Reference*, and *z/OS MVS System Commands* for complete details.

- Advantages:

- Supervisor call (SVC) dumps (or RMF reports) provide CSA/ECSA ownership information with job name, time, and requesting module information.
- Considerations:
 - Performance can be degraded and extended system queue area (ESQA) is used proportionally to the CSA workload.

CHNGDUMP MAXSPACE

When you set up your IMS system for diagnostics, you should ensure that the space defined for the internal supervisor call (SVC) dump is adequate, and if not, use CHNGDUMP MAXSPACE to modify it.

About this task

Ensure that an adequate CHNGDUMP MAXSPACE value is specified to hold the internal supervisor call (SVC) dump.

- Use the COMMNDxx member of the SYS1.PARMLIB data set to issue the appropriate CHNGDUMP command during IPL.
 - For example: `CD SET,SDUMP,MAXSPACE=1000M`
 - Default size is 500 MB
 - 2500 MB or larger is standard for large multi-address space SVC Dumps.
 - One way to estimate the amount of storage needed for the SVC dump is to calculate the total amount of global storage in use by adding the amount of storage used by all the regions (at peak usage) as viewed by online monitor programs.

See *z/OS MVS Diagnosis: Tools and Service Aids*, *z/OS MVS Initialization and Tuning Reference*, and *z/OS MVS System Commands* for complete details.

- Advantages:
 - Higher likelihood that SVC dumps are captured in their entirety without worry of partial dump.
- Considerations:
 - Ensure that local page data sets are large enough to contain their normal peak load, plus additional SVC dumps.

Automatic dump data set allocation

When you set up your IMS system for diagnostics, ensure that the automatic dump data set has been allocated by using the COMMNDxx member of the SYS1.PARMLIB data set.

About this task

Ensure that automatic dump data set allocation is in place.

- Use the COMMNDxx member of the SYS1.PARMLIB data set to issue the appropriate DUMPDS commands to set up dump data set allocations:
 - `DUMPDS NAME=, DUMPDS ADD, and DUMPDS ALLOC=ACTIVE.`
 - See *z/OS MVS Diagnosis: Tools and Service Aids* and *z/OS MVS System Commands* for complete details.
- Advantages:
 - SVC dumps are allocated to the correct size without worry of partial dump.
- Considerations:
 - Ensure that the assigned storage class has enough space for the SVC dump storage requirements.

Because system dumps for IMS Version 11 and later generally contain more address spaces than do dumps for previous IMS versions, you might need to increase the amount of virtual storage that an SVC dump can use to capture volatile virtual storage data, summary dump data, and component-specific data before writing the dump to DASD.

Diagnostic setup recommendations for IMS

When you set up your IMS system for diagnostics, consider not only the IMS diagnostic settings, but also the z/OS systems settings that impact IMS diagnostics.

FMTO option

Specify the FMTO=D IMS control region EXEC parameter value.

- This parameter produces a system dump (SDUMP) for terminating and non-terminating errors, specifically, Db2 for z/OS and dynamic-allocation abends. Non-terminating errors include:
 - IMS dynamic allocation failures.
 - Some external subsystem attach facility (ESAF) failures.

A SYSMDUMP, SYSABEND, or SYSUDUMP is produced only if SDUMP fails.

Note: Make sure that you use FMTO=D so that you get a system dump if IMS abends. Do not rely on SYSMDUMP, SYSABEND, or SYSUDUMP as your primary source of diagnostic information. These dumps only dump a single address space, and sometimes they do not provide adequate storage for complete diagnosis of abends.

SYSMDUMP DD

- Specify the SYSMDUMP DD statement in JCL of the following IMS regions:
 - IMS CTL (control)
 - IMS DLI (data language interface)/SAS (separate address space)
 - IMS DBRC (Database Recovery Control)
- The SYSMDUMP specification is used by IMS if SDUMP processing fails.
- You should specify the following dump options in the SYS1.PARMLIB(IEADMR00) member to ensure that adequate areas of z/OS storage are dumped to diagnose the problem under most circumstances:

```
SDATA=(CSA,LSQA,RGN,SQA,SUM,SWA,TRT)
```

- Specify the SYSUDUMP DD statement in JCL of IMS Dependent Regions. The SYSUDUMP specification is used by IMS dependent regions for failure events.
- You should specify the following dump options in the z/OS SYS1.PARMLIB(IEADMP00) member to ensure that adequate areas of z/OS storage are dumped:

```
SDATA=(CB,ERR,SUM) PDATA=(JPA,LPA,PSW,REGS,SA,SPLS)
```

Table traces

For type-1 table traces:

- Set the IMS Dispatcher, Scheduler, DL/I, and Lock traces on. Perform one of the following:
 - The DL/I and LOCK traces are set on by default when IMS initializes.
 - To set the DISP and SCHED traces on, specify the following options in the DFSVSMxx member of the IMS.PROCLIB data set:

```
DISP=ON, SCHED=ON
```

- Use the IMS /TRA SET ON TABLE *nnnn* command, where *nnnn* is alternately = DISP, SCHD, DLI, or LOCK.
- You should turn on the LATCH trace only in non-production environments.
The LATCH trace can carry a large amount of overhead, so it is not recommended as a default in a production environment.

Recommendation: Use the IMS LATCH trace for all test systems. Your system might experience measurable performance reduction if the LATCH trace is active in production. To set the LATCH trace on, specify LATC=ON for the LATCH trace in the DFSVSMxx member of the IMS.PROCLIB data set.

External trace environment

- IMS external tracing allows for type-1 IMS trace table output to be placed on IMS trace data sets rather than on the IMS OLDS (online data set) when:
 - The DISP=OUT option is used in the DFSVSMxx member of the IMS.PROCLIB data set.
 - The LOG option is used with the IMS TRACE commands.
- Using external trace can increase IMS system throughput.
- External trace data sets are allocated in the following order:
 1. DASD JCL: DFSTRA01 and DFSTRA02 DD statement.
 2. DASD MDA: DFSTRA01 and DFSTRA02 Dynamic Allocation Members.
 3. TAPE MDA: DFSTRA0T Dynamic Allocation Member.
 4. IMS OLDS: If none of the above are found.

For more information, see [“Setting up the external trace environment” on page 343](#).

Setting the z/OS system trace table size

The z/OS system trace is useful for many types of z/OS problems. At times, it is the only means of reconstructing a problem. The larger you can specify the size of the trace table, the better the chance of diagnosing some of the more intricate problems encountered while running IMS. Specify the z/OS command TRACE ST,999K in the z/OS COMMNDxx member of the SYS1.PARMLIB data set so that the trace table size is in effect during IPL. If you do not specify a trace table size, the default size is 64 KB. If your installation has a limited number of real page frames, remember that the system trace table is page fixed. If you specify the dump option SDATA=(TRT), the dump size increases.

Setting the z/OS master trace table size

The z/OS master trace table contains a buffer of messages from the z/OS master console. These messages are saved in the SDUMP data set and can be viewed using IPCS to aid in problem diagnosis. Specify the z/OS command TRACE MT,100K in the z/OS SCHEDxx member of the SYS1.PARMLIB data set so that the trace table size is in effect during IPL. If you do not specify a trace table size, the default size is 64 KB.

CQS trace setup recommendations

There are specific recommendations for optimally setting up your CQS (Common Queue Server) system.

Trace environment - conservative

You can specify the CQS execution parameter `BPECFG=nnnnnnnn` in a way that is optimal for conservative trace environments.

Specify the following trace entries within the BPE configuration parameter member of the IMS PROCLIB data set:

```
--DEFINITIONS FOR BPE SYSTEM TRACES
TRCLEV=(AWE,LOW,BPE) /* AWE SERVER TRACE *
TRCLEV=(CBS,LOW,BPE) /* CONTROL BLK SRVCS TRACE *
TRCLEV=(DISP,LOW,BPE) /* DISPATCHER TRACE *
TRCLEV=(LATC,LOW,BPE) /* LATCH TRACE *
TRCLEV=(SSRV,LOW,BPE) /* GEN SYS SERVICES TRACE *
TRCLEV=(STG,LOW,BPE) /* STORAGE TRACE *
TRCLEV=(USRX,LOW,BPE) /* USER EXIT TRACE *
--DEFINITIONS FOR CQS TRACES
TRCLEV=(CQS,LOW,CQS) /* CQS GENERAL TRACE */
TRCLEV=(INTF,LOW,CQS) /* CQS INTERFACE TRACE */
TRCLEV=(OFLW,LOW,CQS) /* CQS STRUCTURE OVERFLOW TRACE */
TRCLEV=(SEVT,LOW,CQS) /* CQS STRUCTURE EVENTS TRACE */
TRCLEV=(STR,LOW,CQS) /* CQS CLIENT ACTIVITIES TRACE */
```

Related reference

[“BPE configuration parameter member of the IMS PROCLIB data set” on page 665](#)

Use the BPE configuration parameter member of the IMS PROCLIB data set to define BPE execution environment settings such as tracing, language, and statistics time interval settings for an address space that is being started.

Trace environment - more aggressive

You can specify the CQS execution parameter `BPECFG=nnnnnnnn` in a way that is optimal for more aggressive trace environments.

Specify the following trace entries within the BPE configuration parameter member of the IMS PROCLIB data set:

```
--DEFINITIONS FOR BPE SYSTEM TRACES
TRCLEV=(AWE,HIGH,BPE,PAGES=24)/*AWE SERVER TRACE */
TRCLEV=(CBS,MEDIUM,BPE,PAGES=12)/*CONTROL BLK SRVCS TRACE */
TRCLEV=(DISP,HIGH,BPE,PAGES=36)/*DISPATCHER TRACE */
TRCLEV=(LATC,HIGH,BPE,PAGES=72)/*LATCH TRACE */
TRCLEV=(SSRV,HIGH,BPE,PAGES=6)/*GEN SYS SERVICES TRACE */
TRCLEV=(STG,LOW,BPE,PAGES=12)/*STORAGE TRACE */
TRCLEV=(USRX,MEDIUM,BPE,PAGES=12)/*USER EXIT TRACE */
--DEFINITIONS FOR CQS TRACES */
TRCLEV=(CQS,LOW,CQS) /* CQS GENERAL TRACE */
TRCLEV=(INTF,LOW,CQS) /* CQS INTERFACE TRACE */
TRCLEV=(OFLW,LOW,CQS) /* CQS STRUCTURE OVERFLOW TRACE */
TRCLEV=(SEVT,LOW,CQS) /* CQS STRUCTURE EVENTS TRACE */
TRCLEV=(STR,LOW,CQS) /* CQS CLIENT ACTIVITIES TRACE */
```

Related reference

[“BPE configuration parameter member of the IMS PROCLIB data set” on page 665](#)

Use the BPE configuration parameter member of the IMS PROCLIB data set to define BPE execution environment settings such as tracing, language, and statistics time interval settings for an address space that is being started.

Installing the IMS Dump Formatter

You can install the IMS Dump Formatter by updating several DD concatenations.

About this task

Prerequisite: Before you begin installing the IMS Dump Formatter, make sure that you have IPCS already functioning with ISPF/PDF.

Perform the following procedure:

Procedure

1. Install the IMS Dump Formatter by updating the DD concatenations listed in [Table 45 on page 342](#):

Table 45. DD concatenations to update

DDNAME	Data Set to Be Added	Contents of Data Set
SYSPROC	IMS.SDFSCLST	CLISTs
	IMS.SDFSEXEC	REXX EXEC
ISPMLIB	IMS.SDFSMLIB	Messages
ISPPLIB	IMS.SDFSPLIB	Panels
ISPTLIB	IMS.SDFSTLIB	Tables
IPCSPARM	IMS.SDFSMAC	All IMS macros
		Note: DFSIPCSP is the only member that is used from this data set.
TASKLIB	IMS.SDFSRESL	Formatting modules
		Note: The TASKLIB concatenation is specified as part of the IPCS command invocation.
SYS1.PARMLIB (for IPCSPR00 member)	MACLIB DD and IMS.SDFSMAC	

2. Add the Offline Dump Formatting module name to the Print Dump Exit Control Table in the SYS1.PARMLIB member BLSCECTX.

The IMS Offline Dump Formatting module should already be defined to z/OS as part of z/OS preconditioning for IMS. If the definition is missing, update the BLSCECTX member of SYS1.PARMLIB with the following:

```
EXIT EP(DFSOFMD0) VERB(IMSDUMP) ABSTRACT('IMS analysis')
```

Results

For more information about BLSCECT (the Formatting exit routines for dump and trace analysis for IPCS), see *z/OS MVS Initialization and Tuning Reference*.

The IMS IVP job IV_D202T also provides an example.

Making IMS.SDFSRESL available

After updating the DD concatenation for IMS.SDFSRESL, you need to make it available.

About this task

To make IMS.SDFSRESL available, use one of the following methods:

- Add the IMS.SDFSRESL data set to the ISPF ISPLLIB
- Add the IMS.SDFSRESL data set to STEPLIB in the TSO logon procedure
- Use TSOLIB from TSO READY to establish IMS.SDFSRESL in the search list:

```
TSOLIB ACTIVATE DATASET('IMS.SDFSRESL')
```

If you do not want to add the entire IMS.SDFSRESL data set to the concatenation, you can concatenate a data set that contains both DFSABND0 and DFSOFMD0 load modules from the highest IMS version level with the alias modules from the IMS.SDFSRESL for lower-level IMS versions that you want to format.

The following example shows how to concatenate DFSABND0 and DFSOFMD0 from IMS Version 12 and provide format support for IMS Version 11:

```
DFSABND0 DFSAB121 DFSAB111  
DFSOFMD0  
DFSOF121  
DFSOF111
```

For more information, see *z/OS TSO/E Command Reference*.

Setting up the external trace environment

You can request external tracing by starting traces with the OUT option, or by entering the /TRACE SET ON TABLE xxxxx OPTION LOG command to start the trace with the LOG option.

You can start certain traces at IMS initialization with these methods:

- For online systems, specify the appropriate trace keywords on the OPTIONS statement in the DFSVSMxx member of the IMS PROCLIB data set.
- For a batch environment, specify the appropriate trace keywords on the DFSVSAMP DD statement.

You can also turn tracing off or on by using the /TRACE command.

See [“DFSVSMxx member of the IMS PROCLIB data set” on page 857](#) for more information.

Controlling the volume of traces

Control the volume of the traces using the VOLUME parameter on the /TRACE TABLE command.

The parameter can be set to high, medium, low, or error, where high generates the largest volume of trace entries, and error generates the smallest volume of trace entries.

For details about the /TRACE command parameters, see *IMS Version 15.4 Commands, Volume 2: IMS Commands N-V*. For details about the OPTIONS statement in the DFSVSAMP or DFSVSMxx data set, see [“DFSVSMxx member of the IMS PROCLIB data set” on page 857](#).

Recommendation: Ensure that your IMS environment is running with the following traces on at all times:

- Dispatcher
- DL/I
- Lock
- Scheduler

None of these traces causes a noticeable performance impact, and each of these can be helpful to you in diagnosing various problems that might occur in your environment.

Note: The DL/I and LOCK traces are set on as a default at IMS initialization.

Activating Fast Path traces

In a Database Control (DBCTL) environment, you can trace DL/I and Fast Path activity. You turn on the DL/I trace in the same way as in a DB/DC environment.

The trace records for coordinator controller (CCTL) threads contain the recovery token that can help you correlate CCTL tasks with DBCTL threads.

Activate Fast Path tracing in one of the following ways:

- The DBCTL operator can enter the `/TRACE SET ON TABLE FAST` command. This is the same way you activate the trace in a DB/DC environment. In both DBCTL and DB/DC environments, you must also specify the `FPTRACE DD` statement in the `IMSFP` procedure, which is described in [“IMSFP procedure” on page 656](#).
- The CCTL decides which transactions to trace and directs DBCTL to activate the trace for those transactions. After the transaction completes, the trace output file is closed and sent to the `SYSOUT` data set, class A. However, when certain transactions fail in Fast Path processing and the trace is not already active, the database resource adapter (DRA) recommends to the CCTL that Fast Path tracing be activated. The failures for which tracing is recommended are based on the list that IMS uses for Fast Path Transaction Retry. The CCTL can then direct DBCTL (through the DRA) to activate Fast Path tracing the next time that transaction is scheduled.

Writing trace tables externally

You can write the in-memory trace tables to an external device, tape data set, or to the OLDS (online log data set).

When the IMS MTO starts IMS trace table traces with the `LOG` option, the following selection order determines where the external traces are written.

DASD JCL

DD statements are checked to verify that `DFSTRA01` or `DFSTRA02` are present. If either or both are present, the JCL specified DASD external trace data sets are used if possible.

DASD MDA

An attempt is made to dynamically allocate and open `DFSTRA01` and `DFSTRA02` by using dynamic allocation members. If either or both dynamic allocations succeed, the DASD external trace data sets are used if possible.

TAPE MDA

An attempt is made to dynamically allocate and open member `DFSTRA0T`. If the dynamic allocation succeeds, the external trace tapes are used if possible.

IMS log data set

The IMS log data set is used for external trace. Because of the performance effects of logging trace data to the online log data set, the operator is asked to approve tracing to the online log data set when external trace data sets cannot be used.

To print the `X'67FA'` records, use the File Select and Formatting Print utility (`DFSERA10`), and specify exit `DFSERA60` to format the trace entries.

`DFSTRA01` and `DFSTRA02` are the external trace data sets used by the IMS online systems. The trace data sets are used when the trace table `OUT` parameter is used in the `DFSVSMxx` options statement, or when the `/TRACE SET ON TABLE nnn OPTION LOG` command is used. The trace data sets are used in a wrap-around fashion. For example, when `DFSTRA01` fills, `DFSTRA02` is used; when `DFSTRA02` fills, `DFSTRA01` is used.

Recommendation: You must remember to offload the trace data set before it is reused. Use the `IEBGENER` utility to offload the data set.

Related tasks

[Collecting data about specific problems \(Diagnosis\)](#)

Creating output data sets with correct attributes

When you specify particular attributes, you can use the DFSTRA01, DFSTRA02, and DFSTRA0T data sets to hold your trace data.

Create the DFSTRA01 and DFSTRA02 trace data sets with the following attributes, in order for you to use them to hold your trace data:

DSORG

PS (Physical Sequential)

RECFM

VB

LRECL

4016

BLKSIZE

A formula of: $(LRECL * N) + 4$. The block size must be a multiple of the LRECL (4016), with the additional 4 bytes for the block descriptor word.

Recommendation: Use a BLKSIZE of 20,084, which is five logical records in length (4016 bytes, multiplied by 5), plus the block descriptor word (4 bytes). The BLKSIZE of 20,084 is recommended for current DASD because it is equal to one-half track.

Recommendation: Allocate these data sets as a single extent, meaning contiguous tracks. Do not specify secondary allocation.

In order to use a tape to hold the external trace data set, you must use the DFSTRA0T data set. DFSTRA0T must be dynamically allocated with the following attributes:

DSORG

PS (Physical Sequential)

RECFM

VB

LRECL

4016

BLKSIZE

A formula of: $(LRECL * N) + 4$. The block size must be a multiple of the LRECL (4016), with the additional 4 bytes for the block descriptor word.

In order to dynamically create these data sets, use the following JCL example.

```
/STEP EXEC IMSDALOC
//SYSIN DD *
DFSMDA TYPE=INITIAL
DFSMDA TYPE=TRACE,DDNAME=DFSTRA01,DSNAME=IMS41.DFSTRA01
DFSMDA TYPE=TRACE,DDNAME=DFSTRA02,DSNAME=IMS41.DFSTRA02
DFSMDA TYPE=TRACE,DDNAME=DFSTRAT2,DSNAME=IMS41.DFSTRA0T
DFSMDA TYPE=FINAL
END
```

Setting up tracing for BPE-managed address spaces

The member of the IMS PROCLIB data set that you specify using the BPECFG= parameter in the execution parameters for the BPE-managed address spaces defines configuration parameters to the Base Primitive Environment (BPE), including trace levels.

About this task

Perform the following procedure to set up tracing for BPE-managed address spaces:

Procedure

1. To set the trace level for BPE-managed trace tables in the CQS, IMS Connect, ODBM, OM, RM, RS, SCI, and BPE-based DBRC address spaces, use the TRCLEV= statement in the BPE configuration parameter member of the IMS PROCLIB data set.

The TRCLEV= parameter is used in the BPE configuration member of the IMS PROCLIB data set to specify the trace level for a trace table and, optionally, the number of pages of storage allocated for the trace table. You can specify one TRCLEV= parameter for each trace table type that BPE, CQS (common queue server), ODBM (Open Database Manager), OM (Operations Manager), RM (Resource Manager), Repository Server (RS), SCI (Structured Call Interface), IMS Connect, and BPE-based Database Recovery Control (DBRC) support.

Trace tables are written to internal memory in the BPE address space unless you enable BPE external tracing for the trace table.

2. Enable BPE external tracing (writing trace data to an external data set as well as to memory).

You must complete both of the following tasks:

- a) Define, or modify, the BPE configuration parameter member (BPECFG) of the IMS PROCLIB data set to include the external trace parameters:
 - i) Add the EXTTRACE statement to the BPE configuration parameter member (BPECFG) of the IMS PROCLIB data set. This statement defines the external trace data set to IMS.
 - ii) **Optional:** update the TRCLEV statement for each trace table that is to be externalized by adding the EXTERNAL=YES keyword in the BPE configuration parameter member (BPECFG) of the IMS PROCLIB data set. This keyword causes the specified tables to be written to the external trace data set from the beginning of the address space. The default is EXTERNAL=NO. BPE trace tables can also be set to be written to the external trace data sets dynamically, by issuing the BPE UPDATE TRACETABLE command with the EXTERNAL(YES) parameter after the address space has started.
- b) Define a generation data group (GDG) for the external trace data set.

Use the IDCAMS DEFINE GENERATIONDATAGROUP command to define the GDG. The value that you specify for the NAME keyword in this command must match the data set name in the GDGDEF parameter of the EXTTRACE statement of the BPE configuration parameter member (BPECFG) of the IMS PROCLIB data set. If the data control block (DCB) characteristics of a GDG data set are not defined anywhere on the system, you must also define a prototype data set with the appropriate DCB characteristics on the volume containing the system catalog. Here is an example of how that JCL would look:

```
//PROTOTYP JOB ...
//STEP1 EXEC PGM=IEFBR14
//BLDDSCB DD DSN=BPEEXTRC.GDG01,
// DISP=(NEW,KEEP),
// UNIT=SYSDA,
// VOL=SER=PAGE01, <=System catalog volume
// SPACE=(TRK,(0)),
// DCB=(DSORG=PS,RECFM=VB,BLKSIZE=24580,LRECL=24576)
```

You can issue the IDCAMS DEFINE GENERATIONDATAGROUP command from an IDCAMS job, a TSO session, or a TSO command batch job, as shown in the following three examples, respectively.

```
//DEFGDG JOB ...
//STEP1 EXEC PGM=IDCAMS
//SYSPRINT DD SYSOUT=A
//SYSIN DD *
DEFINE GENERATIONDATAGROUP -
(NAME(BPEEXTRC.GDG01) -
NOEMPTY -
SCRATCH -
LIMIT(255))
```

```
DEFINE GENERATIONDATAGROUP (NAME(BPEEXTRC.GDG01) NOEMPTY SCRATCH LIMIT(255))
```

```
//DEFGDG      JOB      ...
//STEP1      EXEC    PGM=IKJEFT01
//SYSTSPRINT DD      SYSOUT=A
//SYSTSIN    DD      *
DEFINE GENERATIONDATAGROUP (NAME(ICFUCAT1.GDG01) NOEMPTY SCRATCH LIMIT(255))
```

Results

For more information about the DEFINE GENERATIONDATAGROUP command, see *z/OS DFSMS Access Method Services for Catalogs*.

Related concepts

“Overview of the IMSRSC repository” on page 37

A repository is a generalized data storage facility that can be used to store any type of information. The IMS resource definition (IMSRSC) repository is a set of VSAM key sequenced data sets (KSDSs) used for storing information. The IMSRSC repository is a repository to store resource (and descriptor) definitions for IMS databases, transactions, programs, and routing codes. This repository is an alternative to the resource definition data set (RDDS) that is used with the dynamic resource definition (DRD) function.

Setting up type-2 trace tables

Set up type-2 trace tables in the DFSDFxxx member by using the TRCLEV statement with the table names, volume level, and size to help collect diagnostic data.

Procedure

Take the following steps to set up type-2 trace tables:

1. Add the TRCLEV statement to the DIAGNOSTICS_STATISTICS section of the DFSDFxxx PROCLIB member. Specify the table name, the volume level, and the number of pages that are allocated for the table.

The following example demonstrates how the TRCE and DDL tables are set up in the DFSDFXXX member.

```
/* **** */
/* DFSDFXXX MEMBER */
/* DIAGNOSTIC SECTION */
/* **** */
<SECTION=DIAGNOSTICS_STATISTICS>

TRCLEV=(NAME=TRCE, /* Type-2 trace services trace table */
        LEVEL=LOW) /* Low volume */

TRCLEV=(NAME=DDL, /* Type-2 DDL trace table */
        LEVEL=HIGH, /* High volume */
        PAGES=30) /* Allocate 30 pages for tables */
```

2. Activate the type-2 trace tables.

The type-2 trace tables are activated when IMS starts up. If IMS is already active before the TRCLEV statement is added, use the **UPDATE TRACE** command to activate the trace tables.

All type-2 trace tables, TRCE, ERR, DDL, and USRX, can be activated for the following environment:

- Batch
- DB/DC
- DBCTL
- DCCTL
- FDBR
- XRF alternate

If you attempt to activate a trace in an environment that does not support the type of traces, IMS ignores the request.

Results

To verify whether type-2 trace tables are activated, issue the **QUERY TRACE** command.

Related reference

[“DIAGNOSTICS_STATISTICS section of the DFSDFxxx member” on page 777](#)

The DIAGNOSTICS_STATISTICS section of the DFSDFxxx member specifies options for the IMS Abend Search and Notification procedure (DFSASNO) and for obtaining database and transaction statistics. The section is defined by the header <SECTION=DIAGNOSTICS_STATISTICS>. The DIAGNOSTICS_STATISTICS section is valid in DB/DC, DBCTL, and DCCTL environments.

[UPDATE TRACE command \(Commands\)](#)

[QUERY TRACE command \(Commands\)](#)

Setting up the IMS abend search and notification function

Use the IMS abend search and notification function to notify personnel of abnormal termination (abend) and to research and retrieve links to information about abends.

About this task

The abend search and notification function enables IMS to send an email or text message to a predesignated recipient in order to:

- Notify the correct people about an abnormal termination (abend)
- Provide additional information about the abend

The abend search and notification function can also be used to research and retrieve links to information about abends which include IMS product documentation, technical notes in an IBM technical support database and information in the preventive service planning (PSP) database.

Restriction: The abend search and notification function triggers only for MPP or BMP dependent region abends that involve IMS system processing. This function cannot be used to notify IMS application abends.

To set up and enable the IMS abend search and notification function:

Procedure

1. Allocate and authorize the following two data sets:

- A runtime data set that contains the information from the choices made during the setup process when working with the IMS abend search and notification system setup panel. The name of this runtime data set is included in all the JCL jobs that are generated by the IMS abend search and notification function. The DCB for runtime data set is RECFM=FB,LRECL=80.

Users of the IMS abend search and notification system setup panel need update access to the runtime data set. All other users of the IMS abend search and notification function need read-only access. Examples of such users are:

- Started tasks that initiate abend-event driven invocation of the function
- Users of the IMS abend search and notification on-demand panels
- The user ID associated with the IMS control region
- A skeleton data set that contains the name of the IMS abend search and notification procedure. Access authorizations to the skeleton data set are the same as the authorizations needed for the runtime data set. The DCB for skeleton data set is RECFM=FB,LRECL=80.
- A skeleton data set that contains the following members:
 - - DFSSPRCI, which specifies the name of the IMS abend search and notification procedure.
 - - DFSSPCLI, which specifies a JCLLIB statement that points to where the procedure resides.

The DCB for the skeleton data set is RECFM=FB,LRECL=80.

The skeleton data set must be concatenated to the ISPSLIB. Some system environment configurations might prevent the concatenation. In that case, name the skeleton data set *hlq.IASNSLIB*, where *hlq* is the high-level qualifier that is used to install IMS. After it is named, the data set is automatically concatenated to ISPSLIB for all users of the IMS abend search and notification panel.

The installer of IMS abend search and notification must therefore have RACF ALTER authorization for the high-level qualifier that is used to install IMS. ALTER allows the installer to read, write, create, or delete the data set.

2. Access and fill out the IMS abend search and notification system setup ISPF panel to populate the runtime data set and skeleton data set.

The IMS abend search and notification system setup panel can be accessed by either of the following methods:

- Select **IMS abend search and notification** from the IMS Application Menu.
- From the ISPF option **6**, enter the following command, where *hlq* is the high-level qualifier used to install IMS:

```
exec 'hlq.SDFSEXEC(DFSASNO)' 'HLQ(hlq)'
```

The IMS Abend Search and Notification panel is displayed, as shown in the following example figure.

```
Command ==>          IMS Abend Search and Notification          IMS Version 12.1

                                                                TIME...10:58:45
                                                                DATE...2010/12/10
                                                                USERID..userid

Select one of the following tasks and press ENTER .

Tasks . . . 1. IMS ASN System Setup
             2. IMS ASN On-Demand Interface

To Exit this menu, press the END key.
For Help information, place cursor on any field and press PF1 .
```

Figure 24. IMS Abend Search and Notification panel

Type 1 in the field **IMS ASN System Setup** and press Enter. Here is an example of the IMS abend search and notification system setup panel:

```

IMS abend search and notification - system setup
COMMAND ==>

  Identify IMS ASN skeleton lib data set (must be concatenated to ISPSLIB):
*Skeleton lib DS -----

  Identify the following data sets and members (must be accessible at runtime):
*Runtime DS -----
*PROCLIB Mbr ----- Restore? _ *URLS Mbr ----- Restore? _
*SYSUT1 Mbr ----- Restore? _ *CONTROL Mbr ----- Restore? _
*SMS Mbr ----- Restore? _ *SMSCNTL Mbr ----- Restore? _

  Identify the fully qualified name of your installation's IMS.SDFSRESL:
*IMS.SDFSRESL DSN -----

  E-mail and Recipient Information
*Recipient e-mail address. . . -----
Specify additional addresses? _ (Y-Yes/N-No)
SMS recipient address . . . . -----
Specify additional SMS rcpts? _ (Y-Yes/N-No)
External Writer ID for Local SMTP -----
FROM e-mail -----
SMTP server ----- Port -----

```

Use the IMS abend search and notification system setup panel to perform the following tasks:

- Name and customize the IMS abend search and notification procedure JCL (the sample shipped in IMS.SDFSSLIB as DFSIASN0)
- Name and customize one or more SYSUT1 PDS members with the email message text. You can either use the IBM-supplied SYSUT1 PDS member as is, or customize it.
- Name and customize one or more CONTROL PDS members with email routing information. You can either use the IBM-supplied CONTROL PDS member as is, or customize it.
- Name and customize one or more SMS PDS members with the text for the text messages. You can either use the IBM-supplied SMS PDS member as is, or customize it.

Important: If you use the IBM-supplied SMS PDS member and you are running with CSSMTP instead of Communications Server SMTP on z/OS, you must remove the NOOP statement in the IBM-supplied SMS PDS member. The **NOOP** command is not supported in CSSMTP.

- Name and customize one or more SMSCNTL PDS members with the text-message routing information. You can either use the IBM-supplied SMSCNTL PDS member as is, or customize it.
- Name and customize one or more URLS PDS members with the URL information to be mapped into the email and text messages. You can either use the IBM-supplied URLS PDS member as is, or customize it.

The IMS Abend Search and Notification System Setup panel has general online help as well as field-sensitive online help. To access the online help, place the cursor on the command line (for general help) or in an input field (for field-sensitive help) and press F1.

For detailed information about the DFSIASN0 procedure and above PDS members, see [“DFSIASN0 procedure” on page 619](#).

3. Specify IASNPROC= *member_name* in the diagnostics section of the DFSDFxxx member of the IMS PROCLIB data set, where *member_name* is the eight-character name of the IMS abend search and notification procedure. This task can be performed using the Syntax Checker or by manually inserting the output of the IMS abend search and notification system setup panel (which resides in the DFSMSxxx member of the runtime data set) into the DFSDFxxx member of the IMS PROCLIB data set. For information about the DFSDFxxx member of the IMS PROCLIB data set, see [“DFSDFxxx member of the IMS PROCLIB data set” on page 756](#).
4. Copy the IMS abend search and notification procedure, which was created and customized through the use of the system setup panel, to a concatenated z/OS procedure library.
5. Provide the name of the skeleton data set to the users of the IMS abend search and notification on-demand interface by one of the following methods:

- Concatenate the data set name in the ISPSLIB DD statement in the logon procedures used by the TSO users
- Concatenate the data set name directly by statements in the default CLIST of those TSO users
- Name the skeleton data set using the format *hlq.IASNSLIB*, where *hlq* is the high-level qualifier that is used to install IMS. After it is named, the data set is automatically concatenated to ISPSLIB for all users of the IMS abend search and notification panel. If you perform setup a second time and use a data set name other than *hlq.IASNSLIB* for the skeleton data set, and *hlq.IASNSLIB* still exists, ISPF looks for the skeleton library members in *hlq.IASNSLIB* before looking in the other data set.
- Provide the TSO users a program that performs the concatenation

Results

To disable the IMS abend search and notification function, set *member_name* to blanks or a null value in the IASNPROC= parameter in the diagnostics section of the DFSDFxxx member of the IMS PROCLIB data set.

Customizing the IMS abend search and notification email

You can customize the email notification that is sent, adding a specific URL link, by modifying both the URLs and the SYSUT1 members.

About this task

You can access and modify the members by doing one of the following:

- Running the setup panel, which displays the customizable members in sequence for editing.
- Directly accessing the members in ISPF in the Runtime partitioned data set using the names specified in the setup panel.

To create a link to be inserted into the SYSUT1 member, modify the URLs member:

Procedure

1. Access the URLs member. The URLs member is the second member in sequence from setup panel.
2. Insert the link using the following format:

```
*This is a new link
#NEWURL,#PARM=(value1,value2)
http://www.new.com/
```

A sample is shown in the figure below.

The first line, which is preceded with an asterisk (*), is a comment line. Following the comment line is the name of the link, preceded with #. The name can be up to eight alphanumeric characters, including the #. Following the link name is the URL link to be associated with the name.

Optionally, you can specify a conditional statement, by specifying #PARM=(value1,value2,...). Use the following syntax:

- Specify a comma after the name to separate the name and the conditional statement.
- Following the comma, specify a parameter that exists in your particular customization, preceded with #.
- Following the parameter, specify "=" or "!=" depending on if you want to check for equality or inequality.
- Following the "=" sign or "!=", specify one or a set of values to be checked for the specified parameter, enclosed within parentheses.

A value cannot exceed 20 characters.

If you have multiple URLs with the same name, the foremost URL that satisfies the conditional statement is mapped into the formatted email.

For equality, if any of the value matches a part of the parameter's value, the conditional statement is satisfied. For inequality, if none of the value matches a part of the parameter's value, the conditional statement is satisfied.

Results

This creates a link that can be inserted into the SYSUT1 member to become part of the IMS ASN email

This link replaces any occurrence of the link name that exists in the SYSUT1 member, if no PARM conditions are specified or if the PARM conditions are satisfied. An example of how to insert the name into the SYSUT1 member is in the figure below.

```
-----
File Edit Edit_Settings Menu Utilities Compilers Test Help
-----
EDIT          IBMER.IASN.SDFSIAASN(DFSIAURL) - 01.01          Columns 00001 00072
Command ==>                                     Scroll ==> HALF
000052 http://www-1.ibm.com/support/docview.wss?rs=0&dc=DB540&q1=HMK1010
000053 &uid=isg1_IMS1010_HMK1010&loc=en_US&cs=utf-8&lang=
000054
000055 *Order PTF electronically
000056 #PTFURL
000057 https://techsupport.services.ibm.com/server/390.elecptforder
000058
000059 *New Link
000060 #MSGURL,#MSG=(BPE,CQS,CSL,DHB,DFS,DSP,DXR,ELX,HWS,MDA,PCB,PGEN)
000061 http://www.ibm.com/support/knowledgecenter/SSEPH2/welcome
-----
```

Figure 25. Adding an email link in the IMS Abend Search and Notification panel using the URSL member

```
-----
File Edit Edit_Settings Menu Utilities Compilers Test Help
-----
EDIT          KINLAU.IASN.SDFSIAASN(DFSIAEML) - 01.02          Columns 00001 00072
Command ==>                                     Scroll ==> HALF
000204 <li>
000205 <a href="
000206 #GENURL
000207 ">General search results for #GEN
000208 </a></li>
000209 %GEN
000210 </ul></font>
000211 </td></tr></table>
000212 </td>
000213 </tr>
000214 <tr>
000215 <td width="375">
000216 <table border="0" cellspacing="0" cellpadding="5"><tr><td>
000217 <font size="-2" face="Verdana, Arial, Helvetica, sans-serif">
000218 <a href="
000219 #PSPURL
000220 ">Search the
000221 Preventative Maintenance Planning (PSP) Database</a>
000222 for specific installation tips, high impact or pervasive problems
000223 and service recommendations.</font><br>
-----
```

Figure 26. HTML formatting using the URSL member

To add a link in the email using the SYSUT1 member:

1. Access the SYSUT1 member. The SYSUT1 member is the third member in sequence from the setup panel and follows the URLs member.
2. Scroll down to the text and HTML sections. These two sections are marked by "Content-Type: text/plain" and "Content-Type: text/html", respectively.
3. Add the following text in the text section.

```
9. This is a new link
#NEWURL
```

4. Add the HTML syntax in the HTML section. You must follow HTML syntax rules in the HTML section.

```
<li>
<a href="
#NEWURL
">This is a new link.
</a></li>
```

In the HTML section, the name of the link #NEWURL must be on a line by itself.

This creates a link at the bottom of the list in each IMS ASN email.

```
-----
File Edit Edit_Settings Menu Utilities Compilers Test Help
-----
EDIT          KINLAU.IASN.SDFSIAASN(DFSIAEML) - 01.01          Columns 00001 00072
Command ==>                                     Scroll ==> HALF
000078
000079 8. General search results for #GEN
000080 #GENURL
000081 %GEN
000082
000083 9. This is a new link
000084 #NEWURL
000085
000086 -----
000087
000088 Search the Preventative Maintenance Planning (PSP) Database
000089 #PSPURL
000090 for specific installation tips, high impact or pervasive
000091 problems and service recommendations.
000092
000093 Can't find an answer?
000094 Contact our support team at:
000095 https://www.ibm.com/support/servicerequest/Home.action
000096
000097 Looking for fixes?
-----
```

Figure 27. Adding an email link in the IMS Abend Search and Notification panel using the SYSUT1 member

```
-----
File Edit Edit_Settings Menu Utilities Compilers Test Help
-----
EDIT          KINLAU.IASN.SDFSIAASN(DFSIAEML) - 01.01          Columns 00001 00072
Command ==>                                     Scroll ==> HALF
000204      <li>
000205 <a href="
000206 #GENURL
000207 ">General search results for #GEN
000208 </a></li>
000209 %GEN
000210      <li>
000211 <a href="
000212 #NEWURL
000213 ">This is a new link.
000214 </a></li>
000215      </ul></font>
000216      </td></tr></table>
000217      </td>
000218 </tr>
000219 <tr>
000220 <td width="375">
000221 <table border="0" cellspacing="0" cellpadding="5"><tr><td>
000222 <font size="-2" face="Verdana, Arial, Helvetica, sans-serif">
000223 <a href="
-----
```

Figure 28. HTML formatting using the SYSUT1 member

Chapter 16. IMS system definition examples

The examples of IMS system definitions provided here reflect stage 1 input to the assembler during an IMS system definition.

The IMS system definition macro statements shown in the following example are the only statements necessary for the system definition for a z/OS database system.

Characteristics to define	Macro statements prepared	Column 72
IMS Configuration	IMSCTRL SYSTEM=(VS/2,(BATCH,DB/DC),390) IMSGEN ASM=HLASM,ASMPRT=ON, LKPRT=(XREF,LIST), JOBCTL=(4,C,T), PRTY=6,PROCLIB=YES	X X X

IMS DB/DC environment

This example of an IMS DB/DC system definition includes definitions for data communication, system configuration, databases, and application programs.

A sample IMS DB/DC environment is the basis for this example of an IMS DB/DC system definition. An overview of the IMS system is followed by system details and macros.

In this example, the system has the following characteristics:

- 46 application programs
- 67 transaction codes against those application programs
- 16 databases

Data communication characteristics

The line groups and terminals that comprise the example IMS DB/DC system definition are provided.

The data communication characteristics of the sample environment include:

- Four local SYSOUT line groups
- Six 3270 local VTAM terminals
- Six 3270 remote VTAM terminals
- Five 3600 (or FINANCE) VTAM terminals
- Three SLU 1 VTAM terminals
- Two NTO terminals
- Two SLU 2 VTAM terminals
- Two SLU P VTAM terminals
- Two LU 6.1 VTAM terminals

System configuration macro statements

The macro statements associated with the example of the IMS DB/DC system definition are provided.

The system configuration macros in “[Sample system configuration macro statements](#)” on page 356 select IMS system functions for z/OS, allowing five regions to operate simultaneously. They specify 16 transaction code classes, and the number of concurrently operating subtasks optimized to equal the number of specified communication lines divided by two.

Sample system configuration macro statements

Characteristics to define	Macro statements prepared	Column 72
IMS Configuration	IMSCTRL SYSTEM=(VS/2,(ALL,DB/DC),390), MAXREGN=(5,52K,A,3), MCS=13,DESC=2,MAXCLAS=16, IMSID=IMSA	X X X
Data Sets	MSGQUEUE DSETS=LGDK, BUFFERS=(20,1152), SHUTDOWN=150	X X

Database and application macro statements

The macro statements associated with the databases and application programs of the example IMS DB/DC system definition are provided.

The macro statements shown in [“Sample database and application macro statements”](#) on page 356 define DL/I databases.

Sample database and application macro statements

Characteristics to define	Macro statements prepared	Column 72
DL/I Databases		
DH41SK01, DH41SK02, DH41TS01	DATABASE DBD=(DH41SK01,DH41SK02,DH41TS01)	
DI31LM01	DATABASE DBD=DI31LM01	
DI21PART, DH41SK03, DX41SK01	DATABASE RESIDENT, DBD=(DI21PART,DH41SK03,DX41SK01)	X
DI41SK01, DI41SK02	DATABASE DBD=(DI41SK01,DI41SK02)	
DD41SK01, DD41TS01, DX41TS01	DATABASE DBD=(DD41SK01,DD41TS01,DX41TS01)	
LTERMINL, LTINDEXDB	DATABASE DBD=(LTERMINL,LTINDEXDB)	
TESTABLE, TTINDEXDB	DATABASE DBD=(TESTABLE,TTINDEXDB)	

DL/I application programs

An example of the macro statements that can be used to define the characteristics associated with DL/I application programs is provided.

In the following example, each DL/I application program is shown with associated transaction codes and macros.

Characteristics to define	Macro statements prepared	Column 72
Programs and Transaction Codes		
HSBASK41 (Batch)	APPLCTN PSB=HSBASK41,PGMTYPE=BATCH	
HIMAJC01 TPPL1	APPLCTN PSB=HIMAJC01 TRANSACTION CODE=TPPL1,PRTY=(8,8)	

HIMAJC03	APPLCTN PSB=HIMAJC03	
TUBE	TRANSACT CODE=TUBE,PRTY=(8,8), SPA=100,MODE=SNGL	X
TUBFD	TRANSACT CODE=TUBFD,PRTY=(8,8), SPA=100, MODE=SNGL	X X
TUBFC	TRANSACT CODE=TUBFC,PRTY=(8,8), SPA=100, MODE=SNGL	X X
TUBMA	TRANSACT CODE=TUBMA,PRTY=(8,8), SPA=20000,MODE=SN GL	X
HIMALM01	APPLCTN PSB=HIMALM01, SCHDTYP=PARALLEL	X
DLI	TRANSACT CODE=DLI,PRTY=(5,10,5), PROCLIM=(10,10), MSGTYPE=(SNGLSEG,RESPONSE)	X X
ICS	TRANSACT CODE=ICS,PRTY=(5,12,5), PROCLIM=(10,100), MODE=SNGL	X X
DLN	TRANSACT CODE=DLN,PRTY=(0,8,3), PROCLIM=(10,100)	X
IMS	TRANSACT CODE=IMS,PRTY=(5,12,5), PROCLIM=(1,100), MSGTYPE=SNGLSEG,PARLIM=1	X X
CONALTR	APPLCTN PSB=CONALTR	
CONAL	TRANSACT CODE=CONAL,MODE=SNGL, PRTY=(8,8),SPA=100	X
CONALF	TRANSACT CODE=CONALF,MODE=SNGL, PRTY=(8,8), SPA=100	X X
LKMDFS00	APPLCTN PSB=LKMDFS00	
STL	TRANSACT CODE=STL,PRTY=(5,12,5), PROCLIM=(8,100),INQ=YES	X
LKMDFS10	APPLCTN PSB=LKMDFS10,PGMTYPE=BATCH	
LKM	TRANSACT CODE=LKM,PRTY=(0,0), MSGTYPE=SNGLSEG	X
MR1	APPLCTN PSB=MR1	
MR1	TRANSACT CODE=MR1,PRTY=(8,8)	
MR2	APPLCTN PSB=MR2	
MR2	TRANSACT CODE=MR2,PRTY=(8,8)	
MR3	APPLCTN PSB=MR3	
MR3	TRANSACT CODE=MR3,PRTY=(8,8)	
MR4	APPLCTN PSB=MR4	
MR4	TRANSACT CODE=MR4,PRTY=(8,8)	
MR5	APPLCTN PSB=MR5	
MR5	TRANSACT CODE=MR5,PRTY=(8,8)	

Characteristics to define	Macro statements prepared	Column 72
Programs and Transaction Codes		
MR6	APPLCTN PSB=MR6	
MR6	TRANSACT CODE=MR6,PRTY=(8,8)	
TESTIMSD	APPLCTN PSB=TESTIMSD	
TSTCONV	TRANSACT CODE=TSTCONV,PRTY=(8,8), SPA=100,MODE=SN GL	X
TSTNORM	TRANSACT CODE=TSTNORM,PRTY=(8,8)	
REQIMSD	APPLCTN PSB=REQIMSD	
TREQ	TRANSACT CODE=TREQ,PRTY=(8,8), SPA=100,MODE=SNGL	X
LOADLT (Batch)	APPLCTN PSB=LOADLT,PGMTYPE=BATCH	
LOADTT (Batch)	APPLCTN PSB=LOADTT,PGMTYPE=BATCH	

STLECHO	APPLCTN PSB=STLECHO	
ECHO	TRANSACT CODE=ECHO, PRTY=(5,10,5),	X
	PROCLIM=(10,10),	X
	MSGTYPE=SNGLSEG	
ECHO	TRANSACT CODE=ECHO, PRTY=(5,10,5),	X
	PROCLIM=(10,10)	
MR8	APPLCTN PSB=MR8	
MR8	TRANSACT CODE=MR8, PRTY=(8,8)	

Characteristics to define	Macro statements prepared	Column 72
Programs and Transaction Codes		
RESIDENT PSBS		
RESPSB1	APPLCTN PSB=RESPSB1, RESIDENT	
RESPSB	TRANSACT CODE=RESPSB, PRTY=(8,8)	
RESBAL01	APPLCTN PSB=RESBAL01,	X
	SCHDTYP=PARALLEL, RESIDENT	
BAL01	TRANSACT CODE=(BAL01, BAL02, BAL03),	X
	PRTY=(8,8)	
BAL02		
BAL03		
RESBAL02	APPLCTN PSB=RESBAL02,	X
	SCHDTYP=PARALLEL	
BALTRAN	TRANSACT CODE=BALTRAN, PRTY=(8,8),	X
	PARLIM=1	
PSBEXINT	APPLCTN PSB=PSBEXINT	
TRANEXNT	TRANSACT CODE=TRANEXNT, PRTY=(8,8)	
INTCON	APPLCTN PSB=INTCON	
ANY	TRANSACT CODE=ANY, PRTY=(8,8), SCHD=3	
HI	TRANSACT CODE=HI, PRTY=(8,8), SCHD=2	
EQHI	TRANSACT CODE=EQHI, PRTY=(8,8),	X
	SCHD=1	
NXCLASS	TRANSACT CODE=NXCLASS, PRTY=(8,8),	X
	SCHD=4	
CUTOFF	APPLCTN PSB=CUTOFF	
SIX	TRANSACT CODE=SIX, PRTY=(6,6)	
SEVEN	TRANSACT CODE=SEVEN, PRTY=(7,7)	
EIGHT	TRANSACT CODE=EIGHT, PRTY=(8,8)	
NINE	TRANSACT CODE=NINE, PRTY=(9,9)	
NXTCLASS	APPLCTN PSB=NXTCLASS, PGMTYPE=(, , 2)	
ONE	TRANSACT CODE=ONE, PRTY=(1,1)	

The system includes one 3600 application program.

Characteristics to define	Macro statements prepared	Column 72
Programs and Transaction Codes		
TEST3600	APPLCTN DOPT, PSB=TEST3600,	X
	PGMTYPE=TP	
CIFINQ	TRANSACT CODE=CIFINQ, PRTY=(1,2,2),	X
	MSGTYPE=SNGLSEG,	X
	PROCLIM=(, 30), INQUIRY=YES,	X
	SEGNO=256, SEGSIZE=4096	
SAVDBT	TRANSACT CODE=(SAVDBT, SAVDPT),	X
	PRTY=(1,2,2),	X
	MSGTYPE=SNGLSEG,	X
	PROCLIM=(, 30), INQUIRY=NO,	X
	SEGNO=10, SEGSIZE=80	
BRNCHTOT	TRANSACT CODE=BRNCHTOT,	X
	PRTY=(1,2,2), MSGTYPE=SNGLSEG,	X
	PROCLIM=(, 30), INQUIRY=YES,	X

SEGNO=256,SEGSIZE=132		
PGM3741 TX3741	APPLCTN PSB=PGM3741,PGMTYPE=TP TRANSACT CODE=TX3741	
DFSSAM02 PART	APPLCTN PSB=DFSSAM02, PGMTYPE=(TP,,4) TRANSACT CODE=PART,PRTY=(7,10,2), INQ=(YES,NORECOV)	X X
DFSSAM03 DSPINV	APPLCTN PSB=DFSSAM03 TRANSACT CODE=DSPINV,PRTY=(7,10,2), INQ=YES,MSGTYPE=(,4)	X
DFSSAM04 ADDPART	APPLCTN PSB=DFSSAM04,PGMTYPE=(,4) TRANSACT CODE=(ADDPART,DLETPART), PRTY=(7,10,2)	X
DLETPART ADDINV	TRANSACT CODE=(ADDINV,DLETINV), PRTY=(7,10,2),MSGTYPE=(,5)	X
DLETINV		
DFSSAM05 CLOSE	APPLCTN PSB=DFSSAM05,PGMTYPE=(,3) TRANSACT CODE=CLOSE,PRTY=(7,10,2)	
DFSSAM06 DISBURSE	APPLCTN PSB=DFSSAM06 TRANSACT CODE=DISBURSE, PRTY=(7,10,2),MSGTYPE=(,2)	X
DFSSAM07 DSPALLI	APPLCTN PSB=DFSSAM07,PGMTYPE=(,2) TRANSACT CODE=DSPALLI, PRTY=(7,10,2),INQ=YES	X

Data Communication macro statements

These topics describe several line group configurations and include the required macro statements for each configuration.

Local SYSOUT line groups

Macro statements to define local SYSOUT line groups are provided in this topic.

Figure 29 on page 360 shows local SYSOUT line groups.

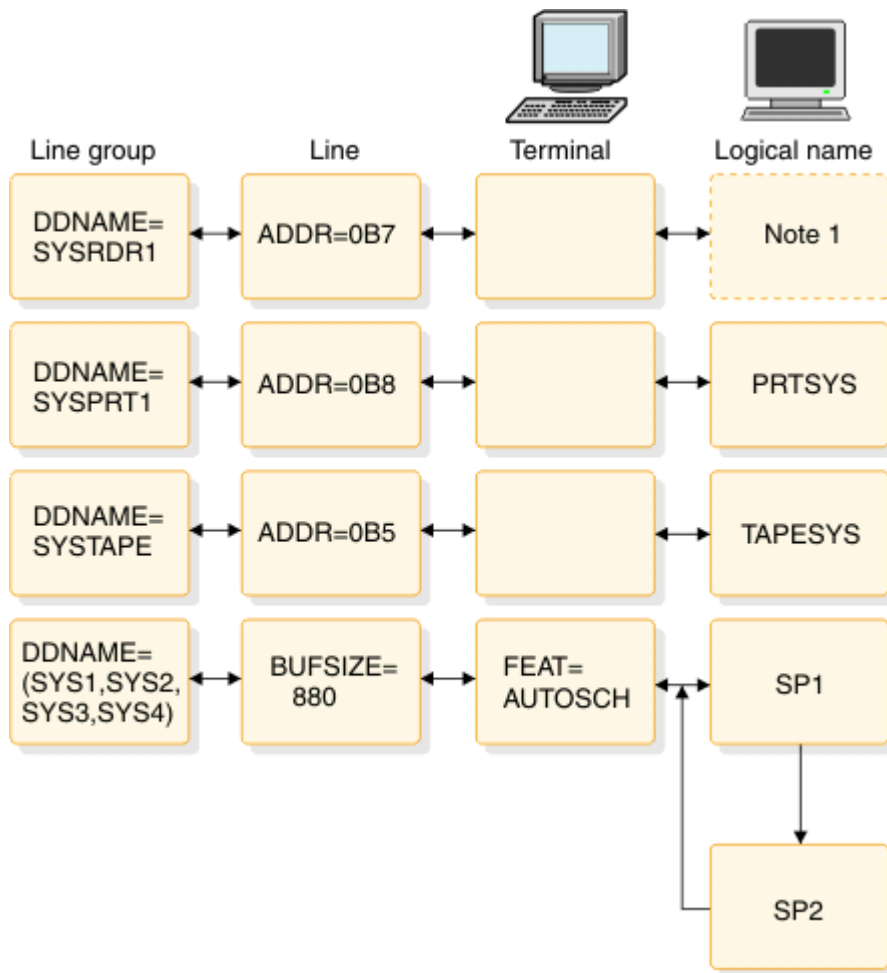

Figure 29. Local SYSOUT line groups

Sample macro statements for local SYSOUT line group

```

LINEGRP DDNAME=SYSRDR1, UNITYPE=READER
LINE ADDR=0B7
TERMINAL LTERM=LCLDR1
LINEGRP DDNAME=SYSPRT1, UNITYPE=PRINTER
LINE ADDR=0B8
TERMINAL
NAME PRTSYS
LINEGRP DDNAME=SYSTAPE, UNITYPE=TAPE
LINE ADDR=0B5, BUFSIZE=220
TERMINAL
NAME TAPESYS
LINEGRP UNITYPE=SP00L, DDNAME=(SYS1, SYS2, SYS3, SYS4)
LINE BUFSIZE=880
TERMINAL FEAT=AUTOSCH
NAME SP1, SP2

```

Macro statements to define VTAM communication devices

Examples of system definition macro statements to define VTAM communication devices are provided in these topics.

The following sets of VTAM macro statements describe the VTAM communication devices. A graphic representation of each of these is presented, along with the macro statements required to define it.

COMM macro statement

A sample COMM macro statement is provided.

The COMM macro statement shown in [“Sample COMM macro statement”](#) on page 361 can only appear once in an IMS system definition. When VTAM is included in a system, the COMM macro statement is required.

Sample COMM macro statement

Macro statement set	Column	72
COMM	RECANY=(4,500),APPLID=IMSD, OPTIONS=(TIMESTAMP,MFSTEST,FMTMAST,PAGING)	X

Macro statements to define local 3270 VTAM terminals

Sample macro statements to define local 3270 VTAM terminals are provided.

[Figure 30 on page 362](#) illustrates macro statements for a local 3270 VTAM terminal.

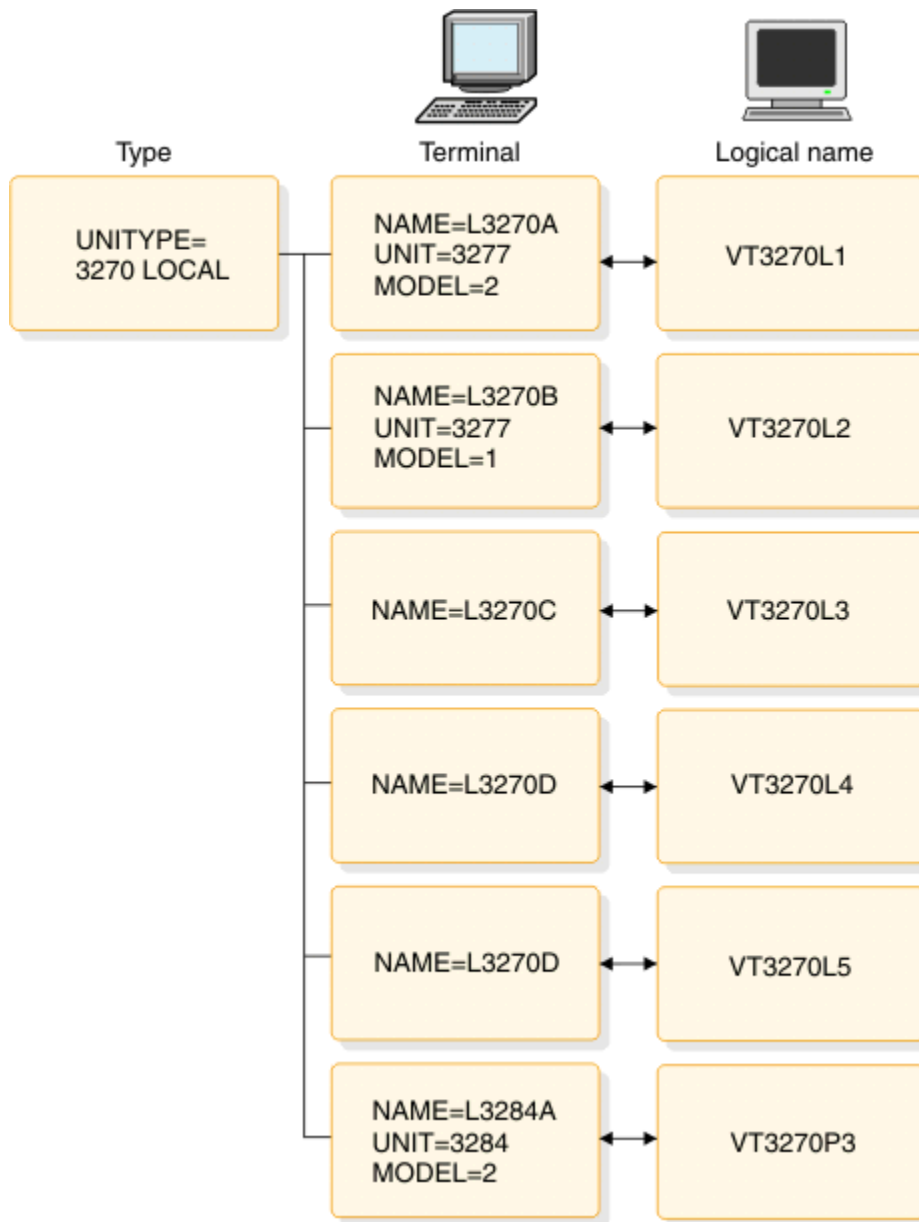

Figure 30. Local 3270 VTAM terminal

“Sample macro statements to define 3270 VTAM terminals” on page 362 shows the macro statements to define local 3270 VTAM terminals.

Sample macro statements to define 3270 VTAM terminals

```

TYPE UNITYPE=(3270,LOCAL),MODEL=2
TERMINAL NAME=L3270A
NAME (VT3270L1,MASTER)
TERMINAL NAME=L3270B,MODEL=1,OPTIONS=FORCRESP
NAME VT3270L2
TERMINAL NAME=L3270C,TYPE=3270-A2,SIZE=(24,80)
NAME VT3270L3
TERMINAL NAME=L3270D,TYPE=3270-A3,SIZE=(32,80)
NAME VT3270L4
TERMINAL NAME=L3270E,TYPE=3270-A4,SIZE=(43,80)
NAME VT3270L5
TERMINAL NAME=L3284A,UNIT=3284,PTRSIZE=132
NAME (VT3270P3,SECONDARY)

```

Macro statements to define remote 3270 VTAM terminals

Examples of macro statements used to define remote 3270 VTAM terminals are provided.

Figure 31 on page 363 illustrates macro statements for remote 3270 VTAM terminals.

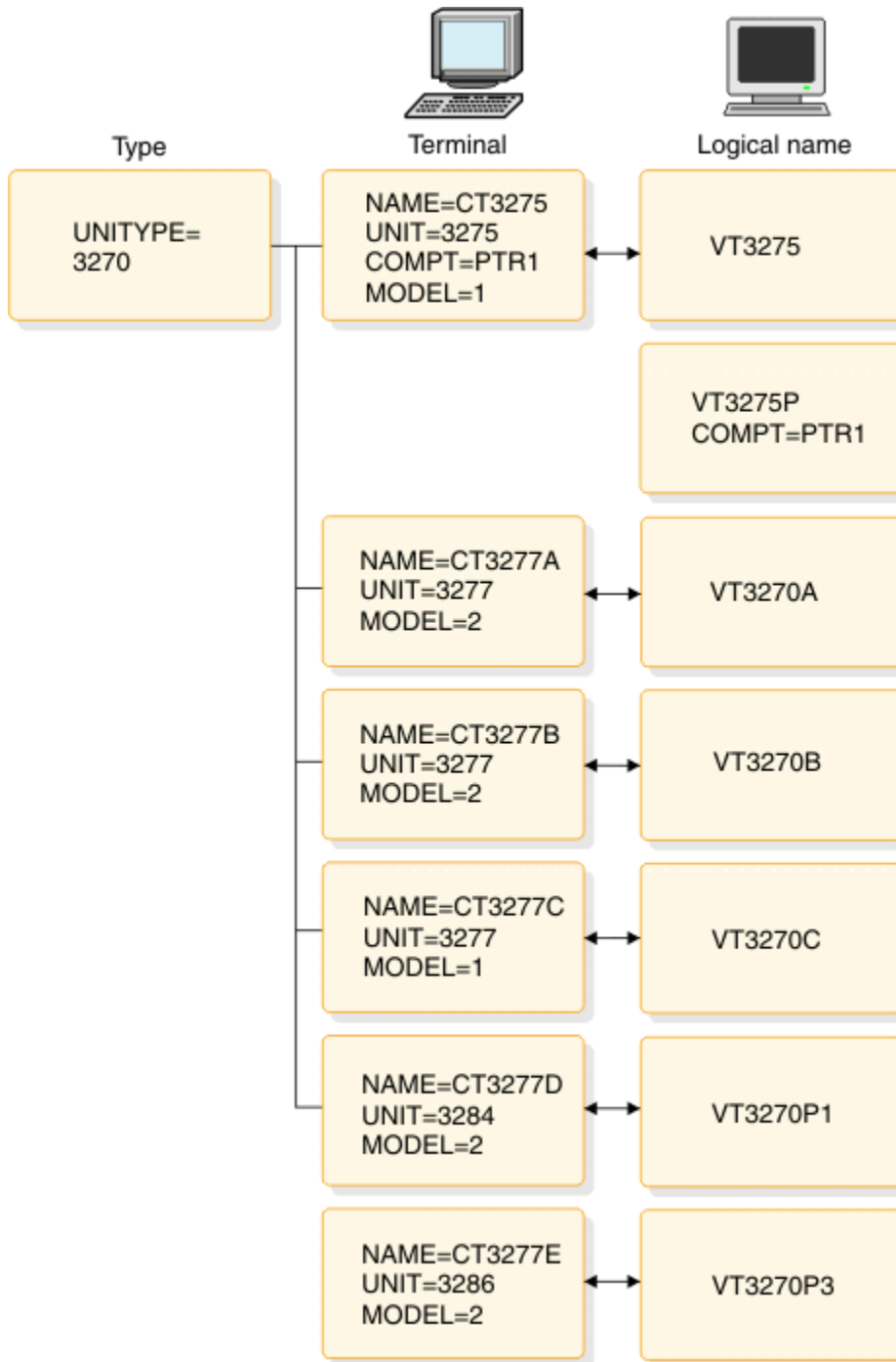

Figure 31. Remote 3270 VTAM terminals

“Sample macro statements to define remote 3270 VTAM terminals” on page 363 shows the macro statements to define remote 3270 VTAM terminals.

Sample macro statements to define remote 3270 VTAM terminals

```
TYPE UNITYPE=3270,MODEL=2,PTRSIZE=132,OPTIONS=COPY
TERMINAL NAME=CT3275,UNIT=3275,COMPT=PTR1,MODEL=1
```

```
NAME VT3275
NAME VT3275P,COMPT=PTR1
TERMINAL NAME=CT3277A
NAME VT3270A
TERMINAL NAME=CT3277B
NAME VT3270B
TERMINAL NAME=CT3277C,MODEL=1
NAME VT3270C
TERMINAL NAME=CT3277D,UNIT=3284
NAME VT3270P1
SPACE
TERMINAL NAME=CT3277E,UNIT=3286
NAME VT3270P2
```

Macro statements to define a finance communication system

Examples of macro statements that can be used to define a finance communication system are provided.

[Figure 32 on page 365](#) illustrates macro statements for a finance communication system.

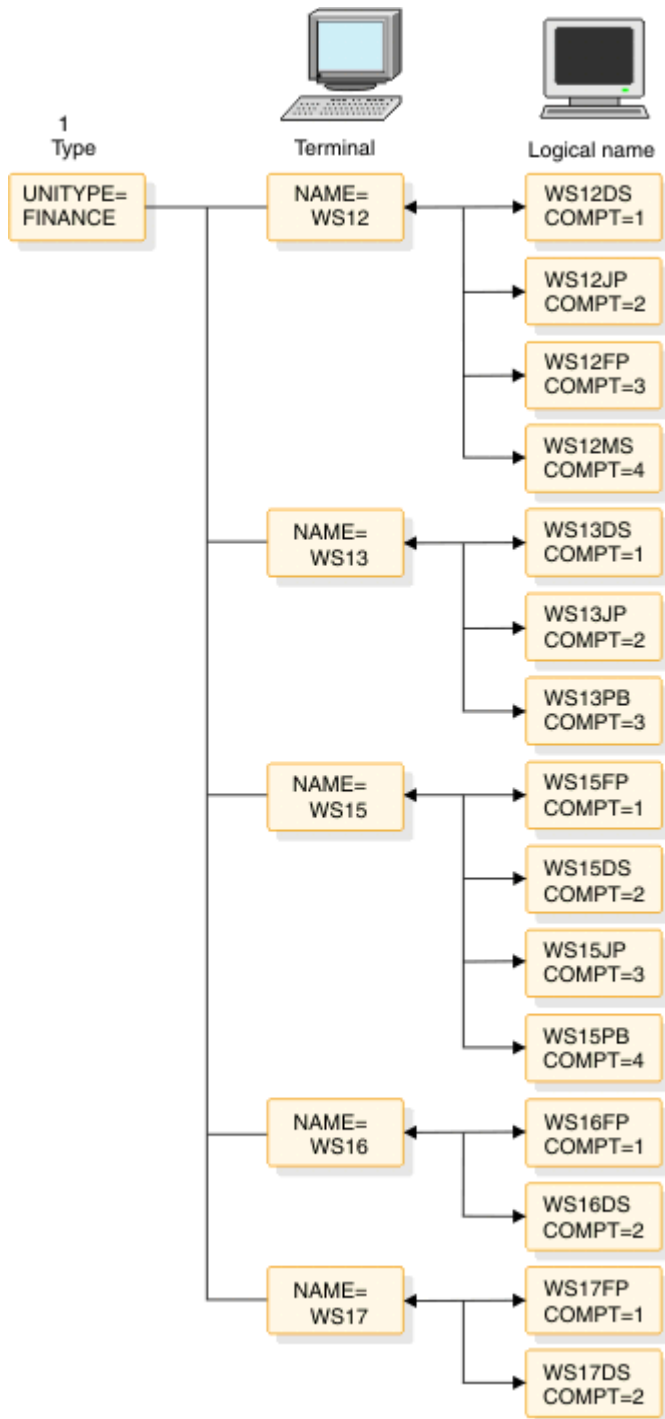

Figure 32. Finance Communication system

“Sample macro statements to define a finance communication system” on page 365 shows the macro statements to define a finance communication system.

Sample macro statements to define a finance communication system

Macro statement set	Column
	72
TYPE UNITYTYPE=FINANCE ,OUTBUF=256	
TERMINAL NAME=WS12 ,OPTIONS=MFS	
COMPT=(36DS3 ,36JP ,36FP ,36MS) ,FEAT=(DUAL ,132)	
NAME WS12DS ,COMPT=1	
NAME WS12JP ,COMPT=2	
NAME WS12FP ,COMPT=3	

```

NAME WS12MS,COMPT=4
TERMINAL NAME=WS13,OPTIONS=(MFS,NOPNDST,OPTACK), X
      COMPT=(36DS4,36JP,36PB)
NAME WS13DS,COMPT=1
NAME WS13JP,COMPT=2
NAME WS13PB,COMPT=3
TERMINAL NAME=WS15,COMPT=(36FP,36DS,36JP,36PB), X
      OPTIONS=MFS
NAME WS15FP,COMPT=1
NAME WS15DS,COMPT=2
NAME WS15JP,COMPT=3
NAME WS15PB,COMPT=4
TERMINAL NAME=WS16,COMPT=(36FP,36DS4), X
      OPTIONS=(FORCRESP,MFS,OPTACK,BID,OPNDST)
NAME WS16FP,COMPT=1
NAME WS16DS,COMPT=2
TERMINAL NAME=WS17,COMPT=(36FP,36DS), X
      OPTIONS=(ACK,NOBID,TRANRESP,NOPNDST)
NAME WS17FP,COMPT=1
NAME WS17DS,COMPT=2

```

Macro statements to define secondary logical unit type 1 VTAM terminals

Examples of macro statements that can be used to define secondary logical unit type 1 VTAM terminals are provided.

Figure 33 on page 366 illustrates the macro statements for a secondary logical unit type 1 VTAM terminal.

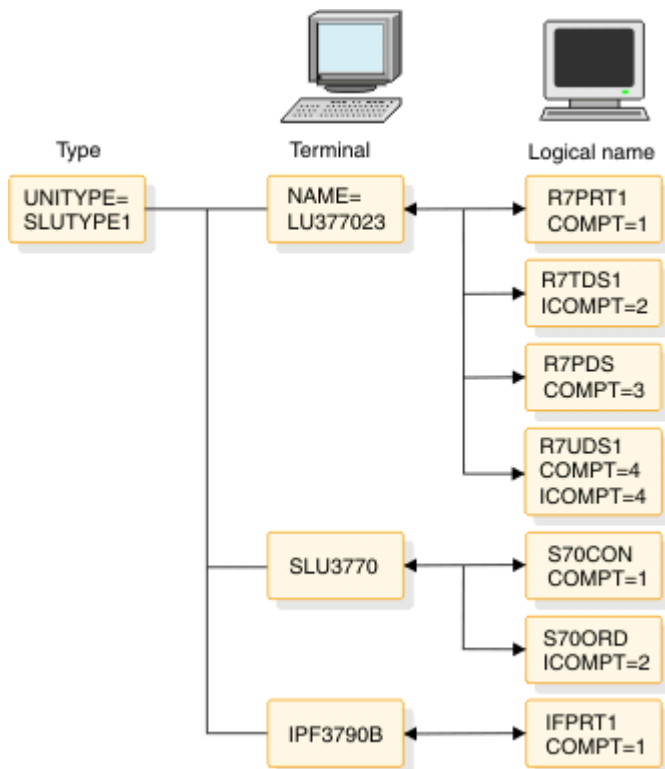

Figure 33. Secondary logical unit type 1 VTAM terminals

“Sample macro statements to define SLU type 1 VTAM terminals” on page 366 shows the macro statements to define SLU Type 1 VTAM terminals.

Sample macro statements to define SLU type 1 VTAM terminals

Macro statement set	Column
TYPE UNITYTYPE=SLUTYPE1	72
TERMINAL NAME=LU377023,	X
COMPT1=(PRINTER1,BASIC-SCS1),	X
COMPT2=(TRANSDS1,BASIC-SCS2),	X

```

COMPT3=(PRINTDS1,BASIC-SCS1),
COMPT4=(USERDS1,BASIC)
NAME R7PRT1,COMPT=1
NAME R7TDS1,ICOMPT=2
NAME R7PDS1,COMPT=3
NAME R7UDS1,COMPT=4,ICOMPT=4
TERMINAL NAME=SLU3770,COMPT1=(CONSOLE,MFS-SCS1),
COMPT2=(READER1,MFS-SCS2,3)
NAME S70CON,COMPT=1
NAME S70RDR,ICOMPT=2
TERMINAL NAME=IFP3790B,
COMPT1=(PRINTER1,BASIC-SCS1),
OPTIONS=(OPNDST,NBSELM)
NAME IFPRT1,COMPT=1

```

Macro statements to define NTO devices

Examples of macro statements that can be used to define Network Terminal Option (NTO) devices are provided.

Figure 34 on page 367 illustrates macro statements for NTO devices.

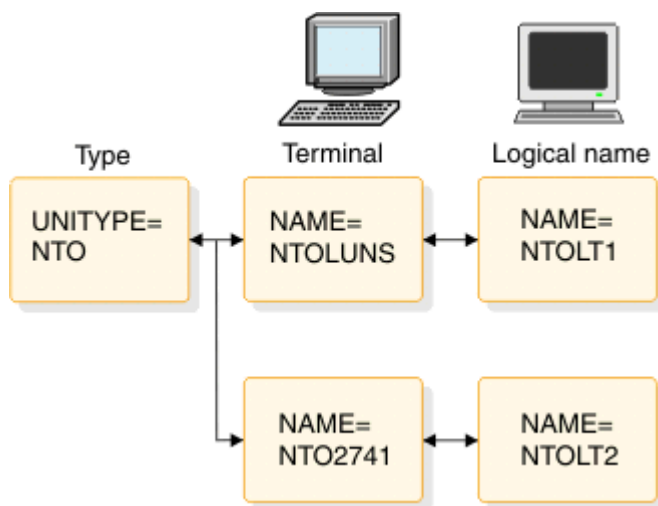

Figure 34. NTO devices

“Sample macro statements to define NTO devices” on page 367 shows the macro statements to define NTO devices.

Sample macro statements to define NTO devices

Macro statement set	Column
TYPE UNITYPE=NT0,EDIT=(EDIT1,EDIT2)	72
TERMINAL NAME=NTOLUNS,EDIT=(YES,YES), OUTBUF=300,SEGSIZE=300,PU=LUNS,OPTIONS=OPNDST	X
NAME NTOLT1	
TERMINAL NAME=NT02741,PU=2741, MSGDEL=NONIOPCB,OPTIONS=(NORESP,MFS)	X
NAME NTOLT2	

Macro statements to define secondary logical unit type 2 VTAM terminals

Examples of macro statements that can be used to define secondary logical unit type 2 VTAM terminals are provided.

Figure 35 on page 368 illustrates macro statements for secondary logical unit Type 2 VTAM terminals.

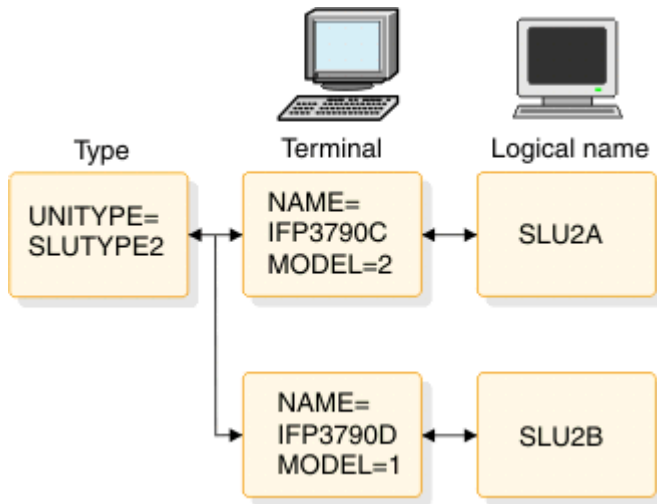

Figure 35. Secondary logical unit type 2 VTAM terminals

“Macro statements to define SLU type 2 VTAM terminals” on page 368 shows the macro statements to define SLU type 2 VTAM terminals.

Macro statements to define SLU type 2 VTAM terminals

```

TYPE UNITYPE=SLUTYPE2,MODETBL=AAA
TERMINAL NAME=IFP3790C,MODEL=2,MODETBL=BBB
NAME SLU2A
TERMINAL NAME=IFP3790D,MODEL=1,OUTBUF=500
NAME SLU2B

```

Macro statements to define secondary logical unit type P VTAM terminals

Examples of macro statements that can be used to define secondary logical unit type P VTAM terminals are provided.

Figure 36 on page 368 illustrates the macro statements for secondary logical unit type P VTAM terminals.

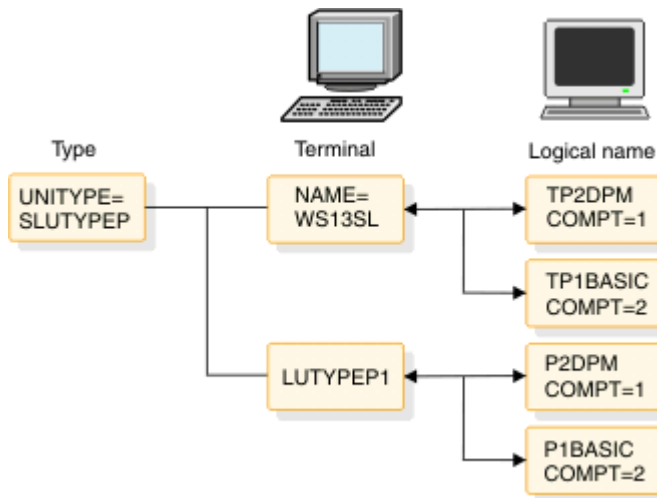

Figure 36. Secondary logical unit type P VTAM terminal

“Sample macro statements to define SLU type P VTAM terminals” on page 369 shows the macro statements to define SLU Type P VTAM terminals.

Sample macro statements to define SLU type P VTAM terminals

Macro statement set	Column
TYPE UNITYPE=SLUTYPEP,OUTBUF=256, OPTIONS=(OPTACK,NOBID)	72 X
TERMINAL NAME=WS13SL, COMPT1=(PROGRAM2,DPM-A1,4), COMPT2=(PROGRAM1,BASIC)	X X
NAME TP2DPM,COMPT=1	
NAME TP1BASIC,COMPT=2	
TERMINAL NAME=LUTYPEP1, COMPT1=(PROGRAM2,DPM-A1,IGNORE), COMPT2=(PROGRAM1,DPM-A3,2), COMPT3=PROGRAM1	X X X
NAME P2DPM,COMPT=1	
NAME P1BASIC,COMPT=2	

Macro statements to define logical unit type 6 VTAM terminals

Examples of macro statements that can be used to define logical unit type 6 VTAM terminals are provided.

[Figure 37 on page 370](#) shows the macro statements for Logical Unit Type 6 VTAM terminals.

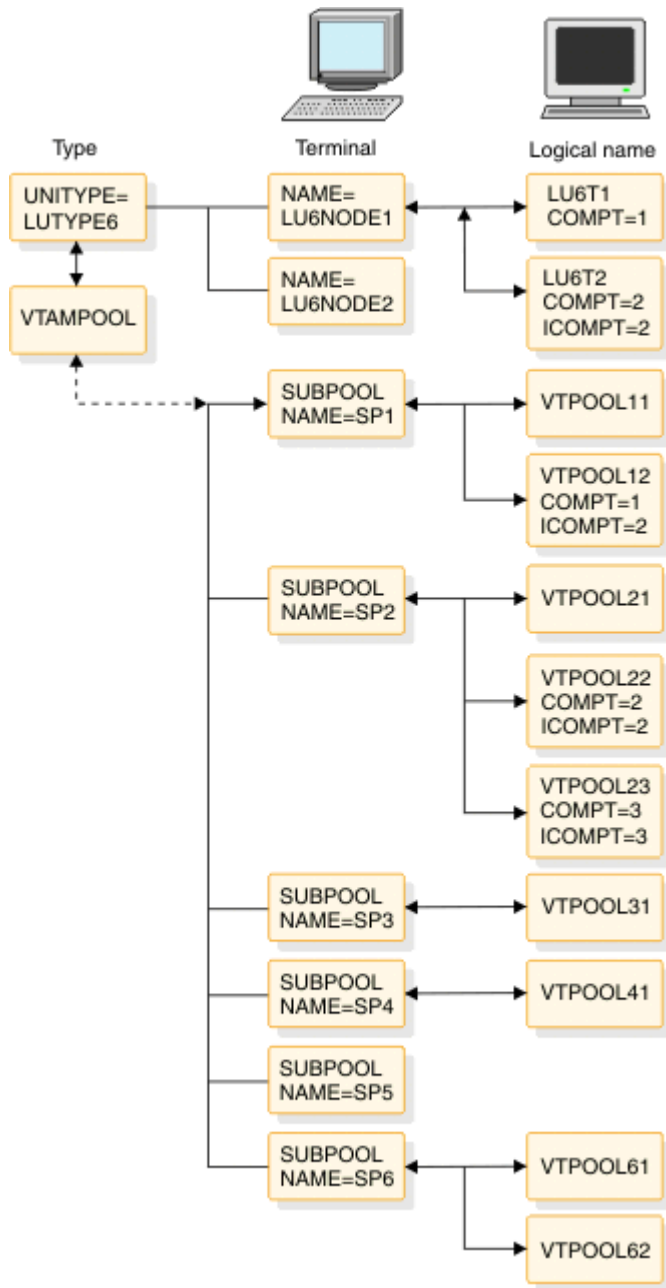

Figure 37. Logical unit type 6 VTAM terminals

“Sample macro statements to define LU type 6 VTAM terminals” on page 370 shows the macro statements to define LU type 6 VTAM terminals.

Sample macro statements to define LU type 6 VTAM terminals

Macro statement set	Column 72
TYPE UNITYPE=LUTYPE6	
*LU 6 NODE DEFINITION WITH FIXED LTERM ALLOCATION	
TERMINAL NAME=LU6NODE1,OPTIONS=NORESP,	X
COMPT1=(MULT2,DPM-B1,4),	X
COMPT2=(SINGLE2,VLVB)	
NAME LU6T1,COMPT=1	
NAME LU6T2,COMPT=2,ICOMPT=2	
*LU 6 NODE DEFINITION -- PARALLEL SESSIONS WITH DYNAMIC LTERM ALLOCATION	

```

TERMINAL NAME=LU6NODE2,OPTIONS=TRANRESP, X
COMPT1=(SINGLE1,DPM-B1,IGNORE), X
COMPT2=(SINGLE2,DPM-B3,2), X
COMPT3=MULT1, X
SESSION=3

VTAMPOOL
SUBPOOL NAME=SP1
NAME VTPOOL11
NAME VTPOOL12,COMPT=1,ICOMPT=2
SUBPOOL NAME=SP2
NAME VTPOOL21
NAME VTPOOL22,COMPT=2,ICOMPT=2
NAME VTPOOL23,COMPT=3,ICOMPT=3
SUBPOOL NAME=SP3
NAME VTPOOL31
SUBPOOL NAME=SP4
NAME VTPOOL41
SUBPOOL NAME=SP5
SUBPOOL NAME=SP6
NAME VTPOOL61
NAME VTPOOL62

```

System configuration macro statement

An example of IMSGEN, a macro statement that can be used to configure an IMS system, is provided.

In this example, the IMSGEN macro statement must be last in the IMS system definition input stream. The IMSGEN macro statement for that sample system is shown in [“Sample system configuration macro statement”](#) on page 371.

Sample system configuration macro statement

Characteristics to define	Macro statements prepared	Column 72
IMS Configuration	IMSGEN ASM=HLASM,	X
	ASMPRT=ON,	X
	LKPRT=(XREF,LIST),	X
	LKSIZE=(200K,28K),	X
	LKRGN=200K,	X
	SUFFIX=0,	X
	OBJDSET=IMS.OBJDSET,	X
	NODE=IMS,	X
	SCL=4,	X
	JCL=(SYSDEF,	X
	(A100,B20,M7044L21,'T=MAC'),	X
	MACKAY,0,(MSGLEVEL=(1,1),	X
	CLASS=N))	

IMS Multiple Systems Coupling system definition examples

Examples of system definitions for IMS Multiple Systems Coupling (MSC) are provided in this topic.

The Multiple Systems Coupling (MSC) sample shown in the following figure includes the relevant macros from the system definition of each of the three systems in a sample multiple-IMS system configuration. The multiple-systems configuration is shown first, followed by extractions from the three system definitions in [“System A IMS system definition example”](#) on page 372, [“System B IMS system definition example”](#) on page 373, and [“System C IMS system definition example”](#) on page 374. These system definitions do not include Intersystem Communication (ISC).

MSC resources can be defined dynamically with CREATE MSPLINK, CREATE MSLINK, CREATE MSNAME, and CREATE LTERM commands.

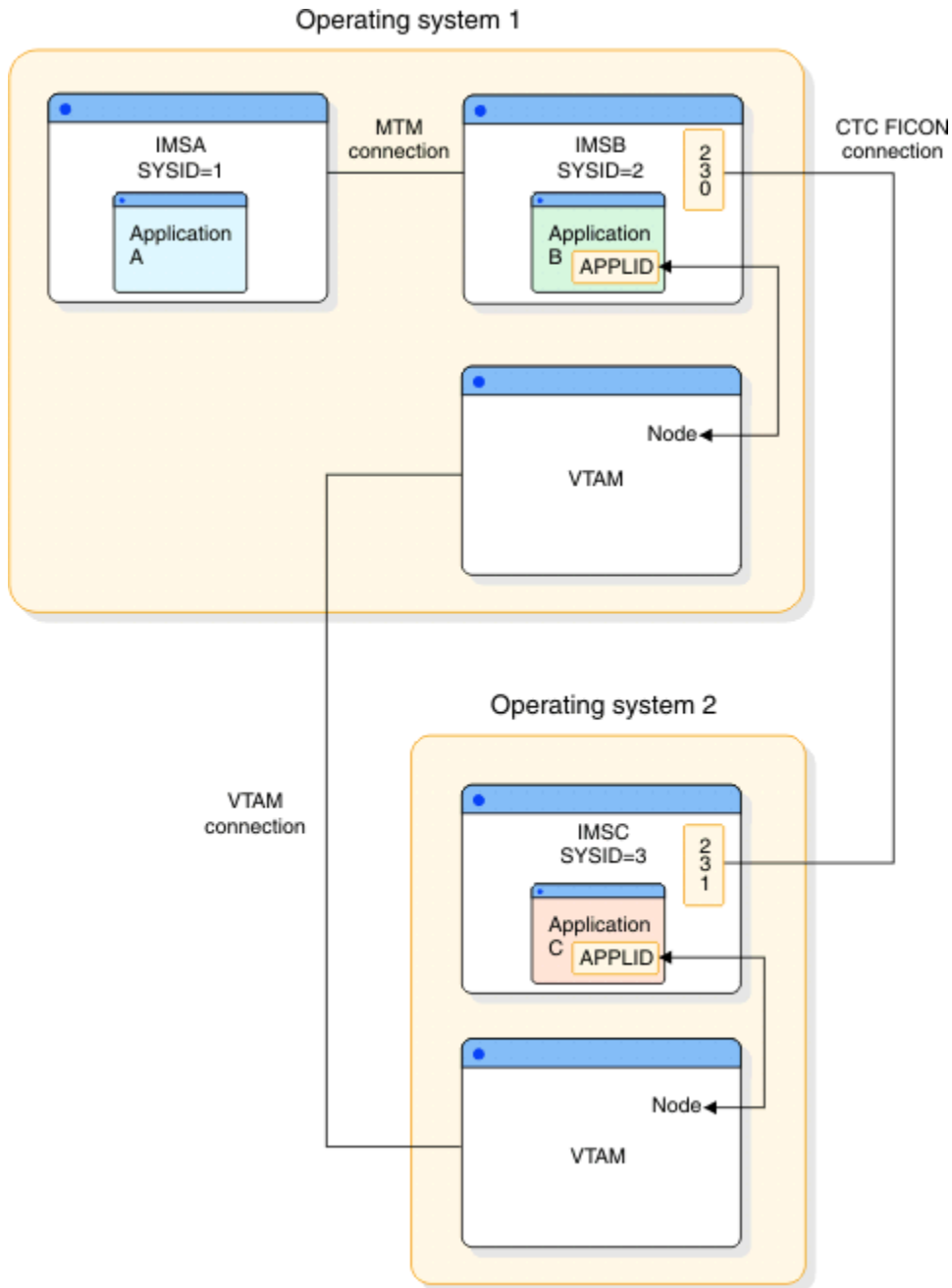

Figure 38. Multiple Systems Coupling example

System A IMS system definition example

Characteristics to define	Label	Macro statements prepared	Col. 72
IMS System Configuration		IMSCTRL MSVID=1, IMSID=SYSA	
Databases and Application Macros		DATABASE	
(Application programs that execute in other systems but process transactions)		APPLCTN TRANSACT APPLCTN PSB=A TRANSACT CODE=A APPLCTN PSB=B, SYSID=(2,1) TRANSACT CODE=B APPLCTN PSB=C, SYSID=(3,1) TRANSACT CODE=C	

```

entered by
System A
terminals are
defined as
remote.)

Data
Communication      COMM
                   TYPE
                   TERMINAL

(These logical
terminals are
defined in
Systems B and C
as remote
logical
terminals.)

Multiple Systems
Coupling           PLINK1  MSPLINK DDNAME=PLAB1,      X
                   ADDR=230,TYPE=CTC,      X
                   BUFSIZE=4096
                   PLINK2  MSPLINK TYPE=MTM,      X
                   BUFSIZE=4096
                   MSCLK1  MSLINK PARTNER=AB,      X
                   MSPLINK=PLINK1

                   END

```

```

(Terminals in
Systems B and C
that can enter
transaction
code A are
defined as
remote
terminals.)

MSC12  MSNAME SYSID=(2,1)
        NAME IMSBTRM1
        NAME IMSBTRM2
        NAME IMSBTRM3
MSC13  MSNAME SYSID=(3,1)
        NAME IMSCTRM1
        NAME IMSCTRM2
        NAME IMSCTRM3
        IMSGEN

```

System B IMS system definition example

Characteristics to define	Label	Macro statements prepared	Col. 72
IMS System Configuration		IMSCTRL MSVID=2,IMSID=SYSB	
Databases and Applications (Application programs that execute in other systems but process transactions entered by System B terminals are defined as remote.)		DATABASE APPLCTN TRANSACT APPLCTN PSB=B TRANSACT CODE=B APPLCTN PSB=A,SYSID=(1,2) TRANSACT CODE=A APPLCTN PSB=C,SYSID=(3,2) TRANSACT CODE=C APPLCTN TRANSACT	
Data Communication (These logical		COMM TYPE TERMINAL	

terminals are defined in Systems A and C as remote logical terminals.)

```

TYPE
TERMINAL
TYPE
TERMINAL
NAME IMSBTRM1
TERMINAL
NAME IMSBTRM2
TERMINAL
NAME IMSBTRM3
TERMINAL
NAME IMSVBT1
TERMINAL
NAME IMSVBT2
TERMINAL
NAME IMSVBT3
TERMINAL
NAME IMSVBT4

```

Multiple Systems Coupling

```

PLINK1 MSPLINK DDNAME=PLBA1, X
        ADDR=231,TYPE=CTC, X
        BUFSIZE=4096
PLINK2 MSPLINK TYPE=MTM, X
        BUFSIZE=1024
PLINK4 MSPLINK TYPE=VTAM, X
        NAME=SANFRAN, X
        SESSION=2, X
        BUFSIZE=8192

MSCLK2 MSLINK PARTNER=AB, X
        MSPLINK=PLINK1
MSC21 MSNAME SYSID=(1,2)
        NAME IMSATRM1
        NAME IMSATRM2
        NAME IMSATRM3

MSCLK3 MSLINK PARTNER=BC, X
        MSPLINK=PLINK2
MSC23 MSNAME SYSID=(3,2)
        NAME IMSCTRM1
        NAME IMSCTRM2
        NAME IMSCTRM3

MSCLK4 MSLINK PARTNER=CB, X
        MSPLINK=PLINK4
MSC24 MSNAME SYSID=(4,6)
        NAME IMSVCT1
        NAME IMSVCT2

MSCLK5 MSLINK PARTNER=CC, X
        MSPLINK=PLINK4, X
        OPTIONS=FORCSESS
MSC25 MSNAME SYSID=(5,7)
        NAME IMSVCT3
        NAME IMSVCT4

IMSGEN

END

```

System C IMS system definition example

Characteristics to define	Label	Macro statements prepared	Col. 72
IMS System Configuration		IMSCTRL MSVID=3,IMSID=SYSC	
Databases and Applications		DATABASE	
(Application programs that execute in other systems but process		APPLCTN TRANSACT APPLCTN PSB=C TRANSACT CODE=C APPLCTN PSB=A,SYSID=(1,3) TRANSACT CODE=A	

```

transactions
entered by
System C
terminals are
defined as
remote.)
APPLCTN PSB=B,SYSID=(2,3)
TRANSACT CODE=B
APPLCTN
TRANSACT

```

```

Data
Communication
COMM
TYPE
TERMINAL
(These logical
terminals are
defined in
Systems A and B
as remote
logical
terminals.)
TYPE
TERMINAL
NAME IMSCTRM1
TERMINAL
NAME IMSCTRM2
TERMINAL
NAME IMSCTRM3
TERMINAL
NAME IMSVCT1
TERMINAL
NAME IMSVCT2
TERMINAL
NAME IMSVCT3
TERMINAL
NAME IMSVCT4

```

```

Multiple
Systems
Coupling
PLINK1 MSPLINK DDNAME=PLCB1, X
ADDR=0BB,TYPE=BSC, X
BUFSIZE=4096,CONTROL=NO
PLINK4 MSPLINK TYPE=VTAM, X
NAME=SANJOSE, X
SESSION=2, X
BUFSIZE=8196
MSCLK6 MSLINK PARTNER=BC, X
MSLINK=PLINK1
MSC31 MSNAME SYSID=(1,3)
NAME IMSATRM1
NAME IMSATRM2
NAME IMSATRM3
MSC32 MSNAME SYSID=(2,3)
NAME IMSBTRM1
NAME IMSBTRM2
NAME IMSBTRM3
MSCLK7 MSLINK PARTNER=CB, X
MSLINK=PLINK4
MSC34 MSNAME SYSID=(6,4)
NAME IMSVBT1
NAME IMSVBT2
MSCLK8 MSLINK PARTNER=CC, X
MSLINK=PLINK4, X
OPTIONS=FORCSESS
MSC35 MSNAME SYSID=(7,5)
NAME IMSVBT3
NAME IMSVBT4
IMSGEN
END

```

Data-sharing system configuration

Four different system definition examples of IMS data-sharing systems are shown, including PSB definition statements.

These examples show four possible data-sharing system configurations. The IMS system definition macros that must be defined to support these configurations and the associated PSB definition statements are shown for each configuration. The illustrations in these examples assume that the database is registered with DBRC.

Data sharing at the database-level with update access

An example of data sharing at the database-level with update access, including IMS and PSB definition statements, is provided.

Figure 39 on page 376 shows a possible configuration for data sharing.

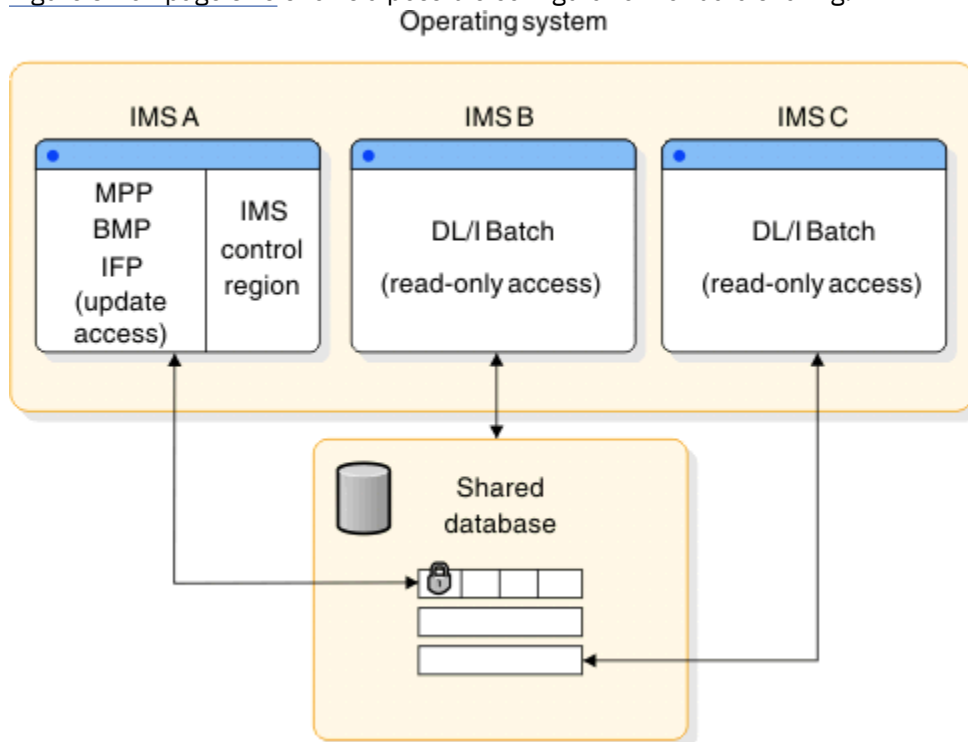

Figure 39. Data sharing at the database level with update access

System A

IMS system definition statements include:

```
IMSCTRL IMSID=IMSA  
DATABASE DBD=SHRDB,ACCESS=UP
```

PSB definition statements include:

```
PCB TYPE=DB,DBDNAME=SHRDB,PROCOPT=A
```

System B

IMS system definition statements include:

```
IMSCTRL IMSID=IMSB,SYSTEM=(VS2,BATCH)
```

PSB definition statements include:

```
PCB TYPE=DB,DBDNAME=SHRDB,PROCOPT=GO
```

System C

IMS system definition statements include:

```
IMSCTRL IMSID=IMSC,SYSTEM=(VS2,BATCH)
```

PSB definition statements include:

```
PCB TYPE=DB,DBDNAME=SHRDB,PROCOPT=GO
```

Data sharing at the database level with read access

An example of data sharing at the database level with read access, including IMS and PSB definition statements, is provided.

Figure 40 on page 377 shows a possible configuration for data sharing.

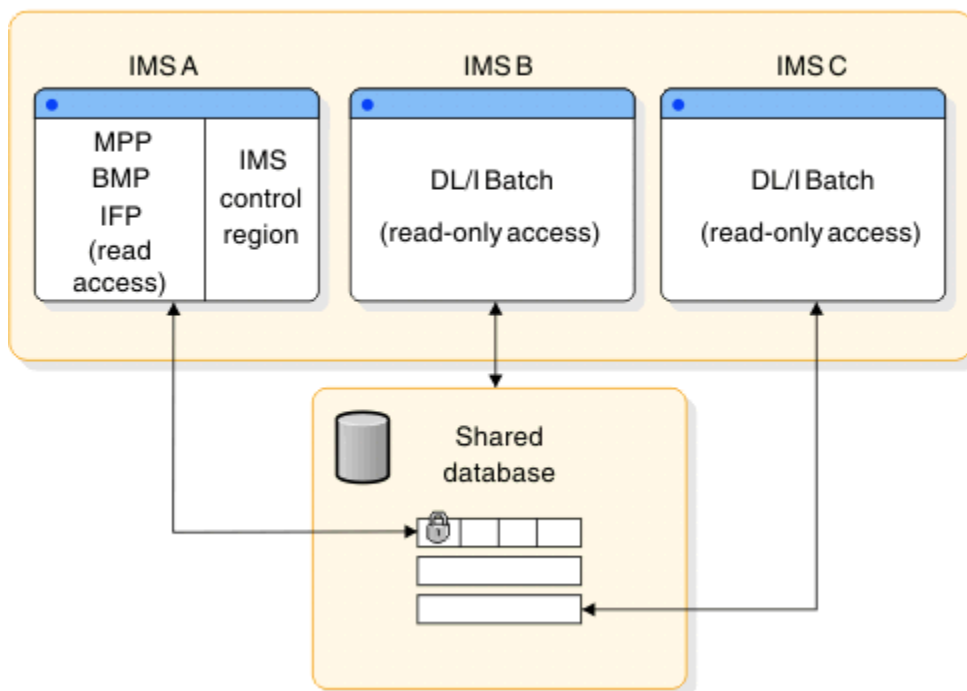

Figure 40. Data sharing at the database level with read access

System A

IMS system definition statements include:

```
IMSCTRL IMSID=IMSA  
DATABASE DBD=SHRDB,ACCESS=RD
```

PSB definition statements include:

```
PCB TYPE=DB,DBDNAME=SHRDB,PROCOPT=G
```

System B

IMS system definition statements include:

```
IMSCTRL IMSID=IMSB,SYSTEM=(VS2,BATCH)
```

PSB definition statements include:

```
PCB TYPE=DB,DBDNAME=SHRDB,PROCOPT=GO
```

System C

IMS system definition statements include:

```
IMSCTRL IMSID=IMSC,SYSTEM=(VS2,BATCH)
```

PSB definition statements include:

```
PCB TYPE=DB,DBDNAME=SHRDB,PROCOPT=G
```

Intra-CPC block-level data sharing

An example of intra-CPC block-level data sharing, including IMS and PSB definition statements, is provided.

Figure 41 on page 378 shows a possible configuration for data sharing.

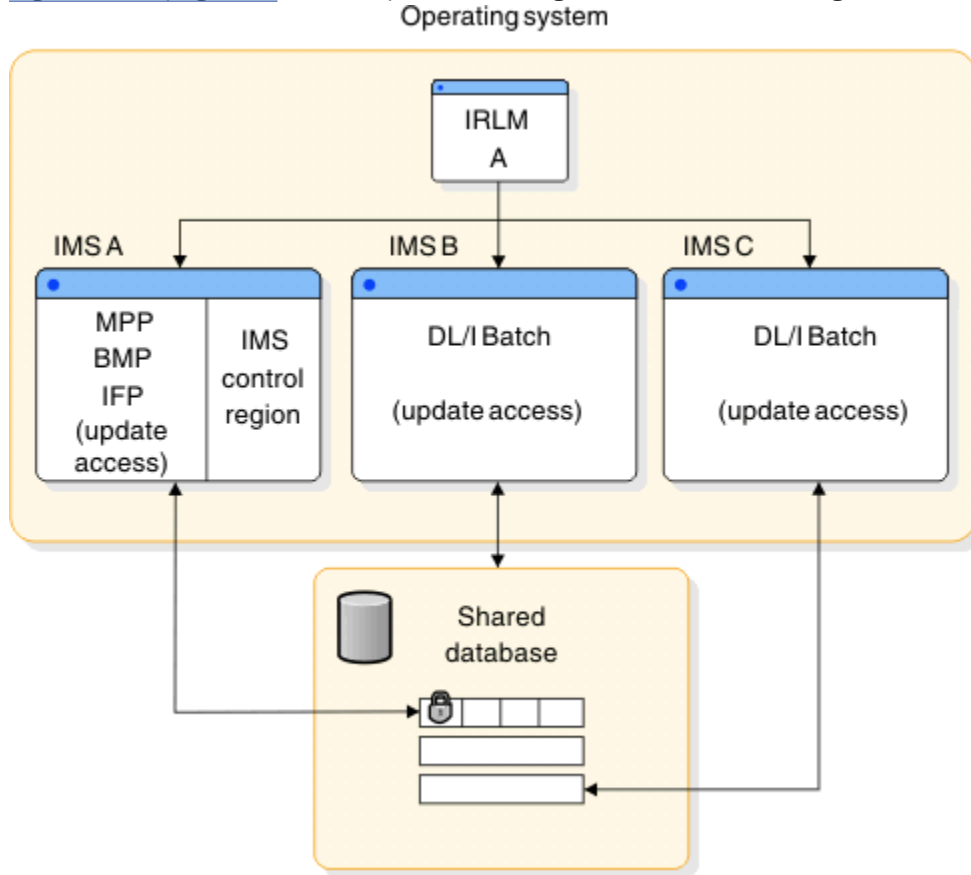

Figure 41. Intra-CPC block-level data sharing

System A

IMS system definition statements include:

```
IMSCTRL IMSID=IMSA, IRLMNM=RLMA  
DATABASE DBD=SHRDB, ACCESS=RD
```

PSB definition statements include:

- PCB TYPE=DB, DBDNAME=SHRDB, PROCOPT=A

System B

IMS system definition statements include:

```
IMSCTRL IMSID=IMSB, IRLMNM=RLMA, SYSTEM=(VS2, BATCH)
```

PSB definition statements include:

```
PCB TYPE=DB, DBDNAME=SHRDB, PROCOPT=GO
```

System C

IMS system definition statements include:

```
IMSCTRL IMSID=IMSC, SYSTEM=(VS2, BATCH)
```

PSB definition statements include:

PCB TYPE=DB, DBDNAME=SHRDB, PROCOPT=A

Inter-CPC block-level data sharing

An example of inter-CPC block-level data sharing, including IMS and PSB definition statements, is provided.

Figure 42 on page 379 shows a possible configuration for data sharing.

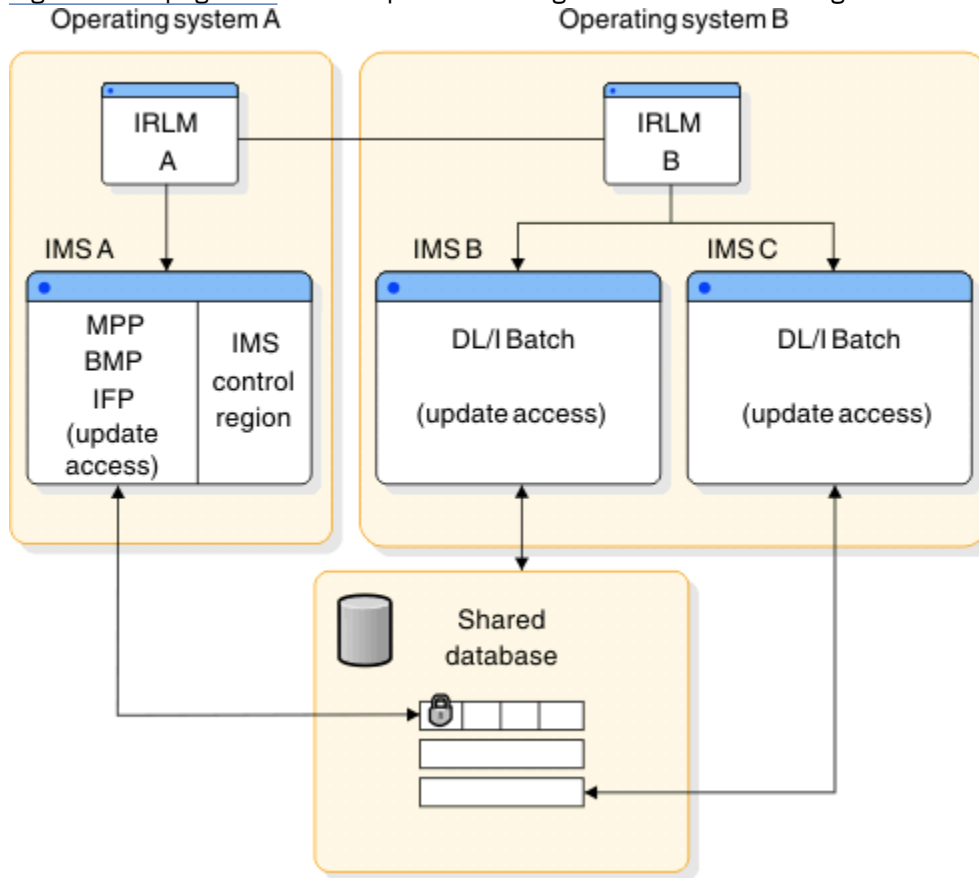

Figure 42. Inter-CPC block-level data sharing

System A

IMS system definition statements include:

```
IMSCTRL IMSID=IMSA, IRLMNM=RLMA
DATABASE DBD=SHRDB, ACCESS=UP
```

PSB definition statements include:

- PCB TYPE=DB, DBDNAME=SHRDB, PROCOPT=A

System B

IMS system definition statements include:

```
IMSCTRL IMSID=IMSB, IRLMNM=RLMB, SYSTEM=(VS2, BATCH)
DATABASE DBD=SHRDB, ACCESS=UP
```

PSB definition statements include:

```
PCB TYPE=DB, DBDNAME=SHRDB, PROCOPT=A
```

System C

IMS system definition statements include:

IMSCTRL IMSID=IMSC,IRLMNM=RLMB,SYSTEM=(VS2,BATCH)

PSB definition statements include:

```
PCB          TYPE=DB,DBDNAME=SHRDB,PROCOPT=APCB          TYPE=DB,DBDNAME=SHRDB,PROCOPT=A
```

IMS DBCTL environment

Sample stage 1 system definition input for an IMS DBCTL environment is provided in this topic.

Sample stage 1 input specifications for the DBCTL environment

The following shows sample stage 1 input specifications for the DBCTL environment:

```

                                                    Column
                                                    72
IMSCTRL SYSTEM=(VS/2,(ON-LINE,DBCTL),390),          X
      MAXREGN=(20,52K,A,A),                          X
      MCS=(2,7),DESC=7,MAXCLAS=1,IMSID=IMSA,         X
      CMDCHAR=4
*
* DEFINE FAST PATH OPTIONS (IGNORED BY IMS)
* FPCTRL OTHREAD=10,BFALLOC=(5,20,1024)
*
* DEFINE DL/I DATABASES
*
* DATABASE RESIDENT,DBD=DI21PART
*
* DEFINE SAMPLE APPLICATIONS
*
* APPLCTN PSB=DFHSAM04,SCHDTYP=PARALLEL
* APPLCTN PSB=DFHSAM05,SCHDTYP=PARALLEL
*
IMSGEN ASM=(HLASM,SYSLIN),                            X
      ASPRT=ON,                                        X
      LKPRT=(XREF,LIST),                              X
      LKSIZE=(880K,64K),                              X
      LKRGN=4096K,                                    X
      SUFFIX=1,                                        X
      SURVEY=NO,                                       X
      SYMSMG=TIMESTAMP,                               X
      OBJDSET=IMS.OBJDSET,                             X
      NODE=(IMS,IMS,IMS),                             X
      JCL=(GENJOB,                                     X
      (1),                                           X
      PGMERID,                                       X
      A,                                             X
      (TIME=5,CLASS=K,NOTIFY=PGMERID)),              X
      SCL=(99)
END
```

Chapter 17. IMS Syntax Checker

The Syntax Checker is an ISPF application that helps you define, verify, and validate parameters and their values in the members of the IMS PROCLIB data set. Use the IMS Syntax Checker to avoid typographical and syntactical errors when modifying the parameter values for the IMS PROCLIB data set members.



Attention: The IMS Syntax Checker is stabilized. IBM will no longer invest in enhancing this feature and intends to remove the feature from all future product releases. Please refer to the [IMS 15.2 announce letter](#).

The Syntax Checker:

- Reads in the IMS PROCLIB data set member.
- Displays the parameters and values.
- Allows modification of the parameter values.
- Helps migrate supported IMS PROCLIB data set members from one version of IMS to another.
- Displays default values for parameters.
- Verifies the validity of parameters and values.
- Saves changes back to the IMS PROCLIB data set member.

The Syntax Checker supports all members of the IMS PROCLIB data set, with the exception of FRPCFG, which is not supported in IMS Version 11, and DFSVSMxx.

The Syntax Checker provides an ISPF panel where you can add or change parameter values in the members. Online help is available at the parameter level and provides assistance in moving to a new IMS release by identifying new parameters as well as any obsolete parameters from the previous release.

The Syntax Checker checks parameters for valid values and accepts only valid values. It saves the parameters to appropriate members of the IMS PROCLIB data set in the correct format. The next time the control region is started, it will use the new values.

Requirement: The IMS control region must be restarted to activate the new parameter values.

The IMS IVP contains a Syntax Checker sample application that demonstrates how to use the IMS Syntax Checker. It demonstrates how to migrate a DFSPBxxx member of the IMS PROCLIB data set from an earlier version of IMS to a later version.

Recommendations:

- The IMS Syntax Checker does not perform security checking or bypass system security. You should protect your IMS data sets from unauthorized access by using RACF or an equivalent security product.
- To avoid unpredictable results with the Syntax Checker, use a screen size of 43 X 80.

Related concepts

[IMS installation verification program \(IVP\) overview \(Installation\)](#)

[“Controlling the IMS PROCLIB data set” on page 201](#)

Carefully examine the procedures generated during SMP/E processing.

Related reference

[“The specification of IMS procedures” on page 517](#)

When you specify IMS.SDFSRESL procedures, you must consider where they are stored, whether they need to load the IMS SVC modules, and which IMS environments support the procedures.

Function keys and the Syntax Checker

Under ISPF, use the FKA ON command to display function keys, and use the KEYS command to set function keys.

The Syntax Checker panels and Help panels have function keys assigned through an ISPF keylist. Although ISPF allows you to turn off the use of keylists, you should leave keylists on if you use the Help panels. Some function keys continue to be active, but are not shown when FKA ON is used. [Table 46 on page 382](#) describes the function keys used for the Syntax Checker.

Table 46. Syntax Checker function key descriptions

Key	Description
F1=Help	Display Help information for panels and keywords.
F2=Split	ISPF split screen.
F3=Exit	Exit the current function. Returns back to the previous panel. If modifications have been made to the current member, the user is prompted to SAVE the member before returning back to the previous panel.
F6=Defaults	Display default values for keywords.
F7=Backward	Scroll backward. Pages backward through the list of parameters when the complete list of parameters cannot be displayed on one screen.
F8=Forward	Scroll forward. Pages forward through the list of parameters when the complete list of parameters cannot be displayed on one screen.
F9=Swap	ISPF swap screen command.
F10= Edit	Move cursor to Edit action bar.
F12=Cancel	Cancel action and return to previous panel.

Starting the Syntax Checker

You can start the IMS Syntax Checker using an EXEC command or from the IMS Application Menu.

Start the Syntax Checker by issuing the following command in ISPF option 6:

```
EXEC 'HLQ.SDFSEXEC(DFSSCSRT)' 'h1q(HLQ)'
```

You can also start the Syntax Checker from the IMS Application Menu. The IMS Application Menu provides a common interface to IBM-supplied IMS applications that run on TSO and ISPF. The Syntax Checker remains running until you exit it manually.

Related Reading: For more information about the IMS Application Menu, see *IMS Version 15.4 Installation*.

Syntax Checker online help

Help for the IMS Syntax Checker is available by pressing the Help key (typically the F1 key) or using the help pull-down menu whenever you are using the Syntax Checker.

Help is available by pressing the Help key (typically the F1 key) or using the help pull-down menu whenever you are using the Syntax Checker.

- For any panel: Press the Help key to display a description of the panel.

- For the Syntax Checker Keyword Display Panel: To get specific keyword help, position the cursor anywhere on the keyword line and press the Help key.

Help information is provided in a scrollable panel. The help information describes the Syntax Checker panel or selected keyword parameter.

Using the Syntax Checker

On the main panel of the IMS Syntax Checker, you can enter the IMS PROCLIB data set name and the name of the member to be processed.

After you start the Syntax Checker, the main panel (Syntax Checker Member and Data Set Name panel) shown in [Figure 43 on page 383](#) is displayed.

Important: The panels shown in this document are samples and, as such, might not completely match the actual panels that appear on your screen. The purpose of the panels here is to help guide your use of the Syntax Checker.

```

File  Help
-----
                    IMS Parameter Syntax Checker
Command ==>>>

Enter the name of the IMS proclib dataset and press enter.

ISPF Library:
Project . . . -----
Group . . . -----
Type . . . -----
Member . . . ----- (Blank for member list)

Other Partitioned Data Set: 'IMS
Data Set Name . . 'HLQ.PROCLIB(DFSPBSYN)'
Volume Serial . . (If not cataloged)

```

Figure 43. Syntax Checker Member and Data Set Name panel

You use the Syntax Checker Member and Data Set Name panel to enter the IMS PROCLIB data set name and the name of the member to be processed. To enter the names, use the standard TSO and ISPF formats:

- Enter the data set and member names using the ISPF Library: Project, Group, Type, and Member fields.
- Enter the data set and member name using the *Other Partitioned Data Set: Data Set Name* field.

If you do not enter the member name, a member list is displayed. Select the member you want to process from the list.

If the data set is not cataloged, enter the data set's volume in the Volume Serial field.

In this example, the IMS PROCLIB data set name HLQ.PROCLIB (where HLQ is the high-level qualifier) and the member name DFSPBSYN are entered.

When you press **Enter** from the main panel, the Syntax Checker reads the input file and tries to determine the IMS release and type of control region. If the Syntax Checker cannot determine this information, one of the following panels displays:

- IMS Release and Control Region panel shown in [Figure 44 on page 384](#).
- IMS Release panel shown in [Figure 45 on page 385](#).

If the Syntax Checker is able to determine the information it requires from comments in the member, then the Syntax Checker Keyword Display panel shown in [Figure 46 on page 385](#) displays.

IMS Release and Control Region panel

The IMS Release and Control Region panel provides the Syntax Checker with IMS release and control region information that is required to process the member correctly.

An example of the IMS Release and Control Region panel is shown in the following figure.

```
File Help
-----
                                IMS Parameter Syntax Checker
Command ==>

Enter the following information and press enter.

IMS Release . . . . . 1 1. IMS 12.1
                               2. IMS 11.1
                               3. IMS 10.1

Type of Control Region . . . 3 1. DBCTL Control Region
                                   2. DCCTL Control Region
                                   3. DB/DC Control Region
                                   4. FDBR Region
                                   5. DLI/DBB Batch
```

Figure 44. IMS Release and Control Region panel

When the Syntax Checker saves the member, it adds comment lines to the top of the member saving this information. The next time the Syntax Checker processes the member, this panel does not display.

The input fields for the IMS Release and Control Region panel include:

Field

Description

IMS Release

Enter 1, 2, or 3 to specify the IMS release.

This is a required field.

Type of Control Region

Enter 1, 2, 3, 4, or 5 to specify the type of control region.

This is a required field.

After you type in the data and press **Enter**, the Syntax Checker Keyword Display panel is displayed.

[“Keyword Display panel” on page 385](#) shows the parameters that are currently specified for the member provided.

Related reference

[“Syntax Checker online help” on page 382](#)

Help for the IMS Syntax Checker is available by pressing the Help key (typically the F1 key) or using the help pull-down menu whenever you are using the Syntax Checker.

IMS Release panel

The IMS Release panel provides the Syntax Checker with IMS release information that is required to process the member correctly.

The IMS Release panel is shown in the following figure.

```

File  Help
-----
                    IMS Syntax Checker
Command ==>>

Enter the following information and press enter.

IMS Release . . . . . 1. IMS 12.1
                   2. IMS 11.1
                   3. IMS 10.1

```

Figure 45. IMS Release panel

Enter 1, 2, or 3 to specify the correct IMS release information. This is a required field.

After you type in the data and press **Enter**, the Syntax Checker Keyword Display panel is displayed. “Keyword Display panel” on page 385 shows the parameters that are currently specified for the member.

Related reference

“Syntax Checker online help” on page 382

Help for the IMS Syntax Checker is available by pressing the Help key (typically the F1 key) or using the help pull-down menu whenever you are using the Syntax Checker.

Keyword Display panel

The Keyword Display panel of the IMS Syntax Checker displays the keywords and their values and indicates whether syntax errors exist.

The Keyword Display panel, shown in the following figure, is the main working panel. It displays the keywords and their values and indicates any errors.

```

File  Edit  View  Help
-----
                    IMS 12.1 Parameters for DB/DC
Command ==>>
Member DFSPBSYN processed under IMS 12.1 (DB/DC )
Press enter (without other input) to check for errors.

Data Set Name . . . : HLQ.PROCLIB(DFSPBSYN)
IMS Release . . . : 12.1

Sel Codes: C = Comment D = Delete I = Insert P = Process / = Select

Sel Keyword      Value      Description
- ALOT           = 9         ETO Auto Logon Off Time
- AOIS           = A         ICMC Security Option
- APPC           = Y         Activate APPC/IMS (Y|N)
- APPLID2        = IMS2      VTAM Applid of XRF Alternate System
- ARC            = 99        Automatic Archive: 1-99, 0 - NOT Autom.
- ASOT           = 1000      ETO Auto Signoff Time
- AUTO           = Y         Automatic Restart Desired (Y|N)
- CHTS           = 1000      Obsolete keyword
- CMDMCS         = N         MCS/EMCS Command Option
- DBBF           = 1000      Number of Database Buffers
- DBFX           = 10        Num. DB Buffs available at FP Reg Start
- DBRCNM        = DBCPROC    DBRC Proclib Member Name

```

Figure 46. Keyword Display panel

Related reference

“Syntax Checker online help” on page 382

Help for the IMS Syntax Checker is available by pressing the Help key (typically the F1 key) or using the help pull-down menu whenever you are using the Syntax Checker.

Display options for the Keyword Display panel

The Syntax Checker provides several display options that you can select from the View pull-down menu.

The following are the options:

Select Display

Display all keywords with values. These keywords are saved when the member is saved.

All Display

Display all possible keywords. Only keywords with values are saved when the member is saved.

New Display

Display all new keywords in this release of IMS. These keywords are saved only if they have values when the member is saved.

The status of the member determines whether keywords are displayed the first time the panel is displayed:

- If the member is new or empty, a list of all possible keywords for the member is displayed (All Display). The list of keywords is shown in alphabetic order.
- If the member is not empty or new, the list contains the current keywords defined in the member (Select Display). The list is shown in custom order. You can obtain a display of all possible keywords for the member by using the View pull-down Display All option. The customer order display and save feature will be delivered through the IMS service process.

To display the default values for parameters, press the F6 function key to toggle between displaying and not displaying defaults. The default values are displayed in the description field of the parameter. When default values are displayed, the description or comment appears to the right of the field. Shifting the display to the right or left is not supported.

Panel field descriptions for the Keyword Display panel

Help information for the IMS Syntax Checker is provided. This topic describes the fields on the Keyword Display panel.

Field**Description****Panel Title**

The IMS release and control region.

Data Set Name

The IMS PROCLIB data set and member name.

IMS Release

The release of the IMS system to which the parameters apply.

Sel

An input field that allows you to:

- Select with an I to insert a keyword. The insert panel pops up.
- Select with a C to process the keyword using the Comments command.
- Select with a D to process the keyword using the Delete command.
- Select with a P to interrupt the processing of the current member and begin processing the member identified by the selected parameter. For more information about this option, see [“Interrupting processing to process other members on the Keyword Display panel”](#) on page 390.
- Select with a / (slash) to process the keyword using the Action pull-down option.
- Select with a + (plus) displays the keyword on multiple lines. When a keyword is expanded, the subparameters are displayed in a predefined order.
- Select with a - (minus) displays the keywords on one line. As much of the keyword as fits on one line is displayed followed by "...".

Keyword

The name of the keyword.

The keywords are color-highlighted as follows:

Green

Normal color for a keyword with a value.

Blue

A new keyword in this release.

Yellow

Warning: Read the help text.

Red

Keyword Error

Turquoise

Keyword is a template. The keyword has no value and is not saved. These keywords are only displayed in the DISPLAY ALL panel.

Value

The modifiable field which contains the value assigned to the keyword parameter. You can position the cursor on the input field and press the help key to get more information about the keyword parameter.

The keywords are color-highlighted as follows:

Turquoise

Value is correct.

Red

Value error.

Description/Comment

Provides a short description of the keyword parameter or a user-provided comment. You can modify both the description and the comment. A modified description becomes a user comment. If the user comment is set to all blanks, the description is displayed. The user comment is written to the member when the member is saved, but the description provided by the Syntax Checker is not.

The user-provided comment can be a maximum of 42 characters, but sometimes it is much shorter than 42 characters because the keyword and values take more spaces than usual. Therefore, the maximum characters the user can provide depends upon the keyword. Comments are not supported by all members. See [“Specifying comments in IMS PROCLIB data set members processed by the Syntax Checker” on page 388](#) for information about specific members that support comments.

Note: For the DFSPBxxx members, an equal sign (=) is not allowed in a user-provided comment. If an equal sign is found in a user-provided comment, the Syntax Checker changes it to a dash (-) and displays message DFISI937I Equal sign in same line comment changed to dash.

Syntax Checker error checking

After modifying the member, press the **Enter** key without making any other modifications. Syntax value checking is performed.

If there are errors, the first keyword with an error moves to the top of the display and an error message is displayed. The error must be corrected before the next error can be displayed.

For example, in [Figure 46 on page 385](#), the Syntax Checker Keyword panel contains deliberate errors labeled as Unknown Keywords. On the screen, each error shows up in red on the screen and is displayed at the top of the list of keywords.

The first error (APPLID=IMS1) is a typographical error. Adding a 1 to the end of APPLID makes it a valid parameter (APPLID1).

The second error (Keyword XXXXX) is not a valid keyword. To resolve this error, delete the keyword. In this example, a "D" (delete) select code is typed into the Sel field next to the XXXXX.

The third error is that the AUTO parameter has an erroneous value of X instead of a correct value of Y or N. If you press the **Enter** key with no other input, the AUTO parameter is displayed on the top line of the display and an error message describing the error is displayed.

When all errors are resolved and you have modified the member as required, you can save the member to the originally selected PROCLIB and member or to a different PROCLIB and member.

Specifying comments in IMS PROCLIB data set members processed by the Syntax Checker

IMS allows comments to be included in most IMS PROCLIB data set members. Special considerations exist for comments in IMS PROCLIB data set members processed by the Syntax Checker.

IMS allows comments to be included in most IMS PROCLIB data set members. The comments can be either full-line comments or comments that appear on the same line as the parameters. The style of comment depends upon the specific member being processed.

In general, full-line comments are indicated by an asterisk (*) or a slash-asterisk (/*) in column 1. Each comment is associated with the parameter keyword that follows the comment. When the file is written, the comments precede the keyword. You can add, edit, or delete comments in the following ways:

- Use the select option, C, to select the keyword associated with, or to be associated with, the comment. Press **Enter**.

The panel redisplay with a blank comment line above the selected keyword. Add your comment to the blank line.

- The comment can be modified at any time.
- To delete a comment, enter the select option, D, next to the comment line. Press **Enter**.

The following table describes considerations for specifying comments for specific members.

Table 47. Special considerations for comments in IMS PROCLIB data set members processed by the Syntax Checker

Members	Considerations when specifying comments
<ul style="list-style-type: none"> • BPE exit list member • CQSIPxxx • CQSSGxxx • CQSSLxxx • CSLDCxxx • CSLDIxxx • CSLOIxxx • CSLRIxxx • CSLSIxxx • DFSCGxxx • DFSDFxxx • DFSPBxxx • DSPBIxxx • FRPCFG • HWSCFGxx 	Comments can be specified on a separate line, or they can be specified on the same line as parameters. A comment is separated from the parameter by one or more blanks. Comments can contain any characters except the equal sign (=).
DFSDCxxx	Comments must be specified on a separate line; comments are not allowed on the same line as parameters. You cannot edit the description of the parameter.
DFSSQxxx	Comments are supported in IMS Version 10 and later.

Action pull-down options on the Keyword Display panel

Use the action pull-down options on the Keyword Display panel to select which file, edit, and view action to take.

Action pull-down options are located at the top of the panel. Selecting an Action pull-down option displays the options available for the action pull-down.

File action options:

Save

The keywords are stored back into the originally selected PROCLIB member. You can save the keywords in alphabetical or custom order. The feature to display and save parameters in custom order-of-input will be delivered through the IMS service process.

Save As

The keywords are stored in a specific data set and member. You can save the keywords in alphabetical or custom order. The feature to display and save parameters in custom order-of-input will be delivered through the IMS service process.

Change Release

This option changes the IMS release of the parameter member being processed as follows:

1. If any changes have been made to the current member, you are given an option to save the member before changing the release.
2. The member is reprocessed under the new release, identifying any value errors and invalid or obsolete keywords.

Edit action options:

Comments

Adds a comment to keywords that have been selected with the / operand.

Delete

Deletes from the display keywords that have been selected with the / operand.

Delete All

Deletes the ALL keywords from the display.

View action options

Display All

Changes the keyword display to include all possible keywords for the selected IMS release and control region type. These keywords are saved only if they have values when the member is saved.

Display Selected

Changes the keyword display to include only the keywords that have a value. This is the list of parameters that are saved when the save command is issued.

Display New

Changes the keyword display to include only the keywords that are new for the IMS release. These keywords are saved only if they have values when the member is saved.

+ (expand)

Displays the keyword on multiple lines. When a keyword is expanded, the subparameters are displayed in a predefined order.

- (contract)

Displays the keywords on one line. As much of the keyword as fits on one line is displayed followed by "...".

Alphabetical Order

Specifies that the keywords are shown in alphabetical order, sorted by keyword name.

Custom Order

Specifies that the keywords are displayed in custom order.

The type and status of the member determines whether keywords are displayed the first time the panel is displayed:

- If the member is order-dependent, the list of keywords is displayed according to the predefined order.
- If the member is new or empty, a list of all possible keywords for the member is displayed (**Display All**). The list of keywords is shown in alphabetical order, unless the member is order-dependent.
- If the member is not empty or new, the list contains the current keywords defined in the member (**Display Selected**). The list is shown in custom order. You can obtain a display of all possible keywords for the member by using the View pull-down **Display All** option.

To display the default values for parameters, press the F6 function key to toggle between displaying and not displaying defaults. The default values are displayed in the description field of the parameter. When default values are displayed, the description or comment appears to the right of the field. Shifting the display to the right or left is not supported.

Related concepts

[“Saving processed members on the Keyword Display panel” on page 391](#)

While using the Keyword Display Panel, the processed member can be saved to the originally selected PROCLIB and member or to a different PROCLIB and member.

Inserting keywords into the Keyword Display panel

To insert a keyword into the display, type an "I" (insert) in the Sel field and press **Enter**. A pop-up window that lists the possible items that can be inserted appears.

New keywords are added in alphabetic order. See the following figure for an example of the insert pop-up window.

```
File Edit View Help
-----
S
C          Insert keyword
P Select your keyword and press Enter.
D          1. RSRCSTRUCTURE
I          2. STRUCTURE
-----
rs.

= Select

ion
g stream name
of a data object
or overflow processing
for overflow processing
, Dataset name
, Dataset name
ry structure size
o which CQS connects
```

Figure 47. Example of insert pop-up window for Syntax Checker Keyword Display panel

Interrupting processing to process other members on the Keyword Display panel

While using the Keyword Display Panel, you can select the P option to interrupt processing of the current member and begin processing another member.

The P option is valid on any keyword whose value is used to identify a member in the IMS PROCLIB data set. The keyword displays as underlined for easy identification. The keyword must have a value.

The selected member is processed under the current IMS release. When processing of the selected member is complete (F3), processing of the interrupted member returns.

If the member does not exist, the panel shown in [Figure 48 on page 391](#) is displayed to ask if a new member should be created or if the member should be processed in a different data set. If neither action is appropriate, the user can choose to cancel processing of the member.

```
IMS Syntax Checker
Command ===>

The Member DFSDC001 does not exist in dataset 'xxx.yyy.zzz'
Select one of the following options:

Option: __
1. Create a new member in current dataset
2. Cancel processing of the member
3. Process member in different dataset:
----- (Dataset name)
```

Figure 48. Member Does Not Exist panel

If the member is not one of the members processed by Syntax Checker, the panel shown in [Figure 49 on page 391](#) is displayed to ask if the user wants to edit or create the member in the current data set, edit or create the member in a different data set, or cancel processing of the member.

```
IMS Syntax Checker
Command ===>

The Member DFSDC001 is not processed by Syntax Checker.
Select one of the following options:

Option: __
1. Edit/Create member in current dataset
2. Cancel processing of the member
3. Edit/Create member in different dataset:
----- (Dataset name)
```

Figure 49. Member is Not Processed by Syntax Checker panel

Saving processed members on the Keyword Display panel

While using the Keyword Display Panel, the processed member can be saved to the originally selected PROCLIB and member or to a different PROCLIB and member.

To save the member, you use one of the Save or Save As options. The parameters are stored in the PROCLIB member as follows:

- The parameters are stored in alphabetical or custom order. The feature to display and save parameters in custom order-of-input will be delivered through the IMS service process.
- Only the parameters that are displayed in the Display Selected keyword panel are stored. These parameters are either read in from the member or assigned a value during Syntax Checker processing of the member.
- For members that support comments:
 - Comments are stored in front of their keyword. Syntax Checker also supports same-line comments. Same-line comments are stored on the same line as the keyword.
 - Syntax Checker adds the following informational comments to the top of the member:

```
IMS Version:          *<version> 12.1
Last Modified date:   *<date> 2011/09/25
Last Modified time:   *<time> 15:34
Modifying userid:     *<sysuid> GR80NE
```

Related concepts

[“Save Member prompt panel” on page 392](#)

On the Save Member prompt panel of the IMS Syntax Checker, you are notified of any problems before the Syntax Checker saves the member, and you can either save or not save the member.

Related reference

[“Action pull-down options on the Keyword Display panel” on page 389](#)

Use the action pull-down options on the Keyword Display panel to select which file, edit, and view action to take.

Save Member prompt panel

On the Save Member prompt panel of the IMS Syntax Checker, you are notified of any problems before the Syntax Checker saves the member, and you can either save or not save the member.

The Save Member Prompt panel shown in [Figure 50 on page 392](#), notifies you of an issue or problem before the Syntax Checker saves the member or continues without saving the member. You are prompted to SAVE or NOT SAVE the member currently being processed.

```
File Edit View Help
+-----+
|           IMS Parameter Syntax Checker           |
| Command ==>                                     |
|                                                 |
| Member DFSPBSYN has been modified.             |
| Do you wish to save it?                         |
|                                                 |
| Save Member ? . . . . . 2 1. YES                |
|                                     2. NO        |
+-----+
- APPLID2 = IMS2          VTAM Applid of XRF Alternate System
- ARC      = 99           Automatic Archive: 1-99, 0 - NOT Autom.
- ASOT     = 1000         ETO Auto Signoff Time
- AUTO     = Y            Automatic Restart Desired (Y|N)
- CHTS     = 1000         Number of CCB Hash Table Slots
- CMDMCS   = N            MCS/EMCS Command Option: N|Y|R|C|B
- DBBF     = 1000         Number of Database Buffers
- DBFX     = 10           Num. DB Buffs available at FP Reg Start
- DBRCNM   = DBCPROC     DBRC Problib Member Name
```

Figure 50. Save Member Prompt panel

The input field for this panel includes:

Save Member?

- Enter 1 to save the member.
- Enter 2 to continue without saving the member.

The **Save Member** field is a required field.

Related concepts

[“Saving processed members on the Keyword Display panel” on page 391](#)

While using the Keyword Display Panel, the processed member can be saved to the originally selected PROCLIB and member or to a different PROCLIB and member.

SAVE AS prompt panel

On the SAVE AS prompt panel, you specify the data set name and the member name in which to save the current keywords being processed.

The SAVE AS Prompt panel, shown in [Figure 51 on page 393](#) provides the Syntax Checker with the data set name and the member name in which to save the current keywords being processed. Enter the data set name and member name in the standard TSO and ISPF formats.

```

File  Help
-----
                                Save IMS Parameter
Command ==>

Enter the "SAVE AS" dataset and member name then press enter.

Current Data Set:
  Data Set Name : HLQ.PROCLIB(DFSPBSYN)
  Volume Serial :

SAVE AS Data set and Member:

ISPF Library:
  Project . . -----
  Group . . . -----
  Type . . . . -----
  Member . . .

Other Partitioned Data Set:
  Data Set Name . . 'HLQ.PROCLIB(DFSPB888) '
  Volume Serial . .

```

Figure 51. SAVE AS Prompt panel

- Enter the data set and member names using the ISPF Library: Project, Group, Type, and Member fields.
- Enter the data set and member names using the Other Partitioned Data Set: Data Set Name field.

If the data set is not cataloged, enter the data set's volume in the Volume Serial field.

For more information about how parameters and comments are stored when you save a member, see [“Saving processed members on the Keyword Display panel” on page 391.](#)

IMS Parameter Syntax Checker panel

On the IMS Parameter Syntax Checker panel in the IMS Syntax Checker, you select which release of IMS the Syntax Checker should use.

On the IMS Parameter Syntax Checker panel, shown in the following figure, you can select which release of IMS the Syntax Checker uses to process the keywords.

The Change Release option can be found on the File pull-down menu.

Keywords are processed again under the new release to identify any value errors and invalid or obsolete keywords.

The input field for this panel includes:

IMS Release

Enter 1, 2, or 3 to specify the IMS release.

This is a required field.

```
+-----+
|      IMS Parameter Syntax Checker      |
| Command ==>                          |
|                                         |
| Enter the following information and press enter. |
|                                         |
| |                                       |
| IMS Release . . . . . 1. IMS 12.1      |
|                               2. IMS 11.1 |
|                               3. IMS 10.1 |
|                                         |
| Type of Control Region . . . 1. DBCTL Control Region |
|                               2. DCCTL Control Region |
|                               3. DB/DC Control Region |
|                               4. FDBR Region          |
|                               5. DLI/DBB Batch       |
+-----+
```

Figure 52. IMS Parameter Syntax Checker panel

Related reference

[“Syntax Checker online help” on page 382](#)

Help for the IMS Syntax Checker is available by pressing the Help key (typically the F1 key) or using the help pull-down menu whenever you are using the Syntax Checker.

Chapter 18. Macros used in IMS environments

These topics provide general information about using IMS macros.

Related reference

[“Selecting the appropriate macros to define your system” on page 5](#)

When you choose to define or modify an IMS system, the system definition parameters that you can define or modify vary by the type of system definition. Certain macro statements, keywords, and parameters require additional consideration if you are newly adding or entirely deleting them from the system.

Reference information for using IMS macros

Use IMS macro statements to generate a sequence of assembler statements from a single source statement. IMS provides a set of macro statements for system definition.

For example, to describe program resource requirements for your application programs, use the APPLCTN macro. To define characteristics of VTAM nodes and non VTAM communication, use the TERMINAL macro.

The APPLCTN, DATABASE, RTCODE, and TRANSACT macros are used to define application programs, databases, Fast Path route codes, and transactions. These IMS resources can be changed, added, and deleted by using either dynamic resource definition (DRD) or online change. The online change process requires that some system definition tasks be performed offline. The DRD process, which uses CREATE, DELETE, and UPDATE commands to define these resources, does not require any offline tasks. When DRD is enabled (by specifying MODBLKS=DYN in the DFSCGxxx PROCLIB member), online change for resources in the IMS.MODBLKS data set, but not for other resources, is disabled. Likewise, when DRD is disabled (MODBLKS=OLC in the DFSCGxxx PROCLIB member), commands that are used for DRD, except for some types of the UPDATE command, are not supported. The UPDATE commands that change status or runtime values are supported.

System definition macros and their uses

The following table contains a list of IMS system definition macros. [“Selecting the appropriate macros to define your system” on page 5](#) describes which macros and macro keywords can be modified by which type of system definition.

Type of macro statement	Macro name	Resources each macro defines
System configuration macros	“FPCTRL macro” on page 427	Fast Path options
	“IMSCTRL macro” on page 427	Library naming, JCL options, and ETO feature
	“IMSGEN macro” on page 437	z/OS system and control options
	“MSGQUEUE macro” on page 453	Message queue device and message sizes

Table 48. System definition macros and their uses (continued)

Type of macro statement	Macro name	Resources each macro defines
Database and application macros	“APPLCTN macro” on page 400	Program characteristics and PSB names
	“DATABASE macro” on page 415	DBD names
	“RTCODE macro” on page 469	Fast Path message routing
	“TRANSACT macro” on page 498	Transaction processing options

Table 48. System definition macros and their uses (continued)

Type of macro statement		Macro name	Resources each macro defines
Data communication macros	Non-VTAM device ¹	“COMM macro” on page 407	General communication options
		“LINE macro” on page 448	Communication line to IMS
		“LINEGRP macro” on page 450	DD names for communication devices
		“NAME macro” on page 465	LTERM definition
		“TERMINAL macro” on page 471	Physical characteristics of terminal
	Multiple System Coupling	“MSLINK macro” on page 457	Logical Link names
		“MSNAME macro” on page 460	Partner systems
		“MSPLINK macro” on page 461	Physical link names
		“NAME macro” on page 465	LTERM definition
	VTAM	“COMM macro” on page 407	General communication options
		“NAME macro” on page 465	LTERM definition
		“SUBPOOL macro” on page 470	Set of LTERMs for a static ISC session
		“TERMINAL macro” on page 471	Physical characteristics of a static terminal
		“TYPE macro” on page 514	VTAM terminal type
“VTAMPOOL macro” on page 516		Multiple systems with ISC sessions	

¹ See the LINEGRP UNITYPE= keyword for detailed information.

Resource naming rules

These rules and restrictions apply to all IMS macros.

- Names cannot include a blank, comma, period, hyphen, or equal sign.

- All PSB and DMB names must begin with an alphabetic character (alphabetic = A through Z, #, \$, and @) followed by zero to seven alphanumeric characters.
- The PSB name, DBF#FPU0 is a reserved name.
- For route codes, DBFDFRT1 is a reserved name.
- Logical terminal names and transaction codes must be one to eight alphanumeric characters in length. (Alphanumeric = A through Z, #, \$, and @, 0 - 9.) Each name within the set comprising LTERM names and transaction codes must be unique.
- User IDs that are passed to RACF must be one to eight alphanumeric characters, that is, letters A through Z, digits 0 - 9, and the national characters #, \$, and @.

For ETO terminals, if the user ID is used to build the LTERM structure, the user ID must be one to eight alphanumeric characters.

- Node names must be unique among themselves, but can duplicate LTERM names, transaction codes, or subpool names.
- Subpool names must be unique among themselves, but can duplicate LTERM names, transaction codes, or node names.
- IMS null words must not be used as resource names (FOR, TO, ON, AFTER, and SECURITY). Also, resource names must not begin with DFS (except for DFSIVPxx and DFSSAMxx, and DFSCONE for transactions) or DBCDM; nor should WTOR, MSDB, SDB, DBRC, BASICEDT, or ISCEDT and its aliases be used as a resource name.
- Command keywords must not be used as resource names.

Related reading: For more information about command keyword restrictions, see [List of reserved words \(Commands\)](#).

- Symbolic names can be used to define 3270 and SLU Type 2 devices. See the description of the TYPE= keyword of the TERMINAL macro statement for the format of these names. A symbolic name must be used to define the format of any 3270 display device with a screen size other than 480 or 1920 characters.
- Resource names must not end with the IMS ID or the CRC character that was chosen by coding the CMDCHAR parameter of the IMSCTRL macro. The last characters of a command are checked during multisegment command processing. If the characters match the IMS ID or the CRC, the command is assumed to be a multisegment command. Command processing waits for the rest of the command.

For example, if you define a NODE whose name ends with "IMS ID IMSA", and you issue the command **IMSADIS NODE xxxxIMSA**, the command does not run. The ending "IMSA" in the NODE name indicates a multisegment command. To run this command, enter:

```
'IMSADIS NODE xxxxIMSA. '
```

Maximum occurrences of each IMS system definition macro statement

Each IMS macro statement can appear in an IMS system definition a limited number of times.

The maximum number of IMS resources that can be defined is a design limit (that is, a theoretical limit). You should not assume that your installation can successfully define the maximum number of IMS resources that is shown in the following table. The actual limit on this number is influenced by many limiting factors in your hardware and software configuration.

If you are defining and generating resources into the IMS.MODBLKS data set that is defined as a partitioned data set (PDS), one factor that limits the number of IMS resources that can be defined is the maximum size, 16 M, of a PDS member. The actual number of IMS resources that can be defined for a MODBLKS data set defined as a PDS depends on the size of the resource control block:

- 16777215/184 (SMB length from SMBTOTSZ) = 91,180 transactions
- 16777215/112 (PDIR length from PDIRLEN) = 149,796 programs
- 16777215/48 (RCTE length from RCTELEN) = 349,525 routing codes

- Databases are limited to 32,700.

If you are defining and generating resources into the IMS.MODBLKS data set that is defined as a partitioned data set extended (PDSE), one factor that limits the number of IMS resources that can be defined is the maximum size, 2 G, of a PDSE member. The actual number of IMS resources that can be defined for a MODBLKS data set defined as a PDSE depends on the size of the resource control block:

- 2147483647/184(V14 SMB length from SMBTOTSZ) = 11,671,106 transactions
- 2147483647/112(V14 PDIR length from PDIRLEN) = 19,173,961 programs
- 2147483647/48(V14 RCTE length from RCTELEN) = 44,739,242 routing codes
- Databases are limited to 32,700.

The following table shows the maximum number of times each macro statement can occur.

Table 49. Maximum occurrences of each IMS system definition macro statement

Macro statement	Maximum occurrences
APPLCTN	149,796 for PDS 19,173,961 for PDSE
BUFPOOLS	1
COMM	1
DATABASE ¹	32,700
FPCTRL	1
IDLIST	1000
IMSCtrl	1
IMSGEN	1
LINE	1000
LINEGRP	676 - (Number of MSPLINK macros specified)
MSGQUEUE	1
MSLINK	676 or 999 ⁶
MSNAME	676
MSPLINK	676 or 999 ⁶ - (Number of LINEGRP macros specified)
NAME	999,999 - (Number of switched line macros specified)
RTCODE	349,525 for PDS 44,739,242 for PDSE
SUBPOOL	999,999 - (Number of TERMINAL and STATION macros specified)
TERMINAL ²	200,000
TRANSACT	91,180 for PDS 11,671,106 for PDSE
Transaction Edit Routines ³	255
TYPE	200,000
User routines ⁴	200

Table 49. Maximum occurrences of each IMS system definition macro statement (continued)

Macro statement	Maximum occurrences
VTAMPOOL ⁵	1

Notes:

1. In IMS execution, database allocation is limited to the number of DD names that z/OS allows.
2. Because of the size of the IMS control block, the maximum number of static terminal resources that can be defined is approximately 200,000.
Recommendation: If your system includes many terminals, use the ETO feature. By using the ETO feature, you can manage terminals more effectively during IMS online activity.
3. Transaction Edit routines are specified in the EDIT operand of the TRANSACT macro. Although the limit of TRANSACT statements is 999,999, only 255 transaction edit routines are accepted.
4. *User Routines:* Refer to the user-supplied physical terminal output and input edit routines (specified in the EDIT operand of the LINEGRP and TYPE macros).
5. VTAMPOOL is used once for each set of LU 6.1 subpools defined. It can be used multiple times within a system definition to define multiple sets of LU 6.1 subpools.
6. The MSLINK and MSPLINK maximum occurrences are 999.

Coding conventions

All IMS installation information uses the following conventions in coding macros and examples:

- Uppercase letters, stand-alone numbers, and punctuation marks must be coded exactly as shown. The only exceptions are subscripts, which are not coded.
- Lowercase letters, words, and associated numbers represent variables for which specific values can be substituted.
- A space or the lowercase "b" indicates one blank position.
- If an alternative item is underlined, it is the default. IMS assumes that if none of the items is coded, the underlined item is automatically the choice.
- You must specify positional parameters in the order shown.
- You can specify keyword parameters in any order.

APPLCTN macro

The APPLCTN macro allows you to define the program resource requirements for application programs that run under the control of the IMS DB/DC environment, and for application programs that access databases through DBCTL.

An APPLCTN macro combined with one or more TRANSACT macros defines the scheduling and resource requirements for an application program. Using the APPLCTN macro, you only describe programs that operate in message processing regions, Fast Path message-driven program regions, batch message processing regions, or CCTL threads. You do use the APPLCTN macro to describe application programs that operate in batch processing regions.

Requirement: When you define programs or transactions (using the APPLCTN and TRANSACT macros) to an IMSplex using shared queues, you must ensure that the programs and transactions are defined with the same attributes on all IMS systems in the IMSplex. If the attributes are defined differently on different IMS systems in the IMSplex, results can be unpredictable. For example, a transaction defined as conversational on one IMS and non-conversational on another IMS causes unpredictable results when messages for that transaction are put on the shared queues.

The APPLCTN macro is optional in DBCTL, DB/DC, and DCCTL environments. If you do not include this macro during stage 1 system definition, no warning is issued, and it is assumed that you define your

application programs dynamically using **CREATE PGM** and **UPDATE PGM** commands and the PGMCREAT exit routine.

This topic includes the following information:

- “Dynamic definition” on page 401
- “Syntax” on page 402
- “Positional parameters” on page 402
- “Keyword Parameters” on page 404

Dynamic definition

To define or change program resource requirements for application programs dynamically, you can use the CREATE PGM command and the UPDATE PGM type-2 command. The following table compares the APPLCTN macro keywords and the equivalent CREATE and UPDATE command keywords used for dynamic definition. Default values are shown in **bold**.

APPLCTN macro keyword	CREATE UPDATE PGM keyword equivalent	Usage comments
PSB= <i>name</i>	NAME(<i>name</i>)	
RESIDENT DOPT	RESIDENT(N Y) DOPT(N Y)	
FPTH=(NO YES <i>size</i>)	FP(N E)	The size variable is not supported on the CREATE PGM and UPDATE PGM commands. Use the keyword variable EMHBSZ(<i>size</i>) on the CREATE TRAN command instead.
GPSB= <i>name</i>	NAME(<i>name</i>) GPSB(N Y)	
LANG=(ASSEM COBOL PL/I JAVA PASCAL)	LANG(ASSEM COBOL PL/I JAVA PASCAL)	
PGMTYPE=(TP BATCH, OVLY, 1 <i>class</i>)	BMPTYPE(Y N)	The class variable is used on the CREATE TRAN and UPDATE TRAN commands.
SCHDTYPE= SERIAL PARALLEL	SCHDTYPE(SERIAL PARALLEL)	<ul style="list-style-type: none"> • SERIAL is the default on the APPLCTN macro. • PARALLEL is the default on the CREATE and UPDATE commands.
SYSID=(<i>remote system ID, local system ID</i>)		The SYSID keyword is not supported on the CREATE PGM or UPDATE PGM command. Use the keyword variables SIDL(<i>localsysid</i>), SIDR(<i>remotesysid</i>), or MSNAME(<i>msname</i>) on the CREATE TRAN and UPDATE TRAN commands instead.

Table 50. APPLCTN macro keywords and the equivalent CREATE and UPDATE command keywords used in dynamic definition (continued)

APPLCTN macro keyword	CREATE UPDATE PGM keyword equivalent	Usage comments
TRANSTAT=N Y	TRANSTAT(N Y)	The TRANSTAT keyword is optional. If a value is not specified for the TRANSTAT keyword, the system default is used.

Syntax

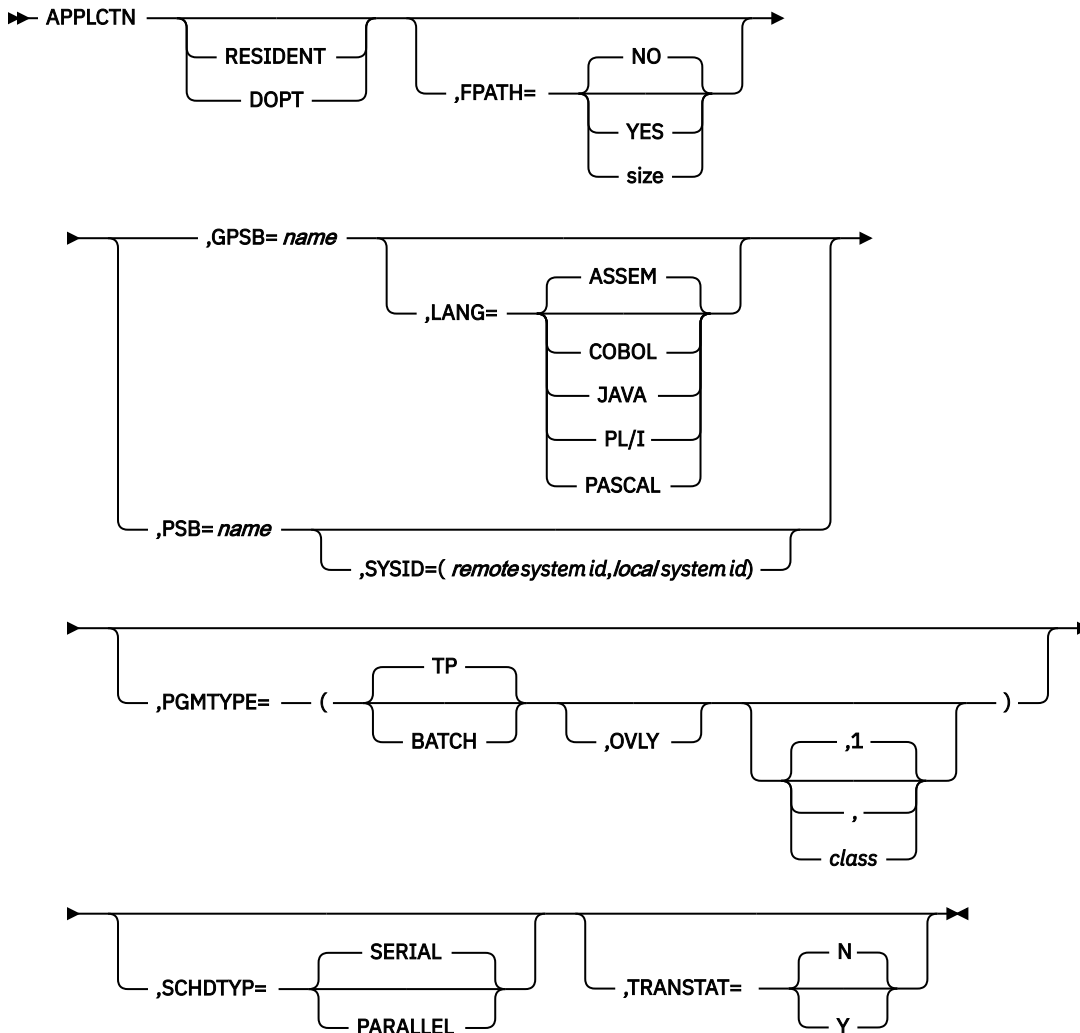

Positional parameters

The APPLCTN macro includes two positional parameters, **RESIDENT** and **DOPT**, which are mutually exclusive.

RESIDENT

Specifies that the PSB associated with this application program is to be made resident during system initialization.

DOPT

Specifies that the PSB associated with this application program is to be located dynamically.

If you specify DOPT, you cannot specify SCHDTYP=PARALLEL. In addition, when the IMS control region executes:

- Initialization does not perform a BLDL on the PSB associated with this application program. Thus the ACB for the PSB does not need to be in either an active ACBLIB data set or, if IMS manages ACBs, the IMS catalog until it is required to process a transaction. However, the DBDs that the PSB might reference must be defined in either the active ACBLIB or the IMS catalog and loaded in the online system before a DOPT PSB is scheduled. PSBs that reference DBDs that are not defined and loaded in the online system are not scheduled.
- Each time the program that is associated with this PSB is scheduled, a BLDL is performed, and the latest copy of the PSB is located. A BLDL is not performed for associated DBDs, so the DBD cannot be modified until the system is initialized again or until online change is used.
- When the program terminates, the PSB is deleted from the PSB pool as part of the termination process.

Usage information

Neither RESIDENT or DOPT is the default parameter. Rather, if neither RESIDENT or DOPT is selected, IMS system initialization causes a BLDL to be performed on the PSB associated with the application that is being defined. The PSB is not made resident (that is, loaded from the ACBLIB data set or the IMS catalog) until the application is scheduled.

If your IMS system uses ACBLIB data sets, the following restrictions apply to the dynamic PSB library:

- The PSB must reside in a library other than the primary ACBLIB and must be concatenated to it
- The concatenated library containing the PSB must be in ACBLIB format.
- The IMS.PSBLIB data set cannot be used.

When a dynamic PSB is scheduled, if the PSB resides in the first concatenated ACBLIB data set of the IMSACB DD statement, IMS stops the PSB and sends an error message to the master terminal. The PSB is not scheduled. If the dynamic PSB is added to the concatenation of the IMS.ACBLIB, causing the data set to be expanded to a secondary extent, that PSB is not available to the online system until the ACBLIB is closed and reopened by IMS.

If the IMS management of ACBs is enabled in your environment (ACBMGMT=CATALOG), dynamic PSBs are not required to be in concatenated data sets. The ACB for the dynamic PSB needs to be only in the IMS directory data set of the IMS catalog.

For MSC remote applications, the APPLCTN macro provides documentation and a reference for its transactions. It does not generate a control block. The PSB need not be generated in systems where it is used as a remote reference. The PSB name is defined here for documentation purposes.

To dynamically reassign a transaction from remote to local processing, a control block must be present in the local system.

Thus, if dynamic reassignment is desired, a transaction must be defined as local. That is, it must be under a local application having the same PSB name as the remote application (using the APPLCTN macro without a SYSID parameter). If dynamic reassignment is not desired, local definition is unnecessary.

Online changes to both the RESIDENT and DOPT options can be made using a MODBLKS system definition. However, PSBs associated with new application programs defined as RESIDENT (that is, changed from NONRESIDENT or DOPT to RESIDENT) during a MODBLKS system definition are not made resident until the next restart of IMS. Until that time, they are to be treated as nonresident. Online changes made to already-resident PSBs (using an ACBGEN) cause the PSB to be treated as nonresident until the next IMS restart.

MPPs scheduled against dynamic PSBs are not allowed to go through the quick reschedule process or become pseudo WFIs.

Requirement: If, after IMS initialization, an ACB that was originally generated as LANG=*non-Java* and DOPT, is changed to LANG=JAVA and DOPT (and IMS is not restarted), you must ensure that both of the following regions are available the first time IMS tries to schedule the affected transaction:

- An MPP region that has the same class as the application
- A JMP region that has the same class as the application

The reverse situation is also true. If, after IMS initialization, an ACB that was originally generated as LANG=JAVA and DOPT, is changed to LANG=*non-Java* and DOPT (and IMS is not restarted), you must ensure both of the following regions are available the first time IMS tries to schedule the affected transaction:

- A JMP region that has the same class as the application
- An MPP region that has the same class as the application

Keyword Parameters

To find which parameters apply to your IMS configuration, refer to [“Selecting the appropriate macros to define your system”](#) on page 5.

FPATH=

Specifies whether (YES) or not (NO) this is a Fast Path-exclusive application program. FPATH=size, which determines the EMH buffer size required to run the transaction, overrides the EMHL execution parameter and implies FPATH=YES. The minimum specification for FPATH=size is 12; the maximum is 30720. FPATH=YES implicitly defines a wait-for-input (WFI) application program. The PGMTYPE= parameters that define the overlay structure and class are invalid if FPATH=YES is specified. The SYSID= parameter is also invalid if FPATH is specified.

If FPATH=YES is specified during a MODBLKS system definition, Fast Path must have been previously defined for the online system to which this change is made.

Fast Path-potential transactions must be able to run under two applications. One of these applications must be defined with FPATH=YES; the other with FPATH=NO. The application with FPATH=YES must also be defined with a routing code that can be assigned by the user Input Edit/Routing exit routine. This routing code can have the same name as the Fast Path-potential transaction.

FPATH=NO must be specified if specifying LANG=JAVA.

When Fast Path is included during system definition, the FPBUF parameter on the TERMINAL macro statement is ignored, except to determine the default EMH buffer size. Fast Path buffers are provided by the EMHB pool, which expands and contracts dynamically depending on the number of ETO terminals concurrently entering Fast Path transactions.

GPSB=

Causes the scheduling process of all environments to generate a PSB containing an I/O PCB and an alternate modifiable PCB.

With the GPSB= keyword, you do not need to pre-define or store the application control blocks (ACBs) for the application, thus eliminating I/O to either an ACBLIB data set or the IMS catalog.

The name is 8 characters in length with blank spaces included.

GPSB= generates an I/O PCB named IOPCB (with 3 blank spaces on the right). The modifiable, alternate PCB is named TPPCB1 (with 2 blank spaces on the right). With an alternate modifiable PCB, an application can use the CHNG call to change the output destination and send output to a destination other than the input destination.

You can add the GPSB option to an existing application with a MODBLKS online change or, if dynamic resource definition is enabled, by issuing the UPDATE PGM command. However, neither the MODBLKS online change nor the UPDATE PGM command removes the old PSB from the IMS system. In IMS systems that use an ACBLIB, the GPSB option does not take effect unless the ACBLIB is changed with online change. In IMS systems that manage ACBs for you, the PSB can be removed either by

submitting a DDL DROP PROGRAMVIEW statement or by using the IMS Catalog Purge utility and restarting IMS.

To add a new application with the GPSB option, perform a MODBLKS system definition or, if dynamic resource definition is enabled, issue the CREATE PGM command.

If LANG=JAVA is specified and the Java application is a message processing program, the name specified on GPSB= is the name of the Java application class.

LANG=

Defines the language interface of the application program. LANG= is used only with GPSB=. You can use the following values with the LANG= keyword:

- ASSEM
- COBOL
- JAVA
- PL/I
- PASCAL

ASSEM is the default value.

Requirements:

- If LANG=JAVA is specified, then FPATH=NO must also be specified.
- If, after IMS initialization, an ACB that was originally generated as LANG=*non-Java* and DOPT, is changed to LANG=JAVA and DOPT (and IMS is not restarted), you must ensure that both of the following regions are available the first time IMS tries to schedule the affected transaction:
 - An MPP region that has the same class as the application
 - A JMP region that has the same class as the application

The reverse situation is also true. If, after IMS initialization, an ACB that was originally generated as LANG=JAVA and DOPT, is changed to LANG=*non-Java* and DOPT (and IMS is not restarted), you must ensure both of the following regions are available the first time IMS tries to schedule the affected transaction:

- A JMP region that has the same class as the application
- An MPP region that has the same class as the application

PGMTYPE=

Specifies whether the program executes in a BMP-type region or not. A BMP-type region includes BMP and JBP regions. The following PSBs can be defined with either BATCH or TP:

- PSBs scheduled by Db2 for z/OS stored procedures.
- PSBs scheduled by programs running under WebSphere Application Server for z/OS.
- PSBs scheduled by programs running under IBM InfoSphere® Data Replication for IMS for z/OS.
- Other users of the ODBA interface.

TP

Specify TP for:

- Programs that execute in IMS TM MPP, JMP, and IFP regions.
- PSBs scheduled by IBM CICS Transaction Server for z/OS programs using DBCTL.
- Other users of the DRA interface.

This is the default.

BATCH

Specify BATCH for programs that execute in BMP-type regions, such as IMS BMP and JBP regions. Any associated transactions are assigned normal and limit priority values of zero (0).

OVLY

No longer used by IMS but is retained for compatibility. An execution time parameter, OVLA on procedure DFSMPR, is available when starting an MPP to indicate whether the overlay supervisor should be preloaded by IMS.

If a program is changed from batch to online using the online change facility, you must enter the /ASSIGN command to assign nonzero current, limit, and normal priorities (CPRI, NPRI, and LPRI keywords) to the transactions using that program. This is because the online change facility does not alter attributes that are changeable through the /ASSIGN command. Regardless of whether you specify new values for the transaction in the MODBLKS system definition, they are ignored during /MODIFY processing.

If FPATH=YES is specified:

- TP specifies a message-driven Fast Path application program
- BATCH cannot be specified. If BATCH is specified, an error message is issued. Fast Path nonmessage-driven application programs are not supported, and should be changed to run as BMPs.
- The PGMTYPE= parameters that define the overlay structure and class are not valid.
- The SYSID= parameter is not valid.

The third parameter of the PGMTYPE= keyword specifies the class to which the transaction codes specified in the following TRANSACT macro statements are to be assigned. This parameter must be a decimal number from 1 to 999. This value must not exceed the value given (by specification or default) on the MAXCLAS= keyword of the IMSCTRL macro. The default is 1. If the transaction code class is to be specified in the individual TRANSACT macro statements, this parameter need not be coded. If the transaction code class is specified in both the APPLCTN and TRANSACT macro statements, the APPLCTN macro specification is ignored, and the TRANSACT macro specification is used.

If the PGMTYPE= (,class) parameter is to be changed online, the class value that is specified cannot exceed the definition (by specification or default) on the MAXCLAS= keyword of the IMSCTRL macro in the online system to which this change is to be made.

The numeric class subparameter must not be specified if FPATH=YES is specified.

PSB=

Specifies the name of the PSB associated with this application program definition. Each local PSB name must be unique. A remote and a local application can each be defined as having the same PSB name. This is required in order to dynamically reassign a transaction from remote to local processing. The first character of the PSB name must be a letter. If PGMTYPE=TP, the PSB name must also be the program name.

SYSID=

Specifies in the multiple-IMS system configuration, the system identification (SYSID) of the remote system (that system on which the application executes) and the SYSID of the local system (the originating system to which the responses are returned). The values specified must be numbers in the range from 1 to 2036.

The remote SYSID specified must also be defined in an MSNAME macro statement, but the local SYSID can be defined in any or all the MSNAME, TRANSACT, and APPLCTN macro statements. If SYSID is specified, all other keywords except PSB are ignored.

If the SYSID parameter is specified in the APPLCTN macro statement, you need not specify the SYSID in the TRANSACT macro statement. If the SYSID is specified in both the APPLCTN and TRANSACT macro statements, the TRANSACT specification is ignored.

The SYSID parameter is independent of the link type (BSC, CTC, MTM, VTAM) specified on the TYPE= keyword of the MSPLINK macro statement.

Because the values associated with the SYSID= keyword can be changed using an /MSASSIGN command, you should not add SYSID= to an existing APPLCTN macro for a MODBLKS system

definition. Doing so causes the local application to be deleted after an online change sequence of commands.

A PSB cannot be initially defined or redefined from remote to local by using the SYSID= parameter on the APPLCTN macro during an online change.

The SYSID keyword parameter is invalid if FPATH=YES is specified.

SCHDTYP=

Specifies whether (PARALLEL) or not (SERIAL) this application program can be scheduled into more than one message region or batch message region simultaneously. The default value is SERIAL.

When the SCHDTYP= parameter is changed by a MODBLKS system definition from serial to parallel or vice versa, and the PSB, defined as resident, is not changed, the PSB is considered non-resident until the next IMS restart.

SCHDTYP=PARALLEL and the positional parameter DOPT are mutually exclusive.

If you specify SCHDTYP=SERIAL, omit the PARLIM parameter in the TRANSACT macro and accept the default (65 535). Also, omit the MAXRGN parameter in the TRANSACT macro or set it equal to 0.

TRANSTAT=

Specifies whether transaction level statistics are logged. If you specify Y, transaction-level statistics are written to the log in an X'56FA' log record.

N

Transaction-level statistics are not logged.

Y

Transaction-level statistics are logged.

The TRANSTAT keyword is optional. If a value is not specified for the TRANSTAT keyword, the system default (**N**) is used. The system default for the transaction-level statistics parameter is set with the TRANSTAT parameter in the DFSDFxxx PROCLIB member. Use the TRANSTAT keyword on the CREATE PGM or CREATE PGMDESC command to override the system default when creating a program or program descriptor.

COMM macro

The COMM macro specifies general communication requirements that are not associated with any particular terminal type. COMM is always required for terminal types that are supported by VTAM. It is optional for BSAM, GAM, and ARAM terminal types.

The COMM macro can also be required to specify additional system options, such as support for MFS on the master terminal.

The COMM macro should be placed before the data communication specifications in the stage 1 input sequence.

This topic includes the following information:

- [“Dynamic definition” on page 407](#)
- [“Supported environments” on page 407](#)
- [“Syntax” on page 408](#)
- [“Positional parameters” on page 408](#)
- [“Keyword parameters” on page 408](#)

Dynamic definition

General communication requirements cannot be dynamically defined.

Supported environments

The COMM macro can be used in the IMS DB/DC and DCCTL environments.

Syntax

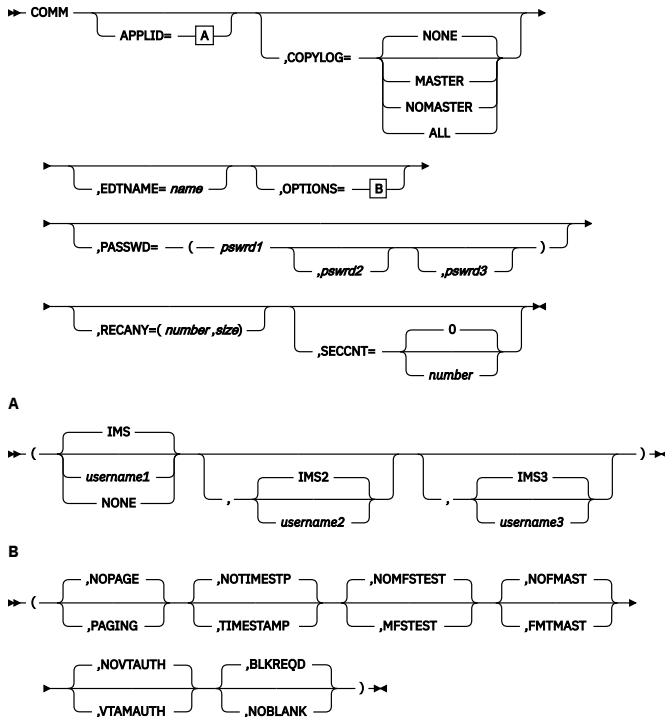

Positional parameters

The COMM macro does not include positional parameters.

Keyword parameters

To find which parameters apply to your IMS configuration, refer to [“Selecting the appropriate macros to define your system”](#) on page 5.

AOEXIT=

No longer supported.

APPLID=

Specifies the application identification in the VTAM ACBs if VTAM is used. The default value is IMS.

For XRF, specify two VTAM APPLIDs: *username1* and *username2*. These two parameters correspond to the two XRF systems. The defaults are IMS and IMS2, respectively. When MNPS is used for XRF, *username1* and *username2* refer to the APPLID ACBs in the two XRF systems.

All three user name values can be overridden by specifying APPLID1=, and either APPLID2= or APPLID3=, or both, in the IMS or DCC procedures. These keywords can also be specified in the DFSPBIMS or DFSPBDCC members. *Username3* can match either *username1* or *username2*, but no two APPLIDs can be active in the network at the same time.

The defaults are IMS, IMS2, and IMS3, respectively.

If NONE is specified:

- The MSVERIFY program (DFSUMSV0) cannot validate that the APPLID names of the IMS system and its partner match if MSC/VTAM links are defined.
- Either the job step name of the job to bring up the IMS control region is used, or the name of the started task (if a started task is used for the IMS control region) is used.

If you specify APPLID=NONE and you issue a /DIS ACTIVE DC command, the output of the command is APPLID=NONE.

APPLID=NONE cannot be specified for XRF.

COPYLOG=

Specifies the different categories of command and command response messages for which a copy is to be printed on the secondary master terminal.

If you want hardcopy logging, you must define a secondary master terminal.

The default is NONE.

NONE

Specifies that the commands listed in “[#unique_438/unique_438_Connect_42_ip0i2mca52146243](#)” on page 409 and command responses from terminals are not to be printed on the secondary master terminal. The queuing for the secondary master terminal of messages not in the categories described in “[#unique_438/unique_438_Connect_42_ip0i2mca52146243](#)” on page 409 is not affected by the COPYLOG statement.

MASTER

Specifies that copies of commands listed in “[#unique_438/unique_438_Connect_42_ip0i2mca52146243](#)” on page 409 and command responses from the master terminal are to be printed on the secondary master terminal.

NOMASTER

Specifies that copies of the commands listed in “[#unique_438/unique_438_Connect_42_ip0i2mca52146243](#)” on page 409 and command responses from terminals other than the master terminal are to be printed on the secondary master terminal.

ALL

Specifies that the commands listed in “[#unique_438/unique_438_Connect_42_ip0i2mca52146243](#)” on page 409 and command responses from all terminals are to be printed on the secondary master terminal.

COPYLOG does not affect system messages, which continue to be logged to the secondary master terminal.

The commands that can be copied to the secondary master terminal are:

The following commands can be copied to the secondary master terminal:

- /ACTIVATE
- /ASSIGN
- /CHECKPOINT
- /CLSDST
- /COMPT
- /DBDUMP
- /DBRECOVERY
- /DELETE
- /DEQUEUE
- /DISPLAY
- /IDLE
- /MONITOR
- /MSASSIGN
- /OPNDST
- /PSTOP
- /PURGE
- /QUIESCE
- /RCLSDST
- /RCOMPT

/RSTART
/START
/STOP
/TRACE
/UNLOCK SYSTEM

Other commands can be logged but are not under the control of COPYLOG as /MSVERIFY is, for example.

The COPYLOG specification can be dynamically changed at execution time by the /SMCOPY operator command.

EDTNAME=

Names the ISC edit process for LU 6.1 nodes. The name specified becomes a synonym for ISCEDT, the default name that can be input and is output on the DPN parameter of the SCHEDULER function management header. When this name is input to IMS on the DPN parameter of the ATTACH or SCHEDULER function management header, it causes IMS to use the ISC edit process. The name used on the EDTNAME parameter cannot be the same as any MFS message input descriptor (MID) name used as an input ATTACH DPN parameter to invoke an MFS process.

FESEXIT=

In IMS 15.4, this parameter is replaced by the IMS execution parameters FESEXIT and FESTIM.

Specifies whether (YES) or not (NO) the Front End Switch exit routine is to be included in the IMS nucleus.

The default is NO.

The *timeout_value* specifies a timeout value in seconds. A *timeout_value* specifies the time interval in which a reply for an FES message must be received. If no reply is received by the front-end system in time, timeout processing begins. The minimum value is 1, and the maximum value is 300.

If FESEXIT=YES is specified without a timeout value, the default for the *timeout_value* parameter is 30.

The FES exit routine must be placed in the data set defined by the USERLIB= keyword of the system definition MSGEN macro before the execution of IMS stage 2 system definition. The name of the exit routine must be DFSFEBJ0.

MFSEXIT=

In IMS 15.4, this parameter is replaced by the IMS execution parameters MFSEXITF and MFSEXITS.

The variable *fieldexitnum* specifies the highest-numbered MFS Field Edit exit routine to be included in the generated system. *fieldexitnum* must be a decimal number greater than or equal to 0 and less than the default or specified value for the *segmentexitnum* parameter. The default is 0.

The *segmentexitnum* value specifies the lowest-numbered MFS Segment Edit exit routine to be included in the generated system. The *segmentexitnum* must be a decimal number greater than the default or specified value for the *fieldexitnum* parameter and less than or equal to 127. The default is 127.

Recommendation: Make lower-numbered exit routines be field exit routines, even though the lower-numbered exit routines can be segment exit routines, or can be a mixture of field and segment exit routines. An additional recommendation is that the higher-numbered exit routines be segment exit routines, although the higher-numbered exit routines can be field exit routines, or can be a mixture of field and segment exit routines.

An MFSEXIT=(14,120) specification indicates that user-supplied MFS Field Edit exit routines DFSME001 through DFSME014 and user-supplied MFS Segment Edit exit routines are IMS-supplied routines and are always included in the generated system when MFS requirements exist.

User-supplied MFS exit routines are included in the system definition-generated online control blocks module DFSIBLKx. Therefore, MFS exit routine specifications can be changed by an IMS CTLBLKS, NUCLEUS, ON-LINE, or ALL system definition. The MFSEXIT keyword specification is ignored when MFS exit requirements do not exist in the generated system.

OPTIONS=

The parameters included in this description are not position dependent within the operand sublist. If any terminal or password security options are specified here and also in the IMSGEN statement, a warning message is issued.

NOPAGE | PAGING

Defines whether (PAGING) or not (NOPAGE) the terminal paging feature is included in the defined system. The default is NOPAGE. If 3270 or SLU 2 devices are included, or if SLU P, LU 6.1, or 3600 devices defined with MFS are included, the paging capability is automatically included.

NOTIMESTP | TIMESTAMP

Specifies whether (TIMESTAMP) or not (NOTIMESTP) the system message time stamp feature is desired in the defined system. The default is NOTIMESTP.

When TIMESTAMP is specified, the time at which a message was generated is inserted between the message number and the message text for each message in the table.

NOMFSTEST | MFSTEST

Specifies whether (MFSTEST) or not (NOMFSTEST) the Message Format Service test facility, MFSTEST, is to be included in the generated system. Specifying MFSTEST is invalid for systems not containing MFS terminals. The default is NOMFSTEST.

Specifying a numeric value on the COMM macro statement is no longer recommended; for compatibility reasons it is still allowed, but any numeric value is ignored. When a numeric value is specified the NOMFSTEST default is overridden and MFSTEST is set; if MFSTEST=NO is specified on the IMSGEN macro, it is also overridden.

Using MFSTEST can degrade IMS performance due to MFSTEST use of the CIOP pool.

NOFMAST | FMTMAST

Specifies whether (FMTMAST) or not (NOFMAST) the IMS-provided support for MFS on the master terminal is to be used. This support is available for the following devices used as the master terminal:

- 3277 model 2
- 3270 displays that have a 24 x 80 screen and use symbolic names
- 3277 model 2 when defined as SLUTYPE2

NOUSEMSG | USERMSG

In IMS 15.4, these parameter are replaced by the IMS execution parameter USERMSG.

Specifies whether (USERMSG) or not (NOUSEMSG) the user-supplied user message tables module DFSCMTU0 is to be included within the generated system.

NOVTAUTH | VTAMAUTH

Specifies whether (VTAMAUTH) or not (NOVTAUTH) IMS is to use the VTAM authorized path for communicating.

Related reading: Refer to *ACF/VTAM Macro Language Guide* for information about the authorized path facility. These parameters can be overridden by the JCL prepared for system execution.

BLKREQD | NOBLANK

Specifies whether the 1- to 8-byte transaction code requires a trailing blank. NOBLANK lets you enter a 1- to 8-byte transaction code without having to specify a trailing blank.

The selection of NOBLANK indicates that a blank does not have to be specifically entered after a one- to eight-byte transaction code, but if data is being included after the transaction code, then a blank must be inserted between the code and the data.

PASSWD=

Specifies, when XRF is not used, that one password is to be specified in the VTAM ACB.

This password is checked by VTAM. If no password is specified, either in the VTAM ACB or in the PASSWD1= parameter, and VTAM requires one (during VTAM system definition), the IMS VTAM ACB is not initialized.

For XRF, you should specify two VTAM passwords that correspond to the two XRF systems. If only one password is specified, it is used as the password for both XRF systems.

RECANY=

This parameter is required only when defining VTAM terminals. It defines the number and size of the RECEIVE ANY buffers.

This keyword and its parameters are optional and can be either overridden with execution-time parameters or defaults can be used if not specified by either of these methods.

number

Specifies the number of VTAM RECEIVE ANY buffers to be present in the IMS system. Valid values are from 1 to 500. The default is 16 if not specified during system definition or with execution-time parameters. You can override this specification with the EXEC parameter RECA= in the IMS procedure.

When MNPS is used for XRF, this parameter specifies the number of buffers for the MNPS ACB. IMS automatically allocates one additional buffer for the APPLID ACB.

Specifying too many buffers does not improve performance and can result in excessive resource consumption, especially high CPU utilization. You can check current and maximum use by looking in the X'450D' log record.

size

Specifies the size of the largest RECEIVE ANY buffer. This size must be large enough to handle maximum input from any VTAM-attached terminal. The minimum acceptable size is 50; the maximum is 30720. The default is 1920 if not specified during system definition or with execution-time parameters. The resulting usable input buffer size for any terminal can be calculated as follows for the devices shown:

3601: Size is record size plus header. The header size is 2 bytes if MFS is not used and 11 bytes if MFS is used.

3270: Size is the input data stream length. The minimum size is 300 bytes and a reasonable maximum size is 3842 bytes.

SLU 1, SLU 2: Record size should be equal to or greater than the largest input record to be received.

SLU P: Size is record size plus header. The header size is 5 bytes if MFS is not used and variable from 7 bytes to 40 bytes if MFS is used.

LU 6.1: Size is record size plus header. The header size without MFS is variable from 0 bytes to 45 bytes. The header size with MFS is variable from 17 bytes to 52 bytes.

NTO: Record size should be equal to or greater than the largest input record to be received.

For all VTAM terminals, the RECANY buffer size must be a decimal value that can be expressed by the algorithm $X \text{ times } 2 \text{ to the power of } Y$. X must be a value from 8 through 15, and Y must be a value from 3 through 11. This is a VTAM restriction. Thus, for example, the value 144 (representing 9×2^4) or the value 28672 (representing 14×2^{11}) are acceptable values.

Related reading: Details of this VTAM restriction are in *z/OS V1R2 Communications Server: SNA Programming*.

These are valid VTAM buffer sizes. This restricts the valid VTAM buffer sizes to one of the following decimal values:

112
120
128
144
160
176
192
208
224
240
256
288
320
352
384
416
448
480
512
576
640
704
768
832
896
960
1024
1152
1280
1408
1536
1664
1792
1920
2048
2304
2560
2816
3072
3328
3584
4096
4608
5120
5632
6144
6656
7168
7680
8192
9216

10240
11264
12288
13312
14336
15360
16384
18432
20480
22528
24576
26624
28672
30720

IMS converts the specified decimal value to the format required for the bind parameter fields and places the value into the appropriate field in the bind parameter list. If the maximum request unit (RU) value specified cannot be converted exactly into the bind format, the value is rounded down to the next-lower value bind format for inbound RUs and rounded up to the next-higher value bind format for outbound RUs.

SECCNT=

Specifies the maximum number of terminal and password security violations to be accepted per physical terminal before master terminal notification of such violation. The default is 0, which nullifies notification of the master terminal. The number specified can be 0, 1, 2, or 3. This value is reset to 0 upon successful signon and does not continue across transactions.

If SECCNT is not 0, the master terminal is notified for every violation.

SIMEXIT=

In IMS 15.4, this parameter is replaced by the IMS execution parameter SIMEXIT.

Specifies whether (YES) or not (NO) the Shared Printer Message Router exit routine is to be included in the IMS nucleus.

This exit routine must be placed in the data set defined by the USERLIB= keyword of the system definition MSGEN macro statement before the execution of stage 2. The name of the exit routine must be DFSSIMLO. A default exit routine is not provided.

The exit routine is bypassed unless SIMEXIT=YES is specified. If SIMEXIT=YES is specified, the exit routine DFSSIMLO is called when a message is queued for terminals defined with OPTIONS=SHARE on the TERMINAL macro statement.

When SIMEXIT=NO, the default, the router module assumes that /OPN is always simulated when output is enqueued for a terminal defined as OPTIONS=SHARE on the TERMINAL macro statement. Even if SIMEXIT=NO is specified, the module DFSSIMLO can be manually bound into the nucleus.

Usage information

The keyword parameters that follow are no longer used by the COMM macro; if they are specified, they are ignored:

- NOPSWD, PASSWD, FORPSW
- NOTERMNL, TERMINAL, FORCTERM
- NOMSPEX, MSPEXIT
- NOMSLEX, MSLEXIT

DATABASE macro

Use the DATABASE macro statement to define the set of physical databases that IMS is to manage.

The DATABASE macro is optional, and IMS issues no warning if it is not included during Stage 1 processing. Databases can be added later to the online system using the commands CREATE DB and UPDATE DB.

One DATABASE macro instruction must be specified for each HSAM, HISAM, and HDAM database. Two DATABASE macro instructions are required for a HIDAM database: one for the INDEX DBD and one for the HIDAM DBD. One DATABASE macro instruction must be included for each secondary index database that refers to any database defined to the online system.

For Fast Path, a DATABASE macro statement must be included for each Main Storage Database (MSDB) and Data Entry Database (DEDB) to be processed.

A database that is defined in an ALL or MODBLKS system definition cannot be converted into a HALDB partition without a cold start of IMS. A cold start is required even if the database is deleted online. After the cold start, the database must be redefined as a HALDB partition.

A database that is defined as a HALDB partition to DBRC and IMS cannot be redefined in an ALL or MODBLKS system definition without a cold start of IMS. A cold start is required even if the database is deleted online.

This topic includes the following information:

- [“Dynamic definition” on page 415](#)
- [“Supported environments” on page 415](#)
- [“Syntax” on page 415](#)
- [“Positional parameters” on page 416](#)
- [“Keyword parameters” on page 416](#)

Dynamic definition

To dynamically define the set of physical databases that IMS is to manage, you can use the CREATE DB and UPDATE DB type-2 commands. The following table compares the DATABASE macro keywords and the equivalent CREATE and UPDATE command keywords used for dynamic definition. Default values are shown in **bold**.

DATABASE macro keyword	CREATE UPDATE DB keyword equivalent
DBD= <i>name</i>	NAME(<i>name</i>)
ACCESS= EX RO RD UP	ACCTYPE(EXCL BRWS READ UPD)
RESIDENT	RESIDENT (N Y)

Supported environments

The DATABASE macro is optional and can be used in the IMS DBCTL and IMS DB/DC environments.

Syntax

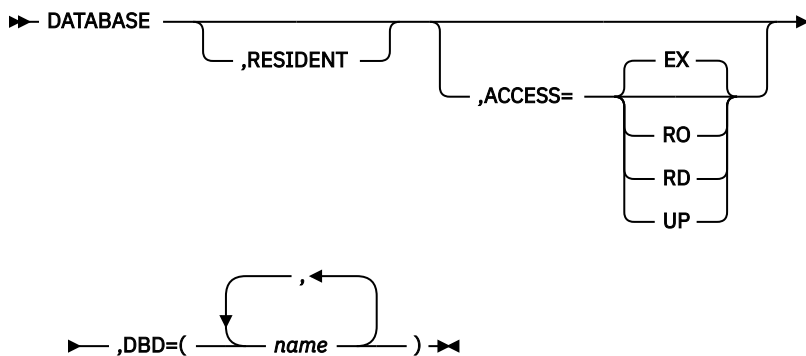

Positional parameters

RESIDENT=

Indicates that the DMB directory control block created for this DATABASE statement should reside in storage during system and DBCTL initialization.

Fast Path makes the database control blocks resident in storage during system initialization regardless of whether the RESIDENT option is specified.

Online changes to the RESIDENT option are permitted. However, DMBs associated with new databases defined as RESIDENT are not made resident until the next IMS restart. Until that time, they are treated as nonresident. Changes to a RESIDENT DMB (from an ACBGEN) cause that DMB to be treated as nonresident until the next restart of IMS.

Keyword parameters

To find which parameters apply to your IMS configuration, refer to [“Selecting the appropriate macros to define your system”](#) on page 5.

ACCESS=

When used with the database-sharing level declared to database recovery control (DBRC), this parameter specifies the access for the defined database, that is, how the subsystem requesting access plans to use the database.

The ACCESS parameter can be modified by a /START command during IMS execution. Because this parameter can be changed using a /START DATABASE command, online changes to the ACCESS keyword have no effect until the next cold start.

You cannot specify an ACCESS value for MSDBs and GSAM. The possible ACCESS values are:

EX (exclusive)

Indicates that the named database can be accessed exclusively by this IMS subsystem. This is the default for ACCESS. Concurrent access to this database by other subsystems is prohibited by DBRC. Unless this is a DEDB, PCBs that refer to this database are scheduled, regardless of the PROCOPT values specified in PSBGEN.

Concurrent image copy cannot be run against a database with ACCESS=EX. If you are running with high-speed sequential processing (HSSP), you must specify ACCESS=EX or ACCESS=UP.

RD (read)

Indicates that the named database can only be read by this subsystem. The database is opened for input only. No application programs are allowed to physically update this database.

RO (read only)

Indicates that the named database is read-only in this IMS subsystem. This database is opened for input only. PCBs that refer to this database are allowed only if PROCOPT=GO is specified in PSBGEN.

UP (update)

Indicates that the named database can be updated and read. PCBs that refer to this database can be scheduled regardless of their PROCOPT values.

If you are running with high-speed sequential processing (HSSP), you must specify ACCESS=UP or ACCESS=EX.

DBD=

Specifies the name of one or more database descriptions (DBDs). If more than one DBD name is specified, each is assumed to have the same characteristics as any positional parameter specified or used by default. The first character of the name must be a valid alphabetic character (A through Z, #, \$, or @). At execution time, the DBD must have been processed by the block builder utility program. It must exist as a member in the partitioned data set named in the IMSACB DD statement (IMS.ACBLIB). If the DBD has not been processed by the block builder utility program, and therefore, is not present in the ACBLIB data set, the database is locked at execution time. This parameter is required.

Example:

```
DATABASE DBD=(N1,N2,N3)
```

DFSMDA macro

Use the Dynamic Allocation macro (DFSMDA) to build a member (that is, one or more parameter lists) for naming data sets that can participate in dynamic allocation and deallocation. Members include databases, DEDBs, and data sets.

To use DFSMDA you must catalog all specified database data sets. However, you do not need to initially allocate them through control region JCL.

IMS users and IBM CICS Transaction Server for z/OS users can dynamically allocate IMS databases. For Fast Path databases, if the database data sets to be allocated are registered in DBRC, the information required to dynamically allocate the data sets is obtained from DBRC. You do not need to supply DFSMDA members for them. When the dynamic allocation information is obtained from DBRC, the DISP= used to allocate the data sets is either DISP=OLD or DISP=SHARE depending on the following:

- If SHARELVL=0, DISP=OLD is used.
- If SHARELVL=1, 2, or 3, DISP=SHARE is used.

DFSMDA is not a system definition macro.

The priority of allocation information is shown in the following table.

Table 52. Allocation information priorities

	DBRC	DD statement	DFSMDA member
DEDBs and MSDBs	1	2	3
All others	N/A	1	2

Database data sets specified in DFSMDA are allocated at different times depending on whether you are running in an IMS DB/DC, IMS batch, or CICS environment. The environment requirements are:

- **IMS DB/DC** database data sets are allocated either when a /START command is issued for the database or when an IMS application program is scheduled. You deallocate the data set by the /DBR command. If a database data set is specified in the JCL, it is allocated by z/OS during control region startup. You can deallocate it with the /DBR command and reallocate it with the /START command.
- **IMS batch** database data sets are allocated near the beginning of the job step, before the batch application starts execution.

Dynamic allocation is always attempted for all non-JCL allocated databases defined in the PSB being executed. This is performed by searching the JOBLIB/STEPLIB concatenation for DFSMDA members,

unless dynamic allocation is disabled (for batch only) by the presence of the NODYNALLOC statement in your DFSVSMxx member.

If a batch job uses a PSB with more database PCBs than are necessary for a particular job, you can avoid dynamic allocation of the unnecessary databases while still maintaining a library of DFSMDA members for all databases belonging to the PSB. You have two methods of doing this:

- You can include the NODYNALLOC statement in your DFSVSMxx member and include DD statements for only the necessary databases in your job JCL. The library of DFSMDA members does not need to be removed from the JOBLIB/STEPLIB concatenation because the NODYNALLOC statement disables batch dynamic allocation.
- You can maintain separate libraries of DFSMDA members, which can be included or excluded from the JOBLIB/STEPLIB concatenation as needed. DFSMDA members need not be kept in your IMSVS.SDFSRESL.

For example, you can maintain one main library of DFSMDA members for all the databases for a PSB and maintain several subset libraries. You concatenate only the library that is appropriate for the job being run. Dynamic allocation searches the entire JOBLIB/STEPLIB concatenation for DFSMDA members, so you must remove or alter all libraries that contain undesired members.

If the databases for which your program has update intent have logical relationships or secondary indexes, those additional databases containing the logical relationships or secondary indexes can also be allocated, whether by JCL or DFSMDA members. To cause dynamic allocation of a logically related database, change the PROCOPT to indicate update intent. To dynamically allocate a secondary index, change the PROCOPT to indicate update intent or include a PCB with PROCSEQ= for the secondary index.

If the PCB specifies a PROCOPT that does not indicate update intent, no intent is propagated to a logically related database or to a secondary index, and dynamic allocation is not attempted for either of these related databases.

- **CICS** database data sets are allocated when an application program issues a schedule call for the PSB. Deallocation occurs, for example, during the processing of **STOP** and **RECOVERDB** commands issued against the database.

You can dynamically allocate online log data sets (OLDS), write ahead data sets (WADS), and system log data sets (SLDS) if they are named in the DFSMDA macro. The DFSMDA macro must be defined to permit SLDS input to IMS to restart in z/OS.

When you start an OLDS using the **/START** command, the OLDS must be defined in the DFSMDA macro, even if it is allocated in JCL.

The IMS Monitor data set can also participate in dynamic allocation and deallocation. The IMS Monitor data set is allocated when it is started with the **/TRACE ON** command and deallocated when it is stopped with the **/TRACE OFF** command. It need not be initially allocated through JCL. It must not be cataloged if residing on tape; it must be cataloged if on DASD.

Recommendation: If you use the multiple DEDB area data set facility, register all data sets belonging to that area in either DBRC or DFSMDA.

The specified areas are allocated either when a **/START** command is issued for the area or when an application program attempts to use the area. The area is deallocated by **/STOP AREA**. Multiple areas can be deallocated by **/STOP ADS**.

In an XRF environment, all database and area data sets must be dynamically allocated.

Supported environments

The IMSDALOC macro can be used in the IMS DB/DC, BATCH, and DBCTL environments.

Syntax

The DFSMDA macro is coded as a z/OS macro. The statement label is optional, the macro "DFSMDA" is coded after one or more blanks, and additional parameters are separated by blanks. z/OS continuation rules apply.

The DFSMDA macro has several statement types (as indicated by the TYPE= parameter), each of which uses different additional parameters. Code the statements types as follows:

1. One TYPE=INITIAL statement to start the parameter list build.
2. As many of the other TYPE= statements as necessary. The maximum number of TYPE=DATABASE statements allowed is 250.
3. One TYPE=FINAL to end the list.

TYPE=INITIAL statement

This statement indicates the start of a parameter list build and is required. No other parameters are valid on a TYPE=INITIAL statement. The format of this statement is:

➤ DFSMDA — TYPE=INITIAL ➤

TYPE=CATDBDEF statement

This statement defines the dynamic allocation parameter list for the IMS catalog partition definition data set. This data set contains the definitions for the catalog HALDBs that are not defined in the DBRC RECON data set. The DD name of the catalog partition definition data set is DFSHDBSC.

➤ DFSMDA — TYPE=CATDBDEF,DBNAME= *dbname*,DSNAME= *dsname* ➤

DBNAME=

Specifies the DBD name of a Catalog database whose data sets are to be dynamically allocated. This name is used as a member name in IMS.SDFSRESL to identify this database parameter list.

DSNAME=

The name of the IMS catalog partition definition data set. The name can be any combination of simple and compound names that are valid in JCL, but cannot contain any special characters.

TYPE=CATDSHLQ statement

This statement defines the high level qualifier name to use when creating or allocating the system data sets of the IMS catalog. The system data sets of the IMS catalog include the IMS directory data sets, the bootstrap data set, and the staging data set.

➤ DFSMDA — TYPE=CATDSHLQ,DDNAME= *xxx*HLQ — ,SYSDSHLQ= *high_level_qualifier* ➤

DDNAME=

The alias name of the IMS catalog database to which the system data sets belong followed by the characters HLQ. For example, DDNAME=CAT1HLQ.

The *xxx* value that you specify on DDNAME must match the alias name for the IMS catalog that is defined on the ALIAS= parameter in the CATALOG section of the DFSDF*xxx* PROCLIB member.

SYSDSHLQ=

The high level qualifier name to use when creating or allocating the IMS catalog system data sets. The name can be any combination of simple and compound names that are valid in JCL, but cannot contain any special characters.

TYPE=DATABASE statement

This statement specifies the start of the definition for a database to participate in dynamic allocation and deallocation: one or more TYPE=DATASET statements should follow. (Do not use this statement for a DEDB area.) The format of the statement is:

►► DFSMDA — TYPE=DATABASE,DBNAME= *dbname* ◀◀

DBNAME=

Specifies the DBD name of a database whose data sets are to be dynamically allocated. This name is used as a member name in IMS.SDFSRESL to identify this database parameter list. Care should be taken to ensure that this name does not conflict with existing members in IMS.SDFSRESL. This includes, but is not limited to, IMS modules and user-supplied exit routines.

TYPE=DATASET statement

This statement defines either a data set within the database specified in the previous TYPE=DATABASE statement or a DEDB area. One complete TYPE=DATASET is used for each data set or area data set defined. Every data set within a database to be dynamically allocated and deallocated must be named in a TYPE=DATASET statement. When defining dynamic allocation of IMSACBA or IMSACBB, the TYPE=IMSACBA or TYPE=IMSACBB statement is followed by one or more TYPE=DATASET statements. When defining DEDB areas, a TYPE=FPDEDB statement must precede each TYPE=DATASET statement. If the data set within a database identifies a secondary index data set shared with another database, the DFSMDA members for the two databases must be generated in separate assemblies. The format of this statement is:

►► DFSMDA — TYPE=DATASET,DSNAME= *dsname*,DDNAME= *ddname* — ,DISP=  ◀◀

DSNAME=

Specifies the name of the data set. The name can be any combination of simple and compound names valid in JCL, except the name cannot contain special characters.

DDNAME=

Specifies the name of the DD statement defining this data set. This name is the same as that used in the DATASET or AREA statement of the DBDGEN.

For multiple ADSs, this name is the same as the ADDN name registered in the ADS RECON data set.

DISP=

Specifies the disposition of this data set when allocated. The default is OLD.

TYPE=DFSDCMON statement

Include one TYPE=DFSDCMON statement to define the dynamic allocation parameter list for the IMS Monitor data set. The format of this statement is:

►► DFSMDA — TYPE=DFSDCMON,DSNAME= *dsname*,DDNAME=IMSMON →

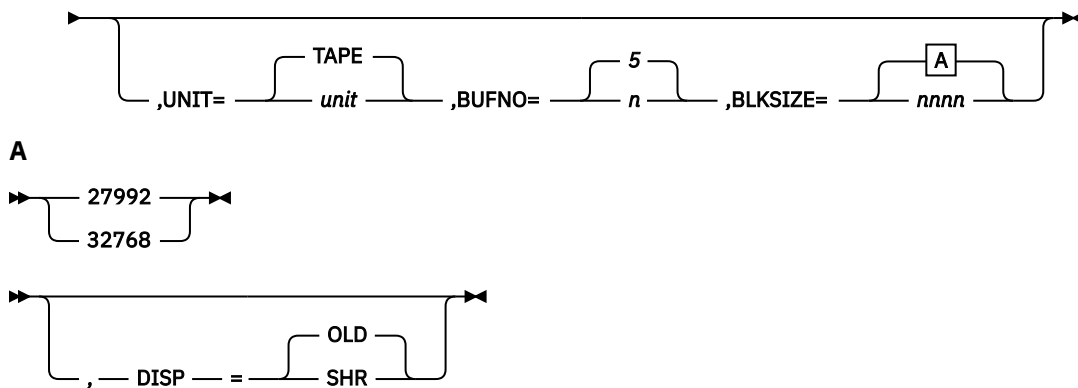

DSNAME=

Specifies the name of the data set, which must not be cataloged if the unit defines a TAPE device. However, if UNIT=DASD is specified, then the data set must be cataloged and available. The name

can be any combination of simple and compound names valid in JCL, but must not contain special characters.

DDNAME=IMSMON

Is the required value for DDNAME.

UNIT=

Specifies the unit for the DC Monitor data set. If the data set resides on a direct access device, UNIT=DASD must be specified and the data set must be cataloged. Otherwise, the value of UNIT= can be the name of any tape device valid to the installation. The default is UNIT=TAPE.

BUFNO=

Specifies the number of buffers for the IMS Monitor data set. Valid numbers range from 2 to:

- a maximum of 99 for DFP
- 255 for DFSMS

The default is 5.

Changes to BUFNO will not take effect until the next start of IMS. The initialization of these values is done only once after an IMS start.

BLKSIZE=

Specifies the block size for the IMS Monitor data set. For a tape device (UNIT≠DASD), the default is 32 KB. If UNIT=DASD, the default is 27 992.

Changes to BLKSIZE will not take effect until the next start of IMS. The initialization of these values is done only once after an IMS start.

DISP=

Specifies the disposition for the IMS Monitor data set for a UNIT=DASD data set definition. Valid values are OLD and SHR. OLD is the default if this parameter is not supplied. A warning message is issued if any other value is supplied, and a DISP=OLD value overrides the value specified.

TYPE=FPDEDB statement

This statement defines an area within a data entry database (DEDB). One TYPE=FPDEDB statement is required for each area to be specified. The format of this statement is:

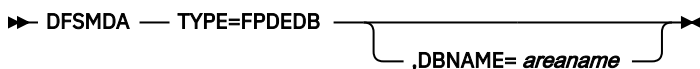

DBNAME=

Specifies the DBD name of the DEDB in which the specified area resides. This parameter is optional, and is used for documentation purposes only. For DEDB areas, the IMS.SDFSRESL parameter list is not named with the database name, but rather with the area's ddname.

TYPE=IMSACB statement

IMS uses the TYPE=IMSACB statement to dynamically create the staging library during the ACB library member online change process.

The HALDB alter function also uses dynamic allocation of the staging ACBLIB and requires that the staging ACBLIB be available throughout alter processing until the online change function completes the alter process.

The ACB library member online change function works only in an IMSplex environment, where the global online change process is supported. You can optionally include the IMSACB DD statement in the “[IMS procedure](#)” on page 639 rather than the DFSDMA macro to dynamically allocate the staging ACBLIB. See this topic for an overview of dynamically allocating the staging ACBLIB: “[Dynamically allocating the ACB staging library for ACBLIB member online change](#)” on page 145.

The format of this statement is:

►► DFSMDA — TYPE=IMSACB —————►
 └─ ,DSNAME= *dsname* ─┘

DSNAME=

Specifies the name of the data set. The name can be any combination of simple and compound names valid in JCL, except that it cannot contain special characters.

TYPE=IMSACBA statement

IMS uses the TYPE=IMSACBA statement to create the dynamic allocation member to allocate the IMS IMSACBA library data sets. Using DFSMDA to dynamically allocate IMSACBA allows you to resize the inactive ACBLIB data sets, add data sets to the concatenation, or change data sets in the concatenation without bringing IMS down. See the following topic for an overview of dynamically allocating the IMSACBA data set: [“Dynamically allocating the IMSACBA and IMSACBB library data sets” on page 146.](#)

The format of this statement is:

►► DFSMDA — TYPE=IMSACBA —►

The TYPE=IMSACBA statement is followed by one or more TYPE=DATASET statements.

Dynamic allocation statements for the IMSACBA and IMSACBB data sets can be combined in the same job. They cannot be combined with other statements to dynamically allocate any other IMS data set.

TYPE=IMSACBB statement

IMS uses the TYPE=IMSACBB statement to create the dynamic allocation member to allocate the IMS IMSACBB library data sets. Using DFSMDA to dynamically allocate IMSACBB allows you to resize the inactive ACBLIB data sets, add data sets to the concatenation, or change data sets in the concatenation without bringing IMS down. See the following topic for an overview of dynamically allocating the IMSACBB data set: [“Dynamically allocating the IMSACBA and IMSACBB library data sets” on page 146.](#)

The format of this statement is:

►► DFSMDA — TYPE=IMSACBB —►

The TYPE=IMSACBB statement is followed by one or more TYPE=DATASET statements.

Dynamic allocation statements for the IMSACBA and IMSACBB data sets can be combined in the same job. They cannot be combined with other statements to dynamically allocate any other IMS data set.

TYPE=OLCSTAT statement

This statement defines the dynamic allocation parameter list for the global online change OLCSTAT data set. The format of this statement is:

►► DFSMDA — TYPE=OLCSTAT,DSNAME= *dsname* —►

DSNAME

Specifies the name of the OLCSTAT data set. The name can be any combination of simple and compound names valid in JCL, except that it cannot contain special characters.

TYPE=OLDS statement

This statement defines the dynamic allocation parameter list for the online log data set (OLDS). There must be as many DFSMDA macros as there are OLDS.

Requirement: If you use dual logging, DFSMDA member names are required for both the primary and secondary OLDS.

The format of this statement is:

►► DFSMDA — TYPE=OLDS,DSNAME= *dsname*,DDNAME=DFSOL *xnn* —►

DSNAME=

Specifies the name of the data set. The name can be any combination of simple and compound names valid in JCL, except that it cannot contain special characters.

DDNAME=

Specifies the OLDSs to be allocated. If the OLDSs are dual, there must be a pair of macros, one with the ddname of the primary OLDS and the other with the ddname of the secondary OLDS (for example, DFSOLP01 and DFSOLS01). The data set must be cataloged. Substitute P for x when declaring a primary data set. Substitute S for x when declaring a secondary data set. Values from 00 through 99 can be specified for nn.

TYPE=RECON statement

This statement defines the dynamic allocation parameter list for database recovery control (DBRC). The format of this statement is:

►► DFSMDA — TYPE=RECON,DSNAME= *dsname*,DDNAME= *ddname*,WAIT=  ►►

DSNAME=

Specifies the name of the data set. The name can be any combination of simple and compound names valid in JCL, except that it cannot contain special characters.

DDNAME=

Specifies the name of the DD statement defining this data set. If an application uses alternate DD names for the RECON data sets, the dynamic allocation members must be created for the alternate DD names before the application can use these DD names.

WAIT=

If YES is specified on any of the TYPE=RECON statements, a wait is issued for any of the RECONS found to be offline during DBRC initialization. WAIT=NO is the default. Omitting the WAIT= parameter or specifying WAIT=NO causes dynamic allocation to fail if a RECON data set is offline during DBRC initialization.

TYPE=SLDS statement

This statement defines the dynamic allocation parameter list for the SLDS. SLDSs are dynamically allocated when required as input for restart. A single DFSMDA member with name IMSLOGR must be created to specify the UNIT information required for allocation. All SLDSs to be used as input to restart must reside on the same device type. The format of this statement is:

►► DFSMDA — TYPE=SLDS,UNIT= *device type*,DDNAME=IMSLOGR ►►

UNIT=

Specifies the device required for allocation. All SLDSs used as input for restart must reside on the same device type. This applies to both the primary and secondary data sets when dual logging is used. The device type can be tape or DASD.

DDNAME=IMSLOGR

Is the required value for DDNAME.

TYPE=TRACE statement

This statement defines the dynamic allocation parameter for external trace data sets. External trace data can be written to disk storage or to a tape unit. The statement differs with the type of storage chosen. The format of the statement for disk allocation is:

►► DFSMDA TYPE=TRACE,DDNAME=DFSTRA0n,DSNAME= *dsname* ►►

DDNAME

Specifies the ddname of the data set located on the disk. *n* specifies the number of the data set, and must be either 1 or 2. Each data set must be cataloged. Use two data sets to ensure that trace data is available at EOF.

DSNAME

Specifies the data set name. The name can be any combination of alphanumeric characters that is valid for IMS, except for special characters such as @, \$, or #. DSNAME can be up to 44 bytes long.

The format for data set allocation to tape is:

►► DFSMDA — TYPE=TRACE — ,DDNAME=DFSTRA0T — ,DSNAME= *dsname* →►

◀◀ ,UNIT= $\overbrace{\text{TAPE}}^{\text{TAPE}}$ *nnnn* ,BLKSIZE $\overbrace{20024}^{\text{20024}}$ *nnnnn* ▶▶

DDNAME

Specifies the ddname of the data set located on the tape. DFSTRA0T is the required ddname if you allocate the external trace data set to a tape.

DSNAME

Specifies the data set name. DSNAME must not be cataloged. The name and can be any combination of alphanumeric characters that is valid for IMS, except for special characters such as @, \$, or #. The name you specify can be up to 44 bytes long.

UNIT

Specifies the unit for the external trace data set. The unit must be a tape device, but can be any name valid to the installation. The default value is TAPE.

BLKSIZE

Is the block size of the external trace data set. The minimum value is 4008. Any other value chosen must be a multiple of 4004 (the LRECL) plus 4. The default is 16384.

Recommendation: Use a block size of 20 024 because it is 1/2 track.

Future DASD might change the track size, and older DASD might have different track sizes.

TYPE=WADS statement

This statement defines the dynamic allocation parameter list for the write ahead data set (WADS). There must be as many DFSMDA macros as there are WADS data sets. The DFSMDA member name must be the same as the ddname of the WADS that it defines.

Requirement: If dual logging is used, DFSMDA member names are required for both the primary and secondary WADS.

The format of this statement is:

►► DFSMDA — TYPE=WADS,DSNAME= *dsname*,DDNAME=DFSWADS *n* ▶▶

DSNAME=

Specifies the name of the data set. The name can be any combination of simple and compound names valid in JCL, except that it cannot contain special characters. The data set must be cataloged.

DDNAME=

Specifies the WADS to be allocated. Values 0 through 9 can be specified for n. When dual logging for the WADS is requested using the WADS=D execution time parameter, there must be at least two WADS provided.

TYPE=FINAL statement

This statement indicates the end of a parameter list build and is required. No other parameters are valid on a TYPE=FINAL statement. The format of this statement is:

►► DFSMDA — TYPE=FINAL ▶▶

JCL examples

The examples in this topic contain the following comment line above the SYSIN statement, for reference only, to aid in column alignment.

```
/* +----1----+----2----+----3----+----4----+----5----+----6----+----7---
```

Example 1: Specify three databases and the IMS Monitor data set to participate in dynamic allocation and deallocation.

```
//DALOC    JOB
//*
//STEP     EXEC IMSDALOC
//* +----1----+----2----+----3----+----4----+----5----+----6----+----7---
//SYSIN    DD *
DFSMDA TYPE=INITIAL
DFSMDA TYPE=DATABASE, DBNAME=DI41M101
DFSMDA TYPE=DATASET, DSNAME=IMSQA.M1I3I1, DDNAME=M1I3I1
DFSMDA TYPE=DATASET, DSNAME=IMSQA.M1I301, DDNAME=M1I301
DFSMDA TYPE=DATABASE, DBNAME=DX41SK03
DFSMDA TYPE=DATASET, DSNAME=IMSQA.DB5H111, DDNAME=DXSK0301,           X
        DISP=SHR
DFSMDA TYPE=DATASET, DSNAME=IMSQA.DB5H222, DDNAME=DXSK0302,           X
        DISP=SHR
DFSMDA TYPE=DATASET, DSNAME=IMSQA.DB5H333, DDNAME=DHSK0301,           X
        DISP=SHR
DFSMDA TYPE=DATABASE, DBNAME=DH41SK03
DFSMDA TYPE=DATASET, DSNAME=IMSQA.DB4D111, DDNAME=DDSK0101,           X
        DISP=SHR
DFSMDA TYPE=DATASET, DSNAME=IMSQA.DB4D222, DDNAME=DDSK0102,           X
        DISP=SHR
DFSMDA TYPE=DFSDCMON, DDNAME=IMSMON, DSNAME=I115T237.IMSMON
DFSMDA TYPE=FINAL
END
/*
```

Example 2: Specify three DEDB areas to participate in dynamic allocation and deallocation

```
//DALOC    JOB
//*
//STEP     EXEC IMSDALOC
//* +----1----+----2----+----3----+----4----+----5----+----6----+----7---
//SYSIN    DD *
DFSMDA TYPE=INITIAL
DFSMDA TYPE=FPDEDB, DD41SK02
DFSMDA TYPE=DATASET, DSNAME=DB9AREA0, DDNAME=DB9AREA0
DFSMDA TYPE=FPDEDB
DFSMDA TYPE=DATASET, DSNAME=DB22AR0, DDNAME=DB22AR0,                   X
        DISP=SHR
DFSMDA TYPE=FPDEDB, DEDBJN22
DFSMDA TYPE=DATASET, DSNAME=DB22AR1, DDNAME=DB22AR1,                   X
        DISP=OLD
DFSMDA TYPE=FINAL
END
/*
```

Example 3: Specify the JCL and macro statements for SLDS to participate in dynamic allocation and reallocation

```
//ASSEMBLY EXEC IMSDALOC
//*
//SYSLIB   DD DSN=RNC.SDFSMAC, DISP=SHR
//         DD DSN=I130TS13.SDFSMAC, DISP=SHR
//         DD DSN=IMS.&SYS2.SDFSMAC, DISP=SHR
//* +----1----+----2----+----3----+----4----+----5----+----6----+----7---
//SYSIN    DD *
DFSMDA TYPE=INITIAL
DFSMDA TYPE=SLDS, UNIT=SYSDA, DDNAME=IMSLOGR
DFSMDA TYPE=FINAL
END
/*
//LNKEDT.SYSLMOD DD DSNAME=IMSQA.TNUC2, DISP=SHR,
//              UNIT=SYSDA, VOL=SER=USER01
```

Example 4: Build allocation members for RECON data sets RECON1, RCONSS, and RCONPW, and to trace data sets on DASD

```
//DYNALL JOB
//*
//STEP EXEC IMSDALOC
//SYSIN DD *
DFSMDA TYPE=INITIAL
DFSMDA TYPE=RECON,DSNAME=IMSV41.RECON01,DDNAME=RECON1,WAIT=YES
DFSMDA TYPE=RECON,DSNAME=IMSV41.RECON02,DDNAME=RCONSS,WAIT=YES
DFSMDA TYPE=RECON,DSNAME=IMSV41.RECON03,DDNAME=RCONPW,WAIT=YES
DFSMDA TYPE=TRACE,DDNAME=DFSTRA01,DSN=IMS41.DFSTRA01
DFSMDA TYPE=TRACE,DDNAME=DFSTRA02,DSN=IMS41.DFSTRA02
DFSMDA TYPE=FINAL
END
/*
```

Example 5: Build allocation members for RECON data sets and to trace data sets on tape

```
//DYNALL JOB
//*
//STEP EXEC IMSDALOC
//SYSIN DD *
DFSMDA TYPE=INITIAL
DFSMDA TYPE=RECON,DSNAME=IMSV41.RECON01,DDNAME=RECON1,WAIT=YES
DFSMDA TYPE=RECON,DSNAME=IMSV41.RECON02,DDNAME=RECON2,WAIT=YES
DFSMDA TYPE=RECON,DSNAME=IMSV41.RECON03,DDNAME=RECON3,WAIT=YES
DFSMDA TYPE=TRACE,DDNAME=DFSTRA0T,DSNAME=TAPEDS1,UNIT=TAPE,BLKSIZE=20024
DFSMDA TYPE=FINAL
END
/*
```

Example 6: Define three data sets in the IMSACBA concatenation

```
//DYNALL JOB
//*
//STEP EXEC IMSDALOC
//SYSIN DD *
DFSMDA TYPE=INITIAL
DFSMDA TYPE=IMSACBA
DFSMDA TYPE=DATASET,DSNAME=IMS.ACBLIB1
DFSMDA TYPE=DATASET,DSNAME=IMS.ACBLIB2
DFSMDA TYPE=DATASET,DSNAME=IMS.ACBLIB3
DFSMDA TYPE=FINAL
END
/*
```

Example 7: Define three data sets in the IMSACBB concatenation

```
//DYNALL JOB
//*
//STEP EXEC IMSDALOC
//SYSIN DD *
DFSMDA TYPE=INITIAL
DFSMDA TYPE=IMSACBB
DFSMDA TYPE=DATASET,DSNAME=IMS.ACBLIB4
DFSMDA TYPE=DATASET,DSNAME=IMS.ACBLIB5
DFSMDA TYPE=DATASET,DSNAME=IMS.ACBLIB6
DFSMDA TYPE=FINAL
END
/*
```

Example 8: Define a DFSMDA member for the IMS catalog DBD

The following sample JCL defines a DFSMDA member for the catalog DBD. Replace *dsn* with a name of your choice.

```
//*
//STEP EXEC IMSDALOC
/* +---1---+---2---+---3---+---4---+---5---+---6---+---7---
//SYSIN DD *
DFSMDA TYPE=INITIAL
DFSMDA TYPE=CATDBDEF,DSNAME=dsn
DFSMDA TYPE=FINAL
```

```
END
/*
```

Restrictions

The following restrictions apply when using the Dynamic Allocation macro:

- HALDBs are dynamically allocated and do not need the Dynamic Allocation macro.
- If you are going to dynamically allocate a database, all DD statements referenced in the DMB for the database must be defined in the TYPE=DATASET, DDNAME= parameter. A database cannot be partially allocated by JCL and partially allocated by a dynamic allocate member.
- Because dynamic allocation cannot resolve logical relationships between DBDs, you must define a dynamic allocation member for each DBD in a logically related database. For example, a HIDAM database is composed of two logically related DBDs, the index DBD and the data area DBD. Each DBD in this example must have a dynamic allocation member with the same name as the DBD.
- The Batch Backout utility (DFSBB000) is the only IMS utility that is supported for dynamic allocation.
- A database that is generated as a DFSMDA member cannot be given a name that is a duplicate of any label name that is generated during the assembly step of the DFSMDA job. IMS generates a label using the database name during this step, and an error occurs if that label name exists in code invoked by DFSMDA. This restriction does not apply to data set names.
- A database that is generated as a DFSMDA member cannot be defined with a ddname that is identical to the ddname defined for another database during the same assembly step of the DFSMDA job. If more than one database must be defined with the same ddname (as in the case of secondary indexes), the DFSMDA job must be run separately for each required occurrence of the ddname.
- Unless it is a dynamic allocation member, no member that has the same name as a database should be bound into IMS.SDFSRESL.

FPCTRL macro

The FPCTRL macro is ignored during system definition; however, you can include it for compatibility purposes.

To activate Fast Path, use the Fast Path parameter (FP=Y|N) on the IMS procedure. All values previously supported by FPCTRL are supported parameters on the IMS procedure.

Related Reading: See [“IMS procedure”](#) on page 639 for more information.

IMSCTRL macro

Use the IMSCTRL macro statement to describe the basic IMS control program options, the z/OS system configuration under which IMS is to execute, and the type and class of IMS system definition to be performed.

The IMSCTRL macro is required. This macro instruction must be the first statement of the system definition control statements that are entered into the system definition stage 1 for an IMS or a DBCTL system. You can have only one IMSCTRL macro instruction within an IMS system definition.

The only other macro instruction required for a batch environment is IMSGEN.

Important: If you run stage 1 and stage 2 processing using the IMSCTRL macro without specifying MODBLKS, a cold start is required. Failing to specify MODBLKS causes the IMS.SDFSRESL data set to be updated and copied, which requires you to perform a cold start.

- [“Dynamic definition”](#) on page 428
- [“Supported environments”](#) on page 428
- [“Syntax”](#) on page 429
- [“Positional parameters”](#) on page 430

- [“Keyword parameters” on page 430](#)

Dynamic definition

The IMS control region cannot be dynamically defined. However, you can export the MODBLKS resource definitions that are generated by the environment created using this IMSCTRL macro for subsequent dynamic definition of applications, databases, transactions, and routing codes.

Supported environments

The IMSCTRL macro must be the first macro defined in the DB/DC, DBCTL, and DCCTL environments.

Syntax

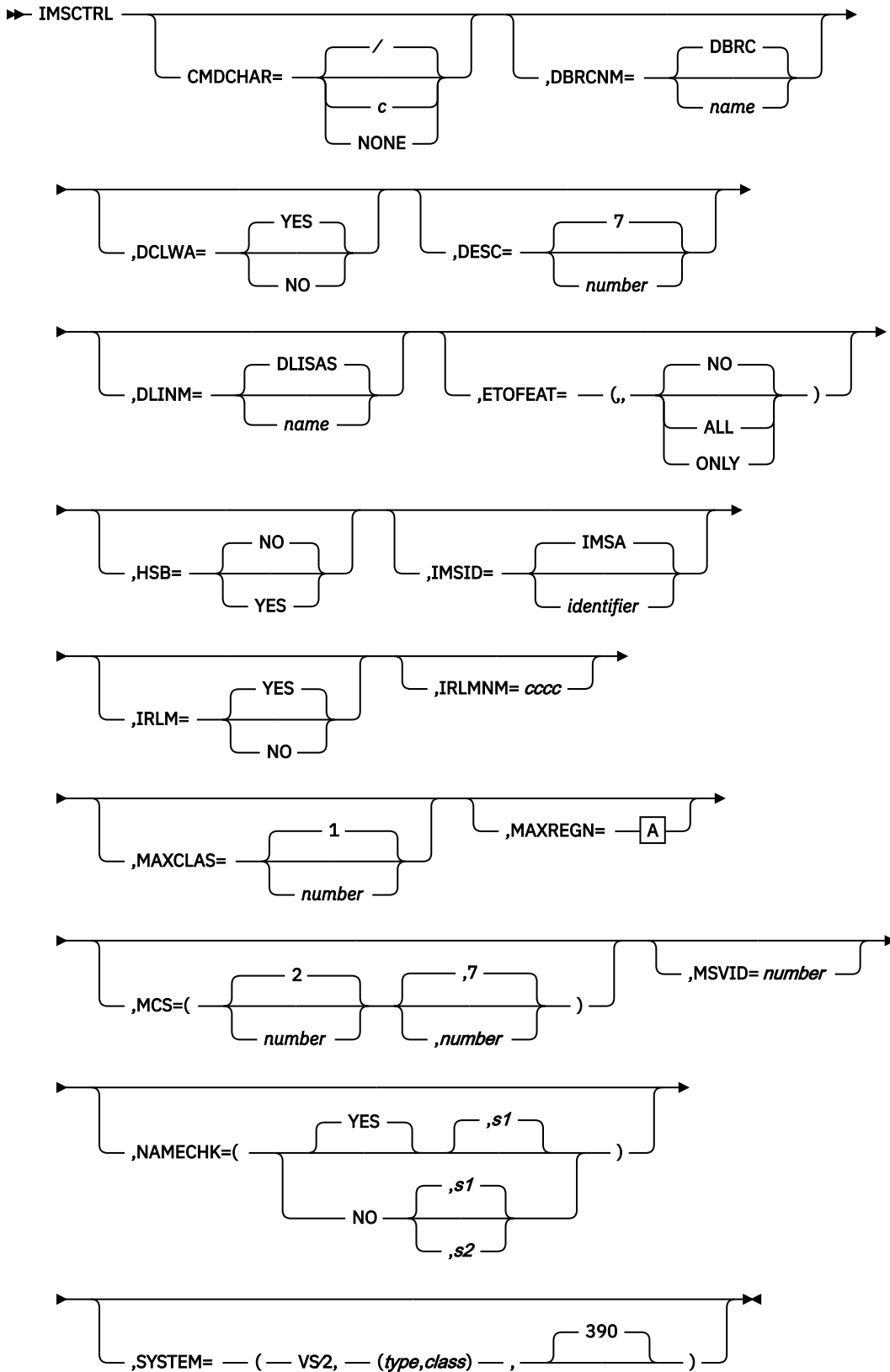

A

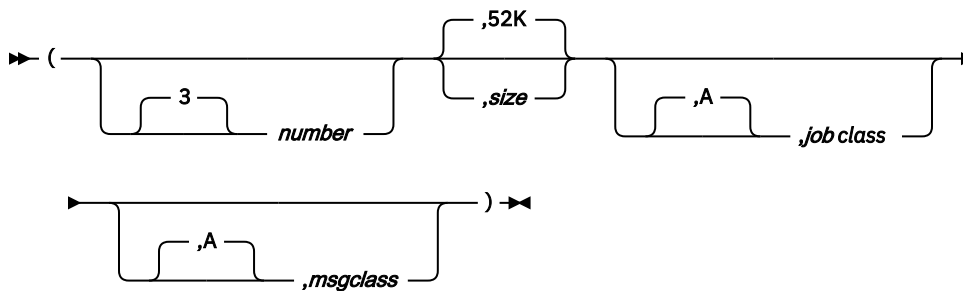

Positional parameters

The IMSCTRL macro does not include positional parameters.

Keyword parameters

To find which parameters apply to your IMS configuration, refer to [“Selecting the appropriate macros to define your system”](#) on page 5.

CMDCHAR=

/

The default value.

c

Any character except comma (,), less than (<), or greater than (>). Ampersand (&) must be entered as && to define it as the command character.

NONE

No command recognition character (CRC) is defined.

CMDCHAR can be specified for DBCTL, DB/DC, or DCCTL. The value of CMDCHAR can be specified at execution time by specifying execution parameter CRC=.

With a DBCTL system, CMDCHAR specifies the command recognition character used by the MTO to enter IMS commands for this DBCTL environment. If CMDCHAR=NONE is specified and the CRC is not specified as an execution parameter (CRC=), then commands are entered for this DBCTL system with a prefix of the IMSID.

DB/DC and DCCTL systems allow commands to be entered at MCS/E-MCS consoles with a CRC prefix by specifying execution parameter keyword CMDMCS with a value other than N.

The CRC can be specified with CMDCHAR or with CRC at execution time.

If CMDCHAR=NONE is specified and the CRC is not specified as an execution parameter (CRC=), commands are entered for the DB/DC or DCCTL system with a prefix of the IMSID.

Although other products and subsystems might use certain command recognition characters, the CRC is not required to be unique among all IMS systems. Choose an unreserved character that is appropriate for your particular system.

Do not use a character for the CRC that is the same as the beginning character of a z/OS command. If the CRC is the same as the beginning character of a z/OS command, that command does not work after you start IMS. For example, if you start IMS with CRC=D, z/OS does not respond to any of the z/OS display commands such as D A, L.

The CRC value you select might affect multisegment command processing. The last character of the command is checked during multisegment command processing. If that character matches the CRC, the command is assumed to be a multisegment command. Processing of the command waits for the rest of the command. For example, if you use B for the command recognition character, and issue the command BMODIFY PREPARE ACBLIB, the command does not run. The ending 'B' in 'ACBLIB' is interpreted to indicate a multisegment command. To enter this command correctly, enter:

```
'BMODIFY PREPARE ACBLIB. '
```

The character you choose for a DB/DC system becomes the command recognition for the IMS system. If your installation allows commands from MCS or E-MCS consoles, you need a CRC only if both of the following statements are true:

- IMS provides DBCTL service to a CCTL.
- CCTL broadcasts an IMS SWITCH command preceded by a CRC.

CMDCHAR does not affect the normal DB/DC MTO's use of the / character when entering IMS commands.

DBRC=

The system definition process ignores this parameter, though for compatibility purposes, it can still be coded.

DBRCNM=

Specifies for z/OS the IMS.PROCLIB member containing the skeletal procedure for the DBRC address space. The IMS control region automatically initiates the DBRC address space, using the z/OS start command and specifying this name. To rebuild the DBRC procedure, you must use the IMS.PROCLIB member containing the skeletal procedure for the DBRC address space. This procedure can be obtained from IMS.SDFSPROC data set and contains the name you specify in stage 1.

Consequently, the DBRC procedure must be copied from IMS.PROCLIB to SYS1.PROCLIB. For more information, see [“Making IMS and IMSRDR procedures accessible to z/OS” on page 210.](#)

You can specify up to an eight-character name, the first character being alphabetic. The default name is DBRC.

Specifying DBRCNM=xxxxxxx results in the following:

A DBRC address space cataloged procedure is created with the name xxxxxxxx.

To make the DBRC address space cataloged procedure name of xxxxxxxx operational, the following must be true:

A DBRC address space must be cataloged as xxxxxxxx in SYS1.PROCLIB.

Simply specifying DBRCNM=xxxxxxx in your IMS system definition is not sufficient.

DCLWA=

Establishes a default value that IMS applies to any transactions defined by subsequent TRANSACT macro statements. DCLWA= specifies whether (YES) or not (NO) IMS should perform log write-ahead for recoverable nonresponse-mode input messages and transaction output messages. The default is YES. If no value is specified for DCLWA= on the IMSCTRL macro, the value for DCLWA= on any subsequent TRANSACT macros accepts the default of YES, or you can specify YES or NO on the individual TRANSACT macros.

Specify or accept the default of YES to ensure that:

- A nonresponse-input transaction is made recoverable across IMS failures, before IMS acknowledging receipt of the input.
- Database changes are made recoverable before IMS sending associated output reply messages.

YES ensures that information in the log buffers is written to the IMS log before the associated input acknowledgment or output reply is sent to the terminal.

Specify or accept the default of YES for all VTAM terminal types.

Specify NO if input message integrity and the consistency of output messages with associated database updates is not required. DCLWA does not apply to response mode or Fast Path input processing, and, if specified in these situations, is ignored during IMS execution.

DESC=

Specifies the message descriptor codes to be assigned to the IMS system console messages if MCS support is included in the z/OS system definition. You can specify up to 16 values. If DESC is not specified, the default value is 7.

The IMS MCS= and DESC= keywords should be defined as is required for the ROUTCDE and DESC keywords of the z/OS WTO macro.

DLINM=

Specifies for z/OS the IMS.PROCLIB member to contain the skeletal procedure for the optional DL/I address space. The IMS control region automatically initiates the DL/I address space using the z/OS start command and specifying this name.

Consequently, the DL/I procedure must be copied from IMS.PROCLIB to SYS1.PROCLIB. You probably need to modify the skeletal procedure. This procedure can be obtained from IMS.SDFSPROC data set.

For more information, refer to "Member Name DLISAS" in ["Environments that support IMS.SDFSRESL procedures"](#) on page 518.

You can specify up to an eight-character name, the first character being alphabetic. The default name is DLISAS.

Specifying DLINM=xxxxxxx results in the following:

A DL/I address space cataloged procedure is created with the name xxxxxxx.

ETOFEAT=

Specifies whether the system definition process should build ETO descriptors. The default is not to build the ETO descriptors.

The first two parameters of the ETOFEAT keyword are no longer valid and are ignored if specified. Commas appear in place of these parameters in the syntax diagram.

The third parameter indicates whether the system definition process should produce ETO descriptors only (ONLY), produce descriptors along with a normal system definition (ALL), or produce a normal system definition without descriptors (NO). The default is NO.

If you have not installed ETO, the ETO option is forced off.

HSB=

Specifies whether or not an XRF-capable system is generated. The default is NO.

If you specify NO, an XRF-capable system is not generated.

If you specify YES, an XRF-capable system is generated and ISC has duplexed blocks. If you plan to run XRF or an alternate subsystem before the next planned cold start of IMS, specify HSB=YES on the IMSCTRL macro to eliminate the need for a subsequent IMS system definition and cold start.

XRF is disabled if no value is specified for HSBID in the DFSPBIMS or DFSPBDCC members, or in the IMS execution JCL. Informational message DFS3899I is issued.

IMSID=

Specifies a one- to four-character alphanumeric identifier for the IMS system.

For IMS control region: Specifies a one- to four-character identifier that is a valid subsystem identifier to the operating system being used. It can be overridden by the IMSID= keyword specified in the startup procedures.

For IMS dependent regions: Specifies a one- to four-character identifier that is a valid subsystem identifier to the operating system to which this dependent region connects. It can be overridden by the IMSID= keyword specified in the startup procedures.

For IMS batch region: Specifies a one- to four-character IMS identifier that is used in IMS messages that are written to the system log. It can be overridden by the IMSID= keyword specified in the startup procedures.

Recommendation: Specify a unique IMSID for each batch region. This helps to avoid confusion as to which region has issued a console message.

Do not use characters for the IMSID that match the beginning characters of a z/OS command. If the IMSID is the same as the beginning characters of a z/OS command, that command does not work after you start IMS. For example, if you start IMS with IMSID=D, z/OS does not respond to any of the z/OS display commands such as D A, L.

For online control regions, the IMSID must be different from any other IMS subsystem identifier or non-IMS subsystem identifier defined to the operating system under which IMS is running. This identifier is also used to relate messages that are routed to the z/OS system console with the corresponding IMS system. To avoid confusion as to which region has issued a console message, specify a unique IMSID for each batch region. This is however, not a requirement.

The IMSID name must not be the same as the procedure name that starts IMS unless one of the following is true:

- All DD statements in the startup procedure are cataloged in the master catalog.
- The unit and volume are specified on each DD statement.

IRLM=

IRLM=NO specifies that the IRLM is not used by online or batch systems unless overridden at execution time.

IRLM=YES specifies that the IRLM is used by online and batch systems unless overridden at execution time.

If the IRLM= parameter is omitted, and IRLMNM= is specified, the IRLM default is set to YES, but can be overridden by the IRLM=N parameter at execution time.

If the both the IRLM= parameter and the IRLMNM= parameter are omitted, the IRLM default is set to NO but can be overridden at execution time. If it is overridden at execution time, a default value of IRLM is used for the IRLMNM= parameter.

If the IRLMNM= parameter is omitted and the IRLM= parameter is specified, a warning assembly error message is issued stating that the IRLM= parameter is invalid, and NULL is assumed. A default value of IRLM is used for the IRLMNM= parameter if IRLM=Y is specified in the execution JCL.

IRLMNM=

Specifies a one- to four-character alphanumeric name assigned to the Internal Resource Lock Manager (IRLM) included in your system.

If the IRLMNM= parameter is not specified, the IRLM is not invoked by batch or online systems by default. To invoke the use of the IRLM by a batch or online system, you must code IRLM=Y in the execution JCL.

When the IRLMNM= parameter is not specified in the IMSCTRL macro or in the execution JCL, and IRLM=Y is specified in the execution JCL, the IRLM name that is used is IRLM.

The IRLM must be active in your system if your IMS system is to share data at the block level with other IMS systems. The IRLM is optional for systems that do not share data at the block level.

Only one IRLM can be specified for any IMS system (and thus, only one IRLMNM), but multiple IRLMs can exist within a particular z/OS system. Each IRLM must be defined as a z/OS subsystem.

The name specified on this IRLMNM= parameter must be the z/OS subsystem name assigned to the IRLM with which this IMS system is to connect. If IMS is connected to an executing copy of IRLM, Db2 for z/OS cannot connect to it. If Db2 for z/OS is connected to an executing copy of IRLM, IMS cannot connect to it.

If this parameter is specified and not overridden with the IRLM=NO parameter on the online or batch startup procedures, IMS only completes initialization if the named IRLM is available at execution time. Also, IMS uses the named IRLM for all locking services, both local and sharing. Program isolation locking is not used.

It is important to understand the interaction of this IRLMNM parameter with the DBRC parameter and with the ACCESS parameter on the DATABASE macro statement.

MAXCLAS=

Specifies the range of active (started) classes after IMS initialization. Valid values are decimal numbers from 1 to 999. The default is 1. Any transaction code class specified on either the APPLCTN or TRANSACT macro statement must not exceed this value. If the class is not active at the time of scheduling, the schedule request is treated as if the class were stopped.

MAXIO=

Is no longer used. If MAXIO is specified the value is ignored.

MAXREGN=

Specifies the maximum number of IMS control block sets that are permanently allocated. A control block set is required for each dependent region type (batch message processing, message processing, or CCTL threads) that can be started. (Note that this does not imply that the same number of dependent regions are always active.)

This value must be a decimal number from 1 through 999. When the count of dependent regions started exceeds the value specified by the MAXREGN= parameter, control block sets are dynamically allocated, but the storage for these sets is released as the dependent regions terminate. The default is 3.

The second through fourth fields specify region size (default value is 52 KB), region job class (default class is A), and job message class (default class is A).

Region size (which must be expressed in terms of xxK), region job class, and job message class must conform to the operating system JCL specifications. This operand is ignored for BATCH system definitions.

MCS=

Specifies the z/OS routing code to be assigned to the IMS system console if multiple console support (MCS) is included in the operating system. If MCS is not specified, the default is (2,7).

Although z/OS supports more than 16 route codes, IMS uses only route codes 1 through 16.

In a DBCTL environment, MCS= defines which consoles are to receive unsolicited DBCTL messages.

MSVID=

Specifies a one- to three-digit decimal number 1 - 676 that is used to complete the eight-character name of the generated IMS Multiple Systems Verification utility control blocks module generated for this system (DFSMSxxx). If fewer than three decimal digits are specified, the value is right-justified and filled to the left with zeros. (For example, specifying 3 creates the name DFSMS003.)

This control blocks module is assembled and bound during IMS system definition stage 2 processing. The Multiple Systems Verification utility procedure (IMSMSV) is, as the user directs, placed into the IMS.PROCLIB data set.

The MSVID= keyword:

- Is applicable only to resources in the IMS.MODBLKS data set that are defined by system definition.
- Is required when MSVERIFY is specified in the SYSTEM keyword.
- Is ignored if no multiple systems definition statements are present.
- Is ignored for DBCTL.
- Must be present to generate the IMS Multiple Systems Verification utility control blocks and procedure.

The MSC Verify utility (DFSUMSV0) can verify resources defined by system definition. It cannot verify resources defined dynamically, because those resources are no longer in MODBLKS. However, you can use the /MSVERIFY command to verify resources that are defined dynamically.

The specification of MSVID on the IMSCTRL macro statement is not related to the specification of SYSID on the MSNAME macro statement.

NAMECHK=

Specifies whether (YES) or not (NO) resource name checking and cross-checking are to be performed, and, if NAMECHK=NO, whether sorting is to be performed in stage 1 (S1) or stage 2 (S2).

If duplicate resource name checking and resource name cross-checking are performed (that is, NAMECHK is specified as or uses the default of YES), sorting must be performed in stage 1 (S1 specified or used by default). If resource name checking is to be bypassed, sorting can occur in either stage 1 (S1 specified or by default) or stage 2 (S2 specified).

It is suggested that you use the default values for NAMECHK unless:

- You have run the preprocessor before your stage 1 run and you want to omit resource name checking here (by specifying NAMECHK=NO).
- You have a specific performance reason for having IMS sort in stage 2 (for example, you generally run stage 1 multiple times per stage 2).

Related reading: For information about the options available to you by including or omitting the preprocessor in combination with options on the NAMECHK parameter, see [“Verifying the stage 1 input” on page 21.](#)

SYSTEM=

Specifies the operating system configuration and the type of IMS system definition to be performed.

The first SYSTEM= parameter must be VS/2, indicating the operating system is z/OS.

The second SYSTEM= parameter consists of two subparameters. The first subparameter defines *type* of system definition. The definition types are: ALL, BATCH, CTLBLKS, MODBLKS, MSVERIFY, NUCLEUS, and ON-LINE.

The second SYSTEM= subparameter defines the system definition environment *class*. The three system definition environment classes are:

DB/DC

Builds a standards IMS system. DB/DC is the default.

DBCTL

Builds only the DBCTL environment.

DCCTL

Builds only the DCCTL environment.

If you do not specify DBCTL on the second subparameter, the following functions are always included:

- All enhanced security codes and commands
- All MFS code, commands, procedures, and default formats
- VTAM code and commands, whenever VTAM is requested

The MFS format library is a required data set (regardless of whether MFS is used), except for DBCTL systems.

The MSVERIFY,DBCTL type/class combination is invalid. An error message is generated for invalid combinations.

The third SYSTEM= parameter indicates the operating system; the default is 390 (z/OS).

When you first install IMS, you must perform a full system definition. Thereafter, you can perform a subset of the full system definition to add or change a function. The parameters used in these subset system definitions are described in this section.

The SMP JCLIN process should be run after the stage 1 of all definition types.

ALL

Combines the BATCH and ON-LINE options.

BATCH

Moves required modules from the IMS distribution libraries to the user's libraries; it also generates system procedures and a database system.

A BATCH definition should not be run to add maintenance or to add or delete database functions or features to a residence library that contains a nucleus with the Data Communication feature.

CTLBLKS

Generates control block modules of all IMS control blocks for use within an IMS nucleus in the IMS control program region. The blocks built in the MODBLKS option are also included in this definition. This subparameter should be specified to replace the control blocks of an existing nucleus. If you are performing a CTLBLKS definition, the new nucleus must have the same suffix as the old nucleus. SMP maintenance integrity is lost if you rename the nucleus before using it in a CTLBLKS definition because SMP does not recognize the contents of the renamed nucleus. To change the control blocks in an existing nucleus, do a CTLBLKS definition. To generate a new nucleus, do a NUCLEUS definition.

The SMP JCLIN process should be run after the stage 1 of a CTLBLKS definition.

A CTLBLKS specification generates the MSC Verification Utility control blocks, if MSC definitions are present. When you specify CTLBLKS, you need not perform a separate system definition with MSVERIFY.

If any device or option is to be deleted during a CTLBLKS definition, unresolved references may exist when the nucleus is bound. This can also happen if logical terminal names are added or deleted before the occurrence of master or secondary master logical terminal names.

MODBLKS

Generates the control blocks members for resources to be added or changed online. These control blocks are used by the IMS control region and the Multiple Systems Coupling Verification utility.

The MODBLKS system definition requires that the stage 1 input contains all source statements for the existing system to which the online changes are to be made, except for communication specifications. If you use the Multiple Systems Coupling MSVERIFY utility, **all** source statements, including communication specifications, are required input to your stage 1 run. However, if communication specifications are omitted from a MODBLKS system definition, the following stage 1 error checking is not performed:

- Transaction names are not cross-checked against LTERM names to locate duplicates.
- For MSC users, the remote system ID (SYSID) on the TRANSACT macro statement is not checked against the remote system ID (SYSID) on the MSNAME macro statement to ensure that they are not duplicates.

Thus, omitting communication statements can result in undetected system definition errors. You must therefore consider your requirements for improved stage 1 performance against the possibility of undetected errors in your stage 1 input to determine whether you want to include or omit communication statements from your MODBLKS system definition input.

Only APPLCTN, DATABASE, TRANSACT, and RTCODE statements can be added, deleted, or modified. The restrictions pertaining to these modifications are found in the descriptions of these macro statements. IMS does not enforce these restrictions; rather, you are responsible for adhering to the directions provided there.

The effects of a MODBLKS system definition are made known to the IMS online system with a master terminal operator /MODIFY command sequence.

Stage 2 assembler output for a MODBLKS system definition is placed in IMS.OBJDSET. Binder output for the control blocks members affected by running an online change is placed in IMS.MODBLKS.

Certain types of changes, when made across a MODBLKS system definition, do not affect an existing resource except across a cold start. That is, the effects of prior commands are not negated by online change procedures. For example, resources that have been modified by commands such as /START, /STOP, /ASSIGN, /MSASSIGN are not altered, nor are resources whose status has been altered because of changes in the operating configuration (for example, a resource stopped because of an error condition).

Important: If you run stage 1 and stage 2 processing using the IMSCTRL macro without specifying MODBLKS, a cold start is required. Failing to specify MODBLKS causes updates to IMS.SDFSRESL, which requires the new IMS.SDFSRESL to be copied and, therefore, a cold start.

MSVERIFY

Generates a subset of the online control blocks required for execution in a multiple-IMS system configuration. MSVERIFY also generates the bind JCL and control statements required to place the Multiple Systems Verification utility into the IMS.SDFSRESL data set. This subparameter should be specified to generate a test system to verify, before attempting online execution, the consistency of definitions in an MSC configuration. This keyword causes an assembly error if the multiple systems definition statements are not present. If MSVERIFY is specified, MSVID is required.

NUCLEUS

Generates an IMS nucleus for the IMS control program region and control block modules for all IMS control blocks. This subparameter should be specified when generating an alternate nucleus that includes new or deleted old system features, such as additional terminal support or conversational support. A NUCLEUS specification generates the MSC Verification utility control blocks if MSC definitions are present. If NUCLEUS is specified, you do not need to perform a separate system definition, with MSVERIFY specified, to obtain the blocks.

To change the control blocks in an existing nucleus, do a CTLBLKS definition. To generate a new nucleus, do a NUCLEUS definition.

The SMP JCLIN process should be run after the stage 1 of all definition types.

ON-LINE

Moves required modules from the IMS distribution libraries to the user's libraries, generates system procedures, and generates those modules that contain the CTLBLKS and NUCLEUS options for an IMS system. It generates the assembler language and bind statements for all operating systems and VTAM-sensitive modules that are supplied in source form.

You must specify ON-LINE with the hyphen.

Usage information

Guidance information is provided to help you select the CTLBLKS, NUCLEUS, ON-LINE, or MODBLKS system definition type to use when modifying an existing ALL type of system definition. The guidelines can help you determine whether modification of parameters at execution can preclude the need for a new system definition.

Sample IMSCTRL macro JCL

The JCL below is an example of the IMSCTRL macro with:

- Three message regions
- Message region job class A (default)
- Job message class C
- Online and batch

```
IMSCTRL SYSTEM=(VS/2,(ALL,DB/DC),390), X  
MAXREGN=(3,52K,,C)
```

IMSGEN macro

Use the IMSGEN macro to specify the assembler and binder data sets and options, and the system definition output options and features.

IMSGEN must be the last IMS system definition macro in the stage 1 input stream, and it must be followed by an assembler END statement.

- [“Dynamic definition” on page 438](#)
- [“Supported environments” on page 438](#)
- [“Syntax” on page 438](#)
- [“Positional parameters” on page 441](#)
- [“Keyword parameters” on page 441](#)

- [“IMSGEN macro statement - example 1” on page 447](#)
- [“IMSGEN macro statement - example 2” on page 448](#)

Dynamic definition

Assembler and binder data sets and options cannot be dynamically defined.

Supported environments

The IMSGEN macro can be used in the DB/DC, DBCTL, and DCCTL environments.

Syntax

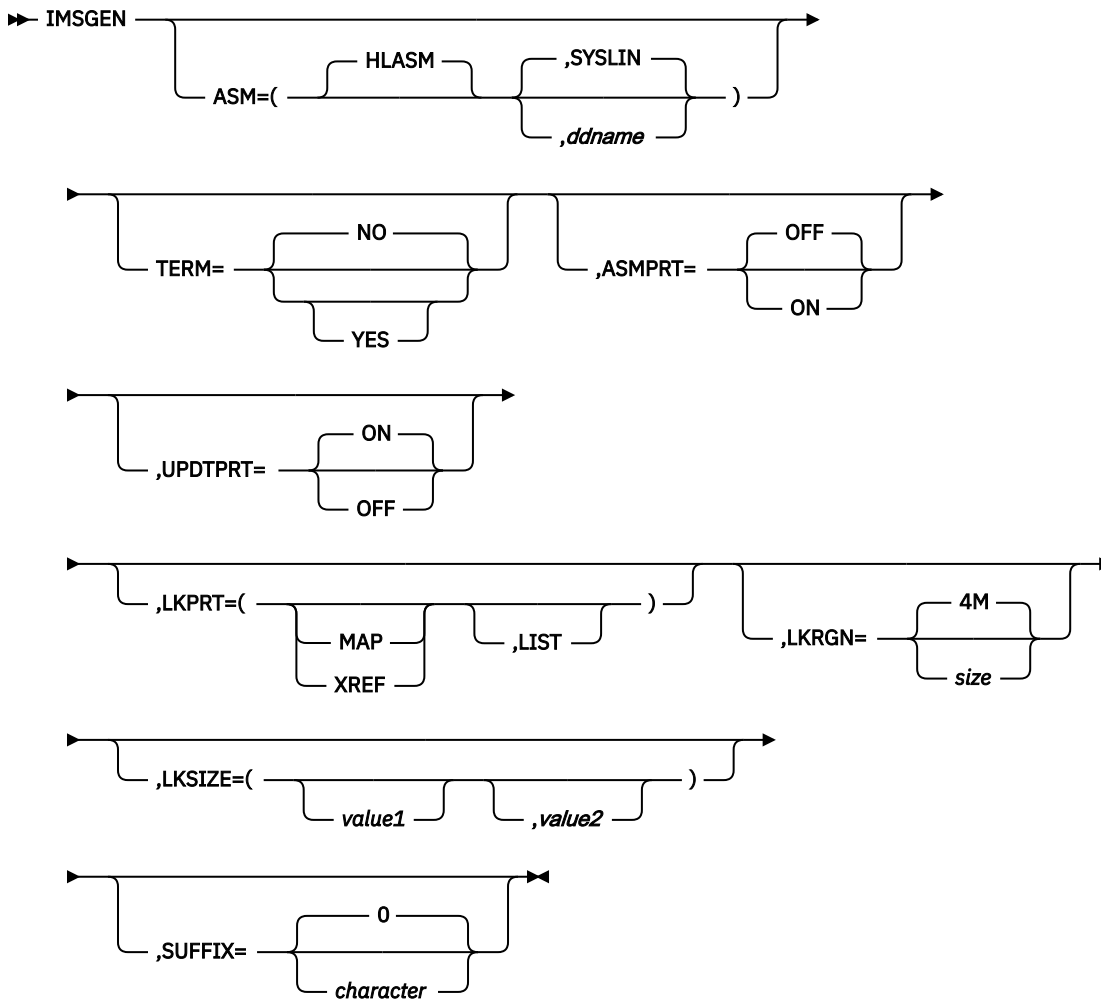

IMS data set options

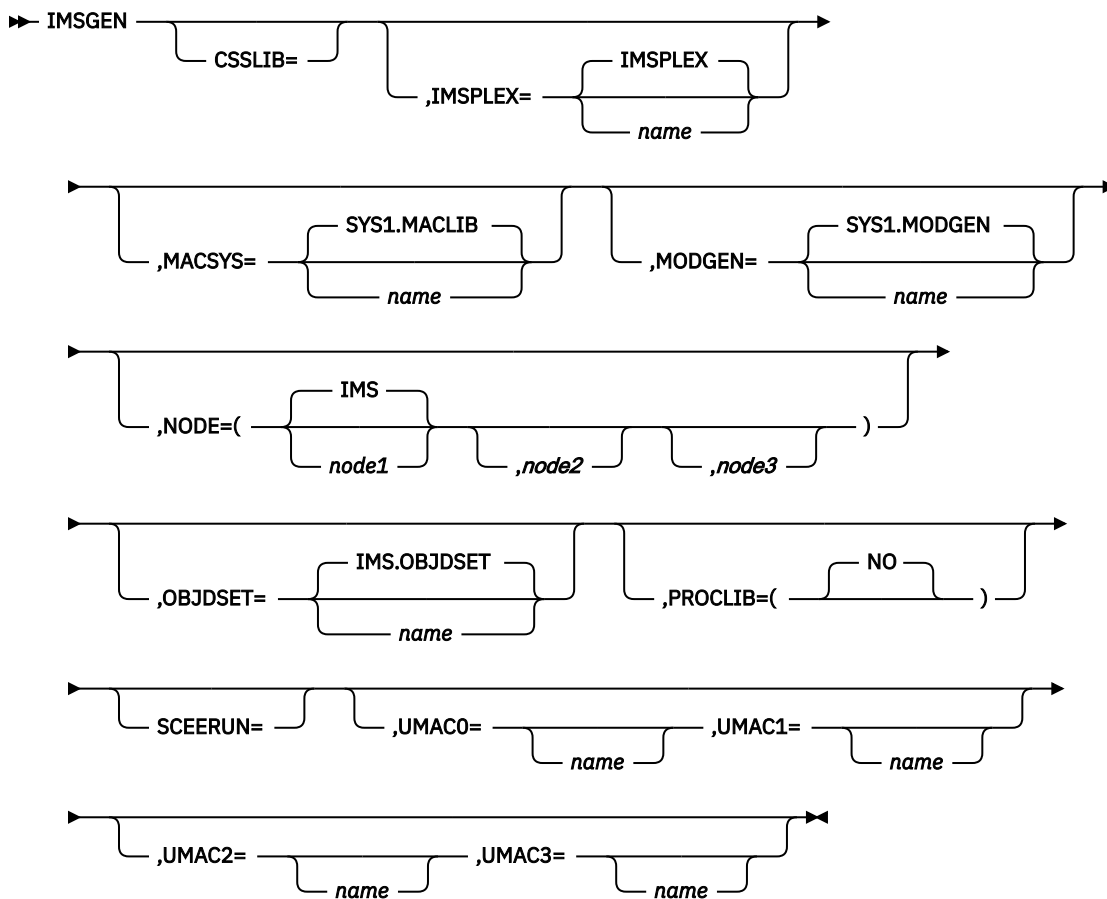

Job Control Language options

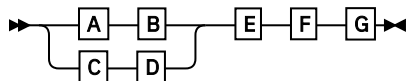

A

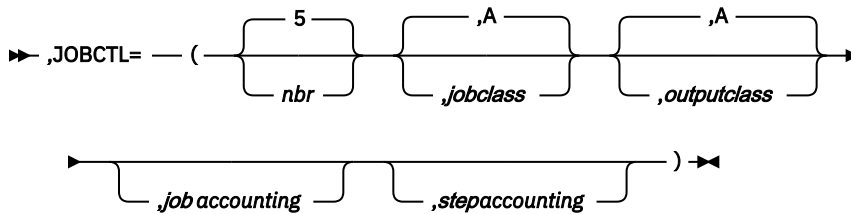

B

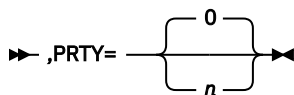

C

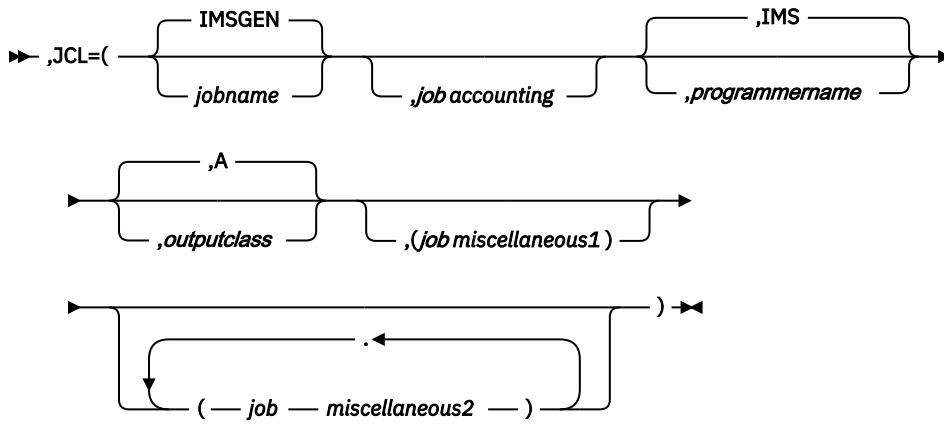

D

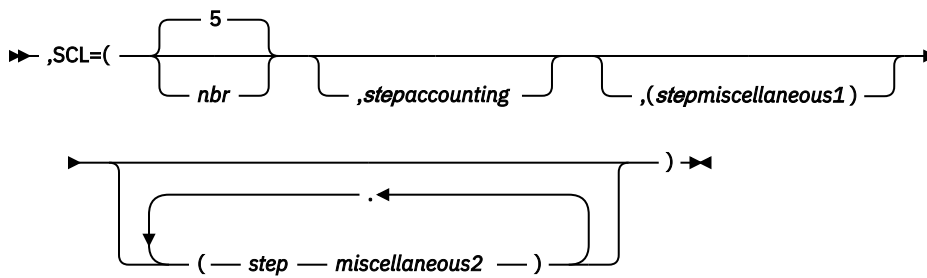

E

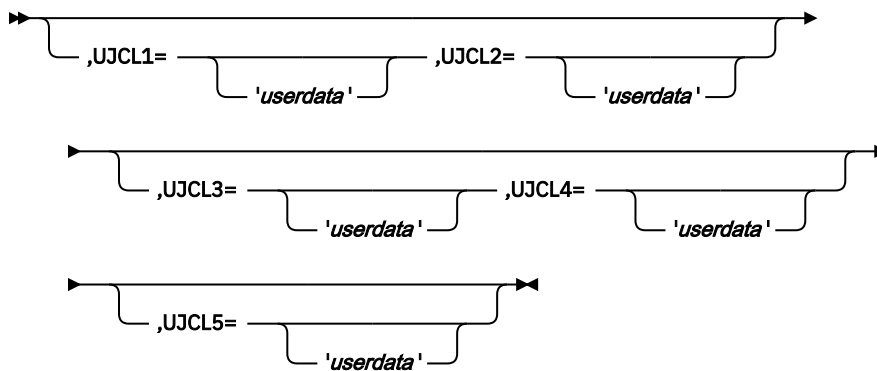

F

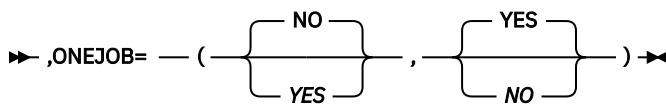

G

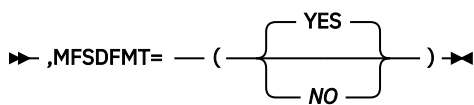

General communication options

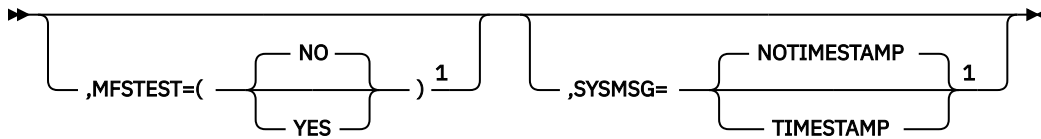

Notes:

¹ If you specify the COMM macro, the general communication option parameters are overridden.

Security options

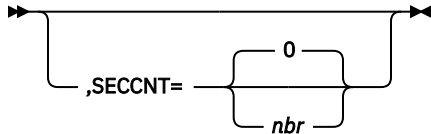

Notes:

Positional parameters

The IMSGEN macro does not include positional parameters.

Keyword parameters

To find which parameters apply to your IMS configuration, refer to [“Selecting the appropriate macros to define your system” on page 5.](#)

The keyword parameters for the IMSGEN macro are divided by the possible options:

- Assembler and binder
- IMS data set
- JCL
- General communication
- Security

Assembler and binder options

ASM=

The first parameter specifies the assembler JCL to be produced for the stage 2 assembly steps. High Level Assembler, the high-level assembler, is the only valid first parameter.

The second parameter can be used to specify the ddname to be used for the assembler object output. If the ddname is not specified, the ddname is SYSLIN.

Avoid the use of DD names other than SYSLIN, SYSGO, and SYSPUNCH if you are using the z/OS System Modification Program (SMP) to apply maintenance to your IMS libraries. SMP does not recognize other DD names during JCLIN processing.

The option of changing the object output ddname is intended to accommodate those users who have installed an assembler and altered its ddname defaults. The stage two assembler execution statement options are `PARM='OBJECT,NODECK,NODBCS'`. The object file output ddname is the one that must be coded in place of the default value of SYSLIN. Also, you must use the default assembler option `ALIGN` for assemblies of IMS modules.

Recommendation: Use `NOUSING` and `FLAG(NOPUSH)` options to avoid assembler errors. Because the assembler code that is created might contain lowercase characters, you should not specify the assembler option `COMPAT(CASE)`.

ASMPRT=

Specifies the assembler print options for those assembler job steps produced by IMS system definition.

ON specifies that assembly listings are to be generated.

OFF specifies that assembly listings for inline assemblies are not to be generated. The default is OFF.

LKPRT=

Specifies binder print options for those binder job steps produced by IMS system definition. These print options include:

Value
Print Option

MAP
Module map

XREF
Cross-reference table (XREF includes the MAP option)

LIST
List of control statements in statement image format

If this parameter is omitted, only binder error messages, if any, are printed.

LKRGN=

Specifies a region size value to be placed on the generated EXEC statements for execution of the binder. This parameter can be specified in kilobytes or megabytes.

In kilobytes, the value can be 1 through 7 decimal numbers (1 through 2096128).

In megabytes, the value can be 1 through 4 decimal numbers (1 through 2047).

LKSIZE=

Specifies the values to be placed in the SIZE parameter of the EXEC statements for the binder job steps.

value1

Specifies the maximum number of bytes of main storage and available virtual storage. This value can be specified in the form *n* (where *n* represents the actual number of bytes of virtual storage, not to exceed 16384000) or *nK* (where *n* represents the number of 1 KB blocks of virtual storage, not to exceed 16000 KB).

value2

Specifies the number of bytes of storage to be allocated for the load module buffer. It is expressed in the form *n* (where *n* cannot exceed 65520) or *nK* (which cannot exceed 63 KB).

Default values are not supplied in LKSIZE for the binder SIZE parameter. If *value1* and *value2* are omitted, the Binder SIZE defaults are used.

Related reading: For a more detailed description of the SIZE option, see *DFSMS/MVS Program Management*.

SUFFIX=

Specifies the alphanumeric suffix character appended to the generated composite control block, nucleus, MFS device characteristics table, and security directory module names when they are put into the IMS.SDFSRESL or IMS.MODBLKS data sets. The IMS online nucleus name always starts with DFSVNUC. The suffix character supplies the eighth character of the nucleus names. If the suffix character equals 0, the online nucleus name is DFSVNUC0. This concept allows the system user to generate multiple IMS systems for use in one environment where the characteristics of each system vary. The default is 0.

The modules that receive the suffix are shown in the following table. If no IMSGEN macro is coded with the default SUFFIX of 0, subsequent functions might fail due to the lack of the default, DFSUDT0.

Table 53. Modules that receive the suffix character

Module 1	Module 2	Module 3
DBFSCD0x, DBFSCD1x	DFSCLVxx	DFSRCTEx
DFSBLK0x	DFSDDIRx	DFSRSR0x
DFSCLCxx	DFSFEDBx	DFSSCD0x, DFSSCD1x
DFSCLIDx	DFSFRB0x, DFSFRB1x	DFSSMB0x
DFSCLL0x	DFSISDBx	DFSSYS0x
DFSCLL1x	DFSISDCx	DFSUDT0x
DFSCLRxx	DFSOPLOx	DFSVNUCx
DFSCLSxx	DFSPDIRx	

The suffix is also appended to the intermediate control block assemblies for SMP/E purposes.

TERM=

Specifies the assembler TERM/NOTERM option for stage 2 assembler job steps produced by the IMS system definition.

YES specifies that the TERM option is in the PARM= field for each of the stage 2 assembler job steps. YES also specifies that the /SYSTEM DD statement is to be built in each of the stage 2 assembler job steps.

NO specifies that the NOTERM option is included in the PARM= for each of the stage 2 assembler job steps. The default is NO.

UPDTPRT=

Specifies whether the IEBUPDTE SYSPRINT is to be produced by IMS system definition stage 2.

ON specifies that the IEBUPDTE SYSPRINT is to be generated. The default is ON.

OFF specifies that the IEBUPDTE SYSPRINT is to be suppressed. This includes the suppression of any errors or warnings issued by the IEBUPDTE utility.

IMS data set options

CSSLIB=

Specifies the name of the z/OS (R2V10 or above) callable services library data set that is part of the concatenation of the STEPLIB DD statement of the DFSJMP and DFSJBP procedures. The specified data set name cannot be longer than 44 alphanumeric characters. If the keyword is not specified, a default value of SYS1.CSSLIB is used as the data set name.

No system definition is needed unless you are using the DFSJMP or DFSJBP procedure library members created by system definition.

IMSPLEX=

Specifies the data set qualifier (or qualifiers) for the OLCSTAT data set. This name should be the same for all IMS systems running in the same IMSplex because they all share the same OLCSTAT data set.

The name specified on the IMSPLEX option can be from one to 35 characters in length (including embedded periods). The first character of each level of qualification must be a letter, @, \$, #, or a number (zero through 9). The IMSPLEX name must conform to z/OS data set naming conventions. The default name is IMSPLEX.

MACLIB=

This keyword is obsolete.

MACSYS=

Specifies the name for the MACLIB data set to be used in the stage 2 assemblies. The specified data set name cannot be longer than 44 alphanumeric characters.

MODGEN=

Specifies the name for the MODGEN data set to be used in the stage 2 assemblies. The specified data set name cannot be longer than 44 alphanumeric characters.

NODE=

Specifies the node assigned to IMS data set names.

node1

Specifies the node to be assigned to all IMS data set names, as related to the use and definition of the data set names, by IMS system definition. The specified node can contain from 1 to 26 characters, including embedded periods. The first character of each level of qualification must be a letter, @, \$, or #. The remaining seven characters can be any of the preceding characters and the numerals zero through nine. The node name must conform to z/OS data set naming conventions. The default node generated is IMS.

node2

Specifies the node to be assigned to the IMS data set names listed in Table 54 on page 444. This node overrides the *node1* assignment for these specific data sets. The character set restrictions are as defined for *node1*.

node3

Specifies the node to be assigned to the IMS data set names listed in Table 54 on page 444. This node overrides the *node1* assignments for these specific data sets. The character set restrictions are as defined for *node1*.

Table 54. Node assignments for IMS data set names			
node1		node2	node3
• MSDBCP1	• IMSLOG2	• PROCLIB	• ADFSMAC
• MSDBCP2	• RDS	• SDFSRESL	• ADFSLOAD
• MSDSCP3	• RDS2	• SDFS MAC	• ADFSSRC
• MSDBCP4	• PGMLIB	• JOBS	• LGENIN
• MSDBDUMP	• PSBLIB	• MODBLKS	• LGENOUT
• MSDBINIT	• DBDLIB	• MODBLKSA	
• QBLKS	• ACBLIB	• MODBLKSB	
• QBLKSL	• ACBLIBA		
• SHMSG	• ACBLIBB		
• SHMSG L	• REFERAL		
• LGMSG	• FORMAT		
• LGMSG L	• FORMATA		
• MODSTAT	• FORMATB		
• MODSTAT2	• TFORMAT		
• IMSMON	• SYSONnn		
• IMSLOG			

OBJDSET=

Specifies the name of a cataloged partitioned data set into which assembler object modules are assembled during stage 2 of IMS system definition. The specified data set name must not be longer than 44 alphanumeric characters. If this parameter is not supplied, these modules are placed in IMS.OBJDSET.

PROCLIB=

In IMS 15.4, this parameter is no longer used. Sample procedures are generated in IMS.SDFSPROC data set. Only **PROCLIB=NO** is allowed.

NO

Does not generate system procedures.

SCEERUN=

Specifies the name of the System C Runtime Library data set that is part of the concatenation of the STEPLIB DD statement of the DFSJMP and DFSJBP procedures. The specified data set name cannot be longer than 44 alphanumeric characters. If the keyword is not specified, a default value of CEE.SCEERUN is used as the data set name.

USERLIB=

In IMS 15.4, this parameter is obsolete. The following description is for your reference only.

Specifies the name of the library in which user-written routines, such as message edit routines, are to be included in the generated IMS nucleus. If this operand is omitted, the library containing the routines is assumed to be node(2).SDFSRESL data set. The name of the data set, which must be cataloged, must not be longer than 44 characters.

UMACO=

Specifies the name of a data set to be put at the top of the SYSLIB concatenation of the stage 2 assembly job steps. The specified data set name cannot be longer than 44 alphanumeric characters.

UMAC1=, UMAC2=, and UMAC3=

Specifies the name of a data set to be concatenated to the SYSLIB DD statement of the stage 2 assembly job steps. The specified data set name cannot be longer than 44 alphanumeric characters.

Typically MACSYS is used for either SYS1.MACLIB or SYS1.AMACLIB, and MODGEN is used for either SYS1.MODGEN or SYS1.AMODGEN. If the SYS1.AMACLIB and SYS1.AMODGEN data sets are specified, the UMAC1= keyword must specify SYS1.ATSOMAC. This ensures that all macros that might be referenced are at the same level.

If no value is provided, the corresponding statement is dropped from the SYSLIB DD.

JCL options

Use the first two parameters (JOBCTL and PRTY) or the last two (JCL and SCL).

JOBCTL=

The following parameters are valid:

nbr

Specifies the number of steps per JOB statement to be produced by system definition stage 1 for execution of stage 2. The maximum allowable value is 255; the default is 5. Regardless of the value specified, a JOB statement is produced for the beginning of the bind steps and for the nucleus bind step (if applicable).

jobclass

Specifies the job class to be generated on the stage 2 JOB statement. The default is A.

outputclass

Specifies the output class to be generated for the stage 2 JCL. The default is A.

job accounting, step accounting, or both

Specifies that job accounting data, step accounting data, or both, be placed in the stage 2 JCL. The length of each set of (job and step) accounting data cannot exceed 50 bytes. If job accounting data is specified, a programmer name of IMS is provided.

When the accounting information fields contain special characters (except hyphens), special considerations apply to the manner in which this field is specified. See the examples for the JCL.

PRTY=

Specifies the priority placed on the JOB statements for IMS system definition stage 2 jobs. The default is priority 0.

JCL=

The following parameters are valid:

jobname

Specifies a maximum of six alphanumeric characters to be used as the first portion of the generated job names. The last two characters of the job names are internally generated, sequentially incremented, hexadecimal numeric values representing the relative position of each job in the stage 2 stream. The default is IMSGEN.

The character set that can be used is described on the node keyword.

job accounting

Specifies job accounting data to be placed in the stage 2 JCL. The length of the accounting data cannot exceed 50 bytes.

When the accounting information fields contain special characters (except hyphens), special considerations apply to the manner in which this field is specified. See the examples for the JCL.

programmername

Specifies the programmer name to be placed in the stage 2 JCL. The default is IMS.

outputclass

Specifies the output class to be generated for the stage 2 JCL. The default is A.

job miscellaneous 1 & 2

Specifies any additional parameters the user can desire to have placed in the stage 2 JOB statements. Length of this parameter cannot exceed 60 bytes. If you code this parameter, do not code the MSGCLASS parameter.

MFSDFMT=

Specifies whether (YES) or not (NO) the default message format screens are built in stage 2 of IMS system definition. If MFSDFMT=NO, stage 2 does not have the default MFS screens generated in stage 2. The default is YES.

ONEJOB=

Subparameter 1 specifies whether (YES) or not (NO) a single job is to be built for stage 2. The default is NO. If ONEJOB=NO, stage 2 has a multiple of job steps as specified in JOBCTL= subparameter 1.

Subparameter 2 specifies whether (YES) or not (NO) condition code checking for the bind steps is to be performed. If ONEJOB=(YES,YES) is specified, condition code checking is done in the bind steps. These steps are bypassed if any previous step did not complete with a condition code of 0. The default for subparameter 2 is YES if subparameter 1 is YES.

When ONEJOB= is specified for a single JOB statement, JOBCTL= and SCL= subparameter 1 are ignored.

If condition code checking is being specified for SCL= and ONEJOB= subparameter 2 is YES, a JCL error occurs due to the specification of duplicate COND= parameters.

SCL=

The following parameters are valid:

nbr**step accounting**

Specifies step accounting data to be placed in the stage 2 JCL. The length of the accounting data cannot exceed 50 bytes.

When the accounting information fields contain special characters (except hyphens), special considerations apply to the manner in which this field is specified. See the examples for the JCL.

step miscellaneous

Specifies any additional parameters that you might want to place in the stage 2 EXEC statements. The length of this parameter cannot exceed 50 bytes. Do not code REGION= here, because internal IMS processing automatically generates this parameter. Do not code COND= if the MFSDFMT=NO keyword is not coded. Some of the default MFS job steps have COND= already coded.

UJCL1=,...,UJCL5=

Specifies the contents of a JCL statement that is placed between the JOB statement and the first EXEC statement in the stage 2 job stream. The specified statement cannot be longer than 60 characters. No other syntax checking of the parameter contents is done.

The intent of these keywords is to provide comment or JES control statements in the stage 2 job stream. For example, these parameters can be used to add ROUTE statements, or JOBLIB DDs.

If no value is provided, the corresponding statement is dropped from the SYSLIB DD.

General communication options

All communication operands specified are ignored and a warning message is issued if the COMM macro is specified.

MFSTEST=

Specifies whether (YES) or not (NO) the Message Format Service test facility, MFSTEST, is to be included in the generated system. YES is invalid for systems not containing MFS terminals. The default is NO.

The use of MFSTEST can degrade IMS performance due to MFSTEST use of the communication line buffer pool.

SYMSG=

Specifies whether (TIMESTAMP) or not (NOTIMESTAMP) the system message time-stamp facility is to be included for the generated system. The default is NOTIMESTAMP.

When TIMESTAMP is specified, the time that a message was generated is inserted between the message number and the message text for each message in the table.

Security options

All the security options are ignored or overridden if the COMM macro or the security initialization parameters are specified.

SECCNT=

Specifies the maximum number of terminal and password security violations to be accepted per physical terminal and transaction command violations per transaction before master terminal notification of such violation. The default is 0, which nullifies notification to the master terminal. The number specified can range from 0 through 3.

If SECCNT is not 0, the master terminal is notified for every violation.

IMSGEN macro statement - example 1

The following figure is one example of an IMSGEN macro statement.

IMSGEN	ASMPRT=ON, LKPRT=(MAP, LIST), SUFFIX=9,	72
	OBJDSET=IMSXXX.OBJ,	X
	NODE=IMSXXX	X

The example JCL indicates that:

- An assembly listing is requested.
- Binder print options are MAP and LIST.
- Composite control block, nucleus, map module, nucleus and security directory blocks module suffix is 9.
- The cataloged partitioned data set into which assembler load modules are to be placed is IMSXXX.OBJ.
- The library containing user routines is IMSXXX.USER.
- All IMS data set names are to be prefixed by the node IMSXXX (that is, IMSXXX.SDFSRESL).

IMSGEN macro statement - example 2

The examples of the IMSGEN macro statement shown here compare the JOB and EXEC statements produced using the JOBCTL and PRTY keywords to the statements produced using the JCL and SCL keywords.

```
IMSGEN JOBCTL=(4,D,A,(P01,9987)),PRTY=8                                72
//IMSGEN1 JOB (P01,9987),IMS,MSGLEVEL=1,MSGCLASS=A,
CLASS=D,PRTY=8
IMSGEN JCL=(OSCAR,(P01,9987),FELIX,,(MSGLEVEL=1,                    X
PRTY=3,TYPRUN=HOLD))
//OSCAR01 JOB (P01,9987),FELIX,MSGLEVEL=1,MSGCLASS=A,
PRTY=3,TYPRUN=HOLD
IMSGEN JCL=(GEORG,(P01,"9/12/99"),IMS,D,(PRTY=3)),                X
SCL=(3,("/83468"),(PARM=123))
//GEOG01 JOB (P01,"9/12/99"),
// IMS,
// PRTY=3,
// MSGCLASS=D
//STEP1 EXEC PGM=IEBUPDTE,PARM=NEW,
// ACCT=("/83468"),
// PARM=123
```

When the accounting information consists of more than one subparameter, you must enclose the information in parentheses, not apostrophes. For example:

```
(5438,GROUP6).
```

If any of the subparameters contains special characters (except hyphens), enclose that subparameter in double apostrophes, not quotation marks. For example:

```
(5438,' '12/15/99: ' ').
```

Related reference

[“DFSDSCMx member of the IMS PROCLIB data set” on page 815](#)

When the Extended Terminal Option (ETO) is enabled, IMS generates ETO descriptors during stage 1 system definition and stores them in the DFSDSCMx member of the IMS.PROCLIB data set.

LINE macro

Use the LINE macro to describe both switched and nonswitched communication lines to IMS. The LINE macro provides the address and characteristics of one line in the line group specified by the LINEGRP statement.

The LINE macro statement describes communication lines. If the line described has only one terminal attached, only one TERMINAL macro instruction is included after the LINE macro instruction. Multiple TERMINAL macro instructions are included if the description is for a multidrop line. For nonswitched lines, multiple NAME macro instructions can be included after each TERMINAL macro instruction that follows a LINE macro instruction. Each LINE macro instruction must be followed by at least one TERMINAL macro instruction.

Dynamic definition

Communication lines cannot be dynamically defined.

Supported environments

The LINE macro can be used in the DB/DC and DCCTL environments.

Syntax

All lines

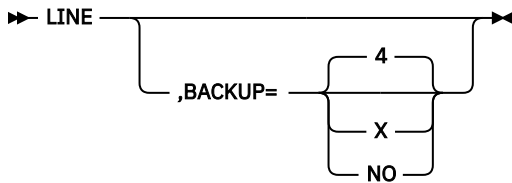

All lines except spool

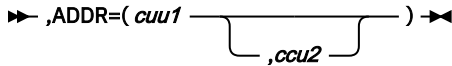

Disk, tape, and spool lines only

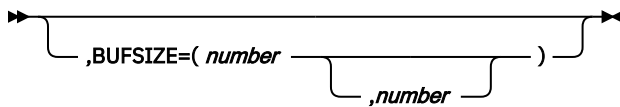

Positional parameters

The LINE macro does not include positional parameters.

Keyword parameters

To find which parameters apply to your IMS configuration, refer to [“Selecting the appropriate macros to define your system” on page 5](#).

ADDR=

Specifies the address of the communication line as defined in the Transmission Control Unit. The address value is three or four hexadecimal digits between 0000 and FFFF. All line addresses specified in the system definition must be unique values. This operand is used only to generate IMS DD statements for cataloged procedures. It is not allowed if the terminal is a 3270 local. This operand is not required for SPOOL line groups.

This operand is ignored for UNITYTYPE=PRINTER when a JES spool data set (SYSOUT=X) is to be used rather than a local printer. When XRF is used, a second optional device address can be specified with the ADDR keyword.

BACKUP=

Specifies (for XRF only) the control of the automatic restart after takeover. Use only when HSB=YES is specified on the IMSCTRL macro.

X is a numeric integer from 1 (lowest) to 7 (highest), inclusive, that specifies the priorities for reestablishing the session. If the entire keyword or the operand is omitted, the default is 4. Specifying BACKUP=NO suppresses the automatic restart of the devices after a takeover.

BUFSIZE=

This operand is only valid for DISK, TAPE, and SPOOL lines.

For DISK, TAPE, or SPOOL lines, this operand is used to specify, in bytes, the maximum output buffer size to be used for the line. The operand is required. The minimum specification is 16; the maximum specification is 32 760.

Use of SYSIN local card reader: When the DD statement for a line (specified in the LINEGRP macro statement as UNITYTYPE=READER) does not allocate a card reader device, the following conditions apply:

- If IMS is running as a batch program, the DD statement referring to the line must contain DCB=BLKSIZE=80.
- If IMS is running as a system task, the SYSIN test stream must be placed in a sequential data set with the DCB attributes RECFM=F and BLKSIZE=80. The SYSIN test stream must be pointed to by a DD statement for a reader line within the IMS procedure.

Although VTAM requests are priority-ordered by IMS, the active requests can be completed in any order because of internal VTAM conflicts and pacing.

LINEGRP macro

The LINEGRP macro defines the beginning of a set of macro instructions that describe your telecommunications system.

The LINEGRP macro statement is the first in a series of macros. The IMS macros that can be part of a LINEGRP macro set are LINE, TERMINAL, and NAME.

Dynamic definition

Your telecommunications system cannot be defined dynamically.

Supported environments

The LINEGRP macro can be used in the DB/DC and DCCTL environments.

Syntax

All line groups

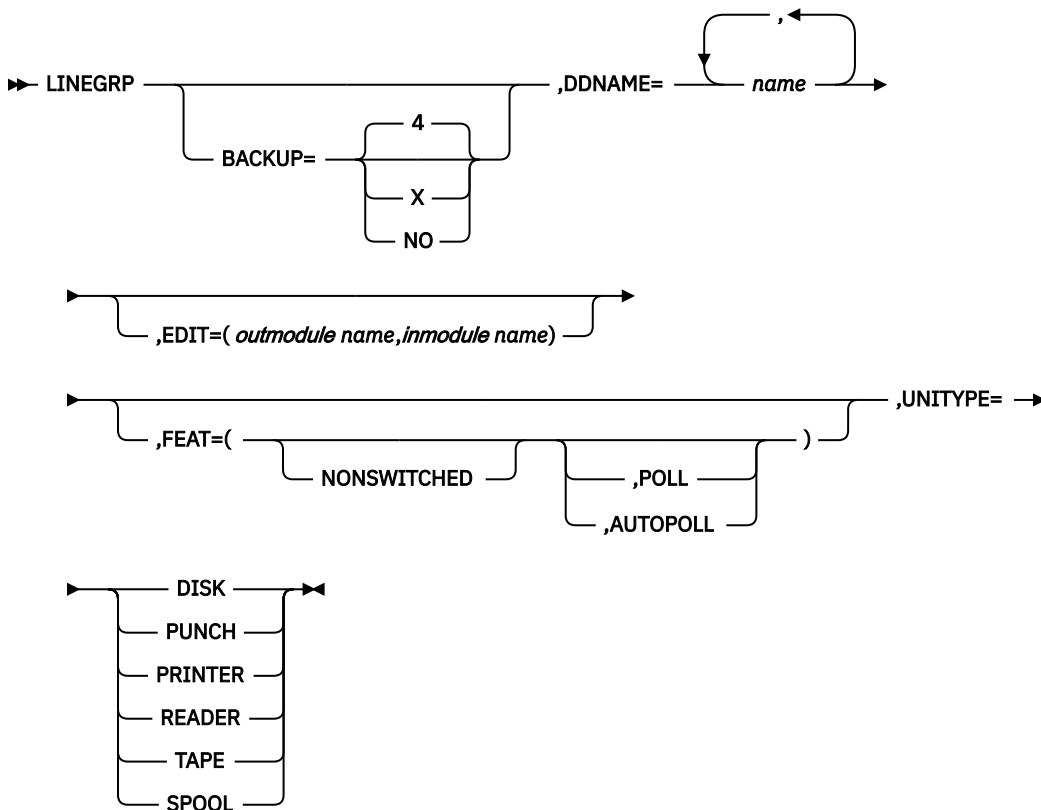

Positional parameters

The LINEGRP macro does not include positional parameters.

Keyword parameters

To find which parameters apply to your IMS configuration, refer to [“Selecting the appropriate macros to define your system” on page 5.](#)

BACKUP=

Specifies (for XRF only) the control of automatic restart after takeover. Use only when HSB=YES is specified on the IMSCTRL macro.

X is a numeric integer from 1 to 7, inclusive, which specifies the priority assigned to reestablishing the session. When either the keyword or the operand is omitted, the default is 4. Specifying BACKUP=NO suppresses the automatic restart of the devices after a takeover.

DDNAME=

Specifies a one- to eight-character name that associates the generated DCB for this line group, within the IMS nucleus control block, with the generated JCL DD statements identifying the lines within the line group. If the line group being defined is a SPOOL line group, a list of up to 20 names can be specified: 255 SPOOL data sets, but no more than 20 names per line group can be specified. Each SPOOL name specification is associated, in the order in which it was specified, with the SPOOL data set names that you specify for the SPOOL print procedures, including DFSWTxxx, IMS, and DCC procedures. These procedures are provided as samples in SDFSPROC and can be modified to include actual specifications.

The names must begin with an alphabetic character, and the operand is required. The following names cannot be used as LINEGRP ddnames:

- DFSRESLB
- DUMP
- IEFORDER
- IEFORDER2
- IMSACB
- IMSDBL
- IMSDILIB
- IMSLOG
- IMSLOGR
- IMSLOGR2
- IMSLOG2
- IMSMON
- IMSRDS
- IMSSPA
- IMSTFMT
- IMSUDUMP
- LGMSG
- MSDBCP1
- MSDBCP2
- MSDBDUMP
- MSDBINIT
- PRINTDD
- PROCLIB

- QBLKS
- SHMSG

Recommendation: Allocate at least two data sets.

EDIT=

Specifies a one- to eight-character, user-supplied physical terminal output edit routine and a one- to eight-character, user-supplied physical terminal input edit routine for the terminal type in this line group.

This routine cannot be the same as the one that is used on a TRANSACT EDIT= parameter.

FEAT=

Specifies that this group of telecommunication lines is leased (NONSWITCHED). This is the default.

Polling features are ignored, and no polling list is generated if any of the following values are specified for UNITYPE= keyword: READER, PRINTER, PUNCH, TAPE, DISK, and SPOOL.

Direct SYSOUT specifications (PRINTER, PUNCH, TAPE, or DISK) do not require that a specific device type is assigned at IMS execution time. All specifications except PRINTER affect only default BUFSIZE or generated JCL. Specifying PRINTER results in execution time being translated to the 48-character set, lowercase is translated to uppercase, and all other codes translated to periods(.). If a specification other than PRINTER is used, no translation occurs. If a line not generated as a PRINTER is allocated to a printer having the universal character set feature (UCS), and fold mode operation is used, unprintable characters print as extraneous alphanumerics.

UNITYPE=

Specifies the terminal device type contained in this line group.

Valid UNITYPE parameters are DISK, PUNCH, PRINTER, READER, TAPE, and SPOOL.

When a JES SPOOL DATASET (SYSOUT) is used, UNITYPE = PRINTER must be specified.

Sample LINEGRP macro JCL

The JCL example below shows the LINEGRP macro and the resulting DDNAME/DSNAME and print procedure associations for a SPOOL line group.

```
LINEGRP DDNAME=(NAME1, NAME2) , UNITYPE=SPOOL
LINEGRP DDNAME=(NAMEA, NAMEB) , UNITYPE=SPOOL
```

You must define the SPOOL print procedures for each line group. Use the sample SPOOL print procedure, IMSWT000, which is provided in SDFSPROC to define your own IMSWTxxx procedures.

The SPOOL print procedure for line group 1 is named IMSWT000. The data set names produced for this print procedure are IMS.SYSO1 and IMS.SYSO2.

The SPOOL print procedure for line group 2 is named IMSWT001. The data set names produced for this print procedure are IMS.SYSO3 and IMS.SYSO4.

The corresponding JCL statements that you define for the IMS online execution procedure are as follows:

```
//NAME1 DD DISP=SHR, DSNAME=IMS.SYSO1
//NAME2 DD DISP=SHR, DSNAME=IMS.SYSO2
//NAMEA DD DISP=SHR, DSNAME=IMS.SYSO3
//NAMEB DD DISP=SHR, DSNAME=IMS.SYSO4
```

If UNITYPE=SPOOL on the LINEGRP macro statement, DD names used in the preceding JCL must agree with the actual DD names specified on this statement.

MSGQUEUE macro

Use the MSGQUEUE macro to define the characteristics of the three message queue data sets: QBLKS, SHMSG, and LGMSG. The information you specify in this macro is also used in a shared-queues environment. The MSGQUEUE macro is required for all DB/DC and DCCTL systems.

You must include the MSGQUEUE macro statement when the type of definition specified in the IMSCTRL macro statement is ALL, ON-LINE, CTLBLKS, or NUCLEUS.

Dynamic definition

The characteristics of the three message queue data sets cannot be dynamically defined.

Supported environments

The MSGQUEUE macro can be used in the DB/DC, DBCTL, and DCCTL environments.

Syntax

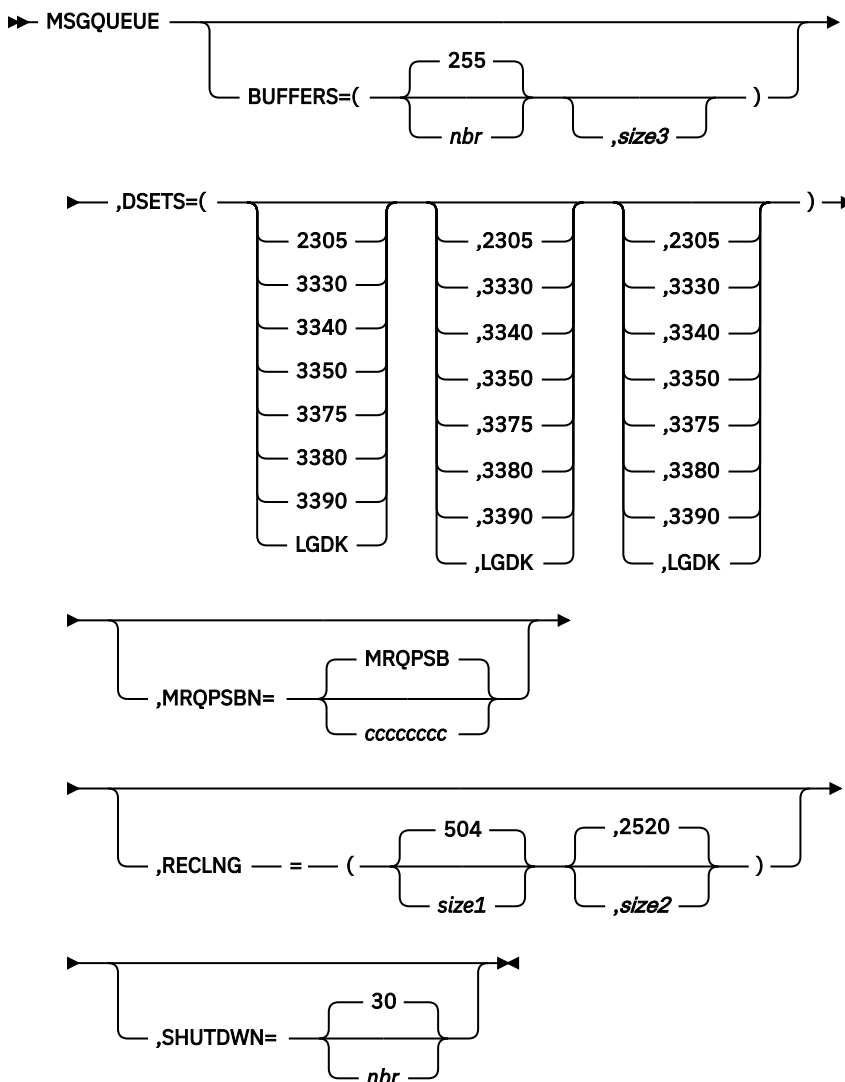

Positional parameters

The MSGQUEUE macro statement does not include positional parameters.

Keyword parameters

To find which parameters apply to your IMS configuration, refer to [“Selecting the appropriate macros to define your system” on page 5](#).

BUFFERS=

Specifies the number of buffers to allocate for message queue management, and the block size to be assigned for all three message queue data sets. If *nbr* is not specified, a default of 255 is used. The minimum *nbr* specification is 3; the maximum is 9999. At execution time, the minimum value for buffers in a shared queues environment is increased to 200. If *size3* is not specified, it is calculated by the following formula:

$$\text{SIZE3} = ((\text{SIZE1} + \text{SIZE2} - 1) / \text{SIZE1}) \times ((\text{SIZE1} + 55) / 56) \times 56$$

For the division operations in this formula, only the integer portion of the result is used; the fractional portion of the result is truncated.

This calculation can leave null space at the end of the buffer block for short and long message records.

size1 and *size2* should be an even multiple of the QBLKS LRECL of 56.

If the RECLNG defaults of *size1* (504) and *size2* (2520) are used, then *size3* of BUFFERS equals 2520. The maximum specification for *size3* is 30632, or the track length of the device on which the data set resides, whichever is smaller. All sizes specified are rounded up to multiples of 4.

RECLNG can be changed before a cold start of IMS, but if a smaller value is specified before a BUILDQ restart, the restart might abend.

You should not allocate less space for a restart of IMS than was allocated for the prior execution. If a smaller logical record length has been allocated, or if less space for the Message Queue data sets has been allocated for restart with BUILDQ, the restart process may terminate abnormally.

DSETS=

Specifies the device types on which the three message queue data sets (IMS.QBLKS, IMS.SHMSG, and IMS.LGMSG, respectively) are to reside. If all three data sets are to reside on the same device type, you can specify just the first parameter.

You can specify the following device types: 2305, 3330, 3340, 3350, 3375, 3380, 3390, or LGDK.

When using a 3350, specify the drive format used—3330 or 3350.

LGDK is a generic definition for disk drives that have a track size equal to or greater than 32767 bytes. The 3375, 3380, 3390, and future devices can also be defined as LGDK.

MRQPSBN=

Specifies the one- to eight-character alphanumeric name of the IBM IMS Queue Control Facility for z/OS (QCF) program specification block. This parameter allows you to override the default MRQ PSB name. If not specified, the default name of MRQPSB is used by the QCF licensed program. The MRQ program can be either defined in system definition with the APPLCTN macro, or, if DRD is enabled, defined dynamically with the CREATE PGM NAME (MRQPSB) SET (BMPTYPE (Y) , SCHEDTYPE (PARALLEL)). The default name is MRQPSB. Regardless of whether you use the default name, you must include a PSB for the message region in the stage 1 system definition. If you do not use the default name, you must specify a name for the MRQPSBN block with the MRQPSBN keyword. If an error is made in specifying the MRQPSBN PSB name, a warning message is issued, and the default name is used.

Note: The MRQPSBN block is for the exclusive use of MRQ and QCF programs. It cannot be used by other user application programs running as MPPs, BMPs, or IFPs. If an attempt is made to use the PSB block by some other user application program, IMS returns a status code of MR and an AIBRETRN code of 00000F0 on the call.

RECLNG=

Specifies the logical record lengths for the short and long message queue data sets, respectively.

The minimum value for *size1* is 392. This size includes user data length of 64 bytes plus minimum prefix size of 328. The value specified for *size1* must be large enough to accommodate the ISC/LU6.1 (type 84) prefix and the Conversation Extension (type 8D) prefix. If shared queues are used, it must also include an additional X'28' bytes. If *size1* is not specified, a default of 504 is assigned.

The minimum value for *size2* is 1176. If *size2* is not specified, a default of 2520 is assigned. The value specified for *size2*:

- Must be equal to or greater than *size1*.
- Cannot exceed the track length of the device on which the data set resides.
- Must be divisible by 4. If it is not, IMS uses the next greater value that is divisible by four as the value of *size2*.
- Should be even multiples of the QBLKS LRECL of 56.
- Should not exceed the size of the OLDS data set block minus the sum of the block descriptor word length (4 bytes) and prefix item.

If a message does not fit in a large queue record (*size2*), IMS either spans it to other queue records, or rejects the message with an error.

Choose values for *size1* and *size2* based on the sizes of the messages processed by the queue manager. When determining which size message queue record to use, the queue manager calculates the size of the message prefix, subtracts that value from the size of the short message queue buffer, and then doubles the remaining value. The queue manager then compares that value to the average user data length for the destination. If the remainder buffer size is greater than or equal to the average user data size, then the short message queue buffer is used. If the remainder buffer size is less than the average user data size, then the large message queue buffer is used. The length of the message prefix varies based on the IMS system options specified.

SHUTDOWN=

Specifies the number of records to be reserved in each data set to allow the system to automatically shut down if the data set becomes filled with unprocessed messages. The maximum valid specification is 32767. The default is 30. In an XRF system, this parameter also reserves the number of records in each of the local message queue data sets (IMS.LGMSGL, IMS.SHMSGL, or IMS.QBLKSL) for shutdown.

The number of records specified should provide enough space in each data set to allow for an orderly shutdown, which depends on message throughput and the number of regions that are scheduled. In general, the following calculation applies:

Maximum number of output messages between synchronization points per application \times number of regions scheduled + 1 input message per logical terminal active at the same time.

Usage information

Some messages (such as MFS) from an input terminal can span message queue records. If messages span message queue records, the size of the input segment has no limit. When messages do not span message queue records, the maximum allowable size for input segments is *size2* minus the amount for various prefix items included with the data portion of the message queue record.

The maximum size allowed for output segments is *size2* minus the amount for various prefix items included with the data portion of the LRECL (message queue record).

Attention: When an output message segment that spans queue records is formatted by MFS, the message might be truncated or formatted incorrectly. To avoid such problems, increase *size2* to prevent spanning.

Prefix items and sizes for the versions of IMS currently in support are displayed in [Table 55 on page 456](#), along with usage comments.

Table 55. Message prefix size

Prefix section	IMS Version 10 and later - size (in bytes)	Comments
Basic ¹	64	All messages
System Segment (81)	56	All messages
	64	All messages with MFS
ISC/LU6.1 Prefix (84) ³	22	All ISC/LU6.1 messages
Extended Prefix (86) ⁴	16	All messages
APPC (LU6.2) (87)	128-512	All APPC messages
OTMA (87)	128-4096	All OTMA messages
Security Prefix (88) ²	22	All messages if RACF or ETO is defined
Workload Manager (89)	24	All messages
System Extension (8A)	24	All messages
MSC Extension (8B)	120	All messages if MSC is defined
TMR (8C)	144	All messages
	144	All messages with shared queues
Conversation Ext. (8D) ^{3,4}	40	All conversational messages
TM/MSC User Prefix (8E) ⁶	5-512	Dependent on using DFSMSCEO User Prefix exit routine
IMS Internal Prefix (8F) ⁷	5-512	Reserved for IMS
User Data Segments ⁵	V	All messages

Note:

1. All messages begin with a basic prefix segment that has no prefix code. If the message is a first or only queue buffer message, it has a basic prefix and some or all the prefixes type 81 through 8D. User data segments can follow the IMS prefixes.

Prefix segments 81 through 8D begin with a 3-byte LLC field where LL is the 2-byte length of the prefix segment (including the LL field) and C is the 1-byte prefix code.

2. The security prefix is included in only the first message buffer if RACF or ETO is used.

3. Because they are not system definition values, the ISC/LU6.1 (type 84) prefix and the conversation extension (type 8D) prefix are always included in the maximum length of the IMS prefix calculated at IMS initialization. If shared queues are used, an additional 40 bytes is added.

4. All segments following the extended prefix header (type 86) are extended prefix segments. The IMS release level determines the size of the extended prefix segments created for a message. When MSC or shared queues are used, a message can be processed by an IMS that is of a different release level than the originating IMS. If the extended prefix segments lengths are greater for the target IMS, IMS can create or increase the size of the extended prefix segments. Extended prefix segments are never shortened.

Recommendation: In an environment where MSC and shared queues are used and IMS systems are of different release levels, use the highest calculated values for *size1* and *size2* for each IMS.

5. User data segments follow the IMS prefix segments.

6. You can request that a user prefix be inserted into the message prefix by using the MSC Routing exit routine (DFSMSCEO). The size of the user prefix can be from 5 bytes to 512 bytes long.
7. The Workload Router Tool (product number 5697-B87) or another IMS tool can request that an internal prefix be inserted into the message prefix. The size of this user prefix can be between 5 bytes to 512 bytes long.

For messages that span message queue records, the first item (basic) is included in each record of the message. Also, if RACF is generated, the RACF item plus a small (4-byte) system segment is included. All other prefix items, if applicable, appear only in the first record of the message.

The values for *size1* and *size2* should be tuned for your system.

Related reading: For information about how to tune the values of *size1* and *size2* after IMS is operational, refer to “Message queue data set allocation in DB/DC and DCCTL environments” on page 153, and to “Initial Optimizing of IMS Buffer Pools” in *IMS Version 15.4 System Administration*.

The result of this tuning should yield a value for *size1* such that the I/O activity is equally split between the IMS.SHMSG data set, containing input and output message segments up to the length of *size1*, and the IMS.LGMSG data set, containing all input and output message segments larger than *size1*.

RECLNG can be changed before a cold start of IMS, but if a smaller value is specified before a BUILDQ restart, the restart may abnormally terminate.

If emergency restart procedures using BUILDQ are to be used, reallocation of logical record and data set spaces must be done carefully. The BUILDQ procedure always restores the message queue entries to the relative position in the respective queue data sets they had at the time they were saved. If the logical record or data set size has been decreased, it may be impossible to perform the restart.

Sample MSGQUEUE macro JCL

The following figure shows an example of the MSGQUEUE macro statement with all data sets on a 3380:

```
MSGQUEUE DSETS=(LGDK),BUFFERS=(40,2520),SHUTDOWN=200
```

This example indicates that the default sizes for the short and long message queue data sets are used. The size of each buffer block is 2520, allowing 1 long message record, 5 short message records or 45 queue block records to fit into a block.

For non-shared queues, 40 buffers are allocated and 200 records in each data set are reserved to allow the system to automatically shut down. For shared queues, the minimum buffer value of 200 is used, and the SHUTDOWN value is ignored.

MSLINK macro

Use the MSLINK macro statement to define a Multiple Systems Coupling (MSC) logical link to another system. The MSLINK macro can be followed by one or more macro statements that define the logical link paths if any are to be defined for this logical link.

Logical links are assigned to physical links during system definition (using the MSPLINK keyword) or dynamically with /MSASSIGN or UPDATE MSLINK commands.

You can define a maximum of 1018 logical links (MSLINK macros) in an IMS system.

Dynamic definition

Logical links can be defined dynamically with the CREATE MSLINK command, instead of defining them statically with the system definition MSLINK macro.

Supported environments

The MSLINK macro can be used in the DB/DC and DCCTL environments.

Syntax

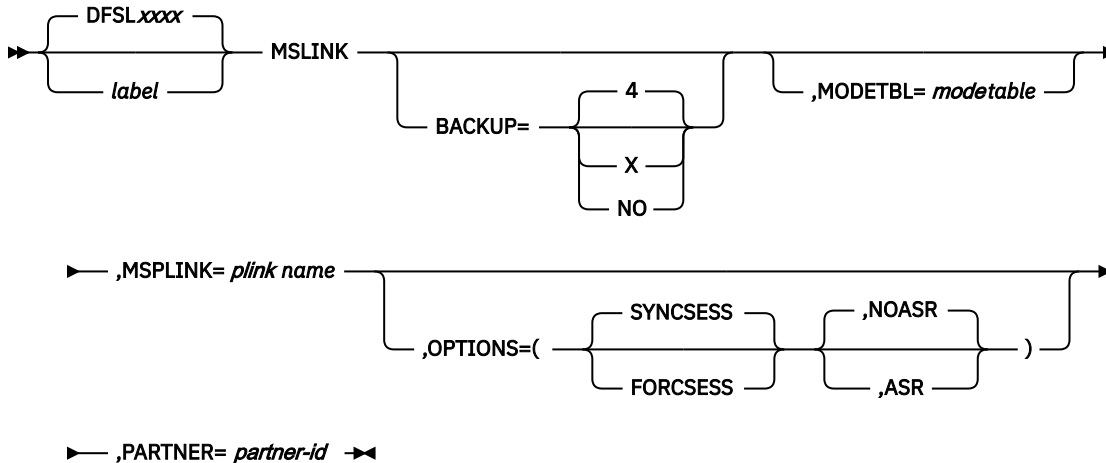

Label field

The label field specifies a 1- to 8-character link name that is used by the type-1 UPDATE and type-2 QUERY and UPDATE commands to identify the logical link. If you do not specify a name, a default name is assigned, DFSLxxxx, where xxxx is the logical link number that system generation assigns to the link. That name is used in the QUERY and UPDATE commands. The logical link name can be changed with the UPDATE MSLINK command.

Positional parameters

The MSLINK macro does not include positional parameters.

Keyword parameters

To find which parameters apply to your IMS configuration, refer to [“Selecting the appropriate macros to define your system”](#) on page 5.

BACKUP=

For XRF-capable IMS systems, controls the automatic restart of TCP/IP and VTAM links after an XRF takeover.

When specified on the MSLINK macro, BACKUP overrides switching options specified on the definition of the associated physical link. Use only if HSB=YES is specified on the IMSCTRL macro.

X is a numeric integer from 1 to 7, inclusive. It sets priorities for reestablishing the session. When either the BACKUP keyword is omitted or no value is specified for BACKUP on either the MSPLINK macro or the MSLINK macro, the default is 4. NO suppresses the session recovery of the MSC physical link at takeover.

Although BACKUP prioritizes the order in which IMS restarts TCP/IP and VTAM links, the active requests might be completed in any order because of variables such as internal VTAM conflicts and pacing, TCP/IP network traffic, and so on.

MODETBL=

Specifies the name of the VTAM logon mode table entry (logon mode name) containing the SNA bind parameters to be used when a session is established for this terminal. The maximum is 255 unique names for each IMS system.

This function allows a system definition specification for referencing an entry other than the default entry in the user's VTAM logon mode table.

With this function, if MODETBL= is not specified at system definition, no functional or operational change affects the user.

If MODETBL= is specified at system definition, the specified entry name is used.

You can display the current MODETBL name using either the /DISPLAY command or the QUERY MSLINK command. You can override the MODETBL name by using any of the following commands:

- The VARY ACT, LOGON= command by the network terminal operator
- The /RST or the /CHANGE command by the master terminal operator
- The type-2 command UPDATE MSLINK NAME(*linkname*) SET(MODETBL(*modetablename*)) through the OM API

If the VTAM-node=name being defined is in another domain (that is, a cross-domain resource), the MODETBL parameter need not be specified.

Related reading: See *z/OS Communications Server: SNA Programming* for additional information.

MSPLINK=

This operand identifies the physical link to which this logical link is assigned. If you do not specify this operand, no assignment to a physical link is made during system definition. You can assign this logical link to a physical link later by using either the /MSASSIGN command or the type-2 command **UPDATE MSLINK** NAME(*linkname*) SET(MSPLINK(*msplinkname*)). You must assign the logical link to a physical link before communication can be established between the two systems.

When specified, the MSPLINK macro must be defined before the MSLINK macro.

OPTIONS=

This parameter allows you to specify certain options for session initiation and restart. The specifications made on this OPTIONS parameter must be consistent with the MSLINK OPTIONS specification in the partner systems.

The OPTIONS parameter is valid for MSC TCP/IP and MSC VTAM links only.

You can specify the following values on the OPTIONS= keyword:

SYNCSSESS|FORCSSESS

SYNCSSESS indicates that session initiation is to be completed only if session resynchronization is successful. Successful session resynchronization occurs when the message sequence numbers of the two logical units in session agree, or when the sequence number of the sender is not less than the sequence number of the receiver. The default is SYNCSSESS.

FORCSSESS forces the session to be completed regardless of whether session resynchronization is successful.

During IMS execution, this option can be overridden by either the type-1 command /**CHANGE LINK** *nn* FORCSSESS|SYNCSSESS|COLDSESS or the type-2 command **UPDATE MSLINK** NAME(*linkname*) SET(SYNCOPT(FORCSSESS|SYNCSSESS|COLDSESS)).

ASR|NOASR

When using the Session Outage Notification facility, specifies whether automatic session restart (ASR) processing is enabled for a defined node. NOASR is the default.

The ASR|NOASR option does not apply to MSC TCP/IP links.

ASR works only if both sides of the link are using the ASR option.

Specifying ASR or NOASR on the MSLINK macro overrides ASR specifications on the TYPE and MSPLINK macros.

To display the current ASR option you can use either of the following commands:

- The type-1 command /**DISPLAY**
- The type-2 command **QUERY MSLINK** NAME(*linkname*) SHOW(STATUS)

To change the current ASR option you can use either

- The type-1 command /**CHANGE**
- The type-2 command **UPDATE MSLINK** NAME(*linkname*) SET(ASR(OFF|ON))

PARTNER=

The value for *partner-id* is a two-character alphanumeric identification. It ensures that the two related logical links in two systems are always logically and physically connected. Both systems must have MSLINK macro statements with the same value for *partner-id*. A logical link can be assigned to a different physical link; the two systems still communicate through the logical link, which remains as defined.

You can modify the partner ID by using the type-2 command `UPDATE MSLINK NAME(linkname) SET(PARTNER(partner-id))`.

MSNAME macro

The MSNAME macro provides a name for the remote and local system identifications that it represents. The MSNAME macro can be followed by one or more NAME macros that define remote logical terminals. MSNAMEs are also referred to as logical link paths.

Dynamic definition

Logical link path names for remote and local MSC systems can be defined dynamically with the CREATE MSNAME command, instead of defining them statically with the system definition MSNAME macro.

Supported environments

The MSNAME macro can be used in the DB/DC and DCCTL environments.

Syntax

➤ *label* — MSNAME — SYSID=(*remote system identification* ,*local system identification*) ➤

Label field

The label field *msname* is a one- to eight-character alphanumeric name used externally in commands. Link names, *msname*, transaction codes, and logical terminal names, collectively, cannot contain duplicates. Specifying the *msname* label field is required.

Positional parameters

The MSNAME macro does not include positional parameters.

Keyword parameters

To find which parameters apply to your IMS configuration, refer to [“Selecting the appropriate macros to define your system”](#) on page 5.

SYSID=

remote system identification identifies the remote system that is represented by this name.

remote system identification specification must not have been previously defined as:

- A remote system identification within a previous MSNAME macro statement.
- A local system identification within an APPLCTN, TRANSACT, or MSNAME macro statement.

The *local system identification* specifies the system identification that is to be used for routing messages back to this system.

local system identification specification must not have been previously defined as a *remote system identification* within a previous MSNAME macro statement.

Values from 1 through 2036 are valid.

You can change the local or remote system IDs of the SYSID= keyword by using the type-2 command UPDATE MSNAME NAME(*msname*) SET(SIDR(*remote_SID*), SIDL(*local_SID*)).

A one-to-one relationship exists between remote SYSIDs and MSNAMEs. APPLCTN and TRANSACT macro statements must refer to remote SYSIDs specified in MSNAME statements in the same system definition when defining remote applications.

MSPLINK macro

The MSPLINK macro defines an MSC physical link.

You can define an MSC physical link to use any one of the following types of connection between two systems:

- Channel-to-channel connection (CTC)
- Main-storage to main-storage connection (MTM)
- Transmission Control Protocol/Internet Protocol (TCP/IP)
- Virtual Telecommunications Access Method (VTAM)

You can define a maximum of 1018 physical links (MSPLINK macros) in an IMS system.

Dynamic definition

Physical links can be defined dynamically with the CREATE MSPLINK command, instead of defining them statically with the system definition MSPLINK macro.

Supported environments

The MSPLINK macro can be used in the DB/DC and DCCTL environments.

Syntax

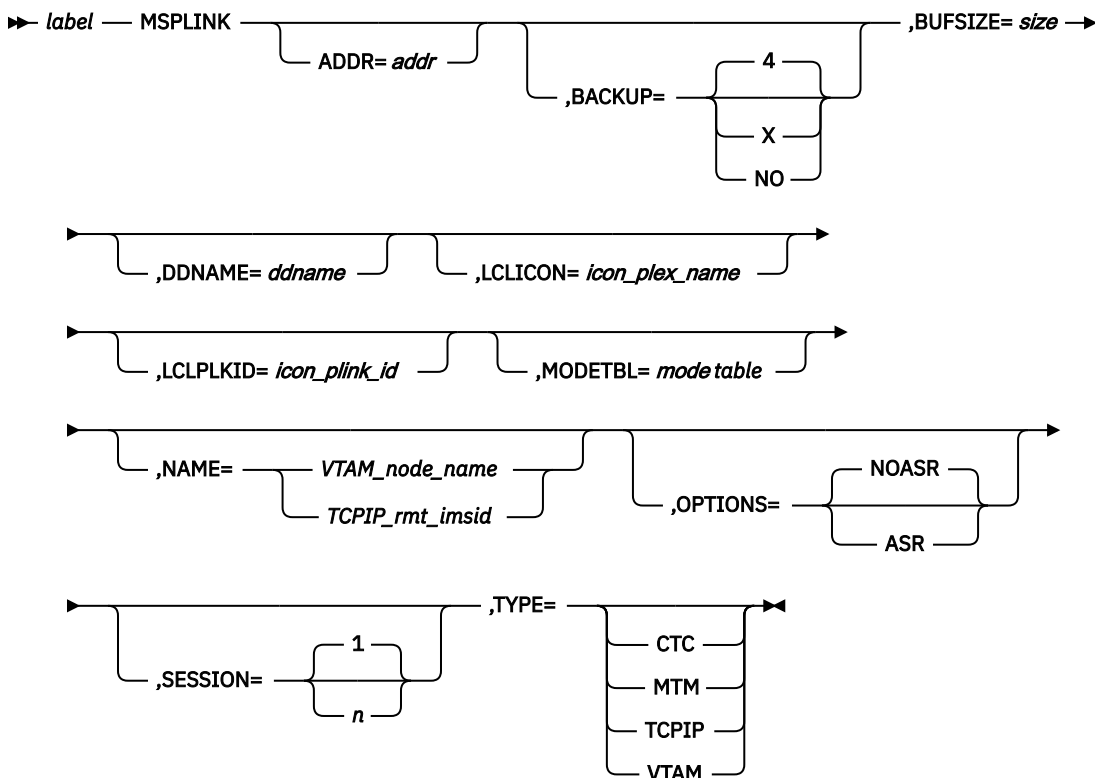

Label field

The MSPLINK name specifies a 1- to 8-character alphanumeric name for this physical link. You must specify this name. This name is used (in the MSPLINK= keyword operand of the MSLINK macro) to assign a logical link to this physical link. You can change this name using the UPDATE MSPLINK command.

Positional parameters

The MSPLINK macro does not include positional parameters.

MSPLINK macro keyword parameters

To find which parameters apply to your IMS configuration, see [“Selecting the appropriate macros to define your system” on page 5](#).

ADDR=

Specifies the address of the communication line or the address of the channel-to-channel adapter. The address value can be three or four hexadecimal digits. This operand is required for CTC link types and invalid for other link types.

All devices attached to the same channel as the CTC adapter must be accessible through an alternative channel. In addition, do not attach system resources (for example, paging devices) to the same channel as the CTC adapter.

You can change the value specified on the ADDR= keyword by using the type-2 UPDATE MSPLINK SET(ADDR(*addr*)) command.

BACKUP=

For XRF-capable IMS systems, controls the automatic restart of TCP/IP and VTAM links after an XRF takeover.

X is a numeric integer from 1 to 7, inclusive, that specifies the priority for reestablishing the session. The default is 4. Specifying BACKUP=NO suppresses the automatic restart of the MSC physical link.

Although BACKUP prioritizes the order in which IMS restarts TCP/IP and VTAM links, the active requests might be completed in any order because of variables such as internal VTAM conflicts and pacing, Internet Protocol network traffic, and so on.

You can change the value specified on the BACKUP= keyword by using the type-2 UPDATE MSPLINK SET(BACKUP(*backup*)) command.

BUFSIZE=

Specifies the input and output buffer sizes for each logical link assigned to this physical link.

Buffer sizes for all link types can range from 1024 bytes to 65536 bytes.

The same buffer size must be specified by the IMS systems at each end of a physical link.

IMS initializes the MSC link buffers to the size specified on the BUFSIZE parameter.

If you are using bandwidth mode, a BUFSIZE value of 1024 is too small to send multiple messages with one buffer. A value of at least 4096 is recommended.

After system definition, you can specify a different buffer size for individual logical links by using the type-2 command UPDATE MSLINK NAME(*linkname*) SET(BUFSIZE(*new_bufsize*)). The buffer sizes for individual logical links follow the same specification requirements as buffer sizes specified on the MSPLINK macro.

You can change the value specified on the BUFSIZE= keyword by using the type-2 UPDATE MSPLINK SET(BUFSIZE(*bufsize*)) command.

DDNAME=

The ddname of the JCL statement that describes this physical connection. This operand is required for CTC link types and is invalid for MTM and VTAM link types.

If the CREATE MSPLINK command is used, the DDNAME is allocated dynamically.

Each name must begin with an alphanumeric character. The following names cannot be used as DD names:

DFSRESLB	IMSLOG	IMSTFMT	MSDBINIT
DUMP	IMSLOGR	IMSUDUMP	PRINTDD
IEFRDER	IMSLOGR2	LGMSG	PROCLIB
IEFRDER2	IMSLOG2	MSDBCP1	QBLKS
IMSACB	IMSMON	MSDBCP2	SHMSG
IMSDBL	IMSRDS	MSDBDUMP	
IMSDILIB	IMSSPA		

LCLICON

For TCP/IP links, specifies the IMSplex name of the local IMS Connect instance that manages TCP/IP communications for this physical link. The name specified on the LCLICON parameter must match the name specified on the MEMBER parameter of either the MSC statement or the IMSplex statement in the IMS Connect configuration PROCLIB member (HWSCFGxx). The name specified on the LCLICON parameter must start with an alphabetic character and can be 1- to 8-alphanumeric characters long.

LCLPLKID

For TCP/IP links, specifies the name used by IMS Connect to identify this physical link. The name specified on the LCLPLKID parameter of the MSPLINK macro must match the name specified on the LCLPLKID parameter of the MSC statement that defines the physical link to the local IMS Connect instance that is managing TCP/IP communications for this link. The name specified on the LCLPLKID must start with an alphabetic character and can be 1 to 8 alphanumeric characters long.

MODETBL=

Specifies the name of the VTAM logon mode table entry (logon mode name) containing the SNA bind parameters to be used when a session is established for this terminal.

With MODETBL=, you can have a system definition specification for referencing an entry other than the default entry in the user VTAM logon mode table. Normally, the terminal operator specifies this mode table entry name when logging on to a terminal; this result was not possible, however, from the IMS master terminal because IMS initiated the session.

If MODETBL= is not specified at system definition, no functional or operational change affects the user.

If MODETBL= is specified at system definition, the specified entry name is used.

You can display the current MODETBL name for each assigned logical link by using either the / DISPLAY LINK command or the QUERY MSLINK command. You can override the MODETBL name by using:

- The LOGON APPLID entry by the remote terminal operator
- The VARY ACT, LOGON= command by the network terminal operator
- The /RST or the /CHANGE command by the master terminal operator
- Either the type-2 command UPDATE MSPLINK or UPDATE MSLINK through the Operations Manager API

The MODETBL= parameter is required for the IMS master terminal if the VTAM default mode table has not been configured specifically for the device to be used as the IMS master terminal.

Specifying MODETBL on the MSPLINK macro circumvents the requirement to specify the mode table entry when logging on to terminals that always require specification of the same mode table entry name.

If the terminal being defined is in another domain (that is, a cross-domain resource), the MODETBL parameter does not have to be specified.

Related reading: See z/OS Communications Server: SNA Programming for additional information.

NAME=

For TCP/IP and VTAM physical link types, identifies the remote IMS system at the other end of this physical link.

For a TCP/IP physical link, specify the IMS ID of the remote IMS system.

For a VTAM physical link, specify the VTAM node name of the remote IMS system.

This keyword is required for VTAM and TCP/IP physical link types and is invalid for other link types.

For VTAM MSC physical links, NAME= must be the same as the label on the VTAM APPL statement for the remote system (that is, the minor node name). If the VTAM MSC physical link is communicating with an XRF complex, the node name must be the VTAM USERVAR associated with the partner IMS/XRF complex. If the ACBNAME parameter of the VTAM APPL statement is not specified, NAME= is the same as the application identification (APPLID=) specified on the IMS COMM macro statement in the remote system.

You can change the value specified on the NAME= keyword by using the type-2 IMS command **UPDATE MSPLINK command**.

OPTIONS=

The Session Outage Notification facility only, specifies automatic session restart on all logical links associated with physical links. The default is NOASR. ASR or NOASR in the MSLINK macro overrides ASR definitions on the MSPLINK macro.

To display the current ASR option you can use the type-1 command /DISPLAY. To change the current ASR option you can use either of the following commands:

- The type-1 command /CHANGE
- The type-2 command UPDATE MSPLINK NAME(*msplinkname*) SET(ASR(OFF|ON))

ASR works only if both sides of the link are using the ASR option.

SESSION=

For TCP/IP and VTAM physical link types only, specifies the number of parallel sessions that can be active for the physical link. Valid values are from 1 to 999. The default is 1.

With a large SESSION value, you can dynamically assign more logical links to the physical link than were originally assigned during system definition. The SESSION value can be increased at system startup by using JCL. For instructions, see the keyword NLXB described in [“Environments that support IMS.SDFSRESL procedures” on page 518](#).

Because a given number of logical parallel sessions uses the same amount of storage for control blocks and buffers as would the same number of physical links, allocating many parallel sessions can use an excessive amount of common storage area. Predetermine how much common storage area you want to use.

You can change the value specified on the SESSION= keyword by using the type-2 UPDATE MSPLINK SET(SESSION(*session*)) command.

TYPE=

Defines the type of physical link being described. Valid parameters are CTC, MTM, TCPIP, and VTAM.

With the MTM type link, you can have more than one IMS system running in the same z/OS system without a hardware link.

Related tasks

[“Defining IMS-to-IMS TCP/IP connections for MSC” on page 312](#)

Defining IMS-to-IMS TCP/IP connections for MSC requires defining MSC and IMS Connect and enabling a minimally configured IMSplex at each end of an MSC link.

[Determining optimum MSC link buffer sizes \(Communications and Connections\)](#)

NAME macro

The NAME macro statement defines a logical terminal name (LTERM) that is associated with a physical terminal.

The LTERM can be specified as the IMS master terminal if the associated physical terminal is a 3270 display terminal, SLU 1, or SLU 2. The terminal must be nonswitched. If the terminal is a SLU 1, both the input (ICOMPT) and the output (COMPT) component designations must refer to the first physical component. The first physical component of a SLU 1 terminal must be a console if it is to be defined as the IMS master terminal.

For SLU 1 terminals, the NAME macro statement also defines the data set at the terminal to receive output for corresponding components defined in the TERMINAL macro statement as USERDS1.

For LU 6.1 nodes, the position of the NAME macro within the system definition macro set determines whether LTERM allocation is fixed or dynamic.

If the allocation of LU 6.1 logical terminals is to be predefined (fixed), the NAME macro statement must follow the TYPE and TERMINAL macro statements, and the SESSION parameter must be equal to 1 (by specification or default).

If the allocation of LU 6.1 logical terminals is to be dynamic, the NAME macro statement must follow the SUBPOOL macro statement, and the SESSION parameter must specify a valid value in the range 1 through 255. The default is 1.

- [“Dynamic definition” on page 465](#)
- [“Supported environments” on page 465](#)
- [“Syntax” on page 466](#)
- [“Positional parameters” on page 466](#)
- [“Keyword Parameters” on page 468](#)
- [“Sample NAME macro JCL” on page 468](#)

Dynamic definition

You can define remote LTERMs dynamically by using the CREATE LTERM command, instead of defining them statically with the system definition NAME macro.

Supported environments

The NAME macro can be used in the DB/DC and DCCTL environments.

Syntax

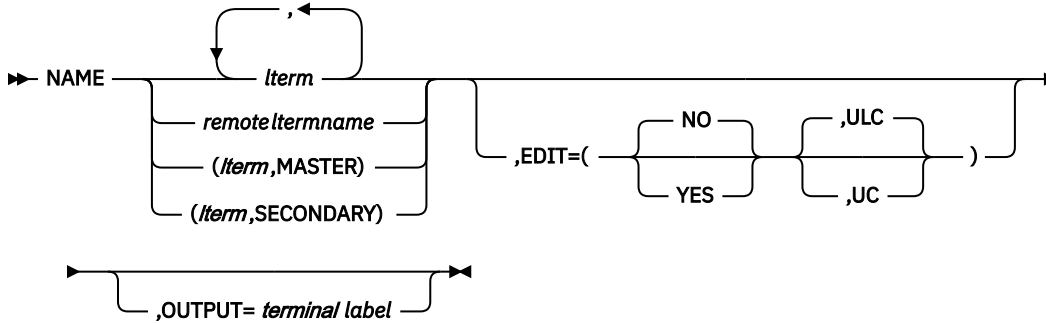

Master terminal

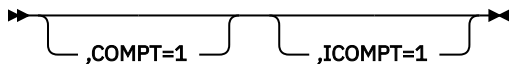

3601 workstation

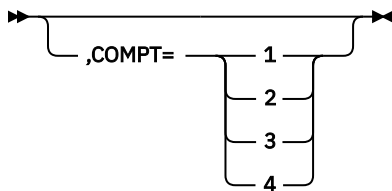

3275 terminal



SLUTYPE1, SLUTYPEP, LUTYPE6 terminals

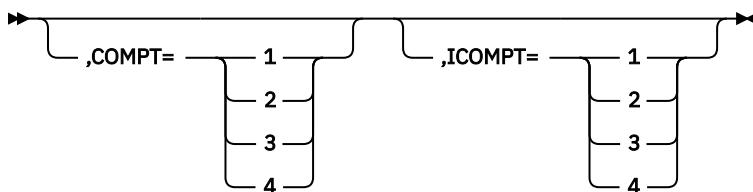

Positional parameters

lterm

Specifies one or more 1- to 8-character names for logical terminals associated with previously defined physical terminals. The name can contain only alphanumeric characters, that is, the letters A through Z, digits 0 through 9, and national characters #, \$, and @. WTOR and DFSMTCNT are invalid *lterm* names. The entered name cannot begin with the character sequence INQU. Logical terminal names, transaction codes, and MSNAME link names, collectively, cannot contain duplicates. This operand is required. For further restrictions, refer to ["Resource naming rules"](#) on page 397.

If you enter the operand as a sublist with the keyword MASTER as a second parameter, the entered name is the identifier of the IMS master terminal.

If you enter the operand as a sublist with the keyword SECONDARY as the second parameter, the entered name is the identifier of the IMS secondary master terminal.

The IMSID is a reserved keyword and cannot be used as a master or secondary master LTERM name.

One logical terminal in the system must be specified as the master terminal. The logical terminal chosen as the master terminal cannot be on a switched LINEGRP. It must be one of the following types:

- 3270 display terminal
- Terminal defined as either SLUTYPE1 or SLUTYPE2

It must also be the console component if the terminal is defined as SLUTYPE1.

One logical terminal can be specified as the secondary master terminal. This logical terminal cannot be on a switched line group. It must be one of the following types:

- A 328x physical terminal
- A terminal defined as SLUTYPE1
- A terminal in a line group defined as a SPOOL

You can specify multiple LTERMs per TERMINAL macro. For example:

```
NAME LTERMA, LTERMZ
NAME LTERMA, LTERMX, LTERMZ
```

For IMS to designate data and commands as having originated at a master terminal, you must specify the first LTERM as MASTER. For example, for IMS to use master terminal default command security for commands entered from the master terminal, specify the first LTERM as MASTER:

```
NAME (LTERMA, MASTER), LTERMX, LTERMZ
```

However, to specify a master terminal and to prevent IMS from designating data and commands as having originated at a master terminal, such as to bypass default command security and use some other form of security such as RACF command security, specify an LTERM other than the first LTERM for the terminal as MASTER:

```
NAME LTERMA, (LTERMX, MASTER), LTERMZ
```

For terminals with multiple NAME LTERMs defined, system error message responses are sent to the logical terminal name that is lowest in the collating sequence, unless the terminal is an input-only terminal. For input-only terminals, the system responses go to the first assigned logical terminal OUTPUT= terminal.

remote lterm name

Specifies a one- to eight-character name for a logical terminal associated with a physical terminal defined in a remote IMS system. The name can contain only alphanumeric characters. WTOR and DFSMTCNT are invalid logical terminal names. The name cannot begin with the character sequence INQU. For further restrictions, refer to [“Resource naming rules” on page 397](#). No other operands are meaningful for a remote logical terminal; if provided, they are interpreted as comments only.

Usage information

If the IMS master terminal is specified as a SLU 1, the designation of a secondary master terminal is optional. The master secondary terminal can be specified if the logical terminal's associated physical terminal is SLU 1. The terminal must be nonswitched. If the terminal is a SLU 1, both the input (ICOMPT) and the output (COMPT) component designations must refer to the first physical component. The first physical component of a SLU 1 can be either a console or a printer if it is to be defined as the IMS secondary master terminal.

If the IMS master terminal is specified as a 3270 display terminal, a secondary master terminal is required, and must be specified for a 328x, associated physical terminal.

If the IMS master terminal is specified as SLU 2, you must specify a secondary master terminal in a preceding NAME macro for a 328x, SLUTYPE1, or SPOOL associated physical terminal.

If other physical terminals are defined on the same communication line as the primary or secondary master terminal, then special restrictions apply to the use of the /CHECKPOINT and /IDLE commands in the IMS system.

The Message Format Service (MFS) special master terminal formatting is only available for 3270 display terminals specified with a screen size of 24 x 80.

For output purposes, the COMPT operand associates the specified logical terminal with a specific component in a 3601, SLU 1, or SLU P terminals, or LU 6.1 nodes. The COMPT operand is valid only for these terminal types.

If two or more sessions are defined on the SESSION parameter, dynamic allocation must be used.

Consider using dynamic rather than fixed allocation for one parallel session (SESSION=1). This permits all subpools to be available for dynamic allocation to that session.

Keyword Parameters

To find which parameters apply to your IMS configuration, refer to [“Selecting the appropriate macros to define your system”](#) on page 5.

COMPT=

Specifies the output component associated with this logical terminal. If this is the master terminal, the COMPT= operand value must be either not specified or 1.

For 3601 work stations, you can specify 1, 2, 3, or 4.

COMPT= cannot be specified for NTO devices.

EDIT=

Specifies whether the logical terminal user-supplied edit routine DFSCNTE0 is to be used when routing a message to this logical terminal. The logical terminal edit routine is loaded as a stand-alone module during IMS initialization only if at least one NAME statements specifies EDIT=YES during system definition. If IMS initialization does not detect any static LTERMS defined with EDIT=YES, then DFSCNTE0 is not loaded. If ULC is specified, output is transmitted as received. If UC is specified, output is translated to uppercase before transmission.

The logical terminal edit routine DFSCNTE0 is not supported for ETO logical terminals.

ICOMPT=

Specifies the input component associated with the terminal defined in the previous TERMINAL macro. If this is the master terminal, the ICOMPT= operand value must be either not specified or 1.

For SLU 1, SLU P, or LU 6.1 terminal systems, you can specify 1, 2, 3, or 4. These values relate to the components specified in the preceding TERMINAL macro statement.

For secondary logical units defined as SLUTYPE1, if the first component is a console, the default is 1; if the first component is a printer, no default exists. For terminals defined as SLUTYPEP or LUTYPE6, the default is 1.

ICOMPT= cannot be specified for NTO devices.

OUTPUT=

Specifies a terminal that is to be used as the output terminal for this logical terminal name. This is specified by entering the label of the TERMINAL macro defining the desired terminal. The referenced TERMINAL statement must occur before this NAME statement. OUTPUT= cannot be specified for VTAM terminals. OUTPUT= cannot be used with response mode, Fast Path, or conversational transactions.

A split input/output LTERM is not applicable to ACF/VTAM terminals.

Sample NAME macro JCL

The following figure is an example of the order of the macros for fixed and dynamically allocated subpools:

```
TYPE          UNITYPE=LUTYPE6TYPE      UNITYPE=LUTYPE6
TERMINAL      SESSION=1                 TERMINAL  SESSION=(1-255)
NAME          ltrmname                   .
                                           .
```

```

VTAMPOOL
SUBPOOL  NAME=SBPLNAME
NAME     ltrmname

```

RTCODE macro

The RTCODE macro specifies the routing codes that identify the application program that is named in the preceding APPLCTN macro statement.

The RTCODE macro statement can be used one or more times with the APPLCTN macro statement that defines an IMS Fast Path application program. A TRANSACT macro statement that specifies an IMS Fast Path-exclusive transaction automatically generates an RTCODE macro statement with a routing code identical to the transaction code.

If you do not include this macro during stage 1 system definition, no warning is issued, and it is assumed that you define your routing codes dynamically using CREATE RTC and UPDATE RTC commands.

A routing code that is specified on an RTCODE macro must not be a duplicate of a Fast Path-exclusive transaction code, but can be a duplicate of a Fast Path potential transaction code. Invalid duplicate routing codes can be identified by using the NAMECHK option of the IMSCTRL macro.

The Fast Path Input Edit/Routing exit routine (DBFHAGU0) must be used to route the transaction to the correct Fast Path application program.

Routing codes can be added, changed, or deleted by a MODBLKS system definition. However, new routing codes can only be added if the online system to which they are to be added already has Fast Path defined for it.

Dynamic definition

To dynamically define the routing codes that identify application programs previously defined, you can use the CREATE RTC command and the UPDATE RTC type-2 commands. The following table compares the RTCODE macro keywords and the equivalent CREATE and UPDATE command keywords used for dynamic definition. Default values are shown in **bold**.

RTCODE macro keyword	CREATE UPDATE RTC keyword equivalent
Previous APPLCTN macro statement	PGM(<i>name</i>)
CODE= <i>routing code</i>	NAME(<i>name</i>)
INQUIRY= NO YES	INQ(N Y)

Supported environments

The RTCODE macro can be optionally used in an IMS DB/DC and IMS DBCTL environment.

Syntax

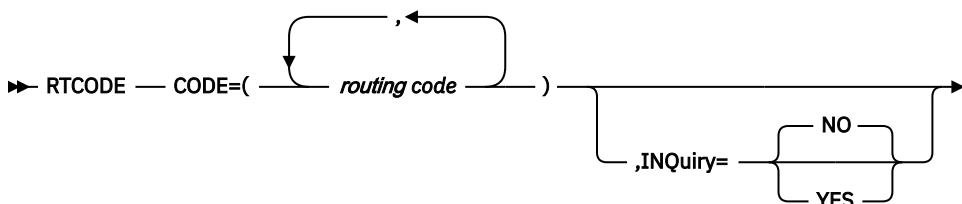

Positional parameters

The RTCODE macro does not include positional parameters.

Keyword parameters

To find which parameters apply to your IMS configuration, refer to [“Selecting the appropriate macros to define your system” on page 5](#).

CODE=

Specifies the one- to eight-character alphanumeric routing code, or list of routing codes. The first character must be either a letter or a digit. Routing codes can be duplicates of either transaction codes or logical terminal names, but each must be unique within the set of routing codes.

INQUIRY=

Specifies whether (YES) or not (NO) any message associated with the routing code specified on the same RTCODE macro statement is an inquiry transaction. The default is NO. INQ=YES should be specified only for transactions that do not cause a change to a database. Programs are prohibited from issuing Insert, Delete, or Replace calls to a database when processing a transaction defined as INQ=YES.

Usage information

If you do not include this macro during stage 1 system definition, it is assumed that you dynamically define your route codes using the CREATE RTC and UPDATE RTC commands. See [Table 56 on page 469](#) for more information.

An APPLCTN macro statement that defines a message-driven Fast Path application program should be followed by at least a TRANSACT macro statement or an RTCODE statement.

SUBPOOL macro

The SUBPOOL macro statement, when used in a VTAM macro set, is a delimiter between groups of NAME macro statements to create LU 6.1 LTERM subpools.

At least one NAME macro statement must be defined within the VTAMPOOL; however, it is valid to define one or more subpools with no NAME statements. This definition creates a reserved subpool to which no terminals are allocated until reassigned there with the /ASSIGN command.

The subpools must be named to be used in IMS commands or session initiation requests. The LU 6.1 subpool names, specified on the required NAME keyword operand of the SUBPOOL macro statement, must follow standard z/OS naming conventions and must be unique with respect to other LTERM subpool names within the VTAMPOOL. The subpool names must be unique among themselves, but need not be unique to other names used in an IMS system, such as LTERM names and transaction names. These subpools can only be used with statically defined ISC terminals. They cannot be used with ETO terminals.

If parallel sessions are defined in your system, at least one subpool must be defined.

Recommendation: Define at least one subpool for each parallel session defined in your system. Additional subpools can be defined if you desire.

For a session to be brought up, a subpool must be allocated to it. Thus, if you have defined two parallel sessions in your system and only one subpool, only one session can be brought up at any one time.

Dynamic definition

You cannot dynamically define LU 6.1 LTERM subpools.

Supported environments

The SUBPOOL macro can be used in the DB/DC and DCCTL environments.

Syntax



Positional parameters

The SUBPOOL macro does not include positional parameters.

Keyword parameters

To find which parameters apply to your IMS configuration, refer to [“Selecting the appropriate macros to define your system”](#) on page 5.

MSGDEL=

Used for VTAM LU 6.1 devices and specifies which message types IMS should discard for this terminal. The default is SYSINFO.

SYSINFO | **NONIOPCB**

SYSINFO, the default, specifies that IMS should discard DFS059 TERMINAL status messages for this terminal and also DFS3650 for SLU P devices.

NONIOPCB specifies that IMS should discard the following message types destined for this terminal:

- Message switches
- Messages inserted by an application program to an alternate PCB
- /BROADCAST messages
- DFS059 TERMINAL status messages

NAME=*subpoolname*

Used for VTAM LU 6.1 devices and names the LU 6 subpool.

TERMINAL macro

Use the TERMINAL macro statement to define physical and logical characteristics of VTAM nodes and non-VTAM communication terminals.

The NAME macro statements that follow a TERMINAL macro statement supply the logical terminal names that are associated with the physical terminal at system definition. Whichever terminal name is designated in the first NAME macro statement that follows a TERMINAL macro statement becomes the response or input/output logical terminal.

A TERMINAL macro statement that defines terminals connected to a switched communication line must not be immediately followed by a NAME macro statement.

All Fast Path-eligible terminals must operate in response (forced or transaction) mode. Where applicable, the PAGDEL option must be specified (or used by default) for these terminals.

Message Format Service (MFS) can be used in an IMS Fast Path configuration.

The TERMINAL macro statement can be specified without operands if the terminal is a printer, punch, tape, or disk.

All non-VTAM data communication specifications must precede the VTAM macro set in your IMS system definition stage 1 input deck. You receive a stage 1 output warning message if the VTAM macro set is not the last physical set. If an MSC macro set is part of your system definition, it must precede the VTAM

macro set, or your system definition does not complete. To add VTAM support, you must specify either an ON-LINE or ALL system definition on the IMSCtrl macro statement.

For VTAM terminals, the default values shown for operands of the TERMINAL macro statement are ignored if these operands are specified on the TYPE macro statement.

If system definition statements from previous releases of IMS are being used, TERMINAL macro definitions from the previous releases are valid for this release. The TERMINAL keywords in this topic must be used for terminals newly supported with this release of IMS and for terminals that use new IMS terminal functions.

The TERMINAL macro statement can be used to define secondary logical units type 1, type 2, type 4, and type P, logical unit type 6.1, and NTO devices. These are designated on the TYPE macro as UNITYPE=SLUTYPE1, SLUTYPE2, SLUTYPEP, LUTYPE6, and NTO, respectively.

By specifying SLUTYPE1 on the TYPE macro, you can define an appropriate configuration of console, bulk printer, disk, and card reader/punch. The 3767 and 3770 nonprogrammable terminals must be defined to IMS as SLUTYPE1.

SLUTYPE2 must also be specified for display devices attached to a 3274 or 3276 Control Unit that is operating in SNA mode.

Related reading: For 3270/SLUTYPE2 dynamic terminals that are not defined by the TERMINAL macro, see [MFS Device Characteristics Table utility \(DFSUTB00\) \(System Utilities\)](#).

By specifying SLUTYPEP on the TYPE macro, you can define 3600 terminals and 3790 or later programs using the Host Communication Facility. This support extends full IMS functional capabilities to user-written programs within the controller and includes the MFS Distributed Presentation Management (DPM) function. The support is in addition to current support for 3600 and 3790 user-written programs.

By specifying LUTYPE6 on the TYPE macro, you can define a logical unit type 6 node such as IBM CICS Transaction Server for z/OS, another IMS, or a user-written program. This node can communicate with IMS as an SNA primary or secondary half-session.

For logical units type 6, the log write-ahead option, as specified by the LTWA and NLTWA parameters on the TERMINAL macro statement, need no longer be specified, because log write-ahead occurs automatically. Therefore, although this parameter can be retained for compatibility with previous releases, if it is specified, it is ignored by IMS.

By specifying NTO on the TYPE macro, you can define NTO devices. NTO support provides a non-SNA start/stop terminal interface to VTAM for 3101, TTY, and TTY-compatible devices. The TERMINAL macro statement keyword PU= permits you to designate the type of terminal being defined to use NTO support.

Related reading: For further information about SLU P and LU 6.1 (ISC), see *IMS Version 15.4 Communications and Connections*.

The TERMINAL macro statement can also be used to define terminals belonging to a Finance Communication System such as the 3600 Finance Communication System or the 4700 Finance Communication System. Finance Communication System components for devices specified as UNITYPE=3601 or as UNITYPE=FINANCE on the TYPE macro statement can be defined on the TERMINAL macro statement using either specific 3600 definitions or generic FINANCE terminal definitions. The code generated to support the terminal is identical regardless of whether the terminal is specified as UNITYPE=3601 or UNITYPE=FINANCE.

By specifying SLUTYPE2 on the TYPE macro, you can define 3277 terminals, Models 1 and 2, operating under control of the 3790/3270 Data Stream Compatibility. Under this support, the 3277 Model 2 can be defined as the IMS master terminal; the Model 1 is not supported as an IMS master terminal. This support is in addition to current support for the 3600 and 3790 user-written programs. The 3790 can be defined appropriately as SLUTYPE1, SLUTYPE2 or as a subset of FINANCE.

- [“Dynamic definition” on page 473](#)
- [“Supported environments” on page 473](#)
- [“Syntax” on page 473](#)
- [“Positional parameters” on page 483](#)

- [“Keyword parameters” on page 483](#)

Dynamic definition

You cannot dynamically define the physical and logical characteristics of VTAM nodes and non-VTAM terminals.

Supported environments

The TERMINAL macro can be used in the DB/DC and DCCTL environments.

Syntax

All Non-VTAM terminals

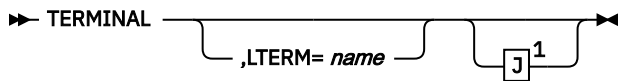

Notes:

¹ Spool terminal

All VTAM terminals

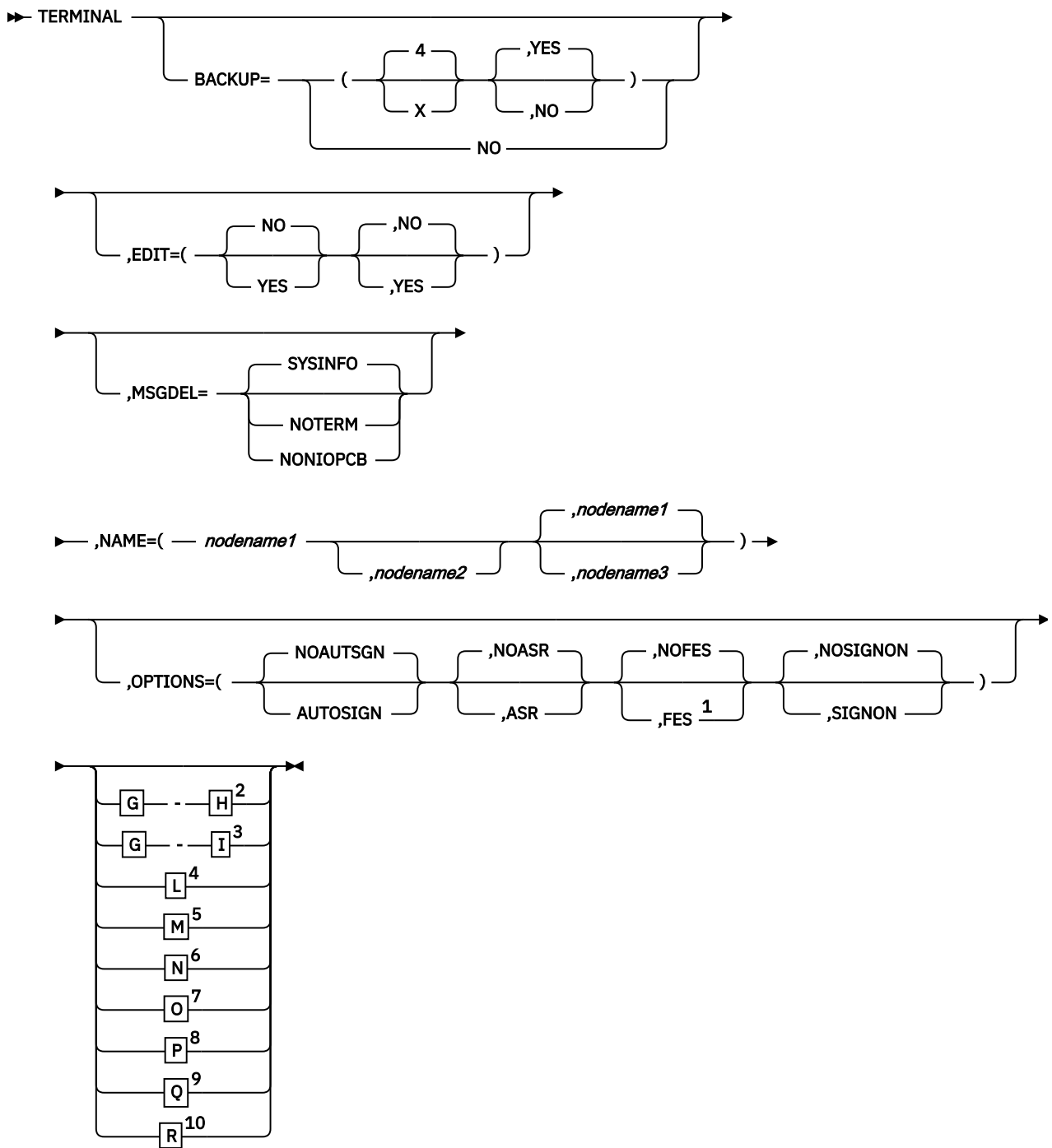

Notes:

- 1 FES not valid for LU 6 terminals
- 2 3270 local terminal
- 3 3270 remote terminal
- 4 Finance workstation (If UNITYPE=FINANCE on the TYPE macro)
- 5 3600 workstation (If UNITYPE=3601 on the TYPE macro)
- 6 SLU 1 terminal
- 7 NTO device
- 8 SLU 2 terminal
- 9 SLU P terminal
- 10 LU 6 terminal

G (all 3270 terminals)

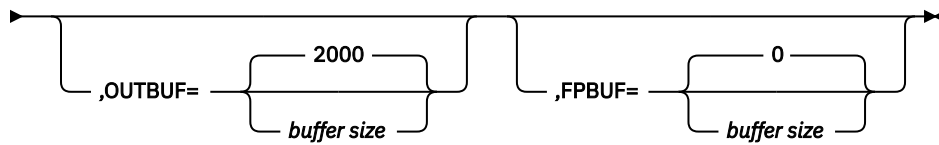
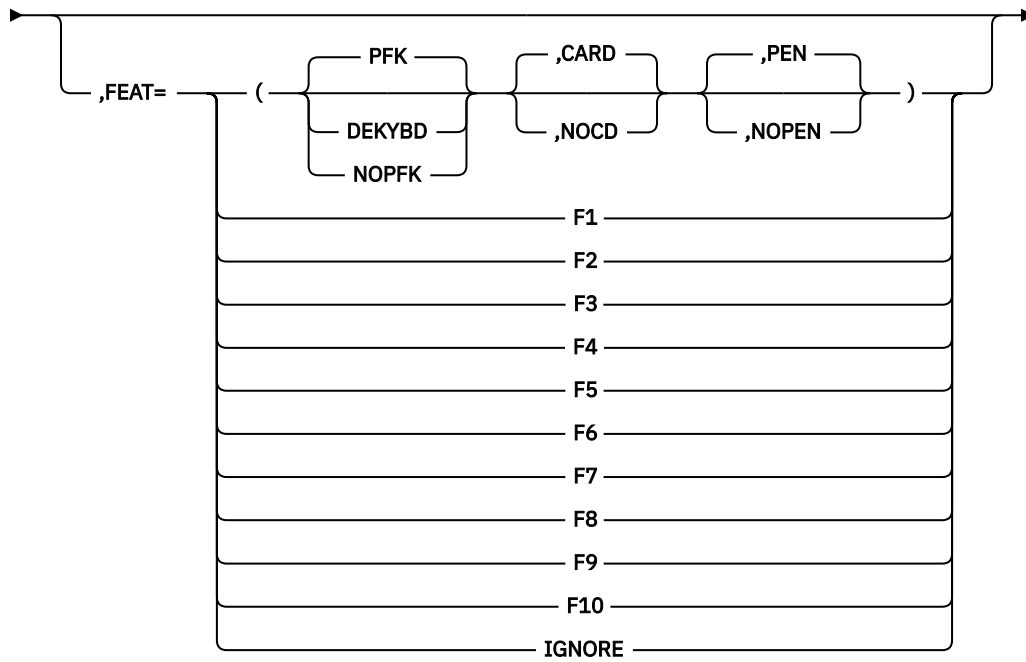
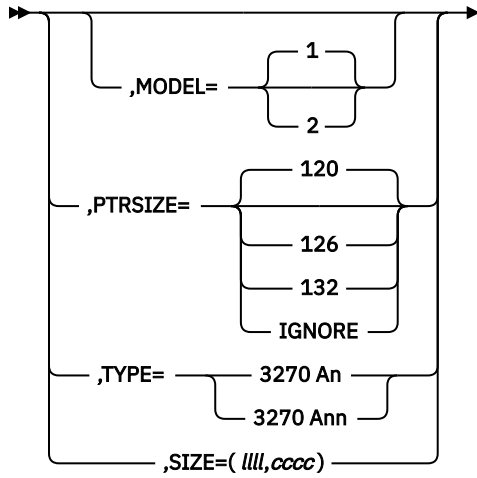

H (3270 local terminals)

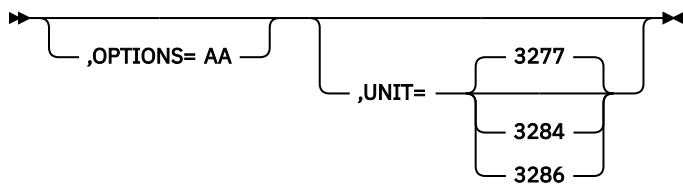

AA

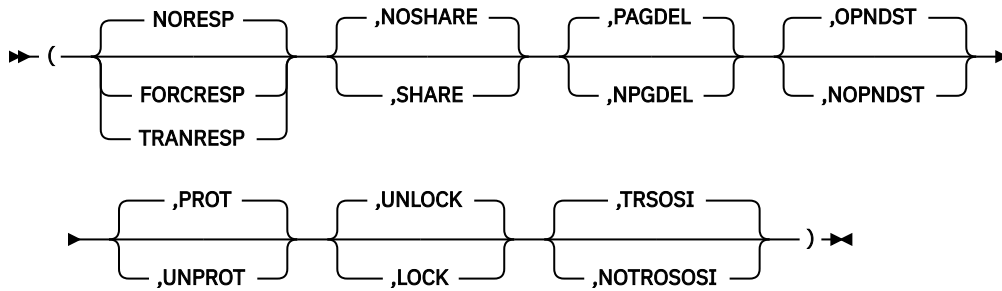

I (3270 remote terminal)

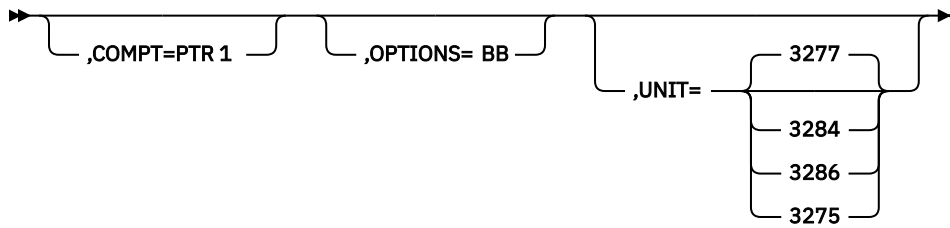

BB

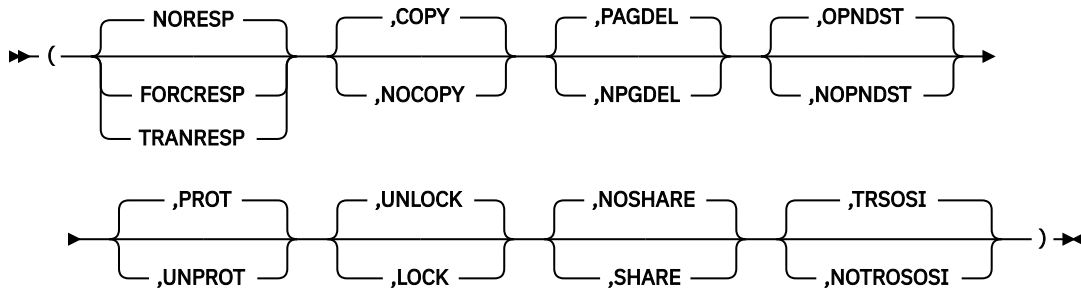

J (spool terminal)

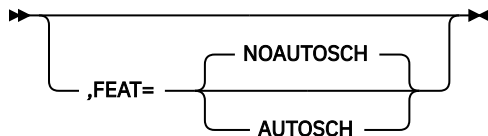

L (finance workstation (UNITYTYPE=FINANCE on the TYPE macro))

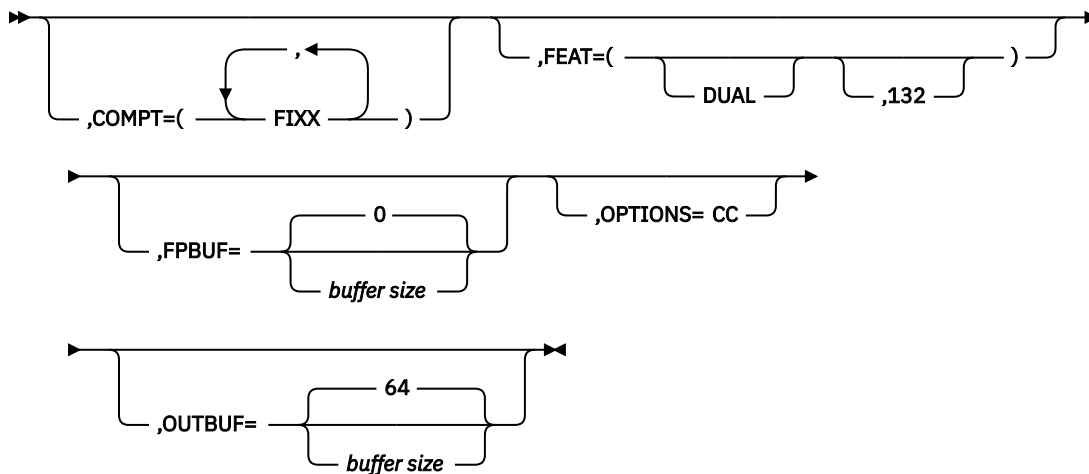

CC

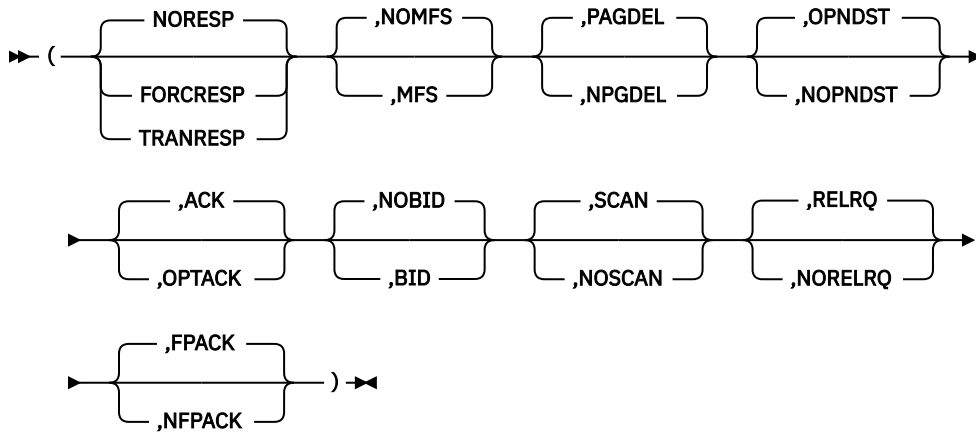

M (3600 workstation (if UNITYPE=3601 on the TYPE macro))

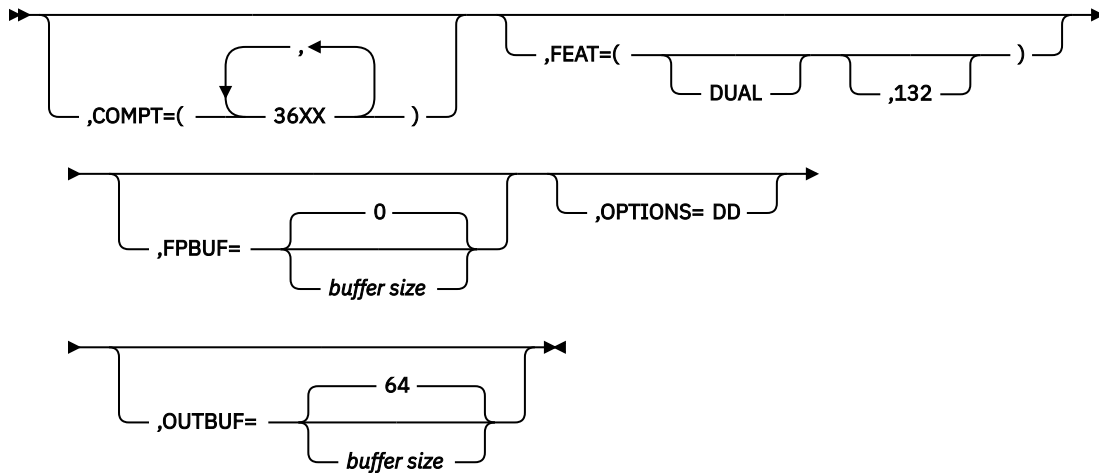

DD

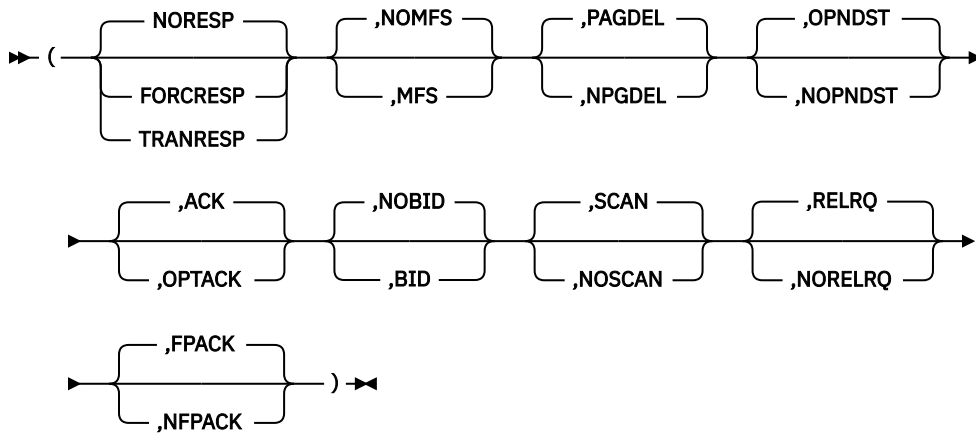

N (SLU 1 terminal)

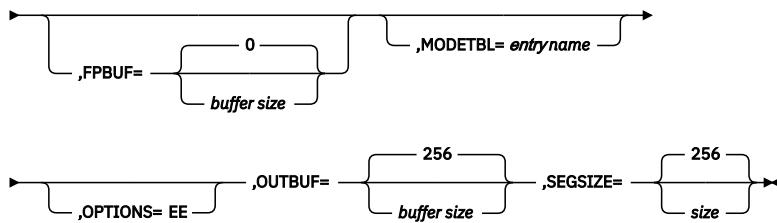
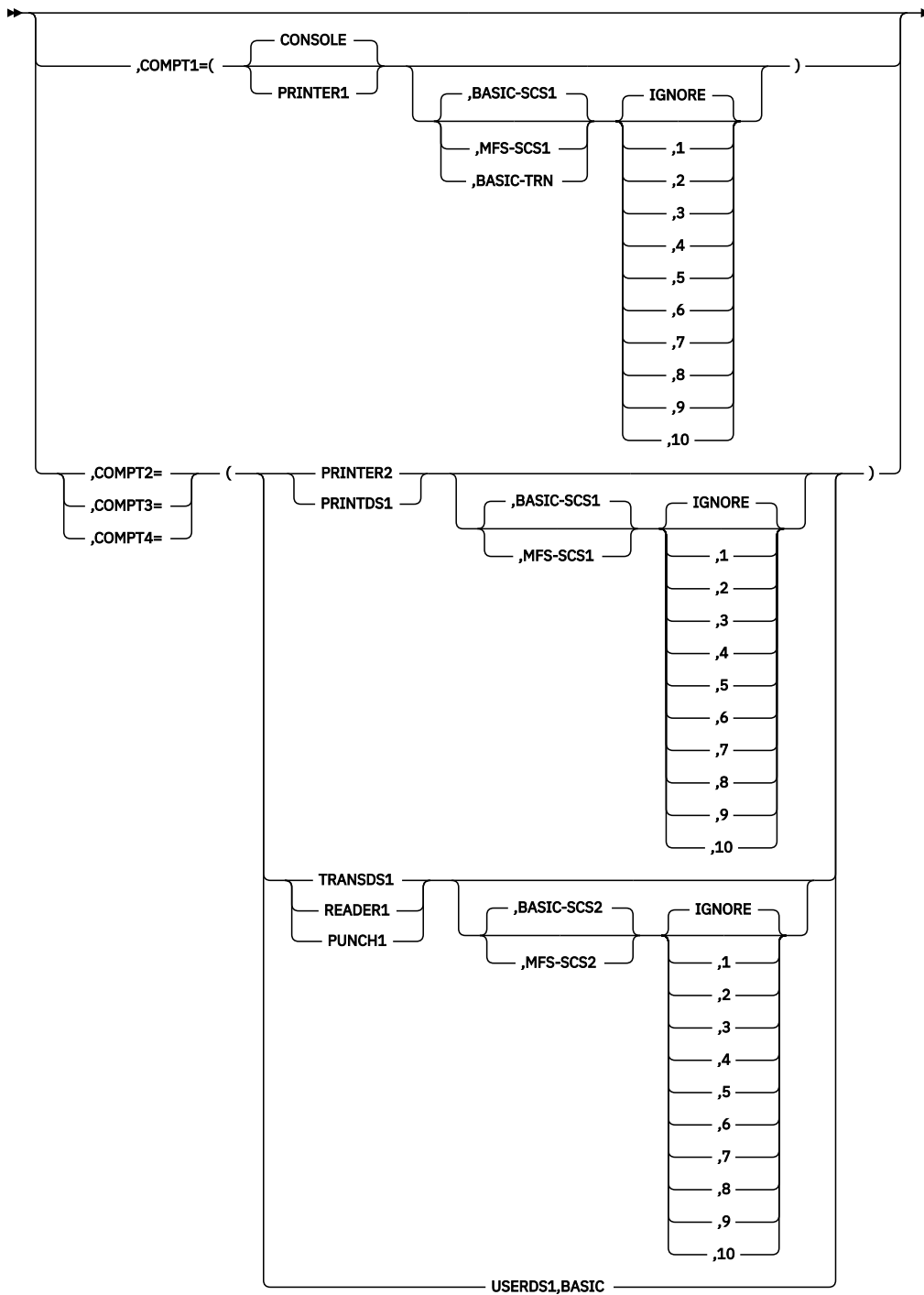

EE

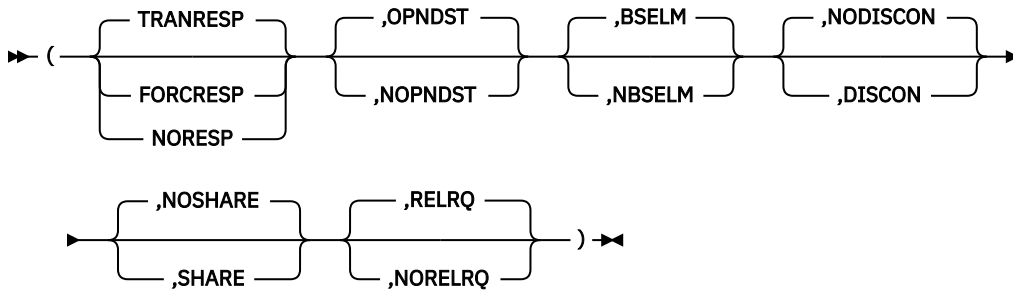

O (NTO device)

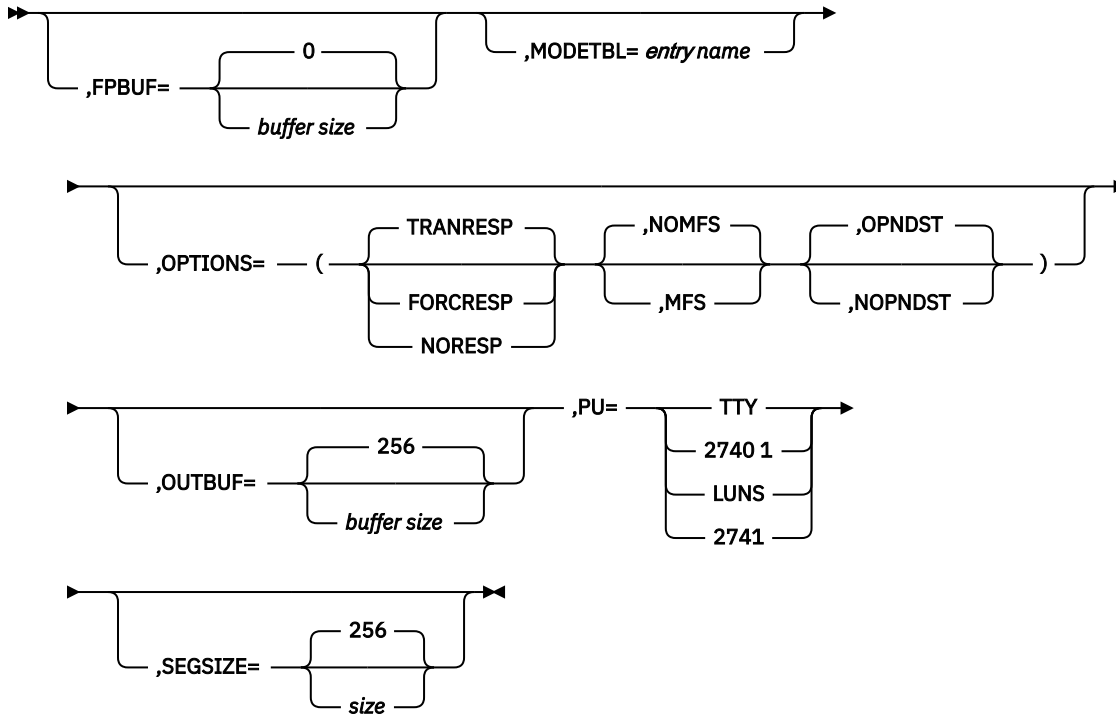

P (SLU 2 terminal)

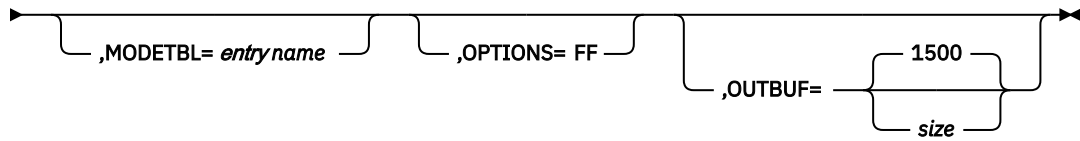
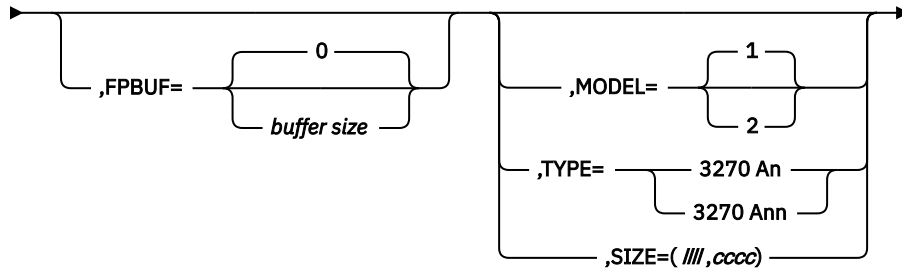
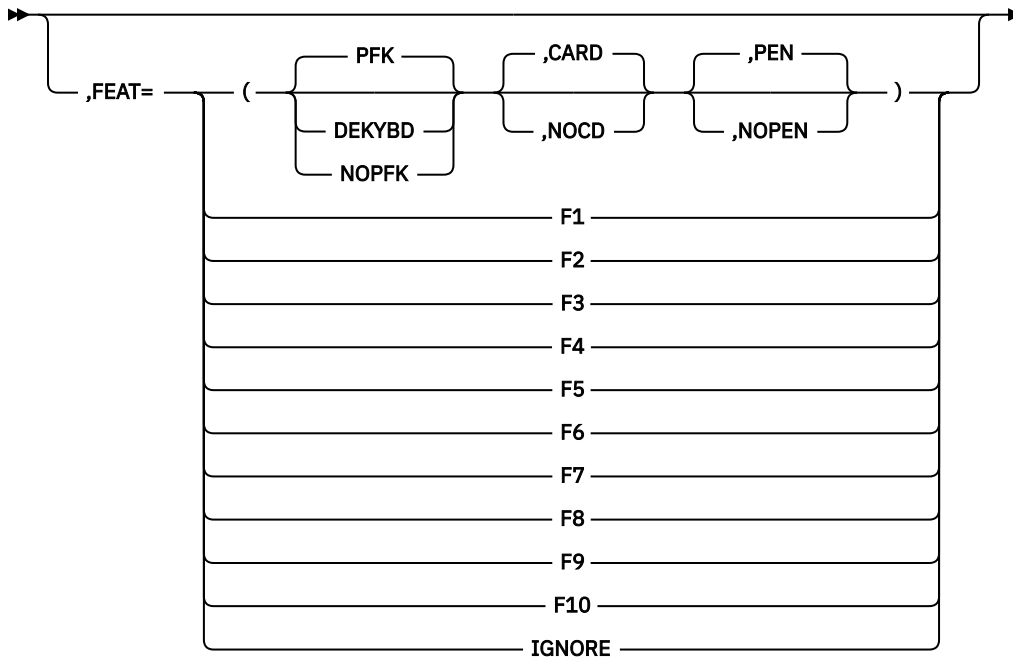

FF

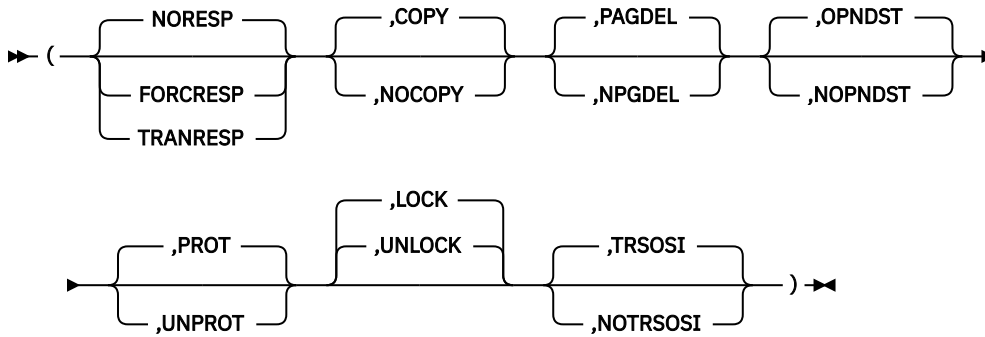

Q (SLU P terminal)

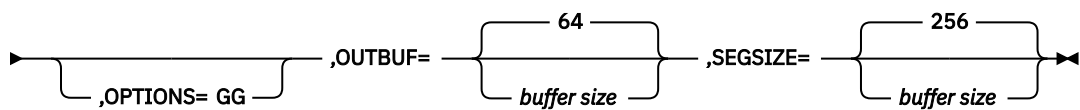
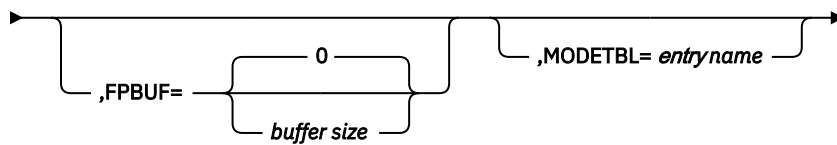
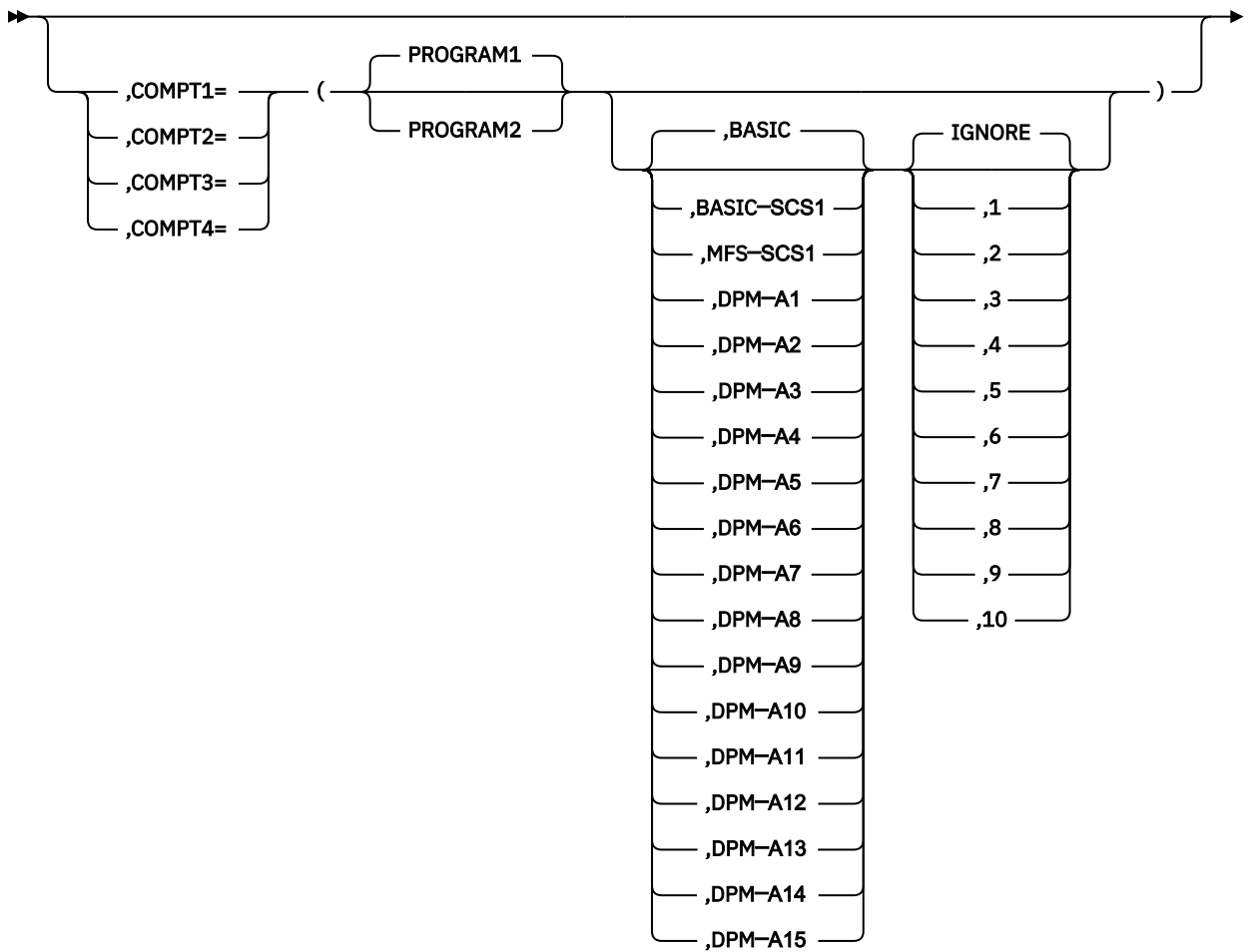

GG

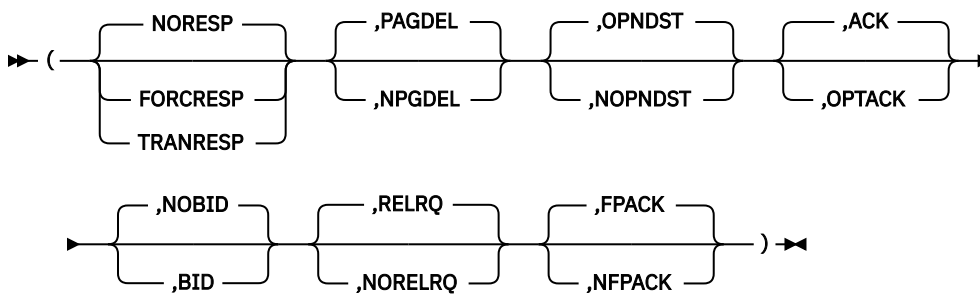

R (LU 6.1 terminal)

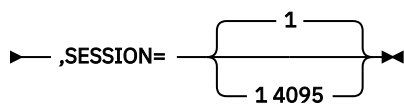
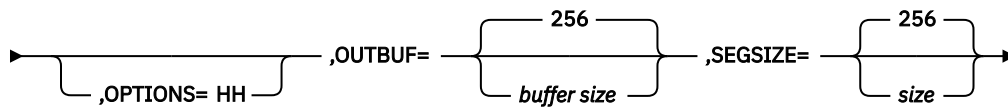
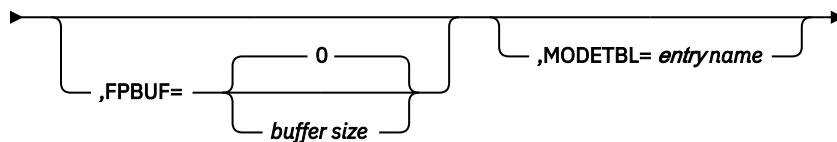
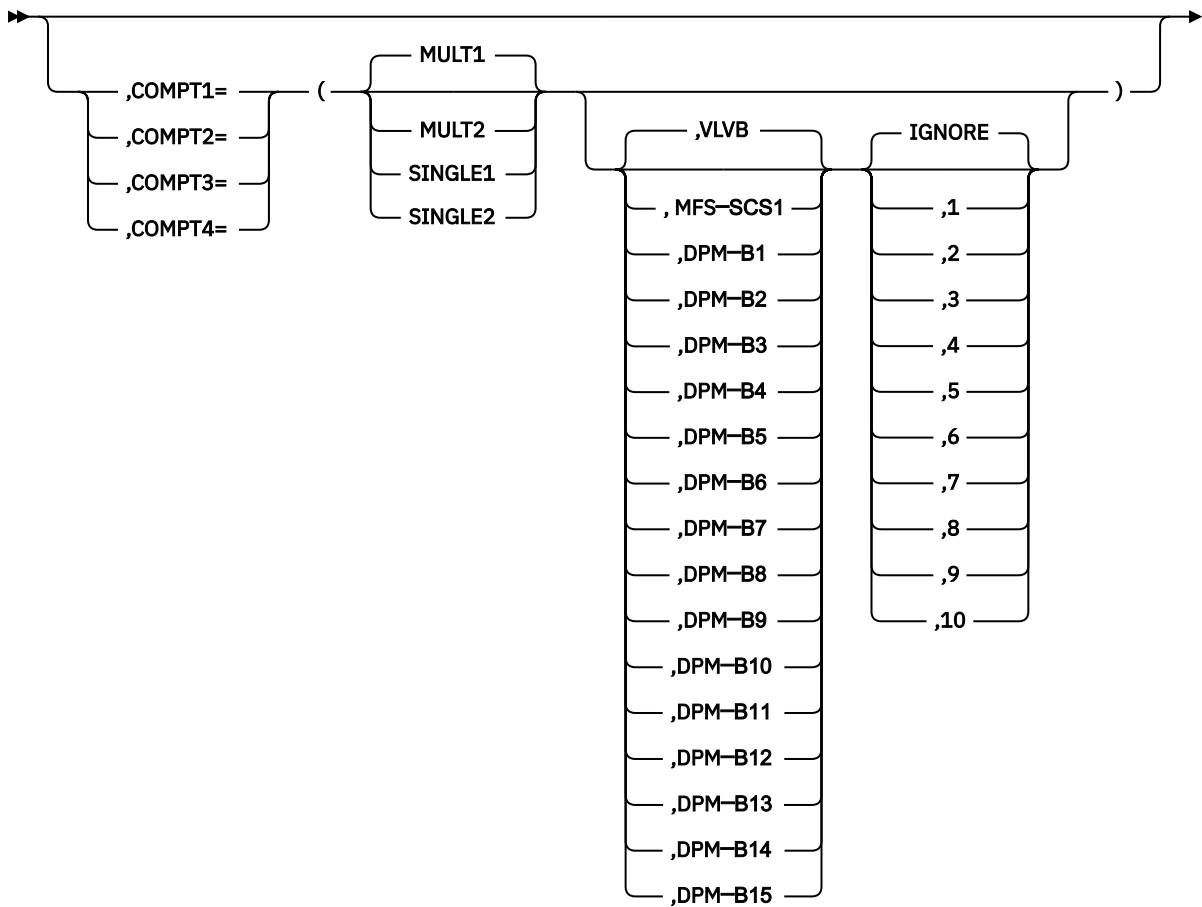

HH

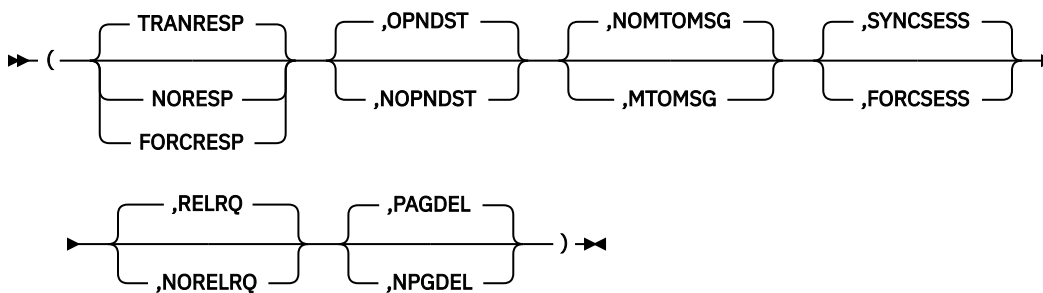

Label Field

If any subsequent NAME macro statement refers to this TERMINAL macro statement in its OUTPUT keyword, a label must be specified for the TERMINAL macro statement.

Positional parameters

The TERMINAL macro does not include positional parameters.

Keyword parameters

To find which parameters apply to your IMS configuration, refer to [“Selecting the appropriate macros to define your system” on page 5](#).

BACKUP=

Specifies (for an XRF complex) control of the automatic restart or session switching (VTAM) after takeover. Use only when HSB=YES is specified on the IMSCTRL macro.

X is a numeric integer from 1 to 7, inclusive, that specifies the priority for reestablishing the session. The default is 4 if either the keyword or the parameter is omitted. NO suppresses session recovery of the terminal at takeover.

Although requests to VTAM are prioritized by IMS, the active requests can be completed in any order because of internal VTAM conflicts and pacing.

The second parameter is only used with VTAM terminals. It determines whether the backup system is to attempt to establish a backup session to the terminal when the active request establishes a session. Backup sessions are not valid for UNITYPEs 3270, LU6, and NTO. If this parameter is specified as YES for these UNITYPEs, it is ignored. If it is not specified, the default is NO. The default for this second parameter is YES when either the keyword or the parameter is omitted. Specifying NO for this parameter suppresses the establishment of a backup session.

BUFSIZE=

Specifies the size of the output buffer. The value specified here cannot exceed the value specified on the preceding LINE macro statement. The default is 120.

COMPT=

Specifies components of this terminal. This operand is valid only for 3600 terminals. For terminals specified as UNITYPE=3601 or FINANCE on the TYPE macro, COMPT= describes the components that compose this workstation. A maximum of four terminal cans can be defined. Acceptable values for components are:

36DS or FIDS

3604 display or 4704 keyboard/display

36DS3 or FIDS3

3604 display, model 3

36DS4 or FIDS4

3604 display, model 4

36DS7 or FIDS7

3604 display, model 7

36JP or FIJP

3610/3612 journal printer or 4710 receipt validation printer

36PB or FIPB

3611/3612 passbook printer

36FP or FIFP

3618 line printer

36MS or FIMS

Magnetic strip encoder

36CT or FICT

3614 customer transaction facility (a component of FINANCE)

One 36DS, 36DS3, 36DS4, 36DS7, or 36CT (or equivalent components specified as FIDS, FIDS3, FIDS4, FIDS7, or FICT) can be specified per workstation. Multiple components of the same type (excluding 36DS, 36DS3, 36DS4, and 36DS7 or equivalent Fxxx components) can be specified. The order in which components are specified determines the value placed in the COMPT field of the Finance Communication System output message header.

COMPT1=, COMPT2=, COMPT3=, COMPT4=

- For SLU 1 terminals:

Defines the component types and processing associated with terminals defined as SLUTYPE1. A maximum of four components can be defined. For each component, three subparameters can be defined: media, edit processing, and features.

You can assign a number to a set of user-defined features (such as printer size, vertical forms control, horizontal tabs on a printer, and logical record length on a diskette) and tell MFS what these features are. IGNORE can be used to specify that all features (or any designated feature) are to be ignored.

Component 1 must be either CONSOLE or PRINTER1. Components 2, 3, and 4 must be PRINTER2, PRINTDS1, TRANSDS1, READER1, PUNCH1, or USERDS1.

If no components are specified, the default is COMPT1=(CONSOLE,BASIC-SCS1).

The first subparameter (media) of the second, third, or fourth components has no default.

If BASIC-SCS1, BASIC-SCS2, BASIC, or BASIC-TRN is specified as the second subparameter (editing), the third subparameter (feature) cannot be specified. If MFS-SCS1 or MFS-SCS2 editing is specified as the second subparameter, the default is IGNORE for the third subparameter.

The following values can be defined:

CONSOLE (BASIC-SCS1 or MFS-SCS1)

Identifies the presence of a console keyboard and a printer. Either this component or PRINTER1 must be (and can only be) specified first in a sublist, because all error messages are routed to this destination. This component uses SCS1 data streams. This can be the only component specified if the secondary logical unit type 1 is a 3767.

CONSOLE (BASIC-TRN)

Identifies a SLU 1 terminal whose input data does not conform to SCS (SCS1 or SCS2) protocols. IMS processes the data without editing, translating, or deleting characters following the destination and password fields. No MFS editing is supported.

This form of transparency support differs from SCS2 transparency support in that BINDPSB1=BINTRNDS in the SLU 1 bind image need not be set (and has no effect if set), and in that IMS does not scan the input data stream for transparency control characters (X'35') to identify transparent fields.

PRINTDS1

Identifies the presence of a print data set or the SYS.INTR data set for the SLU 1 programmable model. This component uses SCS1 data streams.

PRINTER1

Identifies the presence of 3784, 3284, 3286, or similar printers. This component or console must be (and can only be) specified first in a sublist, because all error messages are routed to these destinations. This component uses SCS1 data streams.

PRINTER2

Identifies the presence of a SLU 1 printer. This component uses SCS1 data streams.

PUNCH1

Identifies the presence of a 3770 card output device. This component uses SCS2 data streams. Card records do not span RU boundaries.

READER1

Identifies the presence of a 3770 card input device. This component uses SCS2 data streams.

TRANSDS1

Identifies the presence of an input component consisting of the SLUTYPE1 transmit data set. This component uses SCS2 data streams. TRANSDS1 can be specified only once as a component of a particular terminal.

USERDS1

Identifies the presence of the user's sequential data sets for output and input. MFS support is not available for this component. The data stream on output is undefined; the inbound data stream is the same as the transmit data set data stream.

If multiple USERDS1 components are defined on the same TERMINAL macro statement, all user data set (UDS) input appears to be from the first UDS defined. Also, unless the CHNG call is used by the IMS Message Processing Program, all output is sent to the output component associated with the first UDS defined. (See the COMPT parameter of the NAME macro statement.)

If MFS-SCS1 or MFS-SCS2 data streams are specified, MFS-SCS1 or MFS-SCS2 formatting is used for messages processed by MFS.

- For SLU P nodes:

Defines the component types and processing (including distributed presentation management for MFS) associated with a node defined as SLUTYPEP, and indicates that the component is represented by a user-written program.

Up to four components can be specified; for each component, up to three subparameters can be specified. If the component is not specified, the default is COMPT1=(PROGRAM1,BASIC). Components 1, 2, 3, and 4 must be either PROGRAM1 or PROGRAM2. If component 2, 3, or 4 is present and takes all defaults (PROGRAM1,BASIC), at least one of the default subparameters must be specified so that the presence of the component can be recognized.

The first subparameter is the media type coded as PROGRAM1 or PROGRAM2.

If PROGRAM1 is specified, IMS does not assume component protection for this component and might send consecutive messages without waiting for intervening input requests. When using MFS, component protection can be accomplished for messages which use MFS with paging options in MFS control blocks defined as DEV TYPE=DPM-A01...DPM-A15 or DPM-A1...DPM-A15.

If PROGRAM2 is specified, IMS assumes component protection and does not send consecutive messages without intervening input requests.

The second subparameter specifies the type of editing to be provided by IMS for input to and output from user-written programs.

If BASIC is specified, no deblocking occurs on input, and MFS is not used on output or input.

If DPM-A01...DPM-A15 or DPM-A1...DPM-A15 is specified, no deblocking occurs on input, and the MFS DPM function can be used on output or input. To define DPM for this component, code DPM-An, where "n" is a decimal number from 1 to 15. When MFS is to be used, this operand must match an MFS DEV TYPE=DPM-An statement within the MFS definitions.

If BASIC-SCS1 is specified, SCS1 data streams are used. MFS is not available on output or input.

If MFS-SCS1 is specified, SCS1 data streams are used, and MFS is available.

The third subparameter specifies a user-defined feature code. The designated feature is used to select an MFS format—MFS-SCS1, DPM-A01...DPM-A15, or DPM-A1...DPM-A15—with matching feature specification. IGNORE can be used to specify that an MFS format (SCS1 or DPM-An) with the FEAT=IGNORE operand of the DEV statement is to be selected.

The third subparameter cannot be specified if BASIC or BASIC-SCS1 is specified for the type of editing (second subparameter).

- For LU 6.1 nodes:

Defines the SNA send/receive and bracket protocols to be used during asynchronous IMS output to LU 6.1 nodes. The MFS distributed presentation management (DPM) facility can be defined as available selectively by component.

The first, second, and third subparameter are specified independently of one another.

The first subparameter (MULT1, MULT2, SINGLE1, SINGLE2) indicates the output protocol to be used and the number of messages to be sent on output. These subparameters are defined as follows:

- MULT1—Multiple messages or empty queue ends the bracket
- MULT2—Multiple messages or empty queue causes the flow to be returned to the other half-session
- SINGLE1—A single message or empty queue ends the bracket
- SINGLE2—A single message or empty queue causes the flow to be returned to the other half-session

The default is MULT1.

Related reading: Refer to *IMS Version 15.4 Communications and Connections* for information about whether to specify a component as SINGLE1, SINGLE2, MULT1, or MULT2. *IMS Version 15.4 Communications and Connections* also includes information about the characteristics of SINGLE1, SINGLE2, MULT1, MULT2.

The second subparameter (VLVB/DPM-Bn) indicates whether MFS is available for the component and whether the data blocking algorithm is to be used. VLVB indicates variable-length, variable-blocked format is to be used in place of MFS for both input and output. DPM-Bn indicates that MFS DPM is available for both input and output from that component on a message-by-message basis. The default is VLVB. You should not specify the DPM-B(xx) operand for the XRF/ISC link. If DPM-B(xx) is specified, a G732 warning message is issued, and the default value of VLVB is assumed.

The third subparameter, a number 1 - 10, specifies a user-defined feature code. The designated feature is used to select an MFS format. IGNORE can be used to specify that an MFS format with the FEAT=IGNORE operand of the DEV statement is to be selected. The default is IGNORE. (If the second subparameter is specified as VLVB, the third subparameter cannot be specified.)

EDIT=

The first parameter specifies whether (YES) or not (NO) the user-supplied physical terminal output edit routine specified in the TYPE or LINEGRP macro statement is to be used for this workstation. The default is NO.

The second parameter specifies whether (YES) or not (NO) the user-supplied physical terminal input edit routine specified in the TYPE or LINEGRP macro statement is to be used for this workstation. The default is NO.

FEAT=

(If the system definition statements from previous releases of IMS are used, TERMINAL macro statements from previous releases are valid for this release.)

- For nonswitched or local 3270 terminals:

The first subparameter specifies whether a DEKYBD (Data Entry Keyboard) or PFK (Program Function Keys) is available on this 3275 or 3277 terminal. PFK and DEKYBD are not valid, and NOPFK (no Program Function Keys) is forced for 3284 and 3286 terminals. The default is PFK.

The second subparameter specifies whether the Operator Identification Card Reader is available (CARD) or not (NOCD) on this 3275 or 3277 terminal. CARD specification is not valid, and NOCD is forced for 3284 and 3286 terminals. The default is CARD.

The third subparameter specifies whether (PEN) or not (NOPEN) the Selector Pen is available on this 3275 or 3277 terminal. PEN specification is not valid and NOPEN is forced for 3284 and 3286 terminals. The default is PEN.

- For terminals defined as SLUTYPE2:

The comments for nonswitched and local 3270 terminals apply equally to terminals defined as SLUTYPE2.

- For all 3270 Terminals:

IGNORE can be specified if the presence or absence of the value does not affect terminal operation within IMS.

If IGNORE is not specified, the default values assumed for any omitted subparameters are PFK, CARD, and PEN, respectively.

- For all 3270 terminals (except for the printer component of the 3275) and secondary logical units type 2 (SLU 2):

F1, F2...F10 specify terminal features that the user designates to correspond to each integer. The same number is used for any given feature during both system definition and MFS processing. This specified integer is used instead of, and not in addition to, other feature specifications.

If you are using the same MFS format for the 3180 and 3290, Fn must have different values for the 3180 and 3290. These same values must be coded on the corresponding FEAT=Fn parameter of the MFS DEV statements.

- For 3275 printer components:

FEAT=F1...F10 is not a valid specification for 3275 printer components (that is, devices specified as UNIT=3275 and COMPT=PTR1).

- For 3284 and 3286 units:

F1...F10 specify terminal features that the user designates to correspond to each integer. The same number is used for any given feature during both system definition and MFS processing. This specified integer is used instead of, and not in addition to, other feature specifications.

Specifications of FEAT=F1...F10 and PTRSIZE are mutually exclusive for the 3284 and 3286 devices. If PTRSIZE= is specified, FEAT= is invalid. If FEAT= is specified, no default PTRSIZE is assumed.

Also, FEAT=IGNORE is invalid for these devices. PTRSIZE=IGNORE is used instead.

The use of a particular specification for F1...F10 should be directly related to a particular printer line size and should be consistently used for printers having that line size and identical attributes throughout your system definition.

Example: FEAT=F5 might be used to define printers with a line size of 126 print positions and color, FEAT=F6 for printers with a line size of 126 print positions but without color, and FEAT=F7 for printers with a line size of 120 or 132.

- For UNITYPE=3601 or FINANCE and COMPT=36FP:

DUAL indicates the presence of the DUAL forms control feature, and 132 indicates the presence of the extended print line feature.

- For SPOOL Terminals:

If FEAT=AUTOSCH, the print utility is automatically scheduled when the spool lines are stopped, when a spool data set fills, or when IMS is initialized. If FEAT=NOAUTOSCH (the default), the MTO must schedule the print utility.

FPBUF=

Specifies the Fast Path terminal buffer size for the following terminal types: 3270 (VTAM), 3601, SLU 1, SLU 2, NTO, SLU P, and LU 6.1. FPBUF provides the system default for the EMH buffer if the EMHL parameter is not specified. FPBUF=0 means that the terminal is not eligible for Fast Path processing. FPBUF=0 is the default. This specification can also be used to override an FPBUF= default on the TYPE macro statement. If the terminal is eligible for Fast Path transaction processing, the minimum value that can be specified is 12. The maximum value is 30 720. The value specified must not be greater than the logical record length of the long message queue data set specified in the RECLNG= parameter of the MSGQUEUE macro.

This keyword is optional and cannot be specified on ETO terminal descriptors. See the RECLNG parameter of the MSGQUEUE macro for further information.

LTERM=

Specifies a logical terminal name for this TERMINAL statement. This name is used to check input terminal security for this terminal. The NAME macro referred to must precede this TERMINAL statement. When this operand is present, the TERMINAL statement cannot be followed by a NAME statement.

This operand is required for READER terminals. For example, a previously defined TERMINAL statement defined a 3270 remote terminal and was followed by the name ABLE. In addition, assume that this TERMINAL statement refers to a READER terminal that is an input-only device. All input security for the READER terminal is checked against the security characteristics assigned to ABLE.

This operand cannot be specified for NTO devices and is not supported for ACF/VTAM terminals.

When a list of LTERMs is defined under the previous TERMINAL statement to which reference is made, only the first LTERM name is selected from that list. If an attempt is made to select other than the first, IMS ignores the name chosen and assigns the value of the first name listed.

Example:

TERMINAL	ADDR=E2
NAME	LTERM1
NAME	LTERM2
NAME	LTERM3
TERMINAL	ADDR=E4, LTERM=LTERM2

In this example, IMS treats the second TERMINAL statement as though it reads LTERM=LTERM1.

MODEL=

Specifies the terminal model number for terminals with screen sizes of 480 (Model 1) or 1920 (Model 2) characters. Terminals with screen sizes other than 480 or 1920 characters are defined using the TYPE and SIZE keyword parameters. The default is 1. The model number specified for a 3277 for which OPTIONS=COPY is specified must be less than or equal to the model number specified for any candidate printer. The MODEL and TYPE/SIZE keyword parameters are mutually exclusive.

MODETBL=

Specifies the name of the VTAM logon mode table entry (logon mode name) that contains the SNA bind parameters to be used when a session is initiated by the MTO or through the /OPNDST command.

This function allows a system definition specification for referencing an entry other than the default entry in the user's VTAM logon mode table. Normally, the terminal operator specifies this mode table entry name when logging on to a terminal; this is not possible, however, from the IMS master terminal because IMS initiates the session.

With this function, if MODETBL= is not specified at system definition, no functional or operational change affects the user.

If MODETBL= is specified at system definition, the specified entry name is used. The MODETBL can be overridden by:

- The LOGON APPLID entry by the remote terminal operator
- VARY ACT, LOGON= command by the network terminal operator
- /OPNDST, /RST, or /CHANGE command by the MTO

The MODETBL= parameter is required for the IMS master terminal if the VTAM default mode table is not configured specifically for the device to be used as the IMS master terminal.

With MODETBL=, you do not need to specify the mode table entry when logging on to terminals that always require specification of the same mode table entry name.

MSGDEL=

Specifies which message types IMS should discard for this terminal, if it is not the master terminal. The default is NONE for non-VTAM terminals and SYSINFO for VTAM terminals. NONE is ignored for VTAM.

NONIOPCB | NOTERM | SYSINFO | NONE

NONIOPCB specifies that IMS should discard the following message types destined for this terminal:

- Message switches
- Messages inserted by an application program to an alternate PCB
- /BROADCAST messages
- DFS059 TERMINAL status messages

NOTERM specifies that IMS should discard DFS059 TERMINAL status messages and DFS3650 SESSION status messages for this terminal. Do not specify NOTERM for 3601, SLU P, or LU 6.1 VTAM terminals. If NOTERM is specified, a warning message is issued and the specification default is SYSINFO.

SYSINFO specifies that IMS should discard DFS059 TERMINAL status messages for this terminal.

NONE specifies that IMS should not discard any message types for this terminal.

When MSGDEL is specified, the following additional restrictions apply to the reassignment of logical terminals:

- Assignment of a logical terminal to a physical terminal defined as MSGDEL=NONIOPCB can only take place if no messages are in the Q3 (logical terminal's system) or Q4 (other than system) queues, unless that logical terminal is currently assigned to a physical terminal also defined as MSGDEL=NONIOPCB.
- Assignment of a logical terminal to a physical terminal defined as MSGDEL=SYSINFO or MSGDEL=NOTERM can only take place if no messages are in the system queue of the logical terminal, unless that logical terminal is currently assigned to a physical terminal defined as MSGDEL=SYSINFO, MSGDEL=NOTERM, or MSGDEL=NONIOPCB.

An LU 6.1 session can be initiated only if the MSGDEL specifications on both the TERMINAL macro statement and the SUBPOOL macro statement match. An LU 6.1 session is not established, and an error message is issued if these specifications are not identical.

NAME=

Must be the VTAM node name specified during VTAM/NCP definition.

When using XRF and VTAM-supported master terminals, a second node name should be specified for the master terminals. The two node names specify nodes in the two IMS XRF systems. The first is used by the system with HSBID=1 and the second by the system with HSBID=2. If a secondary master is used, it also should have two specifications. For more information about the HSBID parameter, see [“Environments that support IMS.SDFSRESL procedures”](#) on page 518.

The specification of *nodename* corresponds to the HSBID= specification at IMS start up. This means that HSBID=2 uses *nodename2* as the master or secondary master terminal, and uses PASSWD2 (from COMM macro).

When you define an ISC surveillance link between the XRF active and alternate systems, the two node names in the NAME keyword must match the two VTAM application names in the APPLID keyword of the COMM macro.

For an ISC node communicating with an XRF complex, the node name must be the VTAM USERVAR associated with the XRF complex. Defining additional nodes for the actual VTAM APPLIDs of the IMS systems which comprise the XRF complex results in errors during session initiation.

The recommended use of the *nodename* keyword is:

- Use *nodename1* only for DB/TM or DCCTL systems that are non-XRF
- Use *nodename1* and *nodename2* for DB/TM or DCCTL systems using XRF

The default for *nodename3* is the value of *nodename1*

OPTIONS=

Specifies certain communication options associated with this terminal. The OPTIONS= subparameters are not position dependent.

ACK | OPTACK

ACK indicates that recoverable and update transactions must be acknowledged with a definite response 1 (FME) or definite response 2 (RRN). OPTACK allows input messages containing only a begin bracket indicator to be acknowledged by an end bracket indicator on the next output message. A definite response must be requested for recoverable input if ACK is specified, and is optional if OPTACK is specified. The use of OPTACK also affects the sequence number recording for message resynchronization.

Related reading: Additional information about ACK and OPTACK is found in *IMS Version 15.4 Communications and Connections*.

OPTACK is forced for Fast Path-eligible terminals if the value specified for FPBUF is greater than 0. ACK can be specified if BID is not also used. ACK allows a 3600/LUP terminal to add Fast Path without initially recoding the remote terminal program.

BSELM | NBSELM

Specifies whether (BSELM) or not (NBSELM) the backspace character elimination is required for input from a SLU 1 terminal.

COPY | NOCOPY

Specifies whether (COPY) or not (NOCOPY) the copy function is requested for this terminal. Terminals defined with the copy function must have appropriate candidate printers.

Related reading: For a detailed discussion of candidate printers for 3270 terminals, refer to the discussion of controlling output in *IMS Version 15.4 Communications and Connections*.

This subparameter is supported for dynamic SLU 2 terminals, but not for dynamic non-SNA VTAM 3270s.

FPACK | NFPACK

Applies only to 3601/Finance and SLU P terminal types and specifies whether (FPACK) or not (NFPACK) Fast Path output message protocol is to be used, as defined in *IMS Version 15.4 Communications and Connections*.

The Fast Path output message protocol for FPACK normally requires another input (transaction or SNA RTR command), following transmission of the output Fast Path reply message, before any asynchronous output message can be sent. The NFPACK option indicates that standard non-Fast Path protocols are to be used, and allows any asynchronous output message to be sent immediately following acknowledgment of the Fast Path output reply message.

NOASR | ASR

For the Session Outage Notification facility only; specifies automatic session restart (ASR) on a VTAM node. The default is NOASR. Specifying ASR or NOASR on the TERMINAL macro overrides ASR definitions on the TYPE macro for a defined node.

Use the /DIS command to display the current ASR option, and the /CHANGE command to change it.

The ASR option is not supported for nodes that can have XRF backup sessions.

For LUTYPE6 nodes, the ASR option works only if IMS is acting as the primary logical unit (PLU).

NOAUTSGN | AUTOSIGN

AUTOSIGN indicates that IMS automatically signs on to static terminals with the first LTERM name as the user ID, bypassing a password check. The user ID needs to be defined in RACF.

For ISC static terminals, the SUBPOOL name is used as the user ID instead of the LTERM name.

NOAUTSGN indicates that IMS does not automatically sign on to static terminals with the first LTERM name as the user ID. This is the default.

The AUTOSIGN and NOAUTSGN definitions in this macro override those definitions on the TYPE macro.

If you specify AUTOSIGN on the TYPE macro, every subsequent TERMINAL macro after that TYPE macro also specifies AUTOSIGN. You can specify exceptions to the AUTOSIGN specification by specifying NOAUTSGN for particular TERMINAL macros.

NOBID | BID

NOBID indicates that the VTAM BID command is never to be used. BID indicates that the VTAM BID command always precedes output messages that occur while between brackets, regardless of response mode option used.

Before the availability of this option, IMS systems forced the equivalent of NOBID if NORESP was specified, and forced the equivalent of BID if FORCRESP is specified.

NODISCON | DISCON

Determines whether IMS should automatically terminate a session for a terminal defined as SLUTYPE1 when operating in unattended mode. (ATTEND or UNATTEND mode is determined from the logon mode table entry specified to be used during session initiation.) DISCON specifies that IMS should automatically terminate the communication session with the terminal after receiving all immediately available input or sending all available output. NODISCON suppresses that automatic termination. The logon mode table is described in the MODETBL= keyword description.

NOFES | FES

Specifies whether (FES) or not (NOFES) this terminal is capable of front— end switching. The default is NOFES.

To define a terminal as capable of front-end switching, define the front end switch exit routine with the FESEXIT keyword in the IMS startup parameter.

If FES is specified, the FES exit gets control for each input from this terminal.

NOMFS | MFS

Specifies whether (MFS) or not (NOMFS) the Message Format Service (MFS) is to be provided for this terminal. The default is NOMFS.

NOMTOMSG | MTOMSG

Specifies whether (MTOMSG) or not (NOMTOMSG) normal session initiation and termination messages are to be sent to the IMS MTO. The default is NOMTOMSG.

NOSHARE | SHARE

Specifies whether (SHARE) or not (NOSHARE) this printer can be shared between VTAM subsystems. If SHARE is specified, then IMS can issue a SIMLOGON VTAM macro when either of the following occurs:

- Data is queued for this printer.
- The VTAM 3270 PF12 key invokes the internal IMS copy function that selects this terminal, and the terminal is not connected to IMS.

If SHARE is specified, the OPNDST option must also have been selected for this terminal.

If SHARE is specified, a MODETBL entry cannot be specified for cross-domain resources. An entry of ALL X'00' in the VTAM MODETBL indicates to ACF/VTAM that the default session parameters are to be used for this terminal and that the terminal can be defined in any VTAM domain.

If the default option, NOSHARE, is specified, and if IMS releases this terminal to another VTAM application, the IMS MTO must issue an /OPN command, a VTAM VARY command, or a UNIX System Services logon for IMS to reacquire the terminal.

This option is applicable to SLU 1, 3284/86 local, and VTAM 3270 devices only. If UNITYPE=3270 is specified on the TYPE macro statement, UNIT must be a 3284 or 3286 device.

NOSIGNON | SIGNON

For VTAM terminals only, specifies signon verification security processing (SIGNON). The default is NOSIGNON.

The SIGNON and NOSIGNON definitions in this macro override those definitions on the TYPE macro.

Instead of specifying OPTIONS=SIGNON in more than one system definition macro, you can require all static terminals to sign on by specifying a single parameter, SIGNON=ALL, in the DFSDCxxx PROCLIB member.

Related reading: For more information about the SIGNON keyword, see [“DFSDCxxx member of the IMS PROCLIB data set” on page 736.](#)

OPNDST | NOPNDST

Applies only to VTAM terminals and specifies whether (OPNDST) or not (NOPNDST) the /OPNDST command is valid for this node. The default for all terminal types except NTO is that /OPNDST is valid.

The default value for NTO devices is NOPNDST. Either NOPNDST, the default value, or OPNDST is valid for nonswitched NTO devices. When using switched NTO devices, NOPNDST must be specified or accepted by default, because these devices must be logged on by an operator. An error results if OPNDST is specified for switched NTO devices.

The NOPNDST option is used to prevent the /OPNDST command from being used to start a session between IMS and a VTAM terminal.

This option does not apply to a VTAM terminal specified in the NAME macro as MASTER (the IMS master terminal), because that terminal is automatically opened.

PAGDEL | NPGDEL

Specifies whether (PAGDEL) or not (NPGDEL) automatic page deletion is to be specified for this terminal. This option applies to 3270 terminals, SLU 2 terminals, SLU P nodes, and to 3601 workstations using MFS. PAGDEL is the default option, but the LU 6.1 nodes default is NPGDEL.

When the last physical page of the last logical page of the message is sent, the message is dequeued no matter which parameter is specified.

PAGDEL should be specified for terminals used in an interactive or conversational manner. If input from the terminal or node is normally followed by a response to the terminal or node, PAGDEL should be specified.

NPGDEL is provided for terminals that produce many input messages to which no response is made. When NPGDEL is specified, input from a paged message is responded to by IMS with the first page of that same message. Any application program response is queued.

PROT | UNPROT

Specifies whether (PROT) or not (UNPROT) the terminal display is protected after each page of a message. If PROT is specified, the protected status of the terminal depends upon the unprotected screen mode option on the DSCA keyword of the MFS DEV statement or the SCA keyword of the MFS MFLD statement. This keyword applies only to 3270 display terminals and secondary logical units type 2 (SLU 2).

RELRQ | NORELRQ

Specifies whether (RELRQ) or not (NORELRQ) IMS is to release this terminal upon request from other VTAM subsystems. If NORELRQ is specified, requests by other VTAM subsystems for this terminal are not honored. The MTO must intervene to reassign this terminal to another VTAM subsystem. If RELRQ, the default, is specified, then IMS releases this terminal to other VTAM subsystems upon request.

This option is applicable to devices specified on the TYPE macro statement as UNITYPE=3601, FINANCE, SLUTYPE1, SLUTYPEP, and LUTYPE6, in addition to 3284 and 3286 printers.

NORELRQ is forced for 3277, SLU2, and NTO terminals.

SCAN | NOSCAN

Specifies whether (SCAN) or not (NOSCAN) IMS should edit 3601 device-control sequences (such as SELECT, POSITION, and WRITE TRANSPARENT) that would otherwise be split across

two transmissions when a non-MFS formatted output segment must be split into multiple transmissions.

If an MFS-formatted output segment must be split across two transmissions, IMS edits 3601 device-control sequences (SELECT and POSITION) that would otherwise be split across two transmissions even if the NOSCAN option is specified.

Related reading: See *IMS Version 15.4 Communications and Connections* for additional information.

SYNCSESS | FORCSESS

Specifies when session initiation is to be completed.

- SYNCSESS specifies that session initiation is to be completed only when session restart modes (message sequence numbers) agree.
- FORCSESS specifies that session initiation is to be completed regardless of the agreement of session restart modes.

The default is SYNCSESS.

TRANRESP | NORESP | FORCRESP

TRANRESP specifies that the transaction code definition should be referred to determine whether response mode should be used. All Fast Path-eligible terminals operate in response mode—either TRANRESP or FORCRESP.

- TRANRESP is the default value for 3767, 3770 switched and station-control terminals, and for terminals defined as SLUTYPE1, NTO, or LUTYPE6.
- NORESP specifies that response mode is not to be allowed for this terminal. NORESP is the default for 3270, and 3601 terminals, and terminals defined as SLUTYPE2 and SLUTYPEP. NORESP is not compatible with Fast Path.
- FORCRESP specifies that response mode is to be forced for all transactions entered from this terminal.

For VTAM terminals, the combined specification of FORCRESP and NPGDEL is not recommended. Also, if MSGTYPE=RESPONSE is specified on the TRANSACT macro statement for these terminals, the combined specification of TRANRESP and NPGDEL is not recommended.

The keyboard of a display terminal defined with no automatic page deletion (NPGDEL) can become locked during execution if operating in terminal response mode. NPGDEL specifies that the current output message is not to be dequeued at the time of input. However, with terminal response mode, input is inhibited until the current output message is dequeued and the terminal response mode is reset. Thus, a terminal receiving multiple pages of output and defined with the combined specification of FORCRESP and NPGDEL might require master terminal intervention to reset the terminal response mode.

TRSOSI | NOTRSOSI

Specifies whether IMS translates the shift-out/shift-in (SO/SI) characters for MFS editing. The SO/SI characters indicate which characters are used for EGCS terminals. The default of TRSOSI should be used for non-EGCS terminals. This keyword applies only to 3270 terminals and type 2 secondary logical units (SLU2).

UNLOCK | LOCK

Specifies whether IMS is to unlock the terminal keyboard and reset the modified data tags after an MFS bypass.

- UNLOCK specifies that MODNAME=DFS.EDTN unlocks the terminal keyboard and resets the modified data tags
- LOCK specifies that an application program assumes responsibility for unlocking the terminal keyboard and resetting the modified data tags.

This keyword applies only to 3270 terminals and type 2 secondary logical units (SLU2).

OUTBUF=

Specifies the size of the IMS output buffer to be used for the workstations that are identified in this parameter description. The OUTBUF value indicates the maximum size of IMS message segments that are sent from IMS to the workstation in a single transmission.

For VTAM SNA devices, a single transmission represents a transmission from IMS to VTAM. For these devices, the output message is blocked (chained) based on the OUTBUF value and might result in multiple transmissions for a single message.

For VTAM non-SNA devices, IMS sends the message in a single transmission. No blocking or chaining is performed.

If MFS bypass is used, the OUTBUF value must be large enough to contain the entire output message. If the message that is inserted by the IMS application exceeds the OUTBUF value, the message is rejected by IMS. If MFS is used to edit the output message, the OUTBUF value is ignored and the message is sent regardless of its length. When sending to a printer, the OUTBUF value must be equal to or greater than the segment size, but less than 4096 bytes.

IMS also uses the OUTBUF value to set the transmission services usage field (byte 11) in the bind parameter. If this value is specified incorrectly, it might cause the device to reject the bind parameter. The value specified, plus the size of any routing information later appended by VTAM, must be less than the maximum message size specified for VTAM and its related NCPs. The output buffer size is calculated as follows for:

3270: Record size. The range of values that can be specified is 256 through 30720 bytes. The default is 2000 bytes. The actual hardware buffer capacity should be considered when creating the OUTBUF calculation. The hardware buffer maximum might be less than the default of 2000 bytes. For a device that is not a SNA 3270, OUTBUF is used only if you are using MFS bypass. Otherwise, OUTBUF is ignored.

Related reading: For information about devices attached to a local 3274 control unit, see *3274 Control Unit Description and Programmer's Guide*.

3601 or FINANCE: Record size plus header. (Header is 3 bytes if MFS is not used or 29 bytes if MFS is used.) The range of values that can be specified is 64 bytes to 30720 bytes. The default is 64 bytes.

SLU 1: Record size plus header. (The header is 25 bytes.) The range of values that can be specified is 128 bytes to 30720 bytes. The default is 256 bytes.

NTO: The range of values that can be specified is 256 bytes to 30720 bytes. The default is 256 bytes.

Output message segments are not blocked. Each segment is sent as an RU. Segments greater than the RU size are spanned, but an RU never contains more than one segment.

SLU 2: The range of values that can be specified is 256 bytes to 30720 bytes. The default is 1500 bytes. A 3790 defined as SLUTYPE2 has a maximum value of 1536.

SLU P: Record size plus header. (The header is 5 bytes if MFS is not used and up to 42 bytes if MFS is used.) The range of values that can be specified is 64 bytes to 30720 bytes. The default is 64 bytes.

LU 6.1: Record size plus header. The range of values that can be specified is 256 bytes to 30720 bytes. The default is 256 bytes. The header size without MFS is variable from 8 bytes to 45 bytes; with MFS, the header size is variable from 8 bytes to 62 bytes.

Related reading: For more information about LU 6.1 record size, see *IMS Version 15.4 Communications and Connections*.

For all logical units that require a bind from IMS, the OUTBUF buffer size must be a decimal value that can be expressed by the algorithm $X \text{ times } 2 \text{ to the power of } Y$. X must be a value from 8 through 15 and Y must be a value from 3 through 11. This is a VTAM restriction. Thus, for example, the value 144 (representing 9×2^4) and the value 28672 (representing 14×2^{11}) are acceptable values. Details of this VTAM restriction are described in *z/OS V1R2 Communications Server: SNA Programming*, with information about requesting unit sizes.

For an IMS 15.4 system partnering with another IMS 15.4 system or an IMS Version 11 or IMS Version 10 system, any size between 1024 and 65536 is valid. For IMS 15.4 systems partnering with versions of IMS before Version 10, valid VTAM buffer sizes are restricted to one of the following decimal values:

112
120
128
144
160
176
192
208
224
240
256
288
320
352
384
416
448
480
512
576
640
704
768
768
832
896
960
1024
1152
1280
1408
1536
1664
1792
1920
2048
2304

IMS converts the value given here to the format required for the bind parameter fields and places the value into the appropriate field in the bind parameter list. If the maximum RU value specified cannot be converted exactly into the bind format, the value is rounded down to the next-lower value bind format for inbound RUs and rounded up to the next-higher value bind format for outbound RUs.

Note: For IMS to CICS ISC connections, IMS checks the ISC link buffer definitions during the bind to avoid potential storage corruption that could occur by receiving a message that is larger than the available buffer. If a mismatch is detected, IMS issues message DFS2066I.

To avoid this conflict, ensure that:

1. If CICS is the primary half session, the CICS RECEIVESIZE is greater than or equal to the IMS OUTBUF size.

2. If IMS is the primary half session, the CICS SENDSIZE is greater than or equal to the OUTBUF size.
3. VTAM buffer sizes are a valid decimal value (expressed by the algorithm $x \text{ times } 2 \text{ to the power of } y$, with $x = 8$ through 15 , and $y = 3$ through 11). If valid VTAM buffer sizes are not specified, unwanted rounding of those values might occur, and a mismatch in bind RU sizes might result.

PTRSIZE=

Specifies the number of print positions of the 3284 or 3286 printer. The default is 120.

PTRSIZE=IGNORE causes MFS to always use the device output format (DOF) with FEAT=IGNORE in its DEV statement when editing output for this device. The existing parameters and control block values, including default parameters, are unchanged.

PU=

Specifies the type of physical device that is connected by means of the Network Terminal Option (NTO) licensed program. PU= is a required keyword for NTO devices; an error message results if it is omitted.

Each keyword represents a device type.

- TTY—TTY devices, such as a 33/35, or TTY compatible devices, such as a 3101 running in TTY mode.
- LUNS—These devices are non-SNA logical units, such as a 3101 not running in TTY mode.

SEGSIZE=

Specifies the maximum size of IMS message segments that are sent to IMS. Acceptable values are from 256 bytes to 32000 bytes. The default is 256.

If an APPC logical record exceeds the SEGSIZE value, IMS breaks the record into multiple IMS segments. The IMS application must issue get Next (GN) DL/I calls to receive the second through nth segments.

Calculate the segment size as follows:

- SLU 1, SLU P, and NTO devices:

Size is the maximum input segment size that can result from blocking or deblocking one or more SCS1 input records. This parameter is ignored for non-SCS1 devices.

- LU 6.1:

Size equals the size of the largest input record that can result from blocking or deblocking one or more VLVB or chain records.

IMS spans queue buffers on an ISC input message if the data is sent in VLVB format. This allows IMS to handle large ISC input messages without having to increase the LGMSG buffer size. IMS obtains an input buffer based on SEGSIZE and fills this buffer with VLVB input data before enqueueing as a message segment. For example, if the LGMSG buffer size is 8 KB and the SEGSIZE is 8 KB, a 32-KB message received from CICS in VLVB format would be enqueueing as four 8 KB message segments spanning four 8-KB LGMSG queue buffers. The IMS application would issue a Get Unique (GU) call followed by 3 Get Next (GN) calls to get the entire message.

A DFS2056 message is issued if the input segment exceeds the value for SEGSIZE.

SESSION=

For LU 6.1 sessions, specifies the maximum number of parallel sessions for the logical unit defined in the TERMINAL macro statement. From 1 to 4095 parallel sessions can be established. The default is 1.

When defining the XRF ISC SURVEILLANCE link, set the number of parallel sessions equal to one, or eliminate the SESSION= parameter.

SIZE=

Specifies the physical screen size of this 3270 display terminal having the device type symbolic name in the TYPE= operand. MFS uses the specified screen size to verify format specification. The first and second positional parameters of the operand relate to screen lines and columns, respectively. Both numbers must be specified as decimal numbers having the following range:

```
llll = 1 through 16384
cccc = 2 through 16384
product of llll x cccc = 80 through 16384
```

where *llll* is the number of lines and *cccc* the number of columns available on the screen.

For 3270 devices defined as SLUTYPE2, the maximum number of lines and the maximum number of columns that can be defined for each is 255. Any symbolic name can be associated with any size screen. However, after this association is defined, the same device type symbolic name must be used. That is, it must duplicate a previously specified TYPE= specification of the LINEGRP, TYPE, or TERMINAL statement.

Specification of the physical screen size is required for the first (or only) definition of the specific device type symbolic name and can be omitted for subsequent identical device type symbolic name specifications. If omitted, the SIZE keyword operand originally specified with the device type symbolic name is used when the symbolic name is repeated. If the SIZE keyword is specified, the screen size defined must be the same as that defined for the original device type symbolic name specification. You should establish a standard for relating device type symbolic names to the physical screen sizes.

The standards listed in [Table 57 on page 497](#) are recommended:

Table 57. Standards to relate device names to screen sizes

User-defined symbolic name	Screen size
3270-A1 or 3270-A01	12x80
3270-A2 or 3270-A02	24x80
3270-A3 or 3270-A03	32x80
3270-A4 or 3270-A04	43x80
3270-A5 or 3270-A05	12x40
3270-A6 or 3270-A06	6x40
3270-A7 or 3270-A07	27x132
3270-A8 or 3270-A08	62x160

For the 3270 display devices defined with the device type symbolic name, the system definition produces an MFS Device Characteristics Table (DFSUDT0x) where x is the suffix specified in the SUFFIX keyword of the IMSGEN macro statement. You can also use the MFS Device Characteristics Table (DCT) utility (DFSUTB00) to build and update this table. This table is stored in IMS.SDFSRESL and is used by the MFS Language Utility and the IMS online to extract the information associated with the specific device type symbolic name.

Important: The MFS DCT must include each combination of device type symbolic name, features, and screen size for all 3270 and SLU-2 terminals that are to be connected to IMS. Because ETO terminals are not defined in the IMS system definition, if DCT entries for ETO 3270 and SLU-2 terminals are not already in the DCT as the result of system definition statements for static terminals, use the MFS DCT utility to add the entries.

If the MFS Language utility (DFSUPAA0) cannot find the correct entry in the MFS DCT, based upon device type symbolic name (3270-An) and features, then the MFS Language utility produces error message DFS1862 or DFS1863. When a user logs on to an ETO 3270 or SLU-2 terminal that is connected to IMS, and VTAM provides the screen size to IMS, IMS uses the screen size and the features that are specified on the logon descriptor to search the MFS DCT. IMS searches the MFS DCT to determine the device type symbolic name. If the search is unsuccessful, the logon attempt is rejected with messages DFS3646 and DFS3672.

Related reading:

- Refer to *IMS Version 15.4 Database Utilities* for additional information about the MFS Language utility and the MFS DCT utility.
- Refer to *IMS Version 15.4 Application Programming APIs* for more information about the Device Characteristics Table

MNOTE statements in the system definition stage 1 output listing denote each device type symbolic name specified for 3270 and SLU type 2 devices with their corresponding screen size values.

Example:

Display Device Symbolic Names and Screen Sizes

Symbolic Name	Screen size	
	Lines	Columns
3270-A01	12	80
3270-A02	24	80
3270-A03	32	80
3270-A04	43	80

After a device type symbolic name (for example, 3270-A03) is associated with a screen size (for example, 32x80), the size need not be specified and must not be changed for any TYPE or TERMINAL macro statement for which the same device type symbolic name is used. During a subsequent system definition, the MFS Device Characteristics table and terminal control blocks can change if terminal specifications are altered. You should examine your MFS formats to determine whether they are affected by the changes and recompile them if necessary.

TYPE=

Specifies that an alphanumeric symbolic name for a device type is to be associated with this IMS-supported VTAM 3270 physical display terminal. The symbolic name can be of the form 3270-*Ann*, where *nn* is a value from 01 through 15. The leading zero can be omitted. The physical screen size of the 3270 display device associated with the device type symbolic name is specified in the SIZE= operand. Any 3270 display device can be defined with a device type symbolic name. 3270 display devices having 480-character or 1920-character screen sizes can be defined using the MODEL keyword parameter rather than the TYPE and SIZE keyword parameters. However, 3270 display devices with other than 480 or 1920 characters must be defined using the device type symbolic name and, therefore, TYPE and SIZE. The TYPE/SIZE and MODEL keyword parameters are mutually exclusive.

UNIT=

Specifies the terminal for the previously defined line group. For 3270 line groups, UNIT= is used to define this terminal as a 3284 or 3286 printer or 3277 display unit. 3277 display units cannot be defined in the same local line group as 3284 or 3286 printers.

TRANSACT macro

Use the TRANSACT macro statement to specify the transaction codes that cause the application program named in the preceding APPLCTN macro to be scheduled for execution in an IMS message processing region.

The TRANSACT macro statement is used one or more times with each APPLCTN macro statement to identify transactions as IMS exclusive, IMS Fast Path potential, or IMS Fast Path exclusive. It also provides the IMS control program with information that influences the application program scheduling algorithm. It can define a message editing routine.

If you do not include this macro during stage 1 system definition, no warning is issued, and it is assumed that you define your transaction codes dynamically. You can define them dynamically using either **CREATE TRAN** and **UPDATE TRAN** commands, or the Destination Creation exit routine (DFSINSX0).



Attention: When you define programs or transactions (using the APPLCTN and TRANSACT macros) to an IMSplex using shared queues, you must ensure that the programs and transactions are defined with the same attributes on all IMS systems in the IMSplex. If the attributes are defined differently on different IMS systems in the IMSplex, results can be unpredictable. For example, a

transaction defined as conversational on one IMS and non-conversational on another IMS causes unpredictable results when messages for that transaction are put on the shared queues.

If the TRANSACT macro statement is preceded by an APPLCTN macro defining it as remote (specifies SYSID), this transaction is generated as a remote transaction.

An IMS Fast Path-exclusive transaction is identified by a TRANSACT macro statement following an APPLCTN statement that specifies both PGMTYPE=TP and FPATH=YES.

TRANSACT macro statements that identify IMS Fast Path-exclusive transactions generate routing code entries. These entries are automatically generated and have the same name as the corresponding transaction codes. They are used by the IMS Fast Path Expedited Message Handler routines to locate the Fast Path application program named in the preceding APPLCTN macro statement that processes the input message.

An IMS Fast Path-potential transaction is identified by a TRANSACT macro statement that specifies FPATH=YES following an APPLCTN statement that specifies PGMTYPE=TP and FPATH=NO.

An application defined as FPATH=NO cannot be run in a Fast Path region (IFP), even though the application contains Fast Path-potential transactions. To run these Fast Path-potential transactions in an IFP region (a region that has FPATH=YES specified on the APPLCTN macro), both of the following conditions must be true:

- A routing code must be specified for the IFP on the RTCODE macro.
- The Fast Path-potential transaction must be routed to the IFP by the appropriate routing code.

All Fast Path transactions are implicitly defined as recoverable.

MSGTYPE=(SNGLSEG,RESPONSE) must be specified on the TRANSACT statement for Fast Path potential transactions.

Additional routing codes can be associated with a Fast Path application program by using the RTCODE macro statement following the corresponding APPLCTN macro statement.

TRANSACT macro statements with FPATH=YES and RTCODE macro statements are invalid after APPLCTN macro statements that define an IMS batch message processing (BMP) application.

Dynamic definition

If you do not include this macro during stage 1 system definition, no warning is issued, and it is assumed that you define your transaction codes dynamically.

To dynamically define the transaction codes that cause previously defined application programs to be scheduled for execution, you can use:

- The **CREATE TRAN** and **UPDATE TRAN** type-2 commands.
- The Destination Creation exit routine.

It is recommended that you enable dynamic resource definition for MODBLKS resources to dynamically update existing transactions. Changes to existing transactions cannot be introduced through a MODBLKS online change if those attributes are changeable by online commands. You can use the /ASSIGN or /CHANGE commands to change existing transactions, but the command needs to be reissued after you perform a local online change or a global online change, before the affected transactions are scheduled. Dynamically updating transactions allows you to avoid issuing and then reissuing the /ASSIGN or /CHANGE commands for the existing transactions.

When DRD is disabled, **CREATE**, **DELETE**, **IMPORT**, and most **UPDATE** commands that change the definitional attributes of a resource are rejected.

The following table compares the TRANSACT macro keywords and the equivalent **CREATE** and **UPDATE** command keywords used for dynamic definition. The table also includes equivalent values for the INSXTRNQ DSECT, which is mapped to by the DFSINSX0 parameter list. The information in INSXTRNQ is used to create a transaction control block if the destination is a transaction. Default values are shown in **bold**.

Table 58. TRANSACT macro keywords and the equivalent CREATE and UPDATE command keywords used in dynamic definition

TRANSACT macro keyword	CREATE UPDATE TRAN keyword equivalent	INSXTRNQ DSECT information
Previous APPLCTN macro statement	PGM(<i>name</i>)	TRNQ_PGM
AOI=(N TRAN Y)	AOCMD(N TRAN Y)	TRNQ_F5_AOIY TRNQ_F5_AOIN TRNQ_F5_AOITRAN
CODE=transaction code	NAME(<i>name</i>)	Not applicable.
DCLWA= YES NO	DCLWA(Y N)	TRNQ_F3_DCLWAY TRNQ_F3_DCLWAN
EDIT=(UC ULC, <i>editname</i>)	EDITUC(Y N) EDITRTN(<i>name</i>)	TRNQ_F3_EDITUCY TRNQ_F3_EDITUCN TRNQ_EDITRTN
EXPTIME= (<i>seconds</i>)	EXPTIME(<i>number</i>)	TRNQ_EXPTM
FPATH=(NO YES <i>size</i>)	FP(N E P) EMHBSZ(<i>size</i>)	TRNQFP TRNQFPP TRNQ_F2_FPN TRNQ_EMHBSZ
INQUIRY=(NO YES, RECOVER NORECOV)	INQ(N Y) RECOVER(Y N)	TRNQ_F4_INQY TRNQ_F4_INQN TRNQ_F4_RECOVERY TRNQ_F4_RECOVERN
MAXRGN= 0 number	MAXRGN(0 number)	TRNQ_MAXRGN
MODE= MULT SNGL	CMTMODE(MULT SNGL)	TRNQ_F3_CMTMODEM TRNQ_F3_CMTMODES
MSGTYPE= (MULTSEG SNGLSEG, NONRESPONSE RESPONSE, 1 class)	MSGTYPE(MULTSEG SNGLSEG) RESP(N Y) CLASS(1 class)	TRNQ_MSEG TRNQ_F2_SSEG TRNQ_RESP TRNQ_F2_RESPN TRNQ_CLASS
PARLIM= 0 number	PARLIM(0 number)	TRNQ_PARLIM
PROCLIM= (65535 count, 65535 CPU-time-per-transaction) Note: For Fast Path potential transactions, IMS interprets the <i>CPU-time-per-transaction</i> value as hundredths of seconds.	PLCT(65535 value) PLCTTIME(6553500 CPU-time-per-transaction)	TRNQ_PLCT TRNQ_PLCTTIME
PRTY= (1 normal, 1 limit, 65535 limit count)	NPRI(1 value) LPRI(1 value) LCT(65535 value)	TRNQ_NPRI TRNQ_LPRI TRNQ_LCT

Table 58. TRANSACT macro keywords and the equivalent CREATE and UPDATE command keywords used in dynamic definition (continued)

TRANSACT macro keyword	CREATE UPDATE TRAN keyword equivalent	INSXTRNQ DSECT information
ROUTING= NO YES	DIRROUTE(N Y)	TRNQ_F3_DIRROUTEY TRNQ_F3_DIRROUTEN
SEGNO= 0 number	SEGNO(0 number)	TRNQ_SEGNO
SEGSIZE= 0 size	SEGSIZE(0 size)	TRNQ_SEGSZ
SERIAL= NO YES	SERIAL(N Y)	TRNQ_F4_SERIALY TRNQ_F4_SERIALN
SPA= (size, STRUNC RTRUNC)	CONV(Y) SPASZ(size) SPATRUNC(S R)	TRNQCONV TRNQ_F2_CONVN TRNQSPAL TRNQSTRU TRNQTRU
SYSID=(remote system id, local system id) (specified either in the TRANSACT macro or in the previous APPLCTN macro)	SIDL(localsysid) SIDR(remotesysid) or MSNAME(msname) REMOTE(Y)	TRNQSIDL TRNQSIDR TRNQ_F4_REMOTERY TRNQ_F4_REMOTEN
TRANSTAT= N Y	TRANSTAT(N Y)	The TRANSTAT keyword is optional. If a value is not specified for the TRANSTAT keyword, the system default is used.
WFI	WFI(N Y)	TRNQ_F5_WFIY TRNQ_F5_WFIN

Supported environments

The TRANSACT macro can be optionally used in IMS DB/DC and DCCTL environments.

Syntax

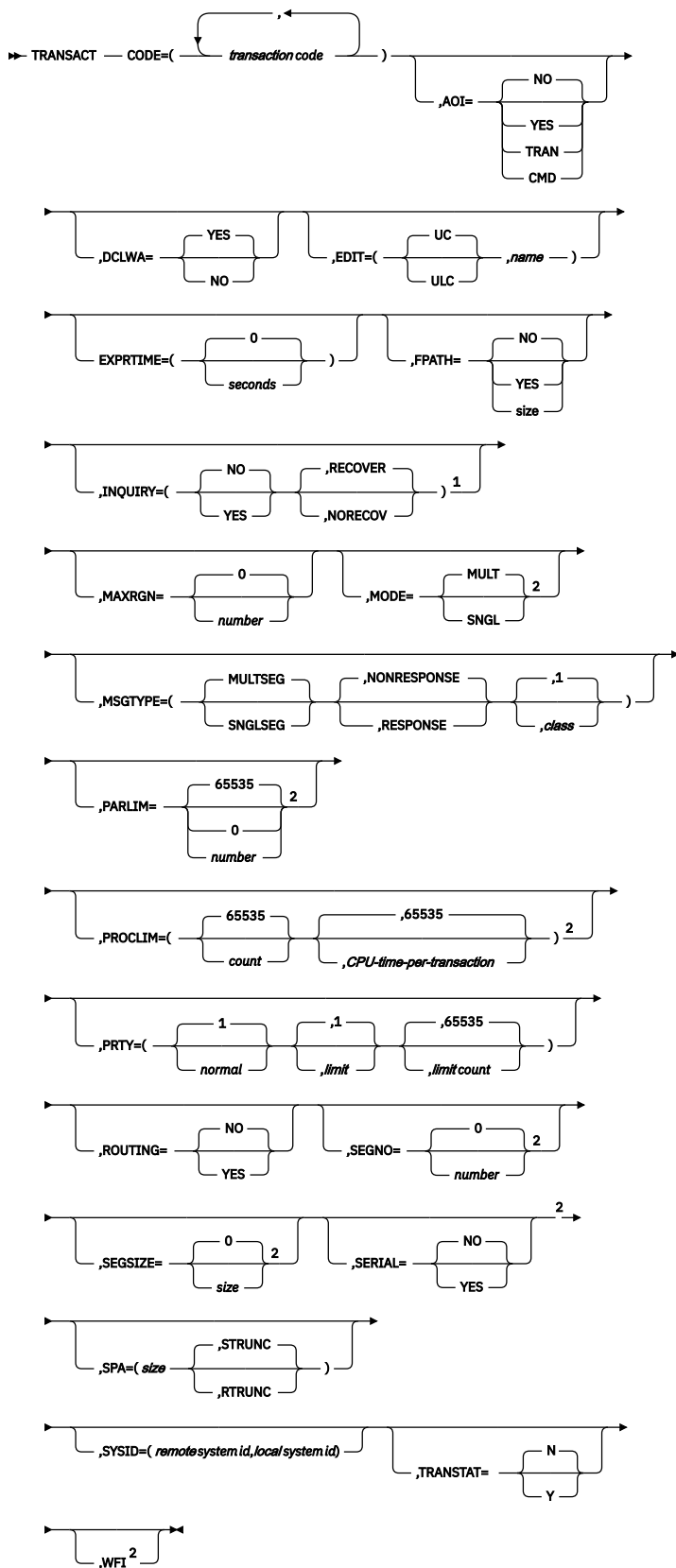

Notes:

¹ NORECOV is not valid when NO is specified.

² These operands are not appropriate if a transaction destined for processing in another (remote) system is being specified.

Positional parameters

WFI is the only positional parameter for the TRANSACT macro.

Keyword Parameters

To find which parameters apply to your IMS configuration, refer to [“Selecting the appropriate macros to define your system”](#) on page 5.

AOI=

For type-1 AOI: For Type 1 Automated Operator Interface (AOI), specifies whether (YES | TRAN | CMD) or not (NO) a particular transaction is allowed to issue the AOI command (CMD) call.

NO

When AOI=NO, a particular transaction cannot issue the AOI command (CMD) call. If the EXEC parameter AOI1=N is defined, all transactions are allowed to issue the CMD call, including this transaction. AOI1=N overrides AOI=N.

YES

When AOI=YES is specified, the authorization of the commands is like authorization for ICMD calls; the user ID or program name is used for authorization. For some environments, if a Get Unique call has not yet happened, then the program name is used for the authorization. Specifying AOI=YES requests that the user ID of the user who entered the transaction be authorized against the command (in CIMS class).

TRAN

The TRAN specification is the same as YES, but it also requests that IMS use the transaction code, instead of the user ID of the user who entered the transaction, to check the authorization of the commands for the CMD calls issued by the transaction.

When a transaction is defined with AOI=TRAN, the first authorization check done for AOI for the transaction results in the accessor environment element (ACEE) being built. This environment is kept for use by future authorization checks. In this case, the type-1 AOI transactions need to be defined to RACF (or equivalent product) as a user. The transactions are then specified on RACF PERMIT statements for each command they are allowed to issue from a type-1 AOI transaction. Specifying AOI transactions as users to RACF might conflict with the name of a user already defined to RACF. If this occurs, then either the transaction name or the existing user name needs to be changed.

CMD

The CMD specification is the same as YES, but also indicates that authorization checking is based on which transactions can issue a particular command. In this case, the commands (or the first three characters of the commands) need to be defined to RACF (or equivalent product) as a user. The type-1 AOI transactions must be defined as profiles under the TIMS class, and for each transaction, the commands it can issue must be specified. Using the CMD specification requires you to create fewer user IDs than you need to create for the AOI=TRAN specification. However, using the CMD specification requires you to create or modify a larger number of resource profiles.

Note: If you specify AOI=YES, AOI=TRAN, or AOI=CMD for a transaction and the message being returned on the GU call was received by IMS before the start of IMS execution, a CF status code results. If your application has not specified CF as an acceptable status code, an abend results.

The following table describes how the AOI= specification on the TRANSACT macro impacts the specifications on the EXEC parameter AOI1=.

Table 59. Relationship between AOI= and AOI1= specifications

EXEC parameter AOI1= specification	Effect on TRANSACT macro AOI= specifications
R C A	All specifications are retained.
N	NO specification is set to YES. YES specification is retained. TRAN and CMD specifications are reset.

For type-2 AOI: The AOI parameter is also available for type-2 AOI security. However, AOI=NO applies only to type-1 AOI. If AOI=NO is specified or set by default, RACF is used for security checking.

If the TRAN specification is used for type-2 AOI, IMS uses the transaction code, instead of the user ID of the user who entered the transaction, to check the authorization of the commands for the ICMD calls issued by the transaction.

If the CMD specification is used for type-2 AOI, authorization checking is based on which transactions can issue a particular command.

For IMS environments that do not support the use of a transaction, such as a non-message-driven BMP, the AOI=TRAN | CMD specification is not available, and the security checking that is performed is like the checking performed when only YES is specified.

CODE=

Specifies one or more one- to eight-character alphanumeric transaction codes or remote transaction codes. If more than one code is specified, each transaction code name is assumed to have the same characteristics as all other keyword or positional parameter specifications or defaults. Enclose multiple names in parentheses and separate them with commas. Each character of transaction codes and logical terminal names must be an alphanumeric character (A through Z, #, \$, @, or 0 through 9). Transaction codes, logical terminals on the NAME macro, and linknames on MSNAME macros must comprise a set of values, each of which is unique in the system. That is, transaction codes, logical terminal names, and MSC linknames, collectively, cannot contain duplicates. The CODE operand is required.

Example:

```
CODE=(TRAN1,TRAN2,TRAN3)
```

DCLWA=

Specifies whether (YES) or not (NO) IMS should perform log write-ahead for recoverable, nonresponse mode input messages and transaction output messages. If not specified in the TRANSACT macro, the default is the DCLWA parameter in the IMSCTRL macro. The DCLWA parameter in the TRANSACT macro overrides the IMSCTRL macro parameter for this transaction.

Specify or accept a default of YES to ensure that both of the following occur:

- A nonresponse input transaction is made recoverable across IMS failures, before IMS acknowledging receipt of the input.
- Database changes are made recoverable before IMS sending associated output reply messages.

YES ensures that information in the log buffers is written to the IMS log, before the associated input acknowledgment or output reply is sent to the terminal.

Specify or accept a default of YES for all VTAM terminal types.

Specify NO if input message integrity and the consistency of output messages with associated database updates is not required. DCLWA does not apply to response mode or Fast Path input processing, and is ignored during IMS execution.

EDIT=

Specifies whether (UC) or not (ULC) the input data is to be translated to uppercase. The first parameter of this operand defines whether the transaction is uppercase/lowercase (ULC) as entered

from the terminal, or if it is to be translated to uppercase (UC) before being presented to the processing program. The default is UC.

Specifying UC for VTAM terminals prevents the transmission of embedded device control characters.

You can also use EDIT to specify the 1- to 8-character name of your own transaction input edit routine that edits messages before the program receiving the message. This name must begin with an alphabetic character. The specified edit routine (load module) must reside in an authorized library in the JOBLIB, STEPLIB, or LINKLIST library concatenated in front of the IMS.SDFSRESL. This routine cannot be the same as the one that is used on a LINEGRP or TYPE EDIT= parameter.

If FPATH=YES is specified, the EDIT= keyword parameter specifies whether (UC) or not (ULC) the transaction is to be translated to uppercase before being presented to the edit/routing exit routine. Specification of a user edit routine is valid on a Fast Path potential transaction; this specification is used when the transaction is routed to IMS. It is invalid on a Fast Path exclusive transaction.

For input from LU 6.2 devices, the LU 6.2 Edit exit routine (DFSLUEE0) is called instead of the transaction input edit routine specified in EDIT.

For input from OTMA devices, the OTMA Input/Output Edit user exit (OTMAIOED) is called instead of the transaction input edit routine specified in EDIT.

EXPRTIME=

The length of elapsed time, in seconds, that IMS can use to cancel the input transaction. For transactions that exceed the specified elapsed time, IMS identifies the input transaction as expired and discards the transaction. The value can range from 0 to 65535. The default is 0, meaning that no expiration is set for this transaction. If an invalid value is specified, message G316 is issued.

Restriction: The transaction expiration checking is not performed at the GU time for Fast Path transactions, IMS conversational transactions, program-to-program switch transactions, and APPC synchronous transactions.

FPATH=

Specifies whether (YES, size) or not (NO) the transaction code is a potential candidate for Fast Path processing. FPATH=YES is effective only when specified on a TRANSACT statement that follows an APPLCTN statement that does not specify FPATH=YES; otherwise, the operand is ignored. FPATH=size, which determines the EMH buffer size required to run the transaction, overrides the EMHL execution parameter and implies FPATH=YES. The minimum specification for FPATH=size is 12; the maximum is 30720. The default is FPATH=NO.

Fast Path-potential transactions must be processed by a user edit/routing exit to determine whether the transaction is to be processed by IMS Fast Path. If it is to be processed by IMS Fast Path, the edit/routing exit routine associates the transaction with a routing code. This routing code identifies which Fast Path application program is to process the transaction.

If FPATH=YES is specified during a MODBLKS system definition, Fast Path must have been previously defined for the online system.

INQ= or INQUIRY=

Specifies whether (YES) or not (NO) this is an inquiry transaction. The default is NO. You can specify this keyword either as INQ= or INQUIRY=. If INQ= (or INQUIRY=) YES is specified, you can also specify whether (RECOVER) or not (NORECOV) this transaction should be recovered during an IMS emergency or normal restart. The specification of INQ=(NO,NORECOV) is invalid. The default is RECOVER.

For IMS Fast Path transactions, RECOVER must be specified.

INQ=YES should be specified only for those transactions that, when entered, do not cause a change in any database. Programs are prohibited from issuing ISRT, DLET, or REPL calls to a database when scheduled to process a transaction defined as INQ=YES. An application program cannot do an SQL INSERT, DELETE, or UPDATE when the IMS transaction is defined with INQ=YES. The INQ operands are not position dependent.

If the SPA parameter is specified (indicating that the transaction is conversational), INQ=(YES,NORECOV) cannot be specified.

If an attempt is made to enter a transaction that is not specified as INQ=YES from one of these terminals, the transaction is rejected. A message indicating that the update transaction cannot be processed is sent to the terminal that entered the transaction.

MAXRGN=

Limits the number of message processing program (MPP) regions that can be concurrently scheduled to process a transaction. When the number of MPP regions is not limited, one transaction might monopolize all available regions.

If you specify zero, or if zero is defaulted to, no limit is imposed. The maximum number you can specify is 255.

If you specify SERIAL=YES in the TRANSACT macro or SCHDTYP=SERIAL in the APPLCTN macro, omit the MAXRGN parameter or set it equal to 0. Also, omit the PARLIM parameter in the TRANSACT macro and accept the default (65 535).

For non-zero values, you cannot specify MAXRGN= unless you also specify PARLIM=.

The value associated with MAXRGN= can be changed using a **/CHANGE TRAN** command; therefore, it is not affected by an online change sequence of operator commands for an existing transaction, whether it is altered during a MODBLKS system definition or not.

MODE=

Specifies that database buffers are to be written to direct access (flushed) upon each request for a new message (SNGL) by the processing program, or upon program termination (MULT). The default is MULT. Conversational and WFI transactions must be defined as SNGL. SNGL is forced for WFI applications.

This operand affects emergency restart. When MODE=SNGL, emergency restart only reprocesses the last completed message, regardless of whether one or more messages are scheduled and processed by a single load of an application program. Otherwise, emergency restart reprocesses those messages that were scheduled and processed by the single load of an application program, since the time of the previous checkpoint. The number of messages processed depends upon when the last checkpoint is issued.

The MODE= keyword parameters are checked on all IMS Fast Path-potential transactions for MODE=SNGL. If not specified, a warning diagnostic is issued.

If the transaction results in the application calling an external subsystem, such as DB2, the Commit Verify exit provided by the external subsystem can determine whether MODE=MULT is supported.

MSGTYPE=

Specifies the type of transaction code (single or multiple segment), and whether the communication line from which the transaction is entered is to be held until a response is received. The MSGTYPE operands are not position dependent.

The transaction code can be single segment (SNGLSEG), or multiple segment (MULTSEG). It specifies the time at which an incoming message is considered complete and available to be routed to an application program for subsequent processing. The defaults are (MULTSEG,NONRESPONSE,1).

If MSC-directed routing is used in a multiple IMS system configuration, IMS does not ensure that both the message and the transaction destined to process that message are either single segment or multiple segments.

The MSGTYPE= keyword parameters are checked on all IMS Fast Path-potential transactions for MSGTYPE=(SNGLSEG,RESPONSE). If not specified, a warning diagnostic is issued.

The first parameter of the MSGTYPE keyword specifies one of the following choices for number of segments:

MULTSEG

Specifies that the incoming message can be more than one segment in length. It is not eligible for scheduling to an application program until an end-of-message indication is received, or a complete message is created by MFS.

SNGLSEG

Specifies that the incoming message is one segment in length. It becomes eligible for scheduling when the terminal operator indicates end-of-segment.

The second parameter of the MSGTYPE keyword specifies one of the following response choices:

NONRESPONSE

Specifies that, for terminals specifying or accepting a default of OPTIONS=TRANRESP, input should not stop after this transaction is entered.

RESPONSE

Specifies that, for terminals specifying or accepting a default of OPTIONS=TRANRESP, no additional messages are to be allowed after this transaction is entered until this transaction sends a response message back to the terminal. Response mode can be forced or negated by individual terminal definition.

The third parameter of the MSGTYPE= keyword specifies the class to which this transaction code is to be assigned. This parameter must be a decimal number from 1 to 999. The default is 1.

Because the values associated with the class keyword can be changed using an **/ASSIGN** command, they are not affected by an online change sequence of **/MODIFY** operator commands for an existing transaction, regardless of whether these values are altered during a MODBLKS system definition. The value specified must not exceed the MAXCLAS= value specified or accepted by default on the IMSCTRL macro statement. Regardless of specification made or default taken, remote transaction codes are assigned a class of zero. If the transaction code class is specified in the APPLCTN macro, this parameter need not be specified. If the transaction code class is specified in both the APPLCTN and TRANSACT macros, the APPLCTN macro specification is ignored for this transaction. Define CPI transactions with a different message class from that used for non-CPI transactions. IMS handles all CPI transactions as priority zero within the transaction class.

MSGTYPE=RESPONSE is ignored during online processing for all terminals that do not operate in response mode.

PARLIM=

Specifies the threshold value to be used when SCHDTYP=PARALLEL is specified in the preceding APPLCTN macro instruction. In a non-shared queues environment, if the current transaction enqueue count exceeds the PARLIM value multiplied by the number of regions currently scheduled for this transaction, an additional region is scheduled when a subsequent schedule event for this transaction's class occurs. In a shared-queues environment, the successful consecutive GU count is used instead of the enqueue count. When the consecutive GU count equals the PARMLIM value multiplied by the number of regions currently scheduled (or when PARMLIM=0), an additional region is scheduled. Events can include the following:

- Message enqueue from terminal.
- Message insert from application. One region is allowed per sync point, EXPRESS=NO PCB. For example, when an application inserts two messages for the same transaction code, only one region is scheduled at sync point.
- **/ASSIGN** command.
- Application term thread.
- Successful application message GU (shared queues only)

If you do not specify a value for PARLIM, IMS:

- Assigns a value of 65 535 to PARLIM. You cannot specify 65 535 as a value for PARLIM.
- Allows the transaction to be scheduled in only one region at a time (that is, IMS disables transaction load balancing).

Valid values for PARLIM can be either any number from 0 to 32 767, or 65 535.

PARLIM=0 indicates that any input message (or successful GU, for shared queues) can cause a new region to be scheduled because the scheduling condition is always met (the number of messages is greater than zero).

The value specified for PARLIM applies to message processing programs (MPPs) only. PARLIM is not supported for batch message processing programs (BMPs).

PARLIM is not applicable to FPE transactions and should be allowed to default to 65 535. If a PARLIM value is specified for FPE transactions, it is ignored by scheduling. Specifying a PARLIM value other than the default value results in a branch and link (BAL) status shown for an FPE transaction on commands such as **/DISPLAY TRAN** or **QUERY TRAN**. The PARLIM and BAL status can be ignored for FPE transactions.

The value for PARLIM is not affected by an online change sequence of operator commands for an existing transaction, regardless of whether it is altered during a MODBLKS system definition because the value associated with the PARLIM= keyword can be changed using an **/ASSIGN** command.

Note: In a shared-queues environment, the PARLIM value behaves differently than it does in a non-shared-queues environment. In a non-shared-queues environment, the queue depth (the number of messages that are currently enqueued) for the transaction is used as the value that is compared with the PARLIM value to determine when to schedule another region. IMS responds to a growing queue of input transactions by scheduling more regions as the queue grows.

In a shared-queues environment, each individual IMS does not know the depth of the queue, because the queue is in the shared-queues coupling facility structure that is managed by Common Queue Server (CQS). The transaction queue might be added to by many different IMS systems. IMS is notified only when the first message is put in a queue (that is, when the queue becomes *not empty*). IMS is not notified for every subsequent message that is placed on the queue after that first message. In a shared-queues environment, the PARLIM comparison is done against a counter that each IMS keeps of the number of successful consecutive GU calls for the transaction by that IMS, rather than queue depth. IMS schedules more regions when it consistently gets messages from CQS when it asks for them. Thus, in a shared-queues environment, IMS infers the depth of the queue of messages based on processing activity, but it does not know the actual depth of the queue.

A PARLIM value of 0 in a shared-queues environment is the most responsive setting. PARLIM(0) ensures that message regions are scheduled until all messages are processed from the transaction queue, or until the maximum region value (MAXRGN) limit is reached. PARLIM(0) might, however, result in many unnecessary schedules (or *false schedules*). A false schedule occurs when a message region is scheduled and finds no more messages on the queue. This occurs particularly with PARLIM(0) because after each successful get unique (GU), IMS must always schedule an additional region to try to read the queue to see if there are more messages. This process continues for each successful GU until the queue becomes empty, at which time the successive GU count is reset to 0. This is a consequence of IMS not knowing how many messages are queued on the transaction queue.

Setting the PARLIM to a value greater than 0 can reduce the number of false schedules, because IMS then schedules a new message region only after a number of messages have been obtained consecutively without the queue becoming empty. Setting the PARLIM to a value of 2 or greater is useful for reducing false schedules for transactions that are low-volume and that run relatively quickly (such that the queue depth is typically 1), because it avoids scheduling a second region until the first region has obtained at least two messages in a row. However, be aware that while a PARLIM value greater than 0 can reduce unnecessary schedules, it is also less responsive. If a transaction is long running, or if its processing is delayed (for example, because of locking contention), the consecutive GU count does not change while the transaction is executing, and no additional message regions are scheduled. This can result in delayed processing of other messages for this same transaction until a currently-scheduled message completes. This delay can occur even if message regions are available to process the transaction.

Recommendations:

- If you specify PARLIM=0, specify a MAXRGN value to limit the number of regions that can be scheduled to process a particular transaction. If you specify PARLIM=0 and you do not specify a value for MAXRGN, one transaction might monopolize all the available regions.
- If you specify SERIAL=YES in the TRANSACT macro or SCHDTYP=SERIAL in the APPLCTN macro, omit the PARLIM parameter and accept the default (65 535). Also, omit the MAXRGN parameter in the TRANSACT macro or set it equal to 0.

PROCLIM=

Specifies the number of messages (count) of this transaction code a program can process in a single scheduling, and the amount of time (for non-Fast-Path transactions, in seconds; for Fast Path transactions, in hundredths of seconds) allowable to process a single transaction (or message). Batch Message Programs (BMPs) are not affected by these settings.

The first parameter, *count*, can be changed using an **/ASSIGN** command. Therefore, its value is not affected by an online change sequence of operator commands for an existing transaction, regardless of whether it was altered during a MODBLKS system definition.

The *count* specifies the maximum number of messages sent to the application program by the IMS control program for processing without reloading the application program. The *count* value can range from 0 through 65 535. If 0 is coded, the maximum number of messages sent to the application is one and the application program is reloaded before receiving a subsequent message. Code the *count* value at 65 535 if no limit is to be placed upon the number of messages processed at a single program load. Values 1 through 65 535 are eligible for quick reschedule processing.

The *CPU-time-per-transaction* parameter specifies the processing limit count time. This is the amount of time (for non-Fast-Path transactions, in seconds; for Fast Path transactions, in hundredths of seconds) allowable to process a all messages for a given transaction during a single schedule. The number specifies the maximum CPU time allowed for each message to be processed in the message processing region. The value is a number that can range from 1 to 65 535. Specifying the maximum value means that no time limit is placed on the application program.

For Fast Path transactions (both potential and exclusive), *CPU-time-per-transaction* represents real time that elapses during transaction processing (not accumulated task time). Real time is used because the input terminal is in response mode and cannot enter another transaction until the response is sent. The *count* subparameter is ignored.

The defaults for PROCLIM are 65 535 and 65 535.

The *count* value assigned is used to determine how many messages an application program is allowed to process in a single scheduling cycle. When the application program requests, and receives, the number of messages indicated in the *count* value, any subsequent requests result in one of two things.

1. IMS indicates "no more messages exist" if any of the following conditions are true:

- The region is not an MPP.
- The currently scheduled mode is not MODE=SNGL.
- Equal or higher— priority transactions are enqueued for the region.

IMS might, in fact, have other messages enqueued for the application program. It is the responsibility of the application program to terminate when it receives an indicator that no more messages are available. Termination of the application program makes the region it occupied available for rescheduling. This feature makes it possible for IMS to allow scheduling of higher-priority transactions that entered the system while the previous transactions were in process. In addition, if any equal-priority transactions are enqueued, they become eligible for scheduling on a first-in, first-out (FIFO) basis.

2. The region goes through quick reschedule and returns the next message to the application if all the following conditions are true:

- The region is an MPP.
- The transaction is MODE=SNGL.
- No higher priority transactions are enqueued.

- Messages are still enqueued for the application.

If equal priority transactions are enqueued, IMS allows the transaction to quick reschedule if the PROCLIM value has not been reached. If the PROCLIM value has been reached, IMS disallows the quick reschedule and processes the other transactions.

Quick rescheduling is also affected by the IMS scheduling algorithm, which takes into account the following factors and more:

- MAXRGN value
- PARLIM value
- Current number of regions in which the transaction is scheduled

The *CPU-time-per-transaction* value controls application program looping. You are not required to optimize the *CPU-time-per-transaction* value for program-transaction execution time. However, the *CPU-time-per-transaction* time value assigned should not be less than the expected per-transaction execution time. If the scheduled application program exceeds the product of *CPU-time-per-transaction* and *count*, the application program abends (if the product of *CPU-time-per-transaction* and *count* exceeds 24 hours, 24 hours is used). If an IMS STIMER value of 2 is specified on the DFSMPR macro, the region does not abend until completion of the DL/I call.

Note:

The application must not use z/OS timer services, such as STIMER TASK, that override the IMS STIMER. IMS uses the IMS STIMER to time the execution of transactions. If a z/OS TIMER is issued, it disables the IMS STIMER.

A STIMER is set for the total time to process *all* messages during the schedule. For example:

- Transaction TRAN1 will process 2 messages and each message should take about 1 second based on a PROCLIM=(2,1) setting on the transact macro.
- A STIMER set for 2 seconds (2 messages, 1 second each). If Msg1 takes 1.5 seconds, and Msg2 takes .4 seconds there should not be a U240 since only a total of 1.9 seconds has expired, even though the first message takes longer than the 1 second predicted.

The IMS STIMER task tracks processor time statistics, including time durations for:

- Application program execution time
- DL/I processing time
- CPU time for ESAF users such as Db2 for z/OS that continue to process under the TCB of the dependent region. If Db2 for z/OS switches to another TCB, which is the case with parallelism, logging, and prefetch, this time is not included.

PRTY=

Specifies the values that determine the scheduling priority of this transaction. This priority also controls the priority of messages created by this transaction and sent to a destination in a remote system.

normal

The priority assigned to this transaction when the number of input transactions enqueued and waiting to be processed is less than the *limit count* value. The valid specification range is from 0 through 14. The default is 1.

limit

The priority to which this transaction is raised when the number of input transactions enqueued and waiting to be processed is equal to or greater than the *limit count* value. The valid specification range is from 0 through 14. The default is 1.

limit count

The number that, when compared to the number of input transactions queued and waiting to be processed, determines whether the *normal* or *limit* priority value is assigned to this transaction. The *limit count* value can range from 1 through 65 535. The default is 65 535.

When the limit priority is used, and the priority is raised to the specified limit priority value, the priority is not reduced to the normal priority until all messages enqueued for this transaction code are processed.

If you do not want the limit priority for this transaction, code equal values for the normal and limit priorities, and a limit count of 65 535.

When a transaction is processed exclusively by a batch message program (BMP), code the normal and limit priorities as 0. The limit count value is ignored for a transaction processed by a BMP.

The APPLCTN macro statement forces the scheduling priority of all transaction codes associated with it to 0 if the program type is batch (PGMTYPE=BATCH on APPLCTN macro statement). However, a batch message processing region (BMP) can process transactions with scheduling priorities other than 0.

For remote transactions, the PRTY parameter determines the priority used to send the transaction to the processing system, which is termed the *MSC link message priority*. The three MSC link message priority groups are:

- Low
- Medium
- High

The low priority group consists of primary requests in the input terminal system. This group is assigned remote transaction priorities from 0 to 6. The medium group consists of secondary requests, responses, primary requests in an intermediate system, and primary requests in the input terminal system. This group is assigned a remote transaction priority of 7. The high group consists of primary requests in the input terminal system. Messages in this group are assigned remote transaction priorities from 8 to 14. Within each group, messages have a priority based on the current priority value of the transaction or remote transaction in the input terminal system for primary requests, and on the latest processing system for secondary requests and responses.

In an MSC configuration, the transaction priority determines the priority used to send messages inserted by this transaction across an MSC link. If the transaction inserts multiple messages to the same destination (for example, pages to a printer) and these messages must be sent in the order inserted, the normal and limit priority values should be the same. If the normal and limit priority values are not identical, messages inserted at a higher priority than previously inserted messages could arrive at their destination first. (This restriction does not apply to multiple segments of the same message.)

A transaction must have the same characteristics in all systems where it is defined. These characteristics include:

- Non-conversational/conversational
- SPA size if conversational
- Single-/multi-segment messages
- Non-inquiry/inquiry
- Recoverable/nonrecoverable

ROUTING=

If MSC directed routing is used in a multiple IMS system configuration, specifies whether (YES) or not (NO) the application program processing a transaction is informed of the system which originated the transaction.

If ROUTING=YES, an MSNAME corresponding to a logical path back to the originating system is placed in the I/O PCB. If ROUTING=NO, the name of the originating LTERM is placed in the I/O PCB. The default is NO.

SEGNO=

Specifies the maximum number of application program output segments that are allowed into the message queues per Get Unique (GU) call from the application program. It must be specified as a

decimal number from 0 through 65 535. The default is 0. If the default specification of 0 is used, the number of segments is not checked by the online system at execution time.

Because the value associated with the SEGNO= keyword can be changed using an **/ASSIGN** command, it is not affected by an online change sequence of operator commands for an existing transaction, regardless of whether it is altered during a MODBLKS system definition.

SEGSIZE=

Specifies the maximum number of bytes allowed in any one output segment. It must be specified as a decimal number from 0 through 65 535. The default is 0. If the default specification of 0 is used, the segment size is not checked by the online system at execution time.

Because the value associated with the SEGSIZE= keyword can be changed using an **/ASSIGN** command, it is not affected by an online change sequence of operator commands for an existing transaction, regardless of whether it is altered during a MODBLKS system definition.

The maximum output message segment to a LU 6.2 device is 32,767. If a transaction is expected to send output to a LU 6.2 device, the SEGSIZE parameter should be no greater than 32,767. However, this is not enforced during processing of the TRANSACT macro, because IMS cannot determine the device type for the message destination until output time.

SERIAL=

Forces serial processing of messages for a given transaction. When SERIAL=YES, U3303 pseudoabends do not cause the message to be placed on the suspend queue but rather on the front of the transaction message queue, and the transaction is stopped with a USTOP.

The USTOP of the transaction is removed when the transaction or the class is started with a **/START** command.

The default for this keyword is NO, which means message processing is done as before with the messages placed on the suspend queue after a U3303 pseudoabend. Scheduling continues until repeated failures result in the transaction being stopped with a USTOP.

If you specify SERIAL=YES, omit the MAXRGN parameter in the TRANSACT macro or set it equal to 0. Also, omit the PARLIM parameter in the TRANSACT macro and accept the default (65 535).

SPA=

Defines, by inclusion, that this transaction is a conversational transaction.

size

Specifies the size of the conversational scratchpad area (SPA). The size specified must be between 16 bytes and 32767 bytes inclusive.

STRUNC | RTRUNC

You can turn on the truncated data option (STRUNC) or off (RTRUNC).

If you specify SPA=STRUNC, IMS preserves all the data in the SPA, even when a program switch is made to a transaction that is defined with a smaller SPA. The transaction with the smaller SPA does not see the truncated data, but when the transaction switches to a transaction with a larger SPA, the truncated data is used.

If you specify SPA=RTRUNC, the truncated data is not preserved.

STRUNC is the default.

When a conversation initially starts, and when a program switches, the STRUNC | RTRUNC option is checked and set or reset as specified. When the option is set, it remains set for the life of the conversation, or until a program switch occurs to a transaction that specifies the option is to be reset.

When a program switch occurs, the truncated data option for the new transaction is first checked, and if specified (either STRUNC or RTRUNC), that specification is set for the conversation and is used for the SPA inserted into the output message. If the option is not specified for the new transaction, the option currently in effect for the conversation is used.

Restriction: The CORE, DASD, and FIXED operands can no longer be used. If you specify them, assembly errors occur.

SYSID=

In the multiple-IMS system configuration, specifies the system identification (SYSID) of the remote system (the system on which the application executes) and the SYSID of the local system (the originating system to which the responses are returned). The values specified must be from 1 through 2036. The remote SYSID specified must also be defined in an MSNAME macro statement, but the local SYSID can be defined in any or all the MSNAME, TRANSACT, and APPLCTN macro statements.

If the SYSID parameter is specified in the APPLCTN macro statement, you need not specify the SYSID in the TRANSACT macro statement. If the SYSID is specified in both the APPLCTN and the TRANSACT macro statements, the TRANSACT specification is ignored.

The SYSID parameter is independent of the link type (CTC, MTM, VTAM) specified on the TYPE= keyword of the MSPLINK macro statement. Because the values associated with the SYSID= keyword can be changed using an **/MSASSIGN** command, they are not affected by an online change sequence of operator commands, regardless of whether the values are altered during a MODBLKS system definition. The values only take effect during an IMS cold start.

A Fast Path-exclusive transaction cannot have SYSID= specified. To assign a remote transaction as local, the associated APPLCTN macro must be defined as local. This means that no SYSID= parameter can be specified for the associated APPLCTN macro.

Restriction: A MODBLKS online change is rejected if you attempt to add the SYSID parameter when a change to any other parameter specified on the TRANSACT macro is also requested.

TRANSTAT=

Specifies whether transaction level statistics are logged. If you specify Y, transaction-level statistics are written to the log in an X'56FA' log record.

N

Transaction-level statistics are not logged.

Y

Transaction-level statistics are logged.

The TRANSTAT keyword is optional. If a value is not specified for the TRANSTAT keyword, and the default descriptor is the IMS-defined descriptor DFSDSTR1, the value in the DFSDFxxx PROCLIB member TRANSTAT parameter that was set at IMS cold start is used. Changing the DFSDFxxx TRANSTAT value across a restart does not affect the default descriptor TRANSTAT value. Use the TRANSTAT keyword on the **CREATE TRAN** or **CREATE TRANDESC** command to override the system default when creating a transaction or transaction descriptor.

WFI=

The positional parameter WFI specifies that this is a wait-for-input transaction. A message processing or batch processing application program that processes WFI transactions is scheduled and invoked normally. If the transaction to be processed is defined as WFI, the program is allowed to remain in main storage after it has processed the available input messages. The QC status code (no more messages) is returned to the program if any of the following are true:

- The PROCLIM *count* is reached.
- A command is entered to change the status of the scheduled transaction, database, program, or class.
- The **/DBR**, **/DBD**, or **/STA** commands that relate to the databases used by the transaction are entered.
- IMS is terminated with a checkpoint shutdown.

MODE=SNGL is forced when WFI is specified.

Related concepts

[Conversational structure \(Application Programming\)](#)

Related reference

[Commit Verify exit routine \(Exit Routines\)](#)

TYPE macro

The TYPE macro statement defines the beginning of a set of macro statements for communication terminals and logical terminals, including the macros TERMINAL and NAME.

TYPE defines terminals attached to IMS through VTAM. It is equivalent to the LINEGRP/LINE macro set used to define terminals attached to IMS by means other than VTAM.

In addition to the keyword parameters described in this topic, any keyword parameter of the TERMINAL macro statement except EDIT, LTERM, NAME, COMPT, and COMPT1 through COMPT4 can be specified as a keyword operand of the TYPE macro statement. Any specified keyword value provides default values for subsequent TERMINAL macro statements within this terminal description set.

Dynamic definition

You cannot dynamically define the beginning of a set of communication terminals and logical terminal description macro statements.

Supported environments

The TYPE macro can be used in the DB/DC and DCCTL environments.

Syntax

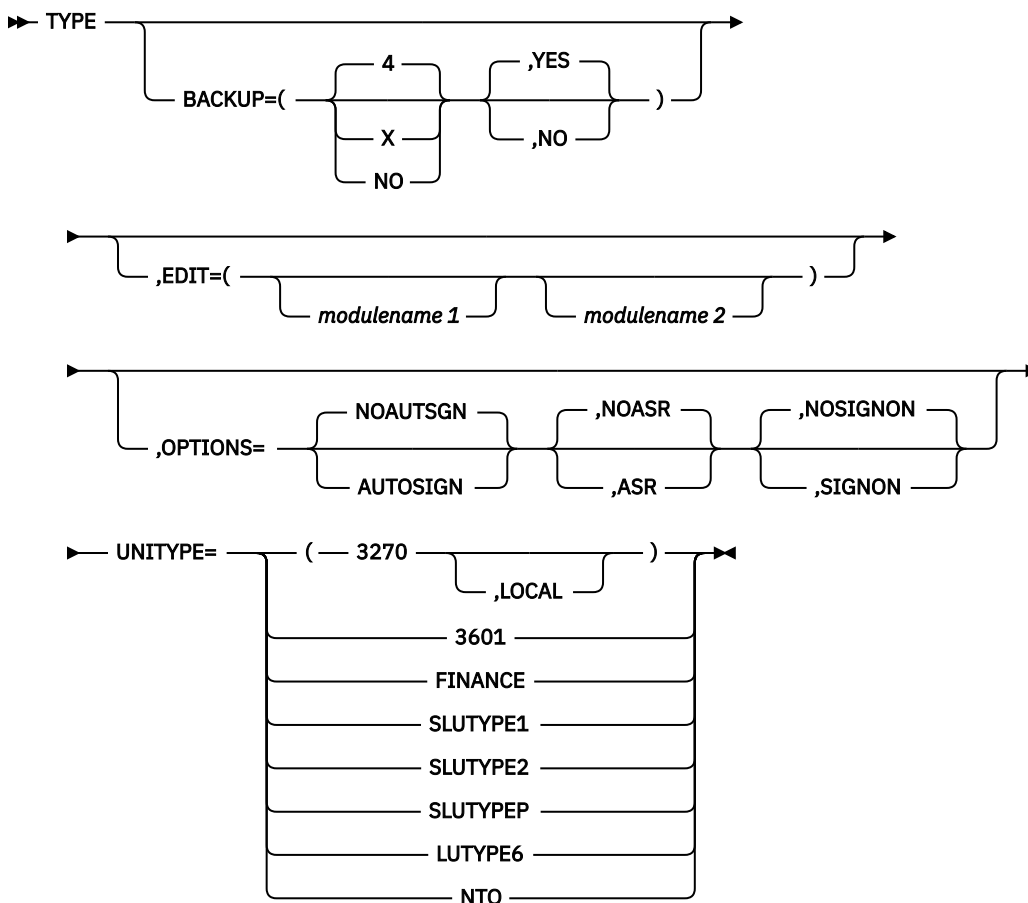

Positional parameters

The TYPE macro does not include positional parameters.

Keyword parameters

To find which parameters apply to your IMS configuration, refer to [“Selecting the appropriate macros to define your system” on page 5](#).

BACKUP=

Specifies (for XRF only) the control of session switching (VTAM) after takeover. Use only when HSB=YES is specified on the IMSCTRL macro.

X is a numeric integer from 1 to 7, inclusive, that specifies priority for reestablishing the session. The default is 4 when either keyword or parameter is omitted. NO suppresses session recovery of the terminal at takeover.

Although IMS sets priorities for VTAM requests, the active requests can be completed in any order because of internal VTAM conflicts and pacing.

The second parameter determines whether the backup system is to attempt to establish a backup session to the terminal when the active request establishes a session. When the entire keyword or this parameter is omitted, the default is YES. Specifying NO suppresses the establishment of a backup session.

EDIT=

modulename 1 specifies the 1- to 8-byte name of a user-supplied physical terminal output edit routine for the terminals in this communication description set.

modulename 2 specifies the 1- to 8-byte name of a user-supplied physical terminal input edit routine for the terminals in this communication description set.

This routine cannot be the same as the one that is used on a TRANSACT EDIT= parameter.

OPTIONS=

- Specifies (for the Session Outage Notification facility only) automatic session restart (ASR) processing on all nodes of the same type. The default is NOASR.

The ASR and NOASR definitions on the TERMINAL macro override those definitions on the TYPE macro. However, the ASR option is not supported for nodes that can have XRF backup sessions.

Use the /DIS command to display the current ASR option, and the /CHANGE command to change it.

- Specifies signon verification security processing (SIGNON). The default is NOSIGNON.

The SIGNON and NOSIGNON definitions on the TERMINAL macro override those definitions on the TYPE macro.

Instead of specifying OPTIONS=SIGNON in more than one system definition macro, you can require all static terminals to sign on by specifying a single parameter, SIGNON=ALL, in the DFSDCxxx PROCLIB member.

Related Reading: For more information about the SIGNON keyword, see [“DFSDCxxx member of the IMS PROCLIB data set” on page 736](#).

- AUTOSIGN indicates that IMS automatically signs on to static terminals with the first LTERM name as the user ID, bypassing a password check. The user ID needs to be defined in RACF.

For ISC static terminals, the SUBPOOL name are used as the user ID instead of the LTERM name.

NOAUTSGN indicates that IMS does not automatically sign on to static terminals with the first LTERM name as the user ID. This is the default.

The AUTOSIGN and NOAUTSGN definitions on the TERMINAL macro override those definitions on the TYPE macro.

If you specify AUTOSIGN on the TYPE macro, every subsequent TERMINAL macro after that TYPE macro also specifies AUTOSIGN. You can specify exceptions to the AUTOSIGN specification by specifying NOAUTSGN for particular TERMINAL macros.

UNITYPE=

Specifies the terminal device type contained in this communication description set.

A terminal defined as either a 3770 or NTO is to be treated as a secondary logical unit type 1 terminal by IMS.

Terminals belonging to a Finance Communication System such as the 3600 Finance Communication System or the 4700 Finance Communication System can be specified as UNITYPE=FINANCE on the TYPE macro statement. Terminals belonging to the 3600 Finance Communication System can also be specified as UNITYPE=3601. The code generated to support the terminal is identical regardless of whether the terminal is specified as UNITYPE=3601 or UNITYPE=FINANCE.

VTAMPOOL macro

The VTAMPOOL macro, which is required for parallel session support, begins the definition of the LU 6.1 LTERM subpools.

You must define VTAMPOOL if any LU 6.1 node uses dynamic LTERM allocation. LTERMs, defined as LU 6.1 nodes, can be a fixed set or may be dynamically allocated depending on the composition of the VTAM macro set. This macro initiates a hierarchy of macros, consisting of a VTAMPOOL statement and one or more subsequent SUBPOOL macros, each of which can optionally be followed by one or more NAME macros (if at least one SUBPOOL statement has an associated NAME statement). This macro set can occur anywhere in the VTAM macro set if it does not break into the TYPE–TERMINAL–NAME statement hierarchy. This macro has no operands.

Dynamic definition

You cannot dynamically define the LU 6.1 LTERM subpools.

Supported environments

The VTAMPOOL macro can be used in the DB/DC and DCCTL environments.

Syntax

➤➤ VTAMPOOL ➤➤

Positional parameters

The VTAMPOOL macro does not include positional parameters.

Keyword Parameters

To find which parameters apply to your IMS configuration, refer to [“Selecting the appropriate macros to define your system” on page 5.](#)

VTAMPOOL

All LU 6.1 SUBPOOLS can be defined under a single VTAMPOOL statement or under multiple VTAMPOOL statements. The only purpose of defining LU 6 SUBPOOLS using multiple VTAMPOOL statements is to aid in documenting the use of each LU 6 SUBPOOL.

Chapter 19. Procedures used in IMS environments

These topics include general information for using IMS procedures.

The specification of IMS procedures

When you specify IMS.SDFSRESL procedures, you must consider where they are stored, whether they need to load the IMS SVC modules, and which IMS environments support the procedures.

For each of the procedures:

- The parameters are listed alphabetically in [“Parameter descriptions for IMS procedures” on page 520](#).
- The DD statements are listed alphabetically in [“DD statements for IMS procedures” on page 583](#).

Storing IMS.SDFSRESL procedures

In IMS 15.4, sample procedures are no longer generated by system definition in the IMS.PROCLIB data set. They are now generated during SMP/E processing and delivered in the IMS.SDFSPROC data set. Users can copy the procedures from IMS.SDFSPROC to IMS.PROCLIB and rename and modify them as necessary so that they match what they would have been if generated in the IMS.PROCLIB. The JCL supplied in the IMSMSG and IMSWT nnn members of the IMS SDFSPROC data set must be modified for your installation requirements and stored in IMS.JOBS.

IMS conforms to z/OS rules for data set authorization. If an IMS job step is to run authorized, all libraries to be used in that job step must be authorized. To run an IMS batch region as unauthorized, a nonauthorized library must be concatenated to IMS.SDFSRESL.

Specifying the DFSRESLB DD statement in IMS batch procedures

Certain batch procedures must load the IMS SVC modules, all of which must be in an authorized library. The DFSRESLB DD statement specifies the library that contains these modules. All libraries that are specified by this statement must be authorized through the Authorized Program Facility (APF).

When you include the DFSRESLB DD statement in a batch procedure, all IMS SVC modules are loaded from the specified library. If this library does not contain the required modules, IMS does not search any other library for the modules and then terminates.

In the batch procedure for your DFSRESLB DD statement, if you identify a specific library from which the IMS SVC modules are to be loaded, this specification does not become the SDFSRESL library search order for the remaining IMS (non-SVC) modules. You must still specify your SDFSRESL library in a JOBLIB or STEPLIB DD statement.

When you do not include the DFSRESLB DD statement in a batch procedure, IMS searches the standard default libraries for the modules (JOBLIB/STEPLIB, followed by LINKLIB). If the IMS SVC modules are not in an authorized library, IMS terminates.

In addition to the DFSRESLB DD statement, the EXEC parameter SRCH, which is allowed on selected batch procedures, also affects the library search order. When SRCH=1, IMS searches the link pack area and directories before searching any other library. When SRCH=0 and the DFSRESLB DD statement is specified, IMS searches only the specified library and does not search the link pack area.

The following modules must be loaded from an authorized library during the IMS batch initialization:

- DFSABND0
- DFSAPMX0
- DFSAPSF0
- DFSAPSFM
- DFSAPSIM
- DFSAPS70

DFSBC000
 DFSCBT10
 DFSDCFC0
 DFSDCFR0
 DFSDMAW0
 DFSDXES0
 DFSFSWA0
 DFSKPXT0
 DFSLMGR0
 DFSLRH00
 DFSMDA00
 DFSMODU0
 DFSMODX0
 DFSMRC00
 DFSMRC20
 DFSRRSBO
 DFSRTM00
 DFSRTMI0
 DFSSPF00
 DFSSTM00
 DFSTOPRO
 DFSVCI00
 DFSVCI10
 DFSV4200
 DFSV4300
 DFSV4400

Procedures and the IMS management of ACBs

When the IMS management of ACBs is enabled, IMS procedures that require access to the application control blocks (ACBs), database definitions (DBDs), or program views (PSBs), automatically retrieve this information from the IMS catalog instead of from ACB, DBD, and PSB libraries.

The enablement of the IMS management of ACBs is determined by the ACBGMGT= parameter in the <CATALOG> section of the DFSDFxxx PROCLIB member or it can be indicated in a batch environment by turning the DXPL_FUNDIREN flag on in the DXPL_FUNCV2 byte in the IMS Catalog Definition exit routine (DFS3CDX0).

Environments that support IMS.SDFSRESL procedures

Table 60 on page 518 shows all the cataloged procedures, control statements, and jobs. Each procedure is listed, followed by the environments in which it applies. Unless noted otherwise, all items in the **Name** column of the table are procedures.

Table 60. IMS.SDFSRESL procedures and the environments in which they apply

Name	DB Batch	TM Batch	DBCTL	DB/DC	DCCTL	Description
DBBBATCH	X	X				A one-step procedure for offline DL/I batch processing regions that use an IMS.ACBLIB or the IMS catalog: “DBBBATCH procedure” on page 601

Table 60. IMS.SDFSRESL procedures and the environments in which they apply (continued)

Name	DB Batch	TM Batch	DBCTL	DB/DC	DCCTL	Description
DBC			X			An online execution procedure to initialize the DBCTL environment: “DBC procedure” on page 604
DBRC			X	X	X	A procedure to execute the DBRC address space: “DBRC procedure” on page 609
DCC					X	An online execution procedure to initialize the DCCTL environment: “DCC procedure” on page 611
DFSJBP	X	X				Starts a JVM non-message-driven dependent region, called a JBP region: “DFSJBP procedure” on page 621
DFSJMP				X		Starts a JVM message-driven dependent region, called a JMP region: “DFSJMP procedure” on page 623
DFSMPR				X	X	A procedure to execute an IMS message processing address space: “DFSMPR procedure” on page 626
DLIBATCH	X	X				A one-step procedure for an offline DL/I batch processing program that uses either PSB and DBD libraries or the IMS catalog: “DLIBATCH procedure” on page 628
DLISAS			X	X		A procedure to execute the DL/I address space: “DLISAS procedure” on page 631
DXRJPROC	X		X	X		A procedure that defines the Internal Resource Lock Manager and its use to the system: “DXRJPROC procedure” on page 633
FDR			X	X		A procedure to execute an FDBR region: “FDR procedure” on page 634
FPUTIL			X	X		A procedure to execute the Fast Path utility program with DEDBs online: “FPUTIL procedure” on page 638
IMS				X		An online execution procedure to initialize the DB/DC environment: “IMS procedure” on page 639
IMSBATCH			X	X	X	A procedure to execute an IMS online batch message processing address space: “IMSBATCH procedure” on page 648
IMSCOBGO	X	X				A three-step compile, bind, and go procedure combining the IMSCOBOL procedure with an execution step for a stand-alone DL/I batch address space: “IMSCOBGO procedure” on page 650
CBLTDLI ²	X	X	X	X	X	Control statements necessary to establish a COBOL-to-DL/I interface.

Table 60. IMS.SDFSRESL procedures and the environments in which they apply (continued)

Name	DB Batch	TM Batch	DBCTL	DB/DC	DCCTL	Description
IMSCOBOL	X	X	X	X	X	A two-step compile and bind procedure for IMS applications written in COBOL: “IMSCOBOL procedure” on page 653
IMSFP				X	X	A procedure for executing a Fast Path application program: “IMSFP procedure” on page 656
IMSMSG ¹				X	X	A job to execute an IMS message processing program: “IMSMSG procedure” on page 657
IMSPLI	X	X	X	X	X	A two-step compile and bind procedure for IMS applications written in PL/I: “IMSPLI procedure” on page 657
IMSPLIGO	X	X				A three-step compile, bind, and go procedure combining the IMSPLI procedure with an execution step for a stand-alone DL/I batch processing address space: “IMSPLIGO procedure” on page 659
IMSRDR			X	X	X	A DASD read procedure to read an IMSMSG job into the operating system job stream from direct access storage devices: “IMSRDR procedure” on page 661
PLITDLI ²	X	X	X	X	X	Control statements necessary to establish a PL/I-to-DL/I interface.
RDIBATCH	X		X	X		A procedure to help maintain database availability in failure situations: “RDIBATCH procedure” on page 662

Notes:

¹ Job

² Control Statement. For information about these control statements, refer to "Establishing a DL/I interface from COBOL or PL/I" in *IMS Version 15.4 Application Programming*.

Related concepts

[“IMS Syntax Checker” on page 381](#)

The Syntax Checker is an ISPF application that helps you define, verify, and validate parameters and their values in the members of the IMS PROCLIB data set. Use the IMS Syntax Checker to avoid typographical and syntactical errors when modifying the parameter values for the IMS PROCLIB data set members.

Parameter descriptions for IMS procedures

All of the parameters that can be specified in startup procedures in the IMS environment are documented in the following subtopics.

ABND= through AUTO= procedure parameters

The procedure parameters ABND= through AUTO=, which are described in the following list, can be specified in procedures in the IMS environment.

ABND= parameter for procedures

Use the ABND= parameter to specify the abend code.

AGN= parameter for procedures

The AGN parameter is ignored. However, it is a positional parameter, so it must remain in the corresponding procedures for compatibility reasons.

ALOT= parameter for procedures

Use the ALOT= parameter in procedures to specify the auto-logout time in minutes. Valid values are 0 and 10 - 1440.

If the ALOT value is not specified, the value from the JCL member is used except for FINANCE, SLU P, and ISC. If ALOT is not specified on the logon descriptor or overridden by the logon exit (DFSLGNX0) for FINANCE, SLU P, and ISC, a value of 1440 is used (the value from the JCL member is ignored).

- **ALOT=0**

The terminal is logged off immediately when no sign-on is in effect. ALOT=0 is normally specified when sign-on occurs by one of the following methods:

- The user is signed on automatically during the logon process (autologon)
- Signon data is supplied by logon (BIND) user data
- Signon data is supplied by the logon exit (DFSLGNX0)

Restriction: Do not specify ALOT=0 for interactive terminal sessions if the session expects a response to the DFS3649 (sign on required) salutation message.

- **ALOT=(10-1439)**

The session is terminated after the specified number of minutes elapses without a signed-on user.

- **ALOT=1440**

The session is never automatically terminated.

ALOT applies only to IMS ETO terminals.

ALTID= parameter for procedures

Use the ALTID= parameter to specify a 1- to 4-character name for an alternate IMS system.

When your IMS message processing region tries to link to an IMS system, it tries to link to the system specified by the IMSID= parameter. If no IMS system matches the name that is specified with IMSID, the message processing region tries the system that is specified with the ALTID= parameter. If no IMS system matches the name that is specified with ALTID=, what happens next depends upon the option you choose on the OPT= parameter.

AOI1= parameter for procedures

Use the AOI1= parameter in procedures to specify the security product and level of security to use for authorization of type-1 AOI commands. Valid values are A, C, N, and R. R is the default.

The default value for this parameter is set during system definition by using either the DCC, IMS, or TRANSACT procedure. Because the AOI1 specification is not included in a checkpoint record, you can change the AOI1 value each time IMS is initialized.

A

Includes options C and R. RACF is called first, and then the system authorization facility (SAF) return code, RACF return code, and RACF reason code are passed to the Command Authorization exit routine (DFSCCMD0). These return codes are decoded into a security code, which is also passed to the user exit DFSCCMD0 for processing.

C

Specifies that DFSCCMD0 is to be called for command authorization.

N

Specifies that no authorization security checking is to be used for this function.

R

Specifies that RACF is to be called for command authorization. R is the default.

AOIP= parameter for procedures

Use the AOIP= parameter in procedures to specify a value for the upper expansion limit of the AOI buffer pool. The value can be specified as 1- to 6-numeric characters, or 1- to 5-numeric characters followed by K (kilobyte), M (megabyte), or G (gigabyte).

If K, M, or G is not specified, K is the default. The maximum value is 2G-1. If the specified value exceeds 2G-1, the default is 2G-1. If a value is not specified, the upper limit default is 2G-1.

AOIS= parameter for procedures

Use the AOIS= parameter in procedures to specify whether RACF, the Command Authorization exit routine (DFSCCMD0), or both are used to secure the DL/I ICMD call in AO applications. Valid values are A, C, N, R, and S. N is the default.

Because AOIS is not included in the checkpoint record, you can change the AOIS value each time IMS is initialized.

The possible values are:

A

Includes options C and R. RACF is called first. Then, the security authorization facility (SAF) return code, RACF return code, and RACF reason code are passed to DFSCCMD0. These return codes are decoded into a security code, which is also passed to DFSCCMD0 for processing.

C

Specifies that DFSCCMD0 is to be called for command authorization.

N

Specifies that the DL/I call ICMD cannot be issued by an application program. N is the default.

R

Specifies that RACF is to be called for command authorization.

S

Specifies that no authorization checking is to be done.

APAR= parameter for procedures

Use the APAR= parameter in procedures to specify the maintenance level of the failing module for searching the APAR.

APARM= parameter for procedures

Use the APARM= parameter in procedures to specify the 1- to 32-character parameter passed to the application program as part of the information returned in the INQY call with the ENVIRON or ENVIRON2 subfunctions.

Note: The PARM=() specified on the EXEC PGM=DFSRR00 statement is limited to 100 characters. Thus, if you start a dependent region with other positional parameters that follow APARM=, the number of APARM characters you can specify might be fewer than 32.

The parameter must be enclosed in single quotation marks (') if special characters are used. Embedded commas (,) are not allowed.

APPC= parameter for procedures

Use the APPC= parameter in procedures to specify whether to activate (Y) or not to activate (N) APPC/IMS LU 6.2 support. The default is (N).

The **/STA APPC** command overrides APPC=N. An IMS APPLID override can also be specified by the existing APPLID1= execution parameter during initialization.

APPCSE= parameter for procedures

Use the APPCSE= parameter in procedures to specify the type of APPC RACF security. Valid values are C, F, N, and P. The default is F.

The value that you specify for this keyword has an equivalent value you can specify in the **/SECURE APPC** command. The first character that you specify applies to the APPCSE keyword. The second character that you specify becomes the equivalent value for the **/SECURE APPC** command.

The **/SECURE APPC** command overrides the value that you specify in the APPCSE= keyword.

C (CHECK)

Specifies APPC RACF command and transaction security check.

F (FULL)

Specifies APPC RACF command, transaction security check, and additional security for dependent regions. The default is F.

N (NONE)

Specifies no APPC RACF security within IMS. (Specifying NONE does not affect APPC/MVS RACF security.)

The IMS security exits (DFSCTRN0 and DFSCCMD0) are still called if they are defined to the system.

P (PROFILE)

Specifies the use of APPC transaction security in the TP profile or the default profile.

APPLFE= parameter for procedures

Use the optional APPLFE= parameter in procedures to specify a 1 to 8-character name of an application front-end routine that is called whenever a message processing program (MPP) is scheduled in a message processing region (MPR).

If APPLFE= is specified, the IMS MPP controller performs the following functions:

- Loads the application front-end routine.
- Calls the application front-end routine for initialization processing.
- Calls the application front-end routine when an MPP is scheduled in an MPR.
- Calls the application front-end routine for shutdown processing when the MPP terminates.

The following describes the interface between the IMS MPP controller and the application front-end routine:

1. The IMS MPP controller calls the application front-end routine for initialization processing with the input registers set as follows:
 - R0=0
 - R1=0
 - R13=address of caller's save area
 - R14=return address of caller
 - R15=entry point address of the application front-end routine

The application front-end routine must restore all registers, except register 15, upon return to IMS. Register 15 contains the return code.

2. The IMS MPP controller calls the application front-end routine when an MPP is scheduled in an MPR with the input registers set as follows:

- R0=entry point address of the application MPP
- R1=PCB list to be passed to the application MPP
- R13=address of caller's save area
- R14=return address of caller
- R15=entry point address of the application front-end routine

The application front-end routine must restore all registers, except register 15, upon return to IMS. Register 15 contains the return code.

3. The IMS MPP controller calls the application front-end routine to perform shutdown processing when the MPP is terminating:

- R0=non-zero
- R1=0
- R13=address of caller's save area
- R14=return address of caller
- R15=entry point address of the application front-end routine

The application front-end routine must restore all registers, except register 15, upon return to IMS. Register 15 contains the return code.

Note: Because the IMS MPP controller establishes an ESTAE, a program interrupt is intercepted and treated as an application failure when it occurs after the application front-end routine is called and before it returns to the IMS MPP controller. As a result, the IMS MPP controller reinitializes itself, and once again loads and calls the application front-end routine for initialization processing. IMS stops the transaction that is responsible for the interrupt.

APPLID1=*name1* parameter for procedures

Use the APPLID1=*name1* parameter in procedures to specify the application identification for the active IMS subsystem.

The VTAM APPLID is overridden by the APPLIDn= startup parameter, and APPLID3 is always used for the tracking subsystem. You must take care not to cause the same IMS VTAM APPLID to be opened for more than one IMS subsystem. If necessary, the APPLID=(*name1,name2,name3*) on the COMM macro should all be overridden by using the APPLID1, APPLID2, and APPLID3 parameters to ensure unique APPLIDS.

In a generic resource group environment, the APPLID1 parameter overrides the value that is specified in the first position of the APPLID= field of the IMS COMM macro. Using this execution parameter allows IMS system definitions to be identical by providing a unique APPLID override when starting the IMS job.

If MNPS is used for XRF systems, the APPLID1 and APPLID2 parameters specify the application identification for the APPLID ACB. The MNPS parameter specifies the application identification for the MNPS ACB.

APPLID2=*name2* parameter for procedures

Use the APPLID2=*name2* parameter in procedures to specify the application identification for the XRF alternate IMS subsystem.

ARMRST= parameter for procedures

Use the ARMRST= parameter in procedures to specify whether (Y) or not (N) IMS registers with z/OS ARM and allows ARM to restart IMS in case of a failure. The default is Y.

ASOT= parameter for procedures

Use the ASOT= parameter in procedures to specify the autosignoff time, in minutes. Valid values are 0 and 10 - 1440.

You can override this value during sign-on with the user descriptor. If ASOT is not specified on either the user descriptor, the logon descriptor, or overridden by either the logon (DFSLGNX0) or sign-on (DFSSGNX0) exits, the value from the JCL member is used except for FINANCE, SLU P, and ISC. If ASOT is not specified on either the user or logon descriptor for FINANCE, SLU P, and ISC, a value of 1440 is used (the value from the JCL member is ignored).

- ASOT=0

The user is signed off immediately when no output is available to be sent. ASOT=0 is normally specified when no IMS input or output is available, or after the last available output message completes.

Restriction: Do not specify ASOT=0 for interactive terminals, for example 3270s or SLU2.

- ASOT=(10-1439)

The user is signed off after the specified number of minutes elapses without terminal activity, irrespective of message status.

- ASOT=1440

The user is never automatically signed off.

ASOT applies only to IMS ETO terminals.

AUTO= parameter for procedures

Use the AUTO= parameter in procedures to specify whether (Y) or not (N) automatic restart is to be invoked. The default is N.

When AUTO=Y is specified, you cannot cold start IMS or modify any restart options before IMS automatically executes either an emergency restart or warm restart, as determined by the circumstances of the prior termination.

BKO= through CSLG= procedure parameters

The procedure parameters BKO= through CSLG=, which are described in the following list, can be specified in procedures in the IMS environment.

BKO= parameter for procedures

Use the BKO= parameter in procedure to specify whether (Y) or not (N) dynamic backout is to be performed. Valid values are Y, or N. The default is N.

BKO= applies only to pseudoabends. Dynamic backout is to the last sync point. Y applies only if the log data set is assigned to DASD.

BPECFG= parameter for procedures

Use the BPECFG= parameter in procedure to specify an 8-character name for the BPE confirmation parameters PROCLIB member.

This parameter is optional. If it is not specified, the BPE defaults used are no user exits, a trace level of error, and US English as the language. This parameter can be specified only as an execution parameter. If no PROCLIB member is specified, BPE uses default values for all parameters.

BPEINIT= parameter for procedures

Use the BPEINIT= parameter in procedure to specify the name of the module that contains initialization values that are required by BPINI00 to start an address space. This required parameter can be specified only as an execution parameter.

CSLDINIO

The module that contains initialization values for an Open Database Manager address space.

CSLOINIO

The module that contains initialization values for a Common Service Layer Operations Manager address space.

CSLRINIO

The module that contains initialization values for a Common Service Layer Resource Manager address space.

CSLSINIO

The module that contains initialization values for a Common Service Layer Structured Call Interface address space.

CQSINIO0

The module that contains initialization values for a Common Queue Server address space.

DSPBINIO

The module that contains initialization values for a DBRC address space.

FRPINIO0

The module that contains the initialization values for a Repository Server address space.

HWSINIO0

The module that contains the initialization values for an IMS Connect address space.

BSIZ= *buffer_size* parameter for procedures

Use the BSIZ=*buffer_size* parameter in procedure to specify the database buffer size.

You must specify a value large enough to contain the largest defined DEDB control interval size. The value can be 512, 1024, 2048, 4096, or a multiple of 4 KB (4096). The maximum value is 28672.

BUF= parameter for procedures

Use the BUF= parameter in procedure to specify a 1- to 3-digit number defining the number of 1 KB blocks to be used in calculating the size of the OSAM subpools.

This parameter applies only to a DL/I batch environment; it is used only if the DFSVSAMP data set is not supplied or does not include any IOBF control statements.

For more information, see [“OSAM buffer pool compatibility definition” on page 208](#).

CCTCVCAN= parameter for procedures

Use the CCTCVCAN= parameter in procedure to specify whether (Y) or not (N) IMS converts abend code 222 TO 08E when canceling a coordinator controller (CCTL) address space that is connected to IMS. Valid values are Y, or N. The default is N.



Attention: If the CCTL is registered with the automatic restart manager (ARM), converting the abend code to a 08E might result in ARM restarting the CCTL.

N

IMS does not convert abend code 222 to 08E. When you cancel the CCTL, IMS might issue abend code 0113, but only if a DLI call contains an active CCTL thread. N is the default.

Y

IMS converts abend code 222 to 08E. This enables the database resource adapter (DRA) to recover and also prevents IMS from issuing abend code 0113.

CIOP= parameter for procedures

Use the CIOP= parameter in procedure to specify a value for the upper expansion limit of the communication I/O buffer pool.

The value can be specified as 1- to 6-numeric characters, or 1- to 5-numeric characters followed by K (kilobyte), M (megabyte), or G (gigabyte). If K, M, or G is not specified, K is the default. The maximum value is 2G-1. If the value specified exceeds 2G-1, the default is 2G-1. If a value is not specified, the upper limit default is 2G-1.

CKPTID= parameter for procedures

Use the CKPTID= parameter in procedure to specify the checkpoint at which the program is to be restarted.

Enclose the checkpoint ID in single quotation marks if it contains any non-ANSI characters, such as the slash.

Related reading: For more information about specifying values for CKPTID, see [XRST call \(Application Programming APIs\)](#).

You can suppress message DFS681I or DFS0540I each time a checkpoint call is made:

- To suppress message DFS681I, code NOMSG681.
- To suppress message DFS0540I, code NOMSG540.
- To suppress both messages, code NOMSGS.
- To suppress DFS681I and DFS0542I, code NO681542.

The values NOMSG681, NOMSG540, NO681542, and NOMSGS are not valid checkpoint restart IDs.

CL1=,CL2=,CL3=,CL4= parameter for procedures

The CL1=,CL2=,CL3=,CL4= parameter in procedure is a required positional parameter that specifies four 3-digit decimal numbers indicating which classes of messages are to be processed by this message region. The maximum value for a class is 999.

For example, if classes 1, 2, and 3 are to be processed by this region, the **PARM** field must be specified as PARM='MSG,001002003000'.

The sequence of specifying the classes determines relative class priority within the message region. In the example, all class 1 messages are selected for scheduling before any class 2 messages are considered. Class numbers cannot be greater than the maximum number of classes that are specified during system definition.

CLASS= parameter for procedures

Use the CLASS= parameter in procedure to specify the default message class for the job being submitted to the internal reader.

CMDLANG= parameter for procedures

Use the CMDLANG= parameter in procedure to specify the language to be used for IMS command text that is distributed to OM automation clients upon request. This value defaults to ENU for US English.

This parameter affects only the command descriptions that are displayed on a workstation SPOC that requests command text from OM.

The value is not validated at OM initialization time. It is validated only when a CSLOMQR QUERY TYPE(CMDSYNTAX) request is issued. OM attempts to read a partitioned data set (PDS) member in the data set specified by the CMDTEXTDSN= with a member name of "CSLOT" concatenated with the 3 character CMDLANG= value. This is the member that contains the command syntax translatable text. The CMDLANG= value can be overridden on the CSLOMQR request.

This is an optional execution parameter. If specified, it overrides the value specified in the CSLOIxxx PROCLIB member.

CMDMCS= parameter for procedures

Use the CMDMCS= parameter in IMS, DCC or DBC procedures to enable commands to be entered from MCS or E-MCS consoles.

The following table shows the procedures that describe the valid keywords for each online system type.

Table 61. Procedures for online systems

Online system type	Procedure name
DB/DC	IMS
DCCTL	DCC
DBCTL	DBC

The following subparameters apply to the IMS and DCC procedures.

N

Commands cannot be entered from an MCS console. N is the default.

Y

Commands can be entered from an MCS or E-MSC console by entering the command recognition character (CRC) followed by the command text.

R

Commands can be entered from an MCS console in the form CRC followed by the command text. The system calls RACF (or equivalent) to verify that the user ID of the console is authorized to issue the command.

C

Commands can be entered from an MCS console in the form CRC followed by the command text. DFSCCMDO is called to verify that the user ID of the console is authorized to issue the command.

B

Include options R and C. RACF (or equivalent) is called first. After RACF is called, the SAF return code, RACF return code, and RACF reason code are passed to DFSCCMDO. The return codes are decoded into a security code that is also passed to DFSCCMDO. DFSCCMDO determines whether the command is authorized for the user ID of the console.

This is an optional subparameter. If you do not select B, C, or R, commands can be entered from an MCS console. Neither RACF nor DFSCCMDO is called to verify that the user ID of the console is authorized to issue the command.

The following subparameters apply to the DBC procedure.

Y

Commands can be entered from an MCS or E-MSC console by entering the command recognition character (CRC) followed by the command text. Y is the default.

R

RACF (or equivalent) is called to verify that the user ID of the console is authorized to issue the command.

C

DFSCCMDO is called to verify that the user ID of the console is authorized to issue the command.

B

Include options R and C. RACF (or equivalent) is called first. After RACF is called, the SAF return code, RACF return code, and RACF reason code are passed to DFSCCMDO. These return codes are decoded into a security code that is also passed to DFSCCMDO. DFSCCMDO determines whether the command is authorized for the user ID of the console.

Note: CRC for DB/DC does not work for restart commands. The ability to issue IMS commands using the CRC or IMSID in a DB/DC environment is available if the proper specification of the CMDMCS parameter is supplied. However, this does not work for restart commands **/ERESTART** and **/NRESTART**. You must enter these commands the same as before. After restart is complete, you can enter commands by using the CRC or the IMSID.

CMDP= parameter for procedures

Use the CMDP= parameter in procedure to specify a value for the upper expansion limit of the command pool.

Specify the value as either 1- to 6-numeric characters, or 1- to 5-numeric characters followed by K (kilobyte), M (megabyte), or G (gigabyte). If you do not specify K, M, or G, K is the default.

The maximum value that can be specified is 2G-1 (2 gigabytes minus 1 byte). If the value specified exceeds 2G-1, the default is 2G-1. If a value is not specified, the upper limit default is 2G-1.

Some of the DRD commands, for example, use this pool.

CMDSEC= parameter for procedures

Use the CMDSEC= parameter in procedure to specify the security method to be used for OM command security.

The possible values are:

A

Specifies that both RACF (or an equivalent security product) and the OM Security exit are to be called (options E and R). RACF is called first. Then the security authorization facility (SAF) return code, RACF return code, and RACF reason code are passed to the exit. These return codes are decoded into a security code, which is also passed to the exit for processing.

E

Specifies that the OM Security user exit routine is to be called for command authorization.

N

Specifies that no authorization checking is to be done. This is the default.

R

Specifies that RACF (or an equivalent security product) is to be called for command authorization.

This is an optional execution parameter. If specified, it overrides the value specified in the CSLOIxxx PROCLIB member. If not specified, the value in the CSLOIxxx PROCLIB member is used.

CORE= parameter for procedures

This parameter is no longer used. CORE= was replaced by the PIINCR= and PIMAX= execution parameters.

CPLOG= parameter for procedures

Use the CPLOG= parameter in procedures to specify the number of system log records between system-generated checkpoints.

If you do not code CPLOG=, the default number of log records between checkpoints is 500,000. To use a different value, you must specify a value on CPLOG= that meets both of the following requirements:

- It must contain one or more numeric characters followed either by K (for thousand) or M (for million). For example, specify 1K, not 1000.
- It is in the range of 1K to 16M.

K means 1024, and M means 1024*1024, for example, 100K = 102,400 and 1M = 1,048,576.

CPUTIME= parameter for procedures

Use the CPUTIME= parameter in procedure to specify the task timing option for either BMP or Fast Path.

The possible values are:

0

No task timing is performed for this BMP or Fast Path region. A default value is placed in the 07 accounting log record to indicate that no timing was done. This is the default.

N

A 1- to 4-digit number that specifies the maximum task time in minutes to be allowed for the execution of this BMP or Fast Path region. The values can range from 1 - 1440 minutes. If a value of 1440 or greater is specified, a time of 24 hours is used. When *N* is nonzero, the STIMER=1 option is in effect.

For BMP task-timing, the measured time includes the DL/I processing that occurs in the dependent region. This includes CPU time for External Subsystem Attach Facility (ESAF) users such as Db2 for z/OS that continue to process under the TCB of the dependent region. When the dependent region exceeds the specified time, a U0240 abend occurs after the current DL/I call completes. To control the execution time of a BMP, use CPUTIME=N instead of the TIME= of the operating system. If the operating system time limit is included with a job that specifies CPUTIME=N, ensure that the former is a sufficiently higher value to allow for initialization and one completed DL/I call beyond the CPUTIME value. When the CPUTIME=N option is used, the application program must not use the STIMER or TTIMER CANCEL.

For Fast Path programs, the timer is set at the beginning of program invocation. However, message-driven programs are not allowed to exceed the amount of time that is defined for the program to process a single transaction. In this case, CPUTIME=*n* is ignored.

CRC= x parameter for procedures

Use the CRC=*x* parameter in procedure to specify a 1-character command recognition character for DBCTL, DB/DC or DCCTL. Commands that are entered at a z/OS system console with the CRC as a prefix, are processed by the control region that has the CRC defined.

CRC overrides the value that is specified on the CMDCHAR keyword of the system definition IMSCTRL macro.

If CMDCHAR is not specified, and CRC is not specified, the default value is /.

If CMDCHAR=NONE is specified, and CRC= is not specified, commands to the DBCTL control region are prefixed by the IMSID.

The CRC must be different from any other CRC in DBCTL regions already running. Choose an unreserved character that is appropriate for your particular system.

Do not use a comma (,) as a command recognition character.

Do not use less than (<) or greater than (>) as a command recognition character. The results would be unpredictable, because the Operations Manager (OM) uses these characters in its XML output.

Do not use a character for the CRC that is the same as the beginning character of a z/OS command. If the CRC is the same as the beginning character of a z/OS command, that command does not work after you start IMS. For example, if you start IMS with CRC=D, z/OS does not respond to any of the z/OS display commands such as D A,L.

The CRC value that you select might affect multisegment command processing. The last character of the command is checked during multisegment command processing. If that character matches the CRC, the command is assumed to be a multisegment command. Processing of the command waits for the rest of the command. For example, if you use B for the command recognition character, and issue the command 'BMODIFY PREPARE ACBLIB', the command does not run. The ending 'B' in 'ACBLIB' is interpreted to indicate a multisegment command. To enter this command correctly, enter:

```
'BMODIFY PREPARE ACBLIB . '
```

CSAPSB= parameter for procedures

When the DL/I address space option (LSO=S) is specified, two program specification block pools are used. CSAPSB specifies the size of pool in the z/OS common storage area (CSA), and DLIPSB specifies the size in the DL/I address space. In an LSO=S system, the PSB= parameter is ignored.

The output of the ACBGEN utility indicates maximum CSA space, average CSA space, and the CSA space required by each PSB in the pool. This output is useful in determining what value to specify for the CSAPSB= parameter. Similarly, before specifying the DLIPSB= parameter, you should consider the secondary address space (SAS) size that is required for each PSB, maximum SAS space, and average SAS space. Neither parameter should be zero. Normally, DLIPSB should be larger than CSAPSB.

The values for the pool sizes can be specified as either 1- to 6-numeric characters, or 1- to 5-numeric characters followed by either K (kilobyte), M (megabyte), or G (gigabyte). If K, M, or G is not specified, K is the default. The maximum value is 2G-1. The upper limit defaults to 2G-1 if any of the following statements are true:

- The specified value is not large enough to hold the largest primary and secondary storage allocations that are defined.
- The specified value exceeds 2G-1.
- No value is specified.

The sizes that are specified are rounded up to the nearest page boundary.

For the FDR procedure, the sum of the values for the CSAPSB and DLIPSB defines the PSB pool size. If PSB is also specified, the larger value (PSB or the sum of CSAPSB and DLIPSB) is used.

For CSAPSB and PSBW, DFSIINS0 obtains contiguous space in the z/OS common area. If this storage is unavailable in the z/OS common area, ABENDU0717 occurs.

CSLG=xxx parameter for procedures

Use the CSLG=xxx parameter in procedure to specify a 3-character suffix for the Common Service Layer IMS.PROCLIB member, DFSCGxxx.

When you specify this parameter, IMS uses the Common Service Layer (CSL) to manage and operate the IMSplex. The minimum configuration for the CSL is to have one SCI and one OM on each z/OS image where an IMS control region resides.

This parameter must be explicitly specified. There are no default values.

CSSLIB= parameter for procedures

Use the CSSLIB= to specify the name of the z/OS callable services library data set, which corresponds to the **CSSLIB** parameter of the IMSGEN macro

DBBF= through DIRCA= procedure parameters

The procedure parameters DBBF= through DIRCA=, which are described in the following list, can be specified in procedures in the IMS environment.

DBBF= parameter for procedures

Use the DBBF= parameter in procedure to specify the maximum number of Fast Path buffers.

Storage is obtained as needed from either:

- The extended common storage area (ECSA).
- FDBR private storage, if the default value FPBUFF=LOCAL is specified in the DFSFDRxx IMS.PROCLIB member.

You can adjust the ECSA or region to meet your requirements. If you do not specify a value for DBBF, IMS uses a default of 10 buffers. If you specify a value for DBBF, IMS overrides the default with your value, and you must adjust for any change in DBFX specification.

The maximum number of Fast Path buffers can vary based on the buffer size (BSIZ):

Buffer size (BSIZ)	Maximum number of Fast Path buffers
512	4 000 000
1024	2 000 000
2048	1 000 000
4096	500 000
8192	250 000
12 288	175 000
16 384	130 000
20 480	100 000
24 576	87 000
28 672	74 000

If the Fast Path 64-bit buffer manager is enabled, IMS sets the initial total number of buffers for the 64-bit subpools to 25% of this value.

DBD= parameter for procedures

Use the DBD= parameter in procedure to specify the Fast Path Data Entry Database (DEDDB) DBD name. DBD= can be 1 - 8 characters.

DBFP= parameter for procedures

Use the DBFP= parameter in procedure to specify a 1- to 4-digit value that determines how often the IMS Fast Path buffer pool manager can page free unneeded buffers. The default value of 0 indicates that any unneeded buffers are page freed at each dependent region termination.

This parameter applies only to the Fast Path buffer pool as defined by the DBBF, DBFX, and BSIZ parameters. It is not valid for the Fast Path 64-bit buffer manager.

Specifying a value for this parameter can improve z/OS performance when many IMS dependent regions with NBA and OBA specified are started and terminated in a short time period (for example, within a period of 1 second). When many page-fixed buffers exist within the z/OS system, specifying a value for this parameter can decrease the z/OS overhead that is required to page fix and page free buffers.

This parameter alters only the method of managing the page fixing and page freeing of the IMS Fast Path buffers in the IMS Fast Path buffer pool. It does not affect the number of buffers in the buffer pool.

0

Allows the number of page-fixed buffers to fluctuate at each termination.

1

Allows the number of IMS Fast Path page-fixed I/O buffers to increase, without a corresponding free. If this option is selected, the number of page-fixed buffers only increases.

2-3600

Determines how often (in seconds) unneeded buffers can be page freed. During this time interval, the number of page-fixed buffers only increases; no page freeing is performed. When the specified time interval expires, the number of page-fixed buffers is reset to the minimum number of buffers needed to satisfy the current requirements.

DBFX= parameter for procedures

Use the DBFX= parameter in procedure to specify a 1- to 5-digit number of additional buffers (not separate pools) from DBBF to be set aside and page-fixed at control region initialization. The default value is 10.

This specification allows for asynchronous processing, which ensures that the DEDB updates are held until the associated log buffer is written.

DBLDL= parameter for procedures

Use the optional DBLDL= parameter in procedure to specify the maximum number of BLDL entries to be kept for application modules that are not preloaded. The default is 20. The maximum value allowed is 9999.

For a region that is used to test new or changed programs, set the DBLDL parameter to 0, ensuring that the most current version of the program is loaded for each execution. Specifying the DOPT parameter on the APPLCTN macro disables quick rescheduling.

Related reading: For more information, see references to BLDL in *IMS Version 15.4 System Administration*.

DBRC= parameter for procedures

Use the DBRC= parameter in procedure to specify whether database recovery control is to be used during this execution of IMS.

The possible values for DBRC= are:

C

This value has no meaning except during a batch backout run of IMS. If specified for other than a batch backout run, it is treated as a null.

With DBRC=C, you can back out batch jobs that terminate normally during an execution that includes DBRC, but not IRLM. During batch backout of jobs that terminated normally, IMS performs authorization for databases and then backs out database changes, as is done for jobs that terminate abnormally.

If DBRC=C is specified when the previous execution of IMS included both DBRC and IRLM, batch backout fails if the previous execution completed normally.

N

Specifies that DBRC is not used during this execution unless DBRC=FORCE is defined in DFSIDEF0. Use this command to turn off DBRC before running a batch. If DBRC=FORCE is defined in DFSIDEF0, and if this is not a batch backout execution of IMS, a message is issued, and a nonzero return code is returned.

If this is a batch backout execution of IMS, the DBRC=FORCE specification defined in DFSIDEF0 can be overridden by specifying DBRC=N on the EXEC procedure. Thus, if the previous execution of IMS used DBRC but not IRLM, batch backout executes without DBRC.

Null

Specifies whether DBRC is included, based on the specification in the installation defaults module, DFSIDEF0. If DFSIDEF0 is not used, DBRC=Y is the default.

Y

Specifies that DBRC is used during this execution of IMS.

If the IRLM is not being used, DBRC provides additional database security. If a common RECON data set is shared among subsystems, DBRC allows proper authorization to registered databases so that the subsystems can share data at the database level.



Attention: If DBRC is used to maintain the integrity of databases, DBRC=N should be specified only when DBRC is unavailable or when you are sure that the integrity of databases is not

destroyed. When DBRC=N, before reactivating DBRC, you must register information about the log volumes created while DBRC was inactive.

DBRCGRP=*id* parameter for procedures

Use the DBRCGRP=*id* parameter in procedure to specify the 1- to 3-character identifier (ID) assigned to a group of DBRC instances that access the same RECON data set in an IMSplex.

The DBRCGRP ID must be unique. If no DBRCGRP ID is specified, and the DBRC SCI Registration exit routine (DSPSCIX0) is not being used, a value of '001' is used.

DBRCINIT=*nnn* parameter for procedures

Use the DBRCINIT=*nnn* parameter in procedure to specify a 3-character suffix for the DBRC initialization parameters PROCLIB member, DSPBIxxx. The default suffix is 000.

This optional parameter can be specified only as an execution parameter.

DBRCNM= parameter for procedures

Use the DBRCNM= parameter in procedure to specify the member in SYS1.PROCLIB containing the procedure for the DBRC address space. The default is DBRC.

The IMS control region automatically starts the DBRC procedure, using this specification. The name can be up to 8 characters, the first of which must be alphabetic.

DBRSE= parameter for procedures

Use the DBRSE= parameter in procedure to specify the 8-character RSENAME.

It is used by a primary and an alternate DBCTL region in a "DBCTL standby" configuration, and it must be the same in both DBCTL regions.

A cold start is required for any change to this parameter to take effect.

Related reading: For more information about RSENAME, refer to *IMS Version 15.4 System Administration*.

DBWP= parameter for procedures

Use the DBWP= parameter in procedure to specify the amount of subpool 231 storage to be allocated to the database work area pool.

The value can be specified as either 1- to 6-numeric characters, or 1- to 5-numeric characters followed by either K (kilobyte), M (megabyte), or G (gigabyte). If K, M, or G is not specified, K is the default. The maximum value is 2G-1. If the value specified exceeds 2G-1, the default is 2G-1. The pool size that is specified is rounded up to the nearest page boundary.

If the logical record size is greater than 8K, the DBWP size must be specified as the largest logical record size times the number of active regions.

If the logical record size is less than 8K, the DBWP size must be specified as 8K times the number of active regions.

Note: During DL/I database OPEN/CLOSE processing in a non-batch environment, DL/I separate address space (DLISAS) E-private storage is used instead of the database work area pool.

DC=*nnn* parameter for procedures

Use the DC=*nnn* parameter in procedure to specify the 3-character suffix for the DFSDCxxx member in IMS.PROCLIB. The default is 000.

DFSDCxxx parameters allow the override of the VTAM node name and the LTERM names for the master and secondary terminals that are defined in the system definition.

DEADLOK='iiii,kkkk' parameter for procedures

Use the DEADLOK='iiii,kkkk' parameter in procedure to specify the local deadlock-detection interval in seconds or milliseconds (*iiii*) and the number of local cycles (*kkkk*) that are to occur before a global detection is initiated.

The LOCKTIME parameter in the DFSVSMxx member of the IMS PROCLIB data set is also associated with IRLM deadlock management. See [“Enabling the IRLM lock timeout function” on page 885](#) for more information.

iiii

A 1- to 4-digit number from 1 to 9999 that specifies the length of time in seconds (1 - 99) or milliseconds (100 - 9999) that is used for the IRLM local deadlock detection interval. Values less than 100 are recognized in seconds with 5 seconds being the maximum used. Values from 100 to 9999 are treated as milliseconds and IRLM truncates this to even 100 millisecond increments, with a maximum value of 5000 (5 seconds).

Note: Once IMS TIMEOUT candidates time out, they remain timeout candidates and are presented to the timeout exit each Global deadlock cycle. IMS creates SMF 79.15 records when candidates are presented which are written to the SMF data sets (if enabled). If timeout candidates are found and the value for *iiii* is subsecond, there are many SMF 79.15 records written per second until the tasks are no longer waiting in IRLM.

kkkk

Specifies the number of local deadlock cycles performed before global deadlock detection is performed. The default is 1.

In data sharing environments, IRLM synchronizes all of the DEADLOK values in the group to the values specified on the most recent IRLM to join the group. The DEADLOK value may be changed by starting a member with the values desired, or by issuing the MODIFY irlmproc, SET, DEADLOCK= command.

Recommendation: Make sure that the installation specifies the same value for DEADLOK on all its IRLM start-up procedures, and use the START irlmproc command or the MODIFY command to override this value only when the interval must be changed from its original value.

If all members of a sysplex group do not support subsecond deadlock processing, the value range used by the group is 1 to 5 seconds, with values specified less than 1 second, changed to 1 second.

Recommendation: Specify the same values for the DEADLOK parameter on all your IRLM startup procedures if you do not want the value for the last IRLM to connect to the group to become the value for all.

Deadlock processing time is minimal if the number of locks that are HELD and WAITING is small. However, deadlock processing can affect system performance when IRLM encounters a real deadlock situation.

The amount of time to run deadlock processing is directly proportional to the number of resources HELD (this is a minor time component) plus the number of WAITERS (this is a major time component) on those resources.

If the WAITERS increase as a result of a real deadlock situation, the deadlock must be found as quickly as possible. The larger the number of WAITERS, the longer deadlock processing takes to find and break the deadlock. While deadlock processing is running, nothing else is happening with respect to that particular IRLM! The effect on performance is particularly significant in a Sysplex environment because any IRLM that is running deadlock processing can cause other members to slow down or stop processing if they need this IRLM to process another request.

The previous paragraph might imply that you should have the DEADLOK parameter on the local IRLM set as high as possible, which would cause deadlock processing to run the least. However, if a deadlock situation exists, the faster it is detected and broken, the better the system runs.

Recommendation: Carefully choose a value for the deadlock frequency that is high enough so that deadlock processing runs often enough to resolve deadlock situations and at the same time is low enough so that system performance is minimally affected. If you have many threads that are capable of becoming WAITERS, it is important to find and break that deadlock as quickly as possible before the WAIT chains require deadlock processing to run seconds (or even minutes) to perform a single local deadlock cycle. To find and break the deadlock is especially important in a Sysplex environment where multiple local cycles are required to break each deadlock, which in turn causes WAITERS to back up on all systems.

Recommendation: Monitor your system application programs for the actual number of deadlocks that IRLM had to break. If you find that the number of these deadlocks is low (or non-existent), you could raise the local deadlock value. If, however, you find that there are a lot of deadlocks that needed to be broken, you might consider having a low deadlock value.

Another aspect of deadlock processing and how it affects system performance is the number of locks that are held. IRLM must evaluate all held resources to check for WAITERS. Therefore, the amount of time that deadlock processing takes depends on the number of held resources (more held resources equals more deadlock processing time).

DESC= parameter for procedures

Use the DESC= parameter in procedure to specify the message descriptor code to be assigned to the IMS system console messages.

If the DESC parameter is not specified, the value specified in the IMSCTRL system definition macro is used.

The DESC parameter overrides the value specified on the IMSCTRL macro at system definition time.

DFSDF=xxx parameter for procedures

Use the DFSDF=xxx parameter in procedures to specify the 3-character suffix of the DFSDFxxx PROCLIB member that you want to use for this procedure.

For example, you can use the DFSDF= keyword to specify the member that contains dynamic resource definition (DRD) values to override the defaults. You can also specify the suffix for the DFSDFxxx PROCLIB member in the DFSPBxxx PROCLIB member.

The DBBBATCH and DLIBATCH procedures are included in the procedures that support the DFSDF= parameter.

If the FP 64-bit Buffer Manager is being used on systems that are being tracked by a Fast Database Recovery (FDBR) address space, the DFSDF= keyword must be specified on the FDR procedure.

Related reference

[DBBBATCH procedure \(System Definition\)](#)

[DLIBATCH procedure \(System Definition\)](#)

[FDR procedure \(System Definition\)](#)

[DFSDFxxx member of the IMS PROCLIB data set \(System Definition\)](#)

[DFSPBxxx member of the IMS PROCLIB data set \(System Definition\)](#)

DIRCA= parameter for procedures

Use the DIRCA= parameter in procedure to specify the size of the dependent region interregion communication area (DIRCA). The size specified must be a 3-digit number (for example, 001).

The size specified represents the number of 1 KB blocks of subpool 251 to be reserved to hold a copy of your PCBs.

If you do not specify a DIRCA size, or if you specify a size of 000, IMS uses the system default for this message region. The size of the system default, determined during system initialization, is the maximum

size required for any PSB. If necessary, IMS updates this default when an online change is made or when a dynamic PSB is scheduled.

Normally, you should not specify this parameter. You can use it to reduce the DIRCA size for a region where only PSBs with small DIRCA requirements are scheduled by class scheduling.

The output from message DFS0589I occurring during ACBGEN facilitates DIRCA size calculation. Each PSB has a PCB=value that is the sum of the PCBs within it. The PCB value plus 64 is the required DIRCA size, in bytes.

The Fast Path utility program uses a PSB that contains an I/O PCB and a DB PCB for the DBD specified in the JCL parameters. A DIRCA size of 002 is sufficient to contain the control blocks built for the PSB.

DLINM= through EXVR= procedure parameters

The procedure parameters DLINM= through EXVR=, which are described in the following list, can be specified in procedures in the IMS environment.

DLINM= parameter for procedures

Use the DLINM= parameter in procedure to specify the member in SYS1.PROCLIB containing the procedure for the optional DL/I address space. The default is DLISAS.

If LSO=S is specified, DLINM= automatically starts the DL/I address space procedure. The name can be up to 8 characters, the first of which must be alphabetic.

DLIPSB= parameter for procedures

When the DL/I address space option (LSO=S) is specified, two program specification block pools are used. CSAPSB specifies the size of pool in the z/OS common storage area (CSA), and DLIPSB specifies the size in the DL/I address space. In an LSO=S system, the PSB= parameter is ignored.

The output of the ACBGEN utility indicates maximum CSA space, average CSA space, and the CSA space required by each PSB in the pool. This output is useful in determining what value to specify for the CSAPSB= parameter. Similarly, before specifying the DLIPSB= parameter, you should consider the secondary address space (SAS) size required for each PSB, maximum SAS space, and average SAS space. Neither parameter should be zero. Normally, DLIPSB should be larger than CSAPSB.

The values for the pool sizes can be specified as either 1- to 6-numeric characters, or 1- to 5-numeric characters followed by either K (kilobyte), M (megabyte), or G (gigabyte). If K, M, or G is not specified, K is the default. The maximum value is 2G-1. The upper limit defaults to 2G-1 if any of the following statements is true:

- The value specified is not large enough to hold the largest primary and secondary storage allocations that are defined.
- The value specified exceeds 2G-1.
- No value is specified.

The sizes specified are rounded up to the nearest page boundary.

For the FDR procedure, the sum of the values for the CSAPSB and DLIPSB defines the PSB pool size. If PSB is also specified, the larger value (PSB or the sum of CSAPSB and DLIPSB) is used.

DLQT= parameter for procedures

Use the DLQT= parameter in procedure to specify a 1- to 3-digit number for the size of the dead letter queue, in days. Valid values are from 0 to 365. The default is 60. If you specify a null or invalid value, 60 is assumed.

DMB= parameter for procedures

Use the DMB= parameter in procedure to specify the amount of subpool 231 storage to be allocated to the data management block (DMB) pool.

The value can be specified as either 1- to 6-numeric characters, or 1- to 5-numeric characters followed by either K (kilobyte), M (megabyte), or G (gigabyte). If K, M, or G is not specified, K is the default. The maximum value is 2G-1. If the value specified exceeds 2G-1, the default is 2G-1. The pool size specified is rounded up to the nearest page boundary.

The output of the ACBGEN utility indicates the size of each DMB processed. This output should be examined before specifying the DMB= parameter.

Note:

For IMS, the DMB pool should be large enough to hold all of the non-resident DMBs, as well as any resident DMBs that are changed by the online change function, DDL, or the **IMPORT DEFN SOURCE (CATALOG)** command.

For Fast Database Recovery (FDBR), the DMB pool must be large enough to hold the largest DMB group that is referenced by any one PSB in the system. During FDBR termination processing, FDBR processes each PSB sequentially. While processing a PSB, FDBR loads all of the DMBs that the PSB has intent for into the DMB pool. After the processing for the PSB is complete, the DMBs it references are cleared from the DMB pool and the next PSB is processed.

If you use the same size DMB pool for both FDBR and IMS, consider the needs of both IMS and FDBR when deciding on the size of the DMB pool. If you define a small DMB pool because most or all of the DMBs are defined to IMS as resident, FDBR may encounter problems trying to backout database changes during FDBR take over.

Note: While an IMS DMB pool is used primarily for non-resident DMBs, if a resident DMB (RES=Y) is changed by the online change function, it will also be loaded into the DMB pool until the next IMS restart. Consequently, if you use both resident DMBs and the online change function, make your IMS DMB pools large enough to accommodate both the non-resident DMBs and any resident DMBs that might be changed in the future by the online change function, DDL, or the **IMPORT DEFN SOURCE (CATALOG)** command.

DMHVF= parameter for procedures

Use the DMHVF= parameter in procedure to specify (in megabytes) how much storage in the Fast Path DEDB VSO emergency restart data space is to be page fixed. Valid values are from 0 to 99.

This startup parameter is valid only on an XRF tracking system. The emergency restart data space is deleted at the end of the XRF takeover. At that time, the storage is also page freed.

DPRTY= parameter for procedures

This parameter is ignored by z/OS, but retained in IMS for compatibility.

Related reading: For details on DPRTY, see *MVS/ESA Job Control Language Reference*.

DSCT= parameter for procedures

Use the DSCT= parameter in procedure to specify a 1-character suffix identifying the user-supplied descriptor table, DFSDCTy, in IMS.PROCLIB. The default is 0.

DYNP= parameter for procedures

Use the DYNP= parameter in procedure to specify a value for the upper expansion limit of the TM dynamic storage private buffer pool.

The value can be specified as 1- to 6-numeric characters, or 1- to 5-numeric characters followed by K (kilobyte), M (megabyte), or G (gigabyte). If K, M, or G is not specified, K is the default. The maximum value is 2G-1. The upper limit defaults to 2G-1 if any of the following statements is true:

- The value specified is not large enough to hold the largest primary and secondary storage allocations that are defined.
- The value specified exceeds 2G-1.
- No value is specified.

The IMS TM code uses this pool for module dynamic storage.

EMHB= parameter for procedures

Use the EMHB= parameter in procedure to specify a value for the upper expansion limit of the Fast Path expedited message handler buffer pool.

The value can be specified as 1- to 6-numeric characters, or 1- to 5-numeric characters followed by K (kilobyte), M (megabyte), or G (gigabyte). If K, M, or G, is not specified, K is the default. The maximum value is 2G-1. The upper limit defaults to 2G-1 if any of the following statements is true:

- The value specified is not large enough to hold the largest primary and secondary storage allocations that are defined.
- The value specified exceeds 2G-1.
- No value is specified.

EMHL= parameter for procedures

Use the EMHL= parameter in procedure to specify a 1- to 5-digit number for the length of the Fast Path expedited message handler buffer.

If no buffer length is available from either the TRANSACT or APPL macro or, in the case of a static terminal, an FPBUF specification, this EMHL buffer length is used. Valid values are from 12 to 30720. The default is 2K. If you specify a null or invalid value, 2K is assumed.

ENVIRON= parameter for procedures

Use the ENVIRON= parameter in procedure to specify the name of the PROCLIB member that contains the JVM environment settings. A sample member DFSJVMEV is supplied in the IMS sample library. ENVIRON is a required parameter. However, this parameter is ignored if the //STDENV DD statement is present.

This parameter can be specified for non-Java dependent regions (MPPs, BMPs, and IFPs) also, in order to create and manage the JVM in MPP, BMP, and IFP regions.

For a description of the required and optional JVM environment settings that you can specify in the PROCLIB member, see [“DFSJVMEV \(JVM environment settings member\)” on page 841.](#)

EPCB= parameter for procedures

Use the EPCB= parameter in procedure to specify the amount of subpool 231 storage to be allocated to the EPCB pool.

The value can be specified as 1- to 6-numeric characters or 1- to 5-numeric characters followed by K (kilobyte), M (megabyte), or G (gigabyte). If K, M, or G is not specified, K is the default. The maximum value that can be specified is 2G-1. If the value specified exceeds 2G-1 the default is 2G-1. The pool size specified is rounded up to the nearest page boundary.

If Fast Path is not generated, the EPCB pool is not allocated. If Fast Path is generated, an EPCB pool is required when the PSB, used by the IMS dependent region, has PCBs for Fast Path databases. This is true regardless of whether the region ever makes a call to these Fast Path databases. If nothing is specified on the EPCB= parameter and if Fast Path is generated, the default pool size is 8K.

ETO= parameter for procedures

Use the ETO= parameter in procedure to specify whether IMS Extended Terminal Option (IMS ETO) is enabled. Valid values are N, M, and Y. The default is N.

N

Specifies that terminals that are not defined to IMS have session initiation attempts rejected. Logon user data is not supported for static terminals; any user data provided at logon time is ignored.

M

Specifies that terminals that are not defined to IMS have session establishment attempts rejected. Logon user data is supported for static terminals; any user data provided at logon time allows automatic sign on to occur during session initiation.

Y

Specifies that terminals that are not defined through the system definition process can establish sessions with IMS if the following conditions are true:

- The terminal type is supported by IMS for dynamic allocation.
- A default logon descriptor (provided either by IMS or by you) has sufficient information to create the control blocks necessary to accept the session request.
- The IMS ETO is installed.

EXCPVR= parameter for procedures

Use the EXCPVR= parameter in procedure to specify whether (1) or not (0) the OSAM Database Buffer Pool is to be page fixed. A value of 0 or 1 must appear in the generated JCL statement for this parameter.

EXVR= parameter for procedures

Use the EXVR= parameter in procedure to specify whether (1 or Y) or not (0 or N) the Queue Manager buffer pools are to be long-term page fixed.

FBP= through HSBMBR= procedure parameters

The procedure parameters FBP= through HSBMBR=, which are described in the following list, can be specified in procedures in the IMS environment.

FBP= parameter for procedures

Use the FBP= parameter in procedure to specify the amount of subpool 0 storage to be allocated to the message format buffer pool.

The value can be specified as 1- to 6-numeric characters or 1- to 5-numeric characters followed by K (kilobyte), M (megabyte), or G (gigabyte). If K, M, or G, is not specified, K is the default. The maximum value that can be specified is 2G-1. If the value specified exceeds 2G-1 the default is 2G-1. The pool size specified is rounded up to the nearest page boundary.

FDRMBR=xx parameter for procedures

Use the FDRMBR=xx parameter in procedure to specify the 2-character suffix for the FDR member DFSFDRxx in the IMS.PROCLIB.

Restriction: When you specify the FDR parameter on the IMS and DBCTL procedures you must also specify IRLM=Y.

FESEXIT= parameter for procedures

Use the FESEXIT=N|Y parameter in procedure to specify whether the Front End Switch exit routine, DFSFEBJ0, is to be loaded by the IMS system.

The default is N.

If FESEXIT=Y is specified, then the FESTIM= keyword can be used to specify the FES timeout value. If FESTIM= is not specified, then the default of 30 is used. The FES exit routine must be placed in an authorized library in the JOBLIB, STEPLIB, or LINKLIST library concatenated in front of the IMS.SDFSRESL. If FESEXIT=N, or the exit routine cannot be loaded, then IMS will issue message DFS4864W for any terminals that have been defined to use Front End Switch (OPTIONS=FES).

FESTIM= parameter for procedures

Use the FESTIM= parameter in procedure to specify the timeout value in seconds to be used for front-end switching.

The minimum value is 1, the maximum value is 300. If this parameter is not specified, the default is the value specified at system definition.

FIX=xx parameter for procedures

Use the FIX=xx parameter in procedure to specify the 2-character suffix for DFSFIXxx and DFSDRFxx.

This parameter specifies the IMS.PROCLIB member to control both of the following:

- Page fixing portions of the control program
- Loading portions of the control program into DREF storage

For information about defining the content of these members, see [“DFSFIXnn member of the IMS PROCLIB data set”](#) on page 830.

FMID= parameter for procedures

Use the FMID= parameter in procedure to specify the component's FMID to search on the preventive service planning (PSP) database.

FMTO= parameter for procedures

You can use the FMTO= parameter in procedure when you want to specify the type of dump output to be produced.

FMTO options

You can use the following codes as the values for the FMTO parameter. The values and their effect on the dumps produced are summarized in the following table:

<i>Table 62. The FMTO parameter values</i>	
Parameter value	Effect on dump produced
TE	Terminating error. Error will terminate IMS.
NT	Non-terminating error. Error will not terminate IMS.
FDDL	Formatted dump delete list processing.
Y	Yes, the dump will be produced.
S	Yes, the dump will be produced only if the SDUMP fails.
N	No, the dump will not be produced.
—	Not applicable, or not attempted to produce a dump.

You can find additional information about the other parameter values that you can use to produce either online or offline dumps, see [Dump formatting options \(Diagnosis\)](#).

FP= parameter for procedures

Use the FP= parameter in procedure to specify whether Fast Path is enabled. Valid values are N, and Y. The default is N.

You can only change the FP value at IMS cold start. If IMS is either warm started or emergency restarted with a different FP value, restart terminates.

The FP value must be the same on the active IMS system and the tracking system (XRF or FDBR). If the tracking system has a different FP value from the active system, it terminates.

N

Fast Path is not enabled. All other Fast Path execute parameters are ignored. This is the default. However, if FP=N, and you attempt to use a Fast Path resource or command, results are unpredictable.

Y

Fast Path is enabled.

FPOPN= parameter for procedures

Use the FPOPN= parameter in procedure to specify whether to reopen DEDB areas automatically during IMS restart. Valid values are N, P, R, A, and D. The default is N.

N

Specifies that areas should not be reopened automatically during IMS restart. Areas that are registered with DBRC for preopening are preopened before the completion of an IMS start or restart as usual; other areas are not preopened.

This is the default.

P

Specifies that after an IMS normal or emergency restart, IMS should preopen those areas that are registered with DBRC to be preopened asynchronously and concurrently with normal IMS online processing.

R

Specifies that during IMS emergency restart, IMS should automatically reopen all areas that were open at the time of the previous IMS failure.

IMS reopens the areas after restart processing is complete. Reopening the areas occurs asynchronously and concurrently with normal IMS online processing.

During IMS normal restart, this option behaves the same as option P.

A

Specifies that during IMS emergency restart, IMS should automatically reopen all areas that were open at the time of the previous IMS failure. This option also specifies that IMS should preopen those areas that are registered with DBRC to be preopened.

IMS reopens the areas after completing restart processing. Reopening and preopening the areas occurs asynchronously and concurrently with normal IMS online processing.

During IMS normal restart, this option behaves the same as option P.

D

Specifies that during IMS control region initialization, the DEDB area preopen process is disabled. Areas that are defined to DBRC with the PREOPEN option are not opened. The open process occurs when the dependent region first requests data or when a **/STA AREA** command is issued after restart is complete. This option is valid for an IMS cold start, normal restart, and emergency restart. This option has no effect on an XRF tracking system or an FDBR system.

The FPOPN option does not change any area options in DBRC. This includes PREOPEN, VSO, and PRELOAD. These options remain set in the RECON data set.

This option does not affect DEDB forward recovery (REDO) processing. If an area requires forward recovery during an emergency restart, the area is opened, updated, and then closed.

FPRLM= parameter for procedures

Use the FPRLM= parameter in procedure to specify whether to restart DEDB areas automatically during IRLM reconnect. Valid values are N, P, S, R, and A. The default is N.

N

Specifies that areas should not be restarted automatically during IRLM reconnect. All DEDB areas remain stopped and unopened until you issue a **/START DATABASE** or **/START AREA** command.

This is the default.

P

Specifies that after IRLM reconnect, IMS preopens those areas that are registered with DBRC to be preopened asynchronously and concurrently with normal IMS online processing.

S

Specifies that after IRLM reconnect, IMS automatically restarts (but does not reopen) all areas that were started at the time of the IRLM failure.

IMS restarts the areas after IRLM completes reconnect processing. Restarting the areas occurs asynchronously and concurrently with normal IMS online processing.

R

Specifies that during IRLM reconnect, IMS automatically restarts and reopens all areas that were open and started at the time of the IRLM failure. After IRLM reconnects, IMS restores all DEDB areas to their state at the time of the IRLM failure, restarting and reopening DEDB areas regardless of whether the DEDB areas have preopen status.

IMS restarts the areas after IRLM completes reconnect processing. After IMS restarts all the areas that were started at the time of the IRLM failure, IMS reopens them. If an area is not yet reopened when an IMS application program requests access, it is reopened immediately.

Restarting and reopening the areas occurs asynchronously and concurrently with normal IMS online processing.

A

After IRLM reconnects, IMS restarts and reopens all DEDB areas that were open at the time of the IRLM failure and all DEDB areas that have a preopen status, even if they were closed at the time of the IRLM failure. IMS restores the DEDB areas asynchronously to the resumption of application processing.

FPWP= parameter for procedures

Use the FPWP= parameter in procedure to specify the value representing the upper expansion limit of the Fast Path work pool.

The value can be specified as 1- to 6-numeric characters or 1- to 5-numeric characters followed by K (kilobyte), M (megabyte), or G (gigabyte). If K, M, or G is not specified, K is the default. The maximum value that can be specified is 2G-1. If the value specified exceeds 2G-1 the default is 2G-1. If a value is not specified, the upper limit default is 2G-1.

FRE= parameter for procedures

Use the FRE= parameter in procedure to specify a 1- to 5-digit number of fetch request elements used to load MFS blocks into the message format buffer pool.

GEN= parameter for procedures

Use the GEN= parameter in procedure to specify a general argument string.

GRNAME= parameter for procedures

Use the GRNAME= parameter in procedure to specify a 1- to 8-character name of the z/OS cross-system coupling facility group for IMS Open Transaction Manager Access (OTMA).

The group name should be alphanumeric (uppercase only) or specified with the following special characters: #, \$, @.

The OTMA XCF group name must be unique within an IMSplex. The first three characters must not conflict with any other IMS XCF group names. Some known IMS XCF group names are:

- DFSxxxxx
- FDRxxxxx
- CQSxxxxx
- CSLxxxxx
- TOIxxxxx

For IMS systems that do not use XRF, OTMA uses the OTMANM= parameter as the IMS XCF member name. If OTMANM= is not specified, OTMA uses the non-APPC VTAM LU name (APPLID1) as the member name.

For IMS systems that use XRF, OTMA uses the USERVAR value as the IMS XCF member name.

This parameter is only valid in IMS DB/DC or IMS TM-DB2 environments.

GRSNAME=*generic_resources_group_name* parameter for procedures

Use the GRSNAME=*generic_resources_group_name* parameter in procedure to specify a 1- to 8-byte character name of the generic resources group.

The group name should be specified in uppercase alphanumeric characters, or with the following special characters: #, \$, @. GRSNAME must begin with an alphabetic character. You must specify the same GRSNAME for all IMS systems participating within the same generic resources group.

HIOP= parameter for procedures

Use the HIOP= parameter in procedure to specify a value for the upper expansion limit of the high communication I/O pool.

The value can be specified as 1- to 6-numeric characters or 1- to 5-numeric characters followed by K (kilobyte), M (megabyte), or G (gigabyte). If K, M, or G is not specified, K is the default. The maximum value that can be specified is 2G-1. If the value specified exceeds 2G-1, the default is 2G-1. If a value is not specified, the upper limit default is 2G-1.

HSBID= parameter for procedures

Use the HSBID= parameter in procedure to specify (for XRF systems only) the XRF system identification. One system is associated with digit 1 and one is associated with digit 2. Either can be brought up as an active or an alternate system.

Through this parameter, IMS identifies the master terminal and the message queues that are associated with it. For example, an IMS system with HSBID=1 uses the first master terminal in the stage 1 definition.

Recommendation: Code the HSBID parameter if you are planning to run XRF anytime in the future. Having HSBID coded could save performing an IMS definition at a later date.

XRF requires that two APPLIDs be specified on the system definition COMM macro. XRF also requires that two *nodenames* be specified by the NAME parameter on the TERMINAL macro. These are for the master and secondary master terminal.

If a null value is specified for HSBID (for example, HSBID=' '), XRF is disabled. Changing the HSBID from usable ('1' or '2') to null or from null to usable requires a cold start.

HSBMBR=xx parameter for procedures

Use the HSBMBR=xx parameter in procedure to specify (for XRF systems only) the 2-character suffix for XRF member DFSHSBxx in the IMS.PROCLIB. The default is 00.

IMS= through LHTS= procedure parameters

The procedure parameters IMS= through LHTS=, which are described in the following list, can be specified in procedures in the IMS environment.

IMS=ims_id parameter for procedures

Use the IMS=ims_id parameter in procedure to specify the subsystem IMS ID.

IMSGROUP= parameter for procedures

Use the IMSGROUP= parameter in procedure to specify a 1- to 4-character IMS group name.

This parameter is user-generated and is typically the IMSID value most often found in the BMP or other dependent region PROCLIB members. There is no default value. If no IMS group name is specified, the z/OS name token is *not* built.

The IMSGROUP= parameter must equal the same value as the IMSID of the BMP regions.

The IMSID of the CTL region should be different because it must be unique within the sysplex. Using the IMSID of the BMP regions as the IMSGROUP= value in the CTL region is to eliminate the need to add any new parameters to the BMP (and other dependent region's) JCL.

Example:

```
CTL Region 1 IMSID=IMS1, IMSGROUP=IMSB
CTL Region 2 IMSID=IMS2, IMSGROUP=IMSB
BMP Region 1 IMSID=IMSB
MPP Region 1 IMSID=IMSB
```

In the example, BMP region 1 connects to either IMS1 or 2 using z/OS names services to find the correct IMSID to use. The IMSID of the BMP JCL is used to construct the z/OS name. This example also holds true for the MPP region and any IFP regions.

The one EXEC parameter, IMSGROUP= is added to the control region procedure.

IMSID= parameter for procedures

Use the IMSID= parameter in procedure to specify a 1- to 4-character IMS identifier for the IMS control region, IMS dependent regions, or IMS batch region.

For IMS control region: Specifies a 1- to 4-character identifier that is a valid subsystem identifier to the operating system being used. It overrides the identifier specified at the time of system definition of the running IMS system.

For IMS dependent regions: Specifies a 1- to 4-character identifier that is a valid subsystem identifier to the operating system to which this dependent region connects. It overrides the identifier specified at the time of system definition of the running IMS system.

For IMS batch region: Specifies a 1- to 4-character IMS identifier that is used in IMS messages that are written to the system log. It overrides the identifier specified at the time of system definition of the running IMS system.

Recommendation: Specify a unique IMSID for each batch region. This helps to avoid confusion as to which region has issued a console message.

Do not use characters for the IMSID that match the beginning characters of a z/OS command. If the IMSID is the same as the beginning characters of a z/OS command, that command does not work after

you start IMS. For example, if you start IMS with IMSID=D, z/OS does not respond to any of the z/OS display commands such as D A, L.

For online control regions, the IMSID must be different from any other IMS subsystem identifier or non-IMS subsystem identifier defined to the operating system under which IMS is running. This identifier is also used to relate messages that are routed to the z/OS system console with the corresponding IMS system. To avoid confusion as to which region has issued a console message, specify a unique IMSID for each batch region. This is however, not a requirement.

The IMSID name must not be the same as the procedure name that starts IMS unless one of the following is true:

- All DD statements in the startup procedure are cataloged in the master catalog.
- The unit and volume are specified on each DD statement.

This parameter cannot be changed at emergency restart.

An IMSID name specified in the FDR procedure identifies the subsystem name for the FDR region.

IMSPLEX=cccc parameter for procedures

Use the IMSPLEX=cccc parameter in procedure to specify the 5-character IMSplex group name, left-justified and padded with blanks, if necessary.

The IMSplex group name is passed to the SCI registration exit routine DSPSCIX0. The sample version of DSPSCIX0 shipped with IMS returns the value that you supply to DBRC as the IMSplex name.

Restriction: If you want to use Automatic RECON Loss Notification but you are not going to use DSPSCIX0, you must add the IMSPLEX= keyword and its value to the DBRC procedure. You must also manually ensure that all IMS instances that use the procedure are in the same IMSplex. This is because the z/OS START command that IMS issues internally does not include an IMSPLEX= value.

Recommendation: Use the SCI registration exit, DSPSCIX0.

IN=input_transaction_code parameter for procedures

Use the IN=input_transaction_code parameter in procedure to specify an input transaction code.

This parameter is necessary only when the application program intends to access the message queues. You cannot schedule a BMP with an IN= parameter specified against a PDIR with an associated SMB that is already scheduled and is SCHDTYP=SERIAL. Doing so results in ABENDU0457 when the BMP is scheduled.

If the IN= parameter is omitted, the BMP is treated as a batch-oriented BMP.

IOB= parameter for procedures

This parameter is no longer used. Requests for I/O are now dynamically allocated.

IOVFI= parameter for procedures

Use the IOVFI= parameter in procedure to specify how often the 'count of unused IOVF control intervals' is updated. The default value is 7200 seconds (2 hours).

This parameter sets a timer, in seconds, which triggers an IMS internal task to begin a count of unused IOVF control intervals.

To disable the timer, specify a time of 1 second. A value of 0 sets the timer to the default value (7200 seconds). The maximum allowed value is 86400 (24 hours).

If the counter task is currently executing and the time interval expires to initiate another counter task, the second count request is ignored. The start time, stop time, and accumulate number of runs and corresponding total time for these runs are tracked in the 59FF logrec.

IRLM= parameter for procedures

Use the IRLM= parameter in procedure to specify whether you want to use the IRLM during this execution. Valid values are Y, and N.

The default for IRLM= depends on the values you specify in the IRLM= and the IRLMNM= parameters of the IMSCTRL macro. If IRLMNM= is not specified on the IMSCTRL macro or on the execution JCL and IRLM= is specified on the execution JCL, then the IRLM name used is *IRLM*.

This parameter cannot be changed at emergency restart.

Y

Indicates that you are using IRLM. This is the default under either of the following conditions:

- The IMSCTRL macro specifies IRLM=Y.
- The IMSCTRL macro specifies an IRLMNM and IRLM=N is not specified.

N

Indicates that you are not using IRLM. This is the default under either of the following conditions:

- The IMSCTRL macro specifies IRLM=N.
- The IRLM= and IRLMNM= keywords of the IMSCTRL macro do not specify a value.

IRLMGRP=*xcf_group_name* parameter for procedures

Use the IRLMGRP=*xcf_group_name* parameter in procedure to specify the name of the XCF group to which this IRLM belongs.

All IRLMs in the same group must specify the same LOCKTAB parameter and an IRLMID value that is unique within the group. The default is IRLMDS.

The group name (IRLMDS by default) is used as the XCF group name. This name cannot start with "SYS" and cannot be the same as the LOCKTAB parameter.

IRLMID= parameter for procedures

Use the IRLMID= parameter in procedure to specify a decimal number that is used to distinguish between IRLMs in a data sharing group. There is no default value. A unique value must be specified for each IRLM in the data sharing group.

The IRLM with the lowest ID number in the group becomes the global deadlock manager for the group when you are in a data sharing module.

You can specify this parameter as either a 1- to 3-digit number from 1 to 255, or as a printable character. You must enclose a printable character with seven single quotation marks on either side of the character. Thus, you must specify the character D as IRLMID='''''''D'''''''. When you specify a printable character, IRLM uses the EBCDIC value of the character as the IRLMID.

IRLMNM=*name* parameter for procedures

Use the IRLMNM=*name* parameter in procedure to specify the 4-byte z/OS subsystem name assigned to this IRLM, or the name of the IRLM started by the IMS online or batch system, depending on the procedure type.

IRLM requires a 4-byte name for its internal processing, even though z/OS can accept names with fewer than 4 bytes for subsystem names.

When used with the DXRJPROC procedure, specifies the 4-byte z/OS subsystem name assigned to this IRLM.

When used with the DBBBATCH, DBC, DLIBATCH, IMS, IMSCOBGO, IMSPLIGO, or RDI procedure, specifies the name of the IRLM started by the IMS online or batch system.

ISIS= parameter for procedures

Use the ISIS= parameter in procedure to specify whether resource access security checking is to be performed. Valid values are A, C, N, and R. If this parameter is not specified, the default specification is ISIS=N.

Note: When **ODBMSECURE=N|A|E|R** is specified, either in the DFSCGxxx member of the IMS PROCLIB data set or in the COMMON_SERVICE_LAYER section of the DFSDFxxx member, the value specified for ISIS= is ignored for any ODBM connecting to the affected IMS subsystem.

A

Specifies that resource access security checking using both RACF and a user exit routine is to be performed.

C

Specifies that resource access security checking using a user exit routine is to be performed.

N

Specifies that no resource access security is to be performed. N replaces values of 0, 1, and 2. If you specify 0, 1, or 2, the system interprets them as ISIS=N.

R

Specifies that resource access security checking using RACF is to be performed.

The Resource Access Security user exit (RASE), if it exists, is loaded in order to provide the extended functionality of the exit.

This parameter cannot be changed at emergency restart.

Related reference

[“DFSCGxxx member of the IMS PROCLIB data set” on page 728](#)

Use the DFSCGxxx member of the IMS PROCLIB data set to specify parameters that are related to the Common Service Layer (CSL), including the Operations Manager (OM), the Resource Manager (RM), and the Structured Call Interface (SCI).

[“COMMON_SERVICE_LAYER section of the DFSDFxxx member” on page 762](#)

The COMMON_SERVICE_LAYER section of the DFSDFxxx member of the IMS PROCLIB data set specifies options for the Common Service Layer (CSL), such as IMSplex name, ACB sharing, global online change, command authorization checking, OLCSTAT, DRD, and global resource status. The section is defined by the header <SECTION=COMMON_SERVICE_LAYER>. The COMMON_SERVICE_LAYER section is valid in DB/DC, DBCTL, and DCCTL environments.

JVM= parameter for procedures

Use the JVM= parameter in procedure to specify the addressing mode of the Java virtual machine (JVM) that is to be loaded into the region and the addressing mode of the associated Language Environment (LE). Valid values are 31, 64, and 3164. The default value is **31**.

31

Specifies that a 31-bit Language Environment enclave and a 31-bit JVM are to be created in the dependent region. When JVM=31, IMS module DFSJVM00 is used to load a JVM.

64

Specifies that a 64-bit Language Environment enclave and a 64-bit JVM are to be created in the dependent region. When JVM=64, IMS module DFSJVM64 is used to load a JVM.

Restriction: The value 64 is valid only for the Java Batch Processing (JBP) regions and Java Message Processing (JMP) regions.

3164

Specifies that a primary 31-bit Language Environment enclave plus a secondary Language Environment managed 64-bit enclave and 64-bit JVM are to be created in the dependent region. This setup is intended

to allow 31-bit COBOL code to call 64-bit Java code or 64-bit Java code to call 31-bit COBOL code. When JVM=3164, IMS module DFSJVM36 is used to load a JVM.

Important: When you specify JVM=3164 on the EXEC statement, verify that the IMS SDFSJLIB data set is part of the dependent region's STEPLIB concatenation. If it is not, the dependent region terminates with ABEND U0101 and Register 15 with the value 'E'x.

The LIBPATH= specified in the //STDENV DD statement or in the ENVIRON= PROCLIB member must point to the Java runtime libraries that match the addressing mode specified on the JVM= parameter: 31-bit Java installation for JVM=31, or 64-bit Java installation for JVM=64 and JVM=3164.

The ENVIRON= parameter is ignored if the //STDENV DD statement is specified on the dependent region procedure.

Important: When you specify JVM= on the EXEC statement for the JMP region, you must explicitly specify the MAXTHRD= and MINTHRD= positional parameters before the JVM= parameter.

Related reference

[ENVIRON= parameter for procedures \(System Definition\)](#)

[DFSJVMEV \(JVM environment settings member\) \(System Definition\)](#)

[“DFSJBP procedure” on page 621](#)

The DFSJBP procedure starts a Java non-message-driven dependent region that resembles a non-message-driven BMP region (for example, similar procedure parameters and z/OS TCB structure).

[“DFSJMP procedure” on page 623](#)

The DFSJMP procedure starts a Java message-driven dependent region that resembles an MPP region (for example, similar procedure parameters and z/OS TCB structure).

JVMOPMAS=*name* parameter for procedures

Use the JVMOPMAS=*name* parameter in procedure to specify the name of the member in the IMS.PROCLIB data set that contains the JVM options for the standalone JVM for Java dependent regions (JBPs and JMPs). However, if the //STDENV DD statement is used, the JVMOPMAS=*name* parameter is ignored.

This parameter can be specified for non-Java dependent regions (MPPs, BMPs, and IFPs) also, in order to create and manage the JVM in MPP, BMP, and IFP regions.

The member name is a maximum of 8 uppercase characters.

The JVM options member must contain either of the following:

1. Specify the **-Xoptionsfile** option to point to the UNIX System Services (USS) file system JVM properties file. The **--Xoptionsfile** option allows you to specify path names that are greater than 255 characters in length on the **-Djava.class.path** option.
2. Specify the **-Djava.class.path** option in the options file to specify the application class path.

If you use the //STDENV DD statement, specify the **-Xoptionsfile** and **-Djava.class.path** in the shell script that is referenced by the DD statement. The JVMOPMAS= parameter is ignored when the //STDENV DD statement is present.

Specify the path name (or path names) of your IMS Java application class files. If your .class files are contained in a .jar file, the path name to the .jar file must be fully qualified, including the name of the .jar file.

Comments are supported for this options member. The comments begin with an asterisk (*) in the first column.

Each line in the options file must not be longer than 72 bytes, including the continuation mark. Use a greater-than symbol (>) at the end of the line as a continuation character.

If you do not use the **-Xoptionsfile** JVM option, path strings can be a maximum of 255 bytes in length (any characters over 255 bytes are ignored). A path string can be one path name or several path names. If you are specifying multiple path names, separate each by a colon (:).

The sample member, DFSJVMMS, demonstrates how to specify the JVM options for Java dependent regions (JBPs and JMPs). For more information about the DFSJVMMS member and examples, see the [DFSJVMMS sample member topic](#).

JVMOPWKR= parameter for procedures

This parameter is obsolete. If it is specified, it is ignored.

LGMSGSZ= parameter for procedures

Use the LGMSGSZ= parameter in procedure to specify a 1- to 5-digit number that represents the size in bytes of a long message record. The length specified is rounded up to the nearest multiple of 4.

Restriction: The length must be greater than or equal to the length specified for the short message record or one and one-half times the maximum message prefix size plus 4. If you specify a value less than the short message record length or one and one-half times the maximum prefix size plus 4, the length of the large message size is set to the greater value between the large message DCB LRECL length, the short message size, or one and one-half times the maximum message prefix size plus 4. The length of the long message record cannot exceed 30632 bytes. If you specify a value greater than 30632, the size is set to 30632. The LGMSGSZ parameter value must be less than or equal to OLDS data set blocksize - 96, larger values will result in user abend U0073.

This parameter is valid only in the shared-queues environment. If you specify a value for the SHAREDQ= parameter, but not for the LGMSGSZ= parameter, the size of the long message record is obtained from whichever is greater: the DCB generated for the long message queue data set or the short message record length.

LGNR= parameter for procedures

Use the LGNR= parameter in procedure to specify the maximum number of Fast Path DEDB buffer alterations that is to be held before the entire control interval is logged.

The parameter is used by Fast Path to build the Fast Path buffer header (DMHR) and to control the DEDB update logging mechanism. The number of DEDB buffer alterations has no direct relationship to the number of DEDB calls. The parameter can be specified as a 1- to 2-digit numeric value from 7 to 99. If a value less than 7 is specified, a minimum value of 7 is set.

LHTS= parameter for procedures

Use the LHTS= parameter in procedure to specify a 1- to 5-digit number of LTERM hash table slots. The default is 256.

Valid values are from 0 to 32767. If you specify a null or invalid value, 256 is assumed.

LOCKMAX= through MNPSPW= procedure parameters

The procedure parameters LOCKMAX= through MNPSPW=, which are described in the following list, can be specified in procedures in the IMS environment.

LOCKMAX= parameter for procedures

Use the LOCKMAX= parameter in procedure to specify a locking limitation. The accepted value range is between 1 and 32767 (in units of 1000). This parameter overrides the PSBGEN LOCKMAX value if one was specified. An override parameter of LOCKMAX=0 turns off all locking limitation.

LOCKMAX=10

Allows for 10000 locks.

LOCKMAX=0

Turns off locking limitation.

LOCKTAB= parameter for procedures

Use the LOCKTAB= parameter in procedure to specify the lock table to be used by this group. This parameter is optional. The default is IRLMLT1.

The lock table must have previously been defined through XCF Resource Manager panels and must be an element of the currently active locking policy.

This parameter must be the same for all IRLMs that specify the same value for the GROUP parameter.

LOGA= parameter for procedures

This parameter is no longer used and is ignored. In earlier releases, it specified whether IMS was to use the BSAM (0) or OSAM (1) logging access method.

LOGT= parameter for procedures

Use the LOGT= parameter in procedure to specify the tape device type where the log data set is to be mounted. The default is device type 2400.

The tape device type specified by the LOGT= parameter substitutes for the device parameter specified in the IEFRDER DD statement.

LSO= parameter for procedures

Use the LSO= parameter in procedure to specify whether to use the Local Storage Option (LSO) or the DL/I subordinate address space option. Valid values are Y, and S. The default is Y.

Y

Specifies that you want to use LSO. With this option, some IMS modules and buffers are moved from the CSA to the private storage area of the control region. This value is the default.

S

Specifies that you want to use the DL/I subordinate address space option. This value is required for a CTL that is connected to an IMS control region or DBCTL region.

LTE= parameter for procedures

Use the LTE= parameter in procedure to specify the number of lock table entries available in the coupling facility lock structure (in units of 1,048,576). LTE can have a value of blank, zero, or any exact power of 2 up to a maximum of 1024.

For example, a value of LTE=32 would result in a lock table size of 64 MB, assuming a width of 2 bytes for each lock table entry. If the value specified on LTE is incorrect, START terminates with DXR116E CODE=24 and ABENDU2018. This value is only used if SCOPE=GLOBAL or NODISCON and has a default of blank (IRLM calculates the value). The number of lock table entries in the group is used in the order outlined in the list, and the width is controlled by the value specified on MAXUSRS. Both of these are dictated by the first IRLM to connect to the group during initial structure allocation or during a REBUILD:

1

The value specified on the MODIFY `irlmproc ,SET ,LTE=` command if greater than zero.

2

The value from the LTE= in the IRLMPROC if greater than zero.

3

The existing logic, which determines the nearest power of 2 after dividing the XES structure size returned on the IXCQUERY call by 2 times the LTE width (based on MAXUSRS).

If an attempt is made to use a nonzero value from either number 1 or number 2 and that value would require more storage than is available in the structure size returned by the XES IXCQUERY issued by IRLM, then the value from the next priority order is used (number 2 or number 3 from the previous list). IRLM does not try to determine how many record table entries the user wants. If the LTE= value

consumes most or all the coupling facility lock structure size available, IRLM allows the connect to succeed.

Note: IRLM supports a maximum of 1024 MB lock entries. If a user specifies a high value for lock structure size in a CFRM policy, IRLM calculates the lock entries for the hash table depending upon the number of users (MAXUSRS) and the structure size, and limits the lock entries to a maximum of 1024 MB.

The following table illustrates some of the commonly desired values for lock table entries and the STORAGE that would be needed for the LOCK TABLE portion as a result. The storage available for record table entries is the INITSIZE minus the storage size listed in this table.

Table 63. Common lock table entry values

For LTE=	Storage if 2-byte entries	Storage if 4-byte entries
8	16 MB	32 MB
16	32 MB	64 MB
32	64 MB	128 MB
64	128 MB	256 MB
128	256 MB	512 MB
256	512 MB	1024 MB

LTERM= parameter for procedures

Use the LTERM= parameter in procedure to specify whether the LTERM name of the static input terminal is used in the DFSAPPC. Valid values are Y, and N. Y is the default.

Y

Specifies that the LTERM is used. Y is the default

N

Specifies that the LTERM is not used. If LTERM=N is specified, and a user ID is not provided or a user is not signed on, the DFSAPPC process is rejected with an error message DFS1957E.

LUMC= parameter for procedures

Use the LUMC= parameter in procedure to specify a value for the upper expansion limit of the LU 6.2 device manager common buffer pool.

The value can be specified as 1- to 6-numeric characters or 1- to 5-numeric characters followed by K (kilobyte), M (megabyte), or G (gigabyte). If K, M, or G is not specified, K is the default. The maximum value is 2G-1. The upper limit defaults to 2G-1 if any of the following statements is true:

- The value specified is not large enough to hold the largest primary and secondary storage allocations that are defined.
- The value specified exceeds 2G-1.
- No value is specified.

The LUM code uses the pool for work area processing.

LUMP= parameter for procedures

Use the LUMP= parameter in procedure to specify a value for the upper expansion limit of the LU 6.2 device manager private buffer pool and OTMA.

The value can be specified as 1- to 6-numeric characters, or 1- to 5-numeric characters followed by K (kilobyte), M (megabyte), or G (gigabyte). If K, M, or G is not specified, K is the default. The maximum value is 2G-1. The upper limit defaults to 2G-1 if any of the following statements is true:

- The value specified is not large enough to hold the largest primary and secondary storage allocations that are defined.
- The value specified exceeds 2G-1.
- No value is specified.

The LUM code uses the pool for work area processing when not processing in the dependent region.

Some of the OTMA and APPC message processing modules have been updated to use DYNP for module dynamic storage. For more information, see the description of DYNP= in [“DYNP= parameter for procedures”](#) on page 538.

MACSYS= parameter for procedures

Use the **MACSYS=** to specify the name for the MACLIB data set to be used in stage 2 assemblies, which corresponds to the **MACSYS** parameter of the IMSGEN macro.

MAXCSA= parameter for procedures

Use the MAXCSA= parameter in procedure to specify the maximum amount of common service area (CSA) and extended CSA (ECSA) that the IRLM for this IMS uses for its lock control block structures.

The acceptable value range is 1M - 999M. IRLM is not prevented from using additional CSA and ECSA for other purposes. You can enter the value in bytes (such as 5242880), or use the abbreviations K for kilobytes (such as 5000K) and M for megabytes (such as 5M).

When PC=YES, the MAXCSA parameter is ignored. A value of zero is allowed in IRLM 2.2.

MAXPST= parameter for procedures

Use the MAXPST= parameter in procedure to specify the maximum number of blocks that the user permits the online control region to allocate.

The default is 255; the maximum is 4095. When system activity increases, IMS allocates PST blocks up to the maximum specified. When the workload diminishes, these blocks are unallocated and storage is released to as low as the value specified by PST=.

An example of how these parameters can be specified follows:

Example:

```
... , PARM= ' PST=48, MAXPST=300, ...
```

Restriction: Reducing the value of the MAXPST parameter from a previous IMS start requires a cold start. Otherwise, results are unpredictable.

MAXTHRD= parameter for procedures

Use the MAXTHRD= positional parameter on the EXEC card of the DFSJMP procedure only when additional positional parameters are specified.

The MAXTHRD value is a 3-digit number. The default is 256. The value of this parameter is ignored by the IMS system. However, for compatibility reasons, you must specify this parameter explicitly when additional positional parameters are provided in the procedure.

Related reference

[“JVM= parameter for procedures”](#) on page 548

Use the JVM= parameter in procedure to specify the addressing mode of the Java virtual machine (JVM) that is to be loaded into the region and the addressing mode of the associated Language Environment (LE). Valid values are 31, 64, and 3164. The default value is **31**.

[“DFSJMP procedure”](#) on page 623

The DFSJMP procedure starts a Java message-driven dependent region that resembles an MPP region (for example, similar procedure parameters and z/OS TCB structure).

MAXUSRS= parameter for procedures

Use the MAXUSRS= parameter in procedure to specify the maximum number of IRLMs that are to connect to the data sharing group. A value from 2 to 248 can be specified.

The initial allocation of locking resources in XES is dependent on the number of entries and the maximum number of users, so some assessment of available resources is made when IRLM joins the group. However, nothing is done to keep the number of users below the specified value.

MBR=*name* parameter for procedures

Use the MBR=*name* parameter in procedure to specify an application program name. The MBR=*name* parameter is required for BMP and IFP jobs.

MCS=(*x,y*) parameter for procedures

Use the MCS=(*x,y*) parameter in procedure to specify the z/OS routing code to be assigned to the IMS system console if multiple console support (MCS) is included in the operating system.

The MCS parameter overrides the value specified on the IMSCTRL macro at system definition time.

Although z/OS supports more than 16 route codes, IMS uses only route codes 1 through 16.

MFSEXITF= parameter for procedures

Use the MFSEXITF=*field-exitnum* parameter in procedure to specify the highest-numbered MFS Field Edit exit routine to be loaded by IMS.

field-exitnum must be a decimal number greater than or equal to 0. It must also be less than the default or specified value for the MFSEXITS=*segment-exitnum* keyword parameter. If MFSEXITF is not less than MFSEXITS, then IMS issues DFS1920I and sets defaults for both keywords. The default is 0.

The IMS-supplied MFS Field Edit exit routine DFSME000 is always loaded. For example, an MFSEXITF=14 specification indicates that the user-supplied MFS Field Edit exit routines DFSME001 through DFSME014, and the IMS-supplied DFSME000, are loaded by the IMS system. The user-supplied exit routines must be placed in an authorized library in the JOBLIB, STEPLIB, or LINKLIST library concatenated in front of the IMS.SDFSRESL. If any exits cannot be loaded, then IMS will issue message DFS1934E for each exit that could not be loaded.

Related reference

[MFSEXITS= parameter for procedures \(System Definition\)](#)

Related information

[DFS1920I \(Messages and Codes\)](#)

[DFS1934E \(Messages and Codes\)](#)

MFSEXITS= parameter for procedures

Use the MFSEXITS=*segment-exitnum* parameter in procedure to specify the lowest-numbered MFS Segment Edit exit routine to be loaded by IMS.

segment-exitnum must be a decimal number less than or equal to 127. It must also be greater than the default or specified value for the MFSEXITF=*field-exitnum* keyword parameter. If MFSEXITS is not greater than MFSEXITF, then IMS issues DFS1920I and sets defaults for both keywords. The default is 127.

The IMS-supplied MFS Field Edit exit routine DFSME127 is always loaded. For example, an MFSEXITS=120 specification indicates that the user-supplied MFS Segment Edit exit routines DFSME120 through DFSME126, and the IMS-supplied DFSME127, are loaded by the IMS system. The user-supplied exit routines must be placed in an authorized library in the JOBLIB, STEPLIB, or LINKLIST library

concatenated in front of the IMS.SDFSRESL. If any exits cannot be loaded, then IMS will issue message DFS1934E for each exit that could not be loaded.

Related reference

[MFSEXITF= parameter for procedures \(System Definition\)](#)

Related information

[DFS1920I \(Messages and Codes\)](#)

[DFS1934E \(Messages and Codes\)](#)

MINTHRD= parameter for procedures

Use the MINTHRD= positional parameter on the EXEC card of the DFSJMP procedure only when additional positional parameters are specified.

The MINTHRD value is a 3-digit number. The default is 000. The value of this parameter is ignored by the IMS system. However, for compatibility reasons, you must specify this parameter explicitly when additional positional parameters are provided in the procedure.

Related reference

[“JVM= parameter for procedures” on page 548](#)

Use the JVM= parameter in procedure to specify the addressing mode of the Java virtual machine (JVM) that is to be loaded into the region and the addressing mode of the associated Language Environment (LE). Valid values are 31, 64, and 3164. The default value is **31**.

[“DFSJMP procedure” on page 623](#)

The DFSJMP procedure starts a Java message-driven dependent region that resembles an MPP region (for example, similar procedure parameters and z/OS TCB structure).

MNPS=*name* parameter for procedures

Use the MNPS=*name* parameter in procedure to specify the name of the MNPS ACB to use for terminal recovery. This parameter is optional and valid only for XRF systems.

If the MNPS=*name* parameter is specified:

- This parameter overrides the MNPS name specified on the DFSHSBxx PROCLIB member.
- The USERVAR specification is ignored.

MNPSPW=*name* parameter for procedures

Use the MNPSPW=*name* parameter in procedure to specify the password to use for the MNPS ACB.

If specified, this parameter overrides the MNPSPW name specified on the DFSHSBxx IMS.PROCLIB member.

VTAM checks this password. If VTAM requires a password during VTAM system definition and no password is specified, then the MNPS ACB cannot be opened.

MOD= through ORSMBR= procedure parameters

The procedure parameters MOD= through ORSMBR=, which are described in the following list, can be specified in procedures in the IMS environment.

MOD=*module_name* parameter for procedures

Use the MOD=*module_name* parameter in procedure to specify the module name, when available.

MON= parameter for procedures

Use the MON= parameter in procedure to specify whether (Y) or not (N) the IMS monitor is to be active for this execution. Valid values are Y, and N.

MSC= parameter for procedures

Use the MSC= parameter in procedure to specify whether the Multiple Systems Coupling (MSC) function is initialized. Valid values are N, and Y. The default is N.

When the MSC= execution parameter is omitted, unless MSC resources are defined by the MSC stage-1 system definition macros, MSC=N is the default. When MSC resources are defined during stage-1 system definition, specifying MSC=Y to initialize MSC is optional.

You cannot change the MSC value before a warm or emergency restart. If IMS is either warm started or emergency restarted with a different MSC value, IMS restart abends.

In an XRF or FDBR environment, the MSC value must be the same on the primary and backup IMS systems.

When IMS initialization or restart completes, IMS issues message DFS1929I, which displays the MSC= value that is currently in effect.

N

Prevents MSC from initializing.

Any defined MSC resources or parameters are ignored. If MSC=N and MSLINK, MSPLINK, and MSNAME resources are defined in the IMSVS.RESLIB DFSCLL3X member that is created by the stage-1 system definition, they are ignored.

Y

Initializes the MSC function even if no MSC links have been defined as part of the system definition process.

When MSC=Y, the SYSID= keyword must be specified in the MSC section of the DFSDfxxx member of the IMS PROCLIB data set.

MSDB=x parameter for procedures

Use the MSDB=x parameter in procedure to specify the 1-character suffix for DBFMSDBx.

See [“DBFMSDBx member of the IMS PROCLIB data set” on page 725](#).

MSG= parameter for procedures

Use the MSG= parameter in procedure to specify the message number for which information is to be searched.

NBA=nnnn parameter for procedures

Use the NBA=nnnn parameter in a procedure to specify a 4-digit number of Fast Path database buffers to be made available when the Fast Path region is activated.

If you are using the Fast Path 64-bit buffer manager, the buffer pools are loaded there. Otherwise, they are loaded into the 31-bit common storage area. DEDBs use these buffers to access VSAM control intervals; MSDBs and DEDBs use them to hold information for updating between the DL/I call and synchronization point.

When the Fast Path 64-bit buffer mode is used, a BMP can use the DEF_NBA parameter of the FASTPATH section. You can specify a value of 1 - 9999. If you specify a value greater than 9999, the 64-bit buffer mode is turned off. You must restart IMS after fixing the value.

These buffers become part of the system database resources, but the number specified is reserved for exclusive use by this region when the application program accesses the MSDBs or DEDBs. Although you are guaranteed access to a number of buffers, a maximum of the combined values of NBA and OBA, you might have to wait for them. The combined values of NBA and OBA also define the maximum number of buffers that the Fast Path 64-bit buffer manager BM can allocate to a dependent region. The default is 0.

NHTS= parameter for procedures

Use the NHTS= parameter in procedure to specify a 1- to 5-digit number of terminal hash table slots. Valid values are 0 - 32767. The default is 256. If you specify a null or invalid value, 256 is assumed.

NLXB= parameter for procedures

Use the NLXB= parameter in procedures to specify the number of parallel sessions to be added during the startup of an IMS system. The default is 0.

The NLXB value is added to the value specified in the SESSION parameter during system definition to increase the number of link extension blocks (LXB) generated for each link control block (LCB).

If NLXB is specified when the maximum value is already specified on the SESSION parameter in the definition of the MSC physical link (MSPLINK), the NLXB value is ignored. This parameter is valid for MSC with VTAM and TCP/IP only and does not apply to Intersystem Communication (ISC).

NODE1= parameter for procedures

Use the **NODE1=** to specify the high-level qualifier of the IMS data sets, which corresponds to the first node name specified in the **NODE** parameter of the IMSGEN macro.

NODE2= parameter for procedures

Use the **NODE2=** to specify the high-level qualifier of the IMS data sets, which corresponds to the second node name specified in the **NODE** parameter of the IMSGEN macro.

OBA=nnnn parameter for procedures

Use the OBA=nnnn parameter in procedure to specify a 4-digit number of additional page-fixed buffers to be made available to a Fast Path application region if the normal allotment is used. The default is 0.

If you are using the Fast Path 64-bit buffer manager, the buffer pools are loaded there. Otherwise, they are loaded in the 31-bit common storage area. In the common storage area, the system page fixes only enough additional buffers to handle the largest overflow specification from all active regions.

When the Fast Path 64-bit buffer mode is used, a BMP can use the DEF_OBA parameter of the FASTPATH section. You can specify a value of 1 - 9999. If you specify a value greater than 9999, the 64-bit buffer mode is turned off. You must restart IMS after you change the value to a valid number.

To prevent a situation in which every program is waiting for buffers when no buffers are available, the system allows only one program at a time to use its overflow allocation. If an application needs more buffers than the combined values of NBA and OBA, it abnormally ends (for message-driven programs) or an FR status code is issued (for non-message-driven programs).

When the 64-bit buffer manager is used, the use of OBA buffers is not serialized. Multiple dependent regions or threads might be using their OBA allocations at the same time, which eliminates a potential bottleneck in buffer use. In practice, it means that each region or thread might be using the number of buffers equal to the combined values of the NBA and OBA specifications.

ODBASE= parameter for procedures

Use the ODBASE= parameter in procedure to specify whether (Y) or not (N) SAF security checking is to be done on an APSB request from an ODBA thread by using the AIMS resource class. Valid values are Y, and N. The default is N.

Note: When **ODBMSECURE=N|A|E|R** is specified, either in the DFSCGxxx member of the IMS PROCLIB data set or in the COMMON_SERVICE_LAYER section of the DFSDFxxx member, the value specified for ODBASE= is ignored for any ODBM connecting to the affected IMS subsystem.

Y

Specifies that a SAF RACROUTE AUTH call is to be made. The AIMS class is used to verify that the user can access the PSB.

The DFSRAS00 user exit, if it exists, is loaded in order to provide the extended functionality of the exit.

N

Specifies that no SAF calls are to be made against the AIMS resource class.

Related reference

[“DFSCGxxx member of the IMS PROCLIB data set” on page 728](#)

Use the DFSCGxxx member of the IMS PROCLIB data set to specify parameters that are related to the Common Service Layer (CSL), including the Operations Manager (OM), the Resource Manager (RM), and the Structured Call Interface (SCI).

[“COMMON_SERVICE_LAYER section of the DFSDFxxx member” on page 762](#)

The COMMON_SERVICE_LAYER section of the DFSDFxxx member of the IMS PROCLIB data set specifies options for the Common Service Layer (CSL), such as IMSplex name, ACB sharing, global online change, command authorization checking, OLCSTAT, DRD, and global resource status. The section is defined by the header <SECTION=COMMON_SERVICE_LAYER>. The COMMON_SERVICE_LAYER section is valid in DB/DC, DBCTL, and DCCTL environments.

ODBMCFG=xxx parameter for procedures

Use the ODBMCFG=xxx parameter in procedure to specify a 3-character suffix for the ODBM configuration parameters PROCLIB member, CSLDCxxx, which includes definitions for the ODBA connection initialization parameters and any ODBM configuration statements. The default suffix is 000.

ODBMINIT=xxx parameter for procedures

Use the ODBMINIT=xxx parameter in procedure to specify a 3-character suffix for the ODBM initialization parameters PROCLIB member, CSLDIxxx. This parameter can only be specified as an execution parameter. The default suffix is 000.

ODBMNAME=odbm_address_space_name parameter for procedures

Use the ODBMNAME=odbm_address_space_name parameter in procedure to specify the name for the ODBM address space.

This is an optional 1-6 character name. If specified, it overrides the value specified in the CSLDIxxx PROCLIB member. You must specify this parameter either as an execution parameter or in the CSLDIxxx PROCLIB member.

OMINIT= parameter for procedures

Use the OMINIT= parameter in procedure to specify a 3-character suffix for the OM initialization parameters PROCLIB member, CSLOIxxx. This parameter can only be specified as an execution parameter. The default suffix is 000.

OMNAME= parameter for procedures

Use the OMNAME= parameter in procedure to specify the name for the OM address space.

This is an optional 1-6 character name. If specified, it overrides the value specified in the CSLOIxxx PROCLIB member. You must specify this parameter either as an execution parameter or in the CSLOIxxx PROCLIB member.

This name is used to create the OMID, which is used in OM processing. The 8-character OMID is the OMNAME followed by the characters "OM". Trailing blanks in the OMNAME are deleted, and the OMID is padded with blanks. For example, if OMNAME=ABC then OMID="ABCOM".

OPT= parameter for procedures

Use the OPT= parameter in procedure to specify what action to take when the dependent region starts, but when no system identifier matches the names given on IMSID or ALTID. Valid values are N, W, and C. The default is N.

The actions are:

N

Ask operator for a decision. This is the default.

W

Wait for the control program to start.

C

Cancel message region automatically.

ORS= parameter for procedures

Use the ORS= parameter in procedure to identify this address space as part of IMS Database Recovery Facility to DFSMVR00 so that the Recovery Data Manager is started.

ORSMBR=xx parameter for procedures

Use the ORSMBR=xx parameter in procedure to specify the 2-character suffix for the IMS Database Recovery Facility member (DFSORSxx) in IMS.PROCLIB that is currently in effect. There is no default.

OTHR= through PIMAX= procedure parameters

The procedure parameters OTHR= through PIMAX=, which are described in the following list, can be specified in procedures in the IMS environment.

OTHR= parameter for procedures

Use the OTHR= parameter in procedure to specify the number of concurrent output threads that Fast Path is to support for the entire Fast Path system.

OTHR= *n* causes a total of *n* service request blocks (SRBs) and extended service request blocks (ESRBs) to be created at system initialization. These blocks are used in scheduling asynchronous DEDB output. If an insufficient number of SRBs is specified, write buffers are queued until one becomes available.

The OTHR= parameter can have any value from 1 to 32,767. If a value is not specified, the default is 255. If 0 or a value greater than 32767 is specified, the default is 2. If a value from 1 to 32767 is specified, the specified value is used.

OTMA= parameter for procedures

Use the OTMA= parameter in procedure to specify whether or not the IMS Open Transaction Manager Access (OTMA) function is to be enabled during IMS initialization. Valid values are Y, N, and M. The default value is N.

Y

IMS uses the security level that is currently in effect (CHECK, FULL, NONE, or PROFILE) to control the RACF security level for input from IMS OTMA clients. You can issue the **/DISPLAY OTMA** command to show the security level that is currently in effect.

If Y is specified, IMS attempts to create an XCF group, specified by GRNAME, during initialization and then attempts to join that group.

N

IMS recovers the **/START OTMA** command across a warm or emergency restart. If a warm or emergency restart of IMS occurs after OTMA has been started by the **/START OTMA** command, OTMA is restarted when IMS is restarted, regardless of the OTMA=N specification.

M

IMS does not recover the **/START OTMA** command across a warm or emergency restart. If a warm or emergency restart of IMS occurs after OTMA has been started by the **/START OTMA** command, OTMA is not restarted when IMS restarts.

If N or M is specified, OTMA is not started during IMS initialization, but can be started later by issuing the **/START OTMA** command.

The **/START OTMA** command is recovered during emergency restart; however, if a **CHKPT** is issued after the **/START OTMA** command is issued, the command is not recovered, and the **/START OTMA** command must be reissued after restart. The **/START OTMA** command is not recovered, in either case, if **OTMA=M** is specified.

After an IMS cold start, the security default is **FULL**.

The **OTMA** parameter is valid only in IMS DB/DC or DCCTL environments.

OTMAASY= parameter for procedures

Use the **OTMAASY=** parameter in procedure to specify whether (Y) or not (N) a non-response transaction originating from a program-to-program switch is to be scheduled asynchronously. Valid values are Y, N, and S. The default value is N.

In a shared-queues environment, the originated transaction usually maintains affinity with the system in which the originating transaction was processed, unless **OTMAASY** is set to S (and **AOS=Y**).

CM0 transactions are always asynchronous and have no affinity.

Restriction: This parameter applies to CM1 synchronous transactions only. This parameter is for send-then-commit messages only.

Y

Specifies that a non-response transaction originating from a program-to-program switch is scheduled asynchronously.

You must define the originating transactions as response or non-response, depending on whether they reply to the IOPCB. The first originated transaction that is scheduled and defined as response can continue the synchronous conversation. If the originated transaction cannot continue the synchronous conversation and neither the originating nor the originated transactions reply to the IOPCB message, DFS2082 is returned to the client.

If all the originated transactions are defined as non-response, and none can continue the synchronous conversation, the client becomes nonresponsive.

By specifying Y, this parameter can be used in the multiple program-to-program switches environment to ensure that only response transactions can be scheduled synchronously.

N

Specifies that a non-response transaction originating from a program-to-program switch is not scheduled asynchronously.

The first originating transaction that is scheduled can continue the synchronous conversation. You cannot predict which of the originated transactions is the first scheduled transaction. This situation can lead to a "race" condition. If the originated transaction cannot continue the synchronous conversation and neither the originating nor the originated transactions reply to the IOPCB message, DFS2082 is returned to the client.

S

Specifies that the first transaction originating from a program-to-program switch performed through ISRT to a ALTPCB (if non-Express) is scheduled synchronously and can continue the synchronous conversation.

If you specify **OTMAASY=S**, the first program-to-program switch that is able to continue the synchronous conversation is synchronous. Every further program switch is asynchronous.

If you specify **OTMAASY=S**, IMS overwrites the **APPCASY** value to S. If you specify **APPCASY=S**, IMS overwrites the **OTMAASY** value.

In a shared-queues environment where the support for synchronous APPC/OTMA is active (AOS=Y), if you specify OTMAASY=S, the program-to-program switch transactions do not have any affinity.

Tip: No DFS2082 is issued for a transaction that is scheduled asynchronously.

OTMAMD= parameter for procedures

Use the OTMAMD= parameter in procedure to specify whether the member override field in the parameter list of the OTMA Prerouting user exit (OTMAYPRX) can be used for a transaction initiated from an OTMA client. Valid values are Y (yes) or N (no). The default value is N.

OTMANM=*member_name* parameter for procedures

Use the OTMANM=*member_name* parameter in procedure to specify the member name that IMS uses when joining the z/OS cross-system coupling facility (XCF) group for non-XRF (Extended Recovery Facility) systems.

For IMS systems without XRF, OTMA uses the OTMANM= parameter as the IMS XCF member name. If OTMANM= is not specified, OTMA uses the non-APPC VTAM LU name (APPLID1) as the member name.

For IMS systems with XRF, OTMA uses USERVAR as the IMS XCF member name.

This parameter is only valid in IMS DB/DC or IMS TM-DB2 environments.

OTMASE= parameter for procedures

Use the OTMASE= parameter in procedure to specify the type of OTMA RACF security that you want to use. Valid values are C, F, J, N, and P. The default is F.

Valid parameter values include:

C

OTMA RACF security is CHECK. IMS commands are checked against the CIMS class. IMS transactions are checked against the TIMS class.

F

OTMA RACF security is FULL. This is the same type of security as CHECK, but additional security checking is performed against dependent regions. The default value is F.

J

OTMA RACF security is JOIN. OTMA performs connection authorization for OTMA clients by using the RACF Facility class IMSXCF .*xcfgroup.member* profile, if it exists. Transaction and command security is not enabled. No calls to RACF are made for IMS transactions and commands.

N

OTMA RACF security is NONE. No calls to RACF are made.

P

OTMA RACF security is PROFILE. Each OTMA message defines the level of security checking to be done.

The **/SECURE OTMA** command overrides the value you specify in the OTMASE= keyword.

If no value is specified, a value of X appears in the initial DFS1929I message that is issued when IMS is started. During IMS restart processing, this value is changed to F. A value of F appears in the active DFS1929I message that is issued when restart processing is complete.

If you do not specify the OTMASE keyword, IMS retains the OTMA security settings (which are established by the **/SECURE OTMA** command) after a warm start or an emergency restart.

After the OTMA client connection is authorized, the transaction or command security checking will be performed based on the security setting in the LUY_RACF_OPT of the message prefix which is set using the OTMA security level. For OTMA security level JOIN (J), the security setting in the message will be NONE for transaction and command processing.

OTMASP= parameter for procedures

Use the OTMASP= parameter in procedure to specify whether a non-synchronous Tpipe or a synchronous Tpipe is created to deliver the OTMA output. Valid values are Y (create a synchronous Tpipe) or N (create a non-synchronous Tpipe). The default value is N.

If the value of this parameter is Y or if the OTMA Prerouting Exit routine (DFSYDRU0) indicates the need for a synchronous Tpipe, the synchronous Tpipe is created.

OUT= parameter for procedures

Specifies the transaction code or logical terminal name to which an output message is to be sent. This parameter is necessary when the application program wants to send output without accessing the input queues. A remote LTERM (CNT) cannot be specified.

OVLA= parameter for procedures

Use the OVLA= parameter in procedure to specify the overlay supervisor option. Valid values are 0 or 1. The default is 0.

The possible overlay supervisor options are:

0

Allow z/OS to load and delete the overlay supervisor for every overlay application program. This is the default.

1

Load and retain a copy of the overlay supervisor when the message region is initialized.

PAGES= parameter for procedures

Use the PAGES= parameter in procedure to specify the amount of primary and secondary space allocated for the SYSPRINT DD statement data set.

PARDLI= parameter for procedures

Use the PARDLI= parameter in procedure to specify the parallel DL/I option. Valid values are 0 or 1. The default is 0.

0

DL/I processing is to be performed within the region. This is the default.

1

All DL/I processing for this region is to be performed in the IMS control region. If data capture (EXIT= on the DBD statement) is enabled and this is a delete, replace, or insert call, PARDLI=1 is ignored for the DL/I call.

PARDLI=1 prevents control region system 113 abends resulting from system X22 abends in the region. If PARDLI=1, parallel DL/I is disabled, which can degrade performance.

Important: Using PARDLI=1 for MPP, JMP, or IFP regions can degrade performance. Use PARDLI=1 for MPP, JMP, or IFP regions only for application debugging purposes, if needed.

PASSWD= parameter for procedures

This parameter is obsolete. Use the PASSWD1 parameter.

PASSWD1= parameter for procedures

Use the PASSWD1= parameter in procedure to specify a password to override the value specified on the PASSWD= parameter in the COMM macro.

PC= parameter for procedures

Use the PC= parameter in procedure to specify where the IRLM lock control block structure is stored in private storage. Regardless of the value, however, IRLM always runs with PC=YES.

When PC=NO, locks are managed in extended common service area (ECSA) with cross-memory services.

With PC=YES, IRLM places the lock storage in the 64-bit private address space.

Note: PC=NO can still be specified in the startup procedure, but IRLM sets PC=YES during initialization .

PCB= parameter for procedures

Use the PCB= parameter in procedure to specify the size of the dependent region interregion communication area (DIRCA); the size specified must be a 3-digit number (for example, *001*) representing the number of 1 KB blocks of subpool 251 to be reserved to hold a copy of your PCBs.

If you do not specify a DIRCA size or if you specify a size of *000*, IMS uses the system default for this message region. The size of the system default, determined during system initialization, is the maximum size required for any PSB. If necessary, this system default is updated when an online change is made or when a dynamic PSB is scheduled.

If you specify this parameter, the specified size is always used. If the size required is larger than the specified size, the region abends with a user 0242 abend code.

Normally, you should not specify this parameter. You can use it to reduce the DIRCA size for a region when PSBs with small DIRCA requirements are scheduled into this region.

The output from message DFS589I occurring during ACBGEN facilitates DIRCA size calculation. Each PSB has a PCB= value that is the sum of the PCBs within it. The PCB value + 64 becomes the required DIRCA in bytes.

PGPROT= parameter for procedures

Use the PGPROT= parameter in procedure to specify whether the IRLM is to place load modules that are resident in common storage into z/OS Page Protected Storage during initialization. Valid values are YES or NO. The default value is YES.

If the load modules are in Page Protected Storage, any application that attempts to overlay the modules is terminated.

PIINCR= parameter for procedures

Use the PIINCR= parameter in procedure to specify the increment to be used in a conditional GETMAIN to obtain the dynamic storage. The default value is 64K.

No storage is allocated for ENQUEUE/DEQUEUE blocks at initialization. The first block of storage, obtained when the ENQUEUE/DEQUEUE routine is first called, is in the increment specified in PIINCR. Storage continues to be obtained in the increment specified until the maximum is reached (see PIMAX=). IMS does not release any storage that is dynamically obtained for the ENQUEUE/DEQUEUE routine. After storage is obtained, it is kept for the duration of the control region execution.

PIINCR can be specified as either 1- to 6-numeric characters, or 1- to 5-numeric characters followed by K (kilobyte), M (megabyte), or G (gigabyte). If K, M, or G is not specified, K is the default. The maximum value is 2G-1. The upper limit defaults to 2G-1 if any of the following statements is true:

- The value specified is not large enough to hold the largest primary and secondary storage allocations that are defined.
- The value specified exceeds 2G-1.
- No value is specified.

PIMAX= parameter for procedures

Use the PIMAX= parameter in procedure to specify the maximum amount of dynamic storage available to the exclusive control of the ENQUEUE/DEQUEUE routine. The default value is 1024K (1M).

No storage is allocated for ENQUEUE/DEQUEUE blocks at initialization. The first block of storage, obtained when the ENQUEUE/DEQUEUE routine is first called, is in the increment specified by PIINCR=. Storage continues to be obtained in the increment specified until the maximum is reached. IMS does not release any storage that is dynamically obtained for the ENQUEUE/DEQUEUE routine. After storage is obtained, it is kept for the duration of the control region execution.

PIMAX can be specified as either 1- to 6-numeric characters, or 1- to 5-numeric characters followed by either K (kilobyte), M (megabyte), or G (gigabyte). If K, M, or G is not specified, K is the default. The maximum value is 2G-1. The upper limit defaults to 2G-1 if any of the following statements is true:

- The value specified is not large enough to hold the largest primary and secondary storage allocations that are defined.
- The value specified exceeds 2G-1.

PRDR= through QTU= procedure parameters

The procedure parameters PRDR= through QTU=, which are described in the following list, can be specified in procedures in the IMS environment.

PRDR=*name* parameter for procedures

Use the PRDR=*name* parameter in procedure to specify the name of the IMSRDR procedure in IMS.PROCLIB, or SYS1.PROCLIB, used in **/START REGION** commands. The name can be up to 8 characters in length. The default is IMSRDR.

PREINIT=*xx* parameter for procedures

Use the PREINIT=*xx* parameter in procedure to specify a 2-character suffix for DFSINTxx, the IMS.PROCLIB member that lists the preinitialization modules that are to receive control.

For details on how to define the member, see [“DFSINTxx member of the IMS PROCLIB data set” on page 839](#).

PREMSG= parameter for procedures

Use the PREMSG= parameter in procedure to specify whether (Y) or (N) you want to receive or suppress the DFS000I prefix message that precedes all DBCTL system messages and command responses. Valid values are Y, or N. Y is the default.

If the DFS000I prefix message is suppressed (PREMSG=N), all system messages are issued with the IMSID appended to the last line. The message can be a single line with a maximum of 121 characters of message text followed by XXXX, where XXXX is the IMSID. Or the message can be multiple lines with each line containing a maximum of 71 characters of message text. The IMSID is appended to the last line of a multi-line message or is the only text of a final line.

Display command output is prefaced by a prefix message:

```
DFS4444I DISPLAY FROM ID=XXXX
```

where XXXX is the IMSID. The message text is in columns 2-71 of all subsequent lines. Column 1 of display output contains + if the message text continues to the next line; otherwise, column 1 is blank.

If PREMSG=Y (the default value) is selected, all system messages and command responses are issued as multi-line messages.

The first line is:

where XXXX is the IMSID. The message starts on the second line.

PRLD=xx parameter for procedures

Use the PRLD=xx parameter in procedure to specify a 2-character suffix for DFSMPLxx, the IMS.PROCLIB member identifying the modules to be preloaded in the region or partition.

For more information about making program modules resident in a region, see [“DFSMPLxx member of the IMS PROCLIB data set”](#) on page 845.

PSB= parameter for procedures

Use the PSB= parameter in **batch procedures** to specify an optional PSB name when the PSB name and application program name are different. Use the PSB= parameter in **online procedures** to specify the amount of subpool 231 storage to be allocated to the PSB pool.

For batch procedures: An optional parameter specifying a PSB name when the PSB name and application program name are different.

The use of generated PSBs (GPSB) is supported in a TM batch environment. If the application program requires a GPSB, it must use the PSB parameter to indicate that request. In this case the PSB parameter does not specify the name of the PSB. Instead, it specifies a code that requests the use of a generated PSB and its language type. The specification of the code as the PSB parameter causes the specified GPSB to be used for the batch application program. The application program name (MBR parameter) is used as the GPSB name. GPSBs are not available in DB batch.

The following coded character strings are used to identify the use of a GPSB and its language:

DFS\$\$ASM

GPSB for the assembler language format.

DFS\$\$COB

GPSB for the COBOL language format.

DFS\$\$PLI

GPSB for the PL/I language format.

DFS\$\$PAS

GPSB for the Pascal language format.

Note: The coded character strings (DFS\$\$xxx) are valid only in an IMS DCCTL environment.

For online procedures: Specifies the amount of subpool 231 storage to be allocated to the PSB pool. The value can be specified as 1- to 6-numeric characters or 1- to 5-numeric characters followed by K (kilobyte), M (megabyte), or G (gigabyte). If K, M, or G is not specified, K is the default. The maximum value that can be specified is 2G-1. If the value specified exceeds 2G-1 the default is 2G-1. The value specified is rounded up to the nearest page boundary. The default is 0.

The output of the ACBGEN utility indicates the maximum PSB size and the size of each PSB processed. This output should be examined before specifying the PSB= parameter.

For the FDR procedure, when LSO=S is specified, the sum of the values for the CSAPSB and DLIPSB defines the PSB pool size. If PSB is also specified, the larger value (PSB or the sum of CSAPSB and DLIPSB) is used.

PSBW= parameter for procedures

Use the PSBW= parameter in procedure to specify the amount of subpool 231 storage to be allocated to the PSB work area pool.

The value can be specified as 1- to 6-numeric characters or 1- to 5-numeric characters followed by either K (kilobyte), M (megabyte), or G (gigabyte). If K, M, or G is not specified, K is the default. The maximum

value that can be specified is 2G-1. If the value specified exceeds 2G-1 the default is 2G-1. If no value is specified, the default value is 32K. The pool size specified is rounded up to the nearest page boundary.

The output of the ACBGEN utility indicates the maximum work area size among the work area sizes required by each PSB. Depending on the execution environment, the work area size for a given PSB may be increased to the size of the long message queue buffer or to the size specified plus the maximum segment size of the segments processed by this PSB. The ACBGEN output should be examined before specifying the PSBW= parameter

For CSAPSB and PSBW, DFSIINS0 obtains contiguous space in the z/OS common area. If this storage is unavailable in the z/OS common area, ABENDU0717 occurs.

PST= parameter for procedures

Specifies the number of partition specification tables (PSTs) to be allocated during system initialization. This number can be between 0 and the number specified on the MAXPST= control region parameter. The default is 0.

Each active dependent region, DBCTL thread, or ODBA thread uses a PST. If additional dependent regions or threads are required during peak periods, IMS dynamically allocates additional PSTs as the dependent regions or threads are started. PSTs can be allocated up to the MAXPST value.

During idle periods, the PSTs are released. The number of PSTs specified on PST= is maintained. For example, if PST=15, it is assumed that approximately 15 dependent regions or threads are always active. During peak periods, if additional dependent regions or threads are started, IMS dynamically allocates a PST for each dependent region or thread, up to the MAXPST value. As PSTs are terminated, the PSTs are released until a value of 15 PSTs is reached. This support is within the constraints of the operating system or subsystem being used.

PSWDC= parameter for procedures

Use the PSWDC= parameter in procedure to specify whether mixed-case passwords are supported. Valid values are M, U, and R. The default is R.

The possible values are:

M

IMS supports the use of mixed-case passwords. If you intend to support mixed-case passwords, be aware of this support wherever you manipulate passwords, such as in exit routines.

U

IMS forces all password to uppercase.

R

IMS uses whatever is defined for mixed-case passwords in RACF. If mixed-case passwords are active in RACF (which is done through the SETROPTS command) then IMS uses it. If mixed-case passwords are not active in RACF, then IMS uses uppercase passwords. Whenever there are changes to the mixed-case password definition in RACF, IMS adjusts without requiring a restart. R is the default.

PWFI= parameter for procedures

Use the PWFI= parameter in procedure to specify the pseudo-wait-for-input (PWFI) parameter. Valid values are Y, or N. N is the default.

Y

Activates pseudo wait-for-input (PWFI). If the application program issues a Get Unique (GU) call to get a message from the IMS message queue, MODE=SINGLE is specified on the TRANSACT macro and no message is available, IMS checks for other work for this region. If no other work is available, instead of returning status QC to the application program, IMS enqueues this region on scheduler subqueue 6 indicating that it is a PWFI region. If the next message is for the transaction scheduled in this MPP region, this region is dequeued from subqueue 6 and posted. IMS then returns the new message to the application program. This eliminates the rescheduling of IMS resources. If the processing limit

(PROCLIM) for the transaction is reached, the application receives a QC status and is expected to terminate. After the application program terminates, it is reloaded on the subsequent schedule.

N

Disables PWF. If the program issues a Get Unique (GU) call to get a message from the IMS message queue but no message is available, the application program receives status QC.

QBUF= parameter for procedures

Use the QBUF= parameter in procedure to specify the 1- to 4-digit number of message queue buffers in subpool 0 to be allocated to the queue pool.

In the shared-queues environment, the number you specify for QBUF= is used as the initial number of message queue buffers allocated to the queue pool. The number of message queue buffers is dynamically expandable in the shared-queues environment. The maximum number you can specify is 9999. If you specify a number lower than 200, or if you do not specify a value, the number defaults to the value that is generated during system definition for the BUFFERS= parameter of the MSGQUEUE macro, or 200, whichever is greater.

QBUFHITH= parameter for procedures

Use the QBUFHITH= parameter in procedure to specify a 1- to 3-digit number from 1 to 100 that establishes the high threshold percentage for the message queue buffer. The default is 80%.

When the buffer reaches the high threshold, it is dynamically expanded.

QBUFLWTH= parameter for procedures

Use the QBUFLWTH= parameter to specify a 1- to 3-digit number from 1 to 100 that establishes the low threshold percentage for the message queue buffer. The default is 50%.

When the message queue buffer reaches the low threshold, it is compressed. Compression only occurs when the number of message queue buffers exceeds the number allocated by system definition.

This parameter is valid only in the shared-queues environment.

QBUFMAX= parameter for procedures

Use the QBUFMAX= parameter in procedure to specify the 1- to 7-digit number that indicates the maximum number of message queue buffers for the queue pool.

The maximum number that you can specify is 9999999.

The value of QBUFMAX cannot be less than the value that is specified on QBUF, which specifies the initial number of queue buffers. If the value of QBUFMAX is less than the value of QBUF, IMS internally sets the value of QBUFMAX to the value of QBUF or to 200, whichever is greater.

If this parameter is not specified or it is specified but it is 0 or an invalid value, the number of buffers in the queue pool is unlimited.

This parameter is valid only in a shared-queues environment.

If the value specified on QBUFMAX is large, for example QBUFMAX=9999999, the number of buffers might never reach the specified number due to 31-bit storage limitations in the control region address space.

Queue Manager allocates the buffers only if storage is available, so the actual number of buffers that the Queue Manager can allocate depends on the amount of storage available in the address space. The amount of storage can be estimated by adding 72 to the size of the message queue buffer and multiplying the total by the QBUFMAX value.

The message queue buffer size can be specified by using QBUFSZ. If the buffer size is not specified, the size is obtained from the large message record size. If an invalid value is specified for QBUFMAX, IMS ignores QBUFMAX and issues message DFS1920I. IMS behaves as if QBUFMAX was not coded

(the maximum number of queue manager buffers allocated depends on the amount of 31-bit storage available).

The QBUFMAX parameter can be modified across an IMS warm start or an IMS emergency restart.

A runaway transaction can use many queue buffers. To limit the number of application program output segments that are inserted by each transaction, you can use the SEGNO parameter on the TRANSACT macro, which can help prevent queue buffer shortage conditions.

Related reference

[“TRANSACT macro” on page 498](#)

Use the TRANSACT macro statement to specify the transaction codes that cause the application program named in the preceding APPLCTN macro to be scheduled for execution in an IMS message processing region.

QBUFPCTX= parameter for procedures

Use the QBUFPCTX= parameter in procedure to specify a 1- to 3-digit number in the range of 1 to 100 that establishes the percentage of the originally allocated message queue buffers that are dynamically expanded when the limit specified by the QBUFHITH= parameter is reached. The default is 20%.

QBUIFSZ= parameter for procedures

Use the QBUIFSZ= parameter in procedure to specify a 1- to 5-digit number that represents the size in bytes of the message queue buffers (in core buffers) used by the queue manager.

You must specify a size greater than or equal to the length specified by LGMSGSZ=. The size must be equal to or less than 30632 bytes, which is the maximum length of the long message record. The size that is specified is rounded up to the nearest multiple of 4. If you specify a value greater than 30632, the size is set to 30632. If you do not specify a value, or if you specify a value less than the length of the long message record, the size is obtained from the record length of the long message record. The DCBs for the message queue data sets are built during IMS system definition processing, even though the data sets are not used.

This parameter is only valid in the shared-queues environment. If shared queues are enabled, the value that is specified in the QBUIFSZ= parameter is used to determine the size of the message queue buffers.

QTL= parameter for procedures

Use the QTL= parameter in procedure to specify the lower threshold percentage (1 to 99) for each message queue data set in a **non-shared-queues environment**, or the lower threshold percentage (1 to 99) for the device relative record number (DRRN) in-use count in a **shared-queues environment**. The default value is 60%.

For a non-shared-queues environment, specifies the lower threshold percentage (1 to 99) for each message queue data set. If this threshold is crossed, and if the associated exit has not been modified, a message is issued.

For a shared-queues environment, specifies the lower threshold percentage (1 to 99) for the device relative record number (DRRN) in-use count. If this threshold is crossed, and if the high threshold count was reached, a message is issued and all messages in an IWAIT state are posted.

QTU must be higher than QTL, and 0 is not valid. Either error results in the defaults being used.

QTU= parameter for procedures

Use the QTU= parameter in procedure to specify the upper threshold percentage (2 through 100) for each message queue data set in a **non-shared-queues environment**, or the upper threshold percentage (2 to 100) for the DRRN in-use count in a **shared-queues environment**. The default value is 75%.

For a non-shared-queues environment, specifies the upper threshold percentage (2 through 100) for each message queue data set. If this threshold is crossed, and the associated exit routine has not been modified, a message is issued.

For a shared-queues environment, specifies the upper threshold percentage (2 to 100) for the DRRN in-use count. If this threshold is crossed, and if the high threshold count was reached, a message is issued and all messages being retrieved from shared queues are put in an IWAIT state until the lower threshold is reached.

In a shared-queues environment, when the QTU percentage is reached for either SHMSG or LGMSG message queue buffers, IMS tries to allocate one more bitmaps (SHMSG or LGMSG, as appropriate) within the range of queue buffers defined by QBUFMAX. If successful, this reduces the percentage used for this type of message queue buffer below the QTU percentage. If one more bitmap cannot be allocated, message DFS2281I is issued and IMS then works in degraded mode until the percentage used for this type of message queue buffer drops below the QTL percentage.

RC= through RVFY= procedure parameters

The procedure parameters RC= through RVFY=, which are described in the following list, can be specified in procedures in the IMS environment.

RC= parameter for procedures

Use the RC= parameter in procedure to specify the message number for which information is to be searched.

RCF= parameter for procedures

Use the RCF= parameter in procedure to specify whether RACF is to be used for transaction authorization or sign-on authorization checking. Valid values are A, C, N, S, T, and Y. If the RCF parameter is not specified, the default is the value specified at system definition.

Changes to the value of this parameter require an IMS cold start.

A

Includes options T, C, and S.

C

Specifies that RACF is to be used for ETO terminal signon and command authorization.

N

Specifies that no signon, transaction, or command authorization is to be performed by RACF.

S

Specifies that RACF is to be used for static and IMS ETO terminal command authorization. If signon verification is not explicitly specified during IMS system definition (or with the SGN= parameter), signon verification security is set on by this specification of command authority.

T

Specifies that RACF is to be used for signon and transaction authorization.

Y

Includes options T and C.

RCFTCB= parameter for procedures

Use the RCFTCB= parameter in procedure to specify a number between 1 and 20 indicating how many RCF TCBs are defined in your system.

If you specify a null value or an invalid value, IMS uses the default of 1 RCF TCB. Increasing the number of RCF TCBs allows you to customize your system to achieve maximum parallelism and improved performance during RACF sign-on and sign-off calls.

RCLASS=*identifier* parameter for procedures

Use the RCLASS=*identifier* parameter in procedure to specify a 1- to 7-character alphanumeric subsystem identifier for the RACF resource classes for this IMS subsystem. Use this parameter to uniquely identify the resource classes for this IMS subsystem in RACF.

Specifies a 1- to 7-character alphanumeric subsystem identifier for the RACF resource classes for this IMS subsystem. Use the RCLASS= parameter to uniquely identify the resource classes for this IMS subsystem in RACF.

RACF appends the subsystem identifier to a resource class identifier to create the full name of each IMS resource class in RACF. For example, if you specify RCLASS=IMS123, the name in RACF of the IMS transaction authorization resource class for this subsystem would be "TIMS123", because the resource class identifier for IMS transaction authorization is "T". And the name of the IMS command authorization resource class for this IMS subsystem would be "CIMS123".

Defining different subsystem identifiers can be useful for restricting access to resources in one subsystem, while allowing access to those same resources in another. For example, if a production subsystem has a subsystem identifier of IMSPROD and a test subsystem has a subsystem identifier of IMSTEST, an application programmer could then be authorized to TRAN01 in the TIMSTEST transaction authorization resource class, but not to TRAN01 in the TIMSPROD transaction authorization resource class.

The RCLASS= specification in the DFSPBxxx PROCLIB member overrides the RCLASS= specification in the DFSDCxxx PROCLIB member.

RACF uses "IMS" as the default subsystem identifier for IMS subsystems.

RDMNM=*name* parameter for procedures

Use the RDMNM=*name* parameter in procedure to specify the Recovery Data Manager PROCLIB member name. If this optional parameter is not specified, the default RDM is used. If the Recovery Data Manager PROCLIB member is not found, IMS Database Recovery Facility uses default values.

RDS= parameter for procedures

Use the RDS= parameter to specify the buffer size to be used for the restart data set (IMS.RDS).

You can specify a value in the range from 1024 to 32,760. Specifying the maximum 32K buffer size value (RDS=32,760) is suitable as a general practice because it offers the best system performance and storage impact is minimal. If you do not specify a value for this parameter, IMS sets a default size of 4096 for the IMS.RDS data set.

Important: If you change the value of this parameter and then you restart the IMS system, you must ensure that either the FORMAT RS or the FORMAT ALL keyword is specified on the **/ERESTART** or **/NRESTART** command. If not, the restart can fail.

Related reference

[/ERESTART command \(Commands\)](#)

[/NRESTART command \(Commands\)](#)

READNUM= parameter for procedures

Use the READNUM= parameter in procedure to specify the number of input devices that are to be used for IMS Database Recovery Facility. The allowable range is 1 through 99. The default value is 3.

If input data resides on tape, READNUM specifies the maximum number of tape drives that can be concurrently allocated for IMS Database Recovery Facility.

RECA= parameter for procedures

Use the RECA= parameter in procedure to specify the number of receive-any buffers (1 to 500). This parameter overrides what is specified in the RECANY= parameter on the COMM macro.

If MNPS is used for XRF, the RECA= specification indicates the number of buffers for the MNPS ACB. IMS automatically allocates one additional buffer for the APPLID ACB.

RECASZ= parameter for procedures

Use the RECASZ= parameter in procedure to specify a 1- to 5-digit number indicating the size of the receive-any buffers. Valid values are from 112 to 30720.

If you specify a null or invalid value, IMS uses the value specified in the RECANY parameter of the COMM macro used in the IMS definition. If that value is 0, IMS uses a default value of 2100.

RES= parameter for procedures

Use the RES= parameter in procedure to specify whether (Y) or not (N) the PSBs or DMBs defined in system definition macros APPLCTN or DATABASE as RESIDENT should be made resident during system initialization. Valid values are Y, or N. The default is Y.

REST=*nn* parameter for procedures

Use the REST=*nn* parameter in procedure to specify a 2-digit number greater than 00 to indicate from which set of utility control statements starts processing. A specification of 00 indicates no restart.

Values 00 and 01 start with the first set. Sets of utility control statements with lower values than that specified by *nn* are not processed. A set of control statements is defined by the GO statement.

Restriction: The REST=*nn* parameter does not apply to DEDB Alter.

RGN= parameter for procedures

Use the RGN= parameter in procedure to specify the region size for this execution. For Fast Path, the default is 100K.

If TLIM is specified as a number greater than 1, the RGN symbolic parameter must be increased approximately 50K bytes to allow virtual storage overhead for handling RE-IN-STATE situations. Insufficient virtual storage specification results in an S106 abend of the IFP region.

RGSUF=*xxx* parameter for procedures

Use the RGSUF=*xxx* parameter in procedure to specify a 3-character suffix for DFSPB*xxx*.

This member contains default values for JCL EXEC statement parameters. It minimizes the number of EXEC parameter overrides needed so the EXEC parameter string does not exceed the 100 byte limit.

RMINIT= parameter for procedures

Use the RMINIT= parameter in procedure to specify a 3-character suffix for the RM initialization parameters PROCLIB member, CSLRI*xxx*. This parameter can be specified only as an execution parameter. The default suffix is 000.

RMNAME= parameter for procedures

Use the RMNAME= parameter in procedure to specify the name for the RM address space.

This is an optional 1-6 character name. If specified, it overrides the value specified in the CSLRIxxx PROCLIB member. You must specify this parameter either as an execution parameter or in the CSLRIxxx PROCLIB member. This name is used to create the RMID, which is used in RM processing. The 8-character RMID is the RMNAME followed by the characters RM. Trailing blanks in the RMNAME are deleted, and the RMID is padded with blanks. For example, if RMNAME=ABC then RMID="ABCRM".

RRS= parameter for procedures

Specifies whether (Y) or not (N) the registration and connection to z/OS Resource Recovery Services (RRS) should be made. Valid values are Y, or N. The default is N.

When using the z/OS Resource Recovery Services (RRS) feature, be aware that the optional RRS archive log stream typically generates large amounts of additional logging to the z/OS logger. If you use RRS Archive Logging, monitor it closely for system log stream performance impact.

For Fast Path capable systems, if RRS=Y is specified then the storage for Fast Path EPST blocks is always page fixed, regardless of the contents of the DFSFIXxx PROCLIB member.

RRS must be set to Yes (RRS=Y) if you use WebSphere Application Server or WebSphere Liberty Profile Server and access IMS databases with type-2 IMS Universal Database resource adapter connectivity through ODBA or ODBM. To learn more, see [IMS Universal drivers: WebSphere Application Server Liberty type-2 connections \(Communications and Connections\)](#).

RST= parameter for procedures

Use the RST= parameter in procedure to specify UCF restart. A value of 0 (no) or 1 (yes) must appear in the generated JCL statement for this parameter. Valid values are 0, or 1.

Related reading: For more information about UCF restart, see *IMS Version 15.4 Database Utilities*.

RVFY= parameter for procedures

Use the RVFY= parameter in procedure to specify whether password reverification is activated (Y) or not (N). Valid values are Y, or N. The default is N.

SAV= through SUF= procedure parameters

The procedure parameters SAV= through SUF=, which are described in the following list, can be specified in procedures in the IMS environment.

SAV= parameter for procedures

Use the SAV= parameter in procedure to specify a 1- to 3-digit number of dynamic save area sets for communication terminal I/O requests. IMS expands the number of SAPs up to 10 times this number as it needs to process the work being given to the system.

You can use the following formula for calculating the number of SAPs that your IMS system requires:

Formula for calculating the number of SAPs:

```
((# of VTAM terminals + 39) ÷ 40)
+ ((# of MSC links + 1) ÷ 2)
+ 1 (if VTAM required) + 60 (if ETO defined)
+ 4 (base ITASKs)
```

Valid values are from 1 to 999.

Note: Message DFS0769I could be issued while IMS is expanding the number of SAPs. If this message is issued, see *IMS Version 15.4 Messages and Codes, Volume 1: DFSMessages* for additional information.

SCEERUN= parameter for procedures

Use the **SCEERUN=** to specify the name of the System C Runtime Library data set, which corresponds to the **SCEERUN** parameter of the IMSGEN macro.

SCIINIT=xxx parameter for procedures

Use the **SCIINIT=xxx** parameter in procedure to specify a 3-character suffix for the SCI initialization parameters PROCLIB member, CSLSIxxx. This parameter can be specified only as an execution parameter. The default suffix is 000.

SCINAME=scimbrname parameter for procedures

Use the **SCINAME=scimbrname** parameter in procedure to specify the name for the SCI address space.

This is an optional 1- to 6-character name. If specified, it overrides the value specified in the CSLSIxxx PROCLIB member. You must specify this parameter either as an execution parameter or in the CSLSIxxx PROCLIB member.

This name is used to create the SCIID which is used in SCI processing. The 8-character SCIID is the SCINAME followed by the characters "SC". Trailing blanks in the SCINAME are deleted and the SCIID is padded with blanks. For example, if SCINAME=ABC then SCIID="ABCSC ".

SCOPE= parameter for procedures

Specifies whether intersystem sharing is to be performed. This parameter must always be specified because no default value exists. Valid values are LOCAL, GLOBAL, and NODISCON.

If **SCOPE=LOCAL** is specified, sharing is limited to intrasystem, and XCF and SLM are neither required or used. If **SCOPE=GLOBAL** or **SCOPE=NODISCON** is specified, intersystem sharing is performed, and both XCF and SLM are required.

With **NODISCON**, there is less impact on other systems when an IMS fails because z/OS is not required to perform certain recovery actions when IRLM DISCONNECTS from the group. **NODISCON** can also mean that IMS restarts more quickly after an IMS terminates normally or abnormally because it does not have to wait for IRLM to rejoin the IRLM data sharing group. Under normal situations, IRLM Disconnects from the group **ONLY** when there are no IMS systems identified to it. **NODISCON** has no affect as long as there is at least one IMS identified to the IRLM.

Sharing can be performed between up to 248 IRLMs on a single z/OS image. This can be done for pre-installation testing. In this case, **SCOPE=GLOBAL** must be specified for all IRLMs.

SGN= parameter for procedures

Use the **SGN=** parameter in procedure to specify whether the sign-on verification function is active. Valid values are F, G, M, N, Y, and Z.

F

Specifies that the MTO cannot negate the activation of the sign-on verification function.

G

Includes options F and M.

M

Specifies that a single user ID can sign on to multiple terminals. If the user structure name is different than the user ID for an IMS ETO user (DFSSGNX0 exit returned a user structure name that is not the same as the user ID), **SGN=M** must be specified for this user to be able to have multiple sign-on. **SGN=M** does not activate the sign-on verification function.

The **SGN=** parameter has ramifications when specified on the first IMS to become active in an IMSplex. The **SGN=** value specified on that first active IMS is used (and enforced) for the entire IMSplex unless overridden by a **/NRESTART** or **/ERESTART** command. For example, if the first IMS to connect to the IMSplex has single sign on specified, this particular IMSplex requires all IMS systems

that later connect to this IMSplex to also have single sign on specified. Similarly, if the first IMS to connect to the IMSplex has multiple sign on specified, this particular IMSplex requires all IMS systems that later connect to this IMSplex to also have multiple sign on specified.

If IMS systems try to join the IMSplex and they have a different value specified on the SGN= parameter, IMS issues an error message. For example, if IMSA connects to IMSplex1 first (with SGN=G) and then IMSB connects to IMSplex1 (with SGN=Z), an error message is issued.

If all the IMS systems in the IMSplex leave that IMSplex, then the first IMS to rejoin the IMSplex sets the SGN= value.

Important: Implementing multiple sign-on (SGN=M) requires a cold start of IMS.

N

Specifies that the sign-on verification function is not to be activated unless overridden by the MTO. For a cold start, this implies that signon verification security is not going to be in effect.

Y

Specifies that the sign-on verification function is to be activated unless overridden by the MTO.

Z

Includes options Y and M.

SGNGENRC= parameter for procedures

Use the **SGNGENRC=** parameter to specify whether a generic return code is returned by IMS if RACF is used to verify sign-ons to IMS from VTAM terminals and the user ID or password provided is invalid. Valid values are N and Y. The default is N.

N

If RACF verification is used for sign-ons from VTAM terminals and the user ID or password provided is invalid, RACF or IMS return codes are returned in the DFS2467I or DFS3649A message .

This is the default value.

Y

If RACF verification is used for sign-ons from VTAM terminals and the user ID or password provided is invalid, a generic return code, return code 500 ('user ID or password is invalid'), is returned in the DFS2467I or DFS3649A message instead of the actual RACF or IMS return code.

If you specify **SGNGENRC=Y**, ensure that both of the following requirements are met:

- RACF is enabled for IMS.
- The IRRSPW00 module, which is provided by RACF, is included in one of the following locations:
 - LPA
 - A library in LINKLIST

SHAREDQ=xxx parameter for procedures

Use the SHAREDQ=xxx parameter in procedure to specify a 3-character suffix for the shared queues IMS.PROCLIB member, DFSSQxxx. There is no default for this parameter, it must be explicitly specified.

For more information about the parameters to specify for the DFSSQxxx member, see [“DFSSQxxx member of the IMS PROCLIB data set”](#) on page 854.

Note: All of the parameters that are valid in the DFSSQxxx member of the IMS PROCLIB data set are valid in the DFSDFxxx member of the IMS PROCLIB data set.

If you specify values in both the DFSSQxxx member and the shared-queues section of the DFSDFxxx member, the values specified in the DFSSQxxx member of the IMS PROCLIB data set override the values specified in the DFSDFxxx member. If you specify all your shared-queues values in the DFSDFxxx member, you can delete the DFSSQxxx member.

When you specify this parameter, IMS uses the Common Queue Server (CQS) to place messages on the shared queues that reside in a coupling facility structure. If you do not specify this parameter, messages are placed on the message queue data sets.

SHMSGSZ= parameter for procedures

Use the SHMSGSZ= parameter in procedure to specify a 1- to 5-digit number that represents the length in bytes of a short message record.

The length of the short message record cannot exceed 30632 bytes. The length must also be greater than or equal to the number of bytes in one and one-half times the maximum message prefix length plus 4. If you specify a smaller value, the message size is set to the greater value between the size in the DCB LRECL and one and one-half times the maximum message prefix size plus 4. If you specify a value greater than 30632, the size is set to 30632. If the specified value is usable, it is rounded up to the nearest multiple of 4.

This parameter is only valid in the shared-queues environment. If you specify a value for SHAREDQ=, but not for SHMSGSZ=, the size of the short message record is obtained from the DCB generated for the short message queue data set. The DCBs for the message queue data sets are built during the IMS system generation process even though the data sets are not used.

Choose values for the SHMSGSZ= and the LGMSGSZ= based on the sizes of the messages that are processed by the queue manager. When determining which size message queue record to use, the queue manager calculates the size of the message prefix, subtracts that value from the size of the short message queue buffer and then doubles the remaining value. It then compares that value to the average user data length for the destination. If the remainder buffer size is greater than or equal to the average user data size, then the short message queue buffer is used. If the remainder buffer size is less than the average user data size, then the large message queue buffer is used. The length of the message prefix varies based on the IMS system options specified.

For a list of message prefix lengths see [Table 55 on page 456](#).

SIMEXIT= parameter for procedures

Use the SIMEXIT=N|Y parameter in procedure to specify whether (Y) or not (N) the Shared Printer Message Router exit routine is to be loaded by IMS.

The default is N.

The exit routine must be placed in an authorized library in the JOBLIB, STEPLIB, or LINKLIST library concatenated in front of the IMS.SDFSRESL. The name of the exit routine must be DFSSIMLO. A default exit routine is not provided.

If SIMEXIT=Y is specified, the exit routine DFSSIMLO is called when a message is queued for terminals defined with OPTIONS=SHARE on the TERMINAL macro statement.

When SIMEXIT=N is specified, which is the default, the router module assumes that /OPN is always simulated when output is enqueued for a terminal defined as OPTIONS=SHARE on the TERMINAL macro statement.

SOD= parameter for procedures

Use the SOD= parameter in procedure to specify a 1-character class for SYSOUT to be used for the spin-off main storage dump. If omitted or specified as 0, no spin-off dump is taken.

SOUT= parameter for procedures

Use the SOUT= parameter in procedure to specify the class assigned to SYSOUT DD statements. The default is A.

SPAP= parameter for procedures

This parameter is no longer used.

SPIE= parameter for procedures

Use the SPIE= parameter in procedure to specify the SPIE option. Valid values are 0, or 1.

A value of 0 or 1 must appear in the generated JCL statement for this parameter.

0

Allow your SPIE (the SPIE established by the application program), if any, to remain in effect while the application program call is being processed.

1

Negate your SPIE while the application program call is being processed. Negated SPIEs are reinstated before returning to the application program.

Under z/OS, if SPIE=1, a SPIE must be established; otherwise, system abend ABEND46D is issued.

SPM=xx parameter for procedures

Use the SPM=xx parameter in procedure to specify a 2-character suffix for the storage pool manager PROCLIB member, DFSSPMxx.

SRCH= parameter for procedures

The SRCH= parameter in procedure is the module search indicator for directed load. Valid values are 0, or 1.

0

Standard search

1

Search JPA and LPA before searching PDS

SSM= parameter for procedures

Use the SSM= parameter in procedure to specify a 1- to 4-character identifier for a member that identifies the external subsystems that IMS connects to.

When building IEBUPDTE JCL, you must generate the member name by concatenating this SSM identifier to the IMSID. You can specify the values for SSM= with alphabetic characters (A - Z), \$, #, or @, and numeric digits (0 - 9).

An SSM PROCLIB member can contain either positional-format statements in a fixed order, or keyword-format statements in a semi-fixed order.

Restriction: A single subsystem definition cannot use both positional and keyword parameters simultaneously.

Positional format

Fixed parameter format. Keywords are not allowed. Values must be entered in the following order:
ssn, lit, esmt, rtt, reo, crc.

For example,

```
V10A, SYS1, DSNMIN10, RTTDB2A, R, -
```

Keyword format

Keyword-only, and must begin with SST=. After SST=, most values can be specified in any order:

```
SST=, SSN=, LIT=, ESMT=, RTT=, REO=, CRC=, RLA=
```

For example,

```
SST=DB2,SSN=DB21,LIT=SYS1,ESMT=DSNMIN10,REO=R,CRC=-,RLA=Y
```

If COORD is specified, only SST= and SSN= may also be specified; all other keywords are ignored:

```
SST=,SSN=,COORD=
```

For example,

```
SST=DB2,SSN=DB21,LIT=SYS1,ESMT=DSNMIN10,REO=R,CRC=-
```

```
SST=DB2,CRC=-,REO=R,ESMT=DSNMIN10,LIT=SYS1,SSN=DB21
```

```
SST=MQ,SSN=SYS3,LIT=MQM3,ESMT=CSQQESMT
```

```
SST=DB2,SSN=V71A,COORD=RRS
```

All external subsystems to be accessed by any region must be defined in this member. Essentially, the member specified by the IMS procedure is a master list. Dependent region procedures (DFSMPR, IMSBATCH, IMSFP, DFSJPB, and DFSJMP) can define subset lists. Each subset list can define all, some, or none of the external subsystems defined in the IMS master list. The SSM entry in each dependent region controls that region's access to subsystems.

Specifying SSM in a dependent region procedure but not in the IMS procedure is invalid, and no connection is made.

- To allow an MPP, BMP, or IFP region to access all subsystems defined in the IMS procedure, do not code SSM. However, if preferred, the SSM entry can specify the same member as the IMS procedure.
- To allow access to selected subsystems, specify a member that defines only those subsystems a region is allowed to access. For example, if the IMS procedure member defines subsystems A, B, and C, but a region is only to access A and C, the region's SSM should specify a member defining only A and C. Thus, the SSM member is a subset of the IMS procedure member.
- To prevent this region from accessing any subsystem, specify a member that contains no entries.
- To enable the external subsystem attach facility (ESAF) for a JMP or JBP region, the SSM= parameter must be specified on the DFSJMP procedure or DFSJBP procedure. The SSM= value can be the same value that is specified on the SSM= parameter for the IMS procedure.

STIMER= parameter for procedures

Use the STIMER= parameter in procedure to specify the processor time statistics to be gathered. Valid values are 0, 1 and 2. The default is 2.

Important: The following description applies to message-driven programs only.

0

No processor time statistics are to be gathered. No STIMER/TTIMER sequence is issued.

1

No DL/I processor time is to be included in the processor time statistics. An STIMER/TTIMER sequence is issued once for each program invocation and once for each DL/I call.

Specify this value for a BMP when you want to gather statistics. Specifying STIMER=1 for a BMP or IFP is like specifying STIMER=2 for an MPP. The overhead associated with it is a STIMER macro, a TTIMER macro, a load instruction, and a subtract register instruction per BMP execution.

2

If the LSO=S region startup parameter has been selected, processor time statistics include time durations for:

- Application program time

- DL/I processing time
- CPU time for ESAF users such as Db2 for z/OS that continue to process under the TCB of the dependent region. If Db2 for z/OS switches to another TCB, which is the case with parallelism, logging, and prefetch, this time is not included.

One STIMER/TTIMER sequence is issued for each program invocation. This is the default.

If you use the IMS timing services STIMER=1 or STIMER=2, you should ensure that your application programs do not use or invoke SVC2E or SVC2F (STIMER or TTIMER). Specifying STIMER=2 is invalid for an IFP region. If these services are invoked, they negate the function of controlling application programming loops, and invalid time statistics might be gathered. Additionally, ABENDU240 might occur. You should also be aware that the LSO option you select affects the meaning of the processor time statistics. If LSO= is specified, most DL/I processing time is not included in the statistics.

SUF=*n* parameter for procedures

Use the SUF=*n* parameter in procedure to specify the 1-character suffix for the control program name. This suffix allows multiple copies of the IMS nucleus to reside on IMS.SDFSRESL.

This parameter cannot be changed at emergency restart.

SVC2= through TLIM= procedure parameters

The procedure parameters SVC2= through TLIM=, which are described in the following list, can be specified in procedures in the IMS environment.

SVC2= parameter for procedures

Specifies the Type 2 SVC number that IMS uses.

You can specify a value in the range 200 - 255 for this parameter in one of the following locations. If you do not specify this parameter, IMS uses a default value of 254.

Important: If you use the Open Database Access (ODBA) interface or the database resource adapter (DRA) and you do not want to use the default value of 254 for the type 2 SVC number, you can define the number only by using the DFSIDEF macro of the DFSIDEF0 module.

- In the DFSPBxxx member of the IMS PROCLIB data set
- In JCL
- On the DFSIDEF macro of the DFSIDEF0 module. If you specify the type 2 SVC number on the DFSIDEF macro, assemble and bind the DFSIDEF0 module into the IMS execution library.

The value that is specified in the DFSPBxxx member or in JCL overrides the value that is specified on the DFSIDEF macro.

SVSODR= parameter for procedures

Use the SVSODR= parameter in procedure to specify options for processing shared VSO areas at a remote site. This parameter is optional. Valid values are NONE, AUTO, DRRS, and WTOR. The default is NONE.

The options take effect during an emergency restart or first area open after an emergency restart when IMS connects to and creates a structure for a shared VSO area.

NONE

Specifies that processing is unchanged from existing shared VSO emergency restart processing. This is the default.

AUTO

Specifies that during emergency restart or first area open after an emergency restart, if IMS connects to a new structure for a shared VSO area, that area is automatically marked as recovery needed in the RECON data set. If the connection is made to a failed persistent structure, processing continues as normal.

DRRS

This option is specified for a system that is to be restarted at the disaster recovery remote site.

Typically, when an emergency restart occurs at a remote site, the connection creates a structure and the areas need to be marked as recovery needed in the RECON data set.

However, when the DRRS option is specified, IMS recognizes that the emergency restart is at a remote site and processes accordingly. During area-open processing for a shared VSO area, IMS does not attempt to connect to shared VSO structures. The areas are marked as recovery needed in DBRC. Specifying this option saves the overhead of doing a connect and then a disconnect for each shared VSO area.

WTOR

Gives the user the option of marking shared VSO areas as recovery needed. During an emergency restart or first area open after an emergency restart, IMS connects to a shared VSO structure. If the connection creates a structure, a WTOR is generated. The prompt then gives the user the option of continuing to process with the new structure or marking the area as recovery needed. Based on the reply to the WTOR, IMS processes accordingly. A WTOR is issued for each shared VSO area that is opened during an emergency restart or first area open after an emergency restart when the connection creates a structure.

The WTOR message is:

```
DFS2853A A NEW STRUCTURE WAS CREATED FOR AREA AAAAAAAA.  
REPLY 'C' TO CONTINUE OR 'R' TO RECOVER
```

Note: These options can also be specified at a local site.

SWAP= parameter for procedures

Use the SWAP= parameter in procedure to specify whether to make address space swappable (Y) or non-swappable (N). The default is Y.

If you are using DBRC, you might want to choose option N because of the possibility of being swapped out while holding the reserve on RECON.

If you are using IRLM for block-level data sharing, the SWAP parameter has no effect. If you specify IRLM=Y, a batch job is always made nonswappable to prevent the job from obtaining locks for resources and then being swapped out.

SYS= parameter for procedures

Use the SYS= parameter in procedure to specify an optional second-level dsname qualifier for those data sets designated as "mandatory shared" in an XRF complex.

When specified, the operand must be enclosed in single quotation marks and must include a trailing period.

Example: SYS='IMSA.'

SYSID= parameter for procedures

Use the SYSID= parameter in procedure to specify the SYSID of the subsystem that failed with the given abend code.

SYS1= parameter for procedures

Use the SYS1= parameter in procedure to specify an optional second-level dsname qualifier for those data sets designated as "mandatory replicate" in an XRF complex. When specified, the operand must be enclosed in single quotation marks and must include a trailing period.

Example: SYS1='IMSA.'

SYS2= parameter for procedures

Use the SYS2= parameter in procedure to specify an optional second-level dsname qualifier for those data sets designated as "optional replicate" in an XRF complex. When specified, the operand must be enclosed in single quotation marks and must include a trailing period.

Example: SYS2='IMSA.'

T= parameter for procedures

Use the T= parameter in procedure to specify the abend type. Valid values are S for system abends and U for user abends.

TCORACF= parameter for procedures

Use the TCORACF= parameter in procedure to specify whether (Y) or not (N) RACF should be called to perform an authorization check of commands from a TCO script. The default is N.

Because the TCORACF specification is not included in a checkpoint record, you can change the TCORACF value each time IMS is initialized.

TEST= parameter for procedures

Use the TEST= parameter in procedure to specify whether (1) or not (0) the addresses in your call list should be checked for validity. Valid values are 0, or 1.

A value of 0 or 1 must appear in the generated JCL statement for this parameter. An address is invalid if it is either lower than the lowest address not in the z/OS nucleus or higher than the highest address in virtual storage of the machine.

TLIM=*nn* parameter for procedures

Use the TLIM=*nn* parameter in procedure to specify a 2-digit termination limit option with a decimal number between 01 and 99.

When the number of application program abends reaches this limit, the message region is automatically terminated. The accumulated number of abends for a region is increased only if the transaction is not requeued.

TLIM is not incremented in the case of a pseudoabend. This allows z/OS to print the accumulated SYSOUT data sets.

TLIM is not incremented in the case of an abend U0474 for an MPP.

The TLIM default for an IFP region is 01. For all other regions, the default is 00. If 00 is specified, no limit on program abends is set, and the message region is not automatically terminated.

For an application defined as PGMTYPE=BATCH in the APPLCTN macro statement, the optional parameter is ignored if specified.

TRACE= through YEAR4= procedure parameters

The procedure parameters TRACE= through YEAR4=, which are described in the following list, can be specified in procedures in the IMS environment.

TRACE= parameter for procedures

Use the TRACE= parameter in procedure to specify whether the IRLM is to turn on traces. Tracing is initialized at IRLM startup. Valid values are YES, and NO. The default is TRACE=NO.

NO

Turns off the high activity traces in IRLM. However, IRLM always keeps the low-activity subtraces on by default.

YES

Turns on all internal traces in IRLM.

z/OS TRACE CT commands can be used to turn on or off individual IRLM traces, except the RQH, EXP, RLE, INT traces, which are always on.

TRN= parameter for procedures

Use the TRN= parameter in procedure to specify whether transaction authorization checking is to be performed. Valid values are F, N, and Y.

If sign-on verification security is not explicitly specified during IMS system definition or with the SGN= parameter, it is set on by the specification of transaction authorization.

F

Specifies that the MTO cannot negate transaction authorization checking when issuing the /**NRESTART** command.

N

Specifies that the MTO can optionally enable transaction authorization checking by specifically requesting transaction authorization checking on the /**NRESTART** command.

Y

Specifies that the MTO can optionally override transaction authorization checking by specifically requesting no transaction authorization checking on the /**NRESTART** command.

TSR= parameter for procedures

Use the TSR= parameter in procedure to specify the chosen time stamp representation. Valid values are U, and L. The default is L.

U

The time stamp extension to the I/O PCB contains UTC.

L

The time stamp extension to the I/O PCB contains local time. The default is L extension to the I/O PCB. If you specify L, local time becomes the date extension to the I/O PCB.

UHASH= parameter for procedures

This parameter is ignored. DBFLHSH0 is always used as the Fast Path user-hashing module.

UHTS= parameter for procedures

Use the UHTS= parameter in procedure to specify a 1- to 5-digit number of user (SPQB) hash table slots. Valid values are 0 - 32767. The default is 256. If you specify a null or invalid value, 256 is assumed.

USERMSG= parameter for procedures

Use the USERMSG=N|Y parameter in procedure to specify whether (Y) or not (N) the user-supplied user message tables module DFSCMTU0 is to be loaded by IMS.

The default is N.

The user message tables module must be placed in an authorized library in the JOBLIB, STEPLIB, or LINKLIST library concatenated in front of the IMS.SDFSRESL.

USERVAR=*username* parameter for procedures

Use the USERVAR=*username* parameter in procedure to specify the user name for the IMS active subsystem. It is optional.

For an Extended Recovery Facility (XRF)-capable system, OTMA uses USERVAR as the IMS XCF (z/OS cross-system coupling facility) member name. The USERVAR= parameter overrides the USERVAR specified in the DFSHSBxx member of the IMS PROCLIB data set.

(For IMS systems without XRF, OTMA uses the OTMANM= parameter as the IMS XCF member name. If OTMANM= is not specified, OTMA uses the non-APPC VTAM LU name (APPLID1) as the member name.)

When MNPS=*name* is specified, the USERVAR specification is ignored, and IMS uses MNPS for XRF terminal switching.

VALCK= parameter for procedures

Use the VALCK= parameter in procedure to specify the validity-check option. Valid values are 0, and 1. The default is 0.

0

Do not check the validity of addresses in the user's call list. This is the default.

1

Check the validity of the addresses in the user's call list.

An address is invalid if it is either lower than the lowest address not in the z/OS nucleus or higher than the highest address in virtual storage.

VAUT= parameter for procedures

Use the VAUT= parameter in procedure to specify whether (1) or not (0) IMS is to use the VTAM authorized path facility. Valid values are 0, and 1.

VFREE= parameter for procedures

Virtual Fetch is no longer supported by the operating system. This keyword, if specified, is ignored by IMS. However, do not remove the comma from the procedure, because this parameter is positional.

VSFX= parameter for procedures

Virtual Fetch is no longer supported by the operating system. This keyword, if specified, is ignored by IMS. However, do not remove the comma from the procedure, because this parameter is positional.

VSPEC= parameter for procedures

Use the VSPEC= parameter in procedure to specify a 2-character suffix for DFSVSMxx, the IMS.PROCLIB member that contains control statements. The default is 00. The default member in IMS.PROCLIB is DFSVSM00.

Control statements in DFSVSMxx define the following:

- Size and number of buffers in a subpool
- Number and use of local shared resource pools
- Whether sequential buffering is to be used
- Various performance and trace options
- DASD logging data set requirements
- Whether dynamic allocation for IMS batch is to be used
- Coupling facility structure names for sysplex data sharing

The VSPEC= parameter performs the same function in an IMS online system that the DFSVSAMP DD statement performs in a batch system. For more information, see [“DFSVMxx member of the IMS PROCLIB data set”](#) on page 857.

WKAP= parameter for procedures

Use the WKAP= parameter in procedure to specify the amount of subpool 231 storage to be allocated to the work area pool. The default is 5K.

The value can be specified as 1- to 6-numeric characters or 1- to 5-numeric characters followed by K (kilobyte), M (megabyte), or G (gigabyte). If K, M, or G is not specified, K is the default. The maximum value that can be specified is 2G-1. If the value specified exceeds 2G-1 the default is 2G-1. The value entered is rounded up to the nearest 4K page boundary.

The WKAP pool size cannot be specified at system definition.

XPLINK= parameter for procedures

This parameter is obsolete. If it is specified, it is ignored. Valid values are Y and N. The default is N.

For Java dependent regions, this parameter is internally set to XPLINK=Y, which means that the JVM LE enclave is initialized with XPLINK(ON).

YEAR4= parameter for procedures

Use the YEAR4= parameter in procedure to specify whether the year is displayed as 4 digits in the time stamp as a result of the display command. Valid values are Y and N. The default is N.

N

Displays 2 digits.

Y

Displays 4 digits.

DD statements for IMS procedures

The IMS-supplied procedures can contain various DD statements.

DD statement descriptions

The following list contains a description of all the DD statements that can be used by the procedures that are supplied for IMS.

DFCTL DD

Defines a data set that contains control statements for OSAM Sequential Buffering (SB) and Fast Path High-Speed Sequential Processing (HSSP). The DFCTL DD statement can be optionally used in the JCL of the IMS batch or IMS dependent online regions. The statement must point to a sequential data set or a partitioned data set member. The data set record format must be F, FB, or FBS.

Use sequential buffering control statements to:

- Specify I/O operations that require sequential buffering (SB).
- Capture internal calls to the SB buffer handler.
- Take a snapshot of SB control blocks.
- Perform an SB buffer handler self-check.

For more information, see [“Specifying sequential buffering control statements”](#) on page 211.

Use HSSP control statements to:

- Set up the environment in which you process a selected PCB with HSSP.
- Create an image copy of a designated DEDB area.

- Suppress index maintenance for any DEDB databases with a secondary index for a specific PSB.
- Restrict access of a specific HSSP or non-HSSP application program to only designated DEDB areas.
- Allocate the utility private buffers in 64-bit common storage. By default, the buffers are allocated in 31-bit extended common storage (ECSA).

To learn more, see [“Using high-speed sequential processing control statements”](#) on page 212.

DFSDB2AF DD

Points to the Db2 for z/OS libraries that contain modules used by Db2 Resource Recovery Services attachment facility (RRSAF). Use this DD statement in the DFSJMP or DFSJBP procedure of a JMP or JBP that accesses Db2 for z/OS databases.

An example of a DFSDB2AF DD statement is as follows:

```
//DFSDB2AF DD DISP=SHR,DSN=IMS.SDFSRESL
//          DD DISP=SHR,DSN=DSNxxx.DSNLOAD
//          DD DISP=SHR,DSN=DSNyyy.DSNLOAD
```

DFSESL DD

Points to the external subsystem libraries that contain modules used by External Subsystem Attach Facility (ESAF).

The DFSESL DD statement must be included in the procedures for IFP, MPP, BMP, JMP, or JBP regions that access Db2 for z/OS databases using ESAF. The control region must also have access to the ESS libraries. You can use the DFSESL DD statement or you can concatenate the libraries with the JOBLIB/STEPLIB libraries in the control region instead of using the DD statement. The external subsystem libraries must follow IMS.SDFSRESL.

The following is an example of a DFSESL DD statement:

```
//DFSESL DD DISP=SHR,DSN=IMS.SDFSRESL
//          DD DISP=SHR,DSN=DSNxxx.DSNLOAD
//          DD DISP=SHR,DSN=DSNyyy.DSNLOAD
```

DFSHALDB DD

The data set can be either a member of a PDS, a PS, or instream. The data set attributes must be LRECL=80 and RECFM=FB. The contents of this data set should be the HALDB control statements that restrict processing to a single partition.

DFSOLPnn DD

Defines the primary online DASD log data set, where *nn* can be any numeric value. You can specify between 3 and 100 primary DASD data sets. The block size for the online log data sets must be a minimum of 6 KB and a multiple of 2048 bytes.

For more information about allocating data sets, see [Allocating log data sets \(System Definition\)](#).

DFSOLSnn DD

Defines the optional secondary online DASD log data sets, where *nn* can be any numeric value. You can specify between 3 and 100 secondary DASD data sets. The block size for the online log data sets must be a minimum of 6 KB and a multiple of 2048 bytes. These statements are required only if dual logging is requested. Suffixes must be consistent with the primary log data sets.

For more information about allocating data sets, see [Allocating log data sets \(System Definition\)](#).

DFSRESLB DD

Points to an authorized library that contains the IMS SVC modules. For IMS batch, IMS.SDFSRESL and any data set that is concatenated to it on the DFSRESLB DD statement must be authorized through the Authorized Program Facility (APF).

DFSSTAT DD

Defines a data set describing DB call and buffering activity during an application's execution. The reports are written when the application terminates. If you are interested in receiving //DFSSTAT reports, include a //DFSSTAT DD statement in this procedure. For example: //DFSSTAT DD SYSOUT=A

For more information about interpreting //DFSSTAT reports, see *IMS Version 15.4 System Utilities*.

DFSTCF DD

Defines the data set specified if the time-controlled operation function is used.

DFSURWF1 DD

Defines the work data set used to resolve logical or secondary index relationships. This DD statement is required if you are running a DL/I batch processing program and PROCOPT=L is specified in the program's PSB to load a database with one or more secondary indexes.

The DFSURWF1 work data set is used as input to the Prefix Resolution utility. This data set can reside on a tape or a direct-access device. Specify DISP=KEEP since this data set might be involved in restart processing. You must specify RECFM=VB and BLKSIZE on this DD statement. A value of LRECL=900 is recommended, but a smaller value (as small as 300) can be used if no secondary indexes are present.

DFSVSAMP DD

Defines the following:

- Size and number of buffers in a subpool
- Number and use of local shared resource pools
- Whether sequential buffering is to be used
- Various performance and trace options
- DASD logging data set requirements
- Whether dynamic allocation for IMS batch is to be used
- Coupling facility structure names for sysplex data sharing
- Caching option for the OSAM subpools.

The DFSVSAMP DD statement performs the same function in an IMS batch system that the DFSVSMxx DD statement performs in an online system. In a batch system, the control statements defining the preceding options are in a data set with the ddname of DFSVSAMP; in an online system, the control statements are in a member of the IMS.PROCLIB data set with the member name of DFSVSMxx.

DFSWADS n DD

Defines the required write-ahead data sets, where n can be a number from zero to nine. If dual logging to the WADS is requested, at least two WADS data sets must be provided. If an I/O error occurs on the current WADS, the next WADS is used.

Dual WADS logging provides backup on a read error while terminating the OLDS from the WADS. The primary and secondary WADS contain the same data. Single or dual WADS logging is determined from an execution-time parameter you specify. Regardless of whether dual logging is selected, as many as 10 WADS DD statements can be included. The extra data sets serve as spares on write errors. When a write error occurs, write-ahead logging continues whether single mode or dual mode is selected. One of the spare data sets is substituted for the one with the error. When required WADSs are unavailable because of I/O errors, IMS issues a warning message and continues processing in a degraded mode, truncating OLDS buffers for LWA. When switching to a new WADS after a write error, the current online log buffer is truncated and written to the OLDS, making obsolete all data currently in the WADS.

FORMATA DD and FORMATB DD

Points to IMS.FORMAT A and IMS.FORMAT B, which contain online MFS definitions to be used as the format library by the online system. They are required by MFS-supported terminals.

IMS limits the number of data sets that can be concatenated for MFS format libraries, IMS.FORMAT A and IMS.FORMAT B, to 16. All the concatenations must have like attributes.

FPTRACE DD

Defines the destination for the Fast Path trace output. Activate the trace with the DD statement in the procedure and the following command:

```
/TRACE SET ON TABLE FAST
```

IEFRDER DD

Defines the primary system log data sets. If DASD instead of tape is used for logging, substitute the appropriate DD statements. IEFRDER and IEFRDER2 can be a combination of tape and DASD. This statement is not required in DB/DC or DBCTL environments if the job does not declare database-update intent.

For more information about allocating data sets, see [Allocating log data sets \(System Definition\)](#).

IEFRDER2 DD

Defines the secondary system log data sets. This statement is included only when dual system log data sets are used. If DASD is used for logging instead of tape, substitute the appropriate DD statements. IEFRDER and IEFRDER2 can be a combination of tape and DASD.

For more information about allocating data sets, see [Allocating log data sets \(System Definition\)](#).

IMS DD

Add an IMS DD statement for IMS.PSBLIB, concatenated with IMS.DBDLIB, if GSAM or GLOBAL databases are accessed by the batch application. The statements are:

```
//IMS DD DSN=IMS.PSBLIB,DISP=SHR
// DD DSN=IMS.DBDLIB,DISP=SHR
```

The PSB for the batch application program must be contained in the IMS.PSBLIB, and the DBDs for the GSAM or GLOBAL databases referenced by the PSB must be contained in the IMS.DBDLIB.

IMSACB DD

Points to a partitioned data set that contains the output from ACBGEN. The IMSACB DD applies to the DBBBATCH procedure. The IMSACB DD should only be used if online change is not used. To avoid user error, do not use the IMSACB DD if local online change or global online change is enabled. If local online change is enabled, use the MODSTAT DD instead. If global online change is enabled, use the OLCSTAT DD instead.

IMSACBA DD and IMSACBB DD

Point to partitioned data sets containing the output from ACBGEN. Two statements are needed for online change. If any DOPT PSBs exist for an online system, they must reside in any concatenation other than the first. If OLCSTAT is omitted or cannot be accessed, the MODSTAT DD is used, if defined. If OLCSTAT and MODSTAT are omitted or cannot be used, IMSACB DD is used.

If you are using the DFSMDA member with TYPE=IMSACBA and TYPE=IMSACBB to dynamically allocate the IMS IMSACBA and IMSACBB library data sets, remove the IMSACBA and IMSACBB DD statements from your FDR, DBC, DCC, DLISAS, and IMS procedures.

IMSDALIB DD

Defines the non-authorized partitioned data set (PDS) in which members to be dynamically allocated can be stored. Examples include RECON definitions, database definitions, and anything that is in a DFSMDA member.

As implied by the absence of IMSDALIB from the list of valid DD statements in [“DLIBATCH procedure” on page 628](#) (for the DLIBATCH procedure) and [“DBBBATCH procedure” on page 601](#) (for the DBBBATCH procedure), IMSDALIB is not supported in batch mode.

IMSIRD DD

Defines the data set that submits the modified start-up JCL for a dependent region to the JES internal reader.

IMSLOGR

Defines the input log data set for extended restart. This statement is required if an application program is performing an XRST call. Any program that issues symbolic checkpoint calls must also issue the XRST call and therefore requires the IMSLOGR DD statement.

For more information about allocating data sets, see [Allocating log data sets \(System Definition\)](#).

IMSMON DD

Describes the recording device that the IMS monitor uses.

IMSRDS DD

Defines the first restart data set; this data set contains information required for recovery, including the checkpoint ID table needed for restarting IMS. This data set does not contain any log records.

IMSRDS2 DD

Defines the second restart data set. It is used only in an XRF system. This data set is identical in function to IMSRDS DD.

IMSTFMTA DD and IMSTFMTB DD

Point to IMS.TFORMAT, which contains the online MFS descriptors for test mode online execution. These DD statements consist of IMS.TFORMAT, concatenated in front of IMS.FORMATA and IMS.TFORMAT, concatenated in front of IMS.FORMATB. If you change MFS formats online, the two DD statements might point to this single TFORMAT data set, or the DD statements might point to two separate TFORMAT data sets.

INPARMS DD

INPARMS is a DD statement used by the IMS abend search and notification program, DFSIASNP. It points to a data set member created by the setup panel that contains keywords and their corresponding values. The keywords are used in email and text messages, where a parser substitutes corresponding values in place of the keywords inside the email and text messages.

JAVAOUT DD and JAVAERR DD

Point to z/OS UNIX System Services file system files that Java opens and assigns to `stdout` and `stderr`. All `System.out.print()` calls from the Java application are directed to the UNIX System Services file system file that is specified in the JAVAOUT DD statement. All `System.err.print()` output from the Java application is directed to the UNIX System Services file system file that is specified in the JAVAERR DD statement.

Recommendation: Specify these DD statements if you want to take advantage of the function that they offer. If you do not specify the JAVAOUT DD or the JAVAERR DD statements, `System.out.print()` and `System.err.print()` calls in the Java application do not generate any output.

JCLOUT DD

Defines a data set where output produced by a GENJCL command is to be written.

JCLPDS DD

Defines a partitioned data set that contains the skeletal JCL execution and default members used by the GENJCL commands.

LGMSG DD

Points to the normal long message data set. If a batch only execution is planned, you do not need the message queue data sets. The Queue Manager Concurrent I/O provides a facility for the IMS customer to provide multiple Normal short and long message queue data sets. This facility is optional and is started by the IMS customer providing from 1 to 10 DD statements for the Normal short and long message queues data sets.

The current implementation of the Normal short and long message queues allows only one DD statement for each.

LGMSGL DD

Points to the local long message data set. This statement is used only in an XRF complex.

MODBLKSA DD

Points to IMS.MODBLKSA, which contains the system definition output to be brought online using a /MODIFY command when IMS.MODBLKSB is actively being used by the control region. MODBLKSA must be authorized by APF.

MODBLKSB DD

Points to IMS.MODBLKSB, which contains the system definition output to be brought online using a /MODIFY command when IMS.MODBLKSA is actively being used by the control region. MODSBLKB must be authorized by APF.

MODSTAT DD

Points to IMS.MODSTAT, the modify status data set. The MODSTAT data set contains online change status for an IMS that has local online change enabled. The MODSTAT data set keeps track of the DD names of libraries that are active:

- ACBLIBA or ACBLIBB
- FORMATA or FORMATB
- MODBLKSA or MODBLKSB

The MODSTAT DD applies to the IMS procedure and the DBBBATCH procedure. The MODSTAT DD is not needed in the IMS procedure when global online change is enabled.

If the OLCSTAT DD is omitted or the OLCSTAT data set cannot be accessed, the MODSTAT DD (if defined) determines which ddname to use. If both the OLCSTAT DD and the MODSTAT DD are omitted or the OLCSTAT and MODSTAT data sets cannot be accessed, the IMSACB DD is used.

For the IMS procedure, the ddnames you can use are ACBLIBA (or ACBLIBB), FORMATA (or FORMATB), and MODBLKSA (or MODBLKSB). For the DBBBATCH procedure, the ddname to use is IMSACBA or IMSACBB.

MODSTAT2 DD

Points to IMS.MODSTAT2, which indicates the active or inactive data sets that the IMS online system should use during initialization. This statement is used only in an XRF system.

The MODSTAT2 data set, when used for online changes, is used only for local online change. Global online change (in an IMSplex) uses the OLCSTAT data set.

MSDBCP1 DD and MSDBCP2 DD

Defines the first pair of MSDB checkpoint data sets. IMS alternates between the two when taking an MSDB checkpoint. During an /NRE, /ERE, or IMS procedure, the most current MSDB is determined, and the MSDBs are loaded from that data set (unless the MSDBLOAD keyword is specified during warm start).

MSDBCP3 DD and MSDBCP4 DD

Defines the second pair of MSDB checkpoint data sets. Used only in an XRF environment, these data sets are identical in function to MSDBCP1 and MSDBCP2. In an XRF environment, you must specify all four data sets because both the active and the alternate subsystem each require two. Any two of the four can contain the latest MSDB checkpoint. Although an active subsystem can select the data set containing the latest MSDB checkpoint, the alternate subsystem must select the two data sets not used by the active.

MSDBDUMP DD

Defines a data set that contains a dump of all MSDBs. This data set specifies where to dump the MSDBs when a /DBD DB MSDB command is entered. Successive executions of the command cause the previous contents to be overlaid.

MSDBINIT DD

Defines a data set that contains unloaded or reconstructed MSDBs. This data set specifies where to start the initial load of the MSDBs during all cold starts and during a normal restart if the MSDBLOAD parameter is specified for the /NRESTART command. It is produced by running the MSDB Dump Recovery or MSDB Maintenance utility. MSDBINIT can contain one, several, or all MSDBs defined.

OLCSTAT DD

Points to IMS.OLCSTAT, the online change status data set. The OLCSTAT data set contains online change status for an IMSplex that has global online change enabled. The OLCSTAT data set keeps track of the ddnames of libraries that are active:

- ACBLIBA or ACBLIBB
- FORMATA or FORMATB
- MODBLKSA or MODBLKSB

The OLCSTAT DD applies to the DBBBATCH procedure.

If the OLCSTAT data set is defined, it determines whether to use the IMSACBA or IMSACBB DD name. The OLCSTAT data set name is selected from either:

- The OLCSTAT DD statement that is coded in the JCL.
- The dynamic allocation MDA member, if either the OLCSTAT DD statement is omitted, or the data set from the OLCSTAT DD cannot be accessed.

If the MODSTAT DD statement is defined, it determines whether to use the IMSACBA or IMSACBB DD name only when both of the following are true:

- The OLCSTAT DD statement is omitted.
- No dynamic allocation MDA member is defined for the OLCSTAT data set.

If both the MODSTAT and OLCSTAT DD statements are omitted, the IMSACB DD is used. If either the OLCSTAT DD statement or the MDA member exists, and the OLCSTAT data set cannot be accessed, the DBB batch job fails with an abend U0821.

PRINTDD DD

Defines the output data set for the test program, including displays of control blocks using the SNAP call. It must conform to the z/OS SNAP data set requirement.

PROCLIB DD

Points to IMS.PROCLIB, which contains all IMS-generated cataloged procedures, jobs, and control statements.

QBLKS DD

Points to the normal queue blocks message data set. If a batch-only execution is planned, you do not need the message queue data sets.

QBLKSL DD

Points to the local queue blocks message data set. This statement is used only in an XRF complex.

RECON n DD

Defines the DBRC RECON data sets, where n is 1, 2, or 3. Add RECON DD statements if DBRC is being used. If dynamic allocation is being used, the DD statements are not necessary. The names of these data sets must be consistent with all subsystems that share the RECON data set.

Related reading: For more information about creating a RECON data set, see *IMS Version 15.4 System Administration*.

SHMSG DD

Points to the normal short message data set. If a batch-only execution is planned, you do not need the message queue data sets.

SHMSG L DD

Points to the local short message data set. This statement is used only in an XRF complex.

STDENV DD

Defines the input files, partitioned data sets (PDS), or physical sequential (PS) data sets that contain the IMS dependent region environment variables, parameters, and options needed to start the Java virtual machine (JVM). Environment variables, parameters, and options are specified using z/OS shell script syntax. Data sets or files concatenated in the STDENV DD statement are read in the order specified.

Important: When you use the STDENV DD statement, the IMS dependent region ignores the DFSJVM EV and DFSJVM MS members of the IMS PROCLIB data set.

When the STDENV DD statement is present, you can specify the variable **JZOS_OUTPUT_ENCODING** to set the code page that is used to convert the raw bytes for `stdout` and `stderr`. If no code page is provided in `JZOS_OUTPUT_ENCODING`, the default code page in the current locale is used for `stdout` and `stderr`.

Use the variable **JZOS_ENABLE_OUTPUT_TRANSCODING** to enable or disable the code page that is specified in `JZOS_OUTPUT_ENCODING`. The encoding option is enabled by default. If **JZOS_ENABLE_OUTPUT_TRANSCODING** is set to false, then the code page that is specified in `JZOS_OUTPUT_ENCODING` is ignored and raw bytes are written to `stdout` and `stderr`.

The classpath length under the STDENV DD statement can be up to 150K.

To learn more about shell scripts and additional supported variables, see [STDENV shell scripting \(System Definition\)](#).

STDIN DD

Points to z/OS UNIX System Services file system files that Java opens and assigns to `stdin`. `System.in.read()` reads from the UNIX System Services file system file that is specified in STDIN. For example:

```
//STDIN DD PATH=/tmp/stdin,DISP=SHR
```

STEPLIB DD

Points to IMS.SDFSRESL, which contains the IMS nucleus and required action modules. If STEPLIB is unauthorized because of having unauthorized libraries concatenated to IMS.SDFSRESL, a DFSRESLB DD statement must be included. The STEPLIB statement need not be authorized for IMS batch.

SYSABEND DD

Defines a dump data set. If both a SYSABEND DD statement and a SYSUDUMP DD statement are used, the last occurrence is used to define the dump.

SYSHALDB DD

Contains a report of all card images of the HALDB control statements with corresponding reasons for either accepting or rejecting the control statements.

SYSIN DD

Defines the control statement input data set.

SYSLIB DD

Points to the libraries that contain the other modules needed for the final executable module.

SYSLIN DD

Defines the destination of the output from the compiler.

SYSMOD DD

Defines the destination of the output for the binder.

SYSPRINT DD

Defines the output data set for control messages, statistics and reports produced by a utility.

SYSTSPRT DD

Defines the output data set for TSO Parse. The data set contains all TSO Parse error messages, such as errors in parsing the DFSRSRxx PROCLIB member. This DD statement is optional and is not generated by IMS.

SYSUDUMP DD

Defines a dump data set. If both a SYSABEND DD statement and a SYSUDUMP DD statement are used, the last occurrence is used to define the dump.

SYSUTn DD

Is a temporary work data set used by the compiler, where *n* is 1, 2, 3, or 4. This data set must reside on DASD.

CQS startup procedure

Use the CQS startup procedure to dynamically override the settings in the CQS initialization parameters member of the IMS PROCLIB data set (CQSIPxxx).

You can start CQS as a started procedure or with JCL. The started procedure JCL for CQS can execute either the CQSINIT0 or the BPEINI00 program.

A sample startup procedure called CQS can be found in the IMS PROCLIB data set. When using CQSINIT0, there is no change to the sample procedure shown in [“Sample Common Queue Server startup procedure using CQSINIT0”](#) on page 594.

JCL

The JCL for the CQS procedure using CQSINIT0 is shown in [“Sample Common Queue Server startup procedure using CQSINIT0”](#) on page 594.

Note: Make sure to use a sufficient value for RGN=. Using a value that is too small can impact IMS availability and response times. It is suggested that you use an initial value of 300M, which you can adjust higher or lower after analyzing information provided in the JES2 step termination message IEF374I. That message includes the fields SMF3OURB and SMF30EUR, which are prefixed by, respectively, the labels VIRT and EXT.

When using BPEINI00, use the same procedure shown in [“Sample Common Queue Server startup procedure using CQSINIT0”](#) on page 594, but change the EXEC statement so that PGM=BPEINI00 is specified. You must also add the BPEINIT=CSQINI00 parameter, which identifies the CQS BPE initialization parameters module. A sample startup procedure using BPEINI00 is shown in [“Sample Common Queue Server startup procedure using BPEINI00”](#) on page 595.

Note: Make sure to use a sufficient value for RGN=. Using a value that is too small can impact IMS availability and response times. It is suggested that you use an initial value of 300M, which you can adjust higher or lower after analyzing information provided in the JES2 step termination message IEF374I. That message includes the fields SMF3OURB and SMF30EUR, which are prefixed by, respectively, the labels VIRT and EXT.

Usage

[Figure 53 on page 592](#) shows the general relationship between execution parameters and members of the IMS PROCLIB data set. In the figure, CQSSL001 and CQSSL002 contain structure definition parameters that are unique to each CQS. CQSSG00A contains the structure definition parameters that are shared by all CQS address spaces connected to the shared queues.

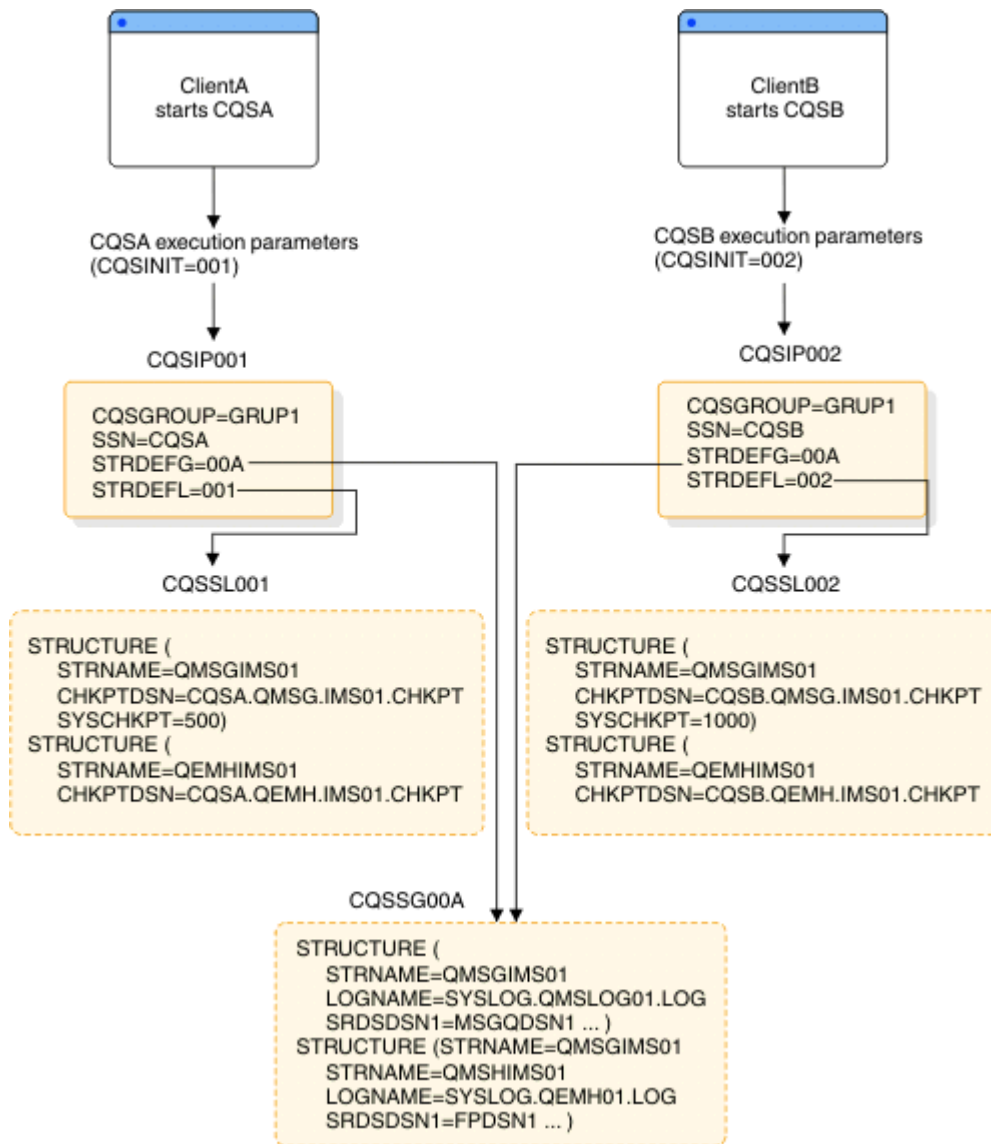

Figure 53. Specifying IMS and CQS parameters

Parameters

You can specify the following execution parameters on the CQS startup procedure. Read the descriptions of the parameters to determine whether you want to accept the system defaults or tailor the system to fit the requirements of your environment.

ARMRST=
 BPECFG=
 BPEINIT=CQSINI00
 CQSGROUP=
 CQSINIT=
 SSN=
 STRDEFG=
 STRDEFL=

Execution data sets

CQS uses two types of data sets, the system checkpoint data set and the structure recovery data set. Both of these data sets must be VSAM entry-sequenced data sets (ESDSs). These data sets are user data sets (and are not known to SMP/E).

CQS system checkpoint data set

Each CQS address space that is connected to a queue structure maintains a system checkpoint data set for each structure pair. Neither CQS address spaces or queue structures share the system checkpoint data set. The CQS initialization process dynamically allocates the system checkpoint data set.

Use the MVS/DFP `DEFINE CLUSTER` functional command to define the data set to the installation. The `DEFINE CLUSTER` function command and its parameters are described in *z/OS DFSMS Access Method Services for Catalogs*.

When you use the `DEFINE CLUSTER` functional command to define the system checkpoint data set, you must specify the following parameters:

NAME

Specifies the same name that you specify using the `CHKPTDSN=` parameter of the CQS local structure definition member of the IMS PROCLIB data set.

NONINDEXED

Specifies that the data set is to be an ESDS.

NONSPANNED

Specifies that the records must be contained in a single control interval.

SHAREOPTIONS

Specifies how a cluster can be shared among users. You must specify `SHAREOPTIONS (2,3)`.

REUSE

Specifies that the cluster can be reused.

The following parameters are recommended when you specify the `DEFINE CLUSTER` functional command:

RECORDSIZE

Specifies the average and maximum length in bytes for the records in the cluster. Both the maximum and minimum length of the `RECORDSIZE` should be 7 bytes less than the `CONTROLINTERVALSIZE`.

CONTROLINTERVALSIZE

Specifies the size of the control interval for the cluster. The recommended `CONTROLINTERVALSIZE` is 512; whatever value you specify must be a multiple of 512.

An example of the system checkpoint data set is shown here:

```
DEFINE CLUSTER -
  (NAME (MSGQ.CHKPT) -
  TRK(2,2) VOL (IMSQAV) NONINDEXED SHAREOPTIONS (2,3) -
  RECSZ(505,505) REUSE CISZ (512))
```

CQS structure recovery data sets

CQS uses two structure recovery data sets per structure pair for its structure checkpoint processing.

Structure recovery data sets are not used for the resource structure.

When a structure checkpoint is requested, CQS dynamically allocates the structure recovery data sets. Structure checkpoint requests alternate between the two structure recovery data sets. During structure checkpoint processing all recoverable data objects on a structure are written to the structure recovery data sets. Thus, the size of each data set should be approximately the size of the primary structure plus the overflow structure to ensure that the entire structure fits in the data set.

Use the MVS/DFP `DEFINE CLUSTER` functional command to define the data set to the installation. The `DEFINE CLUSTER` function command and its parameters are described in *z/OS DFSMS Access Method Services for Catalogs*.

When you use the DEFINE CLUSTER functional command to define the structure recovery data set, you must specify the following parameters.

NAME

Specify the same name you specify in the CQS global structure definition member of the IMS PROCLIB data set using the SRSDSDSN1= and the SRSDSDSN2= parameters.

NONINDEXED

Specifies that the data set is to be an ESDS.

NONSPANNED

Specifies that the records must be contained in a single control interval.

SHAREOPTIONS

Specifies how a cluster can be shared among users. You must specify SHAREOPTIONS (2,3).

REUSE

Specifies that the cluster can be reused.

The following parameters are recommended when you specify the DEFINE CLUSTER functional command:

RECORDSIZE

Specifies the average and maximum length in bytes for the records in the cluster. Both the maximum and minimum length of the RECORDSIZE should be 7 bytes less than the CONTROLINTERVALSIZE.

CONTROLINTERVALSIZE

Specifies the size of the control interval for the cluster. The recommended control interval size is 32 768; whatever value you specify must be a multiple of 512.

An example of the structure recovery data set is shown here:

```
DEFINE CLUSTER -
  (NAME (MSGQ.SRDS1) -
  TRK(45,5) VOL (DSHR03) NONINDEXED SHAREOPTIONS (2,3) -
  RECSZ(32761,32761) REUSE CISZ (32768)
```

Sample Common Queue Server startup procedure using CQSINITO

```
//*****
//*      CQS Procedure
//*
//*
//*      Parameters:
//*      BPECFG - Name of BPE member
//*      CQSINIT - Suffix for your CQSIPxxx member
//*      PARM1 - Other override parameters
//*      ARMRST - ARM restart on CQS failure (Y/N)
//*      CQSGROUP - XCF Group for sharing CQSS
//*      SSN - CQS subsystem name
//*      STRDEFG - Suffix for CQSSGxxx member
//*      STRDEFL - Suffix for CQSSLxxx member
//*
//*      example:
//*      PARM1=' ARMRST=Y,SSN=CQSA,STRDEFG=001,STRDEFL=001 '
//*****
//*      Licensed Materials - Property of IBM
//*
//*      Restricted Materials of IBM
//*
//*      5655-C56
//*
//*      (C) Copyright IBM Corp. 1996,1998
//*****
//*
//CQS      PROC RGN=300M,SOUT=A,
//          RESLIB=' IMS.SDFSRESL ',
//          BPECFG=BPECONFG,
//          CQSINIT=,
//          PARM1=
```

```

//CQSPROC EXEC PGM=CQSINIT0,
//          REGION=&RGN,
// PARM='BPECFG=&BPECFG,CQSINIT=&CQSINIT,&PARM1'
//*
//STEPLIB DD DSN=&RESLIB,DISP=SHR
//          DD DSN=&BPERES,DISP=SHR
//          DD DSN=SYS1.CSSLIB,DISP=SHR
//PROCLIB DD DSN=IMS.PROCLIB,DISP=SHR
//SYSPRINT DD SYSOUT=&SOUT
//SYSUDUMP DD SYSOUT=&SOUT
//*

```

Sample Common Queue Server startup procedure using BPEINI00

```

//*****
//*      CQS Procedure
//*
//*
//*      Parameters:
//*      BPECFG - Name of BPE member
//*      CQSINIT - Suffix for your CQSIPxxx member
//*      PARM1 - Other override parameters
//*              ARMRST - ARM restart on CQS failure (Y/N)
//*              CQSGROUP - XCF Group for sharing CQSS
//*              SSN - CQS subsystem name
//*              STRDEFG - Suffix for CQSSGxxx member
//*              STRDEFL - Suffix for CQSSLxxx member
//*
//*      example:
//*      PARM1='ARMRST=Y,SSN=CQSA,STRDEFG=001,STRDEFL=001'
//*
//*****
//*      Licensed Materials - Property of IBM
//*
//*      Restricted Materials of IBM
//*
//*      5655-C56
//*
//*      (C) Copyright IBM Corp. 1996,1998
//*
//*****
//*
//CQS      PROC RGN=300M,SOUT=A,
//          RESLIB='IMS.SDFSRESL',
//          BPECFG=BPECONFG,
//          CQSINIT=,
//          PARM1=
//*
//CQSPROC EXEC PGM=BPEINI00,
//          REGION=&RGN,
// PARM='BPECFG=&BPECFG,BPEINIT=CQSINI00,CQSINIT=&CQSINIT,&PARM1'
//*
//STEPLIB DD DSN=&RESLIB,DISP=SHR
//          DD DSN=&BPERES,DISP=SHR
//          DD DSN=SYS1.CSSLIB,DISP=SHR
//PROCLIB DD DSN=IMS.PROCLIB,DISP=SHR
//SYSPRINT DD SYSOUT=&SOUT
//SYSUDUMP DD SYSOUT=&SOUT
//*

```

CSLODBM procedure

Use the CSLODBM procedure to dynamically override the settings in the ODBM initialization parameters member of the IMS PROCLIB data set (CSLDIxxx).

You can start ODBM as a started procedure or with JCL. A sample startup procedure called CSLODBM can be found in IMS.SDFSISRC.

Parameters

The following list identifies the parameters that you can specify as execution parameters on the startup procedure for ODBM. The ARMRST, ODBMCFG, and ODBMNAME parameters that are required for ODBM initialization and the optional RRS parameter can also be specified in the CSLDIxxx member of the IMS

PROCLIB data set, documented in [“CSLDIxxx member of the IMS PROCLIB data set”](#) on page 711. Parameters specified on the ODBM procedure override those specified in the CSLDIxxx member of the IMS PROCLIB data set.

```

ARMRST=
BPECFG=
BPEINIT=
ODBMCFG=
ODBMINIT=
ODBMNAME=
RRS=

```

Parameters are described in [“Parameter descriptions for IMS procedures”](#) on page 520.

Sample ODBM startup procedure

The JCL for CSLODBM is shown in the following example.

```

//*****
//*      ODBM Procedure
//*
//*
//*      Parameters:
//*      BPECFG - Name of BPE member
//*      BPEINIT - CSLDINI0, the module that contains the ODBM start up values
//*      ODBMINIT - Suffix for your CSLDIxxx member
//*      PARM1 - other override parameters:
//*              ARMRST - Indicates if ARM should be used
//*              ODBMNAME - Name of ODBM being started
//*              ODBMCFG - Suffix for your CSLDCxxx member
//*              RRS - Indicates RRS is (Y) or is not (N) used
//*
//*      example:
//*      PARM1='ARMRST=Y,ODBMNAME=ODBM1,ODBMCFG=000,RRS=N'
//*
//*****@SCPVRT**
//*
//* Licensed Materials - Property of IBM
//*
//* 5635-A02
//*
//* Copyright IBM Corp. 2011 All Rights Reserved
//*
//* US Government Users Restricted Rights - Use, duplication or
//* disclosure restricted by GSA ADP Schedule contract with
//* IBM Corp.
//*
//*****@ECPVRT**
//*
//CSLODBM PROC RGN=3000K,SOUT=A,
//          RESLIB='IMS.SDFSRESL',
//          BPECFG=BPECONFG,
//          ODBMINIT=000,
//          PARM1=
//*
//ODBMPROC EXEC PGM=BPEINI00,REGION=&RGN,
//          PARM='BPECFG=&BPECFG,BPEINIT=CSLDINI0,ODBMINIT=&ODBMINIT,&PARM1'
//*
//STEPLIB DD DSN=&RESLIB,DISP=SHR
//          DD DSN=SYS1.CSSLIB,DISP=SHR
//PROCLIB DD DSN=IMS.PROCLIB,DISP=SHR
//SYSPRINT DD SYSOUT=&SOUT
//SYSUDUMP DD SYSOUT=&SOUT
//*

```

CSLOM procedure

Use the CSLOM procedure to dynamically override the settings in the OM initialization parameters member of the IMS PROCLIB data set.

You can start OM as a started procedure or with JCL. A sample startup procedure called CSLOM can be found in IMS.SDFSISRC.

Parameters

You can specify the following execution parameters on the startup procedure for OM. Some parameters that are required for OM initialization can also be specified in [“CSLOIxxx member of the IMS PROCLIB data set”](#) on page 714.

```
ARMRST=
BPECFG=
BPEINIT=
CMDLANG=
CMDSEC=
OMINIT=
OMNAME=
```

Parameters are described in [“Parameter descriptions for IMS procedures”](#) on page 520.

Sample OM startup procedure

The JCL for CSLOM is shown here.

```
//*****
//*   OM Procedure
//*
//*
//*   Parameters:
//*   BPECFG - Name of BPE member
//*   OMINIT - Suffix for your CSLOIxxx member
//*   PARM1 - other override parameters:
//*           ARMRST - Indicates if ARM should be used
//*           CMDLANG - Language for command description text
//*           CMDSEC - Command security method
//*           OMNAME - Name of OM being started
//*
//*           example:
//*           PARM1='ARMRST=Y,CMDSEC=R,OMNAME=OM1,CMDLANG=ENU'
//*
//*****@SCPYRT**
//*
//*   Licensed Materials - Property of IBM
//*
//*   "Restricted Materials of IBM"
//*
//*   5635-A01 (C) Copyright IBM Corp. 2011
//*
//*****@ECPYRT**
//*
//CSLOM   PROC RGN=3000K,SOUT=A,
//         RESLIB='IMS.SDFSRESL',
//         BPECFG=BPECONFG,
//         OMINIT=000,
//         PARM1=
//*
//OMPROC  EXEC PGM=BPEINI00,REGION=&RGN,
//         PARM='BPECFG=&BPECFG,BPEINIT=CSLOINI0,OMINIT=&OMINIT,&PARM1'
//*
//STEPLIB DD DSN=&RESLIB,DISP=SHR
//         DD DSN=SYS1.CSSLIB,DISP=SHR
//PROCLIB DD DSN=IMS.PROCLIB,DISP=SHR
//SYSPRINT DD SYSOUT=&SOUT
//SYSUDUMP DD SYSOUT=&SOUT
//*
```

CSLRM procedure

Use the CSLRM procedure to dynamically override the settings in the RM initialization parameters member of the IMS PROCLIB data set (CSLRxxxx).

You can start RM as a started procedure or with JCL. A sample startup procedure named CSLRM can be found in IMS.SDFSISRC.

Parameters

The following parameters can be specified as execution parameters on the RM startup procedure. Some parameters that are required for RM initialization can also be specified in the RM initialization parameters member of the PROCLIB data set (CSLRxxxx).

ARMRST=
BPECFG=
BPEINIT=
RMINIT=
RMNAME=

Sample Resource Manager startup procedure

```
//*****  
//*      RM Procedure  
//*  
//*      Parameters:  
//*      BPECFG  - Name of BPE member  
//*      RMINIT  - Suffix for your CSLRxxxx member  
//*      PARM1   - other override parameters:  
//*                ARMRST - Indicates if ARM should be used  
//*                RMNAME - Name of RM being started  
//*  
//*      example:  
//*      PARM1=' ARMRST=Y,RMNAME=RM1 '  
//*  
//*****@SCPVRT**  
//*      Licensed Materials - Property of IBM      *  
//*      "Restricted Materials of IBM"             *  
//*      5635-A01 (C) Copyright IBM Corp. 2011   *  
//*      *****@ECPYRT**  
//CSLRM   PROC RGN=3000K,SOUT=A,  
//         RESLIB='IMS.SDFSRESL',  
//         BPECFG=BPECONFG,  
//         RMINIT=000,  
//         PARM1=  
//*  
//RMPROC  EXEC PGM=BPEINI00,REGION=&RGN,  
//         PARM=' BPECFG=&BPECFG,BPEINIT=CSLRINI0,RMINIT=&RMINIT,&PARM1 '  
//*  
//STEPLIB DD DSN=&RESLIB,DISP=SHR  
//         DD DSN=SYS1.CSSLIB,DISP=SHR  
//PROCLIB DD DSN=IMS.PROCLIB,DISP=SHR  
//SYSPRINT DD SYSOUT=&SOUT  
//SYSUDUMP DD SYSOUT=&SOUT  
//*
```

CSLSCI procedure

Use the CSLSCI procedure to dynamically override the settings in the SCI initialization parameters member of the IMS PROCLIB data set (CSLSxxxx).

The CSLSCI startup procedure is required, but setting values for the execution parameters is optional. A sample startup procedure called CSLSCI can be found in IMS.SDFSISRC.

Parameters

You can specify the following parameters as execution parameters on the EXEC statement in the SCI startup procedure. Certain parameters that are required for SCI address space initialization can also be specified in the SCI initialization parameters member of the IMS PROCLIB data set (CSLSIxxx).

ARMRST=
BPECFG=
BPEINIT=
FORCE=
SCIINIT=
SCINAME=

Sample SCI startup procedure

```
//*****  
//*      SCI Procedure  
//*  
//*  
//*      Parameters:  
//*      BPECFG - Name of BPE member  
//*      SCIINIT - Suffix for your CSLSIxxx member  
//*      PARM1 - other override parameters:  
//*              ARMRST - Indicates if ARM should be used  
//*              SCINAME - Name of SCI being started  
//*  
//*      example:  
//*      PARM1='ARMRST=Y,SCINAME=SCI1'  
//*  
//*****@SCPVRT**  
//*  
//*      Licensed Materials - Property of IBM  
//*  
//*      "Restricted Materials of IBM"  
//*  
//*      5655-C56 (C) Copyright IBM Corp. 2000  
//*  
//*****@ECPYRT**  
//*  
//CSLSCI  PROC RGN=3000K,SOUT=A,  
//          RESLIB='IMS.SDFSRESL',  
//          BPECFG=BPECONFG,  
//          SCIINIT=000,  
//          PARM1=  
//*  
//SCIPROC EXEC PGM=BPEINI00,REGION=&RGN,  
//          PARM='BPECFG=&BPECFG,BPEINIT=CSLSINI0,SCIINIT=&SCIINIT,&PARM1'  
//*  
//STEPLIB DD DSN=&RESLIB,DISP=SHR  
//          DD DSN=SYS1.CSSLIB,DISP=SHR  
//PROCLIB DD DSN=IMS.PROCLIB,DISP=SHR  
//SYSPRINT DD SYSOUT=&SOUT  
//SYSUDUMP DD SYSOUT=&SOUT  
//*
```

CSLURLFL procedure

Use the CSLURJLO sample job to invoke the CSLURLFL procedure to load the repository server from IMS log records.

Parameters

You can specify the following parameters as execution parameters on the EXEC statement in the CSLURLFL startup procedure.

HLQ=dsn_prefix

Required. Specifies the high level qualifier for the distribution libraries used to install IMS. Specify the dataset name fully qualified without quotes. For example:

HLQ=MY.IMS (for libraries like 'MY.IMS.SDFSISRC')

IMSRESL=dsn

Required. Specifies the fully qualified dataset name of the IMS SDFSRESL to use for the job which is normally &HLQ..SDFSRESL. Specify the dataset name fully qualified without quotes. For example:

```
IMSRESL=&HLQ. .SDFSRESL
```

OLDSDS1=dsn

Required. Defines the first IMS log dataset to use as input to the DFSURCL0 utility. Multiple log datasets can be concatenated using OLDSDSn variables. There should be one OLDSDSn variable for each log data set that is used by the target IMS system. Specify the dataset name fully qualified without quotes. For example:

```
OLDSDS1=MY.OLDS1
```

OLDSDS2-8=dsn

Optional. OLDSDS2 defines the second IMS log dataset to concatenate, if one exists. Similarly, OLDSDS3 would define the third dataset and so on. For example:

```
OLDSDS2=MY.OLDS2
```

Parameters specified by DFSURCL0.CONTROL:

IMSID=ims_id

Required. Specifies the IMSID of the target IMS system. For example:

```
IMSID=IMS1
```

Parameters specified by CSLURP10.SYSIN:

IMSPLEX(NAME=plex IMSID(imsid))

Required. Specifies the IMS plex name and IMSID of the target IMS system. For example:

```
IMSPLEX(NAME=PLEX1 IMSID(IMS1))
```

Sample CSLURJLO JCL

```
//          JOB
//          SET HLQ=
//          SET IMSRESL=
//          SET OLDSDS1=
//          SET OLDSDS2=
// *        SET OLDSDS3=
// *        SET OLDSDS4=
// *        SET OLDSDS5=
// *        SET OLDSDS6=
// *        SET OLDSDS7=
// *        SET OLDSDS8=
// *
//          JCLLIB ORDER=(&HLQ..SDFSISRC)
//JOB LIB   DD DISP=SHR,DSN=&IMSRESL
// *
//STEP1    EXEC CSLURLFL
//DFSURCL0.SYSUT1 DD DISP=SHR,DSN=&OLDSDS1
//          DD DISP=SHR,DSN=&OLDSDS2
// *        DD DISP=SHR,DSN=&OLDSDS3
// *        DD DISP=SHR,DSN=&OLDSDS4
// *        DD DISP=SHR,DSN=&OLDSDS5
// *        DD DISP=SHR,DSN=&OLDSDS6
// *        DD DISP=SHR,DSN=&OLDSDS7
// *        DD DISP=SHR,DSN=&OLDSDS8
//DFSURCL0.CONTROL DD *
//          IMSID=imsid
// *
//CSLURP10.SYSIN DD *
//          IMSPLEX(NAME=plex IMSID(imsid))
// *
//
```

Sample CSLURLFL procedure

```
// *
//CSLURLFL PROC
// *
//*****
```



```

// * * *                               DFSURCL0                               * * *
//*****
//DFSURCL0 EXEC PGM=DFSURCL0
//SYSUT1 DD DUMMY
//CONTROL DD DUMMY
//REPORT DD SYSOUT=*
//WORKFILE DD SYSOUT=*,
//          DCB=(LRECL=133, BLKSIZE=6118, RECFM=FBA)
//RDDSDSN DD DISP=(, PASS),
//          DSN=&&RDDSDSN,
//          UNIT=SYSDA,
//          SPACE=(CYL, (100, 50), RLSE),
//          DCB=(RECFM=VB, LRECL=32756, BLKSIZE=32760)
//SYSUDUMP DD SYSOUT=*
//SYSPRINT DD SYSOUT=*
//*
//*****
// * * *                               CSLURP10                               * * *
//*****
//CSLURP10 EXEC PGM=CSLURP10, MEMLIMIT=4G
//SYSUDUMP DD SYSOUT=*
//SYSPRINT DD SYSOUT=*
//RDDSDSN DD DISP=(OLD, PASS),
//          DSN=&&RDDSDSN,
//          UNIT=SYSDA
//SYSIN DD DUMMY
//          PEND

```

DBBBATCH procedure

The DBBBATCH procedure is a one-step procedure for running an offline DL/I batch processing region using either an IMS.ACBLIB or the IMS catalog.

The JCL shown in [“Sample procedure to run offline DL/I batch processing region using IMS.ACBLIB” on page 603](#) can be used to run an offline DL/I batch processing region using IMS.ACBLIB.

If the IMS management of ACBs is enabled, the offline DL/I batch processing region retrieves the ACBs from the IMS catalog instead of the IMS.ACBLIB. Any specification of the IMSACBA and IMSACBB DD statements are ignored and can be omitted from the JCL.

The enablement of the IMS management of ACBs is determined by the ACBMGMT= parameter in the <CATALOG> section of the DFSDFxxx PROCLIB member or it can be indicated in a batch environment by turning the DXPL_FUNDIREN flag on in the DXPL_FUNCV2 byte in the IMS Catalog Definition exit routine (DFS3CDX0).

If VSAM databases are used, see [“IMS buffer pools” on page 206](#).

Usage

In the sample DBBBATCH procedure that is built during SMP/E processing and placed in the ADFSPROC and SDFSPROC library data sets, the IEFRDER2 DD statement is included as a comment. To use the IEFRDER2 DD statement, remove the asterisks (*).

In the example shown in [“Sample procedure to run offline DL/I batch processing region using IMS.ACBLIB” on page 603](#):

- The parameters in parentheses are positional.
- The JCL is for an XRF-capable system only.
- The IEFRDER statement is not required in DB/DC or DBCTL environments if the job does not declare database update intent.

In IMS systems that use ACB libraries, if the batch application program will process a HALDB database for which a HALDB alter operation was started but the online change function is not yet done, the IMSACB DD statement in the DBBBATCH procedure must specify the active ACB library that contains the original, unaltered database definition. The IMSACB statement must specify the active ACB library regardless of the fact that some or all of the segments in the database might now conform to the format defined by the new database definition in the staging ACB library. IMS automatically gets the altered definition from the staging ACB library, but requires the original, unaltered database definition for comparison.

For a job step declaring database update intent, DD DUMMY can be specified, if the job step is not using DBRC. This specification is valid where an image copy of the database is taken before the update job step.

Log initialization calculates the smallest value necessary for logical record length. If the JCL logical record length value is larger than the calculated value, the JCL value is used. Otherwise, log initialization uses the calculated value for logical record length and adds 4 for the block size.

If multiple volumes are required for the system log, specify a volume count value in the VOL parameter of the DD statement.

For information about the number of volumes required per DD statement, see *MVS/ESA Job Control Language User's Guide*.

If the IBM 3480 tape drive is used for the IMS log data set, IMS forces tape write mode (DCB=OPTCD=W). The default on the 3480 is to buffer the write so that IMS cannot detect when the write is performed. If a power failure occurs after a log record is written to the 3480, and the database is updated but the log record is not yet written to tape, database integrity is lost. Tape write mode is forced for the log in batch and GSAM data sets.

Parameters

The following parameters are valid for the DBBBATCH procedure:

APARM=
BKO=
BUF=
CKPTID=
DBRC=
DBRCGRP=
DFSDF=
FMTO=
GSGNAME=
IMSID=
IRLM=
IRLMNM=
IMSPLEX=
LOCKMAX=
MON=
NODE1=
NODE2=
PRLD=
PSB= (optional)
RGN=
RGSUF= (no default when specified in the batch procedure)
RRS=
SOUT=
SRCH=
SSM=
SWAP=
SYS=
SYS2=
TMINAME=

The following parameters cannot be specified in the PARM1= and PARM2= parameters:

EXCPVR=
MBR=

RST=
SPIE=
TEST=

The IOB parameter is no longer used and is ignored if it is specified.

See [“Parameter descriptions for IMS procedures” on page 520](#) for parameter definitions.

DD statements

The following DD statements are valid for the DBBBATCH procedure.

In addition to these DD statements, add statements for data sets representing IMS databases that are not to be dynamically allocated.

The following DD statements are required:

DFSRESLB DD
DFSVSAMP DD
IEFRDER DD
IMSACB DD, except when the IMS management of ACBs is enabled
IMSACBA DD, except when the IMS management of ACBs is enabled
IMSACBB DD, except when the IMS management of ACBs is enabled
IMS LOGR DD
MODSTAT DD
MODSTAT2 DD
OLCSTAT DD
PROCLIB DD
STEPLIB DD
SYSUDUMP DD

The following DD statements are optional:

DFSHALDB DD
DFSSTAT DD
IEFRDER2 DD
IMS DD
RECON_n DD
SYSHALDB DD

IMSDALIB is not included in the list of valid DD statements for the DBBBATCH procedure because it is not supported in batch mode.

See [“DD statements for IMS procedures” on page 583](#) for explanations of the DD statements.

Sample procedure to run offline DL/I batch processing region using IMS.ACBLIB

```
//      PROC MBR=TEMPNAME,PSB=,BUF=7,  
//          SPIE=0,TEST=0,EXCPVR=0,RST=0,PRLD=,  
//          SRCH=0,CKPTID=,MON=N,LOGA=0,FMTO=T,  
//          IMSID=,SWAP=,DBRC=,IRLM=,IRLMNM=,  
//          BK0=N,IOB=,SSM=,APARM=,  
//          RGN=4M,RGSUF=,PARM1=,PARM2=,  
//          SOUT=A,LOGT=2400,  
//          SYS=,  
//          SYS2=,LOCKMAX=,  
//          GSGNAME=,TMINAME=,RRS=N,  
//          IMSPLEX=,DFSDF=  
//G     EXEC PGM=DFSRR00,REGION=&RGN,  
//          PARM=(DBB,&MBR,&PSB,&BUF,  
//          &SPIE&TEST&EXCPVR&RST,&PRLD,  
//          &SRCH,&CKPTID,&MON,&LOGA,&FMTO,  
//          &IMSID,&SWAP,&DBRC,&IRLM,&IRLMNM,  
//          &BK0,&IOB,&SSM,  
//          '&APARM',&LOCKMAX,
```

```

//          &GSGNAME,&TMINAME,&RRS,
//          &IMSPLEX,&RGSUF,&DFSDF,
//          '&PARM1','&PARM2')
//STEPLIB DD DSN=IMS.&SYS2.SDFSRESL,DISP=SHR
//          DD DSN=IMS.&SYS2.PGMLIB,DISP=SHR
//DFSRESLB DD DSN=IMS.&SYS2.SDFSRESL,DISP=SHR
//IMSACBA DD DSN=IMS.&SYS2.ACBLIBA,DISP=SHR
//IMSACBB DD DSN=IMS.&SYS2.ACBLIBB,DISP=SHR
//MODSTAT DD DSN=IMS.&SYS.MODSTAT,DISP=SHR
//MODSTAT2 DD DSN=IMS.&SYS.MODSTAT2,DISP=SHR
//PROCLIB DD DSN=IMS.&SYS2.PROCLIB,DISP=SHR
//IEFRDER DD DSN=IMSLOG,DISP=(,KEEP),VOL=(,,99),
//          UNIT=(&LOGT,,DEFER),
//          DCB=(RECFM=VB,BLKSIZE=4096,
//          LRECL=4092,BUFNO=2)
//IEFRDER2 DD DSN=IMSLOG2,DISP=(,KEEP),VOL=(,,99),
//          UNIT=(&LOGT,,DEFER,SEP=IEFRDER),
//          DCB=(RECFM=VB,BLKSIZE=4096,
//          LRECL=4092,BUFNO=2)
//SYSUDUMP DD SYSOUT=&SOUT,
//          DCB=(RECFM=FBA,LRECL=121,BLKSIZE=605),
//          SPACE=(605,(500,500),RLSE,,ROUND)
//IMSMON DD DUMMY

```

DBC procedure

The DBC procedure is an online execution procedure to initialize the DBCTL environment.

If dynamic resource definition (DRD) for resources in the IMS.MODBLKS data set is enabled, and you are no longer using the MODBLKS data sets, this procedure no longer requires the DD statements for the MODBLKS data sets, MODBLKSA and MODBLKSB.

JCL

The procedure shown in the following example executes an IMS DBCTL control region.

```

//          PROC RGN=64M,SOUT=A,DPTY='(14,15)',
//          SYS=,SYS2=,
//          LOGT=2400,SYS1=,
//          RGSUF=DBC,PARM1=,PARM2=
//IEFPROC EXEC PGM=DFSVMRC0,DPRTY=&DPTY,REGION=&RGN,
//          PARM='DBC,&RGSUF,&PARM1,&PARM2'
//*
//*
//* THE MEANING AND MAXIMUM SIZE OF EACH PARAMETER
//* IS AS FOLLOWS:
//*****
//* RGSUF XXX EXEC PARM DEFAULT BLOCK SUFFIX FOR
//* MEMBER DFSPBXXX.
//*****
//* PARM1 , PARM2 PARAMETERS BOTH ARE USED TO SPECIFY
//* CHARACTER STRINGS THAT CONTAIN IMS KEYWORD
//* PARAMETERS. I.E. PARM1='AUTO=Y,PST=222,RES=Y'
//*
//* ALL OF THE VALID DBCTL KEYWORD PARAMETERS
//* ARE DESCRIBED BELOW
//*****
//*
//***** CONTROL REGION SPECIFICATIONS *****
//* RES X BLOCK RESIDENT (N = NO, Y = YES)
//* PST XXX NUMBER OF PST'S PERMANENTLY ALLOC
//* MAXPST XXX MAXIMUM NUMBER OF PST'S
//* SRCH X MODULE SEARCH INDICATOR FOR DIRECTED LOAD
//*          0 = STANDARD SEARCH
//*          1 = SEARCH JPA AND LPA BEFORE PDS
//* FMT0 T = ONLINE FORMATTED DUMP WITH
//*          STORAGE IMAGE DELETIONS.
//*          TERM=NO SDUMPS ALLOWED.
//*          P = FULL ONLINE FORMATTED DUMP.
//*          TERM=NO SDUMPS ALLOWED.
//*          F = FULL ONLINE FORMATTED DUMP.
//*          TERM=NO SDUMPS NOT ALLOWED.
//*          N = NO FORMATTED DUMP, NO OFFLINE
//*          DUMP. TERM=NO SDUMPS ALLOWED.
//*          Z = NO FORMATTED DUMP, NO OFFLINE
//*          DUMP. TERM=NO SDUMPS NOT

```

```

/**
/** (DEFAULT) D = OFFLINE DUMP, OR ONLINE FORMAT-
/**          TED DUMP WITH STORAGE IMAGE
/**          DELETIONS IF OFFLINE DUMPING
/**          FAILS. TERM=NO SDUMPS ALLOWED.
/**          X = OFFLINE DUMP, OR ONLINE FORMAT-
/**          TED DUMP WITH STORAGE IMAGE
/**          DELETIONS IF OFFLINE DUMPING
/**          FAILS. TERM=NO SDUMPS NOT
/**          ALLOWED.
/**          M = OFFLINE DUMP, ONLINE IMS DUMP
/**          FORMATTING NOT PERMITTED
/**          TERM=NO SDUMPS ALLOWED.
/**          R = OFFLINE DUMP, ONLINE IMS DUMP
/**          FORMATTING NOT PERMITTED
/**          TERM=NO SDUMPS NOT ALLOWED.
/** AUTO X Y = AUTOMATIC RESTART DESIRED
/**          N = NO AUTOMATIC RESTART
/** IMSID XXXX IMS SUBSYSTEM IDENTIFIER
/** ISIS X N = NO RESOURCE ACCESS SECURITY
/**          R = RACF RESOURCE ACCESS SECURITY
/**          C = RACF RESOURCE ACCESS SECURITY
/**          A = RACF RESOURCE ACCESS SECURITY
/** ARMRST X Y = ALLOW MVS ARM TO RESTART
/**          N = ARM NOT RESTART IMS
/** RRS X Y = ENABLE PROT CONV SUPPORT
/**          N = DISABLE PROT CONV SUPPORT
/** IRLM X Y = YES, N = NO
/** IRLMNM XXXX IRLM SUBSYSTEM NAME
/** SSM XXXX EXT SUBSYSTEM PROCLIB MEMBER ID
/** UHASH XXXXXXXX USER HASH MODULE NAME
/** DBRCNM XXXXXXXX DBRC PROCLIB MEMBER NAME
/** DLINM XXXXXXXX DL/I PROCLIB MEMBER NAME
/** PRDR XXXXXXXX IMSRDR PROCLIB MEMBER NAME
/** DBRSE XXXXXXXX 8 CHAR DBCTL RSENAME
/** CRC X COMMAND RECOGNITION CHARACTER
/** CMDMCS X COMMAND SECURITY OPTION
/**          R=RACF COMMAND SECURITY
/**          C=DFSCCMD0 COMMAND SECURITY
/**          B=RACF AND DFSCCMD0 CMD SEC
/** PREMSG X PREFIX MESSAGE OPTION
/**          N=NO DFS000I PREFIX
/**          Y=DEFAULT, DFS000I PREFIX
/** PIMAX XXXXXX ENQ/DEQ POOL MAXIMUM BYTES
/** PIINCR XXXXXX ENQ/DEQ POOL INCREMENT
/** AOIS X ICDM SECURITY OPTION
/** PSWDC X PASSWORD CASE
/**          U=UPPER CASE
/**          M=MIXED CASE
/**          R=USES RACF SETTING (DEFAULT)
/** YEAR4 X N = 2-DIGIT DATE (DEFAULT)
/**          Y = 4-DIGIT DATE
/** CPLOG XXXXXX CHECKPOINT LOG INTERVAL
/**          OR
/** CPLOG XXM CHECKPOINT LOG INTERVAL
/** IMSGROUP XXXX 4 CHAR USER SPEC NAME
/** DESC XX MSG DESC CODE
/** MCS (XX,XX) MSG ROUTE CODES
/** SVC2 XXX TYPE 2 SVC NUMBER
/** CCTVCAN X Y = CCTL CANCEL WILL BE CONVERTED
/**          TO ABEND SYSTEM 08E
/**          N = CCTL CANCEL IS NOT CONVERTED
/**
/******* FDR PARAMETER *****
/**
/** FDRMBR XX SUFFIX FOR FDR MEMBER IN
/**          IMS.PROCLIB
/**
/******* FAST PATH PARAMETERS *****
/**
/** BSIZ XXX DATA BASE BUFFER SIZE
/** OTHR XXX NUMBER OF OUTPUT THREADS
/** DBFX XXX SYSTEM ALLOCATION OF DATA BASE BUFFERS TO BE
/**          FIXED AT START OF 1ST FAST PATH DEP REGION
/** DBBF XXX NUMBER OF DATABASE BUFFERS
/** DBFP XXXX PAGE FIX/FREE ADJUST TIMER
/**          0: FIX/FREE AT SCHED/TERM
/**          1: ALLOW PAGEFIX ONLY
/**          2-3600: SEC PAGEFREE FREQ
/** LGNR XX NUMBER OF LOG ENTRIES IN DEDB BUFFERHEADER
/** SVSODR XXXX SVSO DISASTER RECOVERY OPTIONS
/**          NONE: DEFAULT. NO CHANGE TO ERE.

```

```

//*          AUTO: AREA MARKED RECOV NEEDED IF
//*
//*          DRRS: AREA MARKED RECOV NEEDED AT
//*
//*          WTOR: USER OPTION TO MARK AREAS
//*
//*          DMHVF XX  MEGS TO FIX PAGEFIX FOR VSO ERE DATASPACE
//*          FPOPN X   PREOPEN/REOPEN OPTIONS FOR DEDBS
//*                   N: DEFAULT. PREOPEN OF DEDB AREAS
//*                   DONE BEFORE IMS RESTART
//*                   COMPLETES
//*                   R: REOPEN AREAS OPENED WHEN IMS
//*                   ABNORMALLY TERMINATED. BEHAVE
//*                   LIKE OPTION P FOR NON /ERE
//*                   P: PREOPEN OF DEDB AREA
//*                   INITIATED AT THE END OF
//*                   RESTART
//*          FPRLM X   A: OPTION R AND P COMBINED
//*                   DEDB OPTIONS FOR IRLM RECONNECT
//*                   N: DEFAULT. NO ACTION TAKEN
//*                   S: RESTART ALL DEDB AREAS WHICH
//*                   WERE STARTED WHEN IRLM
//*                   DISCONNECTED
//*                   R: RESTART AND REOPEN ALL DEDB
//*                   AREAS WHICH WERE STARTED WHEN
//*                   IRLM DISCONNECTED
//*                   P: PREOPEN OF DEDB AREA
//*                   INITIATED AT THE END OF
//*                   IRLM RECONNECT
//*          FP      X   A: COMBINE OPTIONS R AND P
//*                   INCLUDE FASTPATH IN THIS IMS
//*                   N: THE DEFAULT. THIS IMS DOES
//*                   NOT INCLUDE FASTPATH
//*                   Y: THIS IMS INCLUDES FASTPATH

//***** STORAGE POOL VALUES IN K, M OR G *****
//*          DMB      XXXXXX DMB POOL SIZE
//*          CIOP     XXXXXX CIOP POOL UPPER LIMIT
//*          WKAP     XXXXXX WORKING STORAGE BUFFER POOL SIZE
//*          PSBW     XXXXXX PSB WORK POOL SIZE
//*          DBWP     XXXXXX DATABASE WORK POOL SIZE
//*          CSAPSB   XXXXXX DLISAS: CSA PSB POOL SIZE
//*          DLIPSB   XXXXXX DLISAS: DLI PSB POOL SIZE
//*          EPCB     XXXXXX EPCB POOL SIZE
//*          FWP      XXXXXX FP WORK POOL UPPER LIMIT
//*          AOIP     XXXXXX AOI POOL UPPER LIMIT
//*          CMDP     XXXXXX CMDP POOL UPPER LIMIT
//*
//***** MEMBER SUFFIXES *****
//*          SUF      X      LAST CHARACTER OF CTL PROGRAM LOAD
//*                   MODULE MEMBER NAME
//*          FIX      XX     2 CHARACTER FIX PROCEDURE MODULE SUFFIX
//*          PRLD     XX     2 CHARACTER PROCLIB MEMBER SUFFIX FOR PRELOAD
//*          VSPEC    XX     2 CHARACTER BUFFER POOL SPEC MODULE SUFFIX
//*          SPM      XX     STORAGE POOL OPTIONS (DFSSPMXX)
//*          CSLG     XXX    CSL GLOBAL MEMBER (DFSCGXXX)
//*          DFSDF    XXX    DRD, CSL, AND SQ MEMBER (DFSDFXXX)
//*****
//*
//STEPLIB DD DSN=IMS.&SYS2.SDFSRESL,DISP=SHR
//PROCLIB DD DSN=IMS.&SYS2.PROCLIB,DISP=SHR
//*
//*****
//* IN ORDER TO START A DEPENDENT REGION, MODIFIED
//* START-UP JCL IS WRITTEN FROM INTERNAL STORAGE TO
//* THE INTERNAL READER.
//*
//IMSIRD DD SYSOUT=(A,INTRDR)
//***** IMSMON DD CARDS *****
//*
//* THE IMSMON DD STATEMENT MUST BE REMOVED IF
//* THIS DATA SET IS TO BE DYNAMICALLY ALLOCATED.
//* THE IMSACBA AND IMSACBB DD STATEMENTS MUST BE
//* REMOVED IF YOU WISH TO DYNAMICALLY ALLOCATE THE
//* ACBLIB DATA SETS THROUGH THE DFSMDA MEMBER.
//*
//IMSMON DD DSN=IMS.&SYS1.IMSMON,DISP=(,KEEP),
//        VOL=(, ,99),UNIT=(&LOGT, ,DEFER)
//*
//IMSACBA DD DSN=IMS.&SYS2.ACBLIBA,DISP=SHR
//IMSACBB DD DSN=IMS.&SYS2.ACBLIBB,DISP=SHR

```

```

//MODBLKSA DD DSN=IMS.&SYS2.MODBLKSA,DISP=SHR
//MODBLKSB DD DSN=IMS.&SYS2.MODBLKSB,DISP=SHR
//MODSTAT DD DSN=IMS.&SYS.MODSTAT,DISP=SHR
//***** SYSTEM REQUIRED DD CARDS *****
//*
//SYSUDUMP DD SYSOUT=&SOUT,
//          DCB=(LRECL=125,RECFM=FBA,BLKSIZE=3129),
//          SPACE=(6050,300,,ROUND)
//IMSRDS DD DSN=IMS.&SYS.RDS,DISP=SHR
//PRINTDD DD SYSOUT=&SOUT
//*
//***** EXTERNAL SUBSYSTEM DD CARDS *****
//*
//* USER MAY OPTIONALLY ADD THE DFSESL DD CARD
//* FOR EXTERNAL SUBSYSTEM CONNECTION.
//*
//***** DATA BASE DD CARDS *****
//*
//* USER MAY OPTIONALLY SUPPLY THE DD STATEMENTS
//* FOR THE ON-LINE DATA BASES TO BE
//* INSERTED HERE PRIOR TO ATTEMPTING
//* AN ON-LINE SYSTEM EXECUTION USING
//* THIS PROCEDURE.
//* IF NO DD STATEMENTS ARE SUPPLIED FOR
//* A DATA BASE, IMS ASSUMES THAT THIS
//* DATA BASE HAS BEEN DESCRIBED THROUGH
//* THE DFSMDA MACRO.
//* IF THE USER WILL BE EXECUTING WITH THE DL/I
//* SAS OPTION, THESE DD STATEMENTS SHOULD BE ADDED
//* TO THE DLISAS PROCLIB MEMBER OR DESCRIBED
//* THROUGH THE DFSMDA MACRO.

```

Usage

If DL/I databases are used, a member DFSVSMxx is built in the IMS PROCLIB data set. See [“IMS buffer pools”](#) on page 206.

DEDB areas must be allocated in the DBCTL control region. One of the following must occur:

- The DD statements must be in the control region JCL.
- The dynamic allocation members must be in a library, as addressed by JOBLIB and STEPLIB.

If you are defining your resources dynamically, the DD statements for the MODBLKS data sets are no longer required.

DBCTL execution parameters can be specified on the DBC EXECUTE statement, in the DBC procedure, or in the defaults member DFSPBDBC, or the parameter default values that are specified during system definition can be used.

Parameters

The following parameters are valid for the DBC procedure. See [“Parameter descriptions for IMS procedures”](#) on page 520 for descriptions of the parameters.

AOIP= to FDRMBR=	FIX= to PREMSG=	PRLD= to YEAR4
AOIP=	FIX=	PRLD=
AOIS=	FMTO=	PSBW=
ARMRST=	FP=	PST=
AUTO=	FPDSSIZE=	PSWDC=
BSIZ=	FPOPN=	RCLASS=
CCTCVCAN=	FPRLM=	RDS=
CIOP=	FPWP=	RES=
CMDMCS=	IMSGROUP=	RGSUF=
CRC=	IMSID=	RRS=
CSAPSB=	IOVF=	SPM=
CSLG=	IRLM=	SRCH=
DBBF=	IRLMNM=	SSM=
DBFP=	ISIS=	SUF=
DBFX=	LGNR=	SVC2=
DBRCNM=	MAXPST=	SVSODR=
DBRSE=	MCS=	TSR=
DBWP=	NODE1=	UHASH=
DESC=	NODE2=	VSPEC=
DFSDF=	ODBASE=	WKAP=
DLINM=	ORSMBR=	YEAR4=
DLIPSB=	OTHR=	
DMB=	PIINCR=	
DMHVF=	PIMAX=	
EPCB=	PRDR=	
FDRMBR=	PREMSG=	

DD statements

The following DD statements are valid for the DBC procedure.

In addition to the following DD statements, add statements for data sets representing IMS databases that are not to be dynamically allocated.

See [“DD statements for IMS procedures” on page 583](#) for descriptions of the DD statements.

- DFSESL DD (optional)
- DFSOLPnn DD
- DFSOLSNnn DD
- DFSWADSn DD
- IMSACBA DD
- IMSACBB DD
- IMSDALIB DD (optional)
- IMSIRD DD
- IMSMON DD
- IMSRDS DD
- MODBLKSA DD
- MODBLKSB DD
- MODSTAT DD
- PRINTDD DD
- PROCLIB DD
- RECON1 DD (optional)

RECON2 DD (optional)
 RECON3 DD (optional)
 STEPLIB DD
 SYSUDUMP DD

Important:

- If you are defining your resources dynamically, the DD statements for the MODBLKS data sets (MODBLKSA DD and MODBLKSB DD) are no longer required.
- IMSACBA DD and IMSACBB DD must be removed if you want to dynamically allocate the ACBLIB data sets through the DFSMDA member.
- In the sample DBC procedure that is built during SMP/E processing and placed in the ADFSPROC and SDFSPROC library data sets, the IMSMON DD statement is included as a comment. To use the IMSMON DD statement, remove the asterisks (*).

Restrictions

The DBC procedure is used as-is for both regions in a DBCTL stand-by configuration.

DBRC procedure

The DBRC procedure is an online execution procedure that initiates DBRC. To take advantage of additional features provided with Base Primitive Environment (BPE) (such as BPE tracing or improved DBRC user exit services), start DBRC in a BPE.

JCL

Both the standard DBRC procedure and the BPE-based DBRC procedure run in a separate address space.

A sample procedure to run DBRC in BPE, DSPBPROC, is supplied in IMS.SDFSISRC.

The following procedure initializes DBRC and is executed by IMS using a z/OS START command during control region initialization.

```
//          PROC RGN=64M,DPTY='(14,15)',SOUT=A,
//          IMSID=SYS3,SYS2=
//IEFPROC EXEC PGM=DFSMVRC0,REGION=&RGN,
//          DPRTY=&DPTY,PARM='DRC,&IMSID'
//*****
//*
//STEPLIB DD DSN=IMS.&SYS2.SDFSRESL,DISP=SHR
//PROCLIB DD DSN=IMS.&SYS2.PROCLIB,DISP=SHR
//JCLOUT DD SYSOUT=(A,INTRDR)
//JCLPDS DD DSN=IMS.&SYS2.PROCLIB,DISP=SHR
//SYSUDUMP DD SYSOUT=&SOUT
//SYSABEND DD SYSOUT=&SOUT
//*
//***** DBRC RECON DD CARDS *****
//*
//* USER MAY OPTIONALLY SUPPLY THE DD CARDS
//* REQUIRED FOR THE DBRC RECON DATA SET.
//* IF NO DD STATEMENTS ARE SUPPLIED FOR RECON
//* DATASETS, IMS ASSUMES THAT THE DATASETS
//* HAVE BEEN DESCRIBED THROUGH THE DFSMDA MACRO.
```

The following procedure initializes DBRC in a BPE and is executed by IMS using a z/OS START command during control region initialization.

```
//*****
//* DBRC Procedure - BPE Environment
//*
//* Parameters:
//* BPECFG - Name of BPE member
//* DBRCINIT - Suffix for your DSPBIxxx member
//* IMSID - IMS Control region ID (required)
//* PARM1 - other override parameters:
//* BPEINIT=DSPBINI0 (required)
```

```

//*          IMSPLEX - IMSplex name
//*          DBRCGRP - DBRC sharing group ID
//*
//*          example:
//*          PARM1='BPEINIT=DSPBINIO,IMSPLEX=PLEX1'
//*
/*****@SCPYRT**
//*
//* Licensed Materials - Property of IBM
//*
//* 5635-A02
//*
//* (C) Copyright IBM Corp. 2008      All Rights Reserved
//*
//* US Government Users Restricted Rights - Use, duplication or
//* disclosure restricted by GSA ADP Schedule contract with
//* IBM Corp.
/*****@ECPYRT**
//*
//DBRC      PROC RGN=0M,SOUT=A,
//          RESLIB='IMS.SDFSRESL',
//          BPECFG=BPECFG,
//          DBRCINIT=000,
//          IMSID=IMS1,
//          PARM1='BPEINIT=DSPBINIO'
//*
//DBRCPROC  EXEC PGM=BPEINI00,REGION=&RGN,
// PARM='BPECFG=&BPECFG,DBRCINIT=&DBRCINIT,IMSID=&IMSID,&PARM1'
//*
//STEPLIB  DD DSN=&RESLIB,DISP=SHR
//          DD DSN=SYS1.CSSLIB,DISP=SHR
//PROCLIB  DD DSN=IMS.PROCLIB,DISP=SHR
//SYSPRINT DD SYSOUT=&SOUT
//SYSUDUMP DD SYSOUT=&SOUT
//JCLOUT   DD SYSOUT=(A,INTRDR)
//JCLPDS   DD DSN=IMS.PROCLIB,DISP=SHR
//SYSABEND DD SYSOUT=&SOUT
//*
//*
//* User may optionally supply the DD cards
//* required for the DBRC RECON data sets.
//* If no DD statements are supplied for RECON
//* data sets, IMS assumes that the data sets
//* have been described through the DFSMDA macro.

```

Usage

The sample DBRC procedure resides in IMS.SDFSPROC specified in the DBRC=*member* parameter. This *member* must be copied to SYS1.PROCLIB.

The IMS control region automatically initiates the DBRC procedure. The PDS member name that IMS uses for the DBRC procedure is defined and can be overridden as follows:

1. DBRC is the default name.
2. The value specified on the DBRCNM= keyword in the IMSCTRL macro overrides the default name.
3. The value specified on the DBRCNM= keyword in the DFSPBxxx member of the IMS PROCLIB data set overrides the value specified in the IMSCTRL macro.
4. The value specified on the DBRCNM= keyword in the JCL EXEC parameter overrides the value specified in the DFSPBxxx member of the IMS PROCLIB data set.

Example START commands:

- START IMSRDR, MBR=DBRC: the PDS member specified is read as a job through the z/OS internal reader. It starts as a job rather than as a started task.
- START DBRC, IMSID=IMSA: DBRC executes as a started task. DBRC connects to IMSA.

When DBRC connects to the IMS control region, the DBRC procedure name is compared with the DBRCNM= specification. If they are not the same, DBRC abends.

Automatic initiation

A z/OS START command is issued for DBRCNM. The z/OS START command is coded to override the PARM='DRC,&IMSID' procedure statement. The override defines the IMSID of the subsystem issuing the START command, and allows a generic procedure to be used by multiple IMS control regions.

IMS does not issue the IMS READY message until DBRC successfully initiates. If the DBRC procedure started by the control region is in error, correct the procedure and restart it.

Manual initiation

You can supply a START command instead of the internally defined START. The START command is supplied in member =DBRCNM of a PDS defined in //PROCLIB in the control region JCL. If columns 1-5 are not "START", message DFS1930I is issued and the internal START command is issued as if the DBRCNM member was not found in the IMS PROCLIB data set.

Parameters

The following parameters are valid for the DBRC procedure. See [“Parameter descriptions for IMS procedures”](#) on page 520 for descriptions of the parameters.

BPECFG=
BPEINIT=
DBRCGRP=
DBRCINIT=
DPRTY=
IMSID=
IMSPLEX=
NODE2=
RGN=
SOUT=
SYS2=

DD statements

The following DD statements are valid for the DBRC procedure. See [“DD statements for IMS procedures”](#) on page 583 for descriptions of the statements.

IMSDALIB DD (optional)
JCLOUT DD
JCLPDS DD
PROCLIB DD
RECONn DD (optional)
STEPLIB DD
SYSABEND DD
SYSUDUMP DD

DCC procedure

The DCC procedure is an online execution procedure to initialize the DCCTL environment.

If dynamic resource definition (DRD) is enabled for your runtime resource definitions, and you are no longer using the IMS.MODBLKS data sets, this procedure no longer requires the DD statements for the IMS.MODBLKS data sets, MODBLKSA and MODBLKSB.

Modify the DCC procedure to specify the actual DD statements that are needed by the installation. The DCC parts contain examples on how these DD statements should be coded based on the actual definitions defined by the installation.

Parameters

The following parameters are valid for the DCC procedure. See [“Parameter descriptions for IMS procedures”](#) on page 520 for descriptions of the parameters.

ALOT= to FBP=	FESTIM= to OTMANM=	OTMASE= to RVFY=	SAV= to YEAR4=
ALOT=	FESTIM=	OTMANM=	SAV=
AOIP=	FIX=	OTMASE=	SGN=
AOIS=	FMTO=	OTMASP=	SHAREQ=
AOI1=	FRE=	PASSWD1=	SHMSGSZ=
APPC=	GRNAME=	PRDR=	SIMEXIT=
APPCSE=	GRSNAME=	PRLD=	SOD=
APPLID1=	HIOP=	PSB=	SOUT=
APPLID2=	HSBID=	PSBW=	SPM=
APPLID3=	HSBMBR=	PST=	SRCH=
ARMRST=	IMSGROUP=	PSWDC=	SSM=
ASOT=	IMSID=	QBUF=	SUF=
AUTO=	ISIS=	QBUFHITH=	SVC2=
CIOP=	LGMSGSZ=	QBUFLWTH=	SYS=
CMDMCS=	LHTS=	QBUFMAX=	SYS1=
CPLOG=	LTERM=	QBUFPCTX=	SYS2=
CRC=	LUMC=	QBUFSZ=	TCORACF=
CSLG=	LUMP=	QTL=	
DBRCNM=	MAXPST=	QTU=	TRN=
DC=	MCS=	RCF=	TSR=
DESC=	MFSEXITF=	RCFTCB=	UHTS=
DSCT=	MFSEXITS=	RCLASS=	USERMSG=
DYNP=			USERVAR=
EMHB=	NHTS=	RECA=	VAUT=
EMHL=	NLXB=	RECASZ=	VSPEC=
EPCB=	NODE1=	RES=	WKAP=
ETO=	NODE2=	RGN=	YEAR4=
EXVR=	OTMA=	RGSUF=	
FBP=	OTMAASY=	RRS=	
FESEXIT=	OTMAMD=	RVFY=	

DD statements

The following table lists the valid DD statements for the DCC procedure. See also [“DD statements for IMS procedures”](#) on page 583.

DFSDUPPM to IMSMON	IMSRDS to PRINT	PROCLIB to SYSUDUMP
DFSDUPPM DD	IMSRDS DD	PROCLIB DD
DFSESL DD (optional)	IMSRDS2 DD	QBLKS DD
DFSOLPnn DD	IMSTFMTA DD	QBLKSL DD
DFSOLSnn DD	IMSTFMTB DD	RECON1 DD (optional)
DFSTCF DD (optional)	LGMSG DD	RECON2 DD1 (optional)
FORMATA DD	LGMSGL DD	RECON3 DD1 (optional)
FORMATB DD	MODBLKSA DD	SHMSG DD
IMSACBA DD	MODBLKSB DD	SHMSGL DD
IMSACBB DD	MODSTAT DD	STEPLIB DD
IMSDALIB DD (optional)		
IMSIRD DD	MODSTAT2 DD	SYSABEND DD
IMSMON DD	PRINT DD	SYSUDUMP DD

Important:

- If you are defining your resources dynamically, the DD statements for the MODBLKS data sets (MODBLKSA DD and MODBLKSB DD) are no longer required.
- IMSACBA DD and IMSACBB DD must be removed if you want to dynamically allocate the ACBLIB data sets through the DFSMDA member.
- In the sample DCC procedure that is built during SMP/E processing and placed in the ADFSPROC and SDFSPROC library data sets, the IMSMON DD statement is included as a comment. To use the IMSMON DD statement, remove the asterisks (*).

JCL

The following procedure executes an IMS DCCTL address space.

```
//          PROC   RGN=64M,SOUT=A,DPTY=' (14,15) ',
//              SYS=,SYS1=,SYS2=,
//              LOGT=2400,
//              RGSUF=DCC,PARM1=,PARM2=
//IEFPROC EXEC PGM=DFSVMRC0,DPRTY=&DPTY,REGION=&RGN,
//              PARM=' DCC,&RGSUF,&PARM1,&PARM2'
//*
//*****
//* THE DESCRIPTION AND CHARACTERISTICS OF EACH      *
//* PARAMETER IS DEFINED AS FOLLOWS:                 *
//*                                                    *
//*****
//*
//***** CONTROL REGION SPECIFICATIONS *****
//*
//*   RGSUF   XXX   EXEC PARM DEFAULT BLOCK SUFFIX FOR
//*           MEMBER DFSPBXXX.
//*****
//*
//* PARM1 , PARM2 PARAMETERS BOTH ARE USED TO SPECIFY
//* CHARACTER STRINGS THAT CONTAIN IMS KEYWORD
//* PARAMETERS. I.E. PARM1=' AUTO=Y,PST=222,RES=Y'
//*
//* ALL OF THE VALID DCCTL KEYWORD PARAMETERS
```

```

//* ARE DESCRIBED BELOW
//*****
//* APPLID1 XXXXXXXX VTAM APPLID OF ACTIVE IMS SYSTEM
//* APPLID2 XXXXXXXX VTAM APPLID OF XRF ALTERNATE SYSTEM
//* APPLID3 XXXXXXXX VTAM APPLID OF RSR TRACKING SYSTEM
//* RES      X      BLOCK RESIDENT (N = NO, Y = YES)
//* FRE      XXXXX  NUMBER OF FETCH REQUEST ELEMENTS
//* PST      XXX    NUMBER OF PST'S PERMANENTLY ALLOC
//* MAXPST   XXX    MAXIMUM NUMBER OF PST'S
//* SAV      XXX    NUMBER OF DYNAMIC SAVE AREA SETS
//* SRCH     X      IMODULE LOAD LIBRARY SEARCH INDICATOR
//*           0 = SEARCH JPA AND LIBS BEFORE LPA
//*           1 = SEARCH JPA AND LPA BEFORE LIBS
//* SOD      X      SPIN OFF DUMP SYSOUT CLASS
//* VAUT     X      VTAM AUTH PATH OPTION (1=YES,0=NO)
//* FMTO           T = ONLINE FORMATTED DUMP WITH
//*                   STORAGE IMAGE DELETIONS.
//*                   OFFLINE SDUMPS PERMITTED FOR
//*                   NON-IMS TERMINATING ERRORS.
//*                   P = FULL ONLINE FORMATTED DUMP.
//*                   OFFLINE SDUMPS PERMITTED FOR
//*                   NON-IMS TERMINATING ERRORS.
//*                   F = FULL ONLINE FORMATTED DUMP.
//*                   OFFLINE SDUMPS SUPPRESSED FOR
//*                   NON-IMS TERMINATING ERRORS.
//*                   N = NO FORMATTED DUMP, NO OFFLINE
//*                   DUMP. OFFLINE SDUMPS PERMITTED
//*                   FOR NON-IMS TERMINATING ERRORS
//*                   Z = NO FORMATTED DUMP, NO OFFLINE
//*                   DUMP. OFFLINE SDUMPS
//*                   SUPPRESSED FOR NON-IMS
//*                   TERMINATING ERRORS.
//* (DEFAULT) D = OFFLINE DUMP, OR ONLINE FOR-
//*             MATTED DUMP WITH STORAGE IMAGE
//*             DELETIONS IF OFFLINE DUMPING
//*             FAILS. OFFLINE SDUMPS
//*             PERMITTED FOR NON-IMS
//*             TERMINATING ERRORS.
//*             X = OFFLINE DUMP, OR ONLINE FOR-
//*             MATTED DUMP WITH STORAGE IMAGE
//*             DELETIONS IF OFFLINE DUMPING
//*             FAILS. OFFLINE SDUMPS
//*             SUPPRESSED FOR NON-IMS
//*             TERMINATING ERRORS.
//*             M = OFFLINE DUMP, ONLINE IMS DUMP
//*             FORMATTING NOT PERMITTED.
//*             OFFLINE SDUMPS PERMITTED FOR
//*             NON-IMS TERMINATING ERRORS.
//*             R = OFFLINE DUMP, ONLINE IMS DUMP
//*             FORMATTING NOT PERMITTED.
//*             OFFLINE SDUMPS SUPPRESSED FOR
//*             NON-IMS TERMINATING ERRORS.
//* AUTO     X      AUTOMATIC RESTART OPTION
//*           Y = AUTOMATIC RESTART DESIRED
//*           N = NO AUTOMATIC RESTART
//* IMSID    XXXX   IMS DCCTL SUBSYSTEM ID
//* NLXB     XXX    NUMBER OF PARALLEL VTAM SESSIONS
//* APPC     X      Y = ACTIVATE APPC/IMS
//*           N = DO NOT ACTIVATE APPC/IMS
//* LTERM    X      Y = LTERM USED IN DFSAPPC PROCESS
//*           N = LTERM NOT USED IN DFSAPPC
//*           PROCESS
//* ARMST    X      Y = ALLOW MVS ARM TO RESTART
//*           N = ARM NOT RESTART IMS
//* RRS      X      Y = ENABLE PROT CONV SUPPORT
//*           N = DISABLE PROT CONV SUPPORT
//* DBRCNM   XXXXXXXX DBRC PROCLIB MEMBER NAME
//* PRDR     XXXXXXXX IMSRDR PROCLIB MEMBER NAME
//* SSM      XXXX   EXT SUBSYSTEM PROCLIB MEMBER ID
//* RECA     XXX    RECEIVE ANY BUFFERS
//* FESTIM   XXXX   FRONTENDSWITCH TIMEOUT
//* RECASZ   XXXXX  RECEIVE ANY BUFFER SIZE
//* CRC      X      COMMAND RECOGNITION CHARACTER
//* TSR      X      U = UTC TIME
//*           L = LOCAL TIME (DEFAULT)
//* YEAR4    X      N = 2-DIGIT DATE (DEFAULT)
//*           Y = 4-DIGIT DATE
//* DC       XXX    DC PROC MEMBER SUFFIX IN
//*           IMS.PROCLIB
//*           DEFAULT VALUE IS 000
//* CPLOG    XXXXXX CHECKPOINT LOG INTERVAL
//*           OR

```

```

//* CPLOG   XXM   CHECKPOINT LOG INTERVAL
//* PASSWD1 XXXXXXXX VTAM ACB PASSWORD
//* ORSMBR  XX   SUFFIX FOR ORS MEMBER
//* IMSGROUP XXXX 4 CHAR USER SPEC NAME
//* DESC    XX   MSG DESC CODE
//* MCS     (XX,XX) MSG ROUTE CODES
//* SVC2    XXX  TYPE 2 SVC NUMBER
//
//***** OTMA PARAMETERS *****
//
//* OTMA    X    Y = OTMA ENABLED
//              N = OTMA NOT ENABLED
//              DEFAULT VALUE IS N
//* OTMANM  XXXXXXXX IMS OTMA XCF MEMBER NAME
//* GRNAME  XXXXXXXX OTMA XCF GROUP NAME
//              NO DEFAULT VALUE
//* GRSNAME XXXXXXXX GENERIC RESOURCE GROUP
//              NAME
//              NO DEFAULT VALUE
//***** SECURITY PARAMETERS *****
//
//* AOIS    X    ICMD SECURITY OPTION
//* AOI1    X    CMD SECURITY OPTION
//              A = ALL
//              N = NONE
//              C = DFSCCMD0 EXIT
//              R = RACF
//* TCORACF X    TCO RACF SECURITY OPTION
//              Y = YES
//              N = NO
//* APPCSE  X    C = APPC RACF SECURITY IS CHECK
//              F = APPC RACF SECURITY IS FULL
//              N = APPC RACF SECURITY IS NONE
//              P = APPC RACF SECURITY IS PROFILE
//* CMDMCS  X    MCS/EMCS COMMAND OPTION
//              N=COMMANDS NOT ALLOWED WITH CRC
//              Y=ALL COMMANDS ALLOWED WITH CRC
//              R=RACF COMMAND SECURITY
//              C=DFSCCMD0 COMMAND SECURITY
//              B=RACF AND DFSCCMD0 CMD SEC
//* ISIS    X    RAS SECURITY OPTION
//              N = NO RESOURCE ACCESS SECURITY
//              R = RACF RESOURCE ACCESS SECURITY
//              C = RACF RESOURCE ACCESS SECURITY
//              A = RACF RESOURCE ACCESS SECURITY
//* RCF     X    RACF TRAN/CMD AUTHORIZATION
//              N = NO TRAN/CMD AUTHORIZATION
//              C = ETO CMD AUTHORIZATION
//              T = TRAN AUTHORIZATION
//              S = STATIC LTERM CMD AUTH
//              Y = C AND T
//              A = C AND T AND S
//* RVFY    X    RACF REVERIFY OPTION
//              Y = YES, N = NO
//* SGN     X    SIGNON AUTHORIZATION CHECKING
//              F = MTO CANNOT NEGATE ACTIVATION
//              OF SIGNON VERIFICATION
//              SECURITY
//              Y = SIGNON VERIFICATION SECURITY
//              WILL BE ACTIVATED
//              N = SIGNON VERIFICATION SECURITY
//              WILL NOT BE ACTIVATED
//              M = SINGLE USERID CAN SIGNON
//              TO MULTIPLE STATIC TERMINALS
//              G = 'F' + 'M'
//              Z = 'Y' + 'M'
//* TRN     X    TRANSACTION AUTHORIZATION CHECKING
//              F = FORCED, Y = YES, N = NO
//* RCFTCB  XX   NUMBER OF RCF TCB'S
//* PSWDC   X    PASSWORD CASE
//              U=UPPER CASE
//              M=MIXED CASE
//              R=USES RACF SETTING (DEFAULT)
//***** MESSAGE QUEUE PARAMETERS *****
//
//* EXVR    X    PAGEFIX QMGR BUFFER POOLS
//              (1=YES, 0=NO)
//* QBUF    XXXX NUMBER OF MESSAGE QUEUE BUFFERS
//* QTU     XXX  MSG QUEUE UPPER THRESHOLD (%)
//* QTL     XXX  MSG QUEUE LOWER THRESHOLD (%)
//
//***** SHARED QUEUES PARAMETERS *****

```

```

//*
//* LGMSGSZ XXXXX LONG MESSAGE SIZE
//* QBUFHITH XXX MSG QBUF HIGH THESHOLD %
//* QBUFLWTH XXX MSG QBUF LOW THESHOLD %
//* QBUFMAX XXXX MAX NUMBER OF MSG QUEUE BUFFERS
//* QBUFPCTX XXX % MSG QBUF DYNAMIC EXPAND
//* WHEN QBUFHITH EXCEEDED
//* DEFAULT IS 20%
//* QBUFSZ XXXXX SIZE OF MESSAGE QUEUE BUFFERS
//* SHMSGSZ XXXXX SHORT MESSAGE SIZE
//* SHAREDQ XXX SQ PROC MEMBER SUFFIX IN
//* IMS.PROCLIB
//* NO DEFAULT VALUE
//*
//***** MSC PARAMETER *****
//* MSC X ENABLE OR DISABLE MSC IN THIS IMS
//* N: DO NOT INCLUDE MSC.
//* UNLESS MSC RESOURCES ARE DEFINED
//* DURING SYSTEM DEFINITION, MSC=N
//* IS THE DEFAULT.
//* Y: INCLUDE MSC IN THIS IMS.
//*
//***** ETO PARAMETERS *****
//*
//* ETO X Y = EXTENDED TERMINAL OPTION
//* N = NO EXTENDED TERMINAL OPTION
//* M = NO EXTENDED TERMINAL OPTION
//* BUT LOGON USERDATA SUPPORTED
//* FOR STATIC TERMINALS
//* ASOT XXXX ETO AUTO SIGNOFF TIME
//* ALOT XXXX ETO AUTO LOGNOFF TIME
//* DLQT XXX ETO DEAD LETTER QUEUE SIZE
//*
//***** RSR PARAMETERS *****
//*
//* RSRMBR XX SUFFIX FOR RSR MEMBER
//* TRACK XXX NO = NO RECOVERY TRACKING DONE
//* RLT = RECOVERY TRACKING DONE
//* USERVAR XXXXXXXX USER NAME OF ACTIVE IMS SYSTEM FOR RSR
//*
//***** HASH TABLE PARAMETERS *****
//*
//* LHTS XXXXX # OF CNT HASH TABLE SLOTS
//* NHTS XXXXX # OF VTCB HASH TABLE SLOTS
//* UHTS XXXXX # OF SPQB HASH TABLE SLOTS
//***** FAST PATH PARAMETERS *****
//*
//* EPCB XXXX EPCB POOL SIZE (1K BLOCKS)
//* EMHL XXXXX SIZE OF EMH BUFFER IN BYTES
//* FP X INCLUDE FASTPATH IN THIS IMS
//* N: THE DEFAULT. THIS IMS DOES
//* NOT INCLUDE FASTPATH
//* Y: THIS IMS INCLUDES FASTPATH
//*
//***** STORAGE POOL VALUES IN K, M OR G *****
//*
//* FBP XXXXXX MESSAGE FORMAT BLOCK POOL SIZE
//* PSB XXXXXX DCCTL PSB POOL SIZE
//* CIOP XXXXXX TP DEVICE I/O POOL UPPER LIMIT
//* WKAP XXXXXX WORKING STORAGE POOL SIZE
//* PSBW XXXXXX PSB WORK POOL SIZE
//* HIOP XXXXXX HIGH I/O POOL UPPER LIMIT
//* EMHB XXXXXX EMHB POOL UPPER LIMIT
//* LUMP XXXXXX LUMP POOL UPPER LIMIT
//* LUMC XXXXXX LUMC POOL UPPER LIMIT
//* DYNP XXXXXX DYNP POOL UPPER LIMIT
//* AOIP XXXXXX AOI POOL UPPER LIMIT
//* CMDP XXXXXX CMDP POOL UPPER LIMIT
//*
//***** MEMBER SUFFIXES *****
//*
//* SUF X CONTROL PGM NAME (DCCTL NUCLEUS)
//* FIX XX PAGE FIX NAME (DFSFIX..)
//* PRLD XX MODULE PRELOAD NAME (DFSAMPL..)
//* VSPEC XX TRACE/LOG DEF (DFSISM..)
//* SPM XX STORAGE POOL OPTIONS (DFSSPM..)
//* CSLG XXX CSL GLOBAL MEMBER (DFSCGXXX)
//* DSCT X ETO USER DESCRIPTOR TABLE (DFSDSCTX)
//* DFSDF XXX DRD, CSL, AND SQ MEMBER (DFSDFXXX)
//*
//***** XRF PARAMETERS *****
//*
```



```

//* HSBID X XRF SYSTEM IDENTIFICATION
//* 1 FOR FIRST SYSTEM
//* 2 FOR SECOND SYSTEM
//* HSBMBR XX XRF OPTIONS (DFSHSB..)
//*
//* MNPS XXXXXXXX NAME OF MNPS ACB
//* USERVAR WILL BE IGNORED
//* MNPSPW XXXXXXXX MNPS ACB PASSWORD
//*****
//* XRF SYSTEM DATA SET INFORMATION *
//*****
//* THE FOLLOWING DATA SETS MUST RESIDE ON SHARED
//* VOLUMES:
//*
//* DDNAMES: DFSOLPXX, DFSOLSXX
//* DFSWADSX
//* IMSRDS - FIRST RDS
//* IMSRDS2 - SECOND RDS (MANDATORY)
//* MODSTAT - FIRST MODSTAT
//* MODSTAT2 - 2ND MODSTAT (MANDATORY)
//* RECON1, RECON2, RECON3
//*
//* THE FOLLOWING DATA SETS MUST BE REPLICATED AND
//* SHOULD BE ON NON-SHARED VOLUMES. IF YOUR XRF
//* CONFIGURATION REQUIRES THAT BOTH IMS SUBSYSTEMS
//* BE EXECUTABLE ON EITHER CEC, THEN THESE DATA
//* SETS MUST BE ON SHARED VOLUMES.
//*
//* DDNAMES: IMSSPA
//* LGMSG, LGMSG1
//* QBLKS, QBLKSL
//* SHMSG, SHMSG1
//*
//* SYSABEND, SYSUDUMP
//* IMSMON
//*
//* THE FOLLOWING DATA SETS MAY BE REPLICATED. IF
//* REPLICATED, THESE DATA SETS SHOULD BE ON
//* NON-SHARED VOLUMES. IF THESE DATA SETS ARE NOT
//* REPLICATED, THEY MUST BE ON SHARED VOLUMES. IF
//* YOUR XRF CONFIGURATION REQUIRES THAT BOTH IMS
//* SUBSYSTEMS BE EXECUTABLE ON EITHER CEC,
//* THESE DATA SETS MUST BE ON SHARED VOLUMES.
//*
//* DDNAMES: FORMATA, FORMATB
//* IMSACBA, IMSACBB
//* IMSTFMTA, IMSTFMTB
//* MODBLKSA, MODBLKSB
//* PROCLIB, RESLIB
//* OTHER STEPLIB DATA SETS
//* THE FOLLOWING DATA SETS SHOULD ALSO BE CONSIDERED
//* FOR REPLICATION ON EITHER SHARED OR NON-SHARED
//* VOLUMES (AS APPROPRIATE).
//*
//* DATA SET: JOBS USED IN THE IMSRDR PROCEDURE
//* PGMLIB
//* PSBLIB USED BY GSAM
//* DBDLIB USED BY GSAM
//*
//* THE FOLLOWING IMS DATA SETS MAY ALSO BE IMPACTED
//* BY THE CONFIGURATION OF YOUR XRF COMPLEX.
//*
//* INSTALIB - USED DURING INSTALLATION/IVP
//* RESLIB - CREATED BY SYSDEF - MANAGED BY SMP
//* PROCLIB - CREATED BY SYSDEF
//* MACLIB - CREATED BY SYSDEF - MANAGED BY SMP
//* OPTIONS - CREATED BY SYSDEF - USED BY SMP
//* OBJDSET - CREATED BY SYSDEF
//* MODBLKS - CREATED BY SYSDEF - MANAGED BY SMP
//* ACBLIB - ONLINE CHANGE STAGING LIBRARY
//* FORMAT - ONLINE CHANGE STAGING LIBRARY
//* TFORMAT - ONLINE CHANGE STAGING LIBRARY
//* REFERAL - USED IN CONJUNCTION WITH FORMAT
//* DBSOURCE - USED BY SYSDEF - MANAGED BY SMP
//* DCSOURCE - USED BY SYSDEF - MANAGED BY SMP
//* SRSOURCE - USED BY SYSDEF - MANAGED BY SMP
//* ADFSMAC - USED BY SYSDEF - MANAGED BY SMP
//* LOAD - USED BY SYSDEF - MANAGED BY SMP
//* JCLLIB - MANAGED BY SMP

```

```

//* SMP DATA SETS
//*
//*****
//*
//*          DATA DEFINITION STATEMENTS FOLLOW          *
//*
//*****
//***** LIBRARY STATEMENTS *****
//*
//STEPLIB DD DSN=IMS.&SYS2.SDFSRESL,DISP=SHR
//PROCLIB DD DSN=IMS.&SYS2.PROCLIB,DISP=SHR
//*
//*****
//*
//* IN ORDER TO START A DEPENDENT REGION, MODIFIED
//* START-UP JCL IS WRITTEN FROM INTERNAL STORAGE TO
//* THE INTERNAL READER.
//*
//IMSIRD DD SYSOUT=(A,INTRDR)
//*
//*
//*
//***** MONITOR LOGGING STATEMENTS *****
//*
//* THE IMSMON DD STATEMENT MUST BE REMOVED IF
//* THIS DATA SET IS TO BE DYNAMICALLY ALLOCATED.
//*
//IMSMON DD DSN=IMS.&SYS1.IMSMON,DISP=(,KEEP),
// VOL=(,,99),UNIT=(&LOGT,,DEFER)
//*
//***** MESSAGE QUEUE STATEMENTS *****
//*
//QBLKS DD DSN=IMS.&SYS1.QBLKS,DISP=OLD
//SHMSG DD DSN=IMS.&SYS1.SHMSG,DISP=OLD
//LGMSG DD DSN=IMS.&SYS1.LGMSG,DISP=OLD
//QBLKSL DD DSN=IMS.&SYS1.QBLKSL,DISP=OLD
//SHMSGSL DD DSN=IMS.&SYS1.SHMSGSL,DISP=OLD
//LGMSGSL DD DSN=IMS.&SYS1.LGMSGSL,DISP=OLD
//*
//***** ONLINE CHANGE STATEMENTS *****
//* THE IMSACBA AND IMSACBB DD STATEMENTS MUST BE
//* REMOVED IF YOU WISH TO DYNAMICALLY ALLOCATE THE
//* ACBLIB DATA SETS THROUGH THE DFSMDA MEMBER.
//*
//IMSACBA DD DSN=IMS.&SYS2.ACBLIBA,DISP=SHR
//IMSACBB DD DSN=IMS.&SYS2.ACBLIBB,DISP=SHR
//MODBLKSA DD DSN=IMS.&SYS2.MODBLKSA,DISP=SHR
//MODBLKSB DD DSN=IMS.&SYS2.MODBLKSB,DISP=SHR
//MODSTAT DD DSN=IMS.&SYS2.MODSTAT,DISP=SHR
//MODSTAT2 DD DSN=IMS.&SYS2.MODSTAT2,DISP=SHR
//*
//***** MFS STATEMENTS *****
//*
//FORMATA DD DSN=IMS.&SYS2.FORMATA,DISP=SHR
//FORMATB DD DSN=IMS.&SYS2.FORMATB,DISP=SHR
//IMSTFMTA DD DSN=IMS.&SYS2.TFORMAT,DISP=SHR
//
// DD DSN=IMS.&SYS2.FORMATA,DISP=SHR
//IMSTFMTB DD DSN=IMS.&SYS2.TFORMAT,DISP=SHR
//
// DD DSN=IMS.&SYS2.FORMATB,DISP=SHR
//*
//***** DCCTL SYSTEM STATEMENTS *****
//*
//IMSRDS DD DSN=IMS.&SYS.RDS,DISP=SHR
//IMSRDS2 DD DSN=IMS.&SYS.RDS2,DISP=SHR
//*DFSTCF DD DSN=IMS.TCFSLIB,DISP=SHR
//PRINTDD DD SYSOUT=&SOUT
//SYSUDUMP DD SYSOUT=&SOUT,
// DCB=(LRECL=125,RECFM=FBA,BLKSIZE=3129),
// SPACE=(6050,300,,ROUND)
//*
//***** TELEPROCESSING LINE STATEMENTS *****
//***** GENERATED FROM DCCTL DEFINITION *****
//*
//* *** THE GENERATED TELEPROCESSING LINE STATEMENTS WOULD BE HERE ***
//*
//***** EXTERNAL SUBSYSTEM STATEMENTS *****
//*
//* INCLUDE THE DFSESL DD STATEMENT IF AN EXTERNAL
//* SUBSYSTEM CONNECTION TO DB2 IS DESIRED.

```

DFSASNO procedure

DFSASNO is a sample procedure that invokes the IMS abend search and notification function, a diagnostic tool that you can customize so that you receive an informational email if an abend occurs.

Before you can use the DFSASNO procedure, you must tailor it, create and populate input data sets for it to use, and perform the IMS abend search and notification setup tasks described in [“Setting up the IMS abend search and notification function”](#) on page 348.

JCL

The JCL and SMTP control statements to invoke IMS abend and search and notification follow.

```
//*****  
//* DFSASNO  
//* NOTE: THIS MEMBER MUST BE COPIED TO  
//* A CONCATENATED Z/OS PROCEDURE LIBRARY  
//* FOR THE EVENT-DRIVEN ACTIVATION  
//*****  
//DFSASNO PROC  
// PARM1=,PARM2=  
//*  
//*****  
//* REMOVE THE EMAIL DATA SET IF IT EXISTS  
//*****  
//IASN1 EXEC PGM=IEFBR14  
//LSTEMAIL DD DSN=USERID.IASN.SDFSSWAN.LSTEMAIL,  
// DCB=(LRECL=255,BLKSIZE=2550,RECFM=FB),  
// DISP=(MOD,DELETE), UNIT=SYSDA,  
// SPACE=(TRK,(1,1))  
//*  
//*****  
//* REMOVE THE SMS DATA SET IF IT EXISTS  
//*****  
//IASN1B EXEC PGM=IEFBR14  
//LSTSMS DD DSN=USERID.IASN.SDFSSWAN.LSTSMS,  
// DCB=(LRECL=255,BLKSIZE=2550,RECFM=FB),  
// DISP=(MOD,DELETE),  
// UNIT=SYSDA,  
// SPACE=(TRK,(1,1))  
//*  
//*****  
//* WRITE THE FORMATTED EMAIL OUT TO EMAIL DATA SET  
//*****  
//IASN2 EXEC PGM=DFSASNP,PARM='&PARM1;,&PARM2;'  
// STEPLIB DD DISP=SHR,DSN=STLSERV.QPPTTEST.IMS.SDFSRESL  
// SYSUT1 DD DISP=SHR,DSN=RUNTIME.DS(DFSIAEML)  
// URLS DD DISP=SHR,DSN=RUNTIME.DS(DFSIAURL)  
// CONTROL DD DISP=SHR,DSN=RUNTIME.DS(DFSIACTL)  
// INPARMS DD DISP=SHR,DSN=SKELETON.DS(DFSIAPRM)  
// SYSPRINT DD SYSOUT=*  
// SYSUT2 DD DSN=*.IASN1.LSTEMAIL,DISP=(NEW,CATLG),  
// DCB=(LRECL=255,BLKSIZE=2550,RECFM=FB),  
// UNIT=SYSDA,SPACE=(TRK,(1,1))  
//*  
//*****  
//* WRITE THE FORMATTED SMS OUT TO SMS DATA SET  
//*****  
//IASN2B EXEC PGM=DFSASNP,PARM='&PARM1;,&PARM2;'  
// STEPLIB DD DISP=SHR,DSN=STLSERV.QPPTTEST.IMS.SDFSRESL  
// SYSUT1 DD DISP=SHR,DSN=RUNTIME.DS(DFSIASMS)  
// URLS DD DISP=SHR,DSN=RUNTIME.DS(DFSIAURL)  
// CONTROL DD DISP=SHR,DSN=RUNTIME.DS(DFSIACTST)  
// INPARMS DD DISP=SHR,DSN=SKELETON.DS(DFSIAPRM)  
// SYSPRINT DD SYSOUT=*  
// SYSUT2 DD DSN=*.IASN1B.LSTSMS,DISP=(NEW,CATLG),  
// DCB=(LRECL=255,BLKSIZE=2550,RECFM=FB),  
// UNIT=SYSDA,SPACE=(TRK,(1,1))  
//*  
//*****  
//* SENDS FORMATTED EMAIL OUT THROUGH THE Z/OS SMTP  
//*****  
//IASN3 EXEC PGM=IEBGENER  
// SYSUT1 DD DISP=SHR,DSN=*.IASN1.LSTEMAIL  
// SYSUT2 DD SYSOUT=(B,SMTP),DCB=(LRECL=255,BLKSIZE=2550,RECFM=FB)  
// SYSPRINT DD SYSOUT=*  
// SYSIN DD DUMMY
```

```

// *
// *****
// * SENDS FORMATTED SMS OUT THROUGH THE Z/OS SMTP
// *****
// IASN3B EXEC PGM=IEBGENER
//     SYSUT1 DD DISP=SHR,DSN=*.IASN1B.LSTSMS
//     SYSUT2 DD SYSOUT=(B,SMTP),DCB=(LRECL=255,BLKSIZE=2550,RECFM=FB)
//     SYSPRINT DD SYSOUT=*
//     SYSIN DD DUMMY
// *
// *****
// * Steps IASN3 and IASN3B if external SMTP server
// * is specified on "System Setup" panel:
// *****
// * SENDS FORMATTED EMAIL OUT THROUGH EXTERNAL SMTP
// *****
// IASN3 EXEC PGM=IRXJCL,PARM='DFSASNT SMTPHOST.COMPANY.COM 25'
//     SYSEXEC DD DISP=SHR,DSN=STLSERV.QPPTEST.IMS.SDFSEXEC
//     SYSTSIN DD DUMMY
//     SYSTSPRT DD SYSOUT=*,DCB=LRECL=256
//     SYSTIN DD DUMMY
//     TELOUT DD SYSOUT=*,DCB=LRECL=256
//     TELIN DD DISP=SHR,DSN=*.IASN1.LSTEMAIL
// *
// *****
// * SENDS FORMATTED SMS OUT THROUGH EXTERNAL SMTP
// *****
// IASN3B EXEC PGM=IRXJCL,PARM='DFSASNT SMTPHOST.COMPANY.COM 25'
//     SYSEXEC DD DISP=SHR,DSN=STLSERV.QPPTEST.IMS.SDFSEXEC
//     SYSTSIN DD DUMMY
//     SYSTSPRT DD SYSOUT=*,DCB=LRECL=256
//     SYSTIN DD DUMMY
//     TELOUT DD SYSOUT=*,DCB=LRECL=256
//     TELIN DD DISP=SHR,DSN=*.IASN1B.LSTSMS
// *

```

Usage

There are several job steps in DFSIASN0:

- Steps IASN1 and IASN1B clean up the data sets that are used for each invocation of the IMS abend and search and notification function.
- Steps IASN2 and IASN2B parse the parameter string and create the email or text message to be sent.
- Steps IASN3 and IASN3B send the email message and the text message using either the z/OS SMTP server or an external SMTP server, depending on which server is specified during the system setup.

Parameters

PARM1= and PARM2= represent a character string that is passed to the DFSIASN0 procedure either from:

- System setup during an abend invocation
- JCL run deck during an on-demand invocation

This character string contains the input parameters that are passed to the IMS abend search and notification parsing module. The following input parameters can be used with the DFSIASN0 procedure:

```

ABND=
APAR=
FMID=
GEN=
IMS=
MOD=
MSG=
RC=
SYSID=
T=

```

For descriptions of these parameters, see [“Parameter descriptions for IMS procedures”](#) on page 520.

DD statements

The following DD statements can be used with the DFSIASN0 procedure.

CONTROL DD
INPARMS DD
SYSUT1 DD
SYSUT2 DD
SYSPRINT DD
URLS DD

For descriptions of these DD statements, see [“DD statements for IMS procedures”](#) on page 583.

DFSJBP procedure

The DFSJBP procedure starts a Java non-message-driven dependent region that resembles a non-message-driven BMP region (for example, similar procedure parameters and z/OS TCB structure).

The DFSJBP procedure resides in the IMS PROCLIB data set as a standard IMS system definition-supplied procedure and can be invoked as the IMSBATCH procedure is invoked.

The procedure shown in [“Procedure to start a JBP region”](#) on page 622 starts a JBP region.

Usage

The DFSJVMAP member of the IMS PROCLIB data set can be used with a DFSJBP procedure. DFSJVMAP maps all the 8-byte or less uppercase Java application names (specified to IMS) to the true OMVS path name for the ".class" file associated with that Java application. For more information, see [“DFSJVMAP member of the IMS PROCLIB data set”](#) on page 840.

Parameters

The following parameters are valid for the DFSJBP procedure.

AGN=
ALTID=
APARM=
CKPTID=
CPUTIME=
CSSLIB=
DIRCA=
ENVIRON=
IMSID=
JVM=
JVMOPMAS=
LOCKMAX=
MBR=
NBA=
NODE1=
NODE2=
OBA=
OPT=
OUT=
PARDLI=
PREINIT=
PRLD=
PSB=

RGN=
SCEERUN=
SOUT=
SPIE=
SSM=
SYS2=
TEST=

See [“Parameter descriptions for IMS procedures” on page 520](#) for parameter descriptions.

DD statements

The following DD statements are valid for the DFSJBP procedure.

DFSDB2AF DD
DFSESL DD (optional)
JAVAERR DD
JAVAOUT DD
PROCLIB DD
STDENV DD
STDIN DD
STEPLIB DD
SYSUDUMP DD

See [“DD statements for IMS procedures” on page 583](#) for descriptions.

Restrictions

- Only a Java application can be scheduled in this region.
- The JVMOPMAS=<member name> sets the name of the member of the IMS PROCLIB data set that contains the JVM options for the master JVM, and is required. However, when the //STDENV DD statement is used, this parameter is ignored.
- The ENVIRON= parameter, which specifies the name of the PROCLIB member that contains the environment settings, is a required parameter. However, when the //STDENV DD statement is used, this parameter is ignored.
- The existing IN= parameters on the IMSBATCH procedure are not supported on the DFSJBP procedure.
- For access to Db2 for z/OS, the Db2 Resource Recovery Services attachment facility (RRSAF) remains the default connection method. The SSM= parameter is required if the external subsystem attach facility (ESAF) is the connection method to an external subsystem such as Db2 for z/OS.
- Do not switch to JVM=64 if your Java application invokes either COBOL or PL/I. The Language Environment does not support COBOL and PL/I interoperability in a 64-bit addressing mode. For more information, see [Language environments \(Application Programming\)](#).

Procedure to start a JBP region

```
//JBPJOB   JOB 1,IMS,MSGLEVEL=1,PRTY=11,CLASS=K,MSGCLASS=A,REGION=56K
//        EXEC DFSJBP,
//        IMSID=

//        PROC MBR=TEMPNAME,PSB=,JVMOPMAS=,OUT=,
//        OPT=N,SPIE=0,TEST=0,DIRCA=000,
//        STIMER=,CKPTID=,PARDLI=,
//        CPUTIME=,NBA=,OBA=,IMSID=,AGN=,
//        PREINIT=,RGN=56K,SOUT=A,
//        SYS2=,ALTID=,APARM=,ENVIRON=,LOCKMAX=,
//        PRLD=,SSM=,JVM=31
//*
//JBPRGN EXEC PGM=DFSRR00,REGION=&RGN,
```

```

//          PARM=(JBP,&MBR,&PSB,&JVMOPMAS,&OUT,
//          &OPT&SPIE&TEST&DIRCA,
//          &STIMER,&CKPTID,&PARDLI,&CPUTIME,
//          &NBA,&OBA,&IMSID,&AGN,
//          &PREINIT,&ALTID,
//          '&APARM',&ENVIRON,&LOCKMAX,
//          &PRLD,&SSM,&JVM)
//STEPLIB DD DSN=IMS.&SYS2.SDFSJLIB,DISP=SHR
//          DD DSN=IMS.&SYS2.SDFSRESL,DISP=SHR
//          DD DSN=IMS.&SYS2.PGMLIB,DISP=SHR
//          DD DSN=CEE.SCEERUN,DISP=SHR
//          DD DSN=SYS1.CSSLIB,DISP=SHR
//PROCLIB DD DSN=IMS.&SYS2.PROCLIB,DISP=SHR
//SYSUDUMP DD SYSOUT=&SOUT,
//          DCB=(LRECL=121,RECFM=VBA,BLKSIZE=3129),
//          SPACE=(125,(2500,100),RLSE,,ROUND)

```

Sample procedure to start a JBP region with JVM=3164

```

//JBPJOB JOB 1,IMS,MSGLEVEL=1,PRTY=11,CLASS=K,MSGCLASS=A,REGION=56K
// EXEC DFSJBP,
//      IMSID=
//      PROC MBR=TEMPNAME,PSB=,JVMOPMAS=,OUT=,
//          OPT=N,SPIE=0,TEST=0,DIRCA=000,
//          STIMER=,CKPTID=,PARDLI=,
//          CPUTIME=,NBA=,OBA=,IMSID=,AGN=,
//          PREINIT=,RGN=56K,SOUT=A,
//          SYS2=,ALTID=,APARM=,ENVIRON=,LOCKMAX=,
//          PRLD=,SSM=,JVM=3164
//*
//JBPRGN EXEC PGM=DFSRR00,REGION=&RGN,
//          PARM=(JBP,&MBR,&PSB,&JVMOPMAS,&OUT,
//          &OPT&SPIE&TEST&DIRCA,
//          &STIMER,&CKPTID,&PARDLI,&CPUTIME,
//          &NBA,&OBA,&IMSID,&AGN,
//          &PREINIT,&ALTID,
//          '&APARM',&ENVIRON,&LOCKMAX,
//          &PRLD,&SSM,&JVM)
//STEPLIB DD DSN=IMS.&SYS2.SDFSJLIB,DISP=SHR
//          DD DSN=IMS.&SYS2.SDFSRESL,DISP=SHR
//          DD DSN=IMS.&SYS2.PGMLIB,DISP=SHR
//          DD DSN=CEE.SCEERUN,DISP=SHR
//          DD DSN=SYS1.CSSLIB,DISP=SHR
//PROCLIB DD DSN=IMS.&SYS2.PROCLIB,DISP=SHR
//SYSUDUMP DD SYSOUT=&SOUT,
//          DCB=(LRECL=121,RECFM=VBA,BLKSIZE=3129),
//          SPACE=(125,(2500,100),RLSE,,ROUND)

```

DFSJMP procedure

The DFSJMP procedure starts a Java message-driven dependent region that resembles an MPP region (for example, similar procedure parameters and z/OS TCB structure).

The DFSJMP procedure resides in the IMS PROCLIB data set as a standard IMS System Definition-supplied procedure and can be invoked as DFSMPR would be invoked.

The procedure shown in [“Sample procedure to start a JMP region”](#) on page 625 starts a JMP region.

Usage

The DFSJVMAP member of the IMS PROCLIB data set can be used with a DFSJMP procedure. DFSJVMAP maps all the 8-byte or less uppercase Java application names (specified to IMS) to the true OMVS path name for the ".class" file associated with that Java application. For more information, see [“DFSJVMAP member of the IMS PROCLIB data set”](#) on page 840.

Parameters

The following parameters are valid for the DFSJMP procedure.

```

AGN=
ALTID=

```

APARM=
CL1=, CL2=, CL3=, CL4=
CSSLIB=
ENVIRON=
IMSID=
JVM=
JVMOPMAS=
LOCKMAX=
MAXTHRD=
MINTHRD=
NBA=
NODE1=
NODE2=
OBA=
OPT=
OVLA=
PARDLI=
PCB=
PRLD=
PREINIT=
PWFI=
RGN=
SCEERUN
SOD=
SOUT=
SPIE=
SSM=
STIMER=
SYS2=
TLIM=
VALCK=

See [“Parameter descriptions for IMS procedures” on page 520](#) for descriptions.

DD statements

The following DD statements are valid for the DFSJMP procedure.

DFSDB2AF DD
DFSESL DD (optional)
JAVAERR DD
JAVAOUT DD
PROCLIB DD
STDENV DD
STDIN DD
STEPLIB DD
SYSUDUMP DD

See [“DD statements for IMS procedures” on page 583](#) for descriptions.

Restrictions

- The JMP region can schedule only a Java application.

- The JVMOPMAS=<member name> sets the name of the member of the IMS PROCLIB data set that contains the JVM options for the master JVM, and is required. However, when the //STDENV DD statement is used, this parameter is ignored.
- The ENVIRON= parameter specifies the name of the member of the IMS PROCLIB data set that contains the environment settings, and is required. However, when the //STDENV DD statement is used, this parameter is ignored.
- The existing APPLFE=, DBLDL=, VSFX=, and VFREE= parameters on the DFSMPR procedure are not supported on the DFSJMP procedure.
- For access to Db2 for z/OS, the Db2 Resource Recovery Services attachment facility (RRSAF) remains the default connection method. The SSM= parameter is required if the external subsystem attach facility (ESAF) is the connection method to an external subsystem such as Db2 for z/OS.
- Do not switch to JVM=64 if your Java application invokes either COBOL or PL/I. The Language Environment does not support COBOL and PL/I interoperability in a 64-bit addressing mode. For more information, see [Language environments \(Application Programming\)](#).
- When the JVM= parameter is specified, all positional parameters that precede JVM= must be explicitly specified.

Sample procedure to start a JMP region

```
//      PROC SOUT=A, RGN=56K, SYS2=,
//      CL1=001, CL2=000, CL3=000, CL4=000,
//      OPT=N, OVLA=0, SPIE=0, VALCK=0, TLIM=00,
//      PCB=000, STIMER=, SOD=,
//      NBA=, OBA=, IMSID=, AGN=,
//      PREINIT=, ALTID=, PWFI=N, APARM=,
//      LOCKMAX=, ENVIRON=,
//      JVMOPMAS=, PRLD=, SSM=, PARDLI=,
//      MINTHRD=000, MAXTHRD=256, JVM=31
// *
//JMPRGN EXEC PGM=DFSRRC00, REGION=&RGN,
//      TIME=1440, DPRTY=(12, 0),
//      PARM=(JMP, &CL1&CL2&CL3&CL4,
//      &OPT&OVLA&SPIE&VALCK&TLIM&PCB,
//      &STIMER, &SOD, &NBA,
//      &OBA, &IMSID, &AGN, &PREINIT,
//      &ALTID, &PWFI, ' &APARM ', &LOCKMAX,
//      &ENVIRON, , &JVMOPMAS, &PRLD, &SSM, &PARDLI,
//      &MINTHRD, &MAXTHRD, &JVM)
// *
//STEPLIB DD DSN=IMS.&SYS2.PGMLIB, DISP=SHR
//      DD DSN=IMS.&SYS2.SDFSJLIB, DISP=SHR
//      DD DSN=IMS.&SYS2.SDFSRESL, DISP=SHR
//      DD DSN=CEE.SCEERUN, DISP=SHR
//      DD DSN=SYS1.CSSLIB, DISP=SHR
//PROCLIB DD DSN=IMS.&SYS2.PROCLIB, DISP=SHR
//SYSUDUMP DD SYSOUT=&SOUT,
//      DCB=(LRECL=121, BLKSIZE=3129, RECFM=VBA),
//      SPACE=(125, (2500, 100), RLSE, , ROUND)
```

Sample procedure to start a JMP region with JVM=3164

```
//      PROC SOUT=A, RGN=56K, SYS2=,
//      CL1=001, CL2=000, CL3=000, CL4=000,
//      OPT=N, OVLA=0, SPIE=0, VALCK=0, TLIM=00,
//      PCB=000, STIMER=, SOD=,
//      NBA=, OBA=, IMSID=, AGN=,
//      PREINIT=, ALTID=, PWFI=N, APARM=,
//      LOCKMAX=, ENVIRON=,
//      JVMOPMAS=, PRLD=, SSM=, PARDLI=,
//      MINTHRD=000, MAXTHRD=256, JVM=3164
// *
//JMPRGN EXEC PGM=DFSRRC00, REGION=&RGN,
//      TIME=1440, DPRTY=(12, 0),
//      PARM=(JMP, &CL1&CL2&CL3&CL4,
//      &OPT&OVLA&SPIE&VALCK&TLIM&PCB,
//      &STIMER, &SOD, &NBA,
//      &OBA, &IMSID, &AGN, &PREINIT,
//      &ALTID, &PWFI, ' &APARM ', &LOCKMAX,
//      &ENVIRON, , &JVMOPMAS, &PRLD, &SSM, &PARDLI,
```

```

//          &MINTHRD , &MAXTHRD , &JVM)
// *
// STEPLIB DD DSN=IMS . &SYS2 . PGMLIB , DISP=SHR
//          DD DSN=IMS . &SYS2 . SDFSJLIB , DISP=SHR
//          DD DSN=IMS . &SYS2 . SDFSRESL , DISP=SHR
//          DD DSN=CEE . SCEERUN , DISP=SHR
//          DD DSN=SYS1 . CSSLIB , DISP=SHR
// PROCLIB DD DSN=IMS . &SYS2 . PROCLIB , DISP=SHR
// SYSUDUMP DD SYSOUT=&SOUT ,
//          DCB=(LRECL=121 , BLKSIZE=3129 , RECFM=VBA) ,
//          SPACE=(125 , (2500 , 100) , RLSE , , ROUND)

```

DFSMPR procedure

The DFSMPR procedure is an online execution procedure that initiates an IMS message processing address space.

The procedure shown in [“Sample procedure to execute an IMS message processing address space”](#) on [page 627](#) executes an IMS message processing address space.

Parameters

The following parameters are valid for the DFSMPR procedure.

AGN=
 ALTID=
 APARM=
 APPLFE=
 CL1=, CL2=, CL3=, CL4=
 DBLDL=
 ENVIRON=
 IMSID=
 JVM=
 JVMOPMAS=
 LOCKMAX=
 NBA=
 NODE1=
 NODE2=
 OBA=
 OPT=
 OVLA=
 PARDLI=
 PCB=
 PREINIT=
 PRLD=
 PWFI=
 RGN=
 SOD=
 SOUT=
 SPIE=
 SSM=
 STIMER=
 SYS2=
 TLIM=
 VALCK=
 VFREE=
 VSFX=

See [“Parameter descriptions for IMS procedures”](#) on page 520 for descriptions.

DD statements

The following DD statements are valid for the DFSMPR procedure.

```
DFSESL DD (optional)
FPTRACE DD (optional)
PROCLIB DD
STDENV DD
STEPLIB DD
SYSUDUMP DD
```

See [“DD statements for IMS procedures”](#) on page 583 for descriptions.

Sample procedure to execute an IMS message processing address space

```
//      PROC SOUT=A,RGN=56K,SYS2=,
//      CL1=001,CL2=000,CL3=000,CL4=000,
//      OPT=N,OVLA=0,SPIE=0,VALCK=0,TLIM=00,
//      PCB=000,PRLD=,STIMER=,SOD=,DBLDL=,
//      NBA=,OBA=,IMSID=,AGN=,VSFX=,VFREE=,
//      SSM=,PREINIT=,ALTID=,PWFI=N,
//      APARM=,LOCKMAX=,APPLFE=,ENVIRON=,
//      JVMOPMAS=,PARDLI=,JVM=
//      /*
//REGION EXEC PGM=DFSRR00,REGION=&RGN,
//      TIME=1440,DPRTY=(12,0),
//      PARM=(MSG,&CL1&CL2&CL3&CL4,
//      &OPT&OVLA&SPIE&VALCK&TLIM&PCB,
//      &PRLD,&STIMER,&SOD,&DBLDL,&NBA,
//      &OBA,&IMSID,&AGN,&VSFX,&VFREE,
//      &SSM,&PREINIT,&ALTID,&PWFI,
//      '&APARM',&LOCKMAX,&APPLFE,
//      &ENVIRON,&JVMOPMAS,&PARDLI,&JVM)
//      /*
//STEPLIB DD DSN=IMS.&SYS2.PGMLIB,DISP=SHR
//      DD DSN=IMS.&SYS2.SDFSRESL,DISP=SHR
//PROCLIB DD DSN=IMS.&SYS2.PROCLIB,DISP=SHR
//SYSUDUMP DD SYSOUT=&SOUT,
//      DCB=(LRECL=121,BLKSIZE=3129,RECFM=VBA),
//      SPACE=(125,(2500,100),RLSE,,ROUND)
```

Sample procedure to execute an IMS message processing address space with JVM=3164

```
//      PROC SOUT=A,RGN=56K,SYS2=,
//      CL1=001,CL2=000,CL3=000,CL4=000,
//      OPT=N,OVLA=0,SPIE=0,VALCK=0,TLIM=00,
//      PCB=000,PRLD=,STIMER=,SOD=,DBLDL=,
//      NBA=,OBA=,IMSID=,AGN=,VSFX=,VFREE=,
//      SSM=,PREINIT=,ALTID=,PWFI=N,
//      APARM=,LOCKMAX=,APPLFE=,ENVIRON=,
//      JVMOPMAS=,PARDLI=,JVM=3164
//      /*
//REGION EXEC PGM=DFSRR00,REGION=&RGN,
//      TIME=1440,DPRTY=(12,0),
//      PARM=(MSG,&CL1&CL2&CL3&CL4,
//      &OPT&OVLA&SPIE&VALCK&TLIM&PCB,
//      &PRLD,&STIMER,&SOD,&DBLDL,&NBA,
//      &OBA,&IMSID,&AGN,&VSFX,&VFREE,
//      &SSM,&PREINIT,&ALTID,&PWFI,
//      '&APARM',&LOCKMAX,&APPLFE,
//      &ENVIRON,&JVMOPMAS,&PARDLI,&JVM)
//      /*
//STEPLIB DD DSN=IMS.&SYS2.PGMLIB,DISP=SHR
//      DD DSN=IMS.&SYS2.SDFSJLIB,DISP=SHR
//      DD DSN=IMS.&SYS2.SDFSRESL,DISP=SHR
//PROCLIB DD DSN=IMS.&SYS2.PROCLIB,DISP=SHR
//SYSUDUMP DD SYSOUT=&SOUT,
//      DCB=(LRECL=121,BLKSIZE=3129,RECFM=VBA),
//      SPACE=(125,(2500,100),RLSE,,ROUND)
```

DLIBATCH procedure

Use the DLIBATCH procedure to enable DL/I batch jobs to run.

When using the DLIBATCH procedure, be aware that:

- As implied by the absence of IMSDALIB from the list of valid DD statements for the DLIBATCH procedure, IMSDALIB is not supported in batch mode.
- In IMS systems that use ACB libraries, if the batch application program will process a HALDB database for which a HALDB alter operation was started but the online change function is not yet done, the IMS DD statement in the DLIBATCH procedure must specify the DBD library that contains the original, unaltered DBD. The IMS DD statement must specify the original DBD regardless of the fact that some or all of the segments in the database might now conform to the format defined by the altered DBD. IMS automatically gets the altered DBD information from the staging ACB library, but requires the original, unaltered DBD for comparison.

[“Procedure for an offline DL/I batch processing program using PSB and DBD libraries” on page 630](#) shows a one-step procedure for an offline DL/I batch processing program using PSB and DBD libraries.

If the IMS management of ACBs is enabled, the offline DL/I batch processing program retrieves the PSB and DBD information from the IMS catalog instead of the PSB and DBD libraries. Any specification of the IMS DD statements is ignored and can be omitted from the JCL.

The enablement of the IMS management of ACBs is determined by the ACBMGMT= parameter in the <CATALOG> section of the DFSDFxxx PROCLIB member or it can be indicated in a batch environment by turning the DXPL_FUNDIREN flag on in the DXPL_FUNCV2 byte in the IMS Catalog Definition exit routine (DFS3CDX0).

If VSAM databases are used, refer to [“IMS buffer pools” on page 206](#).

Usage

In the sample DLIBATCH procedure that is built during SMP/E processing and placed in the ADFSPROC and SDFSPROC library data sets, the IEFRDER2 DD statement is included as a comment. To use the IEFRDER2 DD statement, remove the asterisks (*).

In the example shown in [“Procedure for an offline DL/I batch processing program using PSB and DBD libraries” on page 630](#):

- Parameters in parentheses are positional.
- The IEFRDER statement is not required in DB/DC or DBCTL environments if the job does not declare database update intent.

For a job step declaring database-update intent, DD DUMMY can be specified if the job step is not using DBRC. This is valid where an image copy of the database is taken before the update job step.

Log initialization calculates the smallest value necessary for logical record length. If the JCL logical record length value is larger than the calculated value, the JCL value is used; otherwise, log initialization uses the calculated value for logical record length and adds 4 for the block size.

If multiple volumes are required for the system log, a volume count value should be specified in the VOL parameter of the DD statement.

If the IBM 3480 tape drive is used for the IMS log data set, IMS forces tape write mode (DCB=OPCD=W). The default on the 3480 is to serve as a buffer for the write so that IMS cannot detect when the write is performed. If a power failure occurs after a log record is written to the 3480, and the database is updated but the log record is not yet written to tape, database integrity is lost. Tape write mode is forced for the log in batch and for GSAM data sets.

Parameters

The following parameters are valid for the DLIBATCH procedure.

APARM=
BKO=
BUF=
CKPTID=
DBRC=
DBRCGRP=
DFSDF=
FMTO=
IMSID=
IMSPLEX=
OPB=
IRLM=
IRLMNM=
LOCKMAX=
LOGA=
LOGT=
MON=
NODE1=
NODE2=
PRLD=
PSB=
RGN=
RGSUF= (no default when specified in the batch procedure)
RRS=
SOUT=
SRCH=
SSM=
SWAP=
SYS2=

These parameters cannot be specified in the PARM1= and PARM2= parameters:

EXCPVR=
MBR=
RST=
SPIE=
TEST=

The IOB parameter is no longer used and is ignored if it is specified.

See [“Parameter descriptions for IMS procedures” on page 520](#) for descriptions.

DD statements

In addition to whichever of the following DD statements you use, your procedure must include DD statements for database data sets that will not be dynamically allocated.

The following DD statements are required for the DLIBATCH procedure.

DFSRESLB DD
DFSURWF1 DD is required when you run a DL/I batch processing program using a PROCOPT=L PCB. Otherwise, this DD statement is optional.
DFSVSAMP DD
IEFRDER DD
IMS DD, except when the IMS management of ACBs is enabled
IMSLOGR DD

IMSMON DD
 PROCLIB DD
 STEPLIB DD
 SYSABEND DD
 SYSUDUMP DD

The following DD statements are optional for the DLIBATCH procedure.

DFSHALDB DD
 DFSSTAT DD
 DFSURWF1 DD is optional, except when you run a DL/I batch processing program using a PROCOPT=L
 PCB, in which case it is required.
 IEFRDER2 DD
 SYSHALDB DD

See [“DD statement descriptions”](#) on page 583 for descriptions.

Procedure for an offline DL/I batch processing program using PSB and DBD libraries

```

//      PROC MBR=TEMPNAME,PSB=,BUF=7,
//      SPIE=0,TEST=0,EXCPVR=0,RST=0,PRLD=,
//      SRCH=0,CKPTID=,MON=N,LOGA=0,FMTO=T,
//      IMSID=,SWAP=,DBRC=,IRLM=,IRLMNM=,
//      BKO=N,IOB=,SSM=,APARM=,
//      RGN=4M,RGSUF=,PARM1=,PARM2=,
//      SOUT=A,LOGT=2400,SYS2=,
//      LOCKMAX=,GSGNAME=,TMINAME=,
//      RRS=N,IMSPLEX=,DFSDF=
//G      EXEC PGM=DFSRR00,REGION=&RGN,
//      PARM=(DLI,&MBR,&PSB,&BUF,
//      &SPIE&TEST&EXCPVR&RST,&PRLD,
//      &SRCH,&CKPTID,&MON,&LOGA,&FMTO,
//      &IMSID,&SWAP,&DBRC,&IRLM,&IRLMNM,
//      &BKO,&IOB,&SSM,'&APARM',
//      &LOCKMAX,&GSGNAME,&TMINAME,
//      &RRS,&IMSPLEX,&RGSUF,&DFSDF,
//      '&PARM1','&PARM2')
//STEPLIB DD DSN=IMS.&SYS2.SDFSRESL,DISP=SHR
//      DD DSN=IMS.&SYS2.PGMLIB,DISP=SHR
//DFSRESLB DD DSN=IMS.&SYS2.SDFSRESL,DISP=SHR
//IMS      DD DSN=IMS.&SYS2.PSBLIB,DISP=SHR
//      DD DSN=IMS.&SYS2.DBDLIB,DISP=SHR
//PROCLIB DD DSN=IMS.&SYS2.PROCLIB,DISP=SHR
//IEFRDER DD DSN=IMSLOG,DISP=(,KEEP),VOL=(,,99),
//      UNIT=(&LOGT,,DEFER),
//      DCB=(RECFM=VB,BLKSIZE=4096,
//      LRECL=4092,BUFNO=2)
//IEFRDER2 DD DSN=IMSLOG2,DISP=(,KEEP),VOL=(,,99),
//      UNIT=(&LOGT,,DEFER,SEP=IEFRDER),
//      DCB=(RECFM=VB,BLKSIZE=4096,
//      LRECL=4092,BUFNO=2)
//SYSUDUMP DD SYSOUT=&SOUT,
//      DCB=(RECFM=FBA,LRECL=121,BLKSIZE=605),
//      SPACE=(605,(500,500),RLSE,,ROUND)
//IMSMON  DD DUMMY
  
```

Related concepts

[“Specifying IMS execution parameters”](#) on page 177

You can specify control region execution parameters in the appropriate control region JCL, or in the IMS, DBC, and DCC members of the IMS PROCLIB data set. Parameters specified in these members override any system definition. The parameters are not positional.

Related reference

[“CATALOG and CATALOGxxxx sections of the DFSDFxxx member”](#) on page 756

The CATALOG and CATALOGxxxx sections contain options for an IMS catalog. The section headers must be specified as <SECTION=CATALOG> or <SECTION=CATALOGxxxx>. The CATALOG and CATALOGxxxx sections are valid in DB/DC, DBCTL, DCCTL and batch environments.

[IMS Catalog Definition exit routine \(DFS3CDX0\) \(Exit Routines\)](#)

DLISAS procedure

The DLISAS procedure initializes a DL/I separate address space (DLISAS).

If you specify LSO=S in the IMS procedure, automatically invoking the DLISAS procedure, the DD statements for the DL/I databases must be in the DLISAS procedure, not in the IMS procedure. Dynamic allocation members remain in the STEPLIB library.

For information about LSO=S, see [“Using a DL/I separate address space” on page 105](#).

The DLISAS procedure is shown in [“Sample procedure to initialize a DL/I separate address space” on page 632](#).

Usage

Other parameters in the IMS procedure that are applicable with the LSO=S option are DLINM, CSAPSB, and DLIPSB. DLINM specifies the partitioned data set (PDS) member name that IMS uses for the DLISAS procedure. The following list shows how the member name is assigned and how the name can be overridden.

1. DLISAS is the default name
2. The value specified on the DLINM= keyword in the IMSCTRL macro overrides the default name
3. The value specified on the DLINM= keyword in the DFSPBxxx member of the IMS PROCLIB data set overrides the value specified in the IMSCTRL macro
4. The value specified on the DLINM= keyword in JCL EXEC parameter overrides the value specified in the DFSPBxxx member of the IMS PROCLIB data set

The cataloged procedure (for the DLISAS) is stored in the IMS SDFSPROC data set during SMP/E processing. This member must be copied to SYS1.PROCLIB.

CSAPSB and DLIPSB specify the PSB pool sizes and override the values specified with the SASPSB parameter on the BUFPOOLS system definition macro.

Automatic initiation

An internally defined z/OS START command is issued for the DLINM value and is coded to override the PARM=(DLS,&IMSID) procedure statement. The override defines the IMSID of the subsystem issuing the START, allowing a generic procedure to be used by multiple IMS control regions.

IMS does not issue the IMS READY message until the DLISAS successfully initiates. If the started DLISAS procedure is in error, you should correct and restart it.

When the DL/I address space connects to the IMS control region, the DLISAS procedure name is compared with the DLINM value. If they differ, the DLISAS abends.

Manual initiation

You can supply a START command (in member=DLINM of a PDS defined in the control region JCL // PROCLIB) instead of using the internally defined z/OS START command. Columns 1-5 must be "START", or message DFS1930I is issued and the default process is performed.

You can specify two types of START commands:

- START IMSRDR, MBR=DLISAS: the specified PDS member is read in as a job (rather than as a started task) through the z/OS internal reader.
- START DLIAA, PARM=(DLS, IMSA): DL/I executes as a started task and DLIAA connects to IMSA.

Recommendation: Run your DL/I region as a started task, and specify the NODETAIL parameter in the SMFPRMxx member in SYS1.PARMLIB. Do not run your DL/I region as a job. While IMS supports running DL/I as a job, doing so can lead to storage shortages for long running DL/I regions that are managing a large number of databases. This is because z/OS SMF captures performance information in control blocks, which are kept in storage until the job terminates. These control blocks accumulate over time. A DL/I region that is active for a long period of time, and which is managing a large number of databases, can

eventually run out of storage due to the SMF measurement data that is collected. This storage buildup does not occur with started tasks when NODETAIL is specified in the SMFPRMxx member.

For active and inactive ACBLIBs, the data set names and their concatenation order must be identical (same DSN and VOLSER) in the DLISAS procedure and in the IMS procedure.

The IMS PROCLIB data set must be defined in the DLISAS procedure and in the IMS procedure. Sometimes the same DLINM member is read from the IMS PROCLIB data set by both the control region and DLISAS.

Important: If the resources (such as DL/I databases) are RACF-protected, the user ID associated with DLISAS procedure must be authorized to access them. For more information about how to authorize the user ID, see *IMS Version 15.4 System Administration*.

Parameters

The following parameters are valid for the DLISAS procedure.

DPRTY=
IMSID=
NODE1=
NODE2=
RGN=
SOUT=
SYS2=

See [“Parameter descriptions for IMS procedures”](#) on page 520 for descriptions.

DD statements

The following DD statements are valid for the DLISAS procedure.

In addition to these DD statements, DD statements for DL/I databases must be in the DLISAS procedure, not in the IMS procedure; add statements for data sets representing databases that are not to be dynamically allocated. DD statements for Fast Path databases remain in the IMS procedure.

IMSACBA DD
IMSACBB DD
IMSDALIB DD (optional)
PROCLIB DD
STEPLIB DD
SYSUDUMP DD

The IMSACBA and IMSACBB DD statements must be removed if you want to dynamically allocate the ACBLIB data sets through the DFSMDA member.

See [“DD statement descriptions”](#) on page 583 for descriptions.

Sample procedure to initialize a DL/I separate address space

```
//          PROC RGN=64M,DPTY='(14,15)',SOUT=A,  
//          IMSID=SYS3,SYS2=  
//IEFPROC EXEC PGM=DFSMVRC0,REGION=&RGN,  
//          DPRTY=&DPTY,PARM=(DLS,&IMSID)  
//*****  
//*  
//STEPLIB DD DSN=IMS.&SYS2.SDFSRESL,DISP=SHR  
//PROCLIB DD DSN=IMS.&SYS2.PROCLIB,DISP=SHR  
//***** ACBLIB *****  
//*  
//* THE SPECIFICATION OF THE ACBLIB DATASETS  
//* IN THE DLI/SAS REGION PROCEDURE MUST  
//* CORRESPOND EXACTLY WITH THE SPECIFICATION  
//* IN THE CONTROL REGION JCL. THE IMSACBA AND  
//* IMSACBB DD STATEMENTS MUST BE REMOVED IF YOU
```



```

//* WISH TO DYNAMICALLY ALLOCATE THE ACBLIB DATA
//* SETS THROUGH THE DFSMDA MEMBER.
//*
//IMSACBA DD DSN=IMS.&SYS2.ACBLIBA,DISP=SHR
//IMSACBB DD DSN=IMS.&SYS2.ACBLIBB,DISP=SHR
//SYSUDUMP DD SYSOUT=&SOUT
//SYSABEND DD SYSOUT=&SOUT
//***** DATA BASE DD CARDS *****
//*
//* USER MAY OPTIONALLY SUPPLY THE DD STATEMENTS
//* FOR THE ON-LINE DATA BASES TO BE
//* INSERTED HERE PRIOR TO ATTEMPTING
//* AN ON-LINE SYSTEM EXECUTION USING
//* THIS PROCEDURE.
//* IF NO DD STATEMENTS ARE SUPPLIED FOR
//* A DATA BASE, IMS ASSUMES THAT THIS
//* DATA BASE HAS BEEN DESCRIBED THROUGH
//* THE DFSMDA MACRO.

```

DXRJPROC procedure

The DXRJPROC procedure starts the internal resource lock manager (IRLM). This procedure is supplied on the IRLM distribution tape.

For information about obtaining the IRLM from the distribution tape and preparing it for use, see *IMS Version 15.4 Installation*.

The procedure shown in [“Sample procedure to start IRLM 2.2”](#) on page 634 executes IRLM 2.2.

Usage

When you install the IRLM, a unique copy of DXRJPROC should be created for each IRLM that might run concurrently. The procedure name and parameters should be changed, as required, for each IRLM. Because no default value is provided for the IRLMID parameter, the DXRJPROC procedure must at least be altered to assign a value for IRLMID.

In a configuration in which two systems are sharing data, the two IRLMs must execute concurrently. A typical way to define this configuration is:

- Procedure name IRLM1 with IRLMID=1
- Procedure name IRLM2 with IRLMID=2

For testing purposes, two IRLMs can communicate with one another by using the z/OS cross-system coupling facility while executing concurrently on a single system. A typical way to define this environment is:

- Procedure name JRLM1 with IRLMID=1 and IRLMNM=JRLM
- Procedure name KRLM8 with IRLMID=8 and IRLMNM=KRLM

IRLM has a global deadlock manager, which is designated as the IRLM with the lowest IRLMID. IRLMs in a Parallel Sysplex group dynamically readjust the global manager identity as members join and leave the group. If you are concerned about the placement of the global deadlock manager, you can put the lowest IRLMID on a specific processor.

Parameters

The following parameters are valid for the DXRJPROC procedure.

```

DEADLOK=
IRLMGRP=
IRLMID=
IRLMNM=
LOCKTAB=
LTE=
MAXCSA= (ignored by IRLM)

```

MAXUSRS=
PC= (IRLM sets PC=YES regardless of what is specified in the DXRJPROC procedure.)
PGPROT=
SCOPE=
TRACE=

See [“Parameter descriptions for IMS procedures”](#) on page 520 for descriptions.

DD statements

The following DD statements are valid for the DXRJPROC procedure:

STEPLIB DD
SYSABEND DD

See [“DD statement descriptions”](#) on page 583 for descriptions.

Sample procedure to start IRLM 2.2

```
//DXRJPROC PROC RGN=3072K,  
//          IRLNMN=IRLM,  
//          IRLMID=,  
//          SCOPE=LOCAL,  
//          DEADLOK='5,1',  
//          MAXCSA=8,  
//          PC=NO,  
//          MAXUSRS=,  
//          IRLMGRP=,  
//          LOCKTAB=IRLMT1,  
//          TRACE=YES,  
//          PGPROT=YES,  
//          LTE=  
//          EXEC PGM=DXRRLM00,DPRTY=(15,15),  
//          PARM=(&IRLMNM,&IRLMID,&SCOPE,&DEADLOK,&MAXCSA,  
//          &PC,&MAXUSRS,&IRLMGRP,&LOCKTAB,&TRACE,&PGPROT,&LTE),  
//          REGION=&RGN  
//STEPLIB DD DSN=SDXRLM21.SDXRRESL,DISP=SHR  
//*  
//* The following DUMP dd statement should not be specified unless  
//* you are having IRLM STARTUP problems and are not getting the  
//* dump needed to diagnosis the problem.  
//*  
//SYSABEND DD SYSOUT=A
```

FDR procedure

The FDR procedure executes a Fast Database Recovery (FDBR) address space.

Usage

For the FDR procedure, the sum of the values for the CSAPSB and DLIPSB defines the PSB pool size. If PSB is also specified, the larger value (PSB or the sum of CSAPSB and DLIPSB) is used.

If the Fast Path 64-bit buffer manager is being used, the DFSDF= parameter must be specified on the FDR procedure.

Parameters

The following parameters are valid for the FDR procedure.

ARMRST=
BSIZ=
CSAPSB=
CSLG=
DBBF=

DBRCGRP=
DBWP=
DESC=
DFSDF=
DLIPSB=
DMB=
DPRTY=
FMTO=
FP=
IMSID=
IMSPLEX=
IRLMNM=
LGNR=
MCS=
NODE1=
NODE2=
PSB=
PSBW=
RGN=
RGSUF=
SOUT=
SPM=
SUF=
SVC2=
SYS=
SYS2=
UHASH=
VSPEC=
WADS=
WKAP=

See [“Parameter descriptions for IMS procedures”](#) on page 520 for descriptions.

DD statements

The following DD statements are valid for the FDR procedure. In addition to the following DD statements, add statements for data sets that are not to be dynamically allocated.

DFSOLPn DD
DFSOLSn DD
DFSWADSn DD
IMSACBA DD
IMSACBB DD
IMSDALIB DD (optional)
IMSRDS DD
JCLOUT DD
JCLPDS DD
MODBLKSA DD (optional)
MODBLKSB DD (optional)
MODSTAT DD
PROCLIB DD
STEPLIB DD
SYSUDUMP DD

Note: The IMSACBA and IMSACBB DD statements must be removed if you want to dynamically allocate the ACBLIB data sets through the DFSMDA member. The PSBW space is used when OLR is in progress.

See “[DD statement descriptions](#)” on page 583 for descriptions.

JCL

The FDR procedure shown in the following example executes an FDBR address space:

```
//          PROC RGN=64M,SOUT=A,DPTY='(14,15)',
//          SYS=,SYS2=,
//          RGSUF=IMS, PARM1=, PARM2=
//IEFPROC EXEC PGM=DFSMVRC0,DPRTY=&DPTY,
//          REGION=&RGN,
//          PARM='FDR,&RGSUF,&PARM1,&PARM2'
//*
//*
//* THE MEANING AND MAXIMUM SIZE OF EACH PARAMETER
//* IS AS FOLLOWS:
//*
//***** CONTROL REGION SPECIFICATIONS *****
//*****
//* RGSUF XXX EXEC PARM DEFAULT BLOCK SUFFIX FOR
//* MEMBER DFSPBXXX.
//*****
//*
//* PARM1 , PARM2 PARAMETERS BOTH ARE USED TO SPECIFY
//* CHARACTER STRINGS THAT CONTAIN IMS KEYWORD
//* PARAMETERS. I.E. PARM1='AUTO=Y,PST=222,RES=Y'
//*
//* ALL OF THE VALID IMS KEYWORD PARAMETERS
//* ARE DESCRIBED BELOW
//*****
//* FMT0 T = ONLINE FORMATTED DUMP WITH
//* STORAGE IMAGE DELETIONS.
//* OFFLINE SDUMPS PERMITTED FOR
//* NON-IMS TERMINATING ERRORS.
//* P = FULL ONLINE FORMATTED DUMP.
//* OFFLINE SDUMPS PERMITTED FOR
//* NON-IMS TERMINATING ERRORS.
//* F = FULL ONLINE FORMATTED DUMP.
//* OFFLINE SDUMPS SUPPRESSED FOR
//* NON-IMS TERMINATING ERRORS.
//* N = NO FORMATTED DUMP, NO OFFLINE
//* DUMP. OFFLINE SDUMPS PERMITTED
//* FOR NON-IMS TERMINATING ERRORS
//* Z = NO FORMATTED DUMP, NO OFFLINE
//* DUMP. OFFLINE SDUMPS
//* SUPPRESSED FOR NON-IMS
//* TERMINATING ERRORS.
```

```
//* (DEFAULT) D = OFFLINE DUMP, OR ONLINE FORMAT-
//* TED DUMP WITH STORAGE IMAGE
//* DELETIONS IF OFFLINE DUMPING
//* FAILS. OFFLINE SDUMPS
//* PERMITTED FOR NON-IMS
//* TERMINATING ERRORS.
//* X = OFFLINE DUMP, OR ONLINE FORMAT-
//* TED DUMP WITH STORAGE IMAGE
//* DELETIONS IF OFFLINE DUMPING
//* FAILS. OFFLINE SDUMPS
//* SUPPRESSED FOR NON-IMS
//* TERMINATING ERRORS.
//* M = OFFLINE DUMP, ONLINE IMS DUMP
//* FORMATTING NOT PERMITTED.
//* OFFLINE SDUMPS PERMITTED FOR
//* NON-IMS TERMINATING ERRORS.
//* R = OFFLINE DUMP, ONLINE IMS DUMP
//* FORMATTING NOT PERMITTED.
//* OFFLINE SDUMPS SUPPRESSED FOR
//* NON-IMS TERMINATING ERRORS.
//* IMSID XXXX IMS SUBSYSTEM IDENTIFIER
//* ARMST X Y = ALLOW MVS ARM TO RESTART
//* N = ARM NOT RESTART IMS
//* IRLNM XXXX IRLM SUBSYSTEM NAME
//* WADS X SINGLE OR DUAL WADS,S=SINGLE,D=DUAL
//* UHASH XXXXXXXX USER HASH MODULE NAME
//* IMSPLEX XXXXX IMSPLEX NAME
```

```

//*  DESC  XX  MSG DESC CODE
//*  MCS   (XX,XX) MSG ROUTE CODES
//*  SVC2  XXX  TYPE 2 SVC NUMBER
//*  DBRCGRP XXX DBRC SHARING GROUP ID
//***** FAST PATH PARAMETERS *****/
//*
//*  BSIZ  XXXXX DATA BASE BUFFER SIZE
//*  DBBF  XXXXX NUMBER OF DATABASE BUFFERS
//*  LGNR  XX   NUMBER OF LOG ENTRIES IN DEDB BUFFERHEADER
//***** STORAGE POOL VALUES IN K, M OR G *****/
//*
//*  PSB   XXXXXX PSB POOL SIZE - NON DLISAS
//*  DMB   XXXXXX DMB POOL SIZE
//*  WKAP  XXXXXX WORKING STORAGE BUFFER POOL SIZE
//*  DBWP  XXXXXX DATABASE WORK POOL SIZE
//*  CSAPSB XXXXXX DLISAS: CSA PSB POOL SIZE
//*  DLIPSB XXXXXX DLISAS: DLI PSB POOL SIZE
//*
//***** MEMBER SUFFIXES *****/
//*
//*  SUF   X     LAST CHARACTER OF CTL PROGRAM LOAD
//*                MODULE MEMBER NAME
//*  VSPEC XX   2 CHARACTER BUFFER POOL SPEC MODULE SUFFIX
//*  SPM   XX   STG POOL MGR PROCLIB MEMBER SUFFIX
//*  CSLG  XXX  CSL GLOBAL MEMBER (DFSCGXXX)
//*
```

```

//*****
//*
//STEPLIB DD DSN=IMS.&SYS2.SDFSRESL,DISP=SHR
//PROCLIB DD DSN=IMS.&SYS2.PROCLIB,DISP=SHR
//JCLOUT DD SYSOUT=(A,INTRDR)
//JCLPDS DD DSN=IMS.&SYS2.PROCLIB,DISP=SHR
//*
//***** DASD LOGGING DD CARDS *****/
//* THE FOLLOWING DD CARDS DESCRIBE THE DASD LOGGING
//* OLDS AND WADS. THESE CARDS ARE FOR EXAMPLE ONLY.
//* ALL OLDS AND WADS DATA SETS MAY BE DYNAMICALLY
//* ALLOCATED. DD CARDS ARE NOT REQUIRED.
//* THE OLDS AND WADS TO BE USED DURING STARTUP MUST
//* BE SPECIFIED VIA OLDSDEF AND WADSDEF CONTROL
//* STATEMENTS IN THE DFSVSMXX MEMBER OF IMS PROCLIB.
//* THE ACTUAL SELECTION OF OLDS AND WADS MUST BE
//* TAILORED TO INSTALLATION REQUIREMENTS. THE OLDS
//* AND WADS MUST BE PREDEFINED BY A SET UP JOB.
//* THE BLOCK SIZE OF ALL OLDS MUST BE THE SAME.
//* THE BLOCK SIZE AND DEVICE TYPE OF ALL WADS MUST
//* BE THE SAME. AT LEAST 3 PRIMARY OLDS AND 1 WADS
//* MUST BE AVAILABLE FOR STARTUP. THE BLOCK SIZE
//* SHOULD NOT BE SPECIFIED IN THIS JCL. THE LOGGER
//* WILL GET THE BLOCK SIZE FROM THE VTOC.
//* THE IMSACBA AND IMSACBB DD STATEMENTS MUST BE
//* REMOVED IF YOU WISH TO DYNAMICALLY ALLOCATE THE
//* ACBLIB DATA SETS THROUGH THE DFSMDA MEMBER.
//*
//DFSOLP00 DD DSN=IMS.&SYS.OLP00,DISP=SHR
//DFSOLP01 DD DSN=IMS.&SYS.OLP01,DISP=SHR
//DFSOLP02 DD DSN=IMS.&SYS.OLP02,DISP=SHR
//DFSOLP03 DD DSN=IMS.&SYS.OLP03,DISP=SHR
//DFSOLP04 DD DSN=IMS.&SYS.OLP04,DISP=SHR
//DFSOLP05 DD DSN=IMS.&SYS.OLP05,DISP=SHR
//*
//DFSOLS00 DD DSN=IMS.&SYS.OLS00,DISP=SHR
//DFSOLS01 DD DSN=IMS.&SYS.OLS01,DISP=SHR
//DFSOLS02 DD DSN=IMS.&SYS.OLS02,DISP=SHR
//DFSOLS03 DD DSN=IMS.&SYS.OLS03,DISP=SHR
//DFSOLS04 DD DSN=IMS.&SYS.OLS04,DISP=SHR
//DFSOLS05 DD DSN=IMS.&SYS.OLS05,DISP=SHR
//*
//DFSWADS0 DD DSN=IMS.&SYS.WADS0,DISP=SHR
//DFSWADS1 DD DSN=IMS.&SYS.WADS1,DISP=SHR
//*
//IMSACBA DD DSN=IMS.&SYS2.ACBLIBA,DISP=SHR
//IMSACBB DD DSN=IMS.&SYS2.ACBLIBB,DISP=SHR
//MODBLKSA DD DSN=IMS.&SYS2.MODBLKSA,DISP=SHR
//MODBLKSB DD DSN=IMS.&SYS2.MODBLKSB,DISP=SHR
//MODSTAT DD DSN=IMS.&SYS.MODSTAT,DISP=SHR
```

```

//***** SYSTEM STATEMENTS *****/
//*
```

```

//SYSUDUMP DD SYSOUT=&SOUT,
//          DCB=(LRECL=125,RECFM=FBA,BLKSIZE=3129),
//          SPACE=(6050,300,,,ROUND)
//IMSRDS   DD DSN=IMS.&SYS.RDS,DISP=SHR
//*
//***** DATA BASE DD CARDS *****
//*
//* USER MAY OPTIONALLY SUPPLY THE DD STATEMENTS
//* FOR THE ON-LINE DATA BASES TO BE
//* INSERTED HERE PRIOR TO ATTEMPTING
//* AN ON-LINE SYSTEM EXECUTION USING
//* THIS PROCEDURE.
//* IF NO DD STATEMENTS ARE SUPPLIED FOR
//* A DATA BASE, IMS ASSUMES THAT THIS
//* DATA BASE HAS BEEN DESCRIBED THROUGH
//* THE DFSMDA MACRO.
//* IF THE USER WILL BE EXECUTING WITH THE DL/I
//* SAS OPTION, THESE DD STATEMENTS SHOULD BE ADDED
//* TO THE DLISAS PROCLIB MEMBER OR DESCRIBED
//* THROUGH THE DFSMDA MACRO.
//*
//***** DBRC RECON DD CARDS *****
//*
//* USER MAY OPTIONALLY SUPPLY THE DD CARDS
//* REQUIRED FOR THE DBRC RECON DATA SET.
//* IF NO DD STATEMENTS ARE SUPPLIED FOR RECON
//* DATASETS, IMS ASSUMES THAT THE DATASETS
//* HAVE BEEN DESCRIBED THROUGH THE DFSMDA MACRO.

```

FPUTIL procedure

The FPUTIL procedure executes the Fast Path utility programs with Data Entry Database (DEDB) online.

The JCL for the FPUTIL procedure is shown in [“Sample procedure to execute Fast Path utility programs”](#) on page 639. Parameters in parentheses are positional.

Parameters

The following parameters are valid for the FPUTIL procedure.

```

AGN=
ALTID=
DBD=
DIRCA=
IMSID=
NODE2=
PRLD=
REST=
RGN=
SOUT=
SSM=
SYS2=

```

See [“Parameter descriptions for IMS procedures”](#) on page 520 for descriptions.

DD statements

The following DD statements are valid for the FPUTIL procedure.

```

PROCLIB DD
STEPLIB DD
SYSPRINT DD
SYSUDUMP DD

```

See [“DD statement descriptions”](#) on page 583 for descriptions.

Restrictions

NBA= and OBA= are not valid parameters for this procedure. Instead, the default values NBA=7 and OBA=0 are used.

Sample procedure to execute Fast Path utility programs

```
//FPUTIL PROC SOUT=A,RGN=4M,SYS2=,  
//          DBD=,REST=00,DIRCA=002,  
//          PRLD=,IMSID=,AGN=,SSM=,ALTID=  
//FPU EXEC PGM=DFSRRC00,REGION=&RGN,  
//      PARM=(IFP,&DBD,DBF#FPU0,&REST,00,,1,  
//          &DIRCA,&PRLD,0,,, &IMSID,&AGN,&SSM,,  
//          &ALTID)  
//STEPLIB DD DSN=IMS.&SYS2.SDFSRESL,DISP=SHR  
//PROCLIB DD DSN=IMS.&SYS2.PROCLIB,DISP=SHR  
//SYSPRINT DD SYSOUT=&SOUT  
//SYSUDUMP DD SYSOUT=&SOUT,  
//          DCB=(LRECL=121,RECFM=VBA,BLKSIZE=3129),  
//          SPACE=(125,(2500,100),RLSE,,ROUND)
```

IMS procedure

The IMS procedure is an online execution procedure that initializes the IMS DB/DC environment.

Usage

In the sample shown in “JCL” on page 642:

- The PARM2 parameter is needed because z/OS:
 - Allows up to 100 characters in the EXEC parameter area
 - Does not allow symbolic parameters to be continued on next record
 - Does not allow more than 66 characters for each keyword option phrase on the **START** command
- On the Monitor statements, always specify the BLKSIZE and BUFNO parameters. For DASD use half-track blocking. This is BLKSIZE=27992 for 3990s. BUFNO=20 should be adequate for any system. For example, the following DD statement could be used to specify the BLKSIZE and BUFNO parameters:

```
//IMSMON DD DSN=IMS.IMSMON,DCB=(BLKSIZE=27992,BUFNO=20),DISP=SHR
```

- For the Fast Path statements, the DEDB areas must be allocated in the IMS control region address space, regardless of whether the DL/I SAS option is used. Allocation is attempted in the following order:
 - The DD statements are in the control region JCL
 - DEDB dynamic allocation from the RECON data set
 - Dynamic allocation members in the IMSDALIB concatenation or JOBLIB/STEPLIB concatenation

Recommendation: Register the databases with DBRC and do not use DFSMDA.

- The security parameters AGN=, AOI1=S, and ISIS=< 0 | 1 | 2 > continue to be accepted, but are ignored if specified. The security parameters RCF=, SGN=, and TRN= are no longer documented, but continue to perform the function that was provided in previous versions of IMS.

Dynamic resource definition

If you are defining your MODBLKS resources dynamically rather than using online change, the IMS procedure does not require the DD statements for the IMS.MODBLKS data sets, MODBLKSA and MODBLKSB. In addition, if the MODBLKSA and MODBLKSB DD statements are defined to an IMS system that was initially defined with dynamic resource definition and global online change enabled, they are ignored.

RACF and resource protection

If the resources (such as DL/I databases) are RACF protected, the user ID associated with the IMS procedure must be authorized to access them. For more information about how to authorize the user ID, see *IMS Version 15.4 System Administration*.

DLISAS procedure

If you specify LSO=S in the IMS procedure, automatically invoking the DLISAS procedure, the DD statements for the DL/I databases must be in the DLISAS procedure, not in the IMS procedure. Dynamic allocation members remain in the STEPLIB library.

Online change

IMSACB DD statements can optionally be added to the IMS procedure for the IMS staging ACBLIB that is used by ACBLIB member online change. If IMSACB DD statements are added, a dynamic allocation (DFSMDA) member for the IMS staging ACBLIB is not required.

Program Specification Block (PSB) pools

If you do not specify LSO=S in the IMS procedure, one PSB pool is created, as specified by the PSB parameter on the BUFPOOLS macro. If you specify LSO=S, two PSB pools are created and the PSB parameter is ignored. The pool sizes are specified with the SASPSB parameter on the BUFPOOLS system definition macro, and overridden with the CSAPSB and DLIPSB parameters on the IMS procedure. For an overview of information about the DL/I address space options, see *IMS Version 15.4 System Administration*.

Allocating terminal devices

If an online IMS system has been defined, carefully consider the terminal device allocation generated within the IMS procedure. A list of terminal addresses and logical and physical terminals is printed by stage 1 of IMS system definition. Examples of the procedure jobs in this information show the contents of the members as they are supplied. No card column image is intended. When coding your own procedures, follow JCL and assembler language coding practices.

Parameters

The following parameters are valid for the IMS procedure.

ALOT= to DPRTY=	DSCT= to LUMC=	LUMP= to QTU=	RCF= to YEAR4
ALOT=	DSCT=	LUMP=	RCF=
AOI1=	DYNP=	MAXPST=	RCFTCB=
AOIP=	EMHB=	MCS=	RCLASS=
AOIS=	EMHL=	MFSEXITF=	RDS=
APPC=	EPCB=	MFSEXITS=	RECA=
APPCSE=	ETO=	MNPS=	RECASZ=
APPLID1=	EXVR=	MNPSW=	RES=
APPLID2=	FBP=	MSC=	RGN=
APPLID3=	FDRMBR=	MSDB=	RGSUF=
ARMRST=	FESEXIT=	NHTS=	RRS=
ASOT=	FESTIM=	NLXB=	RVFY=
AUTO=	FIX=	NODE1=	SAV=
BSIZ=	FMTO=	NODE2=	SIMEXIT=
CCTCVCAN=	FP=	ODBASE=	SGN=
CIOP=	FPDSSIZE=	ORSMBR=	SHAREDQ=
CMDMCS=	FPOPN=	OTHR=	SHMSGSZ=
CPLOG=	FPRLM=	OTMA=	SOD=
CRC=	FPWP=	OTMAASY=	SOUT=
CSAPSB=	FRE=	OTMAMD=	SPM=
CSLG=	GRNAME=	OTMANM=	SRCH=
DBBF=	GRSNAME=	OTMASE=	SSM=
DBFP=	HIOP=	OTMASP=	SUF=
DBFX=	HSBID=	PASSWD1=	SVC2=
DBRCNM=	HSBMBR=	PIINCR=	SVSODR=
DBWP=	IMSGROUP=	PIMAX=	SYS1=
DC=	IMSID=	PRDR=	SYS=
DESC=	IOVFI=	PRLD=	TCORACF=
DFSDF=	IRLM=	PSB=	TRN=
DLIDSIZE=	IRLMNM=	PSBW=	TSR=
DLINM=	ISIS=	PST=	UHASH=
DLIPSB=	LGMSGSZ=	PSWDC=	UHTS=
DLQT=	LGNR=	QBUF=	USERMSGZ=
DMB=	LHTS=	QBUFHITH=	USERVAR=
DMHVF=	LSO=	QBUFLWTH=	VAUT=
DPRTY=	LTERM=	QBUFMAX=	VSPEC=
	LUMC=	QBUFSZ=	WKAP=
		QTL=	YEAR4=
		QTU=	

The following parameters are Fast Path parameters: BSIZ, DBBF, DBFP, DBFX, DMHVF, EPCB, FPOPN, FPRLM, IOVFI, LGNR, MSDB, OTHR, and UHASH.

See [“Parameter descriptions for IMS procedures” on page 520](#) for descriptions.

DD statements

The following parameters are valid for the IMS procedure.

In addition to the following DD statements, add statements for data sets representing IMS databases that are not to be dynamically allocated.

Sample procedures are generated during SMP/E processing in the IMS.SDFSPROC data set. The sample procedures contain DD statements for these device types: DISK, MSC channel-to-channel, PRINTER, PUNCH, READER, SPOOL, and TAPE. These DD statements corresponds to the LINEGRP definitions (or MSPLINK definition for MSC CTC) in the stage 1 definition. The new IMS procedure parts contain examples on how the DD statements should be coded based on the actual definitions defined by the installation. Modify the IMS procedure to specify the actual DD statements needed by the installation.

DFSDUPPM to IMSACBA	IMSACBB to MODBLKSB	MODSTAT to PROCLIB	QBLKS to SYSUDUMP
DFSDUPPM DD	IMSACBB DD (optional)	MODSTAT DD	QBLKS DD
DFSESL DD (optional)	IMSMON DD	MODSTAT2 DD	QBLKSL DD
DFSOLPnn DD	IMSRDS DD	MSDBCP1 DD	RECON1 DD (optional)
DFSOLSnn DD	IMSRDS2 DD	MSDBCP2 DD	RECON2 DD (optional)
DFSTCF DD (optional)	IMSTFMTA DD	MSDBCP3 DD	RECON3 DD (optional)
DFSWADSn DD	IMSTFMTB DD	MSDBCP4 DD	SHMSG DD
FORMATA DD	LGMSG DD	MSDBDUMP DD	SHMSGGL DD
FORMATB DD	LGMSGGL DD	MSDBINIT DD	STEPLIB DD
IMSACB DD	MODBLKSA	PRINTDD DD	SYSTPRT DD
IMSACBA DD (optional)	MODBLKSB	PROCLIB DD	SYSUDUMP DD
IMSDALIB DD(optional)			

See “DD statement descriptions” on page 583 for descriptions.

Notes:

- The IMSACBA and IMSACBB DD statements must be removed if you want to dynamically allocate the ACBLIB data sets through the DFSMDA member.
- If you are defining your MODBLKS resources dynamically, the DD statements for the MODBLKS data sets (MODBLKSA and MODBLKSB) are not required.
- In the sample IMS procedure that is built during SMP/E processing and placed in the ADFSPROC and SDFSPROC library data sets, the IMSMON DD statement is included as a comment. To use the IMSMON DD statement, remove the asterisks (*).

JCL

The following procedure executes an IMS DB/DC online control program.

```
//          PROC RGN=64M,SOUT=A,DPTY='(14,15)',
//          SYS=,SYS1=,SYS2=,
//          LOGT=2400,
//          RGSUF=IMS, PARM1=, PARM2=
//IEFPROC EXEC PGM=DFSMVRC0,DPRTY=&DPTY,
//          REGION=&RGN,
//          PARM='CTL,&RGSUF,&PARM1,&PARM2'
//*
//*
//* THE MEANING AND MAXIMUM SIZE OF EACH PARAMETER
//* IS AS FOLLOWS:
//*
//***** CONTROL REGION SPECIFICATIONS *****
//*****
//* RGSUF   XXX   EXEC PARM DEFAULT BLOCK SUFFIX FOR
//*          MEMBER DFSPBXXX.
//*****
//*
//* PARM1 , PARM2 PARAMETERS BOTH ARE USED TO SPECIFY
//* CHARACTER STRINGS THAT CONTAIN IMS KEYWORD
//* PARAMETERS. I.E. PARM1='AUTO=Y,PST=222,RES=Y'
```

```

//*
//* ALL OF THE VALID IMS KEYWORD PARAMETERS
//* ARE DESCRIBED BELOW
//*****
//* APPLID1 XXXXXXXX VTAM APPLID OF ACTIVE IMS SYSTEM
//* APPLID2 XXXXXXXX VTAM APPLID OF XRF ALTERNATE SYSTEM
//* APPLID3 XXXXXXXX VTAM APPLID OF RSR TRACKING SYSTEM

//* RES      X      BLOCK RESIDENT (N = NO, Y = YES)
//* FRE      XXXXX  NUMBER OF FETCH REQUEST ELEMENTS
//* PST      XXX    NUMBER OF PST'S PERMANENTLY ALLOC
//* MAXPST   XXX    MAXIMUM NUMBER OF PST'S
//* SAV      XXX    NUMBER OF DYNAMIC SAVE AREA SETS
//* SRCH     X      MODULE SEARCH INDICATOR FOR DIRECTED LOAD
//*          0 = STANDARD SEARCH
//*          1 = SEARCH JPA AND LPA BEFORE PDS
//* SOD      X      1 CHARACTER SYSOUT CLASS
//* VAUT     X      VTAM AUTH PATH OPTION (1=YES,0=NO)
//* FMTO     T      T = ONLINE FORMATTED DUMP WITH
//*                STORAGE IMAGE DELETIONS.
//*                OFFLINE SDUMPS PERMITTED FOR
//*                NON-IMS TERMINATING ERRORS.
//*                P = FULL ONLINE FORMATTED DUMP.
//*                OFFLINE SDUMPS PERMITTED FOR
//*                NON-IMS TERMINATING ERRORS.
//*                F = FULL ONLINE FORMATTED DUMP.
//*                OFFLINE SDUMPS SUPPRESSED FOR
//*                NON-IMS TERMINATING ERRORS.
//*                N = NO FORMATTED DUMP, NO OFFLINE
//*                DUMP. OFFLINE SDUMPS PERMITTED
//*                FOR NON-IMS TERMINATING ERRORS

```

```

//*          Z = NO FORMATTED DUMP, NO OFFLINE
//*          DUMP. OFFLINE SDUMPS
//*          SUPPRESSED FOR NON-IMS
//*          TERMINATING ERRORS.
//* (DEFAULT) D = OFFLINE DUMP, OR ONLINE FOR-
//*          MATTED DUMP WITH STORAGE IMAGE
//*          DELETIONS IF OFFLINE DUMPING
//*          FAILS. OFFLINE SDUMPS
//*          PERMITTED FOR NON-IMS
//*          TERMINATING ERRORS.
//*          X = OFFLINE DUMP, OR ONLINE FOR-
//*          MATTED DUMP WITH STORAGE IMAGE
//*          DELETIONS IF OFFLINE DUMPING
//*          FAILS. OFFLINE SDUMPS
//*          SUPPRESSED FOR NON-IMS
//*          TERMINATING ERRORS.
//*          M = OFFLINE DUMP, ONLINE IMS DUMP
//*          FORMATTING NOT PERMITTED.
//*          OFFLINE SDUMPS PERMITTED FOR
//*          NON-IMS TERMINATING ERRORS.
//*          R = OFFLINE DUMP, ONLINE IMS DUMP
//*          FORMATTING NOT PERMITTED.
//*          OFFLINE SDUMPS SUPPRESSED FOR
//*          NON-IMS TERMINATING ERRORS.
//* AUTO     X      Y = AUTOMATIC RESTART DESIRED
//*          N = NO AUTOMATIC RESTART
//* IMSID    XXXX  IMS SUBSYSTEM IDENTIFIER
//* NLXB     XXX   # ADD'L LXBS FOR MSC VTAM
//* LSO      X      Y = DL/I LOCAL STORAGE OPTION ON
//*          S = DLI/SAS OPTION
//*
//* APPC     X      Y = ACTIVATE APPC/IMS
//*          N = DO NOT ACTIVATE APPC/IMS
//* LTERM    X      Y = LTERM USED IN DFSAPPC PROCESS
//*          N = LTERM NOT USED IN DFSAPPC
//*          PROCESS
//* ARMST    X      Y = ALLOW MVS ARM TO RESTART
//*          N = ARM NOT RESTART IMS
//* RRS      X      Y = ENABLE PROT CONV SUPPORT
//*          N = DISABLE PROT CONV SUPPORT
//* IRLM     X      Y = YES, N = NO
//* IRLMNM   XXXX  IRLM SUBSYSTEM NAME
//* SSM      XXXX  EXT SUBSYSTEM PROCLIB MEMBER ID
//* UHASH    XXXXXXXX USER HASH MODULE NAME
//* DBRCNM   XXXXXXXX DBRC PROCLIB MEMBER NAME
//* DLINM    XXXXXXXX DL/I PROCLIB MEMBER NAME
//* PRDR     XXXXXXXX IMSRDR PROCLIB MEMBER NAME
//* FESTIM   XXXX  FRONTENDSWITCH TIMEOUT (SECONDS)

```

```

/** RECASZ XXXXX RECEIVE ANY BUFFER SIZE
/** PIMAX XXXXXX ENQ/DEQ POOL MAXIMUM BYTES
/** PIINCR XXXXXX ENQ/DEQ POOL INCREMENT
/** RECA XXX NUMBER OF RECEIVE ANY BUFFERS
/** CRC X COMMAND RECOGNITION CHARACTER

/** TSR X U = UTC TIME
/** L = LOCAL TIME (DEFAULT)
/** YEAR4 X N = 2-DIGIT DATE (DEFAULT)
/** Y = 4-DIGIT DATE
/** DC XXX DC PROC MEMBER SUFFIX IN
/** IMS.PROCLIB
/** DEFAULT VALUE IS 000
/** CPMLOG XXXXXX CHECKPOINT LOG INTERVAL
/** OR
/** CPMLOG XXM CHECKPOINT LOG INTERVAL
/** PASSWD1 XXXXXXXX VTAM ACB PASSWORD
/** ORSMBR XX SUFFIX FOR ORS MEMBER
/** MSGROUP XXXX 4 CHAR USER SPEC NAME
/** DESC XX MSG DESC CODE
/** MCS (XX,XX) MSG ROUTE CODES
/** SVC2 XXX TYPE 2 SVC NUMBER
/** CCTVCAN X Y = CCTL CANCEL WILL BE CONVERTED
/** TO ABEND SYSTEM 08E
/** N = CCTL CANCEL IS NOT CONVERTED
/**
/** ***** OTMA PARAMETERS *****
/**
/** OTMA X Y = OTMA ENABLED
/** N = OTMA NOT ENABLED
/** DEFAULT VALUE IS N
/** OTMANM XXXXXXXX IMS OTMA XCF MEMBER NAME
/** GRNAME XXXXXXXX OTMA XCF GROUP NAME
/** NO DEFAULT VALUE
/** GRSNAME XXXXXXXX GENERIC RESOURCE GROUP
/** NAME
/** NO DEFAULT VALUE
/**
/** ***** SECURITY PARAMETERS *****
/**
/** AOIS X ICMD SECURITY OPTION
/** AOI1 X CMD SECURITY OPTION
/** A = ALL
/** N = NONE
/** C = DFSCCMD0 EXIT
/** R = RACF
/** TCORACF X TCO RACF SECURITY OPTION
/** Y = YES
/** N = NO
/** APPCSE X C = APPC RACF SECURITY IS CHECK
/** F = APPC RACF SECURITY IS FULL
/** N = APPC RACF SECURITY IS NONE
/** P = APPC RACF SECURITY IS PROFILE
/** CMDMCS X MCS/EMCS COMMAND OPTION
/** N=COMMANDS NOT ALLOWED WITH CRC
/** Y=ALL COMMANDS ALLOWED WITH CRC
/** R=RACF COMMAND SECURITY
/** C=DFSCCMD0 COMMAND SECURITY
/** B=RACF AND DFSCCMD0 CMD SEC
/** ISIS X N = NO RESOURCE ACCESS SECURITY
/** R = RACF RESOURCE ACCESS SECURITY
/** C = RACF RESOURCE ACCESS SECURITY
/** A = RACF RESOURCE ACCESS SECURITY

/** RCF X RACF USED FOR TRANS. AND SIGNON
/** A = Y + S, Y = T + C, S = S + C.
/** RVFY X RACF REVERIFY OPTION
/** Y = YES, N = NO
/** SGN X SIGNON AUTHORIZATION CHECKING
/** F = MTO CANNOT NEGATE ACTIVATION
/** OF SIGNON VERIFICATION
/** SECURITY
/** Y = SIGNON VERIFICATION SECURITY
/** WILL BE ACTIVATED
/** N = SIGNON VERIFICATION SECURITY
/** WILL NOT BE ACTIVATED
/** M = SINGLE USERID CAN SIGNON
/** TO MULTIPLE STATIC TERMINALS
/** G = 'F' + 'M'
/** Z = 'Y' + 'M'

```

```

//* TRN      X      TRANSACTION AUTHORIZATION CHECKING
//*          F = FORCED, Y = YES, N = NO
//* RCFTCB  XX      NUMBER OF RCF TCB'S
//* PSWDC   X      PASSWORD CASE
//*          U=UPPER CASE
//*          M=MIXED CASE
//*          R=USES RACF SETTING (DEFAULT)
//*
//***** MESSAGE QUEUE PARAMETERS *****
//*
//* EXVR     X      PAGEFIX QMGR BUFFER POOLS
//*          (1=YES, 0=NO)
//* QBUF     XXXX   NUMBER OF MESSAGE QUEUE BUFFERS
//* QTL      XXX    QUEUE LOWER THRESHOLD (%)
//* QTU      XXX    QUEUE UPPER THRESHOLD (%)
//*
//***** SHARED QUEUES PARAMETERS *****
//*
//* LGMSGSZ XXXXX  LONG MESSAGE SIZE
//* QBUFHITH XXX   MSG QBUF HIGH THESHOLD %
//* QBUFLWTH XXX   MSG QBUF LOW THESHOLD %
//* QBUFMAX  XXXX  MAX NUMBER OF MSG QUEUE BUFFERS
//* QBUFPCTX XXX   % MSG QBUF DYNAMIC EXPAND
//*          WHEN QBUFHITH EXCEEDED
//*          DEFAULT IS 20%
//* QBUFSZ   XXXXX SIZE OF MESSAGE QUEUE BUFFERS
//* SHMSGSZ  XXXXX SHORT MESSAGE SIZE
//* SHAREDQ  XXX   SQ PROC MEMBER SUFFIX IN
//*          IMS.PROCLIB
//*          NO DEFAULT VALUE
//*
//***** XRF PARAMETERS *****
//*
//* HSBID    X      XRF SYSTEM ID
//*          1 FOR FIRST SYSTEM
//*          2 FOR SECOND SYSTEM
//*
//* HSBMBR   XX     SUFFIX FOR XRF MEMBER IN
//*          IMS.PROCLIB
//*          00 IS DEFAULT
//*
//***** MNPS *****
//* MNPS     XXXXXXXX NAME OF MNPS ACB
//*          USERVAR WILL BE IGNORED
//* MNPSPW   XXXXXXXX MNPS ACB PASSWORD
//*
//***** FDR PARAMETER *****
//*
//* FDRMBR   XX     SUFFIX FOR FDR MEMBER IN
//*          IMS.PROCLIB
//*
//***** FAST PATH PARAMETERS *****
//*
//* BSIZ     XXXXX  DATA BASE BUFFER SIZE
//* OTHR     XXX    NUMBER OF OUTPUT THREADS
//* DBFX     XXXXX  SYSTEM ALLOCATION OF DATA BASE BUFFERS TO BE
//*          FIXED AT START OF 1ST FAST PATH DEP REGION
//* DBBF     XXXXX  NUMBER OF DATABASE BUFFERS
//* DBFP     XXXX   PAGE FIX/FREE ADJUST TIMER
//*          0: FIX/FREE AT SCHED/TERM
//*          1: ALLOW PAGEFIX ONLY
//*          2-3600: SEC PAGEFREE FREQ
//* MSDB     X      SUFFIX FOR MSDB MEMBER ON
//*          IMS.PROCLIB
//* LGNR     XX     NUMBER OF LOG ENTRIES IN DEDB BUFFERHEADER
//* EPCB     XXXX   EPCB POOL SIZE (1K BLOCKS)
//* EMHL     XXXXX  SIZE OF EMH BUFFER IN BYTES
//* SVSODR   XXXX   SVSO DISASTER RECOVERY OPTIONS
//*          NONE: DEFAULT. NO CHANGE TO ERE.
//*          AUTO: AREA MARKED RECOV NEEDED IF
//*          DRRS: AREA MARKED RECOV NEEDED AT
//*          WTOR: USER OPTION TO MARK AREAS
//*
//* DMHVF   XX     MEGS TO FIX PAGEFIX FOR VSO ERE DATASPACE
//* FPOPN    X      PREOPEN/REOPEN OPTIONS FOR DEDBS
//*          N: DEFAULT. PREOPEN OF DEDB AREAS
//*          DONE BEFORE IMS RESTART
//*          COMPLETES

```

```

//*      D: DEDB PREOPEN/PRELOAD IS DIS-
//*      ABLED AT CTL REGION INIT
//*      R: REOPEN AREAS OPENED WHEN IMS
//*      ABNORMALLY TERMINATED. BEHAVE
//*      LIKE OPTION P FOR NON /ERE
//*      P: PREOPEN OF DEDB AREA
//*      INITIATED AT THE END OF
//*      RESTART
//*      A: OPTION R AND P COMBINED
//*      FPRLM  X  DEDB OPTIONS FOR IRLM RECONNECT
//*      N: DEFAULT. NO ACTION TAKEN
//*      S: RESTART ALL DEDB AREAS WHICH
//*      WERE STARTED WHEN IRLM
//*      DISCONNECTED
//*      R: RESTART AND REOPEN ALL DEDB
//*      AREAS WHICH WERE STARTED WHEN
//*      IRLM DISCONNECTED
//*      P: PREOPEN OF DEDB AREA
//*      INITIATED AT THE END OF
//*      IRLM RECONNECT
//*      A: COMBINE OPTIONS R AND P
//*      FP      X  INCLUDE FASTPATH IN THIS IMS
//*      N: THE DEFAULT. THIS IMS DOES
//*      NOT INCLUDE FASTPATH
//*      Y: THIS IMS INCLUDES FASTPATH
//*
//***** MSC PARAMETER *****
//*      MSC      X  ENABLE OR DISABLE MSC IN THIS IMS
//*      N: DO NOT INCLUDE MSC.
//*      UNLESS MSC RESOURCES ARE DEFINED
//*      DURING SYSTEM DEFINITION, MSC=N
//*      IS THE DEFAULT.
//*      Y: INCLUDE MSC IN THIS IMS.
//*
//***** ETO PARAMETERS *****
//*
//*      ETO      X      Y = EXTENDED TERMINAL OPTION
//*      N = NO EXTENDED TERMINAL OPTION
//*      M = NO EXTENDED TERMINAL OPTION
//*      BUT LOGON USERDATA SUPPORTED
//*      FOR STATIC TERMINALS
//*      ASOT     XXXX  ETO AUTO SIGNOFF TIME
//*      ALOT     XXXX  ETO AUTO LOGNOFF TIME
//*      DLQT     XXX   ETO DEAD LETTER QUEUE SIZE
//*

```

```

//***** HASH TABLE PARAMETERS *****
//*
//*      LHTS     XXXXX # OF CNT HASH TABLE SLOTS
//*      NHTS     XXXXX # OF VTCB HASH TABLE SLOTS
//*      UHTS     XXXXX # OF SPQB HASH TABLE SLOTS
//*
//***** STORAGE POOL VALUES IN K, M OR G *****
//*
//*      FBP      XXXXXX MESSAGE BUFFER POOL SIZE
//*      PSB      XXXXXX PSB POOL SIZE - NON DLISAS
//*      DMB      XXXXXX DMB POOL SIZE
//*      CIOP     XXXXXX CIOP POOL UPPER LIMIT
//*      WKAP     XXXXXX WORKING STORAGE BUFFER POOL SIZE
//*      PSBW     XXXXXX PSB WORK POOL SIZE
//*      DBWP     XXXXXX DATABASE WORK POOL SIZE
//*      CSAPSB   XXXXXX DLISAS: CSA PSB POOL SIZE
//*      DLIPSB   XXXXXX DLISAS: DLI PSB POOL SIZE
//*      EPCB     XXXXXX EPCB POOL SIZE
//*      HIOP     XXXXXX HIOP POOL UPPER LIMIT
//*      FPWP     XXXXXX FPWP POOL UPPER LIMIT
//*      EMHB     XXXXXX EMHB POOL UPPER LIMIT
//*      LUMP     XXXXXX LUMP POOL UPPER LIMIT
//*      LUMC     XXXXXX LUMC POOL UPPER LIMIT
//*      DYNP     XXXXXX DYNP POOL UPPER LIMIT
//*      AOIP     XXXXXX AOI POOL UPPER LIMIT
//*      CMDP     XXXXXX CMDP POOL UPPER LIMIT
//*
//***** MEMBER SUFFIXES *****
//*
//*      SUF      X      LAST CHARACTER OF CTL PROGRAM LOAD
//*      MODULE MEMBER NAME
//*      FIX      XX     2 CHARACTER FIX PROCEDURE MODULE SUFFIX
//*      PRLD     XX     2 CHARACTER PROCLIB MEMBER SUFFIX FOR PRELOAD
//*      VSPEC    XX     2 CHARACTER BUFFER POOL SPEC MODULE SUFFIX
//*      SPM      XX     STG POOL MGR PROCLIB MEMBER SUFFIX

```

```

//*   CSLG   XXX   CSL GLOBAL MEMBER (DFSCGXXX)
//*   DSCT   X    ETO USER DESCRIPTOR TABLE(DFSDSCTX)
//*   DFSDF  XXX   DRD, CSL, AND SQ MEMBER (DFSDFXXX)
//*
//*****
//*
//*   DATA DEFINITION STATEMENTS FOLLOW           *
//*                                               *
//*****
//*
//***** LIBRARY STATEMENTS *****
//*
//STEPLIB DD DSN=IMS.&SYS2.SDFSRESL,DISP=SHR
//PROCLIB DD DSN=IMS.&SYS2.PROCLIB,DISP=SHR
//*
//***** GENERIC START DEPENDANT REGION *****
//*
//* IN ORDER TO START A DEPENDENT REGION, MODIFIED
//* START-UP JCL IS WRITTEN FROM INTERNAL STORAGE TO
//* THE INTERNAL READER.
//*
//IMSIRD  DD SYSOUT=(A,INTRDR)
//*

```

```

//***** MONITOR STATEMENTS *****
//*
//* THE IMSMON DD STATEMENT MUST BE REMOVED IF
//* THIS DATA SET IS TO BE DYNAMICALLY ALLOCATED.
//*
//IMSMON  DD DSN=IMS.&SYS1.IMSMON,DISP=(,KEEP),
//        VOL=(,99),UNIT=(&LOGT,,DEFER)
//*
//***** MESSAGE QUEUE STATEMENTS *****
//*
//QBLKS   DD DSN=IMS.&SYS1.QBLKS,DISP=OLD
//SHMSG   DD DSN=IMS.&SYS1.SHMSG,DISP=OLD
//LGMSG   DD DSN=IMS.&SYS1.LGMSG,DISP=OLD
//QBLKSL  DD DSN=IMS.&SYS1.QBLKSL,DISP=OLD
//SHMSGSL DD DSN=IMS.&SYS1.SHMSGSL,DISP=OLD
//LGMSGSL DD DSN=IMS.&SYS1.LGMSGSL,DISP=OLD
//*
//***** ONLINE CHANGE STATEMENTS *****
//*
//* THE IMSACBA AND IMSACBB DD STATEMENTS MUST BE
//* REMOVED IF YOU WISH TO DYNAMICALLY ALLOCATE THE
//* ACBLIB DATA SETS THROUGH THE DFSMDA MEMBER.
//*
//IMSACBA DD DSN=IMS.&SYS2.ACBLIBA,DISP=SHR
//IMSACBB DD DSN=IMS.&SYS2.ACBLIBB,DISP=SHR
//MODBLKSA DD DSN=IMS.&SYS2.MODBLKSA,DISP=SHR
//MODBLKSB DD DSN=IMS.&SYS2.MODBLKSB,DISP=SHR
//MODSTAT  DD DSN=IMS.&SYS2.MODSTAT,DISP=SHR
//MODSTAT2 DD DSN=IMS.&SYS2.MODSTAT2,DISP=SHR

```

```

//***** FAST PATH STATEMENTS *****
//*
//* THE MSDB DD STATEMENTS ARE BEING CREATED AS
//* COMMENTS. THE ASTERISK IN IN COLUMN THREE NEEDS
//* TO BE DELETED TO HAVE THE DD STATEMENT ACTIVATED
//*
//*MSDBCP1 DD DSN=IMS.&SYS2.MSDBCP1,DISP=SHR
//*MSDBCP2 DD DSN=IMS.&SYS2.MSDBCP2,DISP=SHR
//*MSDBCP3 DD DSN=IMS.&SYS2.MSDBCP3,DISP=SHR
//*MSDBCP4 DD DSN=IMS.&SYS2.MSDBCP4,DISP=SHR
//*MSDBDUMP DD DSN=IMS.&SYS1.MSDBDUMP,DISP=SHR
//*MSDBINIT DD DSN=IMS.&SYS2.MSDBINIT,DISP=SHR
//*
//***** MFS STATEMENTS *****
//*
//FORMATA DD DSN=IMS.&SYS2.FORMAT,DISP=SHR
//FORMATB DD DSN=IMS.&SYS2.FORMATB,DISP=SHR
//IMSTFMTA DD DSN=IMS.&SYS2.TFORMAT,DISP=SHR
//        DD DSN=IMS.&SYS2.FORMAT,DISP=SHR
//IMSTFMTB DD DSN=IMS.&SYS2.TFORMAT,DISP=SHR
//        DD DSN=IMS.&SYS2.FORMATB,DISP=SHR
//*
//***** SYSTEM STATEMENTS *****
//*
//SYSUDUMP DD SYSOUT=&SOUT,

```

```

//          DCB=(LRECL=125,RECFM=FBA,BLKSIZE=3129),
//          SPACE=(6050,300,,,ROUND)
//IMSRDS   DD DSN=IMS.&SYS.RDS,DISP=SHR
//IMSRDS2  DD DSN=IMS.&SYS.RDS2,DISP=SHR
//*DFSTCF  DD DSN=IMS.TCFSLIB,DISP=SHR
//PRINTDD  DD SYSOUT=&SOUT
//*
//***** TELEPROCESSING LINE STATEMENTS *****
//***** GENERATED FROM THE DB/DC DEFINITION *****
//*
//* *** THE GENERATED TELEPROCESSING LINE STATEMENTS WOULD BE HERE ***
//*
//***** EXTERNAL SUBSYSTEM STATEMENTS *****
//*
//* USER MAY OPTIONALLY ADD THE DFSESL DD CARD
//* FOR EXTERNAL SUBSYSTEM CONNECTION.
//*
//***** DATA BASE STATEMENTS *****
//*
//* USER MAY OPTIONALLY SUPPLY THE DD STATEMENTS
//* FOR THE ON-LINE DATA BASES TO BE
//* INSERTED HERE PRIOR TO ATTEMPTING
//* AN ON-LINE SYSTEM EXECUTION USING
//* THIS PROCEDURE.
//* IF NO DD STATEMENTS ARE SUPPLIED FOR
//* A DATA BASE, IMS ASSUMES THAT THIS
//* DATA BASE HAS BEEN DESCRIBED THROUGH
//* THE DFSMDA MACRO.
//* IF THE USER WILL BE EXECUTING WITH THE DL/I
//* SAS OPTION, THESE DD STATEMENTS SHOULD BE ADDED
//* TO THE DLISAS PROCLIB MEMBER OR DESCRIBED
//* THROUGH THE DFSMDA MACRO.

```

IMSBATCH procedure

The IMSBATCH procedure executes an IMS online batch message processing address space.

The procedure shown in [“Sample procedure to execute DB/DC or DBCTL online batch message processing region”](#) on page 649 executes an IMS DB/DC or IMS DBCTL online batch message processing region. Parameters in parentheses are positional.

Parameters

The following parameters are valid for the IMSBATCH procedure.

```

AGN=
ALTID=
APARM=
CKPTID=
CPUTIME=
DIRCA=
ENVIRON=
IMSID=
IN=
JVM=
JVMOPMAS=
LOCKMAX=
MBR=
NODE1=
NODE2=
OBA=
OPT=
OUT=
PARDLI=
PREINIT=

```

PRLD=
 PSB=
 RGN=
 SOUT=
 SPIE=
 SSM=
 STIMER=
 SYS2=
 TEST=

See [“Parameter descriptions for IMS procedures”](#) on page 520 for descriptions.

DD statements

The following DD statements are valid for the IMSBATCH procedure.

DFSCCTL DD (optional)
 DFSESL DD (optional)
 DFSHALDB DD (optional)
 DFSSTAT DD (optional)
 FPTRACE DD (optional)
 IMS DD (optional)
 IMSLOGR DD
 PROCLIB DD
 STDENV DD
 STEPLIB DD
 SYSHALDB DD (optional)
 SYSUDUMP DD

Note: If the checkpoint records that are required to restart the BMP do not exist in the online log data sets (OLDSn), an //IMSLOGR DD statement specifying a data set containing the checkpoint log records must be added to the BMP job's JCL.

See [“DD statement descriptions”](#) on page 583 for descriptions.

Sample procedure to execute DB/DC or DBCTL online batch message processing region

```

//      PROC  MBR=TEMPNAME,PSB=,IN=,OUT=,
//          OPT=N,SPIE=0,TEST=0,DIRCA=000,
//          PRLD=,STIMER=,CKPTID=,PARDLI=,
//          CPUTIME=,NBA=,OBA=,IMSID=,AGN=,
//          SSM=,PREINIT=,RGN=56K,SOUT=A,
//          SYS2=,ALTID=,APARM=,LOCKMAX=,
//          ENVIRON=,JVMOPMAS=
// *
//G      EXEC  PGM=DFSRR00,REGION=&RGN,
//          PARM=(BMP,&MBR,&PSB,&IN,&OUT,
//          &OPT&SPIE&TEST&DIRCA,&PRLD,
//          &STIMER,&CKPTID,&PARDLI,&CPUTIME,
//          &NBA,&OBA,&IMSID,&AGN,&SSM,
//          &PREINIT,&ALTID,
//          '&APARM',&LOCKMAX,&ENVIRON,&JVMOPMAS)
//STEPLIB DD DSN=IMS.&SYS2.SDFSRESL,DISP=SHR
//          DD DSN=IMS.&SYS2.PGMLIB,DISP=SHR
//PROCLIB DD DSN=IMS.&SYS2.PROCLIB,DISP=SHR
//SYSUDUMP DD SYSOUT=&SOUT,
//          DCB=(LRECL=121,RECFM=VBA,BLKSIZE=3129),
//          SPACE=(125,(2500,100),RLSE,,ROUND)
  
```

Sample procedure to execute DB/DC or DBCTL online batch message processing region with JVM=3164

```
//      PROC MBR=TEMPNAME,PSB=,IN=,OUT=,
//      OPT=N,SPIE=0,TEST=0,DIRCA=000,
//      PRLD=,STIMER=,CKPTID=,PARDLI=,
//      CPUTIME=,NBA=,OBA=,IMSID=,AGN=,
//      SSM=,PREINIT=,RGN=56K,SOUT=A,
//      SYS2=,ALTID=,APARM=,LOCKMAX=,
//      ENVIRON=,JVMOPMAS=,JVM=3164
// *
//G      EXEC PGM=DFSRRC00,REGION=&RGN,
//      PARM=(BMP,&MBR,&PSB,&IN,&OUT,
//      &OPT&SPIE&TEST&DIRCA,&PRLD,
//      &STIMER,&CKPTID,&PARDLI,&CPUTIME,
//      &NBA,&OBA,&IMSID,&AGN,&SSM,
//      &PREINIT,&ALTID,
//      '&APARM',&LOCKMAX,&ENVIRON,&JVMOPMAS,&JVM)
//STEPLIB DD DSN=IMS.&SYS2.SDFSRESL,DISP=SHR
//      DD DSN=IMS.&SYS2.SDFSJLIB,DISP=SHR
//      DD DSN=IMS.&SYS2.PGMLIB,DISP=SHR
//PROCLIB DD DSN=IMS.&SYS2.PROCLIB,DISP=SHR
//SYSUDUMP DD SYSOUT=&SOUT,
//      DCB=(LRECL=121,RECFM=VBA,BLKSIZE=3129),
//      SPACE=(125,(2500,100),RLSE,,ROUND)
```

IMSCOBGO procedure

The IMSCOBGO procedure is a three-step compile, bind, and go procedure combining the IMSCOBOL procedure with an execution step for a stand-alone DL/I batch address space.

JCL

In the sample IMSCOBGO procedure JCL:

- Parameters in parentheses are positional.
- The IMS PROCLIB data set should have the same block size as SYS1.PROCLIB, which should be 80, 400, or 3200.
- The IEFRRD and IEFRRD2 statements are not required in DB/DC or DBCTL environments if the job does not declare database update intent.
- Assumptions:
 - You supply source data from SYSIN.
 - Output class is A.
 - MBR=NAME, where NAME is the load module name for the program.
 - SYSDA is a generic device name.

If VSAM databases are used, see [“IMS buffer pools”](#) on page 206.

```
//      PROC MBR=TEMPNAME,PAGES=60,SYS2=,
//      LNGPRFX=IGY,
//      LIBPRFX=CEE,
//      SOUT=A,RGN=4M,LOGT=2400,
//      PSB=,BUF=7,SPIE=0,TEST=0,EXCPVR=0,
//      RST=0,PRLD=,SRCH=0,CKPTID=,MON=N,
//      LOGA=0,FMT0=T,IMSID=,SWAP=,DBRC=,IRLM=,
//      IRLMM=,BKO=N,IOB=,SSM=,APARM=,
//      LOCKMAX=,IMSPLEX=
//C      EXEC PGM=IGYCRCTL,REGION=4M,
//      PARM='SIZE(832K),BUF(10K),LINECOUNT(50)'
//STEPLIB DD DSN=&LNGPRFX..SIGYCOMP,
//      DISP=SHR
//SYSLIN DD DSN=&&LIN,DISP=(MOD,PASS),UNIT=SYSDA,
//      DCB=(IMS.&SYS2.PROCLIB),
//      SPACE=(3520,(40,10),RLSE,,ROUND)
//SYSPRINT DD SYSOUT=&SOUT,
//      DCB=(LRECL=121,BLKSIZE=605,RECFM=FBA),
//      SPACE=(605,(&PAGES.0,&PAGES),RLSE,,ROUND)
//SYSUT1 DD UNIT=SYSDA,SPACE=(CYL,(1,1))
```

```

//SYSUT2 DD UNIT=SYSDA,SPACE=(CYL,(1,1))
//SYSUT3 DD UNIT=SYSDA,SPACE=(CYL,(1,1))
//SYSUT4 DD UNIT=SYSDA,SPACE=(CYL,(1,1))
//SYSUT5 DD UNIT=SYSDA,SPACE=(CYL,(1,1))
//SYSUT6 DD UNIT=SYSDA,SPACE=(CYL,(1,1))
//SYSUT7 DD UNIT=SYSDA,SPACE=(CYL,(1,1))
//L EXEC PGM=IEWL,REGION=4M,
// PARM='XREF,LET,LIST',
// COND=(8,LT,C)
//SYSLIB DD DSN=&LIBPRFX..SCEELKED,
// DISP=SHR
//DFSRESLB DD DSN=IMS.&SYS2.SDFSRESL,DISP=SHR
//SYSLIN DD DSN=&&LIN,DISP=(OLD,DELETE),
// VOL=REF=*..C.SYSLIN
// DD DISP=SHR,
// DSN=IMS.&SYS2.PROCLIB(CBLTDLI)
// DD DDNAME=SYSIN
//SYSLMOD DD DISP=SHR,
// DSN=IMS.&SYS2.PGMLIB(&MBR)
//SYSRINT DD SYSOUT=&SOUT,
// DCB=(RECFM=FBA,LRECL=121,BLKSIZE=605),
// SPACE=(605,(&PAGES.0,&PAGES),RLSE,,ROUND)
//SYSUT1 DD UNIT=(SYSDA,SEP=(SYSLMOD,SYSLIN)),
// DISP=(,DELETE),
// SPACE=(3520,(100,10),RLSE,,ROUND)
//G EXEC PGM=DFSRR00,REGION=&RGN,TIME=2,
// COND=((8,LT,C),(4,LT,L)),
// PARM=(DLI,&MBR,&PSB,&BUF,
// &SPIE&TEST&EXCPVR&RST,
// &PRLD,&SRCH,&CKPTID,&MON,&LOGA,
// &FMTO,&IMSID,&SWAP,
// &DBRC,&IRLM,&IRLMNM,&BKO,&IOB,
// &SSM,'&APARM',&LOCKMAX,,&IMSPLEX)
//STEPLIB DD DSN=IMS.&SYS2.SDFSRESL,DISP=SHR
// DD DSN=IMS.&SYS2.PGMLIB,DISP=SHR
// DD DSN=&LIBPRFX..SCEERUN,DISP=SHR
//DFSRESLB DD DSN=IMS.&SYS2.SDFSRESL,DISP=SHR
//IMS DD DSN=IMS.&SYS2.PSBLIB,DISP=SHR
// DD DSN=IMS.&SYS2.DBDLIB,DISP=SHR
//PROCLIB DD DSN=IMS.&SYS2.PROCLIB,DISP=SHR
//IEFRDRE DD DSN=IMSLOG,DISP=(,KEEP),VOL=(,,99),
// UNIT=(&LOGT,,DEFER),
// DCB=(RECFM=VB,BLKSIZE=4096,
// LRECL=4092,BUFNO=2)
//IEFRDRE2 DD DSN=IMSLOG2,DISP=(,KEEP),VOL=(,,99),
// UNIT=(&LOGT,,DEFER,SEP=IEFRDRE),
// DCB=(RECFM=VB,BLKSIZE=4096,
// LRECL=4092,BUFNO=2)
//SYSOUT DD SYSOUT=&SOUT,SPACE=(CYL,(1,1)),
// DCB=(LRECL=133,RECFM=FBA,BLKSIZE=665)
//SYSUDUMP DD SYSOUT=&SOUT,
// DCB=(LRECL=121,RECFM=FBA,BLKSIZE=3025),
// SPACE=(3025,(200,100),RLSE,,ROUND)
//CEEDUMP DD SYSOUT=&SOUT,
// DCB=(LRECL=121,RECFM=FBA,BLKSIZE=3025),
// SPACE=(3025,(200,100),RLSE,,ROUND)

```

Usage

For a job step declaring database-update intent, DD DUMMY can be specified if the job step is not using DBRC. This is valid where an image copy of the database is taken before the update job step.

Log initialization calculates the smallest value necessary for logical record length. If the JCL logical record length value is larger than the calculated value, the JCL value is used; otherwise, log initialization uses the calculated value for logical record length and adds 4 for the block size.

If multiple volumes are required for the system log, a volume count value should be specified in the VOL parameter of the DD statement.

If the IBM 3480 tape drive is used for the IMS log data set, IMS forces tape write mode (DCB=OPCD=W). The default on the 3480 is to hold the write in a buffer so that IMS cannot detect when the write is performed. If a power failure occurs after a log record is written to the 3480, and the database is updated but the log record is not yet written to tape, database integrity is lost. Tape write mode is forced for the log in batch and GSAM data sets.

In the sample IMSCOBGO procedure that is built during SMP/E processing and placed in the ADFSPROC and SDFSPROC library data sets, the IEFORDER2 DD statement is included as a comment. To use the IEFORDER2 DD statement, remove the asterisks (*).

Parameters

The following parameters are valid for the IMSCOBGO procedure.

BKO=
BUF=
CKPTID=
DBRC=
DBRCGRP=
EXCPVR=
FMTO=
IMSID=
IN=
IMSPLEX=
IRLM=
IRLMNM=
JOB=
LOGA=
LOGT=
MBR=
MON=
NODE1=
NODE2=
PRLD=
PSB=
RGN=
SOUT=
SPIE=
SRCH=
SWAP=
SYS2=
TEST=

See [“Parameter descriptions for IMS procedures”](#) on page 520 for descriptions.

DD statements

The following DD statements are valid for the IMSCOBGO procedure.

In addition to the following DD statements, add statements for data sets representing IMS databases.

DFSHALDB ¹
DFSRESLB DD
DFSSTAT DD
IEFRDER DD
IEFRDER2 DD
IMS DD
PROCLIB DD
RECON_n DD
STEPLIB DD
SYSHALDB DD¹

SYSLIB DD
SYSLIN DD
SYSLMOD DD
SYSOUT DD
SYSPRINT DD
SYSUDUMP DD
SYSUTn DD

See [“DD statement descriptions” on page 583](#) for descriptions.

IMSCOBOL procedure

The IMSCOBOL procedure is a two-step compile and bind procedure for IMS applications that are written in COBOL.

Parameters

The following parameters are valid for the IMSCOBOL procedure. See [“Parameter descriptions for IMS procedures” on page 520](#) for descriptions.

MBR=
SOUT=
SYS2=
NODE1=
NODE2=

DD statements

The following DD statements are valid for the IMSCOBOL procedure. See [“DD statement descriptions” on page 583](#) for descriptions.

DFSRESLB DD
SYSLIB DD
SYSLIN DD
SYSLMOD DD
SYSPRINT DD
SYSUTn DD

JCL

The JCL in [“Sample compile and bind procedure for IMS COBOL” on page 653](#) assumes that:

- You supply source data from SYSIN.
- The output class is A.
- MBR=NAME, where NAME is the load module name for the program.
- SYSDA is a generic device name.

Sample compile and bind procedure for IMS COBOL

```
//      PROC MBR=TEMPNAME,PAGES=60,SYS2=,  
//      LNGPRFX=IGY,  
//      LIBPRFX=CEE,  
//      SOUT=A  
//C     EXEC PGM=IGYCRCTL,REGION=4M,  
//      PARM='SIZE(832K),BUF(10K),LINECOUNT(50)'  
//STEPLIB DD DSN=&LNGPRFX..SIGYCOMP,  
//      DISP=SHR  
//SYSLIN DD DSN=&&LIN,DISP=(MOD,PASS),UNIT=SYSDA,  
//      DCB=(IMS.&SYS2.PROCLIB),  
//      SPACE=(3520,(40,10),RLSE,,ROUND)
```

```

//SYSPRINT DD SYSOUT=&SOUT,
//          DCB=(LRECL=121, BLKSIZE=605, RECFM=FBA),
//          SPACE=(605, (&PAGES.0, &PAGES), RLSE, , ROUND)
//SYSUT1   DD UNIT=SYSDA, SPACE=(CYL, (1,1))
//SYSUT2   DD UNIT=SYSDA, SPACE=(CYL, (1,1))
//SYSUT3   DD UNIT=SYSDA, SPACE=(CYL, (1,1))
//SYSUT4   DD UNIT=SYSDA, SPACE=(CYL, (1,1))
//SYSUT5   DD UNIT=SYSDA, SPACE=(CYL, (1,1))
//SYSUT6   DD UNIT=SYSDA, SPACE=(CYL, (1,1))
//SYSUT7   DD UNIT=SYSDA, SPACE=(CYL, (1,1))
//L        EXEC PGM=IEWL, REGION=4M,
//          PARM='XREF,LET,LIST',
//          COND=(8,LT,C)
//SYSLIB   DD DSN=&LIBPRFX..SCEELKED,
//          DISP=SHR
//SDFSRESL DD DSN=IMS.&SYS2.SDFSRESL, DISP=SHR
//SYSLIN   DD DSN=&&LIN, DISP=(OLD,DELETE),
//          VOL=REF=*..C.SYSLIN
//          DD DISP=SHR,
//          DSN=IMS.&SYS2.PROCLIB(CBLTDLI)
//          DD DDNAME=SYSIN
//SYSLMOD  DD DISP=SHR,
//          DSN=IMS.&SYS2.PGMLIB(&MBR)
//SYSPRINT DD SYSOUT=&SOUT,
//          DCB=(RECFM=FBA, LRECL=121, BLKSIZE=605),
//          SPACE=(605, (&PAGES.0, &PAGES), RLSE, , ROUND)
//SYSUT1   DD UNIT=(SYSDA, SEP=(SYSLMOD, SYSLIN)),
//          DISP=(,DELETE),
//          SPACE=(3520, (100,10), RLSE, , ROUND)

```

IMSDALOC procedure

Use the IMSDALOC procedure to generate the list of databases, DEDB data areas, and data sets that are to be dynamically allocated.

Usage

The IMSDALOC procedure is created as a part of system definition and is placed into the IMS.PROCLIB library by stage two of IMS system definition. This is a three-step procedure for generating the list of databases and DEDB data areas that are to be dynamically allocated.

IMSDALOC assumes that:

- Input is read from SYSIN.
- Each database or DEDB data set described in the input has a corresponding module placed in the dynamic allocation member data set.
- The name given to each module is the name of the database or DEDB data area described in the input.

The dynamic allocation macro statements are supplied as input to the IMSDALOC procedure and executed as a z/OS job.

Step BLDMBR is used with the z/OS IEBUPDTE utility, which incorporates changes to sequential or partitioned data sets.

Refer to the IEBUPDTE utility in *z/OS DFSMSdfp Utilities* for information about this step.

Step LNKEDT is the bind step.

Refer to *MVS/DFP Linkage Editor and Loader* for information about linkage-editors.

Parameters

The following parameters are valid for the IMSDALOC procedure. See [“Parameter descriptions for IMS procedures” on page 520](#) for descriptions.

```

MACSYS=
NODE2=
SOUT=
SYS2=

```

DD statements

The following DD statements are valid for the IMSDALOC procedure are shown below. See [“DD statements for IMS procedures”](#) on page 583.

```
OBJMOD DD
SYSIN DD
SYSLIB DD
SYSLIN DD
SYSLMOD DD
SYSPRINT DD
SYSPUNCH DD
SYSUT1 DD
SYSUT2 DD
```

JCL

The following code is the JCL for the IMSDALOC procedure.

```
//          PROC SOUT=A, SYS2=
//ASSEM   EXEC PGM=ASMA90,
//          PARM='ALIGN, DECK, NOOBJECT, NOBCS'
//SYSLIB  DD DSN=IMS.&SYS2.SDFSMA, DISP=SHR
//          DD DSN=SYS1.MACLIB, DISP=SHR
//SYSUT1  DD UNIT=SYSDA, SPACE=(CYL,(10,5))
//SYSPUNCH DD DSN=&OBJMOD,
//          DCB=(RECFM=FB, LRECL=80, BLKSIZE=400),
//          SPACE=(400,(100,100)), UNIT=SYSDA,
//          DISP=(NEW, PASS)
//SYSPRINT DD SYSOUT=&SOUT
//BLDMBR  EXEC PGM=IEBUPDTE, PARM='NEW',
//          COND=(7, LT, ASSEM)
//SYSPRINT DD DUMMY
//SYSUT2  DD DSN=&TEMPPDS, UNIT=SYSDA,
//          DISP=(NEW, PASS, DELETE),
//          SPACE=(80,(1000,500,10)),
//          DCB=(RECFM=F, BLKSIZE=80)
//SYSIN   DD DSN=*.ASSEM.SYSPUNCH,
//          DISP=(OLD, DELETE, DELETE)
//LNKEDT  EXEC PGM=IEWL, PARM='LIST, XREF, LET',
//          COND=((7, LT, ASSEM), (3, LT, BLDMBR))
//SYSUT1  DD UNIT=SYSDA, SPACE=(1024,(100,50))
//SYSLIB  DD DUMMY
//SYSPRINT DD SYSOUT=&SOUT
//SYSLMOD DD DSN=IMS.&SYS2.SDFSRESL, DISP=SHR
//OBJMOD  DD DSN=&TEMPPDS, DISP=(OLD, DELETE, DELETE)
//SYSLIN  DD DSN=&TEMPPDS(LNKCTL),
//          DISP=(OLD, DELETE, DELETE),
//          VOL=REF=*.OBJMOD
```

Example

The following JCL statement invokes the IMSDALOC procedure.

```
//DALOC   JOB
//*
//STEP    EXEC IMSDALOC
//*
//SYSIN   DD *
          DFSMDA TYPE=
          END
/*
```

IMSFP procedure

The IMSFP procedure is an online procedure that initiates a Fast Path region where Fast Path applications run.

Non-message-driven Fast Path applications are not supported and should be changed to run as BMPs, using the IMSBATCH procedure. See [“IMSBATCH procedure” on page 648](#).

Parameters

The following parameters are valid for the IMSFP procedure.

See [“Parameter descriptions for IMS procedures” on page 520](#) for descriptions.

AGN=
ALTID=
APARM=
CPUTIME=
DBLDL=
DIRCA=
ENVIRON=
IMSID=
JVM=
JVMOPMAS=
LOCKMAX=
MBR=
NBA=
NODE1=
NODE2=
OBA=
OPT=
PARDLI=
PREINIT=
PRLD=
PSB=
RGN=
SOD=
SOUT=
SSM=
STIMER=
SYS2=
TLIM=

DD statements

The following DD statements are valid for the IMSFP procedure. See [“DD statement descriptions” on page 583](#) for descriptions.

DFSESL (optional)
PROCLIB DD
STEPLIB DD
SYSUDUMP DD

Sample procedure to execute a Fast Path application program

The procedure shown here executes a Fast Path region where Fast Path applications run. The IFP, &MBR, &PSB, &NBA, &OBA, &OPT parameters are positional.

```
//IFPROC PROC MBR=TEMPNAME,SOUT=A,RGN=100K,OPT=N,
//          PSB=,NBA=000,OBA=000,TLIM=1,
//          DIRCA=000,PRLD=,STIMER=0,SOD=,DBLDL=,
//          CPUTIME=,IMSID=,AGN=,SSM=,PREINIT=,
//          SYS2=,ALTID=,APARM=,LOCKMAX=,
//          ENVIRON=,JVMOPMAS=,PARDLI=
//IFP EXEC PGM=DFSRR00,REGION=&RGN,
//      TIME=1440,
//      PARM=(IFP,&MBR,&PSB,&NBA,&OBA,&OPT,
//      &TLIM,&DIRCA,&PRLD,&STIMER,&SOD,&DBLDL,
//      &CPUTIME,&IMSID,&AGN,&SSM,&PREINIT,
//      &ALTID,'&APARM',&LOCKMAX,&ENVIRON,
//      &JVMOPMAS,&PARDLI)
//STEPLIB DD DSN=IMS.&SYS2.SDFSRESL,DISP=SHR
//      DD DSN=IMS.&SYS2.PGMLIB,DISP=SHR
//PROCLIB DD DSN=IMS.&SYS2.PROCLIB,DISP=SHR
//SYSUDUMP DD SYSOUT=&SOUT,
//      DCB=(LRECL=121,RECFM=VBA,BLKSIZE=3129),
//      SPACE=(125,(2500,100),RLSE,,ROUND)
```

Sample procedure to execute a Fast Path application program with JVM=3164

```
//IFPROC PROC MBR=TEMPNAME,SOUT=A,RGN=100K,OPT=N,
//          PSB=,NBA=000,OBA=000,TLIM=1,
//          DIRCA=000,PRLD=,STIMER=0,SOD=,DBLDL=,
//          CPUTIME=,IMSID=,AGN=,SSM=,PREINIT=,
//          SYS2=,ALTID=,APARM=,LOCKMAX=,
//          ENVIRON=,JVMOPMAS=,PARDLI=,JVM=3164
//IFP EXEC PGM=DFSRR00,REGION=&RGN,
//      TIME=1440,
//      PARM=(IFP,&MBR,&PSB,&NBA,&OBA,&OPT,
//      &TLIM,&DIRCA,&PRLD,&STIMER,&SOD,&DBLDL,
//      &CPUTIME,&IMSID,&AGN,&SSM,&PREINIT,
//      &ALTID,'&APARM',&LOCKMAX,&ENVIRON,
//      &JVMOPMAS,&PARDLI,&JVM)
//STEPLIB DD DSN=IMS.&SYS2.SDFSRESL,DISP=SHR
//      DD DSN=IMS.&SYS2.SDFSJLIB,DISP=SHR
//      DD DSN=IMS.&SYS2.PGMLIB,DISP=SHR
//PROCLIB DD DSN=IMS.&SYS2.PROCLIB,DISP=SHR
//SYSUDUMP DD SYSOUT=&SOUT,
//      DCB=(LRECL=121,RECFM=VBA,BLKSIZE=3129),
//      SPACE=(125,(2500,100),RLSE,,ROUND)
```

IMSMMSG procedure

The IMSMSG job is used to execute an IMS message processing program.

JCL

The following job executes procedure DFSMPR, which is used to start an online message region. See “DFSMPR procedure” on page 626 for details.

```
//MESSAGE JOB 1,IMS,MSGLEVEL=1,PRTY=11,CLASS=K,MSGCLASS=A,REGION=56K
//      EXEC DFSMPR,
//      IMSID=
```

IMSPLI procedure

The IMSPLI procedure is a two-step compile and bind procedure for IMS applications written in PL/I.

“Sample JCL for the IMSPLI procedure” on page 658 demonstrates the IMSPLI procedure. This sample procedure assumes that:

- Your supply source data is from SYSIN.

- The output class is A.
- MBR=NAME, where NAME is the load module name for the program.
- SYSDA is a generic device name.

Parameters

The following parameters are valid for the IMSPLI procedure. See [“Parameter descriptions for IMS procedures”](#) on page 520 for descriptions.

```

MBR=
NODE1=
NODE2=
SPIE=
SYS2=

```

DD statements

The following DD statements are valid for the IMSPLI procedure. See [“DD statement descriptions”](#) on page 583 for descriptions.

```

DFSRESLB DD
SYSLIB DD
SYSLIN DD
SYSLMOD DD
SYSPRINT DD
SYSUT1 DD

```

Sample JCL for the IMSPLI procedure

```

//          PROC MBR=TEMPNAME,PAGES=50,SYS2=,
//          LNGPRFX=IEL,
//          LIBPRFX=CEE,
//          SOUT=A
//C        EXEC PGM=IEL1AA,REGION=4M,
//          PARM=(XREF,A,OBJ,NODECK,NOMACRO,,
//          'OPT(TIME)')
//STEPLIB DD DSN=&LNGPRFX..SIELCOMP,DISP=SHR
//          DD DSN=&LIBPRFX..SCEERUN,DISP=SHR
//SYSUT1  DD UNIT=SYSDA,
//          SPACE=(1024,(200,50),RLSE,,ROUND),
//          DCB=BLKSIZE=1024,DISP=(,DELETE)
//SYSPRINT DD SYSOUT=&SOUT,
//          DCB=(LRECL=125,BLKSIZE=629,RECFM=VBA),
//          SPACE=(605,(&PAGES.0,&PAGES),RLSE)
//SYSLIN  DD UNIT=SYSDA,SPACE=(80,(250,100),RLSE),
//          DCB=(IMS.&SYS2.PROCLIB),
//          DISP=(,PASS)
//L        EXEC PGM=IEWL,PARM='XREF,LIST,LET',
//          COND=(9,LT,C),REGION=4M
//SYSLIB  DD DSN=&LIBPRFX..SCEELKED,DISP=SHR
//SDFSRESL DD DSN=IMS.&SYS2.SDFSRESL,DISP=SHR
//SYSLIN  DD DSN=* .C.SYSLIN,DISP=(OLD,DELETE)
//          DD DISP=SHR,
//          DSN=IMS.&SYS2.PROCLIB(PLITDLI)
//          DD DDNAME=SYSIN
//SYSLMOD DD DISP=SHR,
//          DSN=IMS.&SYS2.PGMLIB(&MBR)
//SYSPRINT DD SYSOUT=&SOUT,
//          DCB=(LRECL=121,RECFM=FBA,BLKSIZE=605),
//          SPACE=(605,(&PAGES.0,&PAGES),RLSE)
//SYSUT1  DD UNIT=SYSDA,DISP=(,DELETE),
//          SPACE=(CYL,(5,1),RLSE)

```

IMSPLIGO procedure

The IMSPLIGO procedure is a three-step compile, bind, and go procedure combining the IMSPLI procedure with an execution step for a stand-alone DL/I batch processing region.

If VSAM databases are used, see [“IMS buffer pools”](#) on page 206.

JCL

The IMSPLIGO procedure is shown in the following sample. This sample procedure assumes that:

- You supply source data from SYSIN.
- The output class is A.
- MBR=NAME, where NAME is the load module name for the program.
- SYSDA is a generic device name.
- You add DD statements for data sets representing IMS databases.

```
//      PROC MBR=TEMPNAME,PAGES=50, SYS2=,
//      LNGPRFX=IEL,
//      LIBPRFX=CEE,
//      SOUT=A,RGN=4M,
//      PSB=,BUF=7,SPIE=0,TEST=0,EXCPVR=0,
//      RST=0,PRLD=,SRCH=,CKPTID=,MON=N,
//      LOGA=0,FMT0=T,IMSID=,SWAP=,RGN=4M,
//      LOGT=2400,
//      DBRC=,IRLM=,IRLMNM=,BKO=N,IOB=,
//      SSM=,APARM=,LOCKMAX=,IMSPLEX=
//C      EXEC PGM=IEL1AA,REGION=4M,
//      PARM=(XREF,A,OBJ,NODECK,NOMACRO,,
//      'OPT(TIME)')
//STEPLIB DD DSN=&LNGPRFX..SIELCOMP,DISP=SHR
//      DD DSN=&LIBPRFX..SCEERUN,DISP=SHR
//SYSUT1  DD UNIT=SYSDA,
//      SPACE=(1024,(200,50),RLSE,,ROUND),
//      DCB=BLKSIZE=1024,DISP=(,DELETE)
//SYSPRINT DD SYSOUT=&SOUT,
//      DCB=(LRECL=125,BLKSIZE=629,RECFM=VBA),
//      SPACE=(605,(&PAGES.0,&PAGES),RLSE)
//SYSLIN  DD UNIT=SYSDA,SPACE=(80,(250,100),RLSE),
//      DCB=(IMS.&SYS2.PROCLIB),
//      DISP=(,PASS)
//L      EXEC PGM=IEWL,PARM='XREF,LIST,LET',
//      COND=(9,LT,C),REGION=4M
//SYSLIB  DD DSN=&LIBPRFX..SCEELKED,DISP=SHR
//SDFSRESL DD DSN=IMS.&SYS2.SDFSRESL,DISP=SHR
//SYSLIN  DD DSN=*.C.SYSLIN,DISP=(OLD,DELETE)
//      DD DISP=SHR,
//      DSN=IMS.&SYS2.PROCLIB(PLITDLI)
//      DD DDNAME=SYSIN
//SYSLMOD DD DISP=SHR,
//      DSN=IMS.&SYS2.PGMLIB(&MBR)
//SYSPRINT DD SYSOUT=&SOUT,
//      DCB=(LRECL=121,RECFM=FBA,BLKSIZE=605),
//      SPACE=(605,(&PAGES.0,&PAGES),RLSE)
//SYSUT1  DD UNIT=SYSDA,DISP=(,DELETE),
//      SPACE=(CYL,(5,1),RLSE)
```

```
//G      EXEC PGM=DFSRR00,REGION=&RGN,TIME=5,
//      COND=(9,LT),
//      PARM=(DLI,&MBR,&PSB,&BUF,
//      &SPIE&TEST&EXCPVR&RST,
//      &PRLD,&SRCH,&CKPTID,&MON,&LOGA,
//      &FMT0,&IMSID,&SWAP,&DBRC,&IRLM,
//      &IRLMNM,&BKO,&IOB,&SSM,'&APARM',
//      &LOCKMAX,,&IMSPLEX)
//STEPLIB DD DSN=IMS.&SYS2.SDFSRESL,DISP=SHR
//      DD DSN=IMS.&SYS2.PGMLIB,DISP=SHR
//      DD DSN=&LIBPRFX..SCEERUN,DISP=SHR
//SDFSRESL DD DSN=IMS.&SYS2.SDFSRESL,DISP=SHR
//IMS     DD DSN=IMS.&SYS2.PSBLIB,DISP=SHR
//      DD DSN=IMS.&SYS2.DBDLIB,DISP=SHR
//PROCLIB DD DSN=IMS.&SYS2.PROCLIB,DISP=SHR
```

```
//IEFRDER DD DSN=IMSLOG,DISP=(NEW,KEEP),
//        VOL=(,,,99),UNIT=(&LOGT,,DEFER),
//        DCB=(RECFM=VB,BLKSIZE=4096,
//        LRECL=4092,BUFNO=2)
//IEFRDER2 DD DSN=IMSLOG2,DISP=(NEW,KEEP),
//         UNIT=(&LOGT,,DEFER,SEP=IEFRDER),
//         VOL=(,,,99),DCB=(RECFM=VB,BLKSIZE=4096,
//         LRECL=4092,BUFNO=2)
//SYSPRINT DD SYSOUT=&SOUT,
//         DCB=(LRECL=121,BLKSIZE=605,RECFM=FBA),
//         SPACE=(605,(500,500),RLSE,,ROUND)
//SYSUDUMP DD SYSOUT=&SOUT,
//         DCB=(LRECL=121,BLKSIZE=605,RECFM=FBA),
//         SPACE=(605,(500,500),RLSE,,ROUND)
```

Usage

In the JCL provided:

- The parameters are positional.
- The IMS PROCLIB data set should have the same block size as SYS1.PROCLIB, which should be 80, 400, or 3200.
- The IEFRDER and IEFRDER2 statements are not required in DB/DC or DBCTL environments if the job does not declare database update intent.

For a job step declaring database-update intent, DD DUMMY can be specified if the job step is not using DBRC. This is valid where an image copy of the database is taken before the update job step.

The log-initialization process calculates the smallest value necessary for logical record length. If the JCL logical record length value is larger than the calculated value, the JCL value is used; otherwise, the log-initialization process uses the calculated value for logical record length and adds 4 for the block size.

If multiple volumes are required for the system log, a volume count value should be specified in the VOL parameter of the DD statement.

If the IBM 3480 tape drive is used for the IMS log data set, IMS forces tape write mode (DCB=OPCD=W). The default on the 3480 is to hold the write in a buffer so that IMS cannot detect when the write is performed. If a power failure occurs after a log record is written to the 3480, and the database is updated but the log record is not yet written to tape, database integrity is lost. Tape write mode is forced for the log in batch and GSAM data sets.

In the sample IMSPLIGO procedure that is built during SMP/E processing and placed in the ADFSPROC and SDFSPROC library data sets, the IEFRDER2 DD statement is included as a comment. To use the IEFRDER2 DD statement, remove the asterisks (*).

Parameters

The following parameters are valid for the IMSPLIGO procedure. See [“Parameter descriptions for IMS procedures”](#) on page 520 for descriptions.

```
BKO=
BUF=
CKPTID=
DBRC=
DBRCGRP=
EXCPVR=
FMTO=
IMSID=
IMSPLEX=
IOB=
IRLM=
IRLMNM=
LOGA=
```

LOGT=
MBR=
MON=
NODE1=
NODE2=
PRLD=
PSB=
RGN=
RST=
SOUT=
SPIE=
SRCH=
SWAP=
SYS2=
TEST=

DD statements

The following DD statements are valid for the IMSPLIGO procedure. See [“DD statement descriptions” on page 583](#) for descriptions.

DFSHALDB
DFSRESLB DD
DFSSTAT DD
IEFRDER DD
IEFRDER2 DD
IMS DD
PROCLIB DD
RECON_n DD
SYSHALDB DD
SYSLIB DD
SYSLIN DD
SYSLMOD DD
SYSOUT DD
SYSPRINT DD
SYSUDUMP DD
SYSUT1 DD

IMSRDR procedure

The IMSRDR procedure is used to read an IMSMSG job into the operating system job stream from direct access storage devices (DASDs).

The JCL shown in [“Sample DASD procedure to read IMSMSG job” on page 662](#) reads an IMSMSG job into the operating system job stream from direct access storage devices.

Usage

You can use one of the following methods to specify the name for the IMSRDR procedure. If you do not specify a name for the IMSRDR procedure, IMS uses a default name of IMSRDR as the name of the IMSRDR procedure that is started by the **/START REGION** command.

- Specify the **PRDR=** parameter in the DFSPBxxx member of the IMS PROCLIB data set.
- Specify the **PRDR=** parameter in JCL.

A sample IMSRDR procedure is supplied in the ADFSPROC and SDFSPROC library data sets. If you specify the **PRDR=** parameter in the DFSPBxxx member or in JCL, the name of the sample IMSRDR procedure does not change.

Parameters

The following parameters are valid for the IMSRDR procedure. See [“Parameter descriptions for IMS procedures”](#) on page 520 for descriptions.

CLASS=
MBR=
NODE2=
SYS2=

DD statements

The following DD statements are valid for the IMSRDR procedure. See [“DD statement descriptions”](#) on page 583 for descriptions.

IEFRDER DD
SYSIN DD
SYSPRINT DD
SYSUT1 DD
SYSUT2 DD

Sample DASD procedure to read IMSMSG job

```
//          PROC MBR=IMSMSG,CLASS=A,SYS2=  
//IEFPROC EXEC PGM=IEBEDIT  
//SYSPRINT DD DUMMY  
//SYSUT1   DD DDNAME=IEFRDER  
//SYSUT2   DD SYSOUT=(&CLASS,INTRDR),DCB=BLKSIZE=80  
//SYSIN    DD DUMMY  
//IEFRDER  DD DISP=SHR,  
//          DSN=IMS.&SYS2.JOBS(&MBR)
```

RDIBATCH procedure

Use the RDIBATCH procedure to help maintain database availability in failure situations.

The RDI region is used in a block-level data-sharing environment to provide a path from the IRLM to DBRC, which guarantees database availability if a failure occurs. The RDI region accomplishes the following tasks:

- IDENTIFY to the IRLM
- SIGNON to DBRC
- WAIT for an IRLM failure

Usage

If an IRLM fails, its associated RDI region abends with a U3303 abend. The surviving IRLM partner is notified of the failure and notifies DBRC of the failure.

The RDI region can be terminated only by an IRLM failure or by an operator CANCEL command. You must ensure that the IRLM and DBRC are both being used to gain the benefits of data-sharing protection that this region offers.

If you are using IMS with IBM CICS Transaction Server for z/OS in an XRF environment, this procedure is essential. For more information about using IMS with CICS in an XRF environment, see the *CICS Extended Recovery Facility Guide*.

The procedure shown in [“Sample RDIBATCH procedure”](#) on page 663 is not placed in the IMS PROCLIB data set by IMS system definition. You must create it by modifying a copy of either the DBBBATCH or DLIBATCH procedure. The region type is RDI.

Parameters

The following parameters are valid for the RDIBATCH procedure. See [“Parameter descriptions for IMS procedures”](#) on page 520 for descriptions.

APARM=
BKO=
BUF=
CKPTID=
DBRC=
DBRCGRP=
EXCPVR=
FMTO=
IMSID=
IMSPLEX=
IOB=
IRLM=
IRLMNM=
LOCKMAX=
LOGA=
MBR=
MON=
PRLD=
PSB=
RGN=
RST=
SOUT=
SPIE=
SRCH=
SSM=
SWAP=
SYS=
SYS2=
TEST=

DD statements

The following DD statements are valid for the RDIBATCH procedure. See [“DD statement descriptions”](#) on page 583 for descriptions.

DFSRESLB DD
PROCLIB DD
RECON_n DD
STEPLIB DD
SYSABEND DD

Sample RDIBATCH procedure

The following sample procedure demonstrates the RDIBATCH procedure.

In this sample:

1. MBR=xxxxxxx must be specified but does not need to be valid. The specified member does not receive control but must be specified or parameter analysis fails.
2. DBRC=Y is required (specified or used by default).
3. IRLM=Y is required (specified or used by default).
4. IRLMNM=cccc is required (specified or used by default).
5. TIME=1440 is recommended.

```
//      PROC MBR=ANYNAME, 1 PSB=, BUF=,
//      SPIE=0, TEST=0, EXCPVR=0, RST=0, PRLD=,
//      SRCH=0, CKPTID=, MON=, LOGA=0, FMTO=T,
//      IMSID=, SWAP=, DBRC=Y, 2 IRLM=Y, 3
//      IRLMNM=IRLM, 4 BKO=N, IOB=, SSM=, APARM=,
//      RGN=2048K,
//      SOUT=A,
//      SYS=,
//      SYS2=, LOCKMAX=, IMSPLEX=
//G      EXEC PGM=DFSRR00, REGION=&RGN, TIME=1440, 5
//      PARM=( RDI, &MBR, &PSB, &BUF,
//      &SPIE&TEST&EXCPVR&RST, &PRLD,
//      &SRCH, &CKPTID, &MON, &LOGA, &FMTO,
//      &IMSID, &SWAP, &DBRC, &IRLM, &IRLMNM,
//      &BKO, &IOB, &SSM,
//      '&APARM', &LOCKMAX,
//      &GSGNAME, &TMINAME, &RRS,
//      &IMSPLEX, &RGSUF,
//      '&PARM1', '&PARM2' )
//STEPLIB DD DISP=SHR, DSN=IMS.&SYS2.SDFSRESL
//DFSRESLB DD DISP=SHR, DSN=IMS.&SYS2.SDFSRESL
//DFSVSAMP DD DISP=SHR, DSN=IMS.&SYS2.DFSVSAMP
//PROCLIB DD DISP=SHR, DSN=IMS.&SYS.PROCLIB
//RECON1 DD DISP=SHR, DSN=IMS.&SYS.RECON1
//RECON2 DD DISP=SHR, DSN=IMS.&SYS.RECON2
//RECON3 DD DISP=SHR, DSN=IMS.&SYS.RECON3
//SYSABEND DD SYSOUT=&SOUT.
PEND
```

Repository Server procedure

To start the Repository Server (RS), submit a customized RS startup procedure.

Related reading: For information about starting the RS, see [Starting the Repository Server \(Operations and Automation\)](#).

Customize the following sample procedure and then submit it to start an RS.

Sample procedure to initialize an RS address space

```
//FRP12A  PROC RGN=0M, SOUT=A,
//*
//IEFPROC EXEC PGM=BPEINI00, REGION=0M,
//  PARM=' BPEINIT=FRPINI00, BPECFG=BPECONFG, FRPCFG=FRPCONFG '
//*
//STEPLIB DD DSN=RESLIB_dataset_name, DISP=SHR
//*
//PROCLIB DD DSN=PROCLIB_dataset_name, DISP=SHR
//*
//FRPPRINT DD SYSOUT=&SOUT
//SYSPRINT DD SYSOUT=&SOUT
//SYSUDUMP DD SYSOUT=&SOUT
//*
```

Chapter 20. Members of the IMS PROCLIB data set

These topics describe the IMS PROCLIB data set members that can be used in an IMS environment.

Related concepts

[“IMS Syntax Checker” on page 381](#)

The Syntax Checker is an ISPF application that helps you define, verify, and validate parameters and their values in the members of the IMS PROCLIB data set. Use the IMS Syntax Checker to avoid typographical and syntactical errors when modifying the parameter values for the IMS PROCLIB data set members.

[“Specifying comments in IMS PROCLIB data set members processed by the Syntax Checker” on page 388](#)

IMS allows comments to be included in most IMS PROCLIB data set members. Special considerations exist for comments in IMS PROCLIB data set members processed by the Syntax Checker.

BPE configuration parameter member of the IMS PROCLIB data set

Use the BPE configuration parameter member of the IMS PROCLIB data set to define BPE execution environment settings such as tracing, language, and statistics time interval settings for an address space that is being started.

You can use the BPE configuration parameter member of the IMS PROCLIB data set to specify parameters for:

- Whether trace entries are written to an external data set, and the external data set that trace entries are written to if so (EXTTRACE=)
- The language that is used for BPE and IMS component messages (LANG=)
- The trace level settings for BPE and IMS component internal trace tables (TRCLEV=)
- The name of a BPE exit list member of the IMS PROCLIB data set where configuration information for IMS component user exit routines is stored (EXITMBR=)
- The time interval between calls to the BPE statistics exit routines (STATINTV=)
- Whether conditional SRB threads run in SRB mode (CONDSRB=)

Specify the member name by coding `BPECFG=member_name` on the EXEC PARM= statement in the address space startup JCL, as shown in this example:

```
EXEC CQSINIT0,PARM='BPECFG=BPECFGCQ'
```

Avoid coding statements in the BPE configuration member that specify definitions for the same resources multiple times. For example, avoid multiple TRCLEV statements for the same trace table type, or multiple EXITMBR statements for the same IMS component type. BPE uses the last statement that it encounters in the member. Any values that are specified on earlier duplicate statements are ignored. Message BPE0017I is issued for each duplicate statement found.

Environments

The BPE configuration parameter member of the IMS PROCLIB data set can be used whenever you are using an IMS address space that uses BPE, such as CQS, DBRC, ODBM, OM, RM, Repository Server (RS), SCI, and IMS Connect.

BPECFG= EXTTRACE syntax

The EXTTRACE parameter defines the external trace data set to IMS.

EXTTRACE statement

➔ EXTTRACE(— GDGDEF(— DSN(*data_set_name*) —) →

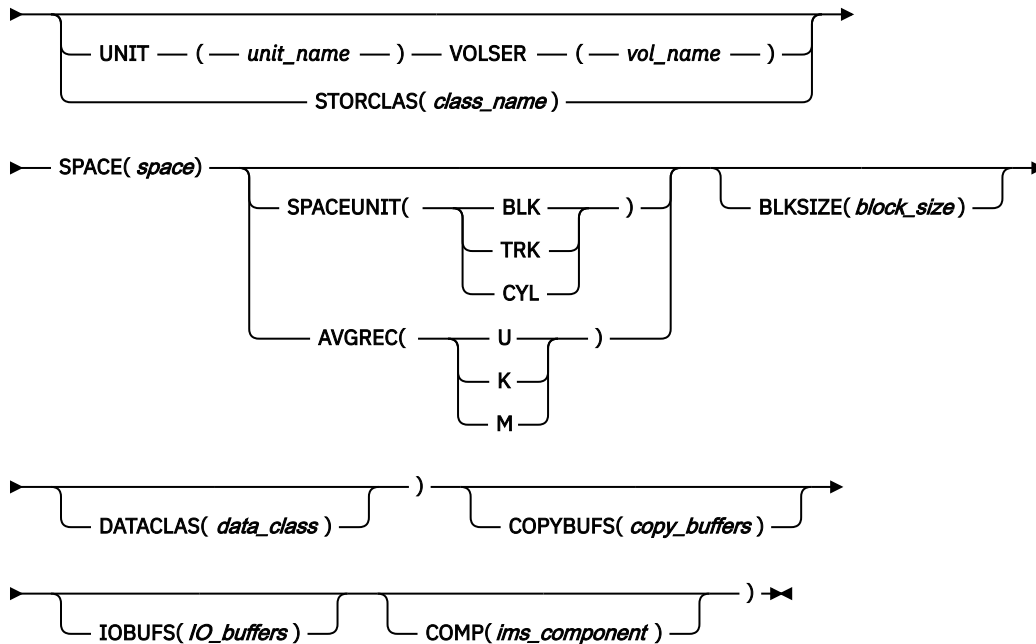

Usage

If you do not include the COMP keyword, the EXTTRACE statement applies to all address spaces that use the current BPE configuration parameter member (BPECFG=) of the IMS PROCLIB data set and do not have a separate EXTTRACE statement. For example, you can define one EXTTRACE statement for CQS address spaces and another for all other address spaces:

```
EXTTRACE ( GDGDEF ( ... ) )
EXTTRACE ( GDGDEF ( ... ) COMP(CQS) )
```

If you have an EXTTRACE statement that is shared by more than one address space, use dynamic system symbols to make the GDG name unique for each address space. If two or more address spaces use the same GDG name, only one of them can allocate and open the data set at a time. If a BPE address space attempts to allocate a GDG data set that is already in use by another address space, the dynamic allocation fails with a return code 00000004, reason code 02100000, indicating that the data set is allocated by another job. To allow the GDG data set to be used by the second address space, stop the first address space's external tracing. This causes the first address space to deallocate the GDG name so that the second address space can allocate it.

BPECFG= EXTTRACE parameters

BLKSIZE

Specifies the block size for the data set. The maximum allowable decimal value for block size is 32 760.

Recommendation: Although the minimum supported block size is 8340, use a large block size or the maximum block size. Using a large block size is more efficient (multiple records are written per block). In addition, your BPE external trace definitions do not have to be changed if the minimum supported block size is ever increased.

COMP

Specifies the IMS component to which the current EXTTRACE statement applies. Values include:

CQS

Specifies that the current EXTTRACE statement applies only to CQS address spaces.

DBRC

Specifies that the current EXTTRACE statement applies only to DBRC address spaces.

HWS

Specifies that the current EXTTRACE statement applies only to IMS Connect address spaces.

ODBM

Specifies that the current EXTTRACE statement applies only to ODBM address spaces.

OM

Specifies that the current EXTTRACE statement applies only to OM address spaces.

REPO

Specifies that the current EXTTRACE statement applies only to RS address spaces.

RM

Specifies that the current EXTTRACE statement applies only to RM address spaces.

SCI

Specifies that the current EXTTRACE statement applies only to SCI address spaces.

COPYBUFS

Specifies the number of buffers that are used to copy the trace table entries from the BPE tables. IMS copies the data from these buffers into the buffers that are specified by the IOBUFS keyword.

The values for this keyword can be 1 - 64000. The default value is 15.

DATACLAS

Specifies the data class for the data set.

If you specify a value for this parameter, the specified data class must have attributes DSORG=PS and RECFM=VB.

GDGDEF

Specifies the generation data group (GDG) data set for the external trace. For general information about GDGs, see *z/OS MVS JCL Reference*. For specific information about defining GDGs for BPE external tracing, see *IMS Version 15.4 System Administration*.

DSN

Specifies the GDG data set name. This data set name does not include absolute or relative generation numbers. You can create the data set on DASD or you can specify a system-managed storage (SMS) class to manage the data set.

Any static or dynamic z/OS system symbol can be specified in the data set name. This includes all static system symbols that you specify by using SYMDEF in an IEASYMxx PARMLIB member. For example, the dynamic system symbol &JOBNAME . can be used to include the job name of the BPE address space in the GDG data set name. Specifying DSN (IMSTESTL . &JOBNAME . . GDG) results in a data set name IMSTESTL . SCI1 . GDG for the BPE SCI1 address space. For more information about system symbols, see the topic "Sharing PARMLIB definitions" in *z/OS MVS Initialization and Tuning Reference*.

In addition to the z/OS system symbols, the BPE-defined symbols that are described in the following table can also be specified in the data set name.

Name of symbol	Length of symbol name	Symbol value	Length of symbol value	Example
&BPEUTYPE.	10	Component type	4 (maximum)	USRID01 . GDG . SCI . USRID01 . GDG . SCI
&BPESNAME.	10	Component system name	8 (maximum)	USRID01 . GDG . CQS1CQS . USRID01 . GDG . C QS

The value of the &BPEUTYPE . symbol is the name of the IMS component that is writing to the external trace data set. Possible values for &BPEUTYPE . are:

CQS

Common Queue Server address space

DBRC

Database Recovery Control address space

HWS

IMS Connect address space

ODBM

Open Database Manager address space

OM

Operations Manager address space

REPO

Repository Server (RS) address space

RM

Resource Manager address space

SCI

Structured Call Interface address space

The value of the &BPESNAME . symbol is the system name that is specified by the IMS component. This system name is appended to the end of most messages that are issued by most IMS components that run in a BPE address space. The system name for each IMS component is as follows:

CQS

For CQS address spaces, the system name is the CQS SSN appended with "CQS." For example, a CQS with SSN=CQS1 has a system name of CQS1CQS.

DBRC

For DBRC address spaces, the system name is "DBRC" appended with the IMSID of the DBRC. For example, a DBRC with an IMSID of "IMS1" has a system name of DBRCIMS1.

HWS

IMS Connect address spaces do not have a BPE system name. If you specify &BPESNAME . for an IMS Connect address space, the symbol is replaced with a null value. For example, the data set name USRID01 . GDG . \$&BPESNAME . resolves to USRID01 . GDG . \$ for an IMS Connect address space.

ODBM

For ODBM address spaces, the system name is the ODBMNAME, as specified on the CSLDIxxx initialization member of the IMS PROCLIB data set, which is appended with "OD." For example, an ODBM with ODBMNAME=ODBM1 has a system name of ODBM1OD.

OM

For OM address spaces, the system name is the OMNAME appended with "OM." For example, an OM with OMNAME=OM1 has a system name of OM1OM.

RP

For RS address spaces, the system name is the RSNAME, as specified on the FRPCFG member of the IMS PROCLIB data set, which is appended with "RP". For example, an RS with RSNAME=ABC1, has a system name of ABC1RP.

RM

For RM address spaces, the system name is the RMNAME appended with "RM." For example, an RM with RMNAME=RM1 has a system name of RM1RM.

SCI

For SCI address spaces, the system name is the SCINAME appended with "SCI." For example, an SCI with SCINAME=SCI1 has a system name of SCI1SCI.

You cannot override the data control block (DCB) attributes for the data set. The disposition for the data set is new (DISP=NEW).

IOBUFS

Specifies the number of buffers that IMS uses to copy data into the external trace data sets.

The values for this keyword can be 1 - 10. The default value is 2.

SPACE

Specifies the number of units of space to be allocated for the data set.

SPACEUNIT

Specifies the quantity of the space for the data in blocks (BLK), tracks (TRK), or cylinders (CYL).

AVGREC

Determines the size of the data set allocation. Values are:

U

Use the space quantity that is specified on the SPACE operand.

K

Multiply the space quantity that is specified on the SPACE operand by 1024 (1 KB).

M

Multiply the space quantity that is specified on the SPACE operand by 1 048 576 (1 MB).

STORCLAS

Specifies the storage class for the data set.

UNIT

Specifies the unit or device type for the data set.

VOLSER

Specifies the volume for the data set.

To enable the data set to use extended address volumes (EAVs), specify an EAV volume.

Restriction: EAVs are available only in z/OS V1.12 or later.

BPECFG= LANG syntax

The LANG parameter specifies the language that is used for BPE and IMS component message text. ENU is for US English, which is the only supported language.

►► LANG=ENU ◄◄

BPECFG= TRCLEV syntax

The TRCLEV parameter specifies:

- The trace level for a trace table.
- Optionally, the number of storage pages that are allocated for the trace table.
- Whether entries made to a trace table are written to an external data set.

TRCLEV controls the level of tracing (the amount of detail traced) for each specified trace table type. BPE-managed trace tables are areas in storage where BPE, and the IMS component that uses BPE, can trace diagnostic information about events occurring within the address space.

►► TRCLEV= →

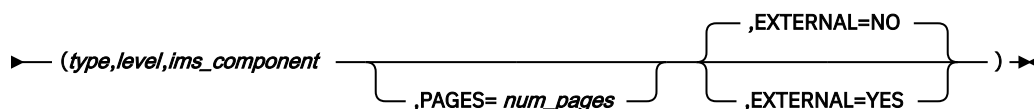

Usage

BPE-managed trace table entries are written either to memory only, or to both memory and external data sets. IMS writes trace entries to external data sets only if you define the data sets to IMS by using the EXTTRACE parameter.

Some trace table types are defined and owned by BPE itself. These are known as *system trace tables*, and are present in all IMS component address spaces that use BPE. The IMS component can also define its own trace tables. These are known as component trace tables or user-product trace tables, and are only present in address spaces of the defining IMS component. For example, trace table types that are defined by Common Queue Server (CQS) are only present in a CQS address space.

You can share one BPE configuration parameter member of the IMS PROCLIB data set among several different IMS component address spaces. Any TRCLEV statements you code for system trace tables apply identically to all the address spaces that share the member. TRCLEV statements for a particular IMS component trace table are processed only by address spaces running that component. For example, you could have a BPE configuration parameter member of the IMS PROCLIB data set containing TRCLEV statements for BPE, CQS, and Resource Manager (RM) trace table types. When you start a CQS address space, only the BPE and CQS TRCLEV statements are processed. When you start an RM address space, only the BPE and RM TRCLEV statements are processed.

BPECFG= TRCLEV parameters

type

Specifies the type of trace table. A trace table's type refers to the events that are traced into that table. For example, the BPE DISP trace table contains entries that are related to events in the BPE dispatcher.

Specifying an asterisk (*) as the type sets the default trace level (and optionally, the default number of pages per trace table) for all trace table types. If you use an asterisk (*) type, make sure that it is the first TRCLEV statement in your member. You can then code additional TRCLEV statements for specific trace table types to selectively override the defaults.

Recommendation: Code a TRCLEV statement with a type of asterisk (*), specifying a level of at least LOW as your first TRCLEV statement for trace table types. This ensures that at least some tracing is done for all trace tables. Specifying a TRCLEV of asterisk (*) also ensures that any new trace table types that are activated in the future are turned on in your system, even if you have not modified your BPE configuration parameter member to explicitly add a TRCLEV statement.

Trace table types that require explicit commands are not processed if an asterisk (*) is specified. To configure trace table types that require explicit commands, include a separate TRCLEV statement that explicitly identifies the table. For example: TRCLEV=(RCTR, MEDIUM, HWS).

The trace table types for each IMS component supported by BPE are shown below.

BPE trace table types

BPE provides a set of trace table types for tracing processing within BPE functions. These BPE trace table types are present in all IMS component address spaces. TRCLEV statements specifying a component of BPE are processed for all IMS component address space types.

Specifying an asterisk (*) sets the default trace level (and, optionally, the default number of pages per trace table) for all BPE-defined trace table types, except for those requiring explicit commands.

AWE

The asynchronous work element (AWE) services trace table shows details of AWE server creation and deletion and AWE processing requests. The default number of pages for this table is 6.

CBS

The control block services trace table traces requests for control block storage. The default number of pages for this table is 6.

CMD

The command trace table traces the first 48 characters of each command that is processed by BPE. The default number of pages for this table is 2.

DISP

The dispatcher trace table traces BPE dispatcher activity. The default number of pages for this table is 8.

ERR

The error trace table traces error events within a BPE address space. The default number of pages for this table is 2.

Restriction: You cannot set the level for the ERR trace table. BPE forces the level to HIGH to ensure that error diagnostics are captured. Any level that you specify for the ERR trace table is ignored. You can, however, specify the number of pages for the ERR trace table on the TRCLEV statement.

ERRV

This table contains variable-length BPE error entries that occur within the BPE address space. The default number of pages for this table is 8.

HASH

The hash trace table traces events that are related to BPE hash table services. Currently, only OM, RM, and SCI address spaces request hash table services. For address spaces that do not use the BPE hash table services, this TRCLEV statement is ignored. The default number of pages for this table is 8.

LATC

The latch trace table traces BPE latch management (serialization) activity. The default number of pages for this table is 8.

SSRV

The system services trace table traces general BPE system service calls. The default number of pages for this table is 4.

STG

The storage service trace table traces storage service requests. The default number of pages for this table is 8.

USRX

The user exit routine trace table traces activity that is related to exit routines (for example, loads, calls, or abends). The default number of pages for this table is 4.

CQS trace table types

CQS provides a set of trace table types for tracing processing within the CQS address space. These CQS trace table types are present only in a CQS address space. TRCLEV statements specifying a component of CQS are ignored for any other address space type.

Specifying an asterisk (*) sets the default trace level (and, optionally, the default number of pages per trace table) for all CQS-defined trace table types, except for those requiring explicit commands.

CQS

The CQS trace table traces general activity that is not related to a specific structure. The default number of pages for this table is 4.

ERR

The error trace table traces error events within a CQS address space. The default number of pages for this table is 4.

Restriction: You cannot set the level for the ERR trace table. BPE forces the level to HIGH to ensure that error diagnostics are captured. Any level that you specify for the ERR trace table is ignored. You can, however, specify the number of pages for the ERR trace table on the TRCLEV statement.

INTF

The interface trace table traces activity in the interface between a CQS and its client. The default number of pages for this table is 8.

OFLW

The overflow event trace table includes activity that is related to CQS structure overflow events. CQS defines one OFLW trace table for each structure pair that is defined to CQS. Trace entries in this table are 64 bytes long. The default number of pages for this table is 12.

SEVT

The structure event trace table includes activity that is related to CQS structure events. CQS defines one SEVT trace table for each structure pair that is defined to CQS. Trace entries in this table are 64 bytes long. The default number of pages for this table is 12.

STR

The client event trace table includes CQS client activity events. CQS defines one STR trace table for each structure pair that is defined to CQS. The default number of pages for this table is 8.

DBRC trace table types

A DBRC address space that is using the Base Primitive Environment defines the following values for DBRC-owned trace tables:

*

By specifying an asterisk (*), you can set the default trace level (and optionally, the default number of pages per trace table) for all DBRC-defined trace table types, except for those requiring explicit commands.

ERR

This table is used to trace errors that occur within the DBRC address space. The default number of pages for this table is 2.

Restriction: You cannot set the level for the ERR trace table. BPE forces the level to HIGH to ensure that error diagnostics are captured. Any level that you specify for the ERR trace table is ignored. You can, however, specify the number of pages for the ERR trace table on the TRCLEV statement.

GRPS

This table is used for DBRC group services message and notification tracing. The default number of pages for this table is 8.

MODF

This table is used for DBRC module flow tracing. The default number of pages for this table is 8.

RQST

This table is used for general DBRC request processing. The default number of pages for this table is 8.

IMS Connect trace table types

IMS Connect defines its own trace tables by using a set of trace table types for tracing processing within IMS Connect functions. These tables are known as component trace tables or user-product trace tables. You can code the following values for IMS Connect-defined trace tables:

*

Specifying an asterisk (*) sets the default trace level (and optionally, the default number of pages per trace table) for all IMS Connect-defined trace table types, except for those requiring explicit commands.

ADPT

Adapter trace table.

CMDT

The command trace table traces IMS Connect command activity. The default number of pages for this table is 2.

CPDR

CICSPORT driver trace table.

CPRT

CICSPORT communication trace table.

ENVT

The interface trace table traces activity in the interface between an IMS Connect and its client. The default number of pages for this table is 2.

ERRV

This table contains variable-length IMS Connect error entries that occur within the BPE address space.

GSVC

General service trace table.

HWSI

The IMS Connect to OTMA driver trace table traces communication activity between IMS Connect and OTMA drivers. The default number of pages for this table is 2.

HWSN

The IMS Connect to local option driver trace table traces communication activity and event between local option driver and IMS Connect. The default number of pages for this table is 2.

HWSO

The IMSplex driver (IPDC) trace table traces communication activity and events between the IMSplex driver and IMS Connect. The default number of pages for this table is 2.

HWSW

The IMS Connect to TCP/IP driver trace table traces communication activity and events between TCP/IP drivers and IMS Connect. The default number of pages for this table is 2.

ICDR

IMS Connect to IMS Connect driver trace table.

ICNC

IMS Connect to IMS Connect communication trace table.

ISCC

ISC communication trace table.

ISDR

ISC driver trace table.

LEPS

Language Environment® (LE) preinitialization services trace table.

MSCC

MSC communication trace table.

MSDR

MSC driver trace table.

ODBM

ODBM communication trace table.

ODDR

ODBM driver trace table.

OMDR

The IMSplex driver (IPDC) trace table traces communication protocol activity (SCI calls). The default number of pages for this table is 2.

OSDR

ODBM socket driver trace table.

OSOC

ODBM socket communication trace table.

OTMA

The OTMA communication driver trace table traces internal communication protocol activity (z/OS cross-system coupling facility calls). The default number of pages for this table is 2.

PCDR

The local option driver trace table traces local option communication protocol activity. The default number of pages for this table is 2.

PCIF

PC interface trace table.

RCDR

RMTICICS driver trace table.

RCIC

RMTICICS communication trace table.

RCTR

The Recorder trace table is used to reroute variable-length recorder trace data to the BPE external trace data set. When the trace level for a Recorder trace table is set to LEVEL(MEDIUM), trace records are written when data is sent to or received from a user message exit. When the trace level is set to LEVEL(HIGH), records are also written each time IMS Connect sends or receives a TCP/IP message or an OTMA message. The Recorder trace table requires explicit commands.

RRSI

RRS interface trace table.

TCPI

The TCP/IP communication driver trace table traces communication protocol activity (TCP/IP calls). The default number of pages for this table is 2.

ODBM trace table types

An ODBM address space that is using the Base Primitive Environment defines the following values for ODBM-owned trace tables:

Specifying an asterisk (*) sets the default trace level (and, optionally, the default number of pages per trace table) for all ODBM-defined trace table types, except for those requiring explicit commands.

CSL

The Common Service Layer (CSL) trace table is used for routines that are common to all CSL managers. The default number of pages for this table is 4.

ERR

This table is used to trace errors that occur within the ODBM address space. The default number of pages for this table is 4.

Restriction: You cannot set the level for the ERR trace table. BPE forces the level to HIGH to ensure that error diagnostics are captured. Any level that you specify for the ERR trace table is ignored. You can, however, specify the number of pages for the ERR trace table on the TRCLEV statement.

ODBM

This table is used for general ODBM processing. The default number of pages for this table is 4.

PLEX

This table is used for ODBM processing for a specific IMSplex. The default number of pages for this table is 8.

OM trace table types

OM provides a set of trace table types for tracing processing within the OM address space. These OM trace table types are present only in an OM address space. TRCLEV statements specifying a component of OM are ignored for any other address space type.

Specifying an asterisk (*) sets the default trace level (and, optionally, the default number of pages per trace table) for all OM-defined trace table types, except for those requiring explicit commands.

CSL

The Common Service Layer (CSL) trace table is used for routines that are common to all CSL managers. The default number of pages for this table is 4.

ERR

The error trace table traces error events within an OM address space. The default number of pages for this table is 4.

Restriction: You cannot set the level for the ERR trace table. BPE forces the level to HIGH to ensure that error diagnostics are captured. Any level that you specify for the ERR trace table is ignored. You can, however, specify the number of pages for the ERR trace table on the TRCLEV statement.

OM

The Operations Manager (OM) trace table traces events that are related to general OM processes. The default number of pages for this table is 4.

PLEX

The IMSplex trace table traces OM processing for a specific IMSplex. The default number of pages for this table is 8.

RM trace tables

RM provides a set of trace table types for tracing processing within the RM address space. These RM trace table types are present only in an RM address space. TRCLEV statements specifying a component of RM are ignored for any other address space type.

Specifying an asterisk (*) sets the default trace level (and, optionally, the default number of pages per trace table) for all RM-defined trace table types, except for those requiring explicit commands.

CSL

The Common Service Layer (CSL) trace table is used for routines that are common to all CSL managers. The default number of pages for this table is 4.

ERR

The error trace table traces error events within an RM address space. The default number of pages for this table is 4.

Restriction: You cannot set the level for the ERR trace table. BPE forces the level to HIGH to ensure that error diagnostics are captured. Any level that you specify for the ERR trace table is ignored. You can, however, specify the number of pages for the ERR trace table on the TRCLEV statement.

REPO

IMSRSC repository trace table traces repository-related processing within the RM address space. The default number of pages for this table is 16.

The RM repository trace can be specified with the **BPE DISPLAY** and **BPE UPDATE TRACETABLE** commands for RM address space traces.

Each RM repository trace table entry is 64 bytes long. The macro CSLRTRC contains the mapping of the RM repository trace table records.

RM

The Resource Manager (RM) trace table traces events that are related to general RM processes. The default number of pages for this table is 4.

PLEX

The IMSplex trace table traces RM processing for a specific IMSplex. The default number of pages for this table is 8.

RS trace table types

The IMS repository function provides a set of trace table types for tracing processing within the RS address space. These trace table types are present only in an RS address space.

Specifying an asterisk (*) sets the default trace level (and, optionally, the default number of pages per trace table) for all RS-defined trace table types, except for those requiring explicit commands.

DIAG

The DIAG trace table contains diagnostic trace entries for the RS. The default number of pages for this table is 4.

SCI trace tables

SCI provides a set of trace table types for tracing processing within the SCI address space. These SCI trace table types are present only in a SCI address space. TRCLEV statements specifying a component of SCI are ignored for any other address space type.

*

Specifying an asterisk (*) sets the default trace level (and, optionally, the default number of pages per trace table) for all SCI-defined trace table types, except for those requiring explicit commands.

CSL

The Common Service Layer (CSL) trace table is used for routines that are common to all CSL address spaces. The default number of pages for this table is 8.

ERPL

The error parameter list trace table traces a copy of the interface parameter list when an error occurs processing an SCI request or message. The default number of pages for this table is 8.

ERR

The error trace table traces error events within an SCI address space. The default number of pages for this table is 4.

Restriction: You cannot set the level for the ERR trace table. BPE forces the level to HIGH to ensure that error diagnostics are captured. Any level that you specify for the ERR trace table is ignored. You can, however, specify the number of pages for the ERR trace table on the TRCLEV statement.

INTF

The interface trace table traces IMSplex member interface activity (requests and messages). The default number of pages for this table is 8.

INTP

The interface parameter trace table traces a copy of the interface parameter list during SCI request and message processing. The default number of pages for this table is 16.

PLEX

The IMSplex trace table traces SCI processing for a specific IMSplex. The default number of pages for this table is 8.

SCI

The Structured Call Interface (SCI) trace table traces events that are related to general SCI processes. The default number of pages for this table is 8.

level

Controls how much tracing is done in the specified trace table. Each trace entry that is made has a level that is associated with the entry. Each trace table has a level setting that is controlled by the value for level that you specify on the TRCLEV statement for the table.

A trace entry is written only if the trace entry's level is less than or equal to the table's level setting. For example, if the trace entry level is MEDIUM, the trace entry is added to the trace table only if the table's level is MEDIUM or HIGH. Thus, the level you specify controls the volume (number) of trace entries that are written to a given table.

A low setting of the level parameter results in fewer trace entries being made to the table. The trace table does not wrap as quickly as with a higher setting (which means that diagnostic information remains available for a longer time), and the performance impact is minimized. However, the trace information is not as detailed as with higher settings, so the captured information might not be sufficient to solve a problem.

A high setting of the level parameter results in more trace entries being written to the table. This can provide additional diagnostic information for solving a problem; however, the trace table tends to wrap more frequently, and higher settings can cause additional CPU usage.

Choose one of the following for the level parameter:

NONE

No tracing.

Recommendation: Do not specify NONE because no tracing, not even tracing for error conditions, is done for the specified table.

ERROR

Only trace entries for error conditions are made. ERROR is the default.

LOW

Low-volume tracing (key component events). This is the minimum recommended trace level setting for normal operation.

MEDIUM

Medium-volume tracing (most component events).

HIGH

High-volume tracing (all component events).

ims_component

Specifies the IMS component that defines the trace table type. Possible values are:

BPE

Indicates that the table is a BPE-defined (system) trace table. BPE trace tables exist in all IMS component address spaces that run with BPE.

CQS

Indicates that the table is a Common Queue Server-defined trace table type.

DBRC

Indicates that the table is a DBRC-defined trace table type.

HWS

Indicates that the table is an IMS Connect-defined trace table type.

ODBM

Indicates that the table is an ODBM-defined trace table type.

OM

Indicates that the table is an Operations Manager-defined trace table type.

REPO

Indicates that the table is a Repository Server-defined trace table type.

RM

Indicates that the table is a Resource Manager-defined trace table type.

SCI

Indicates that the table is a Structured Call Interface-defined trace table type.

PAGES=num_pages

An optional parameter that can be used to specify the number of 4 KB pages to be allocated for the table type.

Specify a value from 1 - 32767 pages for this parameter. If BPE is unable to get the amount of storage you requested for a trace table, it tries to get a smaller number of pages to enable some tracing to be done. You can see the actual number of pages BPE obtained for each trace by issuing the **DISPLAY TRACETABLE** command.

If you do not use this parameter, then the trace table has the default number of pages, as specified under the description of each trace table type.

EXTERNAL=

YES

Specifies that trace entries are written to the external trace data set. However, IMS writes the trace entries only if you define the data set to IMS by using the EXTTRACE statement. If you use the BPE recorder trace facility, you must specify EXTERNAL=YES.

NO

Specifies that trace entries are written only to memory and not to the external trace data set. NO is the default value.

BPECFG= EXITMBR syntax

The EXITMBR parameter specifies the exit list member name. You can specify one EXITMBR= parameter for each IMS component running with BPE, and one EXITMBR= parameter for BPE itself.

►► EXITMBR=(*member_name* ,*ims_component*) ◄◄

BPECFG= EXITMBR parameters***member_name***

Specifies the 1- to 8-character exit list member name.

ims_component

Specifies the IMS component whose user exit routines are being defined. Possible values are:

BPE

Indicates the BPE exit routine member name.

CQS

Indicates the Common Queue Server exit routine member name.

DBRC

Indicates the DBRC exit routine member name.

HWS

Indicates the IMS Connect exit routine member name.

ODBM

Indicates the Open Database Manager (ODBM) exit routine member name.

OM

Indicates the Operations Manager (OM) exit routine member name.

RM

Indicates the Resource Manager (RM) exit routine member name.

SCI

Indicates the Structured Call Interface (SCI) exit routine member name.

BPECFG= STATINTV syntax

The optional STATINTV parameter specifies the time interval, in seconds, between calls to the BPE statistics exit or exit routines. You can set STATINTV from 1 to 2147483647 ($2^{31}-1$). The default STATINTV value is 600 (10 minutes).

►► STATINTV=(*number_of_seconds*) ◄◄

Usage

Specify a STATINTV value of 60 or more to avoid possible performance problems due to frequent exit routine calls.

BPECFG= CONDRSB syntax

Note: This information provides only general descriptions of the types and portions of workloads that are eligible for execution on Specialty Engines (for example, zIIPs, zAAPs, and IFLs) (“SEs”). IBM authorizes customers to use IBM SEs only to execute the processing of Eligible Workloads of specific Programs expressly authorized by IBM as specified in the “Authorized Use Table for IBM Machines” provided at www.ibm.com/systems/support/machine_warranties/machine_code/aut.html (“AUT”). No other workload processing is authorized for execution on an SE. IBM offers SEs at a lower price than

General Processors/Central Processors because customers are authorized to use SEs only to process certain types and/or amounts of workloads as specified by IBM in the AUT.

In IMS 15.4 ("V15.4") and later, certain processing in the IMS Connect address space, the IMS Open Database Manager ("ODBM") address space, and in the IMS Common Queue Server ("CQS") address space, as specified below may, when enclave SRB execution is enabled by a user, be executed under enclave service request blocks ("SRBs"). Enclave SRB execution may be enabled as unconditional;¹ or it may be enabled as conditional, based on the presence of at least one zIIP during address space initialization. When enclave SRB execution is enabled, V15.4 will direct z/OS to authorize such work to be processed on an available zIIP.

Except as otherwise described below, the following IMS Connect and ODBM processing can execute under an enclave SRB in V15.4:

- Processing of IMS Connect address space SOAP message threads for SOAP messages arriving via TCP/IP
- Processing of IMS Connect and ODBM address space Distributed Relational Database Architecture ("DRDA") threads for DRDA requests arriving via TCP/IP.
- Processing of IMS Connect address space Multiple System Coupling ("MSC") threads for MSC messages arriving via TCP/IP
- Processing of IMS Connect address space Intersystem Communication ("ISC") threads for ISC messages arriving via TCP/IP
- Processing of ODBM address space threads for requests arriving through the CSLDMI API
- Processing of CQS address space threads that process CQSREAD and CQSBWSE requests (CQSREAD and CQSBWSE are requests used by CQS clients such as the IMS control region to read and browse data in the CQS message queue and resource structures)

Note that any user exits called by the above processing will not execute under an enclave SRB. User exits are always given control in TCB mode, and such exit instructions are not authorized to be processed on a zIIP. Also note that certain processing cannot, due to technical restrictions, execute under enclave SRBs. Such processing includes calling z/OS Resource Recovery Services ("RRS"), IMS DL/I call processing, and z/OS supervisor calls ("SVCs"). IMS switches from SRB mode into TCB mode to perform such processing, and thus such processing will not execute on a zIIP.

The CONDSRB parameter allows you to specify how BPE manages conditional SRB threads. Using this parameter, you can request BPE to:

- Always run such conditional SRB threads in SRB mode, even if there are no zIIPs online
- Never run such conditional SRB threads in SRB mode, even if there are zIIPs online
- Conditionally run such conditional SRB threads in SRB mode only when there are zIIPs online

The syntax of the parameter is as follows:

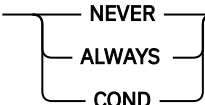
```
➤ CONDSRB=(  ,ims_component ) ➤
```

The first parameter of CONDSRB specifies BPE's behavior for threads in address spaces belonging to the IMS component indicated by the second CONDSRB parameter. There are three possible values for this first parameter:

¹ In an unconditional status, the user may enable such processing to be executed in enclave SRB mode when no zIIP is online or part of the user's System z environment. But, of course, no zIIP utilization could result. A user might request enclave SRB execution even in the absence of zIIPs, to allow the system to project how much work is eligible to run on zIIP and probably would if there were zIIP capacity available. See the PROJECTCPU parameter of the IEAOPTxx SYS1.PARMLIB member in *z/OS MVS Initialization and Tuning Reference* (SA22-7592) for further information.

NEVER

BPE will never run the conditional SRB threads in SRB mode; it will always run them in TCB mode. This is the default behavior, and applies if no CONDSRB statement is coded for an applicable IMS Connect, ODBM, or CQS address space.

Running on a zIIP in SRB mode can reduce software license charges. However, SRB-mode execution is more restrictive than TCB mode. There can be additional processing overhead involved if a thread running in SRB mode has to switch back to TCB mode to perform some processing that is not supported in SRB mode. Additionally, if you have IIPHONORPRIORITY=NO specified in the z/OS IEAOPTxx SYS1.PARMLIB member, ready zIIP-eligible work will wait for a zIIP processor when one is not immediately available, even if there is a standard processor available that could process the work.

Thus, you can use the NEVER setting of CONDSRB to avoid SRB-TCB mode switching overhead, and to force work that could have been zIIP-eligible to run instead on standard processors. No execution on zIIPs will occur for the specified IMS component (for example, IMS Connect, ODBM, or CQS).

For additional information about the IIPHONORPRIORITY parameter, see *z/OS MVS Initialization and Tuning Reference* (SA22-7592).

ALWAYS

BPE will always run conditional SRB threads in SRB mode, even if there were no zIIPs present on the system when BPE services were started (which is typically the time you started the job or started task for the IMS component address space).

If you do not have a zIIP available, you still might want to run the threads in SRB mode. z/OS provides the ability to project the amount of CPU you could have executed on a zIIP had one been installed. You request this projection via the PROJECTCPU parameter of the IEAOPTxx SYS1.PARMLIB member. (See *z/OS MVS Initialization and Tuning Reference* (SA22-7592) for more information.) For this projection to be effective, you must also tell BPE to run the threads in SRB mode always, even when there is no zIIP online.

COND

BPE will run the conditional SRB threads in SRB mode if there was at least one zIIP online at the time BPE services were started. Otherwise, BPE will run the threads in TCB mode, and no utilization of a zIIP for such threads will occur.

The second parameter of CONDSRB specifies the IMS component address space type to which the CONDSRB statement applies. Possible values are:

CQS

Common Queue Server

HWS

IMS Connect

ODBM

Open Database Manager

Note that the CONDSRB statement may be coded for other IMS component address space types; however, no zIIP processing of threads in these address spaces will occur, and the CONDSRB statement will be ignored. Only the specific threads identified in this topic are eligible for execution on a zIIP when using IMS V15.4 and later.

BPECFG= examples

A sample BPE configuration data set for BPE is shown in the example below. This example shows a BPE configuration data set that can be shared by IMS Connect, CQS, CSL, and DBRC. It contains definitions for traces for:

- BPE
- CQS
- DBRC

- IMS Connect
- ODBM
- OM
- RM
- RS
- SCI

It also contains user exit routine list member specifications.

```

*****
* CONFIGURATION FILE FOR BPE
*****

LANG=ENU                /* Language for messages */
                        /* (ENU = U.S. English) */
STATINTV=420            /* STATS user exit interval */
                        /* = 420 seconds (7 minutes) */

#
# Definitions for BPE system traces
#

TRCLEV=(*,LOW,BPE)      /* Set default for all BPE */
                        /* traces to LOW. */
TRCLEV=(AWE,HIGH,BPE)   /* AWE server trace on high */
TRCLEV=(CBS,MEDIUM,BPE) /* Ctrl blk serv trc on medium */
TRCLEV=(DISP,HIGH,BPE,PAGES=12) /* Dispatcher trace on high */
                        /* with 12 pages */

#
# Definitions for IMS Connect traces
#

TRCLEV(RCTR,MEDIUM,HWS,EXT=YES) /* Starts recorder trace */
                                /* facility */

# Definitions for CQS traces
#

TRCLEV=(*,MEDIUM,CQS)    /* Set default for all CQS */
TRCLEV=(STR,HIGH,CQS)    /* traces to medium */
                        /* but run STR trace on high */

# DBRC:

TRCLEV=(*,LOW,DBRC)      /* DEFAULT DBRC TRACES TO LOW */
TRCLEV=(RQST,HIGH,DBRC) /* DBRC GENERAL TRACE ON HIGH */
TRCLEV=(MODF,MEDIUM,DBRC) /* MODULE FLOW TRACE ON MEDIUM*/

#
#
# DEFINITIONS FOR ODBM TRACES - SET DEFAULT FOR ALL ODBM TRACES
# TO LOW, THEN SELETIVELY OVERRIDE THOSE THAT NEED A DIFFERENT
# LEVEL.
#

TRCLEV=(*,LOW,ODBM)      /* DEFAULT ODBM TRACES TO LOW */
TRCLEV=(CSL,HIGH,ODBM)   /* CSL TRACE ON HIGH */
TRCLEV=(ODBM,HIGH,ODBM) /* ODBM GENERAL TRACE ON HIGH */
TRCLEV=(PLEX,HIGH,ODBM) /* IMSPLEX TRACE ON HIGH */
#
#
# Definitions for OM traces
#

TRCLEV=(*,MEDIUM,OM)    /* Set default for all OM */
                        /* traces to medium */

# DEFINITIONS FOR REPOSITORY SERVER TRACES
TRCLEV=(DIAG,HIGH,REPO,PAGES=300) /* DIAG TRACE ON HIGH */

```

```

#
# Definitions for RM traces
#
TRCLEV=(*,MEDIUM,RM)          /* Set default for all RM      */
                               /* traces to medium           */
TRCLEV=(REPO,HIGH,RM,PAGES=300) /* Repo trace on high         */

```

```

#
# Definitions for SCI traces
#
TRCLEV=(*,MEDIUM,SCI)        /* Set default for all SCI    */
                               /* traces to medium           */
TRCLEV=(INTF,HIGH,SCI)       /* Intf call trace on high    */
TRCLEV=(INTP,HIGH,SCI)       /* Intf parmlist trace on high */

```

```

#
# User exit list PROCLIB member specifications
#
EXITMBR=(BPEEXIT0,BPE)       /* BPE user exit definitions  */
EXITMBR=(DBREXIT0,DBRC)     /* DBRC user exit definitions  */
EXITMBR=(CQSEXIT0,CQS)     /* CQS user exit definitions  */
EXITMBR=(OMEXIT00,OM)      /* OM user exit definitions   */
EXITMBR=(RMEXIT00,RM)      /* RM user exit definitions   */
EXITMBR=(SCIEXIT0,SCI)     /* SCI user exit definitions  */
EXITMBR=(CSLEXDM0,ODBM)    /* SPECIFY PROCLIB DATASET   */
                               /* MEMBER CSLEXDM0 AS ODBM'S  */
                               /* USER EXIT LIST MEMBER     */

```

A sample member of the IMS PROCLIB data set with generic and specific EXTTRACE entries is shown in the example below.

You can use z/OS symbolic substitution parameters in the data set name of the BPE external trace GDG data set. This makes a single EXTTRACE specification unique to each address space. For example, you can use the symbol &JOBNAME. in the data set name; it is replaced by the actual address space job name when a BPE address space starts and allocates the external trace data set.

Sample BPE configuration member for a single IMS Connect address space

```

LANG=ENU          /* LANGUAGE FOR MESSAGES      */
                  /* (ENU = U.S. ENGLISH)      */
#
# DEFINITIONS FOR IMS CONNECT TRACES
# HWS:
TRCLEV=(ENVT,MEDIUM,HWS,EXTERNAL=YES)
TRCLEV=(HWSO,HIGH,HWS,EXTERNAL=NO)
TRCLEV=(PLEX,HIGH,ODBM)
TRCLEV=(OMDR,LOW,HWS,EXTERNAL=YES)
TRCLEV=(OTMA,HIGH,HWS,EXTERNAL=YES)

# External trace definitions:
EXTTRACE(GDGDEF(DSN(IMSTESTL.BPETHWS) UNIT(SYSDA) VOLSER(000000)
SPACE(5) ) COMP(HWS) ) /* EXTTRACE specific to IMS Connect address space */

```

Sample BPE configuration with multiple EXTTRACE statements

A sample BPE member of the IMS PROCLIB data set with multiple EXTTRACE statements is shown in the example below.

```

LANG=ENU          /* LANGUAGE FOR MESSAGES      */
                  /* (ENU = U.S. ENGLISH)      */
#
# DEFINITIONS FOR SYSTEM TRACES
#
TRCLEV=(*,LOW,BPE,EXTERNAL=NO)

# CQS:

```

```

TRCLEV=(CQS,MEDIUM,CQS,EXTERNAL=YES)
TRCLEV=(ERR,HIGH,CQS,EXTERNAL=NO)
TRCLEV=(INTF,LOW,CQS,EXTERNAL=YES)
TRCLEV=(STR,HIGH,CQS,EXTERNAL=YES)
TRCLEV=(OFLW,HIGH,CQS,EXTERNAL=YES)
TRCLEV=(SEVT,HIGH,CQS,EXTERNAL=YES)

# SCI:

TRCLEV=(ERR,HIGH,SCI,EXTERNAL=NO)
TRCLEV=(INTF,LOW,SCI,EXTERNAL=YES)
TRCLEV=(INTP,HIGH,SCI,EXTERNAL=YES)
TRCLEV=(SCI,MEDIUM,SCI,EXTERNAL=YES)

# OM:

TRCLEV=(*,LOW,OM,EXTERNAL=YES) /* SET ALL TABLES TO LOW TRACING */

# ODBM:

TRCLEV=(*,LOW,ODBM,EXTERNAL=YES) /* SET ALL TABLES TO LOW TRACING */

# DBRC:

TRCLEV=(*,MEDIUM,DBRC,EXTERNAL=YES) /* SET ALL TABLES TO MEDIUM TRACING */

# External trace definitions:

EXTTRACE(GDGDEF(DSN(IMSTESTL.BPETCQS) UNIT(SYSDA) VOLSER(000000)
SPACE(5) ) COMP(CQS) ) /* <----- EXTTRACE for CQS */

EXTTRACE(GDGDEF(DSN(IMSTESTL.BPETDBRC) UNIT(SYSDA) VOLSER(000000)
SPACE(5) ) COMP(DBRC) ) /* <----- EXTTRACE for DBRC */

EXTTRACE(GDGDEF(DSN(IMSTESTL.BPETSCI) UNIT(SYSDA) VOLSER(000000)
SPACE(5) ) COMP(SCI) ) /* <----- EXTTRACE for SCI */

EXTTRACE(GDGDEF(DSN(IMSTESTL.BPETOM) UNIT(SYSDA) VOLSER(000000)
SPACE(5) ) COMP(OM) ) /* <----- EXTTRACE for OM */

EXTTRACE(GDGDEF(DSN(IMSTESTL.BPETODBM) UNIT(SYSDA) VOLSER(000000)
SPACE(5) ) COMP(ODBM) ) /* <----- EXTTRACE for ODBM */

```

Sample BPE configuration using symbolic parameters for EXTTRACE statements

A sample BPE member of the IMS PROCLIB data set with EXTTRACE statements using symbolic parameters is shown in the example below.

```

#
# DEFINITIONS FOR SYSTEM TRACES
#
TRCLEV=(*,LOW,BPE,EXTERNAL=NO)

# SCI:

TRCLEV=(ERR,HIGH,SCI,EXTERNAL=NO)
TRCLEV=(INTF,LOW,SCI,EXTERNAL=YES)
TRCLEV=(INTP,HIGH,SCI,EXTERNAL=YES)
TRCLEV=(SCI,MEDIUM,SCI,EXTERNAL=YES)

#OM:

TRCLEV=(*,LOW,OM,EXTERNAL=YES)

#ODBM:

TRCLEV=(*,LOW,ODBM,EXTERNAL=YES)

#DBRC:

TRCLEV=(*,MEDIUM,DBRC,EXTERNAL=YES)

#RM:

TRCLEV=(CSL,HIGH,RM,EXTERNAL=YES)
TRCLEV=(ERR,HIGH,RM,EXTERNAL=NO)
TRCLEV=(PLEX,LOW,RM,EXTERNAL=YES)
TRCLEV=(RM,MEDIUM,RM,EXTERNAL=YES)

```

```
# External trace definitions:
# Use symbolic symbols in the DSN, SMS testing
/* EXTTRACE with symbolic data set name BPE&JOBNAME */
EXTTRACE(GDGEF(DSN(IMSTESTL.BPE&JOBNAME) STORCLAS(SNPSTOR)
SPACE(20) AVGREC(K) DATACLAS(SNPDATA) ) )

/* EXTTRACE statement specifically for RM address space */
/* to allow it to have a name and characteristics */
/* different from the generic specification, above. */
EXTTRACE(GDGDEF(DSN(IMSTESTL.RMTRACE) STORCLAS(SNPSTOR)
SPACE(30) AVGREC(K) DATACLAS(SNPDATA)) COMP(RM) )
```

Related concepts

[“Overview of the IMSRSC repository” on page 37](#)

A repository is a generalized data storage facility that can be used to store any type of information. The IMS resource definition (IMSRSC) repository is a set of VSAM key sequenced data sets (KSDSs) used for storing information. The IMSRSC repository is a repository to store resource (and descriptor) definitions for IMS databases, transactions, programs, and routing codes. This repository is an alternative to the resource definition data set (RDDS) that is used with the dynamic resource definition (DRD) function.

Related tasks

[“Defining the IMSRSC repository” on page 40](#)

Before you can use the IMSRSC repository to store and retrieve resource and descriptor definitions, you must define it. In addition, IMS and the Resource Manager (RM) must have the repository enabled, the Repository Server (RS) must be started and active, and the repository must be started.

[“Setting up tracing for BPE-managed address spaces” on page 345](#)

The member of the IMS PROCLIB data set that you specify using the BPECFG= parameter in the execution parameters for the BPE-managed address spaces defines configuration parameters to the Base Primitive Environment (BPE), including trace levels.

Related reference

[Base Primitive Environment commands \(Commands\)](#)

[BPE UPDATE TRACETABLE command \(Commands\)](#)

[RM trace record example \(Diagnosis\)](#)

[“FRPCFG member of the IMS PROCLIB data set” on page 911](#)

Use the FRPCFG member of the IMS PROCLIB data set to define the Repository Server (RS) configuration parameters relating to performance, communications, and security. FRPCFG also identifies the names of the RS catalog repository data sets.

[“CSLRxxxx member of the IMS PROCLIB data set” on page 719](#)

Use the CSLRxxxx member of the IMS PROCLIB data set to specify parameters that initialize RM.

[“Trace environment - conservative” on page 341](#)

You can specify the CQS execution parameter BPECFG=*nnnnnnnn* in a way that is optimal for conservative trace environments.

[“Trace environment - more aggressive” on page 341](#)

You can specify the CQS execution parameter BPECFG=*nnnnnnnn* in a way that is optimal for more aggressive trace environments.

BPE exit list members of the IMS PROCLIB data set

Use the members of the IMS PROCLIB data set specified by the EXITMBR= parameter in the BPE configuration parameter member of the IMS PROCLIB data set to define user exit routines to BPE.

BPE exit list members of the IMS PROCLIB data set are IMS-component specific. In the BPE configuration parameter member of the IMS PROCLIB data set, specify one EXITMBR statement for each IMS component that provides user exit routines through BPE services. Each EXITMBR statement specifies the name of an IMS PROCLIB data set member that contains the definitions for exit routines for that IMS component. You can have a separate exit list member for each IMS component, or you can share one exit list member among several IMS components.

A BPE exit list member associates a user exit routine type with a list of one or more user exit routines. Use the EXITDEF statement to define the exit routine modules to be called for a particular exit routine type. The BPE exit list member is processed by BPE during address space initialization. It is also processed when you enter a REFRESH USEREXIT command (see *IMS Version 15.4 Commands, Volume 2: IMS Commands N-V* for more information about BPE USEREXIT commands).

Environments

The BPE exit list member of the IMS PROCLIB data set can be used whenever you are using an IMS address space that uses BPE, such as CQS, DBRC, ODBM, OM, RM, SCI, and IMS Connect.

BPE EXITMBR= EXITDEF syntax

You can use the IMS Syntax Checker to modify this member of the IMS PROCLIB data set.

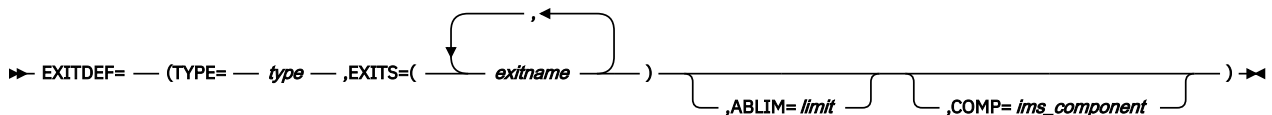

Usage

The EXITDEF statement associates an exit routine type with a list of one or more exit routine modules to be called. The modules are called in the order listed. The EXITDEF statement consists of a sublist (enclosed in parentheses) containing the keywords TYPE, EXITS, ABLIM, and COMP.

Recommendation: Avoid coding statements in the BPE exit routine list member that specify definitions for the same exit routine type multiple times. BPE always uses the last statement it encounters in the member for a particular exit routine. Any earlier statements for the same exit routine are ignored. Message BPE0017I is issued for each duplicate statement found.

If you code the same user exit routine name more than once in the exit routine list (EXIT=) of any single EXITDEF= statement, BPE always uses the first occurrence of the exit routine module name to determine the order for calling the exit routines. Duplicate names are ignored, and a message, BPE0018I is issued for each duplicate name.

BPE EXITMBR= EXITDEF parameters

TYPE=type

Specifies the type of exit routine. The IMS component defined on COMP= determines the types of exit routines that are supported. Refer to *IMS Version 15.4 Exit Routines* for more information about these types of exit routines.

BPE exit routine types

All BPE-owned user exit routines are available to all IMS address spaces running with BPE.

INITTERM

An exit routine that is called once during early BPE initialization, and once during normal termination.

STATS

An exit routine that is called periodically (it is timer-driven), and is called once during normal address space shut down, with statistics about BPE system functions. Optionally, the IMS component that is running on BPE can provide statistics specific to its operation.

CQS exit routine types

CLNTCONN

An exit routine that is called during client connect and disconnect processing.

INITTERM

An exit routine that is called during various phases of initialization and termination.

OVERFLOW

An exit routine that is called during overflow threshold processing to select queue names for overflow processing.

STRSTAT

An exit routine that is called during checkpoint processing to allow you to gather structure statistics.

STREVENT

An exit routine that is called for various structure events. For certain structure events, it also allows you to gather structure statistics like the STRSTAT exit routine.

DBRC exit routine types**RECONIO**

An exit routine that is called to allow for auditing of DBRC RECON data set I/O. If this exit routine is specified, the standard RECON I/O exit routine, DSPCEXT0, is not called.

REQUEST

An exit routine that is called at start and end of DBRC request processing.

SECURITY

An exit routine that is called to allow user security checking before command execution. If this exit routine is specified, the standard DBRC command authorization exit routine, DSPDCAX0, is called.

IMS Connect exit routine types**ODBMAUTH**

IMS Connect DB security user exit, which enables users to access IMS database resources via ODBA from outside an IMS dependent region.

ODBMROUT

IMS Connect Routing exit for ODBM, which enables users to override the IMS alias or to select an ODBM.

PORnnnnn

IMS Connect Port Message Edit exit. *nnnnn* in the exit type name is the port number in decimal— for example, POR01234. The Port Message Edit exit is a BPE type-2 exit.

XMLADAP

An exit routine that is called to perform XML-to-COBOL data conversion in IMS Connect.

ODBM exit routine types**CLNTCONN**

An exit routine that is called during client command registration and deregistration processing.

INITTERM

An exit routine that is called during various phases of initialization and termination.

INPUT

An exit routine that is called to view DL/I calls that are issued to IMS databases. This exit routine can either modify the command before execution or reject the command before it is processed.

OUTPUT

An exit routine that is called to view output (for example, ODBA call output) from ODBM to an ODBM client. The exit routine can modify the output before it is returned to the originator of the command.

OM exit routine types**CLNTCONN**

An exit routine that is called during client command registration and deregistration processing.

INITTERM

An exit routine that is called during various phases of initialization and termination.

INPUT

An exit routine that is called to view command input to the Operations Manager. This exit routine can either modify the command before execution or reject the command before it is processed.

OUTPUT

An exit routine that is called to view output (for example, command response) from Operations Manager to an automation client. The exit routine can modify the output before it is returned to the originator of the command.

SECURITY

An exit routine that is called to allow user security checking before command execution.

RM exit routine types**CLNTCONN**

An exit routine that is called during client connect and disconnect processing.

INITTERM

An exit routine that is called during various phases of initialization and termination.

SCI exit routine types**CLNTCONN**

An exit routine that is called during client connect and disconnect processing.

INITTERM

An exit routine that is called during various phases of initialization and termination.

EXITS=(*exitname*,...)

Specifies a list of one or more exit routine module names. The position of the exit routine in the list determines the order in which the exit routine is driven. The default order is first to last (the first exit listed on the EXITS= parameter is the first exit to be called). However, for some exit types, the order is reversed (the last exit listed is the first to be called). Exit types that use a reverse call order explicitly state this in their documentation. Refer to *IMS Version 15.4 Exit Routines* for the specific exit type you are writing to determine the exit call order.

When an exit routine returns to its caller, it indicates whether additional exit routines are to be called.

ABLIM=*limit*

A number from 0 to 2 147 483 647 that specifies the abend limit for the type of exit routine being defined. If the number of abends for an exit routine module reaches the abend limit for the exit routine type, the module is removed from the exit routine list and is not called until the exit routine type is refreshed.

This parameter is optional; the default is 1. If you specify a value of 0, there is no abend limit.

COMP=*ims_component*

An optional parameter that specifies the type of the IMS component that owns the exit routine being defined. Possible values are:

BPE

Base Primitive Environment

CQS

Common Queue Server

DBRC

Database Recovery Control

HWS

IMS Connect

ODBM

Open Database Manager

OM

Operations Manager

RM

Resource Manager

SCI

Structured Call Interface

BPE processes only EXITDEF statements that:

- Do not have COMP coded
- Have COMP=*ims_component* coded (where *ims_component* matches the IMS component specified on the EXITMBR statement that points to the BPE user exit PROCLIB member currently being processed).

For example, if BPE were processing the BPEEXIT0 PROCLIB member specified on the EXITMBR=(BPEEXIT0,BPE) statement, it would only process EXITDEF statements that had no COMP= specified, and those that had COMP=BPE specified. If BPE were processing the CQSEXIT0 PROCLIB member specified on the EXITMBR=(CQSEXIT0,CQS) statement, it would only process EXITDEF statements that had no COMP= specified, and those that had COMP=CQS specified.

For any given IMS component address space, BPE only processes BPE user exit PROCLIB members for EXITMBR statements that specify BPE, and those that specify the IMS component name of the address space that is running (for example, CQS, DBRC, HWS, ODBM, OM, RM, or SCI).

Examples

Several sample user exit list members of the IMS PROCLIB data set are provided.

Sample BPE user exit list member of the IMS PROCLIB data set

The sample BPE user exit list member of the IMS PROCLIB data set shown below defines:

- One BPE init/term exit routine
- One BPE Statistics exit routine

```
*****
* BPE USER EXIT LIST PROCLIB MEMBER
*****
#-----#
# Define one BPE init/term exit: MYINIT00.
#-----#
EXITDEF(TYPE=INITTERM,EXITS=(MYINIT00))

#-----#
# Define 1 BPE Statistics exit: HHGSTAT0 with an abend limit of 42#
#-----#
EXITDEF(TYPE=STATS,EXITS=(HHGSTAT0),ABLIM=42)

#-----#
# Define 1 statistics exit for DBRC statistics : STATS01
#-----#
EXITDEF(TYPE=STATS,EXITS=(STATS01),COMP=BPE)
```

Sample CQS user exit list member of the IMS PROCLIB data set

The sample CQS user exit list member of the IMS PROCLIB data set shown below defines:

- One client connection exit routine
- Two INITTERM user exit routines
- Four overflow exit routines
- One structure statistic exit routine
- One CQS structure event user exit routine

```
*****
* CQS USER EXIT LIST PROCLIB MEMBER
*****
#-----#
# DEFINE 1 CLIENT CONNECTION EXIT: CLCONX00
#-----#
EXITDEF(TYPE=CLNTCONN,EXITS=(CLCONX00))
```



```

#-----#
# DEFINE 2 INITTERM USER EXITS: MYCQSIT0 AND OEMCQIT0 #
# WITH AN ABEND LIMIT OF 8. #
#-----#
EXITDEF (TYPE=INITTERM,EXITS=(MYCQSIT0,OEMCQIT0),ABLIM=8)

#-----#
# DEFINE 4 OVERFLOW EXITS: OVERFL01, OVERFL02, OVERFL03, OVERFL04 #
#-----#
EXITDEF (TYPE=OVERFLOW,EXITS=(OVERFL01,
                              OVERFL02,
                              OVERFL03,
                              OVERFL04))

#-----#
# DEFINE 1 STRUCTURE STATISTIC EXIT: STRSTAT0 #
#-----#
EXITDEF (TYPE=STRSTAT,EXITS=(STRSTAT0))

#-----#
# DEFINE 1 CQS STRUCTURE EVENT USER EXIT (STREVT0) WITH #
# NO ABEND LIMIT #
#-----#
EXITDEF (TYPE=STREVENT,EXITS=(STREVT0),ABLIM=0)

```

Sample DBRC user exit list member of the IMS PROCLIB data set

The sample DBRC user exit list member of the IMS PROCLIB data set shown below defines:

- One RECON I/O exit routine
- An abend limit of 8.
- Three DBRC security exit routines

```

/*****/
/* DBRC USER EXIT LIST PROCLIB MEMBER *
/*****/
#-----#
# Define 1 DBRC RECON I/O exit: RECONIO1 #
#-----#
EXITDEF (TYPE=RECONIO,EXITS=(RECONIO1),ABLIM=8,COMP=DBRC)

#-----#
# Define 3 DBRC security exits: SECUIRE01, SECURE02, and SECURE03 #
#-----#
EXITDEF (TYPE=SECURITY,EXITS=(SECURE03,SECURE01,SECURE02),COMP=DBRC)

```

Sample ODBM user exit list member of the IMS PROCLIB data set

The sample DBRC user exit list member of the IMS PROCLIB data set shown below defines:

- One ODBM initialization/termination exit routine
- An abend limit of 8.
- One ODBM output exit routine

```

*****
* ODBM USER EXIT LIST PROCLIB MEMBER *
*****
#-----#
# DEFINE 1 ODBM INIT/TERM USER EXIT: ZDINTM00 #
#-----#
EXITDEF (TYPE=INITTERM,EXITS=(ZDINTM00),COMP=ODBM)

#-----#
# DEFINE 1 ODBM INPUT USER EXIT: ZINPUT00 #
# WITH AN ABEND LIMIT OF 8. #
#-----#
EXITDEF (TYPE=INPUT,EXITS=(ZINPUT00),ABLIM=8,COMP=ODBM)

#-----#
# DEFINE 1 ODBM OUTPUT USER EXIT: ZOUTPUT0 #
#-----#
EXITDEF (TYPE=OUTPUT,EXITS=(ZOUTPUT0),COMP=ODBM)

```

Sample IMS Connect user exit list member of the IMS PROCLIB data set

The sample IMS Connect user exit list member of the IMS PROCLIB data set shown below defines the XML adapter system routine.

```
*****
* HWS USER EXIT LIST PROCLIB MEMBER *
*****

#-----#
# Define XML Adapter system routine: HWSXMLA0 #
#-----#
EXITDEF (TYPE=XMLADAP ,EXITS=(HWSXMLA0) ,ABLIM=8 ,COMP=HWS)
```

Sample OM user exit list member of the IMS PROCLIB data set

The sample OM user exit list member of the IMS PROCLIB data set shown below defines:

- One OM init/term exit routine
- Two OM client connection exit routines
- One OM command input exit routine
- One OM command output exit routine
- Three OM security exit routines

```
*****
* OM USER EXIT LIST PROCLIB MEMBER *
*****

#-----#
# Define one OM init/term exit: OMINITRM. #
#-----#
EXITDEF (TYPE=INITTERM,EXITS=(OMINITRM))

#-----#
# Define 2 OM client connection exits: OMCLCN00 and OEMCLI00 #
# with an abend limit of 2. #
#-----#
EXITDEF (TYPE=CLNTCONN,EXITS=(OMCLCN00,OEMCLI00) ,ABLIM=2)

#-----#
# Define one OM command input exit: MYCMI000 #
# with no abend limit. #
#-----#
EXITDEF (TYPE=INPUT,EXITS=(MYCMI000) ,ABLIM=0)

#-----#
# Define one OM command output exit: MYCMO000 #
# with no abend limit. #
#-----#
EXITDEF (TYPE=OUTPUT,EXITS=(MYCMO000) ,ABLIM=0)

#-----#
# Define 3 OM security exits: OMSEC000,OMSEC001, and ZZZSEC00 #
#-----#
EXITDEF (TYPE=SECURITY,EXITS=(OMSEC000,
                             OMSEC001,
                             ZZZSEC00))
```

Sample RM user exit list member of the IMS PROCLIB data set

The sample RM user exit list member of the IMS PROCLIB data set shown below defines:

- One RM init/term exit routine
- Two RM client connection exit routines

```
*****
* RM USER EXIT LIST PROCLIB MEMBER *
*****

#-----#
# Define one RM init/term exit: RMINITRM. #
#-----#
EXITDEF (TYPE=INITTERM,EXITS=(RMINITRM))
```

```

#-----#
# Define 2 RM client connection exits: RMCLCN00 and XYZCLCN0 #
# with an abend limit of 6. #
#-----#
EXITDEF (TYPE=CLNTCONN,EXITS=(RMCLCN00,XYZCLCN0),ABLIM=6)

```

Sample SCI user exit list member of the IMS PROCLIB data set

The sample SCI user exit list member of the IMS PROCLIB data set is shown below defines:

- One SCI init/term exit routine
- Three SCI client connection exit routines

```

*****
* SCI USER EXIT LIST PROCLIB MEMBER *
*****
#-----#
# Define one SCI init/term exit: SCINITRM. #
#-----#
EXITDEF (TYPE=INITTERM,EXITS=(SCINITRM))

#-----#
# Define 3 SCI client connection exits: SCCLCN00, SCCLCN10, #
# and SCCLCN20 with an abend limit of 9. #
#-----#
EXITDEF (TYPE=CLNTCONN,EXITS=(SCCLCN00,SCCLCN10,SCCLCN20),ABLIM=9)

```

Sample combined user exit list member of the IMS PROCLIB data set

You can combine all the preceding user exit list members into a single shared member by using the COMP keyword on the EXITDEF statements, as shown below. The sample defines:

- BPE exit routines
- CQS user exit routines
- DBRC user exit routines
- IMS Connect user exit routines
- OM user exit routines
- RM user exit routines
- SCI user exit routines

```

*****
* BPE EXIT DEFINITIONS *
*****
EXITDEF=(TYPE=INITTERM,EXITS=(MYINIT00),COMP=BPE)
EXITDEF=(TYPE=STATS,EXITS=(HHGSTAT0),ABLIM=42,COMP=BPE)
*****
* CQS USER EXIT ROUTINE DEFINITIONS *
*****
EXITDEF=(TYPE=CLNTCONN,EXITS=(CLCONX00),COMP=CQS)
EXITDEF=(TYPE=INITTERM,EXITS=(MYCQSIT0,OEMCQIT0),ABLIM=8,COMP=CQS)
EXITDEF=(TYPE=OVERFLOW,EXITS=(OVERFL01,
                                OVERFL02,
                                OVERFL03,
                                OVERFL04),COMP=CQS)
EXITDEF=(TYPE=STRSTAT,EXITS=(STRSTAT0),COMP=CQS)
EXITDEF=(TYPE=STREVENT,EXITS=(STREVENT),ABLIM=0,COMP=CQS)

/*****
/* DBRC USER EXIT LIST PROCLIB MEMBER */
/*****
#-----#
# DEFINE 1 RECON I/O EXIT: ZDBRCIO0 #
# WITH AN ABEND LIMIT OF 8. #
#-----#
EXITDEF (TYPE=RECONIO,EXITS=(ZDBRCIO0),ABLIM=8,COMP=DBRC)
#-----#
# DEFINE 1 DBRC SECURITY EXIT: ZDBRCSE0 #
#-----#
EXITDEF (TYPE=SECURITY,EXITS=(ZDBRCSE0),COMP=DBRC)
*****

```

```

* HWS USER EXIT LIST PROCLIB MEMBER *
*****
EXITDEF (TYPE=XMLADAP , EXITS=(HWSXMLA0) , ABLIM=8 , COMP=HWS)

*****
* OM USER EXIT ROUTINE DEFINITIONS *
*****
EXITDEF=(TYPE=INITTERM, EXITS=(OMINITRM) , COMP=OM)
EXITDEF=(TYPE=CLNTCONN, EXITS=(OMCLCN00, OEMCLI00) , ABLIM=2, COMP=OM)
EXITDEF=(TYPE=INPUT, EXITS=(MYCMI000) , ABLIM=0, COMP=OM)
EXITDEF=(TYPE=OUTPUT, EXITS=(MYCMO000) , ABLIM=0, COMP=OM)
EXITDEF=(TYPE=SECURITY, EXITS=(OMSEC000,
                               OMSEC001,
                               ZZZSEC00) , COMP=OM)

*****
* RM USER EXIT ROUTINE DEFINITIONS *
*****
EXITDEF=(TYPE=INITTERM, EXITS=(RMINITRM) , COMP=RM)
EXITDEF=(TYPE=CLNTCONN, EXITS=(RMCLCN00, XYZCLCN0) , ABLIM=6, COMP=RM)

*****
* SCI USER EXIT ROUTINE DEFINITIONS *
*****
EXITDEF=(TYPE=INITTERM, EXITS=(SCINITRM) , COMP=SCI)
EXITDEF=(TYPE=CLNTCONN, EXITS=(SCCLCN00, SCCLCN10, SCCLCN20) , ABLIM=9,
        COMP=SCI)

```

Note: If you use a single shared user exit list member of the IMS PROCLIB data set, change the EXITMBR statements in the BPE configuration member of the IMS PROCLIB data set to point to the shared user exit list member. Here is an example of how you can change the EXITMBR statements:

```

#
# User exit list PROCLIB member specifications
#
EXITMBR=(SHREXIT0, BPE)           /* BPE user exit definitions */
EXITMBR=(SHREXIT0, CQS)          /* CQS user exit definitions */
EXITMBR=(SHREXIT0, OM)           /* OM user exit definitions */
EXITMBR=(SHREXIT0, RM)           /* RM user exit definitions */
EXITMBR=(SHREXIT0, SCI)          /* SCI user exit definitions */

```

Related concepts

“IMS Syntax Checker” on page 381

The Syntax Checker is an ISPF application that helps you define, verify, and validate parameters and their values in the members of the IMS PROCLIB data set. Use the IMS Syntax Checker to avoid typographical and syntactical errors when modifying the parameter values for the IMS PROCLIB data set members.

CQSIPxxx member of the IMS PROCLIB data set

Use the CQSIPxxx member of the IMS PROCLIB data set to specify parameters that are related to initialization of the CQS address space. You can use CQS execution parameters to override certain parameters within CQSIPxxx.

Syntax

You can use the IMS Syntax Checker to modify this member of the IMS PROCLIB data set.

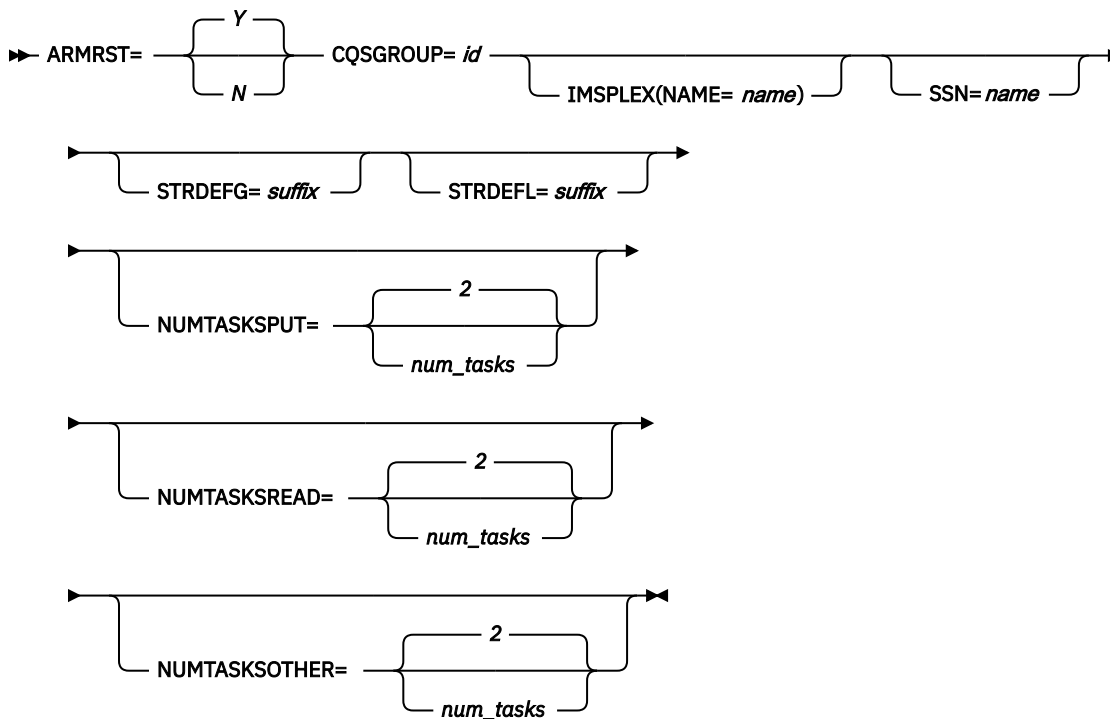

Usage

The following rules apply to the format of the CQSIPxxx member:

- The execution member consists of one or more fixed-length character records. (The configuration data set can be of any logical record length (LRECL) greater than eight, but it must be of fixed-record format.)
- The rightmost eight columns of each record are ignored and you can use them for sequence numbers or any other notation. In the remaining columns, you code the keyword parameters. For example, if your record size is 80, you use columns 1 through 72 for your configuration data. You can use columns 73 through 80 for sequence numbers.
- Keywords can contain leading and trailing blanks.
- Each record can contain multiple keywords.
- Use commas or spaces to delimit keywords.
- Use an asterisk (*) or pound sign (#) in column one to begin a comment. You can include a comment anywhere within a statement by enclosing it between a slash-asterisk and an asterisk-slash pair.

```
/*This is an example of a comment within a statement*/
```

- Values coded in this member of the IMS PROCLIB data set are case sensitive.

Parameters

ARMRST= Y | N

Specifies whether the z/OS Automatic Restart Manager (ARM) is used to restart the CQS address space after an abend. If you specify Y (yes), ARM restarts the CQS address space after most system failures. If you specify N (no), ARM does not restart the CQS address space after any system failure.

ARM does not restart the CQS address space if the CQS abends before restart is complete.

To restart the CQS when it has been canceled by z/OS, you must specify the ARMRESTART option of either the z/OS CANCEL or FORCE command.

Related reading: For information about the CANCEL and FORCE commands, see *MVS/ESA System Commands*.

This parameter can be specified as an execution parameter on the CQS procedure to override the value in CQSIPxxx.

CQSGROUP=

Specifies a 1- to 5-character identifier. CQS concatenates this identifier to the characters CQS to create the group name of the z/OS cross-system coupling facility CQS shared queues. You must use the same identifier for all CQS address spaces that share the same set of structures. You can also use the same identifier for the SQGROUP= parameter in the DFSSQxxx member of the IMS PROCLIB data set.

This parameter can be specified as an execution parameter on the CQS procedure to override the value in CQSIPxxx.

IMSPLEX()

Specifies the IMSplex to which CQS joins. IMSPLEX is an optional parameter. IMSPLEX does not have a default value. Only one IMSPLEX keyword can be specified. The IMSPLEX definition parameter follows:

NAME=

A 1- to 5-character user-specified identifier that is concatenated to 'CSL' to create the cross-system coupling facility (XCF) CSL IMSPLEX group name. The value specified here must match the IMSPLEX NAME= value specified in the SCI startup procedure. All OM, RM, SCI, IMS, CQS and similar address spaces must specify the same name to be part of the same IMSplex. The same identifier must also be used for the IMSPLEX= parameter in the CSLSIxxx, CSLOIxxx, CSLRIxxx, and DFSCGxxx members of the IMS PROCLIB data set.

NUMTASKSPUT=

Specifies the number of PUT request tasks (z/OS TCBs) per structure within the CQS address space. The number must be from 1 to 9. The default is 2.

PUT request tasks process CQSPUT and CQSUPD requests. The total number of PUT request tasks is equal to the NUMTASKSPUT value times the number of primary message queue and resource structures that are defined, but no more than 64.

Recommendation:

Use the default value for NUMTASKSPUT unless you are advised to use different values by IBM. It's a performance tuning parameter that relates to the number of tasks available within the CQS address space to process certain CQS requests.

The default value is generally sufficient.

Having more tasks can add capacity for certain peak high-volume situations, but can also possibly cause more contention and overhead.

NUMTASKSREAD=

Specifies the number of READ request tasks (z/OS TCBs, or SRBs if CONDSRB=COND or ALWAYS) per structure within the CQS address space. The number must be from 1 to 9. The default is 2.

READ request tasks process CQSREAD and CQSBRWSE requests. The total number of READ request tasks is equal to the NUMTASKSREAD value times the number of primary message queue and resource structures that are defined, but no more than 64.

Recommendation:

Use the default value for NUMTASKSREAD unless you are advised to use different values by IBM. It's a performance tuning parameter that relates to the number of tasks available within the CQS address space to process certain CQS requests.

The default value is generally sufficient.

Having more tasks can add capacity for certain peak high-volume situations, but can also possibly cause more contention and overhead.

NUMTASKSOTHER=

Specifies the number of OTHER request tasks (z/OS TCBS) per structure within the CQS address space. The number must be from 1 to 9. The default is 2.

OTHER request tasks process CQSDDEL, CQSINFRM, CQSMOVE, CQSRECV, CQSRSYNC, and CQSUNLCK requests. The total number of OTHER request tasks is equal to the NUMTASKSOTHER value times the number of primary message queue and resource structures that are defined, but no more than 64.

Recommendation:

Use the default value for NUMTASKSOTHER unless you are advised to use different values by IBM. It's a performance tuning parameter that relates to the number of tasks available within the CQS address space to process certain CQS requests.

The default value is generally sufficient.

Having more tasks can add capacity for certain peak high-volume situations, but can also possibly cause more contention and overhead.

SSN=

Specifies the name for the CQS address space. The value must be 1 - 4 alphanumeric characters. The SSN= parameter can be specified either in the CQSIPxxx PROCLIB member or as a CQS execution parameter. If the SSN= parameter is specified in both the CQSIPxxx PROCLIB member and as an execution parameter, the value specified for the execution parameter overrides the value specified in the CQSIPxxx PROCLIB member. The name specified is used to create the CQSID, which is used in CQS processing. The CQSID is the SSN followed by the characters CQS. Every CQS within the same CQSGROUP must have a unique name. Additionally, every CQS running on the same LPAR must have a unique name, regardless of what CQSGROUP it is in. Recommendation: Give unique names to all CQSS across your sysplex. This helps to avoid name conflicts if CQSS are ever moved among LPARs.

Every CQS within the same CQSGROUP must have a unique name. Additionally, every CQS running on the same LPAR must have a unique name, regardless of what CQSGROUP it is in.

Recommendation: Give unique names to all CQSS across your sysplex. This helps to avoid name conflicts if CQSS are ever moved among LPARs.

Example: If SSN=ABC, CQSID=ABCCQS.

Trailing blanks are deleted and the CQSID is padded with blanks.

Note: CQS does not register as a IBM z/OS subsystem.

STRDEFG=

Specifies a 3-character suffix for the CQS global structure definition member of the IMS PROCLIB data set, CQSSGxxx. This member contains the parameters related to the coupling facility structures that are common to all CQS address spaces that are sharing the queues. If you specify this as an execution parameter on the CQS startup procedure, it overrides the value specified in the CQSIPxxx member of the IMS PROCLIB data set. The default suffix is 000.

STRDEFL=

Specifies a 3-character suffix for the CQS local structure definition member of the IMS PROCLIB data set, CQSSLxxx. This member contains the parameters that are related to the coupling facility structures and that are unique to an individual CQS address space. If you specify this as an execution parameter on the CQS startup procedure, it overrides the value specified in the CQSIPxxx member of the IMS PROCLIB data set. The default suffix is 000.

Sample CQSIPxxx member of the IMS PROCLIB data set

A sample CQSIPxxx member of the IMS PROCLIB data set is shown here:

```
*****
* CQS INITIALIZATION PROCLIB MEMBER
*****
ARMRST=Y                /* ARM SHOULD RESTART CQS ON FAILURE */
```

```

CQSGROUP=GRUP1      /* GROUP NAME (XCF GROUP = GRUP1CQS)    */
SSN=CQS1           /* CQS ADDRESS SPACE (CQSID = CQS1CQS)   */
STRDEFG=190        /* GLOBAL STR DEFINITION MEMBER = CQSSG190 */
STRDEFL=191        /* LOCAL STR DEFINITION MEMBER = CQSSL191 */
IMSPLEX (NAME=PLEX1) /* IMSPLEX NAME (CSLPLEX1)              */

```

Related concepts

“IMS Syntax Checker” on page 381

The Syntax Checker is an ISPF application that helps you define, verify, and validate parameters and their values in the members of the IMS PROCLIB data set. Use the IMS Syntax Checker to avoid typographical and syntactical errors when modifying the parameter values for the IMS PROCLIB data set members.

Related tasks

“Preparing to start the CQS address space” on page 242

Before you can start the Common Queue Server (CQS) address space, you must define CQS parameters, and you must create and activate the necessary z/OS policies.

CQSSLxxx member of the IMS PROCLIB data set

Use the CQSSLxxx member of the IMS PROCLIB data set to define local CQS parameters that are related to one or more coupling facility structures.

Each CQS should point to a different CQSSLxxx member. CQS connects to each defined structure in the member. The structures defined in the CQSSLxxx member must also be defined in the CQSSGxxx member of the IMS PROCLIB data set.

Important: The CQSSLxxx member of the IMS PROCLIB data set applies to queue structures only, not resource structures. If you do not define queue structures, you do not need to define the CQSSLxxx member of the IMS PROCLIB data set.

Syntax

You can use the IMS Syntax Checker to modify this member of the IMS PROCLIB data set.

```

➔ STRUCTURE(STRNAME= name,CHKPTDSN= name
           ,SYSCHKPT= number
           ,BATCHDEL=YES
           ,BATCHDEL=NO
           ,STRCHKPT= number ) ➔

```

Restrictions

The CQSSLxxx member of the IMS PROCLIB data set applies to queue structures only, not resource structures. If you do not define queue structures, you do not need to define the CQSSLxxx member of the IMS PROCLIB data set.

Usage

The following rules apply to the format of the CQSSLxxx member:

- The execution member consists of one or more fixed-length character records. (The configuration data set can be of any LRECL greater than eight, but it must be of fixed-record format.)
- The rightmost eight columns of each record are ignored and can be used for sequence numbers or any other notation. In the remaining columns, you code the keyword parameters. For example, if your record size is 80, you use columns 1 through 72 for your configuration data. You can use columns 73 through 80 for sequence numbers.
- Keywords can contain leading and trailing blanks.
- Each record can contain multiple keywords.
- Commas or spaces delimit keywords.
- A comment begins with an asterisk (*) or pound sign (#) in column one. You can include a comment anywhere within a statement by enclosing it between a slash-asterisk and an asterisk-slash pair.

```

/*This is an example of a comment within a statement*/

```

- Values coded in this member of the IMS PROCLIB data set are case sensitive.

If the STRUCTURE statement for an EMHQ structure is deleted from the CQSSLxxx member of the IMS PROCLIB data set, resources for the EMHQ structure and its associated CQS data sets are not allocated.

Parameters

Use the following keyword parameters to define a structure to CQS.

STRUCTURE()

The statement with which you define the structure definition parameters for the CQS. The structure definition parameters must be enclosed within parentheses. The STRUCTURE keyword must precede the left parenthesis.

Example: STRUCTURE (STRNAME=*strname*, CHKPTDSN=*chkptdsn*, ...)

STRNAME=

The required 1- to 16-character name of the primary coupling facility structure to which CQS connects.

The installation must have defined the structure in the coupling facility resource management (CFRM) administrative policy. The structure name must follow the naming rules of the CFRM. If the name has fewer than 16 characters, CQS pads the name with blanks. The valid characters are A-Z, 0-9, and the following special characters:

\$ @ # _

Names must be uppercase and start with an alphabetic character.

Restriction: Avoid using names that IBM uses for its structures. Do not begin structure names with the letters A-I, or with the character string SYS. If you do name a structure beginning with the letters A-I or SYS, your name might conflict with an existing or future IBM-defined structure name.

CHKPTDSN=

The required 1- to 44-character data set name of the cataloged VSAM data set that is used for the checkpoint data set for the indicated structure. The data set is dynamically allocated by CQS during CQS initialization. Each structure defined in CQSSLxxx must have a unique CHKPTDSN.

SYSCHKPT=

Specifies the number of log records CQS writes between system checkpoints. This value can be from 200 to 2 147 483 647. Each CQS address space that is connected to a queue structure can specify a different system checkpoint log record count. This value is not shared between CQS address spaces.

This parameter has no default. If you do not specify a value, automatic system checkpoints are only taken during restart, normal shut down, and after a structure checkpoint.

BATCHDEL=YES|NO

YES

BATCHDEL=YES causes CQS to write CQS delete-by-lock-token log records in batches. This reduces the number of CQS log records written to the z/OS log stream. This can reduce both the CQS log volume and the time it takes to process CQSDEL calls. However, if there is a CQS structure failure, and if CQS also fails and is not able to write its final batch delete log record, there may be previously-deleted objects that are restored to the structure in locked status after the structure is rebuilt. For this situation, the status of any object that remains locked after CQS/client resync processing is in doubt. CQS will move these objects to the cold queue, where they must be manually examined and either unlocked or deleted.

The default is **BATCHDEL=YES**.

NO

BATCHDEL=NO requires CQS to write additional log records to the z/OS log stream. However, because a CQS delete log record is written for every locked object passed on a CQSDEL call,

the status of deleted objects is not in doubt when a structure is rebuilt. CQS will not restore any previously-deleted objects to the rebuilt structure.

The BATCHDEL behavior is specific to the CQS structure for which it is coded, and to the CQS address space associated with the CQSSLxxx PROCLIB member:

- You can have different values for BATCHDEL specified for different structures managed by the same CQS.
- You can have different values for BATCHDEL specified for different CQSS managing the same structure.

A locked object is an object that has been read from a CQS structure by CQSREAD. CQS places the object on an internal CQS "locked queue" so that no other CQS client can access it while the client that has read the object processes it.

When a locked object is deleted from a queue structure via a CQSDDEL request (CQSDDEL by lock token), CQS constructs data that represents the object being deleted. When **BATCHDEL=YES** is specified or defaulted to, CQS places this data about a deleted object into a buffer in memory. This buffer can hold information for up to 100 deleted objects. When the buffer fills, CQS writes the full buffer to the structure's z/OS log stream. CQS can also write a partially-filled buffer at other times, such as at CQS system checkpoint and CQS termination. When **BATCHDEL=NO** is specified, CQS writes a separate delete log record to the z/OS log stream for each locked object passed on a CQSDDEL call. No batching of delete records occurs.

STRCHKPT=

Specifies the number of log records that a CQS address space can write after a structure checkpoint before the next automatic structure checkpoint. When this number is reached, CQS automatically performs a structure checkpoint. Specify this value in the range of 1000 - 2147483647. This value is not shared among CQS address spaces. This parameter is optional. For different CQS address spaces that are connected to a queue structure, you can specify different **STRCHKPT** values. If you do not specify a value, automatic structure checkpoints are not performed by the CQS that is associated with the particular CQSSLxxx member, but you can still perform CQS structure checkpoints by using the **/CQCHKPT SHAREDQ** command or the CQSCHKPT FUNC=CHKPTSTR CQS client request.

Sample CQSSLxxx member of the IMS PROCLIB data set

The following is a sample CQSSLxxx member of the IMS PROCLIB data set.

```
*****
* LOCAL STRUCTURE DEFINITION PROCLIB MEMBER *
*****
*-----*
* DEFINITION FOR IMS MESSAGE QUEUE STRUCTURE *
*-----*
STRUCTURE (
  STRNAME=QMSGIMS01,  CHKPTDSN=CQSA.QMSG.IMS01.CHKPT,  SYSCHKPT=1000000,
  STRCHKPT=2000000)
*-----*
* DEFINITION FOR IMS EMH QUEUE STRUCTURE *
*-----*
STRUCTURE (
  STRNAME=QEMHIMS01,  CHKPTDSN=CQSA.QEMH.IMS01.CHKPT,  SYSCHKPT=1000000,
  STRCHKPT=2000000)
```

Related concepts

["IMS Syntax Checker" on page 381](#)

The Syntax Checker is an ISPF application that helps you define, verify, and validate parameters and their values in the members of the IMS PROCLIB data set. Use the IMS Syntax Checker to avoid typographical and syntactical errors when modifying the parameter values for the IMS PROCLIB data set members.

CQSSGxxx member of the IMS PROCLIB data set

Use the CQSSGxxx member of the IMS PROCLIB data set to define global CQS parameters that are related to one or more coupling facility structures. These parameters are shared by all CQS address spaces that share the structures.

A particular CQS can support queue structures, resource structures, or a combination of both queue structures and resource structures. Each CQS sharing a structure must point to a CQSSGxxx member containing identical structure definition parameters.

Syntax

You can use the IMS Syntax Checker to modify this member of the IMS PROCLIB data set.

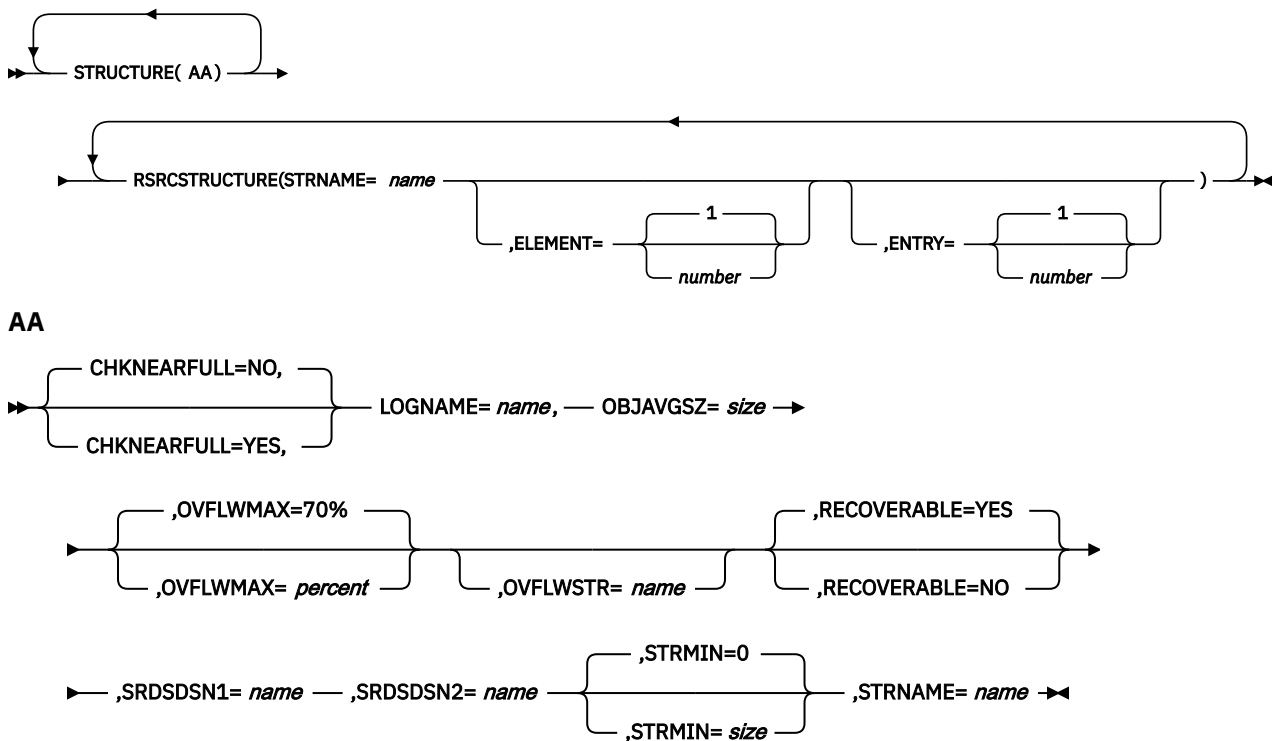

Usage

Point all CQSs to the same CQSSGxxx member to avoid parameter mismatches. CQS connects to each structure that is defined in the member. The structures defined in the CQSSGxxx member must also be defined in the CQSSLxxx member of the IMS PROCLIB data set.

If you are using queue structures, define an overflow structure name OVFLWSTR= if there is a possibility that you use an overflow structure. If you have to add an overflow structure later, the structure and all CQSs must be cold started.

If the STRUCTURE statement for an EMHQ structure is deleted from the CQSSGxxx member of the IMS PROCLIB data set, resources for the EMHQ structure are not allocated. These resources include the EMHQ structure's associated overflow structure, structure recovery data sets, and CQS log.

If you use RECOVERABLE=NO, consider that:

- RECOVERABLE=NO structures are truly not recoverable. If the structure fails, the data in it is lost. Before using RECOVERABLE=NO, carefully consider whether you can tolerate the loss of data in your

CQS shared queues structure if the structure or the coupling facility hardware fails. For example, a nonrecoverable queue might be acceptable for a test or development system; it might be unacceptable for a production system. Consider using a duplexed structure for a RECOVERABLE=NO structure in a production environment to provide redundancy.

- The failure of a nonrecoverable structure causes all CQSs that are connected to that structure to abend (ABENDU0373). If the structure was in overflow mode and the primary structure failed, the overflow structure is deleted. If the structure was in overflow and the overflow structure failed, the primary structure is cold started, and the overflow structure is not reallocated. All objects in the structures are lost. When the CQSs are restarted, they connect to an empty structure, resynchronize with their clients, and proceed with an empty queue. This processing is required to ensure that work that was in-flight when the structure failed is correctly resolved during the resynchronization at CQS restart.
- Changing between RECOVERABLE=NO and RECOVERABLE=YES requires a cold start of the CQS queue structure. You must delete the structure and the z/OS log stream, and scratch and reallocate the SRDS and system checkpoint data sets.
- Nonrecoverable structures require that SRDS data sets (SRSDSN1=, SRSDSN2=) be specified and allocated. Although the SRDS data sets are not used for recovery, client-initiated structure checkpoints (including the CQCHKPT macro, the /CQCHKPT IMS command, and CQS normal shut down checkpoints requested through the IMS /CQSET command) are still allowed. These checkpoints can be useful for diagnostics, as an alternative to taking a memory dump of the structure. Internally generated CQS structure checkpoints are skipped for nonrecoverable structures.
- RECOVERABLE=NO structures require that a z/OS log stream name be specified on the LOGNAME= parameter; however, the log stream does not have to be defined, and it is neither opened nor written to.
- When you start CQS with a RECOVERABLE=NO structure, message CQS0370I is issued, indicating that the structure is not recoverable.
- When you restart a CQS with a nonrecoverable structure, all restarts are cold starts (of the CQS, not the structure). When CQS connects to a structure that is not empty, message CQS0370I is issued, indicating that CQS is forcing a cold start for the structure.

The following rules apply to the format of the CQSSGxxx member:

- The execution member consists of one or more fixed-length character records. (The configuration data set can be of any LRECL greater than eight, but it must be of fixed-record format.)
- The rightmost eight columns of each record are ignored and can be used for sequence numbers or any other notation. In the remaining columns, you code the keyword parameters. For example, if your record size is 80, you use columns 1 through 72 for your configuration data. You can use columns 73 through 80 for sequence numbers.
- Keywords can contain leading and trailing blanks.
- Each record can contain multiple keywords.
- Commas or spaces delimit keywords.
- A comment begins with an asterisk (*) or pound sign (#) in column one. You can include a comment anywhere within a statement by enclosing it between a slash-asterisk and an asterisk-slash pair.

```
/*This is an example of a comment within a statement*/
```

- Values coded in this member of the IMS PROCLIB data set are case sensitive.

Parameters

Use the following parameters to define a structure to CQS. At least one STRUCTURE or RSRCSTRUCTURE definition is required.

STRUCTURE ()

Defines a queue structure to CQS. This keyword can be repeated. Keyword parameters must be enclosed within parentheses.

Example: STRUCTURE (STRNAME=*strname*, SRSDSN1=*srsdsn1*, ...)

The following keyword parameters are available to the STRUCTURE definition:

CHKNEARFULL

Optional parameter specifying whether (YES) or not (NO) CQS automatically takes a structure checkpoint when the log stream near-full conditions are detected. The default is NO.

The log stream near-full conditions happen in one of the following situations:

- Log stream usage reaches the 1/3 point between the high offload threshold percentage and 100% full (0.33% of the delta).
- Log stream usage reaches the 2/3 point between the high offload threshold percentage and 100% full (0.67% of the delta).

If you specify CHKNEARFULL=YES, CQS will take additional structure checkpoints when the z/OS log stream structure usage crosses the near-full thresholds. During the CQS message queue structure checkpoint process, CQS issues a log record delete request to the z/OS logger to relieve the log stream full condition. Using CHKNEARFULL=YES can help avoid log stream structure full situations; however, it might also result in additional CQS structure checkpoints.

If you specify CHKNEARFULL=NO, CQS will not take any additional structure checkpoints when log stream usage crosses the near-full thresholds. Specify CHKNEARFULL=NO or omit this parameter if you do not want CQS to take additional structure checkpoints when the z/OS log stream structure gets close to full.

LOGNAME=

Is the required 1- to 26-character name of the z/OS log stream that CQS uses to record all information related to the structure. The installation must have previously defined this name to the z/OS system logger.

All CQS address spaces that connect to a queue structure must use the same value for this parameter. The value specified by the CQS that initially allocates the structure is the value that is used for the life of the structure.

OBJAVGSZ=

Specifies the average size of a data object that is written to a queue on this structure. This value can range from 128 bytes to 61312 bytes or from 1K to 59K. The following list defines some IMS object sizes:

IMS client

The object size is the size of the IMS message plus some control information.

IMS queue manager messages

If the user message and the message queue prefix both fit completely into one queue buffer, the object size is the sum of the user message and the message queue prefix. If both parts do not fit into one queue buffer, the object size is the size of the portion of the message and the message queue prefix that do fit into one queue buffer. The size of an IMS message queue buffer is specified to the IMS control region by the QBUFSZ execution parameter.

IMS expedited message handler messages

The object size is the size of the user message plus 240 bytes (the size of the EMHB global header).

Each object in a CQS queue structure is stored using one entry and one or more 512-byte elements. The entry contains control data about the object on the queue. The elements contain the message data (IMS and CQS prefixes, and client data). The OBJAVGSZ parameter is used by CQS to determine the ratio of the number of entries to the number of elements within the coupling facility structure. OBJAVGSZ applies only to the initial allocation of the structure; it cannot be used to change the entry-to-element ratio of a structure that is already allocated.

For a structure defined with ALLOWAUTOALT(NO) in the CFRM policy, you must cold start the structure to change the entry-to-element ratio. This is because once CQS connects to a structure, it preserves the actual number of entries and elements obtained. If a structure rebuild occurs, CQS uses the actual entry-to-element ratio from these saved values when it connects to the rebuild structure, and not the values from OBJAVGSZ. This is done to ensure that the rebuild

structure has a similar number of entries and elements as the old structure, to reduce the chance of a rebuild failure.

For a structure defined with ALLOWAUTOALT(YES), you still must cold start the structure to change the entry-to-element ratio to a specific value (for example, to set the ratio to a value you have computed based on your message sizes). However, z/OS dynamically changes the entry-to-element ratio if it is not correct for the size of the objects in the structure.

Recommendation: Define your queue structures with the ALLOWAUTOALT(YES) parameter, to allow z/OS to dynamically adjust the entry-to-element ratio as necessary.

Recommendation: Specify the OBJAVGSZ to be the average of the sizes of all the objects passed to CQS by a CQSPUT request. CQS adds its own prefix containing control information to every object placed on the structure. CQS adds the length of its prefix to the OBJAVGSZ value that you specify to get the true average object size. Therefore, OBJAVGSZ should reflect only the average size of the objects as they are passed to CQS, not the average size of the object on the coupling facility.

If the OBJAVGSZ is too small, too much space in the structure is allocated for control information. The structure becomes full when all the space for data is used up, even though space for control information is still available.

If the OBJAVGSZ is too large, too much space in the structure is allocated for data. The structure becomes full when all the control space is used up, even though space for data is still available.

Example: Five objects are put on the structure by a CQSPUT request. The sizes of the objects are:

object 1

134 bytes

object 2

1066 bytes

object 3

3200 bytes

object 4

172 bytes

object 5

345 bytes

The average object size is calculated to be 983 bytes.

$$(134 + 1066 + 3200 + 172 + 345) / 5 = 983$$

OVFLWMAX=

Specifies the maximum threshold percentage for overflow processing. This value indicates the percentage of the structure that must be in use before CQS goes into overflow mode. This value can be from 50 to 100. For example, if OVFLWMAX=75, the structure is put into overflow mode when the structure usage reaches 75% of the structure size. The default is 70%.

The value specified by the CQS that initially allocates the structure is used for the life of the structure.

Recommendation: If your structure is defined with ALLOWAUTOALT(YES) in the CFRM policy, you should also code the FULLTHRESHOLD parameter in the policy, and specify a value that is at least five percent lower than the value specified on OVFLWMAX. This is to allow the z/OS auto alter function to adjust the entry-to-element ratio and the structure size before CQS enters overflow processing.

OVFLWSTR=

Is the 1- to 16-character name of the optional coupling facility structure to which CQS connects for structure overflow processing. The name must follow the same naming convention as the structure name specified by the STRNAME= parameter. When CQS is processing in overflow mode, selected queues are written to this structure instead of to the primary structure.

If an overflow structure is not specified and an overflow condition is detected, CQS rejects requests to add data objects to those queues that were selected for overflow.

If an overflow structure is specified, CQS connects to the overflow structure during CQS initialization and then again during phase one of overflow threshold processing. If CQS detects that the overflow structure size is less than 30% of the primary structure size, the overflow structure is considered to be too small and CQS issues the CQS0268W message. CQS is allowed to initialize even though the overflow structure is too small. CQS disconnects from and deletes the overflow structure at the end of CQS initialization.

CQS does not attempt to connect to the overflow structure again until the overflow threshold is reached. If at that time the overflow structure size is still less than 30% of the primary structure size, CQS again issues the CQS0268W message. CQS goes into overflow mode, but the overflow structure is not used. Requests to add data objects to those queues that were selected for overflow are rejected.

Recommendation: Define the size of the overflow structure in the CFRM policy to be at least X% of the primary structure size, where X is the value specified for the OVFLWMAX= parameter. The value specified for the OVFLWMAX= parameter indicates the percentage of the primary structure that must be in use before CQS goes into overflow mode, the overflow threshold. For example, if the overflow threshold was defined with the OVFLWMAX= parameter to be 75% of the primary structure size, the size of the overflow structure should be at least 75% of the primary structure size. If a value is not specified for the OVFLWMAX= parameter, the overflow threshold defaults to 70% and the size of the overflow structure should be at least 70% of the primary structure size.

An overflow structure name can be defined only when the structure is cold started. Once structures have been allocated, an overflow structure cannot be added unless the structure and all CQs are cold started.

All CQS address spaces that connect to a queue structure must use the same value for this parameter. The value specified by the CQS that initially allocates the structure is used for the life of the structure.

RECOVERABLE=

Optional parameter specifying whether (YES) or not (NO) the queue structure is recoverable. The default is YES.

By default, CQS queue structures are defined as recoverable. When data on a queue structure is changes, CQS records the change in a log record in the z/OS system log stream that is associated with the structure. Periodically, the contents of the queue structure are written to a structure recovery data set (SRDS). If a queue structure fails, CQS reallocates the structure and recovers it by first restoring the data from the last SRDS, and then applying any subsequent changes using the data from the z/OS log stream. This is the default for CQS queue structures (RECOVERABLE=YES).

You can optionally define a CQS queue structure as nonrecoverable (RECOVERABLE=NO). In this case, CQS does not write log records to a z/OS log stream. CQS does write structure checkpoint to an SRDS if one is requested; however, the checkpoints are not used for recovery. Using a nonrecoverable structure saves the overhead of using the z/OS logger. If the structure fails, however, all objects on the structure are lost.

SRDSDSN1=

Is a required 1- to 44-character data set name of the cataloged VSAM data set that is used for the first structure recovery data set. The data set name is used to dynamically allocate the data set when a structure checkpoint is requested. For a given structure checkpoint request, CQS uses either structure recovery data set 1 or data set 2. CQS alternates between the two data sets for structure checkpoint processing.

All CQS address spaces that connect to a queue structure must use the same value for this parameter. The value specified by the CQS that initially allocates the structure is the value that is used for the life of the structure.

SRDSDSN2=

Is a required 1- to 44-character data set name for the cataloged VSAM data set that is used for the second structure recovery data set. The data set name is used to dynamically allocate the data set when a structure checkpoint is requested. For a given structure checkpoint request, CQS uses either structure recovery data set 1 or data set 2. CQS alternates between the two data sets for structure checkpoint processing.

All CQS address spaces that connect to a queue structure must use the same value for this parameter. The value specified by the CQS that initially allocates the structure is the value that is used for the life of the structure.

STRMIN=

Specifies the value for the minimum primary structure size to which CQS can connect. This value is specified in units of 4 KB blocks and can be any value from 0 to the maximum structure size of 524288 (a 2-GB structure).

The default value is 0, indicating that CQS accepts the size as allocated by the coupling facility. If the coupling facility is constrained, the structure can be allocated to something smaller than that defined by the CFRM policy. Depending on the size, the structure might overflow sooner than expected.

Recommendation: Specify a value for STRMIN= that is less than the structure size that is defined in the policy.

The value specified by the CQS that initially allocates the structure is used for the life of the structure.

When the first CQS connects to an empty structure, that structure is allocated on the coupling facility. After it is allocated, the structure remains on the coupling facility regardless of whether a CQS is connected to it.

If, during connection to a structure, CQS determines that the size of the structure is smaller than the minimum size and the structure is empty, CQS terminates. In this case, the installation needs to redefine the use of the coupling facility to ensure that the required size can be allocated. If CQS connects to a structure that is smaller than the minimum size, but the structure contains data objects, CQS does not terminate. CQS attempts to use the smaller structure because it already contains data. In this case, CQS issues a message that allows an operator to initiate a structure rebuild in order to increase the structure size.

STRNAME=

The required 1- to 16-character name of the primary coupling facility structure to which CQS connects.

The installation must have defined the structure name in the CFRM administrative policy. The structure name must follow the naming rules of the CFRM. For names with fewer than 16 characters, CQS pads the name with blanks. The valid characters are A-Z, 0-9, and the following special characters:

\$ @ # _

Names must be uppercase and start with an alphabetic character.

Restriction: Avoid using names that IBM uses for its structures. Do not begin structure names with the letters A-I, or with the character string SYS. If you do name a structure beginning with the letters A-I or SYS, your name might conflict with an existing or future IBM-defined structure name.

RSRCSTRUCTURE ()

Defines a resource structure to CQS. An IMSplex can define only one resource structure; name uniqueness is within one resource structure. Keyword parameters must be enclosed within parentheses.

If you use shared queues, and you want IMS to manage serial programs across the IMSplex, you must define a resource structure. You must also identify the resource structure on the CSLRIxxx member of the IMS PROCLIB data set RSRCSTRUCTURE parameter.

Example: RSRCSTRUCTURE (STRNAME=*strname*)

The following keyword parameters are available:

STRNAME=

The required 1- to 16-character name of the coupling facility list structure to which CQS connects. This parameter defines the name of the resource structure used by RM to keep IMS resource information.

The installation must have defined the structure name in the CFRM administrative policy. The structure name must follow the naming rules of the CFRM. For names with fewer than 16 characters, CQS pads the name with blanks. The valid characters are A-Z, 0-9, and the characters \$, &, # and _. Names must be uppercase and start with an alphabetic character.

Restriction: Avoid using names IBM uses for its structures. Do not begin structure names with the letters A-I, or with the character string SYS.

ELEMENT=

Specifies the data element value of the entry-to-element ratio for resources that are used to allocate the resource structure. The number of data elements depends upon the resource type. To calculate the number of data elements needed, use the formulas in the topic "Calculating resource structure entry and element values". Valid values are from 1 to 65,535. The default is 1.

ENTRY=

Specifies the entry value of the entry-to-element ratio for resources that are used to allocate the resource structure. Each resource is stored on the resource structure using one entry and either zero, one, or more elements. The number of entries is equal to the number of resources. To calculate the number of entries needed, use the formulas in the topic "Calculating resource structure entry and element values". Valid values are from 1 to 65,535. The default is 1.

For a structure defined with ALLOWAUTOALT(NO) in the CFRM policy, you must cold start the structure to change the entry-to-element ratio. This is because once CQS connects to a structure, it preserves the actual number of entries and elements obtained. If a structure rebuild occurs, CQS uses the actual entry-to-element ratio from these saved values when it connects to the rebuild structure, and not the values from ELEMENT or ENTRY. This is done to ensure that the rebuild structure has a similar number of entries and elements as the old structure, to reduce the chance of a rebuild failure.

For a structure defined with ALLOWAUTOALT(YES), you still must cold start the structure to change the entry-to-element ratio to a specific value (for example, to set the ratio to a value you have computed based on your message sizes). However, z/OS dynamically changes the entry-to-element ratio if it is not correct for the size of the objects in the structure.

Recommendation: Define your resource structure with the ALLOWAUTOALT(YES) parameter, to allow z/OS to dynamically adjust the entry-to-element ratio as necessary.

Sample CQSSGxxx member of the IMS PROCLIB data set

A sample CQSSGxxx member of the IMS PROCLIB data set that defines both message queue and resource structures is shown here:

```
*****
* GLOBAL STRUCTURE DEFINITION PROCLIB MEMBER
*****
*-----*
* DEFINITION FOR IMS MESSAGE QUEUE STRUCTURES *
*-----*
STRUCTURE (
  STRNAME=QMSGIMS01,
  OVFLWSTR=QMSGIMS010FLW,
  SRDSDSN1=CQS.QMSG.IMS01.SRDS1
  SRDSDSN2=CQS.QMSG.IMS01.SRDS2,
  LOGNAME=SYSLOG.QMSG01.LOG,
  OBJAVGSZ=1024,
  CHKNEARFULL=YES)
```

```

*-----*
* DEFINITION FOR IMS EMH QUEUE STRUCTURES *
*-----*
STRUCTURE (
  STRNAME=QEMHIMS01,
  OVFLWSTR=QEMHIMS01OFLW,
  SRSDSN1=CQS.QEMH.IMS01.SRDS1,
  SRSDSN2=CQS.QEMH.IMS01.SRDS2,
  LOGNAME=SYSLOG.QEMH01.LOG,
  OBJAVGSZ=1024,
  CHKNEARFULL=YES)

*-----*
* DEFINITION FOR IMS RESOURCE STRUCTURE *
*-----*
RSRCSTRUCTURE (STRNAME=QRSCIMS01)

```

Related concepts

[Using structure alter for CQS \(System Administration\)](#)

[“IMS Syntax Checker” on page 381](#)

The Syntax Checker is an ISPF application that helps you define, verify, and validate parameters and their values in the members of the IMS PROCLIB data set. Use the IMS Syntax Checker to avoid typographical and syntactical errors when modifying the parameter values for the IMS PROCLIB data set members.

CSLDCxxx member of the IMS PROCLIB data set

Use the Open Database Manager (ODBM) configuration member of the IMS PROCLIB data set (CSLDCxxx) to define the data store connections between one or more ODBM instances and one or more IMS systems.

Each IMS system that ODBM can connect to is defined as a *data store* in the CSLDCxxx member of the IMS PROCLIB data set. Each data store has one or more alias names and several modifiable connection attributes.

Each instance of ODBM in an IMSplex can use a separate, local CSLDCxxx member of the IMS PROCLIB data set, or all the instances of ODBM in an IMSplex can share one CSLDCxxx member. The shared CSLDCxxx member of the IMS PROCLIB data set must be stored in a data set on shared DASD and concatenated to the local PROCLIB data set member of each ODBM instance that is sharing it. Sharing the CSLDCxxx member simplifies the management of data store connections across multiple instances of ODBM.

Open Database Manager (ODBM) can only connect to the IMS systems that are of the same version as ODBM itself. In a mixed-version IMSplex, to limit ODBM connection to the IMS systems of the same version, list the eligible IMS systems as data stores in the CSLDCxxx member of the IMS PROCLIB data set.

The parameters in the CSLDCxxx member of the IMS PROCLIB data set are organized into sections: a global section and a local section. The parameters in the global section of CSLDCxxx apply to all the data stores defined in the CSLDCxxx member of the IMS PROCLIB data set. The parameters in the local section of the CSLDCxxx member of the IMS PROCLIB data set apply only to specific data store connections of specific instances of ODBM. The parameters in the local section override the same parameters specified in the global section.

Both the global and local sections of the CSLDCxxx member of the IMS PROCLIB data set are identified by a predefined section header. These section headers are required in the CSLDCxxx member of the IMS PROCLIB data set even if no parameters are specified in the global section, as might be the case if all the default values are used.

The section header for the global section is: <SECTION=GLOBAL_DATASTORE_CONFIGURATION>. The section header for the local section is: <SECTION=LOCAL_DATASTORE_CONFIGURATION>.

The global data store configuration section defines attributes that are used by all the data store connections defined on this CSLDCxxx member of the IMS PROCLIB data set. You can specify the following attributes globally:

- IDRETRY: the number of times ODBM tries to connect to an IMS data store if the first attempt is unsuccessful

- **TIMER:** the amount of time to wait between connection attempts
- **MAXTHRDS:** the number of concurrent active threads that an IMS data store can have
- **MINTHRDS:** the minimum number of concurrent active threads that an IMS data store can have
- **FPBUF:** the number of Fast Path DEDB buffers to allocate and fix per thread
- **FPBOF:** the number of Fast Path DEDB overflow buffers to allocate per thread
- **CNBA:** the total number of Fast Path normal buffer allocation (NBA) buffers that an instance of ODBM can use for all its data store connections
- **SOD:** the system output class of a SNAP dump that is produced by the ODBM address space.
- **DIAGDPSBMSG:** Specifies the value of the `DIAGDPSBMSG=` parameter value to control the issuing of `CSL4202W` and `CSL4203W` messages in ODBM after an internal DPSB request from ICON is processed.

The local data store configuration section defines attributes for specific data store connections of specific instances of ODBM and overrides the same values specified in the global section:

- **ALIAS(NAME=):** the IMS alias names
- **MAXTHRDS:** the number of concurrent active threads that an IMS data store can have
- **MINTHRDS:** the minimum number of concurrent active threads that an IMS data store can have
- **FPBUF:** the number of Fast Path DEDB buffers to allocate and fix per thread
- **FPBOF:** the number of Fast Path DEDB overflow buffers to allocate per thread
- **CNBA:** the total number of Fast Path NBA buffers that an instance of ODBM can use for all its data store connections
- **SOD:** the system output class of a SNAP dump that is produced by the ODBM address space.

An example of the `CSLDCxxx` member of the IMS PROCLIB data set, is shown in [“Examples” on page 711](#).

You can use the IMS Syntax Checker to modify this member of the IMS PROCLIB data set.

Syntax

The following diagram shows the syntax for the parameters specified in the `CSLDCxxx` member of the IMS PROCLIB data set.

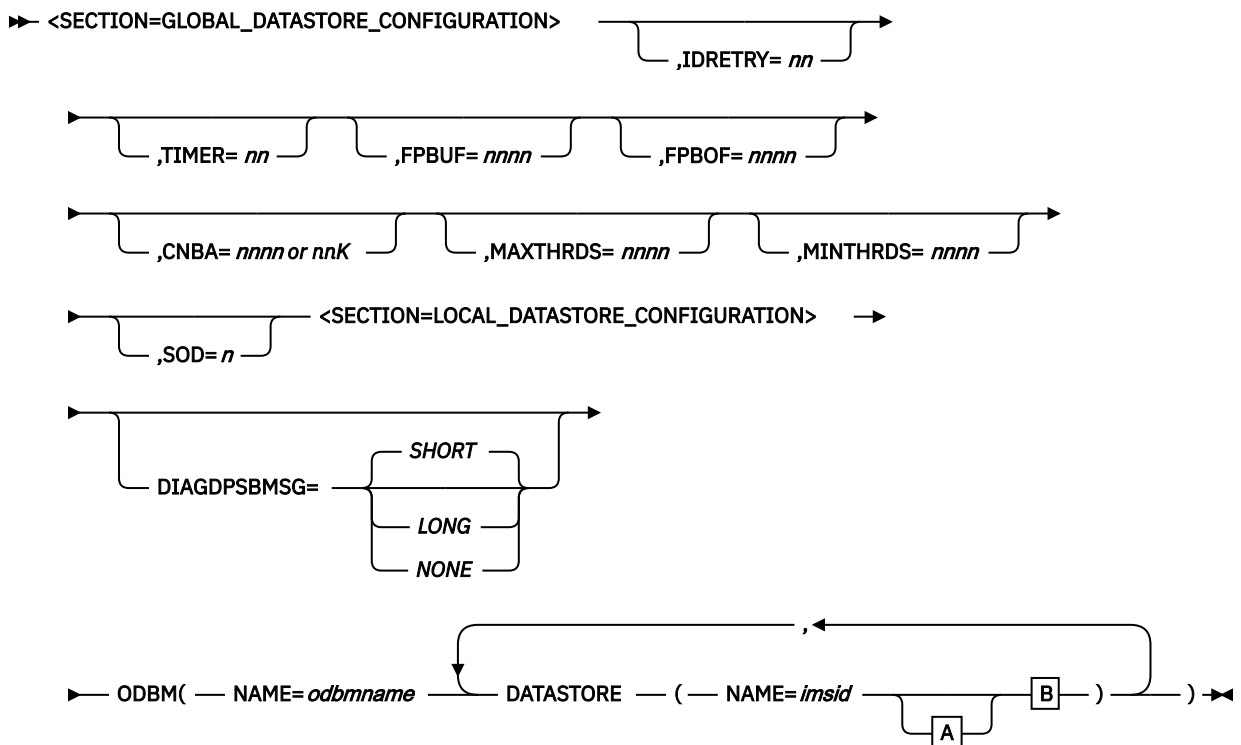

A

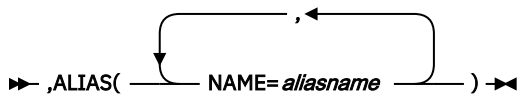

B

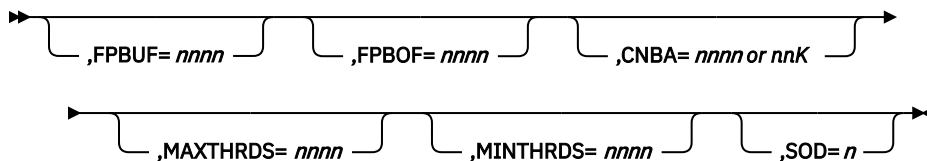

Usage

A CSLDCxxx member of the IMS PROCLIB data set consists of one or more fixed-length character records (the configuration data set can be of any LRECL greater than eight, but it must be fixed record format). The rightmost-eight columns are ignored but can be used for sequence numbers or any other notation. Keyword parameters can be coded in the remaining columns in free format, and they can contain leading and trailing blanks. You can specify multiple keywords in each record; use commas or spaces to delimit keywords. Statements that begin with a “*” or “#” in column 1 are comment lines and are ignored. Additionally, comments can be included anywhere within a statement by enclosing them between “/*” and “*/”, for example, /* PROCLIB comments */. Values coded in this member of the IMS PROCLIB data set are case sensitive. In general, you should use uppercase for all parameters.

Parameters

The parameters on the CSLDCxxx member of the IMS PROCLIB data set include those that can be specified only in the global section, those that can be specified only in the local section, and those that can be specified in either the global section, the local section, or both.

Parameters that can be specified as a global default and as an instance-specific override of the default value

The following parameters can be specified in both the global and the local sections of CSLDCxxx. When specified in the global section, these parameters define the default value for the parameter on all data store connections defined on the CSLDCxxx member of the IMS PROCLIB data set. When specified in the local section, these parameters apply only to the specified data store connection of a specified instance of ODBM and override the global specifications.

MAXTHRDS=nnnn

Specifies the maximum number of concurrent active threads for an individual IMS data store. Valid values for MAXTHRDS are from 1 to 4095. The default value for MAXTHRDS is 1.

Values for MAXTHRDS specified in the local section of CSLDCxxx override the value of MAXTHRDS from the global section.

MINTHRDS=nnnn

Specifies the minimum number of concurrent active threads for an individual IMS data store. Valid values for MINTHRDS are from 1 to 4095.

If the MINTHRDS is not explicitly specified in the CSLDCxxx member of the IMS PROCLIB data set, MINTHRDS is set to 62% of the value of MAXTHRDS.

Values for MINTHRDS specified in the local section of the CSLDCxxx member of the IMS PROCLIB data set override the value of MINTHRDS from the global section.

DIAGDPSBMSG=SHORT | LONG | NONE

Specifies the value of the DIAGDPSBMSG= parameter to control ODBM issuing the CSL4202W or CSL4203W message after an internal DPSB request from ICON is received.

The parameters specify the following:

- *SHORT*: Specifies that the CSL4202W message is to be issued. This is the default.
- *LONG*: Specifies that the CSL4203W message is to be issued.
- *NONE*: Specifies no CSL4202W or CSL4203W message is to be issued after the CSL4201W message.

FPBUF=nnnn

Specifies the number of Fast Path DEDB buffers that are allocated per thread. Valid values for FPBUF are from 0 to 9999. The default value for FPBUF is 0.

FPBOF=nnnn

Specifies the number of Fast Path DEDB overflow buffers to be allocated per thread. Valid values for FPBOF are from 0 to 9999. The default value for FPBOF is 0.

Values for FPBOF specified in the local section of CSLDCxxx override the value of FPBOF from the global section.

CNBA=nnnn or nnK

Specifies the total number of Fast Path NBA buffers for ODBM use. Valid values for CNBA are from 0 to 9999 and 1K to 32K. The default value for CNBA is 0.

Values for CNBA specified in the local section of CSLDCxxx override the value of CNBA from the global section.

You can determine a starting value for CNBA by using the following formula: $FPBUF \times MAXTHRDS + FPBOF = CNBA$. If needed, adjust the value of CNBA to meet the performance and storage requirements of your installation.

If $FPBUF > 0$ or $FPBOF > 0$, and $CNBA = 0$, the IMS system calculates the CNBA size during connection request processing by using the formula.

SOD=n

Specifies the system output class of SNAP dumps that can be produced by the ODBM address space. Valid values for SOD are any single alphanumeric character. The default value is A.

Values for SOD specified in the local section of CSLDCxxx override the value of SOD from the global section.

Parameters that can be specified only as global defaults

The following parameters can be specified only in the global section of the CSLDCxxx member of the IMS PROCLIB data set. Their values apply to all data store statements included in the CSLDCxxx member of the IMS PROCLIB data set.

<SECTION=GLOBAL_DATASTORE_CONFIGURATION>

Required header for the global section of the CSLDCxxx member of the IMS PROCLIB data set.

IDRETRY=nnn

Specifies the number of times that ODBM attempts to connect to an IMS data store if the first connection attempt fails. Valid values for IDRETRY are from 0 to 255. The default value is 0. IDRETRY is an optional parameter.

TIMER=nn

Specifies the number of seconds that ODBM waits between connection attempts if the first attempt to connect to an IMS data store by ODBM fails and the value of IDRETRY is greater than 0. Valid values for TIMER are from 1 to 99. The default value for TIMER is 60.

Parameters that can be specified only as instance-specific values

<SECTION=LOCAL_DATASTORE_CONFIGURATION>

Required header for the local section of the CSLDCxxx member of the IMS PROCLIB data set.

ODBM()

Contains the attribute specifications for the data store connections of a specific instance of ODBM.

NAME=odbmname

Identifies the ODBM instance to which the included data store statements apply.

DATASTORE()

Defines an IMS data store that can be connected to by this ODBM. You must include at least one DATASTORE statement in the CSLDCxxx member of the IMS PROCLIB data set.

NAME=imsid

Specifies the 1- to 4-character alphanumeric IMSID of an IMS data store that ODBM can connect to. This parameter is required for each DATASTORE parameter. There is no default for this parameter.

ALIAS()

Specifies one or more ALIAS names for the data store defined by the DATASTORE statement. Application programs must use an alias name to access IMS data stores and do not need to know the actual IMSID of the IMS data store. If an application program wants to access an IMS data store using the DATASTORE name, that name must be specified as an ALIAS or be an internal alias.

For a DATASTORE statement, an associated ALIAS parameter is not required. If no ALIAS parameter is specified, ODBM generates an internal alias, giving it the data store name specified in the DATASTORE NAME parameter. This allows application programs to use the data store name when making calls to that data store.

These internally generated aliases cannot be started or stopped by using the following commands:

- UPD ODBM START(CONNECTION) ALIAS(*internal_alias_name*)
- UPD ODBM STOP(CONNECTION) ALIAS(*internal_alias_name*)

Starting or stopping a connection for a data store with an internally generated alias can only be achieved by starting or stopping the data store itself.

When displaying ODBM configuration and status, none of the internally generated aliases appear in any output resulting from a QRY ODBM command.

NAME=aliasname

Specifies a 4-character alphanumeric alias name.

You can specify multiple alias names on a DATASTORE statement, which allows different application programs to access the same IMS data store by using different alias names. For

each instance of ODBM, many alias names may be associated with a data store, and an alias name may be associated with more than one data store.

For more information about defining Fast Path buffers, see the information about designing and tuning Fast Path databases in *IMS Version 15.4 Database Administration*.

Examples

An example of the CSLDCxxx members of the IMS PROCLIB data set is shown below.

```
*****
* CSLDC000 ODBM CSL PROCLIB MEMBER *
*****

<SECTION=GLOBAL_DATASTORE_CONFIGURATION>

IDRETRY=5                /* Retry connection 5 times before quit */
MAXTHRDS=10             /* 10 threads max to any IMS Datastore */
TIMER=30                /* 30 seconds between ID retry attempts */
FPBUF=10                /* 10 DEDB buffers per thread */
FPBOF=10                /* 10 Overflow buffers per thread */
CNBA=200                /* (FPBUF+FPBOF)*MAXTHRDS <= CNBA */
/*****
/* Define DATASTORE properties for ODBM01 */
*****/

<SECTION=LOCAL_DATASTORE_CONFIGURATION>
ODBM(NAME=ODBM01,       /* Define parms for ODBM01 */
  DATASTORE (NAME=IMS1, /* IMSID on LPAR A */
    ALIAS (NAME=IO1A,NAME=IO1B), /* Names for APPL sets 1 & 2 */
    FPBUF=0,FPBOF=0,CNBA=0 /* No FastPath on this IMS */
  )
  DATASTORE (NAME=IMS2, /* IMSID on LPAR A */
    ALIAS (NAME=IO2A,NAME=IO2B), /* Names for DEDB apps */
    FPBUF=50,FPBOF=50,CNBA=500, /* FastPath on this IMS */
    MAXTHRDS=5 /* Throttle down threads */
  )
)
/*****
/* Define DATASTORE properties for ODBM02 */
*****/
/*****
/* Define parms for ODBM02 */
*****/
ODBM(NAME=ODBM02,
  DATASTORE (NAME=IMS3, /* IMSID on LPAR B */
    ALIAS (NAME=IO3A,NAME=IO3B) /* Names for APPL sets 3 & 4 */
  )
)
/* Take globals for the rest */
```

Related concepts

[“IMS Syntax Checker” on page 381](#)

The Syntax Checker is an ISPF application that helps you define, verify, and validate parameters and their values in the members of the IMS PROCLIB data set. Use the IMS Syntax Checker to avoid typographical and syntactical errors when modifying the parameter values for the IMS PROCLIB data set members.

CSLDIxxx member of the IMS PROCLIB data set

Use the ODBM initialization member of the IMS PROCLIB data set (CSLDIxxx) to specify parameters that initialize the ODBM address space.

You can use the IMS Syntax Checker to modify this member of the IMS PROCLIB data set.

Syntax

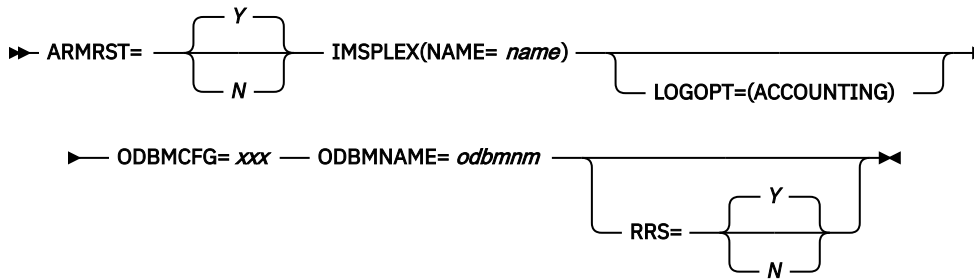

Usage

A CSLDIxxx member consists of one or more fixed-length character records (the configuration data set can be of any LRECL greater than eight, but it must be fixed record format). The rightmost-eight columns are ignored but can be used for sequence numbers or any other notation. Keyword parameters can be coded in the remaining columns in free format, and can contain leading and trailing blanks. You can specify multiple keywords in each record; use commas or spaces to delimit keywords. Statements that begin with a "*" or "#" in column 1 are comment lines and are ignored. Additionally, comments can be included anywhere within a statement by enclosing them between "/" and "*/", for example, /* PROCLIB comments */. Values coded in this member of the IMS PROCLIB data set are case sensitive. In general, you should use uppercase for all parameters.

The ARMST, ODBMCFG, ODBMNAME, and RRS parameters can also be specified as execution parameters in the CSLODBM procedure. When they are specified as execution parameters, the values of the execution parameters override the values of the parameters specified in the CSLDIxxx member of the IMS PROCLIB data set. For more information about the ODBM execution parameters, see "[CSLODBM procedure](#)" on page 595.

Note that, in addition to determining whether ODBM uses the z/OS Resource Recovery Services (RRS), the RRS parameter also determines whether ODBM uses the Open Database Access (ODBA) interface or the database resource adapter (DRA) interface. When RRS=Y, ODBM uses RRS and the ODBA interface.

BPE considerations

Use the ODBM BPE user exit list member of the IMS PROCLIB data set to define ODBM user exits to BPE. This is the member of the IMS PROCLIB data set specified by the EXITMBR= parameter in the BPE configuration parameter member of the IMS PROCLIB data set.

Use the user exit list member of the IMS PROCLIB data set to specify the modules to be called for specific exit types. Each user exit type can have one or more exit modules associated with it. Use the EXITDEF statement to define the user exit modules to be called for a given exit type.

Parameters

ARMST= Y | N

Specifies whether the z/OS Automatic Restart Manager (ARM) is to be used to restart the ODBM address space after an abend. If you specify Y (yes), ARM restarts the ODBM address space after most system failures. If you specify N (no), ARM does not restart the ODBM address space after any system failure.

ARM does not restart the ODBM address space if ODBM abends before restart is complete. For more information about ARM, see [The z/OS Automatic Restart Manager \(ARM\) \(System Administration\)](#) in *IMS Version 15.4 System Administration*.

IMSPLEX()

Specifies definitions for the IMSplex in which ODBM is a member. IMSPLEX is a required parameter. There is no default. Only one IMSPLEX keyword can be specified. The IMSPLEX keyword must precede the left parenthesis. The IMSPLEX definition parameters follow:

NAME=

A 1- to 5-character user-specified identifier that is concatenated to 'CSL' to create the cross-system coupling facility (z/OS cross-system coupling facility) CSL IMSPLEX group name. The value specified here must match the IMSPLEX NAME= value specified in the SCI startup procedure. All IMS address spaces, such as OM, RM, SCI, IMS, ODBM, and so on, that are in the same IMSplex sharing group, sharing either databases or message queues, must specify the same identifier. The same identifier must also be used for the IMSPLEX= parameter in the CSLSIxxx, CSLRIxxx, CSLOIxxx, and DFSCGxxx members of the IMS PROCLIB data set.

LOGOPT=()

An optional keyword that specifies the level of logging for individual ODBMs. This parameter is used during the initialization of the ODBM CSL address space. If not specified, no logging occurs.

ACCOUNTING

Specifies that ODBM usage information is logged.

ODBMCFG= 000 | xxx

Specifies the 3-character suffix for the ODBM configuration member of the IMS PROCLIB data set, CSLDCxxx, that contains definitions for ODBA connection initialization parameters and any ODBM configuration statements. The default suffix is 000.

ODBMNAME= odbmnm

Specifies the 1- to 6-character name of the ODBM address space. You can specify the ODBMNAME parameter on either the CSLODBM startup procedure or in the CSLDIxxx member of the IMS PROCLIB data set. Each instance of ODBM in an IMSplex must have a unique ODBMNAME.

For each ODBMNAME, ODBM creates an eight-character ODBMID that identifies the instance of ODBM within the IMSplex. The ODBMID is the ODBMNAME followed by the characters "OD" and any blank spaces that ODBM needs to add to make the ODBMID eight characters in length.

For example, if you specify an ODBMNAME that is three characters long, ODBM creates the eight-character ODBMID by appending the characters OD to the ODBMNAME and then padding the ODBMID with three blank spaces. If ODBMNAME=ABC, ODBM creates an ODBMID of "ABCOD_ _ _", in which _ represents a blank space.

If you specify the ODBMNAME parameter in the CSLDIxxx member of the IMS PROCLIB data set, you must also either define a separate CSLDIxxx member for each instance of ODBM in an IMSplex or specify ODBMNAME in the startup procedure for each instance of ODBM in the IMSplex.

RRS= Y | N

An optional keyword that specifies both whether ODBM uses RRS and whether ODBM uses the Open Database Access (ODBA) interface or the DRA for communications with IMS DB.

If you specify Y, ODBM uses RRS and the ODBA interface. If ODBM cannot register with RRMS during initialization, ODBM issues message CSL4001A and suspends initialization until the operator responds to the message.

If you specify N, ODBM does not use RRS and uses the DRA interface for communications with IMS DB. When RRS=N is specified, ODBM interfaces with IMS DB in a similar manner as a CCTL.

For more information, see [ODBM and RRS \(System Administration\)](#) in *IMS Version 15.4 System Administration*.

Examples

A sample ODBM initialization member of the IMS PROCLIB data set is shown in the following example. The sample, called CSLDI000, is provided as part of the IMS PROCLIB data set.

```
*****
* CSLDI000 ODBM CSL PROCLIB MEMBER *
*****
ARMRST=Y /* ARM should restart ODBM on failure */
ODBMCFG=000 /* Suffix for CSLDC000 config member */
ODBMNAME=ODBM1 /* ODBM name (ODBM id = ODBM10D) */
```

```

IMSPLEX(NAME=PLEX1)          /* GROUP NAME (XCF group = CSLPLEX1) */
LOGOPT=(ACCOUNTING)         /* Log Accounting information          */

```

A sample ODBM BPE user exit list member of the IMS PROCLIB data set is shown in the following example.

```

*****
* ODBM USER EXIT LIST PROCLIB MEMBER *
*****

#-----#
# DEFINE 1 ODBM INIT/TERM USER EXIT: ZDINTM00 #
#-----#
EXITDEF (TYPE=INITTERM,EXITS=(ZDINTM00),COMP=ODBM)

#-----#
# DEFINE 1 ODBM INPUT USER EXIT: ZINPUT00 #
# WITH AN ABEND LIMIT OF 8. #
#-----#
EXITDEF (TYPE=INPUT,EXITS=(ZINPUT00),ABLIM=8,COMP=ODBM)

#-----#
# DEFINE 1 ODBM OUTPUT USER EXIT: ZOUTPUT0 #
#-----#
EXITDEF (TYPE=OUTPUT,EXITS=(ZOUTPUT0),COMP=ODBM)

```

Related concepts

[“IMS Syntax Checker” on page 381](#)

The Syntax Checker is an ISPF application that helps you define, verify, and validate parameters and their values in the members of the IMS PROCLIB data set. Use the IMS Syntax Checker to avoid typographical and syntactical errors when modifying the parameter values for the IMS PROCLIB data set members.

CSLOIxxx member of the IMS PROCLIB data set

Use the CSLOIxxx member of the IMS PROCLIB data set to specify parameters that initialize the Operations Manager (OM) address space.

Some parameters within CSLOIxxx can be overridden with the OM execution parameters.

You can use the IMS Syntax Checker to modify this member of the IMS PROCLIB data set.

Syntax

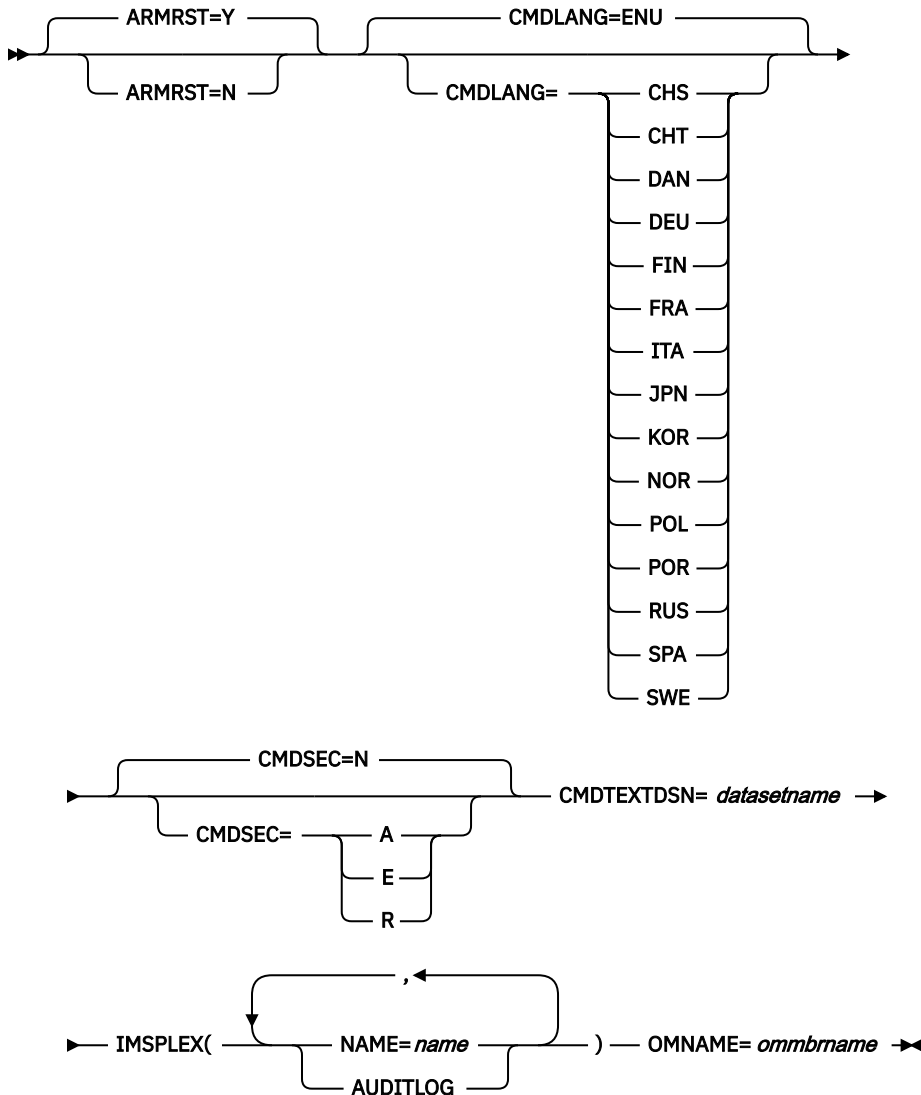

Usage

A CSLOIxxx member consists of one or more fixed-length character records (the configuration data set can be of any LRECL greater than eight, but it must be fixed record format). The rightmost-eight columns are ignored but can be used for sequence numbers or any other notation. Keyword parameters can be coded in the remaining columns in free format, and can contain leading and trailing blanks. You can specify multiple keywords in each record; use commas or spaces to delimit keywords. Statements that begin with a * or # in column 1 are comment lines and are ignored. Additionally, comments can be included anywhere within a statement by enclosing them between /* and */, for example,

```
/* PROCLIB comments */
```

Values coded in this member of the IMS PROCLIB data set are case-sensitive. In general, use uppercase for all parameters.

BPE considerations

Use the OM BPE user exit list member of the IMS PROCLIB data set to define OM user exits to BPE. This is the member of the IMS PROCLIB data set specified by the EXITMBR= parameter in the BPE configuration parameter member of the IMS PROCLIB data set.

Use the user exit list member of the IMS PROCLIB data set to specify the modules to be called for specific exit types. Each user exit type can have one or more exit modules associated with it. Use the EXITDEF statement to define the user exit modules to be called for a given exit type.

A sample OM BPE user exit list member of the IMS PROCLIB data set is shown in [“Sample OM user exit list member of the IMS PROCLIB data set”](#) on page 718.

A sample CSLOIxxx member of the IMS PROCLIB data set is shown in [“Sample CSLOIxxx member of the IMS PROCLIB data set”](#) on page 718. The sample, called CSLOI000, is provided as part of the IMS PROCLIB data set.

Parameters

ARMRST= Y | N

An optional keyword that you use to specify whether the z/OS Automatic Restart Manager (ARM) is to be used to restart the OM address space after an abend. If you specify Y (yes), ARM restarts the OM address space after most system failures. If you specify N (no), ARM does not restart the OM address space after any system failure.

ARM does not restart the OM address space if OM ends abnormally before restart is complete.

CMDLANG=

An optional keyword that you use to specify the language to be used for IMS command text that is distributed to OM automation clients upon request. This affects only the command descriptions that are displayed on a workstation SPOC that requests command text from OM. This value defaults to ENU for US English.

The value is not validated at OM initialization time. It is only validated when a CSLQMRY QUERY TYPE (CMDSTNTAX) request is issued. OM attempts to read a PDS member in the data set specified by the CMDTEXTDSN= with a member name of "CSLOT" concatenated with the 3-character CMDLANG= value. This is the member that contains the command syntax translatable text. The CMDLANG= value can be overridden on the CSLQMRY request.

This parameter can be specified as an execution parameter on the OM procedure to override the value in CSLOIxxx.

The possible values for this parameter are:

CHS

Simplified Chinese

CHT

Traditional Chinese

DAN

Danish

DEU

German

ENU

English

FIN

Finnish

FRA

French

ITA

Italian

JPN

Japanese

KOR

Korean

NOR
Norwegian

POL
Polish

POR
Portuguese

RUS
Russian

SPA
Spanish

SWE
Swedish

CMDSEC=

An optional keyword that you use to specify the security method to be used for OM command security.

A
Specifies that both RACF (or an equivalent security product) and the exit are to be called (options E and R). RACF is called first. Then the security authorization facility (SAF) return code, RACF return code, and RACF reason code are passed to the exit. These return codes are decoded into a security code, which is also passed to the exit for processing.

E
Specifies that the OM Security user exit routine is to be called for command authorization.

N
Specifies that no authorization checking is to be done. This is the default.

R
Specifies that RACF (or an equivalent security product) is to be called for command authorization.

CMDTEXTDSN=

Specifies the data set name for the PDS that contains the command syntax translatable text. This keyword is required. The parameter value is the 1-44 character data set name. The data set must be a PDS with fixed-length record members.

If you specified, for example, CMDTEXTDSN=IMSBLD.IMS11R.SDFSDATA and CMDLANG=SPA (for Spanish language command text), the text would be located in PDS member IMSBLD.IMS11R.SDFSDATA(CSLOTSPA).

IMSPLEX()

Specifies definitions for an IMSplex managed by OM. IMSPLEX is a required parameter. There is no default. Only one IMSPLEX keyword can be specified. The IMSPLEX keyword must precede the left parenthesis. The IMSPLEX definition parameters follow:

NAME=

Specifies a 1-5 character identifier that specifies the IMSplex group name. OM concatenates this identifier to "CSL" to create the IMSplex group name. All IMSplex member address spaces that are in the same IMSplex group sharing either databases or message queues must specify the same identifier. The same identifier must also be used for the IMSPLEX= parameter in the CSLSIxxx, CSLRIxxx, and DFSCGxxx members of the IMS PROCLIB data set.

AUDITLOG=

An optional 1- to 26-character name of the z/OS log stream to which OM writes input and output information about commands, command responses, and unsolicited messages. The information in this log stream tells you where commands originate, what the command processed, and the result of that processing. You cannot issue this parameter as an OM execution parameter.

The audit trail log stream SYSLOG.OM2Q01.LOG is defined as part of the IVP and is then associated with the AUDITLOG= parameter of the IVP sample job.

In the following scenarios, no data is lost in the OM audit trail when the log stream becomes available because OM logs its work:

- If the connection to the log stream fails at startup, the initialization continues. Connection is set up after the log stream becomes available.
- If writing to the log stream fails for OM, OM waits for the log stream to become available and performs the writing process again.

Requirement: The following SAF security rules must be defined to support the use of the OM audit trail:

- The OM address space has FAC (facility) access to the structure.
- The OM address space has access to the log stream. This access can be accomplished using an SAF rule.
- Any user reading the log stream must have SAF read access.

OMNAME=omnbrname

Specifies the name for the OM address space. This is an optional 1-6 character name. Specify this parameter either as an execution parameter or in the CSLOIxxx member of the IMS PROCLIB data set. This name is used to create the OMID which is used in OM processing. The 8-character OMID is the OMNAME followed by the characters "OM". Trailing blanks in the OMNAME are deleted and the OMID is padded with blanks. For example, if OMNAME=ABC then OMID="ABCOM ".

Sample OM user exit list member of the IMS PROCLIB data set

```
*****
* OM USER EXIT LIST PROCLIB MEMBER *
*****

#-----#
# DEFINE 1 OM CLIENT CONNECTION USER EXIT: ZOCLNCO#
#-----#
EXITDEF (TYPE=CLNTCONN,EXITS=(ZOCLNCO),COMP=OM)

#-----#
# DEFINE 1 OM INIT/TERM USER EXIT: ZOINTMO#
#-----#
EXITDEF (TYPE=INITTERM,EXITS=(ZOINTMO),COMP=OM)

#-----#
# DEFINE 1 OM INPUT USER EXIT: ZINPUTO#
# WITH AN ABEND LIMIT OF 8.#
#-----#
EXITDEF (TYPE=INPUT,EXITS=(ZINPUTO),ABLIM=8,COMP=OM)

#-----#
# DEFINE 1 OM OUTPUT USER EXIT: ZOOUTPO#
#-----#
EXITDEF (TYPE=OUTPUT,EXITS=(ZOOUTPO),COMP=OM)

#-----#
# DEFINE 1 OM SECURITY USER EXIT: ZSECO#
#-----#
EXITDEF (TYPE=SECURITY,EXITS=(ZSECO),COMP=OM)
```

Sample CSLOIxxx member of the IMS PROCLIB data set

```
*-----*
* Sample OM Initialization PROCLIB member. *
*-----*

ARMRST=Y, /* ARM should restart OM on failure */
CMDLANG=ENU, /* Use English for Command Desc */
CMDSEC=N, /* No Command Security */
OMNAME=OM1, /* OM Name (OMID = OM1OM) */
IMSPLEX(NAME=PLEX1) /* IMSplex Name (CSLPLEX1) */
CMDTEXTDSN=IMSTESTG.DUMMY.TRNTBL /* CMD Syntax Translation Table */

*-----*
* End of Member CSLOI000 *
*-----*
```

Related concepts

[“IMS Syntax Checker” on page 381](#)

The Syntax Checker is an ISPF application that helps you define, verify, and validate parameters and their values in the members of the IMS PROCLIB data set. Use the IMS Syntax Checker to avoid typographical and syntactical errors when modifying the parameter values for the IMS PROCLIB data set members.

[The z/OS Automatic Restart Manager \(ARM\) \(System Administration\)](#)

CSLRxxxx member of the IMS PROCLIB data set

Use the CSLRxxxx member of the IMS PROCLIB data set to specify parameters that initialize RM.

You can use the IMS Syntax Checker to modify this member of the IMS PROCLIB data set.

Syntax

Some parameters within CSLRxxxx can be overridden with RM execution parameters.

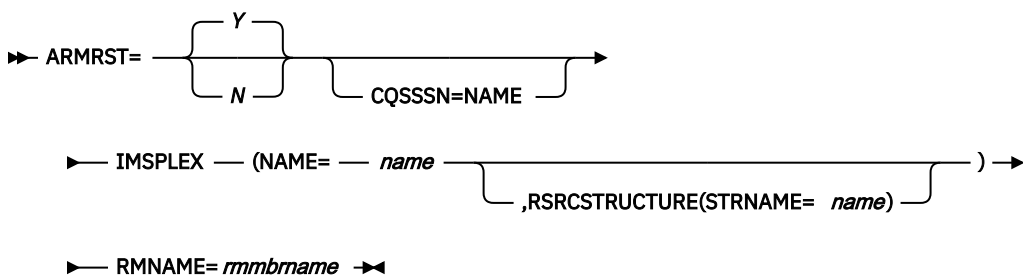

Execution parameters for the IMSRSC repository are specified within a section with the header `<SECTION=REPOSITORY>`. This section is included after the other CSLRxxxx parameters.

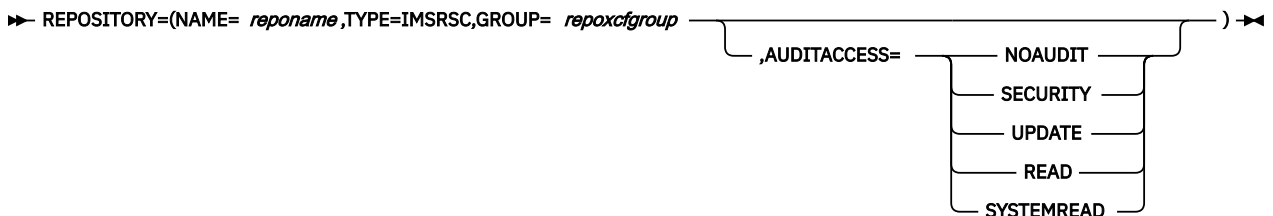

Usage

The CSLRxxxx member of the IMS PROCLIB data set consists of one or more fixed-length character records (the configuration data set can be of any LRECL greater than eight, but it must be fixed record format). The rightmost-eight columns are ignored but can be used for sequence numbers or any other notation. Keyword parameters can be coded in the remaining columns in free format, and can contain leading and trailing blanks. You can specify multiple keywords in each record; use commas or spaces to delimit keywords. Statements that begin with a "*" or "#" in column 1 are comment lines and are ignored. Additionally, comments can be included anywhere within a statement by enclosing them between "/*" and "*/", for example, `/* PROCLIB comments */`. Values coded in this member of the IMS PROCLIB data set are case sensitive. In general, you should use uppercase for all parameters.

A sample CSLRxxxx member of the IMS PROCLIB data set is shown in [“Sample CSLRxxxx member of the IMS PROCLIB data set” on page 722](#).

BPE considerations

Use the RM BPE user exit list member of the IMS PROCLIB data set to define RM user exits to BPE. This is the member of the IMS PROCLIB data set specified by the `EXITMBR=` parameter in the BPE configuration parameter member of the IMS PROCLIB data set.

Use the user exit list member of the IMS PROCLIB data set to specify the modules to be called for specific exit types. Each user exit type can have one or more exit modules associated with it. Use the EXITDEF statement to define the user exit modules to be called for a given exit type.

A sample RM user exit list member of the IMS PROCLIB data set is shown in [“Sample RM user exit member of the IMS PROCLIB data set”](#) on page 722.

Parameters

ARMRST= Y | N

Specifies whether the z/OS Automatic Restart Manager (ARM) should be used to restart RM after an abend. Y (yes) specifies that ARM should be used. The RM address space is restarted by ARM after most system failures. N (no) specifies that ARM should not be used. RM is not restarted by ARM after any failures. For information about ARM, see [The z/OS Automatic Restart Manager \(ARM\) \(System Administration\)](#) in *IMS Version 15.4 System Administration*.

CQSSN=

Specifies the one- to four-character subsystem name of the CQS. RM uses this name to connect to the proper CQS. When connecting RM to CQS, you must specify the same value on CQSSN= and on the SSN= parameter of the CQSIPxxx member of the IMS PROCLIB data set for the target CQS. The parameter is optional, and no default exists. Both CQSSN and RSRCSTRUCTURE must be specified together, or neither must be specified. CQSSN and RSRCSTRUCTURE must be specified to use RM's global resource services.

IMSPLEX()

Specifies definitions for an IMSplex managed by RM. IMSPLEX is a required parameter. There is no default. Only one IMSPLEX keyword can be specified. The IMSPLEX keyword must precede the left parenthesis. The IMSPLEX definition parameters follow:

NAME=

Specifies a 1-5 character identifier that specifies the IMSplex group name. This defines the IMSplex to which the resource structure is defined. NAME is required and no default exists. RM concatenates this identifier to "CSL" to create the IMSplex group name. All OM, RM, SCI, IMS, and IMSplex members that are in the same IMSplex sharing group sharing either databases or message queues must specify the same identifier. The same identifier must also be used for the IMSPLEX= parameter in the CSLSIxxx, CSLOIxxx, and DFSCGxxx members of the IMS PROCLIB data set.

RSRCSTRUCTURE()

Specifies definitions for a resource structure managed by RM. This keyword construct is optional. RSRCSTRUCTURE must be specified to use RM's global resource services. Only one resource structure can be defined. The resource structure definitions must be enclosed within parentheses and separated by commas. The RSRCSTRUCTURE keyword must precede the left parenthesis.

STRNAME=

Specifies the 1- to 16-character name of a resource structure that IMS connects to, which contains IMS resource information. If the RSRSTRUCTURE construct is specified, then STRNAME is required within the RSRCSTRUCTURE construct.

The installation must have defined the structure name in the CFRM administrative policy. The structure name must follow the naming rules as allowed by the CFRM. The structure name must be from 1- to 16-characters long. For names with less than 16 characters, CQS pads the name with blanks. The valid characters are A-Z, 0-9 and the following special characters:

```
$ @ # _
```

Names must be uppercase and start with an alphabetic character. This resource structure must also be defined in the CQS global structure definition member of the IMS PROCLIB data set (CQSSGxxx) of the CQS in the same IMSplex sharing group. This resource structure must also be defined in the CFRM policy.

Restriction: Avoid using names that IBM uses for its structures. Do not begin structure names with the letters A-I, or with the character string SYS. If you do name a structure beginning

with the letters A-I or SYS, your name might conflict with an existing or future IBM-defined structure name.

REPOSITORY=()

Defines the IMSRSC repository parameters for RM initialization. It is specified within a section with the header <SECTION=REPOSITORY>.

NAME=

Specifies the repository name that is managed by RM. This name must be same as the repository name defined to the Repository Server (RS) in the ADD REPOSITORY function. The repository name can be up to 44 characters long and can contain the alphanumeric characters (A–Z, 0 - 9) and the following symbols: period (.) at sign (@), number sign (#), underscore (_), and dollar sign (\$).

Note: The alphabetic characters A–Z can be uppercase only.

A repository name of CATALOG cannot be specified, because it is reserved for use by the RS.

TYPE=

Specifies the repository type. The only valid value is IMSRSC.

GROUP=

Specifies the RS z/OS cross-system coupling facility group name. This value must be the same as the XCF group name specified on the XCF_GROUP_NAME parameter of the FRPCFG member of the IMS PROCLIB data set. RM and the RS must be in the same XCF group. The value must be 8 characters padded on the right with blanks. Valid characters are A-Z (uppercase only), 0 - 9, and the following symbols: number sign (#), dollar sign (\$), and at sign (@).

AUDITACCESS=

An optional parameter. It is used if the RS is enabled with the audit log (AUDIT=YES is specified in the FRPCFG member of the IMS PROCLIB data set). If the RS is not enabled with the audit log, the AUDITACCESS value in RM is set to NOAUDIT.

AUDITACCESS specifies the audit access level for the specified repository. If this value is not specified, the audit access level defaults to the level of auditing set by the AUDIT_DEFAULT= parameter in the FRPCFG member of the IMS PROCLIB data set. The valid values for the AUDITACCESS= parameter are:

DEFAULT

Use the rule specified in the AUDIT_DEFAULT parameter of the FRPCFG member.

NOAUDIT

No auditing of member access.

SECURITY

Audit security failures only.

UPDATE

Audit member access with update intent.

READ

Audit member access with read or update intent.

SYSTEMREAD

Audit member access with system-level read, read, or update intent.

A read request from an authorized client before an update is identified as a *system read* request.

Under an audit access rule of READ, system read requests do not cause a read audit record to be generated.

Under an audit access rule of SYSTEMREAD, all read requests, including system read requests, are audited.

RMNAME=rmmbrname

Specifies the name for the RM address space. This is an optional 1- to 6-character name. You must specify this parameter either as an execution parameter or in the CSLRIxxx member of the IMS PROCLIB data set. This name is used to create the RMID, which is used in RM processing. The

8-character RMID is the RMNAME followed by the characters "RM". Trailing blanks in the RMNAME are deleted, and the RMID is padded with blanks. For example, if RMNAME=ABC then RMID="ABCRM ".

Sample CSLRIxxx member of the IMS PROCLIB data set

```

*-----*
* Sample RM Initialization PROCLIB member. *
*-----*

ARMRST=Y, /* ARM should restart RM on failure */
CQSSSN=CQS1, /* CQS to manage Resource Structure */
IMSPLEX(
  NAME=PLEX1, /* IMSplex name (CSLPLEX1) */
  RSRCSTRUCTURE(
    STRNAME=IMSRSC01), /* RESOURCE STRUCTURE NAME */
RMNAME=RM1 /* RM Name (RMID = RM1RM) */
*-----*
* Repository Section *
*-----*
<SECTION=REPOSITORY>
REPOSITORY=(NAME=IMSRSC_REPOSITORY,TYPE=IMSRSC,GROUP=FRPGRUP1)
*-----*
* End of Member CSLRI000 *
*-----*

```

Sample RM user exit member of the IMS PROCLIB data set

```

*****
* RM USER EXIT LIST PROCLIB MEMBER *
*****

#-----#
# DEFINE 1 RM CLIENT CONNECTION USER EXIT: ZRCLNCN0 #
# WITH AN ABEND LIMIT OF 8. #
#-----#
EXITDEF (TYPE=CLNTCONN,EXITS=(ZRCLNCN0),ABLIM=8,COMP=RM)

#-----#
# DEFINE 1 RM INIT/TERM USER EXIT: ZRINTM00 #
#-----#
EXITDEF (TYPE=INITTERM,EXITS=(ZRINTM00),COMP=RM)

```

Related concepts

[“Overview of the IMSRSC repository” on page 37](#)

A repository is a generalized data storage facility that can be used to store any type of information. The IMS resource definition (IMSRSC) repository is a set of VSAM key sequenced data sets (KSDSs) used for storing information. The IMSRSC repository is a repository to store resource (and descriptor) definitions for IMS databases, transactions, programs, and routing codes. This repository is an alternative to the resource definition data set (RDDS) that is used with the dynamic resource definition (DRD) function.

[CSL RM initialization with the IMSRSC repository \(System Administration\)](#)

[Repository Server audit log records \(Diagnosis\)](#)

[Managing Repository Server audit log records \(Diagnosis\)](#)

[Authorizing connections to CQS structures \(System Administration\)](#)

[“IMS Syntax Checker” on page 381](#)

The Syntax Checker is an ISPF application that helps you define, verify, and validate parameters and their values in the members of the IMS PROCLIB data set. Use the IMS Syntax Checker to avoid typographical and syntactical errors when modifying the parameter values for the IMS PROCLIB data set members.

Related tasks

[“Defining the IMSRSC repository” on page 40](#)

Before you can use the IMSRSC repository to store and retrieve resource and descriptor definitions, you must define it. In addition, IMS and the Resource Manager (RM) must have the repository enabled, the Repository Server (RS) must be started and active, and the repository must be started.

Related reference

[“FRPCFG member of the IMS PROCLIB data set” on page 911](#)

Use the FRPCFG member of the IMS PROCLIB data set to define the Repository Server (RS) configuration parameters relating to performance, communications, and security. FRPCFG also identifies the names of the RS catalog repository data sets.

[“BPE configuration parameter member of the IMS PROCLIB data set” on page 665](#)

Use the BPE configuration parameter member of the IMS PROCLIB data set to define BPE execution environment settings such as tracing, language, and statistics time interval settings for an address space that is being started.

[“COMMON_SERVICE_LAYER section of the DFSDFxxx member” on page 762](#)

The COMMON_SERVICE_LAYER section of the DFSDFxxx member of the IMS PROCLIB data set specifies options for the Common Service Layer (CSL), such as IMSplex name, ACB sharing, global online change, command authorization checking, OLCSTAT, DRD, and global resource status. The section is defined by the header <SECTION=COMMON_SERVICE_LAYER>. The COMMON_SERVICE_LAYER section is valid in DB/DC, DBCTL, and DCCTL environments.

[“DFSCGxxx member of the IMS PROCLIB data set” on page 728](#)

Use the DFSCGxxx member of the IMS PROCLIB data set to specify parameters that are related to the Common Service Layer (CSL), including the Operations Manager (OM), the Resource Manager (RM), and the Structured Call Interface (SCI).

[“CSLRM procedure” on page 598](#)

Use the CSLRM procedure to dynamically override the settings in the RM initialization parameters member of the IMS PROCLIB data set (CSLRIxxx).

[“CSLSIxxx member of the IMS PROCLIB data set” on page 723](#)

Use the CSLSIxxx member of the IMS PROCLIB data set to specify parameters related to initialization of the SCI address space.

[“CSLOIxxx member of the IMS PROCLIB data set” on page 714](#)

Use the CSLOIxxx member of the IMS PROCLIB data set to specify parameters that initialize the Operations Manager (OM) address space.

[“CQSSGxxx member of the IMS PROCLIB data set” on page 699](#)

Use the CQSSGxxx member of the IMS PROCLIB data set to define global CQS parameters that are related to one or more coupling facility structures. These parameters are shared by all CQS address spaces that share the structures.

CSLSIxxx member of the IMS PROCLIB data set

Use the CSLSIxxx member of the IMS PROCLIB data set to specify parameters related to initialization of the SCI address space.

Some parameters within CSLSIxxx can be overridden using SCI execution parameters.

You can use the IMS Syntax Checker to modify this member of the IMS PROCLIB data set.

Syntax

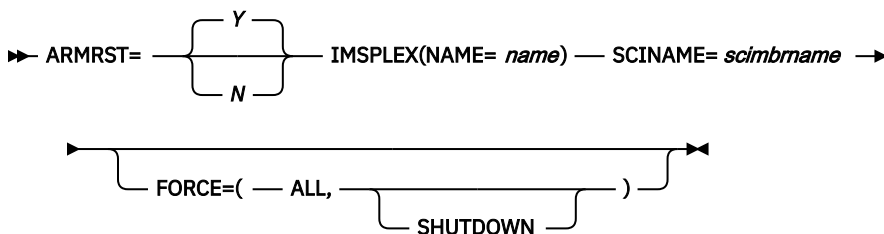

Usage

This member of the IMS PROCLIB data set consists of one or more fixed-length character records (the configuration data set can be of any LRECL greater than eight, but it must be fixed record format). The rightmost-eight columns are ignored but can be used for sequence numbers or any other notation. Keyword parameters can be coded in the remaining columns in free format, and can contain leading and trailing blanks. You can specify multiple keywords in each record; use commas or spaces to delimit keywords. Statements that begin with a "*" or "#" in column 1 are comment lines and are ignored. Additionally, comments can be included anywhere within a statement by enclosing them between " /*" and "*/", for example, /* PROCLIB comments */. Values coded in this member of the IMS PROCLIB data set are case sensitive. In general, you should use uppercase for all parameters.

BPE considerations

Use the SCI BPE user exit list member of the IMS PROCLIB data set to define SCI user exits to BPE. This is the member specified by the EXITMBR= parameter in the BPE configuration parameter member of the IMS PROCLIB data set.

Use the user exit list member of the IMS PROCLIB data set to specify the modules to be called for specific exit types. Each user exit type can have one or more exit modules associated with it. Use the EXITDEF statement to define the user exit modules to be called for a given exit type.

A sample SCI user exit list member of the IMS PROCLIB data set is shown in [“Sample SCI user exit list member of the IMS PROCLIB data set”](#) on page 725.

Parameters

The parameters associated with the syntax diagram are added next.

ARMRST= Y | N

Specifies whether the z/OS Automatic Restart Manager (ARM) should be used to restart the SCI address space after an abend. Y (yes) specifies that ARM should be used. The SCI address space is restarted by ARM after most system failures. N (no) specifies that ARM should not be used. The SCI address space is not restarted by ARM after any failures. For more information about ARM, see [The z/OS Automatic Restart Manager \(ARM\) \(System Administration\)](#) in *IMS Version 15.4 System Administration*.

IMSPLEX()

Specifies definitions for an IMSplex managed by SCI. IMSPLEX is a required parameter. There is no default. Only one IMSPLEX keyword can be specified. The IMSPLEX keyword must precede the left parenthesis. The IMSPLEX definition parameters follow:

NAME=

Specifies a 1- to 5-character name that specifies the IMSplex group name. SCI concatenates this name to "CSL" to create the IMSplex group name. All OM, RM, SCI, IMS, and other address spaces that are in the same IMSplex must specify the same name. This is done by specifying the same name for the IMSPLEX= parameter in the CSLOIxxx, CSLRIxxx, CSLSIxxx, and DFSCGxxx members of the IMS PROCLIB data set.

SCINAME=scimbrname

Specifies the name for the SCI address space. This is an optional 1-6 character name. You must specify this parameter either as an execution parameter or in the CSLSIxxx member of the IMS PROCLIB data set. This name is used to create the SCIID which is used in SCI processing. The 8-character SCIID is the SCINAME followed by the characters "SC". Trailing blanks in the SCINAME are deleted and the SCIID is padded with blanks. For example, if SCINAME=ABC then SCIID="ABCSC".

FORCE=()

Specifies that SCI is to clean up the global interface storage. FORCE is an optional parameter and has no default. The keywords are:

ALL

SCI should delete all the global storage, including control blocks and routines. This keyword is required.

SHUTDOWN

SCI should shut down after cleaning the global storage. This keyword is optional.

No local IMSplex members can be active when the FORCE keyword is used. If a member is active, results are unpredictable. Use the FORCE keyword in the following situations:

- When an IMSplex managed by an SCI on one image is managed by a different SCI. For example, PLEX1 is managed by SCI1. If SCI1 becomes inactive, PLEX1 is managed by SCI2. Before SCI2 is started, use FORCE(ALL,SHUTDOWN) on SCI1 to clean the global storage.
- When an SCI is not reactivated on an image. To clean the global storage, reactive that SCI one final time using the FORCE(ALL, SHUTDOWN) keyword.

Sample CSLSIxxx member of the IMS PROCLIB data set

A sample CSLSIxxx member of the IMS PROCLIB data set is shown in [“Sample CSLSIxxx member of the IMS PROCLIB data set”](#) on page 725.

```
*****
* SCI INITIALIZATION PROCLIB MEMBER *
*****

ARMRST=Y           /* ARM should restart SCI on failure */
IMSPLEX(NAME=PLEX1) /* IMSplex name (CSLPLEX1) */
SCINAME=SCI1       /* SCI name (SCIID = SCI1SC) */
```

Sample SCI user exit list member of the IMS PROCLIB data set

```
*****
* SCI USER EXIT LIST PROCLIB MEMBER *
*****
#-----#
# DEFINE 1 SCI CLIENT CONNECTION USER EXIT: ZSCLNCN0 #
# WITH AN ABEND LIMIT OF 8. #
#-----#
EXITDEF (TYPE=CLNTCONN, EXITS=(ZSCLNCN0), ABLIM=8, COMP=SCI)

#-----#
# DEFINE 1 SCI INIT/TERM USER EXIT: ZSINTM00 #
#-----#
EXITDEF (TYPE=INITTERM, EXITS=(ZSINTM00), COMP=SCI)
```

Related concepts

[“IMS Syntax Checker”](#) on page 381

The Syntax Checker is an ISPF application that helps you define, verify, and validate parameters and their values in the members of the IMS PROCLIB data set. Use the IMS Syntax Checker to avoid typographical and syntactical errors when modifying the parameter values for the IMS PROCLIB data set members.

DBFMSDBx member of the IMS PROCLIB data set

Use the DBFMSDBx member of the IMS PROCLIB data set to specify the Main Storage Databases (MSDBs) to be loaded at startup.

You must have previously placed DBFMSDBx in the library whose DD name is PROCLIB. Several DBFMSDBx members can be present in the library; differentiate them by varying the last character (the suffix, x) of the name. The MSDB= keyword parameter of the IMS procedure specifies the suffix of the particular member to be used at startup.

Environments

This member is not applicable in the DBCTL environment.

Syntax

A DBFMSDBx member consists of one or more 80-character records, each specifying an MSDB to be loaded. The format is:

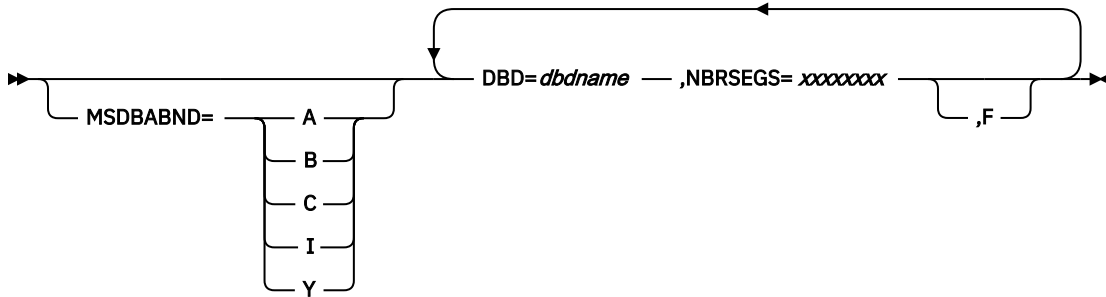

Usage

You can separate keyword parameters with either commas or blanks. Positions 73 through 80 are ignored but can be used to sequence the records. Syntax errors are identified by messages.

At startup, the MSDBs specified by a DBFMSDBx member are loaded from one of the sequential data sets identified as MSDBINIT, MSDBCP1, or MSDBCP2. You cannot, therefore, use the DBFMSDBx member to specify MSDBs that are not included in these data sets; an abend occurs if you use DFSMSDBx in this manner.

Parameters

MSDBABND=

An optional keyword that specifies that the IMS control region is to abend if an error occurs during MSDB loading at system initialization. The valid values for the MSDBABND= parameter are:

A

Valid for both I and C options.

B

Valid for both Y and C options.

C

Abend if initial checkpoint for MSDBs cannot occur.

I

Abend for one or more of the following reasons:

- No segments exist in the MSDBINIT data set for at least one defined MSDB.
- For the reasons described in option Y.

Y

Abend if the MSDBs cannot be loaded due to errors with the MSDBINIT data set.

DBD=

Specifies the same one- to eight-character DBD name as was specified at DBDGEN. Multiple DBD= parameters are allowed.

NBRSEGS=

Specifies the number of database records expected for this MSDB. You must specify a one- to eight-digit number greater than or equal to the number of MSDB segments loaded at restart. By specifying a number greater than the number of segments to be loaded, the parameter can be used to reserve space for a terminal-related dynamic MSDB.

One NBRSEGS= keyword is required for each DBD= keyword that you specify.

F

Optionally specifies that the MSDB is to be page-fixed.

DFS62DTx member of the IMS PROCLIB data set

Use the DFS62DTx member of the IMS PROCLIB data set to store the LU 6.2 device descriptors that are built during IMS initialization.

In the DFS62DTx member of the IMS PROCLIB data set, x is the IMS nucleus suffix. LU 6.2 device descriptors specify an LTERM that associates an output destination with an LU 6.2 device. The system administrator can additionally change applications that use alternate PCBs into applications that use LU 6.2 devices, without application coding changes.

No IMS definition or system definition changes are required to use an LU 6.2 device.

The record format is:

Position

Contents

1

Descriptor type ("U" for user descriptor)

Although this column is not required for an LU 6.2 descriptor, it is included for consistency with ETO descriptors. It is not checked, and no error message is issued if it is omitted.

2

Blank

3-10

Contains the eight-character LTERM name, left-justified and padded with blanks, if necessary. This positional parameter is required, and is used as the descriptor name. A descriptor definition can be continued by repeating the descriptor name in subsequent records. Each individual descriptor can contain up to 50 records (excluding comment records).

11

Blank

12-72

Contains the parameter sets for the descriptor.

73-80

Ignored

DFS62DTx descriptor format

This is the format for the DFS62DTx descriptor. Do not code a parameter in the descriptor and then leave it blank such as (SIDE=b). If you do this, an error message is issued. Instead, omit it completely if you do not need to specify a DFS62DTx descriptor. A descriptor definition can be continued by repeating the descriptor name in subsequent records.

```
U ltermname parm1 parm2 parm n
```

In this example:

U

Indicates user descriptor.

ltermname

The LTERM name.

parm (1...n)

Can be any of the following parameters: SIDE=, MODE=, TPNAME=, SYNCLEVEL=, CONVTYPE=, OUTBND=.

The following is an example of a DFS62DTx descriptor:

```
Column      Column      Column
 1          12          72
U L62TERM1 LUNAME=L62IMS1 TPNAME=CPICTRN1 MODE=L62MDE02
U L62TERM1 SYNCLEVEL=N OUTBND=MYLU02
```

Separate the parameters with a blank.

Keyword descriptions

CONVTYPE=

Specifies whether the conversation type is basic (B) or mapped (M). The default value is M.

LUNAME=

Is a 1- to 17-alphanumeric character (uppercase) name of the destination LU 6.2 application program, which can be a 1- to 17-byte network-qualified LU name. An example of a network-qualified LU name is *netid1.luname1*. If **SIDE=** is specified, **LUNAME** overrides the **LUNAME** in the side information entry. The default is **DFSLU**.

Do not specify a network name for a dependent LU.

MODE=

Is a one- to eight-character name of the VTAM mode table entry to be used. If **SIDE** is specified, **MODE** overrides the mode name in the side information entry. The default is **DFSMODE**.

OUTBND=

Identifies a local LU to be used for outbound message processing.

SIDE=

Is a one- to eight-character alphanumeric name identifying side information entry. (Side information refers to the system-defined values for CPI communications initialization.) If you specify an entry name on this keyword, the **LUNAME**, **TPNAME**, and **MODE** keywords are blank unless you also specify an overriding **LUNAME**, **TPNAME**, or **MODE**. If you do not specify an entry name, the default values apply to the **LUNAME**, **TPNAME**, and **MODE** keywords.

SYNLEVEL=

Specifies whether the APPC/IMS sync level is confirmed (C) or not (N). The default value is C.

TPNAME=

Is a 1- to 64-character name of the transaction program to be scheduled. The default is **DFSASYNC**. If **SIDE=** is specified, **TPNAME** overrides the **TPNAME** in the side information entry.

Recommendation: Use upper-case characters for **TPNAMES** so that the **/ALLOCATE** and **/CHANGE** commands can operate on the resulting messages and descriptors.

DFSCGxxx member of the IMS PROCLIB data set

Use the **DFSCGxxx** member of the IMS PROCLIB data set to specify parameters that are related to the Common Service Layer (CSL), including the Operations Manager (OM), the Resource Manager (RM), and the Structured Call Interface (SCI).

All of the parameters that are valid in the **DFSCGxxx** member of the IMS PROCLIB data set are valid in the **DFSDFxxx** member of the IMS PROCLIB data set. If you specify values in both the **DFSCGxxx** member of the IMS PROCLIB data set and the CSL section of the **DFSDFxxx** member of the IMS PROCLIB data set, the values specified in the **DFSCGxxx** member override the values specified in the **DFSDFxxx** member.

The suffix for **DFSCGxxx**, **xxx**, is specified on the **CSLG=** parameter. All IMSplex members (OM, RM, SCI, IMS, and others) that are in the same IMSplex sharing group, sharing either databases or message queues, must specify the same values.

Environments

The **DFSCGxxx** member of the IMS PROCLIB data set can be used in the IMS DB/DC and DBCTL environments.

Syntax

You can use the IMS Syntax Checker to modify this member of the IMS PROCLIB data set.

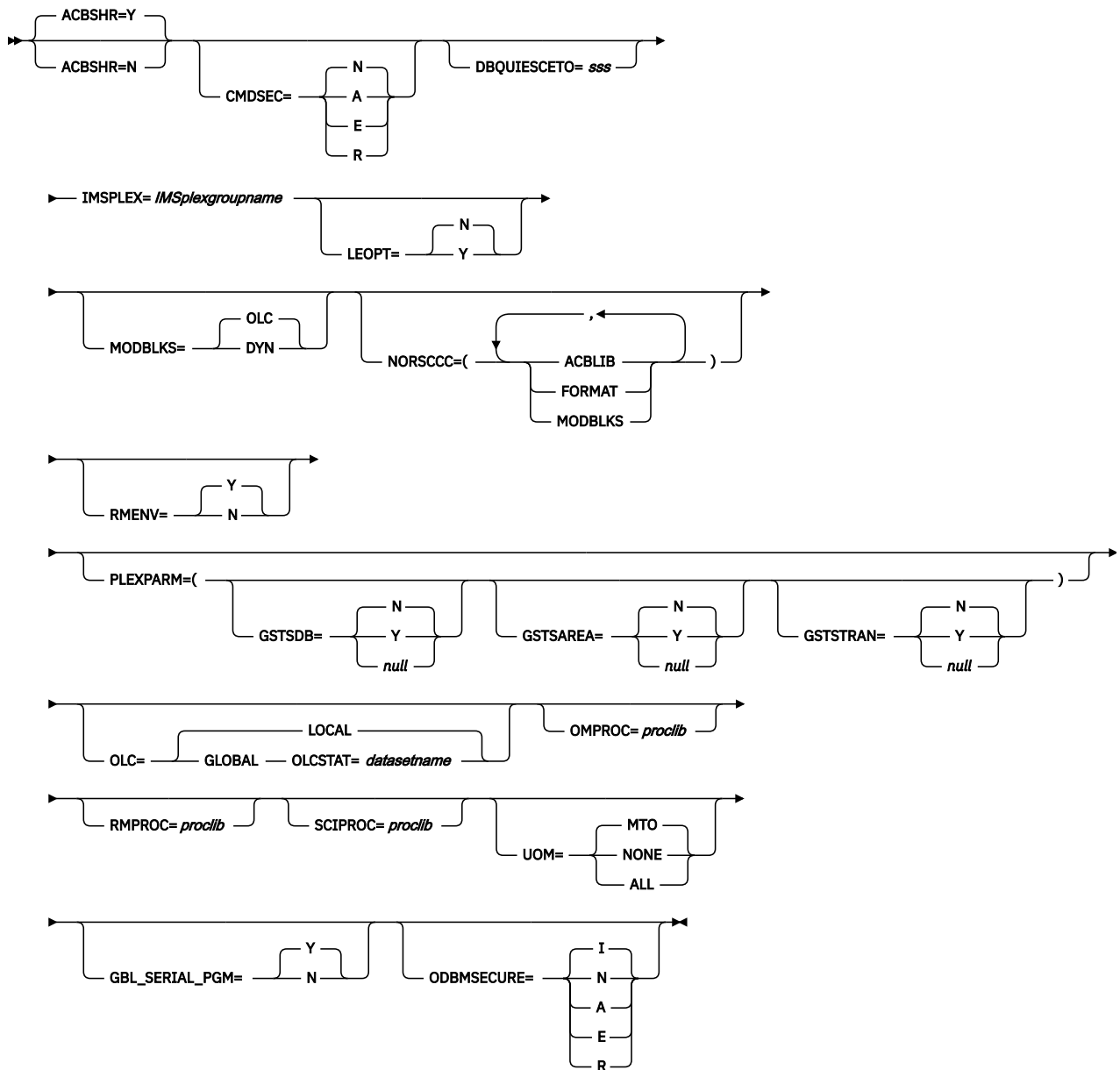

Usage

A DFSCGxxx member consists of one or more fixed-length character records (the configuration data set can be of any LRECL greater than eight, but it must be fixed record format). The rightmost-eight columns are ignored but can be used for sequence numbers or any other notation. Keyword parameters can be coded in the remaining columns in free format, and can contain leading and trailing blanks. You can specify multiple keywords in each record; use commas or spaces to delimit keywords. Statements that begin with a “*” or “#” in column 1 are comment lines and are ignored. Additionally, comments can be included anywhere within a statement by enclosing them between “/*” and “*/”, for example, /* PROCLIB comments */. Values that are coded in this member of the IMS PROCLIB data set are case-sensitive. In general, use uppercase for all parameters.

For installations that do not require Resource Manager services, the DFSCGxxx member of the IMS PROCLIB data set includes parameters (RMENV, OMPROC, and SCIPROC) for specifying that a Resource Manager environment is not required. These parameters are useful if you do not use shared queues or a sysplex, but you would like to issue IMS type-1 and type-2 commands through the OM API.

The DFSCGxxx parameters can also be specified on the DFSDFxxx member of the IMS PROCLIB data set.

Table 64. Applicability of DFSCGxxx parameters based on resource manager environment

Parameter	RMENV=Y	RMENV=N
ACBSHR	optional	not applicable
CMDSEC	optional	optional
DBQUIESCETO	optional	optional
GBL_SERIAL_PGM	optional	optional
IMSPLEX	required	required
LEOPT	optional	optional
MODBLKS	optional	optional
NORSCCC	ignored	ignored
ODBMSECURE	optional	optional
OLC	optional	optional
OLCSTAT	optional	optional
OMPROC	not applicable	optional
RMENV	optional	required
PLEXPARM	optional	not applicable
SCIPROC	not applicable	optional
UOM	optional	optional

Important: When RMENV=N and OLC=GLOBAL is specified, ensure that no other IMS attempts to use the same OLCSTAT data set. If another IMS uses the same OLCSTAT data set, or if the OLCSTAT data set utility (DFSUOLCO) is used to initialize the data set for another member, an additional IMSID is added to the OLCSTAT data set. If this occurs and IMS (running with RMENV=N and OLC=GLOBAL specified) attempts to initiate an online change by issuing the INIT | TERM OLC command, the command is rejected because an IMSID other than the one executing the command resides in the OLCSTAT data set. The OLCSTAT data set must then be corrected before an INIT | TERM OLC can complete successfully.

Parameters

ACBSHR=

Specifies whether this IMS system shares a common set of application control blocks (ACBs) with other IMS systems in an IMSplex. The ACBSHR= parameter determines whether changes to a set of ACBs must be coordinated across multiple IMS systems.

The shared set of ACBs can be in either ACB libraries or, if the IMS management of ACBs is enabled, a shared IMS catalog.

The ACBSHR parameter can be specified in both the DFSCGxxx member and the COMMON_SERVICE_LAYER section of the DFSDFXxx member in the IMS PROCLIB data set. If ACBSHR is specified in both members, IMS uses the ACBSHR value that is specified in the DFSCGxxx member of the IMS PROCLIB data set.

In an environment that uses ACB libraries, each IMS system that shares an OLCSTAT data set must have the same value for ACBSHR=. If the ACBSHR= values are not the same, the INIT OLC PREPARE TYPE (ACBMBR) command is rejected.

When the IMS management of ACBs is enabled by ACBGMT=CATALOG, the ACBSHR parameter alone determines which IMS systems are included in the global coordination of ACB changes.

ACB changes are activated by the `IMPORT DEFN SOURCE(CATALOG)` command. The Online Change process is not used for ACB changes when `ACBMGMT=CATALOG`.

Y

Specifies that the set of ACBs that is used by this IMS system is shared by other IMS systems. Any changes to the shared set of ACBs must be coordinated among the sharing IMS systems.

If ACB libraries are used and `OLC=GLOBAL`, the global Online Change process requires both the CSL Resource Manager (RM) and an `OLCSTAT` data set to coordinate changes to ACBs among the online IMS systems in the IMSplex.

If the IMS management of ACBs is enabled, RM is required to coordinate ACB changes globally among all online IMS systems that specify `ACBSHR=Y` in an IMSplex. The OLC process is not used, so the `OLC=` parameter and the `OLCSTAT` data set do not apply.

When IMS manages ACBs, the `ACBSHR=` specification of each IMS system in the IMSplex determines whether the IMS system is included in the global coordination of ACB changes.

If `ACBSHR=Y` is specified in the command master when the **IMPORT DEFN SOURCE(CATALOG)** command is issued, the **IMPORT DEFN** command is routed to and processed by all IMS systems in the same IMSplex that also specify `ACBSHR=Y`, even if they are not specified on the `ROUTE` parameter in TSO SPOC. If any systems that specify `ACBSHR=N` other than the command master are specified on the `ROUTE` parameter, those IMS systems also attempt to process the **IMPORT DEFN** command, but processing is asynchronous and succeeds only if those systems have pending ACB changes in a separate IMS catalog.

If `ACBSHR=Y` is specified for IMS systems in a sysplex data sharing environment, you must specify `PDESHARING(EXTENDED)` in the `IGDSMSxx` member of `SYS1.PARMLIB` for each z/OS system in the sysplex.

N

Specifies that this IMS system uses its own dedicated set of ACBs.

If `ACBSHR=N` is specified in the command master when the `IMPORT DEFN SOURCE(CATALOG)` command is issued, the `IMPORT DEFN` command is processed locally only, unless other IMS systems that also specify `ACBSHR=N` are specified on the `ROUTE` parameter in TSO SPOC. If other IMS systems also process the `IMPORT DEFN` command, but they do so asynchronously and only if they have pending ACB changes in their own IMS catalog.

CMDSEC=

Specifies whether IMS should perform security checking on commands that are routed from OM, and if so, whether RACF or the Command Authorization exit routine (or both) should be used. If IMS performs the security checking on commands, the `CMDSEC` keyword also specifies whether RACF, the IMS Command Authorization exit routine (`DFSCCMD0`), or both should be used. This option applies only to IMS type-1 commands that can be issued through the OM API.

For type-2 commands (that are only allowed through the OM API, not allowed from the IMS master terminal), all security checking is performed by OM and is controlled by the `CMDSEC=` parameter on the OM startup JCL or on the OM initialization member of the IMS `PROCLIB` data set (`CSLOIxxx`).

Recommendation: Use OM command security instead of IMS security. By allowing OM to perform the security checks, commands which fail security authorization are not routed to IMS, which reduces processing overhead and network traffic. When IMS command security is used, you must ensure that all IMS systems use the same security profiles and user exits. If IMS systems in the same IMSplex use different security rules, the results of command security checking may be unpredictable.

A

Specifies that both RACF and `DFSCCMD0` are to be called (options E and R). RACF is called first. Then the security authorization facility (SAF) return code, RACF return code, and RACF reason code are passed to `DFSCCMD0`.

E

Specifies that the Command Authorization exit routine is to be called for command authorization.

N

Specifies that no authorization checking is to be done. Security checking can still be performed by OM depending on the specification of the OM CMDSEC= parameter.

R

Specifies that RACF is to be called for command authorization.

DBQUIESCETO=

The amount of time, in seconds, that the **QUIESCE** command waits for currently running applications to commit before the **QUIESCE** command is aborted. This value applies only when the quiesce function is initiated. The actual time required for the **QUIESCE** command varies and might exceed this timeout value. The default value is 30 seconds. sss must be a non-zero value 1 - 999. You can also specify this timeout value in the COMMON_SERVICE_LAYER section of the DFSDFxxx member of the IMS PROCLIB data set, or override the value using the appropriate **UPDATE** command for the resource type, for example, **UPDATE DATAGRP NAME(name) START(QUIESCE) SET(TIMEOUT(10))**.

GBL_SERIAL_PGM=Y | N

Specifies whether (Y) or not (N) the sysplex serial program management feature of IMS is active. The default is Yes.

This parameter can be specified in both the DFSCGxxx and DFSDFxxx members of the IMS PROCLIB data set. If it is specified in both members, IMS uses the GBL_SERIAL_PGM value that is specified in the DFSCGxxx member.

IMSPLEX=

Specifies a one- to five-character identifier. IMS appends this identifier to "CSL" to create the IMSplex group name. All IMSplex members (OM, RM, IMS, CQS) that are in the same IMSplex sharing group sharing either databases or message queues must specify the same identifier. IMS has no way to enforce this; the user is responsible for ensuring that the IMSplex name is correctly specified. The same identifier must also be used for the IMSplex= parameter in the CSLSIxxx, CSLOIxxx, CSLRIxxx, and CQSIPxxx members of the IMS PROCLIB data set.

When RMENV=N, IMSPLEX= specifies a one- to five-character name of the IMSplex that OM, SCI, and the IMS control regions join. This IMSplex is simply a grouping of all address spaces that are managed by one or more OMs.

This parameter is required.

LEOPT=Y | N

Specifies whether IMS should allow IBM Language Environment for z/OS (LE) dynamic runtime parameter overrides.

MODBLKS=

Specifies whether resources in the IMS.MODBLKS data set are defined dynamically or by online change. These resources include databases, programs, routing codes, and transactions. This attribute can only be changed on an IMS cold start. If the value is changed for the next IMS warm or emergency restart, IMS restart terminates, and abend U0168 is issued.

DYN

Enables dynamic definition for resources in the IMS.MODBLKS data set. Resource definitions can be dynamically added, changed, or deleted by using online commands, including CREATE, DELETE, and UPDATE. Online change for resources in the IMS.MODBLKS data set that is initiated by a /MODIFY PREPARE MODBLKS or INITIATE OLC PHASE(PREPARE) TYPE(MODBLKS) command is not allowed.

OLC

Enables online change for resources in the IMS.MODBLKS data set. Resource definitions can be added, changed, or deleted by using online change. Online change commands for resources in the IMS.MODBLKS data set include /MODIFY PREPARE MODBLKS or INITIATE OLC PHASE(PREPARE) TYPE(MODBLKS). When MODBLKS=OLC, UPDATE commands that update runtime values (such as a transaction class) are permitted. This is the default.

ODBMSECURE=

Specifies whether IMS performs security checking on the PSB resource for an ODBM thread at the time of the allocate PSB (APSB) request. The RACF general resource class (RCLASS), AIMS or Axxxxxxx (where xxxxxx is the value specified on the RCLASS= initialization EXEC parameter), is used for PSB resource checking.

Specifying any value other than ODBMSECURE=I overrides the **ISIS=** and **ODBASE=** parameters for APSB requests from an ODBM connector.

I

Ignore. Specifies that the ODBMSECURE= parameter is to be ignored. I is the default.

N

None. Specifies that no security checking is to be performed for APSB requests from an ODBM thread. Specifying ODBMSECURE=N overrides both the **ISIS=** and **ODBASE=** parameters.

A

All. Specifies that both RACF and the IMS RASE user exit routine are to be called (options E and R) for PSB authorization. RACF is called first. The SAF return code and the RACF return and reason codes are passed to the IMS RASE user exit routine.

E

Exit. Specifies that the IMS RASE user exit routine is to be called for PSB authorization.

R

RACF. Specifies that RACF is to be called for PSB authorization by using the AIMS or Axxxxxxx general resource class.

NORSCCC=()

Resource consistency checking is no longer performed for ACBLIB, FMTLIB, and MODBLKS libraries, regardless of whether there is a resource structure or if values are specified on NORSCCC. The NORSCCC keyword is supported for compatibility, but its values are ignored.

Specifies that no resource consistency checking is to be performed for the specified resources. The resources to not check for consistency must be enclosed within parentheses and separated by commas. The NORSCCC keyword must precede the left parenthesis. NORSCCC is an optional parameter.

If a resource structure is defined for the IMSplex, by default, consistency checking is performed for ACBLIB, FORMAT, and MODBLKS. Consistency checking is performed on the data set names; it is not performed on the resources that reside in the libraries. Resource consistency checking is useful for cloned systems that either share all these data sets or use the same data set names on each IMS.

If no resource structure is defined, no resource definition consistency checking is performed.

When RMENV=N, the NORSCCC parameter is ignored.

Specify one or more of the following parameters:

ACBLIB

The ACBLIB data set names are not checked for consistency. The IMS systems in the IMSplex do not need to define the same data sets for the ACBLIB library. ACBLIB applies only if OLC=GLOBAL is specified.

FORMAT

The FORMAT data set names are not checked for consistency. The IMS systems in the IMSplex do not need to define the same data sets for the FORMAT library. FORMAT applies only if OLC=GLOBAL is specified.

MODBLKS

The MODBLKS data set names are not checked for consistency. The IMS systems in the IMSplex do not need to define the same data sets for the MODBLKS library. MODBLKS applies only if OLC=GLOBAL is specified.

OLC=LOCAL | GLOBAL

Specifies the scope of the online change. OLC=LOCAL means that the online change applies locally to each IMS. Local online change is prepared and committed by using the /MODIFY PREPARE and /MODIFY COMMIT commands on each local IMS. The local online changes must be manually coordinated across an IMSplex. OLC=GLOBAL means that the online change is coordinated across the IMSplex; ACBLIB member OLC requires OLC=GLOBAL. Global online change is prepared and committed by using the INITIATE OLC command. If global online change is enabled and a resource structure is defined, the MODBLKS, FORMAT, and ACBLIB data sets must be consistent across the IMSplex, unless resource consistency checking is omitted by the NORSCCC keyword.

When the IMS management of ACBs is enabled, the OLC parameter does not apply to changes made to ACBs. Instead, the value of the ACBSHR= parameter determines whether IMS activates ACBs only locally or coordinates the activation globally when the **IMPORT DEFN SOURCE (CATALOG)** command is issued.

OLCSTAT=

Specifies the 1 - 44 character data set name of the OLCSTAT data set. OLCSTAT is ignored if OLC=LOCAL is specified. OLCSTAT is required if OLC=GLOBAL is defined. The OLCSTAT data set is a cataloged BSAM data set that contains global online change information and status. The data set name is used to dynamically allocate the data set when an IMS initialized, restarts, or is master of an online change phase.

All IMS systems in an IMSplex must refer to the same physical OLCSTAT data set. If a resource structure is defined to the IMSplex, IMS ensures that the OLCSTAT data set name is defined consistently for the IMSplex. If the OLCSTAT data set name definition is not consistent with the OLCSTAT defined to other IMS systems in the IMSplex, IMS initialization fails.

When the IMS management of ACBs is enabled, the OLCSTAT parameter does not apply to the activation of new or modified ACBs in online IMS systems.

RMENV=Y | N

Indicates whether (Y) or not (N) IMS requires an RM environment.

Y

Indicates that IMS requires an RM environment in order to use Resource Manager services. IMS initialization does not complete until IMS successfully registers with RM. This is the default.

N

Indicates that IMS does not require an RM environment and does not use Resource Manager services. IMS does not attempt to register with RM even if an RM address space is active. When RMENV=N, you do not need to define or start an RM address space. IMS commands and functions that require RM are not available in this environment.

When the IMS management of ACBs is enabled, a specification of RMENV=N limits the activation of ACB changes to the local IMS system. If the ACBs are shared by other IMS systems, as indicated by ACBSHR=Y, you must coordinate the activation of ACBs in the other systems separately.

When RMENV=N, online change is as follows:

- If OLC=LOCAL, use the /MODIFY command to initiate online change. The MODSTAT data set must be defined.
- If OLC=GLOBAL, use the INIT OLC command to initiate online change. The OLCSTAT data set must be defined; however, it cannot be shared between IMS systems.

You can change the value of RMENV= across IMS warm or cold starts.

RMPROC=

Specifies the one- to eight-character name of the member of the IMS PROCLIB data set that contains the procedure for the RM address space. This parameter is optional.

IMS does not start the RM address space specified by this parameter if another RM address space is already active in the IMSplex during IMS initialization.

If RMPROC= is not specified, start the RM address space before starting IMS. This start sequence can be performed through an automation program or by another IMS control region.

OMPROC=

Specifies the one- to eight-character name of the member of the IMS PROCLIB data set that contains the procedure for the OM address space. This parameter is optional.

IMS does not start the OM address space specified by this parameter if another OM address space is already active in the IMSplex during IMS initialization.

If OMPROC= is not specified, start the OM address space before starting IMS. This start sequence can be performed through an automation program or by another IMS control region.

PLEXPARAM=()

PLEXPARAM is optional. If you do not specify it, either the default value or a NULL value is used. Refer to the specific subparameter to determine whether the default or NULL value is used.

The PLEXPARAM parameter defines how global status is maintained for resources in an IMSplex. An IMS system that is initialized in an IMSplex checks to see if a global PLEXPARAM entry exists in the RM resource structure. If the entry exists, the IMS system uses the values. If no entry exists, the initializing IMS writes its resource definition values to the RM resource structure global PLEXPARAM entry. Any IMS system that initializes in that IMSplex after that uses the values stored by the first IMS system. If the subsequent IMS system has PLEXPARAM values that are different from the values in the global PLEXPARAM entry, message DFS3425I is issued, and values from the global PLEXPARAM entry are used.

To view the current PLEXPARAM values, use the QUERY IMS command. To update PLEXPARAM values, use the UPDATE IMS command.

If an IMS system is running in an IMSplex that does not include an RM, or the RM in the IMSplex does not use a resource structure, the PLEXPARAM parameter is ignored. No message is issued indicating that the parameter is ignored. All PLEXPARAM values are set to no (N).

In an FDBR system, the PLEXPARAM parameter is ignored. No message is issued indicating that the parameter is ignored. All PLEXPARAM values are set to no (N). However, an FDBR system and an XRF alternate system do maintain global PLEXPARAM values internally. You can use the QUERY IMS SHOW(PLEXPARAM) command to display PLEXPARAM values in an FDBR or XRF alternate system.

GSTSDB=

Specifies how global status for databases is kept in the IMSplex.

N

No global status is maintained for databases resources in the RM. This is the default value for DB/DC and DBCTL regions.

Y

Global status for databases is maintained in the RM.

null

No global status is maintained for databases resources in the RM. This is the default value for DCCTL regions.

A DCCTL system that initializes this value in the global PLEXPARAM entry writes a null value. If a DB/DC or DBCTL system later joins that IMSplex, that system updates the GSTSDB value in the global PLEXPARAM entry with the value from its PLEXPARAM initialization parameter.

GSTSAREA=

Specifies how global status for DEDB areas is kept in the IMSplex.

N

No global status is maintained for DEDB area resources in the RM. This is the default value for DB/DC and DBCTL regions.

Y

Global status for DEDB areas is maintained in the RM.

null

No global status is maintained for DEDB area resources in the RM. This is the default value for DCCTL regions.

A DCCTL system that initializes this value in the global PLEXPARM entry writes a null value. If a DB/DC or DBCTL system later joins that IMSplex, that system updates the GSTSDB value in the global PLEXPARM entry with the value from its PLEXPARM initialization parameter.

GSTSTRAN=

Specifies how global status for transactions is kept in the IMSplex.

N

No global status is maintained for transaction resources in the RM. This is the default value for DB/DC and DCCTL regions.

Y

Global status for transactions is maintained in the RM.

null

No global status is maintained for transaction resources in the RM. This is the default value for DBCTL regions.

A DBCTL system that initializes this value in the global PLEXPARM entry writes a null value. If a DB/DC or DCCTL system later joins that IMSplex, that system updates the GSTSDB value in the global PLEXPARM entry with the value from its PLEXPARM initialization parameter.

SCIPROC=

Specifies the one- to eight-character name of the member of the IMS PROCLIB data set that contains the procedure for the SCI address space. This parameter is optional.

If SCIPROC= is not specified, start the SCI address space before starting IMS. This start sequence can be performed through an automation program or by another IMS control region.

UOM=

Specifies which unsolicited output messages are sent to the Operations Manager:

MTO

Send only unsolicited output messages that are destined for the MTO, unsolicited output messages that are destined for the system console, or both, to OM. This is the default.

NONE

Do not send any unsolicited output messages to OM.

ALL

Send all unsolicited output messages to OM.

Related concepts

[“IMS Syntax Checker” on page 381](#)

The Syntax Checker is an ISPF application that helps you define, verify, and validate parameters and their values in the members of the IMS PROCLIB data set. Use the IMS Syntax Checker to avoid typographical and syntactical errors when modifying the parameter values for the IMS PROCLIB data set members.

Related reference

[“CSLOIxxx member of the IMS PROCLIB data set” on page 714](#)

Use the CSLOIxxx member of the IMS PROCLIB data set to specify parameters that initialize the Operations Manager (OM) address space.

[Command Authorization exit routine \(DFSCCMD0\) \(Exit Routines\)](#)

DFSDCxxx member of the IMS PROCLIB data set

Use the DFSDCxxx member of the IMS PROCLIB data set to define data communication options.

You can find an example of the DFSDCxxx member of the IMS PROCLIB data set, DFSDC000, in library SDFSSLIB.

The DC= parameter in the IMS or DCC startup procedure defines the DFSDCxxx PROCLIB member that is used. The default suffix is 000.

Environments

The DFSDCxxx member of the IMS PROCLIB data set applies to the DB/DC and DCCTL environments.

Syntax

You can use the IMS Syntax Checker to modify this member of the IMS PROCLIB data set.

If you use the DFSDCxxx member to override the master or secondary master node names, do not specify a statically defined node name.

If you use the DFSDCxxx member to override the master or secondary master LTERM names, do not specify a statically defined LTERM name.

If you use the DFSDCxxx member to override the generic LTERM name of the master LTERM or secondary master LTERM, do not specify a statically defined LTERM name.

The node that you specify using the PMTO or SMTO parameters must have the same physical characteristics as the default node that you are overriding. For example, you cannot override a SLU2 device with a non-SNA device.

If you change the PMTO=, SMTO=, PMOTn=, or SMTON= control statements in the DFSDCxxx member, you must perform a cold start of IMS. You can perform a warm start for changes to any other control statements in the DFSDCxxx member.

Usage

A DFSDCxxx member consists of one or more 80-character records. You code keyword parameters in positions 1-71. Positions 72-80 are ignored. Keywords can contain leading and trailing blanks. If you specify multiple keywords in a record, use commas as delimiters.

Parameters

AOS=

AOS=N

Specifies that shared message queue support for synchronous APPC/OTMA is not active. The default is inactive (N).

AOS=Y

Specifies that shared message queue support for synchronous APPC/OTMA is active (Y). Shared message queue (SMQ) support for APPC/OTMA enables IMSplex users to execute transactions that are originated by APPC or OTMA on a back-end system.

If AOS=Y, transactions with SYNCLVL=SYNCPT are processed with RRS as the synchronization point manager.

AOS=F

Activates the function by force (F) even if another member in the IMSplex cannot activate the function.

APPC/OTMA SMQ enablement uses z/OS Resource Recovery Services (RRS) multiSystem cascaded transactions to synchronize IMS systems. If RRS is not active on one system, the systems that have specified F (force) still queue incoming transactions without any affinity. Therefore, if a system without RRS tries to process one of these transactions, IMS abends the application with a U711 code.

AOS=B

Specifies that APPC and OTMA use z/OS cross-system coupling facility (XCF) to communicate between the front-end and the back-end systems for synchronous transactions with sync level of NONE and CONFIRM.

If RRS=Y, transactions with synchronization level of NONE or CONFIRM are processed at the back end using XCF communication. Transactions with sync level of SYNCPT are processed at either the front-end or back-end systems, using RRS.

If the back-end system has RRS=N, transactions with synchronization level of NONE or CONFIRM are processed at the back end using XCF communication. Transactions with sync level of SYNCPT are processed only at the front-end system. However, if the front-end system also has RRS=N, transactions with sync level of SYNCPT are not processed at all.

AOS=B requires a MINVERS value that is set to 12.1 or later.

AOS=S

Specifies that APPC and OTMA use XCF to communicate between the front-end and the back-end systems for synchronous transactions with sync level of NONE and CONFIRM and RRS multiSystem cascaded transactions for synchronous transaction with sync level of SYNCPT.

For synchronous transaction with sync level of SYNCPT, the functionality of AOS=S is equivalent to the AOS=F specification, meaning that if RRS is not active on one system, the systems that have specified S (force) still queue incoming transactions globally without any affinity. If a system without RRS tries to process one of these transactions, IMS abends the application with a U711 code.

The back end starts either the new XCF message processing or the existing RRS message processing depending on whether the message has the XCF indicator or the RRS indicator.

AOS=S requires a MINVERS value that is set to 12.1 or later.

AOS=X

Specifies that APPC and OTMA use XCF to communicate between the front-end and the back-end systems for synchronous transactions with sync level of NONE and CONFIRM.

RRS is not used for synchronous transactions with sync level of SYNCPT. In this case, specifying AOS=X is equivalent to specifying AOS=N.

The X parameter is applicable only to the front-end system. The back-end system is not required to specify this parameter.

The back end starts either the new XCF message processing or the existing RRS message processing depending on whether the message has the XCF indicator or the RRS indicator.

AOS=X requires a MINVERS value that is set to 12.1 or later.

Important: By default, APPC/OTMA shared message queue support is deactivated for all the members within the IMSplex, except for members where the F (force) option is specified.

AOSLOG=

Specifies for APPC and OTMA whether (Y) or not (N) the front-end system writes an X'6701' log record for the following cases:

- Response message returned from the back-end system by XCF for transactions with synchronization levels of NONE, CONFIRM, and SYNCPT.
- Error message returned from the back-end system by XCF for transactions with all synchronization levels of NONE, CONFIRM, and SYNCPT.

AOSLOG=Y

Indicates that the front-end system logs the X'6701' record.

AOSLOG=N

Indicates that the front-end system does not log any X'6701' record. AOSLOG=N is the default value.

The AOSLOG parameter is applicable only to the front-end system. The back-end system is not required to specify this parameter.

APPCASY=

Specifies whether (Y) or not (N) a non-response transaction originating from a program-to-program switch should be scheduled asynchronously or synchronously (S). In a shared-queues environment, the originated transactions usually maintain affinity with the system in which the originating transaction was processed, unless APPCASYS is set to S (and AOS=Y).

If you specify APPCASYS=S, the first program-to-program switch that can continue the synchronous conversation is synchronous. Every further program switch is asynchronous.

If you specify APPCASYS=S, the OTMAASY value is S. If you specify OTMAASY=S, the APPCASYS value is S.

In a shared-queues environment where the support for synchronous APPC/OTMA is active (AOS=Y), if you specify APPCASYS=S, the program-to-program switch transactions do not have any affinity.

The default is APPCASYS=Y.

Asynchronous transactions have no affinity.

Recommendation: Use the default specification of APPCASYS=Y.

Restriction: This parameter applies to synchronous transactions only.

APPCIOT=(*mmmm:ss,mmmm*)

Specifies the APPC timeout values in minutes and seconds. Valid values for *mmmm* are 00 to 1440. Valid values for *ss* are 00 to 59. If APPCIOT=00, there is no timeout detection.

The first parameter specifies the APPC/MVS timeout value. This is the number of minutes or seconds an APPC/MVS service is allowed to wait for completion.

The second parameter specifies the APPC/IMS timeout expression. This is the number of minutes an application is allowed to be inactive and is for synchronous conversations only. Inactive means that the application was not able to respond within the timeout limit.

Note: In some cases, IMS cannot determine if an APPC conversation is synchronous or asynchronous. This situation occurs in program-to-program switches, where IMS cannot predict which program continues the synchronous APPC conversation.

Requirement: Changing this parameter after a previous IMS start does not require a cold start. You must restart IMS, however, to allow the new specification to take effect.

APPCLU=

Identifies a local LU to be used for outbound message processing.

N

The base LU is used for asynchronous message responses to the IOPCB. This is the default.

Y

The incoming local LU is used as the local LU for asynchronous message responses to the IOPCB.

APPCMAXC=(*31_bit_max,64_bit_max*)

Defines the flood control thresholds for APPC/IMS transaction requests.

The APPCMAXC parameter accepts the following positional values:

31_bit_max

Defines the maximum number of active APPC/IMS conversations that IMS can process concurrently before either subsequent incoming transaction requests are queued in 64-bit storage or, if the queuing of APPC transaction requests in 64-bit storage is disabled, IMS stops all input from APPC/MVS.

IMS commands that are submitted via APPC and APPC requests that are received by a back-end IMS system in a shared queues environment are never queued to 64-bit storage.

Messages queued in 64-bit storage are not acknowledged as received by IMS until IMS accepts them for processing.

Valid values are 20 - 30000 and 0. The default value is 5000.

A specification of 0 disables APPC/IMS flood control.

64_bit_max

Defines the maximum number of incoming APPC/IMS requests that can be queued in 64-bit storage before IMS stops all input from APPC/zOS.

Messages that are already queued in 64-bit storage when APPC input is stopped remain on the queue until IMS retrieves them for processing. IMS resumes the queuing of incoming APPC/IMS requests in 64-bit storage after the number of queued requests drops below 50% of the rejection threshold.

Valid values are 1- 9,999,999 and 0. The default value is 10,000.

A specification of 0 disables the queuing of APPC requests in 64-bit storage. When 64-bit queuing is disabled, if a flood condition occurs, the 31-bit maximum defines the threshold at which IMS stops all APPC input.

For more information about APPC/IMS flood control, see [APPC/IMS flood control \(Communications and Connections\)](#).

APPCRCV=

Specifies whether IMS should pass the first segment to the DFSNPTR0 or DFSMSCE0 exit. The default is Y. If N is specified, IMS calls the exits before receiving the first segment.

ASSNCHANGE=NOSAVE | SAVE

Sets the default value for the /ASSIGN LTERM|USER TO USER command. SAVE specifies that LTERM assignments (made in ETO) are retained across session and IMS restarts (the user and LTERM control blocks are not deleted). The default is NOSAVE, which indicates that the assignment is not retained and the user and LTERM control blocks are deleted.

You can override the ASSNCHANGE control statement by specifying SAVE or NOSAVE on the /ASSIGN command. If you issue the /ASSIGN command without specifying SAVE or NOSAVE, IMS uses the default value that is specified on the ASSNCHANGE control statement.

Requirement: Changing this parameter after a previous IMS start does not require a cold start. You must perform a warm start, however, to allow the new specification to take effect.

AUTHLOG=ALL | NOMSG | NONE

Determines whether to suppress a RACF ICH408I message to the system console, and whether to turn on SMF logging. This determination takes place after an AUTH call issued by an IMS application program fails authorization.

ALL

IMS turns on SMF logging, and the RACF ICH408I message is issued. ALL is the default.

NOMSG

IMS turns on SMF logging when appropriate, and the RACF ICH408I message is suppressed.

NONE

SMF logging is not turned on, and the RACF ICH408I message is suppressed.

AUTLCHANGE= NOSAVE | SAVE

Sets the default value for the /CHANGE USER AUTOLOGON command. SAVE specifies that autologon changes made in ETO are retained across session and IMS restarts (the user control block are not deleted and remain in effect across a restart or XRF takeover until another /CHANGE command with the NOSAVE parameter is issued). The default is NOSAVE, which indicates that the autologon changes are not retained across session and IMS restarts (the user control block is deleted).

You can override the AUTLCHANGE control statement by specifying SAVE or NOSAVE on the /CHANGE command. If you issue the /CHANGE command without specifying SAVE or NOSAVE, IMS uses the default value that is specified on the ASSNCHANGE control statement.

Requirement: Changing this parameter after a previous IMS start does not require a cold start. You must perform a warm start, however, to allow the new specification to take effect.

BMPUSID=PSBNAME | USERID

Specifies the system option for the value to be placed in the user ID field of the message prefix for a message generated by a non-message driven BMP and the value to be used for the userid for CHNG and AUTH calls made by a non-message-driven BMP.

- If BMPUSID=USERID is specified, the value from the USER= keyword on the JOB statement is used.
- If USER= is not specified on the JOB statement, the program's PSB name is used.
- If BMPUSID=PSBNAME is specified, or if BMPUSID= is not specified at all, the program's PSB name is used. If PSBNAME is not defined to RACF, the Userid of the current Address Space will be used; this will be the Home Dependent Region one, or the Control Region one if LSO=Y or if PARDLI=1 has been specified for the BMP. Userid of the current Address Space will be used also if DFSBSEX0 has returned RC08.

Note: This parameter is not valid for DBCTL. The value from the USER= keyword on the JOB statement is used for a JBP.

Requirement: Changing this parameter after a previous IMS start does not require a cold start. You must perform a warm start, however, to enable the new specification to take effect.

ERPKPSES=

Specifies whether or not IMS keeps the ISC VTAM session open after an error recovery procedure (ERP) message is received from the partner subsystem with sender ERP sense code X'08460000'. Depending on the bracket protocols that were used in the ISC output message in error, ERPKPSES also determines whether the ERP message is passed to the master terminal operator (MTO) or to the original inputting terminal.

N

Upon receiving an ERP message, IMS terminates the ISC VTAM session, keeps the original message on the queue, and passes the ERP message to the master terminal operator (MTO). ERPKPSES=N is the default.

Y

Upon receiving an ERP message, IMS keeps the ISC VTAM session open, dequeues the original message, and passes the ERP message to either the MTO or the original input terminal, depending on the bracket protocols that were used in the original message.

GENIMSID=

A 1- to 8-character alphanumeric shared IMS ID that identifies a TCP/IP generic resources group in an IMSplex.

The GENIMSID= parameter can be specified in either the DFSDCxxx PROCLIB member or in the MSC section of the DFSDFxxx PROCLIB member. Specifications in the DFSDCxxx PROCLIB member override specifications made in the DFSDFxxx PROCLIB member.

Each MSC-enabled IMS system in the IMSplex that participates in the TCP/IP generic resources group must specify the same shared IMS ID on the GENIMSID parameter.

The IMS Connect instance that supports TCP/IP generic resources group in the IMSplex must also specify the shared IMS ID on the GENIMSID parameter of the IMS Connect MSC configuration statement for each participating IMS system.

MSC-enabled IMS systems outside of the IMSplex connect to the IMSplex by specifying the shared IMS ID. The shared IMS ID is specified on the NAME parameter of the definition of the MSC physical link (MSPLINK) that defines a TCP/IP-type MSC physical link to the IMSplex. The IMS systems outside of the IMSplex do not need to define a MSC links to specific IMS systems in the IMSplex.

New connections to the TCP/IP generic resources group are accepted by the first IMS system to respond to the connection request when it is passed to the IMSplex by IMS Connect. After the connection has been accepted by a participating IMS system, the MSC physical link and all logical links assigned to it have affinity with that IMS system until the link is terminated.

The IMS ID must begin with an alphabetic character.

The value of GENIMSID cannot be the same as the IMS ID of any IMS system in the IMSplex or of any remote IMS system that connects to the IMSplex by using an MSC TCP/IP link.

GRAFFIN=IMS | VTAM

This keyword is obsolete and is ignored.

GRESTAE=Y | N

Specifies whether IMS should bypass the VTAM generic resource logic in the IMS ESTAE exit.

Y indicates that IMS should continue the existing ESTAE logic to delete affinity for all nodes where no status remains before closing the ACF/VTAM ACB.

N indicates that IMS should close the ACF/VTAM ACB immediately to expedite IMS termination, and leave affinity for all nodes set.

Requirement: Changing this parameter after a previous IMS start does not require a cold start. You must perform a warm start, however, to allow the new specification to take effect.

GRMESTAE=Y | N

Indicates whether MSC link affinity should be deleted.

Y

During an IMS abend, IMS calls the ESTAE routine in the control region and deletes the affinity setting of any MSC link that does not have a significant status requiring the link session to connect to the same IMS in the IMSplex. This is the default.

N

IMS does not delete MSC link affinity in the ESTAE routine.

Significant status for MSC means that the link is in ERE mode. Use the /DIS LINK command to display status.

IMSWT=IMSWT | nnnnn

Specifies up to 5 characters that are appended with a 3-character line number yyy to make up the full JOBNAME (nnnnnyyy) in the /STA REGION jobname for the auto-scheduled spool print utility. If IMSWT= is not specified or if nnnnn is blank, IMS uses the default value of IMSWT (IMSWTyyy).

Requirement: Changing this parameter after a previous IMS start requires a cold start to take effect.

ISCTCPIP=(nodename,iconname)

Sets a static LU 6.1 ISC terminal to use TCP/IP communication protocols.

The *nodename* value is the name of an LU 6.1 ISC terminal, as specified on the NAME parameter of the TERMINAL macro that is part of the terminal system definition.

The *iconname* value is the IMSplex name of a local IMS Connect instance that manages TCP/IP communications for this IMS. The *iconname* value must match the name specified on the MEMBER parameter of either the ISC statement or the IMSplex statement in the IMS Connect configuration PROCLIB member (HWSCFGxx). The name specified in the *iconname* position must start with an alphabetic character and can be 1- to 8-alphanumeric characters long.

LU 6.1 terminals are the only static ISC terminals that support TCP/IP. Terminals are defined as LU 6.1 during stage 1 system definition by UNITYPE=LUTYPE6 on the TYPE macro. If the terminal referenced by the *nodename* value is not LU 6.1, an error message is issued and the non-LU 6.1 terminal is unchanged.

The *nodename* value must be unique among all node names specified on ISCTCPIP keywords in the DFSDCxxx member. If the node name is not unique, each subsequent specification of the node name is rejected and an error message is issued.

Requirement: After IMS is started, any changes to this parameter require a cold start before they can take effect.

TCP/IP support for ISC is provided by IMS Connect. If you are setting up ISC TCP/IP support for the first time, you must also code the appropriate configuration statements in the IMS Connect PROCLIB member, including the ISC and RMTICIS statements.

LOCKSEC=Y | N

When password protection is used for the /LOCK and /UNLOCK commands, specifies whether (Y) or not (N) calls to RACF security and the Transaction Authorization exit routine (DFSCTRNO) are made. When LOCKSEC=Y is specified, the command is processed if either of the following is true:

- The resource specified by the command is defined to RACF and the user is authorized to use the resource.
- The resource is not defined to RACF.

If the resource is defined to RACF, but the user is not authorized to use the resource, the command is rejected with the message DFS3689W.

MFSPFV=N | Y**N**

The Message Format Service (MFS) function does not check the content of a protected field that is returned from a 3270 or SLU2 device.

Y

The MFS function checks the content of a protected field that is returned from a 3270 or SLU2 device. If the MFS detects that protected data in the input is altered from the content that was transmitted to the device, it ignores the input with message DFS573.

MSCSEC=

Specifies the security options for direct and non-direct routed transactions received from an MSC link.

The MSCSEC= parameter can be specified in either the DFSDCxxx PROCLIB member or in the MSC section of the DFSDFxxx PROCLIB member. Specifications in the DFSDCxxx PROCLIB member override specifications made in the DFSDFxxx PROCLIB member.

LRDIRECT

Specifies that Link Receive routing use RACF, the Transaction Authorization exit routine (DFSCTRNO), or both to check security for direct routed transactions. This is the default.

LRNONDR

Specifies that Link Receive routing use RACF, the Transaction Authorization exit routine (DFSCTRNO), or both to check security for non-direct routed transactions. No security checking is performed for direct routed transactions.

LRALL

Specifies that Link Receive routing use RACF, the Transaction Authorization exit routine (DFSCTRNO), or both to check security for direct and non-direct routed transactions.

LRNONE

Specifies that the IMS subsystem does not request any security checking for either type of transaction.

CTL

Specifies that RACF security is to authorize the use of the transaction based upon the user ID of the IMS control region.

MSN

Specifies that RACF security is to authorize the use of the transaction based upon the user ID of the MSNAME.

USR

Specifies that RACF security is to authorize the use of the transaction based upon the user ID of the inputting terminal.

EXIT

Specifies that authorization is performed by the Transaction Authorization exit routine (DFSCTRNO).

CTLEXIT

Specifies that both RACF security and the Transaction Authorization exit routine (DFSCTRNO) are used to authorize the IMS control region user ID to use the transaction.

MSNEXIT

Specifies that both RACF security and the Transaction Authorization exit routine (DFSCTRNO) are used to authorize the MSNAME to use the transaction.

USREXIT

Specifies that both RACF security and the Transaction Authorization exit routine (DFSCTRNO) are used to authorize the user ID of the inputting terminal to use the transaction.

NONE

Specifies that no security authorization checking is performed.

MSCVGR=N | Y

Specifies whether MSC links use the GRSNAME or the APPLID name in an IMS VGR environment.

The MSCVGR= parameter can be specified in either the DFSDCxxx PROCLIB member or in the MSC section of the DFSDFxxx PROCLIB member. Specifications in the DFSDCxxx PROCLIB member override specifications made in the DFSDFxxx PROCLIB member.

Y

IMS attempts to use the GRSNAME first to establish the session with the remote IMS. The remote IMS must use the value of the MSPLINK NAME=nodename for the IMSplex GRSNAME.

N

The APPLID name, not the GRSNAME, is used in an IMS VGR environment. This is true also if the remote IMS uses the IMSplex nodename. This is the default.

MFSPDEF=N | Y

Specifies which default Message Format Service (MFS) formats IMS chooses when it issues the DFS3649A and DFS3656A sign-on messages.

Regardless of which option is specified, the Greeting Messages exit routine (DFSGMSG0) can be coded to override the default MOD name chosen by IMS.

N

By default, IMS uses the default MFS formats for passwords when the passwords are entered from the DFS3649A and DFS3656A message panels. The default formats support passwords less than or equal to 8 characters in length.

When **MFSPDEF=N** is specified and a password is specified in the DFS3649A panel, the **/SIGN ON** command is submitted to the IMS system as input.

The following default MOD names are used for passwords that are less than or equal to 8 characters:

DFSIGNP

DFS3649A for dynamic terminals

DFSIGNPB

DFS3649A for static terminals

DFSVERO

DFS3656A

Y

By default, IMS uses the default MFS formats for password phrases when the phrases are entered from the DFS3649A and DFS3656A message panels. The default formats support both password phrases that are up to 100 characters in length and passwords less than or equal to 8 characters in length.

When **MFSPDEF=Y** is specified and a password phrase is specified in the DFS3649A panel, the **/SIGN PASSPHRASE** command is submitted to the IMS system as input.

IMS supports password phrases up to 100 characters in length, but the default MFS formats support the following maximum lengths:

- Fifty character phrases for screen sizes with at least 66 columns
- Twenty-four character phrases for screen sizes fewer than 66 columns

The IMS-provided MFS formats can be modified to increase or decrease the maximum password phrase length as needed.

Alternatively, the **/SIGN PASSPHRASE** or **/SIGN PASSPHRASEQ** command can be used to provide password phrases with lengths up to 100 characters.

The following default MOD names are used for passwords phrases:

DFSIGNPC

DFS3649A for dynamic terminals

DFSIGNPD

DFS3649A for static terminals

DFSVEROA

DFS3656A

MTOMSG=LOCAL|SHRQUE

Specifies whether the IMS system places messages that are destined to the primary master terminal (PMTO) and the secondary master terminal (SMTO) to the shared queues (SQ).

The **MTOMSG** parameter can only be specified in a SQ system and when extended recovery facility (XRF) is not enabled. If this parameter is specified incorrectly, the IMS system takes the following actions:

- If the **MTOMSG** parameter is specified incorrectly, a DFS1920I message is issued. The IMS system uses the appropriate default value for this parameter.
- If the **MTOMSG** parameter is specified in a non-SQ system or a SQ system where XRF is enabled, a DFS1920I message is issued. IMS restart continues.

Exception: The **MTOMSG** parameter does not apply to either message switches or transaction responses. These messages are recoverable because they are always placed in SQ.

LOCAL

This option tells the IMS system to place messages that are destined to PMTO/SMTO on default queues:

- For messages to PMTO, they are placed on local queues.
- For messages to SMTO, they are placed on local queues and locked queues, or SQ in some cases.

This option is the default value.



Attention: The storage of the IMS system might be ran out if you do not dequeue the messages.

SHRQUE

This option tells the IMS system to place messages that are destined to PMTO/SMTO on SQ. In this case, the messages are recoverable.

MTOUSID=

Specifies a user ID that IMS uses if the primary MTO does not sign on for transaction authorization checking.

If you do not specify MTOUSID, the control region's user ID is used for any other terminal that does not sign on.

OUTBND=

Specifies a different outbound LU. The specified LU must be one of the APPC LUs defined in the APPCPMxx member of the SYS1.PARMLIB library. The default outbound LU is BASE LU.

PMTO=name1 | (name1) | (name1,name2)

name1 specifies the node name of the primary master terminal (PMTO). This name overrides the PMTO node name that is specified during IMS system definition.

name2 specifies the name of the additional PMTO resource that exists in an XRF environment. If *name2* is specified in a non-XRF environment, it is ignored.

If the PMTO parameter is not specified, the default PMTO name (either one or both) that was specified during IMS system definition is used.

Requirement: Changing this parameter after a previous IMS start requires a cold start to take effect.

PMTO1-8=name | (name) | (name,MASTER)

Specifies the first through the eighth LTERM names of the PMTO. The names you specify here override the first through the eighth LTERM names specified during IMS system definition. The LTERM name specified with the MASTER designation becomes the PMTO LTERM. These LTERM names must be unique for each IMS system within a shared IMS environment.

Requirement: Changing this parameter after a previous IMS start requires a cold start to take effect.

PMTOG=DFSPMTO | name

Specifies the generic LTERM name of the PMTO. The default is DFSPMTO. Use the same generic LTERM name for each IMS system within a shared IMS environment.

Requirement: Changing this parameter after a previous IMS start requires a cold start to take effect.

PSTIMER=3600 | xxxxx

When Rapid Network Reconnect (RNR) is used, the PSTIMER= parameter specifies a one- to five-digit number indicating the number of seconds IMS can wait pending recovery for persistent sessions following an IMS or ACF/VTAM failure. The restarted IMS must successfully issue an OPEN ACB before the timer expires or the sessions are terminated. Valid values are from zero (no timer) to 86,400[®] seconds (24 hours). The IMS default is 3600 seconds (1 hour). If a null or invalid value is specified, IMS uses 3600.

When an ACB name is specified on the MNPS= keyword (in the PROCLIB member DFSHSBxx or DFSPBxxx, or in the IMS procedure), specifies the amount of time before the XRF alternate must successfully open the MNPS ACB. This applies to an XRF takeover only. It does not apply to an emergency restart because persistent sessions are not restored following a restart in an XRF system using MNPS.

Requirement: Changing this parameter after a previous IMS start does not require a cold start. You must perform a warm start, however, to allow the new specification to take effect.

RACFMSG= N | Y

Determines whether IMS passes RACF sign-on messages to the Greeting Message exit routine (DFSGMSG0) when a user successfully signs on to IMS.

N

IMS does not pass RACF sign-on messages to the DFSGMSG0 user exit routine. This is the default value.

Y

When a user successfully signs on to IMS, IMS passes RACF sign-on messages, such as ICH70001 and ICH70002, to the DFSGMSG0 user exit routine.

RCLASS=

Specifies a 1- to 7-character alphanumeric subsystem identifier for the RACF resource classes for this IMS subsystem. Use the RCLASS= parameter to uniquely identify the resource classes for this IMS subsystem in RACF.

RACF appends the subsystem identifier to a resource class identifier to create the full name of each IMS resource class in RACF. For example, if you specify RCLASS=IMS123, the name in RACF of the IMS transaction authorization resource class for this subsystem would be "TIMS123", because the resource class identifier for IMS transaction authorization is "T". And the name of the IMS command authorization resource class for this IMS subsystem would be "CIMS123".

Defining different subsystem identifiers can be useful for restricting access to resources in one subsystem, while allowing access to those same resources in another. For example, if a production subsystem has a subsystem identifier of IMSPROD and a test subsystem has a subsystem identifier of IMSTEST, an application programmer could then be authorized to TRAN01 in the TIMSTEST transaction authorization resource class, but not to TRAN01 in the TIMSPROD transaction authorization resource class.

The RCLASS= specification in the DFSPBxxx PROCLIB member overrides the RCLASS= specification in the DFSDCxxx PROCLIB member.

RACF uses "IMS" as the default subsystem identifier for IMS subsystems.

RCVYCONV=

Specifies whether the status of a conversation can be recovered (YES) or not (NO). RCVYCONV applies to conversation status, not to output messages. Even if the conversation status is not recovered, conversation output continues to be recoverable and is delivered asynchronously.

The following table describes the default values for RCVYCONV as they relate to the values specified on the SRMDEF keyword.

Table 65. RCVYCONV values related to SRMDEF values

SRMDEF value	RCVYCONV=YES	RCVYCONV=NO
SRMDEF=GLOBAL	Valid (default)	Valid
SRMDEF=LOCAL	Valid (default)	Valid
SRMDEF=NONE	Invalid	Valid (default)

If RCVYCONV is specified incorrectly, message DFS1920I is issued and IMS uses the appropriate default from [Table 65 on page 749](#).

Important: If **STATICOUTSEC=ALL** or **STATICOUTSEC=SREQ** is specified, **RCVYCONV=NO** will apply to static terminals that are affected by the **STATICOUTSEC** parameter. This means that **RCVYCONV=YES** will apply only to dynamic terminals and static terminals that are not affected by the **STATICOUTSEC** parameter. You could refer to the **STATICOUTSEC** parameter description in this topic.

RCVYFP=

Specifies whether the status of Fast Path can be recovered (YES) or not (NO). RCVYFP applies to Fast Path status and output.

The following table describes the default values for RCVYFP as they relate to the values specified on the SRMDEF keyword.

Table 66. RCVYFP values related to SRMDEF values

SRMDEF value	RCVYFP=YES	RCVYFP=NO
SRMDEF=GLOBAL	Valid (default)	Valid
SRMDEF=LOCAL	Valid (default)	Valid
SRMDEF=NONE	Invalid	Valid (default)

Restrictions: If SRMDEF=LOCAL, STSN recoverability (RCVYSTSN) and fast path recoverability (RCVYFP) must be the same. They must both specify YES or both specify NO.

If RCVYFP is specified incorrectly, message DFS1920I is issued and IMS uses the appropriate default from [Table 66 on page 749](#).

Related reading: For a discussion on the recoverability of Fast Path status, see [Fast Path recovery \(Communications and Connections\)](#).

RCVYRESP=

Specifies whether the status of full-function response mode can be recovered (YES) or not (NO). RCVYRESP applies to full-function response mode status, not to output messages. Even if full-function response mode status is not recovered, response mode output continues to be recoverable and is delivered asynchronously.

The following table describes the default values for RCVYRESP as they relate to the values specified on the SRMDEF keyword.

Table 67. RCVYRESP values related to SRMDEF values

SRMDEF value	RCVYRESP=YES	RCVYRESP=NO
SRMDEF=GLOBAL	Invalid	Valid (default)
SRMDEF=LOCAL	Valid	Valid (default)

Table 67. RCVYRESP values related to SRMDEF values (continued)

SRMDEF value	RCVYRESP=YES	RCVYRESP=NO
SRMDEF=NONE	Valid. However, only those terminals or users that are assigned SRM=LOCAL as an override to SRMDEF=NONE (through user descriptor or user exit) are eligible to recover full-function response mode. All other terminals and users use RCVYRESP=NO.	Valid (default)

If RCVYRESP is specified incorrectly, message DFS1920I is issued, and IMS uses the appropriate default from [Table 67 on page 749](#).

Restrictions:

- RCVYRESP=YES is invalid when IMS is using an RM resource structure to maintain TM resources (that is, when STM=YES in the DFSDCxxx member of the IMS PROCLIB data set).
- RCVYRESP=YES applies only to terminals or users that have a status recovery mode of LOCAL. If a terminal or user has a status recovery mode of GLOBAL or NONE, the terminal or user is automatically assigned RCVYRESP=NO.
- Full-function response mode is not recovered following an IMS shut down or failure. After an IMS cold start, warm start, or emergency restart, the node or user is no longer in full-function response mode. Full-function response mode is recovered following an XRF takeover for class-1 terminals only.
- The RCVYRESP value specified cannot be overridden for individual users or nodes using either ETO user descriptors, the user logon exit (DFSLGNX0), or the user signon exit (DFSSGNX0). Therefore, RCVYRESP=YES automatically applies to all terminals and users with a LOCAL status recovery mode.

RCVYSTSN=

Specifies whether the status of STSN terminals (SLUP, FINANCE, and ISC) can be recovered (YES) or not (NO).

The following table describes the default values for RCVYSTSN as they relate to the values specified on the SRMDEF keyword.

Table 68. RCVYSTSN values related to SRMDEF values

SRMDEF value	RCVYSTSN=YES	RCVYSTSN=NO
SRMDEF=GLOBAL	Valid (default)	Valid
SRMDEF=LOCAL	Valid (default)	Valid
SRMDEF=NONE	Invalid	Valid (default)

Restrictions: If SRMDEF=LOCAL, STSN recoverability (RCVYSTSN) and fast path recoverability (RCVYFP) must be the same. They must both specify YES or both specify NO. If SRMDEF=GLOBAL, Fast Path is always nonrecoverable, so if there is a failure during the execution of a fast path transaction, the STSN session must be restarted cold.

If RCVYSTSN is specified incorrectly, message DFS1920I is issued and IMS uses the appropriate default from [Table 68 on page 750](#).

RNR=NRNR | ARNR | NONE

Specifies that IMS should enable Rapid Network Reconnect (RNR) support for ACF/VTAM persistent sessions as defined on the ACF/VTAM APPL statement for IMS. This parameter is used as a system default for an unspecified RNR value for the OPTIONS= keyword at the terminal level.

ARNR

Specifies that a basic session reconnect should be done automatically by IMS following an IMS or ACF/VTAM restart. This level of session reconnect is to a data traffic reset point equivalent to logon without available signon data. A DFS3649 signon required message can be sent as appropriate for the terminal type and definition.

NRNR

Specifies that automatic session reconnect should not be done. The session is terminated following restart of IMS or ACF/VTAM.

NONE

Specifies that the RNR function should not be activated. This option can also be used to deactivate the RNR function if it was activated before the IMS restart.

Requirement: Changing this parameter after a previous IMS start does not require a cold start, although a cold start is recommended in order to clear persistent session data in VTAM and terminate IMS sessions that are waiting for an RNR reconnection. You must perform at least a warm start to allow the new specification to take effect.

SAPPLID=appl_ID

Specifies the application ID to be used when calling RACF, or equivalent product, during sign on. If SAPPLID= is not specified, the IMSID of that IMS is the default application ID. The application ID becomes important when Passtickets are used instead of passwords because the application ID is used in the RACF creation and verification of the Passticket.

Requirement: Changing this parameter after a previous IMS start does not require a cold start. You must perform a warm start, however, to allow the new specification to take effect.

SECCNT=0 | 1 | 2 | 3

Specifies the maximum number of terminal and password security violations to be accepted per physical terminal and the number of transaction command violations per transaction prior to master terminal notification of such violations. The default is 0, which nullifies notification to the master terminal. The number specified must be 0, 1, 2, or 3.

SIGNON=SPECIFIC | ALL

Specifies that either all (ALL) or specific (SPECIFIC) static terminals are required to sign on.

ALL

Specifies that all static terminals (except the master terminal) are required to sign on. The following devices are not required to sign on when SIGNON=ALL is specified:

- LU6.1 devices
- 3284/3286 devices
- SLU1 printer-only devices
- Master terminals

To require master terminals to sign on, specify the OPTIONS=SIGNON on the TYPE or TERMINAL macro.

SPECIFIC

Specifies that individual static terminals might be required to sign on. These terminals are specified in system definition with the OPTIONS=SIGNON parameter. SPECIFIC is the default.

SIGNTCO=

Specifies a user ID that IMS can use for transaction and command authority checking when a TCO terminal does not sign on. The user ID must be defined in RACF or a similar security product.

When the SIGNTCO parameter is used, IMS sets TCORACF to Y automatically. The TCO LTERM is signed on and the user ID is included in IMS log records.

If the SIGNTCO is not used and no /SIGN command was issued, then the control region user ID is used for authorization checking.

SLU2=EXR | NOEXR

Specifies whether all IMS-defined SLU2 terminals should be treated as with or without DFT architecture.

EXR

Specifies that all IMS-defined SLU2 terminals are treated as with DFT architecture. EXR is the default.

NOEXR

Suppresses the SNA exception response that proceeds an IMS error message. As a result of no exception response, the terminal PROG check is prevented, the keyboard is locked, and IMS is allowed to send the error message.

Requirement: Changing this parameter after a previous IMS start does not require a cold start. You must perform a warm start, however, to allow the new specification to take effect.

SMT0=name1 | (name1) | (name1,name2)

name1 specifies the node name of the secondary master terminal (SMT0). This name overrides the SMT0 node name that is specified during IMS system definition.

name2 specifies the name of the additional SMT0 resource that exists in an XRF environment. If *name2* is specified in a non-XRF environment, it is ignored.

If the PMTO parameter is not specified, the default SMT0 name (either one or both) that was specified during IMS system definition is used.

Requirement: Changing this parameter after a previous IMS start requires a cold start to take effect.

SMT0USID=userid

Specifies a user ID that IMS will use if the secondary MTO does not sign on for transaction authorization checking.

SMT01-8=name | (name) | (name,MASTER)

Specifies the first through the eighth LTERM names of the SMT0. The names you specify here override the first through the eighth LTERM names specified during IMS system definition. The LTERM name specified with the SECONDARY designation becomes the SMT0 LTERM. These LTERM names must be unique for each IMS system within a shared IMS environment.

Requirement: Changing this parameter after a previous IMS start requires a cold start to take effect.

SMT0G=DFSSMT0 | name

Specifies the generic LTERM name for the secondary master terminal. The default generic SMT0 LTERM name is DFSSMT0. Use the same generic LTERM name for all IMS systems within a shared IMS environment.

Requirement: Changing this parameter after a previous IMS start requires a cold start to take effect.

SRMDEF=

Specifies the status recovery mode for user and node resources. Valid values are GLOBAL, LOCAL, and NONE.

Related reading: In order to understand completely what the GLOBAL, LOCAL, and NONE values mean, you have to first understand how IMS classifies resource status. For a discussion of these concepts, see *IMS Version 15.4 System Administration*.

The default value of SRMDEF depends on the operating environment:

- GLOBAL is the default if a resource structure and shared queues are used.
- LOCAL is the default if a resource structure and shared queues are not used.

The following list describes the valid values for SRMDEF.

GLOBAL

The significant status of a resource is saved globally in the coupling facility resource structure every time the significant status changes, along with all other recoverable status for that resource. The resource status is restored at the next logon or sign on and is available from any IMS system in the IMSplex. Resource status is copied to the local system when that resource becomes active,

but is deleted from the local system when it becomes inactive. Status is not recovered in local IMS log records.

Requirement: Using a status recovery mode of GLOBAL requires a Resource Manager and a resource structure in the coupling facility. If STM=NO is specified, SRMDEF=GLOBAL is invalid.

LOCAL

The significant status is saved in local control blocks and log records, along with all other recoverable resource status. The resource status is restored at the next logon or sign on if the user or node returns to the same local IMS system. This status is not available on any other IMS system in the IMSplex.

LOCAL mode enforces an affinity for the user or node to the IMS system where the local status exists. This is referred to as RM affinity. IMS prevents the user or node from accessing any other IMS while local status exists. If the IMS system that has local status fails, the node and user are allowed access to another IMS system. In this case, the node or user does not recover any status and when the failed IMS restarts, the local status that existed is deleted.

Using a status recovery mode of LOCAL does not require a Resource Manager. If RM is not used to manage node or user resources, then no RM affinity is enforced.

NONE

The significant status is not saved by RM or in local log records. When the user signs on or the node logs on, the corresponding significant status does not exist.

STATICOUTSEC=NO | ALL | SREQ

Specifies whether IMS is to discard transaction reply messages for static VTAM terminals when the current user does not match the user associated with the output message. In addition, this tells IMS whether to exit any active or held conversations when a user signs off from a static VTAM terminal. The default is NO.

NO

This option tells IMS not to examine transaction reply messages, and to process them as normal. This is the default value.

ALL

This option tells IMS to examine all transaction reply messages that are to be delivered to all statically defined VTAM terminals, except for ISC terminals and MSC terminals.

There are 3 cases that you might see if you specify this option:

- If the transaction was initiated by a signed-on user, IMS delivers the transaction reply messages only if the same user is currently signed on to the terminal.
- If the transaction was initiated by a signed-on user, but a different user, or no user, is currently signed on to the terminal, the messages are discarded.
- If the transaction was initiated when no user was signed on, IMS delivers the messages as normal.

Messages will be discarded only when they are about to be sent to the terminal. For example, messages are discarded after a program access 1 (PA1) key is received.

If the terminal was in response mode, IMS sends a DFS3478 message to the terminal in place of the canceled transaction response message.

In addition, any active or held conversations will be exited when any user signs off from a static terminal, or the static terminal logs off.

SREQ

This option tells IMS to examine all transaction reply messages that are to be delivered to sign-on required statically defined VTAM terminals, except for ISC terminals and MSC terminals.

Sign-on required terminals are indicated by setting the **OPTIONS=** keyword to SIGNON in the **TYPE** or **TERMINAL** system definition macro, or by specifying **SIGNON=ALL** in the DFSDCxxx PROCLIB member.

If the transaction was initiated by a signed-on user, IMS delivers the transaction reply message only if the same user is currently signed on to the terminal. If a different user is currently signed on, the reply message is discarded. Messages will be discarded only when they are about to be sent to the terminal. For example, messages are discarded after a program access 1 (PA1) key is received.

For terminals that are not sign-on required, IMS does not examine transaction reply messages, and delivers the outputs.

If the terminal was in response mode, IMS sends a DFS3478 message to the terminal in place of the canceled transaction response message.

In addition, any active or held conversations will be exited when any user signs off from a sign-on required static terminal, or the sign-on required static terminal logs off.

Important:

To use ALL and SREQ keywords, you must have sign-on verification active, which requires at least one of the following startup parameters to be specified:

- **SGN=Y** (or equivalent **USER** keyword in the **/NRE** or **/ERE** command)
- **TRN=Y** (or equivalent **TRANAUTH** keyword in the **/NRE** or **/ERE** command)
- **ETO=Y**

Important: ALL and SREQ keywords also make any IMS conversations exited, either held or active, when a user signs off from a static terminal. When ALL is specified, IMS forces **RCVYCONV=** parameter to be NO for all statically defined VTAM terminals, except for ISC and MSC terminals. When SREQ is specified, IMS forces **RCVYCONV=** parameter to be NO for all statically defined VTAM terminals that have been defined as sign-on required terminals, except for ISC and MSC terminals.

Important: Normally, **RCVYCONV=NO** for statically defined terminals means that conversations are exited when the terminal logs off, not when a user signs off. However, when ALL or SREQ keyword forces **RCVYCONV=NO**, conversations are exited when a user signs off.

Important: If the terminal uses a Physical Terminal Output Edit exit (DFSCCTO0 or equivalent), Physical Terminal Output Edit exit does not get control if IMS discards the message as a result of the STATICOUTSEC processing. If IMS does not discard the message, DFSCCTO0 is called and the processing proceeds as normal. DFSCCTO0 could still request IMS to discard the message, even if the previous STATICOUTSEC processing did not discard it.

STM=YES | NO

Specifies whether (YES) or not (NO) IMS is to use the RM resource structure to manage TM resources. The resources that are managed include APPC descriptors, VTAM LTERMS, MSNAMEs, VTAM terminal nodes, users, and user IDs. The default is YES.

A cold start is required if STM=NO is specified for installations that were previously using the resource structure.

Any change to the STM= specification requires a cold start of the TM component (COLDCOMM). This restriction is enforced during restart processing through the U233 ABENDU0233.

Note that transactions (both statically defined and CPI-C) are maintained in the resource structure independent of TM resources, regardless of the STM= specification.

If STM= is specified, but IMS is not using a resource structure, the specification is ignored.

TCOUSID=

Specifies a user ID that IMS can use for transaction and command authority checking when a TCO terminal does not sign on. The user ID must be defined in RACF or a similar security product.

When the TCOUSID= parameter is used, although IMS automatically sets TCORACF to Y, the TCO LTERM is not signed on and the user ID is not included in IMS log records.

If the TCOUSID= is not used and no /SIGN command was issued, then the control region user ID is used for authorization checking.

TRUNC=Y | N

Specifies the system default for the truncated data options used for IMS conversational transactions. If a transaction definition (TRANSACT) does not specify a truncated data option, the system default is used when a conversation starts for the first time.

Requirement: Changing this parameter after a previous IMS start does not require a cold start. You must perform a warm start, however, to allow the new specification to take effect.

VACBOPN=INIT | DELAY

Specifies that the opening of the IMS VTAM ACB is delayed until a /START DC command is issued. This parameter is optional. The following is an example of using the VACBOPN parameter.

- An IMS system is restarted (after an emergency restart) and this system includes many Automated Teller Machines (ATMs). All the ATMs attempt to connect immediately. The logon attempts are rejected by VTAM until IMS opens the VTAM ACB.

If, however, the VTAM ACB is opened during initialization, VTAM begins queuing the logon requests. The programs in the ATMs wait for a short period of time for a response and then time out. When the timeout occurs, an UNBIND request is sent and this is also queued. This scenario continues until the logon is successful. Meanwhile, IMS has to complete its initialization and then process all the log records for the emergency restart.

After the successful completion of the emergency restart, the operator can issue a /START DC command to tell VTAM to start accepting logon requests. When this finally happens, there are many UNBIND requests on the queue. At this point, the logon requests are queued behind enough error processing that they also time out.

In some situations, apparently the IMS system is looping (because no sessions can get connected) and the operator is tempted to terminate IMS. Using the VACBOPN=DELAY parameter alleviates this problem by delaying the queuing of the logon requests until IMS is ready to start accepting the logon requests (when the /START DC command is issued).

INIT

Specifies that the IMS VTAM ACB is opened when IMS initializes.

DELAY

Specifies whether the IMS VTAM ACB is opened when a /START DC command is issued.

Requirement: Changing this parameter after a previous IMS start does not require a cold start. You must perform a warm start, however, to allow the new specification to take effect.

WTORUSID=

Specifies a user ID that IMS uses if the WTOR (system console) does not sign on for transaction authorization checking.

If you do not specify WTORUSID, the control region's user ID is used for any other terminal that does not sign on.

If both SIGNON=ALL and WTORUSID= are specified, the specification for WTORUSID= overrides the SIGNON=ALL specification for the system console.

Related concepts

[“IMS Syntax Checker” on page 381](#)

The Syntax Checker is an ISPF application that helps you define, verify, and validate parameters and their values in the members of the IMS PROCLIB data set. Use the IMS Syntax Checker to avoid typographical and syntactical errors when modifying the parameter values for the IMS PROCLIB data set members.

DFSDFxxx member of the IMS PROCLIB data set

The DFSDFxxx member of the IMS PROCLIB data set consolidates the specification of processing options for many different IMS components and functions.

The parameters in the DFSDFxxx member are organized into sections. Each section has a different purpose and begins with a predefined header that identifies the section. Each section supports different parameters and syntax.

In the sections of the DFSDFxxx member you can specify processing options for the following IMS components and functions:

- Databases
- DDL options for database resources that are defined by using SQL data definition language (DDL)
- Dynamic database buffer pools
- Dynamic resource definition (DRD)
- Exit routines
- The Fast Path 64-bit buffer manager
- The IMS abend search and notification procedure
- The IMS catalog
- The IMS Common Service Layer (CSL)
- The IMSRSC repository
- The IMS type-2 trace tables
- Multiple Systems Coupling (MSC)
- Shared queues
- Processing options for the IMS Logger

All the sections within the DFSDFxxx member of the IMS PROCLIB data set are optional. If you include a section for any of the functions, the section must begin with the appropriate predefined header.

A DFSDFxxx member of the IMS PROCLIB data set consists of one or more fixed-length character records (the configuration data set can be of any LRECL greater than eight, but it must be fixed record format). The rightmost-eight columns are ignored but can be used for sequence numbers or any other notation. Keyword parameters can be specified in the remaining columns in free format, and they can contain leading and trailing blanks. You can specify multiple keywords in each record; use commas or spaces to delimit keywords. Statements that begin with a “*” or “#” in column 1 are comment lines and are ignored. Additionally, comments can be included anywhere within a statement by enclosing them between “/* ” and “*/”, for example, /* PROCLIB comments */. Values that are specified in this member of the IMS PROCLIB data set are case-sensitive. In general, use uppercase for all parameters.

You can use the IMS Syntax Checker to modify the DFSDFxxx member of the IMS PROCLIB data set.

CATALOG and CATALOGxxxx sections of the DFSDFxxx member

The CATALOG and CATALOGxxxx sections contain options for an IMS catalog. The section headers must be specified as <SECTION=CATALOG> or <SECTION=CATALOGxxxx>. The CATALOG and CATALOGxxxx sections are valid in DB/DC, DBCTL, DCCTL and batch environments.

Use the CATALOG section header to specify options for the IMS catalog in a single-system environment or in a data sharing environment where a single IMS catalog supports multiple IMS systems. In a data sharing environment, the CATALOG section defines the IMS catalog for all IMS systems, except those IMS systems for which a CATALOGxxxx section is defined.

Use the CATALOGxxxx section header to specify options for an IMS catalog in a data sharing environment where multiple IMS systems share a single DFSDFxxx member, but do not share a single IMS catalog. Specify one CATALOGxxxx section for each IMS system that shares this DFSDFxxx member and that requires a unique IMS catalog. The section header must be specified as <SECTION=CATALOGxxxx>, where xxxx is the IMS ID of the IMS system that the IMS catalog supports.

A DFSDFxxx member can contain any number of CATALOGxxxx sections, but only one CATALOG section.

Unless the Catalog Definition exit routine (DFS3CDX0) is used as an alternative, the CATALOG and CATALOGxxxx sections of the DFSDFxxx member are required by the batch jobs and utilities that use the IMS.PROCLIB database. This is an exception to the rule that all sections of the DFSDFxxx member of the IMS.PROCLIB data set are optional for batch jobs. Batch utilities do not use CATALOGXXXX sections. The CATALOGxxxx sections enable users to maintain separate catalog sections in a common DFSDFxxx PROCLIB member where a unique CATALOGxxxx section applies to a specific IMS system. This is so that each IMS in an IMS Plex™ can share the same DFSDFxxx PROCLIB member, and be able to specify different catalog attributes. If a CATALOGxxxx section is not provided, the default CATALOG section is used. Batch utilities only use the CATALOG section.

Important: If you are performing a first-time initialization of the CATALOG, you must populate the CATALOG and then restart IMS to complete the initialization.

Syntax

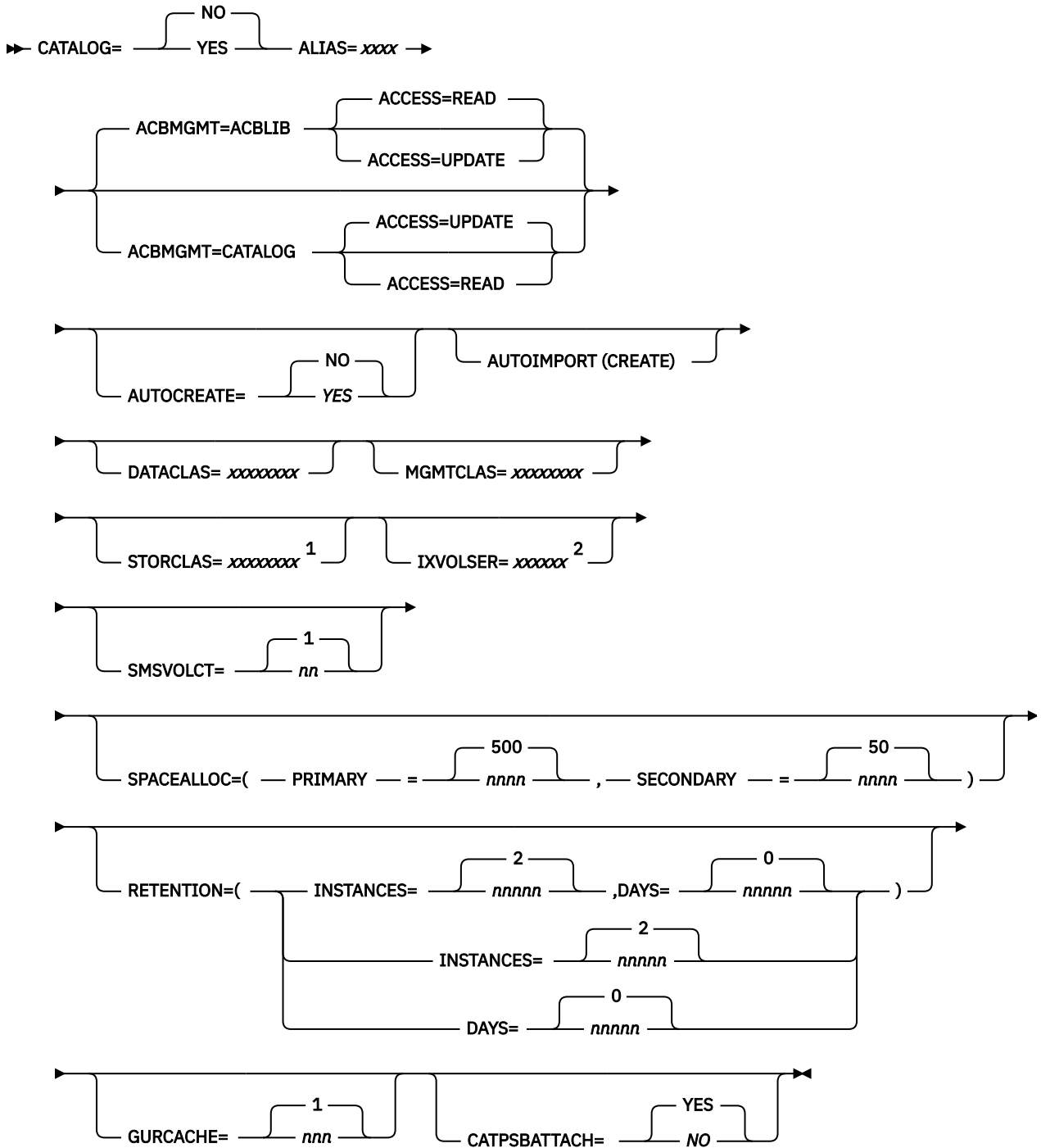

Notes:

- ¹ STORCLAS is required when IMS creates the catalog data sets automatically, because the data sets are managed by SMS.
- ² IXVOLSER is required when IMS creates the catalog data sets automatically and catalog data sets are not managed by SMS.

Parameters

The CATALOG and CATALOGxxxx sections of the DFSDFXxx member of the IMS.PROCLIB data set both use the same parameter list and syntax.

ACBMGMT=

Specifies whether IMS manages the active application control blocks (ACBs) in the IMS catalog or your installation manages the ACBs in ACB libraries (ACBLIBs).

You can specify the following values on the ACBMGMT parameter:

ACBLIB

Specifies that the active ACBs are managed by your installation in ACBLIB data sets.

When ACBLIB is in effect, you are required to use the PSB and DBD generation utilities to define your databases and program views. You are also required to use the ACB Maintenance utility to generate the ACBs into an ACBLIB data set. To activate the ACBs in online IMS systems, you must use the online change process.

The following catalog resource members must be included in the PSB and DBD libraries:

- DFSCD000
- DFSCX000
- DFSCPL00
- DFSCP000
- DFSCP001
- DFSCP002
- DFSCP003

ACBLIB is the default.

CATALOG

Specifies that the active ACBs are managed by IMS in the IMS directory data sets of the IMS catalog.

Do not specify CATALOG until after you create the IMS directory and load it with the active ACBs by running the IMS Catalog Populate utility (DFS3PU00) with the MANAGEDACBS=SETUP statement.

When CATALOG is in effect, you can define your databases and program views by using either the PSB and DBD generation utilities or by using DDL. If you use the IMS generation utilities, you still need to generate the ACBs and load them into the IMS directory by using IMS utilities. If you use DDL, IMS creates the ACBs for you. In either case, any new and changed ACBs that are not activated automatically can be activated in online IMS systems by issuing the IMS type-2 command IMPORT DEFN SOURCE(CATALOG) command.

Specifying CATALOG changes the default access type of the IMS catalog from READ to UPDATE.

ACCESS=

An optional keyword that specifies the access type of the IMS catalog.

The following values are valid for the ACCESS parameter.

READ

The data in the IMS catalog is read-only.

When ACBMGMT=ACBLIB, READ is the default.

UPDATE

The data in the IMS catalog can be updated.

When ACBMGMT=CATALOG, UPDATE is the default.

Note: If neither read or update are specified the catalog retains its previous access.

ALIAS=xxxx

Specifies a 4-character alphanumeric name prefix that is used to address the catalog database. References to the alias name are dynamically replaced with the internal catalog database and catalog secondary index names (DFSCD000 and DFSCX000) at runtime.

This parameter is required for all environments. If you do not want to use catalog aliasing, use DFSC as the alias prefix.

AUTOCREATE=N|Y|NO|YES

For full-function databases, HALDB databases, and DEDB databases. If you are using DDL CREATE statements to define a new database or program view, use this parameter to perform the following functions:

- Specifies whether IMS automatically loads the ACBs into the IMS directory, activating the ACBs in the online system.
- Creates runtime attribute blocks.
- If specified to create a DEDB database, automatically creates area data sets (ADS).

If **CREPGM=Y** is specified, the program directory control blocks (PDIRs) in the online systems, and the data sets are also created. The runtime attribute blocks will be exported to the repository only if **AUTOEXPORT** is in force in the DRD definitions. If this parameter is specified for full-function databases, all actions are performed except the creation of the data sets.

Both **AUTOCREATE** and **AUTOIMPORT (CREATE)** can be specified at the same time. If both **AUTOIMPORT (CREATE)** and **AUTOCREATE=YES** are specified, only **AUTOCREATE=YES** is processed.

If both **AUTOIMPORT (CREATE)** and **AUTOCREATE=NO** are specified, only **AUTOIMPORT (CREATE)** is processed.

AUTOIMPORT(CREATE)

For full-function databases, HALDB databases, and DEDB databases. If you are using DDL CREATE statements to define a new database or program view, use this parameter to perform the following functions:

- Specifies whether IMS automatically loads the ACBs into the IMS directory, activating the ACBs in the online system.
- Creates runtime attribute blocks.

If **CREPGM=Y** is specified, the program directory control blocks (PDIRs) in the online systems and the data sets are also created. The runtime attribute blocks will be expected to the repository only if **AUTOEXPORT** is in force in the DRD definitions. If this parameter is specified for full-function databases, all actions are performed except the creation of the data sets.

Both **AUTOCREATE** and **AUTOIMPORT (CREATE)** can be specified at the same time. If both **AUTOIMPORT (CREATE)** and **AUTOCREATE=YES** are specified, only **AUTOCREATE=YES** is processed.

If both **AUTOIMPORT (CREATE)** and **AUTOCREATE=NO** are specified, only **AUTOIMPORT (CREATE)** is processed.

CATALOG=

Specifies whether the IMS catalog is enabled or disabled.

NO

The IMS catalog is disabled. This value is the default and is used if no CATALOG section is specified.

YES

The IMS catalog is enabled.

CATPSBATTACH =

Specifies whether or not 3 catalog PCBs are dynamically attached to the end of the user's PSB. For more information about cases in which dynamic attach should be used, see [Application programming with the IMS catalog \(Application Programming\)](#).

YES

Dynamic attach of the catalog PCBs to the user's PSB is enabled. This value is the default.

NO

Dynamic attach of the catalog PCBs to the user's PSB is disabled.

DATACLAS=xxxxxxx

Data class for automatically generated, SMS-managed catalog data sets.

GURCACHE=

Specifies the amount of storage, in gigabytes, to allocate in 64-bit memory to cache XML documents that are generated as responses to GUR calls. The valid values are 1 - 999. The default is 1.

Only online IMS regions are supported. DCCTL is not supported.

You are required to review the z/OS systems 64-bit MEMLIMIT and the IMS JCL to determine if a job's MEMLIMIT is set. If none is set, then the default MEMLIMIT is 2 gigabytes. If additional storage is needed then setting the MEMLIMIT value is required to avoid abending due to an RSM storage shortage.

The storage pool is named GURIN64.

IXVOLSER=xxxxxx

Volume serial number for all primary and secondary catalog indexes.

Important: This parameter is required when IMS creates the catalog data sets automatically and catalog data sets are not managed by SMS.

MGMTCLAS=xxxxxxx

Management class for automatically generated, SMS-managed catalog data sets.

RETENTION=

This optional statement specifies the default retention criteria for the DBD and PSB records in the IMS catalog. These values are used by the IMS Catalog Record Purge utility (DFS3PU10) to remove outdated or unnecessary DBD and PSB segment instances and records from the catalog database.

You can specify the INSTANCES parameter, the DAYS parameters, or both.

DAYS=nnnnn

Specifies the number of days that the DBD and PSB instances in the IMS catalog must be retained before they can be deleted. When the age of a DBD or PSB instance in a DBD or PSB record exceeds this value, the instance is eligible for deletion by the DFS3PU10 utility.

The keyword accepts a decimal value 0 - 65535. When 0 is specified, the age of a DBD or PSB instance is ignored when the DFS3PU10 utility determines the eligibility of an instance for deletion. The default is 0.

INSTANCES=nnnnn

Specifies the number of DBD and PSB instances that must be retained in DBD and PSB records in the IMS catalog before any instances can be deleted.

For DBD instances, if database versioning is used, this value is the number of instances of the DBD that must be retained for each version of the DBD.

When the number of instances exceeds this value, the DFS3PU10 utility deletes the excess instances. The instances with the oldest ACB generation time stamps are selected for deletion. This value is a decimal value 1 - 65535. The default is 2.

VERSIONS=nnnnn

Obsolete. Use the INSTANCES keyword instead. The VERSIONS keyword is supported for compatibility purposes only.

SMSVOLCT=nn

Number of volumes that are created by the Catalog Populate utility for use by SMS-managed data sets. The valid range for this value is 1-20. The default is 1.

SPACEALLOC=(PRIMARY=nnnn SECONDARY=nnnn)

This value is a percentage that is added to the IMS-computed size of the primary and secondary catalog data sets. The default for the primary data set is 500% and the default for the secondary data set is 50%. You can specify any value 0 - 9999 for both parameters.

STORCLAS=xxxxxxx

Storage class for automatically generated, SMS-managed catalog data sets. Required for SMS-managed catalog data sets.

Example of the CATALOG section with retention criteria

This specification example retains up to four instances of all DBDs and PSBs in all DBD and PSB records in addition to the active instance for at least one year.

```
//*****  
/* IMS Catalog Section */  
/*****  
<SECTION=CATALOG>  
CATALOG=Y /*Enable IMS catalog*/  
ALIAS=DFSC /*Use standard catalog prefix DFSC*/  
RETENTION=(INSTANCES=5,DAYS=365) /*Retention criteria*/  
/*****  
/* */  
/*****
```

Example of the CATALOG section for an unregistered IMS catalog

```
//*****  
/* IMS Catalog Section */  
/*****  
<SECTION=CATALOG>  
CATALOG=Y /*Enable IMS catalog*/  
ALIAS=DFSC /*Use standard catalog prefix DFSC*/  
/*****  
/* Database Section */  
/*****  
<SECTION=DATABASE>  
UNREGCATLG=(DFSCX000,DFSCD000) /*Unregistered IMS catalog DB names*/  
/*****  
/* */  
/*****
```

Related concepts

[“IMS management of ACBs” on page 252](#)

IMS can manage the runtime *application control blocks* (ACBs) for databases and program views for you. You can define databases and program views by using SQL DDL statements or by using the IMS generation utilities.

Related tasks

[“Setting up the IMS catalog” on page 249](#)

The following steps provide a high-level overview of setting up the IMS catalog for the first time.

Related reference

[IMS Catalog Populate utility \(DFS3PU00\) \(System Utilities\)](#)

COMMON_SERVICE_LAYER section of the DFSDFxxx member

The COMMON_SERVICE_LAYER section of the DFSDFxxx member of the IMS PROCLIB data set specifies options for the Common Service Layer (CSL), such as IMSplex name, ACB sharing, global online change, command authorization checking, OLCSTAT, DRD, and global resource status. The section is defined by the header <SECTION=COMMON_SERVICE_LAYER>. The COMMON_SERVICE_LAYER section is valid in DB/DC, DBCTL, and DCCTL environments.

Syntax

The syntax of the parameters that are specified for the CSL in the DFSDFxxx member of the IMS PROCLIB data set is the same as the syntax of the parameters specified for CSL in the DFSCGxxx member of the IMS PROCLIB data set.

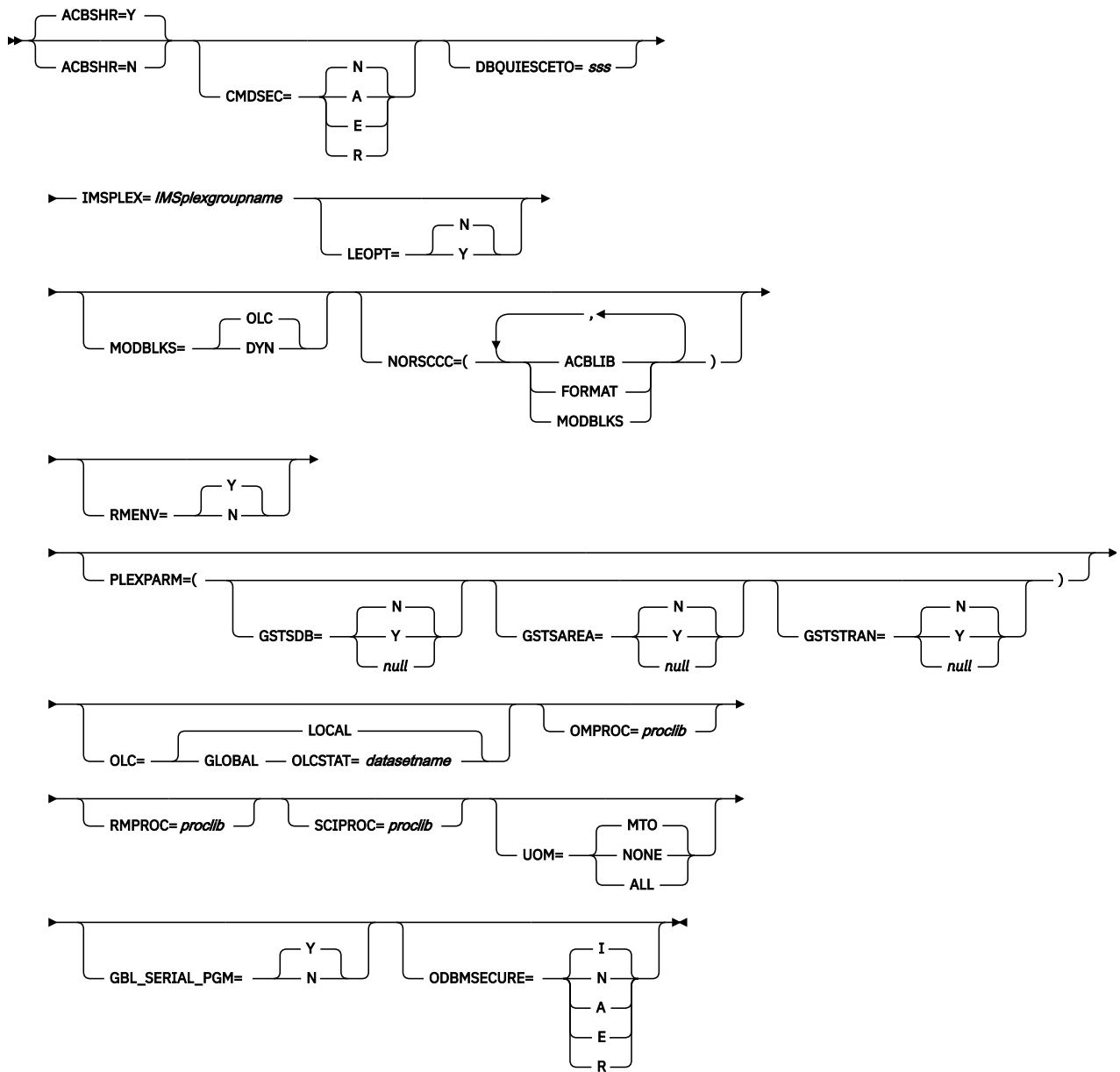

Parameters

All of the parameters that are valid in the DFSCGxxx member of the IMS PROCLIB data set are valid in the DFSDfxxx member of the IMS PROCLIB data set. If you specify values in both the DFSCGxxx member of the IMS PROCLIB data set and the CSL section of the DFSDfxxx member of the IMS PROCLIB data set, the values specified in the DFSCGxxx member override the values specified in the DFSDfxxx member.

ACBSHR=

Specifies whether this IMS system shares a common set of application control blocks (ACBs) with other IMS systems in an IMSplex. The ACBSHR= parameter determines whether changes to a set of ACBs must be coordinated across multiple IMS systems.

The shared set of ACBs can be in either ACB libraries or, if the IMS management of ACBs is enabled, a shared IMS catalog.

The ACBSHR parameter can be specified in both the DFSCGxxx member and the COMMON_SERVICE_LAYER section of the DFSDfxxx member in the IMS PROCLIB data set. If ACBSHR

is specified in both members, IMS uses the ACBSHR value that is specified in the DFSCGxxx member of the IMS PROCLIB data set.

In an environment that uses ACB libraries, each IMS system that shares an OLCSTAT data set must have the same value for ACBSHR=. If the ACBSHR= values are not the same, the INIT OLC PREPARE TYPE (ACBMBR) command is rejected.

When the IMS management of ACBs is enabled by ACBMGMT=CATALOG, the ACBSHR parameter alone determines which IMS systems are included in the global coordination of ACB changes. ACB changes are activated by the IMPORT DEFN SOURCE(CATALOG) command. The Online Change process is not used for ACB changes when ACBMGMT=CATALOG.

Y

Specifies that the set of ACBs that is used by this IMS system is shared by other IMS systems. Any changes to the shared set of ACBs must be coordinated among the sharing IMS systems.

If ACB libraries are used and OLC=GLOBAL, the global Online Change process requires both the CSL Resource Manager (RM) and an OLCSTAT data set to coordinate changes to ACBs among the online IMS systems in the IMSplex.

If the IMS management of ACBs is enabled, RM is required to coordinate ACB changes globally among all online IMS systems that specify ACBSHR=Y in an IMSplex. The OLC process is not used, so the OLC= parameter and the OLCSTAT data set do not apply.

When IMS manages ACBs, the ACBSHR= specification of each IMS system in the IMSplex determines whether the IMS system is included in the global coordination of ACB changes.

If ACBSHR=Y is specified in the command master when the **IMPORT DEFN SOURCE(CATALOG)** command is issued, the **IMPORT DEFN** command is routed to and processed by all IMS systems in the same IMSplex that also specify ACBSHR=Y, even if they are not specified on the ROUTE parameter in TSO SPOC. If any systems that specify ACBSHR=N other than the command master are specified on the ROUTE parameter, those IMS systems also attempt to process the **IMPORT DEFN** command, but processing is asynchronous and succeeds only if those systems have pending ACB changes in a separate IMS catalog.

If ACBSHR=Y is specified for IMS systems in a sysplex data sharing environment, you must specify PDESHARING(EXTENDED) in the IGDSMSxx member of SYS1.PARMLIB for each z/OS system in the sysplex.

N

Specifies that this IMS system uses its own dedicated set of ACBs.

If ACBSHR=N is specified in the command master when the IMPORT DEFN SOURCE(CATALOG) command is issued, the IMPORT DEFN command is processed locally only, unless other IMS systems that also specify ACBSHR=N are specified on the ROUTE parameter in TSO SPOC. If other IMS systems also process the IMPORT DEFN command, but they do so asynchronously and only if they have pending ACB changes in their own IMS catalog.

CMDSEC=

Specifies whether IMS should perform security checking on commands that are routed from OM, and if so, whether RACF or the Command Authorization exit routine (or both) should be used. If IMS performs the security checking on commands, the CMDSEC keyword also specifies whether RACF, the IMS Command Authorization exit routine (DFSCCMD0), or both should be used. This option applies only to IMS type-1 commands that can be issued through the OM API.

For type-2 commands (that are only allowed through the OM API, not allowed from the IMS master terminal), all security checking is performed by OM and is controlled by the CMDSEC= parameter on the OM startup JCL or on the OM initialization member of the IMS PROCLIB data set (CSLOIxxx).

Recommendation: Use OM command security instead of IMS security. By allowing OM to perform the security checks, commands which fail security authorization are not routed to IMS, which reduces processing overhead and network traffic. When IMS command security is used, you must ensure that all IMS systems use the same security profiles and user exits. If IMS systems in the same IMSplex use different security rules, the results of command security checking may be unpredictable.

A

Specifies that both RACF and DFSCCMD0 are to be called (options E and R). RACF is called first. Then the security authorization facility (SAF) return code, RACF return code, and RACF reason code are passed to DFSCCMD0.

E

Specifies that the Command Authorization exit routine is to be called for command authorization.

N

Specifies that no authorization checking is to be done. Security checking can still be performed by OM depending on the specification of the OM CMDSEC= parameter.

R

Specifies that RACF is to be called for command authorization.

DBQUIESCETO=

The amount of time, in seconds, that the **QUIESCE** command waits for currently running applications to commit before the **QUIESCE** command is aborted. This value applies only when the quiesce function is initiated. The actual time required for the **QUIESCE** command varies and might exceed this timeout value. The default value is 30 seconds. sss must be a non-zero value 1 - 999. You can also specify this timeout value in the COMMON_SERVICE_LAYER section of the DFSDFxxx member of the IMS PROCLIB data set, or override the value using the appropriate **UPDATE** command for the resource type, for example, **UPDATE DATAGRP NAME(name) START(QUIESCE) SET(TIMEOUT(10))**.

GBL_SERIAL_PGM=Y | N

Specifies whether (Y) or not (N) the sysplex serial program management feature of IMS is active. The default is Yes.

This parameter can be specified in both the DFSCGxxx and DFSDFxxx members of the IMS PROCLIB data set. If it is specified in both members, IMS uses the GBL_SERIAL_PGM value that is specified in the DFSCGxxx member.

IMSPLEX=

Specifies a one- to five-character identifier. IMS appends this identifier to "CSL" to create the IMSplex group name. All IMSplex members (OM, RM, IMS, CQS) that are in the same IMSplex sharing group sharing either databases or message queues must specify the same identifier. IMS has no way to enforce this; the user is responsible for ensuring that the IMSplex name is correctly specified. The same identifier must also be used for the IMSplex= parameter in the CSLSIxxx, CSLOIxxx, CSLRIxxx, and CQSIPxxx members of the IMS PROCLIB data set.

When RMENV=N, IMSPLEX= specifies a one- to five-character name of the IMSplex that OM, SCI, and the IMS control regions join. This IMSplex is simply a grouping of all address spaces that are managed by one or more OMs.

This parameter is required.

LEOPT=Y | N

Specifies whether IMS should allow IBM Language Environment for z/OS (LE) dynamic runtime parameter overrides.

MODBLKS=

Specifies whether resources in the IMS.MODBLKS data set are defined dynamically or by online change. These resources include databases, programs, routing codes, and transactions. This attribute can only be changed on an IMS cold start. If the value is changed for the next IMS warm or emergency restart, IMS restart terminates, and abend U0168 is issued.

DYN

Enables dynamic definition for resources in the IMS.MODBLKS data set. Resource definitions can be dynamically added, changed, or deleted by using online commands, including CREATE, DELETE, and UPDATE. Online change for resources in the IMS.MODBLKS data set that is initiated by a /MODIFY PREPARE MODBLKS or INITIATE OLC PHASE(PREPARE) TYPE(MODBLKS) command is not allowed.

OLC

Enables online change for resources in the IMS.MODBLKS data set. Resource definitions can be added, changed, or deleted by using online change. Online change commands for resources in the IMS.MODBLKS data set include /MODIFY PREPARE MODBLKS or INITIATE OLC PHASE(PREPARE) TYPE(MODBLKS). When MODBLKS=OLC, UPDATE commands that update runtime values (such as a transaction class) are permitted. This is the default.

ODBMSECURE=

Specifies whether IMS performs security checking on the PSB resource for an ODBM thread at the time of the allocate PSB (APSB) request. The RACF general resource class (RCLASS), AIMS or Axxxxxxx (where xxxxxxx is the value specified on the RCLASS= initialization EXEC parameter), is used for PSB resource checking.

Specifying any value other than ODBMSECURE=I overrides the **ISIS=** and **ODBASE=** parameters for APSB requests from an ODBM connector.

I

Ignore. Specifies that the ODBMSECURE= parameter is to be ignored. I is the default.

N

None. Specifies that no security checking is to be performed for APSB requests from an ODBM thread. Specifying ODBMSECURE=N overrides both the **ISIS=** and **ODBASE=** parameters.

A

All. Specifies that both RACF and the IMS RASE user exit routine are to be called (options E and R) for PSB authorization. RACF is called first. The SAF return code and the RACF return and reason codes are passed to the IMS RASE user exit routine.

E

Exit. Specifies that the IMS RASE user exit routine is to be called for PSB authorization.

R

RACF. Specifies that RACF is to be called for PSB authorization by using the AIMS or Axxxxxxx general resource class.

NORSCCC=()

Resource consistency checking is no longer performed for ACBLIB, FMTLIB, and MODBLKS libraries, regardless of whether there is a resource structure or if values are specified on NORSCCC. The NORSCCC keyword is supported for compatibility, but its values are ignored.

Specifies that no resource consistency checking is to be performed for the specified resources. The resources to not check for consistency must be enclosed within parentheses and separated by commas. The NORSCCC keyword must precede the left parenthesis. NORSCCC is an optional parameter.

If a resource structure is defined for the IMSplex, by default, consistency checking is performed for ACBLIB, FORMAT, and MODBLKS. Consistency checking is performed on the data set names; it is not performed on the resources that reside in the libraries. Resource consistency checking is useful for cloned systems that either share all these data sets or use the same data set names on each IMS.

If no resource structure is defined, no resource definition consistency checking is performed.

When RMENV=N, the NORSCCC parameter is ignored.

Specify one or more of the following parameters:

ACBLIB

The ACBLIB data set names are not checked for consistency. The IMS systems in the IMSplex do not need to define the same data sets for the ACBLIB library. ACBLIB applies only if OLC=GLOBAL is specified.

FORMAT

The FORMAT data set names are not checked for consistency. The IMS systems in the IMSplex do not need to define the same data sets for the FORMAT library. FORMAT applies only if OLC=GLOBAL is specified.

MODBLKS

The MODBLKS data set names are not checked for consistency. The IMS systems in the IMSplex do not need to define the same data sets for the MODBLKS library. MODBLKS applies only if OLC=GLOBAL is specified.

OLC=LOCAL | GLOBAL

Specifies the scope of the online change. OLC=LOCAL means that the online change applies locally to each IMS. Local online change is prepared and committed by using the /MODIFY PREPARE and /MODIFY COMMIT commands on each local IMS. The local online changes must be manually coordinated across an IMSplex. OLC=GLOBAL means that the online change is coordinated across the IMSplex; ACBLIB member OLC requires OLC=GLOBAL. Global online change is prepared and committed by using the INITIATE OLC command. If global online change is enabled and a resource structure is defined, the MODBLKS, FORMAT, and ACBLIB data sets must be consistent across the IMSplex, unless resource consistency checking is omitted by the NORSCC keyword.

When the IMS management of ACBs is enabled, the OLC parameter does not apply to changes made to ACBs. Instead, the value of the ACBSHR= parameter determines whether IMS activates ACBs only locally or coordinates the activation globally when the **IMPORT DEFN SOURCE (CATALOG)** command is issued.

OLCSTAT=

Specifies the 1 - 44 character data set name of the OLCSTAT data set. OLCSTAT is ignored if OLC=LOCAL is specified. OLCSTAT is required if OLC=GLOBAL is defined. The OLCSTAT data set is a cataloged BSAM data set that contains global online change information and status. The data set name is used to dynamically allocate the data set when an IMS initialized, restarts, or is master of an online change phase.

All IMS systems in an IMSplex must refer to the same physical OLCSTAT data set. If a resource structure is defined to the IMSplex, IMS ensures that the OLCSTAT data set name is defined consistently for the IMSplex. If the OLCSTAT data set name definition is not consistent with the OLCSTAT defined to other IMS systems in the IMSplex, IMS initialization fails.

When the IMS management of ACBs is enabled, the OLCSTAT parameter does not apply to the activation of new or modified ACBs in online IMS systems.

RMENV=Y | N

Indicates whether (Y) or not (N) IMS requires an RM environment.

Y

Indicates that IMS requires an RM environment in order to use Resource Manager services. IMS initialization does not complete until IMS successfully registers with RM. This is the default.

N

Indicates that IMS does not require an RM environment and does not use Resource Manager services. IMS does not attempt to register with RM even if an RM address space is active. When RMENV=N, you do not need to define or start an RM address space. IMS commands and functions that require RM are not available in this environment.

When the IMS management of ACBs is enabled, a specification of RMENV=N limits the activation of ACB changes to the local IMS system. If the ACBs are shared by other IMS systems, as indicated by ACBSHR=Y, you must coordinate the activation of ACBs in the other systems separately.

When RMENV=N, online change is as follows:

- If OLC=LOCAL, use the /MODIFY command to initiate online change. The MODSTAT data set must be defined.
- If OLC=GLOBAL, use the INIT OLC command to initiate online change. The OLCSTAT data set must be defined; however, it cannot be shared between IMS systems.

You can change the value of RMENV= across IMS warm or cold starts.

RMPROC=

Specifies the one- to eight-character name of the member of the IMS PROCLIB data set that contains the procedure for the RM address space. This parameter is optional.

IMS does not start the RM address space specified by this parameter if another RM address space is already active in the IMSplex during IMS initialization.

If RMPROC= is not specified, start the RM address space before starting IMS. This start sequence can be performed through an automation program or by another IMS control region.

OMPROC=

Specifies the one- to eight-character name of the member of the IMS PROCLIB data set that contains the procedure for the OM address space. This parameter is optional.

IMS does not start the OM address space specified by this parameter if another OM address space is already active in the IMSplex during IMS initialization.

If OMPROC= is not specified, start the OM address space before starting IMS. This start sequence can be performed through an automation program or by another IMS control region.

PLEXPARAM=()

PLEXPARAM is optional. If you do not specify it, either the default value or a NULL value is used. Refer to the specific subparameter to determine whether the default or NULL value is used.

The PLEXPARAM parameter defines how global status is maintained for resources in an IMSplex. An IMS system that is initialized in an IMSplex checks to see if a global PLEXPARAM entry exists in the RM resource structure. If the entry exists, the IMS system uses the values. If no entry exists, the initializing IMS writes its resource definition values to the RM resource structure global PLEXPARAM entry. Any IMS system that initializes in that IMSplex after that uses the values stored by the first IMS system. If the subsequent IMS system has PLEXPARAM values that are different from the values in the global PLEXPARAM entry, message DFS3425I is issued, and values from the global PLEXPARAM entry are used.

To view the current PLEXPARAM values, use the `QUERY IMS` command. To update PLEXPARAM values, use the `UPDATE IMS` command.

If an IMS system is running in an IMSplex that does not include an RM, or the RM in the IMSplex does not use a resource structure, the PLEXPARAM parameter is ignored. No message is issued indicating that the parameter is ignored. All PLEXPARAM values are set to no (N).

In an FDBR system, the PLEXPARAM parameter is ignored. No message is issued indicating that the parameter is ignored. All PLEXPARAM values are set to no (N). However, an FDBR system and an XRF alternate system do maintain global PLEXPARAM values internally. You can use the `QUERY IMS SHOW(PLEXPARAM)` command to display PLEXPARAM values in an FDBR or XRF alternate system.

GSTSDB=

Specifies how global status for databases is kept in the IMSplex.

N

No global status is maintained for databases resources in the RM. This is the default value for DB/DC and DBCTL regions.

Y

Global status for databases is maintained in the RM.

null

No global status is maintained for databases resources in the RM. This is the default value for DCCTL regions.

A DCCTL system that initializes this value in the global PLEXPARAM entry writes a null value. If a DB/DC or DBCTL system later joins that IMSplex, that system updates the GSTSDB value in the global PLEXPARAM entry with the value from its PLEXPARAM initialization parameter.

GSTSAREA=

Specifies how global status for DEDB areas is kept in the IMSplex.

N

No global status is maintained for DEDB area resources in the RM. This is the default value for DB/DC and DBCTL regions.

Y

Global status for DEDB areas is maintained in the RM.

null

No global status is maintained for DEDB area resources in the RM. This is the default value for DCCTL regions.

A DCCTL system that initializes this value in the global PLEXPARM entry writes a null value. If a DB/DC or DBCTL system later joins that IMSplex, that system updates the GSTSDB value in the global PLEXPARM entry with the value from its PLEXPARM initialization parameter.

GSTSTRAN=

Specifies how global status for transactions is kept in the IMSplex.

N

No global status is maintained for transaction resources in the RM. This is the default value for DB/DC and DCCTL regions.

Y

Global status for transactions is maintained in the RM.

null

No global status is maintained for transaction resources in the RM. This is the default value for DBCTL regions.

A DBCTL system that initializes this value in the global PLEXPARM entry writes a null value. If a DB/DC or DCCTL system later joins that IMSplex, that system updates the GSTSDB value in the global PLEXPARM entry with the value from its PLEXPARM initialization parameter.

SCIPROC=

Specifies the one- to eight-character name of the member of the IMS PROCLIB data set that contains the procedure for the SCI address space. This parameter is optional.

If SCIPROC= is not specified, start the SCI address space before starting IMS. This start sequence can be performed through an automation program or by another IMS control region.

UOM=

Specifies which unsolicited output messages are sent to the Operations Manager:

MTO

Send only unsolicited output messages that are destined for the MTO, unsolicited output messages that are destined for the system console, or both, to OM. This is the default.

NONE

Do not send any unsolicited output messages to OM.

ALL

Send all unsolicited output messages to OM.

Example of the COMMON_SERVICE_LAYER section of the DFSDFxxx member

```
/*
/* Common Service Layer Section
/*
<SECTION=COMMON_SERVICE_LAYER>
ACBSHR=Y /* Share ACB libraries */
CMDSEC=N /* No cmd authorization checking */
IMSPLEX=PLEX1 /* IMSplex name */
OLC=GLOBAL /* GLOBAL online change */
OLCSTAT=IMSTESTS.IMS01.OLCSTAT /* OLCSTAT data set name */
MODBLKS=DYN /* DRD ENABLED; OLC DISABLED */
PLEXPARM=() /* GLOBAL resource status */
UOM=MTO /* Unsolicited output message support */

```

```

/*
/*****

```

Related tasks

[“Importing MODBLKS resource and descriptor definitions by using the automatic import function” on page 85](#)

With dynamic resource definition (DRD) enabled, you can enable the automatic import function so that MODBLKS resource and descriptor definitions are imported to IMS during IMS cold start processing.

Related reference

[“CSLRxxxx member of the IMS PROCLIB data set” on page 719](#)

Use the CSLRxxxx member of the IMS PROCLIB data set to specify parameters that initialize RM.

[“DFSCGxxx member of the IMS PROCLIB data set” on page 728](#)

Use the DFSCGxxx member of the IMS PROCLIB data set to specify parameters that are related to the Common Service Layer (CSL), including the Operations Manager (OM), the Resource Manager (RM), and the Structured Call Interface (SCI).

DATABASE section of the DFSDFxxx member

The DATABASE section of the DFSDFxxx member specifies options for databases, such as database versioning, the size of storage pools for ACBLIB members and release ownership of OLR at normal or abnormal shutdown of IMS. The section is defined by the header <SECTION=DATABASE>. The DATABASES section is valid in DB/DC, DBCTL, and batch environments.

Syntax

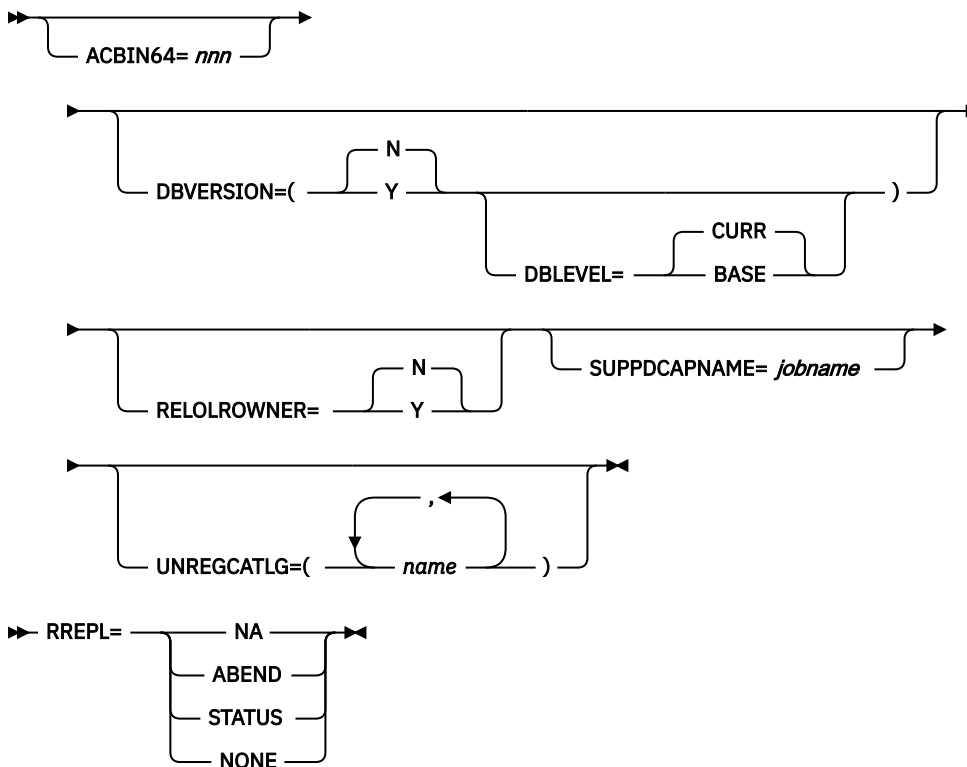

Parameters

ACBIN64=nnn

Specifies the amount of storage to allocate in 64-bit memory for non-resident PSB and DMB ACB members. Only online IMS regions types (not DCCTL or batch) are supported. The specification is in

gigabytes, where *nnn* can be a value 1 - 999. You can specify the 64-bit storage pool in all IMS region types.

DBVERSION=

Specifies whether database versioning is enabled. Valid values are Y and N. N is the default.

When DBVERSION=Y, database versioning is enabled. Database administrators can assign version numbers to different versions of the database definition (DBD) of a database. Application programs can then specify the version number of the DBD that they need on calls to the database. You can specify the DBD version number for an application program on the DBVER parameter of the PCB statement or the application program can specify it on the DL/I call INIT VERSION.

When database versioning is enabled, if an application program does not specify a version, by default the IMS system returns data to the application program by using the version of the DBD that is active in the ACB library. This version usually corresponds to the physical structure of the database.

The IMS system default can be changed to return data by using the DBD that contains DBVER=0 by specifying DBLEVEL=BASE in the database section of the DFSDFxxx member. At the application program level, the IMS system default can be overridden by specifying DBLEVEL=BASE in the PSBGEN macro during PSB generation.

When DBVERSION=N, or the DBVERSION parameter is omitted, database versioning is disabled. Application programs access all databases via the most recently generated DBD. If an application program specifies a version number on a call to a database, the application program either terminates with a 3303 abend or receives a BA status code, depending on how the application program is coded and whether the database is a Fast Path database. Version numbers that are specified on either a PCB or DBD are ignored by IMS.

DBLEVEL=

When database versioning is enabled, specifies the IMS system default for which version of a database definition (DBD) IMS uses to return data when an application program does not specify a database version.

DBLEVEL applies only when DBVERSION=Y is specified. When DBVERSION=N, DBLEVEL is ignored.

Valid values for DBLEVEL are CURR and BASE. The default value is CURR.

The IMS system default that is specified in the DFSDFxxx member can be overridden by specifying a DBLEVEL value in the definition of a program specification block (PSB) or by specifying a specific version number either in the definition of a program communication block (PCB) or in a DL/I INIT VERSION call that is issued by the application program.

When DBLEVEL=CURR and an application program does not specify a version number on a call to access the database, IMS returns data to the application program by using the database structure that is defined by the active members in the ACB library. Usually, the active ACB members define the actual current structure of the physical database.

When DBLEVEL=CURR is in effect, any existing application program that will not use the currently active version of the database require changes to the PSB, PCB, or the application program itself to specify the required version of the database. Specifying DBLEVEL=BASE in the definition of the PSB will return version 0 to all application programs that use the PCBs in the PSB. Otherwise, the specific required version must be specified either in the definition of the individual PCBs or in an INIT VERSION DL/I call that is issued by the application program.

Use DBLEVEL=CURR when most application programs are modified to use the current database structure, but a few application programs continue to require the structure of an older database version. For application programs that require the older version of a database, the required database version number can be specified on the DBVER= parameter of the PCB.

When DBLEVEL=BASE and an application program does not specify a database version number, IMS returns data to the application program by using the database structure that is defined by the DBD record in the IMS catalog that contains DBVER=0. DBVER=0 is the default version of a DBD before a DBVER value is specified explicitly on a subsequent version of a DBD. If multiple instances of a version-0 DBD exist in the IMS catalog, IMS uses the instance that has the most recent timestamp.

Use DBLEVEL=BASE for any of the following reasons:

- To update existing application programs gradually over time after changes are made to the database structure
- A large number of application programs cannot be modified to support a new database structure, either because the source code is no longer available or there are too many application programs to change
- It is not known which application programs will be affected by the change to the database

DBLEVEL=BASE allows existing application programs to continue using the original database structure, even after the structure of the database has been changed to support new application programs.

When DBLEVEL=BASE is specified, for the new or modified application programs that require the currently active database structure or that require any version of the database other than the version 0, you can specify DBLEVEL=CURR on the PSBGEN statement or specify a specific version number can be specified on the DBVER= parameter of the PCB statement. Application programs can also specify a version number by using the VERSION function of the INIT call of the DL/I API.

If DBLEVEL=BASE is in effect when an application program attempts to access a database without specifying a version number, but the DBD of the database that contains DBVER=0 is no longer in the IMS catalog, the application program fails with either an abend or a DL/I status code.

RELOLROWNER=

An optional keyword that sets the default behavior of OLR ownership when IMS terminates before finishing the operation. If this keyword is not included or if RELOLROWNER=N (the default value) is specified, the IMS system maintains ownership to resume the halted OLR when IMS restarts. If RELOLROWNER=Y is specified, IMS releases control when it terminates during an OLR so that another IMS system can continue the operation. In either case, you can override the default behavior with the OPTION parameter of the **INIT OLREORG** or **UPD OLREORG** commands.



Attention:

- If a forced shutdown occurs during an online reorganization that is using the RELOLROWNER=Y option, or the equivalent the OPTION(REL) keyword of the **INITIATE OLREORG** or **UPDATE OLREORG** commands, the IMS system that resumes the reorganization (if it is not the original system) must also use RELOLROWNER=Y or the OPTION(REL) keyword.
- If the resuming system does not use either the RELOLROWNER=Y parameter in the DFSDFxxx PROCLIB member or the OPTION(REL) keyword of the **INITIATE OLREORG** command, the **INITIATE OLREORG** command fails with completion code CA.

RREPL

Specifies whether to enable the Restricted Update mode on all the databases where reads are allowed for any program, but updates are allowed only for replication programs and authorized users.

The **CREATE DB** command cannot be used to set the RREPL value for the new database. You must use the **UPDATE DB** command to set a RREPL value for a newly created database.

During cold restarts, the RREPL value in the database section of the DFSDFxxx member is used to set the RREPL value on all databases, partitions, and areas.

During warm, ERE, and ERE Coldcomm restarts, the RREPL value in the DFSDFxxx member is used to enable or disable the Restricted Update mode. The RREPL value that is set to any value other than NA enables the Restricted Update mode. Note that the RREPL value in the DFSDFxxx member does not impact the RREPL setting on any database, partition, or area unless the value is set to NA.

NA

This is the default value and means that Restricted Update mode is disabled. You cannot use the **UPDATE DB** and **UPDATE AREA** commands to enable the RREPL mode. If you use the **UPDATE DB** and **UPDATE AREA** commands to enable the RREPL mode, those commands will fail with reason code 2074 and the error text "RREPL is not active".

ABEND

Restricted Update mode is enabled, and a U3303 abend occurs when unauthorized users try to make updates.

STATUS

Restricted Update mode is enabled, and an RR status code occurs when unauthorized users try to make updates.

NONE

Restricted Update mode is not enabled, and any user can make updates. However, you can use the **UPDATE DB** and **UPDATE AREA** commands to enable the RREPL mode.

SUPPDCAPNAME

Specifies the job name of a CCTL or ODBM address space for which data capture is suppressed. If you specify the job name of a CCTL or ODBM address space on this parameter, database or database segment updates that are invoked by the job are not captured by the Data Capture exit routine, even if the exit routine is specified on the **EXIT=** parameter of the DBD for the database.

UNREGCATLG=(name,name,...)

Identifies the IMS catalog databases and catalog secondary indexes that are to be used without being registered with DBRC.

Database names must be 1-8 characters. Separate multiple names with commas.

This parameter is optional and does not have a default value.

If an IMS catalog or secondary index database that is registered with DBRC is specified on the UNREGCATLG parameter, any attempt to populate the IMS catalog results in an abend.

Example of the DATABASE section of the DFSDFxxx member

```
/* Database Section */
/* Database Section */
<SECTION=DATABASE>
ACBIN64=8 /* Create 64-bit storage pool */
RELOLROWNER=Y /* Release ownership of OLR when IMS terminates */
DBVERSION=(Y,DBLEVEL=CURR) /* Database versioning enabled*/
/* Database Section */
/* Database Section */
```

```
/* Database Section */
/* Database Section */
<SECTION=DATABASE>
ACBIN64=8 /* Create 64-bit storage pool */
RELOLROWNER=Y /* Release ownership of OLR when IMS terminates */
/* Database Section */
/* Database Section */
```

Related reference

[Database Description \(DBD\) Generation utility \(System Utilities\)](#)

DDL section of the DFSDFxxx member

Use the DDL section of the DFSDFxxx member to specify options for DEDB area data sets that are allocated automatically during the processing of DDL CREATE DATABASE statements. The section must begin with the header <SECTION=DDL>. You must set AUTOCREATE=YES.

The <SECTION=DDL> can be refreshed to customize the data set information before each DDL submission without an IMS shutdown.

DEDB area data sets are allocated automatically during CREATE DATABASE processing only when AUTOCREATE=YES is specified in the <SECTION=CATALOG> section of the DFSDFxxx PROCLIB member.

Syntax

➔ DSN=(*cluster_name,db_type*) — DSNDATA=(*data_component_name,db_type*) ➔

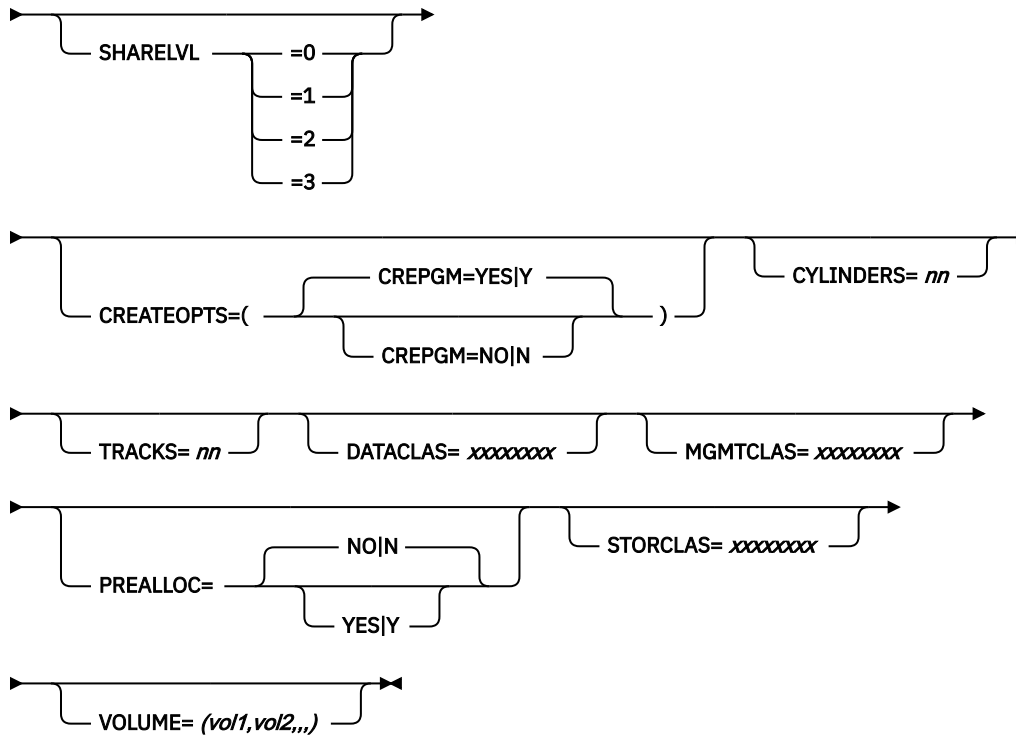

Parameters

The parameters of the DDL section of the DFSDFxxx member are described in the following list.

DSN=(*cluster_name,db_type*)

The definition of the VSAM cluster for the DEDB area. This parameter is required. You can specify a maximum of 44 characters and cannot use special characters, such as @, \$, or #.

cluster_name

Name of the VSAM cluster. You can include the &DBNAME and &AREANAME symbols. If you include the &DBNAME or the &AREANAME symbol, or both, the data set name is generated by replacing the symbols with the database name and the area name.

db_type

Can be the following:

TYPEFP

Fast Path DEDB databases.

The following example shows a definition for the **DSN=** parameter:

```
DSN=(AAAAAAAA.&DBNAME.&AREANAME.BBBBBBBB.CCCCCC,TYPEFP)
```

DSNDATA=(*data_component_name,db_type*)

The definition of the data component. This parameter is optional. You can specify a maximum of 44 characters and cannot use special characters, such as @, \$, or #.

data_component_name

Name of a VSAM data component. You can include the &DBNAME and &AREANAME symbols. If you include the &DBNAME or the &AREANAME symbol, or both, the data set name is generated by replacing the symbols with the database name and the area name.

db_type

If the **DSNDATA=** parameter is used, the following value is required for the *db_type* variable:

TYPEFP

Fast Path DEDB databases.

The following example shows a definition for the **DSNDATA=** parameter:

```
DSNDATA=(AAAAAAAA.&DBNAME.&AREANAME.BBBBBBBB.CCCCCCCC,TYPEFP)
```

SHARELVL=

Database data sharing level. The default value is 0.

CREATEOPTS=(CREPGM=YES|NO|Y|N)

Optional parameter. **CREATEOPTS=(CREPGM=YES|Y)** is the default. This parameter creates options to be used at DDL Auto Create|Auto Import processing at DDL CREATE submission.

CREPGM=YES|Y

The default value. DDL Auto Create|Auto Import creates a runtime program definition of EMP types if such definition does not exist and Dynamic Resource Definition is enabled at DDL CREATE PROGRAMVIEW processing. Default program descriptor is used with **BMPTYPE(Y)** as override.

CREPGM=NO|N

DDL Auto Create|Auto Import does not create a runtime program definition if such definition does not exist and Dynamic Resource Definition is enabled at DDL CREATE PROGRAMVIEW processing.

Note: Default database descriptor is used with **RESIDENT(Y)** as override for DEDB databases.

Manual or IMS checkpoint-triggered **EXPORT DEFN** command must be used to export runtime database definition and runtime program definition created by DDL Auto Import so that they would be recovered across an IMS cold start.

CYLINDERS=

The amount of space in cylinders allocated to the area data set. This parameter is required when the area data sets are not managed by SMS. The maximum value is 16777215.

TRACKS=

The amount of space in tracks allocated to the area data set. This parameter is required when the area data sets are not managed by SMS. If **CYLINDERS** parameter is specified, this parameter is ignored. The maximum value is 16777215.

DATACLAS=

Data class for automatically generated, SMS-managed area data sets. If **CYLINDERS** or **TRACKS** are specified, the value will override the space values specified in the class.

MGMTCLAS=

Management class for automatically generated, SMS-managed area data sets.

PREALLOC=

This parameter is for DEDBs with **SDEP** defined. **PREALLOC=NO|N** is the default.

If **PREALLOC=YES|Y**, the data set must be empty. Otherwise, terminate data set creation for the DEDB with **SDEP**.

If the value is **PREALLOC=NO|N** for a DEDB with **SDEP** defined, you can use **TRACKS=** or **CYLINDERS=** for data set allocation. Both **TRACKS=** and **CYLINDERS=** are required for **SDEP** message that is not accurate.

PREALLOC=YES|Y

Users pre-allocate area data sets for newly DDL created DEDB with **SDEP** defined. The DDL auto data set creation will use the pre-allocated data sets for DEDB with **SDEP**. The pre-allocated data sets must be empty for DDL auto data set creation to use to format and register the area data sets to **DBRC**.

When DDL Auto Create detects ADS cluster with the same entry name, DDL Auto Create deletes existing cluster and defines new cluster if SDEP is not defined. If SDEP is not defined, the DDL does not define cluster and formats this ADS, or register the ADS to DBRC.

When a ADS cluster is defined, you must specify the following parameters to define a DEDB ADS with SDEP:

- CYLINDERS= or TRACKS=
- SMS class: DATACLAS= or STORCLAS= or MGMTCLAS

PREALLOC=NO|N

This is the default. Users do not pre-allocate area data sets for newly DDL created DEDB with SDEP defined. DDL auto data set creation will use **CYLINDERS=** or **TRACKS=** parameter in <SECTION=DDL> of DFSDFxxx PROCLIB for space allocation, formatting, and registering area data sets to DBRC.

When DDL Auto Create detects ADS cluster with same entry name, it stops processing this ADS.

When DEDB does not have SDEP, DDL deletes and defines a new area data set when a duplicate area data set is found.

DDL calculates SPACE of AREA data sets to be created when DEDB doesn't have SDEP. **CYLINERS** and **TRACKS** of DDL section of DFSDFxxx are used when DEDB has SDEP.

STORCLAS=

Storage class for automatically generated, SMS-managed area data sets. Required for SMS-managed database data sets.

VOLUME=()

The volumes allocated for a DEDB area data set. You must use parentheses () to contain the values of this parameter, even if you specify only one volume. You can specify a maximum of 100 volumes. If you specify more than 100 volumes, only 100 volumes are used. This parameter is required when the area data sets are not managed by SMS.

The following example shows a VOLUME= parameter:

```
VOLUME=(vo11,vo12,vo13,,,,)
or
VOLUME=(vo11,
        vo12,
        vo13,
        ----
        voln)
```

Example of the DDL section

```
/*-----*/
/* DDL SECTION                                     */
/*-----*/
<SECTION=DDL>                                     /* Enabled DDL extensions function. */
SHARELVL=3                                        /* Required keyword if DEDB is to be shared */
DSN=(IMSTESTS.PLEX1.&DBNAME.&AREANAME.ADS,TYPEFP)
DSNDATA=(IMSTESTS.PLEX1.&DBNAME.&AREANAME.ADS.DATA,TYPEFP)
/* Required parameter DSN name, max 44 char*/
VOLUME=(DSHR09)                                   /* Required keyword the volume to be used */
TRACKS=75                                         /* Required the size of FP ADS in tracks */
```

Related concepts

[Using DDL to define databases and program views \(Database Administration\)](#)

[“IMS management of ACBs” on page 252](#)

IMS can manage the runtime *application control blocks* (ACBs) for databases and program views for you. You can define databases and program views by using SQL DDL statements or by using the IMS generation utilities.

[SQL programming reference \(Application Programming APIs\)](#)

DIAGNOSTICS_STATISTICS section of the DFSDFxxx member

The DIAGNOSTICS_STATISTICS section of the DFSDFxxx member specifies options for the IMS Abend Search and Notification procedure (DFSASNO) and for obtaining database and transaction statistics. The section is defined by the header <SECTION=DIAGNOSTICS_STATISTICS>. The DIAGNOSTICS_STATISTICS section is valid in DB/DC, DBCTL, and DCCTL environments.

Syntax

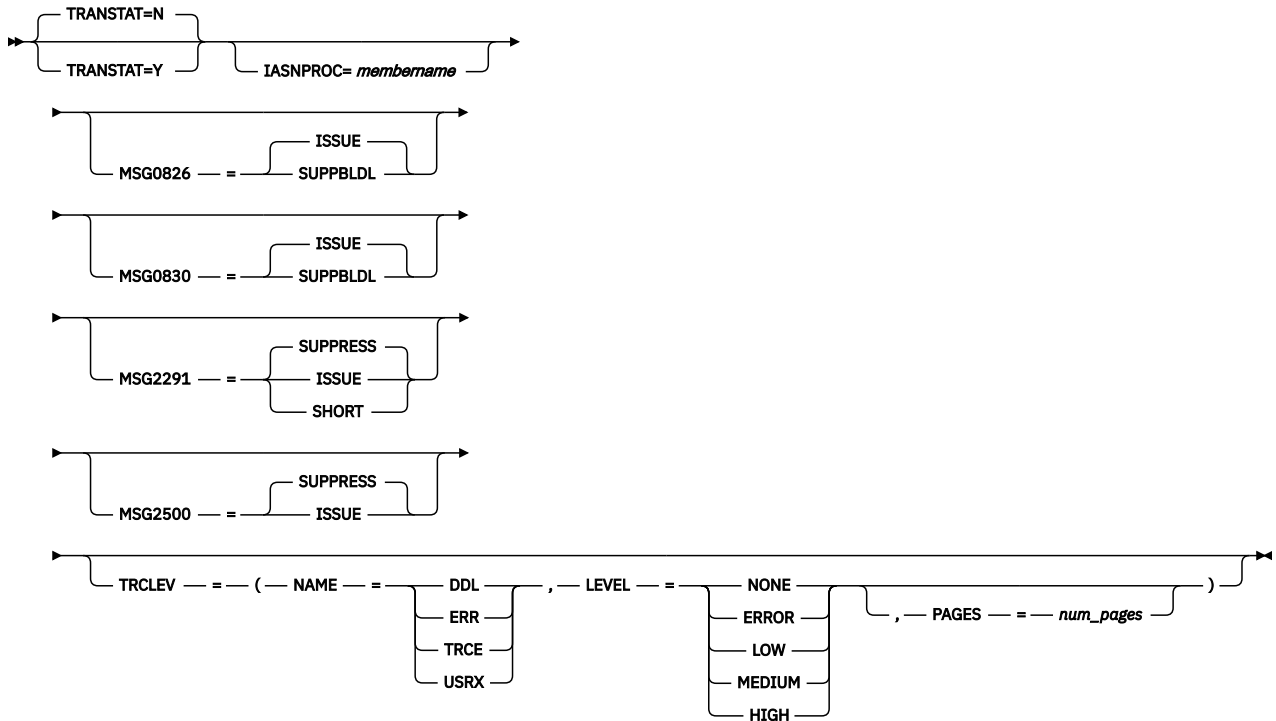

Parameters

IASNPROC=membername

Specifies a 1- to 8-character name of the IMS abend search and notification procedure. The IMS abend search and notification function is enabled only if the IASNPROC parameter is specified and defines a member name; otherwise, it is disabled.

MSG0826=

Specifies which forms of the DFS826I message are issued or suppressed.

ISSUE

All forms of the message can be issued. ISSUE is the default.

SUPPBLDL

Suppresses the following forms of the message:

- DFS826I BLDL FAILED FOR FOLLOWING DBDs
- DFS826I xxx DBD ERRORS SENT TO JOB LOG

The following message is issued to indicate how many failure messages were suppressed:
DFS826I xxx DBD ERRORS SUPPRESSED.

MSG0830=

Specifies which forms of the DFS830I message are issued or suppressed.

ISSUE

All forms of the message can be issued. ISSUE is the default.

SUPPBLDL

Suppresses the following forms of the message:

- DFS830I BLDL FAILED FOR FOLLOWING PSBs
- DFS830I xxx PSB ERRORS SENT TO JOB LOG

The following message is issued to indicate how many failure messages were suppressed:
DFS830I xxx PSB ERRORS SUPPRESSED.

MSG2291=

Specifies whether the DFS2291I message is issued or suppressed.

SUPPRESS

Suppresses the message DFS2291I from being issued by IMS. SUPPRESS is the default.

SHORT

IMS can issue one single segment message DFS2291I with information about the blocker only.

ISSUE

IMS can issue the message DFS2291I.

MSG2500=

Specifies whether the dynamic allocation and deallocation message DFS2500I is issued or suppressed when an **UPDATE DB** command is issued for HALDBs.

SUPPRESS

Suppresses dynamic allocation and deallocation message DFS2500I from being issued by IMS for HALDB partitions. SUPPRESS is the default.

ISSUE

IMS can issue the dynamic allocation and deallocation message DFS2500I for HALDB partitions.

TRANSTAT=

Specifies whether transaction level statistics are logged. If Y is specified, transaction level statistics are written to the log in an X'56FA' log record.

The value specified for this parameter is taken into consideration when IMS is cold started and transaction and program definitions are created from definitions contained in the MODBLKS data set or when creating new programs and transactions by using the **CREATE PGM** and **CREATE TRAN** commands and the TRANSTAT value for the new resource is obtained from the system default descriptor.

The TRANSTAT= parameter is ignored when transaction and program definitions are created from definitions imported from an RDDS or the IMSRSC repository.

N

Transaction-level statistics are not logged for all transactions and all programs. Transaction-level statistics can be logged for individual transactions or programs by defining the APPLCTN macro or TRANSACT macro with TRANSTAT=Y, or issuing an **UPDATE PGM** command or **UPDATE TRAN** command. N is the default.

Y

Transaction-level statistics are logged for all transactions and all programs, regardless of the transaction statistics value defined with the APPLCTN macro or TRANSACT macro. An **UPDATE PGM** command or **UPDATE TRAN** command can be issued to reset the TRANSTAT value to N for a particular transaction or program.

If dynamic resource definition (DRD) is enabled and resource definitions are imported from an RDDS or the IMSRSC repository during cold start, the **UPDATE TRAN NAME(*) SET(TRANSTAT(Y))** and **UPDATE PGM NAME(*) SET(TRANSTAT(Y))** commands can be used to turn on transaction level statistics for all programs and transactions once IMS is up. To ensure that the updated TRANSTAT values persist across a cold start, all resource and descriptor definitions should be exported to a system RDDS or the repository.

TRCLEV

Activates a type-2 trace table at IMS initialization. If a particular trace table is not specified with a TRCLEV parameter, the default values for that trace table are used.

NAME

Specifies the 1-4 character type-2 trace table name. Each trace table is specified with a 1-4 character name that refers to the type of events that are traced into that table. Valid trace table names are as follows:

DDL

The DDL trace table traces DDL events within IMS. The default trace level is NONE. The default number of pages is 8. The DDL trace table resides in extended common storage (ECSA).

ERR

The error trace table traces error events within IMS. The default trace level is HIGH. The default number of pages is 8. The ERR trace table resides in ECSA.

TRCE

The trace services trace table traces IMS trace services events. The default trace level is NONE. The default number of pages is 8. The TRCE trace table resides in ECSA.

USRX

The USRX trace table traces IMS User Exit services. The default trace level is NONE. The default number of pages is 6. The USRX trace table resides in ECSA.

All type-2 trace tables can be activated for the following environments:

- Batch
- DB/DC
- DBCTL
- DCCTL
- FDBR
- XRF alternate

If you attempt to activate a trace in an environment that does not support that trace type, IMS ignores the request.

LEVEL

Specifies the volume of tracing for this trace table. Each trace entry has an associated level. Each trace table has a level setting that is controlled by what is specified in the LEVEL parameter or the **UPDATE TRACE** command for the table.

A trace entry is written only if the trace entry level is less than or equal to the current level of the trace table. For example, if the trace entry is MEDIUM, the entry is only written if the trace table level is MEDIUM or HIGH. Thus, the specified level controls the volume (number) of trace entries that are written to a given table.

A level setting of LOW will result in fewer entries written to the trace table. This results in a smaller performance impact, but provides less detailed diagnostic information.

A level setting of HIGH will result in more entries being written to the trace table. This can result in a higher impact on CPU usage but will provide a higher level of diagnostic information.

Valid levels are as follows:

NONE

No trace entries are written

ERROR

Only trace entries for error conditions are written.

LOW

Low volume tracing.

MEDIUM

Medium volume tracing.

HIGH

High volume tracing.

The default trace level for type-2 trace tables is NONE, except for ERR trace tables, which is always set to a level of HIGH.

PAGES

An optional parameter that can be used to specify the number of 4 KB pages that are allocated for the trace table type. Specify a value in the range 1 - 32767 pages for this parameter. If you do not use this parameter, the default number of pages for the trace table type is allocated.

Specifying a larger number of pages allows more trace entries to be stored before the table wraps, if it is not being written out, or reduces the chances of entries being skipped, if the table is being written externally. However, the more pages that are requested, the more storage is used. If the table is allocated in ECSA, this setting can have an impact on ECSA usage. For a table that is allocated in ECSA, ensure that you have sufficient ECSA storage available on your system before you specify a large number for the **PAGES** parameter. This prevents serious system problems if you run out of ECSA.

Example of the DIAGNOSTICS_STATISTICS section of the DFSDFxxx member

```
/* **** */
/* DFSDFXXX MEMBER */
/* DIAGNOSTIC SECTION */
/* **** */
<SECTION=DIAGNOSTICS_STATISTICS>
IASNPROC=procname /* IMS abend search and notification PROCLIB member */
MSG2500=ISSUE /* Allow message DFS2500I for HALDB partitions */
/* **** */
/* */
/* **** */
```

In the following example, the DIAGNOSTICS_STATISTICS section is defined to enable the TRCE trace table with a level of LOW. The DDL trace table is also enabled with a level of HIGH and 30 pages allocated for the trace table.

```
/* **** */
/* DFSDFXXX MEMBER */
/* DIAGNOSTIC SECTION */
/* **** */
<SECTION=DIAGNOSTICS_STATISTICS>

TRCLEV=(NAME=TRCE, /* Type-2 trace services trace table */
        LEVEL=LOW) /* Low volume */

TRCLEV=(NAME=DDL, /* Type-2 DDL trace table */
        LEVEL=HIGH, /* High volume */
        PAGES=30) /* Allocate 30 pages for tables */
```

Related reference

“DFSIASNO procedure” on page 619

DFSIASNO is a sample procedure that invokes the IMS abend search and notification function, a diagnostic tool that you can customize so that you receive an informational email if an abend occurs.

DYNAMIC_RESOURCES section of the DFSDFxxx member

The DYNAMIC_RESOURCES section of the DFSDFxxx member specifies options for import and export, log write ahead, and system resource definition data sets. This section is processed only if DRD is enabled (MODBLKS=DYN). If DRD is not enabled, this section is ignored. The section is defined by the header <SECTION=DYNAMIC_RESOURCES>. The DYNAMIC_RESOURCES section is valid in DB/DC, DBCTL, and DCCTL environments.

Syntax

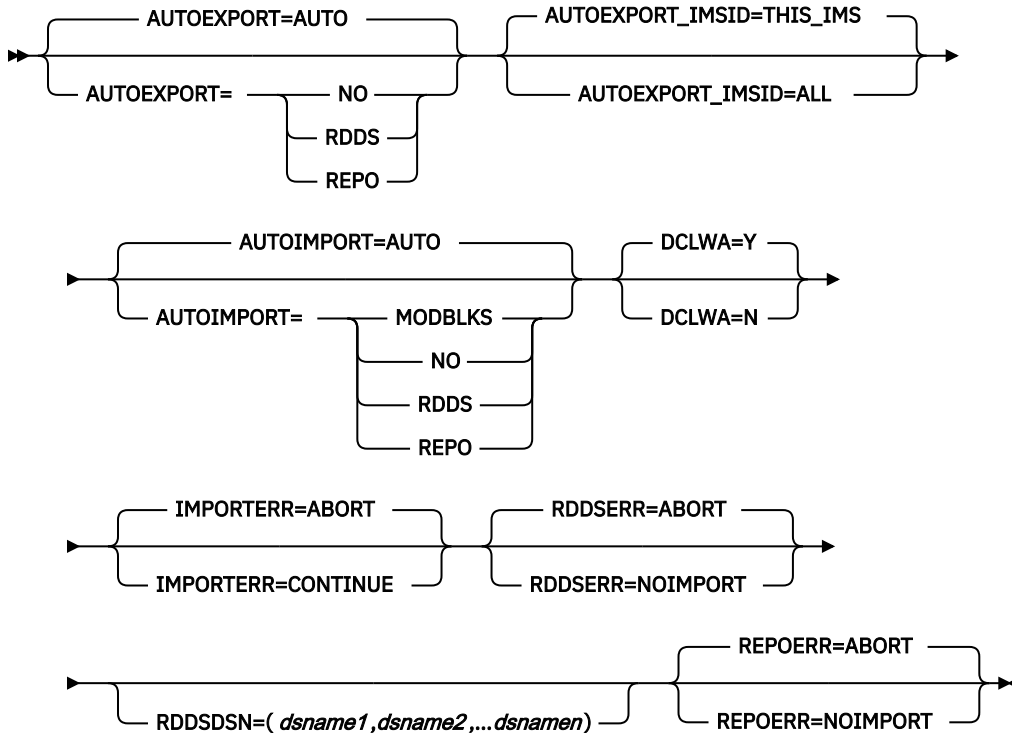

Parameters

These parameters are applicable only in a DRD environment; they are ignored in a non-DRD environment.

AUTOEXPORT=AUTO | NO | RDDS | REPO

Specifies whether all resource and descriptor definitions are exported at checkpoint time (simple or normal shutdown).

The automatic export takes place only if definitional changes were made to any resource since the time of the last checkpoint, except for restart checkpoint. After IMS completes restart processing, a restart checkpoint is taken. Export occurs after the restart checkpoint if automatic export is enabled.

AUTO

IMS determines whether to enable automatic export.

If **AUTOEXPORT=AUTO** is specified or defaulted to, automatic export is enabled to the system resource definition data set (RDDS) if two or more system RDDSs are defined and accessible.

If **AUTOEXPORT=AUTO** is explicitly specified in the DFSDFxxx PROCLIB member and IMS is enabled to use the IMSRSC repository, automatic export is also enabled to the IMSRSC repository.

If **AUTOEXPORT=AUTO** is defaulted to, automatic export to the repository is not enabled even if IMS is enabled with the repository.

If **AUTOEXPORT=AUTO** is specified in the DFSDFxxx PROCLIB member and both the repository and two or more system RDDSs are defined and accessible, automatic export is enabled to both the repository and the RDDS.

NO

Disables automatic export. No resource or descriptor definitions are exported at checkpoint time.

RDDS

Automatic export is enabled if two or more system resource definition data sets are defined and accessible. All resource and descriptor definitions are exported to the oldest system resource definition data set at checkpoint time.

REPO

IMS automatically exports resource definitions to the IMSRSC repository if IMS is enabled to use the repository. If IMS is not enabled with the IMSRSC repository, set `AUTOEXPORT=NO` to disable automatic export.

If `AUTOEXPORT=RDDS` is specified, IMS automatically exports to an RDDS if a valid system RDDS exists, even if the `REPOSITORY` section of the `DFSDFxxx` member is defined and IMS is enabled to use the repository. With this behavior, you can have a valid RDDS during a migration to the repository. After a successful migration to the repository, you can disable automatic export to an RDDS by using the **UPDATE IMS SET(LCLPARM(AUTOEXPORT(N)))** command.

AUTOEXPORT_IMSID=THIS_IMS | ALL

Specifies how automatic export processing should write the resource definitions to the IMSRSC repository and the IMS IDs for which the resource definitions are defined.

Note: `AUTOEXPORT_IMSID` applies only if automatic export is enabled to the IMSRSC repository. If the automatic export to the repository is not enabled, this parameter is ignored.

THIS_IMS

Writes the resource definitions from this IMS to the IMSRSC repository for the IMS system that is processing the automatic export. If the resource definition exists in the repository for the IMS system that is processing the automatic export, the definition is updated. If the resource definition does not exist in the repository for the IMS system that is processing the automatic export, it is created and the resource name is added to the IMS resource list of the IMS that is processing the automatic export. If there are multiple IMS systems in the IMSplex, each IMS creates or updates the resource definition for itself during its automatic export processing.

If `AUTOEXPORT_IMSID=THIS_IMS` is specified, only the resource definition changes to the specified IMS ID are exported. An X'22' log record is written by all IMS systems that initiated the automatic export.

After an automatic export to the repository with `AUTOEXPORT_IMSID=THIS_IMS`, the **QUERY XXX SHOW(DEFN)** command output will show a response line for each IMS until the automatic export from the last IMS that has the resource defined takes place. When RM processes the automatic export request from the last IMS that has the resource definition defined, RM internally analyzes the repository definition and merge any IMS definitions to optimize storage use in the repository.

After a successful automatic export to the repository from the last IMS that has the resources defined, there will not be any IMS specific response lines on the **QUERY XXX SHOW(DEFN)** commands if all the IMS systems have the same resource definitions.

If the resource definitions are not cloned in the IMSplex, use `AUTOEXPORT_IMSID=THIS_IMS`. This specification is equivalent to not specifying `SET(IMSID())` or specifying `SET(IMSID(imsid))` of the IMS system on the **EXPORT DEFN TARGET(REPO)** command. When the last IMS that has the resource defined does its automatic export, RM will compare the attribute definitions for all IMS systems and merge the resource definition into a generic definition to save space in the repository.

ALL

Writes the resource definitions from this IMS to the IMSRSC repository for all IMS systems that are defined to use the repository. If the resource definition exists in the repository, it is updated. If the resource definition does not exist in the repository, it is created and the resource name is added to the IMS resource lists for all the IMS systems that are defined to use the repository.

If `AUTOEXPORT_IMSID=ALL` is specified, automatic export is requested to the Resource Manager (RM) so that RM exports the resource definition changes to all the IMS IDs that have the resource defined. Only the IMS global resource definition in the repository is updated. An X'22' log record is written only at the IMS that initiated the automatic export. The resource definitions are still marked at other IMS systems as "export needed" even though the repository is updated, and they will be reset at the next checkpoint at the other IMS systems.

If the resource definitions are cloned, you can specify `AUTOEXPORT_IMSID=ALL`. This specification is equivalent to using `SET(IMSID(*))` on the **EXPORT DEFN TARGET(REPO)** command.

Note: In an MSC environment, when AUTOEXPORT_IMSID=ALL is specified, the autoexport to the IMSRSC repository will fail if there are any remote transactions or remote transaction descriptors in the list of resource definitions being exported to the repository. The **EXPORT DEFN TARGET (REPO)** command with the SET(IMSID(imsidlist)) can be used to write the remote transactions and remote transaction descriptors to the repository.

AUTOIMPORT=AUTO | MODBLKS | NO | RDDS | REPO

Specifies whether resource and descriptor definitions are automatically imported during IMS cold start.

The AUTOIMPORT= parameter applies only if dynamic resource definition is enabled.

If dynamic resource definition is enabled for both MODBLKS and MSC resources, the AUTOIMPORT= value applies to both MODBLKS and MSC resources.

If dynamic resource definition is enabled for MODBLKS resources but not for MSC resources, the value specified for the AUTOIMPORT= parameter applies only to the MODBLKS resources and is ignored for the MSC resources. The MSC resources that are generated during an IMS system definition are automatically imported instead.

If dynamic resource definition is disabled for both MODBLKS and MSC resources, the value specified for the AUTOIMPORT= parameter is ignored for both MODBLKS and MSC resources. The MODBLKS and MSC resources that are generated during an IMS system definition are automatically imported instead.

If AUTOIMPORT=AUTO is specified, these conditions determine the source of the imported resource and descriptor definitions:

If all of the following conditions are true, automatic import from the IMSRSC repository is enabled:

- For MODBLKS resources, MODBLKS=DYN is specified to enable MODBLKS DRD in IMS.
- For MSC resources, the MSC section of the DFSDFxxx member of the IMS PROCLIB data set is defined with MSCRSCS=DYN to enable MSC DRD in IMS.
- For MSC resources, the MSC section of the DFSDFxxx member is defined with MSCREPO=Y to enable MSC resources to be stored in the IMSRSC repository.
- The REPOSITORY section of the DFSDFxxx member is defined with TYPE=IMSRSC.
- IMS is enabled with RM services (RMENV=N is not specified in the DFSCGxxx member of the IMS PROCLIB data set or in the CSL section of the DFSDFxxx member of the IMS PROCLIB data set)
- The CSLRIxxx member of the IMS PROCLIB data set is defined for the repository with TYPE=IMSRSC.
- The repository contains stored resource definitions for the IMS system.
- RM is started with the repository enabled.
- The RS address space is started and available.

If all of the following conditions are true, automatic import from an RDDS is enabled:

- MODBLKS=DYN is specified to enable DRD in IMS.
- The REPOSITORY section of the DFSDFxxx member of the IMS PROCLIB data set is not present.
- Two or more system RDDSs are defined in the RDDSDSN() parameter of the DFSDFxxx member of the IMS PROCLIB data set.
- All of the defined RDDSs can be allocated and read.
- At least one of the RDDSs contains valid resource and descriptor definitions.

If all of the following conditions are true, automatic import from the MODBLKS data set is enabled:

- MODBLKS=DYN is specified to enable DRD in IMS.
- The REPOSITORY section of the DFSDFxxx member of the IMS PROCLIB data set is not present.

- No RDDs are defined in the DFSDFxxx member of the IMS PROCLIB data set, or all the defined RDDs are empty.
- The MODBLKS data set exists and is not empty.

If all of the following conditions are true, automatic import from the DFSCLL3x member of the IMS.SDFSRESL data set is enabled:

- The REPOSITORY section of the DFSDFxxx member of the IMS PROCLIB data set is not present or the repository does not contain any MSC resources.
- The DFSCLL3x member exists and is not empty.

In addition, only if no errors occur trying to access one or more of the data sets, automatic import is accomplished.

AUTO

IMS determines whether to enable automatic import processing. If IMS enables automatic import, it also determines the data source from which to import the definitions. AUTOIMPORT=AUTO is the default.

IMS chooses as a source for resource definitions the first data source type that it encounters that is enabled for automatic import. IMS searches data sources in the following order:

1. IMSRSC repository
2. RDDS
3. MODBLKS data set and the DFSCLL3x member of the IMS.SDFSRESL data set

If the repository does not contain the stored resource definitions for the IMS, then IMS attempts to read from the RDDS if it is defined and not empty. IMS issues the DFS4405W message if the repository is empty.

If the RDDS is empty, IMS reads from the MODBLKS data set and the DFSCLL3x member of the IMS.SDFSRESL data set if they are not empty. If the MODBLKS data set is empty, IMS comes up with no MODBLKS resources. If the IMS.SDFSRESL DFSCLL3x member does not exist, IMS comes up with no MSC resources.

If the IMS resource list in the repository is not empty, IMS processes the resource definitions returned by the Resource Manager (RM). IMS processes the stored resource definitions from the repository.

If there is an error processing the returned MODBLKS definitions, the action that is taken is based on the IMPORTERR= parameter setting. If IMPORTERR=CONTINUE, IMS marks the MODBLKS resources that are in error with a NOTINIT status and continues processing. If IMPORTERR=ABORT, automatic import processing is canceled, and IMS cold start terminates abnormally with a U3397 abend.

If there is an error reading from the repository, other than if the IMS resource list is not found, a DFS4401E message is issued with the RM return and reason code. Action is taken based on the REPOERR= parameter setting.

MODBLKS

Resource definitions are imported from the MODBLKS data set if one is defined. If definitions are imported from the MODBLKS data set, the values specified for the IMPORTERR=, RDDSERR=, and REPOERR= parameters do not apply and are ignored if specified. If an error occurs, IMS cold start is canceled.

NO

No resource or descriptor definitions are imported when IMS cold starts, if dynamic resource definition is enabled. If dynamic resource definition is not enabled, AUTOIMPORT=NO is ignored.

For MODBLKS resources, AUTOIMPORT=NO applies only if dynamic resource definition for MODBLKS resources is enabled; that is, if the DFSDFxxx <SECTION=COMMON_SERVICE_LAYER> is defined with MODBLKS=DYN. If AUTOIMPORT=NO is defined with MODBLKS=OLC or is defaulted to and MODBLKS resources that are generated from an IMS system definition exist,

IMS cold start automatically imports the MODBLKS resources that are generated from the system definition.

For MSC resources, AUTOIMPORT=NO applies only if dynamic resource definition for MSC resources is enabled; that is, if DFSDFxxx <SECTION=MSC> is defined with MSCRSCS=DYN. If AUTOIMPORT=NO is defined with MSCRSCS=NODYN or is defaulted to and MSC resources that are generated from an IMS system definition exist, IMS automatically imports the MSC resources that are generated from the system definition.

RDDS

Resource and descriptor definitions are imported from the most recently updated system resource definition data set (RDDS).

REPO

Stored resource and descriptor definitions are imported (automatic import) from the IMSRSC repository.

If AUTOIMPORT=REPO is specified, the CSLRIxxx member and the REPOSITORY section of the DFSDFxxx member must also be defined with TYPE=IMSRSC.

If the repository does not contain the stored resource definitions for the IMS, then IMS comes up with no resources. IMS issues the DFS4404I message if the repository is empty.

If the IMS resource list in the repository is not empty, IMS processes the resource definitions returned by the RM.

If there is an error processing the returned MODBLKS definitions, the action that is taken is based on the IMPORTERR= parameter setting. If IMPORTERR=CONTINUE, IMS marks the MODBLKS resources that are in error with a NOTINIT status and continues processing. If IMPORTERR=ABORT, automatic import processing is canceled, and IMS cold start terminates abnormally with a U3397 abend.

If there is an error reading from the repository, other than if the IMS resource list is not found, a DFS4401E message is issued with the RM return and reason code. Action is taken based on the REPOERR= parameter setting.

If AUTOIMPORT=REPO is specified and no REPOSITORY section is defined, or the REPOSITORY= statement for the repository is not defined, the DFS4403E message is issued. IMS initialization abends with U0071 with return code X'27'. The DFS2930 message is issued with completion code 27,2108 before the abend.

If AUTOIMPORT=REPO is specified and RMENV=N is specified in the CSL section, IMS initialization abends with U0071 with return code X'27', because IMS cannot access the repository for the stored resource definitions. IMS requires the CSL RM address space to access the repository. The DFS2930 message is issued with completion code 27,210C before the abend.

DCLWA=Y | N

Specifies the default log write ahead option for transactions that are defined with the CREATE TRAN command. DCLWA= specifies whether (Y) or not (N) IMS performs log write-ahead for recoverable nonresponse-mode input messages and transaction output messages. The default is Y. The IMS transaction descriptor DFSDSTR1 is defined with the DCLWA value that was defined in this DFSDFxxx member of the IMS PROCLIB data set. Any subsequent CREATE TRAN commands that are issued either without the LIKE keyword, or with LIKE(DESC(DFSDSTR1)), are defined with this DCLWA value.

Y

Specifies that:

- Information in the log buffers is written to the IMS log before the associated input acknowledgment or output reply is sent to the terminal.
- A nonresponse-input transaction is made recoverable across IMS failures before IMS acknowledges receipt of the input.
- Database changes are made recoverable before IMS sends associated output reply messages.

N

Specifies that input message integrity and the consistency of output messages with associated database updates is not required. DCLWA does not apply to response mode or Fast Path input processing. If it is specified in these situations, is ignored during IMS execution.

IMPORTERR=ABORT | CONTINUE

Specifies which action to take if an error occurs during automatic import processing due to an invalid resource or descriptor definition. This parameter does not pertain to errors that occur while trying to access an RDDS; use the RDDSERR= parameter to choose processing options following RDDS-related errors.

ABORT

Automatic import processing is canceled, and IMS cold start terminates abnormally with a U3397 abend. ABORT is the default.

CONTINUE

Automatic import processing continues. The resource in error is marked and given a not-initiated status (NOTINIT). If the resource is required, create or update the resource after cold start completes.

This value does not apply for MSC resources. If an error occurs during the automatic import of MSC resources, automatic import processing is canceled as if IMPORTERR=ABORT were specified.

RDDSERR=ABORT | NOIMPORT

Specifies which action to take if an error occurs when a resource definition data set is accessed during automatic import processing.

ABORT

Automatic import processing is canceled, and IMS cold start terminates abnormally with a U3368 abend. ABORT is the default.

NOIMPORT

Automatic import processing is canceled. The IMS system is started with no database resources or descriptors (DDIRs), program resources or descriptors (PDIRs), routing code resources or descriptors (RCTEs), or transaction resources or descriptors (SMBs) defined.

RDDSDSN=(dsname1, dsname2,...dsnamen)

Specifies the 1- to 44-character names of the system resource definition data sets. The data sets must be cataloged BSAM data sets. The data sets are dynamically allocated and opened in the order in which they are specified on the RDDSDSN= parm. Each IMS in the IMSplex must have its own set of system resource definition data sets. At least two data set names must be specified. Although any number of data sets can be specified, three RDDSs are recommended. When exporting to a system RDDS, IMS alternates exporting between each of the data sets specified. All resource and descriptor definitions for the local IMS are exported to the oldest data set specified on the RDDSDSN= parameter. When importing from a system RDDS, IMS uses the RDDS with the most current data.

IMS always attempts to write to the RDDS containing the oldest data. If a failure occurs while IMS attempts to write to the data set with the oldest data, the data set with the next oldest data is selected. The RDDS with the most current data is preserved. For example, if two RDDS data sets are defined, and RDDS1 contains the most current resource and descriptor definitions, automatic export attempts to write to RDDS2 first. If that fails, automatic export does not attempt to write to RDDS1. The automatic export function is suspended until the error is resolved.

When creating and allocating the RDDS data sets, be sure to place an end-of-file (EOF) mark at the beginning of the data set. Otherwise, unpredictable results can occur. To ensure that an EOF mark is placed at the beginning of the data set, program IEBGENER can be used with a DUMMY SYSUT1 DD statement that contains the parameters BLKSIZE=xxxxx and RECFM=VB, where xxxxx is a value 4096 - 32760, inclusive. The SYSUT2 DD statement:

- Points to the DSN and VOLSER of the RDDS to be created.
- Specifies LRECL=yyyyy, BLKSIZE=xxxxx, and RECFM=VB, where xxxxx is the value of the block size specified on the DUMMY SYSUT1 DD statement, and yyyyy is (xxxxx - 4).

Recommendation: Set BLKSIZE to 32760.

The RDDSDSN parameter is not required if IMS is defined to use the IMSRSC repository and the repository contains the stored resource definitions for the IMS. If the RDDSDSN= parameter is specified, the RDDSDSN data sets specified is allocated and initialized during IMS initialization.

If AUTOEXPORT=RDDS is specified, an RDDSDSN is used for automatic export processing. If the RDDSDSNs are defined, automatic export to RDDSDSN at system checkpoint is enabled, even if IMS is defined to use the repository.

REPOERR=ABORT | NOIMPORT

Specifies the action to perform if there are errors importing data from an IMSRSC repository that are not due to invalid or missing resource or descriptor definitions. A DFS4401E message is issued with the Resource Manager (RM) request return and reason code.

If there are errors importing data from a repository that are due to invalid or missing resource or descriptor definitions, the IMPORTERR= parameter determines the action to perform.

ABORT

Cancel the IMS cold start if there are errors importing data from a repository. ABORT is the default.

NOIMPORT

Continue the IMS cold start with no resources imported from a repository.

Example of the DYNAMIC_RESOURCES section of the DFSDFxxx member

```
/* **** */
/* * Dynamic Resource Definition Section */
/* **** */
<SECTION=DYNAMIC_RESOURCES>
RDDSDSN=(IMSTESTL.IMS1.RDDS1,
          IMSTESTL.IMS1.RDDS2,
          IMSTESTL.IMS1.RDDS3,)
AUTOIMPORT=AUTO
AUTOEXPORT=AUTO
IMPORTERR=ABORT
RDDSER=ABORT
/* **** */
```

Related concepts

[“Overview of the IMSRSC repository” on page 37](#)

A repository is a generalized data storage facility that can be used to store any type of information. The IMS resource definition (IMSRSC) repository is a set of VSAM key sequenced data sets (KSDSs) used for storing information. The IMSRSC repository is a repository to store resource (and descriptor) definitions for IMS databases, transactions, programs, and routing codes. This repository is an alternative to the resource definition data set (RDDSDSN) that is used with the dynamic resource definition (DRD) function.

Related tasks

[“Importing MODBLKS resource and descriptor definitions by using the automatic import function” on page 85](#)

With dynamic resource definition (DRD) enabled, you can enable the automatic import function so that MODBLKS resource and descriptor definitions are imported to IMS during IMS cold start processing.

[“Defining the IMSRSC repository” on page 40](#)

Before you can use the IMSRSC repository to store and retrieve resource and descriptor definitions, you must define it. In addition, IMS and the Resource Manager (RM) must have the repository enabled, the Repository Server (RS) must be started and active, and the repository must be started.

Related information

[DFS4405W \(Messages and Codes\)](#)

[DFS4401E \(Messages and Codes\)](#)

[DFS4404I \(Messages and Codes\)](#)

[DFS4403E \(Messages and Codes\)](#)

FASTPATH section of the DFSDFxxx member

The FASTPATH section of the DFSDFxxx member specifies options for Fast Path, such as the use of the Fast Path 64-bit buffer manager. The section must begin with the header <SECTION=FASTPATH>. The FASTPATH section is valid in DB/DC and DBCTL environments.

Syntax

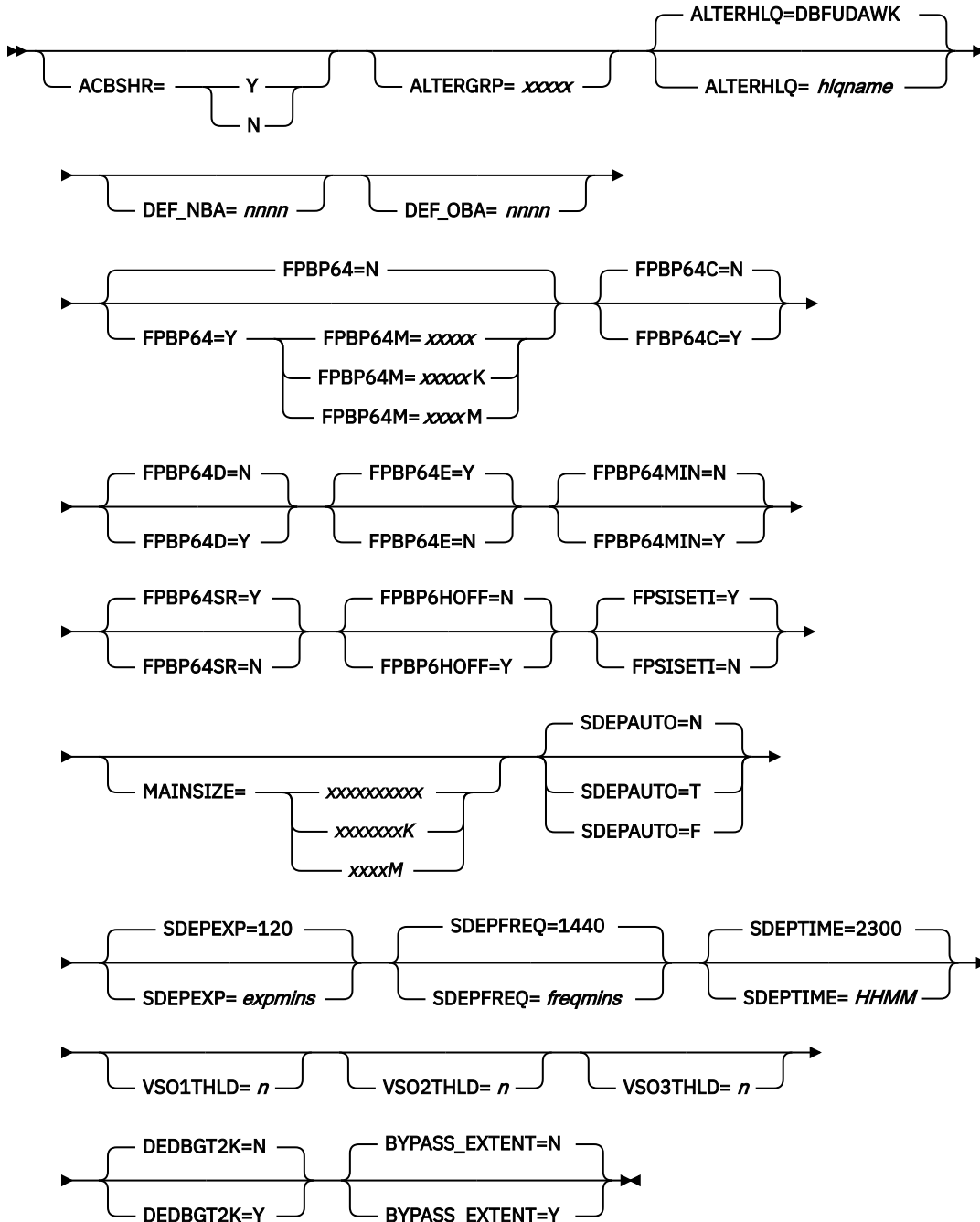

Parameters

ACBSHR=

Specifies whether the ACB libraries are shared among the IMS systems when the DEDB Alter Utility runs. This parameter can be specified in both the DFSCGxxx and DFSDFxxx members of the IMS

PROCLIB data set. If it is specified in both members, IMS uses the ACBSHR value that is specified in the DFSCGxxx member of the IMS PROCLIB data set.

Y

Specifies that all the IMS systems use the same ACB library.

N

Specifies that each IMS uses its own dedicated ACB library.

Each IMS system must have the same value for ACBSHR=. If the ACBSHR= values are not the same, the DEDB Alter utility terminates without performing the requested function.

You can also specify ACBSHR in the COMMON_SERVICE_LAYER section of the DFSDfxxx member. When this parameter is used multiple times, the following describes the order of preference for ACBSHR=Y|N value:

1. DFSCGxxx PROCLIB member: ACBSHR=Y|N value
2. DFSDfxxx PROCLIB member <SECTION=COMMON_SERVICE_LAYER>: ACBSHR=Y|N value
3. Default ACBSHR=Y for Common Service Layer if ACBSHR=Y|N not specified in 1st and 2nd.
4. DFSDfxxx PROCLIB member <SECTION=FASTPATH>: ACBSHR=Y|N value
5. Default ACBSHR=Y for <SECTION=FASTPATH> if not specified in 4th.

ALTERGRP=

Specifies the 1- to 5-character alphanumeric name for the DEDB Alter data-sharing group. If an IMS is to participate in a DEDB Alter process, ALTERGRP= must be specified in the DFSDfxxx PROCLIB member for each data sharing IMS system.

ALTERGRP= contains 1 - 5 alphanumeric characters that are prefixed by DBF. The DEDB Alter data sharing group that data sharing IMS systems join is DBFxxxxx. There is no default value for ALTERGRP=xxxxx.

ALTERHLQ=

Specifies the 1- to 8-character alphanumeric name for the high-level qualifier of temporary data sets for the DEDB Alter utility. ALTERHLQ=DBFUDAWK is the default.

BYPASS_EXTENT=N | Y

In IMS 15, a bypass extent check enhancement for DEDB data sets is added to the available Fast Path options. When enabled, this enhancement specifies that normal extent checking will be suspended while data is being written.

Enabling this option could result in improved performance in certain cases when multiple applications are simultaneously reading or writing the same disk extent ranges. For example, users of HSSP or HSRE with a Metro Mirror configuration may benefit from use of this feature.

Normally, when your program writes on DASD, the DASD subsystem performs extent serialization that prevents all access to that extent from all other programs on all systems while data is being written. This prevents other programs from reading and writing within the extent and from seeing certain types of incomplete updates. But if bypass extent check is enabled by coding BYPASS_EXTENT=Y in the FASTPATH section of the DFSDfxxx member, the DASD subsystem will serialize access to only one track at a time, not to the whole extent.

If you know that other programs might be reading the data set at the same time that your program is writing and that a mechanism exists within those other programs to avoid or tolerate potentially incomplete updates within an extent, then enabling bypass extent check could provide improved performance due to normal extent serialization being suspended.

It is acceptable to have bypass extent check enabled on one IMS and disabled on the other(s), but the bypass extent check option will not become active until it is enabled on all systems.

When enabled, bypass extent check will function for all supported DEDB CI sizes except for:

- **3380 DASD:** 12 KB, 16 KB, 24 KB, and 28 KB
- **3390 DASD:** 20 KB and 28 KB

N

Specifies that bypass extent check is not enabled. When IMS starts, message DFS1919I is displayed for BYPASS_EXTENT = N in the DFSDF member. This is the default.

Y

Specifies that bypass extent check is enabled. When IMS starts, message DFS1919I is displayed for BYPASS_EXTENT = Y in the DFSDF member.

DEDBGT2K=N | Y

Y

Specifies that this IMS opens more than 2048 areas under one DEDB. When IMS starts, message DFS1929I is displayed for DEDBGT2K in the DFSDF member or the default value of DEDBGT2K=N.

N

Specifies that this IMS does not open more than 2048 areas under one DEDB. This is the default.

DEF_NBA=

Specifies the default NBA number to override the NBA= parameter of a BMP procedure. A valid range is 0 - 9999. This value is valid only when FPBP64=Y is specified. If FPBP64=N, then the DFS4787I message is issued. When an invalid value is specified, BPE0003E shows the invalid value and the default value 0 is set in DEF_NBA. In this case, you need to specify a valid value, and you must restart IMS or specify the values for NBA= and OBA= to the BMP procedure.

DEF_OBA=

Specifies the default OBA number to override the OBA= parameter of a BMP procedure. A valid range is 0 - 9999. This value is valid only when FPBP64=Y is specified. If FPBP64=N, then the DFS4787I message is issued. When an invalid value is specified, BPE0003E shows the invalid value, and the default value 0 is set in DEF_OBA. In this case, you must specify a valid value, and you must restart IMS or specify values for NBA= and OBA= to the BMP procedure.

FPBP64=N | Y

Specifies whether to enable the Fast Path 64-bit buffer manager. If you choose to use the Fast Path 64-bit buffer manager (FPBP64=Y), the DBBF, DBFX, and BSIZ parameters that define Fast Path buffers are ignored. If you specify FPBP64=N, Fast Path buffer management is defined by the DBBF, DBFX, and BSIZ parameters on the startup procedure. FPBP64=N is the default.

If Fast Database Recovery (FDBR) is being used, and the Fast Path 64-bit buffer manager is enabled, you must specify the DFSDF= parameter to reference this DFSDFxxx member on the FDR procedure. This action ensures that the same Fast Path 64-bit buffer manager is used by both IMS and FDBR.

Important: If you change the FASTPATH section of the DFSDFxxx member, you must perform a cold start of the system. If you perform a normal start instead, message DFS0168I RSN=1B and ABENDU0168 are issued. The FPSISETI parameter may be changed with a warm start.

FPBP64M=

Use this parameter to set a maximum limit on how much 64-bit storage the Fast Path 64-bit buffer pool uses for DEDB data buffers. If FPBP64=Y is specified, this parameter is required. If FPBP64=N is not specified, FPBP64M is ignored.

The value is specified as a decimal value, in bytes, kilobytes, or megabytes, where:

xxxxx

Bytes. Maximum value is 2147483647.

xxxxxK

Kilobytes. Maximum value is 2097151K.

xxxxxM

Megabytes. Maximum value is 2047M.

The valid range is 1M - 2047M. The minimum value for this parameter is the amount of 64-bit storage that is initially allocated for the subpools (without any extents).

Once the specified limit is exceeded, it disallows the schedule of new threads. Currently, active threads are unaffected and can force the limit past the threshold that is established by FPBP64M. In

other words, if the amount of required 64-bit storage is greater than the value specified for FPBP64M, FPBP64M is increased and a DFS3299I message is issued.

The value for this parameter can be updated with the UPDATE POOL TYPE(FPBP64) SET(LIMIT(xxxxx)) command.

FPBP64C=N | Y

Specifies whether the Fast Path 64-bit buffer manager releases buffer storage when the number of buffers is reduced. FPBP64C=N is the default. If you specify FPBP64C=Y, the buffer manager increases and decreases the number of buffers as needed, but does not release the buffer storage when the number of buffers decreases.

FPBP64D=N | Y

Directs IMS (Y) or tells IMS not (N) to use values on the DBBF parameter to calculate the initial startup sizes for the 64-bit subpools. FPBP64D=N is the default. If you specify FPBP64D=Y, IMS sets the initial total number of buffers for the 64-bit subpools to 25 percent of the value specified on the DBBF parameter and distributes these buffers among all the CI sizes according to an internal algorithm.

For example, if you specify DBBF=4000 and FPBP64D=Y, IMS sets the initial total number of Fast Path buffers to 1000 and distributes them to the subpools.

Each 64-bit subpool must be a minimum of 32 buffers (for a 512-byte buffer - X'200') or 16 buffers for all other sizes.

FPBP64E=N | Y

Specifies whether the Fast Path 64-bit buffer manager increases the number of Fast Path buffers automatically based on an internal buffer-usage monitoring algorithm. FPBP64E=N is the default. If you specify FPBP64E=Y, the number of buffers is increased only when a request for a buffer is received and no buffers are available to satisfy that request.

FPBP64MIN=N | Y

Specifies whether the Fast Path 64-bit buffer manager allocates the subpools using the internal algorithm (FPBP64MIN=N) or allocates a subpool with minimum sizes (FPBP64MIN=Y) that vary between 8 and 32 buffers per subpool. FPBP64MIN=N is the default.

FPBP64SR=Y | N

Specifies whether the Fast Path 64-bit buffer manager moves SDEP insert buffers into 64-bit storage during **/ERESTART** command processing and Extended Recovery Facility (XRF) and FDBR tracking. FPBP64SR=Y is the default. When FPBP64SR=N is specified, IMS uses ECSA for SDEP insert buffers during **/ERESTART** command processing and Extended Recovery Facility (XRF) and FDBR tracking.

FPBP6HOFF=N | Y

Specifies whether the 64-bit **/ERE** code is enabled for the 64-bit High Speed Sequential Processing (HSSP) and High Speed Reorganization (HSRE) utilities. When FPBP6HOFF=Y is specified, the 64-bit **/ERE** code is disabled, IMS uses the pre-existing 31-bit private utility buffers to continue the processing during an emergency restart.

FPSISETI=Y | N

Specifies whether to prevent the Fast Path secondary index database maintenance, which you specify by using the SETI psb=*psbname* statement. FPSISETI=Y is the default.

Y

Specifies that the SETI PSB=*psbname* parameter on the //DFSCTL DD statement takes effect. Index database maintenance can be performed for the DEDB database.

N

Specifies that SETI PSB=*psbname* parameter on the //DFSCTL DD statement does not take effect. Index database maintenance cannot be performed for the DEDB database.

See “Set Index Maintenance Off (SETI) control statement” on page 968 for more information on the SETI control statement.

MAINSIZE=

Overrides the DFSORT default option for storage to be allocated.

The value is specified as a decimal value, in bytes, kilobytes, or megabytes, where:

XXXXXXXXXX

Bytes. Maximum value is 2097152000.

XXXXXXXXK

Kilobytes. Maximum value is 2048000K.

XXXXM

Megabytes. Maximum value is 2000M.

There is no default value for MAINSIZE=.

SDEPAUTO=N | F | T

Specifies whether the Automatic SDEP Buffer Management feature is enabled.

N

Specifies that the feature is disabled.

F

Specifies that the SDEPFREQ parameter is used to determine when processing is started.

T

Specifies that the SDEPTIME parameter is used to determine when processing is started.

When this parameter is omitted, Automatic SDEP Buffer Management is disabled, and the default is SDEPAUTO=N. If an invalid option is specified, the default is taken.

If there is an error in a parameter that occurs earlier in the FASTPATH section, it might cause SDEPAUTO to take the default value even if it is specified.

SDEPEXP=

Specifies the maximum age in minutes of pre-allocated SDEP CIs. The default age is 120 minutes. The minimum age is 60 minutes, and the maximum age is 65,535 minutes. If an invalid age is specified, the default is taken.

If there is an error in a parameter that occurs earlier in the FASTPATH section, it might cause SDEPEXP to take the default value even if it is specified.

SDEPFREQ=

Specifies the number of minutes between checks for expired SDEP CIs. This is only valid for SDEPAUTO=F and is ignored for SDEPAUTO=T. The default is 1440 minutes. The minimum frequency is 60 minutes, and the maximum frequency is 65,535 minutes. If an invalid frequency is specified, the default is taken.

If there is an error in a parameter that occurs earlier in the FASTPATH section, it might cause SDEPFREQ to take the default value even if it is specified.

SDEPTIME=

Specifies the local time of day in 24-hour format to check for expired SDEP CIs. The default is 2300. This is only valid for SDEPAUTO=T and is ignored for SDEPAUTO=F. The valid range for hours is 00 - 23, and the valid range for minutes is 00 - 59. If an invalid time is specified, the default is taken.

If there is an error in a parameter that occurs earlier in the FASTPATH section, it might cause SDEPTIME to take the default value even if it is specified.

VS01THLD=

Specifies the castout threshold time in seconds for a VSO area with less than or equal to 800 control intervals (CIs). The valid range is 1 - 300. The default value is 300.

VS02THLD=

Specifies the castout threshold time in seconds for a VSO area with 801 - 3500 CIs. The valid range is 1 - 300. The default value is 240.

VS03THLD=

Specifies the castout threshold time in seconds for a VSO area with greater than 3500 CIs. The valid range is 1 - 300. The default value is 180.

Example of the FASTPATH section of the DFSDFxxx member

```
/* **** */
/* Fast Path Section */
/* **** */
<SECTION=FASTPATH>
FPBP64=Y /* Fast Path 64-bit buffer manager */
FPBP64M=2047M /* FP 64-bit buffer pool max limit */
SDEPAUTO=F /* Automatic SDEP Buffer Management */
SDEPEXP=60 /* Max age of pre-allocated SDEP CIs */
SDEPFREQ=120 /* Minutes between checks for expired SDEP CIs */
/* **** */
/* */
/* **** */
```

Related concepts

[Overview of dynamic database buffer pools \(Database Administration\)](#)

Related reference

[UPDATE POOL command \(Commands\)](#)

LOGGER section of the DFSDFxxx member

The LOGGER section of the DFSDFxxx member specifies processing options for the IMS Logger. The section must begin with the header <SECTION=LOGGER>. The LOGGER section is a mandatory section.

Syntax

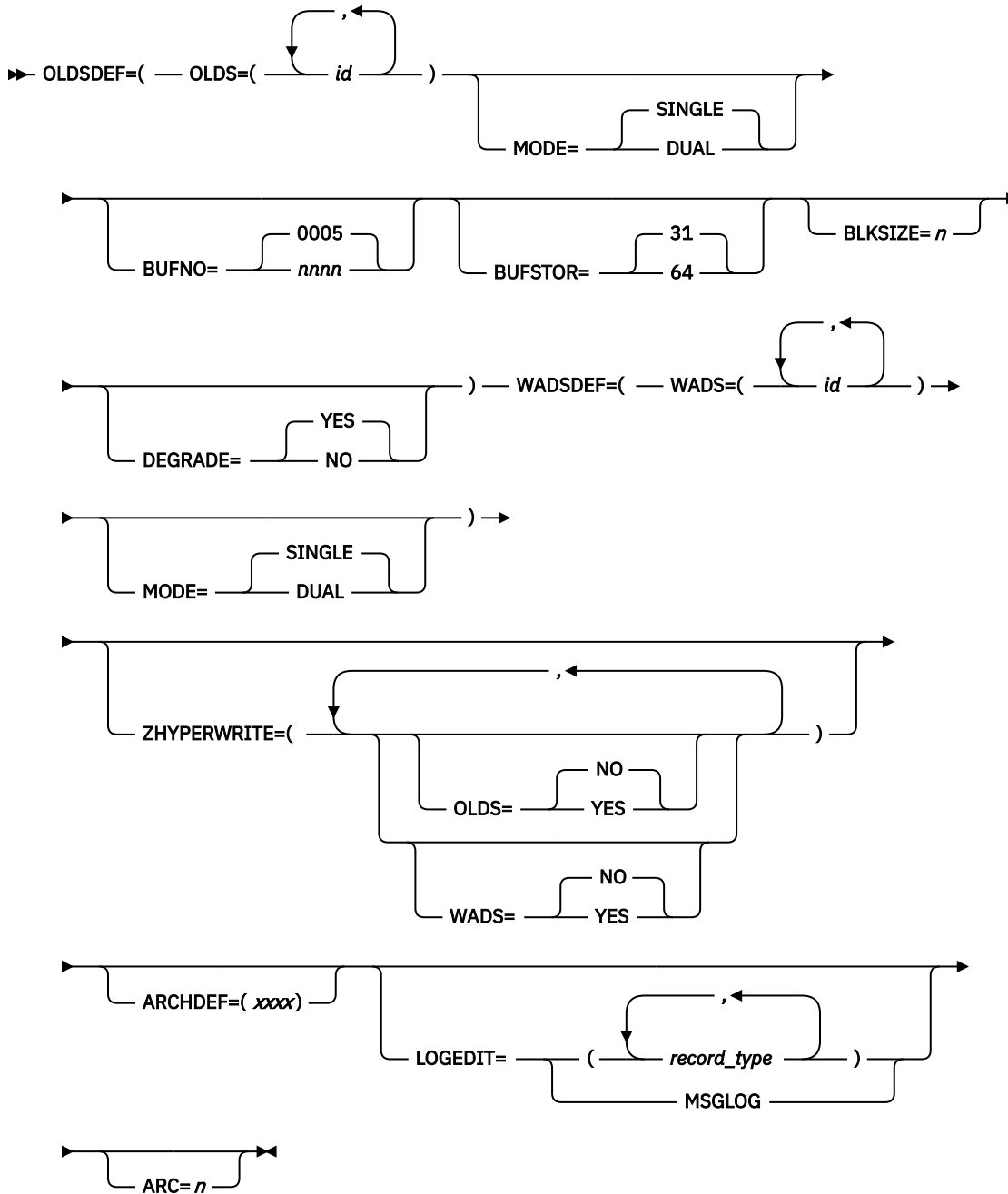

Parameters

OLDSDEF=()

Defines the OLDS to be established during initialization along with some processing options. Only one OLDSDEF statement is allowed. Keywords are delimited from the associated parameters by an equal sign (=), and the keyword/parameter pairs are delimited by commas (,) or spaces ().

OLDS=

Identifies 3 - 100 OLDS to be allocated during initialization, where *id* indicates a list of one or two-digit OLDS IDs, 0 - 99. You must specify at least three OLDSs.

BUFNO=

Identifies the number of log buffers allocated for OLDS read and write operations, where *nnnn* is a one- to four-digit numeric integer, 0002 - 9999. The default is 0005.

MODE=SINGLE | DUAL

Identifies whether the logger operates in SINGLE or DUAL logging mode. The default is SINGLE.

DEGRADE=

Identifies whether to degrade to single-logging mode (DEGRADE=YES), or to terminate IMS (DEGRADE=NO) after an OLDS write error occurs and there are fewer than three pairs of available OLDSs. Also, if one of the OLDSs in the pair to be used next encountered an error during preopen and DEGRADE=YES was specified, that pair is used in degraded mode. However, after it is switched, the pair will be stopped. If there are fewer than three good pairs of OLDSs, the pair will not be stopped and will continue to be used in degraded mode. The default is DEGRADE=YES.

BUFSTOR=

Specifies whether to obtain 31-bit or 64-bit virtual storage for OLDS log buffers. The default value is 31.

Recommendation: If you run IMS with 64-bit log buffers, back your log buffers by large (1 MB) pages, so that IMS can improve performance, due to more efficient dynamic address translation.

To set up your system to have large pages available, you must specify the LFAREA= parameter in the z/OS IEASYSxx PARMLIB member. Make sure that you request enough storage on LFAREA= to contain all of your log buffers, plus any other large page usage in your system.

To determine the amount that is required for your IMS log buffers, multiply the number of buffers you specified with the BUFNO= parameter by the OLDS block size, and round up to the next MB (1 MB = 1,048,576 bytes).

See the *z/OS MVS Initialization and Tuning Guide* for information about the IEASYSxx LFAREA= parameter.

Restriction:

IMS obtains log buffers in 64-bit virtual storage only when the OLDS block size is a multiple of 4096 even if BUFSTOR=64 is specified.

If the OLDS is not allocated as a DFSFMS extended-format data set, IMS issues message DFS0413I with response code 52 for every non extended-format OLDS discarded by IMS in a BUFSTOR=64 environment. IMS issues abend code 0616 if no OLDS satisfies all the BUFSTOR=64 restrictions.

BLKSIZE=

Specifies the log buffer block size. This parameter can be any multiple of 2048 (6144 - 30720 for 31-bit virtual storage) or any multiple of 4096 (for 64-bit virtual storage). The value that is specified with this parameter overrides any other value associated with any OLDS.

You can change the OLDS block size across either a cold start or a warm restart of IMS. However, if you change the size across a warm restart, you must follow the steps:

1. Shut down IMS normally.
2. Archive all OLDS.
3. Delete PRIOLDS and SECOLDS records from the RECON data sets by using the Database Recovery Control utility program (DSPURX00) **DELETE . LOG** command.
4. Change the BLKSIZE= parameter in the DFSDFxxx member to the new block size.
5. Verify WADS space allocation.

6. Restart IMS (from SLDS).

Changing the OLDS block size can affect the space required for the IMS Write Ahead Data Set (WADS). For example, if you have your WADS sized to hold 100 22-KB buffers, and you increase the OLDS block size to 24 KB, you must increase the size of the WADS if you want it to be able to hold 100 of the larger 24-KB buffers. If you reallocate the WADS, make sure that you restart IMS by using the **/NRESTART FORMAT WA** or **/NRESTART FORMAT ALL** command.

Provide dynamic allocation members (through the DFSMDA macro) for all OLDS data sets. All (primary and secondary) OLDS must be preallocated. You must specify the OLDS block size when the data set is allocated.

WADSDEF=()

Defines the WADS data sets to be established during initialization along with some processing options. Only one WADSDEF statement is allowed. Keywords are delimited from the associated parameters by an equal sign (=), and the keyword/parameter pairs are delimited by commas (,) or spaces ().

WADS=

Identifies a list of WADS to be allocated during IMS Logger initialization, where *n* indicates a list of one-digit WADS IDs, 0 - 9. You can specify 1 - 10 WADS IDs. A minimum of one WADS ID is required.

MODE=SINGLE | DUAL

Identifies whether the logger operates in SINGLE or DUAL logging mode. The default is SINGLE. This parameter cannot be changed at emergency restart.

Specifications of the former WADS= parameter in the DFSPBxxx PROCLIB member and in an EXEC statement in the control region JCL are ignored and not reported in the error log.

Provide dynamic allocation members (by using the DFSMDA macro) for all WADS data sets. All primary and secondary WADS must be preallocated.

ZHYPERWRITE=()

Optional parameter that specifies the use of zHyperWrite when IMS writes to the OLDS and the WADS.

OLDS=YES | NO

Specifies whether IMS uses zHyperWrite to write to the OLDS. The default is NO.

WADS=YES | NO

Specifies whether IMS uses zHyperWrite to write to the WADS. The default is NO.

ARCHDEF=(aaaa)

When IMS automatically archives OLDS in response to the ARC= parameter of the IMS procedure, it does so by internally issuing a **GENJCL . ARCHIVE** command to DBRC. The following command is the default:

```
GENJCL.ARCHIVE ALL SSID (xxxx)
```

Use the ARCHDEF control statement to change this command to:

```
GENJCL.ARCHIVE aaaa SSID (xxxx)
```

In this statement, *aaaa* represents any valid GENJCL parameter up to 61 characters in length.

See [GENJCL.ARCHIVE command \(Commands\)](#) for the valid parameters that you can put in ARCHDEF=(aaaa).

LOGEDIT=

Optional parameter that specifies the IMS log record types that are passed to the Log Edit user exit (LOGEDIT). Each instance of the parameter can be either of the following options:

record_type

Supported values are 01, 03, 4002, 5901, and 5903. You can specify multiple record types.

MSGLOG

Specify MSGLOG to pass all supported record types to the exit.

Any other value is ignored. If more than one LOGEDIT statement is supplied, the last one is used.

ARC=n

Optional parameter that specifies whether automatic archiving of the OLDS is to be performed. Valid values are 00 - 99. The default is 01. You can specify ARC=0 for no automatic archiving; otherwise, specify a one- or two-digit number representing the number of full (closed) OLDSs that invoke automatic archiving for those data sets. Automatic archiving is recommended; however, you can arrange for the MTO to monitor the availability of the OLDS and perform archiving when necessary.

ARC= also indicates the number of OLDSs to be filled before issuing the **DBRC GENJCL ARCHIVE** command. A **/DBRECOVERY** command can cause automatic archiving, even if the number specified in ARC= is not reached.

Example of the LOGGER section

```
<SECTION=LOGGER>
  OLDSDEF=(MODE=DUAL,
           OLDS=(00,01,02,03),
           BUFNO=10,
           BUFSTOR=64,
           BLKSIZE=24576)
  WADSDEF=(MODE=SINGLE,
           WADS=(0,1))
  ARCHDEF=(MEMBER(ARCHDSHR) ALL)
  LOGEDIT=(01)
```

Related concepts

[Allocating log data sets \(System Definition\)](#)

Related reference

[LOGEDIT: Log edit user exit \(DFSFLGEO and other LOGEDIT exits\) \(Exit Routines\)](#)

MSC section of the DFSDFxxx member

The MSC section of the DFSDFxxx member of the IMS PROCLIB data set specifies options for the Multiple Systems Coupling (MSC) function of IMS. The section header must be specified as <SECTION=MSC>. The MSC section is valid in DB/DC and DCCTL environments.

The MSC section of the DFSDFxxx member defines attributes of the MSC function, such as MSC security options, dynamic definition of MSC resources, generic support for TCPIP links, and VTAM generic support for VTAM links.

Some of the parameters that can be specified in the MSC section of the DFSDFxxx member can also be specified in the DFSDCxxx member of the IMS PROCLIB data set. If you specify values in both the DFSDCxxx member and the DFSDFxxx member, the values that are specified in the DFSDCxxx member override the values that are specified in the DFSDFxxx member.

Syntax

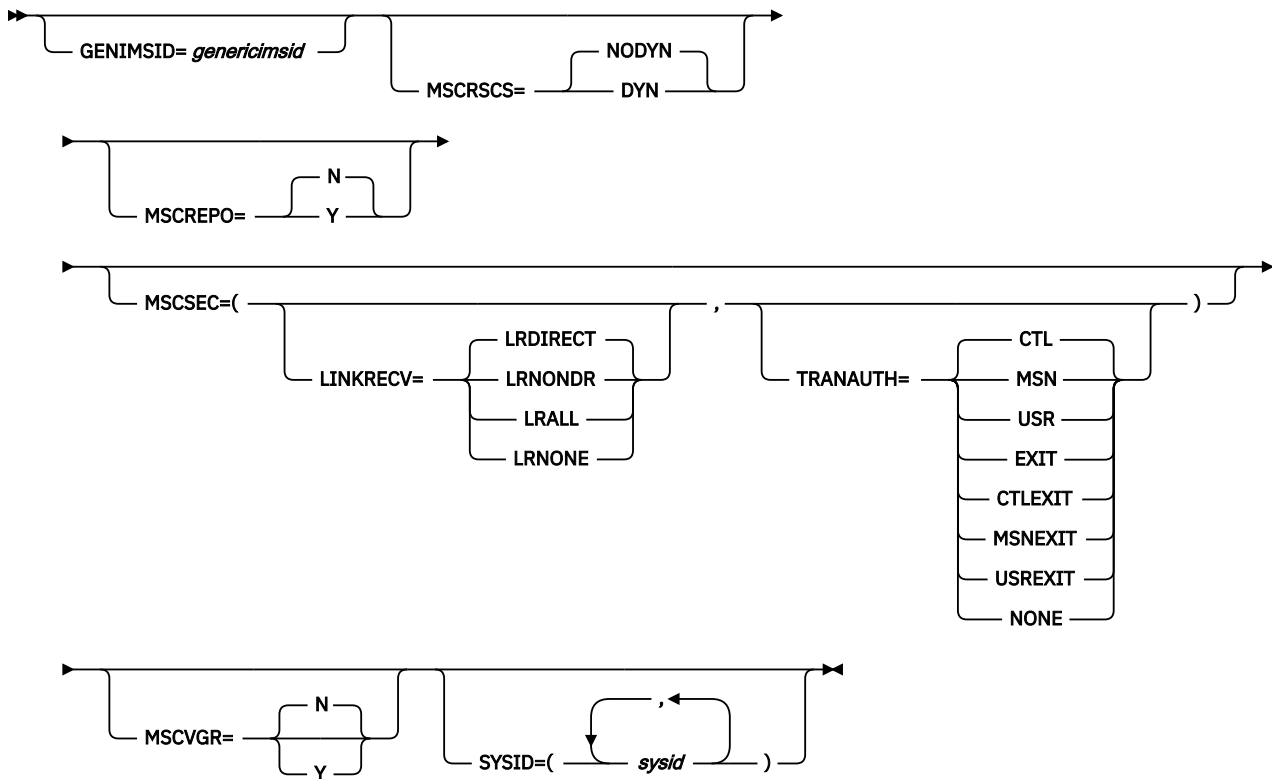

Parameters

The parameters of the MSC section of the DFSDFxxx member are described in the following list.

GENIMSID=

A 1- to 8-character alphanumeric shared IMS ID that identifies a TCP/IP generic resources group in an IMSplex.

The GENIMSID= parameter can be specified in either the DFSDCxxx PROCLIB member or in the MSC section of the DFSDFxxx PROCLIB member. Specifications in the DFSDCxxx PROCLIB member override specifications made in the DFSDFxxx PROCLIB member.

Each MSC-enabled IMS system in the IMSplex that participates in the TCP/IP generic resources group must specify the same shared IMS ID on the GENIMSID parameter.

The IMS Connect instance that supports TCP/IP generic resources group in the IMSplex must also specify the shared IMS ID on the GENIMSID parameter of the IMS Connect MSC configuration statement for each participating IMS system.

MSC-enabled IMS systems outside of the IMSplex connect to the IMSplex by specifying the shared IMS ID. The shared IMS ID is specified on the NAME parameter of the definition of the MSC physical link (MSPLINK) that defines a TCP/IP-type MSC physical link to the IMSplex. The IMS systems outside of the IMSplex do not need to define a MSC links to specific IMS systems in the IMSplex.

New connections to the TCP/IP generic resources group are accepted by the first IMS system to respond to the connection request when it is passed to the IMSplex by IMS Connect. After the connection has been accepted by a participating IMS system, the MSC physical link and all logical links assigned to it have affinity with that IMS system until the link is terminated.

The IMS ID must begin with an alphabetic character.

The value of GENIMSID cannot be the same as the IMS ID of any IMS system in the IMSplex or of any remote IMS system that connects to the IMSplex by using an MSC TCP/IP link.

MSCREPO=N|Y

Specifies whether MSC resources are stored in the IMSRSC repository. These MSC resources include physical links, logical links, logical link paths, and remote logical terminals. This attribute can be changed only on an IMS cold start.

This parameter is ignored if MSC dynamic resource definition is not enabled; that is, if MSCRSCS=DYN is not specified.

N

Disables MSC resources from being stored in the IMSRSC repository. N is the default value.

Y

Enables MSC resources to be stored in the IMSRSC repository, if the following items are defined:

- MODBLKS=DYN is defined in the COMMON_SERVICE_LAYER section of the DFSDFxxx member.
- MSCRSCS=DYN is defined in the MSC section of the DFSDFxxx member.
- AUTOIMPORT=AUTO or AUTOIMPORT=REPO is defined in the DYNAMIC_RESOURCES section of the DFSDFxxx member.
- AUTOEXPORT=AUTO or AUTOEXPORT=REPO is defined in the DYNAMIC_RESOURCES section of the DFSDFxxx member.

The MSC resources are automatically exported to the repository at IMS checkpoint and automatically imported into IMS from the repository at IMS cold start.

MSCRSCS=NODYN|DYN

Specifies whether MSC resources are defined dynamically by using online commands or statically by using stage-1 system definition macros. These resources include physical links, logical links, logical link paths, and remote logical terminals. This attribute can be changed only on an IMS cold start. If the value is changed for the next IMS warm or emergency restart, IMS restart terminates and abend U0168 is issued.

This parameter is ignored if MSC is not enabled in the IMS system.

NODYN

Disables the dynamic definition of MSC resources. MSCRSCS=NODYN is the default.

When MSCRSCS=NODYN is specified, resource definitions can be added, changed, or deleted only during system definition by coding the following stage-1 system definition macros:

- MSLINK
- MSNAME
- MSPLINK
- NAME

DYN

Enables dynamic definition for MSC resources. Resource definitions can be dynamically added, changed, or deleted by using online commands, including CREATE, DELETE, and UPDATE.

Changes that are made dynamically to MSC resources are not retained over a cold start of IMS unless the online definitions are exported to the IMSRSC repository or the changes were also coded in stage-1 system definition macros.

MSCSEC=()

Specifies the security options for direct and non-direct routed transactions received from an MSC link.

The MSCSEC= parameter can be specified in either the DFSDCxxx PROCLIB member or in the MSC section of the DFSDFxxx PROCLIB member. Specifications in the DFSDCxxx PROCLIB member override specifications made in the DFSDFxxx PROCLIB member.

LINKRECV=**LRDIRECT**

Specifies that Link Receive routing use RACF, the Transaction Authorization exit routine (DFSCTRNO), or both to check security for direct routed transactions. This is the default.

LRNONDR

Specifies that Link Receive routing use RACF, the Transaction Authorization exit routine (DFSTRNO), or both to check security for non-direct routed transactions. No security checking is performed for direct routed transactions.

LRALL

Specifies that Link Receive routing use RACF, the Transaction Authorization exit routine (DFSTRNO), or both to check security for direct and non-direct routed transactions.

LRNONE

Specifies that the IMS subsystem does not request any security checking for either type of transaction.

TRANAUTH=**CTL**

Specifies that RACF security is to authorize the use of the transaction based upon the user ID of the IMS control region.

MSN

Specifies that RACF security is to authorize the use of the transaction based upon the user ID of the MSNAME.

USR

Specifies that RACF security is to authorize the use of the transaction based upon the user ID of the inputting terminal.

EXIT

Specifies that authorization is performed by the Transaction Authorization exit routine (DFSTRNO).

CTLEXIT

Specifies that both RACF security and the Transaction Authorization exit routine (DFSTRNO) are used to authorize the IMS control region user ID to use the transaction.

MSNEXIT

Specifies that both RACF security and the Transaction Authorization exit routine (DFSTRNO) are used to authorize the MSNAME to use the transaction.

USREXIT

Specifies that both RACF security and the Transaction Authorization exit routine (DFSTRNO) are used to authorize the user ID of the inputting terminal to use the transaction.

NONE

Specifies that no security authorization checking is performed.

MSCVGR=N | Y

Specifies whether MSC links use the GRSNAME or the APPLID name in an IMS VGR environment.

The MSCVGR= parameter can be specified in either the DFSDCxxx PROCLIB member or in the MSC section of the DFSDFxxx PROCLIB member. Specifications in the DFSDCxxx PROCLIB member override specifications made in the DFSDFxxx PROCLIB member.

Y

IMS attempts to use the GRSNAME first to establish the session with the remote IMS. The remote IMS must use the value of the MSPLINK NAME=nodename for the IMSplex GRSNAME.

N

The APPLID name, not the GRSNAME, is used in an IMS VGR environment. This is true also if the remote IMS uses the IMSplex nodename. This is the default.

SYSID=()

Defines one or more system identifiers (SYSIDs) as local to this IMS system. A local SYSID is used to route response messages back to this IMS system.

The SYSID= parameter is required when MSC=Y is specified in the IMS execution parameters, unless one or more logical link paths are defined in either the IMSRSC repository or in an MSNAME stage-1

system definition macro. In either of these cases, the local SYSIDs for this IMS system are established from the logical link path definitions.

Valid values are 1 - 2036. Multiple SYSIDs must be separated by commas.

SYSIDs that are specified in the DFSDFxxx member do not override SYSIDs that are defined as remote, in either the IMSRSC repository or in an MSNAME macro, and are ignored. Message DFS3664I is issued for each SYSID that is ignored.

SYSIDs must be unique within an MSC network. However, within a single IMSplex or shared-queues group, the SYSIDs can be duplicated. For example, if you have multiple back-end IMS systems in an IMSplex with shared queues that are not connected to the MSC network but process MSC messages from the shared queue, specify the same SYSID in all of the back-end IMS systems.

To store SYSIDs, IMS creates a SYSID table. In an IMSplex with shared queues, the SYSID table is sent to the other IMS systems in the IMSplex. Each IMS system in the IMSplex builds a common SYSID table. The local SYSIDs of each IMS system in the IMSplex become local to all of the other IMS systems in the IMSplex.

To conserve online storage in shared-queues environments, always use the lowest possible SYSID values. In a shared-queues environment, the size of the table in storage is determined by the number of entries in the table. The number of entries in the table is determined by the highest specified SYSID value, up to 2036. Consequently, if the highest SYSID in a shared-queues group is relatively low, the SYSID table uses less storage.

Specifying the SYSID parameter does not require a predefined logical link.

Example of the MSC section

In the following example of the MSC section of the DFSDFxxx member, dynamic MSC is enabled, and several MSC SYSIDs are defined:

```
//*****/
/* IMS MSC Section */
//*****/
<SECTION=MSC> /* MSC definitions */
MSCRSCS=DYN /* DYNAMIC MSC ENABLED */
SYSID=(2,10,11,12,13,14,55) /* SYSTEM IDENTIFIERS */
//*****/
/* */
//*****/
```

OSAMxxx section of the DFSDFxxx member

The OSAMxxx section of the DFSDFxxx member specifies definitions used to dynamically add, update, or delete OSAM subpools. The section must begin with the header <SECTION=OSAMxxx>. The OSAMxxx section is valid in DB/DC, DBCTL, and batch environments.

By specifying OSAM subpool definitions in the DFSDFxxx member, you can dynamically change or delete subpools that have been specified with IOBF statements in the DFSVSMxx member.

The OSAMxxxsection in the DFSDFxxx member specifies the OSAM subpool definitions for reconfiguration. OSAMxxx is a dynamic section name. You can maintain multiple OSAMxxx sections in one DFSDFxxx member by specifying a unique suffix (xxx) for each section. Multiple sections are useful for storing commonly used definitions for future use. For example:

```
<SECTION=OSAMMON>
...
<SECTION=OSAMWED>
...
<SECTION=OSAMFRI>
...
...
```

You do not need to define multiple OSAMxxx sections in the DFSDFxxx member. You can define only one OSAMxxx section and modify the definition statements in that section before each invocation of the UPDATE POOL TYPE(DBAS) command. However, it might make sense to store commonly used definition statements that can be reused at future times.

This section is processed dynamically only by invocation of an UPDATE POOL TYPE(DBAS) command. With the UPDATE POOL TYPE(DBAS) command, you can specify which section name to use. For example:

```
UPDATE POOL TYPE(DBAS) SECTION(OSAMFRI)
```

The keywords in the OSAMxxx section can be specified multiple times to reference different subpool changes. The parameter values for each keyword are positional.

Syntax

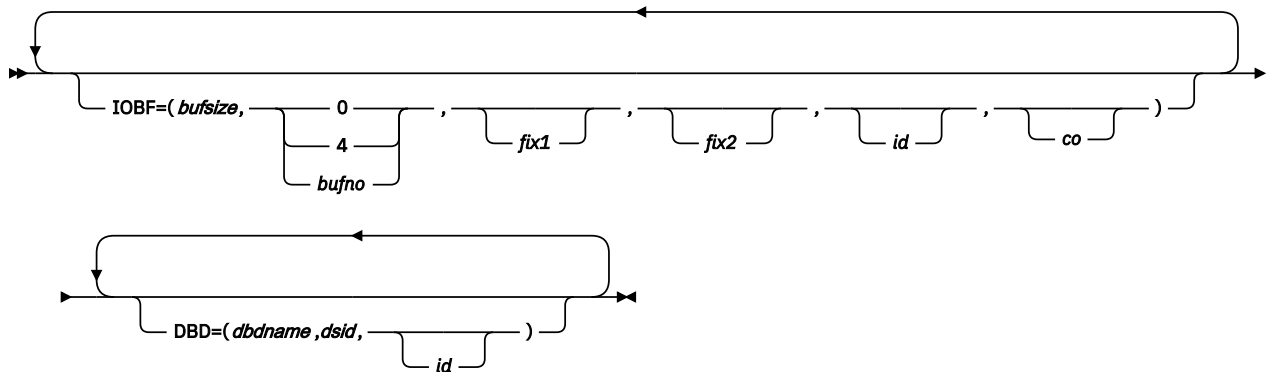

Parameters

IOBF=()

This keyword statement is for adding, updating, or deleting an OSAM subpool. The parameters supported on the IOBF statement are positional.

bufsize

This positional parameter specifies the size of the buffers in the subpool. The parameter value can be from 512 to 32768 bytes. The UPDATE POOL TYPE(DBAS) command rounds up the size value to 512, 1024, 2048, and thereafter to multiples of 2048. You can code specifications of 1024 and above as 1K, 2K, 4K, and thereafter round them up to multiples of 2 KB to a maximum of 32 KB. This parameter is required.

bufnum

This positional parameter specifies the number of buffers in the subpool. The parameter value can be 0 or 4 - 32767. If the value specified is less than 4 and not 0, the command overrides the value with 4. If the value specified is greater than 32767, the command overrides the value with 32767. A value of 0 indicates that the subpool is to be deleted. This parameter is required.

fix1

This positional parameter specifies the buffer long-term page-fixing option. Acceptable values are Y and N. If Y is specified, all buffers and buffer prefixes associated with this subpool are long-term page-fixed during configuration of the subpool. If N is specified, no buffers associated with this subpool are long-term page-fixed during configuration of the subpool. If the parameter is omitted, the command takes as default what was previously specified for the subpool. For the creation of new subpools, if the parameter is omitted, the default is N. This parameter is optional.

fix2

This positional parameter specifies the buffer prefix long-term page-fixing option. Acceptable values are Y and N. If Y is specified, all buffer prefixes associated with this subpool are long-term page-fixed during configuration of the subpool. If N is specified, the subpool header and all buffer prefixes associated with this subpool are not long-term page-fixed during configuration of the subpool. If the N parameter is omitted, the command takes as default what was previously

specified for the subpool. For the creation of new subpools, if the parameter is omitted, the default is N. This parameter is optional.

id

This positional parameter specifies the user-defined identifier that is assigned to a subpool. The ID is a 1- to 4-character alphanumeric field that is used with the DBD statement to assign a specific subpool to a given data set. If this parameter is not specified, the default subpool ID is null.

If two or more IOBF statements for the same subpool ID are specified for the same buffer size, the subsequent statements are rejected.

co

This positional parameter specifies the subpool caching option. This parameter is optional. You can specify the caching option in one of the following ways:

N

No data caching. Caching is not active for the subpool.

A

Cache all data. Write all data read from DASD and all changed data to the coupling facility.

C

Cache only changed data. Write all changed data written to DASD to the coupling facility.

If the parameter is not specified on the IOBF statement, the command takes as default what was previously specified for the subpool. For the creation of new subpools, if the parameter is omitted, the default is N.

The *co* option is valid only when an OSAM coupling facility structure has been allocated and a connection is active.

When increasing the number of buffers for an existing OSAM subpool, the values for *bufnum*, *fix1*, and *fix2* can be changed. The others are ignored if specified.

DBD=()

This keyword statement specifies that the indicated subpool is to be assigned to the data set having a matching ID parameter as defined on the IOBF= subpool definition statement. This statement is optional. The parameters supported on the DBD statement are positional.

dbdname

This positional parameter specifies the name of the database. The DBD name can be for a non-partitioned database, a HALDB partition, or a HALDB master. For a HALDB partition, specify the name of the partition as the *dbdname*. If the HALDB master name is specified, all the HALDB partitions associated with the HALDB are assigned to the same subpool. This parameter is required.

dsid

This positional parameter specifies the specific data set of a data set group within a database (identified by the *dbdname* parameter) that requests assignment of a specific pool. The number is an IMS internally assigned value 1 - 10. This parameter is required.

For data organizations such as primary index, unique secondary index, and HISAM without dependent segments, the primary data set of the data set group is assigned data set number 1. No secondary data set of the data set group exists for these data organizations.

For data organizations such as non-unique secondary index, and HISAM with dependent segments, the primary data set of the data set group is assigned data set number 1, and the secondary data set of the data set group is assigned data set number 2.

For hierarchic direct data organization, the data set group always consists of a single data set. The data set of the first data set group is assigned data set number 1, and data set numbers for subsequent data set groups are sequentially assigned numbers 2 - 10. The maximum number of data set groups for a database is 10.

Requirement: For High Availability Large Databases (HALDB), specify the data set number as a number or an alphabetic character. The valid data set numbers defined for HALDB partition data sets are 1 through 10 or A through J, L, and X. (When HALDB Online Reorganization is used, data

sets M through V and Y are automatically directed to the same shared resources pools for data sets A through J and X. The specification of M through V and Y are not valid.) The data set of the first data set group must be assigned the letter A (for both data sets A and M when HALDB Online Reorganization is used). The data set numbers for subsequent data set groups (B through J and N through V when HALDB Online Reorganization is used) must be sequentially assigned the other valid letters (B through J). Use the letter L to specify the indirect list data set. For PHIDAM databases, use the letter X (for both data sets X and Y when HALDB Online Reorganization is used) to specify the primary index data set.

id

This positional parameter specifies the user-defined identifier that is assigned to a specific subpool. The ID is a 1- to 4-character alphanumeric field that must be equal to the ID assigned to the specific subpool. This parameter is optional and defaults to a null value.

Subpools are assigned to data sets based upon buffer size. First, a subpool having buffers equal to or greater than the buffer size required for the data set is located. Then, if a specific subpool was requested, it is assigned, if its size is not less than the required size. In this case, the first subpool that meets the size criterion is assigned. The subpool might not have an ID assigned to it.

Example of the OSAMxxx section of the DFSDFxxx member

```

/*****
/* OSAM Section
/*****
<SECTION=OSAM001>
IOBF=(512,100,N,N)
IOBF=(1024,1000,N,N,OSM1,N)
IOBF=(2048,5000,Y,Y,OSM2,A)
IOBF=(4096,5000,N,Y,OSM3,N)
IOBF=(32K,32767,N,N,OSM9,N)

<SECTION=OSAM002>
IOBF=(512,100,N,N)
IOBF=(1024,1000,N,N,OSM1,N)
IOBF=(2048,5000,Y,Y,OSM2,A)
IOBF=(4096,5000,N,Y,OSM3,N)
IOBF=(32K,32767,N,N,OSM9,N)
DBD=(ABCDEFPC,01)
DBD=(XYZABC03,01,OSM1)
DBD=(XYZABC03,02,OSM1)
DBD=(JKLMNKA,A,OSM9)
DBD=(JKLMNKB,B,OSM9)
DBD=(JKLMNKA,J,OSM9)

<SECTION=OSAM003>
IOBF=(512,100)
IOBF=(1K,1000,,N,OSM1,N)
IOBF=(2K,7832,Y,,OSM2,C)
IOBF=(4K,32767,N,Y,OSM3)
IOBF=(32K,4,,OSM9,N)
DBD=(ABCDEFPC,01)
DBD=(XYZABC03,01,OSM1)
DBD=(ABCZZK5,01,OSM3)
DBD=(JKLMNKA,C,OSM9)
DBD=(JKLMNKB,F,OSM9)
DBD=(JKLMNKA,J,OSM9)
/*****
/*
/*****

```

Related concepts

[“OSAM subpool definition” on page 208](#)

OSAM subpools are defined using the IOBF and DBD statements. Specify the required subpools in the DFSVSAMP data set for batch environments, or in the DFSVSMxx member of the IMS PROCLIB data set for DB/DC environments. When using OSAM to access VSAM Linear data sets (LDS), the data is stored in the OSAM buffer pool. Supply enough OSAM buffer pool definitions (IOBF) to hold these data sets.

[“Specifying VSAM and OSAM subpools” on page 209](#)

Use control statements in the DFSVSAMP data set or the DFSVSMxx member of the IMS PROCLIB data set to specify VSAM and OSAM subpools.

REPOSITORY section of the DFSDFxxx member

The REPOSITORY section of the DFSDFxxx member specifies the repository types that are to be enabled at IMS. The valid type is: IMSRSC repository, which is used to store the stored resource definitions for DRD resources. The section must begin with the header <SECTION=REPOSITORY>. The REPOSITORY section is valid in DB/DC, DBCTL, and DCCTL environments.

Syntax

►► REPOSITORY — = — (— TYPE — = — IMSRSC —) ◄◄

Parameters

These parameters are applicable only if IMS is enabled with DRD. They are ignored if DRD is not enabled (MODBLKS=OLC or RMENV=N is specified in the Common Service Layer section of the DFSDFxxx member or in the DFSCGxxx member).

REPOSITORY=()

Defines the options for the repository that is used to store definitions for DRD resources.

TYPE=

Specifies the repository type.

The only valid value is IMSRSC. This value indicates the use of the IMS resource definition (IMSRSC) repository. With the IMSRSC repository, members of an IMSplex use a common repository to store the resources and descriptors for IMS databases, programs, routing codes, and transactions.

The repository can also be enabled dynamically by issuing the UPDATE IMS command.

Example of the REPOSITORY section of the DFSDFxxx member

```
/******  
/* Repository Section */  
/******  
<SECTION=REPOSITORY>  
REPOSITORY=(TYPE=IMSRSC)  
/******  
/* */  
/******
```

Related concepts

[“Overview of the IMSRSC repository” on page 37](#)

A repository is a generalized data storage facility that can be used to store any type of information. The IMS resource definition (IMSRSC) repository is a set of VSAM key sequenced data sets (KSDSs) used for storing information. The IMSRSC repository is a repository to store resource (and descriptor) definitions for IMS databases, transactions, programs, and routing codes. This repository is an alternative to the resource definition data set (RDDS) that is used with the dynamic resource definition (DRD) function.

Related tasks

[“Defining the IMSRSC repository” on page 40](#)

Before you can use the IMSRSC repository to store and retrieve resource and descriptor definitions, you must define it. In addition, IMS and the Resource Manager (RM) must have the repository enabled, the Repository Server (RS) must be started and active, and the repository must be started.

[Cold starting an IMS system that uses the IMSRSC repository \(Operations and Automation\)](#)

[“Importing MODBLKS resource and descriptor definitions by using the automatic import function” on page 85](#)

With dynamic resource definition (DRD) enabled, you can enable the automatic import function so that MODBLKS resource and descriptor definitions are imported to IMS during IMS cold start processing.

Related reference

[UPDATE IMS command \(Commands\)](#)

[“FRPCFG member of the IMS PROCLIB data set” on page 911](#)

Use the FRPCFG member of the IMS PROCLIB data set to define the Repository Server (RS) configuration parameters relating to performance, communications, and security. FRPCFG also identifies the names of the RS catalog repository data sets.

SHARED_QUEUES section of the DFSDFxxx member

The SHARED_QUEUES section of the DFSDFxxx member of the IMS PROCLIB data set specifies options for queue names, structure names, and group names. The section must begin with the header <SECTION=SHARED_QUEUES>. The SHARED_QUEUES section is valid in DB/DC and DCCTL environments.

Syntax

The syntax of the parameters that are specified for shared queues in the DFSDFxxx member are the same as the syntax and parameters specified for shared queues in the DFSSQxxx member of the IMS PROCLIB data set.

Parameters

All of the parameters that are valid in the DFSSQxxx member of the IMS PROCLIB data set are valid in the DFSDFxxx member of the IMS PROCLIB data set.

If you specify values in both the DFSSQxxx member and the shared-queues section of the DFSDFxxx member, the values specified in the DFSSQxxx member of the IMS PROCLIB data set override the values specified in the DFSDFxxx member. If you specify all your shared-queues values in the DFSDFxxx member, you can delete the DFSSQxxx member.

Example DFSDFxxx member for shared queues definitions

```
/******  
/* Shared Queues Section */  
/******  
<SECTION=SHARED_QUEUES>  
CQS=CQSCW1 /* CQS name */  
CQSSN=CQS1 /* CQS subsystem name */  
EMHQ=IMSEMHO01 /* EMHQ structure name */  
MSGQ=IMSMO01 /* MSGQ structure name */  
SQGROUP=GRUP1 /* XCF group name */  
/******  
/*  
/******
```

Related reference

[“DFSSQxxx member of the IMS PROCLIB data set” on page 854](#)

Use the DFSSQxxx member of the IMS PROCLIB data set to specify parameters related to the shared message queues and the CQS address space in DB/DC and DCCTL environments.

USER_EXITS section of the DFSDFxxx member

The USER_EXITS section of the DFSDFxxx member specifies the user exits to be called. The section must begin with the header <SECTION=USER_EXITS>. The USER_EXITS section is valid in DB/DC, DBCTL, and DCCTL environments.

Syntax

➡ EXITDEF=(TYPE= *exittype*,EXITS=(*exitname*)) →

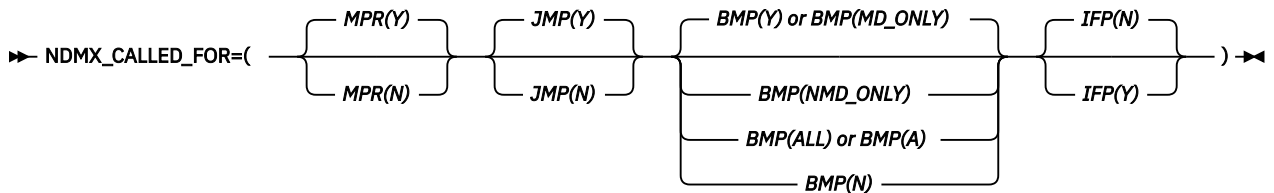

Parameters

EXITDEF()

Associates a user exit type with a list of one or more user exit routine modules to be called.

TYPE=*exittype*

Specifies the user exit type. User exits that can be specified include the following types:

- Build Security Environment User Exit (BSEX)
- IMS CQS Event user exit (ICQSEVNT)
- IMS CQS Structure Event user exit (ICQSSTEV)
- IMS Fast Monitor User Exit (FASTMON)
- IMS Monitor user exit (IMSMON)
- Initialization/Termination user exit (INITTERM)
- Log Edit user exit (LOGEDIT)
- Logger user exit (LOGWRT)

Note: The LOGWRT keyword might be specified for DLI and DBB batch regions. DCCTL batch regions do not support the USER_EXITS section.

- Non-Discardable Messages user exit (NDMX)
- OTMA Input/Output Edit user exit (OTMAIOED)
- OTMA Destination Resolution user exit (OTMAYPRX)
- OTMA Resume TPIPE Security user exit (OTMARTUX)
- Partner Product user exit (PPUE)
- Program Creation user exit (PGMCREAT)
- Resource Access Security user exit (RASE)
- Restart user exit (RESTART)
- Type-2 Automated Operator User Exit (AOIE)

EXITS=*exitnames*

Specifies a list of one or more exit routine names. The position of the exit routine in the list determines the order in which the exit routine is driven.

NDMX_CALLED_FOR()

Optional parameter applicable to the NDMX exit type. Specifies whether the NDMX exits specified on the EXITDEF=(TYPE=NDMX) statement are called for the region types that are listed on this parameter.

If NDMX_CALLED_FOR is not specified on the USER_EXITS section of the DFSDFxxx member, then by default MPR, JMP, and message-driven BMP regions are active, whereas IFP and non-message-driven BMP regions are inactive. You can change the default behavior by specifying region selection options. When you use multiple exits of the same type, your specified regions apply to all NDMX exit types. To implement your selection, update the DFSDF member, and then either restart the IMS or issue the command **REFRESH USEREXIT TYPE(NDMX)**. Note that the same DFSDF member must be maintained for all IMSs.



Attention: This parameter applies only to DB/DC and DCCTL environments.

Valid region selection options are as follows:

MPR (Y | N)

Specifies whether the NDMX exits specified on the EXITDEF=(TYPE=NDMX) statement are called for MPR regions. MPR(Y) is the default.

JMP (Y | N)

Specifies whether the NDMX exits specified on the EXITDEF=(TYPE=NDMX) statement are called for JMP regions. JMP(Y) is the default.

BMP (Y | MD_ONLY | NMD_ONLY | ALL | N)

Specifies whether the NDMX exits specified on the EXITDEF=(TYPE=NDMX) statement are called for message-driven or non-message-driven BMP regions. Several options are available:

- BMP(Y) is the default and enables **only** message-driven BMP regions. BMP(MD_ONLY) offers a more verbose way to specify the same behavior.
- BMP(NMD_ONLY) enables only non-message-driven BMP regions.
- BMP(ALL), which can also be specified with BMP(A), enables message-driven and non-message-driven BMP regions.
- BMP(N) specifies that the NDMX exits specified on the EXITDEF=(TYPE=NDMX) statement are not called for message-driven or non-message-driven regions.

To learn more, see [NDMX: Non-Discardable Messages user exit \(DFSNDMX0 and other NDMX exits\) \(Exit Routines\)](#).

IFP (N | Y)

Specifies whether the NDMX exits specified on the EXITDEF=(TYPE=NDMX) statement are called for IFP regions. IFP(N) is the default.

Example of the USER_EXITS section of the DFSDFxxx member (Single exit)

```
/* **** */
/* Restart exit section */
/* **** */
<SECTION=USER_EXITS>
  EXITDEF=(TYPE=RESTART, /* Restart User Exit */
            EXITS=(UEXIT1) /* Single exit */
  )
/* **** */
/* **** */
```

Example of the USER_EXITS section of the DFSDFxxx member (Multiple exits)

```
/* **** */
/* Restart exit section */
/* **** */
<SECTION=USER_EXITS>
  EXITDEF=(TYPE=RESTART, /* Restart User Exit */
            EXITS=(UEXIT1,UEXIT2,UEXIT3) /* Exit list */
  )
/* **** */
/* **** */
```

USER_EXITS section of the DFSDFxxx member (with NDMX_CALLED_FOR=(IFP(Y))

Enable calling the NDMX user exit for IFP regions along with the default options:

```
/* **** */
/* User exit section */
/* **** */
<SECTION=USER_EXITS>
  EXITDEF=(TYPE=NDMX,
            EXITS=(DFSNDMX0))
  NDMX_CALLED_FOR=(IFP(Y))
/* **** */
```



```

/*****/
/*
/*****/

```

Enable calling the NDMX user exit for IFP regions but not for MPRs:

```

/*****/
/* User exit section
/*****/
<SECTION=USER_EXITS>
  EXITDEF=(TYPE=NDMX,
            EXITS=(DFSNDMX0))
  NDMX_CALLED_FOR=(IFP(Y),MPR(N))
/*****/
/*
/*****/

```

USER_EXITS section of the DFSDFxxx member (various BMP options for NDMX_CALLED_FOR=)

BMP(Y) is the default and enables **only** message-driven BMP regions. BMP(MD_ONLY) is a more verbose way to enable the same behavior:

```

/*****/
/* User exit section
/*****/
<SECTION=USER_EXITS>
  EXITDEF=(TYPE=NDMX,
            EXITS=(DFSNDMX0))
  NDMX_CALLED_FOR=(BMP(MD_ONLY))
/*****/
/*
/*****/

```

Use BMP(NMD_ONLY) to enable calling the NDMX user exit for **only** non-message-driven BMP regions. Note that the text characters used to specify NDMX and NMD are similar, but are arranged in different orders (**NDMX** to specify EXITDEF type; **NMD** to specify non-message-driven BMP regions):

```

/*****/
/* User exit section
/*****/
<SECTION=USER_EXITS>
  EXITDEF=(TYPE=NDMX,
            EXITS=(DFSNDMX0))
  NDMX_CALLED_FOR=(BMP(NMD_ONLY))
/*****/
/*
/*****/

```

Use BMP(ALL) to enable calling the NDMX user exit for all BMP regions (which includes both message-driven and non-message-driven BMP types). This option can be specified with the slightly shorter BMP(A):

```

/*****/
/* User exit section
/*****/
<SECTION=USER_EXITS>
  EXITDEF=(TYPE=NDMX,
            EXITS=(DFSNDMX0))
  NDMX_CALLED_FOR=(BMP(ALL))
/*****/
/*
/*****/

```

Related concepts

[Refreshable exit routine types \(Exit Routines\)](#)

Related reference

[QUERY USEREXIT command \(Commands\)](#)

[REFRESH USEREXIT command \(Commands\)](#)

VSAMxxx section of the DFSDFxxx member

The VSAMxxx section of the DFSDFxxx member specifies definitions used to dynamically add, update, or delete VSAM subpools. The section must begin with the header <SECTION=VSAMxxx>. The VSAMxxx section is valid in DB/DC, DBCTL, and batch environments.

By specifying VSAM subpool definitions in the DFSDFxxx member, you can dynamically change or delete subpools that have been specified with VSRBF statements in the DFSVSMxx member.

The VSAMxxx section in the DFSDFxxx member specifies the VSAM subpool definitions for reconfiguration. VSAMxxx is a dynamic section name. You can maintain multiple VSAMxxx sections in one DFSDFxxx member by specifying a unique suffix (xxx) for each section. Multiple sections are useful for storing commonly used definitions for future use. For example:

```
<SECTION=VSAMJAN>
...
<SECTION=VSAMFEB>
...
<SECTION=VSAMMAR>
...
...
```

You do not need to define multiple VSAMxxx sections in the DFSDFxxx member. You can define only one VSAMxxx section and modify the definition statements in that section before each invocation of the UPDATE POOL TYPE(DBAS) command. However, it might make sense to store commonly used definition statements that can be reused at future times.

This section is processed dynamically only by invocation of an UPDATE POOL TYPE(DBAS) command. With the UPDATE POOL TYPE(DBAS), you can specify which section name to use. For example:

```
UPDATE POOL TYPE(DBAS) SECTION(VSAMJAN)
```

The keywords in the VSAMxxx section can be specified multiple times to reference different subpool changes. The following definition parameters for each keyword are positional and are listed in the correct order.

Syntax

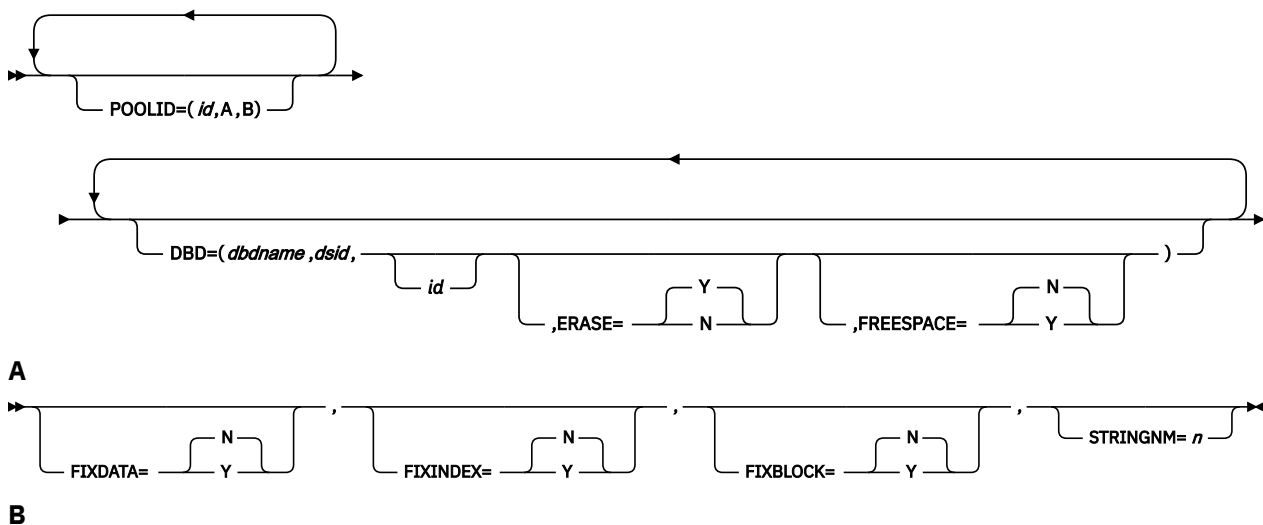

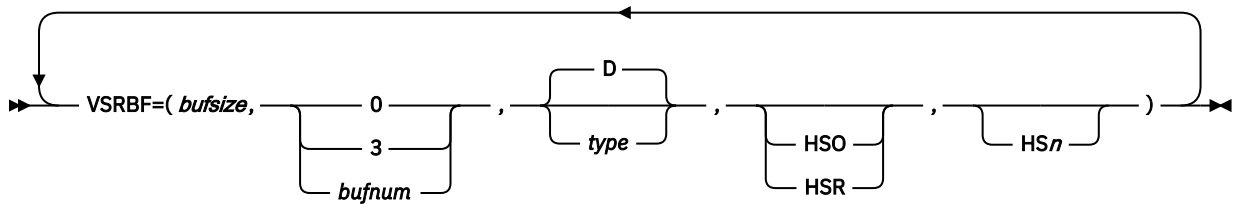

Parameters

POOLID=()

This keyword statement is for adding, updating, or deleting a subpool from a VSAM shared resource pool. Because the same shared resource pool can have multiple subpools in the same shared resource pool, you might have multiple POOLID statements for the same shared resource pool, but for different subpools. If multiple POOLID statements for the same shared resource pool are defined, only the occurrence of FIXDATA, FIXINDEX, FIXBLOCK, and STRINGNM parameter values specified on the first POOLID statement are recognized. Any subsequent occurrences of those parameter values belonging to the same shared resource pool are ignored. Those parameters apply to the VSAM shared resource pool as a whole.

A maximum of 255 VSAM shared resource pools is allowed.

id

This positional parameter specifies the user-defined identifier that is assigned to a VSAM shared resource pool. The ID is a 1- to 4-character alphanumeric field that is used with the DBD statement to direct a given data set to a specific shared pool. This parameter is required.

If two or more POOLID statements for the same ID are specified for the same buffer size and buffer type in the same shared pool, the subsequent statements are rejected.

FIXDATA=N | Y

This parameter specifies the data shared resource pool long-term-page-fixing option. If Y is specified, all buffers in the data shared resource pool are long-term page-fixed during configuration of the shared resource pool. If N is specified, no buffers in the data shared resource pool are long-term page-fixed. If the parameter is omitted, the command takes as default what was previously specified for the shared pool. For the creation of a new shared pool, if the parameter is omitted, the default is N. This parameter is optional.

FIXINDEX=N | Y

This parameter specifies the index shared resource pool long-term-page-fixing option. If Y is specified, all buffers in the index shared resource pool are long-term page-fixed during configuration of the shared resource pool. If N is specified, no buffers in the index shared resource pool are long-term page-fixed. If the parameter is omitted, the command takes as default what was previously specified for the shared pool. If this is for the creation of a new shared pool and the parameter is omitted, the default is N. This parameter is optional.

FIXBLOCK=N | Y

This parameter specifies the I/O related control blocks long-term-page-fixing option. If Y is specified, all I/O-related control blocks are long-term page-fixed during configuration of the shared resource pool. If N is specified, no I/O-related control blocks are long-term page-fixed. If the parameter is omitted, the command takes as default what was previously specified for the shared pool. For the creation of a new shared pool, if the parameter is omitted, the default is N. This parameter is optional.

STRINGNM=*n*

This parameter specifies the maximum number of VSAM I/O requests that can be concurrently active. The specified value must be a decimal number 1 - 255. The value specified is a number as close as possible to the maximum number of regions expected to be running concurrently, including the regions that are dynamically started. This parameter is optional.

Notes:

- When increasing the number of subpools for an existing VSAM shared resource pool, update the DFSDFxxx member with a POOLID, which identifies the VSAM shared resource pool that the subpool belongs to, followed by a VSRBF statement. For example:

```
POOLID=(id,VSRBF=(bufsize,bufnum,type,HS0,HSn))
```

or

```
POOLID=(id,VSRBF=(bufsize,bufnum,type,HSR,HSn))
```

- When adding a new VSAM shared resource pool, update the DFSDFxxx member with a POOLID statement, followed by one or more VSRBF subpool definition statements. For example:

```
POOLID=(id,Fixdata=Y,Fixindex=N,Fixblock=N,Stringnm=n,
VSRBF=(bufsize,bufnum,type,HSR,HSn))
```

- When decreasing the number of subpools for an existing VSAM shared resource pool, define the DFSDFxxx member with a POOLID, which identifies the VSAM shared resource pool the subpool belongs to, followed by a VSRBF statement. For example:

```
POOLID=(id,VSRBF=(bufsize,bufnum))
```

Set *bufnum* to 0 to indicate that the buffer is to be removed.

VSRBF=()

This parameter lists the VSAM subpool definitions for one subpool. The VSRBF parameter is required on the POOLID keyword statement. This behavior is different from how definitions are specified in the DFSVSMxx member. You can specify multiple VSRBF parameters. The following definition subparameters are positional and are listed in the correct order.

bufsize

This positional subparameter specifies the size of the buffers in the subpool. The parameter value can be in bytes, 512 - 32768. The UPDATE POOL TYPE(DBAS) command rounds up the size value to 512, 1024, 2048, 4096 and thereafter to multiples of 4096. You can code specifications of 1024 and above as 1K, 2K, 4K, and thereafter round them up to multiples of 4 KB to a maximum of 32 KB. This subparameter is required.

bufnum

This positional subparameter specifies the number of buffers in the subpool. The parameter value can be 0 or 3 - 32767. If the value specified is less than 3 and not 0, the UPDATE POOL TYPE(DBAS) command overrides the value with 3. If the value specified is greater than 32767, the command overrides the value with 255. A value of 0 indicates that the subpool is to be deleted. This subparameter is required.

type

This positional subparameter is a one-character field that specifies whether the subpool in the shared resource pool is an index subpool (I) or a data subpool (D). The default is D. This subparameter is optional.

HSO | HSR

This positional subparameter specifies the action IMS takes if Hiperspace (extended storage on z/OS) buffering for this subpool is not available. If this subparameter value is not specified when HSn is given, the command takes as default what was previously specified for the subpool. For the creation of a new subpool, if the parameter is omitted, then HSO is assumed when HSn is given. Otherwise, this subparameter is optional.

HSO

Indicates that Hiperspace buffering is optional and IMS can continue without Hiperspace buffering.

HSR

Indicates that Hiperspace buffering is required and IMS must terminate if Hiperspace buffering is not available.

HSn

This positional subparameter specifies a 1- to 8-character number *n* ranging from 3 to 16777,215 for the number of Hiperspace buffers to build for this subpool. This subparameter is optional.

HSO | HSR and HSn are valid only for subpool buffer sizes that are 4 KB or larger.

DBD=()

This keyword statement specifies that the indicated shared resource pool is to be assigned to the data set that has a matching ID parameter as defined on the POOLID= shared resource pool definition statement. This statement is optional. Except for the ERASE and FREESPACE parameters, the parameters supported on the DBD statement are positional.

dbdname

This positional parameter specifies the name of the database. The DBD name can be for a non-partitioned database, a HALDB partition, or a HALDB master. For a HALDB partition, specify the name of the partition as the *dbdname*. If the HALDB master name is specified, all the HALDB partitions associated with the HALDB are assigned to the same subpool. This parameter is required.

dsid

This positional parameter identifies the specific data set of a data set group within a database (identified by the *dbdname* parameter) that requests assignment of a specific shared resource pool. The number is an IMS internally assigned value 1 - 10. This parameter is required.

For data organizations such as primary index, unique secondary index, and HISAM without dependent segments, the primary data set of the data set group is assigned data set number 1. No secondary data set of the data set group exists for these data organizations.

For data organizations such as non-unique secondary index, and HISAM with dependent segments, the primary data set of the data set group is assigned data set number 1, and the secondary data set of the data set group is assigned data set number 2.

For hierarchic direct data organization, the data set group always consists of a single data set. The data set of the first data set group is assigned data set number 1, and data set numbers for subsequent data set groups are sequentially assigned numbers 2 through 10. The maximum number of data set groups for a database is 10.

Requirement: For High Availability Large Databases (HALDB), specify the data set number as a number or an alphabetic character. The valid data set numbers defined for HALDB partition data sets are 1 through 10 or A through J, L, and X. (When HALDB Online Reorganization is used, data sets M through V and Y are automatically directed to the same shared resources pools for data sets A through J and X. The specification of M through V and Y are not valid.) The data set of the first data set group must be assigned the letter A (for both data sets A and M when HALDB Online Reorganization is used). The data set numbers for subsequent data set groups (B through J and N through V when HALDB Online Reorganization is used) must be sequentially assigned the other valid letters (B through J). Use the letter L to specify the indirect list data set. For PHIDAM databases, use the letter X (for both data sets X and Y when HALDB Online Reorganization is used) to specify the primary index data set. For PSINDEX databases, you cannot code an alphanumeric character to designate the data set number. You must code a numeric value.

id

This positional parameter specifies the user-defined identifier that is assigned to a specific shared resource pool. The ID is a 1- to 4-character alphanumeric field that must be equal to the ID assigned to the specific shared resource pool. This parameter is optional and defaults to a null value.

ERASE=Y | N

Specifies whether deleted logical records are erased (Y) or only marked as deleted records (N). The default is Y. This parameter is optional. This parameter is not positional and must be specified after the positional parameters for the DBD statement.

FREESPACE=N | Y

Specifies whether the defined free space percentage in the KSDS is preserved (Y) or not (N). The default is N. This parameter is optional. This parameter is not positional and must be specified after the positional parameters for the DBD statement.

Example of the VSAMxxx section of the DFSDFxxx member

```
/*
/* * VSAM Section *
/*
<SECTION=VSAM001>
POOLID=(VSM1,VSRBF=(512,10))
POOLID=(VSM2,
VSRBF=(1024,1000,D),
VSRBF=(1024,1000,I))
POOLID=(VSM4,VSRBF=(4096,5000))
POOLID=(VSM9,VSRBF=(32K,32767,D))

<SECTION=VSAM002>
POOLID=(VSM1,VSRBF=(512,10))
POOLID=(VSM2,FIXDATA=N,FIXINDEX=Y,FIXBLOCK=N,STRINGNM=255,
VSRBF=(1024,500,D),
VSRBF=(1024,99,I),
VSRBF=(8192,6000,D))
POOLID=(VSM4,FIXDATA=Y,FIXINDEX=Y,STRINGNM=100,VSRBF=(8192,25,I))
POOLID=(VSM9,FIXINDEX=Y,FIXBLOCK=N,STRINGNM=200,VSRBF=(32K,32767,D))
DBD=(DEVABZ02,01,VSM1)
DBD=(ABCIDJ03,01,VSM2)
DBD=(DEVBTZ02,01,VSM4)
DBD=(DEVBTZ02,02,VSM4)
DBD=(ABHONKB,A,VSM9)
DBD=(ABHONKJ,B,VSM9)

<SECTION=VSAM003>
POOLID=(VSM1,VSRBF=(512,10))
POOLID=(VSM2,FIXDATA=N,FIXINDEX=Y,FIXBLOCK=N,STRINGNM=255,
VSRBF=(1024,500,D),
VSRBF=(1024,99,I),
VSRBF=(1024,99,I),
VSRBF=(8192,6000,D))
POOLID=(VSM4,FIXDATA=Y,FIXINDEX=Y,STRINGNM=100,VSRBF=(8192,25,I))
POOLID=(VSM9,FIXINDEX=Y,FIXBLOCK=N,VSRBF=(32K,32767,D))
DBD=(DEVABZ02,01,VSM1)
DBD=(ABCIDJ03,01,VSM2)
DBD=(DEVBTZ02,02,VSM4)
DBD=(ABHONKB,A,VSM9,ERASE=Y,FREESPACE=N)
DBD=(ABHONKJ,B,VSM9)
/*
/* *
/*

```

Related concepts

[“VSAM subpool definition” on page 207](#)

VSAM subpools are defined using the VSRBF control statement, one of the control statements in the DFSVSMxx member of the IMS PROCLIB data set.

[Adjusting OSAM and VSAM database buffers \(Database Administration\)](#)

[“Specifying VSAM and OSAM subpools” on page 209](#)

Use control statements in the DFSVSAMP data set or the DFSVSMxx member of the IMS PROCLIB data set to specify VSAM and OSAM subpools.

DFSDRFnn member of the IMS PROCLIB data set

Use the DFSDRFnn member of the IMS PROCLIB data set to specify that portions of the control region be placed in disabled reference (DREF) storage during initialization.

With this member, VTAM terminal blocks (VTCBs) in DREF storage are never paged out to auxiliary storage; they remain in real or expanded storage. DFSDRFnn requires that the system have sufficient expanded storage available for the VTCBs. If you choose the DREF option for VTCBs during installation, but do not have expanded storage, the VTCBs DREF storage are page fixed.

Environments

This member of the IMS PROCLIB data set is not applicable in the DBCTL environment.

Syntax

➤ BLOCKS=VTCB ➤

Usage

If the VTCBs have been paged out of real storage when a checkpoint occurs, DFSDRFnn can improve the time to bring them back into real storage.

The *nn* suffix of DFSDRFnn is taken from the IMS procedure FIX=nn initialization parameter, the same one used for the page fixing member, DFSFIXnn (see [“DFSFIXnn member of the IMS PROCLIB data set”](#) on page 830).

If you specify either DFSDRFnn or DFSFIXnn, define the one you do not choose to use as a null member. For example, if you specify FIX=55, define both members (DFSDRF55 and DFSFIX55), and make the member you do not need a null member containing a blank control statement. Without both defined, IMS issues error message DFS0579, indicating a member could not be found. If DFSFIXnn is defined as a null member, message DFS0757 is issued, reminding you that no fixing requests were made.

If BLOCK=VTCB is requested in DFSFIXnn and in DFSDRFnn, the page-fix request in DFSFIXnn is ignored.

Parameters

The control information is contained in 80-character records. Continuation or sequencing must not be entered. The format is as follows:

BLOCKS=

VTCB

Specifies that VTCBs are loaded into DREF storage, but are never to page to auxiliary storage.

DFSDSCMx member of the IMS PROCLIB data set

When the Extended Terminal Option (ETO) is enabled, IMS generates ETO descriptors during stage 1 system definition and stores them in the DFSDSCMx member of the IMS.PROCLIB data set.

IMS generates both default descriptors and descriptors that are based on any static definitions in the IMS stage-1 system definition macros. The types of descriptors that IMS can generate include logon descriptors, MFS device descriptors, MSC descriptors, and user descriptors.

Recommendation: If you code your own descriptors, do not store them in the DFSDSCMx member. The contents of the DFSDSCMx member are deleted and regenerated each time a stage 1 system definition is performed. To preserve descriptors that you code across a stage-1 system definition, store them in the DFSDSCTy member of the IMS.PROCLIB data set.

The *x* on DFSDSCMx is the IMS nucleus suffix. The suffix must match a suffix that your installation specifies on the SUFFIX= parameter of the IMSGEN system definition macro.

To use IMS ETO, at least one user descriptor and one logon descriptor must exist. If at least one of each of these descriptors does not exist or cannot be found when you enable IMS ETO, IMS abends with U0015 issuing message DFS3652.

The following rules apply to creating ETO descriptors:

- Separate one keyword or parameter set from another with one or more blanks.
- Do not include embedded blanks within a keyword and its parameters.
- Separate a keyword from its parameters with an equal sign (=).

- Do not abbreviate keywords.

You can continue a keyword and its parameter set to the next statement if no intervening blanks appear at the end of the first statement or at the beginning of the parameters of the next statement. A continued statement still has the same descriptor type and name in columns 1-10; the continued specification begins in column 12. If you specify keywords, they must be accompanied by parameters. Keywords followed by blanks or commas are invalid.

The format and parameters of the ETO descriptors are described in the following topics:

Related concepts

[“ETO descriptors” on page 214](#)

When you are enabling ETO support in your installation, you can optionally request that IMS produce ETO descriptors during system definition. You do this with the ETOFEAT keyword in the IMSCTRL macro.

Related reference

[“DFSDSCTy member of the IMS PROCLIB data set” on page 827](#)

Use the DFSDSCTy member of the IMS PROCLIB data set to specify override descriptors for the Extended Terminal Option (ETO), including logon descriptors, MFS device descriptors, MSC descriptors, and user descriptors.

[“IMSGEN macro” on page 437](#)

Use the IMSGEN macro to specify the assembler and binder data sets and options, and the system definition output options and features.

[Coding ETO descriptors \(Communications and Connections\)](#)

Common format of ETO descriptor statements

Each descriptor statement must be 80 characters in length.

All statements are translated to uppercase. The basic format of each of the descriptor types is shown in the following table.

Table 69. Descriptor type formats

Column number	Contains	Considerations
01	The descriptor type indicator: L (logon) M (MSC) U (user) D (MFS device)	If an asterisk (*) is in column 01, the record is considered a comment record and is ignored.
03-10	The descriptor name	<ul style="list-style-type: none"> • All descriptor names must be 1-8 alphanumeric characters. • The first character for logon and user descriptors must be alphabetic (A-Z, #, \$, or @). • Duplicate descriptor names are allowed if they are grouped, because more parameters might be required than can exist in an 80-byte record. • For MSC descriptors, this column contains the link name.
12-72	Parameters for each descriptor	<ul style="list-style-type: none"> • Parameters vary by type. • They are delineated by blanks. • They are typically in the same format as the equivalent parameters specified in the stage 1 input deck.

Table 69. Descriptor type formats (continued)

Column number	Contains	Considerations
73-80	Can contain sequence numbers	IMS ignores these columns.

Logon descriptor format and parameters

Because logon descriptors are built from equivalent TYPE and TERMINAL macros, most definitions of logon descriptor parameters match the parameters found on those macro statements.

Because you do not need to define the maximum number of ETO-ISC sessions, the SESSION keyword is not supported on the ETO descriptor. You can continue to add sessions while storage and CPC capacity exist. The UNIT keyword is valid for non-SNA 3270 terminals only.

Logon descriptor syntax

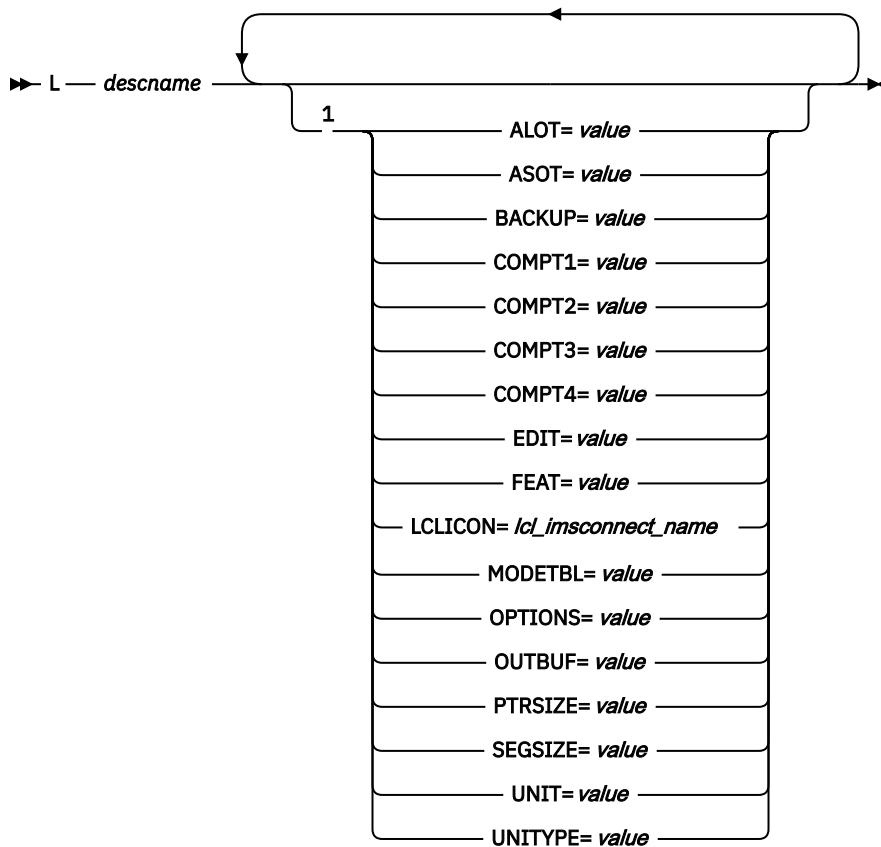

Notes:

¹ Each parameter can be specified only once. Parameters can be specified in any order.

Keyword parameters

Except for the descriptor type, L, and the descriptor name, all keyword parameters are specified in columns 12 through 72.

L

Specified in column 1, indicates that the descriptor type is logon.

descname

Specified in columns 03-10, the name of the descriptor. Descriptor names can be an IMS default descriptor name, the name of a TERMINAL macro, or a unique name you create.

Default names include:

- DFS3270
- DFS327P
- DFSFIN
- DFSLU61
- DFSNTO
- DFSSLU1
- DFSSLU2
- DFSSLUP
- DFSTCP

ALOT=

Specifies the auto logoff time in minutes. Valid values are 0 and from 10 to 1440. If the ALOT value is not specified, the value from the JCL member is used except for FINANCE, SLU P, and ISC. If ALOT is not specified on the logon descriptor or overridden by the logon exit (DFSLGNX0) for FINANCE, SLU P, and ISC, a value of 1440 is used (the value from the JCL member is ignored).

- ALOT= 0

The terminal is logged-off immediately when no signon is in effect. This specification is normally used in terminal sessions when the user is signed-on automatically during the logon process. During autologon, signon data can be provided in one of the following ways:

- Signon data supplied by the IMS /OPNDST command
- Signon data supplied by logon userdata (BIND)
- Signon data supplied by logon exit (DFSLGNX0)

There are two modes of operation for using ALOT=0, either of which can be set using the DFSINTX0 User Initialization Exit parameter list.

In default mode, when signon errors are encountered, the session is automatically signed off and then logged off; no message is sent. If you do not supply the DFSINTX0 exit, or you supply the exit and indicate default mode for ALOT=0, then signon data must be supplied during the logon process. All the following error conditions result in automatic logoff:

1. A non-signon, or errors detected during signon or input processing, result in immediate logoff.
2. /SIGNOFF results in immediate logoff.
3. /SIGNON signs off the current user and signs on a new user. However, errors encountered during the signon process, such as detection of an incorrect or expired password, result in immediate logoff.

Restriction: Default mode should not be used for interactive terminal sessions that require a response to the DFS3649 message; these sessions do not wait for input signon and log off immediately.

In alternate mode, when signon errors are encountered, the session is automatically signed off, a message is sent, and the session is logged off. Signon data can be supplied but is not required. All the following error conditions result in automatic logoff:

1. A non-signon error detected during input processing results in immediate logoff.
2. No signon data has been provided by the logon userdata (BIND) or the Logon Exit (DFSLGNX0).
3. A /SIGNOFF, or errors resulting from a /SIGNON, cause message DFS3649(A) (Signon Required) to be sent, and a fixed ten-minute timer set to wait for a new signon. If no signon occurs during that interval, then the session is logged off.

- ALOT=(10-1439)

The session is terminated after the specified number of minutes have elapsed without a signed-on user.

- ALOT=1440

The session is never automatically terminated.

ASOT=

Specifies the auto signoff time, in minutes. Valid values are 0 and from 10 to 1440. You can override this value during signon with the user descriptor. If ASOT is not specified on either the user descriptor, the logon descriptor, or overridden by either the logon (DFSLGNX0) or signon (DFSSGNX0) exits, the value from the JCL member is used except for FINANCE, SLU P, and ISC. If ASOT is not specified on either the user or logon descriptor for FINANCE, SLU P, and ISC, a value of 1440 is used (the value from the JCL member is ignored).

- ASOT=0

The user is signed off immediately when no output is available to be sent. ASOT=0 is normally specified when no IMS input or output is available, or after the last available output message completes.

Restriction: Do not specify ASOT=0 for interactive terminals, for example 3270s or SLU2.

- ASOT=(10-1439)

The user is signed off after the specified number of minutes have elapsed without terminal activity, irrespective of message status.

- ASOT=1440

The user is never automatically signed off.

BACKUP=

Specifies the control of session switching (VTAM) after takeover. Use only when HSB=YES on the IMSCTRL macro.

This keyword is the same as the BACKUP= keyword in the TYPE macro. See [“TYPE macro” on page 514](#) for more information about keyword values.

COMPTn=

Where *n* is 1-4, specifies the first through fourth components of this logon descriptor. This keyword is only valid for the following device types: 3270, FINANCE, SLU 1, SLU P, and LU6.1 (ISC). For UNITYPE=FINANCE, these four keywords are the same as the four operands on the TERMINAL macro's COMPT keyword. The parameters for this keyword are positional. See [“TERMINAL macro” on page 471](#) for more information about this keyword for other device types.

COMPT=PTR1 for UNITYPE=3270, UNIT=3275 should be specified as COMPT2=PTR1.

EDIT=

Specifies the name of a user-supplied physical terminal output and input edit routine for the terminals in this communication description set.

This keyword is the same as the EDIT= keyword in the TYPE macro. See [“TYPE macro” on page 514](#) for more information about keyword values.

FEAT=

The parameters for this keyword are not positional.

See the description of the FEAT= keyword in [“TERMINAL macro” on page 471](#) and [“TYPE macro” on page 514](#) for more information about this keyword.

LCLICON=

Specifies the local IMS Connect instance that IMS communicates with for the ISC TCP/IP communication. This keyword is supported only when UNITYPE=ISCTCPIP is specified.

For ISC TCP/IP, this keyword identifies the local IMS Connect (IMSCON) member within an IMSplex that this ISCTCPIP terminal connects to via SCI, to establish a connection to the IMSCON within this IMSplex. A *lcl_imsconnect_name* is a 1 to 8 alphanumeric character name. The first character is alphabetic.

MODETBL=

Specifies the name of the VTAM logon mode table entry (logon mode name) that contains the SNA bind parameters to be used when a session is initiated by the MTO or through the /OPNDST command.

This function allows a system definition specification for referencing an entry other than the default entry in the user's VTAM logon mode table. Normally, the terminal operator specifies this mode table entry name when logging on to a terminal; this is not possible, however, from the IMS master terminal because IMS initiates the session.

With this function, if MODETBL= is not specified at system definition, no functional or operational change affects the user.

If MODETBL= is specified at system definition, the specified entry name is used. The MODETBL can be overridden by:

- The LOGON APPLID entry by the remote terminal operator
- VARY ACT, LOGON= command by the network terminal operator
- /OPNDST, /RST, or /CHANGE command by the MTO

The MODETBL= parameter is required for the IMS master terminal if the VTAM default mode table is not configured specifically for the device to be used as the IMS master terminal.

With MODETBL=, you do not need to specify the mode table entry when logging on to terminals that always require specification of the same mode table entry name.

OPTIONS=

Specifies certain communication options associated with this terminal. Parameters for this keyword are not positional.

The ARNR | NRNR option specifies whether (ARNR) or not (NRNR) IMS should enable Rapid Network Reconnect (RNR) support for ACF/VTAM persistent sessions as defined in the ACF/VTAM APPL statement.

Unless otherwise noted, the communications options described in the OPTIONS= keyword of the TYPE and TERMINAL macros are supported for logon descriptors. See [“TERMINAL macro” on page 471](#) and [“TYPE macro” on page 514](#) for more information about this keyword.

The following options are not supported for logon descriptors:

- NOSHARE | SHARE
- ACK | OPTACK
- NORESP | FORCRESP | TRANRESP
- SIGNON | NOSIGNON

NORESP | FORCRESP | TRANRESP can be specified on the user descriptor.

The COPY | NOCOPY option is supported for logon descriptors for dynamic SLU 2 terminals, but not for dynamic non-SNA VTAM 3270s.

OUTBUF=

Specifies the size of the IMS output buffer to be used for workstations.

This keyword is the same as the OUTBUF= keyword on the TERMINAL macro. See [“TERMINAL macro” on page 471](#) for more information about this keyword.

PTRSIZE=

Specifies the number of print positions of the 3284 or 3286 printer. The default is 120.

If PTRSIZE=IGNORE is specified with FEAT=IGNORE in its DEV statement, MFS always uses the device output format (DOF) when editing output for this device. The existing parameters and control block values, including default parameters, are unchanged.

SEGSIZE=

Specifies segment size. Acceptable values are from 256 bytes to 32000 bytes. The default is 256. For information about calculating segment size, see the description of the SEGSIZE= keyword in [“TERMINAL macro” on page 471](#).

UNIT=

Specifies the terminal for the previously defined line group.

This keyword is the same as the UNIT= keyword on the TERMINAL macro. See [“TERMINAL macro” on page 471](#) for more information about this keyword.

UNITYPE=

Specifies the UNITYPE of the terminal. If not specified, a default UNITYPE of SLUTYPE2 is used.

3601 is not a valid UNITYPE.

The following values are valid for the UNITYPE keyword:

- 3270
- FINANCE
- ISCTCPIP
- LUTYPE6
- NTO
- SLUTYPE1
- SLUTYPE2
- SLUTYPEP

Examples of logon descriptors

An example of a logon descriptor is:

```
Column      Column
1           12
L MKT01LU2 UNITYPE=SLUTYPE2 ALOT=30
```

You can use multiple records to create a single descriptor name (for example, if the number of parameters causes the descriptor to exceed one 80-byte record).

The following is an example of a logon descriptor with multiple records:

```
L MKT01LU2 UNITYPE=SLUTYPE2
L MKT01LU2 ALOT=30
```

Related concepts

[“Logon descriptors” on page 215](#)

Logon descriptors provide IMS with information about the physical characteristics of the terminals that establish logon sessions.

Related tasks

[Creating logon descriptors \(Communications and Connections\)](#)

MFS device descriptor format and parameters

MFS device descriptors are used by the MFS Device Characteristics Table (MFSDCT) utility.

The MFSDCT utility updates screen information, for example 3270 screen sizes and feature information, in the DCT and generates new MFS default formats without system definition.

You use MFS device descriptors to define characteristics of terminals added dynamically that have different characteristics from statically defined terminals.

Related reading: See *IMS Version 15.4 Database Utilities* for more information about how to use the MFSDCT utility.

Syntax of the MFS device descriptor

►► D — *descname* — FEAT= *value* — SIZE= *value* — TYPE= *value* ►►

Keyword parameters of the MFS descriptor

The following list describes each element of an MFS device descriptor statement.

Except for the descriptor type, D, and the descriptor name, all keyword parameters are specified in columns 12 through 72.

D

Indicates that the descriptor type is MFS (device).

descname

The name of the descriptor.

FEAT=*value*

For a description of this parameter, see [“TERMINAL macro” on page 471](#).

SIZE=*value*

For a description of this parameter, see [“TERMINAL macro” on page 471](#).

TYPE=*value*

For a description of this parameter, see [“TERMINAL macro” on page 471](#).

Example

An example of an MFS device descriptor is:

```
Column      Column
1           12
D IMSTYP22  TYPE=3270-A04 SIZE=(43,80) FEAT=IGNORE
```

Related concepts

[“MFS device descriptors” on page 216](#)

Use MFS device descriptors to define characteristics of terminals added dynamically that have different characteristics from statically defined terminals.

Related tasks

[Creating MFS device descriptors \(Communications and Connections\)](#)

Related reference

[“TERMINAL macro” on page 471](#)

Use the TERMINAL macro statement to define physical and logical characteristics of VTAM nodes and non-VTAM communication terminals.

MSC descriptor format and parameters

MSC descriptors relate remote NAME macros to MSC links defined during system definition.

When you specify with ETOFEAT that descriptors are to be created during system definition, an MSC descriptor is created for each MSNAME macro statement.

Syntax of the MSC descriptor

►► M — *linkname* — *ltermname* ►►

Keyword parameters of the MSC descriptor

The descriptions of the variables in the MSC descriptor are:

M

Indicates the descriptor type is MSC (device).

linkname

The name of the link path from an MSNAME statement.

ltermname

Specifies the name of a logical terminal associated with a physical terminal that is defined in a remote IMS system.

Examples

An example of an MSC descriptor is:

```
Column      Column
1           12
M REMSYS01  REM01AAA  REM01BBB  REM01CCC  REM01DDD  REM01EEE  REM01FFF
M REMSYS02  REM01GGG  REM01HHH  REM01III
```

Related concepts

[“MSC descriptors” on page 217](#)

MSC descriptors relate remote NAME macros to MSC links defined during system definition.

Related tasks

[Creating MSC descriptors \(Communications and Connections\)](#)

User descriptor syntax and parameters

User descriptors provide information relating to user options and user structure names.

Unless noted, the definition of a given user descriptor parameter is the same as that found for the equivalent NAME ([“NAME macro” on page 465](#)) and SUBPOOL macro statement ([“SUBPOOL macro” on page 470](#)). Also, unless noted, the general rules for creating descriptors apply to the following user descriptors.

User descriptor syntax

► U — *username* — ASOT= *value* — AUTLDESC= *value* — AUTLGN= *value* — AUTLID= *value* →

 ► AUTLMOD= *value* — LTERM= *value* — OPTIONS= *value* — RCVYCONV= *value* →

 ► RCVYFP= *value* — SRMDEF= *value* ◄

Keyword parameters of the user descriptor

The values in the user descriptor statement are described in the following list.

Except for the descriptor type, U, and the user name, all keyword parameters are specified in columns 12 through 72.

U

Indicates the descriptor type is user.

username

The name of the descriptor, which can be a unique user ID you create, a node user name assigned to a TERMINAL or SUBPOOL macro, or the IMS default descriptor name, DFSUSER.

ASOT=*a*

a is 0 or a value from 10 to 1440. The default comes first from the logon descriptor parameter ASOT. If ASOT is not specified on either the user or logon descriptor, the value from the JCL member is used

except for FINANCE, SLU P, and ISC. If ASOT is not specified on either the user or logon descriptor for FINANCE, SLU P, and ISC, or overridden by the logon (DFSLGNX0) or (DFSSGNX0) exits, then a value of 1440 is used, the value from the JCL member is ignored.

AUTLDESC=d

d is a one- to eight-byte alphanumeric logon descriptor name, the first character of which is alphabetic (A-Z, \$, #, @). AUTLDESC=d defines the characteristics of the terminal to be autologged on. This parameter is ignored for LU 6.1 devices.

AUTLGN=b

b is a one- to eight-byte alphanumeric LU name for auto logon, the first character of which is alphabetic (A-Z, \$, #, @). Autologon allows IMS to logon and signon your terminal automatically. If you specify the autologon option for a user, the queuing of data to any of the user queues causes IMS to establish a session.

Related reading: For more information, see [Autologon \(Communications and Connections\)](#).

AUTLID=g

g is a one- to eight-byte alphanumeric ISC other system half session qualifier, of which the first character is alphabetic (A-Z, \$, #, @). If the other system is IMS, then this is the name of an ISC user in that system. The AUTLGN parameter must be used with the AUTLID parameter when requesting autologon for an ISC parallel session.

AUTLMOD=e

e is a one- to eight-byte alphanumeric mode table for the autologon terminal.

LTERM=(f,h,i,j)

f, h, i, and *j* are all positional parameters. *f* is a one- to eight-byte alphanumeric LTERM name. *h* is either ULC or UC; the default is ULC. *i* is the COMPT parameter, and *j* is the ICOMPT parameter. COMPT and ICOMPT are the same as defined by keyword parameters on the NAME macro. If *f* is the only parameter supplied, the parentheses can be omitted.

A maximum of eight queues can be specified for each user descriptor.

If no LTERM keyword is specified, the user descriptor control block structure is built with one queue. The name used as the descriptor name is the default.

The queue names specified on the LTERM parameter keyword for the user descriptors must be unique. That is, two user descriptors cannot be created with the same queue name. If duplicate LTERM names are specified, message DFS3669 is issued.

If the LTERM keyword is specified on the user descriptor, the queue name must also be specified. The DFSUSER descriptor must also follow this convention (for example, with queue name DFSUSER).

The queue names (and Remote LTERM names) must follow the same naming conventions as the user names because they can, in some circumstances, take on the same name as the user name. The user name has strict naming conventions because it must follow RACF naming conventions. Therefore, these names must be alphanumeric (A-Z, 0-9, \$, #, @), but the first character in the name must not be 0-9.

OPTIONS=j,k

j is a response mode of FORCRESP, TRANRESP, or NORESP. The default response mode is dependent upon the device type. If the response mode is not explicitly set in the user descriptor, the default cannot be set until signon, when the device type is known. The default setting for each device type, during signon, is indicated in the following table.

<i>Table 70. Default response mode values</i>	
Device type	Default response mode
3270	NORESP
FINANCE	NORESP
LU 6	TRANRESP

Table 70. Default response mode values (continued)

Device type	Default response mode
NTO	TRANRESP
SLU 1	TRANRESPX
SLU 2	NORESP
SLU P	NORESP

k is an MSGDEL option of SYSINFO, NONIOPCB, or NOTERM. The default is SYSINFO.

If OPTIONS=NOTERM is specified for a user descriptor, when that user descriptor is used for a sign on of a FINANCE, SLU P, or ISC terminal, SYSINFO issued instead of NOTERM.

The OPTION parameters are not positional. Refer to the MSGDEL and OPTIONS parameters of the TERMINAL macro for descriptions.

RCVYCONV=

Specifies whether the status of a conversation can be recovered (Y) or not (N). RCVYCONV applies to conversation status, not to output messages. Even if the conversation status is not recovered, conversation output continues to be recoverable and is delivered asynchronously.

The following table shows the default values for RCVYCONV as they relate to the values specified on the SRMDEF keyword.

Table 71. RCVYCONV values related to SRMDEF values

	RCVYCONV=YES	RCVYCONV=NO
SRMDEF=GLOBAL	Valid (default)	Valid
SRMDEF=LOCAL	Valid (default)	Valid
SRMDEF=NONE	Invalid	Valid (default)

If RCVYCONV is specified incorrectly, message DFS1920I is issued and IMS uses the appropriate default from the preceding table.

RCVYFP=

Specifies whether the status of Fast Path can be recovered (YES) or not (NO). RCVYFP applies to Fast Path status and output.

The following table shows the default values for RCVYFP as they relate to the values specified on the SRMDEF keyword.

Table 72. RCVYFP values related to SRMDEF values

	RCVYFP=YES	RCVYFP=NO
SRMDEF=GLOBAL	Valid (default)	Valid
SRMDEF=LOCAL	Valid (default)	Valid
SRMDEF=NONE	Invalid	Valid (default)

Restriction: If SRMDEF=LOCAL, STSN recoverability (RCVYSTSN) and fast path recoverability (RCVYFP) must be the same. They must both specify YES or both specify NO.

If RCVYFP is specified incorrectly, message DFS1920I is issued and IMS uses the appropriate default from the preceding table.

RCVYSTSN=

Specifies whether the status of STSN terminals (SLUP, FINANCE, and ISC) can be recovered (Y) or not (N).

The following table shows the default values for RCVYSTSN as they relate to the values specified on the SRMDEF keyword.

Table 73. RCVYSTSN values related to SRMDEF values

	RCVYFP=YES	RCVYFP=NO
SRMDEF=GLOBAL	Valid (default)	Valid
SRMDEF=LOCAL	Valid (default)	Valid
SRMDEF=NONE	Invalid	Valid (default)

Restrictions: If SRMDEF=LOCAL, STSN recoverability (RCVYSTSN) and fast path recoverability (RCVYFP) must be the same. They must both specify YES or both specify NO. If SRMDEF=GLOBAL, Fast Path is always nonrecoverable, so if there is a failure during the execution of a fast path transaction, the STSN session must be restarted cold.

If RCVYSTSN is specified incorrectly, message DFS1920I is issued and IMS uses the appropriate default from the preceding table.

SRMDEF=

Specifies the status recovery mode for user and node resources. Valid values are GLOBAL, LOCAL, and NONE.

Related reading: In order to understand what the GLOBAL, LOCAL, and NONE values mean, you have to first understand how IMS classifies resource status. For a discussion of these concepts, see *IMS Version 15.4 System Administration*.

The following list describes the valid values for SRMDEF.

GLOBAL

The significant status of a resource is saved globally in the coupling facility resource structure every time the significant status changes, along with all other recoverable status for that resource. The resource status is restored at the next logon or signon and is available from any IMS system in the IMSplex. Resource status is copied to the local system when that resource becomes active, but is deleted from the local system when it becomes inactive. Status is not recovered in local IMS log records.

Requirement: Using a status recovery mode of GLOBAL requires a Resource Manager and a resource structure in the coupling facility.

LOCAL

The significant status is saved in local control blocks and log records, along with all other recoverable resource status. The resource status is restored at the next logon or signon if the user or node returns to the same local IMS system. This status is not available on any other IMS system in the IMSplex.

LOCAL mode enforces an affinity for the user or node to the IMS system where the local status exists. This is referred to as RM affinity. IMS prevents the user or node from accessing any other IMS while local status exists. If the IMS system that has local status fails, the node and user are allowed access to another IMS system. In this case, the node or user does not recover any status and when the failed IMS restarts, the local status that existed is deleted.

Using a status recovery mode of LOCAL does not require a Resource Manager. If RM is not used to manage node or user resources, then no RM affinity is enforced.

NONE

The significant status is not saved by RM or in local log records. When the user signs on or the node logs on, the corresponding significant status does not exist.

Examples

An example of a user descriptor specification is:

Column	Column
1	12
U SMITH	ASOT=20 LTERM=(SECLT1) AUTLGN=SEC01LU2

Related concepts

[“User descriptors” on page 217](#)

User descriptors are another form of descriptor created during system definition for ETO. Node user descriptors are essentially migration aids, allowing message queues and options associated with a particular terminal to remain unchanged during migration.

Related tasks

[Creating user descriptors \(Communications and Connections\)](#)

Related reference

[“TERMINAL macro” on page 471](#)

Use the TERMINAL macro statement to define physical and logical characteristics of VTAM nodes and non-VTAM communication terminals.

DFSDSCTy member of the IMS PROCLIB data set

Use the DFSDSCTy member of the IMS PROCLIB data set to specify override descriptors for the Extended Terminal Option (ETO), including logon descriptors, MFS device descriptors, MSC descriptors, and user descriptors.

The descriptors that you can specify in the DFSDSCTy member, as well as the syntax and parameters of those descriptors, are exactly the same as the descriptors that you can specify in the DFSDSCMx member. However, if a descriptor is specified on both members, the specifications coded in the DFSDSCTy member for the descriptor override the specifications coded in the DFSDSCMx member.

The ETO descriptors supported by the DFSDSCTy and DFSDSCMx members include:

- Logon descriptors
- MFS device descriptors
- MSC descriptors
- User descriptors

To use IMS ETO Support, at least one user descriptor and one logon descriptor must exist in either the DFSDSCMx or the DFSDSCTy member. If one or both of the logon and user descriptors do not exist when you enable IMS ETO Support, IMS abends with U0015 issuing message DFS3652.

By default, the suffix y on DFSDSCTy is 0. You can define a different value as the suffix by specifying the value on the DSCT= parameter in the IMS or DCC startup procedures.

The syntax and parameters of the ETO descriptors are documented under [“DFSDSCMx member of the IMS PROCLIB data set” on page 815](#)

Related concepts

[“ETO descriptors” on page 214](#)

When you are enabling ETO support in your installation, you can optionally request that IMS produce ETO descriptors during system definition. You do this with the ETOFEAT keyword in the IMSCTRL macro.

Related tasks

[Creating logon descriptors \(Communications and Connections\)](#)

Related reference

[“DFSDSCMx member of the IMS PROCLIB data set” on page 815](#)

When the Extended Terminal Option (ETO) is enabled, IMS generates ETO descriptors during stage 1 system definition and stores them in the DFSDSCMx member of the IMS.PROCLIB data set.

[“Parameter descriptions for IMS procedures” on page 520](#)

All of the parameters that can be specified in startup procedures in the IMS environment are documented in the following subtopics.

DFSFDRxx member of the IMS PROCLIB data set

Use the DFSFDRxx member of IMS PROCLIB data set to specify the Fast Database Recovery (FDBR) options used by the FDR.

Multiple DFSFDRxx members can be present in the IMS PROCLIB data set. The FDRMBR= parameter in the FDR, IMS, or DBC procedure identifies the member currently in effect.

Environments

This member is applicable to the FDBR region and the FDBR-capable IMS or DBC regions.

Syntax

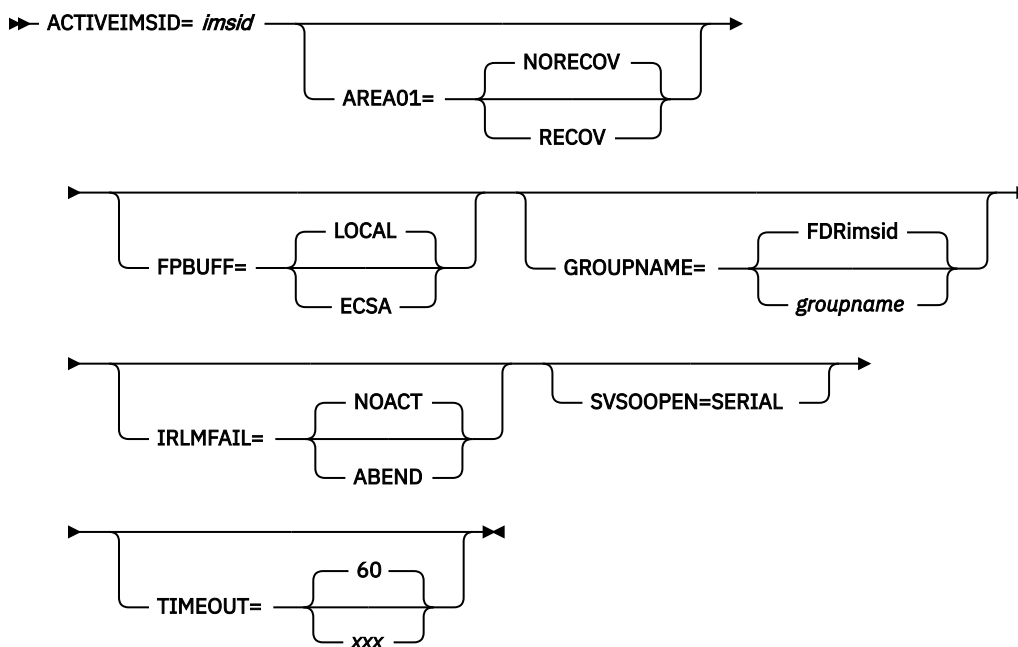

Usage

The record format is

Position Contents

1-71

Option parameters separated by commas

72-80

Ignored

The first parameter in a record can have leading blanks. The last parameter in a record is denoted by a comma, followed by one or more blanks. The last parameter in the last record is followed by one or more blanks.

Parameters can occur in any order in the control statement. Multiple control statements can be provided.

Both the 64-bit pools and non-resident 31-bit pools in IMS active systems and their associated FDBR and XRF alternate systems should have identical contents. Whatever parameters and values you specify on the active IMS system should be the same on the alternate IMS system. For example, the parameters

specified in the DFSVSMxx, DFSDfxxx, and DFSPBxxx members of the IMS PROCLIB data set must be the same; the sizes of the PSB and DMB pools must be the same.

Parameters

ACTIVEIMSID=

Specifies the IMS ID for the subsystem that the active FDBR region tracks. For IMS and DBC procedures (FDBR capable regions), ACTIVEIMSID must match the IMS ID defined in the procedure. This parameter is required.

AREA01=

Specifies whether Fast DB Recovery applies to DEDB areas defined as SHARELVL= 0|1. This parameter applies to FDR procedures. IMS and DBC procedures ignore it if it is specified.

RECOV

Specifies that Fast DB Recovery applies to SHARELVL= 0|1 areas.

NORECOV

Specifies that SHARELVL= 0|1 areas are not recovered by FDBR. Succeeding IMS emergency restarts recover the areas after FDBR completion.

The default is NORECOV.

FPBUFF=

Specifies where the control blocks for DEDB processing are allocated. This keyword is optional. If you do not specify this parameter, control blocks for DEDB processing are allocated in the FDBR control region private storage.

LOCAL

DEDB control blocks and buffer pools for shared VSO are allocated in the FDBR control region private storage. This is the default for IMS 15.4.

ECSA

DEDB control blocks and buffer pools for shared VSO are allocated in ECSA storage.

GROUPNAME=

Specifies the z/OS cross-system coupling facility group name for the active IMS system and the tracking FDBR region. This parameter is optional. If you do not specify GROUPNAME=, a default name is created by using the ACTIVEIMSID= parameter and the prefix FDR. For example, if the active IMSID is IMS1, the default XCF group name is FDRIMS1.

IRLMFAIL

Specifies the action IMS should take if IRLM fails.

ABEND

IMS to issue abend U3305 if IRLM fails.

NOACT

IMS takes no action if IRLM fails and continues normal processing. NOACT is the default.

SVSOOPEN=SERIAL

Specifies that all areas requiring redo processing in an FDBR system are serially processed. This option is ignored for emergency restart and XRF takeover processing. Use this option to reduce the number of structures that are allocated by FDBR for redo processing.

TIMEOUT=

Specifies the number of seconds that FDBR waits before determining a timeout status for the tracked IMS. Valid values are from 3-999.

The default is 60.

If a value less than 3 is specified, the value 3 is used. If a value greater than 999 is specified, 999 is used.

This parameter is applicable to IMS and DBC procedures.

The value you specify with this parameter applies only to IMS timeout status from XCF. For log surveillance, FDBR uses a five-second timeout value, and a three-second delay interval before calling DBRC to check whether an OLDS switch has occurred.

Related tasks

[“Enabling an IMS subsystem for FDBR” on page 135](#)

To reduce the amount of time the sharing subsystems must wait, you can use Fast Database Recovery (FDBR) regions to enable DB/DC and DBCTL subsystems.

DFSFIXnn member of the IMS PROCLIB data set

Use the DFSFIXnn member of the IMS PROCLIB data set to specify that portions of the control region (for example, certain control blocks, buffer pools, loaded modules, and part of the IMS nucleus) be fixed in address space during initialization.

Place control information in the IMS PROCLIB data set (typically named IMS.PROCLIB), as part of member DFSFIXnn, where nn is a two-character field supplied in the PARM field of the EXEC statement for the control region. See [“Environments that support IMS.SDFSRESL procedures” on page 518](#).

If you are running XRF, you can define an additional DFSFIXnn member. This member is identified by the DEFERFIX=xx parameter in the DFSHSBxx member of the IMS PROCLIB data set and can contain only non-Fast Path page-fix options for the control region. In the active system, both page-fix lists are processed. In the alternate system, the page fix list specified by the DEFERFIX=xx parameter is not processed until takeover. This allows you to control how much page fixing takes place in the alternate system while it is in tracking mode.

Environments

This member can be used in the IMS DB/DC and DBCTL environments.

Syntax

Recommendation: Specify BLOCKS=FP if your system uses Fast Path. If you do not specify BLOCKS=, either CPU performance can be seriously affected or system abends can be received, or both.

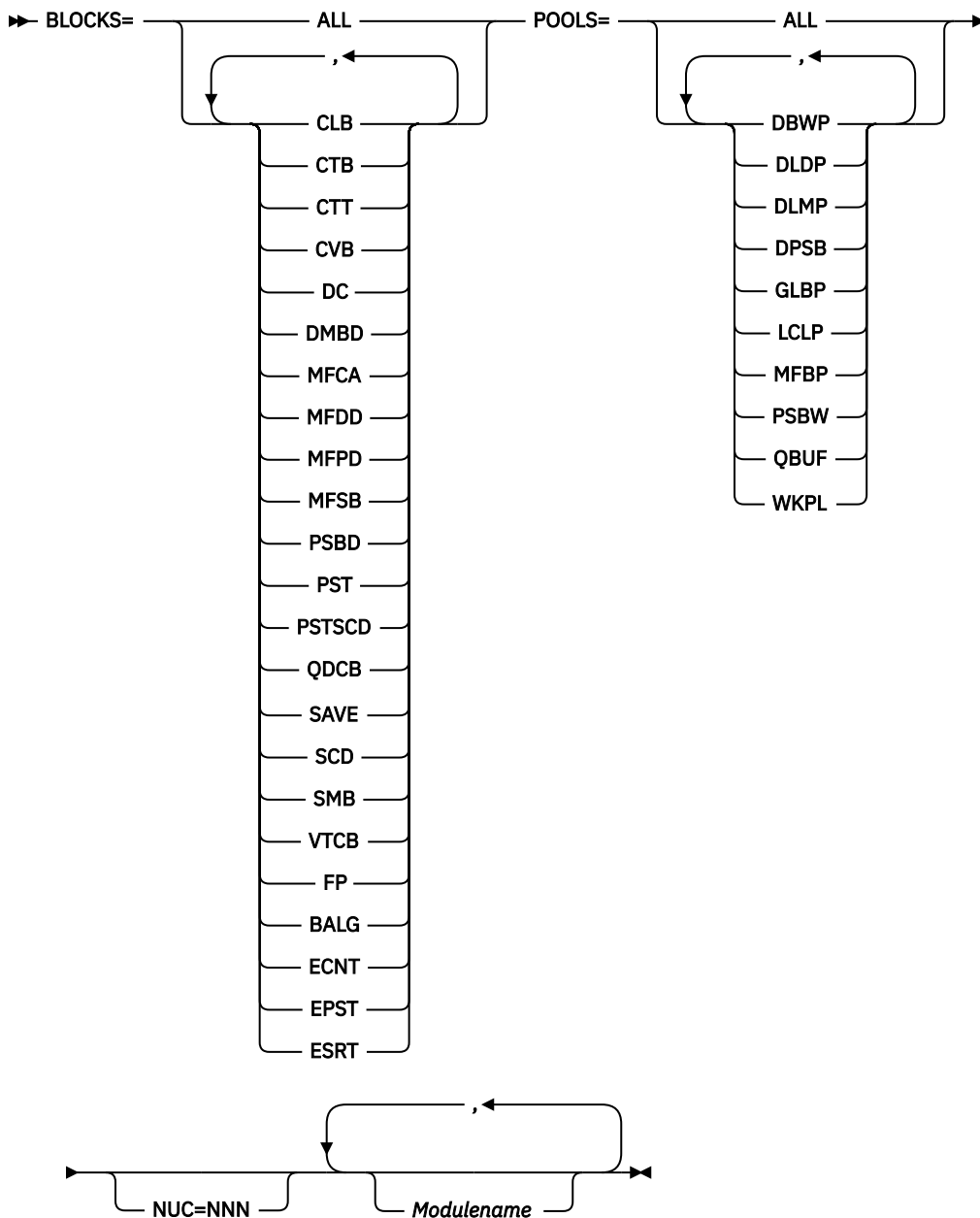

Usage

The control information is contained in 80-character records. Continuation or sequencing must not be entered. In addition:

- Either commas or blanks can be used to separate parameters, except BLOCKS, POOLS, and NUC, which are followed by an equal (=) sign.
- The *nnn* subparameter of NUC= can be any one, two, or three-digit number from 1 to 100.
- Following the BLOCKS or POOLS parameters, either ALL or any subset of the list of blocks or pools, respectively, can be coded.
- Parameters (NUC, BLOCKS, POOLS, Modulename) can be entered in any order and can be repeated as desired. If NUC is repeated, the percentage specified on the last NUC= is used. If BLOCKS or POOLS is repeated, a block or pool is fixed if it is specified in any of the BLOCKS= or POOLS= specifications.
- The subparameters of blocks and pools can be specified in any order.
- Invalid parameters are ignored, an error message is issued, and scanning continues.

- An invalid format or an invalid word (one not beginning with an alphabetic character) causes all scanning to stop and an error message to be issued. No fixing is done.
- All 80 characters in each record are available for control information.
- The modulename must be specified as the full eight-character name of a loaded module.

Parameters

BLOCKS=

ALL

All blocks listed this list.

CLB¹

Non-VTAM communication line block

CTB¹

Non-VTAM communication terminal block

CTT¹

Communication translate table

CVB

Communication verb block

DC¹

Non-VTAM CLB and non-VTAM CTB

DMBD or DMBDIR

Database directories

MFCA¹

Message format buffer pool control area

MFDD¹

MFS dynamic directory, (including hash table, prime area, and up to 10 additional areas)

MFPD¹

MFS PDS directory indexes, (single area including one index per concatenation)

MFSB¹

MFS staging buffers

PSBD or PSBDIR

Program directories

PST

Dependent region PSTs

PSTSCD

Blocks PST and SCD

QDCB¹

Message queue DCBs

SAVE

Save area prefixes

SCD

System Contents Directory

SMB¹

Scheduler message blocks

VTCB¹

VTAM terminal control blocks

FP

BALG, ECNT, EPST, and ESRT

BALG¹

Load balancing group control blocks

ECNT¹

Extension to the Communication Node Tables (CNTs)

EPST

Extension to the Partition Specification Tables (PSTs)

ESRT¹

Message retrieve buffers

Note: ¹This keyword is not applicable in the DBCTL environment.

The following Fast Path control blocks, which are always page fixed, are not included in the preceding list:

BHDR

Main storage database headers

DMHR

Database buffer headers

LBUF

Synchronization point log buffer

DEDB

Control blocks for data entry databases: data management control blocks (DMCBs) and data management area control blocks (DMACs)

ESCD

Extension to the System Content Directory (SCD)

OTHR

Output thread control blocks

POOLS

This is the dynamic area acquired by IMS during initialization and used for various buffer pools.

ALL

All pools listed in this list.

DBWP

DMB work pool

DLDP

DMB pool

DLMP

With the DL/I address space option, that portion of the PSB pool in the z/OS common area.

DPSB

With the DL/I address space option, the portion of the PSB pool in DL/I local storage. Specification is ignored if the DL/I address space option is not in effect.

GLBP

Following storage pools are included: WKPL, DLMP, PSBW, DLDP, and DBWP. If the DL/I address space is used, DLDP and DBWP are not included.

LCLP¹

Following storage pools are included: QBUF and MFBP. If the DL/I address space is used, DPSB, DLDP, and DBWP are also included.

MFBP¹

Message format buffer pool

PSBW

PSB work pool

QBUF¹

Message queue buffer pool

WKPL

General working pool

Note: ¹This keyword is not applicable in the DBCTL environment.

The parameters GLBP and LCLP can represent large amounts of storage. The terms GLBP and LCLP should not be interpreted as global and local storage, because the location of these pools can vary, based on whether the local storage option or the DL/I address space option is in effect. You should avoid using GLBP and LCLP; specify the pools to be fixed by name.

NUC=*nnn*

Is the percentage (specified by *nnn*) of the IMS load module (DFSVNUCx) to be page fixed.

If NUC=*nnn* is specified, a percentage of the nucleus, starting at location 0, is fixed regardless of what is placed there. IMS system definition places all the DC control blocks at the low end of the nucleus.

Modulename

The name of a loaded module. The specification of a module name does not cause that module to be fixed unless it has already been loaded into storage. (Module DFSVNUC0 cannot be fixed in this manner. See the NUC= keyword.)

If the DL/I address space option is being used, an attempt is made to fix a module in both the control and DL/I address spaces. If the module is loaded in only one of these address spaces, a message indicating that the module cannot be fixed is issued, in addition to the successful fix message.

Examples

The example in “[Example of DFSFIXnn](#)” on page 834 causes:

- Module DFSDLR00 to be fixed
- 76% of the IMS nucleus to be fixed
- The control program nucleus blocks DC, SMB, PST, and SCD to be fixed
- The message format buffer pool to be fixed

The member specified in the EXEC PARM field is read and processed during the IMS initialization procedure.

A list of the fixed pages is maintained during the execution of IMS. When IMS terminates, this list is used to free the fixed pages before returning to z/OS.

Example of DFSFIXnn

```
DFSDLR00 NUC=76 BLOCKS=DC,SMB,PSTSCD POOLS=MFBP
```

DFSHSBxx member of the IMS PROCLIB data set

Use the DFSHSBxx member of the IMS PROCLIB data set to specify the XRF options used by the active and alternate subsystems in an XRF complex.

Multiple DFSHSBxx members can be present in IMS PROCLIB data set. The HSBMBR= parameter in the IMS procedure identifies the member currently in effect.

An XRF complex has two DFSHSBxx members in effect at any time, one for the active system, and one for the alternate subsystem. The two members need not be identical, but the USERVAR and RSENAME parameters must be the same, and the surveillance options should be the same. If MNPS is used for terminal switching, then the USERVAR parameter is not applicable. Instead, the MNPS parameters must be the same in the two members.

Environments

This member is not applicable in the DBCTL environment.

Syntax

The XRF option parameters can occur in any order in the control statement. Multiple control statements can be provided.

RSENAME= is required for all XRF complexes. Either USERVAR= or MNPS= is required if you use VTAM for XRF terminal switching.

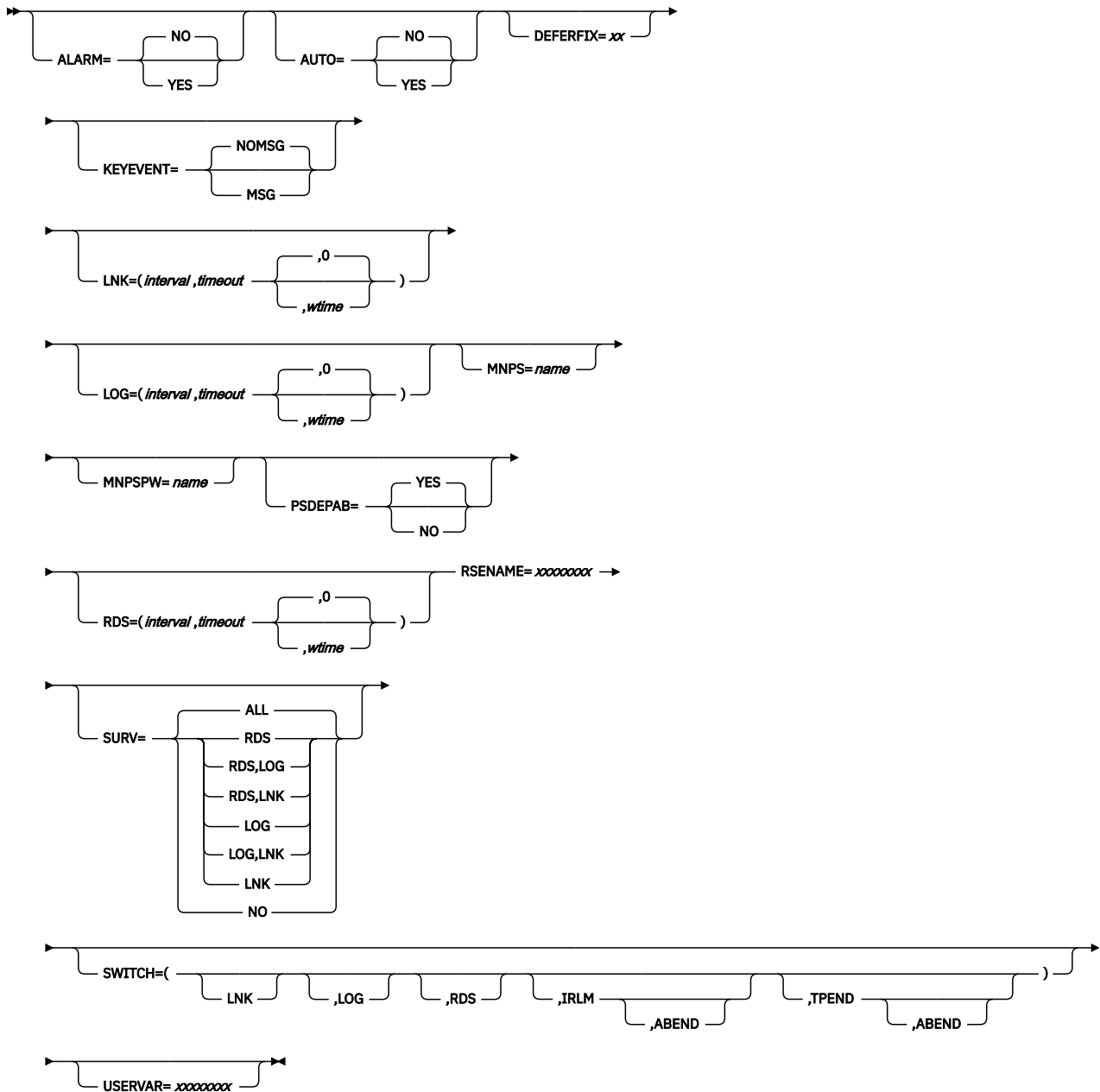

Restrictions

Usage

The parameters in this member can have different meanings, depending on whether the subsystem is the active or the alternate subsystem.

The record format is:

Position Contents

1-71

Option parameters separated by commas

72-80

Ignored

The first parameter in a record can have leading blanks. The last parameter in a record is denoted by a comma, followed by one or more blanks. The last parameter in the last record is followed by one or more blanks.

Parameters

ALARM=

Specifies whether (YES) or not (NO) the service processor alarm on the alternate subsystem sounds at takeover request. The default is NO.

AUTO=

Specifies whether (YES) or not (NO) a takeover is to proceed automatically. The default is NO.

DEFERFIX=xx

Identifies the DFSFIXxx member of IMS.PROCLIB containing the non-Fast Path page fixing options for the control region, which are processed during the restart of an active subsystem, and when the alternate subsystem becomes the active during takeover.

KEYEVENT=

Controls whether your IMS operator receives all XRF- related messages.

- MSG indicates that noncritical-event messages and critical-event messages are sent.
- NOMSG indicates that only critical-event messages are sent.

The default is NOMSG.

LNK=(interval,timeout,wtime)

Specifies the timing values for the ISC link surveillance. The default is (3,9).

interval

In the active subsystem, specifies how often (1 to 99 seconds) IMS sends signals across the ISC link.

In the alternate subsystem, specifies how often (1 to 99 seconds) IMS checks for those signals.

See [Table 74 on page 837](#) for additional information about coding the interval value.

timeout

In the alternate subsystem, specifies how long (1 to 999 seconds) IMS waits for a signal before considering a takeover.

See [Table 75 on page 837](#) for additional information about coding the timeout value.

wtime

Alternate IMS issues a warning message if the surveillance of active IMS is suspended longer than this value in seconds. Valid values are 0 - 4294967295. The default is 0. This warning message is issued repeatedly with wtime interval while long delay condition continues. A /STO SURV ALL, LNK, LOG or RDS command will disable the warning message function. If this wtime is omitted or 0 is specified, no warning message is issued in XRF alternate IMS.

LOG=(interval,timeout,wtime)

Specifies the timing values for the log surveillance. It also determines the frequency with which the alternate subsystem accesses the log, after it has caught up. The default is (1,3).

interval

In the alternate subsystem, specifies how often (1 to 99 seconds) IMS checks to see if a new log record is received from the active subsystem.

This parameter also determines the frequency with which the alternate subsystem attempts to read a new log record, after the alternate has caught up with the active. If you do not specify LOG surveillance or do not specify the interval value, the alternate subsystem waits one second between reads to the log (only if the alternate has caught up with the active).

See [Table 74 on page 837](#) for additional information about coding the interval value.

Table 74. Initializing the INTERVAL value

Subsystem	Requirement	Exception action
Alternate	Alternate interval value must be greater than or equal to active interval value.	DFS3812 issued. Alternate interval value forced to active interval value.
Alternate	Alternate interval value must be greater than or equal to alternate LOG interval value (LNK and RDS).	DFS3833 issued. Alternate interval value forced to alternate log interval value.
Alternate	Alternate interval value less than or equal to alternate RDS and LNK interval value (LOG only).	DFS3833 issued. Alternate interval value forced to alternate RDS then LNK interval value.
Alternate	Twice the interval value must be less than or equal to the alternate timeout value.	DFS3832 issued. Alternate timeout value forced to twice the interval value.
Active	Twice the interval value must be less than or equal to the active timeout value.	DFS3832 issued. Active timeout value forced to twice the interval value.

timeout

In the alternate subsystem, specifies how long (1 to 999 seconds) IMS waits for a new record, before considering a takeover.

When the alternate subsystem catches up with the active, the timeout and interval values are also used to determine a delay interval, which limits the frequency of calls to DBRC to check if an OLDS switch has occurred.

See [Table 75 on page 837](#) for additional information about coding the timeout value.

Table 75. Initializing the TIMEOUT value

Subsystem	Requirement	Exception action
Alternate	Timeout value must be greater than or equal to twice the alternate interval value.	DFS3832 issued. Alternate timeout value forced to twice the alternate interval value.
Active	Timeout value must be greater than or equal to twice the active interval value.	DFS3832 issued. Active timeout value forced to twice the active interval value.

wtime

Alternate IMS issues a warning message if the surveillance of active IMS is suspended longer than this value in seconds. Default is 0. This warning message is issued repeatedly with wtime interval while long delay condition continues. A /STO SURV ALL, LNK, LOG or RDS command will disable the warning message function. If this wtime is omitted or 0 is specified, no warning message is issued in XRF alternate IMS.

MNPS=name

Specifies the name of the MNPS ACB to use for terminal recovery. If specified, the USERVAR specification is ignored. This keyword is optional. If this specification is omitted, IMS uses the traditional XRF support and the USERVAR= specification for recovery.

MNPSPW=name

Specifies the password to use for the MNPS ACB. This password is checked by VTAM. If VTAM requires a password during VTAM system definition and no password is specified, then the MNPS ACB cannot be opened.

PSDEPAB=

Specifies whether (YES) or not (NO) prestarted BMP and IFP regions on the XRF alternate IMS are to be abnormally terminated with a U0454 abend during /STO BACKUP command processing on the alternate IMS, or /CHE FREEZE processing for the active IMS.

If NO is specified, the prestarted BMP and IFP regions are terminated with return code 0. The default is YES.

RDS=(interval,timeout,wtime)

Specifies the timing values for the restart data set (RDS) surveillance. The default is (1,3).

interval

In the active subsystem, specifies how often (1 to 99 seconds) IMS writes a time stamp on the RDS.

In the alternate subsystem, specifies how often (1 to 99 seconds) IMS checks for time stamps on the RDS.

See [Table 74 on page 837](#) for additional information about coding the interval value.

timeout

In the alternate subsystem, specifies how long (1 to 999 seconds) IMS waits for a time stamp before considering a takeover.

See [Table 75 on page 837](#) for additional information about coding the timeout value.

wtime

Alternate IMS issues a warning message if the surveillance of active IMS is suspended longer than this value in seconds. Valid values are 0 - 4294967295. The default is 0. This warning message is issued repeatedly with wtime interval while long delay condition continues. A /STO SURV ALL, LNK, LOG or RDS command will disable the warning message function. If this wtime is omitted or 0 is specified, no warning message is issued in XRF alternate IMS.

RSENAME=xxxxxxxx

Specifies the name of the recoverable service element (RSE) containing the active and alternate IMS subsystems in an XRF complex. The RSENAME= specifications must be the same in DFSHSBxx members for the active and alternate subsystems.

The name used for the RSENAME parameter should not be the same name used for the IMSID parameter in the IMSCTRL macro for either the active or the alternate IMS subsystems in the XRF complex.

RSENAME= is required.

SURV=

Specifies the surveillance mechanisms to run in an XRF complex. The SURV= parameters in the DFSHSBxx members for the active and alternate subsystems must be the same. The default is RDS,LOG,LNK.

RDS

The alternate subsystem is to periodically check for time stamps in the RDS.

LOG

The alternate subsystem is to periodically check for new log records in the IMS log.

LNK

The alternate subsystem is to periodically check for signals coming across the ISC link.

ALL

All three surveillance mechanisms are to be used.

SWITCH=

Controls if the failure of a surveillance mechanism, VTAM, or the IRLM should cause the alternate subsystem to consider a takeover.

ABEND

Active IMS terminates with ABENDU3305 when IRLM ABEND or VTAM failure occurs. Default is no ABEND.

LNK

The absence of signals across the ISL link after a timeout period elapses causes IMS to consider a takeover.

LOG

The absence of a new log record in the IMS log after a timeout period elapses causes IMS to consider a takeover.

RDS

The absence of a new time stamp in the RDS after a timeout period elapses causes IMS to consider a takeover.

IRLM

An IRLM failure causes IMS to request a takeover.

TPEND

A VTAM failure that invokes the IMS TPEND exit routine causes IMS to request a takeover.

Specifying SWITCH=(LNK,LOG,RDS),(IRLM),(TPEND) causes IMS to request a takeover for any one of the following events:

- The LNK, LOG, and RDS surveillance mechanisms all indicate a failure.
- The IRLM fails.
- VTAM fails and causes the IMS TPEND exit routine to be invoked.

USERVAR=xxxxxxxx

Specifies the USERVAR that VTAM uses to associate a logon message with the VTAM application name (APPLID) of the current active IMS subsystem in an XRF complex. The USERVAR= in DFSHSBxx members for the active and alternate subsystem must be the same.

USERVAR= is required if you have VTAM and are not using MNPS for XRF terminal switching.

When MNPS=*name* is specified, the USERVAR specification is ignored, and IMS uses MNPS for XRF terminal switching.

DFSINTxx member of the IMS PROCLIB data set

Use the DFSINTxx member of the IMS PROCLIB data set to identify the preinitialization modules to receive control before MPR, IFP, BMP, JMP, and JBP dependent regions are initialized.

Control statement

Usage

The record format is:

Position

Contents

1-71

Module names, separated by a comma. The last name on a record is denoted by a comma followed by one or more blanks; the last name on the last record is followed by one or more blanks.

72-80

Ignored

A separate control statement for each module is required.

Related reference

[Dependent Region Preinitialization routines \(Exit Routines\)](#)

DFSJVMAP member of the IMS PROCLIB data set

Use the DFSJVMAP member of the IMS PROCLIB data set to map uppercase Java application names that are specified to IMS.

This member maps all the 8-byte or less uppercase Java application names that are specified to IMS in one of the following ways with the OMVS path name for the IMS solutions for Java development application .class file:

- LANG=JAVA,GPSB= parm on the APPLCTN macro
- LANG=JAVA,PSB= parm on the PSBGEN macro
- MBR= parm on the DFSJBP procedure

DFSJVMAP pertains to JBP and JMP regions only. The member name must be DFSJVMAP.

DFSJVMAP is a member contained in a data set concatenated in the PROCLIB DD. A sample member DFSJVMAP is supplied in the IMS sample library. This member is optional and is read during dependent region application scheduling, thus, making this member dynamic. You do not need to bring down IMS when adding application name mappings to this member for the changes to take effect.

Comments are supported for this member and must begin with an asterisk (*) in the first column. Each line in this member must not be longer than 72 bytes. There must be no space between the equal sign (=) and the beginning of the pathname.

DFSJVMAP example 1

In this example, APPLCTN GPSB=JAVAPL1 was specified during IMS system generation, and javapl1.class exists in /usr/IMSjava/applications. You would specify the following in DFSJVMAP:

```
*****  
* Path name for JAVAPL1 *  
*****  
JAVAPL1=/usr/IMSjava/applications/javapl1
```

or

```
JAVAPL1=javapl1
```

DFSJVMAP example 2

In this example, APPLCTN PSB=JAVAPL2 was specified during IMS system definition and its corresponding PSBGEN macro was specified as PSBGEN LANG=JAVA,PSBNAME=JAVAPL2 and javapl2.class exists in /usr/IMSjava/applications. But javapl2.java contains the package statement package IMSjava.applications;. You would specify the following in DFSJVMAP:

```
*****  
* Path name for JAVAPL2 *  
*****  
JAVAPL2=IMSjava/applications/javapl2
```

You must code the following required JVM option either in the correct JVMOPMAS= member or, if you use the //STDENV DD statement, in the shell script that is referenced by the DD statement:

```
-Djava.class.path=/usr:...
```

DFSJVMEV (JVM environment settings member)

The DFSJVMEV member of the IMS PROCLIB data set is a sample member that is supplied in the IMS sample library (the SDFSMPPL data set). Use this member to specify the Java virtual machine (JVM) environment settings and to capture JVM usage statistics.

The DFSJVMEV member is contained in a data set that is concatenated in the PROCLIB DD. This member is optional and is read during dependent region application scheduling, thus, making this member dynamic. You do not need to bring down IMS for changes to this member to take effect.

When you use the //STDENV DD statement to define Java environment parameters and options, IMS ignores the DFSJVMEV member. Specify the Java configurations in the shell script that is referenced by the //STDENV DD statement when the statement is present.

Environment variables in the form of X=Y, where X is the environment variable and Y is the value of the environment variable, can be specified. For example, you can specify: JAVA_DUMP_OPTS=ONINTERRUPT (ALL) , ONANYSIGNAL (ALL) in the member, and IMS sets the environment variable JAVA_DUMP_OPTS to the value ONINTERRUPT (ALL) , ONANYSIGNAL (ALL) .

Comments are supported for this member and must begin with an asterisk (*) in the first column. Each line in this member must not be longer than 72 bytes. There must be no space between the equal sign (=) and the beginning of the path name. To mark the continuation of a line, place the greater-than sign (>) at the end of the line. Path name strings are restricted to 255 bytes. A path name string can be one path name or several path names that are separated by a colon (:). The portion of the path name string greater than 255 bytes is ignored.

To use the DFSJVMEV member to capture JVM usage statistics, specify the **JLEOPT=N** parameter to indicate that a persistent JVM is used for the IMS dependent region. You must also use the **SMFINTERVAL** parameter to specify the time interval in milliseconds that is used to log JVM statistics. 6000 is the recommended value.

Parameters

CANCEL_PGM=Y | N(,EXCLUDE=proclib_member_name)(,APPTERMEXIT=exit_name)

Specifies whether (Y) or not (N) you want IMS to 'clean up' your COBOL programs and subprograms per commit cycle and across application program schedules. The default is N.

If CANCEL_PGM=Y is specified, IMS ensures that the next time the referenced program or subprogram is called, it will be entered in its initial state. In addition, all programs that are contained within the program being canceled are also canceled such that the working storage areas will be cleaned up for the next program execution.

Note: If the **CANCEL_PGM=Y** parameter is specified, the program modules that are specified on the DFSMPLxx member are deleted from working storage areas after the program has run. For the program modules that are specified on the DFSMPLxx member to remain loaded when **CANCEL_PGM=Y** is specified, use the **EXCLUDE=proclib_member_name** parameter with **CANCEL_PGM=Y** to exclude the program modules from the delete process.

If CANCEL_PGM=N is specified or is allowed to default to N, IMS will not 'clean up' the program and all its subprograms that it invoked during execution such that the working storage areas will remain intact for the next program execution.

For CANCEL_PGM=Y:

- An optional exclude list can be specified in the form CANCEL_PGM=Y,EXCLUDE=proclib_member_name. The user can specify (sub)program names in this list to have IMS exclude the named (sub)programs from the cancel process. All other (sub)programs that are not specified in the list will be canceled. The exclude list is a PROCLIB member. Each name specified in the list must be on a separate line. You can specify comments in the list by placing an asterisk (*) in the first column. You can specify a maximum of 100 (sub)program names.

- An optional user exit can be specified in the form `CANCEL_PGM=Y,APPTERMEXIT=exit_name`. This user exit is invoked after the program has terminated and returned to IMS, but before the 'clean up' process is initiated as described by the `CANCEL_PGM=Y` option. This user exit must be written in a Language Environment conforming language such as COBOL or assembly language. This user exit is given control by IMS in the Language Environment enclave that is created for the Persistent JVM environment. The value that is specified for `exit_name` must be between one and eight bytes. As a usage example, this exit can be used to 'clean up' any LE HEAP storage used by the program environment.
- Both `EXCLUDE=` and `APPTERMEXIT=` can be specified at the same time separated by commas and in either order. For example, you can specify either of the following:

```
CANCEL_PGM=Y,EXCLUDE=member_name,APPTERMEXIT=exit_name
CANCEL_PGM=Y,APPTERMEXIT=exit_name,EXCLUDE=member_name
```

DB2JCC_CONN_REUSE= Y | N

Specifies whether (Y) or not (N) you want IMS to communicate to DB2 JCC that the DB2 JCC connection should be reused if possible for the next transaction. The default is N.

This option is recognized only for MPP, BMP, and IFP regions.

Note: If `DB2JCC_CONN_REUSE=Y` is specified, the DB2 JCC connection will be reused only if the transaction user ID for the next transaction is the same as the userid for the previous transaction.

Restriction: If `DB2JCC_CONN_REUSE=Y` is specified in the IMS dependent region ENVIRON member for an MPP/BMP/IFP, IMS and DB2 JCC provide connection reuse across unit of recovery (UOR) boundaries in a scheduled application. After the application is unscheduled, the DB2 JCC connections that are obtained within it are not eligible for reuse.

There can be multiple UORs within a unit of work (UOW). A UOW boundary occurs when an application is unscheduled because the application goes through termination.

If `DB2JCC_CONN_REUSE=Y` is specified and any of the following is true, DB2 JCC connection reuse will not occur:

- A `PROCLIM=0|1` setting for a transaction results in a single UOR, regardless of a message GU loop. The application immediately goes through termination, resulting in a new UOW and negating any connection reuse.
- Not having multiple UORs within a scheduled application. This translates to not having a message GU loop because each message GU results in a UOR.
- A different user ID is associated with a subsequent UOR. In this case, the connections must be reestablished for security purposes.

JLEOPT= Y | N

Specifies whether (Y) or not (N) you want IMS to terminate the IBM Language Environment for z/OS (LE) enclave and reinitialize the Language Environment enclave after each application program schedule. This would enable (or not) the Language Environment dynamic runtime parameter overrides for each application program that is scheduled in the dependent region.

LIBPATH=

Required variable that must specify the environment variable. There must not be a space between the equal sign (=) in the `LIBPATH=` and the beginning of the first path name.

The `LIBPATH=` parameter must contain a list of directories, separated by colons, that includes the locations of:

- The `libjvm.so` or the `libjvm31.so` (31/64-bit interoperability) and `libwrappers.so` libraries (DLLs).
- The Java class libraries for IMS (`libT2DLI.so`).

The `LIBPATH=` must point to the Java runtime libraries that match the addressing mode specified on the `JVM=` parameter of the dependent region procedure: 31-bit Java installation for `JVM=31`, and 64-bit Java installation for `JVM=64` or `JVM=3164`.

SMFINTERVAL=

Specifies the time interval in milliseconds that is used to log JVM statistics. The statistics are logged in z/OS SMF as a type-29, subtype-2 record. 6000 is the recommended value.

UMASK=xxx

Specifies the umask value to set the file permission bits when you create files in JVM for the persistent JVM dependent region, such as Java Message Processing (JMP) regions or Message Processing Program (MPP) regions.

xxx is a 3-digit octal number, for example, UMASK=002 or UMASK=644. The default umask value is specified in the `/etc/profile` system configuration file. For more information about the umask values, see the *z/OS UNIX System Services User's Guide*.

ESAF_SIGNON_ACEE= YES | NO

Specifies whether (YES) or not (NO) you want the IMS system to create the accessor environment element (ACEE) to be passed to the external subsystem (ESS) during External Subsystem Attach Facility (ESAF) signon processing. The default is NO.

If YES is specified, the following conditions occur:

- The IMS system creates and manages the ACEE in a persistent Java virtual machine (JVM) dependent region for ESAF thread instead of the ESS creating and managing the ACEE for every ESAF call.
- The IMS system creates the ACEE only once for the ESAF thread commit cycle and passes the ACEE to the ESS through the Signon exit routine.
- The ACEE is used only within the ESS and is not used for any other processing that the ESAF thread performs. For example, you can specify `ESAF_SIGNON_ACEE=YES` in a SECURE OTMA CHECK environment, while the SECURE OTMA CHECK specification is still valid in all processing that is unrelated to the ESS.
- When this function is enabled for the dependent region, message DFS549I is issued.

DB2JCC_ESAF_THREAD_NOTIFICATION= YES | NO

Specifies whether (YES) or not (NO) you want the IMS system to inform DB2 for z/OS JCC driver of the ESAF thread in process in any application that executes in the IMS dependent region. The default is NO. If you specify YES, you must also set the external subsystem module table (ESMT) to **DSNMIN20** in the **SSM=** parameter. Learn more at [SSM= parameter for procedures \(System Definition\)](#).

YES must be specified if the application that executes in the IMS dependent region is issuing JCC calls and DB2 IMS attachment connection pooling is enabled between Db2 for z/OS and the IMS system.

If YES is specified, DB2 JCC can reuse prepared statements for the ESAF thread in a DB2 ESAF connection pooling environment.

DFSJVMEV example

In the following DFSJVMEV example, the first two paths that are specified point to the Java Version 7.0 runtime libraries that are located in the z/OS UNIX System Services file system. The third path specifies the location of the `libT2DLI.so` file, which points to the Java native code for IMS type-2 Java connectivity. The `libT2DLI.so` file is created in the UNIX System Services file system when running the IMS Installation Verification Program for Java scenarios.

```
*****
* Specify the location of 31-bit Java Virtual Machine (JVM)
* installation and IMS Java native code (libT2DLI.so)
*****
LIBPATH=>
/javaroot/java170/J7.0/lib/:>
/javaroot/java170/J7.0/lib/s390/j9vm:>
/usr/lpp/ims/lib
```

For dependent regions that are started with JVM=64 or JVM=3164, the LIBPATH= must point to the 64-bit Java runtime libraries. For JVM=3164 the minimum requirement is Java 8.

```
*****
* Specify the location of the 64-bit Java Virtual Machine (JVM)
* installation (libjvm.so or libjvm31.so) and IMS Java native
* code (libT2DLI.so)
*****
LIBPATH=>
/javaroot/java180/J8.0_64/lib:>
/javaroot/java180/J8.0_64/lib/s390x/j9vm:>
/usr/lpp/ims/lib
```

Related information

[Supercharge IMS Business Applications with Java](#)

DFSJVMMS member of the IMS PROCLIB data set

You can use the DFSJVMMS member of the IMS PROCLIB data set to specify JVM options for the standalone JVM for JBP regions.

When you use the //STDENV DD statement to define Java environment parameters and options, IMS ignores the DFSJVMMS member. Specify the Java configurations in the shell script that is referenced by the //STDENV DD statement when the statement is present.

This is a sample member that demonstrates how to specify JVM options for the standalone JVM for JBP regions.

To define the JVM options:

1. Specify the **-Xoptionsfile** option to point to the UNIX System Services (USS) file system JVM properties file. The **--Xoptionsfile** option allows you to specify path names that are greater than 255 characters in length on the **-Djava.class.path** option.
2. Specify the **-Djava.class.path** option in the options file to specify the application class path.

Alternatively, you can specify the following directly in the member:

- `-Djava.class.path=<application class path>`

Specify the path name (or path names) of your Java application class files. If your .class files are contained in a .jar file, the path name to the .jar file must be fully qualified, including the name of the .jar file.

Comments are supported for this options member. The comments begin with an asterisk (*) in the first column.

Each line in the options file must not be longer than 72 bytes, including the continuation mark. Use a greater-than symbol (>) at the end of the line as a continuation character.

If you do not use the **-Xoptionsfile** JVM option, path strings can be a maximum of 255 bytes (any characters over 255 bytes are ignored). A path string can be one path name or several path names. If you are specifying multiple path names, separate each by a colon (:).

For information about how this member is specified in IMS procedures, see the [“JVMOPMAS=name parameter for procedures”](#) on page 549 topic.

Examples

If your USS file system JVM options file is located at /u/USRID01/myjava/options, the **-Xoptionsfile** option would be set as follows:

```
-Xoptionsfile=/u/USRID01/myjava/options
```

The file located at /u/USRID01/myjava/options might contain the following content:

```
-Djava.class.path=\
/u/ims/usr/lpp/ims/imsXX/imsjava/imsudb.jar:\
```

```
/u/ims/usr/lpp/ims/imsXX/imsjava/imsutm.jar:\
/path/to/yourJavaApp.jar
-Xmx128M
```

Note that a backslash (\) is used at the end of the line as a continuation character.

You can also specify the JVM options directly in the DFSJVMMS member:

```
-Djava.class.path=>
/u/ims/usr/lpp/ims/imsXX/imsjava/imsudb.jar:>
/u/ims/usr/lpp/ims/imsXX/imsjava/imsutm.jar:>
/path/to/yourJavaApp.jar
-Xmx128M
```

Note that a greater-than symbol (>) is used at the end of the line as a continuation character.

DFSMPLxx member of the IMS PROCLIB data set

Use the DFSMPLxx member of the IMS PROCLIB data set to make z/OS, IMS, or user-written program modules that are not automatically preloaded into the IMS control region resident in IMS regions.

Making some modules resident can improve throughput and response time for transactions frequently referred to if sufficient virtual storage is available with high-performance paging DASD. Ordinarily, preloading modules is advantageous only for MPPs and for message-driven Fast Path regions, and only when the preloaded modules are reentrant.

Notes:

- If **CANCEL_PGM=Y** is specified, the program modules that are specified on the DFSMPLxx member are deleted from working storage areas after the program has run. For the program modules that are specified on the DFSMPLxx member to remain loaded when **CANCEL_PGM=Y** is specified, use the **EXCLUDE=proclib_member_name** parameter with **CANCEL_PGM=Y** to exclude the program modules from the delete process.
- Pseudo wait- for-input (PWFI) and wait-for-input (WFI) application programs that are resident in IMS dependent regions cannot be refreshed dynamically. For details, see the **UPDATE PGM** command.

Program modules can be made resident in either an IMS region or LINKPACK. This topic explains how to make program modules permanently resident and provide some rules for doing so.

Making modules resident in a region

When making modules resident in a region, consider the following:

- Only serially reusable z/OS, IMS, or user-written program modules can be resident in a region.
- Only program modules used for transactions serviced by the region involved, should be made resident in that region. Program modules should be resident for only the duration of the region.
- z/OS and IMS modules that execute in a dependent region can reside in that dependent region.

Modules made resident in a region are in the region JOBPack and are called without repeating the overhead of searching STEPLIB/JOBLIB, LINKPACK, and SYS1.LINKLIB. The overhead of fetching the module into virtual storage is encountered only at region initialization time.

Making modules resident in LINKPACK

In an operating environment where there are several batch regions or a combination of online and batch regions, it can be advantageous to place some of the frequently used IMS and access method modules in the operating system LPA. Programs made resident in LPA should be those that can be shared among all regions. This saves virtual storage space. The modules to be included must exist in either a LNKSTxx member of SYS1.PARMLIB (or its concatenations, one of which should be IMS.SDFSRESL) or SYS1.SVCLIB.

Initial access of LPA resident program modules can be slow, because the region JOBPack and STEPLIB/JOBLIB are searched before LPA is searched. Subsequent access can be at CPU speeds if the region JOBPack has not been purged by z/OS virtual storage management (as when sufficient virtual storage is not available to satisfy a user GETMAIN for space). Although the modules are physically residing in LPA (and are shared among multiple regions), the overhead involved in searching program libraries and LPA is only experienced at region initialization time.

Although some real storage can be saved by putting the DL/I action modules into LPA, it is not recommended that an installation place IMS modules into the LPA. Doing so makes it difficult to execute different versions of IMS concurrently. Also, when maintenance is applied to modules in LPA, another initial program load of the z/OS system is required.

The IMS module preload function

The z/OS task under which modules are preloaded varies based on the IMS region type. [Table 76 on page 846](#) shows IMS region types and associated z/OS tasks.

Table 76. IMS region types and associated z/OS tasks

IMS region type	z/OS task
Control (CTL)	Physical Log
Message (MSG) non-reentrant modules	Program Control
Message MSG reentrant modules	Region Control
Batch Message (BMP)	Region/Program Control
Batch (DLI)	Region/Program Control
Fast Path (IFP)	Region/Program Control
Java batch processing region (JBP region)	Region/Program Control
Java message processing region (JMP region)	Region/Program Control

Control statement

Complete the following steps to use this function to make program modules resident in a region or LINKPACK.

1. Use the IMS PROCLIB data set allocated before Stage 2 of IMS system definition and the z/OS utility IEBUPDTE to create members of the IMS PROCLIB data set that identify modules to be preloaded.

Related reading: See *z/OS MVS Data Administration: Utilities*.

Member names must be DFSMPLxx. The record format is:

Position

Contents

1-71

Module names, separated by a comma

72-80

Ignored

The first name on a record can have leading blanks. The last name on a record is denoted by a comma followed by one or more blanks; the last name on the last record is followed by one or more blanks.

No limit exists for the number of module names that can be specified. If a preloaded module has ALIAS names that are ordinarily invoked by z/OS LINK (that is, application programs in DLI BMPs and MPPs), those ALIAS names should also be specified for preload.

2. Bind the application program modules using the IMS reentrant DL/I language interface. The true attributes must be specified; for example, if reusable only, do not specify "RENT."

The IMS DL/I language interface is not reentrant. Any IMS application programs that were designed to be reentrant or serially reusable can use the module preload function after being bound with the IMS language interface.

3. In the step execution JCL, do both of the following:

- Insert a DD statement for IMS.PROCLIB with the ddname PROCLIB.
- Specify the correct member of the IMS.PROCLIB data set in the EXEC statement parameter.

If an invalid member name is specified, or if the record format is incorrect, no modules are loaded but a message is issued and initialization continues.

The member name should be unique unless overridden by the IMS procedure.

For a description of the EXEC statement parameters, see [“DFSMPR procedure” on page 626](#).

Related reference

[UPDATE PGM command \(Commands\)](#)

DFSORSxx member of the IMS PROCLIB data set

Use the DFSORSxx member of the IMS PROCLIB data set to define system-related startup parameters for the recovery manager in a DBCTL or DB/DC online environment.

This member is identified by the ORSMBR parameter in the EXEC statement. If the DFSORSxx member of the IMS PROCLIB data set is not provided, the installed recovery service is initiated with default values.

Related reading:

- For information about tailoring the DFSORSxx member for use with the IMS Database Recovery Facility V2 product, see *IMS Database Recovery Facility for z/OS User's Guide*.

DFSPBxxx member of the IMS PROCLIB data set

Use the three forms of the DFSPBxxx member of the IMS PROCLIB data set, DFSPBDBC, DFSPBDCC, and DFSPBIMS, to specify execution parameters for the DBCTL, DCCTL, and DB/DC control regions, respectively.

Each DFSPBxxx member of the IMS PROCLIB data set controls a different IMS environment:

DFSPBDBC

DBCTL environment

DFSPBDCC

DCCTL environment

DFSPBIMS

DB/DC environment

You can use the IMS Syntax Checker to modify these members of the IMS PROCLIB data set.

The DFSPBxxx member consists of one or more 80-character records. Only characters 1-71 are used as input. Data in characters 72-80 is ignored. A parameter must be specified in its entirety on a single line. You cannot continue to the next line to complete the parameter specification.

Each record contains either:

- A comment, marked by an '*' in statement column 1.
- One or more execution parameters in the following form:

```
KEYWORD=value
```

The parameters are separated by commas (,). Each parameter can be preceded by a space or the comma following the prior parameter value. You can have blanks on either, both, or neither side of the comma that separates keyword strings.

- One execution parameter

```
KEYWORD=value
```

followed by a comment. The comment is separated from the parameter by one or more blanks. A comment may contain any characters except the equal sign (=).

Example:

```
AUTO=,
```

DFSPBDBC

This member applies only to a DBCTL environment. It allows you to specify DBCTL control region execution parameters. The parameters that you specify in this member override those specified in the stage 1 macros.

You can place several DFSPBDBC members in the IMS PROCLIB data set by replacing the member name DFSPBDBC with DFSPBxxx, where xxx must be three alphanumeric characters. The RGSUF= keyword in the DBC procedure specifies the xxx suffix to be used during startup of the DBCTL control region.

For a list of parameters associated with DFSPBDBC, see [“DBC procedure” on page 604](#). For a list of parameter descriptions, see [“Parameter descriptions for IMS procedures” on page 520](#).

DFSPBDCC

This member applies only to a DCCTL environment. It allows you to specify DCCTL control region execution parameters. The parameters that you specify in this member override those specified in the stage 1 macros.

You can place several DFSPBDCC members in the IMS PROCLIB data set by replacing the member name DFSPBDCC with DFSPBxxx, where xxx must be three alphanumeric characters. The RGSUF= keyword of the DCC procedure provides the xxx suffix to be used during startup of the DCCTL control region.

For a list of parameters associated with DFSPBDCC, see [“DCC procedure” on page 611](#). For a list of parameter descriptions, see [“Parameter descriptions for IMS procedures” on page 520](#).

DFSPBIMS

This member applies only to a DB/DC environment. It allows you to specify DB/DC control region execution parameters. The parameters that you specify in this member override those specified in the stage 1 macros.

You can place several DFSPBIMS members in the IMS PROCLIB data set by replacing the member name DFSPBIMS with DFSPBxxx, where xxx must be three alphanumeric characters. The RGSUF= keyword of the IMS procedure provides the xxx suffix to be used during startup of the DB/DC control region.

For a list of parameters associated with DFSPBIMS, see [“IMS procedure” on page 639](#). For a list of parameter descriptions, see [“Parameter descriptions for IMS procedures” on page 520](#).

Related concepts

“IMS Syntax Checker” on page 381

The Syntax Checker is an ISPF application that helps you define, verify, and validate parameters and their values in the members of the IMS PROCLIB data set. Use the IMS Syntax Checker to avoid typographical and syntactical errors when modifying the parameter values for the IMS PROCLIB data set members.

DFSSPMxx member of the IMS PROCLIB data set

Use the DFSSPMxx member of the IMS PROCLIB data set to override the default buffer definitions for the storage pools managed by the DFSPool storage manager.

The storage pools that are managed by the DFSPool storage manager include:

- AOIP
- CESS
- CIOP
- CMDP
- DYNP
- EMHB
- FPWP
- HIOP
- LUMC
- LUMP

xx is the 2-character suffix specified in the SPM= startup parameter.

Default storage pool definitions are generated by IMS. Each definition contains information about the pool including the default buffer definitions.

Storage pool	Where the pool is allocated
AOIP	Extended private
CESS	Subpool 231 ECSA
CIOP	24-bit private
CMDP	Extended private
DYNP	Extended private
EMHB	Subpool 231 ECSA
EPCB	Subpool 231 ECSA
FPWP	Extended private
HIOP	Extended private
LUMC	Subpool 231 ECSA
LUMP	Extended private

The buffer size definitions contain the buffer sizes that the storage manager is allowed to choose from when allocating a buffer from the pool. For each buffer size, the definition specifies how many buffers to obtain in the primary block, how many buffers to obtain in secondary blocks, and whether to obtain the primary block when the pool is allocated. If the primary block is obtained during initialization, it is not released during compression.

Syntax

→ FPL=*poolname* , (*size,pbuf,sbuf,init*) →

Restrictions

If you establish an FDBR region, all pool names that you specify are ignored. The FDBR region internally specifies the following values for all pools regardless of whether they are explicitly specified by the control statements or defined as default in the system definition process:

- 2** Number of buffers in the primary storage allocation
- 2** Number of buffers in secondary storage allocation
- N** Primary storage allocation during IMS initialization =

Usage

The buffer definitions shown in [Table 78 on page 850](#) are the existing default definitions.

For all pools, 16 bytes are added to the buffer sizes for prefix and suffix information. For AOIP, CIOP, CMDP, HIOP, EMHB, LUMP, LUMC, and SPAP pools, an additional 8 bytes are added for the overlay detection constant.

IMS Fast Path (IFP) dependent regions also use EMHB pools. IFP dependent regions use a value equal to the largest EMHB as the value for the EPSTESRT buffer. This amount of storage is used in addition to the number of buffers in the primary or secondary storage allocation that you define for EMHB pools in member DFSSPMxx. For example, if you had 100 terminals using 1 buffer of primary storage each, then you would specify 100 as the number of buffers in the primary storage allocation. But if you also had 50 IFP dependent regions using EMHB, the actual number of buffers used in the primary storage would be 150.

For EMHB, the buffer size includes the prefix and data portion. For information about the prefix length, see the EMHBHL field of the expedited message handler block control block that is mapped by the DBFEMHB macro.

AOIP								
	Buffer 1	Buffer 2	Buffer 3	Buffer 4	Buffer 5	Buffer 6	Buffer 7	Buffer 8
Size	48	132	256	576	1048	2096	4192	32 768
Primary Allocation	50	500	100	32	16	8	4	4
Secondary Allocation	50	1500	100	32	8	4	2	2
Obtain primary allocation?	Yes	No	No	No	No	No	No	No

CIOP								
	Buffer 1	Buffer 2	Buffer 3	Buffer 4	Buffer 5	Buffer 6	Buffer 7	Buffer 8
Size	256	512	1024	2048	4096	8192	16 384	32 768

CIOP								
Primary Allocation	64	32	32	32	16	8	4	4
Secondary Allocation	32	16	16	16	8	4	2	2
Obtain primary allocation?	Yes	No	No	No	No	No	No	No

CMDP, EMHB								
	Buffer 1	Buffer 2	Buffer 3	Buffer 4	Buffer 5	Buffer 6	Buffer 7	Buffer 8
Size	256	512	1024	2048	4096	8192	16 384	32 768
Primary Allocation	64	64	32	32	16	8	4	4
Secondary Allocation	32	32	16	16	8	4	2	2
Obtain primary allocation?	No	No	No	No	No	No	No	No

CESS								
	Buffer 1	Buffer 2	Buffer 3	Buffer 4	Buffer 5	Buffer 6	Buffer 7	Buffer 8
Size	128	256	512	1024	2048	4096	8192	16 384
Primary Allocation	32	32	32	32	32	16	8	4
Secondary Allocation	16	16	16	16	16	8	4	2
Obtain primary allocation?	Yes	No	No	No	No	No	No	No

DYNP									
	Buffer 1	Buffer 2	Buffer 3	Buffer 4	Buffer 5	Buffer 6	Buffer 7	Buffer 8	Buffer 9
Size	256	512	768	1024	2048	3072	4096	8192	32768
Primary Allocation	32	32	32	32	16	12	8	4	4
Secondary Allocation	16	16	16	16	8	12	8	2	2
Obtain primary allocation?	No	No	No	No	No	No	No	No	No

FPWP								
	Buffer 1	Buffer 2	Buffer 3	Buffer 4	Buffer 5	Buffer 6	Buffer 7	Buffer 8
Size	25	51	102	2048	4096	8192	16 384	32 768
Primary Allocation	6	6	3	32	16	8	4	4
Secondary Allocation	3	3	1	16	8	4	2	2
Obtain primary allocation?					No	No	No	No

HIOP									
	Buffer 1	Buffer 2	Buffer 3	Buffer 4	Buffer 5	Buffer 6	Buffer 7	Buffer 8	Buffer 9
Size	256	512	1024	2048	4096	8192	16 384	32 768	65 536
Primary Allocation	64	64	32	32	16	8	4	4	4
Secondary Allocation	32	32	16	16	8	4	2	2	2
Obtain primary allocation?	No	No	No	No	No	No	No	No	No

LUMC								
	Buffer 1	Buffer 2	Buffer 3	Buffer 4	Buffer 5	Buffer 6	Buffer 7	Buffer 8
Size	128	256	512	1024	2048	3064	4096	33 024
Primary Allocation	32	32	32	32	16	12	8	4
Secondary Allocation	32	16	16	16	8	12	8	2
Obtain primary allocation?	No	No	No	No	No	No	No	No

LUMP											
	Buffer 1	Buffer 2	Buffer 3	Buffer 4	Buffer 5	Buffer 6	Buffer 7	Buffer 8	Buffer 9	Buffer 10	Buffer 11
Size	128	256	512	1024	2048	3064	4096	5120	33024	38144	65536
Primary Allocation	32	32	32	32	16	12	8	8	4	8	4

LUMP											
Secondary Allocation	32	16	16	16	8	12	8	8	2	8	2
Obtain primary allocation?	No	No	No	No	No	No	No	No	No	No	No

You can define a maximum of 32 different buffer sizes that can be used to satisfy requests for storage. The size of the buffer that is used to satisfy a request is determined on a "best-fit" basis.

The FPL= statement is used to specify buffer definition overrides. Multiple buffer definitions are allowed on a single statement. You can have one or more FPL= statements within the DFSSPMxx member. If the member contains more than 32 buffer definitions for a single pool, only the first 32 are used. Remaining definitions are ignored.

DFSSPMxx is not required to initialize IMS. It is intended only to override existing IMS storage pool definitions; therefore, no default member is supplied.

If an FPL= is incorrectly specified, message DFS0639W is issued. One message is issued for each occurrence of an invalid parameter.

Parameters

FPL=

Is the required keyword for IMS storage pool buffer override definitions. This keyword must be in position 1. The FPL= statement cannot be continued; however, more than one statement is allowed per pool.

poolname

Is the four-character name of the IMS storage pool. The valid names are:

AOIP
CESS
CIOP
CMDP
DYNP
EMHB
FPWP
HIOP
LUMC
LUMP

size

Specifies the buffer size, in bytes. The value must be a one- to five-digit number between 8 and 65536. The buffer size is rounded up to the next multiple of 8. If the rounded value is not unique, it is discarded. You can specify values in 1K increments; that is, 1K, 2K, 3K, up to 64K.

pbuf

Specifies the number of buffers in the primary storage allocation. The value must be a one- to five-digit number between 2 and 65535. If the size of the primary allocation exceeds the upper expansion limit, the default is 2.

sbuf

Specifies the number of buffers in secondary storage allocations. The value must be a one- to five-digit number between 2 and 65535. If the size of the primary allocation exceeds the upper expansion limit, the default is 2.

init

Specifies whether (Y) or not (N) the primary storage allocation is obtained during IMS initialization. If the primary storage allocation is not obtained during initialization, it is not obtained until it is necessary to satisfy a buffer request. If an upper expansion limit is specified for the pool, and the size of either the primary or secondary storage allocation exceeds the upper expansion limit, the upper expansion limit is set to the default value of 2G-1.

Examples

The following are examples of how the DFSSPMxx member of the IMS PROCLIB data set can be used to override the default buffer definitions for the CIOP pool.

```
FPL=CIOP,(248,20,15,Y),(500,20,10,N),(1016,15,8,Y)
FPL=CIOP,(2040,15,8,N),(4088,10,5,N),(8184,10,5,N)
FPL=CIOP,(16K,8,4,N),(32K,4,2,N)
```

The buffer sizes being defined range from 248 to 32 768 (32K) bytes. Each buffer size is rounded up to the next multiple of 8, and 8 bytes are added for internal processing. [Table 79 on page 854](#) shows the values used by the Storage Manager when allocating CIOP storage for the definition in the example.

Table 79. Primary and secondary buffer allocations

Buffer size	Primary buffer allocation	Secondary buffer allocation	Obtain primary allocation?
256	20	15	Y
512	20	10	N
1024	15	8	Y
2048	15	8	N
4096	10	5	N
8192	10	5	N
16392	8	4	N
32776	4	2	N

DFSSQxxx member of the IMS PROCLIB data set

Use the DFSSQxxx member of the IMS PROCLIB data set to specify parameters related to the shared message queues and the CQS address space in DB/DC and DCCTL environments.

You can find an example of the DFSSQxxx member of the IMS PROCLIB data set, DFSSQ999, in library SDFSSLIB.

The parameters for DFSSQxxx can also be specified on the DFSDFxxx member of the IMS PROCLIB data set. See [“DFSDFxxx member of the IMS PROCLIB data set” on page 756](#) for more information.

Syntax

You can use the IMS Syntax Checker to modify this member of the IMS PROCLIB data set.

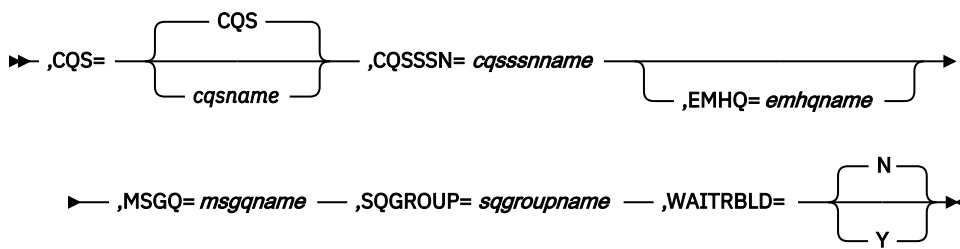

Usage

A DFSSQxxx member consists of one or more fixed-length character records (the configuration data set can be of any LRECL greater than eight, but it must be fixed record format). The rightmost-eight columns are ignored but can be used for sequence numbers or any other notation. Keyword parameters can be coded in the remaining columns in free format, and can contain leading and trailing blanks. You can specify multiple keywords in each record; use commas or spaces to delimit keywords. Statements that begin with a “*” or “#” in column 1 are comment lines and are ignored. Additionally, comments can be included anywhere within a statement by enclosing them between “/* ” and “*/”, for example, /* PROCLIB comments */. Values coded in this member of the IMS PROCLIB data set are case sensitive. In general, you should use uppercase for all parameters.

Errors encountered during DFSSQxxx member processing cause IMS initialization to terminate.

Parameters

CQS=

Specifies the one- to eight-character name of the member of the IMS PROCLIB data set that contains one of the following:

- The procedure for the CQS address space.

When shared message queues are requested the IMS control region automatically starts the CQS procedure during IMS initialization. The default procedure name is CQS.

- The START command.

The START command begins in column 1 with the characters START. The START command and its parameters must not extend beyond column 71.

When shared message queues are requested, the IMS control region issues the user-specified START command to start the CQS address space.

CQSSSN=

Specifies the name for the CQS address space. The value must be 1 - 4 alphanumeric characters. IMS uses this name to connect to the proper CQS address space. When connecting IMS to CQS, you must specify the same value on CQSSSN= and on the SSN= parameter of the CQSIPxxx member of the IMS PROCLIB data set for the target CQS. The parameter is required and no default exists.

As many as 32 different IMS control regions can specify the same CQSSSN= parameter.

EMHQ=

An optional parameter that specifies the 1- to 16-character name of the primary structure that contains the shared expedited message handler queues (EMHQs). In a shared-queues environment when Fast Path is installed, the presence of this statement indicates that the EMHQ structure, along with its associated log structure, checkpoint data set, and structure recovery data set are required. To disable shared expedited message handler processing, you can remove the EMHQ statement from this member, and the EMHQ structure, along with its associated log structure, checkpoint, and structure recovery data sets, are not required.

If you do not want to utilize an EMHQ structure for an IMS system, you need to delete the STRUCTURE statement for the EMHQ from the CQSSLxxx member of the IMS PROCLIB data set. If you do not

want to utilize an EMHQ structure for all the IMS systems in a sysplex, you also need to delete the STRUCTURE statement for the EMHQ from the CQSSGxxx member of the IMS PROCLIB data set.

When you do not use an EMHQ structure, you should also do the following:

- In the CRFM policy, delete the STRUCTURE definitions for the EMHQ structure and its CQS log.
- In the z/OS Logger Structure Definition policy, delete the LOGSTREAM definition for CQS log for an EMHQ structure.
- If you are using an IMS automation program for any command that deals with an EMHQ structure, delete the command in the automation.

If you specify an EMHQ= structure, you must

- specify shared message queues on the MSGQ= parameter.

IMS requires the message queues to process system messages that result from Fast Path activity. If the EMH queues are built in a coupling facility structure, the message queues must also be in a structure.

- Specify FP=Y as a control region execution parameter.

The name you specify for EMHQ= must not be the same as the name you specify for MSGQ=. The name must also be specified to CQS on the STRNAME= parameter in the CQSSLxxx and CQSSGxxx members of the IMS PROCLIB data set.

This parameter is valid only when Fast Path is installed.

MSGQ=

Specifies the one- to sixteen-character name of the primary structure that contains the shared message queues. If the message queues are built in a coupling facility structure, the EMH queues, if used, must also be in a structure.

The name you specify for MSGQ= must not be the same as the name you specify for EMHQ=. The name must also be specified to CQS on the STRNAME= parameter in the CQSSLxxx and CQSSGxxx members of the IMS PROCLIB data set.

SQGROUP=

Specifies a one- to five- character identifier. IMS concatenates this identifier to DFS to create the z/OS cross-system coupling facility IMS shared queues group name. You must specify the same identifiers for all IMS subsystems that share the same set of structures. You can use the same identifier for the CQSGROUP= parameter in the CQSIPxxx member of the IMS PROCLIB data set. This parameter is required and there is no default.

WAITRBLD=Y|N

Specifies whether activity against the EMHQ structure waits while the structure is being rebuilt. If you specify Y (yes), all activity against the EMHQ structure waits until the structure rebuild completes. If you specify N (no), activity against the EMHQ structure continues while CQS rebuilds the structure.

The value specified for this keyword remains in effect for the life of the structure and cannot be changed.

Restriction: This parameter does not apply to the MSGQ. The MSGQ must wait for rebuild to complete before activity can resume.

If you change the WAITRBLD= parameter, you must first deallocate the fast path structure.

Related concepts

[“IMS Syntax Checker” on page 381](#)

The Syntax Checker is an ISPF application that helps you define, verify, and validate parameters and their values in the members of the IMS PROCLIB data set. Use the IMS Syntax Checker to avoid typographical and syntactical errors when modifying the parameter values for the IMS PROCLIB data set members.

DFSVSMxx member of the IMS PROCLIB data set

Use the control statements in the DFSVSMxx member of the IMS PROCLIB data set to define settings for buffer pools, trace options, coupling facility structures, IRLM lock timeout, and transactions in a HALDB partition.

In an IMS batch system, these control statements are put in a data set with ddname DFSVSAMP. The data set must contain blocked or unblocked 80-character records.

Recommendation: Do not place DFSVSAMP in the same PDS as your user application files. This causes batch jobs to abend with ABEND0C4 in DFSRTM00.

In an IMS online system, these control statements are put in the IMS.PROCLIB data set in member DFSVSMxx. The VSPEC symbolic parameter in the IMS, DBC, and DCC procedures is used to specify the suffix (xx) of the DFSVSMxx member to be used. During stage 2, IMS creates a default member with suffix 00. If a suffix is not specified on the startup procedure, the default member is used. The default values are also used if the control statements in the startup procedure are missing or invalid.

The control statements in this member are processed during IMS initialization. The control statements allow you to perform various tasks.

Table 80. DFSVSMxx parameters for Online IMS that can be specified in IMS batch jobs via DFSVSAMP DD.

DFSVSMxx member of the IMS PROCLIB dataset	DFSVSMxx	DFSVSAMP
Defining Fast Path DEDB buffer pools for single-area structures	Yes	No
Defining Fast Path DEDB buffer pools for multi-area structures	Yes	No
Defining VSAM buffer pools	Yes	Yes
Defining VSAM subpools	Yes	Yes
Defining VSAM performance options	Yes	Yes
Defining OSAM subpools	Yes	Yes
Requesting that z/OS dynamic allocation use extended storage	Yes	No

Table 80. DFSVSMxx parameters for Online IMS that can be specified in IMS batch jobs via DFSVSAMP DD.
(continued)

DFSVSMxx member of the IMS PROCLIB dataset	DFSVSMxx	DFSVSAMP
Specifying sequential buffering for an online system	Yes	No
Defining serviceability and trace options	Yes	Yes
Defining DL/I call image trace	Yes	Yes
Defining DASD logging initialization parameters*	No	No
Defining IMS batch without dynamic allocation	No	Yes
Disabling the re-opening of databases after an IMS restart	Yes	No
Defining coupling facility structure names for sysplex data sharing	Yes	Yes
Using the coupling facility for OSAM data caching	Yes	Yes
Enabling the long busy handling function	Yes	No
Enabling the IRLM lock timeout function	Yes	Yes
Preventing transactions from being terminated when HALDB partitions are unavailable	Yes	No
Preventing DBRC calls for HALDB version verification	Yes	Yes

Table 80. DFSVSMxx parameters for Online IMS that can be specified in IMS batch jobs via DFSVSAMP DD. (continued)

DFSVSMxx member of the IMS PROCLIB dataset	DFSVSMxx	DFSVSAMP
Resuming an online reorganization for HALDBs during IMS warm or emergency restart	Yes	No
Discarding preallocated SDEP control intervals	Yes	No
Preventing a / DBRECOVERY command for a database that has INDOUBT EEQEs	Yes	No
Removing the limit for the number of DFS3314W messages issued	Yes	Yes

*The DASD logging initialization parameters have moved to the LOGGER section of the DFSDFxxx member of the IMS PROCLIB data set.

Related concepts

[“VSAM subpool definition” on page 207](#)

VSAM subpools are defined using the VSRBF control statement, one of the control statements in the DFSVSMxx member of the IMS PROCLIB data set.

[“OSAM subpool definition” on page 208](#)

OSAM subpools are defined using the IOBF and DBD statements. Specify the required subpools in the DFSVSAMP data set for batch environments, or in the DFSVSMxx member of the IMS PROCLIB data set for DB/DC environments. When using OSAM to access VSAM Linear data sets (LDS), the data is stored in the OSAM buffer pool. Supply enough OSAM buffer pool definitions (IOBF) to hold these data sets.

[“Specifying VSAM and OSAM subpools” on page 209](#)

Use control statements in the DFSVSAMP data set or the DFSVSMxx member of the IMS PROCLIB data set to specify VSAM and OSAM subpools.

Related reference

[“OSAMxxx section of the DFSDFxxx member” on page 801](#)

The OSAMxxx section of the DFSDFxxx member specifies definitions used to dynamically add, update, or delete OSAM subpools. The section must begin with the header <SECTION=OSAMxxx>. The OSAMxxx section is valid in DB/DC, DBCTL, and batch environments.

[“VSAMxxx section of the DFSDFxxx member” on page 810](#)

The VSAMxxx section of the DFSDFxxx member specifies definitions used to dynamically add, update, or delete VSAM subpools. The section must begin with the header <SECTION=VSAMxxx>. The VSAMxxx section is valid in DB/DC, DBCTL, and batch environments.

Defining Fast Path DEDB buffer pools for single-area structures

This section describes control statements in the DFSVSMxx member that you use to define Fast Path DEDB buffer pools for single-area structures.

Control statements for defining Fast Path DEDB buffer pools for single-area structures

The format of the control statements for defining a Fast Path buffer pool for a single-area structure is:

►► DEDB= ►

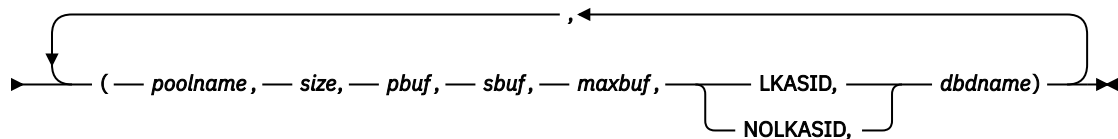

Parameter descriptions for defining Fast Path DEDB buffer pools for single-area structures

DEDB=

Is the required keyword for defining Fast Path buffer pools. It must be in the first position of the control statement.

poolname

The one- to eight-character name for the pool. The poolname is used as identification on display terminals and reports.

size

A three- to five-digit number specifying the size of the pool. All the standard DEDB supported buffer sizes are supported. You can express sizes numerically, or as standard CI sizes, 1K, 2K, 4K.

pbuf

The primary buffer allocation. Specify a value from 1 to 32766.

sbuf

The secondary buffer allocation. Specify a value from 1 to 9999. This secondary allocation is used when the primary allocation runs low.

maxbuf

The maximum number of buffers allowed for this pool. It is a combination of PBUF plus some iteration of SBUF. The maximum value allowed is 32767. If maxbuf is specified greater than 32767, it defaults to 32767.

LKASID | NOLKASID

Specifies whether buffer lookaside is to be performed on read requests for this area.

For VSO DEDB areas that use a single-area structure, this parameter is required. The value that is specified by using the **INIT . DBDS** or **CHANGE . DBDS** DBRC command is the default value. The value that is defined in the RECON data set for the area by using one of the DBRC commands takes precedence over the value defined in the DFSVSMxx PROCLIB member.

dbdname

Associates a pool to a specific area or DBD. If dbdname is an area name, then the pool is used only by that area. If dbdname is a DBD name, then the pool is used by all the areas within that DBD.

Defining Fast Path DEDB buffer pools for multi-area structures

You can enable all DEDB areas that share a single coupling facility structure to use the same buffer pool. This section describes control statements in the DFSVSMxx member that you use to define Fast Path DEDB buffer pools for multi-area structures.

Control statements for defining Fast Path DEDB buffer pools for multi-area structures

The format of the control statements for defining a Fast Path buffer pool for a multi-area structure is:

►► DEDBMAS= ►

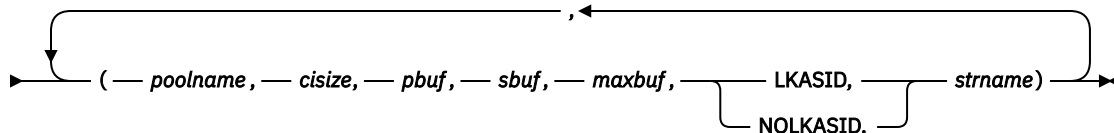

Parameter descriptions for defining Fast Path DEDB buffer pools for multi-area structures

DEDBMAS=

Defines a Fast Path buffer pool that is to be used by a multi-area structure.

poolname

The 1- to 8-character name for the pool. The *poolname* is used as identification on display terminals and reports.

cisize

The control interval size of the area. All areas that share a multi-area structure must have the same control interval size. If there is a discrepancy between the control interval size of the area used in creating the structure and the control interval size of the area attempting to share the structure, the open process for the area attempting to share the structure fails.

pbuf

The primary buffer allocation. Specify a value from 1 to 32,766.

sbuf

The secondary buffer allocation. Specify a value from 1 to 9999. This secondary allocation is used when the primary allocation runs low.

maxbuf

The maximum number of buffers allowed for this pool. It is a combination of PBUF plus some iteration of SBUF. The maximum value allowed is 32,767. If *maxbuf* is specified greater than 32,767, it defaults to 32,767.

LKASID | NOLKASID

Indicates whether this pool is used as a local cache with buffer lookaside capability.

For VSO DEDB areas that use a multi-area structure, whether buffer lookaside is performed must be specified by using the DFSVSMxx PROCLIB member. Specifications using the DBRC batch command **INIT . DBDS** or **CHANGE . DBDS** are ignored.

strname

The required 1- to 16-character name of the primary coupling facility structure.

The installation must have defined the structure in the coupling facility resource management (CFRM) administrative policy. The structure name must follow the naming rules of the CFRM. If the name has fewer than 16 characters, the system pads the name with blanks. The valid characters are A-Z, 0-9, and the following special characters:

\$ @ # _

Names must be uppercase and start with an alphabetic character.

Restriction: Avoid using names that IBM uses for its structures. Do not begin structure names with the letters A-I, or the character string SYS.

Related reading: For more information about shared VSO and multi-area structures, refer to *IMS Version 15.4 Database Administration*.

Defining VSAM buffer pools

This section describes control statements in the DFSVSMxx member that you use to define multiple VSAM local shared resource pools.

Related reading: For overview information, refer to “IMS buffer pools” on page 206.

One or more VSAM local shared resource pools can be defined through the subpool definition statement POOLID. One POOLID statement is specified for each shared resource pool. The POOLID statement must be followed by one or more VSRBF subpool definition statements, which define the subpools within that shared pool.

POOLID control statements

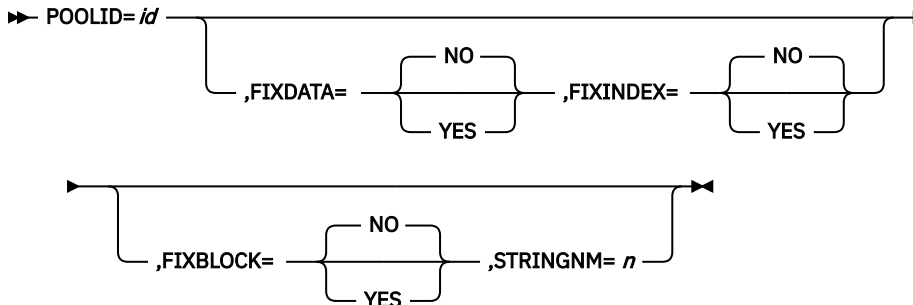

The buffer fix and string number parameters must be separated by commas and coded without intervening blanks. They can be coded in any order. If any parameter is invalid, the remainder of the statement is ignored and defaults apply for the remaining parameters.

The POOLID buffer fix and string number values override the VSAMFIX and STRINGMX parameters on the OPTIONS statement for that particular shared pool.

POOLID=

Required keyword for VSAM shared resource pool definition. It must begin in the first position of the control statement. Only one set of subparameters can be entered for each control statement. Each statement defines one shared resource pool. The POOLID statement is used with the DBD statement to direct a given data set to a specific shared resource pool.

Only the first VSAM local shared resource pool defined with the POOLID statement can contain VSAM subpool definition statements (VSRBF) for subpools not dedicated to specific data sets. All VSAM local shared resource pools defined after the first pool must be dedicated to specific data sets. Add a DBD statement that defines which data sets use the shared resource pool. Therefore, defining a VSAM local shared resource pool other than the first pool defined, without a DBD statement referencing that pool, results in a failure for the POOLID statement.

POOLIDs 0 and 1-254 can be used. The total number of POOLIDs must not exceed 255. Also see the paragraph under *RESVPOOL=*.

id

A one- to four-character alphanumeric field that specifies a user identifier assigned to a shared resource pool. This parameter is required. It is used with the DBD statement to direct a given data set to a specific shared pool.

FIXDATA=YES | NO

Specifies the data shared resource pool long-term-page-fixing option. If YES is specified, all buffers in the data shared resource pool are long-term-page-fixed at initialization of the shared resource pool. If NO is specified, no buffers in the data shared resource pool are long-term-page-fixed. If this parameter is omitted, the default is NO.

FIXINDEX=YES | NO

Specifies the index shared resource pool long-term-page-fixing option. If YES is specified, all buffers in the index shared resource pool are long-term-page-fixed at initialization of the shared resource pool. If NO is specified, no buffers in the index shared resource pool are long-term-page-fixed. If this parameter is omitted, the default is NO.

FIXBLOCK=YES | NO

Specifies the I/O-related control blocks long-term-page-fixing option. If YES is specified, all I/O-related control blocks are long-term-page-fixed at initialization of the shared resource pool. If NO is specified, no I/O-related control blocks are long-term-page-fixed. If this parameter is omitted, the default is NO.

STRINGNM=n

Specifies the maximum number of VSAM I/O requests that can be concurrently active. It can be used to override the MAXREGN parameter specified at system definition time and the PST value on the EXEC statement. The specified value must be a decimal number 1 - 255. The default is 255. Specify a number as close as possible to the maximum number of regions expected to be running concurrently, including those regions that can be dynamically started. If the value is omitted or invalid, the default is the MAXREGN value or the PST value, which, if present, overrides the MAXREGN value.

RESVPOOL control statements**RESVPOOL=shared-pool-number**

The *shared-pool-number* variable represents the VSAM local shared resource pool number of the shared pool that IMS cannot use. One or more numbers 1 - 254 can be specified in any order and must be separated by commas, but without any blanks. Shared resource pool 0 is reserved for IMS and you cannot use it. A blank must follow the last number specified, and the remaining portion of the statement is not examined.

The RESVPOOL statement is only applicable if you have a product other than IMS using VSAM local shared resource pools that IMS cannot use.

Defining VSAM subpools

This section describes control statements in the DFSVSMxx member that you use to define VSAM subpools.

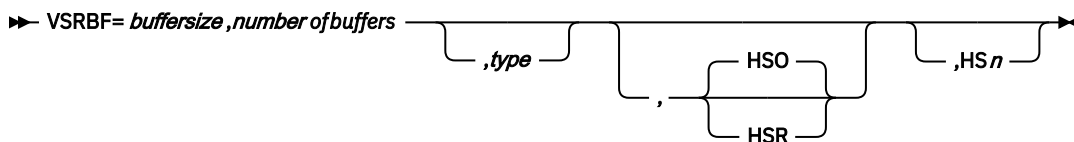
VSRBF control statements**VSRBF=**

The keyword for VSAM subpool definition. It must begin in the first position of the control statement. Only one set of subparameters can appear on each control statement. Each statement defines one subpool.

buffersize

A three- to five-digit number specifying the buffer size for this subpool. Acceptable values are 512, 1024, 2048, 4096, 8192, 12288, 16384, 20480, 24576, 28672, and 32768.

number-of-buffers

A one- to five-digit number (3 to 32767) specifying the number of buffers in this subpool. If you specify a number of buffers less than the minimum number required, IMS increases the number to the minimum and issues a warning message.

type

A one-character field that specifies whether the subpool in the shared resource pool is an index subpool (I) or a data subpool (D). This parameter is optional. If this parameter is invalid or not specified, data subpool (D) is assumed.

If you do not specify a value for type in any VSRBF statements, both data and index occupy the same buffer subpool. When you do specify D or I in any VSRBF statement, you must also specify a type of I for each size that might be required to handle index buffering requests. An error with the message DFS0730I RC 0, DC might result if a subpool of sufficient size is not found.

The following example provides 20 2K buffers and 40 4K buffers that can all be used by both data and index if these are the only VSRBF statements in DFSVSMxx.

```
VSRBF=2048,20
VSRBF=4096,40
```

In the next example, ten index buffers (2K) are provided in the first line, and ten data buffers (2K) are provided in the second line. The third line provides 20 data buffers (4K). No index buffers of 4K are provided in this example.

```
VSRBF=2048,10,I
VSRBF=2048,10,D
VSRBF=4096,20
```

Although the index and data components of a VSAM data set must reside in the same shared resource pool, they can be assigned different subpools. You can define subpools that accommodate each component of the data set. Note that an index subpool cannot exist without a data subpool (within a given shared resource pool), but a data subpool can exist without an index subpool. If any index subpool exists in a local shared resource pool, all index components of VSAM data sets in that shared pool must share the index subpool. The CONTROLINTERVALSIZE parameter in the listing of the VSAM catalog that shows the control interval sizes assigned to the components can help you determine the buffer sizes needed for both index and data components.

HSO | HSR

Optionally specifies the kind of action IMS should take if Hiperspace (extended storage on z/OS) buffering for this subpool is not available. If this parameter is invalid or not coded when HSn is given, the HSO option is assumed.

HSO

Indicates that Hiperspace buffering is optional and IMS can continue initialization without Hiperspace buffering.

HSR

Indicates that Hiperspace buffering is required and IMS must terminate if Hiperspace buffering is not available.

HSO and HSR are the minimum truncations of which up to the full terms (HSOptional and HSRequired) are recognized.

HSn

Is an optional one- to eight- digit number *n* ranging from (3 to 16777215) that specifies the number of Hiperspace buffers to build for this subpool.

HSO | HSR and HSn are valid only on 4K and larger boundaries. See the following example.



```
VSRBF=4096,10,HS40,HSR
VSRBF=8192,10,HS50,HSRE
VSRBF=12288,4,HS12
VSRBF=16384,4,HS20,HSO
VSRBF=20480,4,HSOP,HS8
VSRBF=24576,4,HSOPTIONAL,HS8
VSRBF=28672,1,HS9,HSREQUIRED
VSRBF=32768,1,HSREQ,HS9
```

Only the buffer size and number-of-buffers parameters are positional. The type and HS parameters can be coded in any order but must be separated by commas without any intervening blanks. If any parameter is invalid, the remainder of the statement is ignored and defaults apply for the remaining parameters.

Using the VSRBF statement without any POOLID statement can still define one, and only one, VSAM local shared resource pool. However, even with one VSAM shared resource pool, you can now use the TYPE parameter to define either an index or data subpool within the shared resource pool.

Restriction: The total Hiperspace buffer pool allocation is limited to 2 GB. If the number of buffers times the buffer size exceeds the limit, a 2 GB pool size is used and a warning message is issued.

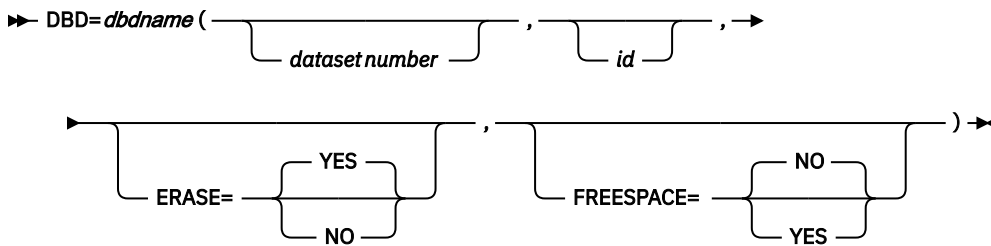
DBD control statement



DBD=

If coded, specifies that the data set having a matching ID parameter, as defined on the POOLID shared pool definition statement, is to be directed to the indicated shared resource pool.

A shared resource pool is assigned to a data set based upon the shared resource pool identifier specified on the DBD statement for that data set. Then a subpool within the assigned shared resource pool is assigned to the data set based upon buffer length.

If no subpool in the shared resource pool is big enough, an attempt to open the data set fails. An open is then retried in the default shared pool, which is the first shared resource pool you define. To avoid another open failure, subpools of the largest sizes that might be encountered in the system should be defined in the default pool.

If no DBD statement is coded for a data set, the default shared resource pool is assigned.

dbdname

Specifies the name on the DBD macro statement NAME= keyword. The DBD name can be for a non-partitioned database, a HALDB partition, or a HALDB master. For a HALDB partition, specify the name of the partition as the dbdname. If you specify a HALDB master name, all the HALDB partitions associated with the HALDB are assigned to the same shared resource pool.

Related reading: See [Database Description \(DBD\) Generation utility \(System Utilities\)](#) in *IMS Version 15.4 System Utilities* for information about coding the DBD macro statement.

data set number

Identifies the specific data set of a data set group within a database (identified by the dbdname parameter) that requests assignment of a specific shared pool. The number is an IMS internally assigned value between 1 and 10.

For data organizations such as primary index, unique secondary index, and HISAM without dependent segments, the primary data set of the data set group is assigned data set number 1. No secondary data set of the data set group exists for these data organizations.

For data organizations such as non-unique secondary index and HISAM with dependent segments, the primary data set of the data set group is assigned data set number 1, and the secondary data set of the data set group is assigned data set number 2.

For hierarchic direct data organization, the data set group always consists of a single data set. The data set of the first data set group is assigned data set number 1, and data set numbers for subsequent data set groups are sequentially assigned numbers 2,3,...10. The maximum number of data set groups for a database is 10.

Requirement: For High Availability Large Databases (HALDBs), specify the data set number as an alphabetic character. The valid data set numbers defined for HALDB partition data sets are A through J, L, and X. (When HALDB Online Reorganization is used, data sets M through V and Y are automatically directed to the same shared resource pools for data sets A through J and X. The specification of M through V and Y are not valid.) The data set of the first data set group must be assigned the letter A (for both data sets A and M when HALDB Online Reorganization is used). The data set numbers for subsequent data set groups (B through J and N through V when HALDB Online Reorganization is used) must be sequentially assigned the other valid letters (B,C, ..., J). Use the letter L to specify the indirect list data set. For PHIDAM databases, use the letter X (for both data sets X and Y when HALDB Online Reorganization is used) to specify the primary index data set.

For PSINDEX databases, you cannot code an alphanumeric to designate the data set number. You must code a numeric value.

id

Specifies the user-defined identifier that is assigned to a specific shared resource pool. The ID is a one- to four-character alphanumeric field and must be equal to the ID assigned to the specific shared resource pool on the POOLID statement.

ERASE=YES | NO

Indicates the treatment of logical records that are deleted. YES indicates that the deleted record should be erased. NO indicates that the deleted record should not be erased but should be marked as a deleted record. The default is YES.

FREESPACE=YES | NO

Indicates the treatment of the defined free space percent in the KSDS. If YES is specified, the defined free space should be preserved. If NO is specified, the defined free space should not be preserved. The default is NO.

Defining VSAM performance options

This section describes the OPTIONS control statement parameters in the DFSVSMxx member that can be used to influence the performance of the IMS DL/I buffering services.

The word OPTIONS starting in position one identifies the OPTIONS statement. You can specify the parameters in any order, but you must separate them with commas. A blank must follow the last parameter. The remaining portion of the statement is not examined. You cannot continue an OPTIONS statement on a subsequent line, but you can provide several statements. If an OPTIONS parameter appears more than once, its setting is determined by the last occurrence. The OPTIONS statement and all its parameters are optional.

Control statements

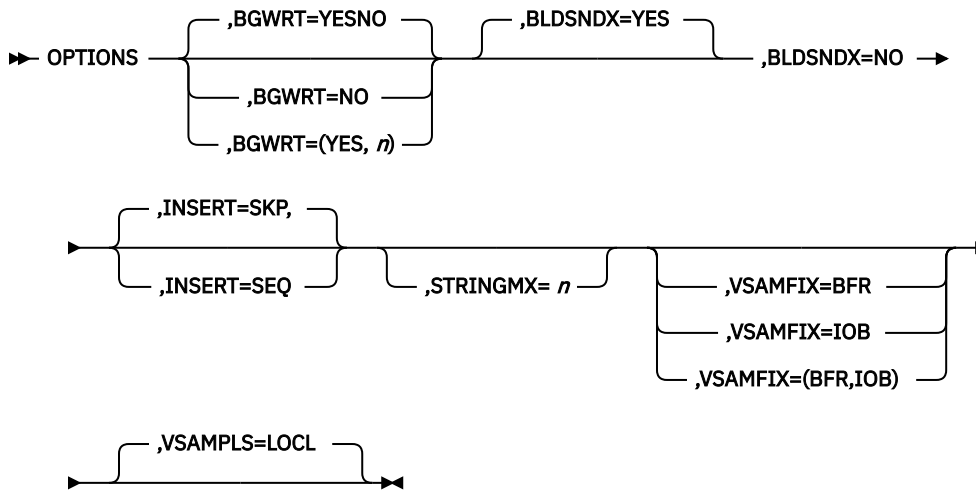

BGWRT=

Specifies whether (YES) or not (NO) the background write (BGWRT) function of the buffer handler is to be active. You can also activate background write by coding BGWRT=(YES,*n*) or omitting the parameter. *n*: is a two-digit number from 10 to 99 specifying the percentage of buffers in each subpool to be considered as candidates for writing by the background write function; the default is 34.

Related reading: For an explanation of background write, see *IMS Version 15.4 Database Administration*.

BLDSNDX=

Provides an option to control the building of secondary indexes during initial load of an HALDB.

If BLDSNDX=YES, or the parameter is omitted, then the creation of secondary indexes during initial load is allowed.

If BLDSNDX=NO, then the creation of secondary indexes during initial load is suppressed.

INSERT=

Specifies the insert mode that the buffer handler uses when inserting new KSDS logical records into any of the following databases: HISAM, Single segment HISAM, and INDEX.

If a program inserts many new root segments in sequence by key, specifying INSERT=SEQ causes the buffer handler to use VSAM sequential mode PUTs. VSAM leaves free space (if you specify it in the DEFINE) for VSAM data sets in CIs created for the new records that are inserted using VSAM's mass insert. Specifying INSERT=SKP, or omitting the parameter, causes the buffer handler to use VSAM skip sequential mode PUTs if the database is in sequential mode, or to use direct mode PUTs if the database is not in sequential mode. For more information about sequential mode databases, see “VSAM subpool definition” on page 207. In either mode, VSAM does not leave free space, even if it is specified in the DEFINE regardless of whether DL/I inserts in load or insert mode.

The default is SKP, except in utilities, where it is SEQ.

You can override INSERT=SEQ with the FREESPACE parameter of the DBD control statement. FREESPACE=YES causes the buffer handler to use VSAM sequential mode PUTs. Specifying FREESPACE=NO, or omitting the parameter, causes the buffer handler to use VSAM skip sequential mode PUTs if the database is in sequential mode, or to use direct mode PUTs if the database is not in sequential mode.

STRINGMX=

Specifies the maximum number of VSAM requests that can be concurrently active. *n* is any number between 1 and 255. If you omit this keyword, the default value is the value specified on either the MAXREGN= parameter on the IMSCTRL macro or the PST= parameter on the IMS procedure EXEC statement (which overrides the MAXREGN= value). The STRINGMX= keyword overrides either of these two values.

VSAMFIX=

Causes VSAM resource pools to be page fixed in main storage.

BFR

Specifies that the buffer subpools and control blocks should be fixed. If you define a large number of buffers and then use VSAMFIX=BFR the system might abend.

IOB

Specifies that the input/output related blocks should be fixed.

Either or both operands can be specified. The syntax for specifying both operands is (BFR,IOB) or (IOB,BFR).

VSAMPLS=LOCL

Specifies that the VSAM shared resource pools are to be built. The only valid value is the default, LOCL.

Defining OSAM subpools

This section describes control statements in the DFSVSMxx member that you use to define OSAM subpools.

IOBF control statements

►► IOBF=(A) ◄◄

A

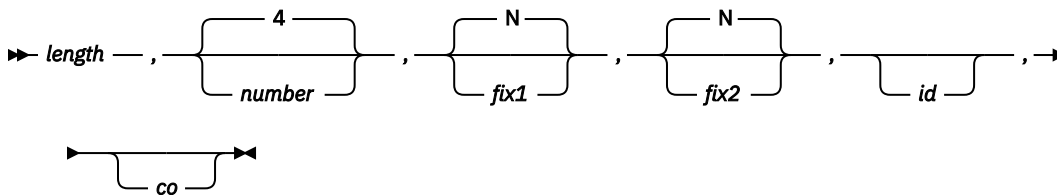

IOBF=

Is the required keyword for OSAM subpool definition. It must begin in the first position of the control statement. Only one set of subparameters can appear on each control statement.

length

Specifies the length of the buffers in the subpool. Specify the value in bytes, between 512 and 32000. Depending on the value that you specify, IMS rounds it up to 512, 1024, 2048, and thereafter to multiples of 2048. You can code specifications of 1024 and above as 1K, 2K, 4K, and thereafter round them up to multiples of 2K to a maximum of 32K. If you enter an invalid value, IMS ignores the entire IOBF statement. This parameter is required.

number

Specifies the number of buffers in the subpool. If specified, you must choose a value between 4 and 32767. If you choose a number greater than 32767, the default value of 255 is used. If not specified, the default value is 4. If this parameter is invalid, the remainder of the entry is ignored, and defaults apply for all remaining parameters. This parameter is optional.

fix1

Specifies the buffer long-term page-fixing option. If you specify Y, all buffers and buffer prefixes associated with this subpool are long-term page-fixed at initialization of the subpool. If you specify N, no buffers associated with this subpool are long-term page-fixed at initialization of the subpool. The default is N. This parameter is optional.

fix2

Specifies the buffer prefix long-term-page-fixing option. If you specify Y, all buffer prefixes associated with this subpool and the subpool header are long-term-page-fixed at initialization

of the subpool. If you specify N, the subpool header and all buffer prefixes associated with this subpool are not long-term-page-fixed at initialization of the subpool. The default is N. This parameter is optional.

id

Specifies a user-defined identifier to be assigned to a subpool. This ID is a one- to four-character alphanumeric field and is used with the DBD statement to assign a specific subpool to a given data set. If this parameter is not coded, IMS assigns a null ID to the subpool.

If two or more subpool definition statements specify the same buffer size (without the subpool ID), the number of buffers from the statements are summed. If the total does not exceed 32767, IMS builds a single subpool with the total number of buffers; however, if it does exceed 32767, a single subpool with 255 buffers is built. If two or more subpool definition statements specify the same buffer size, the statement with lower alphanumeric order is considered as default. The lowest possible value is null ID.

co

Specifies the subpool caching option. For more information about OSAM data caching, see [“OSAM subpool definition”](#) on page 208.

You can specify the caching option in one of the following ways:

omitted

No data caching.

Caching is not active for the subpool.

N

No data caching.

Caching is not active for the subpool.

A

Cache all data.

Write all data read from DASD and all changed data to the coupling facility

C

Cache only changed data.

Write all changed data written to DASD to the coupling facility.

If you specify any value other than A, C, or N, no data caching for the subpool occurs. The default is N.

Requirement: Ensure that all IMS data sharing subsystems, whether Batch or Online, use the same structure and Caching Options (CO) when using OSAM DL/I Data Caching (ODC). These options are defined in either the DFSVSMxx PROCLIB members for Online, or in the DFSVSAMP DD cards for Batch with the CFNAMES and IOBF statements. Failure to ensure structure consistency across IMS subsystems can result in data integrity or performance problems.

DBD control statements

Diagram illustrating the DBD control statement syntax: `DBD=dbdname (data setnumber ,id)`. The text is enclosed in a box with arrows pointing to the left and right, indicating its position within a larger statement.

DBD=

If coded, specifies that the indicated subpool is to be assigned to the data set having a matching ID parameter as defined on the IOBF= subpool definition statement. For OSAM, ERASE and FREESPACE are invalid.

dbdname

Specifies the name on the DBD macro statement NAME= keyword. The DBD name can be for a non-partitioned database, a HALDB partition, or a HALDB master. For a HALDB partition, specify

the name of the partition as the dbdname. If you specify a HALDB master name, all the HALDB partitions associated with the HALDB are assigned to the same subpool.

Related reading: For information about coding the DBD macro statement, see [Database Description \(DBD\) Generation utility \(System Utilities\)](#).

data set number

Identifies the specific data set of a data set group within a database (identified by the dbdname parameter) that requests assignment of a specific shared pool. The number is an IMS internally assigned value between 1 and 10.

For data organizations such as primary index, unique secondary index, and HISAM without dependent segments, the primary data set of the data set group is assigned data set number 1. No secondary data set of the data set group exists for these data organizations.

For data organizations such as non-unique secondary index, and HISAM with dependent segments, the primary data set of the data set group is assigned data set number 1, and the secondary data set of the data set group is assigned data set number 2.

For hierarchic direct data organization, the data set group always consists of a single data set. The data set of the first data set group is assigned data set number 1, and data set numbers for subsequent data set groups are sequentially assigned numbers 2,3, ...10. The maximum number of data set groups for a database is 10.

Requirement: For High Availability Large Databases (HALDBs), specify the data set number as an alphabetic character. The valid data set numbers defined for HALDB partition data sets are A through J, L, and X. (When HALDB Online Reorganization is used, data sets M through V and Y are automatically directed to the same shared resource pools for data sets A through J and X. The specification of M through V and Y are not valid.) The data set of the first data set group must be assigned the letter A (for both data sets A and M when HALDB Online Reorganization is used). The data set numbers for subsequent data set groups (B through J and N through V when HALDB Online Reorganization is used) must be sequentially assigned the other valid letters (B,C, ..., J). Use the letter L to specify the indirect list data set. For PHIDAM databases, use the letter X (for both data sets X and Y when HALDB Online Reorganization is used) to specify the primary index data set.

id

Specifies the user-defined identifier to be assigned to a specific subpool. The ID is a one- to four-character alphanumeric field and must be equal to the ID assigned to the specific subpool on the IOBF statement.

Subpools are assigned to data sets based upon buffer length. First, a subpool having buffers equal to or greater than the buffer length required for the data set is located. Then, if a specific subpool was requested, it is assigned, if its length is not less than the required length. In this case, the first subpool that meets the length criterion is assigned. The subpool might not have an ID assigned to it.

OSAMOP control statements

➤ OSAMOP — IOSCB=NO ➤

The OSAMOP statement allows options specific to the OSAM access method.

IOSCB=NO

Indicates that no OSAM resources are to be allocated to the batch applications that do not require OSAM services.

➤ OSAMOP — OSAMGTF=YES ➤

OSAMGTF=YES

Enables OSAM to generate GTF trace records while in batch.

Requesting that z/OS dynamic allocation use extended storage

IMS uses z/OS dynamic allocation extensively to provide access to full-function and Fast Path databases.

The blocks that z/OS provides (DSABs and TIOTs) are put into low private storage, unless otherwise requested. Use the DBALLABOVE statement to change the default and put them into extended private storage. This parameter is applicable only for IMS DLIBATCH regions when it is specified in DFSVSAMP DD statements. It is ignored when it is specified in DFSVSMxx members that are used for online IMS regions.

►► DBALLABOVE ◄◄

DBALLABOVE

This statement changes the location of the DSAB and TIOT blocks that z/OS builds and dynamically allocates for IMS database data sets from low private storage to extended private storage.

Specifying sequential buffering for an online system

Use the SBONLINE control statement in the DFSVSMxx member to request sequential buffering for an IMS or IBM CICS Transaction Server for z/OS system.

This statement applies to the IMS DB/DC or DBCTL environments. SBONLINE requests loading of SB modules and specifies the maximum amount of buffer space that SB can use.

The format of the SBONLINE control statement is as follows:

Control statements

►► SBONLINE _____ ◄◄
 └─ ,MAXSB= nnnn ─┘

Parameter descriptions

SBONLINE =

Specifies that sequential buffering modules are to be loaded in the IMS DB/DC or DBCTL environments, thereby allowing subsequent use of sequential buffering.

By default, IMS does not load the SB modules. This prevents an increase in virtual storage requirements.

MAXSB=nnnn

Specifies the maximum amount of space (in kilobytes) that can be allocated to SB buffers. This number represents the total amount of space to be allocated for **all** concurrently executing programs, not for just one individual program. Setting a limit on the amount of SB space protects you from allocating excessive virtual storage. The default for MAXSB is unlimited space.

When the MAXSB limit is reached, IMS stops allocating SB buffers until terminating programs release buffer storage.

Defining serviceability and trace options

This section describes the OPTIONS control statement parameters in the DFSVSMxx member, which can be used to influence the serviceability of IMS.

For example, the OPTIONS statement allows you to specify which IMS traces should be activated automatically by the system during IMS initialization.

The word OPTIONS starting in position 1 identifies the OPTIONS statement. You can specify the parameters in any order, but you must separate them with commas. A blank must follow the last

parameter. The remaining portion of the statement is not examined. You cannot continue an OPTIONS statement on a subsequent statement, but you can provide several statements. If an OPTIONS parameter appears more than once, its setting is determined by the last occurrence. The OPTIONS statement and all its parameters are optional.

Recommendation:

Select ON for the following parameters:

- DL/I=
- LOCK=

For an online system, select ON for these additional parameters:

- DISP=
- SCHD=

Activating the trace tables specified by these parameters does not cause a noticeable performance impact and each of the trace tables can be helpful to you in diagnosing various problems that might occur in your environment. For certain types of problems, the IMS Support Center needs the trace output. If the trace output is not available, you might need to re-create the problem, which takes time and delays the resolution of the problem.

If you specify OUTMED for DL/I and lock traces, IMS replaces this with a specification of OUTHIGH. If turning on external tracing for DL/I and lock, you should use the highest level of tracing.

Related reading: For more information about all these traces, see *IMS Version 15.4 Diagnosis*.

Valid environments

The following table lists serviceability and trace options that can be activated for particular environments. If you attempt to activate a trace in an environment that does not support that type of trace, IMS ignores your request.

Environment	Valid serviceability and trace options
Batch	<ul style="list-style-type: none"> • DIAG= • DL/I= • DLOG= • DUMP= • DUMPIO= • ISSUE681= • ISSUE840= • LOCK= • SECT=
DB/DC	All trace types, except for LRTT=, are valid in a DB/DC environment.
DBCTL	<ul style="list-style-type: none"> • CSLT • DIAG= • DISP= • DL/I= • DLOG= • DUMP= • DUMPIO= • FPTT= • ISSUE681= • ISSUE840= • LATC= • LOCK= • OCMD • ORTT= • QMGR= • SCHD= • SECT= • SQT= • STRG= • SUBS=

Environment	Valid serviceability and trace options
DCCTL	<ul style="list-style-type: none"> • DIAG= • DISP= • DL/I= • DLOG= • DUMP= • DUMPIO= • FAST= • FPTT= • IDCO= • LATC= • LUMI • MSCT= • OTMT= • QMGR= • RRS= • SECT= • SCHD= • SQTT= • STRG= • SUBS=

Control statements

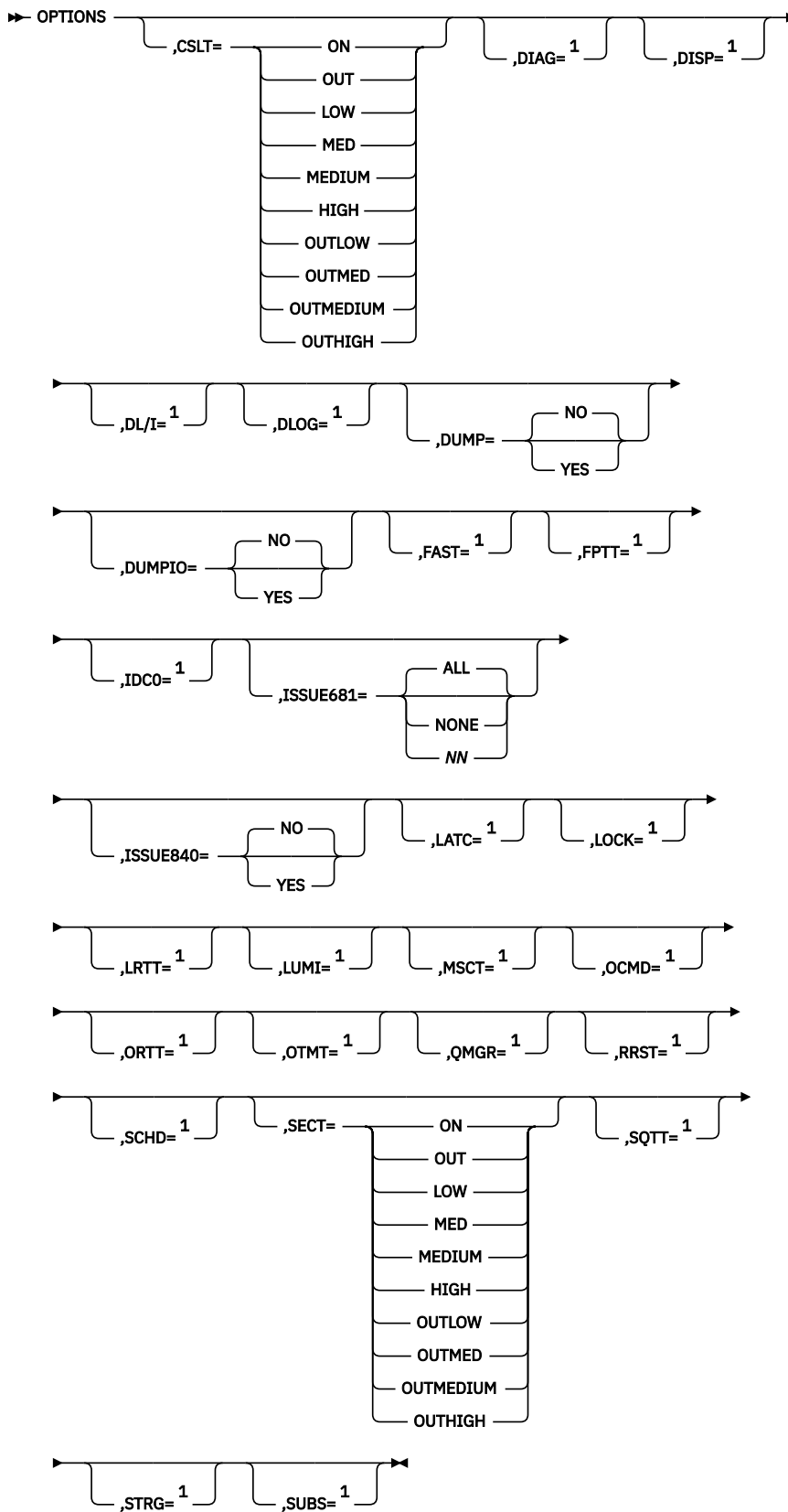

Notes:

¹ This parameter accepts values from the common options listed below.

Common options

ON

Turns on the trace table.

OUT

Initializes and turns on the trace table for output to the log. Log records 4096 bytes long are written to the log when trace records are written.

LOW

Turns on the trace for all low volume events.

MED

Turns on the trace for all low and medium volume events.

MEDIUM

Turns on the trace for all low and medium volume events.

HIGH

Turns on the trace for all low, medium, and high volume events.

OUTLOW

Initializes the trace table for output to the log and turns it on for tracing all low volume events.

OUTMED

Initializes the trace table for output to the log and turns it on for tracing all low and medium volume events.

OUTMEDIUM

Initializes the trace table for output to the log and turns it on for tracing all low and medium volume events.

OUTHIGH

Initializes the trace table for output to the log and turns it on for tracing all low, medium, and high volume events.

Related Reading: See *IMS Version 15.4 Diagnosis* for information about when and why trace tables are used, and defining and setting up trace facilities.

Parameter descriptions**CSLT=**

Activates an IMS trace that traces activity related to IMS's interaction with the Common Service Layer. This includes IMS's interaction with OM, RM, and SCI. No default value exists. If this parameter is omitted, the trace is not activated by the OPTIONS statement. It can be activated and deactivated by the online /TRACE command.

DIAG=

Activates the /DIAGNOSE command trace tables. If this parameter is omitted, the trace is not activated by the OPTIONS statement. It can be activated and deactivated by the online /TRACE command.

Related reading: For more details on the /DIAGNOSE and /TRACE commands, see *IMS Version 15.4 Commands, Volume 1: IMS Commands A-M*.

DISP=

Activates an IMS trace and traces the calls of the IMS dispatcher. No default value exists. If this parameter is omitted, the trace table is not activated by the OPTIONS statement. It can be activated and deactivated by using the online /TRACE command.

Restriction: DISP= is applicable to the online system only. The DISP trace is not allowed in a batch environment. If this trace is requested in a batch environment, the request is ignored.

DL/I=

Activates an IMS trace that traces the calls of certain DL/I modules and the functions invoked by these DL/I modules. The default value is ON. The only exception to this is for batch regions. For batch regions, the default is that the DL/I trace is off. To deactivate the DL/I trace table, issue the /TRACE command in an online environment.

The DL/I trace, the program isolation trace, and the lock trace share the same trace table.

This keyword can also be used to turn on the DL/I retrieve trace table, but it does not control the number of table entries, which is fixed at 255.

If you specify OUTMED for DL/I and lock traces, IMS replaces this with a specification of OUTHIGH. If turning on external tracing for DL/I and lock, you should use the highest level of tracing.

DLOG=

Activates an IMS trace. The DASD log trace traces the activity of the IMS DASD logger. No default value exists. If this parameter is omitted, the trace table is not activated by the OPTIONS statement. It can be activated/deactivated by using the /TRACE command.

DUMP=

Provides a serviceability aid. If you specify NO or omit the parameter and an abnormal condition is encountered, the buffer handler issues a pseudoabend. If you specify YES and an abnormal condition is encountered, the buffer handler issues a standard abend, which results in the control region abnormally terminating also. If DUMP=YES and any abnormal termination occurs, the modified or newly created buffers in the pool at that time are not written to the data set.

For batch environments, if you specify NO or omit the parameter, a dump is taken and all modified buffers in all subpools are written to the data set. This cleans up any outstanding I/Os before purging the pools. If you specify YES, only a dump is taken. The modified buffers are not written to the data set.

DUMPIO=

Provides a serviceability aid for analyzing OSAM I/O errors. If you specify YES and an OSAM I/O error occurs, the IMS region abnormally terminates with a U0764. If the DUMPIO option is requested, the DFS0762I error message is not displayed.

FAST=

Activates an IMS trace that traces DBF trace entries from various Fast Path modules. No default exists. If this parameter is omitted, the trace is not activated by the OPTIONS statement. It can be activated and deactivated by using the online /TRACE command.

Recommendation: Run the FPTRACE in a test environment only. FPTRACE output is very large and can impact performance.

Restriction: The FAST trace is not allowed in a batch environment. If this trace is requested in a batch environment, the request is ignored.

Related reading: For more details on the FPTRACE, see *IMS Version 15.4 Diagnosis*.

FPTT=

Activates a Fast Path trace that traces certain Fast Path modules and the functions invoked by these Fast Path modules. The default value is OFF. To activate the Fast Path trace table, issue the /TRACE command in an online environment.

The Fast Path trace resides in its own trace table.

Related reading: For more details on the Fast Path trace, see *IMS Version 15.4 Diagnosis*.

IDC0=

Activates the tracing of errors in modules DFSCNXA0 and DFSIDC00. No default value exists. If this parameter is omitted, the trace table is not activated by the OPTIONS statement. It can be activated or deactivated by using the online /TRACE command.

Restriction: The IDC0 trace is not allowed in a batch or DBCTL environment. If this trace is requested in either a batch or DBCTL environment, the request is ignored.

ISSUE681=

Specifies the number of DFS681I messages to be issued per second within a batch or BMP region.

ALL

Allows all DFS681I messages generated to be issued. All is the default.

NONE

Allows no DFS681I messages to be issued.

NN

Is the number (1 - 99) of DFS681I messages that you allow to be issued. If some DFS681I messages are not issued, DFS683I is issued and states the number of DFS681I messages omitted.

ISSUE840=

Specifies whether message DFS0840I is issued if there is a duplicate segment in a unique secondary index, even if it is possible to back out prior changes for the call.

NO

Specifies that DFS0840I message is not issued for this condition. NO is the default.

YES

Specifies that DFS0840I message is issued for this condition.

LATC=

Activates an IMS trace. LATCH traces IMS latch activity. No default value exists. If this parameter is omitted, the trace table is not activated by the OPTIONS statement. It can be activated and deactivated by using by the /TRACE command.

Restriction: The LATC trace is not allowed in a batch environment. If this trace is requested in a batch environment, the request is ignored.

LOCK=

Activates an IMS trace that traces the lock activity of certain DL/I modules. The default value is ON. The only exception to this is for batch regions. For batch regions, the default is that the lock trace is off. To deactivate the LOCK trace table, issue the /TRACE command in an online environment.

The lock trace, the program isolation trace, and the DL/I trace share the same trace table.

If you specify OUTMED for DL/I and lock traces, IMS replaces this with a specification of OUTHIGH. If turning on external tracing for DL/I and lock, you should use the highest level of tracing.

Restriction: The LOCK trace is not allowed in a DCCTL environment. If this trace is requested in a DCCTL environment, the request is ignored.

LUMI=

Activates an IMS trace that traces LUM code that supports an LU 6.2 device. It contains the following information:

- Record written on entry and exit to selected LU 6.2 device modules
- Information from APPC/MVS verb with acceptable or unacceptable return code

If this parameter is omitted, the trace table is not activated by the OPTIONS statement. It can be activated and deactivated by using the online /TRACE command.

Restriction: The LUMI trace is not allowed in a batch or DBCTL environment. If this trace is requested in one of these environments, the request is ignored.

MSCT=

Activates an IMS trace for Multiple Systems Coupling (MSC).

OCMD=

Activates an IMS trace that traces IMSplex command activity. No default value exists. If this parameter is omitted, the trace is not activated by the OPTIONS statement. It can be activated and deactivated by the online /TRACE command.

ORTT=

Activates an IMS trace that traces the IMS Database Recovery Facility activity in the IMS control region. If this parameter is omitted, the IMS Database Recovery Facility trace is not activated by the OPTIONS statement. It can be activated and deactivated by using the online /TRACE command.

Restriction: The ORTT trace is not allowed in a batch or DC environment. If this trace is requested in this environment, the request is ignored.

OTMT=

Activates an IMS trace. OTMT traces the flow of control through IMS OTMA. No default exists. If this parameter is omitted, the trace is not activated by the OPTIONS statement. It can be activated and deactivated by using the online /TRACE command.

Restriction: The OTMT trace is not allowed in a batch or DBCTL environment. If this trace is requested in any of these environments, the request is ignored.

QMGR=

Activates an IMS trace for an online system. QMGR traces calls made to the IMS queue manager. No default value exists. If you omit this parameter, the trace table is not activated by the OPTIONS statement. It can be activated and deactivated by using the online /TRACE command.

Restriction: The QMGR trace is not allowed in a batch environment. If this trace is requested in a batch environment, the request is ignored.

RRST=

Activates an IMS trace for z/OS Resource Recovery Services (RRS). No default value exists. If this parameter is omitted, the trace table is not activated by the OPTIONS statement. The trace can be activated and deactivated by using the online /TRACE command.

Restriction: The RRST trace is not allowed in a batch environment. If this trace is requested in a batch environment, the request is ignored.

SCHD=

Activates an IMS trace. SCHD traces the calls of the IMS scheduler. No default value exists. If this parameter is omitted, the trace table is not activated by the OPTIONS statement. It can be activated and deactivated by using the online /TRACE command.

Restriction: The SCHD trace is not allowed in batch environments. If this trace is requested in either of these environments, the request is ignored.

SECT=

Activates the security trace table. If this parameter is omitted, the trace is not activated by the OPTIONS statement. It can be activated and deactivated by using the online /TRACE command.

SQTT=

Activates an IMS trace for an online system. SQTT traces the shared queues interface including:

- Initialization of the connection to CQS
- CQS requests
- Notification of work available from CQS
- Termination of the connection to CQS

No default value exists. If you omit this parameter, the trace table is not activated by the OPTIONS statement, but can be activated and deactivated by using means of the online /TRACE command.

Restriction: The SQTT trace is not allowed in a batch environment. If this trace is requested in a batch environment, the request is ignored.

STRG=

Activates an IMS trace. STRG traces all calls to the IMS storage manager that require modifications to one of the following pools:

AOIP
CESS
CIOP
CMDP
DYNP
EMHB
FPWP
HIOP
LUMC

LUMP
SPAP

If this parameter is omitted, the trace table is not activated by the OPTIONS statement; instead, it can be activated and deactivated by using the online /TRACE command.

STRG= is applicable only to the online system.

Restriction: The STRG trace is not allowed in a batch environment. If this trace is requested in a batch environment, the request is ignored.

SUBS=

Activates an IMS trace. SUBS traces the connection and disconnection of Db2 for z/OS subsystems to the IMS control region. No default value exists. If this parameter is omitted, the trace is not activated by the OPTIONS statement. It can be activated and deactivated by using the online /TRACE command.

Restriction: The SUBS trace is not allowed in batch environments. If this trace is requested in either of these environments, the request is ignored.

Table 81 on page 879 is a summary of the traces that can be activated using the OPTIONS parameter. It shows the number of trace entries and the storage requirements for the various traces.

Table 81. Trace entries and storage requirements

Type	Number of trace tables	Entry size	Entries per table	Storage bytes required
Common Service Layer	8	20 Hex	126	32 KB
/DIAGNOSE command	64	20 Hex	126	256 KB
Dispatcher	10	20 Hex	126	40 KB
DLI/Loc KB	18	20 Hex	126	72 KB
DLog	6	20 Hex	126	24 KB
Fast Path	2	20 Hex	126	8 KB
Intercommunications	18	20 Hex	126	72 KB
Latch	12	20 Hex	126	48 KB
LU 6.2	8	X '20'	126	32 KB
Multiple Systems Coupling	10	X '20'	126	40 KB
OCMD	8	X '20'	126	32 KB
Online Recovery	8	X '20'	126	32 KB
OTMA	8	X '20'	126	32 KB
Queue Manager	8	X '20'	126	32 KB
Scheduler	5	X '20'	252	20 KB
Shared Queues	8	X '20'	126	32 KB
Storage Manager	10	X '20'	126	40 KB
SubSystem	8	X '40'	63	32 KB
z/OS Resource Recovery Services	12	X '20'	126	48 KB

Related reading: For additional information about the traces that you can define using these keywords, see *IMS Version 15.4 System Utilities*.

Defining DL/I call image trace

This section describes control statements in the DFSVSMxx member that you use to specify a DL/I call image trace.

Control statements

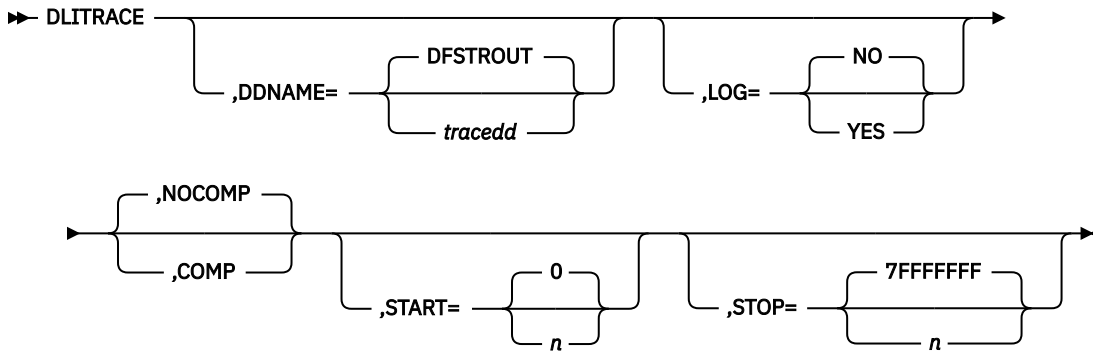

The DLITRACE statement invokes the tracing of DL/I calls in a batch environment. Specify the word DLITRACE in the first position to identify this statement. You can specify the parameters in any sequence, but you must separate them with commas; each parameter can be specified only once. If you do not specify any parameters, IMS uses the default values.

A DLITRACE statement cannot be continued on a subsequent statement. The first statement encountered in the DFSVSAMP data set establishes the options. Subsequent statements are bypassed, and message DFS2471 is issued. In cases where a parameter is repeated, the options remain set as specified by the first occurrence, and message DFS2471 is issued.

Related reading: For details on the use of DL/I trace, see *IMS Version 15.4 Diagnosis*.

Parameter descriptions

DDNAME=

Indicates that sequential data set output is requested and gives the DD statement name (tracedd) to be present in the JCL. If you omit this parameter and do not supply output DD, DDNAME=DFSTROUT is assumed, and an attempt is made to route output to the sequential data set defined by DFSTROUT DD. However, if you omit this parameter and request log output, no attempt is made to open such a sequential data set.

LOG=

Specifies whether (YES) or not (NO) DL/I call image capture output is to be routed to the IMS system log. The default is NO, and a sequential output data set contains the trace output.

NOCOMP | COMP

Specifies whether (COMP) or not (NOCOMP) DL/I Test Program COMPARE statements are generated for both PCB comparisons and data comparisons. The default is NOCOMP.

Related reading: For more information, see *IMS Version 15.4 Application Programming*.

START=

Specifies a one- to eight-character hexadecimal value representing a count of DL/I calls issued by an application program against a specific PSB. This value indicates at which point in the program processing tracing should begin. The default value of 0 begins the tracing at the first DL/I call.

STOP=

Specifies a one- to eight-character hexadecimal value representing a count of DL/I calls. This value indicates the point at which DL/I image capture tracing against a specific PSB should stop. The default value of X'7FFFFFFF' indicates that all the DL/I calls for the batch program are traced.

Defining DASD logging initialization parameters

The DASD logging initialization parameters are moved to the LOGGER section of the DFSDFxxx member of the IMS PROCLIB data set.

For more information, see [“LOGGER section of the DFSDFxxx member” on page 794](#).

Related concepts

[“Allocating log data sets” on page 147](#)

IMS creates logs of activity that are based on online executions. You must allocate sufficient data sets on DASD for the log data associated with your online activity, including online log data sets, system log data sets, and log write-ahead data sets.

[Exit routines \(Exit Routines\)](#)

Related reference

[LOGEDIT: Log edit user exit \(DFSFLGEO and other LOGEDIT exits\) \(Exit Routines\)](#)

Defining IMS batch without dynamic allocation

This section describes control statements in the DFSVSMxx member that you use to disable batch dynamic allocation.

Control statements

➤ NODYNALLOC ➤

Parameter descriptions

NODYNALLOC

Disables batch dynamic allocation. Message DFS2480 appears at initialization time to indicate that batch dynamic allocation is not to occur. This statement disables the default setting, which is batch dynamic allocation enabled.

Disabling the re-opening of databases after an IMS restart

After an IMS warm or emergency restart, IMS re-opens all databases that were open when IMS was brought down. To disable this default behavior, specify the NOPDBO option.

Control statements

➤ NOPDBO ➤

Parameter descriptions

NOPDBO

Disables the automatic re-opening after an IMS warm or emergency restart of databases previously open and authorized. The keyword NOPDBO must start in column 1. If this option is not specified, the databases are reopened.

Defining coupling facility structure names for sysplex data sharing

If you use sysplex data sharing, three coupling facility structure names must be passed to IMS: IRLM, OSAM, and VSAM.

These names are passed to IMS in the CFNAMES control statement in the DFSVSMxx member. The purpose of this statement is to let you select which of the structures, previously defined in the z/OS policy, is to be used at run time.

You can specify one or more CFNAMES control statements. Each statement can contain one or more keyword parameters. Each keyword parameter must be specified in its entirety on a single CFNAMES statement. A specific keyword parameter can not be continued from one CFNAMES statement to another. If keyword parameters are duplicated, the first parameter encountered is used and the others are registered with an error message.

The structure names that you specify in the CFNAMES control statement can be 1 to 16 characters long. All keywords in the statement must be coded, but null values for the CFOSAM and CFVSAM keywords are allowed.

IRLM

If you do not specify structure names in this PROCLIB member or specify only the IRLM structure name, the default is for the environment defaults to use two-way data sharing using the notify protocol.

If the IRLM and OSAM or VSAM structure names do not match the structure names known to the coupling facility at the time of the IDENTIFY, the IDENTIFY is rejected and IMS initialization fails. The first IMS in a data sharing group that identifies itself to the IRLM, sets the data sharing environment for all other IMS subsystems connecting to the same IRLM structure. The first IMS, in other words, sets the structure names for the coupling facility. If, for example, the first IMS does not specify structure names in this PROCLIB member, no other IMS subsystems identifying to this IRLM can specify structure names (except for an IRLM structure name matching the one set by the IRLM); otherwise, the IDENTIFY is rejected and IMS initialization fails. The same thing happens if the first IMS specifies all three structure names and, later, another IMS subsystem tries to identify using one or more different structure names.

OSAM

If you are using OSAM sequential buffering, the OSAM structure registers SB buffers in the coupling facility's cross-system buffer invalidation process.

Control statements

CFNAMES must appear in column 1. No blanks can appear between the keywords.

Syntax

➤ CFNAMES, — CFIRLM= — aaaaaaaaaaaaaaaaaa , — CFVSAM= — bbbbbbbbbbbbbbbb , ➤

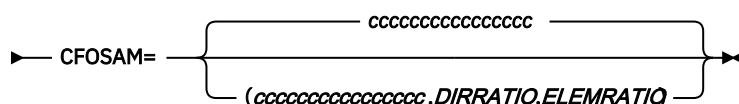

Parameter descriptions

CFNAMES

Specifies the coupling facility structure names that must be passed to IMS.

CFIRLM=aaaaaaaaaaaaaaaa

Specifies the coupling facility lock table structure name for the IRLM.

CFVSAM=bbbbbbbbbbbbbbbb

Specifies the coupling facility XI structure name for VSAM.

CFOSAM=

You can specify either the coupling facility name only, or the coupling facility name and directory-to-element ratios.

cccccccccccccccc

Specifies the coupling facility structure name for OSAM.

(cccccccccccccc,DIRRATIO,ELEMRATIO)

Specifies the coupling facility structure name for OSAM and the directory-to-element ratio that the CF uses to configure the structure for data caching.

The DIRRATIO and ELEMRATIO subparameters are optional. The installation uses the CFRM policy to specify the size of a cached structure. When the structure is allocated, its storage is subdivided to reserve space for directory entries and data elements. The directory-to-element ratio determines the proportion of the cache used for directories and data elements. The ratio is expressed as a pair of whole numbers and is used when a connection is made to the structure. The directory-to-element ratio should reflect the average number of data elements per cache entry. The size of each data element is 2 KB. OSAM data is contained in the coupling facility as multiples of 2 KB data elements. If the ratio is incorrect for an installation's use of the structure, frequent rejections of cache requests can occur because either the cache or the cache structure is full.

The result of dividing the ELEMRATIO value by the DIRRATIO value must not exceed 16, the maximum number of elements supported by an OSAM structure. If the result is greater than 16, the specified ratio is rejected and IMS supplies a ratio.

The DIRRATIO value represents the directory part of the ratio and ELEMRATIO represents the element part of the ratio. Both subparameters are coded as one to three digits. If you choose to specify one of the subparameters, you must specify both.

If you omit the DIRRATIO or specify a value of zero, IMS provides a default DIRRATIO of 1:0. If DIRRATIO specifies a non-zero value and ELEMRATIO specifies zero, IMS supplies a ratio of 1:0. This ratio causes the coupling facility to configure the OSAM structure to preclude data caching. If data caching is precluded, the OSAM structure only supports buffer invalidation processing and does not support cache data.

If you omit the DIRRATIO and ELEMRATIO subparameters, or if they fail validation of the maximum elements number, IMS provides a default ratio.

IMS supplies a default ratio of 999:1. This ratio causes the coupling facility to configure the data caching OSAM structure to optimize buffer invalidation and not data caching. While data caching might be possible, the structure provides limited space for data elements.

Related reading: For additional information about sysplex data sharing, see *IMS Version 15.4 System Administration*.

Specifies the coupling facility XI structure name for OSAM.

Using the coupling facility for OSAM data caching

The OSAM database coupling facility caching function allows you to optionally specify the caching of OSAM database buffers.

For more information, see the description of the caching option (co) parameter under [“Defining OSAM subpools”](#) on page 868.

When you specify the "cache only changed data" option and an application program modifies data in a subpool, changed data is written first to DASD then to the coupling facility. If you select the "cache all data" option and an application program requests data that is not already in a subpool or in the coupling facility, that data is either read from DASD or copied from the SB buffer into the subpool and then written to the coupling facility.

Performance varies, depending upon:

- The cache option you choose.
- The number of databases utilized.
- The database block sizes.
- The number of sharing IMS/z/OS images.

The "cache only changed data" option probably provides greater performance improvement than the "cache all data" option. If you specify the "cache only changed data" option, each data block from the selected database, once read from DASD, must be written to system memory. This action requires additional path length and cycles. The specific use of the database by your application program dictates whether this option is beneficial.

Data caching initialization processing is dependent upon the proper environment and the specification of the caching option in the subpool definition statement. The following actions are performed:

- Establish an element size of 2 KB for the coupling facility.
- Allocate a buffer prefix extension for caching subpools. The extension resides as a non-contiguous area and is anchored from the prefix. It consists of two parts:
 - A fixed-length section for asynchronous processing.
 - A variable length section for data transfer buffer lists. The number of buffer lists is dependent upon the subpool buffer size.

Example: A subpool buffer size of 6 KB requires three buffer lists and a subpool size of 0.5 KB, or 1 KB requires one buffer list. A single buffer list accommodates 2 KB of subpool buffer.

- Establish miscellaneous values for coupling facility data transfer parameters including:
 - Element and directory ratios
 - Buffer increment number (number of 256 byte segments)
 - Number of buffers in the buffer list.

The write data option is supported at the subpool level and permits the definition of each subpool with a write cache option.

Restriction: When using sequential buffering and the coupling facility for OSAM data caching, the OSAM database block size must be defined in multiples of 256 bytes (decimal). Failure to define the block size accordingly can result in ABENDS0DB PIC15 from the coupling facility. This condition exists even if the IMS system using sequential buffering is accessing the database in read-only mode.

Enabling the long busy handling function

RAMAC disk arrays sometimes cause a problem to online programs when the DASD subsystem takes a very long time to do error recovery.

This condition (known as *long busy*) might range in time from a couple of seconds to many minutes. You can avoid these excessive long wait times by defining the Multiple Area Data Sets I/O Timing (MADSIOT) keyword on the DFSVSMxx member of the IMS PROCLIB data set, thus enabling IMS system's long busy handling function.

For more information about the long busy function, see [Managing I/O errors and long wait times \(Database Administration\)](#) in *IMS Version 15.4 Database Administration*.

➤➤ MADSIOT=(*structurename* ,*iotime*) ➤➤

structurename

Specifies the name of the coupling facility list structure that IMS uses for the long busy handling function.

iotime

Specifies the maximum time (in seconds) before the long busy handling function is activated. The allowable values are 0 to 255. This value is passed to the I/O subsystem for all I/O requests to MADS. If the time interval specified expires before the request completes, the request is terminated. This explicit request timing value takes precedence over an I/O timing value specified at the volume level.

Enabling the IRLM lock timeout function

The IRLM Lock Timeout function enables you to interrupt processes that are waiting for locks for longer than a specified number of seconds.

To use this function, specify a positive decimal integer value from 1 to 32767 for the LOCKTIME parameter in the DFSVSMxx member of the IMS PROCLIB data set (or DFSVSAMP DD statement for IMS batch procedures). The LOCKTIME parameter specifies the number of seconds that IRLM waits before rejecting lock requests that have not been granted. For example, when LOCKTIME=10 is specified, IRLM waits ten seconds before rejecting lock request that have not been granted.

LOCKTIME

Specifies the IMS LOCKTIME values. You can specify LOCKTIME values in any combination of the following keywords and parameters:

BMP(xx)

Specifies the amount of time that IMS waits before lock requests for BMP regions are timed out. BMP regions include IMS BMP and JBP regions. The value, which represents time in seconds, can range 1 - 32767.

BMPOPT(ABEND | STATUS)

Specifies whether IMS ends a timed-out task abnormally (ABEND) or returns a status code to the application (STATUS).

MSG(yy)

Specifies the amount of time that IMS waits before lock requests for MSG regions are timed out. MSG regions include IMS MPP, JMP, and IFP regions, as well as DRA threads. The value, which represents time in seconds, can range 1 - 32767.

MSGOPT(ABEND | STATUS)

Specifies whether IMS ends a timed-out task abnormally (ABEND) or returns a status code to the application (STATUS).

Updating IMS LOCKTIME values does not affect the lock timeout value in an IRLM. To change the lock timeout value in an IRLM, use the existing **MODIFY IRLM** command.

Recommendation: Generally, use the same timeout values for both IMS and IRLM. When using two values in IMS, setting the IRLM timeout value to the lower of the two IMS values allows IMS and IRLM to act together. When more than one IMS is identified to the same IRLM, workload conditions might require using different timeout values across IMS systems. In such a case, note the following:

- Using a lower timeout value in IRLM results in lock requests to wait until the time spent for waiting equals the lowest IMS LOCKTIME value.
- Using a higher timeout value in IRLM results in lock requests to wait beyond the IMS time because IRLM does not call IMS until the IRLM timeout value is exceeded.

When no value is specified for the LOCKTIME parameter, IRLM issues message DXR162I to indicate that a task has held (or has been waiting for) a lock. The first message is issued after five minutes; thereafter, messages are issued at intervals of one minute. RMF records (type 79.15) can be formatted for more information about the task that is holding (or waiting for) the lock.

When a value is specified for the LOCKTIME parameter, IRLM interrupts all the dependent regions that have been waiting for a lock for longer than the number of seconds specified by the LOCKTIME parameter. An ABENDU3310 is issued for every dependent region that waits for longer than the number of seconds specified by the LOCKTIME parameter. The number of seconds can be changed after IMS initialization by issuing the command `MODIFY, ir1lmproc, SET, TIMEOUT=nn`.

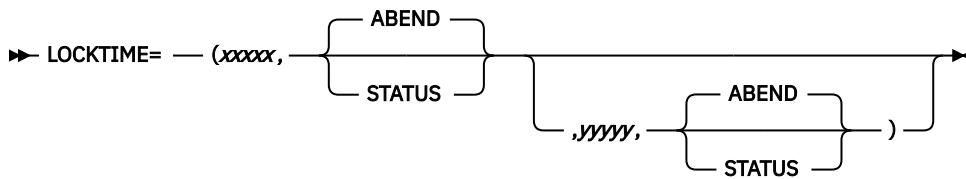

ABEND

Specifies that an abend occurs when the value specified for LOCKTIME is exceeded. ABEND is the default.

STATUS

Specifies that a status code of BD be returned when the value specified for LOCKTIME is exceeded.

xxxxx

When LOCKTIME=(xxxxx), xxxxx specifies the online timeout value in seconds. Valid values are from 1 to 32767. Optionally, you can specify ABEND or STATUS after xxxxx to determine whether an abend occurs or a status code is issued when the xxxxx value is reached. If a second timeout value is not specified, a value of xxxxx is also used for batch or a BMP. Unless xxxxx is specified as a multiple of the local IRLM deadlock timer value, the timeout occurs at the next deadlock timer interval.

yyyyy

If specified in the DFSVSMxx PROCLIB member after xxxxx, defines the timeout value, in seconds, for BMPs or JBPs. Valid values are from 1 to 32767. Optionally, you can specify ABEND or STATUS after yyyyy to determine whether an abend occurs or a status code is issued when the yyyyy value is reached.

If specified in the DFSVSAMP PROCLIB member after xxxxx, defines the timeout value, in seconds, for batch. Valid values are from 1 to 32767. Optionally, you can specify ABEND or STATUS after yyyyy to determine whether an abend occurs or a status code is issued when the yyyyy value is reached.

Unless xxxxx and yyyyy are specified as a multiple of the local IRLM deadlock timer value, the timeout occurs at the next deadlock timer interval. For example, if xxxxx is 5 seconds and yyyyy is not specified, and the deadlock timer value is (3,1), the timeout occurs at 6 seconds because that is a multiple of 3.

Preventing transactions from being terminated when HALDB partitions are unavailable

Use the PPUR= control statement on the DFSVSMxx member to prevent transactions with a processing option of PROCOPT=GOx from being terminated if a HALDB partition is unavailable due to a database command in progress. This condition would cause either STATUSGG or STATUSBA to be issued.

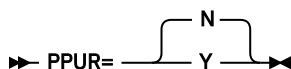

N

Do not prevent STATUSGG or STATUSBA from being issued if a HALDB partition is unavailable because a database command is in progress.

Y

If a HALDB partition is being accessed by a transaction with a processing option of PROCOPT=GOx, and the partition is unavailable due to a database command in progress, terminate the transaction and reschedule it.

Preventing DBRC calls for HALDB version verification

Use the PSELNODBRC control statement in the DFSVSMxx member of the IMS PROCLIB data set to prevent the Database Recovery Control facility (DBRC) from being called when partition selection (either

with key range selection or with a partition selection exit) finds that a key requested by an application call is not in the range of any partitions.

Calling DBRC in this case can cause performance degradation especially when many similar application calls are made or when many other applications or utilities are using the RECON data set.

➤ PSELNOBRC ➤

PSELNOBRC

Specify this keyword if you want to prevent DBRC from being called when partition selection (either with key range selection or with a partition selection exit) finds that a key requested by an application call is not in the range of any partitions.

Otherwise, omit this keyword.

Related concepts

[Overview of DBRC \(System Administration\)](#)

Resuming an online reorganization for HALDBs during IMS warm or emergency restart

To resume the online reorganization of a high-availability large database (HALDB) during an IMS warm or emergency restart, use the FFROLR= control statement in the DFSVSMxx member of the IMS PROCLIB data set.

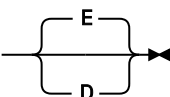
➤ FFROLR=  ➤

The diagram shows the control statement FFROLR= followed by a large right-facing curly bracket. Inside the bracket, the letter 'E' is positioned above the top curve and the letter 'D' is positioned below the bottom curve. The bracket ends with a right-pointing arrowhead.

E

Specifies that after an IMS warm or emergency restart, IMS should attempt to automatically resume the OLREORG process that it owned before the restart. This is the default.

D

Specifies that after an IMS warm or emergency restart, IMS does not automatically resume the OLREORG process that it owned before the restart. Instead, the RECON is updated to release the ownership of the OLREORG process when IMS restarts.

Discarding preallocated SDEP control intervals

When the SDEP scan and delete utilities are invoked, they write out all preallocated control intervals (CIs). These CIs contain no user data. When the CIs are written to disk, the SDEP utilities can either maintain the preallocated CIs for subsequent SDEP inserts or discard them.

If you want the SDEP utilities to discard the preallocated CIs, use the SDEPQCI keyword of the DFSVSMxx member of the IMS PROCLIB data set. By using SDEPQCI, you do not have to include the QUITCI utility control statement in each SYSIN member. SDEPQCI makes QUITCI the default for the SDEP utilities.

➤ SDEPQCI= *utilityoption* ➤

SDEPQCI=

Specifies that QUITCI is the default option for the SDEP scan and delete utilities. If you do not specify SDEPQCI, the SYSIN of the utility JCL determines how the preallocated CIs are treated.

utilityoption

One-character alphabetic field that identifies which SDEP utilities use the QUITCI function. There is no default.

S

The SDEP scan utility uses the QUITCI function.

D

The SDEP delete utility uses the QUITCI function.

B

Both the scan and delete SDEP utilities use the QUITCI function.

If you specify a value other than S, D, or B, message DFS2835I is issued.

Preventing a /DBRECOVERY command for a database that has INDOUBT EEQEs

When the NODBR keyword is specified, a /DBRECOVERY command is not processed for any database that has an INDOUBT Extended Error Queue Element (EEQE), and message DFS0488I RC=43 is issued.

►► NODBR ◄◄

This statement causes a /DBRECOVERY command to fail if the command is issued against a database that has INDOUBT EEQEs. NODBR does not apply to Fast Path databases.

Related reference

[/DBRECOVERY command \(Commands\)](#)

Related information

[DFS0488I \(Messages and Codes\)](#)

Removing the limit for the number of DFS3314W messages issued

Currently up to six DFS3314W messages can be issued per Data Capture Exit. This limit can be removed by specifying the ALL3314W control statement in the DFSVSMxx member.

►► ALL3314W ◄◄

ALL3314W

This statement indicates the user wants no limit to the number of DFS3314W messages issued. The current limit is six for each Data Capture EXIT.

Note: ALL3314W is applicable to Full Function DB only.

DFSYDTx member of the IMS PROCLIB data set

Use the DFSYDTx member of the IMS PROCLIB data set to specify the OTMA client descriptors and the OTMA destination descriptors that are built during IMS initialization.

The x on DFSYDTx is the IMS nucleus suffix.

OTMA client descriptor syntax and parameters

Use the OTMA client descriptor to specify attributes, limits, and types of support for an individual OTMA client.

To specify global attributes that apply to all OTMA clients, use the DFSOTMA global client descriptor.

The values that you can specify for an individual OTMA client include:

- The use of a DRU exit
- Message flood protection
- Send-then-commit (CM1)/commit-then-send (CM0) ACK timeout value

- Support for multiple active resume tpipe requests
- The minimum and maximum numbers of save area prefix control blocks to allocate
- Support for sending ALTPCB outputs back to the initiating IMS Connect commit-then-send send/receive calls

An OTMA client descriptor can also be used to set the global tpipe limit for all the OTMA members or clients.

OTMA client descriptors are optional.

You can specify a maximum of 254 OTMA client descriptors in the DFSYDTx member of the IMS PROCLIB data set. If you do not use the DFSOTMA descriptor, you can specify 255 OTMA client descriptors.

Client descriptors are always loaded from the DFSYDTx PROCLIB member regardless of the IMS restart type. There are no checkpoint log records for client descriptors.

Format

You can use up to 50 lines in the specification of a descriptor. Columns 1 - 18 must be the same for each line. You must delimit all parameters by using a blank space.

The following table includes information about the format of an OTMA client descriptor.

Column	Contents	Description
1	M	Identifies this descriptor as an OTMA client descriptor.
2	Blank	This field is left blank.
3-18	A 1- to 16-character OTMA client name	<p>1- to 16-character OTMA client name, left-aligned, and padded with blanks if necessary. This parameter is required and positional. OTMA client names must be unique.</p> <p>For IMS Connect, this name must match the value of the MEMBER parameter on a DATASTORE configuration statement.</p> <p>The OTMA client name must follow the resource naming conventions:</p> <ul style="list-style-type: none"> • Can use only characters A - Z, 0 - 9, @, \$ • Cannot contain embedded blanks • Cannot be a reserved word (for example, "TO" or "SECURITY") • Cannot begin with "DFS" or "DBCDM" • Cannot be an IMS keyword (for example, "LINE" or "NODE")
19	Blank	This field is left blank.
20-72	OTMA client descriptor parameters	Enter the parameters in any order. Separate parameters by using a blank space.
73–80	Sequence numbers	These columns are ignored by IMS.

Parameters

You can specify the following parameters on the OTMA client descriptor:

Important: If an invalid parameter is specified on an OTMA client descriptor, IMS rejects the parameter by issuing a DFS2385E error message with the syntax error information. IMS continues processing the rest of the parameters in the client descriptor and takes one of the following actions when the processing completes:

- If **ABEND=YES** is specified in the DFSOTMA descriptor, IMS initialization terminates abnormally with ABEND0078.
- If **ABEND=NO** is specified in the DFSOTMA descriptor, IMS accepts the valid parameters and IMS initialization completes without ABEND 0078.

For more information on the **ABEND=** parameter, see DFSOTMA descriptor syntax and parameters.

ALTPCBE=NO | YES

Specifies whether the OTMA shared queues alternate PCB (ALTPCB) output, which is originated from an OTMA front-end IMS and generated at the back-end IMS, must be delivered to the front-end IMS for the OTMA client. This parameter is optional and defaults to **ALTPCBE=NO**.

If the super member function is activated for the ALTPCB output at the shared queues back-end IMS, the super member takes precedence.

DRU=exit_name

8-character OTMA Destination Resolution exit routine name. Duplicate exit routine names are allowed.

DSAP

Specifies the minimum allocation of save area prefixes (SAPs) for this OTMA client.

Valid values are 18 - 500.

A **DSAP** value specified on an OTMA client descriptor overrides the **DSAP** value specified on the DFSOTMA descriptor, if any.

If the **DSAP** parameter is specified in the DFSOTMA descriptor, the DFSOTMA specification determines the default value of the **DSAP** parameter for OTMA clients. If the **DSAP** parameter is not specified on the DFSOTMA descriptor or no DFSOTMA descriptor exists, **DSAP=18** is the default for an OTMA client.

DSAPMAX

Specifies the maximum allowable number of SAPs that this OTMA client can have allocated at the same time.

Valid values are 18 - 500. If the value that is specified on the **DSAPMAX** parameter is less than the value of the **DSAP** parameter, a value of 500 is used.

A **DSAPMAX** value specified on an OTMA client descriptor overrides the **DSAPMAX** value specified on the DFSOTMA descriptor, if any.

If the **DSAPMAX** parameter is specified in the DFSOTMA descriptor, the DFSOTMA specification determines the default value of the **DSAPMAX** parameter for OTMA clients. If the **DSAPMAX** parameter is not specified on the DFSOTMA descriptor or no DFSOTMA descriptor exists, **DSAPMAX=500** is the default for an OTMA client.

INPT=

A 1- to 5-digit decimal integer that indicates the maximum flood limit for input messages from this member.

Valid values are 200 - 65000, or 0. If the value is 1 - 200, it is treated as 200. If the value is over 65000, a value of 65000 is used.

When this value is higher than the default global flood limit of 8000, the default global flood limit will be changed to this value. If more than one client descriptor has input (INPT) values that are higher than the default global flood limit, the highest value will become the default global flood limit.

If you specify a value of 0, OTMA deactivates the input message flood detection for this client; however, OTMA still includes the input messages from this client in the calculation of the global message counts.

This value might also affect the global flood limit:

- If the **INPT** parameter is not specified for the OTMA system client name DFSOTMA descriptor, then the global flood limit is determined by these criteria:
 - If a member flood limit through **INPT** parameter is specified for a client descriptor and the value is higher than the default global flood limit of 10000, then the global flood limit is set to this value. If more than one client descriptor has **INPT** values higher than the default global flood limit, then the global flood limit is set to the highest **INPT** value.
 - If there are no member flood limit **INPT** higher than the default global flood limit of 10000, then the global flood limit is set to 10000.
- If the **INPT** parameter is specified for the DFSOTMA descriptor, then the global flood limit is set to its value.

Internally, each OTMA input message is represented by a transaction instance block (TIB). Therefore, within the context of OTMA, the terms TIB and input message are generally synonymous.

When message flood control is active for the OTMA client and the number of input messages from this client reaches 80% of the **INPT=** value, OTMA issues the DFS1988W warning message to the master terminal operator (MTO) and system console, and issues a protocol messages to the OTMA client. Thereafter, OTMA reissues DFS1988W at every 5% increase in the message count, until the number of messages reaches the maximum.

When the message flood limit is reached, OTMA rejects all the new input transactions from the member. OTMA issues DFS1989E error message to the console and MTO, and a server state protocol command to the OTMA client. The OTMA client can then choose to take corrective action, such as rerouting new transaction requests to a different IMS system. The **/DISPLAY TMEMBER** command shows FLOOD.

When the input messages in the system are processed and the number of total TIBs in the system is 50% or less of the global limit, the flood status is relieved. A DFS0767I message is sent to the MTO and system console, and a server state protocol message is sent to the OTMA client.

LIMITRTP

Specifies the maximum number of active **RESUME TPIPE** requests for any tpipes of this OTMA client and, if **MULTIRTP=YES** is not already specified, enables support for multiple active resume tpipe requests for the tpipes that are created for this client.

Valid values are a 2- to 4-digit decimal integer between 10 and 4095. IMS treats values between 0 and 9 as 10. IMS treats any 4-digit decimal number greater than 4095 as 4095.

If the **MULTIRTP=** parameter is not specified when the **LIMITRTP** parameter is specified, the **MULTIRTP** setting is automatically set to YES. However, if **MULTIRTP=NO** is specified, the **LIMITRTP** parameter is ignored.

The default value for **LIMITRTP** parameter is 100.

If the maximum number of **RESUME TPIPE** requests are already active, any additional requests that are received are queued and will become active when an currently active request ends.

When the **LIMITRTP** parameter is specified on the DFSOTMA global client descriptor, it is used to set the default only for clients that do not specify the **LIMITRTP** parameter. Also, if the **MULTIRTP** parameter is not specified on the DFSOTMA descriptor, the specification of **LIMITRTP** parameter changes the system default to **MULTIRTP=YES**.

For the super member function, the **LIMITRTP** value of the first OTMA client that connects to the IMS defines the **LIMITRTP** value of the super member.

Using the OTMA client descriptor is the only way to specify or change the **LIMITRTP** value. OTMA clients cannot set or change the **LIMITRTP** value in a client bid protocol message.

LOGSTR=NO | YES

Specifies whether the first 255 bytes of network security credentials, which includes a network user ID or network session ID, or both, is included in the RACF SMF process records. The network security

credentials must exist in the security-data section of the input OTMA message prefix to be included in the SMF records. The format of network user ID and network session ID in the SMF records is identical to the corresponding format in the OTMA security prefix. This parameter is optional and defaults to **LOGSTR=NO**.

MAXTP=

A 1- to 6-digit decimal integer from 0 - 999999 that defines the maximum number of tpipes that this OTMA client member can have in an IMS system. If 0 is specified, OTMA does not monitor or limit the number of tpipes that this OTMA client can have in the IMS system. If a value of 1 to 200 is specified, it is treated as 200. Any number over 999999 is rejected.

Before an OTMA member's **MAXTP** value is reached, IMS issues message DFS4382W as a warning when the number of tpipes reaches a threshold through a percentage of the maximum number that is either 80% or a user-specified percentage as shown in the **MAXTPWN** value. OTMA also issues a protocol command **TMAMNTR** (X'3C' Resource Monitor) message with the warning status of the server to the OTMA client. After the threshold is reached, OTMA continues creating new tpipes until the number of tpipes reaches the maximum number of tpipes allowed as defined by the **MAXTP** value.

If the total number of tpipes from this client reaches the maximum number, OTMA rejects all new tpipes creation requests from the OTMA member with a NAK with sense code X'29'. IMS sends DFS4383E error message to the system console and master terminal operator (MTO), and notifies the OTMA client with an OTMA protocol message. The **/DISPLAY TMEMBER** command shows "MAX TPIPE" in the user status of the client member.

When the number of tpipes for the OTMA member drops to 50% of the maximum number, or a user-specified percentage through **MAXTPRL** parameter, IMS issues message DFS4384I to the IMS system console and MTO, and notifies the OTMA member with a heartbeat protocol message.

If **MAXTP** parameter is not specified in the DFSOTMA descriptor, the OTMA client descriptor with the highest **MAXTP** value defines a global warning threshold for the total number of tpipes in the system for all OTMA clients. When this global warning threshold is reached, IMS issues message DFS4385W to the MTO and system console, and OTMA issues a server state protocol command to all OTMA clients. IMS does not prevent the creation of new tpipes.

When the global tpipes count falls to 80% of the global tpipes warning threshold or below, IMS issues message DFS4386I to the MTO and system console and OTMA notifies all OTMA clients with another protocol message.

When **MAXTP** parameter is specified in the DFSOTMA descriptor, IMS uses the DFSOTMA **MAXTP** value as the global warning limit instead of the highest **MAXTP** value among the OTMA client descriptors and the warning thresholds are different. For more information about the effect of the DFSOTMA **MAXTP** parameter, see ["DFSOTMA descriptor syntax and parameters"](#) on page 902.

The **/DISPLAY OTMA** and **/DISPLAY TMEMBER** commands result in displays of the current numbers of tpipes and **MAXTP** value for members and OTMA server using the function.

Note:

If **LITETP=YES** is specified in the DFSOTMA descriptor, the lightweight tpipes function will be enabled. As a result, tpipes that are created in a shared queues back-end IMS system use less storage. To take this reduction in storage size into account, a weighting factor is applied to these lightweight tpipes when calculating the total number of tpipes. An adjusted tpipes count is used instead of the total tpipes count, which consists of the number of front-end tpipes plus the number of back-end tpipes, to check if the IMS system reached the maximum tpipes limit.

The adjusted tpipes count is calculated as follows:

A: the number of front-end tpipes (total tpipes - back-end tpipes)

B: the number of back-end tpipes

W: the weighting factor

adjusted tpipes count=A+(B*W)

For more information on the **LITETP=** parameter, see DFSOTMA descriptor syntax and parameters.

MAXTPBE=YES | NO

Specifies whether (YES) or not (NO) the **MAXTP** must be monitored when this IMS is a shared queues back-end system processing a front-end initiated OTMA input transaction at the application GU time. This is designed for member when **MAXTP** parameter is specified. It is ignored if the member does not have **MAXTP** parameter specified.

A **MAXTPBE** value specified on an OTMA client descriptor overrides the **MAXTPBE** value specified on the DFSOTMA descriptor, if any.

If the **MAXTPBE** parameter is specified in the DFSOTMA descriptor, the DFSOTMA specification determines the default value of the **MAXTPBE** parameter for OTMA clients. If the **MAXTPBE** parameter is not specified on the DFSOTMA descriptor or no DFSOTMA descriptor exists, **MAXTPBE=YES** is the default for an OTMA client.

MAXTPRL=

Specifies the relief level for the **MAXTP** value as a percentage of the maximum number of tpipes that this client can have. Valid values are 50 - 95. If a value less than 50 is specified, it is set to 50. Values over 95 are set to 95.

A **MAXTPRL** value specified in an OTMA client descriptor overrides the **MAXTPRL** value that is specified in the DFSOTMA descriptor, if any.

If the **MAXTPRL** parameter is specified in the DFSOTMA descriptor, the DFSOTMA specification determines the default value of the **MAXTPRL** parameter for OTMA clients. If the **MAXTPRL** parameter is not specified on the DFSOTMA descriptor or no DFSOTMA descriptor exists, **MAXTPRL=50** is the default for an OTMA client.

If **LITETP=YES** is specified in the DFSOTMA descriptor, the adjusted tpipe count is used instead of the actual number of tpipes in use to check if the IMS system reached the maximum tpipe limit. See the **LITETP=** parameter in the DFSOTMA descriptor for the calculation of the adjusted tpipe count.

MAXTPWN=

Specifies the warning level for the **MAXTP** value as a percentage of the maximum number of tpipes that this client can have. Valid values are 50 - 95. If a value less than 50 is specified, it is set to 50. Values over 95 are set to 95.

A **MAXTPWN** value specified on an OTMA client descriptor overrides the **MAXTPWN** value that is specified on the DFSOTMA descriptor, if any.

If the **MAXTPWN** parameter is specified in the DFSOTMA descriptor, the DFSOTMA specification determines the default value of the **MAXTPWN** parameter for OTMA clients. If the **MAXTPWN** parameter is not specified on the DFSOTMA descriptor or no DFSOTMA descriptor exists, **MAXTPWN=80** is the default for an OTMA client.

MULTIRTP=YES | NO

Specifies whether or not a given TPIPE supports multiple active resume tpipe requests.

When **MULTIRTP=YES** is specified, the tpipes that are created for this client support multiple active resume tpipe requests. Commit-then-send (CM0) output messages or callout request messages from IMS application programs can be retrieved by multiple client instances in parallel.

When **MULTIRTP=NO** is specified, the tpipes that are created for this client support only one active resume tpipe request at a time. IMS commit-then-send (CM0) messages or callout messages are delivered to client one message at a time. Any subsequent **RESUME TPIPE** requests that are received while the first one is still active are queued.

A **MULTIRTP** value specified on an OTMA client descriptor overrides the **MULTIRTP** value specified on the DFSOTMA descriptor, if any.

If the **MULTIRTP** parameter is specified in the DFSOTMA descriptor, the DFSOTMA specification determines the default value of the **MULTIRTP** parameter for OTMA clients. If the **MULTIRTP** parameter is not specified on the DFSOTMA descriptor or no DFSOTMA descriptor exists, **MULTIRTP=NO** is the default for an OTMA client.

A **MULTIRTP** specification made in a client bid request by an OTMA client overrides a **MULTIRTP** specification made in an OTMA client descriptor.

SENDALTP=NO | YES

Specifies whether or not ALTPCB output needs to be sent to IMS Connect.

When **SENDALTP=YES** is specified, ALTPCB output is sent back to the IMS Connect client that originally initiated the commit-then-send send/receive call. If the OTMA destination descriptor or DFSYDRU0 user exit specifies a member that is not the initial IMS Connect client, and the member is not a super member, the output is saved in a TPIPE hold queue.

When **SENDALTP=NO** is specified, ALTPCB output for IMS Connect is kept in a TPIPE hold queue. It can be retrieved by a RESUME TPIPE call.

This parameter is optional and defaults to **SENDALTP=NO**.

TODUMP=NO | YES | U243

Specifies whether the pseudo ABENDU0243 is needed at application GU time for one of the following reasons:

- An OTMA transaction expired.
- An OTMA input transaction that requires a new tpipe is rejected because the maximum number of tpipes as defined by the **MAXTP=** parameter is reached.
- An OTMA input transaction that requires a new tpipe is rejected when the tpipe flood limit that is defined in the INPT parameter has been reached.

This parameter is optional and defaults to **TODUMP=NO**.

If you use IMS shared queues and the **TODUMP=** parameter is specified, the parameter needs to be set in the OTMA client descriptor in the front-end IMS system.

If the **TODUMP=** parameter is specified in the DFSOTMA descriptor, the value of the DFSOTMA **TODUMP=** parameter is used by OTMA clients that do not specify the **TODUMP=** parameter.

You can specify one of the following values for this parameter:

NO

If NO is specified, IMS discards the affected transaction without the ABENDU0243 to save CPU cycles. Because pseudo ABENDU0243 is not issued for each affected transaction at GU time, no additional IMS type X'56' log records are written. However, IMS writes a type X'67D0' diagnostic information log record for each affected transaction at GU time.

YES

If YES is specified, a pseudo ABENDU0243 with message DFS554A and symptom dump is generated at the GU time for each expired or rejected OTMA transaction. If you specify YES, the console might become flooded and the IMS system might require more CPU cycles if many transactions are expired or rejected.

U243

If U243 is specified, a pseudo ABENDU243 is generated without message DFS554A and without symptom dump for each affected transaction at GU time. To identify the transactions that pseudo ABENDU243 is issued for, see the IMS type X'56' log record.

T/O=

A 1- to 3-digit decimal integer 0 - 255. It indicates the timeout value, in seconds, for OTMA to wait for acknowledgments. If the value is over 255, OTMA uses 255. If the value is 0, OTMA deactivates the timeout function. The default value is 120.

ACK timeout intervals can be specified for the following types of OTMA output messages:

- Transaction messages that are sent to a remote IMS system for processing
- Some send-then-commit (CM1) response messages
- Commit-then-send (CM0) response messages

You can override the descriptor timeout value by taking one of the following actions:

- Issuing the **/START TMEMBER TIMEOUT** command to reset the timeout value
- Specifying a lower timeout value by using the client bid of an OTMA client, such as IMS Connect.

The **T/O** parameter also applies to acknowledgments for messages that are sent to remote IMS systems by way of an IMS-to-IMS TCP/IP connection. For these types of messages, if the timeout interval expires before an acknowledgment is received, OTMA reroutes the message to the timeout queue designated by IMS Connect or to the OTMA default timeout queue, DFS\$TOQ.

Example

The following example shows an OTMA client descriptor. The descriptor, HWSICON1, specifies the DFSYDRU0 exit for TMEMBER HWSICON1.

```
M HWSICON1          DRU=DFSYDRU0
```

Related reference

[Message-control information section \(Communications and Connections\)](#)

[“DFSOTMA descriptor syntax and parameters” on page 902](#)

Use the optional DFSOTMA descriptor to define global and default attributes, limits, and types of support that apply to all OTMA clients.

OTMA destination descriptor syntax and parameters

Use OTMA destination descriptors to define message switch destinations from the ALT IOPCB for OTMA clients, such as IMS Connect or IBM MQ, or non-OTMA clients, such as SNA terminals or printers. The OTMA destination descriptors can also be used to define destinations for synchronous callout messages and messages that are destined for remote IMS systems on a TCP/IP connection.

If the SENDALTP function is activated, and the message switches destination from the ALT IOPCB is the IMS Connect client that initiates a commit-then-send send-receive call, the ALT IOPCB output message will be delivered back to the IMS Connect client through the incoming TPIPE. The output message will not be queued to a TPIPE hold queue. This behavior applies to IMS Connect clients that use super member.

Subsections:

- [“Creating and modifying destination descriptors” on page 895](#)
- [“Destination descriptor format” on page 896](#)
- [“Common parameters” on page 896](#)
- [“IMS Connect parameters” on page 898](#)
- [“IMS synchronous program switch parameters” on page 899](#)
- [“IBM MQ parameters” on page 900](#)
- [“Example” on page 901](#)
- [“IBM MQ example” on page 901](#)

Creating and modifying destination descriptors

The OTMA destination descriptors are specified in the OTMA DFSYDTx member of the IMS.PROCLIB data set. You can use them to externalize message switch definitions that would otherwise be coded in the OTMA routing exit routines OTMAYPRX and DFSYDRU0. The OTMA destination descriptors can be used instead of the OTMAYPRX and DFSYDRU0 exit routines or in addition to them.

Destination descriptors are loaded from the DFSYDTx member of the IMS.PROCLIB data set during IMS cold start or **/ERESTART COLDCOMM** processing, or from the X'4035' checkpoint log records during IMS restart by the **/NRESTART** or **/ERESTART** command.

Alternatively, you can dynamically add, update, or delete OTMA destination descriptors with the following type-2 commands:

- **CREATE OTMADESC**

- **UPDATE OTMADESC**
- **DELETE OTMADESC**

A restart of IMS is not required; in addition, any changes that you make with these type-2 commands persist across warm and emergency restarts, when the changes are read from the IMS logs.

Use the **QUERY OTMADESC** command to display the characteristics of a specific destination routing descriptor.

For callout requests to IMS Connect clients, you can use the OTMA destination descriptors to specify adapter and converter names for XML message conversion.

For IMS-to-IMS TCP/IP communications, you can use the OTMA destination descriptor to route ALTPCB output to a remote IMS system over a TCP/IP connection that is managed by IMS Connect. You can optionally specify the transaction to run on the remote IMS system.

A descriptor that matches the destination sets the default routing as either IMS Connect, IBM MQ, or non-OTMA, as coded on the descriptor. OTMA routing exits are not called if they exist. The OTMA routing descriptors override the exits unless EXIT=Y is specified for the descriptor.

Unless you change the limit, you can specify a maximum of 510 OTMA destination descriptors in the DFSYDTx member of the IMS PROCLIB data set. You can increase the maximum number up to 4095 by creating a DFSOTMA descriptor and specifying a new maximum on the DDESCMAX parameter. Increasing the number of OTMA destination descriptors increases the amount of ECSA storage that is used.

Destination descriptor format

Up to 50 lines can be used in the specification of a descriptor. Columns 1 - 10 must be the same for each line.

Table 83. Format of an OTMA destination descriptor

Column	Contents	Description
1	D	Identifies this descriptor as an OTMA destination descriptor.
2	Blank	This field is left blank.
3-10	A 1- to 8- character destination name	The destination name must be left-aligned and padded with blanks if necessary. The destination name can be masked by ending it with an asterisk (*). OTMA destination names must be unique. This is a required, positional parameter.
11	Blank	This field is left blank.
12-72	Descriptor parameters	Enter the parameters in any order. Separate parameters by using a blank space.
73-80	Sequence numbers	These columns are ignored by IMS.

Common parameters

You can specify the following parameters on the OTMA destination descriptor:

EXIT=NO | YES

For descriptors with a TYPE= value other than IMSTRAN, this optional parameter specifies whether the OTMA routing exits (OTMAYPRX and DFSYDRU0) can override the descriptor routing information of the message switch destination from the ALT IOPCB. The valid values are YES and NO. The default is NO.

For TYPE=IMSTRAN descriptors, this parameter specifies whether the IMS user exit (DFSCMUX0) can override the descriptor routing information for late or redundant response messages.

If you specify EXIT=YES when TYPE=IMSCON is specified and the return code of the DRU exit is set to 0, the SENDALTP flag in the output parameter list of the DRU exit, if set, can be used to override the SENDALTP parameter of the destination descriptor.

SMEM=NO | YES

Specifies whether this destination is a super member. This parameter is optional and the default is SMEM=NO. When SMEM=YES, TMEMBER is the 1- to 4-character super member name.

If you specify this parameter when TYPE=NONOTMA or TYPE=MQSERIES, it is ignored.

Because the SENDALTP function applies to IMS Connect clients that use super members, if you enable this parameter when TYPE=IMSCON and the SENDALTP function is activated, the ALTPCB output message that is triggered by an IMS Connect commit-then-send Send-Receive call is sent back to the input client TMEMBER.

SYNTIMER=value

An optional parameter that specifies the timeout value for a synchronous callout process. When the timeout value is reached, the IMS application that issues the synchronous callout request receives a X'100' return code and a X'104' reason code. The message is discarded.

If **TYPE=NONOTMA** or **TYPE=MQSERIES** is specified in the OTMA destination descriptor, or when the descriptor is used to route a non-synchronous callout message, this parameter is ignored. If **TYPE=IMSTRAN** is specified, this parameter is the timeout value for synchronous program switch ICAL calls.

The value of this parameter should be expressed in 100th of the timeout value in seconds. The valid range is 0–999999. The system default is 10 seconds. If you specify a value that is not within the valid range:

- If **SYNTIMER=0**, the system default is used.
- If the **SYNTIMER** value is larger than 999999, you'll receive error message DFS2385E. No default value is set.

The **AIBRSFLD** parameter in the DL/I ICAL SENDRECV call can override the **SYNTIMER** value when specified. Depending on the specification of the two parameters, the timeout value might vary:

- When the **AIBRSFLD** parameter is set:
 - If the **SYNTIMER** parameter is set, the smaller value is used.
 - If the **SYNTIMER** parameter is not set or is invalid, the **AIBRSFLD** value is used.
- When the **AIBRSFLD** parameter is not set or is invalid:
 - If the **SYNTIMER** parameter is set, the value of this parameter is used.
 - If the **SYNTIMER** parameter is not set or is invalid, the system default 10 seconds is used.

For more information about the usage of the **AIBRSFLD** parameter, see [ICAL call \(Application Programming APIs\)](#).

TMEMBER=name

A 1- to 16-character OTMA TMEMBER name. When SMEM=YES, TMEMBER is the 1- to 4-character super member name.

- For TYPE=IMSCON and TYPE=MQSERIES, this parameter is required.
- For TYPE=IMSTRAN, this parameter is optional. It can be used with the TPIPE parameter to queue a late response from a synchronous program switch to the specified OTMA TMEMBER.
- For TYPE=NONOTMA, this parameter is ignored.

TPIPE=name

A 1- to 8-character TPIPE name. The default is the destination name.

- For TYPE=MQSERIES, the destination is used for the TPIPE if this parameter is omitted.
- For TYPE=IMSCON, this parameter is omitted if the SENDALTP function is activated for an ALTPCB output message that is triggered by an IMS Connect commit-then-send send-receive call. When the

SENDALTP function is activated, the ALTPCB output message is sent back to the input client TPIPE of the originated commit-then-send send-receive call.

- For TYPE=IMSTRAN, this parameter is optional. It can be used with the TMEMBER parameter to queue a late response from a synchronous program switch to the specified OTMA TMEMBER.
- For TYPE=NONOTMA, this parameter is ignored.

TYPE=type

Specifies what type of destination the descriptor is for. This parameter is required. The valid values are:

IMSTRAN

IMS transaction for synchronous program switch

IMSCON

IMS Connect client

NONOTMA

Non-OTMA destination

MQSERIES

IBM MQ

USERID=user_ID

A 1- to 8-character user ID used for security checking by the remote IMS system that is specified in the RMTIMS parameter. If not specified, the user ID from the IMS application that issued the ISRT call is used.

This is an optional parameter for TYPE=IMSCON and TYPE=MQSERIES descriptors. It is ignored for other descriptor types.

When TYPE=MQSERIES is set for the descriptor, this parameter specifies the MQMD_USERIDENTIFIER value. This field allows the descriptor to override the default user ID in the MQ message descriptor structure. You can specify the value *USERID* to use the IMS user ID from the program specification table (PST).

IMS Connect parameters

The TMEMBER, TPIPE, SMEM, SYNTIMER, EXIT, and USERID parameters are valid for IMS Connect descriptors (TYPE=IMSCON), as well as the following additional parameters:

ADAPTER=

A 1- to 8-character name of the adapter that identifies the IMS Connect adapter to be used on these messages. For example, you can specify an adapter for XML transformation. This parameter is optional. If you specify this parameter, CONVRTR= is also required.

CONVRTR=

A 1- to 8-character name of the converter to be used by the adapter specified on ADAPTER=. This parameter is required when TYPE=IMSCON if the ADAPTER parameter is specified.

RMTIMS=

A 1- to 8-character name of the remote IMS system to which messages routed to this descriptor are sent. This value is the same value specified on the ID parameter of a DATASTORE statement in the HWSCFGxx member of the IMS PROCLIB data set of a remote IMS Connect instance. If specified, the RMTIMSCON parameter must also be specified.

RMTIMSCON=

A 1- to 8-character name of a connection to a remote IMS Connect instance. This value must match the value specified on the ID parameter of an RMTIMSCON statement in the HWSCFGxx member of the IMS PROCLIB data set of a local IMS Connect instance. If specified, the RMTIMS parameter must also be specified.

RMTSEC=E | C | N

An optional parameter that sets the security flag in an OTMA ALTPCB output message that is sent to a remote IMS system through IMS-to-IMS TCP/IP communications. The remote IMS system uses this

security flag setting in the output message only if the input message does not have a security flag and the remote IMS OTMA security is set to PROFILE. The default is RMTSEC(F).

F

OTMA RACF security is set to FULL.

C

OTMA RACF security is set to CHECK.

N

OTMA RACF security is set to NONE.

RM TTRAN=

A 1- to 8-character name of the transaction to use at the remote IMS. This is an optional parameter. If not specified, the transaction in the start of the message is used.

When the RM TTRAN is specified, OTMA passes the transaction code to IMS Connect. IMS Connect inserts the transaction code into the message immediately before the application data. Any transaction code that is specified by the sending application program is retained by OTMA in the application data section of the message.

For example, if the message received from the application program is LLZZMSGDATA, OTMA inserts 8 bytes between LLZZ and MSGDATA to hold the transaction code specified on the RM TTRAN parameter, so that the message sent by OTMA to the remote IMS system is LLZZTRANCODEMSGDATA.

If a transaction code is specified by both the OTMA destination descriptor and the sending application program, both transaction codes must be accounted for at the receiving IMS system.

SENDALTP=NO | YES

Specifies whether or not an ALTPCB output that is triggered by an IMS Connect commit-then-send send-receive call needs to be sent back to the originated IMS Connect client.

When SENDALTP=YES is specified, the ALTPCB output is delivered back to the client that initiates the call. When SENDALTP=NO is specified, the ALTPCB output for IMS Connect is kept in a TPIPE hold queue so that a Resume TPIPE request can retrieve it later.

If the SENDALTP function is activated at the member or datastore level, when IMS processes an ALTPCB output with SENDALTP=NO specified in the destination descriptor, the message level setting through OTMA destination descriptor overrides the member or datastore level setting. The ALTPCB output is saved in a TPIPE hold queue.

This parameter is optional and has no default value. Note that this parameter is ignored for non-IMS Connect clients.

IMS synchronous program switch parameters

The T MEMBER, T PIPE, S MEM, S YN T I M E R, and E X I T parameters are valid for IMS synchronous program switch descriptors (TYPE=IMSTRAN). The following additional parameters are available for descriptors with TYPE=IMSTRAN:

L T E R M O V R

Specifies a logical terminal name used to override the name specified in the I/O PCB of the IMS application program. This parameter is optional.

IMS attempts to get a logical terminal name for the target transaction from the following locations in the following order:

1. From the AIB.
2. From the OTMA destination descriptor.
3. If an LTERM name is not specified in the descriptor or in the AIB, the IMS application terminal symbolic (PSTSYMBOL) is used as the default value.

REPLYCHK=YES | NO

Specifies whether the IMS detects when the target IMS application replies to the I/O PCB. When REPLYCHK=YES is specified and the target application does not reply to the I/O PCB (or issue an ICAL request for synchronous program switch to a third application), IMS gives the return code X'0100' with reason code X'0110' and extended reason code X'0061' instead of a timeout to the ICAL call. This parameter is optional and the default is YES.

Also, if there are multiple responses to the ICAL (redundant messages), the response that is sent as a CM1 message is returned to the application that issued the ICAL call. Other responses that use CM0 are dequeued or rerouted to the late message tpipe.

When REPLYCHK=NO is specified, no check is done to see if the target application replies to the I/O PCB or if it issues a synchronous program switch to another transaction. If there are multiple response messages, the first response (CM1 or CM0) is returned to the application that issued the ICAL call. All other responses are dequeued or rerouted.

SYNCTP=NO | YES

Specifies whether the destination TPIPE for the late messages needs to be created as a synchronized TPIPE. This parameter is optional and the default is NO.

IBM MQ parameters

The TMEMBER, TPIPE, USERID, and EXIT parameters are valid for IBM MQ descriptors, as well as the following additional parameters. The MQRTQ= parameter is required for TYPE=MQSERIES descriptors.

SYNCTP=NO | YES

Specifies whether a SYNC TPIPE must be created for this message. This parameter is optional and the default is NO.

MQPERST=NO | YES

Specifies whether this message is persistent on a SYNC TPIPE. This parameter is optional and the default is NO.

MQCOPYMD=YES | NO

Specifies whether the original input MQMD structure values from the MQ IMS bridge must be copied to this output message. This parameter is optional and the default is YES.

MQREPORT=COPYMTOC | NEWMSGID | PASSCORR | PASSMSGI | NONE

Specifies the MQMD_REPORT value:

COPYMTOC

MQ report option: MQRO_COPY_MSG_ID_TO_CORREL_ID

NEWMSGID

MQ report option: MQRO_NEW_MSG_ID

PASSCORR

MQ report option: MQRO_PASS_CORREL_ID

PASSMSGI

MQ report option: MQRO_PASS_MSG_ID

NONE

MQ report option: MQRO_NONE

This parameter is optional and the default is COPYMTOC.

MQFORMAT=MQIMSVS | MQIMS | MQSTR | NONE

Specifies the MQMD_FORMAT value:

MQIMS

MQ format option: MQFMT_IMS

MQIMSVS

MQ format option: MQFMT_IMS_VAR_STRING

NONE

MQ format option: MQFMT_NONE

MQSTR

MQ format option: MQFMT_STRING

This parameter is optional and the default is MQIMSVS.

MQMSGID=0 | mqmd_mqmsgid

Specifies the MQMD_MSGID name. This is a 1- to 24-character value that is passed to the receiving MQ application based on the value of the MQMD_REPORT field. This parameter is optional and the default is 0.

MQCORREL=0 | mqmd_mqcorrelid

Specifies the MQMD_CORRELID name. This is a 1- to 24-character value that is passed to the receiving MQ application based on the value of the MQMD_REPORT field. This parameter is optional and the default is 0.

MQRTQ=mqmd_mqrtq

Specifies the 1- to 48-character MQMD_REPLYTOQ value. This parameter is required when TYPE=MQSERIES is specified for the descriptor.

MQRTQMGR=mqmd_replytoqmgr

Specifies the 1- to 48-character MQMD_REPLYTOQMGR value. This value is the queue manager name. This parameter is optional and if not specified then MQSeries® will use the local QManager.

MQAPPLID=mqmd_applidentitydata

Specifies the 1- to 32-character MQMD_APPLIDENTITYDATA value. You can use this value to pass data to the receiving MQ application. This parameter is optional and the default is blanks.

MQRTF=mq_replytoformat

Specifies the 1- to 8-character ReplyToFormat value. This value is not part of the MQMD data structure, but it is submitted to MQ by OTMA at the same time. IBM MQ uses the value of this parameter for the MQIIH_ReplyToFormat field when the value of MQMD_FORMAT is MQIMS. This parameter is optional and the default is binary zeroes.

Example

The following example shows several OTMA destination descriptors.

```
D OTMACL99 TYPE=IMSCON TMEMBER=HWS1 TPIPE=HWS1TP01
D OTMACL*  TYPE=IMSCON TMEMBER=HWS2
D PRNTR3A  TYPE=NONOTMA
D SOAPGWAY TYPE=IMSCON TMEMBER=HWS2 TPIPE=HWS2SOAP SYNTIMER=20
D SOAPGWAY ADAPTER=XMLADPTR CONVRTR=XMLCNVTR
```

The first descriptor is a destination descriptor for destination OTMACL99 to route messages to TMEMBER HWS1 and TPIPE HWS1TP01.

The second descriptor is for destinations that match the mask OTMACL*. Messages are routed to IMS Connect TMEMBER HWS2, with a TPIPE of the destination that matches the mask (for example, OTMACL04).

The third descriptor is another destination descriptor for destination PRNTR3A that is routed to IMS.

The last descriptor is a destination descriptor for IMS Enterprise Suite SOAP Gateway, with a destination name of SOAPGWAY. Messages are routed to IMS Connect TMEMBER HWS2 with TPIPE HWS2SOAP, with a timeout value of 0.2 seconds for synchronous callout processing, and then are processed by the specified XML adapter.

IBM MQ example

The following example shows a IBM MQ destination descriptor.

```
D MQALL    TYPE=MQSERIES TMEMBER=VC7 TPIPE=MQMPIPE
D MQALL    USERID=JACK  EXIT=NO
D MQALL    MQRTQMGR=VC7 MQRTQ=OTMA.FROM.IMS
```

```

D MQALL MQREPORT=COPYMTOC MQFORMAT=MQIMSVS MQPERST=YES
D MQALL MQMSGID=MSG456789012345678901234
D MQALL MQCORREL=COR456789012345678901234
D MQALL MQAPPLID=APP45678901234567890123456789012
D MQALL MQRTF=RTF45678 MQCOPYMD=NO

```

Related reference

[CREATE OTMADESC command \(Commands\)](#)

[DELETE OTMADESC command \(Commands\)](#)

[QUERY OTMADESC command \(Commands\)](#)

[UPDATE OTMADESC command \(Commands\)](#)

DFSOTMA descriptor syntax and parameters

Use the optional DFSOTMA descriptor to define global and default attributes, limits, and types of support that apply to all OTMA clients.

The DFSOTMA descriptor is an OTMA type-M descriptor that sets system defaults and global parameters for all OTMA clients that connect to this IMS system.

The DFSOTMA descriptor does not support all of the parameters that you can specify on an OTMA client descriptor. Parameters that are not supported, such as DRU= and T/O=, are ignored if they are specified in the DFSOTMA client descriptor.

The global values that you can specify for all OTMA clients include:

- Message flood protection
- Global tpipe limit for all the OTMA members or clients
- Support for multiple active resume tpipe requests
- Save area prefix allocation limits
- The maximum number of OTMA descriptors
- The maximum number of RACF user IDs that can have cached accessor environment elements (ACEEs) stored in subpool 249.
- Passing the input LTERM override name to IBM Workload Manager
- OTMA default tpipe cleanup or OTMA fast tpipe checkpoint cleanup

Because the DFSOTMA descriptor is a type-M descriptor, when the DFSOTMA descriptor is used, the maximum number of OTMA client descriptors that you can define is one less, because OTMA client descriptors are also type-M descriptors.

The DFSOTMA descriptor is always loaded from the DFSYDTx PROCLIB member regardless of the IMS restart type. There are no checkpoint log records for the DFSOTMA descriptor.

Format

You can use up to 50 lines in the specification of a descriptor. Columns 1 - 18 must be the same for each line. You must delimit all parameters by using a blank space.

The following table shows the format of the DFSOTMA descriptor.

Column	Contents	Description
1	M	The DFSOTMA descriptor uses the same type designator as an OTMA client descriptor.
2	Blank	This field is left blank.

Table 84. Format of the DFSOTMA descriptor (continued)

Column	Contents	Description
3-18	DFSOTMA	The name of the descriptor. The name DFSOTMA defines this descriptor as the OTMA descriptor that sets system defaults and global attributes for all OTMA clients. The name DFSOTMA is required and positional.
19	Blank	This field is left blank.
20-72	DFSOTMA descriptor parameters	Enter the parameters in any order. Separate parameters by using a blank space.
73-80	Sequence numbers	These columns are ignored by IMS.

Parameters

You can specify the following parameters on the DFSOTMA descriptor:

Important: If an invalid parameter is specified on an OTMA client descriptor, IMS rejects the parameter by issuing a DFS2385E error message with the syntax error information. IMS continues processing the rest of the parameters in the client descriptor and takes one of the following actions when the processing completes:

- If **ABEND=YES** is specified in the DFSOTMA descriptor, IMS initialization terminates abnormally with ABEND0078.
- If **ABEND=NO** is specified in the DFSOTMA descriptor, IMS accepts the valid parameters and IMS initialization completes without ABEND 0078.

For more information on the **ABEND=** parameter, see DFSOTMA descriptor syntax and parameters.

ABEND=NO|YES

Specifies IMS initialization terminates abnormally when an invalid parameter is specified in an OTMA client descriptor or a DFSOTMA descriptor.

This parameter is an OTMA global attribute and cannot be specified in an OTMA client descriptor. It has no effect on OTMA destination descriptors. The default value is NO.

NO

Specifies that OTMA accepts the valid parameters in the client descriptor or the DFSOTMA descriptor. Any invalid parameters specified are rejected with a DFS2385E error message.

YES

Specifies that the IMS system abends with ABEND0078 when an invalid parameter is specified in an OTMA client descriptor or a DFSOTMA descriptor.

ACEUSR=

A 1- to 6-digit decimal integer in the range 0 - 999,999 that defines the maximum number of RACF user IDs that can have cached accessor environment elements (ACEEs) stored in subpool 249.

If you specify a value for the **ACEUSR=** parameter but you explicitly specify **TOACEE=NO**, the ACEE flood control function is disabled and the **ACEUSR=** parameter is ignored.

If you specify a value for the **ACEUSR=** parameter but you do not specify the **TOACEE=** parameter, the value of **TOACEE=** is automatically set to YES and the value that you specify for the **ACEUSR=** parameter is used.

If OTMA caches ACEEs but you do not specify the **ACEUSR=** parameter, OTMA uses the default value of 30,000 for **ACEUSR=**.

If you specify both **ACEUSR=0** and **TOACEE=YES**, OTMA uses the default value of 30,000 for **ACEUSR=**.

DDESCMAX

A 3- to 4-digit decimal integer from 510 to 4095 that defines the maximum number of destination (type-D) descriptors that can be defined in the IMS system, either by the **CREATE OTMADESC** command or by coding them in the DFSYDTx member of the IMS PROCLIB data set.

Any value less than 510 is set to 510. Any 4-digit value greater than 4095 is set to 4095. The default value is 510.

This parameter is only valid for the DFSOTMA descriptor.

Destination descriptors are stored in the extended common storage area (ECSA). The more destination descriptors that are defined, the more ECSA storage is used.

DSAP

Specifies the system default setting for the minimum allocation of save area prefixes (SAPs) for OTMA clients that do not specify a value in the OTMA client descriptor.

Valid values are 18 - 500. The default value is 18.

DSAPMAX

Specifies the system default setting for the maximum allowable number of SAPs that an OTMA client can have allocated at the same time. The DFSOTMA **DSAPMAX** value applies only to those OTMA clients that do not specify a **DSAPMAX** value in the OTMA client descriptor.

Valid values are 18 - 500. If the value that is specified on the **DSAPMAX** parameter is less than the value of the **DSAP** parameter, a value of 500 is used.

ENDCONV=

A 1- to 4-digit decimal integer in the range 0 - 7200 that defines the timeout value in seconds for an idle OTMA conversational transaction. If the conversational transaction remains idle for the specified number of seconds after the prior iteration of the conversational transaction completes, OTMA ends the transaction and releases IMS resources that were allocated for the transaction.

If this parameter is not specified, the default value is 3600 seconds, which is 1 hour.

If 0 is specified for this parameter, OTMA deactivates the timeout function for conversational transactions.

If a value in the range 1 - 119 is specified, OTMA automatically sets the value to 120.

If a 4-digit value greater than 7200 is specified, OTMA automatically sets the value to 7200.

If a 5-digit value is specified, the number will be rejected.

FASTTPCU=NO|YES

Specifies whether the OTMA fast transaction pipe checkpoint cleanup (FASTTPCU) function is enabled. The default value is NO.

NO

Specifies that the OTMA FASTTPCU function is disabled. OTMA transaction pipes (tpipe) in an IMS system will be cleaned up after they keep being idle for three consecutive checkpoints.

YES

Specifies that the OTMA FASTTPCU function is enabled. OTMA tpipes in an IMS system will be cleaned up after being idle for two consecutive checkpoints instead of three consecutive checkpoints.

The back-end IMS system in a shared queues environment inherits the FASTTPCU setting from the front-end IMS system for any OTMA tpipes generated for work from the front-end IMS system, regardless of the FASTTPCU setting in the back-end IMS system.

Important: While you can clean up inactive tpipes faster than before with the FASTTPCU function, IMS's performance may remain unchanged.

ICALRTP=YES|NO

Specifies whether IMS rejects the ICAL call when there is no outstanding **RESUME TPIPE** request. The default value is YES.

YES

Specifies that IMS rejects the ICAL call if there is no outstanding **RESUME TPIPE** request. This prevents the IMS application program that issues the ICAL call from getting an ICAL timeout error due to a missing **RESUME TPIPE** request.

NO

Specifies that IMS does not reject the ICAL call if there is no outstanding **RESUME TPIPE** request. The IMS application program that issues the ICAL call waits for an active **RESUME TPIPE** request until the ICAL call times out.

INPT=

A decimal integer from 0 - 99999 that defines the maximum number of input messages from all OTMA clients or members that can be waiting to be processed at the same time. If you specify a value of 0, OTMA deactivates the input message flood detection. If the value is 1 - 0200, it is treated as 0200.

When an OTMA client sends a transaction to IMS, OTMA internally creates a transaction instance control block (TIB) in storage to track each active input message. Activating a global flood threshold protects IMS from getting storage-related abends as a result of too many TIBs in the system.

If the number of TIBs reaches 80% of the global flood limit, IMS issues the DFS3428W warning message to the MTO and system console, and sends OTMA protocol messages that reflect a warning status to all the OTMA member clients. This message is issued every 5% thereafter until the global message limit is reached.

When global flood control is active and the global flood limit is reached, IMS takes the following actions:

- OTMA rejects all new input transactions from all the members, including synchronous program switch requests from the internal OTMA member DFSYICAL
- The status of the OTMA server member is set to "SERVER-FLOOD". The status can be displayed by issuing the **/DISPLAY OTMA**.
- IMS issues a DFS3429E error message to the console and MTO
- OTMA sends an "unavailable for work" protocol message (command type X'3C') to all the OTMA members. OTMA members can then choose to take corrective action, such as rerouting new transaction requests to another IMS system.

This global flood status is relieved when the input messages in the system are processed and the number of total TIBs in the system is reduced to 50% or less of the global limit. A DFS0793I is sent to IMS MTO and system console along with OTMA protocol messages that reflect a good status to all the OTMA members.

If no global limit is specified in the DFSOTMA descriptor, any client descriptors, or the **/START TMEMBER ALL INPUT** command, the default global flood processing takes place in the system, and the default global flood limit is set to 10000 to protect the system. The default OTMA global flood actions include:

- Warning message DFS3428W starting at the 80% level of the flood limit and every 5% thereafter.
- Warning message DFS4388W when 100% level is reached.
- Relief message DFS0793I when the flood is relieved and back to 50% level.

The OTMA protocol message that reflects a warning or good status is sent to all the OTMA members.

LIMITRTP

For any OTMA client that does not make its own LIMITRTP specification, specifies the default maximum number of active **RESUME TPIPE** requests that the tpipes of the OTMA client can support. If **MULTIRTP=YES** is not already specified, specifying a value on **LIMITRTP** parameter enables support for multiple active **RESUME TPIPE** requests for any client that does not specify the **MULTIRTP** parameter itself.

Valid values are a 1- to 4-digit decimal integer between 10 and 4095. IMS treats values between 0 and 9 as 10. IMS treats any 4-digit decimal number greater than 4095 as 4095. The default value for **LIMITRTP** parameter is 100.

When the maximum number of active **RESUME TPIPE** requests is reached, any additional **RESUME TPIPE** requests that are received are queued and become active after a currently active request ends.

For the super member function, the **LIMITRTP** value of the first OTMA client that connects to the IMS defines the **LIMITRTP** value of the super member.

Using OTMA type-M descriptors is the only way to specify or change the **LIMITRTP** value. OTMA clients cannot set or change the **LIMITRTP** value in a client bid protocol message.

LITETP=NO|YES

Specifies whether the OTMA lightweight tpipe function is enabled.

NO

Specifies that the OTMA lightweight tpipe function is disabled. This is the default for an IMS cold start.

YES

Specifies that the OTMA lightweight tpipe function is enabled. When this function is enabled, less storage is used when a tpipe is created in a shared queues back-end IMS system to process front-end input transactions. Specifying **LITETP=YES** enables IMS to support more tpipes.

Message DFS7411I is issued on IMS initialization to indicate that this function is enabled.

Because a lightweight tpipe requires less storage than a regular tpipe, a weighting factor is used on back-end tpipes when calculating the tpipe count for tpipe flood control. The weighting factor is the percentage of the lightweight tpipe storage size relative to the regular tpipe storage size, which is usually 28%.

The adjusted tpipe count is calculated as follows:

A: the number of front-end tpipes (total tpipes - back-end tpipes)

B: the number of back-end tpipes

W: the weighting factor

adjusted tpipe count=A+(B*W)

When the DFSOTMA **MAXTP=** parameter is specified, if the **LITETP=** parameter is enabled, IMS monitors if the number of tpipes reaches the maximum allowable number by using the adjusted tpipe count instead of the total tpipe count, which consists of the number of front-end tpipes plus the number of back-end tpipes. If the **LITETP=** parameter is disabled, IMS keeps using the total tpipe count for flood control.

The value of the **LITETP=** parameter value is saved at check point. On IMS restart, IMS may use one of the following values for the **LITETP=** parameter:

- If the **LITETP=** parameter is specified, then IMS uses the new value.
- If the **LITETP=** parameter is not specified, or the DFSYDTx member does not exist, then IMS restores and uses the previous saved value.

MAXTP=

A 1- to 6-digit decimal integer from 0 - 999999 that defines the maximum total number of tpipes in an IMS system for all OTMA clients. If a value of 0 is specified, which is the default, OTMA stops monitoring the creation of the tpipes. If the value is between 1 and 200, it is treated as 200. Any number over 999999 is rejected.

Before the DFSOTMA **MAXTP** value is reached, IMS issues message DFS4515W as a warning when the number of tpipes in the IMS system reaches a threshold through a percentage of the maximum number that is either 80% or a user-specified percentage through the **MAXTPWN** parameter. OTMA also issues a protocol message to all OTMA clients. After the threshold is reached, OTMA continues creating new tpipes until the number of tpipes reaches the maximum number of tpipes allowed as defined by the **MAXTP** value.

If the total number of tpipes in the IMS system reaches the number that is specified on the DFSOTMA **MAXTP** parameter, OTMA rejects all new tpipe creation requests from all OTMA members with a NAK with sense code X'29'. IMS sends DFS4516E error message to the system console and the MTO,

and notifies all OTMA clients with an OTMA protocol message. The /DISPLAY OTMA command shows "MAX TPIPE" in the user status of the OTMA server.

When the number of tpipes for all members falls to 50% or a user-specified percentage of the global tpipe warning threshold through the **MAXTPRL** parameter, IMS issues message DFS4517I to the IMS system console and the master terminal operator (MTO). OTMA also notifies all OTMA clients of the improved status with a protocol message.

If **MAXTP** parameter is not specified in the DFSOTMA descriptor and one or more OTMA members define a **MAXTP** value, the highest **MAXTP** value that is specified among the OTMA clients defines only a global warning threshold for the total number of tpipes in the system for all OTMA clients. When this global warning threshold is reached, IMS does not prevent the creation of new tpipes, but merely issues message DFS4385W to the MTO and system console. OTMA also warns all OTMA clients with a server state protocol message. When the global tpipe count falls to 80% of the global tpipe warning threshold or below, IMS issues message DFS4386I to the MTO and system console. OTMA also notifies all OTMA clients with another protocol message.

The /DISPLAY OTMA command and the /DISPLAY TMEMBER command can display the current numbers of tpipes and the DFSOTMA **MAXTP** value.

Note:

If **LITETP=**YES, the adjusted tpipe count is used instead of the total tpipe count, which consists of the number of front-end tpipes plus the number of back-end tpipes, to check whether the IMS system reached the maximum tpipe limit.

See the description of the **LITETP=** parameter in this topic for the calculation of the adjusted tpipe count.

MAXTPBE=YES | NO

Defines the IMS system default for **MAXTPBE** parameter. The DFSOTMA **MAXTPBE** value is used by OTMA clients that do not specify **MAXTPBE** parameter themselves.

MAXTPBE parameter determines whether the number of tpipes in the IMS system must be monitored when this IMS is a shared queues back-end system that processes front-end initiated OTMA input transactions at the application GU time. **MAXTPBE** parameter applies only when **MAXTP** parameter is specified. **MAXTPBE** is ignored if **MAXTP** value is not specified. The default is YES.

MAXTPRL=

Specifies the relief level for tpipe flood conditions as a percentage of the tpipe count against the DFSOTMA **MAXTP** value. The DFSOTMA **MAXTPRL** parameter sets the default for OTMA clients that do not specify a **MAXTPRL** value themselves.

Valid values are 50 -95. Values specified that are below 50 are set to 50. Values over 95 are set to 95.

The default relief level is 50% of the tpipe **MAXTP** value.

If **LITETP=**YES, the relief level is measured as a percentage of the DFSOTMA **MAXTP** value by using the adjusted tpipe count instead of the regular total tpipe count. See the **LITETP=** parameter in this topic for the calculation of the adjusted tpipe count.

MAXTPWN=

Specifies the warning level for the tpipe flood conditions as a percentage of the DFSOTMA **MAXTP** value. The DFSOTMA **MAXTPWN** parameter sets the default for OTMA clients that do not specify a **MAXTP** value.

Valid values are 50 - 95. Values specified that are below 50 are set to 50. Values over 95 are set to 95.

The default warning level is 80% of the tpipe **MAXTP** value.

MDESCMAX

A 3- to 4-digit decimal integer from 255 to 4095 that defines the maximum number of client (type-M) descriptors that can be defined in the DFSYDTx member of the IMS PROCLIB data set.

Any value less than 255 is set to 255. Any 4-digit value greater than 4095 is set to 4095. The default value is 255.

When MDESCMAX parameter is specified, the DFSOTMA descriptor must be one of the first 255 type-M descriptors that are defined in the DFSYDTx PROCLIB member.

This parameter is only valid for the DFSOTMA descriptor.

Client descriptors are stored in the extended common storage area (ECSA). The more client descriptors that are defined, the more ECSA storage is used.

MULTIRTP=YES | NO

Specifies the OTMA default for tpipe support of multiple active **RESUME TPIPE** requests. The DFSOTMA **MULTIRTP** specification applies only to OTMA clients that do not have a **MULTIRTP** value specified in their OTMA client descriptor.

When **MULTIRTP=YES** is specified, by default the tpipes that are created for OTMA clients that connect to this IMS system support multiple active resume tpipe requests. Commit-then-send (CM0) output messages or callout request messages from IMS application programs can be retrieved by multiple client instances in parallel.

When **MULTIRTP=NO** is specified, by default, the tpipes that are created for OTMA clients that connect to this IMS system support only a single active resume tpipe request at a time. IMS commit-then-send (CM0) messages or callout messages are delivered to client one message at a time. Any subsequent resume TPIPE requests that are received while the first one is still active are queued.

The DFSOTMA **MULTIRTP** value can be overridden by specifying the **MULTIRTP** value in the OTMA client descriptors.

TOACEE=NO|YES

Specifies whether OTMA accessor environment element (ACEE) flood control is enabled.

The default value is NO.

If you do not specify this parameter but you specify a value for the **ACEEUSR=** parameter, IMS automatically sets the value of the **TOACEE=** parameter to YES.

NO

Specifies that OTMA ACEE flood control is disabled.

YES

Specifies that OTMA ACEE flood control is enabled. If you specify **TOACEE=YES**, the value that is specified for the **ACEEUSR=** parameter is used by OTMA to limit the number of RACF user IDs that can have cached ACEEs stored in subpool 249.

After you enable OTMA ACEE flood control, OTMA also checks the expiration values of the least recently used ACEEs every 2 minutes. The ACEEs that expired are cleaned up.

TODUMP=NO|YES|U243

Specifies whether the pseudo ABENDU0243 is needed at application GU time for one of the following reasons:

- An OTMA transaction expired.
- An OTMA input transaction that requires a new tpipe is rejected when the tpipe flood limit that is defined in the INPT parameter has been reached.

This parameter is optional and defaults to **TODUMP=NO**.

If the **TODUMP=** parameter is also specified in an OTMA client descriptor, it overrides the value of the DFSOTMA **TODUMP=** parameter for that OTMA client.

If you use IMS shared queues and the **TODUMP=** parameter is specified, the parameter needs to be set in the OTMA client descriptor or DFSOTMA descriptor in the front-end IMS system.

You can specify one of the following values for this parameter:

NO

If NO is specified, the IMS system discards the affected transaction without the ABENDU0243 to save CPU cycles. Because pseudo ABENDU0243 is not issued for each affected transaction at GU

time, no additional IMS type X'56' log records are written. However, IMS writes a type X'67D0' diagnostic information log record for each affected transaction at GU time.

YES

If YES is specified, a pseudo ABENDU0243 with message DFS554A and symptom dump is generated at the GU time for each expired or rejected OTMA transaction. If you specify YES, the console might become flooded and the IMS system might require more CPU cycles if many transactions are expired or rejected.

U243

If U243 is specified, a pseudo ABENDU243 is generated without message DFS554A and without symptom dump for each affected transaction at GU time. To identify the transactions that pseudo ABENDU243 is issued for, see the IMS type X'56' log record.

WLMLTRM=NO|YES

Specifies whether OTMA needs to pass the input logical terminal (LTERM) override name to IBM Workload Manager to invoke input transactions.

The default value is NO.

NO

Specifies that OTMA passes the input tpipe name to IBM Workload Manager for the input transactions.

YES

Specifies that OTMA passes the input LTERM name to IBM Workload Manager for the input transactions.

Example

The following example shows a DFSOTMA descriptor.

```
M DFSOTMA          INPT=50000 MAXTP=5000 MAXTPRL=60 MULTIRTP=YES
```

DSPBIxxx member of the IMS PROCLIB data set

Use the DBRC initialization member of the IMS PROCLIB data set (DSPBIxxx) to specify parameters that initialize the DBRC address space. Some parameters in this member of the IMS PROCLIB data set can be overridden with DBRC execution parameters.

You can use the IMS Syntax Checker to modify this member of the IMS PROCLIB data set.

Syntax

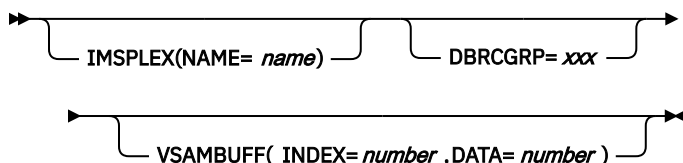

Usage

A DSPBIxxx member consists of one or more fixed-length character records (the configuration data set can be of any LRECL greater than eight, but it must be fixed record format). The rightmost-eight columns are ignored but can be used for sequence numbers or any other notation. Keyword parameters can be coded in the remaining columns in free format, and can contain leading and trailing blanks. You can specify multiple keywords in each record; use commas or spaces to delimit keywords. Statements that begin with a "*" or "#" in column 1 are comment lines and are ignored. Additionally, comments can be included anywhere within a statement by enclosing them between "/* " and "*/", for example, /* PROCLIB comments */. Values coded in this member of the IMS PROCLIB data set are case sensitive. In general, you should use uppercase for all parameters.

BPE considerations

Use the BPE user exit list member of the IMS PROCLIB data set to define DBRC user exits to BPE. The member is specified on the EXITMBR= parameter in the BPE configuration parameter member of the IMS PROCLIB data set.

A sample DBRC BPE user exit list member of the IMS PROCLIB data set is shown in the following example.

```
/******  
/* DBRC USER EXIT LIST PROCLIB MEMBER */  
/******  
#-----#  
# DEFINE 1 RECON I/O EXIT: ZDBRCI00 #  
# WITH AN ABEND LIMIT OF 8. #  
#-----#  
EXITDEF (TYPE=RECONIO, EXITS=(ZDBRCI00), ABLIM=8, COMP=DBRC)  
#-----#  
# DEFINE 1 DBRC SECURITY EXIT: ZDBRCSE0 #  
#-----#  
EXITDEF (TYPE=SECURITY, EXITS=(ZDBRCSE0), COMP=DBRC)
```

Parameters

IMSPLEX()

Specifies the IMSplex name used by DBRC for SCI registration. The IMSplex name is passed to the DBRC SCI registration exit routine, DSPSCIX0, if it exists. The sample version of DSPSCIX0 that ships with IMS returns the value that you supply to DBRC as the IMSplex name. This parameter is optional and can be overridden by the IMSPLEX execution parameter. Use DBRC SCI registration exit, DSPSCIX0, to determine the IMSplex name instead of the IMSPLEX parameter. Only one IMSPLEX keyword can be specified. The IMSPLEX keyword must precede the left parenthesis. The IMSPLEX definition parameters follow:

NAME=

A 1- to 5-character user-specified identifier that is concatenated to 'CSL' to create the cross-system coupling facility (z/OS cross-system coupling facility) CSL IMSPLEX group name. The value specified here must match the IMSPLEX NAME= value specified in the SCI startup procedure. All DBRC instances in the same IMSplex group that are sharing either databases or message queues must specify the same identifier.

DBRCGRP=

Specifies the three-character DBRC group ID, left-justified and padded with blanks, if necessary. The DBRC group ID is passed to the DBRC SCI registration exit routine, DSPSCIX0 if it exists. The sample version of DSPSCIX0 that ships with IMS returns the value that you supply to DBRC as the DBRC group ID. This parameter is optional and can be overridden by the DBRCGRP execution parameter.

Recommendation: Use the DBRC SCI registration exit, DSPSCIX0, to determine the DBRC group ID instead of the DBRCGRP parameter.

VSAMBUFF()

Specifies the maximum number of index and data buffers to be assigned to the VSAM local shared resource (LSR) pool. Only one VSAMBUFF keyword can be specified. The VSAMBUFF keyword must precede the left parenthesis. The VSAMBUFF definition parameters include:

INDEX=

Specifies the number of index buffers to be used. The valid range is 4 to 32 767. The default is 60.

DATA=

Specifies the number of data buffers to be used. The valid range is 4 to 32 767. The default is 120.

Examples

A sample DBRC initialization member of the IMS PROCLIB data set is shown in the following example. The sample, called DSPBI000, is provided as part of the IMS PROCLIB data set.

```
/******  
/* DBRC INITIALIZATION PROCLIB MEMBER */
```

```
/*  
VSAMBUFF(INDEX=60,DATA=120) /* Set number of #VSAM LSR buffs*/
```

Related concepts

“IMS Syntax Checker” on page 381

The Syntax Checker is an ISPF application that helps you define, verify, and validate parameters and their values in the members of the IMS PROCLIB data set. Use the IMS Syntax Checker to avoid typographical and syntactical errors when modifying the parameter values for the IMS PROCLIB data set members.

FRPCFG member of the IMS PROCLIB data set

Use the FRPCFG member of the IMS PROCLIB data set to define the Repository Server (RS) configuration parameters relating to performance, communications, and security. FRPCFG also identifies the names of the RS catalog repository data sets.

When the RS starts, it processes two configuration members: FRPCFG and the BPE configuration member.

You can use any name for the FRPCFG member. The name must be 8 characters long.

Make sure that you specify the same member name in the FRPCFG=*member_name* parameter in the RS startup JCL.

Environments

The FRPCFG member of the IMS PROCLIB data set is used by the RS address space that is started to manage IMS repositories, such as the IMSRSC repository.

Syntax

You can use the IMS Syntax Checker to modify this member of the IMS PROCLIB data set.

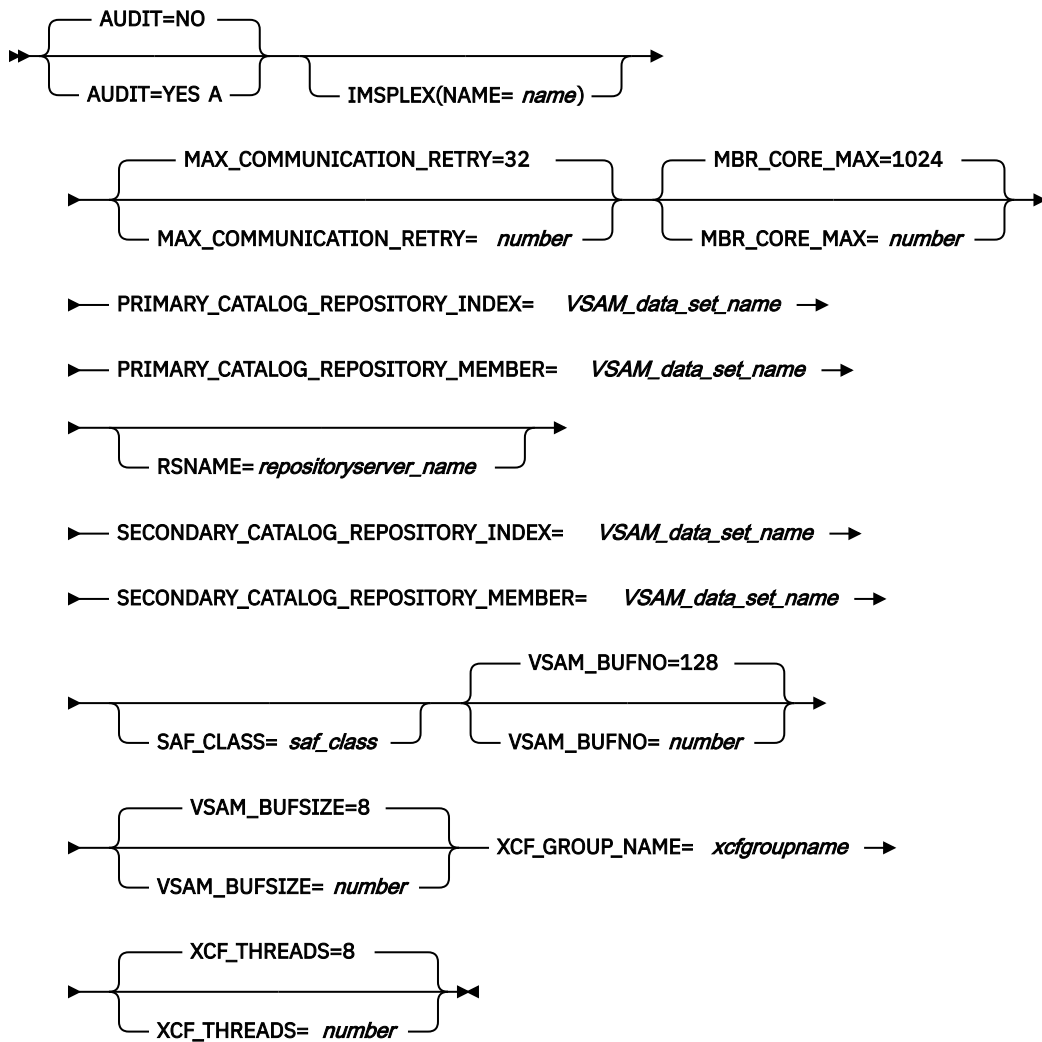

A

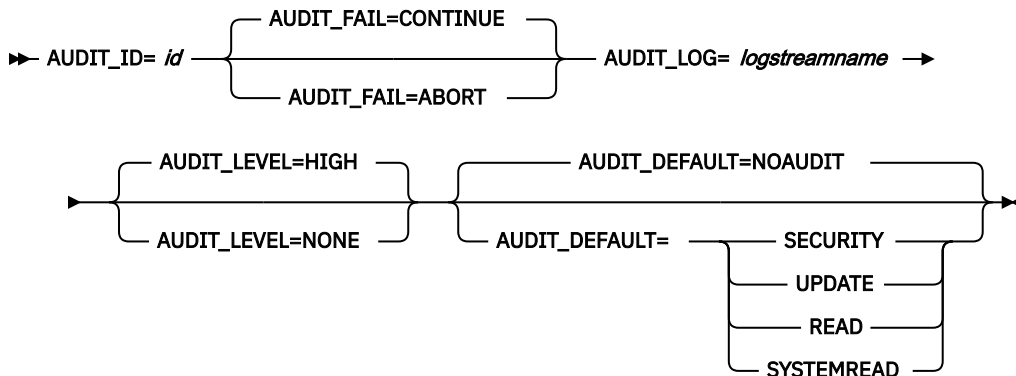

Parameters

AUDIT=NO | YES

This keyword is optional. Specifies whether auditing is enabled.

AUDIT=NO

Auditing is not enabled. Any other AUDIT LOG parameters that are specified are ignored. This is the default.

AUDIT=YES

Enables auditing. If AUDIT=YES, AUDIT_ID and AUDIT_LOG are required.

Y and N are not valid values for this keyword.

AUDIT_ID=id

This keyword is required if AUDIT=YES. *id* is a unique number from 160 to 255 that is placed in the prefix of the log record to identify an audit source. The number is not meaningful. It only identifies audit records that are generated during this RS session so that they can be distinguished from other sources in the log stream.

AUDIT_FAIL=CONTINUE | ABORT

This keyword is optional. Determines whether the RS continues to start or aborts if auditing cannot be established because the log stream is unavailable. After the RS has started, this setting determines what happens if a client audit request is unsuccessful.

CONTINUE

The client request continues as if the audit request was successful. This is the default.

ABORT

The client request fails if the audit record cannot be written.

AUDIT_LOG=logstreamname

This keyword is required if AUDIT=YES. The name of the z/OS log stream to use for the audit records.

AUDIT_LEVEL=HIGH | NONE

This keyword is optional. Determines whether audit records are written to the log. You can change the audit level dynamically by using the command **F reposeservername ,AUDIT**.

HIGH

Audit records are written to the log. This is the default.

NONE

Audit records are not written to the log.

AUDIT_DEFAULT=NOAUDIT | SECURITY | UPDATE | READ | SYSTEMREAD

This is an optional keyword. Determines the default level of auditing of member access during a client member session. This access level applies to members of a given repository for which no audit access rule is set.

NOAUDIT

No auditing of member access. This the default.

SECURITY

Audit security failures only.

UPDATE

Audit member access with update intent.

READ

Audit member access with read or update intent.

Under an audit access rule of READ, system read requests do not cause a read audit record to be generated.

SYSTEMREAD

Audit member access with system-level read, read, or update intent.

A read request from an authorized client as a part of the update call is identified as a *system read* request.

Under an audit access rule of SYSTEMREAD, all read requests, including system read requests, are audited.

You can override the value for the AUDIT_DEFAULT parameter by setting the AUDITACCESS parameter in the CSLRIxx member of the IMS PROCLIB data set.

IMSPLEX()

This keyword is optional. Specifies definitions for the IMSplex for the RS. Only one IMSPLEX keyword can be specified.

NAME=*name*

A 1- to 5-character identifier that specifies the IMSplex group name. This name defines the IMSplex that the RS will belong to. NAME= is required and no default exists.

The RS concatenates this identifier to CSL to create the IMSplex group name. All Operations Manager (OM), Resource Manager (RM), Structured Call Interface (SCI), IMS, RS and IMSplex members that are in the same IMSplex sharing group, sharing either databases or message queues, must specify the same identifier. The same identifier must also be used for the IMSPLEX= parameter in the CSLSIxxx, CSLOIxxx, CSLRIxxx, and DFSCGxxx (or DFSDFxxx) members of the IMS PROCLIB data set.

When IMSPLEX() is specified, and when RSNAME= is also specified, the RS address space registers to the local SCI using the value for the repository ID (REPOID) created from the RSNAME parameter as the SCI member name. Specifying IMSPLEX() and RSNAME= allows the RS to be shown in the output of the QUERY IMSPLEX command.

Note: Including the RS in the QUERY IMSPLEX output is the only use of SCI made by the RS.

If you specify IMSPLEX (), the RS will be included in the QUERY IMSPLEX output; if you do not, it will not. There is no other impact on RS processing, if you specify IMSPLEX().

Both the master RS and subordinate RS register to SCI if IMSPLEX() is specified in their configuration members and their REPOIDs are unique. Only the master RS issues the CSLSCRDY request, indicating to SCI that it is ready to accept work.

IMSPLEX() requires the SCI address space to be available on the same LPAR as the RS address space. If the local SCI is not available, RS retries the register request two more times after the first register request, with a wait of 6 seconds between each request. At the end of the third register request, if SCI is still not available, the RS issues the FRP0003E message and continues processing without registration to SCI. When SCI is started, RS needs to be restarted to be able to register to SCI.

If the RS address space manages repositories in multiple IMSplexes, you must start the SCI of the IMSplex that you want the RS to belong to.

MAX_COMMUNICATION_RETRY=32 | *number*

This keyword is optional. Specifies the number of times a client-side API process retries a failed communication when the failure is due to insufficient z/OS cross-system coupling facility (XCF) threads. If this limit is exceeded, the client request fails with a reason code indicating that the server is busy. By default, 32 communication retries are used. Valid values range from 1 to 255.

MBR_CORE_MAX=1024 | *number*

This keyword is optional. Specifies the maximum amount, in KB, of incore storage allocated to support an XCF data package. If exceeded, a data space is created. By default, 1024 KB of incore storage is used. Valid values range from 64 to 4096.

PRIMARY_CATALOG_REPOSITORY_INDEX=*VSAM_data_set_name*

This is a required keyword. Specifies the name of the primary repository index data set (RID) of the RS catalog repository. This name must match the name of the data set in the JCL that you use to create RS catalog repository data sets.

If the *VSAM_data_set_name* specified for the parameter extends past column 72 into the next line, and you use the Syntax Checker for the FRPCFG member, the data set name must be enclosed in parentheses () as PRIMARY_CATALOG_REPOSITORY_INDEX=(*VSAM_data_set_name*). The data set name can be specified entirely on the next line enclosed in parentheses (). If the FRPCFG member is generated by the Syntax Checker, the data set name will be generated in parentheses ().

PRIMARY_CATALOG_REPOSITORY_MEMBER=VSAM_data_set_name

This is a required keyword. Specifies the name of the primary repository member data set (RMD) of the RS catalog repository. This name must match the name of the data set in the JCL that you use to create RS catalog repository data sets.

If the *VSAM_data_set_name* specified for the parameter extends past column 72 into the next line, and you use the Syntax Checker for the FRPCFG member, the data set name must be enclosed in parentheses () as PRIMARY_CATALOG_REPOSITORY_MEMBER=(*VSAM_data_set_name*). The data set name can be specified entirely on the next line enclosed in parentheses (). If the FRPCFG member is generated by the Syntax Checker, the data set name will be generated in parentheses ().

RSNAME=repositoryserver_name

This keyword is optional. Specifies the 1- to 6-character name for the RS address space. Specify this parameter either as an execution parameter or in the FRPCFG member of the IMS PROCLIB data set.

This name is used to create the REPOID, which is used in RS processing. The 8-character REPOID is the value for RSNAME followed by the characters RP. Trailing blank spaces in the value for RSNAME are deleted and the REPOID is padded on the right with blank spaces. For example, if RSNAME=ABC then the REPOID is ABCRP with 3 blank spaces on the right.

If RSNAME is specified, the REPOID is appended to the end of all the FRP messages issued by the RS.

If there are multiple RSs and IMSPLEX(NAME=) is specified, the value for RSNAME must be unique for each RS, because SCI requires a unique member name. In this case, the REPOID is the member name used to register with SCI.

SAF_CLASS=saf_class

This is an optional keyword. Specifies the 1- to 8-character SAF security class name, which is used to implement repository and member-level security checking.

If this parameter is specified, *saf_class* must be the name of a defined resource class. If this parameter is omitted, SAF security is not used to restrict access to the RS.

The value must be a left-aligned, 8-byte alphanumeric name with trailing contiguous spaces. The first character must be alphabetic.

SECONDARY_CATALOG_REPOSITORY_INDEX=VSAM_data_set_name

This is a required keyword. Specifies the name of the secondary RID of the RS catalog repository. This name must match the name of the data set in the JCL that you use to create RS catalog repository data sets.

If the *VSAM_data_set_name* specified for the parameter extends past column 72 into the next line, and you use the Syntax Checker for the FRPCFG member, the data set name must be enclosed in parentheses () as SECONDARY_CATALOG_REPOSITORY_INDEX=(*VSAM_data_set_name*). The data set name can be specified entirely on the next line enclosed in parentheses (). If the FRPCFG member is generated by the Syntax Checker, the data set name will be generated in parentheses ().

SECONDARY_CATALOG_REPOSITORY_MEMBER=VSAM_data_set_name

This is a required keyword. Specifies the name of the secondary RMD of the RS catalog repository. This name must match the name of the data set in the JCL that you use to create RS catalog repository data sets.

If the *VSAM_data_set_name* specified for the parameter extends past column 72 into the next line, and you use the Syntax Checker for the FRPCFG member, the data set name must be enclosed in parentheses () as SECONDARY_CATALOG_REPOSITORY_MEMBER=(*VSAM_data_set_name*). The data set name can be specified entirely on the next line enclosed in parentheses (). If the FRPCFG member is generated by the Syntax Checker, the data set name will be generated in parentheses ().

VSAM_BUFNO=128 | number

This keyword is optional. Specifies the number of VSAM buffers in the local shared resource pool used for repository access. All I/O between the RS and the RID and RMD uses a single local shared resource pool. The local shared resource pool is built at server startup using the values of the VSAM_BUFNO and VSAM_BUFSIZE parameters in the RS startup JCL. Valid values range from 3 to 65535. By default, 128 VSAM buffers are used.

VSAM_BUFSIZE=8 | number

This keyword is optional. Specifies the size, in KB, of the VSAM LSR pool buffers used for repository I/O. Enter a value from 8 to 32 that is a multiple of 4. The VSAM buffer size must be at least as large as the largest of the control interval sizes of either the RID or RMD components of any repository data set. By default, 8 KB buffers are used. In most cases, 8 KB is the optimal setting for both VSAM_BUFSIZE and the CONTROLINTERVALSIZE parameter in the RS startup JCL.

XCF_GROUP_NAME=xcfgroupname

This is a required keyword. The name of the XCF group that the server joins. Valid characters are A - Z (uppercase only), 0 - 9, and the following symbols: # \$ @

The value must be 8 characters padded on the right with blanks. For example, if you provide a value with only 4 characters, you must also include 4 blank spaces to the right of it.

XCF_THREADS=8 | number

This keyword is optional. Specifies the number of XCF listener threads available to accept data from clients. Each thread allocates a 32 KB buffer. Valid values range from 4 to 99. By default, 8 XCF threads are used.

Sample FRPCFG member of the IMS PROCLIB data set

A sample FRPCFG member of the IMS PROCLIB data set is shown in the following figure:

```
#SAF_CLASS=FACILITY
MBR_CORE_MAX=1024
VSAM_BUFNO=64
VSAM_BUFSIZE=8
XCF_GROUP_NAME=FRPSPLEX
XCF_THREADS=4
PRIMARY_CATALOG_REPOSITORY_INDEX=IMSTESTS.REPO.CATPRI.RID
PRIMARY_CATALOG_REPOSITORY_MEMBER=IMSTESTS.REPO.CATPRI.RMD
SECONDARY_CATALOG_REPOSITORY_INDEX=IMSTESTS.REPO.CATSEC.RID
SECONDARY_CATALOG_REPOSITORY_MEMBER=IMSTESTS.REPO.CATSEC.RMD
```

Related concepts

[“Overview of the IMSRSC repository” on page 37](#)

A repository is a generalized data storage facility that can be used to store any type of information. The IMS resource definition (IMSRSC) repository is a set of VSAM key sequenced data sets (KSDSs) used for storing information. The IMSRSC repository is a repository to store resource (and descriptor) definitions for IMS databases, transactions, programs, and routing codes. This repository is an alternative to the resource definition data set (RDDS) that is used with the dynamic resource definition (DRD) function.

[Repository Server audit log records \(Diagnosis\)](#)

[How the Repository Server handles z/OS logger errors \(Diagnosis\)](#)

[Managing Repository Server audit log records \(Diagnosis\)](#)

Related tasks

[“Allocating RS catalog repository data sets” on page 161](#)

The Repository Server (RS) catalog repository data sets must be allocated before allocating the IMSRSC repository data sets.

[“Defining the IMSRSC repository” on page 40](#)

Before you can use the IMSRSC repository to store and retrieve resource and descriptor definitions, you must define it. In addition, IMS and the Resource Manager (RM) must have the repository enabled, the Repository Server (RS) must be started and active, and the repository must be started.

[Restricting access to the RS catalog repository and IMSRSC repository \(System Administration\)](#)

[Starting the Repository Server \(Operations and Automation\)](#)

Related reference

[“BPE configuration parameter member of the IMS PROCLIB data set” on page 665](#)

Use the BPE configuration parameter member of the IMS PROCLIB data set to define BPE execution environment settings such as tracing, language, and statistics time interval settings for an address space that is being started.

[F reposervername,AUDIT \(Commands\)](#)

[QUERY IMSPLEX command \(Commands\)](#)

[CSLSCRDY: ready request \(System Programming APIs\)](#)

[FRP messages \(Repository Server\) \(Messages and Codes\)](#)

[“CSLRxxxx member of the IMS PROCLIB data set” on page 719](#)

Use the CSLRxxxx member of the IMS PROCLIB data set to specify parameters that initialize RM.

HWSCFGxx member of the IMS PROCLIB data set

Use the IMS Connect configuration member of the IMS PROCLIB data set, HWSCFGxx, to specify environmental settings for IMS Connect.

IMS Connect uses the information it retrieves from this member of the IMS PROCLIB data set to establish communication with IMS and TCP/IP. You can define several configuration members in the partitioned data set to select from during IMS Connect startup. Specify the member name to use in the HWSCFG= parameter of the IMS Connect startup JCL.

Use uppercase characters to specify the statement and parameter keywords in the IMS Connect configuration member.

You can use the IMS Syntax Checker to modify this member of the IMS PROCLIB data set.

Environments

The HWSCFGxx member of the IMS PROCLIB data set applies to IMS Connect, which runs in its own z/OS address space.

IMS Connect can interface with IMS DB systems that run in the DB/DC and DBCTL environments and with IMS TM systems that run in DB/DC and DCCTL environments.

Usage

The IMS Connect configuration member defines how IMS Connect manages connections and communicates with TCP/IP, Open Transaction Manager (OTMA), IMSplexes, Open Database Manager (ODBM), Multiple Systems Coupling (MSC), security software, and other IMS Connect instances.

A HWSCFGxx member consists of one or more fixed-length character records. The configuration member must be in a data set whose format is fixed block, 80-byte record length. The right-most eight columns are ignored but can be used for sequence numbers or any other notation. Keyword parameters can be coded in the remaining columns in free format, and can contain leading and trailing blanks. You can specify multiple keywords in each record; use commas or spaces to delimit keywords.

Statements that begin with an asterisk (*) or number sign (#) in column 1 are comment lines, which are ignored.

Related concepts

[“IMS Syntax Checker” on page 381](#)

The Syntax Checker is an ISPF application that helps you define, verify, and validate parameters and their values in the members of the IMS PROCLIB data set. Use the IMS Syntax Checker to avoid typographical and syntactical errors when modifying the parameter values for the IMS PROCLIB data set members.

Related tasks

[“Configuring IMS Connect” on page 298](#)

IMS Connect supports communication between one or more TCP/IP clients and IMS systems. You can configure multiple IMS systems on multiple z/OS images within a single sysplex and distribute the client request to the IMS systems (data stores).

Related reference

[Format of user portion of IRM for HWSSMPL0, HWSSMPL1, and user-written message exit routines \(Communications and Connections\)](#)

ADAPTER statement

Use the optional ADAPTER statement to define the characteristics of adapters that are used to convert XML input messages to other application programming languages, such as COBOL or PL/I.

ADAPTER statement syntax

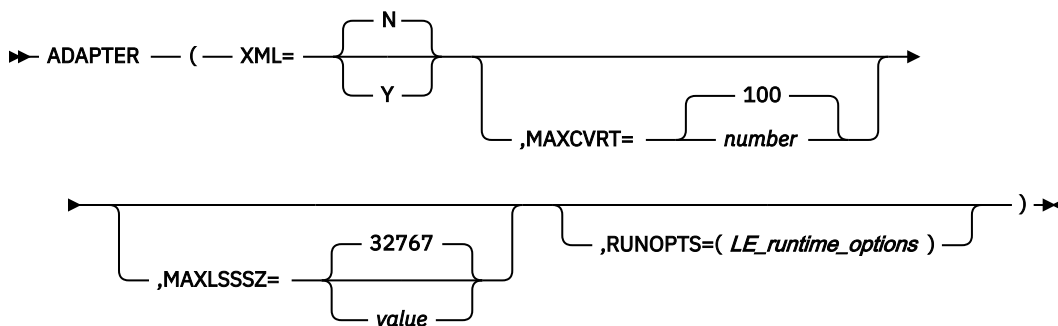

ADAPTER statement parameters

XML

N

XML adapter support should not be enabled. This is the default.

Y

XML adapter support should be enabled. The XML adapter is used to convert the user data in the response message into XML. IMS Connect then sends the output message to the IMS Enterprise Suite SOAP Gateway.

MAXCVRT

Specifies the maximum number of XML converters that this instance of IMS Connect can load concurrently. The minimum value is 100 and the maximum is 2000. The default value is 100. If more than 100 converters are included in the BPE exit list, IMS Connect loads and unloads them from memory as needed. Increasing the value of this parameter allows more converters to be loaded simultaneously, which can reduce the number of times IMS Connect loads the converters from storage. IMS Connect unloads the least recently used XML converter when the maximum is reached.

Restriction: IMS Connect cannot load more than 400 XML converters unless you modify the CSA configuration of the host z/OS LPAR.

MAXLSSSZ

Specifies the maximum language structure segment size. This value is passed to the XML converter when it is called. Valid values are from 5 to 32767. This parameter is optional and defaults to 32767.

RUNOPTS

A 1- to 255-character string field that specifies the Language Environment for z/OS (LE) runtime options to be used to override the IMS Connect default runtime options in support of XML conversion.

This parameter is optional and applies only to the LE environment for XML conversion.

If LE runtime options are not overridden by the RUNOPTS parameter, IMS Connect uses the following default runtime options:

```
ALL31(ON),STACK(, ,ANY),TRAP(ON,SPIE)
```

For more information about the LE runtime options, see [z/OS: Language Environment runtime options](#).

Related tasks

[“Configuring XML conversion support for IMS Connect clients” on page 303](#)

You must configure IMS Connect to convert the input and output messages between an IMS Connect client and an IMS application from XML to a language-specific structure, when the IMS Connect client is IMS Enterprise Suite SOAP Gateway.

DATASTORE statement

The DATASTORE statement defines a connection to the OTMA component of an IMS data store. You can specify multiple DATASTORE statements or omit the DATASTORE statement if this IMS Connect instance does not communicate with OTMA.

IMS Connect does not enforce a limit on the number of DATASTORE statements that you can define. Resource supply and consumption, which vary depending on the configuration of your subsystems, your operating environments, and your workloads, could possibly limit the number of active data store connections that you can use at any one time; however, you are unlikely to hit that limit because IMS Connect control blocks are relatively small and can extend into extended private storage (EPVT). A degradation in performance is likely to occur before any resource-imposed limit is reached.

Another potential limit could be imposed by your z/OS cross-system coupling facility (XCF) configuration. An XCF group has a limit to the number of XCF members that it can support. Each data store connection is treated by XCF as a separate member and an XCF group also contains non-IMS Connect members, such as IMS or IBM MQ. Therefore, the number of XCF members and the number of XCF groups that you define, as well as your XCF workload, could limit the number of data store connections that you can define.

For more information about XCF groups, see *z/OS MVS Setting Up a Sysplex*.

You can also create data store definitions dynamically with the **CREATE IMSCON TYPE(DATASTORE)** type-2 command.

DATASTORE statement syntax

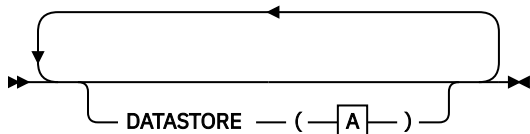

A

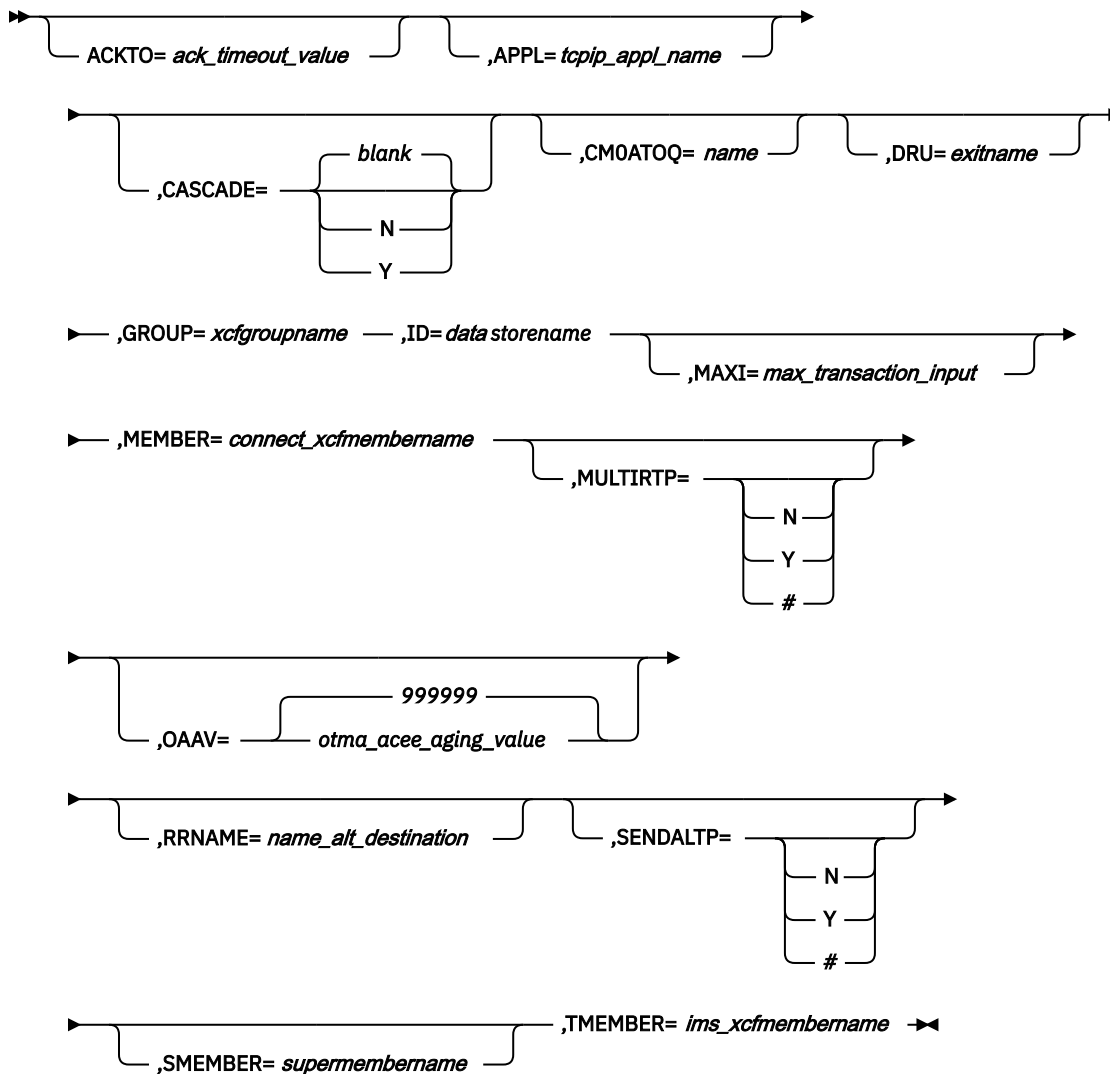

DATASTORE statement parameters

ACKTO=

Specifies a timeout interval for acknowledgements to OTMA for CM0 and CM1 output messages and for IMS-to-IMS transaction messages.

The timeout value can be from 0 to 255 seconds. If the timeout value is 0 or is not specified, the OTMA ACK timeout default value of 120 seconds is set.

For IMS-to-IMS transaction messages, if an acknowledgement is not received by OTMA before the timeout interval expires, OTMA reroutes the transaction message to the default timeout queue, DFS\$ \$TOQ.

APPL=

A 1- to 8-character alphanumeric TCP/IP APPL name defined to RACF in the PTKTDATA statement. This parameter is optional and defaults to blanks. If you are using PassTicket and user message exits, you must specify the APPL on the DATASTORE statement.

The APPL name is passed to RACF whether or not a PassTicket is actually used, and therefore can be used to verify a user's authority to access the datastore.

CASCADE=

For this data store connection only, enables or disables support for the cascading of global, two-phase commit (synclevel=syncpoint) z/OS Resource Recovery Services transactions from IMS TM Resource Adapter via a TCP/IP connection to an IMS TM or IMS DB/DC system that is on a different z/OS image

(LPAR) than IMS Connect. Cascading transactions that are received via a LOCAL option connection is not supported.

The CASCADE parameter applies only to the support for cascading global, RRS transactions between IMS Connect and IMS TM when they are on different z/OS images. The specification of the IMS Connect CASCADE parameter does not affect support between other components or subsystems, such as between IMS subsystems in a shared queues environment.

The CASCADE specification in the definition of a data store connection overrides the value of CASCADE that is in effect for the IMS Connect system.

Until the next restart of IMS Connect, a CASCADE specification made by the **UPDATE IMSCON TYPE (DATASTORE) SET(CASCADE())** command overrides the CASCADE specification on the DATASTORE configuration statement.

blank

If the CASCADE parameter is specified, but the value is left blank, the data store connection inherits the CASCADE value that is in effect for the IMS Connect system configuration. This is equivalent to omitting the CASCADE keyword.

The default is *blank*.

N

Disables support for cascading of global, two-phase commit (synclevel=syncpoint) RRS transactions to an IMS TM or IMS DB/DC system that is running on a different LPAR than IMS Connect. If a synclevel=syncpoint transaction is routed to an IMS system that resides on a different LPAR than IMS Connect, IMS Connect rejects the transaction with return code 4 and reason code NCASCADE.

When support is disabled, you can send a synclevel=syncpoint transaction to IMS on this data store connection only if IMS Connect and IMS reside on the same LPAR.

Y

Enables support for cascading of global, two-phase commit (synclevel=syncpoint) RRS transactions to an IMS TM or IMS DB/DC system that is running on different LPAR than IMS Connect.

IMS Connect detects whether the IMS system is on the same LPAR. If IMS Connect and IMS are running on different LPARs, two-phase commit processing uses cascaded transactions. If IMS Connect and IMS are running on the same LPAR, two-phase commit processing does not use cascaded transactions.

CMOATOQ

1- to 8-character name of the OTMA CMO ACK timeout queue. The value specified here overrides both the OTMA default value of DFS\$\$TOQ and any value set on the HWS statement.

DRU=

A 1- to 8-character alphanumeric DRU keyword. The DRU keyword enables you to specify your own OTMA destination resolution user exit name that is to be passed to OTMA. The DRU exit is required to support asynchronous output to IMS Connect clients. The default is DFSYDRU0, but you can write your own exit.

GROUP=

The z/OS cross-system coupling facility group name for the IMS OTMA. IMS Connect uses this value to join one or more XCF groups. Because IMS Connect and IMS must be in the same XCF group in order to communicate, this group name must match the XCF group name that you define to IMS (*GRNAME*) in the IMS startup JCL (for example, "OTMA=Y,**GRNAME**=&**GROUP**,USERVAR=&MEMBER",...). Each IMS Connect can join any number of groups.

ID=

The data store name, which:

- Consists of alphanumeric character data
- Begins with an alphabetic character

- Has a length between 1 byte and 8 bytes
- Is unique within the IMS Connect configuration member

This ID must match the data store ID that is supplied by the client. For IMS TM Resource Adapter clients, this ID must match the name that is specified in the IMS Interaction Spec for IMS TM Resource Adapter. For non-IMS TM Resource Adapter clients, the ID must match the data store ID that is placed in the IMS Request Message (IRM) that is sent to IMS Connect.

Restriction: The name specified on the ID parameter cannot be the same as a name specified on the TMEMBER parameter of any IMSPLEX statement or substatement in the HWSCFGxx member of the IMS PROCLIB data set.

MAXI=

Specifies the OTMA input message flood control value in the IMS Connect configuration file. The valid range is from 0 to 9999. If you do not specify a value, or specify a value of 0, the OTMA default value of 5000 is used. If you specify a value between 1 and 200, the OTMA minimum value of 200 is used. If you specify a value greater than 9999, the OTMA maximum value of 9999 is used. If you specify a value less than zero or greater than 65 535, abend U3401 is issued.

MEMBER=

The XCF member name that identifies IMS Connect in the XCF group specified by the GROUP parameter. This name is the XCF name that IMS uses to communicate with IMS Connect in that XCF group. This XCF member name for IMS Connect must be unique in the data store definitions for all data stores that are members of the same XCF group.

MULTIRTP=

Specifies the OTMA tpipe support for the parallel processing of multiple RESUME TPIPE requests (MULTIRTP) for the data store connection that is defined by this DATASTORE statement.

The MULTIRTP specification on the DATASTORE statement overrides any MULTIRTP specification on the HWS statement. If the MULTIRTP parameter is not specified on the DATASTORE statement, the DATASTORE connection inherits the MULTIRTP specification from the HWS statement or, if MULTIRTP is not specified on the HWS statement, from OTMA.

N

Specifies that this data store connection requires an OTMA tpipe that supports only a single active RESUME TPIPE request. Output messages on the TPIPE are sent serially.

Y

Specifies that this data store connection requires an OTMA tpipe that supports multiple active RESUME TPIPE requests in parallel. When a tpipe has multiple active RESUME TPIPE requests from multiple DATASTORE connections, OTMA sends the callout or CM0 output messages on the first available connection that is in a receive state.

#

Specifies that MULTIRTP support for this data store connection is determined by the MULTIRTP value in effect for OTMA.

OAAV=

A decimal integer that defines the OTMA accessor environment element (ACEE) aging value, in seconds, for the data store that is specified by the ID keyword. When the OTMA ACEE aging value is reached, OTMA refreshes the ACEE before it processes the next input message received from IMS Connect. Valid values are from 0 to 999999. The default is 999999 seconds. If you specify 0, OTMA uses the default value. If you specify a value from 1 to 300, OTMA uses a value of 300 seconds. OTMA requires a value of at least 300 to enable ACEE refreshes.

RRNAME=

The name of an alternate destination specified in a client reroute request. If this string is not provided, IMS Connect uses HWS\$DEF as the default name. The string is terminated by any blank or invalid character. The reroute name is truncated at any invalid character. This value must be a string of 1- to 8-uppercase alphanumeric (A - Z, 0 - 9) or special characters (@, #, \$), left-aligned, and padded with blanks. IMS Connect translates lowercase characters to uppercase characters.

SENDALTP=

Specifies whether the ALTPCB output that is initiated by a commit-then-send send-receive transaction needs to be sent back to the origin client of this data store. If the **DATASTORE** statement does not specify the **SENDALTP** parameter, the default value is # and the connection inherits the SENDALTP specification from OTMA.

N

Specifies that IMS keeps the ALTPCB output to this data store in a tpipe hold queue. The ALTPCB output can be retrieved by a RESUME TPIPE request.

Y

Specifies that IMS sends the ALTPCB output that is initiated by an IMS Connect commit-then-send send-receive call back to the originating IMS Connect client. If the ALTPCB output cannot be sent, the output is saved in a tpipe hold queue or is removed when asked.

#

Specified that the SENDALTP support for this data store connection is determined by the SENDALTP value in the OTMA client descriptor.

SMEMBER=

1 - 4 alphanumeric character field that specifies the name of the OTMA super member to which this DATASTORE belongs. If specified on the DATASTORE statement, this value overrides the value of the SMEMBER parameter specified on the HWS statement. To disable the value of SMEMBER= specified on DATASTORE, use SMEMBER=####.

TMEMBER=

The XCF member name for IMS that IMS Connect uses in order to communicate with an IMS in its XCF group. This target member name must match the member name IMS uses when it joins the XCF group. The XCF member name for IMS is specified in the IMS startup JCL (for example, "...OTMA=Y,GRNAME=&GROUP, **OTMANM**=&**TMEMBER**,...").

Related reference

[Format of user portion of IRM for HWSSMPL0, HWSSMPL1, and user-written message exit routines \(Communications and Connections\)](#)

[IMS Connect sample OTMA User Data Formatting exit routine \(HWSYDRU0\) \(Exit Routines\)](#)

[OTMA User Data Formatting exit routine \(DFSYDRU0\) \(Exit Routines\)](#)

HWS statement

The HWS statement defines characteristics specific to an instance of IMS Connect.

Specify only one HWS statement for an IMS Connect instance.

HWS statement syntax

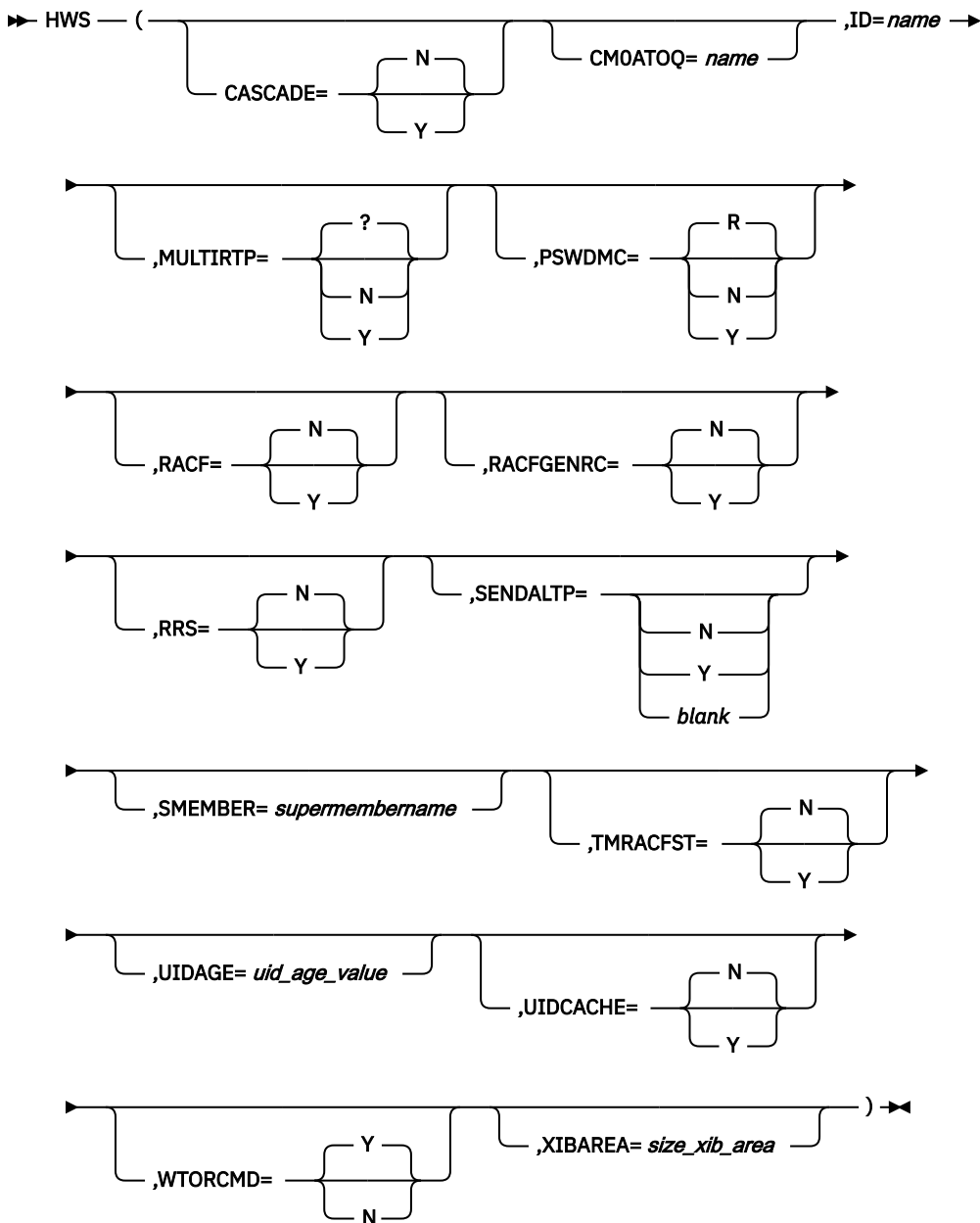

HWS statement parameters

The HWS statement includes the following keyword parameters:

CASCADE=

Defines the IMS Connect default setting for support for cascading global, two-phase commit (synclevel=syncpoint) transactions from IMS TM Resource Adapter via a TCP/IP connection to an IMS TM or IMS DB/DC system that is on a different z/OS image than IMS Connect. Cascading transactions that are received via a LOCAL option connection is not supported.

A CASCADE specification in the definition of a data store connection overrides the CASCADE specification in the IMS Connect system configuration. Any data store connection definition that does not specify a value for CASCADE inherits the CASCADE specification from the IMS Connect system configuration.

Until the next restart of IMS Connect, a CASCADE specification made by the **UPDATE IMSCON TYPE (CONFIG) SET(CASCADE())** command overrides the CASCADE specification on the HWS configuration statement.

The CASCADE parameter applies only to the support for cascading global, RRS transactions between IMS Connect and IMS TM when they are on different z/OS images. The specification of the IMS Connect CASCADE parameter does not affect support between other components or subsystems, such as between IMS subsystems in a shared queues environment.

N

Specifies that, by default, data store connections do not support the cascading of global, two-phase commit (synclevel=syncpoint) transactions to IMS TM and IMS DB/DC systems that are running on a different z/OS image than IMS Connect.

If a synclevel=syncpoint transaction is routed to an IMS system that resides on a different LPAR than IMS Connect, IMS Connect rejects the transaction with return code 4 and reason code NCASCADE.

CASCADE=N is the default.

Y

Specifies that, by default, data store connections support the cascading of global, two-phase commit (synclevel=syncpoint) transactions to IMS TM and IMS DB/DC systems that are running on different z/OS images than IMS Connect.

If IMS Connect and IMS reside on the same LPAR, the transaction is processed without using cascaded transaction support. If IMS Connect and IMS reside on different LPARs, the transaction is processed using cascaded transaction support.

CMOATOQ=

1- to 8-character name of the OTMA CMO ACK timeout queues. The value specified here overrides the OTMA default value of DFS\$\$TOQ and is used for all data stores except those that have their own CMOATOQ value (that is, if you specify a value for CMOATOQ on the DATASTORE statement, it overrides a value for CMOATOQ specified on the HWS statement).

ID=

The IMS Connect name, which:

- Consists of alphanumeric character data
- Begins with an alphabetic character
- Has a length between 1 and 8 characters

MULTIRTP=

Defines the IMS Connect default setting for OTMA tpipe support for parallel processing of the RESUME TPIPE requests from this IMS Connect instance.

A MULTIRTP specification in a DATASTORE statement overrides the MULTIRTP specification in the HWS statement. If a DATASTORE connection definition does not include a MULTIRTP specification, the connection inherits the MULTIRTP specification from the HWS statement.

If MULTIRTP is not specified on either the HWS statement or a DATASTORE statement, the MULTIRTP value in effect in IMS defines the default.

┌

If left blank, or the MULTIRTP parameter is omitted, specifies that, by default, data store connection requests from this IMS Connect instance do not include any specification for MULTIRTP support. MULTIRTP support is determined by either the IMS Connect data store definition or the OTMA client descriptor in the DFSYDTx member of the IMS PROCLIB data set.

N

Specifies that IMS Connect data store connection requests indicate that IMS Connect requires an OTMA TPIPE that supports only a single active resume TPIPE request. Output messages on the TPIPE are sent serially.

Y

Specifies that IMS Connect data store connections require an OTMA TPIPE that can support multiple active resume TPIPE requests in parallel. When a TPIPE has multiple active resume TPIPE requests from multiple data store connections, OTMA sends the callout or CMO output messages on the first available data store connection that is in a receive state.

PSWDMC=

Specifies whether IMS Connect supports mixed-case passwords. Before you enable support for mixed-case passwords, you must configure RACF to support mixed-case passwords.

R

IMS Connect uses whatever is defined for mixed-case passwords in RACF. If mixed-case passwords are active in RACF (which is done through the SETROPTS command) then IMS uses it. If mixed-case passwords are not active in RACF, then IMS Connect uses uppercase passwords. IMS Connect adjusts whenever there are changes to the mixed-case password definition in RACF. R is the default.

N

Disables IMS Connect support for mixed-case passwords. IMS Connect converts any lowercase characters in passwords to uppercase characters.

Y

Enables IMS Connect support for mixed-case passwords.

RACF=

Enables security support by RACF or a similar security product. When RACF=Y, IMS Connect issues a RACROUTE REQUEST=VERIFY call to authenticate the user associated with incoming messages. RACF=N is the default.

For messages from a client application, IMS Connect can use passwords and user IDs for authentication with RACF or RACF PassTickets. The user IDs, passwords, or PassTicket application names can be provided by either the client application or a user exit routine.

For messages from another IMS Connect instance, IMS Connect uses RACF PassTickets to authenticate the user with RACF. After the initial connection request, all subsequent messages received on the socket connection are considered to be from a trusted user and no further authentication is performed.

PassTickets for connections from another IMS Connect instance are generated from the values specified on the USERID and APPL parameters in the RMTIMSCON statement of the IMS Connect instance sending the messages.

PassTickets for IMS Connect client connections that use the Distributed Relational Database Architecture (DRDA) protocol is generated either by the SQL Batch utility or, for other DRDA clients, a service that uses the RACF PassTicket generator algorithm. For DRDA client connections, the application name that is used by IMS Connect on the RACROUTE REQUEST=VERIFY call is obtained from the value of the **APPL=** parameter in the ODACCESS statement.

The RACF= setting can also be changed using the IMS Connect SETRACF command.

RACFGENRC=

Specifies whether a generic return code or message is returned if RACF is used to verify sign-ons to IMS from IMS Connect clients and the user ID or password provided is invalid.

N

IMS Connect returns normal RACF return codes. This is the default value.

Y

IMS Connect returns one of the following generic return codes or message, depending on the IMS Connect client:

- For non-TMRA OTMA clients, RSM_RACFRC=255 for security errors (RSM_RETCODE=8, RSM_RSNCOD=40)
- For TMRA OTMA clients, OMUSR_RACF_RC=255 for security errors (OMUSR_RETCODE=8, OMUSR_RESCODE='SECFAIL')

- For DRDA clients:
 - SECCHKCD(codepoint x'11A4')=x'19'
 - HWSK2865E R=255, RACFRC=255, RACFRSN=0
- For failed password change requests, message HWSC0038E PASSWORD CHANGE ERROR

RRS=

Specifies whether z/OS Resource Recovery Services (RRS) communication is to be enabled or disabled. Set RRS= to yes (Y) or no (N). No is the default.

SENDALTP=

Defines the IMS Connect default setting for getting the ALTPCB output for this IMS Connect instance. The ALTPCB output is initiated by a commit-then-send send-receive transaction.

The SENDALTP specification in a DATASTORE statement overrides the SENDALTP specification in the HWS statement.

If a DATASTORE connection definition does not include a SENDALTP specification, the connection inherits the SENDALTP specification from the HWS statement.

If the SENDALTP parameter is not specified in either the HWS statement or a DATASTORE statement, the SENDALTP value in IMS defines the default.

N

If specified, the ALTPCB output that is initiated by an IMS Connect commit-then-send send-receive transaction is kept in a tpipe hold queue.

Y

If specified, the ALTPCB output that is initiated by an IMS Connect commit-then-send send-receive call is sent back to the origin IMS Connect client. If the ALTPCB output cannot be sent, the output is saved in a tpipe hold queue or is removed when asked.

blank

If the SENDALTP parameter is left blank or omitted, data store connection requests from this IMS Connect instance do not include any specification for the SENDALTP support. The SENDALTP support is determined by either the IMS Connect data store definition or the OTMA client descriptor in the DFSYDTx member of the IMS PROCLIB data set.

SMEMBER=

1- to 4-character field that specifies the name of the OTMA super member to which this instance of IMS Connect belongs. The super member can also be specified on the DATASTORE statement. If a value is specified on both the HWS statement and the DATASTORE statement, the value on the DATASTORE statement takes precedence.

TMRACFST=

Specifies whether RACF statistics are recorded and updated when IMS Connect issues the **RACROUTE REQUEST=VERIFY** call to authenticate connections from an OTMA client to IMS TM.

This parameter is used only if RACF=Y is specified in the HWS statement of the HWSCFGxx configuration member.

N is the default value.

You can change the value of this parameter by using the SET(TMRACFST(ON)) or SET(TMRACFST(OFF)) option on the online IMS Connect command **UPD IMSCON TYPE(CONFIG)**.

Y

RACF statistics are recorded when IMS Connect issues the **RACROUTE REQUEST=VERIFY** call to authenticate connections from an OTMA client to IMS TM. If the logon is successful, a message is also issued. When you specify TMRACFST=Y, the STAT=ASIS parameter is used by IMS Connect on the **RACROUTE REQUEST=VERIFY** call. With STAT=ASIS, the RACF messages and statistics are controlled by the installation's current options on the RACF command **SETROPTS**.

After you enable RACF statistics, the statistics are recorded by RACF no more than once per day to a system management facility (SMF) data set or log stream. The SMF data set or log stream that is used to record the RACF statistics is specified in the RACF configuration.

N

RACF statistics are not recorded when IMS Connect issues the **RACROUTE REQUEST=VERIFY** call to authenticate connections from an OTMA client to IMS TM, and if the logon is successful, no message is issued. When you specify **TMRACFST=N**, the **STAT=NO** parameter is used by IMS Connect on the **RACROUTE REQUEST=VERIFY** call. With **STAT=NO**, the options specified on the RACF command **SETROPTS** are ignored.

For more information about the **STAT=** parameter of the **RACROUTE REQUEST=VERIFY** macro call, see "z/OS Security Server RACROUTE Macro Reference" in the IBM z/OS documentation.

UIDAGE=

Optional parameter that specifies the refresh interval for cached RACF user IDs in seconds. This parameter must be a decimal integer between 0 and 2147483647. If a value less than 300 seconds is specified, the refresh interval is set to 300 seconds. The default value is 2147483647 seconds. This parameter is only valid if the RACF user ID cache is enabled.

UIDCACHE=

Optional parameter that specifies whether IMS Connect caches verified RACF user IDs for reuse. This parameter is valid only if RACF support is enabled. You can also set this parameter with the **SETUIDC** WTOR command, the SET UIDCACHE statement of the UPDATE MEMBER z/OS Modify command, and the **UPDATE IMSCON TYPE(CONFIG) SET(UIDCACHE(ON))** type-2 command.

N

The RACF user ID cache is disabled. N is the default.

Y

The RACF user ID cache is enabled.

WTORCMD

Enables or disables the WTOR command interface for IMS Connect.

Y

Enables the WTOR command interface for IMS Connect and displays the input message for WTOR commands on the system console. Y is the default.

N

Disables the WTOR command interface for IMS Connect. The input message for WTOR commands is not displayed on the system console. When the WTOR command interface is disabled, you can issue commands to IMS Connect by using either the IMS type-2 or the z/OS modify command interfaces.

XIBAREA=

Specifies the number of fullwords allocated for the XIB user area. Both the user initialization exit routine and the user message exit routines can access and modify the XIB user area. The default value is 20; the maximum value is 500. If you do not specify a value for this parameter, or you specify a value outside of the 20 to 500 range, the system uses the default value of 20.

IMSPLEX statement

The optional IMSPLEX statement registers IMS Connect as a member of an IMSplex and enables both IMS type-2 command support for IMS Connect and communications between IMS Connect and other members of the IMSplex.

An IMSplex is built on the IMS Common Service Layer (CSL). Communications in an IMSplex are managed by the CSL Structured Call Interface (SCI). IMS type-2 commands are processed by the CSL Operations Manager (OM). After an IMS Connect instance registers with SCI in an IMSplex, the IMS Connect instance supports IMS type-2 commands and can communicate with other members of the IMSplex.

IMS Connect must be registered with SCI in the IMSplex to provide the following support:

- TCP/IP support for Intersystem Communication (ISC) TCP/IP links between IMS and CICS IBM CICS Transaction Server for z/OS
- TCP/IP support for Multiple Systems Coupling (MSC) links between MSC-enabled IMS systems
- TCP/IP access to IMS databases through the CSL Open Database Manager (ODBM)
- IMS type-2 command support

You can join an IMS Connect instance to more than one IMSplex by specifying multiple IMSPLEX statements.

Certain other configuration statements in the HWSCFGxx member include an IMSPLEX substatement that can be used instead of the IMSPLEX statement. The IMSPLEX substatements allow IMS Connect to join an IMSplex for a specific purpose. The following configuration statements include an IMSPLEX substatement:

- The ISC statement for ISC support
- The MSC statement for MSC support
- The ODACCESS statement for communications with CSL ODBM

Note: An IMS Connect instance can register only a single name in an IMSplex. If the IMSPLEX statement and the IMSPLEX parameter on another configuration statement in the HWSCFGxx member of the IMS PROCLIB data set both specify the same IMSplex name on TMEMBER parameter, they must also specify the same IMS Connect name on the MEMBER parameter.

IMSPLEX statement syntax

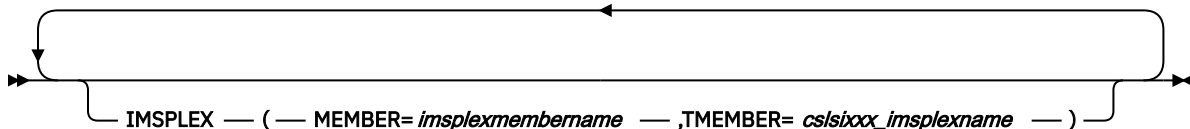

IMSPLEX statement parameters

MEMBER=

A 1- to 8-character alphanumeric name that identifies IMS Connect in the IMSplex that is specified on the TMEMBER parameter of this IMSPLEX statement. The name must start with an alphabetic character. IMS Connect registers this name with SCI. SCI uses the name to manage communications between IMS Connect and the other members of the IMSplex.

TMEMBER=

The name of the IMSplex that IMS Connect is joining, as specified on the IMSPLEX(NAME=) statement of the CSLSIxxx member of the IMS PROCLIB data set of the SCI instance that is managing communications between IMS Connect and the IMSplex.

Restriction: The name specified on the TMEMBER parameter cannot be the same as the name specified on the ID parameter of any DATASTORE statement or substatement in the HWSCFGxx member of the IMS PROCLIB data set.

ISC statement

The ISC statement, in combination with a RMTICIS statement and the CICSPOINT keyword on the TCPIP statement, defines to IMS Connect an Intersystem Communication (ISC) link between a local IMS system and a remote IBM CICS Transaction Server for z/OS subsystem.

The ISC statement identifies the following required attributes of an ISC link:

- The IDs of the partner IMS and CICS subsystems that use the link
- The node name of the link
- The port on which IMS Connect receives transactions and reply data from CICS

- The RMTCICS statement that defines additional attributes of the ISC link, including the host name of the CICS subsystem

The required attributes that are defined by the RMTCICS statement include the host name and port of the partner CICS subsystem.

IMS Connect establishes two socket connections for each ISC parallel session: a *send socket* and a *receive socket*.

The send socket is used to send transactions and reply data to CICS via the remote CICS port that is defined on the RMTCICS statement. IMS Connect creates the send sockets when the ISC parallel session opens. IMS Connect assigns a random client name to the send socket with the three-character prefix ISC. The TCP/IP stack assigns the port number.

The receive socket is used to receive transactions, replies, and commands from CICS. Again, the receive sockets are created when the parallel session is opened. IMS Connect assigns a random client name that starts with ISC. The port number of the receive socket is defined by the CICSPOINT keyword on the ISC statement. The port that CICS uses to send the data is assigned by the TCP/IP stack that the CICS subsystem uses.

ISC statement syntax

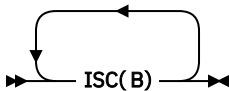

B

►► ID=iscstmid — ,NODE= nodename — ,LCLIMS= local_IMS_ID →

┌──┐
 IMSPLEX=(MEMBER= icon_imsplex_name ,TMEMBER= imsplex_sci_name)

┌──────────────────────────────────┐
 ,RMTCICS= rmt_cics — ,CICSPOINT= portid — ,CICSAPPL= cicsapplid →

┌──────────────────────────────────┐
 ,CICSNETID= cicsnetid ──────────┐

ISC statement parameters

CICSAPPL=

For an ISC TCP/IP connection to a CICS subsystem, this value must match the value specified by CICS on the APPLID= parameter of the DFHSIT macro definition in the remote CICS subsystem.

This parameter is required.

CICSNETID

For an ISC TCP/IP connection to a CICS subsystem, this NETWORK ID value is either the VTAM NETID or the UOWNETQL= parameter of the DFHSIT macro definition in the remote CICS subsystem.

The CICSNETID value must match the remote system NETWORK ID.

This parameter is optional. When not specified, the NETWORKID value is derived from the VTAM NETID of the local IMS.

CICSPOINT=

For ISC links to remote CICS subsystems, the local port that this ISC link uses. This value must match a port number defined on a CICSPOINT parameter in the TCP/IP configuration statement of this IMS Connect instance.

This parameter is required.

Multiple ISC statements can specify the same port number on the CICSPORT parameter if and only if they also specify the same local IMS system on the LCLIMS parameter. However, if the ISC statements specify the same CICSAPPL value, the CICSPORT values must be unique. Otherwise, IMS Connect issues an error message and abends on startup.

IMS Connect issues an error message and abends on startup in the following circumstances:

- The same port number is specified on the CICSPORT parameters of two or more ISC statements that do not specify the same IMS system on the LCLIMS parameter.
- The CICSPORT parameter specifies a port number that is not defined on a CICSPORT parameter of the TCPIP configuration statement.

ID=

A unique ID for this ISC statement.

The name must start with an alphabetic character and can be 1 - 8 alphanumeric characters in length.

The name must be unique within the IMS Connect configuration member. If this parameter is not unique, IMS Connect issues an error message and abends on startup.

This parameter is required.

IMSPLEX=()

Enables IMSplex communications between IMS Connect and ISC. IMSplex communications are managed by the Structured Call Interface (SCI) component of the IMS Common Service Layer (CSL).

If another IMSPLEX statement in this member of the IMS PROCLIB data set already joins IMS Connect to the IMSplex in which the ISC-enabled IMS system is a member, then this IMSPLEX substatement is optional; however, at least one IMSPLEX statement must be specified in the HWSCFGxx member of the IMS PROCLIB data set to enable IMSplex communications between this IMS Connect instance and ISC.

If an IMSPLEX substatement is not included on the ISC statement, and more than one IMSPLEX statement is specified elsewhere in this HWSCFGxx member of the IMS PROCLIB data set, IMS Connect uses the first IMSPLEX statement in the HWSCFGxx member of the IMS PROCLIB data set for communications between IMS Connect and ISC.

MEMBER=

A 1- to 8-character alphanumeric name that identifies IMS Connect in the IMSplex. The name must start with an alphabetic character. IMS Connect registers this name with SCI.

For dynamic ISC terminals that are defined to IMS by a logon descriptor, this name must match the name specified on the LCLICON parameter of the logon descriptor in either the DFSDSCMx or DFSDSCTy PROCLIB member of the local IMS system.

For ISC terminals that are statically defined to IMS by a TERMINAL system definition macro, this name must match the *iconname* value specified on the ISCTCPIP parameter of the DFSDCxxx PROCLIB member of the local IMS system.

Note: An IMS Connect instance can register only a single name in an IMSplex. If the same IMSplex name is specified on two or more TMEMBER parameters in the HWSCFGxx member of the IMS PROCLIB data set, then the same IMS Connect name must be specified on each of the corresponding MEMBER parameters. If the MEMBER parameters differ on two or more IMSplex statements that specify the same IMSplex name, IMS Connect issues an error message and abends on startup.

TMEMBER=

The name of the IMSplex that IMS Connect is joining, as specified on the IMSPLEX(NAME=) statement of the CSLSIxxx member of the IMS PROCLIB data set of the SCI instance that is managing communications between IMS Connect and the IMSplex.

Restriction: The name specified on the TMEMBER parameter cannot be the same as a name specified on the ID parameter of any DATASTORE statement.

LCLIMS=

This is the IMS ID of the local IMS system as registered with SCI in the IMSplex. It is a 1- to 8-character alphanumeric name that begins with an alphabetic character.

The values of the NODE keyword and the LCLIMS keyword must create a unique pair among all ISC statements in the IMS Connect configuration member.

You can determine the IMS IDs of the IMS systems that are registered with SCI by issuing the QUERY IMSPLEX command in the local IMSplex.

This parameter is required.

NODE=

The name of this ISC node as defined to the local IMS.

For static terminal definitions, the value specified on the NODE parameter must match both the NAME parameter on the TERMINAL system definition macro and the *nodename* value of the ISCTCPIP parameter on the DFSDCxxx PROCLIB member.

For dynamic terminal definitions, the value specified on the NODE parameter is used only in the / OPNDST command when a user initiates a new session with the CICS subsystem specified on the CICSAPPL parameter.

The values of the NODE keyword and the LCLIMS keyword must create a unique pair among all ISC statements in the IMS Connect configuration member.

This parameter is required.

RMTCICS=

For a connection to a CICS subsystem, specifies the ID of the RMTCICS statement that defines the TCP/IP connection that this ISC link uses to communicate with a remote CICS subsystem. This value must match the value of the ID= parameter of a RMTCICS statement that is defined in the IMS Connect configuration PROCLIB member.

When multiple ISC links connect to the same CICS subsystem, they can use the same TCP/IP connection definition or they can use separately defined TCP/IP connections. ISC links that use the same TCP/IP connection must specify the same ID on the RMTCICS parameter. ISC links that use separately defined TCP/IP connections to the same CICS subsystem must specify different IDs on the RMTCICS parameter; however the different RMTCICS statements that each ISC statement references must specify the same host name or IP address and port number.

This parameter is required.

Related tasks

[ISC support for TCP/IP \(Communications and Connections\)](#)

Related reference

[“DFSDCxxx member of the IMS PROCLIB data set” on page 736](#)

Use the DFSDCxxx member of the IMS PROCLIB data set to define data communication options.

[QUERY IMSCON TYPE\(ISC\) command \(Commands\)](#)

MSC statement

The MSC statement defines a one-way send path for an MSC physical link between a local IMS system to a remote IMS system.

The physical link send path uses a TCP/IP socket connection established by this IMS Connect instance with a remote IMS Connect instance. The connection used by the physical link must be defined to this IMS Connect instance by an RMTIMSCON statement.

The remote IMS Connect instance must define corresponding RMTIMSCON and MSC statements. Each MSC logical link assigned to a physical link requires two socket connections: one established by the local IMS Connect to send transaction messages and one established by the remote IMS Connect instance to return the reply messages.

MSC statement syntax

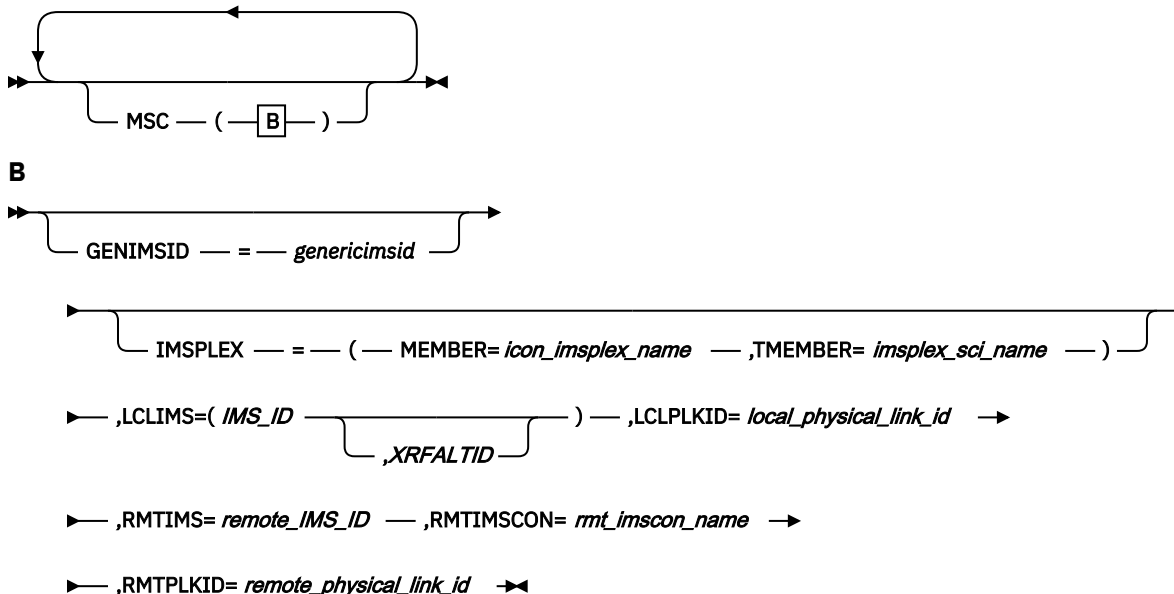

MSC statement parameters

GENIMSID=

This is an optional parameter. The MSC TCP/IP generic IMS ID that each participating IMS system in the local IMSplex also specifies on the GENIMSID parameter of the DFSDCxxx member of the IMS PROCLIB data set.

The GENIMSID parameter accepts a 1 - 8 character alphanumeric name that begins with an alphabetic character. The value of GENIMSID cannot be the same name as the values specified on either the LCLIMS or RMTIMS parameters.

IMSPLEX=()

Enables IMSplex communications between IMS Connect and MSC. IMSplex communications are managed by the Structured Call Interface (SCI) component of the IMS Common Service Layer (CSL).

If another IMSPLEX statement in this member of the IMS PROCLIB data set already joins IMS Connect to the IMSplex in which the MSC-enabled IMS system is a member, then this IMSPLEX substatement is optional; however, at least one IMSPLEX statement must be specified in the HWSCFGxx member of the IMS PROCLIB data set to enable IMSplex communications between this IMS Connect instance and MSC.

If an IMSPLEX substatement is not included on the MSC statement, and more than one IMSPLEX statement is specified elsewhere in this HWSCFGxx member of the IMS PROCLIB data set, IMS Connect uses the first IMSPLEX statement in the HWSCFGxx member of the IMS PROCLIB data set for communications between IMS Connect and MSC.

MEMBER=

A 1- to 8-character alphanumeric name that identifies IMS Connect in the IMSplex. IMS Connect registers this name with SCI. For MSC communications, this name must match the name specified on the LCLICON parameter of the MSPLINK macro definition of the local IMS system. The name must start with an alphabetic character.

Note: An IMS Connect instance can register only a single name in an IMSplex. If the same IMSplex name is specified on two or more TMEMBER parameters in the HWSCFGxx member of the IMS PROCLIB data set, then the same IMS Connect name must be specified on each of the corresponding MEMBER parameters. If the MEMBER parameters differ on two or more IMSplex statements that specify the same IMSplex name, IMS Connect issues an error message and abends on startup.

TMEMBER=

The name of the IMSplex that IMS Connect is joining, as specified on the IMSPLEX(NAME=) statement of the CSLSIxxx member of the IMS PROCLIB data set of the SCI instance that is managing communications between IMS Connect and the IMSplex.

Restriction: The name specified on the TMEMBER parameter cannot be the same as a name specified on the ID parameter of any DATASTORE statement.

LCLIMS=

For a link to a non-XRF IMS system, specifies the IMS ID of the local IMS system as registered with SCI in the IMSplex. It is a 1- to 8-character alphanumeric name that begins with an alphabetic character.

For a link to IMS systems that form an XRF pair, specifies either the IMS ID of one of the IMS systems in the pair, or, optionally, the IMS IDs of both of the IMS systems in the pair. If the IMS ID of only one of the IMS systems in the XRF pair is specified, a separate MSC statement must be coded for the other IMS system in the pair.

For example, to define a link to an XRF pair by using one MSC statement, you might code the following statement:

```
MSC=(LCLPLKID=MSC13,RMTPLKID=MSC,LCLIMS=(IMS1,IMS2),RMTIMS=IMS3,GENIMSID=IMS)
```

Alternatively, to define a link to an XRF pair by using two MSC statements, you might code the following MSC statements:

```
MSC=(LCLPLKID=MSC13,RMTPLKID=MSC,LCLIMS=IMS1,RMTIMS=IMS3,GENIMSID=IMS)
MSC=(LCLPLKID=MSC13,RMTPLKID=MSC,LCLIMS=IMS2,RMTIMS=IMS3,GENIMSID=IMS)
```

You can determine the IMS ID that is registered with SCI by issuing the QUERY IMSPLEX command in the local IMSplex.

LCLPLKID=

The local name of the MSC physical link. The name specified on the LCLPLKID parameter identifies the MSC physical link to IMS Connect. The name also associates the definitions in this MSC statement with the physical link definitions in an MSPLINK macro statement on the local IMS system.

This name must match the name specified on the LCLPLKID parameter of the MSPLINK macro.

The name must start with an alphabetic character and can be 1 - 8 alphanumeric characters in length.

RMTIMS=

This is the IMS ID of the remote (target) IMS system as registered with SCI in the remote IMSplex. It is a 1- to 8-character alphanumeric name that begins with an alphabetic character.

You can determine the IMS ID that is registered with SCI by issuing the QUERY IMSPLEX command in the remote IMSplex.

RMTIMSCON=

The remote IMS Connect connection to use for MSC messages. The value of RMTIMSCON must match the value of the ID parameter of one of the RMTIMSCON statements specified in the local IMS Connect configuration.

RMTPLKID=

The remote name of the MSC physical link as specified on the LCLPLKID parameters of both the MSC statement of the remote IMS Connect and the MSPLINK macro of the remote IMS system. The name must start with an alphabetic character and can be 1 - 8 alphanumeric characters in length.

ODACCESS statement

The ODACCESS statement defines connection attributes for IMS DB communications.

On the client side, the ODACCESS statement defines connection attributes between IMS Connect and the IMS Universal drivers and other DRDA clients. On the server side, the ODACCESS statement defines attributes for connections between IMS Connect and the CSL Open Database Manager (ODBM). IMS

Connect must register with ODBM to enable access to IMS DB for clients that use the IMS Open Database architecture.

Specify only one ODACCESS statement.

ODACCESS statement syntax



ODACCESS statement parameters

APPL=

Specifies the 1- to 8- character application name that is defined to RACF in the PTKTDATA class for IMS Connect clients that access IMS DB by using the Distributed Relational Database Architecture (DRDA) protocol. The value that is specified on this parameter is used, in addition to the user ID and the RACF PassTicket, by IMS Connect in the RACF call RACROUTE REQUEST=VERIFY to authenticate the IMS Connect client to IMS DB.

This parameter is optional and defaults to blanks. If a RACF PassTicket is passed from a DRDA client to IMS Connect but this parameter is not specified, the HWS ID from the **ID=** parameter of the HWS statement is used instead by IMS Connect on the RACF call RACROUTE REQUEST=VERIFY.

This parameter is used only if **RACF=Y** is specified in the HWS statement of the HWSCFGxx member.

DRDAPORT=

Defines the port numbers, the TCP/IP keep alive value, and the timeout values for the ports that IMS Connect uses to provide access to IMS for client applications of the Open Database APIs and user-written DRDA client applications.

The total combined number of ports that can be defined in an IMS Connect configuration member cannot exceed 200 ports. Ports defined by the DRDAPORT parameter are included in the count toward the maximum.

If you use SSL with DRDA ports, implement SSL using the z/OS Application Transparent Transport Layer Security (AT-TLS), which performs SSL processing at the z/OS TCP/IP layer.

Subparameters of DRDAPORT:

ID=

The port number of the port being defined by the DRDAPORT parameter. Port numbers are specified by a 1- to 5-character numeric value. Valid port numbers are from 1 to 65535. Port numbers must be unique among all ports used by IMS Connect within the TCP/IP domain, including the basic TCP/IP ports specified on the PORT or PORTID parameter and any Secured Socket Layer (SSL) port specified on the SSLPORT parameter.

KEEPAV=

A 1- to 8-character decimal field that sets the interval after which the keep alive mechanism of the z/OS TCP/IP layer sends a packet on idle connections on this port to maintain the connections. TCP/IP accepts a range of 1 seconds to 2,147,460 seconds. Specify 0 to use the Keepalive value defined in the z/OS TCP/IP stack. The default for KEEPAV is 0.

PORTTMOT=

Defines the amount of time that IMS Connect waits for the next input message from a client application that is connected on a DRDA port before IMS Connect disconnects the client.

The timeout interval is specified as a decimal integer in hundredths of a second. Valid values for PORTTMOT are from 0 to 2,147,483,647 (X'7FFFFFFF'). The default is 6,000 (1 minute). A 0 disables the timeout function.

Specifying a timeout value can avoid hang conditions when a client stops sending messages as expected due to, for example:

- A looping client application
- A terminated client application

For client connections, ODBMTMOT differs from PORTTMOT in that ODBMTMOT applies only to the first input message after a socket connection is established and PORTTMOT applies only to input messages that follow a previous input message.

The following code provides an example of DRDAPORT parameter specifications:

```
DRDAPORT=(ID=1111,KEEPAV=5,PORTTMOT=50),
DRDAPORT=(ID=2222,KEEPAV=10,PORTTMOT=500)
```

You can also create DRDA port definitions dynamically with the **CREATE IMSCON TYPE(PORT) PORTTYPE(DRDA)** type-2 command.

IMSPLEX= ()

Enables IMSplex communications between IMS Connect and ODBM. IMSplex communications are managed by the Structured Call Interface (SCI) component of the IMS Common Service Layer (CSL).

If the IMSPLEX statement in this member of the IMS PROCLIB data set already joins IMS Connect to the IMSplex in which ODBM is a member, then this IMSPLEX substatement is optional; however, at least one IMSPLEX statement must be specified in the HWSCFGxx member of the IMS PROCLIB data set to enable IMSplex communications between this IMS Connect instance and ODBM.

If an IMSPLEX substatement is not included on the ODACCESS statement, and more than one IMSPLEX statement is specified elsewhere in this HWSCFGxx member of the IMS PROCLIB data set, IMS Connect uses the first IMSPLEX statement in the HWSCFGxx member of the IMS PROCLIB data set for communications between IMS Connect and ODBM.

The IMSPLEX substatement keyword parameters include:

MEMBER=

A 1- to 8-character name that identifies IMS Connect within the IMSplex. SCI uses this name when managing communications between IMS Connect and ODBM. The name must start with an alphabetic character.

Note: An IMS Connect instance can register only a single name in an IMSplex. If the same IMSplex name is specified on two or more TMEMBER parameters in the HWSCFGxx member of the IMS PROCLIB data set, then the same IMS Connect name must be specified on each of the corresponding MEMBER parameters. If the MEMBER parameters differ on two or more IMSplex statements that specify the same IMSplex name, IMS Connect issues an error message and abends on startup.

TMEMBER=

The name of the IMSplex that manages communications between IMS Connect and ODBM. This name must match the IMSplex name that is defined in the NAME parameter of the IMSPLEX keyword of the SCI initialization member of the IMS PROCLIB data set (CSLSIxxx).

Restriction: A name specified on the TMEMBER parameter cannot be the same as a name specified on the ID parameter of a DATASTORE statement.

ODBMAUTOCONN=

Specifies whether IMS Connect automatically connects to new and existing instances of ODBM within an IMSplex.

When ODBMAUTOCONN=N is specified (or left blank), IMS Connect does not automatically register with instances of ODBM during IMS Connect initialization or when new instances of ODBM enter the IMSplex while IMS Connect is already running.

When ODBMAUTOCONN=Y is specified, IMS Connect automatically registers with all instances of ODBM currently in the IMSplex when IMS Connect initializes and with any instances of ODBM that join the IMSplex while IMS Connect is already running.

You can enable or disable automatic connection with ODBM by using the IMS Connect command SETOAUTO.

If ODBMAUTOCONN=N, you can start a connection with ODBM by using the IMS Connect command STARTOD.

ODBMTMOT=

Defines the amount of time that IMS Connect waits for both:

- A response message on connections with ODBM.
- An initial input message after a socket connection is established on connections with a client application

The timeout interval is specified as a decimal integer in hundredths of a second. Valid values for ODBMTMOT are from 0 to 2 147 483 647 (X'7FFFFFFF'). The default value is 18 000 (3 minutes). A value of 0 disables the timeout function.

For connections with ODBM, specifying a timeout value can avoid hang conditions when an ODBM instance stops responding.

For connections to a client application, specifying a timeout value terminates a socket connection if a client does not send data after obtaining the socket connection before the ODBMTMOT value expires.

For example, if you specify a value of 1000, if a client application establishes a socket connection with IMS Connect and then does not send an input message within 10 seconds, IMS Connect terminates the socket connection; however, if the client application establishes a socket connection and sends an input message within 10 seconds, but after IMS Connect sends the input message to ODBM, IMS Connect does not receive a response from ODBM within 10 seconds, IMS Connect returns message HWSJ2530W to the client application and retains the socket connection.

For client connections, ODBMTMOT differs from PORTTMOT in that ODBMTMOT applies only to the first input message after a socket connection is established and PORTTMOT applies only to input messages that follow a previous input message.

ODRACFST=

Specifies whether RACF statistics are recorded and updated when IMS Connect issues the **RACROUTE REQUEST=VERIFY** call to authenticate connections from an ODBM client to IMS DB.

This parameter is used only if RACF=Y is specified in the HWS statement of the HWSCFGxx configuration member.

N is the default value.

You can change the value of this parameter by using the SET(ODRACFST(ON)) or SET(ODRACFST(OFF)) option on the online IMS Connect command **UPD IMSCON TYPE(CONFIG)**.

Y

RACF statistics are recorded when IMS Connect issues the **RACROUTE REQUEST=VERIFY** call to authenticate connections from an ODBM client to IMS DB. If the logon is successful, a message is also issued. When you specify ODRACFST=Y, the STAT=ASIS parameter is used by IMS Connect on the **RACROUTE REQUEST=VERIFY** call. With STAT=ASIS, the RACF messages and statistics are controlled by the installation's current options on the RACF command **SETROPTS**.

After you enable RACF statistics, the statistics are recorded by RACF no more than once per day to a system management facility (SMF) data set or log stream. The SMF data set or log stream that is used to record the RACF statistics is specified in the RACF configuration.

N

RACF statistics are not recorded when IMS Connect issues the **RACROUTE REQUEST=VERIFY** call to authenticate connections from an ODBM client to IMS DB, and if the logon is successful, no message is issued. When you specify ODRACFST=N, the STAT=NO parameter is used by IMS Connect on the **RACROUTE REQUEST=VERIFY** call. With STAT=NO, the options specified on the RACF command **SETROPTS** are ignored.

For more information about the STAT= parameter of the **RACROUTE REQUEST=VERIFY** macro call, see "z/OS Security Server RACROUTE Macro Reference" in the IBM z/OS documentation.

Related tasks

[“Enabling open access to IMS data” on page 309](#)

To enable open access to IMS data, you need to set up IMS support for the IMS Universal drivers, configure the CSL Open Database Manager (ODBM), IMS Connect, and any required ODBM, IMS Connect, or Base Primitive Environment (BPE) user exits, and then start ODBM and IMS Connect.

[“Setting up AT-TLS SSL for IMS Connect” on page 300](#)

You can set up IBM z/OS Communications Server Application Transparent Transport Layer Security (AT-TLS) to set up Secure Socket Layer (SSL) on TCP/IP connections to IMS Connect. Setting up AT-TLS is the recommended method for enabling SSL for IMS Connect.

Related information

[IBM Documentation for z/OS](#)

RMTCICS statement

Use this statement to define a TCP/IP connection to a remote IBM CICS Transaction Server for z/OS subsystem for ISC communications.

You can define multiple connections to one or more remote CICS subsystems by specifying a separate RMTCICS statement for each connection. Specifying multiple connections to the same CICS subsystem can, depending on the resources available at your installation, improve the performance of communications from IMS to the CICS subsystem.

A connection defined by a RMTCICS statement can be used only for ISC LU 6.1 communications over TCP/IP.

RMTCICS statement syntax

```
RMTCICS( ID=rmtcicsname ,HOSTNAME=host_name ,PORT=port_id )
```

RMTCICS statement parameters

HOSTNAME=

The host name of the remote CICS subsystem that you are connecting to.

Your host name can be up to 60 characters in length.

An example of a host name is `www.example.com`.

ID=

The 1- to 8-character alphanumeric name that identifies this definition of a connection to a remote CICS subsystem.

The value specified here must also be specified on the RMTICICS parameter of a corresponding ISC configuration statement in the HWSCFGxx member of the IMS PROCLIB data set.

This parameter is required.

PORT=

The port number of the remote port that is used by the remote CICS subsystem. The port number must be specified as a 1- to 5-character decimal number.

This port number must match the port number defined in the TCPIP SERVICE resource definition for this ISC link in the remote CICS subsystem.

This parameter is required.

Related tasks

[ISC support for TCP/IP \(Communications and Connections\)](#)

Related reference

[“DFSDSCMx member of the IMS PROCLIB data set” on page 815](#)

When the Extended Terminal Option (ETO) is enabled, IMS generates ETO descriptors during stage 1 system definition and stores them in the DFSDSCMx member of the IMS.PROCLIB data set.

[“DFSDSCTy member of the IMS PROCLIB data set” on page 827](#)

Use the DFSDSCTy member of the IMS PROCLIB data set to specify override descriptors for the Extended Terminal Option (ETO), including logon descriptors, MFS device descriptors, MSC descriptors, and user descriptors.

[QUERY IMSCON TYPE\(RMTCICS\) command \(Commands\)](#)

RMTIMSCON statement

Use this statement to define a TCP/IP connection to a remote IMS Connect instance.

You can define multiple connections to one or more remote IMS Connect instances by specifying a separate RMTIMSCON statement for each connection.

A connection defined by an RMTIMSCON statement can be used for either OTMA messages or MSC messages, but not both.

For OTMA connections, an RMTIMSCON statement is required by the sending IMS Connect instance only.

For Multiple Systems Coupling (MSC) connections, a corresponding RMTIMSCON statement must also be specified in the HWSCFGxx member of the IMS PROCLIB data set of the remote IMS Connect instance.

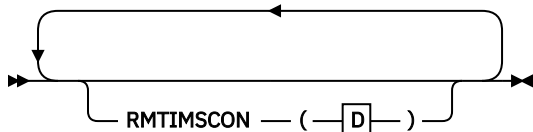
RMTIMSCON statement syntax

D

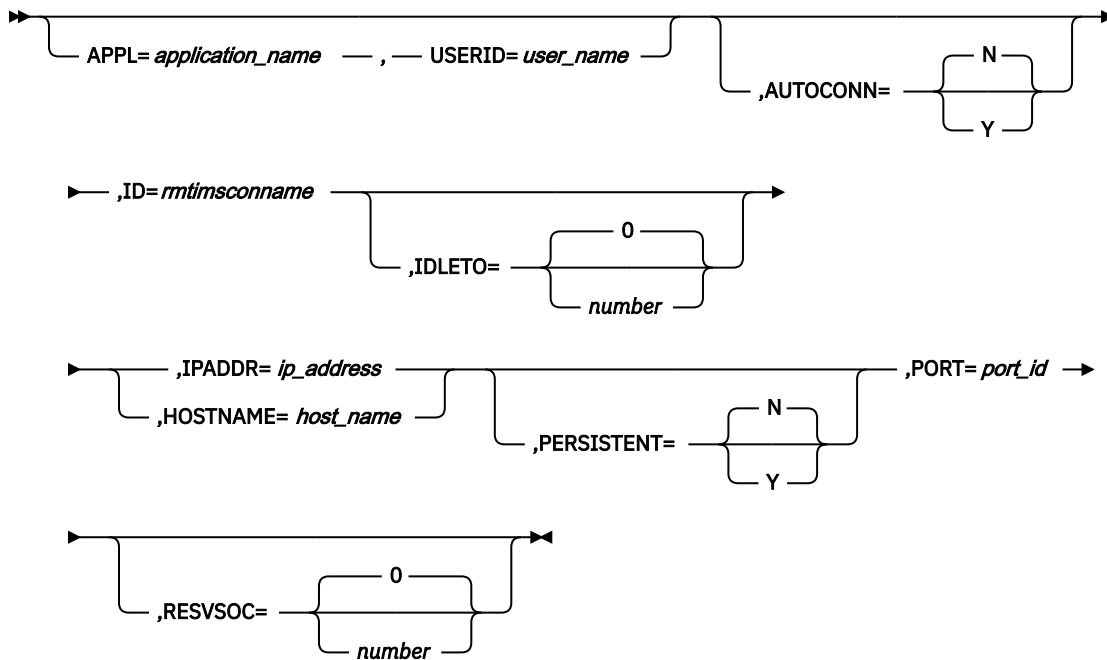

RMTIMSCON statement parameters

APPL=

Specifies the 1- to 8-character alphanumeric application name to use in a RACF PassTicket that is sent to the remote IMS Connect instance. If it is configured to use RACF, the remote IMS Connect instance passes the PassTicket to RACF to authenticate the user.

You must specify both the APPL and USERID parameters to secure a connection to a remote IMS Connect instance by using RACF. If only one of the two parameters is specified, IMS Connect abends at startup.

You can specify no more than 50 RMTIMSCON statements.

Recommendation: If RACF is not enabled in the remote IMS Connect instance, do not specify either the USERID or the APPL parameters, to avoid unnecessarily generating a PassTicket that is not used.

AUTOCONN=

For OTMA connections, determines whether this IMS Connect instance connects to the remote IMS Connect instance during startup.

To connect during startup, a persistent connection is required. You can define an OTMA connection as persistent by specifying PERSISTENT=Y in this RMTIMSCON statement. If both PERSISTENT=N and AUTOCONN=Y are specified, IMS Connect uses AUTOCONN=N and issues the message HWX0920W.

AUTOCONN is an optional parameter.

AUTOCONN= accepts the following values:

N

During startup, this IMS Connect instance does not establish socket connections to the remote IMS Connect instance. The socket connections are made only when messages are sent to the remote IMS Connect instance.

AUTOCONN=N is the default.

Y

During startup, for OTMA connections defined as persistent, this IMS Connect instance establishes one or more socket connections with the remote IMS Connect instance. You can specify the number of socket connections that IMS Connect makes at startup on the RESVSOC parameter in this RMTIMSCON statement.

Restriction: MSC links do not support AUTOCONN=Y. If AUTOCONN=Y is specified in an RMTIMSCON statement that is referenced by an MSC statement, IMS Connect uses AUTOCONN=N and issues message HWSX0920W during startup.

HOSTNAME=

The host name of the remote IMS Connect instance that you are connecting to.

Your host name can be up to 60 characters in length.

An example of a host name is www.example.com.

You must specify either the HOSTNAME or the IPADDR parameter, but not both.

ID=

The 1- to 8-character alphanumeric name that identifies this definition of a connection to a remote IMS Connect instance.

If this connection is used for MSC messages, the value specified here must also be specified on the RMTIMSCON parameter of a corresponding MSC configuration statement in the HWSCFGxx member of the IMS PROCLIB data set.

If this connection is used for OTMA messages, the value specified here must also be specified in either the RMTIMSCON parameter of a corresponding OTMA destination descriptor or in an OTMA User Data Formatting exit routine (DFSYDRU0).

This parameter is required.

IDLETO=

Specifies the amount of time open socket connections can remain idle before they are terminated due to inactivity. The timeout interval is in hundredths of seconds. Timeout values can be from 0 to 2 147 483 647 (X'7FFFFFFF'). A value of 0 prevents inactive connections from timing out.

This parameter is optional and applies only to persistent socket connections. The default value is 0.

Restriction: MSC links do not support the timeout function. If a timeout value is specified in an RMTIMSCON statement that is referenced by an MSC statement, IMS Connect resets the value 0 and issues message HWSX0920W.

IPADDR=

The IP address of the remote IMS Connect instance you are connecting to.

You can specify the IP address as either an IPv4 32-bit address or an IPv6 128-bit address.

An example of an IPv4 32-bit address is: 127 . 0 . 0 . 1

An example of an IPv6 128-bit address is: 2001 : DB8 : 0 : 0 : 0 : 0 : 0 : 0

You must specify either the IPADDR or the HOSTNAME parameter, but not both.

PERSISTENT=

Defines the sockets used for this connection as persistent. This parameter is optional.

Recommendation: For OTMA connections, to reduce storage usage at the remote IMS installation, specify PERSISTENT=Y. When persistent socket connections are used, less storage is used because the remote OTMA creates fewer tpipes.

PERSISTENT=N requires more tpipes because IMS Connect generates a unique client ID for each new socket connection, and for every unique client ID, the remote OTMA instance creates a tpipe. Moreover, until the timeout for idle tpipes cleans them up, the tpipes persist at the remote installation after the socket connection is closed by the local IMS Connect.

For MSC connections, if PERSISTENT=N is specified or accepted as the default, IMS Connect changes the value to PERSISTENT=Y and issues message HWSX0920W, because MSC links require a persistent connection. Specifying PERSISTENT=Y for MSC connections avoids the HWSX0920W message.

N

Socket connections from this instance of IMS Connect to the remote IMS Connect instance are not persistent. After a message is sent through this connection, the connection is closed.

This value is the default.

Y

Socket connections from this instance of IMS Connect to the remote IMS Connect instance are persistent.

PORT=

The 1- to 5-character decimal port number of the remote IMS Connect instance that you are connecting to. This port number must match a port number defined on either the PORT or PORTID parameter of the TCPIP configuration statement of the remote IMS Connect instance.

This parameter is required.

RESVSOC=

The number of send sockets that IMS Connect reserves for use by this connection. IMS Connect reserves this number of sockets from the maximum number of sockets allowed for this instance of IMS Connect, as specified in the MAXSOC parameter in the TCPIP statement.

RESVSOC is an optional parameter. The default value is 0.

For OTMA connections, when both the AUTOCONN=Y and PERSISTENT=Y parameters are specified, IMS Connect opens the number of sockets specified on the RESVSOC parameter during startup.

For MSC connections, use a RESVSOC value that is equal to or greater than the number of MSC logical links that are using this remote IMS Connect connection. If additional send sockets are required above the number specified on the RESVSOC parameter, IMS Connect opens them only if doing so does not increase the total number of open sockets past the number specified on the MAXSOC parameter.

Each MSC logical link requires two sockets: one send socket and one receive socket. RESVSOC reserves only the send sockets. The receive sockets required by MSC are not reserved. When calculating the total number of sockets required by IMS Connect for the MAXSOC keyword on the TCP/IP configuration statement, account for the additional receive sockets used by MSC by doubling the total number sockets specified on the RESVSOC keyword of all RMTIMSCON statements used by MSC.

Restrictions: The sockets reserved by the RESVSOC parameter are subject to the following restrictions related to the value specified on the MAXSOC parameter of the TCPIP statement:

- In the local IMS Connect configuration member, the sum of all the RESVSOC values on all RMTIMSCON statements cannot exceed the total value of the MAXSOC parameter of the TCPIP configuration statement.
- In the remote IMS Connect configuration member, the value of the MAXSOC parameter must be large enough to account for the sum of all RESVSOC parameters on all RMTIMSCON statements that connect to the remote IMS Connect instance, plus the number of connections from any other clients that the remote IMS Connect instance might support.

In the local IMS Connect configuration member, the sum of all RESVSOC parameters on RMTIMSCON statements that connect to the same remote IMS Connect instance cannot exceed the value of the MAXSOC parameter of the remote IMS Connect instance.

USERID=

Specifies the 1- to 8-character, alphanumeric user ID to use in a RACF PassTicket that is sent to the remote IMS Connect instance. RACF=Y must be specified in the configuration member of the remote IMS Connect instance to complete the security implementation. If the remote IMS Connect instance is not configured to support RACF, the remote IMS Connect instance ignores the PassTicket and the connection is not secured.

Recommendation: If RACF is not enabled in the remote IMS Connect instance, do not specify either the USERID or the APPL parameters, to avoid unnecessarily generating a PassTicket that is not used.

You must specify both the USERID and APPL parameters for RACF security support. If only one of the two parameters is specified, IMS Connect abends at startup.

TCPIP statement

The TCPIP statement defines characteristics of the communication between TCP/IP and IMS Connect. Specify only one TCPIP statement.

TCPIP statement syntax

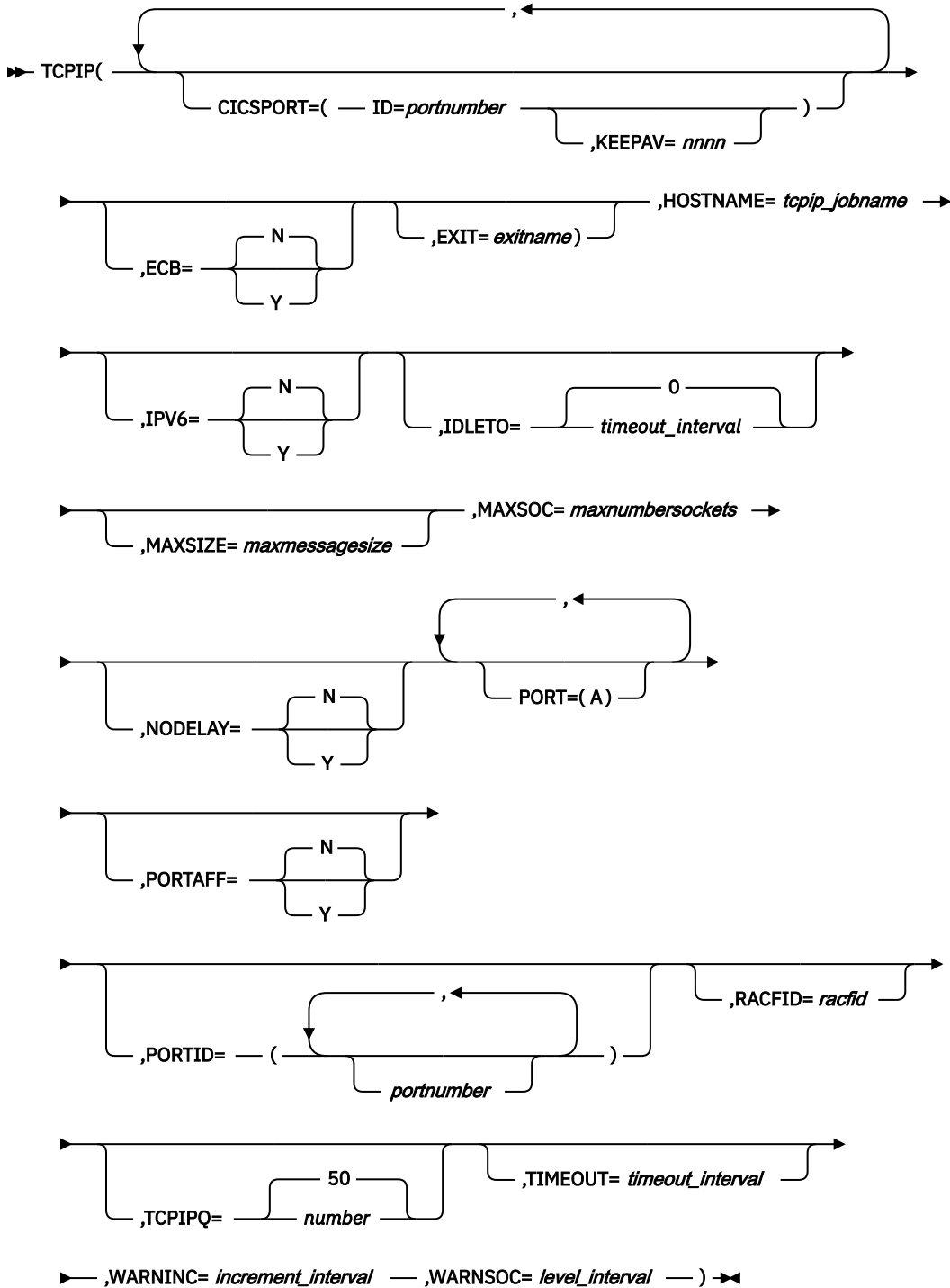

A

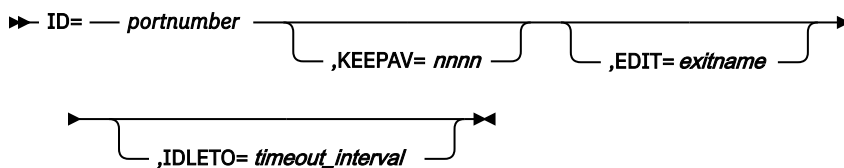

TCP/IP statement parameters

The TCP/IP statement keyword parameters are as follows:

CICSPORT

Specifies a local TCP/IP port through which IMS Connect communicates with CICS.

The total combined number of ports that can be defined in an IMS Connect configuration member cannot exceed 200 ports. Ports defined by the CICSPORT parameter are included in the count toward the maximum.

ID

Specifies a 1- to 5-character decimal field that defines a TCP/IP port. Valid values are a decimal number from 1 to 65535.

Port numbers must be unique among all ports specified on the TCP/IP statement and must not conflict with other ports selected in the TCP/IP domain.

Port numbers can be duplicated across multiple ISC statements. If multiple ISC statements specify the same CICS port, the port attributes specified in the first ISC statement remain unchanged.

KEEPAV

Specifies a 1- to 8-character decimal field of the number of seconds for the TCP/IP KeepAlive interval for sockets on this port. TCP/IP accepts a range from 1 to 2147460 seconds. If you specify zero, the KeepAlive interval value is bypassed and the setting for the TCP/IP stack is used (this is the default).

The TCP/IP KeepAlive function enables you to detect error situations on inactive sockets. KEEPAV enables you to override the default TCP/IP KeepAlive interval value. This interval can be specified for each TCP/IP port that IMS Connect uses, and it is set for all the sockets for that port.

ECB=

Specifies whether TCP/IP exit or ECB (Event Control Block) processing is to be used. ECB processing enhances IMS Connect performance by increasing throughput. Set ECB to yes (Y) or no (N).

Y

When ECB=Y is specified, IMS Connect executes with TCP/IP driving IMS Connect with the posting of an ECB.

N

When ECB= N is specified (or left blank), IMS Connect executes with TCP/IP driving an IMS Connect exit. No is the default.

EXIT=

Specifies the 1- to 8-alphanumeric character names of one or more IMS Connect user message exit routines that receive control when messages are received from and sent to TCP/IP clients. For example, EXIT=(EZAEXIT,EZBEXIT,EZCEXIT,HWSCSLO0,HWSCSLO1). You can specify a maximum of 254 user message exit routines.

The exit routines specified on the EXIT parameter support OTMA linkage through IMS Connect to IMS, as well as OM command clients for IMSplexes. To use OM command clients, such as IBM Management Console for IMS and Db2 for z/OS, with IMS Connect, you must specify HWSCSLO0 and HWSCSLO1 on the EXIT parameter.

Restrictions:

- Do not specify HWSUINIT in this parameter. Doing so will cause IMS Connect to abend. The HWSUINIT exit routine is called only during IMS Connect startup and termination and is not a user message exit routine.
- Do not specify HWSJAVA0 in this parameter. It is automatically loaded by IMS Connect after you install it in the ADFSLOAD library.

HOSTNAME=

A 1- to 8-alphanumeric character field set to the TCP/IP JOBNAME.

IDLETO=

For ports defined by either the PORT= or PORTID= parameter, specifies a default timeout interval for open socket connections that are idle and are waiting in a RECV state for the next message. This default timeout value can be overridden for individual ports that are defined by the PORT= parameter by specifying IDLETO= in the port definition.

When the timeout interval expires, IMS Connect closes the socket connection due to inactivity.

The timeout interval is in hundredths of seconds. Timeout values can be 0 - 2 147 483 647 (X'7FFFFFFF'). A value of 0 disables this timeout function, which prevents inactive connections from timing out.

This parameter is optional and applies only to persistent socket connections. The default value is 0.

IPV6=

At IMS Connect startup time, determines whether Internet Protocol Version 6 (IPv6) is enabled. Set this parameter to yes (Y) or no (N). If you leave this field blank, the default value is used.

Y

IPv6 is used.

N

IPv4 is used. This is the default.

MAXSIZE=

Specifies the maximum message size that is allowed in the 4-byte length field that precedes the IMS request message (IRM). Use the MAXSIZE= keyword to override the internal default of 10 000 000 bytes.

MAXSOC=

A decimal value between 50 and 65 535 that sets the maximum total number of sockets that this instance of IMS Connect can open. The maximum number of physical connections that can be made is the MAXSOC= value less the number of ports, because IMS Connect uses one socket on each port for listening. For example, if you specify MAXSOC=80 and have five ports, 75 physical connections can be made. The default value is 50.

When IMS Connect starts, each regular port has a socket count of 1, which reflects the port listen socket.

When the number of sockets reaches the MAXSOC limit, IMS Connect refuses any new connections and issues message HWSS0771W. After the number of connections falls below the MAXSOC value, IMS Connect resumes accepting connections.

Important: The IMS Connect **MAXSOC** parameter is related to the z/OS UNIX System Services parameter **MAXFILEPROC**, which can be overridden by the **FILEPROCMAX** field of the OMVS segment of a user's profile. The values of **MAXSOC** and **MAXFILEPROC** must be compatible. If the values of each parameter are not compatible, IMS Connect cannot open any ports. The values are compatible when the value for **MAXFILEPROC** or its override **FILEPROCMAX** value is equal to or greater than the value of **MAXSOC**.

You can ensure the compatibility between **MAXSOC** and **MAXFILEPROC** by using one of the following methods:

1. The recommended method is to use the **ALTUSER** command to assign the desired value to the **FILEPROCMAX** field of the OMVS segment of the user ID that is used to start IMS Connect.

For example, the user ID *USRID01* (not a super user) is used to start IMS Connect with **MAXSOC=20000**. **MAXFILEPROC=999** is set in the BPXPRMxx member of the z/OS SYS1.PARMLIB data set. Since **MAXSOC** is greater than **MAXFILEPROC**, IMS Connect would fail to open any of its ports. To avoid this failure, specify **FILEPROCMAX** with a value at least equal to **MAXSOC** by using the following command:

```
ALTUSER USRID01 OMVS(FILEPROCMAX(20000))
```

The new **FILEPROCMAX=20000** specification overrides the **MAXFILEPROC=999** for user ID *USRID01*.

For more information about the ALTUSER (Alter user profile) command, see [ALTUSER \(Alter user profile\)](#).

2. Before you start IMS Connect, make sure the value that is specified for **MAXSOC** is less than or equal to the value of **MAXFILEPROC**. Alternatively, your UNIX System Services administrator can directly adjust the value of **MAXFILEPROC** in the BPXPRMxx member of the z/OS SYS1.PARMLIB data set.
3. This option is no longer recommended but is retained for historical purposes. You could grant UNIX System Services superuser privileges to IMS Connect by using the RACF command **ALTERUSER** to assign an OMVS segment with a UID of 0 to the user ID of the IMS Connect started task.

IMS Connect issues message HWSP1415E TCP/IP SOCKET FUNCTION CALL FAILED; F=SETRLIMI, R=-1, E=139, M=SDOT and does not open any ports when the following conditions are met:

- IMS Connect does not have superuser privileges.
- The **MAXSOC** value is greater than the **MAXFILEPROC** value or its override **FILEPROCMAX** value.

You can check the value of MAXFILEPROC for IMS Connect by issuing the UNIX command `D OMVS, L, PID=`, where PID is the process ID for IMS Connect. You can determine the PID for IMS Connect by issuing the UNIX command: `D OMVS, V`.

Both MAXSOC and MAXFILEPROC affect the number of sockets that IMS Connect can open, but with an important difference: the MAXFILEPROC parameter limits the number of sockets for each port, whereas MAXSOC limits the total number of sockets for IMS Connect. For example, if the value of both parameters is 100, and IMS Connect has two ports, the MAXSOC limit is reached if there are 55 sockets on one port and 45 on the other. The MAXFILEPROC limit is reached only if the number of sockets on one of the ports reaches 100.

As the number of sockets on an IMS Connect port approaches the MAXFILEPROC value, UNIX System Services issues message BPXI040I. For example, "BPXI040I PROCESS LIMIT MAXFILEPROC HAS REACHED 85% OF ITS CURRENT 404". The BPXI040I message is displayed by UNIX System Services only if LIMMSG is set to SYSTEM or ALL in SYS1.PARMLIB(BPXPRMxx) or using the SETOMVS command.

When the MAXFILEPROC value is reached, IMS Connect issues the following messages:

- HWSP1415E TCP/IP SOCKET FUNCTION CALL FAILED; F=ACCEPT4, R=-1, E=124, M=SDCO
- HWSS0771W LISTENING ON PORT=*portid* FAILED; R=*rc*, S=*sc*, M=*mc*

Note that when the MAXSOC limit is reached, IMS Connect issues only the HWSS0771W message. When the MAXFILEPROC limit is reached, IMS Connect issues both the HWSP1415E and the HWSS0771W messages.

NODELAY=

Specifies whether (Y) or not (N) the TCP/IP protocol option TCP_NODELAY is to be used. The default is no.

If you specify NODELAY=Y, IMS Connect sets the TCP_NODELAY option to the IPPROTO_TCP level for all UNIX System Services API interface calls, which disables the Nagle algorithm. This parameter is valid only when sending packets.

Using the NODELAY option can enhance IMS Connect performance and increase throughput because it forces a socket to send the data in its buffer without having to wait for an ACK from the client. However, using the NODELAY option can cause network traffic to increase.

PORT=

Specifies a TCP/IP port.

The total combined number of ports that can be defined in an IMS Connect configuration member cannot exceed 200 ports. Ports defined by the PORT parameter are included in the count toward the maximum.

ID=

A 1- to 5-character field that defines a TCP/IP port. Valid values are decimal numbers from 1 to 65535.

Port numbers must be unique for a specific instance of IMS Connect unless the port numbers are specified as shared in the TCP/IP profile. For more information about TCP/IP port sharing, see [TCP/IP port sharing](#).

IDLETO=

Specifies the timeout interval for open socket connections on this port that are idle and waiting in a RECV state for the next message. When the timeout interval expires, IMS Connect closes the socket connection due to inactivity.

The timeout interval is in hundredths of seconds. Timeout values can be 0 - 2 147 483 647 (X'7FFFFFFF'). A value of 0 disables this timeout function, which prevents inactive connections from timing out.

When specified in a port definition, the value overrides the global default IDLETO value. If the IDLETO parameter is omitted from a port definition, the port uses the global IDLETO value.

This parameter is optional and applies only to persistent socket connections.

KEEPAV=

Specifies a 1- to 8-character decimal field of the number of seconds for the TCP/IP KeepAlive interval for sockets on this port. TCP/IP accepts a range from 1 to 2 147 460 seconds. If you specify zero, the KeepAlive interval value is bypassed and the setting for the TCP/IP stack is used (this is the default).

The TCP/IP KeepAlive function enables you to detect error situations on inactive sockets. KEEPAV enables you to override the default TCP/IP KeepAlive interval value. This interval can be specified for each TCP/IP port that IMS Connect uses, and it is set for all the sockets for that port.

EDIT=

A 1- to 8-character name of a Port Message Edit exit routine that can modify messages that do not conform to the standard IMS Connect message formats. The exit routine must be accessible to IMS Connect by either JOBLIB, STEPLIB, or LinkList. This field is optional. The default is no exit.

You can also create PORT definitions dynamically with the **CREATE IMSCON TYPE(PORT) PORTTYPE(REG)** type-2 command.

PORTAFF=

Specifies that commit-then-send (CM0) output messages that IMS sends to this IMS Connect have affinity to the port on which IMS Connect received the original input message. When PORTAFF=Y, IMS returns all CM0 output for this IMS Connect to the same port on which it received the original input message. IMS Connect identifies the port by using the port ID number as specified in the PORTID parameter of the TCP/IP configuration file. When PORTAFF=N, IMS Connect attempts to return the CM0 output to the first port on which it finds the client ID of this IMS Connect. PORTAFF=N is the default.

PORTID=

A 1- to 5-character field that defines the TCP/IP port. Valid values are decimal numbers from 1 to 65535. Port numbers must be unique for a specific instance of IMS Connect unless the port numbers

are specified as shared in the TCP/IP profile. For more information about TCP/IP port sharing, see [TCP/IP port sharing](#).

For TCP/IP port communications, specify the port number or numbers that bind to the socket. Port numbers that are not specified as shared must not conflict with other ports selected in the TCP/IP domain.

You can use either the PORTID keyword or the PORT keyword of the TCP/IP statement to define a TCP/IP port. Use the PORT keyword to specify a TCP/IP KeepAlive value or a Port Message Edit exit routine for a port.

The total combined number of ports that can be defined in an IMS Connect configuration member cannot exceed 200 ports. Ports defined by the PORTID parameter are included in the count toward the maximum.

The following example is a valid PORTID configuration:

```
PORTID=(9999,8888,7777)
```

RACFID=

A 1- to 8-alphanumeric character field set to the default RACF ID for exits to pass to OTMA for security checking if the RACF ID has not explicitly been set in the incoming message or by the user exit.

Note: AT-TLS is the recommended method to enable SSL for IMS Connect.

TIMEOUT=

A decimal integer field to disconnect the client. The timeout interval is in hundredths of seconds. The maximum value of timeout is 2147483647 (X'7FFFFFFF') and the default is 0 (which means no timeout). The range is from 0 to 2147483647.

IMS Connect uses the timeout value to determine the amount of time to wait for a response from IMS that is being sent to the client. This timeout value is used to prevent the client from appearing to be "hung." A hang condition occurs when the IMS host application is not responding, because either:

- The IMS program for this transaction code is stopped
- The dependent region that would run the transaction is not active
- The IMS host application is looping

The client sets a second timeout value in the IRM (IMS Request Message) header field IRM_TIMER for use with a READ to OTMA following a RESUME TPIPE call (see *IMS Version 15.4 Communications and Connections* for more information), and the ACK following the READ(s) for a RESUME TPIPE.

This timeout value is also used to disconnect a client and not send data following a client socket connection. If the timeout value is set to 10 seconds, and the client application performs a socket connection, then the client application has 10 seconds in which to send the transaction code and data. If the socket connection is made and the client application delays for more than 10 seconds, the socket connection terminates. This timeout value on an IMS Connect read of the client only applies to the wait time between the socket connection and the first input from the client application. The timeout function is not activated between reads but only between the connection and the first IMS Connect read of the client application input.

TCPIPQ=

Specifies the number of connection requests without assigned sockets that IMS Connect can maintain. The minimum value is 50, which is also the default. The maximum is 2147483647.

If this value is greater than the value of SOMAXCONN, the value of SOMAXCONN is used instead. SOMAXCONN is specified in the PROFILE.TCPIP data set. The default value for SOMAXCONN is 10.

WARNINC=

Specifies a warning level incremental percentage. After the WARNSOC value is reached, every time the number of sockets increases by the percentage value specified on WARNINC, IMS Connect reissues warning message HWSS0772W. You can specify a value between 1 and 49. The default value is 5 if not specified otherwise. If a value of less than 1 is specified, IMS Connect sets WARNINC=1. If a value greater than 49 is specified, then IMS Connect sets WARNINC=49.

WARNSOC=

Specifies a warning level when the number of sockets increases to a certain percentage of the MAXSOC limit. When the number of sockets that are currently supported reaches this warning level, IMS Connect issues a warning message, HWSS0772W. For example, if MAXSOC=2000 and you set WARNSOC to 75, message HWSS0772W is issued when the number of sockets reaches 1500.

The value of the warning level can be from 50 to 98. The default value is 80 if the **WARNSOC** parameter is not specified. If a value less than 50 is specified, IMS Connect sets WARNSOC=50.

The warning level works together with the warning increment percentage that is defined by the **WARNINC** parameter. If the sum of **WARNSOC** and **WARNINC** is greater than 99, IMS Connect uses the default values WARNSOC=80 and WARNINC=5. The maximum value of the warning level that could be set is WARNSOC=98 with WARNINC=1.

When the number of sockets decreases to the reset percentage, IMS Connect issues a HWSS0773I message to indicate that the number of sockets is no longer reaching the maximum sockets limit. The reset percentage is two times the WARNINC value, below the WARNSOC value, or 5 percent below the WARNSOC value, whichever is lowest.

Here is an example of what happens when using the default WARNSOC=80 and WARNINC=5 values:

- When the number of sockets increases to 80% of the MAXSOC value, IMS Connect issues the first HWSS0772W message.
- When the number of sockets increases to 85%, IMS Connect issues the second HWSS0772W message.
- When the number of sockets increases to 90%, IMS Connect issues the third HWSS0772W message.
- When the number of sockets decreases to 89% and increases to 90% again, IMS Connect does not issue a HWSS0772W message. This prevents IMS Connect from flooding the console with messages.
- When the number of sockets decreases to the reset percentage of 70%, IMS Connect issues a HWSS0773I message and resets the warning limits.
- When the number of sockets increases to 80%, 85%, and so on again, IMS Connect issues the HWSS0772W warning messages again.

Related concepts

[IMS Connect migration considerations \(Release Planning\)](#)

Related reference

[Format of user portion of IRM for HWSSMPL0, HWSSMPL1, and user-written message exit routines \(Communications and Connections\)](#)

IMS Connect configuration examples

The following examples of IMS Connect configuration statements show how to enable various IMS Connect functions and support during IMS Connect system definition.

You can also find a sample IMS Connect configuration member, HWSCFG00, in the ADFSSMPL data set.

Important: In all the example configurations shown, you can continue parameters beyond an 80-column line by using any combination of the following techniques:

- Inserting a comma followed by three blanks, then continuing the parameter on the next line. An example of this technique is shown in the [IMS Connect Example 1 Configuration File](#).
- Using all 80 columns of a line, then continuing in the next statement. You do not need to use a continuation indicator (such as an "x" in column 72).

Example of a simple IMS Connect configuration for IMS TM support

The following figure is an example of a simple IMS Connect system configuration for IMS TM support.

Example 1 (simple) system diagram

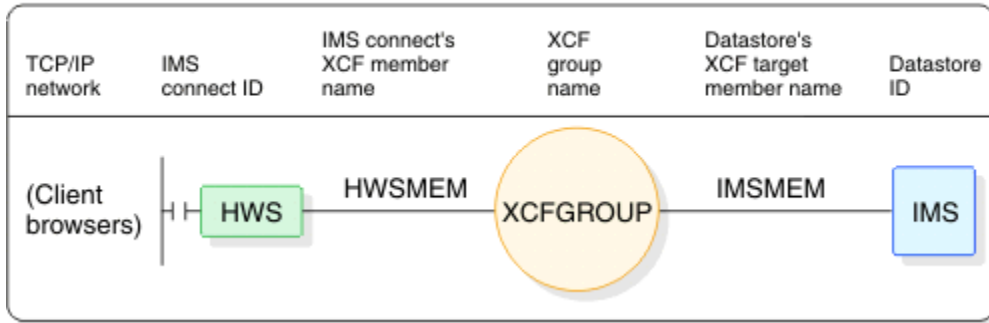

Figure 54. Simple IMS Connect system configuration for IMS TM support

In the following example of an IMS Connect configuration member:

- The IMS Connect ID is defined as HWS. This IMS Connect is configured to include the ports defined for TCP/IP communications and the IMS OTMA group and member names for communication with IMS.
- The TCP/IP configuration defines the HOSTNAME as MVSTCPIP, the RACFID as RACFID, the PORTID as 9999, and the EXIT as HWSSMPL0.
- The data store configuration defines the ID as IMS, the GROUP as XCFGROUP, the MEMBER as HWSMEM, and the TMEMBER as IMSMEM.

```
*****
* IMS Connect example configuration file
*****
HWS (ID=HWS,RACF=N,XIBAREA=20)
TCP/IP (HOSTNAME=MVSTCPIP,RACFID=RACFID,PORTID=(9999),MAXSOC=2000,TIMEOUT=8888,
EXIT=(HWSSMPL0))
DATASTORE (ID=IMS,GROUP=XCFGROUP,MEMBER=HWSMEM,TMEMBER=IMSMEM,DRU=HWSYDRU0)
```

Example of a complex IMS Connect configuration for IMS TM support

The following figure shows an example of a more complex IMS Connect system configuration for TM support.

Example 2 (complex) system diagram

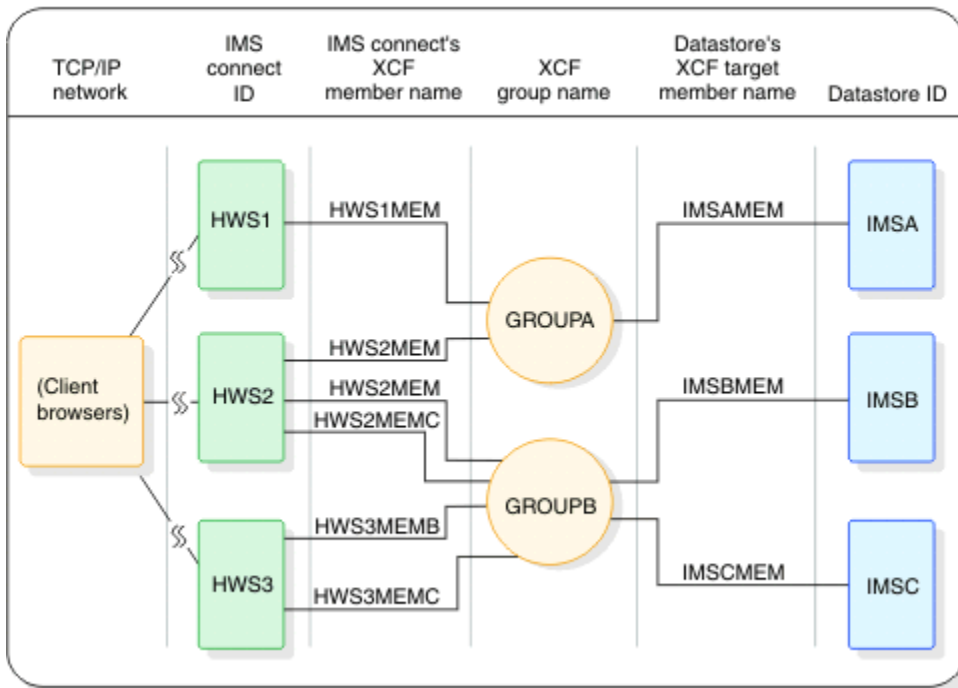

Figure 55. Complex IMS Connect system configuration for IMS TM support

In following example of an IMS Connect configuration member:

- Three IMS Connects are configured. Each IMS Connect has its own configuration member.
- Each IMS Connect uses a different port number for TCP/IP communications and can belong to multiple z/OS cross-system coupling facility (XCF) groups.
- One or more IMS systems can belong to each XCF group.
- When defining multiple data stores that belong to the same XCF group in a single IMS Connect configuration member, the XCF member name for that IMS Connect must be unique in each DATASTORE statement. However, if the data stores are members of different XCF groups, the XCF member names can be the same for different data stores within a single IMS Connect configuration member.

For example, observe that the XCF member name for IMS Connect in the IMSA and IMSB DATASTORE statements in the HWS2 configuration member in the configuration example, HWSMEM2, is the same for both DATASTORE statements. The IMSA and IMSB data stores are members of different XCF groups—GROUPA and GROUPB—so the XCF member names can be identical. These member names could have been made unique, for example, HWS2MEMA and HWS2MEMB, but it is not necessary to do so. However, the XCF member names for IMS Connect in the IMSB and IMSC DATASTORE statements in the HWS2 configuration member are different because the IMSB and IMSC data stores are members of the same XCF group, GROUPB.

```

*****
* IMS Connect example configuration member for HWS1
*****
HWS (ID=HWS1,RACF=N,XIBAREA=20)
TCP/IP (HOSTNAME=MVSTCPIP,RACFID=RACFID,PORTID=(9999),MAXSOC=2000,TIMEOUT=8888,
EXIT=(HWSSMPL0))
DATASTORE (ID=IMSA,GROUP=GROUPA,MEMBER=HWS1MEM,TMEMBER=IMSAMEM,DRU=HWSYDRU0)
*****

*****
* IMS Connect example configuration member for HWS2
*****
HWS (ID=HWS2,RACF=N,XIBAREA=20)
TCP/IP (HOSTNAME=MVSTCPIP,RACFID=RACFID,PORTID=(9998),MAXSOC=2000,TIMEOUT=8888,
EXIT=(HWSSMPL0))
DATASTORE (ID=IMSA,GROUP=GROUPA,MEMBER=HWS2MEM,TMEMBER=IMSAMEM,DRU=HWSYDRU0)
DATASTORE (ID=IMSB,GROUP=GROUPB,MEMBER=HWS2MEM,TMEMBER=IMSBMEM,DRU=HWSYDRU0)

```

```

DATASTORE (ID=IMSC, GROUP=GROUPB, MEMBER=HWS2MEMC, TMEMBER=IMSCMEM, DRU=HWSYDRU0)
*****

*****
* IMS Connect example configuration member for HWS3
*****
HWS (ID=HWS3, RACF=Y, XIBAREA=20)
TCPIP (HOSTNAME=MVSTCPIP, RACFID=RACFID, PORTID=(9997), MAXSOC=2000, TIMEOUT=8888,
EXIT=(HWSSMPL0))
DATASTORE (ID=IMSB, GROUP=GROUPB, MEMBER=HWS3MEMB, TMEMBER=IMSBMEM, DRU=HWSYDRU0)
DATASTORE (ID=IMSC, GROUP=GROUPB, MEMBER=HWS3MEMC, TMEMBER=IMSCMEM, DRU=HWSYDRU0)
*****

```

Example of IMS Connect support for ISC links between IMS and CICS.

The following example shows a simple configuration member for an IMS Connect instance that supports ISC parallel sessions on an ISC link between IMS and IBM CICS Transaction Server for z/OS.

Instead, the ISC statement defines the connection to IMS via the Structured Call Interface (SCI) of the Common Service Layer (CSL). A DATASTORE statement is not required.

The CICSPOINT keyword on the TCPIP statement defines port that IMS Connect receives transactions and reply data from CICS.

```

HWS=(ID=HWS1, XIBAREA=100, RACF=N)
TCPIP=(HOSTNAME=TCPIP, PORTID=(9998, 19998, LOCAL), RACFID=GOFISHIN,
TIMEOUT=000,
IPV6=Y,
PORT=(ID=15554),
CICSPOINT=(ID=1111, KEEPAV=1000),
CICSPOINT=(ID=3333, KEEPAV=1000),
CICSPOINT=(ID=6666, KEEPAV=1000),
CICSPOINT=(ID=7777, KEEPAV=1000),
EXIT=(HWSSMPL0, HWSSMPL1, HWSCSL00, HWSCSL01, HWSOAP1))
ISC=(ID=CICSA1, NODE=LU6NDPA,
IMSPLEX=(MEMBER=HWS1, TMEMBER=PLEX1),
LCLIMS=IMS1, RMTICIS=CICS1, CICSAPPL=CICS1, CICSPOINT=1111)
ISC=(ID=CICSA2, NODE=LU6NDPB,
IMSPLEX=(MEMBER=HWS1, TMEMBER=PLEX1),
LCLIMS=IMS1, RMTICIS=CICS1, CICSAPPL=CICS1, CICSPOINT=3333)
ISC=(ID=CICSA5, NODE=ISCTCP1,
IMSPLEX=(MEMBER=HWS1, TMEMBER=PLEX1),
LCLIMS=IMS1, RMTICIS=CICS1, CICSAPPL=CICS1, CICSPOINT=6666)
ISC=(ID=CICSA6, NODE=ISCTCP2,
IMSPLEX=(MEMBER=HWS1, TMEMBER=PLEX1),
LCLIMS=IMS1, RMTICIS=CICS1, CICSAPPL=CICS1, CICSPOINT=7777)
RMTICIS=(ID=CICS1, HOSTNAME=ABC.EXAMPLE.COM, PORT=23456)

```

Example of IMS Connect configuration for IMS-to-IMS connections

The following sets of configuration statements provide examples of how to configure both IMS Connect instances that support an IMS-to-IMS TCP/IP connection.

The examples are shown in two sets two.

The following set of configuration statements show an example of the IMS Connect configuration statements required to support MSC.

The following two sets of example configuration statements define a connection for an MSC link between two instances of IMS Connect. One set of configuration statements is for a local IMS Connect instance, HWS1, and one set is for a remote IMS Connect instance, HWS2. Both IMS Connect instances require both a RMTIMSCON statement and an MSC statement because MSC links support message traffic in both directions.

```

*****
* IMS Connect configuration statements for an MSC IMS-to-IMS connection
*****

```



```

*****
* Local HWS1 configuration statements
*****
HWS=(ID=HWS1,XIBAREA=20,RACF=Y)
TCP/IP=(HOSTNAME=TCPIP,PORTID=(9999),
        MAXSOC=50,RACFID=RACFID,TIMEOUT=5000)
RMTIMSCON=(ID=ICON2,HOSTNAME=ICON2.IBM.COM,PORT=5555,
           IDLETO=0,AUTOCONN=N,PERSISTENT=Y,
           RESVSOC=10,USERID=USER01,APPL=APPL01)
MSC=(LCLPLKID=MSC12,RMTPLKID=MSC21,
     IMSPLEX=(MEMBER=HWS1,TMEMBER=PLEX1),
     LCLIMS=(IMS1),RMTIMS=IMS2,RMTIMSCON=ICON2)
*****

*****
* Remote HWS2 configuration statements
*****
HWS=(ID=HWS2,XIBAREA=20,RACF=Y)
TCP/IP=(HOSTNAME=TCPIP,PORTID=(5555),
        MAXSOC=50,RACFID=RACFID,TIMEOUT=5000)
RMTIMSCON=(ID=ICON1,HOSTNAME=ICON1.IBM.COM,PORT=9999,
           IDLETO=0,AUTOCONN=N,PERSISTENT=Y,
           RESVSOC=10,USERID=USER02,APPL=APPL02)
MSC=(LCLPLKID=MSC21,RMTPLKID=MSC12,
     IMSPLEX=(MEMBER=HWS2,TMEMBER=PLEX2),
     LCLIMS=(IMS2),RMTIMS=IMS1,RMTIMSCON=ICON1)
*****

```

The following two sets of example configuration statements define a one-way OTMA connection between two instance of IMS Connect. One set of configuration statements is for a local IMS Connect instance, HWS1, that sends OTMA messages, and one set is for a remote IMS Connect instance, HWS2, that receives the OTMA messages.

```

*****
* IMS Connect configuration statements for an OTMA IMS-to-IMS connection
*****

*****
* Local HWS1 configuration statements
*****
HWS=(ID=HWS1,XIBAREA=20,RACF=N)
TCP/IP=(HOSTNAME=TCPIP,PORTID=(9999),
        MAXSOC=50,RACFID=RACFID,TIMEOUT=5000)
DATASTORE=(ID=IMS1,GROUP=XCFGRP1,MEMBER=HWS1,TMEMBER=IMS1,DRU=HWSYDRU0,
           APPL=APPLID1)
RMTIMSCON=(ID=ICON2,HOSTNAME=ICON2.IBM.COM,PORT=5555,
           IDLETO=3000,AUTOCONN=N,PERSISTENT=Y,
           RESVSOC=10,USERID=USER01,APPL=APPL01)
*****

*****
* Remote HWS2 configuration statements
*****
HWS=(ID=HWS2,XIBAREA=20,RACF=Y)
TCP/IP=(HOSTNAME=TCPIP,PORTID=(9999,5555),
        MAXSOC=50,RACFID=RACFID,TIMEOUT=6000)
DATASTORE=(ID=IMS2,GROUP=XCFGRP2,MEMBER=HWS2,TMEMBER=IMS2,DRU=HWSYDRU0,
           APPL=APPLID1)
*****

```

IMS Connect configuration statement for IMS DB support

The following example shows a simple configuration member for an IMS Connect instance that supports clients that connect to IMS DB in a DBCTL system.

When configuring IMS Connect to support only a DBCTL system, a DATASTORE statement is not required. Instead, the ODACCESS statement defines the connection to IMS via the Open Database Manager (ODBM) of the Common Service Layer (CSL). For IMS Connect to communicate with ODBM, you must code an IMSPLEX substatement in the IMS Connect configuration member. You do not identify ODBM or IMS in the configuration member. The communication and connection between IMS Connect and ODBM is managed automatically by IMS Connect and ODBM through the Structured Call Interface (SCI) component of CSL.

When ODBMAUTOCONN=Y is specified, as shown in the example, IMS Connect automatically connects to all active ODBM instances in the IMSplex that is specified on the TMEMBER parameter of the IMSPLEX substatement. Communications with the IMS systems that are defined to the ODBM instances is also automatically enabled.

If ODBMAUTOCONN=N, IMS Connect does not connect to ODBM during startup. Communication can then be enabled for ODBM instances and IMS systems individually by issuing the STARTIA command.

Although the values of ID on the HWS statement and MEMBER on the IMSPLEX substatement are the same in the example, the values do not need to match.

```
*****
* IMS Connect example for IMS Universal drivers and DRDA client support
*****
HWS (ID=HWS1,RACF=N,XIBAREA=20)
TCP/IP (HOSTNAME=MVSTCPIP,RACFID=RACFID,MAXSOC=2000)
ODACCESS (DRDAPORT=(ID=1111,KEEPAV=5,PORTTMOT=50),
IMSPLEX=(MEMBER=HWS1,TMEMBER=PLEX1),
ODBMAUTOCONN=Y)
*****
```

The following figure illustrates the configuration defined in the preceding example.

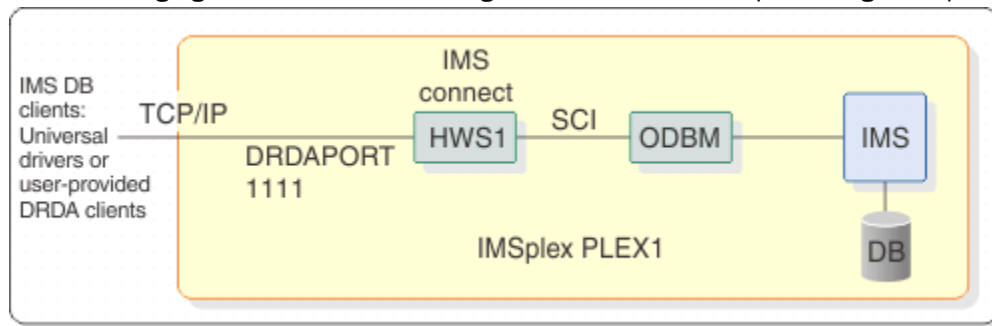

Figure 56. Simple IMS Connect system configuration for IMS DB support

Additional IMS Connect configuration statement examples

The following series of IMS Connect configuration statements are examples of how to configure IMS Connect to support various functions, including:

- OM command clients, such as IBM Management Console for IMS and Db2 for z/OS
- Internet Protocol version 6 (IPV6)
- RACF PassTicket
- Secure Sockets Layer (SSL)
- XML conversion with the XML adapter
- IMS Universal drivers and DRDA client

Note: AT-TLS is the recommended method to enable SSL for IMS Connect.

```
*****
* IMS Connect example of including the support for OM command clients
*****
HWS (ID=HWS4,RACF=Y,XIBAREA=20)
TCP/IP (HOSTNAME=MVSTCPIP,RACFID=RACFID,PORTID=(9999,LOCAL),MAXSOC=2000,
TIMEOUT=8800,
EXIT=(HWSCSL00,HWSCSL01,HWSMPL1))
IMSPLEX (MEMBER=HWS4,TMEMBER=PLEX1)
*****

*****
* IMS Connect example of including the support for OM command clients and IPV6
*****
HWS (ID=HWS4,RACF=Y,XIBAREA=20)
TCP/IP (HOSTNAME=MVSTCPIP,RACFID=RACFID,PORTID=(9999),MAXSOC=2000,TIMEOUT=8800,
EXIT=(HWSCSL00,HWSCSL01,HWSMPL1),IPV6=Y)
IMSPLEX (MEMBER=HWS4,TMEMBER=PLEX1)
```

```

*****
*****
* IMS Connect example of including the APPL name for passticket support
*****
HWS (ID=HWS5,RACF=Y,XIBAREA=20)
TCP/IP (HOSTNAME=MVSTCPIP,RACFID=RACFID,PORTID=(9999),MAXSOC=2000,TIMEOUT=8800,
EXIT=(HWSSMPL0)
DATASTORE (ID=IMS,GROUP=XCFGROUP,MEMBER=HWSMEM,TMEMBER=IMSMEM,DRU=HWSYDRU0,
APPL=APPLID1)
*****

*****
* IMS Connect example of including the support for SSL
*****
HWS (ID=HWSG7,RACF=N,XIBAREA=20)
TCP/IP (HOSTNAME=TCIPI,PORTID=(9998),
EXIT=(HWSSMPL0)
DATASTORE (ID=SOCKEYE,MEMBER=COHO,TMEMBER=CHINOOK,GROUP=SALMON)
*****

*****
* IMS Connect example of including XML adapter support
*****
HWS (ID=HWS8,RACF=Y,XIBAREA=20)
TCP/IP (HOSTNAME=MVSTCPIP,RACFID=RACFID,
PORTID=(9999,LOCAL,MAXSOC=2000,TIMEOUT=8800,
EXIT=(HWSSMPL1,HWSSOAP1)
ADAPTER (XML=Y,MAXCVRT=200)
*****

```

Related tasks

[“Configuring XML conversion support for IMS Connect clients” on page 303](#)

You must configure IMS Connect to convert the input and output messages between an IMS Connect client and an IMS application from XML to a language-specific structure, when the IMS Connect client is IMS Enterprise Suite SOAP Gateway.

[“Configuring IMS Connect” on page 298](#)

IMS Connect supports communication between one or more TCP/IP clients and IMS systems. You can configure multiple IMS systems on multiple z/OS images within a single sysplex and distribute the client request to the IMS systems (data stores).

Related reference

[Format of user portion of IRM for HWSSMPL0, HWSSMPL1, and user-written message exit routines \(Communications and Connections\)](#)

Chapter 21. Other control statements used in IMS environments

These topics include control statements that can be used in an IMS environment.

Sequential buffering control statements

Use sequential buffering control statements to specify I/O operations that require sequential buffering (SB), capture internal calls to the SB buffer handler, take a snapshot of SB control blocks, and perform an SB buffer handler self-check.

This section describes the control statements you can use to modify sequential buffering definitions.

Syntax of SB control statements

SB control statements are contained in 80-character records. Positions 72-80 are ignored.

Each SB control statement must begin on a new record. The first record must contain at least the statement name. IMS considers the first non-blank character the start of the statement. The first word on the statement must be the statement name, such as SBPARM and SBIC, followed by one or more blanks.

Depending upon the type of SB control statement, one or more keyword parameters follow the statement name. Keywords must be followed immediately by an equal (=) sign and a value. If you specify multiple keywords, separate them with commas. If you specify multiple values, enclose them in parentheses. Individual keyword parameters must be contained on a single record.

A blank or a /* signals the end of a statement. You can continue SB control statements on multiple records. Use a comma at the end of a line to indicate continuation.

An asterisk (*) in the first position on a record indicates a comment. Elsewhere on a record, comments begin with /*.

Two examples of proper syntax follow:

```
SBPARM ACTIV=COND,DB=SKILLDB,BUFSETS=6 /*Comment

SBPARM ACTIV=COND, /*This is a comment
        DB=SKILLDB, /*This is a comment
        BUFSETS=6 /*This is a comment
```

SB parameters (SBPARM) control statement

The SBPARM control statement is used to:

- Specify which I/O operations require sequential buffering (I/O operations can be specified by database, PCB, ddname, and PSB)
- Override SB default parameters

All SBPARM parameters are optional.

The format of the SBPARM control statement is:

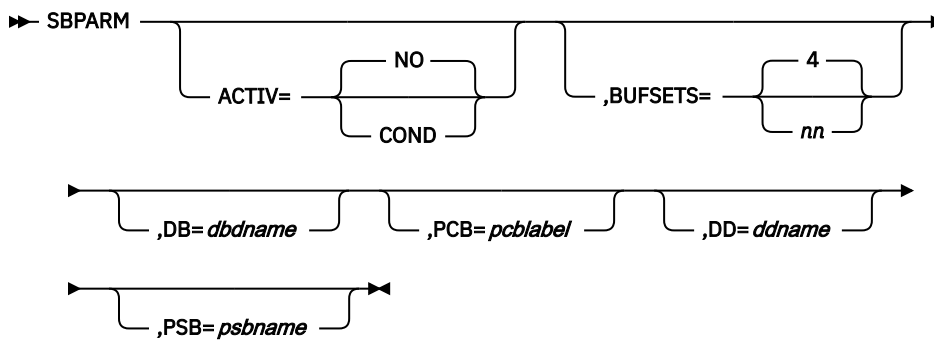

Default values are underlined. The default value, however, might have been overridden by other specifications. If you provide the same SB option or parameter in more than one place, the following priority list applies (item 1 has the highest priority):

1. SB control statement specifications (the n th control statement overrides the m th control statement, where $n > m$)
2. PSB specifications
3. Defaults changed by the SB Initialization exit routine

If you specify multiple SBPARM control statements applying to the same I/O operation, the n th control statement overrides the m th one (where $n > m$). This lets you specify defaults on the first statement which can be overridden by subsequent statements.

The SBPARM control statement has two types of keyword parameters:

1. Option parameters, such as ACTIV= and BUFSETS=, which set and override an SB option or parameter, respectively
2. Qualification parameters, such as DB, PCB, DD, and PSB, which specify the I/O operations to which the SBPARM statement applies

Option parameters

Option parameters set or override an SB option or parameter. If an option parameter is not specified, the previously established value of the parameter is in effect. The previously established value might have been set by an IMS default, the SB Initialization exit routine, PSBGEN, or preceding SBPARM statements.

ACTIV=

Specifies if and when SB should be activated.

NO

Specifies that SB is not activated. NO is the default; however, the default might have been changed by what is specified in the SB Initialization exit routine, PSBGEN, or a preceding SBPARM control statement.

COND

Specifies that IMS monitors the I/O reference patterns of PCBs and eventually activates SB if analysis shows the I/O reference pattern is sequential, and the rate of I/O activity is high enough.

Recommendation: Specify COND for batch and BMP programs that sometimes or always process a database sequentially. Do not use SB for short-running MPP, Fast Path, or IBM CICS Transaction Server for z/OS programs because of the overhead associated with initializing SB for each program execution.

If ACTIV= is not specified on an SBPARM control statement, IMS uses the previously established value of the ACTIV parameter. Therefore, omitting ACTIV lets you override the BUFSETS parameter without inadvertently changing SB PSBGEN specifications.

BUFSETS=

Specifies how many buffer sets are to be allocated for a given SB buffer pool. You can specify a value from 1 through 25. The default is 4. (The default can be changed by the SB Initialization exit routine.)

Each SB buffer pool consists of n buffer sets. Each buffer set has 10 buffers. Each buffer is large enough to hold one OSAM data set block.

You must specify a value greater than 1 if SB is to use overlapped I/O.

A well-organized database might only require a BUFSETS value of 2 for efficient sequential buffering. Less well-organized databases might require a BUFSETS value of 6 or more. One indicator of database organization can be found in the optional //DFSSTAT reports. If, for a sequential program, these reports show a low percentage of random I/O operations, this can indicate a well-organized database. Conversely, a high percentage of random I/O can indicate a poorly organized database. In either case, the //DFSSTAT reports can help you adjust the BUFSETS value to improve buffering performance.

Qualification parameters

Qualification parameters specify the I/O operations to which the SBPARM statement applies. You can associate SBPARM statements with a database, PCB, ddname, or PSB.

You can specify any combination of qualification parameters. If you specify more than one qualification parameter, the SBPARM statement applies only to I/O operations that satisfy all qualification parameters. If you do not specify any qualification parameters, the SBPARM statement applies to all I/O operations.

DB=

Specifies the DBD name (as specified in the PCB macro of PSBGEN) of those PCBs to which the SBPARM statement applies.

If multiple PCBs have the same DBD name, and you want different specifications for different PCBs, use the PCB= keyword. If the PCB refers to multiple database data sets and you want different specifications for these data sets, use the DD= keyword.

If no DB= keyword is provided, the SBPARM statement applies to all I/O operations that satisfy the other qualification keywords.

PCB=

Specifies the label coded on the database PCB during PSBGEN. Use this keyword to distinguish between multiple PCBs with the same DBD name.

If no PCB= keyword is provided, the SBPARM statement applies to all I/O operations that satisfy the other qualification keywords.

DD=

Specifies the ddname of the database data set to which the SBPARM statement applies. Use this keyword to distinguish between multiple data sets to which the PCB refers.

If no DD= keyword is provided, the SBPARM statement applies to all I/O operations that satisfy the other qualification keywords.

PSB=

Specifies the name of the PSB to which the SBPARM statement applies.

If no PSB=keyword is provided, the SBPARM statement applies to all I/O operations that satisfy the other qualification keywords.

Use of the PSB= keyword is recommended for message regions. Normally, SB should not be activated for all programs running in the message region; rather, SB should be restricted to a small number (if any) of these programs. If SB is to be used for more than one program, you need to provide one SBPARM statement for each program and code the PSBname of the program on the PSB= keyword.

PSB= is also useful if you decide to centralize all SB control statements in one common SB control statement file. In this case, PSB= identifies for each SBPARM statement, the PSB or program to which it applies.

SBPARM examples	Comments
SBPARM ACTIV=COND	SBPARM requests conditional activation of SB for all I/O operations. No default values for SB parameters are overridden.

SBPARM examples	Comments
SBPARM ACTIV=COND, DB=SKILLDB	SBPARM requests conditional activation of SB for I/O operations associated with all PCBs coded with DBDNAME=SKILLDB during PSBGEN. No default values for SB parameters are overridden.
SBPARM ACTIV=COND, DB=SKILLDB, PCB=LABEL1	SBPARM requests conditional activation of SB for all PCBs that satisfy both of the following conditions: <ul style="list-style-type: none"> • DBDNAME=SKILLDB coded during PSBGEN • The PCB label coded as LABEL1 during PSBGEN
SBPARM ACTIV=COND, DB=SKILLDB, BUFSETS=6	SBPARM requests conditional activation of SB for all PCBs coded with DBDNAME=SKILLDB during PSBGEN. The BUFSETS parameter is set to 6 (instead of 4, which is the default). This increase in BUFSETS value can improve buffering efficiency if the database is poorly organized.
SBPARM BUFSETS=6	SBPARM requests that the default values of BUFSETS be overridden. Increasing the value of BUFSETS to 6 (rather than using the default, which is 4) can improve buffering efficiency if the database is poorly organized. In this example, ACTIV has not been coded. As a result, the SBPARM statement does not change the previously established set of I/O operations being buffered by SB.
SBPARM ACTIV=NO	SBPARM requests that SB not be used. The request applies to all I/O operations.

SB Image Capture (SBIC) control statement

The SBIC control statement captures all internal calls to the SB buffer handler. The captured information is put in the X'5E' log record.

The X'5E' log records can be used as input to the SB test program (DFSSBHD0).

Related reading: For detailed information about the SB test program (DFSSBHD0), see *IMS Version 15.4 Database Utilities*.

The format of the SBIC control statement is as follows:

➤ SBIC ➤

SB Compare Option (SBCO) control statement

The SBCO control statement asks the SB buffer handler to perform a self check to determine if SB is putting incorrect block images in the OSAM buffers, and if so, to provide problem determination information.

Problem determination information is provided in the form of a snap. In the IMS online environment, this snap is written to the IMS log. In the IMS batch environment, you can request that the snap is written to any of the following:

- The data set specified in the DFSDDLTO //PRINTDD DD statement
- A user-specified data set
- The IMS log

See “Snap Destination (SNAPDEST) control statement” on page 963 for a description of how to request these snap destinations. In the batch environment, the default snap destination is the data set specified in the //DFSSNAP DD statement.

Related reading: For detailed information about the SBCO control statement, see *IMS Version 15.4 Diagnosis*.

The format of the SBCO control statement is as follows:

➤ SBCO ➤

SB Snap (SBSNAP) control statement

The SBSNAP control statement snaps SB control blocks after each internal call of the OSAM buffer handler to the SB buffer handler. As an option, you can request that, for each internal SB call, the following additional information be snapped:

- The OSAM database block returned by the SB buffer handler to the OSAM buffer handler
- The SB buffers for the current data set group

In IMS online environment, this snap is written to the IMS log. In the IMS batch environment, you can request that the snap is written to any of the following:

- The data set specified in the DFSDDLTO //PRINTDD DD statement
- A user-specified data set
- The IMS log

See “Snap Destination (SNAPDEST) control statement” on page 963 for a description of how to request these snap destinations. In the batch environment, the default snap destination is the data set specified in the //DFSSNAP DD statement.

All SBSNAP parameters are optional.

The format of the SBSNAP control statement is as follows:

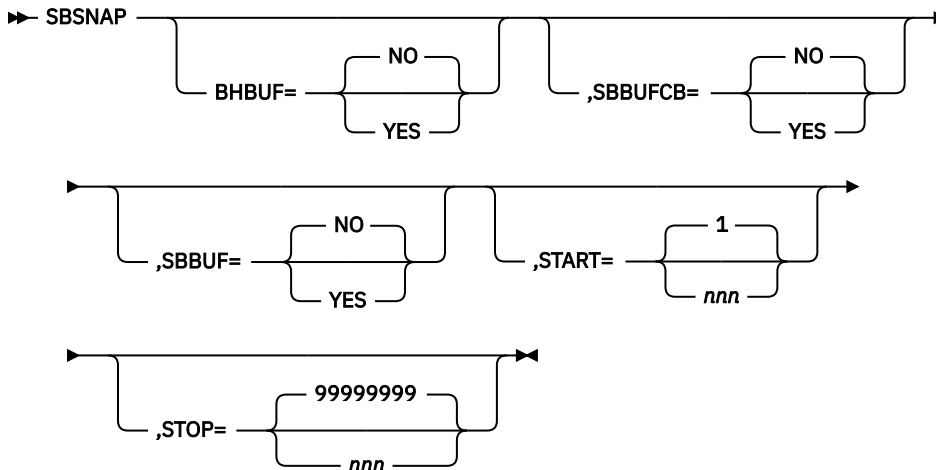

If you specify multiple SBSNAP control statements, the n -th control statement overrides the m th control statement (where $n > m$).

Related reading: For additional information about the SBSNAP control statement, see *IMS Version 15.4 Diagnosis*.

BHFBUF=

Specifies whether (YES) or not (NO) the OSAM buffer handler buffer is to be included in the snap produced at the end of each internal call to the SB buffer handler. The default is NO.

SBBUFCB=

Specifies whether (YES) or not (NO) the buffer control blocks of the SB buffer handler are to be included in the snap produced at the end of each internal call to the SB buffer handler. The default is NO.

SBBUF=

Specifies whether (YES) or not (NO) the buffers of the SB buffer handler are to be included in the snap produced at the end of each internal call to the SB buffer handler. The default is NO.

START=

Specifies that the snap is to start on the *n*th call to the SB buffer handler (instead of the first call). The default is 1.

The START= and the STOP= parameters are useful if you want to limit snapping to a specific period during which an application is running. The SBSNAP option often creates a large amount of output.

STOP=

Specifies that the snap is to be stopped on the *m*th call to the SB buffer handler (instead of the last call).

The default is that the snap is stopped after the last call.

SB Evaluation Snap (SBESNAP) control statement

The SBESNAP control statement snaps SB control blocks at the end of each periodic evaluation of the buffering process. The information in this snap can help you understand why IMS did or did not use SB.

In the IMS online environment, the snap is written to the IMS log. In the IMS batch environment, you can request that the snap is written to any of the following:

- The data set specified in the DFSDDLTO //PRINTDD DD statement
- A user-specified data set
- The IMS log

See “[Snap Destination \(SNAPDEST\) control statement](#)” on page 963 for a description of how to request these snap destinations. In the batch environment, the default snap destination is the data set specified in the //DFSSNAP DD statement.

All SBESNAP parameters are optional.

The format of the SBESNAP control statement is:

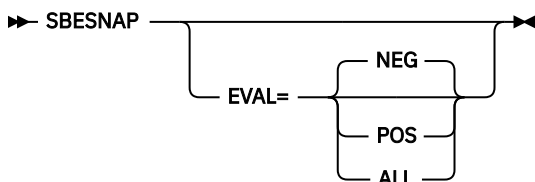

If you specify multiple SBESNAP control statements, the *n*th control statement overrides the *m*th control statement (where $n > m$).

Related reading: For additional information about the SBESNAP control statement, see *IMS Version 15.4 Diagnosis*.

EVAL=

NEG requests a snap only when a periodical evaluation results in a decision not to use SB.

POS requests a snap only when a periodical evaluation results in a decision to use SB.

ALL requests a snap whenever a periodical evaluation of a data set group is made.

The default is NEG.

Snap Destination (SNAPDEST) control statement

The SNAPDEST control statement is applicable in batch environments only. SNAPDEST specifies the destination of the snap created by the SBSNAP, SBESNAP, or SBCO options. In the IMS online environment, SNAPDEST is ignored, and snap information is written to the IMS log.

The default destination for snap information in the batch environment is the data set specified in the //DFSSNAP DD statement.

If you specify an invalid destination in the SNAPDEST control statement, IMS tries to write the snap to the IMS log.

The format of the SNAPDEST control statement is as follows:

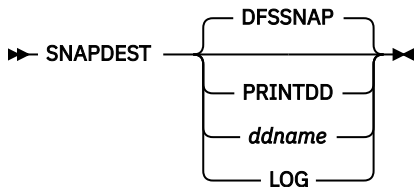

The destination specified in the SNAPDEST control statement can be any one of the following:

DFSSNAP

Specifies that snap information is to be put in the data set associated with the //DFSSNAP DD statement.

PRINTDD

Specifies that snap information is to be put in the data set associated with the //PRINTDD DD statement of the DL/I test program DFSDDLTO. This data set also contains information created by DFSDDLTO.

ddname

Specifies that snap information is to be put in the data set with the specified ddname. The DD statement for this data set must conform to z/OS requirements for snap.

When the snap destination is ddname, DCB attributes are provided by IMS. You should not code them on the DD statement.

For this type of destination, each snap opens and closes the data set. If there are many snaps, this can result in significant overhead.

LOG

Specifies that snap information is to be put in the IMS log.

When snaps are written to the log, the log record codes are as follows:

X'67ED'- snap created by the SBESNAP option

X'67EE'- snap created by the SBSNAP option

X'67EF'- snap created by the SBCO option

You can select and print these log records using the File Select and Formatting Print utility (DFSERA10) and the Log Type X'67' Record Format and Print Module (DFSERA30).

Related reading: Both of these programs are described in *IMS Version 15.4 System Utilities*.

High-speed sequential processing control statements

Use HSSP control statements to set up the environment in which you process a selected PCB with HSSP, create an image copy of a designated DEDB area, restrict access of a specific HSSP or non-HSSP application program to only designated DEDB areas, and specify where to allocate the private buffers for HSSP processing.

This section describes the syntax, keywords, and values of the three high-speed sequential processing (HSSP) control statements: SETO, SETR, and SETU.

HSSO, HSSR, and HSSD control blocks are built from SETO and SETR statements. These control blocks—specifically those that represent image copy data sets and those that are used for UOW locking—are formatted for offline dumps. These control statements are in the DFSCCTL data set.

Syntax of HSSP control statements

Each HSSP control statement must begin on a new line. IMS considers the first nonblank character the start of the statement. You must leave one or more blanks following the statement name. Keywords follow the statement name. Keywords must be followed immediately by an equal sign (=) and a value. If you specify multiple keywords, separate them with commas. If you specify multiple values, enclose them in parentheses.

A blank or a closing parenthesis signals the end of a statement. You can continue HSSP control statements on multiple records. Use a comma at the end of a line to indicate continuation.

An asterisk (*) in the first position on a record indicates a comment. Elsewhere on a record, comments begin with a slash and asterisk (/ *). You can include comments on each line with at least one blank between the keyword, value, or comma and the comment.

Set Options (SETO) control statement

The SETO control statement allows you to specify the options in processing a PCB with HSSP. With SETO, you can:

- Deactivate the HSSP option for a particular PCB
- Make an image copy of an updated area
- Specify the processing options in case of image copy failure

IMS interprets SETO when a region is started. After the region is active, you cannot alter the options.

Syntax

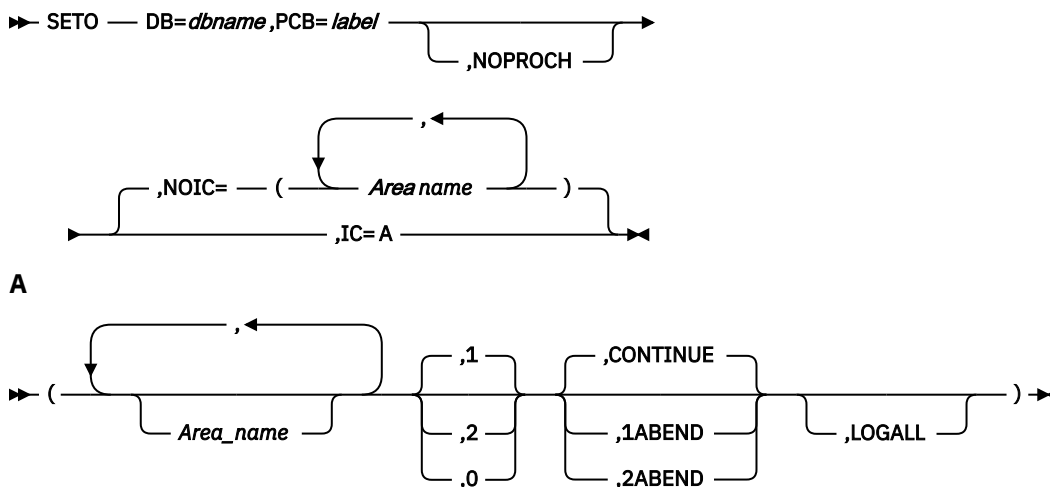

Keyword parameters

DB=

Specifies the name of the database to which SETO applies. Because HSSP is only applicable to DEDBs, only the names of these DEDBs are valid.

PCB=

Specifies a one- to eight- character label that identifies the PCB to which SETO applies. It must be identical to the label on the associated DEDB PCB. If you use the same PCB label more than once for the same database name, only the first SETO statement with that label is used.

NOPROCH

Specify NOPROCH if you want to deactivate the HSSP option that was initialized in PSBGEN (PROCOPT=H). If you specify this keyword, PROCOPT=P is set, and the IC option is ignored. You can only specify one HSSP PCB per database per PSB. If more than one HSSP PCB points to the same database, you should use the NOPROCH keyword to deactivate additional PCBs before the SETO statements are processed. If more than one HSSP PCB exists after the SETO statements have been processed, the region is not scheduled.

NOIC=

Specifies that no image copy should be made for all or some of the areas listed in DBDGEN. If you specify NOIC= without any area names, no image copy is made for any area in the database. You can use the option NOIC= with area names several times per SETO statement; however, you can specify a particular area only once. NOIC is the default if you do not specify IC=.

IC=

Specifies that an image copy should be made of all or some of the areas listed in DBDGEN. Allocation information about the image copy data sets is obtained from DBRC.

Values: The following values control the use of HSSP:

Area name

Lists the names of the areas to be image copied. If you need the areas to be processed in a specific order (other than the order in the DBDGEN), you must list them in the desired order and separate them with a comma. If the sequence of areas required is the same sequence as that in the DBDGEN, you only need to list the first and the last area names of the series and separate them with a hyphen. You can specify an area name only once. For example, A4,A1-A3,A5-A8 is valid, but A4,A1-A8 is invalid, because A4 is repeated.

If you specify IC= without any area names, an image copy of all areas in the database occurs. You can specify IC= without area names only once per SETO statement. You can use the option IC= with area names several times per SETO statement; however, you can specify an area only once.

Commas and parentheses are optional if you specify only one parameter on the IC= parameter. You must register the area in DBRC in order for image copying to take place.

1

Specifies that one image copy data set should be made. The default is one.

2

Specifies that two image copy data sets should be made. If you specify IC=2, two image copy data sets must be registered with DBRC for an area; otherwise, no image copy is done for that area.

0

Specifies that no image copy data sets should be made. IC=0 is the same as specifying NOIC.

CONTINUE | 1ABEND | 2ABEND

These keywords describe the action a program should take in the event of an image copy failure.

CONTINUE specifies that the program continues processing if the image copy option cannot be performed. Under this circumstance, messages are sent to the MTO console and the job log (WTP). CONTINUE can be abbreviated as C.

1ABEND specifies that if image copying cannot be completed for one data set, the program must abend. 1ABEND can be abbreviated as 1A.

2ABEND specifies that if image copying cannot be completed for two data sets, the program must abend. If you request IC=2 and one of the data sets is still usable, HSSP continues to write to it. 2ABEND can be abbreviated as 2A.

LOGALL

Specifies that X'5950' log records are to be logged for DEDB updates in an HSSP environment. If LOGALL is not specified, only the X'5947' log record is logged.

If you specify only one parameter on the IC= keyword, you do not need to include the parentheses or the commas. Trailing commas for those parameters you do not include are also not required. For example, IC=1 is equivalent to IC=(, 1 , ,), and IC=1, LOGALL is equivalent to IC=(, 1 , , LOGALL).

Set Range (SETR) control statement

The SETR control statement specifies the processing range of PCBs to a database during scheduling of an application program. If a PSB has several PCBs pointing to the same database, you can restrict the access of each PCB to that database. Each program can only access data in the DEDB within the range defined.

Syntax

➤ SETR — DB=*dbname*,PCB=*label* — ,SE — ,AL=(— *Area name* —) — ➤

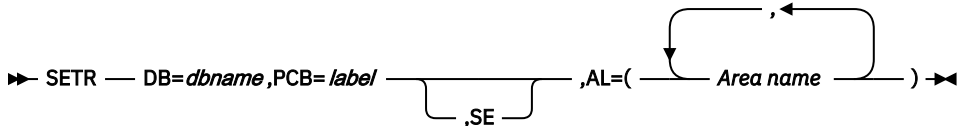

Keyword parameters

DB=

Specifies the name of the database to which the SETR statement applies.

PCB=

Specifies a one- to eight-character label that identifies the PCB to which the SETR statement applies. This label must be identical to the label on the associated DEDB PCB. If you use the same PCB label more than once for the same database name, only the first SETR statement with that label is used.

SE

An optional keyword that instructs IMS to skip processing empty areas when SETR is in effect and the area is within the specified range.

AL=

Specifies the areas to which the PCB has access. The SETR area list does not have to match the SETO area list. (The SETR area list determines which areas can be processed. The SETO area list indicates which of the processed areas must have an image copy.) If you specify the SETR statement without a matching SETO statement (that is, the same DB= and PCB= values), the SETR statement processes the specified area list (AL=) values according to the PROCOPT option in PSBGEN.

Set Buffer Storage Area (SETU) control statement

The SETU control statement specifies whether the utility private buffers for HSSP processing are to be allocated in 31-bit extended common storage (ECSA) or 64-bit common storage. If the SETU control statement is not specified, the buffers are allocated in ECSA by default.

Syntax

➤ SETU — FPBP64U= — Y — N — ➤

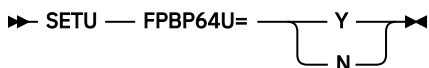

Keyword parameters

FPBP64U=

Specifies where to allocate the utility private buffers in storage.

Y

Specifies that the buffers are allocated in 64-bit common storage. FPBP64U=Y cannot be specified if IC= is specified on the SETO control statement.

N

Specifies that the buffers are allocated in 31-bit extended common storage (ECSA).

HSSP control statement examples

The following are examples of SETO, SETR, and SETU statements in the DFSCCTL data set with their associated PCBs.

Sample PSBGEN:

```
L1 PCB TYPE=DB, DBDNAME=DEDB1, PROCOPT=A
L2 PCB TYPE=DB, DBDNAME=DEDB2, PROCOPT=HI
L3 PCB TYPE=DB, DBDNAME=DEDB3, PROCOPT=HRD
L4 PCB TYPE=DB, DBDNAME=DEDB4, PROCOPT=HA
L5 PCB TYPE=DB, DBDNAME=DEDB5, PROCOPT=HG
```

First sample of DFSCCTL set option statements:

```
SETO DB=DEDB1, PCB=L1, IC=1 /* Example 1
SETO DB=DEDB2, PCB=L2, IC=(1, CONTINUE) /* Example 2
SETO DB=DEDB3, PCB=L3, IC=(A1, A3-A6, 2, 1A) /* Example 3
SETR DB=DEDB3, PCB=L3, AL=(A1-A5)
SETO DB=DEDB4, PCB=L4, IC=(2, 2ABEND) /* Example 4
SETO DB=DEDB5, PCB=L5, NOIC=(A4-A5) /* Example 5
SETO DB=DEDB5, PCB=L5, IC=1, LOGALL
```

Second sample of DFSCCTL set option statements:

```
SETU FPBP64U=Y /* Example 6
SETO DB=DEDB5, PCB=L5
```

Example 1

This SETO statement matches the PCB with label L1. However, the PROCOPT=A defines it as a non-HSSP PCB. The SETO statement is ignored.

Example 2

This SETO statement matches the PCB with label L2. The PROCOPT=HI defines it as an HSSP PCB.

IC=

Indicates a list of values for the image copy option.

1

Requests one image copy of all referenced areas. A referenced area is an area for which a DL/I call has been issued.

CONTINUE

Indicates that processing should continue if image copying cannot be performed.

Example 3

This SETO statement matches the PCB with label L3.

A1,A3-A6

Requests an image copy of each indicated area when referenced by the application.

2

Requests two image copies of all referenced areas.

1ABEND

Requests that the program must abend if one image copy fails.

This SETR statement matches the PCB with label L3. The AL=(A1=A5) sets the range of areas to which PCB L3 has access.

Example 4

This SETO statement matches the PCB with label L4.

2

Requests two image copies of all referenced areas

2ABEND

Requests that the program must abend if both image copies fail. If one image copy data set is usable, the program continues to write on it.

Example 5

This SETO statement matches the PCB with label L5.

NOIC=

Excludes the areas for which HSSP image copying is to be done.

A4–A5

Indicates the areas for which no image copies are requested.

IC=

Indicates a list of values for the image copy option.

1

Requests one image copy of all referenced areas. A referenced area is an area for which a DL/I call has been issued.

LOGALL

Indicates that updates are logged in X'5950' log records.

Example 6

The SETU statement does not require any associated PCB definitions. Because the utility private buffers are going to be allocated in 64-bit common storage, image copies cannot be made of any of the areas. If IC= were specified on the SETO statement, an error message would be issued.

Set Index Maintenance Off (SETI) control statement

The Set Index Maintenance Off (SETI) control statement enables you to suppress index maintenance for any DEDB database where the secondary index is defined for the BMP application and where the PSB is set to *psbname*.

When a DEDB database has secondary index defined, IMS automatically performs index maintenance when the source statement is inserted, updated, or deleted. The index suppression option provides the capability for updating a DEDB database with one or more secondary index defined without index maintenance. If an application has many updates to the primary DEDB database that would result in significant index maintenance to its associated secondary index database, you can suppress the index maintenance for the application. Then synchronize your primary DEDB database and its secondary index databases at a later time using an in-house application or vendor tool product.

To suppress index maintenance, specify the //DFSCTL DD statement in the JCL of the IMS BMP region.

```
//DFSCTL DD *  
SETI PSB=psbname
```

The SETI PSB=*psbname* parameter suppresses index maintenance for any DEDB database with secondary index defined for the BMP application for PSB of *psbname*.

If *psbname* in the PSB=*psbname* parameter in the SETI statement does not match the PSB name for the BMP application, or the PSB= parameter is not specified in the SETI statement, message DFS0510E is issued and the application is terminated with an ABENDU1060. You will need to correct the SETI statement and rerun the BMP application.

Specify **FPSISETI=N** to prevent the SETI statement from taking effect. The **FPSISETI** parameter is in the Fast Path section of the DFSDFxxx member. **FPSISETI=Y** is the default.

Database resource adapter startup table for CCTL regions

Use the database resource adapter (DRA) startup table to provide definitional parameters for the coordinator control (CCTL) region. The DRA startup table establishes the subsystem name of the IMS that is being connected to, and defines the characteristics of the DRA, such as the number of threads.

This topic presents sample source code for DFSPZP00 and describes the parameters that are specified through the DFSPRP macro in DFSPZP00.

Sample DFSPZP00 source code

The DRA startup table, DFSPZPxx, is created by assembling the DFSPZPxx module. This code sample is the actual source code for DFSPZP00. To define other variations of DFSPZPxx, modify this code through the DFSPRP macro. Specify the DRA parameters as keywords on the DFSPRP macro. The keywords and their descriptions are described in “DFSPRP macro keywords in DFSPZP00” on page 970.

```
*****
*
*      MODULE NAME: DFSPZP00
*
*      DESCRIPTIVE NAME: DATABASE RESOURCE ADAPTER (DRA)
*      STARTUP PARAMETER TABLE.
*
*****@SCPVRT*
* Licensed Materials - Property of IBM
*
* 5635-A01
*
* (C) Copyright IBM Corp. 1989,2011 All Rights Reserved.
*
* US Government Users Restricted Rights - Use, duplication or
* disclosure restricted by GSA ADP Schedule Contract with
* IBM Corp.
*****@ECPYRT*
*
*      FUNCTION: TO PROVIDE THE VARIOUS DEFINITIONAL PARAMETERS
*      FOR THE COORDINATOR CONTROL REGION. THIS
*      MODULE MAY BE ASSEMBLE BY A USER SPECIFYING
*      THEIR PARTICULAR NAMES, ETC. AND LINKEDITED
*      INTO THE USER RESLIB AS DFSPZPXX . WHERE XX
*      IS EITHER 00 FOR THE DEFAULT, OR ANY OTHER ALPHA-
*      NUMERIC CHARACTERS.
*
*      KEYWORDS FOR THE DFSPRP MACRO:
*      DSECT=NO-A DSECT STATEMENT FOR PRP WILL NOT BE
*      GENERATED (LABEL DFSPRP WILL BE ON DS 00).
*
*      FUNCLV=  DEFAULT (3). ADAPTER FUNCTIONAL LEVEL.
*
*      DDNAME=  1 TO 8 CHARACTER DD NAME TO BE USED WITH
*      DYNAMIC ALLOCATION OF THE DBCTL RESLIB.
*      DEFAULT (CCTLDD).
*
*      DSNAME=  1 TO 44 CHARACTER DATASET NAME OF THE
*      DBCTL RESLIB.
*      DEFAULT (IMS.SDFSRESL)
*
*      DBCTLID=XXXX-NAME OF THE DBCTL REGION
*      DEFAULT = SYS1
*
*      USERID=XXXXXXXX-NAME OF THE USER REGION
*
*      MINTHRD=XXXX-MINIMUM NUMBER OF THREADS TO BE
*      AVAILABLE (MAXIMUM NUMBER IS 4095)
*      DEFAULT = 1
*
*      MAXTHRD=XXXX-MAXIMUM NUMBER OF THREADS TO BE
*      AVAILABLE (MAXIMUM NUMBER IS 4095)
*      DEFAULT = 1
*
*      TIMER=XX-IDENTIFY TIMER VALUE IN SECONDS (DEFAULT 60)
*
*      IDRETRY=XXX-Retry IDENTIFY attempt count
*      before DFS690A message will be
*      reissued.
*      (Default = 0, Min = 0, Max =255)
*
*      FPBUF=XXXX-NUMBER OF FAST PATH BUFFERS TO BE ALLOCATED*
*      AND FIXED PER THREAD (DEFAULT 00)
*
*      FPBOF=XXXX-NUMBER OF FAST PATH OVERFLOW BUFFERS TO BE
*      ALLOCATED PER THREAD (DEFAULT 00)
*
*      SOD=X-OUTPUT CLASS TO BE USED FOR SNAP DUMP OF
*      ABNORMAL THREAD TERMINATIONS (DEFAULT A)
*
*      GENSNAP= SPECIFIES WHETHER OR NOT DFSPAT20, THE DRA
*
```

```

*          THREAD TERMINATION ROUTINE, SHOULD GENERATE *
*          SNAP OUTPUT. IF GENSNAP=YES IS SPECIFIED, *
*          SNAP OUTPUT IS GENERATED. IF GENSNAP=NO IS *
*          SPECIFIED, NO SNAP OUTPUT IS GENERATED BY *
*          DFSPAT20. (DEFAULT YES) *
*
*          TIMEOUT=XXX-DRATERM TIMEOUT VALUE IN SECONDS(DEFLT 60)*
*
*          CNBA=XXXX TOTAL FP NBA BUFFERS FOR CCTL *
*          0 - 9999 or 1K - 32K *
*          0 = *
*          If FPBUF and/or FPBOF *
*          are 0, or not specified, *
*          0 indicates no CNBA buffer *
*          If FPBUF or FPBOF are *
*          specified >0, CNBA=0 *
*          indicates IMS *
*          will determine the CNBA *
*          size based on: *
*          (MAXTHRD*FPBUF)+FPBOF *
*          1K - 32K = *
*          nnK =(nn * 1024)-1 *
*
*          AGN=XXXXXXXX-1 to 8 CHARS (THIS PARM IS NO *
*          LONGER SUPPORTED, BUT IS ALLOWED *
*          FOR COMPATIBILITY REASONS.) *
*
*          PCBLOC=24|31 Specifies the storage location *
*          of the application PCB list. *
*          24 - DIRCA allocated in 24 bit private *
*          31 - DIRCA allocated in 31 bit private *
*
*          OPENTHRD= CCTL | DISABLE *
*
*          LOCATION: PRIVATE STORAGE, USER KEY *
*
*          THIS MODULE CONTAINS NO EXECUTABLE CODE. *
*
*****

```

DFSPRP macro keywords in DFSPZP00

The following information describes DRA table parameters specified through the DFSPRP macro in DFSPZP00.

CNBA=

Is the total number of Fast Path NBA buffers for CCTL's use. Valid values for CNBA are from 0 to 9999 and 1K to 32K. The default value for CNBA is 0.

You can determine a starting value for CNBA by using the following formula: $FPBUF \times MAXTHRDS + FPBOF = CNBA$. The minimum value of CNBA must be equal to or greater than the total of the FPBUF and FPBOF values. If necessary, adjust the value of CNBA to meet the performance and storage requirements of your installation.

If the $FPBUF > 0$ or $FPBOF > 0$, and $CNBA = 0$, the IMS system calculates the CNBA size during connection request processing based on the formula.

DBCTLID=

Is the four-character name of the DBCTL region. This is the same as the IMSID parameter in the DBC procedure. The default name is SYS1. For more information about the DBC procedure, see [“DBC procedure”](#) on page 604.

DSECT=

Specifies whether a DSECT statement for PRP is generated.

YES

A DSECT statement is generated. The existing CSECT will be reestablished. The default is YES.

NO

A DSECT statement is not generated. Label DFSPRP will be on DS 0D.

DDNAME=

Is a one- to eight-character ddname to be used with the dynamic allocation of the DBCTL execution library. The default ddname is CCTLDD. This library must contain the DRA modules.

DSNAME=

Is a one- to forty-four-character data set name of the DBCTL execution library. This library must contain the DRA modules and must be z/OS authorized. The default dsname is IMS.SDFSRESL.

FPBOF=

Specifies the number of Fast Path DEDB overflow buffers to be allocated per thread. Valid values for FPBOF are from 0 to 9999. The default value for FPBOF is 0.

FPBUF=

Specifies the number of Fast Path DEDB buffers that are allocated per thread. Valid values for FPBUF are from 0 to 9999. The default value for FPBUF is 0.

FUNCLV=

Specifies the level of the DRA that the CCTL supports:

1

Base CCTL function support.

2

ODBM Callable Interface support.

3

DRA Options.

The default is 3. You should accept the default value since no other value is valid. The higher FUNCLV value includes lower values, and is required to support certain new functions.

GENSNAP=

Specifies whether DFSPAT20, the DRA thread termination routine, generates SNAP output.

YES

SNAP output is generated during thread termination. The default is YES.

NO

SNAP output is not generated during thread termination.

When ODBM connects to ODBA as a DRA client, it specifies GENSNAP=NO is to suppress the SNAP output.

MAXTHRD=

The maximum number of DRA thread TCBs available at one time. The maximum number is 4095. The default is number 1.

MINTHRD=

The minimum number of DRA thread TCBs available at one time. The maximum number is 4095. The default is number 1.

When the DRA Open Thread TCB option is active, this value refers to the number of DRA threads that are signed on to IMS.

When the DRA Open Thread TCB option is inactive, this value refers to the number of DRA thread TCBs that remain attached and signed on to IMS.

OPENTHRD=

Identifies whether DRA Open Thread support processing is enabled. When DRA Open Thread support processing is enabled and uses CICS 4.2 or higher, the OPENTHRD option directs the DRA not to attach dedicated IMS DRA thread task control blocks (TCBs). Instead, the DRA uses CICS TCBs intended for increased parallelism within the CICS/DRA environment.

CCTL

DRA Open Thread support processing is enabled.

DISABLE

DRA Open Thread support processing is disabled. This is the default.

PCBLOC=

Identifies where the application PCB list is built. It can be built either below the 16M line (PCBLOC=24), which is the default, or in extended private storage (PCBLOC=31), above the 16M line.

SOD=

Is the output class to be used for a SNAP DUMP of abnormal thread terminations. The default is A.

TIMEOUT=

Is the amount of time (in seconds) a CCTL should wait for the successful completion of a DRA TERM request. Specify this value only if the CCTL is coded to use it. This value is returned to the CCTL upon completion of an INIT request. The default is 60 seconds.

TIMER=

Is the amount of time (in seconds) between attempts of the DRA to identify itself to DBCTL during an INIT request. The default is 60 seconds.

TIMETHREADCPU=

Specifies whether the DRA monitors and reports the CPU usage statistics that are related to DRA threads, to IMS when DRA Open Thread support is enabled.

YES

The DRA monitors and reports the CPU usage statistics. A value of YES overrides any value that is specified by the CCTL. YES is the default.

NO

The DRA does not monitor and report the CPU usage statistics. A value of NO overrides any value that is specified by the CCTL.

CLIENT

The DRA uses the setting that is specified by the DRA client through the INIT call (YES or NO) . If the client does not specify a setting, YES is the default.

USERID=

Is an eight-character name of the CCTL region.

DFSDFSRT

DFSDFSRT is a REXX program that starts the z/OS Interactive Problem Control System (IPCS) with the IMS Dump Formatter.

Prerequisite: To provide access to the z/OS Interactive Problem Control System (IPCS) with the IMS Dump Formatter, include the IMS.SDFSEXEC data set in the SYSPROC DD concatenation.

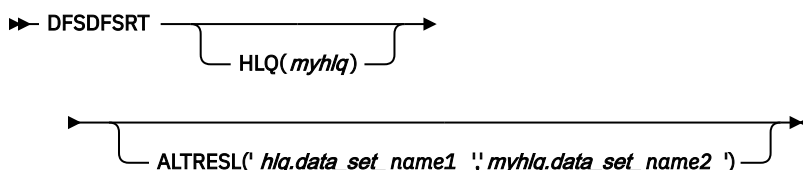

Attention: Ensure that the IPCS is started before the IMS Application Menu is started. Otherwise, message DFSIX103 is displayed. See *IMS Version 15.4 Installation* for more information about the IMS Application Menu.

DFSDFSRT syntax**DFSDFSRT keyword parameters****DFSDFSRT**

Command to start the IPCS with the IMS Dump Formatter.

HLQ

Keyword that enables you to specify the high-level qualifier of the IMS distribution data sets.

The **HLQ** parameter is required the first time you use the DFSDFSRT statement. If you do not specify a high-level qualifier, DFSDFSRT uses the most recently specified high-level qualifier. After the first required use, this parameter is optional.

myhlq

High-level qualifier of the IMS distribution data sets.

ALTRESL

Keyword that enables you to specify a list of data set names that contain load modules.

If you specify the **ALTRESL** parameter, you should include SDFSRESL in the list of data set names. If you do not specify the **ALTRESL** parameter, *myhlq.SDFSRESL* is used as the IPCS TASKLIB data set.

myhlq.data_set_name1

Fully-qualified name of a data set that contains load modules.

Starting the z/OS IPCS with the IMS Dump Formatter

To start IPCS with the IMS Dump Formatter, use either of the following commands:

- TSO %DFSDFSRT HLQ(myhlq)
- EXEC 'IMS.SDFSEXEC(DFSDFSRT)' 'HLQ(myhlq)'

IRLM use of SDUMP

The IRLM uses the z/OS SDUMP program for dumping whenever its ESTAE or FRR routines are entered. SDUMP dumps are directed to the SYS1.DUMPxx data sets and printed using the IPCS service aid. SDUMP has the same advantages over the SYSABEND dump program as the spinoff dump program. The operator is told which data set contains the SDUMP by message IEA911E COMPLETE DUMP ON SYS1.DUMPxx.

Here are sample control statements for executing the IPCS program.

```
//SYSIN DD *
NEW DUMP DD=INPUT
FORMAT
LOGDATA
VTAMMAP
IRLM irlm.subsystem.name
PRINT JOBNAME=(irlm.job.name)
END
```

Related reading: For a description of the IPCS utility, see *MVS/ESA Interactive Problem Control System (IPCS) Users Guide*.

IMS Installation Defaults module (DFSIDEF0)

You can use the DFSIDEF0 module to define options for database recovery control (DBRC). You can also use the module to define supervisor call instruction (SVC) numbers that are reserved for use by the generated IMS system.

The DFSIDEF0 module is provided in the IMS.ADFSSMPL data set.

You are not required to use the DFSIDEF0 module. If you do not use the module, or if the module cannot be loaded at initialization time, and the keywords are not specified as IMS execution parameters, IMS default values are used instead.

If you use the DFSIDEF0 module, ensure that the DFSIDEF0 module resides in an APF-authorized library that is included in the IMS Control Region JOBLIB or STEPLIB concatenation, or in the z/OS LINKLIST concatenation.

If you use the DFSIDEF0 module, ensure that you assemble and link the DFSIDEF0 module into the IMS.SDFSRESL data set. The following sample JCL assembles and binds the DFSIDEF0 module into the IMS.SDFSRESL data set:

```
//ASSEMBLE EXEC PGM=ASMA90,PARM='NOOBJ,DECK'
//SYSLIB DD DSN=IMS.SDFSMAc,DISP=SHR
//SYSPUNCH DD DISP=OLD,DSN=IMS.OBJDSET(DFSIDEF0)
//SYSPRINT DD SYSOUT=*
//SYSUT1 DD UNIT=SYSDA,DISP=(,DELETE),SPACE=(CYL,(15,15))
//SYSIN DD *
IDEF0 TITLE 'DFSIDEF0 - IMS INSTALLATION DEFAULTS BLOCK'
DFSIDEF0 CSECT
        SPACE 1
        DFSIDEF TYPE=BEGIN
        DFSIDEF TYPE=PARAM,DBRC=YES
***** DFSIDEF TYPE=PARAM,DBRC=NO
***** DFSIDEF TYPE=PARAM,DBRC=FORCE
*
***** DFSIDEF TYPE=PARAM,SVC2=254
***** DFSIDEF TYPE=PARAM,SVC4=255
        DFSIDEF TYPE=END
        END DFSIDEF0
//STEP1 EXEC PGM=IEWL,
//          PARM='SIZE=(880K,64K),NCAL,LET,REUS,XREF,LIST'
//SYSPRINT DD SYSOUT=*
//SYSPUNCH DD DSN=IMS.OBJDSET,DISP=SHR
//SYSLMOD DD DSN=IMS.SDFSRESL,DISP=SHR
//SYSUT1 DD UNIT=(SYSDA,SEP=(SYSLMOD,SYSPUNCH)),SPACE=(CYL,(10,1))
//SYSLIN DD *
INCLUDE SYSPUNCH(DFSIDEF0)
NAME DFSIDEF0(R)
```

If you specify RMODE, you must specify RMODE=24 and AMODE=24.

DFSIDEF macro keywords in DFSIDEF0

You can specify the following parameters on the DFSIDEF macro in the DFSIDEF0 module:

DBRC=

Specifies whether DBRC is to be used during this execution of IMS for batch and utility environments. The default value is YES. The **DBRC=** parameter that is specified in the DFSIDEF0 module is valid only for batch and utility environments and is ignored for all other system environments.

If **DBRC=Y** or **DBRC=N** is specified on the DFSIDEF macro, the **DBRC=** value that is specified on the DFSIDEF macro is overridden by the **DBRC=** value that is specified in the DFSPBxxx member of the IMS PROCLIB data set. To do this, you must define the RGSUF= parameter in your DLIBATCH or DBBBATCH procedure. In the DFSPBxxx member, you can specify only DBRC=N or DBRC=Y.

YES

DBRC is used during this execution of IMS.

NO

DBRC is not used during this execution of IMS.

FORCE

DBRC is always used during this execution of IMS, unless this is a batch backout execution of IMS.

If this is a batch backout execution of IMS, the **DBRC=FORCE** specification defined in DFSIDEF0 can be overridden by specifying **DBRC=NO** on the EXEC procedure. Thus, if the previous execution of IMS used DBRC but not IRLM, batch backout executes without DBRC.

SVC2=

The type 2 SVC number that IMS uses. You can specify a value in the range 200 - 255 for this parameter. The **SVC2=** parameter that is specified on the DFSIDEF macro is valid for all IMS environments.

The **SVC2=** value that is specified on the DFSIDEF macro is overridden by the value that is specified in the DFSPBxxx member or in JCL.

If the **SVC2=** parameter is not defined on the DFSIDEF macro or as an IMS execution parameter, IMS uses a default value of 254.

To generate sample JCL for relinking the type 2 SVC routine, DFSVC200, as IGCxxx, where xxx is the type 2 SVC number, specify TYPE=GEN, SVC2=xxx on the DFSIDEF macro.

SVC4=

The type 4 SVC number that IMS uses for DBRC environments. You can specify a value in the range 200 - 255 for this parameter.

If the **SVC4=** parameter is not defined in the DFSIDEF0 module, IMS uses a default value of 255.

To generate sample JCL for relinking the type 4 SVC routine, DSP00MVS, as IGC00yyy, where yyy is the EBCDIC representation of the zoned-decimal type 4 value, specify TYPE=GEN, SVC4=zzz on the DFSIDEF macro.

Notices

This information was developed for products and services offered in the US. This material might be available from IBM in other languages. However, you may be required to own a copy of the product or product version in that language in order to access it.

IBM may not offer the products, services, or features discussed in this document in other countries. Consult your local IBM representative for information on the products and services currently available in your area. Any reference to an IBM product, program, or service is not intended to state or imply that only that IBM product, program, or service may be used. Any functionally equivalent product, program, or service that does not infringe any IBM intellectual property right may be used instead. However, it is the user's responsibility to evaluate and verify the operation of any non-IBM product, program, or service.

IBM may have patents or pending patent applications covering subject matter described in this document. The furnishing of this document does not grant you any license to these patents. You can send license inquiries, in writing, to:

IBM Director of Licensing IBM Corporation North Castle Drive, MD-NC119 Armonk, NY 10504-1785 US

For license inquiries regarding double-byte character set (DBCS) information, contact the IBM Intellectual Property Department in your country or send inquiries, in writing, to:

Intellectual Property Licensing Legal and Intellectual Property Law IBM Japan, Ltd. 19-21, Nihonbashi-Hakozakicho, Chuo-ku Tokyo 103-8510, Japan

INTERNATIONAL BUSINESS MACHINES CORPORATION PROVIDES THIS PUBLICATION "AS IS" WITHOUT WARRANTY OF ANY KIND, EITHER EXPRESS OR IMPLIED, INCLUDING, BUT NOT LIMITED TO, THE IMPLIED WARRANTIES OF NON-INFRINGEMENT, MERCHANTABILITY OR FITNESS FOR A PARTICULAR PURPOSE. Some jurisdictions do not allow disclaimer of express or implied warranties in certain transactions, therefore, this statement may not apply to you.

This information could include technical inaccuracies or typographical errors. Changes are periodically made to the information herein; these changes will be incorporated in new editions of the publication. IBM may make improvements and/or changes in the product(s) and/or the program(s) described in this publication at any time without notice.

Any references in this information to non-IBM websites are provided for convenience only and do not in any manner serve as an endorsement of those websites. The materials at those websites are not part of the materials for this IBM product and use of those websites is at your own risk.

IBM may use or distribute any of the information you provide in any way it believes appropriate without incurring any obligation to you.

Licensees of this program who wish to have information about it for the purpose of enabling: (i) the exchange of information between independently created programs and other programs (including this one) and (ii) the mutual use of the information which has been exchanged, should contact:

IBM Director of Licensing IBM Corporation North Castle Drive, MD-NC119 Armonk, NY 10504-1785 US

Such information may be available, subject to appropriate terms and conditions, including in some cases, payment of a fee.

The licensed program described in this document and all licensed material available for it are provided by IBM under terms of the IBM Customer Agreement, IBM International Program License Agreement or any equivalent agreement between us.

The performance data and client examples cited are presented for illustrative purposes only. Actual performance results may vary depending on specific configurations and operating conditions.

Information concerning non-IBM products was obtained from the suppliers of those products, their published announcements or other publicly available sources. IBM has not tested those products and

cannot confirm the accuracy of performance, compatibility or any other claims related to non-IBM products. Questions on the capabilities of non-IBM products should be addressed to the suppliers of those products.

Statements regarding IBM's future direction or intent are subject to change or withdrawal without notice, and represent goals and objectives only.

This information contains examples of data and reports used in daily business operations. To illustrate them as completely as possible, the examples include the names of individuals, companies, brands, and products. All of these names are fictitious and any similarity to actual people or business enterprises is entirely coincidental.

COPYRIGHT LICENSE:

This information contains sample application programs in source language, which illustrate programming techniques on various operating platforms. You may copy, modify, and distribute these sample programs in any form without payment to IBM, for the purposes of developing, using, marketing or distributing application programs conforming to the application programming interface for the operating platform for which the sample programs are written. These examples have not been thoroughly tested under all conditions. IBM, therefore, cannot guarantee or imply reliability, serviceability, or function of these programs. The sample programs are provided "AS IS", without warranty of any kind. IBM shall not be liable for any damages arising out of your use of the sample programs.

Each copy or any portion of these sample programs or any derivative work must include a copyright notice as follows: © (your company name) (year). Portions of this code are derived from IBM Corp. Sample Programs. © Copyright IBM Corp. _enter the year or years_.

Programming interface information

This information documents Product-sensitive Programming Interface and Associated Guidance Information provided by IMS.

Product-sensitive Programming Interfaces allow the customer installation to perform tasks such as diagnosing, modifying, monitoring, repairing, tailoring, or tuning of this software product. Use of such interfaces creates dependencies on the detailed design or implementation of the IBM software product. Product-sensitive Programming Interfaces should be used only for these specialized purposes. Because of their dependencies on detailed design and implementation, it is to be expected that programs written to such interfaces may need to be changed in order to run with new product releases or versions, or as a result of service. Product-sensitive Programming Interface and Associated Guidance Information is identified where it occurs, either by an introductory statement to a section or topic, or by a Product-sensitive programming interface label. IBM requires that the preceding statement, and any statement in this information that refers to the preceding statement, be included in any whole or partial copy made of the information described by such a statement.

Trademarks

IBM, the IBM logo, and [ibm.com](http://www.ibm.com)® are trademarks or registered trademarks of International Business Machines Corp., registered in many jurisdictions worldwide. Other product and service names might be trademarks of IBM or other companies. A current list of IBM trademarks is available on the web at "Copyright and trademark information" at <http://www.ibm.com/legal/copytrade.shtml>.

Adobe, the Adobe logo, and the PostScript logo are either registered trademarks or trademarks of Adobe Systems Incorporated in the United States, and/or other countries.

Linux® is a registered trademark of Linus Torvalds in the United States, other countries, or both.

Microsoft, Windows, Windows NT, and the Windows logo are trademarks of Microsoft Corporation in the United States, other countries, or both.

Java and all Java-based trademarks and logos are trademarks or registered trademarks of Oracle and/or its affiliates.

UNIX is a registered trademark of The Open Group in the United States and other countries.

Terms and conditions for product documentation

Permissions for the use of these publications are granted subject to the following terms and conditions.

Applicability

These terms and conditions are in addition to any terms of use for the IBM website.

Personal use

You may reproduce these publications for your personal, noncommercial use provided that all proprietary notices are preserved. You may not distribute, display or make derivative work of these publications, or any portion thereof, without the express consent of IBM.

Commercial use

You may reproduce, distribute and display these publications solely within your enterprise provided that all proprietary notices are preserved. You may not make derivative works of these publications, or reproduce, distribute or display these publications or any portion thereof outside your enterprise, without the express consent of IBM.

Rights

Except as expressly granted in this permission, no other permissions, licenses or rights are granted, either express or implied, to the publications or any information, data, software or other intellectual property contained therein.

IBM reserves the right to withdraw the permissions granted herein whenever, in its discretion, the use of the publications is detrimental to its interest or, as determined by IBM, the above instructions are not being properly followed.

You may not download, export or re-export this information except in full compliance with all applicable laws and regulations, including all United States export laws and regulations.

IBM MAKES NO GUARANTEE ABOUT THE CONTENT OF THESE PUBLICATIONS. THE PUBLICATIONS ARE PROVIDED "AS-IS" AND WITHOUT WARRANTY OF ANY KIND, EITHER EXPRESSED OR IMPLIED, INCLUDING BUT NOT LIMITED TO IMPLIED WARRANTIES OF MERCHANTABILITY, NON-INFRINGEMENT, AND FITNESS FOR A PARTICULAR PURPOSE.

IBM Online Privacy Statement

IBM Software products, including software as a service solutions, (“Software Offerings”) may use cookies or other technologies to collect product usage information, to help improve the end user experience, to tailor interactions with the end user or for other purposes. In many cases no personally identifiable information is collected by the Software Offerings. Some of our Software Offerings can help enable you to collect personally identifiable information. If this Software Offering uses cookies to collect personally identifiable information, specific information about this offering’s use of cookies is set forth below.

This Software Offering does not use cookies or other technologies to collect personally identifiable information.

If the configurations deployed for this Software Offering provide you as customer the ability to collect personally identifiable information from end users via cookies and other technologies, you should seek your own legal advice about any laws applicable to such data collection, including any requirements for notice and consent.

To learn more, see [IBM Privacy Statement](#).

Bibliography

This bibliography lists all of the publications in the IMS 15.4 library.

Title	Acronym
<i>IMS Version 15.4 Application Programming</i>	APG
<i>IMS Version 15.4 Application Programming APIs</i>	APR
<i>IMS Version 15.4 Commands, Volume 1: IMS Commands A-M</i>	CR1
<i>IMS Version 15.4 Commands, Volume 2: IMS Commands N-V</i>	CR2
<i>IMS Version 15.4 Commands, Volume 3: IMS Component and z/OS Commands</i>	CR3
<i>IMS Version 15.4 Communications and Connections</i>	CCG
<i>IMS Version 15.4 Database Administration</i>	DAG
<i>IMS Version 15.4 Database Utilities</i>	DUR
<i>IMS Version 15.4 Diagnosis</i>	DGR
<i>IMS Version 15.4 Exit Routines</i>	ERR
<i>IMS Version 15.4 Installation</i>	INS
<i>IMS Version 15.4 Licensed Program Specifications</i>	LPS
<i>IMS Version 15.4 Messages and Codes, Volume 1: DFSMessages</i>	MC1
<i>IMS Version 15.4 Messages and Codes, Volume 2: Non-DFS Messages</i>	MC2
<i>IMS Version 15.4 Messages and Codes, Volume 3: IMSAbend Codes</i>	MC3
<i>IMS Version 15.4 Messages and Codes, Volume 4: IMSComponent Codes</i>	MC4
<i>IMS Version 15.4 Operations and Automation</i>	OAG
<i>IMS Version 15.4 Release Planning</i>	RPG
<i>IMS Version 15.4 System Administration</i>	SAG
<i>IMS Version 15.4 System Definition</i>	SDG
<i>IMS Version 15.4 System Programming APIs</i>	SPR
<i>IMS Version 15.4 System Utilities</i>	SUR

Index

Special Characters

- * (asterisk)
 - BPE trace table type [665](#)
 - CQS trace table type [665](#)
 - OM trace table type [665](#)
 - Repository Server trace table type [665](#)
 - RM trace table type [665](#)
 - SCI trace table type [665](#)
- /DBRECOVERY command
 - preventing for a database that has INDOUBT EEQEs [888](#)
- /DBRECOVERY command, preventing [888](#)
- /DISPLAY POOL PSBP [105](#)
- /START OLDS command [148](#)
- /TRACE
 - IMS Database Recovery Facility, tracing [877](#)

Numerics

- 2305 device [454](#)
- 2740 terminal
 - fast path terminal [471](#)
 - LINEGRP macro statement, specifying [450](#)
 - TERMINAL macro statement, specifying [471](#)
- 2741 terminal
 - LINEGRP macro statement, specifying [450](#)
 - TERMINAL macro statement, specifying [471](#)
- 2780 terminal
 - LINEGRP macro statement, specifying [450](#)
 - TERMINAL macro statement, specifying [471](#)
- 3270 terminal
 - LINEGRP macro statement, specifying [450](#)
 - master terminal devices, choosing [128](#)
 - TERMINAL macro statement, specifying [471](#)
- 3275 terminal
 - LINEGRP macro statement, specifying [450](#)
- 3340 device [453](#)
- 3350 device [453](#)
- 3375 device [453](#)
- 3380 device [453](#)
- 3390 device [453](#)
- 3600 work station [471](#)
- 64-bit storage pool [210](#)

A

- abend search and notification
 - customizing [351](#)
 - DFSDFxxx [777](#)
- abends
 - U3303
 - stopping transactions and PSBs after ten [122](#)
- ABND= parameter [521](#)
- ACB (application control block)
 - ACB management
 - enabling IMS management of ACBs in systems that do not use an IMS catalog [256](#)

- ACB (application control block) (*continued*)
 - ACB management (*continued*)
 - enabling IMS management of ACBs with an existing IMS catalog [254](#)
 - enabling IMS management of ACBs in systems that do not use an IMS catalog [256](#)
 - with an existing IMS catalog [254](#)
 - IMS management of ACBs [252](#)
 - management of ACBs by IMS [252](#)
- ACB generation (ACBGEN)
 - catalog, populating IMS catalog [277](#)
 - IMS catalog, populating [277](#)
- ACB Generation and Populate utility (DFS3UACB)
 - ACBs, adding to the IMS catalog [274](#)
 - catalog, IMS
 - populating [274](#)
 - IMS catalog
 - populating [274](#)
 - populating the IMS catalog [274](#)
- ACB generation utility, PSB pools and [105](#)
- ACBGEN
 - catalog, populating IMS catalog [277](#)
 - IMS catalog, populating [277](#)
- ACBGEN and Catalog Populate utility (DFS3UACB)
 - catalog, IMS
 - adding records to a populated catalog [278](#)
 - load [277](#)
 - catalog, populating IMS catalog [277](#)
 - IMS catalog
 - adding records to a populated catalog [278](#)
 - load [277](#)
 - IMS catalog, populating [277](#)
- ACBLIB
 - 64-bit storage pool [210](#)
 - adding data sets to concatenation [144](#)
 - allocating using DFSMDA [144](#)
 - allocating using JCL [144](#)
 - changing data sets [144](#)
 - defining with DFSMDA member [146](#)
 - defining with IMS procedure [146](#)
 - dynamically allocated [144](#)
 - member online change
 - defining with DFSMDA member [145](#)
 - defining with IMS procedure [145](#)
 - resizing inactive data set [144](#)
- ACBMGMT
 - impact on online regions and environments [261](#)
 - IMS management of ACBs [252](#)
- ACBs
 - IMS management
 - restrictions [252](#)
 - IMS management of and online regions [261](#)
- ACCESS= parameter [416](#)
- accessibility
 - features [xv](#)
 - keyboard shortcuts [xv](#)
- ACF/VTAM terminals

ACF/VTAM terminals (*continued*)
 IMS Extended Terminal Option [214](#)
 ACTIV= parameter [957](#)
 adapter
 names for XML message conversion [895](#)
 ADAPTER
 parameters [918](#)
 statement [918](#)
 syntax [918](#)
 ADDR= parameter [448](#), [461](#)
 address spaces
 CSL
 sequence for starting [247](#)
 AGN= parameter [521](#)
 AL= parameter [966](#)
 ALARM= parameter [836](#)
 ALL type system definition [2](#)
 allocating [150](#)
 allocating communication (MFS) pool space [107](#)
 allocating IMS system data sets
 message queue
 data set [153](#)
 secondary allocation [153](#)
 RECON data set for DBRC [170](#)
 restart data set [153](#)
 allocation
 for HWSRCDR data set [307](#)
 for required libraries [307](#)
 allocation of data sets
 considerations for
 global resource serialization [139](#)
 JES [139](#)
 direct output data sets [169](#)
 extended address volumes [157](#)
 global resource serialization considerations [139](#)
 IMSRSC repository data sets [163](#)
 JES considerations [139](#)
 log data set. [147](#)
 OLDS [147](#)
 OSAM data sets [155](#)
 repository data sets [160](#)
 resource definition data set (RDDS) [158](#)
 RS catalog repository data sets [161](#)
 SLDS [147](#)
 spool SYSOUT [166](#)
 VSAM data sets [156](#)
 WADS [147](#)
 ALOT= parameter [818](#)
 ALOT= parameter for procedures [521](#)
 ALTER option
 IMS catalog considerations [281](#)
 ALTID= parameter for procedures [521](#)
 ALTRESL parameter [973](#)
 AOEXIT= parameter [408](#)
 AOI= parameter [498](#)
 AOI1= parameter for procedures [521](#)
 AOIP= parameter for procedures [522](#)
 AOIS= parameter for procedures [522](#)
 AOS= parameter [736](#)
 APAR= parameter for procedures [522](#)
 APARM= parameter for procedures [522](#)
 APF (authorized program facility)
 specifying in batch procedures [517](#)
 APPC= parameter for procedures [523](#)
 APPCASY= parameter [736](#)
 APPCIOT= parameter [736](#)
 APPCMAXC= parameter [736](#)
 APPCRCV= parameter [736](#)
 APPCEV= parameter for procedures [523](#)
 APPLCTN macro
 CCTL, use with [112](#)
 dynamic reassignment [403](#)
 MSNAME macro, and [406](#)
 ODBA, use with [112](#)
 parameters
 FPATH= [404](#)
 GPSB= [404](#)
 LANG= [405](#)
 PGMTYPE= [405](#)
 PSB= [406](#)
 SCHDTYP= [407](#)
 SYSID= [406](#)
 TRANSACT macro, and [405](#), [406](#)
 APPLCTN macro statement
 for Fast Path [23](#)
 APPLFE= parameter [523](#)
 APPLFE= parameter for procedures [523](#)
 application control block (ACB)
 IMS management of ACBs [252](#)
 management of ACBs by IMS [252](#)
 application control blocks (ACB)
 ACB management
 enabling IMS management of ACBs in systems that do not use an IMS catalog [256](#)
 enabling IMS management of ACBs with an existing IMS catalog [254](#)
 enabling IMS management of ACBs in systems that do not use an IMS catalog [256](#)
 with an existing IMS catalog [254](#)
 application programs
 associated transactions [498](#)
 deleting [72](#)
 deleting dynamically [72](#)
 macros [356](#)
 online applications, defining [112](#)
 scheduling in parallel [124](#)
 APPLID= parameter [408](#)
 APPLID1= parameter for procedures [524](#)
 APPLID2= parameter for procedures [524](#)
 ARC= parameter [187](#)
 ARMRST= parameter for procedures [524](#)
 ASM= parameter [437](#)
 ASMPRT= parameter [437](#)
 ASOT= parameter [819](#), [823](#)
 ASOT= parameter for procedures [525](#)
 ASR option
 changing [461](#)
 displaying [461](#)
 ASSNCHANGE= parameter [736](#)
 asynchronous work element (AWE) [665](#)
 AUDIT_DEFAULT= parameter [911](#)
 AUDIT_FAIL= parameter [911](#)
 AUDIT_ID= parameter [911](#)
 AUDIT_LEVEL= parameter [911](#)
 AUDIT_LOG= parameter [911](#)
 AUDIT= parameter [911](#)
 Audits
 IMS catalog activity record enhancement [294](#)

Audits *(continued)*

- IMS catalog activity records [294](#)
- JVM usage statistics [222](#)
- JVM usage statistics records [223](#)
- AUTHLOG= parameter [736](#)
- authorized program facility (APF)
 - specifying in batch procedures [517](#)
- AUTLCHANGE= parameter [736](#)
- AUTLDESC= parameter [824](#)
- AUTLGN= parameter [824](#)
- AUTLID= parameter [824](#)
- AUTLMOD= parameter [824](#)
- AUTO= parameter [836](#)
- AUTO= parameter for procedures [525](#)
- automatic dump data set allocation [338](#)
- automatic import [85](#), [87](#)
- AUTOSCH option [166](#)
- AWE (asynchronous work element) [665](#)

B

backing out

- changes made with DRD commands [77](#), [78](#)
- MSC changes made with DRD commands [78](#)

BACKUP= parameter [448](#), [450](#), [457](#), [461](#), [471](#), [514](#), [819](#)

Base Primitive Environment (BPE)

- associating exit types with exit routines [684](#)
- configuration member of the IMS PROCLIB data set [245](#)
- defining [242](#)
- entries for z/OS PPT [25](#)
- procedures for CSL [245](#)
- sample configurations [665](#)
- sharing configuration parameters [665](#)
- specify language [665](#)
- specify trace level [665](#)
- traces

- writing to external data sets [665](#)

- tracing processing [665](#)

- user exit member of the IMS PROCLIB data set [245](#)

batch dynamic allocation, disabling [881](#)

batch initialization

- modules that must be loaded [517](#)

BATCH type system definition [2](#)

batching messages [119](#)

BHBUF= parameter [957](#)

BKO= parameter for procedures [525](#)

BLKSIZE= parameter

- DFSMDA TYPE=DFSDCMON statement [421](#)

BMP

- declaring [109](#)

- EXEC parameters [192](#)

BMP regions

- choosing number [103](#)

BMPUSID= parameter [736](#)

BPE (Base Primitive Environment)

- associating exit types with exit routines [684](#)
- configuration member of the IMS PROCLIB data set [245](#)
- configuring [306](#)
- defining [242](#)
- procedures for CSL [245](#)
- sample configurations [665](#)
- sharing configuration parameters [665](#)
- specify language [665](#)
- specify trace level [665](#)

BPE (Base Primitive Environment) *(continued)*

- trace table types [665](#)

- traces

- writing to external data sets [665](#)

- tracing processing [665](#)

- user exit member of the IMS PROCLIB data set [245](#)

BPE configuration member of the IMS PROCLIB data set

- keywords [306](#), [665](#)

- recommendations [665](#)

- specify [665](#)

- specifying [306](#)

BPE exit routine member of the IMS PROCLIB data set

- EXITMBR parameter [665](#)

BPE trace table types

- * (asterisk) [665](#)

- AWE (asynchronous work element) [665](#)

- CBS (control block service) [665](#)

- CMD (command trace table) [665](#)

- DISP (dispatcher trace table) [665](#)

- ERR (error trace table) [665](#)

- HASH (hash trace table) [665](#)

- LATC (latch trace table) [665](#)

- SSRV (system services trace table) [665](#)

- STG (storage service trace table) [665](#)

- USRX (user exit routine trace table) [665](#)

BPECFG= parameter [525](#)

BPECFG= parameter for procedures [525](#)

BPEINI00

- IMS Connect

- authorized supervisor state [297](#)

BPEINIT= parameter for procedures [526](#)

BSIZ= parameter [526](#)

BSIZ= parameter for procedures [526](#)

BUF= parameter [526](#)

BUF= parameter for procedures [526](#)

buffer pool

- defining OSAM subpools [868](#)

- defining VSAM subpools [863](#)

- description of [206](#)

- Fast Path [182](#)

- MFS [108](#)

- OSAM [206](#), [208](#)

- OSAM buffer pool compatibility [208](#)

- OSAM SB [206](#)

- sizes [179](#)

- specifying [206](#)

- VSAM [206](#), [207](#)

buffers

- declaring availability [184](#)

- OSAM

- adjusting [206](#)

- adjusting dynamically [206](#)

- specifying

- in DFSVSMxx member control statement [857](#)

- VSAM

- adjusting [206](#)

- adjusting dynamically [206](#)

BUFFERS= parameter [453](#)

BUFNO= parameter

- DFSMDA TYPE=DFSDCMON statement [421](#)

BUFPOOLS macro

- description [103](#)

- MFS considerations [173](#)

BUFSETS= parameter [957](#)

BUFSIZE= parameter [448](#), [461](#), [471](#)

C

catalog

cloning [291](#), [292](#)

configurations, multi-system [283](#)

copying [291](#), [292](#)

data sharing [284](#)

DFSDFxxx member [283](#)

IMS catalog

allocating data sets [263](#)

allocating database data sets manually [264](#)

data set allocation, manual [264](#)

DBRC [271](#)

definition, overview [249](#)

overview of set up [249](#)

partition definition [271](#)

RECON data set [271](#)

set up, overview [249](#)

size of data sets [266](#)

unregistered HALDB data set [271](#)

IMS-managed ACBs [292](#)

population

ACB generation, during [277](#)

ACBGEN and Catalog Populate utility (DFS3UACB) [277](#)

adding records with the ACBGEN and Catalog

Populate utility (DFS3UACB) [278](#)

adding records with the IMS Catalog Populate utility [280](#)

IMS Catalog Populate utility (DFS3PU00) [279](#)

loading with the IMS Catalog Populate utility [280](#)

updating the IMS catalog [280](#)

RECON data set [283](#)

security [290](#)

system definition

alias [285](#)

data sharing [284](#)

installing DBDs and PSBs [262](#)

multi-system [283](#)

without DBRC [272](#)

unregistered catalog [272](#)

catalog database

data set groups [268](#)

catalog, IMS

ACB management

enabling [254](#)

enabling IMS management of ACBs in systems that do not use an IMS catalog [256](#)

enabling IMS management of ACBs with an existing IMS catalog [254](#)

fallback [259](#)

fallback after resource updates [260](#)

fallback before resource updates [260](#)

ACBs, IMS management of [252](#)

access type

setting [276](#)

ACCESS= parameter [276](#)

CATDBDEF, DFSMDA macro [417](#)

CATDSDLQ, DFSMDA macro [417](#)

data sets

high-level qualifiers [270](#)

DFSDFxxx member

catalog, IMS (continued)

DFSDFxxx member (continued)

multi-system environments [285](#)

DFSMDA macro [417](#)

directory, IMS

definition [252](#)

enabling IMS management of ACBs

in systems that do not use an IMS catalog [256](#)

with an existing IMS catalog [254](#)

examples

multi-system environments [287](#)

high level qualifiers

defining [417](#)

IMS catalog

definition, overview [249](#)

overview of set up [249](#)

set up, overview [249](#)

IMS directory

data sets [269](#)

definition [252](#)

loading

ACB libraries [275](#)

DBD libraries [275](#)

DFSDFxxx [276](#)

PSB libraries [275](#)

required input libraries [275](#)

multi-system environments

DFSDFxxx member [285](#)

examples [287](#)

partition definition data set

dynamic allocation [417](#)

populating

ACB libraries [275](#)

DBD libraries [275](#)

DFSDFxxx [276](#)

PSB libraries [275](#)

required input libraries [275](#)

records

adding [274](#)

inserting [274](#)

loading [274](#)

updating

ACB libraries [275](#)

DBD libraries [275](#)

DFSDFxxx [276](#)

PSB libraries [275](#)

required input libraries [275](#)

utilities

ACB libraries [275](#)

DBD libraries [275](#)

DFSDFxxx [276](#)

population input libraries [275](#)

PSB libraries [275](#)

catalogs

IMS catalog [249](#)

CATDBDEF, DFSMDA macro [417](#)

CATDSDLQ, DFSMDA macro [417](#)

CBS (control block service) [665](#)

CCTVCAN= parameter [526](#)

CCTVCAN= parameter for procedures [526](#)

CCTL

DBCTL databases, and [212](#)

preparing [213](#)

starting [968](#)

CFIRLM= parameter [882](#)
 CFNAMES parameter [882](#)
 CFOSAM= parameter [882](#)
 CFRM (coupling facility resource management)
 policy, defining [242](#)
 CFSizer [237](#)
 CFVSAM= parameter [882](#)
 change list processing
 XRF considerations [44](#)
 change lists
 IMSRSC repository [43](#)
 changing block size
 resource definition data set (RDDS) [159](#)
 channel-end appendages [131](#)
 checkpoint
 data sets [588](#)
 frequency of, setting [103](#)
 CHECKPOINT
 restrictions [465](#)
 CHNGDUMP MAXSPACE
 recommended setting [338](#)
 CICS
 IMS Connect
 RMTICICS configuration statement [938](#)
 ISC TCP/IP support
 RMTICICS configuration statement [938](#)
 CIOP= parameter [527](#)
 CIOP= parameter for procedures [527](#)
 CKPTID= parameter [527](#)
 CKPTID= parameter for procedures [527](#)
 CL1=,CL2=,CL3=,CL4= parameter for procedures [527](#)
 CL1=,CL2=CL3=,CL4= parameters [527](#)
 CLASS= parameter [527](#)
 CLASS= parameter for procedures [527](#)
 client descriptor, OTMA [888](#)
 CMD (command trace table) [665](#)
 CMDLANG= parameter for procedures [527](#)
 CMDMCS= parameter [528](#)
 CMDMCS= parameter for procedures [528](#)
 CMDP= parameter [529](#)
 CMDP= parameter for procedures [529](#)
 CMDSEC= parameter [728](#)
 CMDSEC= parameter for procedures [529](#)
 CNBA= parameter [968](#)
 COBOL
 data conversion
 from XML [303](#)
 XML-to-COBOL conversion support
 configuring [303](#)
 example [303](#)
 prerequisites [303](#)
 restrictions [303](#)
 CODE= parameter [469](#), [498](#)
 cold start
 changing RECLNG [453](#)
 impact on resource definitions [37](#)
 result of not specifying MODBLKS [427](#), [436](#)
 COMM macro
 MFS [173](#)
 parameters
 APPLID= [408](#)
 COPYLOG= [409](#)
 EDTNAME= [410](#)
 FESEXIT= [410](#)
 COMM macro (*continued*)
 parameters (*continued*)
 MFSEXIT= [410](#)
 no longer supported [414](#)
 OPTIONS= [411](#)
 PASSWD= [412](#)
 RECANY= [412](#)
 SECCNT= [414](#)
 SIMEXIT= [414](#)
 syntax diagram [408](#)
 TERMINAL macro, and [414](#)
 VTAM terminals, and [408](#)
 COMM macro statement [361](#)
 command trace table (CMD) [665](#)
 commands
 /CHECKPOINT [103](#)
 /DISPLAY [105](#)
 /START OLDS [148](#)
 /TRACE
 DASD log activity, tracing [876](#)
 DB2 for z/OS subsystem connection, tracing [879](#)
 DBF entries from FP, tracing [876](#)
 dispatcher activity, tracing [875](#)
 DL/I activity, tracing [875](#)
 Fast Path activity, tracing [876](#)
 IMS Database Recovery Facility, tracing [877](#)
 latch activity, tracing [877](#)
 lock activity, tracing [877](#)
 options [875](#)
 OTMA control, tracing [878](#)
 queue manager, tracing [878](#)
 scheduler, tracing [878](#)
 shared queues interface, tracing [878](#)
 storage manager calls, tracing [878](#)
 CREATE TRAN [113](#), [115](#)
 DELETE.LOG DBRC [148](#)
 DFSDFSRT [972](#)
 IMPORT
 backing out changes made with DRD commands [77](#),
 [78](#)
 backing out resources created using IMPORT
 command [90](#), [91](#)
 falling back from using IMSRSC repository [95](#)
 falling back from using IMSRSC repository for
 MODBLKS resources [95](#)
 Common Queue Server (CQS)
 entries for z/OS PPT [25](#)
 Common Service Layer (CSL)
 CSLDCxxx IMS PROCLIB data set member [245](#)
 CSLDIxxx IMS PROCLIB data set member [245](#)
 DFSCGxxx IMS PROCLIB data set member [245](#)
 DFSDFxxx [762](#)
 DFSDFxxx IMS PROCLIB data set member [245](#)
 DFSVSMxx
 CSLT= [875](#)
 entries for z/OS PPT [25](#)
 IMS PROCLIB data set members [245](#)
 load repository server from log records
 startup procedure [599](#)
 Member DFSCGxxx [728](#)
 OM trace table types [665](#)
 Resource Manager
 startup procedure [598](#)

- Common Service Layer (CSL) *(continued)*
 - RM trace table types [665](#)
 - SCI trace table types [665](#)
 - Structured Call Interface
 - startup procedure [598](#)
 - system definition and tailoring [245](#)
- Common Storage Tracker [337](#)
- communication devices
 - defining
 - non-VTAM devices [127](#)
 - VTAM terminals [125](#)
- COMPT= parameter [465](#), [471](#)
- COMPT1= parameter [471](#)
- COMPT2= parameter [471](#)
- COMPT3= parameter [471](#)
- COMPT4= parameter [471](#)
- COMPTn= parameter [819](#)
- configuration
 - alternative IMS online systems [22](#)
 - port id examples [917](#)
- configuration members
 - DATASTORE [917](#)
 - HWS [917](#)
 - IMS Connect
 - ODACCESS statement [917](#)
 - IMSplex [917](#)
- control block service (CBS) [665](#)
- control intervals [546](#)
- control region
 - execution parameters [201](#)
- control statements [957](#)
- converter
 - names for XML message conversion [895](#)
- CONVTYPE= parameter [728](#)
- COPYLOG= parameter [409](#)
- CORE= parameter [529](#)
- CORE= parameter for procedures [529](#)
- coupling facility
 - enabling multiple DEDB areas to share same CF structure [861](#)
 - OSAM data caching [883](#)
 - structure names for Sysplex data sharing [881](#)
- coupling facility resource management (CFRM)
 - policy, defining [242](#)
- CPLOG= parameter [529](#)
- CPLOG= parameter for procedures [529](#)
- CPUTIME= parameter [530](#)
- CPUTIME= parameter for procedures [530](#)
- CQS (Common Queue Server)
 - address space [854](#)
 - customizing [242](#)
 - data sets [590](#)
 - defining [237](#), [242](#)
 - execution data sets
 - structure recovery data set [590](#)
 - system checkpoint data set [590](#)
 - execution parameters
 - specifying [590](#)
 - global structure definition member of the IMS PROCLIB data set
 - keywords [699](#)
 - initialization parameters member of the IMS PROCLIB data set

- CQS (Common Queue Server) *(continued)*
 - initialization parameters member of the IMS PROCLIB data set *(continued)*
 - specifying [692](#)
 - local structure definition PROCLIB member
 - specifying [696](#)
 - LOGR policy [242](#)
 - MAXBUFSIZE [242](#)
 - monitoring [242](#)
 - multiple clients [237](#)
 - parameters
 - CQS PROCLIB [692](#)
 - execution [590](#)
 - resource structure
 - calculating storage for [237](#)
 - set up tracing [345](#)
 - shared queues, placing messages on [574](#)
 - starting [242](#)
 - tailoring [237](#)
- CQS exit routine member of the IMS PROCLIB data set
 - EXITMBR parameter [665](#)
- CQS setup recommendations
 - trace environment
 - conservative [341](#)
 - more aggressive [341](#)
- CQS trace table types
 - * (asterisk) [665](#)
 - CQS (common queue server trace table) [665](#)
 - ERR (error trace table) [665](#)
 - INTF (interface trace table) [665](#)
 - STR (structure trace table) [665](#)
- CQS= parameter [855](#)
- CQSIPxxx
 - defining CSL [245](#)
 - format rules [693](#)
 - overview [692](#)
 - sample member of the IMS PROCLIB data set [695](#)
- CQSSGxxx
 - ELEMENT value [237](#)
 - ENTRY value [237](#)
 - formatting rules [700](#)
 - overview [699](#)
 - sample member of the IMS PROCLIB data set [705](#)
- CQSSLxxx
 - formatting rules [696](#)
 - overview [696](#)
 - sample member of the IMS PROCLIB data set [698](#)
- CQSSSN= parameter [855](#)
- CRC (command recognition character) [427](#)
- CRC= parameter [530](#)
- CRC= parameter for procedures [530](#)
- CREATE TRAN command [113](#), [115](#)
- creating output data sets [345](#)
- CSAPSB= parameter [531](#)
- CSAPSB= parameter for procedures [531](#)
- CSL (Common Service Layer)
 - address spaces
 - sequence for starting [247](#)
 - DFSCGxxx IMS PROCLIB data set member [245](#)
 - DFSDFxxx IMS PROCLIB data set member [245](#)
 - IMS PROCLIB data set members [245](#)
 - OM trace table types [665](#)
 - RM trace table types [665](#)
 - SCI trace table types [665](#)
 - system definition and tailoring [245](#)

CSLDCxxx
 syntax [707](#)
 CSLDCxxx IMS PROCLIB data set member [245](#)
 CSLDCxxx, ODBM configuration member of the IMS PROCLIB data set [706](#)
 CSLDIxxx
 IMS PROCLIB data set member [245](#)
 sample member of the IMS PROCLIB data set [713](#)
 CSLG= parameter [531](#)
 CSLG= parameter for procedures [531](#)
 CSLIPxxx
 validating with Syntax Checker [381](#)
 CSLODBM procedure
 parameters
 ODBMCFG= [558](#)
 ODBMINIT= [558](#)
 ODBMNAME= [558](#)
 CSLOIxxx
 sample member of the IMS PROCLIB data set [716](#)
 validating with Syntax Checker [381](#)
 CSLRIxxx
 validating with Syntax Checker [381](#)
 CSLRM procedure [598](#)
 CSLSGxxx
 validating with Syntax Checker [381](#)
 CSLSIxxx
 validating with Syntax Checker [381](#)
 CSLSLxxx
 validating with Syntax Checker [381](#)
 CSLT= parameter [875](#)
 CSSLIB= parameter for procedures [531](#)
 CTLBLKS type system definition [2](#)

D

DASD
 log tracing [876](#)
 logging [582](#), [584](#), [585](#)
 DASD logging
 OLDS [148](#)
 SLDS [152](#)
 data communication
 EXEC parameters [189](#), [192](#)
 line groups [355](#)
 macro statements [359](#)
 master terminal, specifying [128](#)
 terminals [355](#)
 terminals, defining
 non-VTAM terminals
 [127](#)
 VTAM terminals [125](#)
 Data Definition Language (DDL)
 configuring
 DFSDFxxx member [773](#)
 data set options [773](#)
 defining options
 DFSDFxxx member [773](#)
 DFSDFxxx
 DDL section [773](#)
 data entry databases (DEDBs)
 LKASID value [860](#)
 data set allocation
 considerations for
 global resource serialization [139](#)

data set allocation (*continued*)
 considerations for (*continued*)
 JES [139](#)
 direct output data sets [169](#)
 global resource serialization considerations [139](#)
 JES considerations [139](#)
 log data sets
 OLDS [148](#)
 SLDS [152](#)
 OLDS [147](#)
 OSAM data sets [155](#)
 SLDS [147](#)
 spool SYSOUT data sets
 defining spool line groups [166](#)
 XRF considerations for spool line groups [166](#)
 VSAM data sets [156](#)
 WADS [147](#)
 data sets
 ACBLIB
 allocating [144](#)
 allocating
 extended address volumes [157](#)
 IMS catalog [263](#)
 IMS catalog database, manual allocation [264](#)
 allocation [153](#)
 catalog, IMS
 directory, IMS [269](#), [270](#)
 IMS directory [269](#), [270](#)
 CQS execution [590](#)
 direct output [169](#)
 directory, IMS [269](#)
 entry-sequenced [590](#)
 IMS catalog
 directory high-level qualifier [270](#)
 directory, IMS [269](#)
 IMS directory [269](#)
 IMS directory high-level qualifier [270](#)
 size of data sets [266](#)
 IMS Connect [307](#)
 IMS directory
 high-level qualifier [270](#)
 IMSRSC repository [29](#), [37](#)
 initializing IMS system data sets [139](#), [142](#)
 large sequential data sets
 fallback from [173](#)
 message queue
 restrictions in XRF [153](#)
 OLDS [147](#)
 online [143](#)
 OSAM [155](#)
 output [345](#)
 resource definition [29](#), [37](#)
 size
 IMS catalog [266](#)
 SLDS [147](#)
 structure recovery [590](#)
 SYSOUT [166](#)
 system
 online change function [139](#)
 system checkpoint [590](#)
 WADS [147](#)
 data sharing
 DATABASE macro statement [112](#)
 database-level example [376](#), [377](#)

data sharing (*continued*)
 IMS catalog [284](#)
 IMSCTRL macro statement [112](#)
 inter-CPC block-level example [379](#)
 intra-CPC block-level example [378](#)
 system configuration example [375](#)

data store
 APPL parameter [917](#)
 DRU parameter [917](#)
 GROUP parameter [917](#)
 ID parameter [917](#)
 keyword parameters [917](#)
 MEMBER parameter [917](#)
 RRNAME parameter [917](#)
 TMEMBER parameter [917](#)

database
 buffers, Fast Path [182](#)
 deleting dynamically [71](#)
 deleting with DRD [71](#), [72](#)

Database Control (DBCTL)
 IMS traces
 activating [344](#)
 DL/I [344](#)
 Fast Path [344](#)

database descriptions (DBDs)
 IMS catalog [262](#)

database descriptors (DBDs)
 defining databases
 application control blocks (ACBs), managing [252](#)

DATABASE macro
 description [415](#)
 online applications, defining [112](#)
 parameters
 ACCESS= [416](#)
 DBD= [417](#)
 RESIDENT= [416](#)
 syntax diagram [415](#)

Database Recovery Control utility (DSPURX00)
 catalog, defining [271](#)
 IMS catalog, defining [271](#)

databases
 DBRC, registering with [533](#)
 defining
 application control blocks (ACBs), managing [252](#)
 deleting [71](#)
 DFSDFxxx
 processing options [770](#)
 example [355](#)
 Fast Path [531](#), [539](#)
 HALDB, altering the structure online
 IMS catalog considerations [281](#)
 IBM z/OS Management Facility [236](#)
 macros [356](#)
 main storage (MSDBs) [725](#)
 managing [415](#)
 online, declaring [109](#)

DASTSTORE
 parameters [919](#)
 statement [919](#)
 syntax [919](#)

DB/DC
 enabling subsystem for FDBR [135](#)

DB= parameter [957](#), [964](#), [966](#)

DB2
 DB2 (*continued*)
 subsystem connection, tracing [879](#)
 subsystem identification parameters [177](#)

Db2 for z/OS
 defining to IMS [327](#)
 external subsystem module table [333](#)
 preparing [333](#)
 specifying groups for IMS online regions [331](#)

Db2 for z/OS access
 FSDB2AF DD statement [333](#)
 JBP region, from a
 configuring [333](#)
 JMP region, from a
 configuring [333](#)
 RRSAF [333](#), [334](#)
 RRSAF (Recoverable Resource Manager Services
 attachment facility) [334](#)

DB2 Recoverable Resource Manager Services attachment
 facility [333](#)

DBBBATCH procedure
 description [601](#)
 parameters
 APARM= [522](#)
 BKO= [525](#)
 BUF= [526](#)
 DBRC= [533](#)
 EXCPVR= [540](#)
 FMTO= [541](#)
 IMSID= [545](#)
 IMSPLEX= [546](#)
 IOB= [546](#)
 IRLM= [547](#)
 IRLNM= [547](#)
 LOCKMAX= [550](#)
 LOGA= [551](#)
 LOGT= [551](#)
 MBR= [554](#)
 MON= [555](#)
 PRLD= [565](#)
 PSB= [565](#)
 RGN= [571](#)
 RGSUF= [571](#)
 RST= [572](#)
 SOUT= [575](#)
 SPIE= [576](#)
 SRCH= [576](#)
 SSM= [576](#)
 SWAP= [579](#)
 SYS= [579](#)
 SYS2= [580](#)
 TEST= [580](#)

DBBBATCH procedures
 parameters
 CKPTID= [527](#)
 DBBF= parameter [531](#)
 DBBF= parameter for procedures [531](#)
 DBC (DBCTL online environment)
 procedure for DBCTL [131](#)

DBC procedure
 description [604](#)
 dynamic resource definition [604](#)
 parameters
 AOIP= [522](#)
 ARMRST= [524](#)

DBC procedure (*continued*)

parameters (*continued*)

AUTO= [525](#)
BSIZ= [526](#)
CCTCVCAN= [526](#)
CIOP= [527](#)
CMDMCS= [528](#)
CORE= [529](#)
CRC= [530](#)
CSAPSB= [531](#)
DBBF= [531](#)
DBFP= [532](#)
DBFX= [533](#)
DBRCNM= [534](#)
DBRSE= [534](#)
DBWP= [534](#)
DESC= [536](#)
DFSDF= [536](#)
DLINM= [537](#)
DLIPSB= [537](#)
DMB= [538](#)
DMHVF= [538](#)
EPCB= [539](#)
FDRMBR= [540](#)
FIX= [541](#)
FMTO= [541](#)
FP= [542](#)
FPWP= [543](#)
IMSID= [545](#)
IOB= [546](#)
IRLM= [547](#)
IRLMNM= [547](#)
ISIS= [548](#)
LGNR= [550](#)
MAXPST= [553](#)
MCS= [554](#)
ORSMBR= [559](#)
OTHR= [559](#)
PIINCR= [563](#)
PIMAX= [564](#)
PRDR= [564](#)
PREMSG= [564](#)
PRLD= [565](#)
PSBW= [565](#)
PST= [566](#)
PSWDC= [566](#)
RDMNM= [570](#)
READNUM= [571](#)
RES= [571](#)
RGSUF= [571](#)
SGNGENRC= [574](#)
SPM= [576](#)
SRCH= [576](#)
SSM= [576](#)
SUF= [578](#)
SVC2= [578](#)
UHASH= [581](#)
USERVAR= [582](#)
VSPEC= [582](#)
WKAP= [583](#)
YEAR4= [583](#)

storing [517](#)

DBCTL

CCTL, and [212](#)

DBCTL (*continued*)

enabling subsystem for FDBR [135](#)
environment, example [380](#)
IVP base environment [131](#)
maximum number of BMP and DRA threads [103](#)

DBCTL (Database Control)

IMS traces
activating [344](#)
DL/I [344](#)
Fast Path [344](#)

DBCTLID= parameter [968](#)

DBD= parameter [417](#), [532](#), [726](#), [869](#)

DBD= parameter for procedures [532](#)

DBDs (database descriptions)

IMS catalog [262](#)

DBDs (database descriptors)

defining databases

application control blocks (ACBs), managing [252](#)

DBFMSDBx

description [725](#)

Main Storage Databases, specifying [725](#)

parameters [726](#)

DBFP= parameter [532](#)

DBFP= parameter for procedures [532](#)

DBFX= parameter [533](#)

DBFX= parameter for procedures [533](#)

DBLDL= parameter [533](#)

DBLDL= parameter for procedures [533](#)

DBNAME= parameter

control statements

DFSMDA TYPE=DATABASE [417](#)

DFSMDA TYPE=FPDEDB [417](#)

DFSMDA TYPE=IMSACB [417](#)

DBRC

catalog, defining [271](#)

IMS catalog, defining [271](#)

DBRC (Database Recovery Control)

DATABASE macro, ACCESS parameter [416](#)

initialization parameters member of the IMS PROCLIB

data set [909](#)

initializing the RECON data set [170](#)

procedure

storing [517](#)

user exit list member of the IMS PROCLIB data set [909](#)

DBRC procedure

automatic initiation [609](#)

choosing DBRC parallel processing [609](#)

manual initiation [609](#)

parameters

DBRCNM= [534](#)

DD statements [609](#)

DPRTY= [538](#)

IMSID= [545](#)

IMSPLEX=, description of [546](#)

IMSPLEX=, restriction on using [546](#)

RGN= [571](#)

SOUT= [575](#)

SYS2= [580](#)

PDS member name

DBRCNM= [609](#)

START commands

example [609](#)

starting DBRC in a BPE [609](#)

DBRC= parameter [427](#), [533](#)

DBRC= parameter for procedures [533](#)
 DBRCGRP= parameter [534](#)
 DBRCGRP= parameter for procedures [534](#)
 DBRCINIT= parameter for procedures [534](#)
 DBRCNM= parameter [187](#), [427](#), [534](#)
 DBRCNM= parameter for procedures [534](#)
 DBRSE= parameter [534](#)
 DBRSE= parameter for procedures [534](#)
 DBWP= parameter [534](#)
 DBWP= parameter for procedures [534](#)
 DC= parameter [534](#)
 DC= parameter for procedures [534](#)
 DCC procedure
 description [611](#)
 dynamic resource definition [611](#)
 parameters
 ALOT= [521](#)
 AOIP= [522](#)
 AOIS= [522](#)
 APPC= [523](#)
 APPCSE= [523](#)
 APPLID1= [524](#)
 APPLID2= [524](#)
 ARMRST= [524](#)
 ASOT= [525](#)
 AUTO= [525](#)
 CIOP= [527](#)
 CMDMCS= [528](#)
 CRC= [530](#)
 DC= [534](#)
 DESC= [536](#)
 DFSDF= [536](#)
 DLQT= [537](#)
 DPRTY= [538](#)
 DSCT= [538](#)
 DYNP= [538](#)
 EMHB= [539](#)
 EMHL= [539](#)
 EPCB= [539](#)
 ETO= [540](#)
 EXVR= [540](#)
 FBP= [540](#)
 FESTIM= [541](#)
 FIX= [541](#)
 FMTO= [541](#)
 FRE= [543](#)
 GRNAME= [544](#)
 GRSNAME= [544](#)
 HIOP= [544](#)
 HSBID= [544](#)
 HSBMBR= [545](#)
 IMSID= [545](#)
 ISIS= [548](#)
 LGMSGSZ= [550](#)
 LHTS= [550](#)
 LOGT= [551](#)
 LTERM= [552](#)
 LUMC= [552](#)
 LUMP= [552](#)
 MAXPST= [553](#)
 MCS= [554](#)
 NHTS= [557](#)
 NLXB= [557](#)
 ORSMBR= [559](#)

DCC procedure (*continued*)
 parameters (*continued*)
 OTMA= [559](#)
 OTMANM= [561](#)
 OTMASP= [562](#)
 PASSWD= [562](#)
 PASSWD1= [562](#)
 PRDR= [564](#)
 PRLD= [565](#)
 PSB= [565](#)
 PSBW= [565](#)
 PST= [566](#)
 PSWDC= [566](#)
 QBUF= [567](#)
 QBUFMAX= [567](#)
 QBUSFSZ= [568](#)
 QTL= [568](#)
 QTU= [569](#)
 RCF= [569](#)
 RECA= [571](#)
 RECAZ= [571](#)
 RES= [571](#)
 RGN= [571](#)
 RGSUF= [571](#)
 RVFY= [572](#)
 SAV= [572](#)
 SGN= [573](#)
 SHAREDQ= [574](#)
 SHMSGSZ= [575](#)
 SOD= [575](#)
 SOUT= [575](#)
 SPM= [576](#)
 SRCH= [576](#)
 SSM= [576](#)
 SUF= [578](#)
 SVC2= [578](#)
 SYS= [579](#)
 SYS1= [579](#)
 SYS2= [580](#)
 TRN= [581](#)
 TSR= [581](#)
 UHTS= [581](#)
 USERVAR= [582](#)
 VAUT= [582](#)
 VSPEC= [582](#)
 WKAP= [583](#)
 YEAR4= [583](#)
 storing [517](#)
 DCCTL
 including Fast Path [23](#)
 installing with ETO Feature [131](#)
 DCLWA= parameter [427](#), [498](#)
 DD statements
 DFSDB2AF [333](#)
 INPARMS [587](#)
 MODBLKS [46](#)
 DD= parameter [957](#)
 DDL (Data Definition Language)
 configuring
 DFSDFxxx member [773](#)
 data set options [773](#)
 defining options
 DFSDFxxx member [773](#)
 DFSDFxxx

DDL (Data Definition Language) (*continued*)
 DFSDFxxx (*continued*)
 DDL section [773](#)

DDNAME= keyword
 control statements
 DFSMDA TYPE=DATASET [417](#)
 DFSMDA TYPE=DFSDCMON [417](#)

DDNAME= parameter
 control statements
 DFSMDA TYPE=DFSDCMON [421](#)

DEADLOK= parameter for procedures [535](#)

DEDB (data entry database)
 LKASID value [860](#)
 online utility region parameters [187](#)

DEDBMAS= parameter [861](#)

DEFERFIX= parameter [836](#)

defining
 BPE [242](#)
 CQS [242](#)

defining external subsystems to IMS [327](#)

defining language interface module [329](#)

defining large sequential data sets [171](#)

definition [150](#)

definition process, system
 ALL [2](#)
 BATCH [2](#)
 CTLBLKS [2](#)
 JCLIN process [25](#)
 MODBLKS [2](#)
 MSVERIFY [2](#)
 NUCLEUS [2](#)
 ON-LINE [2](#)
 overview of [1](#)
 SMP/E maintenance [25](#)
 stage 1 [20](#)
 stage 2 [24](#)
 types of [2](#)

DELETE.LOG DBRC command [148](#)

dependent address space procedures [131](#)

dependent regions
 Fast Path parameters [185](#)

DESC= parameter [427](#), [536](#)

DESC= parameter for procedures [536](#)

descriptor definitions
 exporting [79](#)
 importing [84](#), [85](#), [88](#)

descriptors
 client descriptor, OTMA [888](#)
 DFSOTMA descriptor [902](#)
 DFSUSER [217](#)
 ETO
 rules for defining [214](#)
 MFS device [216](#)
 MSC [217](#)
 OTMA
 client descriptor [888](#)
 DFSOTMA descriptor [902](#)
 OTMA destination descriptor [895](#)
 user [217](#)

design limit [395](#)

destination descriptor, OTMA [895](#)

devices
 defining non-VTAM
[127](#)

DFS3314W messages
 removing the limit for the number issued [888](#)

DFS3PU00 utility
 adding records to the IMS catalog [280](#)
 loading the catalog [280](#)
 updating the IMS catalog [280](#)

DFS3UACB utility
 overview [277](#)

DFS62DTx
 description [727](#)
 parameters [728](#)

DFSCGxxx [245](#)

DFSDB2AF DD statement [333](#)

DFSDCxxx
 data communications options, specifying [736](#)
 description [736](#)
 validating with Syntax Checker [381](#)

DFSDF= parameter [536](#)

DFSDF= parameter for procedures [536](#)

DFSDFSRT
 parameters [972](#)
 syntax [972](#)

DFSDFSRT command [972](#)

DFSDFxxx
 catalog section [274](#)
 CATALOG section [756](#)
 Common Service Layer [762](#)
 databases [770](#)
 DDL section [773](#)
 diagnostics and statistics [777](#)
 dynamic database buffer pools
 OSAM [801](#)
 VSAM [810](#)
 dynamic resource definition (DRD) [36](#)
 dynamic resource definitions [179](#), [780](#)
 examples [756](#)
 exit routines [806](#)
 Fast Path 64-bit buffer manager [788](#)
 IMS abend search and notification [777](#)
 IMS catalog section [274](#)
 IMSRSC repository [805](#)
 Logger [794](#)
 MSC section [797](#)
 overview [756](#)
 parameters [756](#)
 sections
 CATALOG [756](#)
 DDL [773](#)
 MSC [797](#)
 shared queues [806](#)
 syntax [756](#)
 validating with Syntax Checker [381](#)

DFSDFxxx member
 ACCESS= parameter [276](#)
 IMS catalog population utilities [276](#)
 population utilities [276](#)

DFSDFRnn
 description [814](#)
 parameters [815](#)

DFSDFSCMx
 ETO descriptors
 common format [816](#)

DFSDFSCTy [827](#)

DFSDFRxx

DFSFDRxx (*continued*)
 description [828](#)
 parameters [828](#)
 DFSFIXnn
 description [830](#)
 DFSHALDB ddname
 selective partition processing [218](#)
 DFSHSBxx
 description [834](#), [839](#)
 parameters [835](#)
 preinitialization routines, specifying dependent region
 [839](#)
 XRF options [834](#)
 DFSIASN0 [619](#)
 DFSIASN0 procedure
 parameters
 APAR= [522](#)
 FMID= [541](#)
 GEN= [543](#)
 IMS= [545](#)
 MOD= [555](#)
 MSG= [556](#)
 RC= [569](#)
 SYSID= [579](#)
 T= [580](#)
 DFSIDEF macro [187](#)
 DFSIDEF0 macro [187](#)
 DFSINTxx
 description [839](#)
 parameters [839](#)
 DFSJBP procedure
 description [621](#)
 parameters
 ENVIRON= [539](#)
 JVMPOPMA= [549](#)
 DFSJMP procedure
 description [623](#)
 parameters
 ENVIRON= [539](#)
 JVMOPWKR= [550](#)
 DFSJVMAP [840](#)
 DFSJVMEV [841](#)
 DFSJVMEV member
 Db2 for z/OS JDBC driver
 [333](#)
 DFSJVMMS
 Db2 for z/OS JDBC driver
 [333](#)
 DFSLI macro [329](#)
 DFSLI000 (language interface module) [329](#)
 DFSMDA (Dynamic Allocation macro)
 allocating ACBLIB data sets [144](#)
 allocating the system log data sets [152](#)
 CATDBDEF [417](#)
 CATDHLQ [417](#)
 definitions [131](#)
 dynamically allocated ACB staging library [145](#)
 dynamically allocated ACBLIB data sets [146](#)
 examples [424](#)
 Fast Path DEDBs [417](#)
 IMS catalog high level qualifier [417](#)
 IMSDALOC procedure [654](#)
 invoking the procedure [654](#)
 JCL requirements [654](#)

DFSMDA (Dynamic Allocation macro) (*continued*)
 logical relationships [427](#)
 monitor data set [417](#)
 multiple DEDBs [417](#)
 OLDS [417](#)
 overview [417](#)
 restrictions [427](#)
 SLDS [417](#)
 statement types
 DATABASE [417](#)
 DATASET [417](#)
 DFSDCMON [417](#)
 FINAL [417](#)
 FPDEDB [417](#)
 IMSACB [417](#)
 INITIAL [417](#)
 OLCSTAT [417](#)
 OLDS [417](#)
 RECON [417](#)
 SLDS [417](#)
 WADS [417](#)
 DFSMPLxx
 description [845](#)
 high-use program modules, making resident [845](#)
 parameters [846](#)
 DFSMPR procedure
 description [626](#)
 IMSMMSG job [657](#)
 parameters
 ALTID= [521](#)
 APARM= [522](#)
 APPLFE= [523](#)
 CL1=,CL2=CL3=,CL4= [527](#)
 DBLDL= [533](#)
 IMSID= [545](#)
 LOCKMAX= [550](#)
 NBA= [556](#)
 OBA= [557](#)
 OPT= [559](#)
 OVLA= [562](#)
 PCB= [563](#)
 PREINIT= [564](#)
 PRLD= [565](#)
 PWF= [566](#)
 RGN= [571](#)
 SOD= [575](#)
 SOUT= [575](#)
 SPIE= [576](#)
 SSM= [576](#)
 STIMER=, message-driven programs [577](#)
 SYS2= [580](#)
 TLIM= [580](#)
 VALCK= [582](#)
 VFREE= [582](#)
 VSFX= [582](#)
 DFSORSxx member [847](#)
 DFSOTMA descriptor [902](#)
 DFSPBDBC
 description [848](#)
 parameters [848](#)
 DFSPBDCC
 description [848](#)
 parameters [848](#)
 DFSPBIMS

DFSPBIMS (*continued*)
 description [848](#)
 parameters [848](#)
 DFSPBxxx
 defining [201](#)
 description [847](#)
 IMS Syntax Checker [201](#)
 sample [201](#)
 updating [201](#)
 validating with Syntax Checker [381](#)
 DFSPRP [968](#)
 DFSPZP00 [968](#)
 DFSRESLB DD statement
 IMS procedures [517](#)
 DFSSPMxx
 description [849](#)
 examples [854](#)
 parameters [853](#)
 DFSSQxxx
 description [854](#)
 parameters [855](#)
 validating with Syntax Checker [381](#)
 DFSSTAT report [584](#)
 DFSURDD0 [95](#)
 DFSUSER [217](#)
 DFSVNUCx module [131](#)
 DFSVSMxx
 /DBRECOVERY command, preventing [888](#)
 control statements, types of [857](#)
 description [857](#)
 discarding preallocated SDEP CIs [887](#)
 Fast Path DEDB buffer pools, defining [860](#), [861](#)
 long busy handling function, enabling [884](#)
 OSAM buffer pools, defining [868](#)
 OSAM subpools, defining [868](#)
 parallel database open, disabling [881](#)
 PPUR= control statement [886](#)
 PSELNODBRC control statement [887](#)
 removing the limit for the number of DFS3314W
 messages issued [888](#)
 resuming an online reorganization for HALDBs [887](#)
 sequential buffering, specifying [871](#)
 serviceability and trace options, defining [871](#)
 VSAM buffer pools, defining [862](#)
 VSAM performance options [866](#)
 VSAM subpools, defining [863](#)
 DFSVSMxxx [245](#)
 DFSYDTx [888](#)
 DIAG (diagnostic) [665](#)
 DIAG= parameter [875](#)
 diagnosis
 IMSabend search and notification [348](#)
 send email about abends [348](#)
 z/OS trace tables
 setting the size [337](#)
 diagnostic (DIAG) [665](#)
 diagnostics
 automatic dump data set allocation [338](#)
 CHNGDUMP MAXSPACE [338](#)
 Common Storage Tracker [337](#)
 IMS Control Region EXEC [339](#)
 setting up IMS for [337](#)
 diagnostics and statistics
 DFSDFxxx [777](#)
 DIRCA= parameter [536](#)
 DIRCA= parameter for procedures [536](#)
 direct output data sets [169](#)
 directory-enabled catalog
 adding GSAM database [261](#)
 directory, IMS
 data sets [269](#)
 definition [252](#)
 high-level qualifier [270](#)
 discarding preallocated SDEP CIs [887](#)
 DISP (dispatcher trace table) [665](#)
 DISP= keyword
 DFSMDA TYPE=DATASET control statement [417](#)
 DISP= parameter [875](#)
 dispatcher trace table (DISP) [665](#)
 DISPLAY command [105](#)
 DL/I
 accounting procedures [105](#)
 call image trace [880](#)
 DLISAS procedure, modifying [106](#)
 execution parameters, system [177](#)
 exits, modifying [106](#)
 lock activity, tracing [877](#)
 security considerations [105](#)
 selecting [105](#)
 starting [106](#)
 storage considerations [105](#)
 tuning considerations [105](#)
 DL/I application programs
 example macro statements [356](#)
 DL/I= parameter [875](#)
 DLIBATCH procedure
 description [628](#)
 parameters
 APARM= [522](#)
 BKO= [525](#)
 BUF= [526](#)
 CKPTID= [527](#)
 DBRC= [533](#)
 EXCPVR= [540](#)
 FMTO= [541](#)
 IMSID= [545](#)
 IMSPLEX= [546](#)
 IOB= [546](#)
 IRLM= [547](#)
 IRLMNM= [547](#)
 LOCKMAX= [550](#)
 LOGA= [551](#)
 LOGT= [551](#)
 MBR= [554](#)
 MON= [555](#)
 PRLD= [565](#)
 RGN= [571](#)
 RGSUF= [571](#)
 RST= [572](#)
 SOUT= [575](#)
 SPIE= [576](#)
 SRCH= [576](#)
 SSM= [576](#)
 SWAP= [579](#)
 SYS2= [580](#)
 TEST= [580](#)
 DLINM= parameter [427](#), [537](#)
 DLINM= parameter for procedures [537](#)

DLIPSB= parameter [537](#)
DLIPSB= parameter for procedures [537](#)
DLISAS
 exit routines in [106](#)
 starting [106](#)
 using [105](#)
DLISAS procedure
 description [631](#)
 parameters
 DPRTY= [538](#)
 IMSID= [545](#)
 RGN= [571](#)
 SOUT= [575](#)
 SYS2= [580](#)
 storing [517](#)
DLOG= parameter [876](#)
DLQT= parameter [537](#)
DLQT= parameter for procedures [537](#)
DMB= parameter [538](#)
DMB= parameter for procedures [538](#)
DMHVF= parameter [538](#)
DMHVF= parameter for procedures [538](#)
DOPT online change [402](#)
DPRTY= parameter [538](#)
DPRTY= parameter for procedures [538](#)
DRA startup table [968](#)
DRD (dynamic resource definition)
 backing out
 changes made with DRD commands [77, 78](#)
 MSC changes made with DRD commands [78](#)
 resources created with IMPORT command [90, 91](#)
 commands that support DRD [33](#)
 commands to manage resource and descriptor definitions [31](#)
 creating
 application program descriptor definitions [55](#)
 application program resource definitions [55](#)
 descriptor definitions [54](#)
 Fast Path routing code definitions [56](#)
 Fast Path routing code descriptor definitions [56](#)
 resource descriptor definitions [53](#)
 resource descriptor definitions in IMSplex [57, 66](#)
 runtime database resources [54](#)
 runtime resource definitions [53](#)
 runtime resource definitions in IMSplex [57, 66, 75](#)
 transaction descriptor definitions [56](#)
 transaction resources [56](#)
 default resource descriptors [31](#)
 deleting
 application programs [72](#)
 database [71](#)
 resource descriptor definitions [69](#)
 resource descriptor definitions in IMSplex [75](#)
 routing codes [73](#)
 runtime resource definitions [69](#)
 transactions [74](#)
 DFSDFxxx [36](#)
 disabling for MODBLKS resources [99](#)
 disabling for MSC resources [101](#)
 enabling
 MSC [52](#)
 exporting
 descriptor definitions [79](#)
 resource definitions [79](#)
 importing
 automatic import function [85, 87](#)
 descriptor definitions [84, 85](#)
 MODBLKS resource definitions [85](#)
 MSC resource definitions [87](#)
 resource definitions [84](#)
 using IMPORT command [84](#)
 IMSRSC repository
 enabling [51](#)
 IMSRSC repository data sets
 allocating [163](#)
 ISPF panels for managing resources [31](#)
 main storage databases [54](#)
 maintaining DRD environment [91](#)
 manage resources from ISPF panels [31](#)
 MODBLKS
 enabling [49](#)
 preparing to enable [49](#)
 MSC
 enabling [52](#)
 overview [29](#)
 RDDS
 enabling [50](#)
 repository data sets
 allocating [160](#)
 requirements
 MODBLKS [44](#)
 resource definition data set (RDDS)
 allocating [158](#)
 restrictions [45](#)
 RS catalog repository data sets
 allocating [161](#)
 updating
 application program descriptor definitions [63](#)
 application program resources [63](#)
 database resources [62](#)
 descriptor definitions [62](#)
 Fast Path routing code descriptor definitions [64](#)
 Fast Path routing code resource definitions [64](#)
 resource descriptor definitions [61](#)
 runtime resource definitions [61](#)
 transaction descriptor definitions [65](#)
 transaction resource definitions [65](#)
DREF storage, defining [814](#)
DSCT= parameter [538](#)
DSCT= parameter for procedures [538](#)
DSETS= parameter [453](#)
DSNAME= data set
 control statements
 DFSMDA TYPE=DATASET [417](#)
 DFSMDA TYPE=DFSDCMON [420](#)
DSNAME= parameter [968](#)
DSPBIxxx
 sample member of the IMS PROCLIB data set [909](#)
dump
 system execution parameters [177](#)
DUMP= parameter [876](#)
DUMPIO= parameter [876](#)
DXRJPROC procedure
 description [633](#)
 parameters
 DEADLOK= [535](#)
dynamic allocation

dynamic allocation (*continued*)
 ACBLIB data sets [146](#)
 terminals [132](#)
 using extended storage [871](#)

Dynamic Allocation macro (DFSMDA)
 CATDBDEF [417](#)
 CATDShLQ [417](#)
 examples [424](#)
 Fast Path DEDBs [417](#)
 IMSDALOC procedure [654](#)
 invoking the procedure [654](#)
 JCL requirements [654](#)
 logical relationships [427](#)
 monitor data set [417](#)
 multiple DEDBs [417](#)
 OLDS [417](#)
 restrictions [427](#)
 SLDS [417](#)
 statement types
 DATABASE [417](#)
 DATASET [417](#)
 DFSDCMON [417](#)
 FINAL [417](#)
 FPDEDB [417](#)
 IMSACB [417](#)
 INITIAL [417](#)
 OLCSTAT [417](#)
 OLDS [417](#)
 RECON [417](#)
 SLDS [417](#)
 WADS [417](#)

dynamic buffer pool definition
 OSAM [208](#)

dynamic database buffer pool definition
 OSAM [209](#)
 VSAM [207](#), [209](#)

dynamic database buffer pools
 adjusting for OSAM [206](#)
 adjusting for VSAM [206](#)
 OSAM
 DFSDFxxx [801](#)
 VSAM
 DFSDFxxx [810](#)

dynamic definition
 enabling
 MSC [52](#)
 MSC
 enabling [52](#)

dynamic PSB [109](#)

dynamic reassignment and APPLCTN macro [403](#)

dynamic resource definition (DRD)
 backing out
 changes made with DRD commands [77](#), [78](#)
 MSC changes made with DRD commands [78](#)
 resources created with IMPORT command [90](#), [91](#)
 commands that support DRD [33](#)
 commands to manage resource and descriptor definitions [31](#)
 creating
 application program descriptor definitions [55](#)
 application program resource definitions [55](#)
 descriptor definitions [54](#)
 Fast Path routing code definitions [56](#)
 Fast Path routing code descriptor definitions [56](#)

dynamic resource definition (DRD) (*continued*)
 creating (*continued*)
 resource descriptor definitions [53](#)
 resource descriptor definitions in IMSplex [57](#)
 runtime database resources [54](#)
 runtime resource definitions [53](#)
 runtime resource definitions in IMSplex [57](#), [66](#)
 transaction descriptor definitions [56](#)
 transaction resources [56](#)

DBC procedure [604](#)
 DCC procedure [611](#)
 default resource descriptors [31](#)
 deleting
 application programs [72](#)
 database [71](#)
 resource descriptor definitions [69](#)
 resource descriptor definitions in IMSplex [75](#)
 routing codes [73](#)
 runtime resource definitions [69](#)
 runtime resource definitions in IMSplex [75](#)
 transactions [74](#)

DFSDFxxx [36](#), [179](#), [780](#)
 disabling [99](#), [101](#)
 enable automatic export [91](#)
 enable automatic import [91](#)
 enabling
 MSC [52](#)

exporting
 descriptor definitions [79](#)
 resource definitions [79](#)

importing
 automatic import function [85](#), [87](#)
 descriptor definitions [84](#), [85](#)
 MODBLKS resource definitions [85](#)
 MSC resource definitions [87](#)
 resource definitions [84](#)
 using IMPORT command [84](#)

IMSRSC repository
 enabling [51](#)

IMSRSC repository data sets
 allocating [163](#)

ISPF panels for managing resources [31](#)
 main storage databases [54](#)
 maintaining DRD environment [91](#)
 manage resources from ISPF panels [31](#)

MODBLKS
 enabling [49](#)
 preparing to enable [49](#)

MSC
 enabling [52](#)

overview [29](#)

RDDS
 enabling [50](#)
 remove IMS.MODBLKS [91](#)
 repository data sets
 allocating [160](#)
 requirements [44](#)
 resource definition data set (RDDS)
 allocating [158](#)
 restrictions [45](#)

RS catalog repository data sets
 allocating [161](#)

synchronize MODBLKS and RDDS [91](#)
 updating

dynamic resource definition (DRD) (*continued*)
 updating (*continued*)
 application program descriptor definitions [63](#)
 application program resources [63](#)
 database resources [62](#)
 descriptor definitions [62](#)
 Fast Path routing code descriptor definitions [64](#)
 Fast Path routing code resource definitions [64](#)
 resource descriptor definitions [61](#)
 resource descriptor definitions in IMSplex [66](#)
 runtime resource definitions [61](#)
 transaction descriptor definitions [65](#)
 transaction resource definitions [65](#)
DYNP= parameter [538](#)
DYNP= parameter for procedures [538](#)

E

ECB (Even Control Block) [917](#)
ECSA (extended common storage area) [182](#)
EDIT= parameter [450](#), [465](#), [471](#), [498](#), [514](#), [819](#)
EDTNAME= parameter [410](#)
emergency restart
 resuming an online reorganization for HALDBs [887](#)
EMHB= parameter [539](#)
EMHB= parameter for procedures [539](#)
EMHL= parameter [539](#)
EMHL= parameter for procedures [539](#)
EMHQ (EMH queue)
 disabling [699](#)
EMHQ (EMH queue) structures
 disabling [697](#)
enhancements
 IMS catalog activity record enhancement [294](#)
 JVM usage statistics [222](#)
enqueue/dequeue tables
 allocation, changing [136](#)
 specifying [136](#)
 system definition, in [136](#)
entry sequenced data set (ESDS) [590](#)
ENVIRON= parameter [539](#)
ENVIRON= parameter for procedures [539](#)
EPCB= parameter [539](#)
EPCB= parameter for procedures [539](#)
ERPKPSES= parameter [736](#)
ERPL (error parameter list trace table) [665](#)
ERR (error trace table)
 BPE trace table type [665](#)
 CQS trace table type [665](#)
 OM trace table type [665](#)
 RM trace table type [665](#)
 SCI trace table type [665](#)
error parameter list trace table (ERPL) [665](#)
error trace table (ERR)
 BPE trace table type [665](#)
 CQS trace table type [665](#)
 OM trace table type [665](#)
 RM trace table type [665](#)
 SCI trace table type [665](#)
ESAF (external subsystem attach facility) [333](#)
ESDS (entry sequenced data set) [590](#)
ETO
 descriptors
 format [214](#)

ETO (*continued*)
 descriptors (*continued*)
 logon [215](#)
 MFS device [216](#)
 MSC [217](#)
 overrides [215](#)
 statements, common format [816](#)
 user [217](#)
 DFSDSCMx PROCLIB member [815](#)
 DFSDSCTy PROCLIB member [827](#)
 IMSCTRL macro [214](#)
 IMSCTRL macro, ETOFEAT [427](#)
 including in IMS [214](#)
 keyword rules [214](#)
 PROCLIB member DFSDSCMx [815](#)
 PROCLIB member DFSDSCTy [827](#)
 terminal naming rules [395](#)
ETO (Extended Terminal Option)
 descriptors
 MFS [821](#)
 MFS devices
 descriptors [821](#)
ETO (Extended Terminal Option)
 descriptors
 MSC [822](#)
 logon
 descriptor format [817](#)
 MSC (Multiple Systems Coupling)
 descriptor format [822](#)
 user descriptors
 format [823](#)
ETO= parameter [540](#)
ETO= parameter for procedures [540](#)
ETOFEAT= parameter [427](#)
EVAL= parameter [957](#)
examples
 coding conventions [395](#)
 CQSIPIxxx member of the IMS PROCLIB data set [695](#)
 CQSSGxxx member of the IMS PROCLIB data set [705](#)
 CQSSLxxx sample member of the IMS PROCLIB data set [698](#)
 data sharing [376–379](#)
 data sharing system configuration [375](#)
 DL/I application program macro statements [356](#)
 Dynamic Allocation macro [424](#)
 IMS DB/DC system definition [355](#)
 IMS DBCTL environment [380](#)
 MSC [371](#)
 OBJAVGSZ calculation [702](#)
 RSRCSTRUCTURE= parameter [704](#)
 SSN= parameter [695](#)
 startup procedures [590](#)
 structure recovery data set [590](#)
 system checkpoint data set [590](#)
 system definition [355](#)
 transaction grouping [117](#)
exclusive access to databases [416](#)
exclusive intent
 with scheduling algorithm [124](#)
EXCPVR= parameter [540](#)
EXCPVR= parameter for procedures [540](#)
EXEC statement parameters
 Fast Path [182](#)
executing online utilities [201](#)

- execution parameters
 - categories and purpose [192](#)
 - data communication [189](#), [192](#)
 - database [179](#)
 - database performance options [180](#)
 - db buffer sizes [179](#)
 - performance-related [189](#)
 - PSB-related [192](#)
 - PSBs [179](#)
 - recovery-related [187](#), [189](#), [192](#)
 - region control [189](#), [192](#)
 - security-related [189](#), [192](#)
 - specifying [177](#)
 - system
 - active regions [177](#)
 - DL/I address space [177](#)
 - IRLM options [177](#)
 - nucleus identifier [177](#)
 - performance options [177](#)
 - z/OS options [177](#)
 - TM buffer sizes [180](#)
 - TM performance options [180](#)
- execution procedures, tailoring
 - for Fast Path [201](#)
- exit routines
 - DFSDFxxx [806](#)
 - preprocessor [19](#)
 - running in DLISAS [106](#)
- EXITDEF statement
 - BPE types [684](#)
 - CQS types [684](#)
 - IMS Connect types [684](#)
 - keywords [684](#)
 - OM types [684](#)
 - RM types [684](#)
 - SCI types [684](#)
- EXITMBR parameter
 - BPE exit routine member of the IMS PROCLIB data set [665](#)
 - CQS exit routine member of the IMS PROCLIB data set [665](#)
 - HWS exit member of the IMS PROCLIB data set [665](#)
 - ims_component [665](#)
 - member_name [665](#)
 - OM exit routine member of the IMS PROCLIB data set [665](#)
 - RM exit routine member of the IMS PROCLIB data set [665](#)
 - SCI exit routine member of the IMS PROCLIB data set [665](#)
- extended address volumes
 - allocating data sets [157](#)
- extended common storage area (ECSA) [182](#)
- extended storage
 - requesting that z/OS use [871](#)
- Extended Terminal Option (ETO)
 - descriptors
 - MFS device [821](#)
 - MSC [822](#)
 - logon
 - descriptor format [817](#)
 - MFS devices
 - descriptors [821](#)
- Extended Terminal Option (ETO) (*continued*)
 - MSC (Multiple Systems Coupling)
 - descriptor format [822](#)
 - user descriptors
 - format [823](#)
 - external subsystem
 - module placement [333](#)
 - table placement [333](#)
 - external subsystem attach facility
 - adding an SSM member to the IMS PROCLIB data set [327](#)
 - defining external subsystems to IMS [327](#)
 - defining language interface module [329](#)
 - DFSLI macro [329](#)
 - IMS.PROCLIB, description [327](#)
 - language interface token [329](#)
 - OPTIONS statement [330](#)
 - specifying Db2 for z/OS groups [331](#)
 - specifying trace options [330](#)
 - SSM= EXEC parameter [328](#)
 - SUBS= parameter [330](#)
 - external subsystem attach facility (ESAF) [333](#)
 - external subsystem module table [333](#)
 - external trace environment [343](#)
 - EXVR= parameter [540](#)
 - EXVR= parameter for procedures [540](#)

F

- F= parameter [726](#)
- fallback
 - large sequential data sets [173](#)
- Fast Path
 - and DBCTL system definition [24](#)
 - BMP region parameters [186](#)
 - buffer manager [23](#)
 - buffers [24](#), [182](#)
 - CCTL region parameters [186](#)
 - control region EXEC statement parameters [182](#), [184](#)
 - database buffers [182](#)
 - DBF trace entries [876](#)
 - declaring application programs [113](#)
 - declaring program processing [113](#)
 - DEDB buffers pools, defining [860](#), [861](#)
 - defining a buffer manager [23](#)
 - defining the system [23](#)
 - defining transaction characteristics [115](#)
 - dependent regions
 - parameters [185](#)
 - execution procedures [201](#)
 - IMSFP procedure [656](#)
 - including in DCCTL [23](#)
 - macro statements
 - APPLCTN [404](#), [405](#)
 - DATABASE [415](#)
 - FPCTRL [427](#)
 - required macros [23](#)
 - routing codes, adding [113](#)
 - system definition and [23](#)
 - terminals
 - 2740 terminal [471](#)
 - traces [344](#)
- Fast Path 64-bit buffer manager
 - DFSDFxxx [788](#)

FAST= parameter [876](#)
FBP= parameter [540](#)
FBP= parameter for procedures [540](#)
FDBR (Fast Database Recovery)
 DB/DC [135](#)
 DBCTL [135](#)
 defining [133](#)
 enabling [135](#)
 enabling DB/DC subsystem for [135](#)
 enabling DBCTL subsystem for [135](#)
 IMS PROCLIB data set member, create [133](#)
 MODBLKS DD statement [46](#)
 regions
 configuration [134](#)
 requirements
 IMSplex [136](#)
 support for IMSRSC repository [37](#)
 support for RDDS [37](#)
FDR procedure
 description [634](#)
 parameters
 ARMRST= [524](#), [526](#)
 BSIZ= [526](#)
 CSAPSB= [531](#)
 CSLG= [531](#)
 DBBF= [531](#)
 DBWP= [534](#)
 DESC= [536](#)
 DFRMBR= [540](#)
 DLIPSB= [537](#)
 DMB= [538](#)
 DPRTY= [538](#)
 FMTO= [541](#)
 IMSID= [545](#)
 IMSPLEX= [546](#)
 IRLMNM= [547](#)
 LGNR= [550](#)
 MCS= [554](#)
 PSB= [565](#)
 PSBW= [565](#)
 RGN= [571](#)
 RGSUF= [571](#)
 SOUT= [575](#)
 SPM= [576](#)
 SUF= [578](#)
 SVC2= [578](#)
 SYS1= [579](#)
 SYS2= [580](#)
 UHASH= [581](#)
 VSPEC= [582](#)
 WKAP= [583](#)
FDRMBR= parameter [540](#)
FDRMBR= parameter for procedures [540](#)
FEAT= parameter [450](#), [471](#), [819](#)
FES exit routine [410](#)
FESEXIT= parameter [410](#)
FESEXIT= parameter for procedures [540](#)
FESTIM= parameter [541](#)
FESTIM= parameter for procedures [541](#)
Field Edit exit routine [410](#)
finance communication system [364](#)
Finance work station [471](#)
FIX= parameter [541](#)
FIX= parameter for procedures [541](#)

FIXBLOCK= parameter [863](#)
FIXDATA= parameter [863](#)
FIXINDEX= parameter [863](#)
FMID= parameter [541](#)
FMID= parameter for procedures [541](#)
FMTO option
 specify FMTO option [339](#)
FMTO= parameter [541](#)
FMTO= parameter for procedures [541](#)
FMTO=D parameter value [339](#)
forms control
 vertical [471](#)
FP= parameter [542](#)
FP= parameter for procedures [542](#)
FPATH keyword on APPLCTN macro [113](#)
FPATH= parameter [404](#), [498](#)
FPBOF= parameter [968](#)
FPBP64U= parameter [966](#)
FPBUF= parameter [471](#), [968](#)
FPCTRL
 description [427](#)
FPOPN= parameter [542](#)
FPOPN= parameter for procedures [542](#)
FPRLM= parameter [543](#)
FPRLM= parameter for procedures [543](#)
FPTT= parameter [876](#)
FPUTIL procedure
 description [638](#)
 parameters
 ALTID= [521](#)
 DBD= [532](#)
 DIRCA= [536](#)
 IMSID= [545](#)
 PRLD= [565](#)
 REST= [571](#)
 RGN= [571](#)
 SOUT= [575](#)
 SSM= [576](#)
 SYS2 [580](#)
FPWP= parameter [543](#)
FPWP= parameter for procedures [543](#)
FRE= parameter [543](#)
FRE= parameter for procedures [543](#)
FREs
 controlling [107](#)
 estimating [107](#)
 MFS, and [108](#)
FRPCFG
 description [911](#)
 validating with Syntax Checker [381](#)
FUNCLV= parameter [968](#)

G

GEN= parameter [543](#)
GEN= parameter for procedures [543](#)
generic resources
 MSC TCP/IP
 enabling [318](#)
GENSNAP= parameter [968](#)
GPSB= parameter [404](#)
GRAFFIN= parameter [736](#)
GRESTAE= parameter [736](#)
GRMESTAE= parameter [736](#)

GRNAME= parameter [544](#)
GRNAME= parameter for procedures [544](#)
GRSNAME= parameter [544](#)
GRSNAME= parameter for procedures [544](#)
GSAM databases
 adding to directory-enabled IMS catalog [261](#)

H

HALDB
 altering the structure of an online databases
 IMS catalog considerations [281](#)
 changing the structure of an online databases
 IMS catalog considerations [281](#)
 DFSHALDB ddname [218](#)
 HALDB control statement [218](#)
 modifying the structure of an online databases
 IMS catalog considerations [281](#)
 partitions
 selective partition processing [218](#)
 selective partition processing [218](#)
HALDB control statement [218](#)
HALDB partition
 system definition types
 ALL [5](#)
 MODBLKS [5](#)
HALDBs
 master database
 deleting dynamically [71](#)
 resuming an online reorganization during emergency
 restart [887](#)
 resuming an online reorganization during warm start
 [887](#)
hang condition [917](#)
HASH (hash trace table) [665](#)
hash table slots, specifying [218](#)
hash trace table (HASH) [665](#)
HIDAM databases
 declaring [109](#)
 macro instructions [415](#)
High Availability Large Database (HALDB) partition
 system definition types
 ALL [5](#)
 MODBLKS [5](#)
high-speed sequential control statements, specifying
 examples [966](#)
 SETO [964](#)
 SETR [966](#)
 SETU [966](#)
 syntax [964](#)
high-speed sequential processing
 control statements [212](#)
high-use program modules, making resident with DFSMPLxx
[845](#)
HIOP= parameter [544](#)
HIOP= parameter for procedures [544](#)
HLQ parameter [973](#)
HSB= parameter [427](#)
HSBID= parameter [544](#)
HSBID= parameter for procedures [544](#)
HSBMBR= parameter [545](#)
HSBMBR= parameter for procedures [545](#)
HSn= parameter [864](#)
HSSP

HSSP (*continued*)
 control statements [212](#)
HWS
 CM0ATOQ parameter [917](#)
 KEEPAV parameter [917](#)
 keyword parameters [917](#)
 parameters [923](#)
 statement [923](#)
 syntax [923](#)
 WARNINC parameter [917](#)
 WARNSOC parameter [917](#)
HWS exit routine member of the IMS PROCLIB data set
 EXITMBR parameter [665](#)
HWSCFGxx
 configuration
 examples [949](#)
 examples
 CICS [952](#)
 IMS DB support [953](#)
 ISC [952](#)
 Open Database [953](#)
 Universal driver support [953](#)
HWSSOAP1 [303](#)
HWSUINIT
 and user message exits [917](#)
 restrictions for EXIT= parameter [917](#)

I

IBM z/OS Management Facility (z/
 OSMF)
 DEDB database [236](#)
 Fast Path DEDB [236](#)
 IMS system [235](#)
 provision
 DEDB database [236](#)
 IMS system [235](#)
IC= parameter [965](#), [967](#)
ICOMPT= parameter [465](#)
ICON_NAME
 and security configuration [300](#)
IDCO= parameter [876](#)
IDLE command [465](#)
IEBGENER [344](#)
IEBGENER utility [166](#)
IEFBR14 utility [155](#)
ILDS (Indirect List Data Set) [171](#)
ILE (Indirect List Entry) [171](#)
IMPORT
 backing out changes made with DRD commands [77](#), [78](#)
 backing out resources created using IMPORT command
 [90](#), [91](#)
 falling back from using IMSRSC repository [95](#)
 falling back from using IMSRSC repository for MODBLKS
 resources [95](#)
IMPORT command [84](#), [88](#)
IMS
 DB/DC [131](#)
 designing [103](#)
 procedure for IMS [131](#)
 solutions for Java
 IMS PROCLIB data set members [844](#)
 PROCLIB data set members [840](#)
IMS abend search and notification

IMS abend search and notification *(continued)*

setting up [348](#)

IMS catalog

ACB generation (ACBGEN)

populating the catalog during ACBGEN [277](#)

ACB management

enabling [254](#)

enabling IMS management of ACBs in systems that do not use an IMS catalog [256](#)

enabling IMS management of ACBs with an existing IMS catalog [254](#)

fallback [259](#)

fallback after resource updates [260](#)

fallback before resource updates [260](#)

ACBGEN

populating the catalog during ACBGEN [277](#)

ACBs, IMS management of [252](#)

access type

setting [276](#)

ACCESS= parameter [276](#)

allocating data sets [263](#)

allocating database data sets manually [264](#)

CATDBDEF, DFSMDA macro [417](#)

CATDHLQ, DFSMDA macro [417](#)

cloning [291](#), [292](#)

configurations, multi-system [283](#)

copying [291](#), [292](#)

data set allocation, manual [264](#)

data set groups [268](#)

data sets

directory, IMS [269](#)

high-level qualifiers [270](#)

IMS directory [269](#)

staging [269](#)

data sharing [284](#)

DBDs for the IMS catalog [262](#)

DBRC [271](#)

DBRC, defining to [271](#)

definition, overview [249](#)

DFSDFxxx

CATALOG [756](#)

DFSDFxxx member

multi-system environments [285](#)

DFSDFxxx, section in [274](#)

DFSMDA macro [417](#)

directory, IMS

definition [252](#)

enabling IMS management of ACBs

in systems that do not use an IMS catalog [256](#)

with an existing IMS catalog [254](#)

examples

multi-system environments [287](#)

high level qualifiers

defining [417](#)

IMS directory

data sets [269](#)

definition [252](#)

IMS-managed ACBs [292](#)

loading

ACB libraries [275](#)

DBD libraries [275](#)

DFSDFxxx [276](#)

PSB libraries [275](#)

required input libraries [275](#)

IMS catalog *(continued)*

multi-system environments

DFSDFxxx member [285](#)

examples [287](#)

overview of set up [249](#)

partition definition [271](#)

populating

ACB libraries [275](#)

DBD libraries [275](#)

DFSDFxxx [276](#)

PSB libraries [275](#)

required input libraries [275](#)

population

ACB generation, during [277](#)

ACBGEN and Catalog Populate utility (DFS3UACB) [277](#)

adding records with the ACBGEN and Catalog Populate utility (DFS3UACB) [278](#)

adding records with the IMS Catalog Populate utility [280](#)

IMS Catalog Populate utility (DFS3PU00) [279](#)

loading with the IMS Catalog Populate utility [280](#)

updating the IMS catalog [280](#)

PSBs (program specification blocks) [274](#)

PSBs for the IMS catalog [262](#)

RECON data set [271](#), [283](#)

records

adding [274](#)

inserting [274](#)

loading [274](#)

security [290](#)

set up, overview [249](#)

size of data sets [266](#)

system definition

alias [285](#)

data sharing [284](#)

installing DBDs and PSBs [262](#)

multi-system [283](#)

without DBRC [272](#)

unregistered catalog [272](#)

unregistered HALDB data set [271](#)

updating

ACB libraries [275](#)

DBD libraries [275](#)

DFSDFxxx [276](#)

PSB libraries [275](#)

required input libraries [275](#)

utilities

ACB libraries [275](#)

DBD libraries [275](#)

DFSDFxxx [276](#)

PSB libraries [275](#)

required input libraries [275](#)

IMS catalog activity record enhancement [294](#)

IMS catalog activity records [294](#)

IMS Catalog Copy utility (DFS3CCE0, DFS3CCIO)

steps for copying an IMS catalog [291](#)

steps for copying an IMS catalog that does not contain IMS-managed ACBs [291](#)

steps for copying an IMS catalog with IMS-managed ACBs [292](#)

IMS Catalog Populate utility

adding records to an IMS catalog [280](#)

load mode [280](#)

- IMS Catalog Populate utility (*continued*)
 - updating the IMS catalog [280](#)
- IMS Catalog Populate utility (DFS3PU00)
 - ACBs, adding to the IMS catalog [274](#)
 - catalog, IMS
 - populating [274](#)
 - catalog, populating IMS catalog [279](#)
 - IMS catalog
 - populating [274](#)
 - IMS catalog, populating [279](#)
 - populating the IMS catalog [274](#)
- IMS Connect
 - authorized supervisor state [297](#)
 - BPEINI00 [297](#)
 - CICS
 - configuration example [952](#)
 - configuration
 - CICS example [952](#)
 - examples [949](#)
 - IMS DB support example [953](#)
 - ISC example [952](#)
 - Open Database example [953](#)
 - Universal driver support example [953](#)
 - configuration members [917](#)
 - configuration statement parameters [917](#)
 - configuration statement syntax [917](#)
 - configuration statements
 - ADAPTER [918](#)
 - DATASTORE [919](#)
 - HWS [923](#)
 - IMSPLEX [928](#)
 - ISC [929](#)
 - MSC [932](#)
 - ODACCESS [934](#)
 - RMTCICS [938](#)
 - RMTIMSCON [939](#)
 - TCPIP [943](#)
 - connections between IMS systems, defining [311](#)
 - definition and tailoring [297](#)
 - DRDAPORT parameter [917](#)
 - entries for z/OS PPT [25](#)
 - environment [297](#)
 - examples
 - configuration statements for IMS-to-IMS connections [952](#)
 - IMS-to-IMS TCP/IP communications [311](#)
 - in IMSplex environment [297](#)
 - invoking [297](#)
 - ISC
 - configuration example [952](#)
 - ISC configuration statement [929](#)
 - ODBM access configuration parameters [917](#)
 - ODBAUTOCONN parameter [917](#)
 - Open Database
 - configuration example [953](#)
 - RMTCICS configuration statement [938](#)
 - sample configurations [917](#)
 - sample user exit list member of the IMS PROCLIB data set [684](#)
 - security for [300](#)
 - set up tracing [345](#)
 - SSL
 - IMS Connect [300](#)
 - system definition

- IMS Connect (*continued*)
 - system definition (*continued*)
 - IMS-to-IMS TCP/IP connections [311](#)
 - trace tables
 - CMDT [665](#)
 - ENVT [665](#)
 - ERRV [665](#)
 - HWSI [665](#)
 - HWSN [665](#)
 - HWSO [665](#)
 - HWSW [665](#)
 - OMDR [665](#)
 - OTMA [665](#)
 - PCDR [665](#)
 - RCTR [665](#)
 - TCPI [665](#)
 - Universal drivers
 - configuration example [953](#)
 - XML conversion support [303](#)
 - XML-to-COBOL conversion support
 - configuring [303](#)
 - example [303](#)
 - prerequisites [303](#)
 - restrictions [303](#)
 - XML-to-PL/I conversion support
 - configuring [303](#)
 - example [303](#)
 - prerequisites [303](#)
 - restrictions [303](#)
- IMS control region
 - entries for z/OS PPT [25](#)
- IMS Database Recovery Facility
 - activating trace for [877](#)
 - tracing activity [877](#)
- IMS directory
 - data sets [269](#)
 - definition [252](#)
 - high-level qualifier [270](#)
- IMS dump formatter [972](#)
- IMS Dump Formatter
 - DD concatenations to update [342](#)
 - installing [342](#)
- IMS Extended Terminal Option Support
 - ACF/VTAM terminals [214](#)
 - including in IMS [132](#)
- IMS management of ACBs
 - restrictions [252](#)
- IMS procedure
 - description [639](#)
 - parameters
 - ALOT= [521](#)
 - AOI1= [521](#)
 - AOIS= [522](#)
 - APPC= [523](#)
 - APPCSE= [523](#)
 - APPLID1= [524](#)
 - APPLID2= [524](#)
 - ARMRST= [524](#)
 - ASOT= [525](#)
 - AUTO= [525](#)
 - BSIZ= [526](#)
 - CCTVCAN= [526](#)

IMS procedure (continued)
parameters (continued)

CIOP= [527](#)
CMDMCS= [528](#)
CPLOG= [529](#)
CRC= [530](#)
CSAPSB= [531](#)
DBBF= [531](#)
DBFP= [532](#)
DBFX= [533](#)
DBRCGRP= [534](#)
DBRCNM= [534](#)
DBWP= [534](#)
DC= [534](#)
DESC= [536](#)
DFSDF= [536](#)
DLINM= [537](#)
DLIPSB= [537](#)
DLQT= [537](#)
DMB= [538](#)
DMHVF= [538](#)
DPRTY= [538](#)
DSCT= [538](#)
DYNP= [538](#)
EMHB= [539](#)
EMHL= [539](#)
EPCB= [539](#)
ETO= [540](#)
EXVR= [540](#)
FBP= [540](#)
FDRMBR= [540](#)
FESTIM= [541](#)
FIX= [541](#)
FMTO= [541](#)
FP= [542](#)
FPOP= [542](#)
FPRLM= [543](#)
FPWP= [543](#)
FRE= [543](#)
GRNAME= [544](#)
GRSNAME= [544](#)
HIOP= [544](#)
HSBID= [544](#)
HSBMBR= [545](#)
IMSGROUP= [545](#)
IMSID= [545](#)
IOVFI= [546](#)
IRLM= [547](#)
IRLMNM= [547](#)
ISIS= [548](#)
LGMSGSZ= [550](#)
LGNR= [550](#)
LHTS= [550](#)
LOGT= [551](#)
LSO= [551](#)
LTERM= [552](#)
LUMC= [552](#)
LUMP= [552](#)
MCS= [554](#)
MNPS= [555](#)
MNPSPW= [555](#)
PRDR= [564](#)
PRLD= [565](#)
PSB= [565](#)

IMS procedure (continued)
parameters (continued)

PSBW= [565](#)
PST= [566](#)
PSWDC= [566](#)
QBUF= [567](#)
QBUFMAX= [567](#)
QBUFSZ= [568](#)
QTL= [568](#)
QTU= [569](#)
RCF= [569](#)
RCFTCB= [570](#)
RCLASS= [570](#)
RDMNM= [570](#)
READNUM= [571](#)
RECA= [571](#)
RECASZ= [571](#)
RES= [571](#)
RGN= [571](#)
RGSUF= [571](#)
RVFY= [572](#)
SAV= [572](#)
SGN= [573](#)
SGNGENRC= [574](#)
SHAREDQ= [574](#)
SHMSGSZ= [575](#)
SOD= [575](#)
SOUT= [575](#)
SPM= [576](#)
SRCH= [576](#)
SSM= [576](#)
SUF= [578](#)
SVC2= [578](#)
SYS= [579](#)
SYS1= [579](#)
SYS2= [580](#)
TCORACF= [580](#)
TRN= [581](#)
TSR= [581](#)
UHASH= [581](#)
UHTS= [581](#)
USERVAR= [582](#)
VAUT= [582](#)
VSPEC= [582](#)
WKAP= [583](#)
YEAR4= [583](#)
sample [639](#)
storing [517](#)
z/OS, and [210](#)
IMS PROCLIB data set
assigning procedure names [201](#)
controlling [201](#)
controlling modifications [201](#)
DFSPBxxx [201](#)
initializing [201](#)
tailoring [201](#)
IMS PROCLIB data set members
alphabetic listing [665](#)
DBFMSDBx [725](#)
DFS62DTx [727](#)
DFSDFRxx [828](#)
DFSFIXnn [830](#)
DFSINTxx [839](#)
DFSORSxx [847](#)

IMS PROCLIB data set members (*continued*)

- DFSPBDBC [848](#)
- DFSPBDCC [848](#)
- DFSPBIMS [848](#)
- DFSSQxxx [854](#)
- generated [198](#)
- Syntax Checker [388](#)
- tailoring [198](#)
- IMS Release and Control Region panel
 - panel field descriptions [384](#)
- IMS Release panel
 - panel field descriptions [384](#)
- IMS repository
 - data sets
 - states [165](#)
 - index and member data sets [164](#)
- IMS setup recommendations
 - FMTO option [339](#)
 - SYSDUMP DD [339](#)
- IMS Syntax Checker [201](#)
- IMS transactions
 - defining [113](#)
 - TRANSACT macro, using [113](#)
- IMS-to-IMS TCP/IP communications
 - examples
 - IMS Connect configuration statements [952](#)
- IMS.ACBLIB as a staging library [139](#)
- IMS.FORMAT as a staging library [139](#)
- IMS.JOBS data set [201](#)
- IMS.LGMSG data set [453](#)
- IMS.MODSTAT, used for active library status [139](#)
- IMS.PROCLIB
 - CSL manager [245](#)
 - DFSCGxxx member [245](#)
 - DFSDFxxx member [245](#)
 - DFSPBxxx IMS PROCLIB data set member [245](#)
 - DFSVSMxxx IMS PROCLIB data set member [245](#)
 - members that support a CSL [245](#)
- IMS.PROCLIB members
 - DFSDCxxx [736](#)
 - DFSHSBxx [834](#)
 - DFSPBxxx [847](#)
 - DFSSPMxx [849](#)
 - DFSVSMxx [857](#)
 - FRPCFG [911](#)
- IMS.QBLKS data set [453](#)
- IMS.SDFSRESL
 - concatenating for interactive dump [343](#)
- IMS.SHMSG data set [453](#)
- IMS= parameter [545](#)
- IMS= parameter for procedures [545](#)
- IMSBATCH procedure
 - parameters
 - ALTID= [521](#)
 - APARM= [522](#)
 - CKPTID= [527](#)
 - CPUTIME= [530](#)
 - DIRCA= [536](#)
 - IMSID= [545](#)
 - IMSPLEX= [546](#)
 - IN= [546](#)
 - LOCKMAX= [550](#)
 - MBR= [554](#)
 - NBA= [556](#)

IMSBATCH procedure (*continued*)

- parameters (*continued*)
 - OBA= [557](#)
 - OPT= [559](#)
 - PAGES= [562](#)
 - PARDLI= [562](#)
 - PREINIT= [564](#)
 - PRLD= [565](#)
 - PSB= [565](#)
 - RGN= [571](#)
 - SOUT= [575](#)
 - SPIE= [576](#)
 - SSM= [576](#)
 - STIMER=, message-driven programs [577](#)
 - SYS2= [580](#)
 - TEST= [580](#)
- IMSCOBGO procedure
 - description [650](#)
 - parameters
 - BKO= [525](#)
 - BUF= [526](#)
 - CKPTID= [527](#)
 - DBRC= [533](#)
 - EXCPVR= [540](#)
 - FMTO= [541](#)
 - IMSID= [545](#)
 - IMSPLEX= [546](#)
 - IOB= [546](#)
 - IRLM= [547](#)
 - IRLMNM= [547](#)
 - LOGA= [551](#)
 - LOGT= [551](#)
 - MBR= [554](#)
 - MON= [555](#)
 - PRLD= [565](#)
 - PSB= [565](#)
 - RGN= [571](#)
 - RST= [572](#)
 - SOUT= [575](#)
 - SPIE= [576](#)
 - SRCH= [576](#)
 - SWAP= [579](#)
 - SYS2= [580](#)
 - TEST= [580](#)
- IMSCOBOL procedure
 - parameters
 - MBR= [554](#)
 - SOUT= [575](#)
 - SYS2= [580](#)
- IMSCTF macro
 - description [103](#)
 - setting checkpoints [103](#)
- IMSCTRL macro
 - defining BMP regions [103](#)
 - defining message regions [103](#)
 - defining regions
 - BMP [103](#)
 - message [103](#)
 - description [103](#), [427](#)
 - parameters
 - CMDCHAR= [427](#)
 - DBRC= [187](#), [427](#)
 - DBRCNM= [427](#)
 - DCLWA= [427](#)

IMSCTRL macro *(continued)*

parameters *(continued)*

DESC= [427](#)
DLINM= [427](#)
ETOFEAT= [427](#)
HSB= [427](#)
IMSID= [427](#)
IRLM= [427](#)
IRLMNM= [427](#)
MAXCLAS= [427](#)
MAXIO= [427](#)
MAXREGN= [427](#)
MCS= [427](#)
MODBLKS= [427](#)
MSVERIFY [427](#)
MSVID= [427](#)
NAMECHK= [427](#)
NUCLEUS [427](#)
ON-LINE [427](#)
SYSTEM= [427](#)

selecting a lock manager [104](#)

syntax diagram [427](#)

use without specifying MODBLKS [427](#)

IMSDALOC procedure, process [654](#)

IMSFP procedure

description [656](#)

parameters

ALOT= [521](#)
ALTID= [521](#)
APARM= [522](#)
CPUTIME= [530](#)
DBLDL= [533](#)
DIRCA= [536](#)
IMSID= [545](#)
LOCKMAX= [550](#)
MBR= [554](#)
NBA= [556](#)
OPT= [559](#)
PREINIT= [564](#)
PRLD= [565](#)
PSB= [565](#)
RGN= [571](#)
SOD= [575](#)
SOUT= [575](#)
SSM= [576](#)
STIMER=, message-driven programs [577](#)
SYS2= [580](#)
TLIM= [580](#)

IMSGEN macro

assembler and binder options [441](#)

communication options parameters

MFSTEST= [437](#)
SYSMSG= [437](#)

data set option parameters

MACLIB= [437](#)
MACSYS= [437](#)
MODGEN= [437](#)
NODE= [437](#)
OBJDSET= [437](#)
PROCLIB= [437](#)
SCEERUN= [437](#)
UMAC0= [437](#)
UMACx= [437](#)
USERLIB= [437](#)

IMSGEN macro *(continued)*

general communication options [437](#)

IMS data set options [437](#)

JCL statement parameters

JCL= [437](#)
JOBCTL= [437](#)
MFSDfmt= [437](#)
ONEJOB= [437](#)
PRTY= [437](#)
SCL= [437](#)
UJCLx= [437](#)

JCL statements [437](#)

MFS [173](#)

parameters

ASM= [437](#)
ASMPRT= [437](#)
LKPRT= [437](#)
LKRGN= [437](#)
LKSIZE= [437](#)
SUFFIX= [437](#)
TERM= [437](#)
UPDTPRT= [437](#)

sample IMSGEN macro statement [437](#)

security options [437](#)

security options parameters

SECCNT= [437](#)

syntax diagram [437](#)

IMSGROUP= parameter [545](#)

IMSGROUP= parameter for procedures [545](#)

IMSID [131](#)

IMSID= parameter [427](#), [545](#)

IMSID= parameter for procedures [545](#)

IMSMSG job [657](#)

IMSplex

FDBR

requirements [136](#)

keyword parameters [917](#)

managing serialized programs [704](#)

MEMBER parameter [917](#)

shared queues

managing serialized programs [704](#)

TMEMBER parameter [917](#)

IMSPLEX

parameters [928](#)

statement [928](#)

syntax [928](#)

IMSPLEX macro

data set option parameters [437](#)

IMSPLEX= parameter [546](#), [728](#), [911](#)

IMSPLEX= parameter for procedures [546](#)

IMSPLI procedure

DD statements [657](#)

parameters

MBR= [554](#)
SPIE= [576](#)
SYS2= [580](#)

IMSPLIGO procedure

DD statements [659](#)

description [659](#)

parameters

BKO= [525](#)
BUF= [526](#)
CKPTID= [527](#)
DBRC= [533](#)

IMSPLIGO procedure (*continued*)

parameters (*continued*)

EXCPVR= [540](#)
FMTO= [541](#)
IMSID= [545](#)
IMSPLEX= [546](#)
IOB= [546](#)
IRLM= [547](#)
IRLMNM= [547](#)
LOGA= [551](#)
LOGT= [551](#)
MBR= [554](#)
MON= [555](#)
PRLD= [565](#)
PSB= [565](#)
RGN= [571](#)
RST= [572](#)
SOUT= [575](#)
SPIE= [576](#)
SRCH= [576](#)
SWAP= [579](#)
SYS2= [580](#)
TEST= [580](#)

IMSRRDR procedure

DD statement [661](#)

description [661](#)

parameters

CLASS= [527](#)
MBR= [554](#)
SYS2= [580](#)

storing [517](#)

z/OS, and [210](#)

IMSRSC repository

backing out

runtime descriptor definitions created with IMPORT
command [90](#), [91](#)

runtime resource definitions created with IMPORT
command [90](#), [91](#)

change lists [43](#)

creating

runtime resource definitions [53](#)

creating MSC resource definitions [60](#)

creating resource and descriptor definitions [58](#)

deleting

runtime descriptor definitions [69](#)

runtime resource definitions [69](#)

deleting resource and descriptor definitions from [76](#)

DFSDfxxx [805](#)

exporting

descriptor definitions [79](#)

MODBLKS descriptor definitions [81](#)

MODBLKS resource definitions [81](#)

MSC descriptor definitions [83](#)

MSC resource definitions [83](#)

resource definitions [79](#)

falling back from using [95](#)

falling back from using for MODBLKS resources [95](#)

falling back from using for MSC resources [97](#), [98](#)

importing

descriptor definitions [84](#), [89](#)

resource definitions [84](#), [89](#)

in FDBR region [37](#)

overview [37](#), [40](#)

resource lists [42](#)

IMSRSC repository (*continued*)

Resource Manager (RM)

initialization parameters [719](#)

system definition checklist [40](#)

updating

resource descriptor definitions [61](#)

runtime resource definitions [61](#)

updating MODBLKS resource and descriptor definitions
for a single IMS or for multiple IMSs with unique
definitions [67](#)

for multiple IMS systems with the same set of
definitions [68](#)

updating MSC resource definitions [69](#)

updating resource and descriptor definitions [67](#)

IMSRSC repository data sets

allocating [163](#)

IMSWT= parameter [736](#)

IN= parameter [546](#)

IN= parameter for procedures [546](#)

incore trace tables

formatting [306](#)

index data sets

IMS repository [164](#)

Indirect List Data Set (ILDS)

HALDB

partitions [171](#)

pointers

direct [171](#)

indirect [171](#)

Indirect List Entry (ILE) [171](#)

INDOUBT EEQEs

/DBRECOVERY command, preventing for [888](#)

INIT OLREORG

ALTER option

IMS catalog considerations [281](#)

initializing data sets [170](#)

initializing IMS system data sets [139](#)

INQ= parameter [498](#)

INQUIRY= parameter [469](#), [498](#)

installation

multiple copies of IMS

different release levels [132](#)

same release level and type [131](#)

steps for a full installation [1](#)

integrity

lock manager [104](#)

Interactive Dump Formatter

making IMS.SDFSRESL available [343](#)

interactive problem control system [972](#)

Interactive Problem Control System (IPCS)

sample control statements [973](#)

starting with IMS Dump Formatter [973](#)

interface parameter trace table (INTP) [665](#)

interface trace table (INTF)

CQS trace table type [665](#)

SCI trace table type [665](#)

Intersystem Communication (ISC)

IMS Connect

parameters [929](#)

statement [929](#)

syntax [929](#)

INTF (interface trace table)

CQS trace table type [665](#)

SCI trace table type [665](#)

INTP (interface parameter trace table) [665](#)

invoking

IMS Connect [297](#)

IOB= parameter [546](#)

IOB= parameter for procedures [546](#)

IOVF control intervals [546](#)

IOVFI= parameter [546](#)

IOVFI= parameter for procedures [546](#)

IPCS (Interactive Problem Control System)

sample control statements [973](#)

starting with IMS Dump Formatter [973](#)

IQMRHO [153](#)

IRLM

coupling facility structure names [882](#)

DEADLOK parameter [535](#)

entries for z/OS PPT [25](#)

execution parameters [177](#)

how it uses SDUMP [973](#)

IMSCTRL macro

IRLM parameter [427](#)

IRLMNM parameter [427](#)

LOCKTIME parameter [885](#)

performance and DEADLOK parameter [535](#)

selecting a lock manager [104](#)

startup procedure [633](#)

IRLM= parameter [427](#), [547](#)

IRLM= parameter for procedures [547](#)

IRLMGRP= parameter [547](#)

IRLMGRP= parameter for procedures [547](#)

IRLMID= parameter [547](#)

IRLMID= parameter for procedures [547](#)

IRLMNM= parameter [427](#), [547](#)

IRLMNM= parameter for procedures [547](#)

ISC (Intersystem Communication)

IMS Connect

parameters [929](#)

statement [929](#)

syntax [929](#)

ISC configuration statement [929](#)

ISC surveillance link [471](#), [489](#)

ISIS= parameter [548](#)

ISIS= parameter for procedures [548](#)

ISPF

Syntax Checker panels [382](#)

ISSUE681= parameter [876](#)

ISSUE840= parameter [877](#)

J

Java batch processing (JBP) regions

Db2 for z/OS access

configuring [333](#)

Java message processing (JMP) regions

Db2 for z/OS access

configuring [333](#)

JBP (Java batch processing) regions

Db2 for z/OS access

configuring [333](#)

JCL

to print RECORDER output [308](#)

JCL values

BPECFG [297](#)

HWSCFG [297](#)

RGN [297](#)

JCL values (*continued*)

SOUT [297](#)

JCL= parameter [437](#)

JCLIN process of system definition [25](#)

JDBC drivers

Db2 for z/OS JDBC/SQLJ 1.2 driver [334](#)

Db2 for z/OS JDBC/SQLJ 2.0 driver [333](#)

Db2 for z/OS Universal JDBC driver

[333](#)

JMP (Java message processing) regions

Db2 for z/OS access

configuring [333](#)

job accounting [437](#)

JOBCTL= parameter [437](#)

JVM options [840](#), [841](#), [844](#)

JVM usage statistics [222](#)

JVM usage statistics records [223](#)

JVM= parameter for procedures [548](#)

JVMOPMAS=

parameter description [549](#)

JVMOPMAS= parameter for procedures [549](#)

JVMOPWKR=

parameter description [550](#)

JVMOPWKR= parameter [550](#)

JVMOPWKR= parameter for procedures [550](#)

JVMOPMAS= parameter [549](#)

K

KeepAlive function of TCP/IP [917](#)

keyboard shortcuts [xv](#)

KEYEVENT= parameter [836](#)

Keyword Display panel

action pull-down options [389](#)

display options [385](#)

inserting keywords [390](#)

interrupting processing [390](#)

panel field descriptions [385](#), [386](#)

saving processed members [391](#)

keywords

MAXREGN [166](#)

L

LANG parameter

member of the IMS PROCLIB data set [665](#)

LANG= parameter [405](#)

language interface module [329](#)

large sequential data sets

defining [171](#)

fallback from [173](#)

LATC (latch trace table) [665](#)

LATC= parameter [877](#)

latch trace table (LATC) [665](#)

legal notices

notices [977](#)

trademarks [977](#), [978](#)

LGEN subparameter [17](#)

LGMSGSZ= parameter [550](#)

LGMSGSZ= parameter for procedures [550](#)

LGNR= parameter [550](#)

LGNR= parameter for procedures [550](#)

LHTS= parameter [550](#)

- LHTS= parameter for procedures [550](#)
- LIBATCH procedure
 - parameters
 - PSB= [565](#)
- libraries
 - active [139](#)
 - inactive [139](#)
 - maintenance [139](#)
 - staging [139](#)
- limit count scheduling [119](#)
- limit priority scheduling [119](#)
- LINE macro
 - parameters
 - ADDR= [448](#)
 - BACKUP= [448](#)
 - BUFSIZE= [448](#)
 - syntax diagram [448](#)
 - SYSIN Local Card Reader [448](#)
- LINEGRP macro
 - description [450](#)
 - parameters
 - BACKUP= [450](#)
 - DDNAME= [450](#)
 - EDIT= [450](#)
 - FEAT= [450](#)
 - UNITYPE= [450](#)
 - syntax [450](#)
- LINEGRP macro statement [166](#)
- LINKLIST [333](#)
- LIT (Language Interface Token) [329](#)
- LIT= parameter [329](#)
- LKASID [860](#)
- LKPRT= parameter [437](#)
- LKRGN= parameter [437](#)
- LKSIZE= parameter [437](#)
- LNK= parameter [836](#)
- load repository server from log records
 - sample startup procedure [599](#)
- local option client communications
 - configuring security [300](#)
- local SYSOUT line groups
 - macro statements [359](#)
- lock manager
 - selecting [104](#)
- lock timeout function, IRLM [885](#)
- LOCK= parameter [877](#)
- LOCKMAX= parameter [550](#)
- LOCKMAX= parameter for procedures [550](#)
- LOCKSEC= parameter [736](#)
- LOCKTAB= parameter [551](#)
- LOCKTAB= parameter for procedures [551](#)
- Log Archive utility [152](#)
- log data sets
 - WADS [150](#)
- LOG= parameter [836](#), [880](#)
- LOGA= parameter [551](#)
- LOGA= parameter for procedures [551](#)
- Logger
 - DFSDFxxx [794](#)
- logging
 - integrity [153](#)
- logical record length [693](#)
- logical term name [465](#)
- logon descriptors

- logon descriptors (*continued*)
 - format [815](#), [827](#)
 - parameters [815](#), [827](#)
 - syntax [815](#), [827](#)
- LOGR policy
 - CQS
 - MAXBUFSIZE specification [242](#)
 - MAXBUFSIZE specification for CQS [242](#)
- LOGT= parameter [551](#)
- LOGT= parameter for procedures [551](#)
- long busy handling function
 - enabling [884](#)
- LRECL [693](#)
- LSO (local storage option)
 - DL/I address space, specifying [105](#)
 - PSB pools, defining [105](#)
 - storage considerations [105](#)
- LSO= parameter [551](#)
- LSO= parameter for procedures [551](#)
- LTE= parameter [551](#)
- LTE= parameter for procedures [551](#)
- LTERM
 - specifying [465](#)
- LTERM= parameter [471](#), [552](#)
- LTERM= parameter for procedures [552](#)
- LU 6 terminal
 - TERMINAL macro statement, specifying [471](#)
 - VTAM devices [470](#)
- LUMC= parameter [552](#)
- LUMC= parameter for procedures [552](#)
- LUMI= parameter [877](#)
- LUMP= parameter [552](#)
- LUMP= parameter for procedures [552](#)
- LUNAME= parameter [728](#)

M

- MACLIB= parameter [437](#)
- macro keywords
 - EDIT on TRANSACT macro [115](#)
 - INQUIRY on TRANSACT macro [115](#)
 - MSGTYPE on TRANSACT macro [115](#)
 - PROCLIM on TRANSACT macro [115](#)
 - PRTY on TRANSACT macro [119](#)
- macro statements
 - alphabetic listing [395](#)
 - APPLCTN
 - online programs, declaring [109](#)
 - application program [356](#)
 - BUFPOOLS
 - MFS pool size, controlling [107](#)
 - checking [21](#)
 - coding conventions [395](#)
 - COMM [361](#)
 - data communication [359](#)
 - database [356](#)
 - DATABASE
 - data sharing [112](#)
 - online databases, declaring [109](#)
 - finance communication systems [364](#)
 - FPCTRL [427](#)
 - IMSCTRL
 - checkpoint frequency, setting [103](#)
 - data sharing [112](#)

- macro statements (*continued*)
 - IMSCTRL (*continued*)
 - description [427](#)
 - LINEGRP [450](#)
 - local SYSOUT line groups [359](#)
 - maximum occurrences [395](#)
 - MSGQUEUE [453](#)
 - MSLINK [457](#)
 - MSNAME [460](#)
 - MSPLINK [461](#)
 - NAME [465](#)
 - NTO devices [367](#)
 - resource naming rules [395](#)
 - RTCODE [469](#)
 - SUBPOOL [470](#)
 - system configuration [371](#)
 - system configuration macros
 - BUFPOOLS [103](#)
 - IMSCTF [103](#)
 - IMSCTRL [103](#)
 - system configuration macros, use of [103](#)
 - TERMINAL
 - 2740 terminal [471](#)
 - 2741 terminal [471](#)
 - 2780 terminal [471](#)
 - 3270 terminal [471](#)
 - 3600 work station [471](#)
 - Finance work station [471](#)
 - LU 6 [471](#)
 - SLU 1 [471](#)
 - SLU 2 [471](#)
 - SLU P [471](#)
 - SPOOL [471](#)
 - System/3 terminal [471](#)
 - System/7 terminal [471](#)
 - TRANSACT
 - description [498](#)
 - IMS transactions, defining [113](#)
 - TYPE [514](#)
 - VTAM [360](#), [361](#), [363](#), [366–369](#)
 - VTAMPOOL [516](#)
- macros
 - DFSMDA [152](#)
 - TERMINAL [166](#)
 - type of system definition required for change [5](#)
- MACSYS= parameter [437](#)
- MACSYS= parameter for procedures [553](#)
- maintenance
 - SMP/E [25](#)
 - with online change [139](#)
- master terminal
 - configuring [128](#)
 - devices, choosing [128](#)
 - secondary logging [128](#)
 - secondary, commands that can be copied to [409](#)
 - specifying [128](#), [465](#)
- master trace table Size, z/OS [339](#)
- max communication retry parameter [911](#)
- MAXBUFSIZE parameter
 - CQS recommendation [242](#)
 - LOGR policy for CQS [242](#)
- MAXCLAS= parameter [427](#)
- MAXCSA= parameter [553](#)
- MAXCSA= parameter for procedures [553](#)
- MAXFILEPROC parameter, UNIX System Services [917](#)
- MAXIO= parameter [427](#)
- MAXPST= parameter [553](#)
- MAXPST= parameter for procedures [553](#)
- MAXREGN keyword [166](#)
- MAXREGN= parameter [427](#)
- MAXRGN= parameter [498](#)
- MAXSB= parameter [871](#)
- MAXTHRD= parameter [968](#)
- MAXTHRD= parameter for procedures [553](#)
- MAXUSRS= parameter [554](#)
- MAXUSRS= parameter for procedures [554](#)
- MBR_CORE_MAX= parameter [911](#)
- MBR= parameter [554](#)
- MBR= parameter for procedures [554](#)
- MCS= parameter [427](#), [554](#)
- MCS= parameter for procedures [554](#)
- member data sets
 - IMS repository [164](#)
- members of the IMS PROCLIB data set
 - Base Primitive Environment (BPE)
 - trace table types [665](#)
 - LANG parameter [665](#)
 - sharing configurations [665](#)
 - TRCLEV [665](#)
- message
 - batching [119](#)
 - CQS0268W [703](#)
 - migrating [153](#)
 - queue
 - data set [153](#)
 - testing users [153](#)
 - scheduling [116](#)
- message classes
 - assigning [118](#)
 - priorities [118](#)
- message format pool
 - size, estimating [107](#)
 - size, specifying [180](#)
- Message Format Service (MFS)
 - pool space
 - BUFPOOLS macro [107](#)
- message prefix
 - sizes
 - Version 10 [453](#)
 - Version 8 [453](#)
 - Version 9 [453](#)
- Message Processing Region
 - data communication EXEC parameters [189](#), [192](#)
 - parameters, categories and purposes [189](#)
 - performance-related parameters [189](#)
 - PSB-related EXEC parameters [189](#), [192](#)
 - recovery-related parameters [187](#), [189](#), [192](#)
 - region-control EXEC parameters [189](#), [192](#)
 - security-related EXEC parameters [189](#), [192](#)
- message queue
 - data set allocation [453](#)
 - data sets
 - IMS.LGMSG [453](#)
 - IMS.QBLKS [453](#)
 - IMS.SHMSG [453](#)
- message queue data sets
 - restrictions in XRF [153](#)
- message regions

message regions (*continued*)
 choosing number [103](#)

messages
 processing limits [120](#)

MFS
 buffer pool use [108](#)
 BUFPOOLS macro [173](#)
 COMM macro [173](#)
 concatenating format libraries [175](#)
 device descriptor format [821](#)
 device descriptors [216](#)
 displaying buffer pool counters [175](#)
 FREs [108](#)
 IMSGEN macro [173](#)
 INDEX directory [175](#)
 MSGQUEUE macro [173](#)
 pool space, allocating [107](#)
 pool space, defining [107](#)
 system definition and programming considerations [173](#)
 TERMINAL [173](#)
 TYPE macro [173](#)

MFS device descriptors
 format [815](#), [827](#)
 parameters [815](#), [827](#)
 syntax [815](#), [827](#)

MFSDFMT= parameter [437](#)

MFSEXIT= parameter [410](#)

MFSEXITF= parameter for procedures [554](#), [575](#)

MFSEXITS= parameter for procedures [554](#)

MFSPPEDEF= parameter [736](#)

MFSTEST (Message Format Service test facility) [411](#), [447](#)

MFSTEST= parameter [437](#)

migrating
 ACB management [254](#), [256](#)
 enabling IMS-managed ACBs in systems that do not use an IMS catalog [256](#)
 enabling IMS-managed ACBs with an existing IMS catalog [254](#)

MINTHRD= parameter [968](#)

MINTHRD= parameter for procedures [555](#)

MNPS= parameter [555](#), [838](#)

MNPS= parameter for procedures [555](#)

MNPSPW= parameter [555](#), [838](#)

MNPSPW= parameter for procedures [555](#)

MOD= parameter [555](#)

MOD= parameter for procedures [555](#)

MODBLKS
 in a DRD environment [44](#)
 use IMSCTRL without specifying [427](#), [436](#)

MODBLKS descriptor definitions
 exporting to IMSRSC repository [81](#)
 exporting to RDDS [80](#)

MODBLKS resource definitions
 exporting to IMSRSC repository [81](#)
 exporting to RDDS [80](#)
 importing with DRD [85](#)

MODBLKS resources
 dynamic definition
 enabling [49](#)
 preparing to enable [49](#)

MODBLKS type system definition [2](#)

MODBLKS= parameter [427](#)

MODE= parameter [498](#), [728](#)

MODEL= parameter [471](#)

MODETBL= parameter
 description [461](#)
 displaying [461](#)
 displaying name [457](#)

MODGEN= parameter [437](#)

module preload
 description [845](#)

modules
 DFSVC000 [131](#)
 DFSVNUCx [131](#)
 suffix rules [131](#)

MON= parameter [555](#)

MON= parameter for procedures [555](#)

monitoring
 message queue users [153](#)

MRQPSBN= parameter [453](#)

MSC
 descriptors [217](#)
 example [371](#)
 IMS Connect
 defining a TCP/IP connection [311](#), [312](#), [318](#)
 defining a TCP/IP connection, example [316](#)
 macro statements, preparing [130](#)

macros
 MSLINK [130](#)
 MSNAME [130](#)
 MSPLINK [130](#)
 NAME [130](#)
 parameters [932](#)
 statement [932](#)
 syntax [932](#)
 system definition
 generic resources, enabling for MSC TCP/IP [318](#)
 TCP/IP connections [311](#), [312](#)
 TCP/IP connections, examples [316](#)

TCP/IP connections
 generic resources, enabling [318](#)
 TCP/IP connections, defining
 examples [316](#)

MSC (multiple systems coupling)
 network [131](#)

MSC (Multiple Systems Coupling)
 configuring
 DFSDFxxx member [797](#)
 defining
 DFSDFxxx member [797](#)
 descriptor [822](#)
 DFSDFxxx
 MSC section [797](#)
 dynamic definition
 enabling [52](#)
 specifying different buffer size [461](#)

MSC descriptor definitions
 exporting to IMSRSC repository [83](#)

MSC descriptors
 format [815](#), [827](#)
 parameters [815](#), [827](#)
 syntax [815](#), [827](#)

MSC resource definitions
 exporting to IMSRSC repository [83](#)
 importing with DRD [87](#)

MSC= parameter for procedures [556](#)

MSCSEC= parameter [736](#)

MSCT= parameter [877](#)

MSCVGR= parameter [736](#)
MSDB
 DBFMSDBx member [725](#)
 deleting dynamically [71](#)
MSDB (main storage database)
 dynamic resource definition [54](#)
 loading [182](#)
MSDB= parameter [556](#)
MSDB= parameter for procedures [556](#)
MSDBABND= parameter [726](#)
MSG= parameter [556](#)
MSG= parameter for procedures [556](#)
MSGDEL= parameter [470](#), [471](#)
MSGQ= parameter [856](#)
MSGQUEUE macro
 description [453](#)
 MFS [173](#)
 parameters
 BUFFERS= [453](#)
 DSET= [453](#)
 MRQPSBN= [453](#)
 RECLNG= [453](#)
 SHUTDWN= [453](#)
 syntax diagram [453](#)
MSGTYPE= parameter [498](#)
MSLINK macro
 description [457](#)
 parameters
 BACKUP= [457](#)
 MODETBL= [457](#)
 MSPLINK= [457](#)
 OPTIONS= [457](#)
 PARTNER= [457](#)
 syntax diagram [457](#)
MSNAME macro
 description [460](#)
 label field [460](#)
 parameters
 SYSID= [460](#)
 syntax diagram [460](#)
MSPLINK macro
 description [461](#)
 parameters
 ADDR= [461](#)
 BACKUP= [461](#)
 BUFSIZE= [461](#)
 DDNAME= [461](#)
 MODETBL= [461](#)
 NAME= [461](#)
 OPTIONS= [461](#)
 SESSION= [461](#)
 TYPE= [461](#)
 syntax diagram [461](#)
MSPLINK= parameter
 assigning logical links [457](#)
MSVERIFY type system definition [2](#)
MSVERIFY= parameter [427](#)
MSVID= parameter [427](#)
MTOUSID= parameter [736](#)
multi-area structures
 defining DEDB buffer pools [861](#)
multiple copies of IMS
 running on one operating system [132](#)
multiple IMS systems, module suffix rules [131](#)

multiple message queues
 long [153](#)
 short [153](#)
Multiple Systems Coupling (MSC)
 configuring
 DFSDfxxx member [797](#)
 defining
 DFSDfxxx member [797](#)
 descriptor [822](#)
 DFSDfxxx
 MSC section [797](#)
 dynamic definition
 enabling [52](#)
 specifying different buffer size [461](#)

N

NAME macro
 description [465](#)
 parameters
 COMPT= [465](#)
 EDIT= [465](#)
 ICOMPT= [465](#)
 lterm [465](#)
 OUTPUT= [465](#)
 remote Item name [465](#)
 syntax diagram [465](#)
NAME= parameter
 changing VTAM node name [461](#)
 description [461](#)
NAMECHK= parameter [427](#)
NBA= parameter [556](#)
NBA= parameter for procedures [556](#)
NBRSEGS= parameter [726](#)
NHTS= parameter [557](#)
NHTS= parameter for procedures [557](#)
NLXB= parameter [557](#)
NLXB= parameter for procedures [557](#)
NODE= keyword [131](#)
NODE= parameter [437](#)
NODE1= parameter for procedures [557](#)
NODE2= parameter for procedures [557](#)
NOIC= parameter [965](#)
NOLKASID [860](#)
nonswitched communication lines
 described by LINE macro [448](#)
NOPROCH= parameter [965](#)
normal priority for scheduling [119](#)
NTO device
 macro statements [367](#)
 TERMINAL macro statement [471](#)
NUC= parameter [834](#)
nucleus
 when generated [5](#)
nucleus definition [436](#)
NUCLEUS type system definition [2](#)
NUCLEUS= parameter [427](#)

O

OBA= parameter [557](#)
OBA= parameter for procedures [557](#)
OBJDSET= parameter [437](#)

OCMD= parameter [877](#)
 ODACCESS
 parameters [934](#)
 statement [934](#)
 syntax [934](#)
 ODBA (Open Database Access)
 defining PSB names [112](#)
 ODBASE= parameter [557](#)
 ODBASE= parameter for procedures [557](#)
 ODBM
 user exit list member of the IMS PROCLIB data set [684](#)
 ODBM (Open Database Manager)
 configuration member of the IMS PROCLIB data set [245](#)
 configuring, CSLDCxxx member of the IMS PROCLIB data set [706](#)
 CSLDCxxx member of the IMS PROCLIB data set [706](#)
 execution parameters [595](#)
 initialization member of the IMS PROCLIB data set [245](#)
 initialization parameters member of the IMS PROCLIB data set [711](#)
 PROCLIB members
 CSLDCxxx [706](#)
 sample startup procedure [595](#)
 user exit list member of the IMS PROCLIB data set [712](#)
 ODBM user exit list member of the IMS PROCLIB data set [684](#)
 ODBMCFG= parameter [558](#)
 ODBMCFG= parameter for procedures [558](#)
 ODBMINIT= parameter [558](#)
 ODBMINIT= parameter for procedures [558](#)
 ODBMNAME= parameter [558](#)
 ODBMNAME= parameter for procedures [558](#)
 offloading trace data set [344](#)
 OLC= parameter [728](#)
 OLCSTAT= parameter [728](#)
 OLDS (online log data set)
 allocating [147](#)
 block sizes [148](#)
 ddnames requirements [148](#)
 dynamic allocation [148](#)
 formatting [150](#)
 OLDSDEF control statement [148](#)
 OLDSDEF control statement [148](#)
 OM exit routine member of the IMS PROCLIB data set
 EXITMBR parameter [665](#)
 OM trace table types
 * (asterisk) [665](#)
 CSL [665](#)
 ERR [665](#)
 OM [665](#)
 PLEX [665](#)
 recommendations [665](#)
 OMINIT= parameter for procedures [558](#)
 OMNAME= parameter for procedures [558](#)
 OMPROC= parameter [728](#)
 ON-LINE type system definition [2](#)
 ON-LINE= parameter [427](#)
 ONEJOB= parameter [437](#)
 online change
 ACBLIB members
 defining with DFSMDA member [145](#)
 defining with IMS procedure [145](#)
 system data sets [139](#)
 Online Change data sets [139](#)
 online databases, declaring [109](#)
 online ddnames [143](#)
 online DEDB utility region parameters [187](#)
 online programs
 characteristics [109](#)
 declaring [109](#)
 Online regions
 IMS management of ACBs [261](#)
 online system data sets
 dependencies [143](#)
 list of [143](#)
 online systems
 configuring alternative IMS online systems [22](#)
 SUFFIX= keyword to specify alternate configurations [22](#)
 Open Database Access (ODBA)
 defining PSB names [112](#)
 Open Database Manager
 CSLDCxxx syntax [707](#)
 Open Database Manager (ODBM)
 configuration member of the IMS PROCLIB data set [245](#)
 configuring, CSLDCxxx member of the IMS PROCLIB data set [706](#)
 CSLDCxxx member of the IMS PROCLIB data set [706](#)
 execution parameters [595](#)
 initialization member of the IMS PROCLIB data set [245](#)
 initialization parameters member of the IMS PROCLIB data set [711](#)
 PROCLIB members
 CSLDCxxx [706](#)
 sample startup procedure [595](#)
 user exit list member of the IMS PROCLIB data set [712](#)
 Open Transaction Manager Access (OTMA)
 client attributes, global [902](#)
 client descriptor [888](#)
 clients
 defaults [902](#)
 default client parameters [902](#)
 descriptors
 client descriptor [888](#)
 DFSOTMA descriptor [902](#)
 message flood protection
 client descriptor [888](#)
 wait-syncpoint timeout values
 client descriptor [888](#)
 Operations Manager
 set up tracing [345](#)
 Operations Manager (OM)
 execution parameters [597](#)
 initialization parameters member of the IMS PROCLIB data set [714](#)
 Resource Manager (RM)
 sample user exit list member of the IMS PROCLIB data set [245](#)
 sample startup procedure [597](#)
 user exit list member of the IMS PROCLIB data set [245](#), [715](#), [716](#)
 OPT= parameter [559](#)
 OPT= parameter for procedures [559](#)
 options
 AUTOSCH [166](#)
 OPTIONS statement [330](#)
 OPTIONS= parameter
 changing ASR option [457](#)
 description [457](#), [461](#)

OPTIONS= parameter (*continued*)
 displaying [461](#)
 displaying ASR option [457](#)
 overriding [459](#)
 ORS= parameter [559](#)
 ORS= parameter for procedures [559](#)
 ORSMBR= parameter [559](#)
 ORSMBR= parameter for procedures [559](#)
 ORTT= parameter [877](#)
 OSAM
 buffer pools, defining
 dynamically [208](#), [209](#)
 buffers
 adjusting [206](#)
 adjusting dynamically [206](#)
 coupling facility [882](#), [883](#)
 dynamic database buffer pools
 DFSDFxxx [801](#)
 I/O errors, tracing [876](#)
 sequential buffering [210](#)
 subpools
 defining [209](#)
 subpools, defining [868](#)
 OSAM (overflow sequential access method)
 allocating data sets [155](#)
 reallocating data sets [155](#)
 sample OSAM data set allocation JCL [155](#)
 OTHR= parameter [559](#)
 OTHR= parameter for procedures [559](#)
 OTMA
 client descriptors [888](#)
 connections between IMS systems, defining
 super member support [324](#)
 control flow, tracing [878](#)
 DCC procedure [611](#)
 destination descriptor [895](#)
 destination descriptors [888](#)
 DFSYDTx PROCLIB member [888](#)
 generic resource (GRNAME) parameter [544](#)
 IMS Connect
 defining a TCP/IP connection, example [324](#)
 IMS-to-IMS TCP/IP
 communications
 super member support [324](#)
 message prefix sizes [453](#)
 PROCLIB member DFSYDTx [888](#)
 system definition
 IMS-to-IMS TCP/IP connections [322](#)
 IMS-to-IMS TCP/IP connections, super member
 support [324](#)
 TCP/IP connections, examples [324](#)
 TCP/IP connections, defining
 examples [324](#)
 OTMA (Open Transaction Manager Access)
 client attributes, global [902](#)
 client descriptor [888](#)
 clients
 defaults [902](#)
 default client parameters [902](#)
 descriptors
 client descriptor [888](#)
 DFSOTMA descriptor [902](#)
 DFSOTMA descriptor [902](#)
 message flood protection

OTMA (Open Transaction Manager Access) (*continued*)
 message flood protection (*continued*)
 client descriptor [888](#)
 wait-syncpoint timeout values
 client descriptor [888](#)
 OTMA destination descriptor [895](#)
 OTMA= parameter [559](#)
 OTMA= parameter for procedures [559](#)
 OTMAASY= parameter for procedures [560](#)
 OTMAMD= parameter for procedures [561](#)
 OTMANM= parameter [561](#)
 OTMANM= parameter for procedures [561](#)
 OTMASE= parameter [561](#)
 OTMASE= parameter for procedures [561](#)
 OTMASP= parameter [562](#)
 OTMASP= parameter for procedures [562](#)
 OTMT= parameter [878](#)
 OUT= parameter [562](#)
 OUT= parameter for procedures [562](#)
 OUTBND= parameter [728](#), [736](#)
 OUTBUF= parameter [471](#), [820](#)
 output data sets, creating [345](#)
 OUTPUT= parameter [465](#)
 overflow sequential access method. [155](#)
 OVLA= parameter [562](#)
 OVLA= parameter for procedures [562](#)

P

PAGES= parameter [562](#)
 PAGES= parameter for procedures [562](#)
 parallel database open, disabling [881](#)
 parallel session support [516](#)
 parameter
 performance-related [180](#)
 Parameter Syntax Checker panel
 panel field descriptions [393](#)
 parameters
 ABND= [521](#)
 ACBIN64= [210](#)
 ACCESS= [416](#)
 ACTIV= [957](#)
 ADDR= [448](#), [461](#)
 AGN= [521](#)
 AL= [966](#)
 ALARM= [836](#)
 ALOT= [818](#)
 ALTRESL [973](#)
 AOEXIT= [408](#)
 AOI= [498](#)
 AOS= [736](#)
 APPCASY= [736](#)
 APPCIOT= [736](#)
 APPCMAXC= [736](#)
 APPCRCV= [736](#)
 APPLFE= [523](#)
 APPLID= [408](#)
 ARC= [187](#)
 ASM= [437](#)
 ASMPRT= [437](#)
 ASOT= [819](#), [823](#)
 ASSNCHANGE= [736](#)
 AUDIT_DEFAULT= [911](#)
 AUDIT_FAIL= [911](#)

parameters (continued)

AUDIT_ID= [911](#)
 AUDIT_LEVEL= [911](#)
 AUDIT_LOG= [911](#)
 AUDIT= [911](#)
 AUTHLOG= [736](#)
 AUTLCHANGE= [736](#)
 AUTLDESC= [824](#)
 AUTLGN= [824](#)
 AUTLID= [824](#)
 AUTLMOD= [824](#)
 AUTO= [836](#)
 BACKUP= [448](#), [450](#), [457](#), [461](#), [471](#), [514](#), [819](#)
 BHBUF= [957](#)
 BMPUSID= [736](#)
 BPECFG= [525](#)
 BSIZ= [526](#)
 BUF= [526](#)
 BUFFERS= [453](#)
 BUFSETS= [957](#)
 BUFSIZE= [448](#), [461](#), [471](#)
 CCTVCAN= [526](#)
 CFIRLM= [882](#)
 CFNAMES= [882](#)
 CFOSAM= [882](#)
 CFVSAM= [882](#)
 CIOP= [527](#)
 CKPTID= [527](#)
 CL1=,CL2=CL3=,CL4= [527](#)
 CLASS= [527](#)
 CM0ATOQ= [917](#)
 CMDMCS= [528](#)
 CMDP= [529](#)
 CMDSEC= [728](#)
 CNBA= [968](#)
 CODE= [469](#), [498](#)
 COMPT= [465](#), [471](#)
 COMPT1= [471](#)
 COMPT2= [471](#)
 COMPT3= [471](#)
 COMPT4= [471](#)
 COMPTn= [819](#)
 CONVTYPE= [728](#)
 COPYLOG= [409](#)
 CORE= [529](#)
 CPLOG= [529](#)
 CPUTIME= [530](#)
 CQS= [855](#)
 CQSSN= [855](#)
 CRC= [530](#)
 CSAPSB= [531](#)
 CSLG= [531](#)
 CSLT= [875](#)
 DB= [957](#), [964](#), [966](#)
 DBBF= [531](#)
 DBCTLID= [968](#)
 DBD= [417](#), [532](#), [726](#), [869](#)
 DBFP= [532](#)
 DBFX= [533](#)
 DBLDL= [533](#)
 DBRC= [427](#), [533](#)
 DBRCGRP= [534](#)
 DBRCNM= [187](#), [427](#), [534](#)
 DBRSE= [534](#)

parameters (continued)

DBWP= [534](#)
 DC= [534](#)
 DCLWA= [427](#), [498](#)
 DD= [957](#)
 DDNAME= [450](#), [461](#), [880](#), [968](#)
 DEDBMAS= [861](#)
 DEFERFIX= [836](#)
 DESC= [427](#), [536](#)
 DIAG= [875](#)
 DIRCA= [536](#)
 DISP= [875](#)
 DL/I= [875](#)
 DLINM= [427](#), [537](#)
 DLIPSB= [537](#)
 DLOG= [876](#)
 DLQT= [537](#)
 DMB= [538](#)
 DMHVF= [538](#)
 DPRTY= [538](#)
 DSCT= [538](#)
 DSETS= [453](#)
 DSNAME= [968](#)
 DUMP= [876](#)
 DUMPIO= [876](#)
 DYNP= [538](#)
 EDIT= [450](#), [465](#), [471](#), [498](#), [514](#), [819](#)
 EDTNAME= [410](#)
 EMHB= [539](#)
 EMHL= [539](#)
 ENVIRON= [539](#)
 EPCB= [539](#)
 ERPKPSES= [736](#)
 ETO= [540](#)
 ETOFEAT= [427](#)
 EVAL= [957](#)
 EXCPVR= [540](#)
 EXIT= [917](#)
 EXVR= [540](#)
 F= [726](#)
 FAST= [876](#)
 FBP= [540](#)
 FDRMBR= [540](#)
 FEAT= [450](#), [471](#), [819](#)
 FESEXIT= [410](#)
 FESTIM= [541](#)
 FIX= [541](#)
 FIXBLOCK= [863](#)
 FIXDATA= [863](#)
 FIXINDEX= [863](#)
 FMID= [541](#)
 FMTO= [541](#)
 FP= [542](#)
 FPATH= [404](#), [498](#)
 FPBOF= [968](#)
 FPBUF= [471](#), [968](#)
 FPOPN= [542](#)
 FPRLM= [543](#)
 FPTT= [876](#)
 FPWP= [543](#)
 FRE= [543](#)
 FUNCLV= [968](#)
 GEN= [543](#)
 GENSNAP= [968](#)

parameters (continued)

GPSB= [404](#)
 GRAFFIN= [736](#)
 GRESTAE= [736](#)
 GRMESTAE= [736](#)
 GRNAME= [544](#)
 GRSNAME= [544](#)
 HIOP= [544](#)
 HLQ= [973](#)
 HSB= [427](#)
 HSBID= [544](#)
 HSBMBR= [545](#)
 HSn= [864](#)
 IC= [965](#), [967](#)
 ICOMPT= [465](#)
 IDCO= [876](#)
 IMS= [545](#)
 IMSGROUP= [545](#)
 IMSID= [427](#), [545](#)
 IMSPLEX= [437](#), [546](#), [728](#), [911](#)
 IMSWT= [736](#)
 IN= [546](#)
 INQ= [498](#)
 INQUIRY= [469](#), [498](#)
 IOB= [546](#)
 IOVFI= [546](#)
 IRLM= [427](#), [547](#)
 IRLMGRP= [547](#)
 IRLMID= [547](#)
 IRLNM= [427](#), [547](#)
 ISIS= [548](#)
 ISSUE681= [876](#)
 ISSUE840= [877](#)
 JCL= [437](#)
 JOBCTL= [437](#)
 JVMOPWKR= [550](#)
 JVMOPMAS= [549](#)
 KEEPAV= [917](#)
 KEYEVENT= [836](#)
 LANG= [405](#)
 LATC= [877](#)
 LGMSGSZ= [550](#)
 LGNR= [550](#)
 LHTS= [550](#)
 LIT= [329](#)
 LKPRT= [437](#)
 LKRGN= [437](#)
 LKSIZE= [437](#)
 LNK= [836](#)
 LOCK= [877](#)
 LOCKMAX= [550](#)
 LOCKSEC= [736](#)
 LOCKTAB= [551](#)
 LOG= [836](#), [880](#)
 LOGA= [551](#)
 LOGT= [551](#)
 LSO= [551](#)
 LTE= [551](#)
 LTERM= [471](#), [552](#)
 LUMC= [552](#)
 LUMI= [877](#)
 LUMP= [552](#)
 LUNAME= [728](#)
 MACLIB=

parameters (continued)

MACLIB= (continued)
 IMSPLEX= parameter [437](#)
 MACSYS= [437](#)
 max communication retry [911](#)
 MAXCLAS= [427](#)
 MAXCSA= [553](#)
 MAXIO= [427](#)
 MAXPST= [553](#)
 MAXREGN= [427](#)
 MAXRGN= [498](#)
 MAXSB= [871](#)
 MAXTHRD= [968](#)
 MAXUSRS= [554](#)
 MBR_CORE_MAX= [911](#)
 MBR= [554](#)
 MCS= [427](#), [554](#)
 MFSDfmt= [437](#)
 MFSEXIT= [410](#)
 MFSPpDEF= [736](#)
 MFSTEST= [437](#)
 MINTHRD= [968](#)
 MNPS= [555](#), [838](#)
 MNPSPW= [555](#), [838](#)
 MOD= [555](#)
 MODBLKS= [427](#)
 MODE= [498](#), [728](#)
 MODEL= [471](#)
 MODEtbl= [457](#), [461](#), [471](#)
 MODGEN= [437](#)
 MON= [555](#)
 MRQPSBN= [453](#)
 MSCSEC= [736](#)
 MSCT= [877](#)
 MSCVGR= [736](#)
 MSDB= [556](#)
 MSDBABND= [726](#)
 MSG= [556](#)
 MSGDEL= [470](#), [471](#)
 MSGQ= [856](#)
 MSGTYPE= [498](#)
 MSPLINK= [457](#)
 MSVERIFY= [427](#)
 MSVID= [427](#)
 MTOUSID= [736](#)
 NAME= [461](#), [470](#), [471](#)
 NAMECHK= [427](#)
 NBA= [556](#)
 NBRSEGS= [726](#)
 NHTS= [557](#)
 NLXB= [557](#)
 no longer supported
 AOEXIT= [408](#)
 NODE= [437](#)
 NOIC= [965](#)
 NOPROCH= [965](#)
 NUC= [834](#)
 NUCLEUS= [427](#)
 OBA= [557](#)
 OBJDSET= [437](#)
 obsolete
 PASSWD [562](#)
 OCMD= [877](#)
 ODBASE= [557](#)

parameters (*continued*)

ODBMCFG= [558](#)
ODBMINIT= [558](#)
ODBMNAME= [558](#)
OLC= [728](#)
OLCSTAT= [728](#)
OMPROC= [728](#)
ON-LINE= [427](#)
ONEJOB= [437](#)
OPT= [559](#)
OPTIONS= [411](#), [457](#), [461](#), [471](#), [514](#), [820](#),
[824](#)
ORS= [559](#)
ORSMBR= [559](#)
ORTT= [877](#)
OTHR= [559](#)
OTMA= [559](#)
OTMANM= [561](#)
OTMASE= [561](#)
OTMASP= [562](#)
OTMT= [878](#)
OUT= [562](#)
OUTBND= [728](#), [736](#)
OUTBUF= [471](#), [820](#)
OUTPUT= [465](#)
OVLA= [562](#)
PAGES= [562](#)
PARDLI= [562](#)
PARLIM= [498](#)
PARTNER= [457](#)
PASSWD= [412](#), [562](#)
PASSWD1= [562](#)
PCB= [563](#), [957](#), [964](#), [966](#)
PGMTYPE= [405](#)
PGPROT= [563](#)
PIINCR= [563](#)
PIMAX= [564](#)
PMTO= [736](#)
PMTO1-8= [736](#)
PMTOG= [736](#)
POOLID= [862](#)
PRDR= [564](#)
PREINIT= [564](#)
PREMSG= [564](#)
primary RS catalog repository index [911](#)
primary RS catalog repository member [911](#)
PRLD= [565](#)
procedures
ALOT= [521](#)
ALTID= [521](#)
AOI1= [521](#)
AOIP= [522](#)
AOIS= [522](#)
APAR= [522](#)
APARM= [522](#)
APPC= [523](#)
APPCSE= [523](#)
APPLFE= [523](#)
APPLID1= [524](#)
APPLID2= [524](#)
ARMRST= [524](#)
ASOT= [525](#)
AUTO= [525](#)
BKO= [525](#)

parameters (*continued*)

procedures (*continued*)

BPECFG= [525](#)
BPEINIT= [526](#)
BSIZ= [526](#)
BUF= [526](#)
CCTCVCAN= [526](#)
CIOP= [527](#)
CKPTID= [527](#)
CL1=,CL2=,CL3=,CL4= [527](#)
CLASS= [527](#)
CMDLANG= [527](#)
CMDMCS= [528](#)
CMDP= [529](#)
CMDSEC= [529](#)
CORE= [529](#)
CPLOG= [529](#)
CPUTIME= [530](#)
CRC= [530](#)
CSAPSB= [531](#)
CSLG= [531](#)
CSSLIB= [531](#)
DBBF= [531](#)
DBD= [532](#)
DBFP= [532](#)
DBFX= [533](#)
DBLDL= [533](#)
DBRC= [533](#)
DBRCGRP= [534](#)
DBRCINIT= [534](#)
DBRCNM= [534](#)
DBRSE= [534](#)
DBWP= [534](#)
DC= [534](#)
DEADLOK= [535](#)
DESC= [536](#)
DFSDF= [536](#)
DIRCA= [536](#)
DLINM= [537](#)
DLIPSB= [537](#)
DLQT= [537](#)
DMB= [538](#)
DMHVF= [538](#)
DPRTY= [538](#)
DSCT= [538](#)
DYNP= [538](#)
EMHB= [539](#)
EMHL= [539](#)
ENVIRON= [539](#)
EPCB= [539](#)
ETO= [540](#)
EXCPVR= [540](#)
EXVR= [540](#)
FBP= [540](#)
FDRMBR= [540](#)
FESEXIT= [540](#)
FESTIM= [541](#)
FIX= [541](#)
FMID= [541](#)
FMTO= [541](#)
FP= [542](#)
FPOP= [542](#)
FPRLM= [543](#)
FPWP= [543](#)

parameters (continued)
procedures (continued)

FRE= [543](#)
GEN= [543](#)
GRNAME= [544](#)
GRSNAME= [544](#)
HIOP= [544](#)
HSBID= [544](#)
HSBMBR= [545](#)
IMS= [545](#)
IMSGROUP= [545](#)
IMSID= [545](#)
IMSPLEX= [546](#)
IN= [546](#)
IOB= [546](#)
IOVFI= [546](#)
IRLM= [547](#)
IRLMGRP= [547](#)
IRLMID= [547](#)
IRLMNM= [547](#)
ISIS= [548](#)
JVM= [548](#)
JVMOPMAS= [549](#)
JVMOPWKR= [550](#)
LGMSGSZ= [550](#)
LGNR= [550](#)
LHTS= [550](#)
LOCKMAX= [550](#)
LOCKTAB= [551](#)
LOGA= [551](#)
LOGT= [551](#)
LSO= [551](#)
LTE= [551](#)
LTERM= [552](#)
LUMC= [552](#)
LUMP= [552](#)
MACSYS= [553](#)
MAXCSA= [553](#)
MAXPST= [553](#)
MAXTHRD= [553](#)
MAXUSRS= [554](#)
MBR= [554](#)
MCS= [554](#)
MFSEXITF= [554](#), [575](#)
MFSEXITS= [554](#)
MINTHRD= [555](#)
MNPS= [555](#)
MNPSPW= [555](#)
MOD= [555](#)
MON= [555](#)
MSC= [556](#)
MSDB= [556](#)
MSG= [556](#)
NBA= [556](#)
NHTS= [557](#)
NLXB= [557](#)
NODE1= [557](#)
NODE2= [557](#)
OBA= [557](#)
ODBASE= [557](#)
ODBMCFG= [558](#)
ODBMINIT= [558](#)
ODBMNAME= [558](#)
OMINIT= [558](#)

parameters (continued)
procedures (continued)

OMNAME= [558](#)
OPT= [559](#)
ORS= [559](#)
ORSMBR= [559](#)
OTHR= [559](#)
OTMA= [559](#)
OTMAASY= [560](#)
OTMAMD= [561](#)
OTMANM= [561](#)
OTMASE= [561](#)
OTMASP= [562](#)
OUT= [562](#)
OVLA= [562](#)
PAGES= [562](#)
PARDLI= [562](#)
PASSWD= [562](#)
PASSWD1= [562](#)
PC= [563](#)
PCB= [563](#)
PGPROT= [563](#)
PIINCR= [563](#)
PIMAX= [564](#)
PRDR= [564](#)
PREINIT= [564](#)
PREMSG= [564](#)
PRLD= [565](#)
PSB= [565](#)
PSBW= [565](#)
PST= [566](#)
PSWDC= [566](#)
PWFI= [566](#)
QBUF= [567](#)
QBUFHITH= [567](#)
QBUFLWTH= [567](#)
QBUFMAX= [567](#)
QBUFPCTX= [568](#)
QBUFSZ= [568](#)
QTL= [568](#)
QTU= [569](#)
RC= [569](#)
RCF= [569](#)
RCFTCB= [570](#)
RCLASS= [570](#)
RDMNM= [570](#)
RDS= [570](#)
READNUM= [571](#)
RECA= [571](#)
RECASZ= [571](#)
RES= [571](#)
REST= [571](#)
RGN= [571](#)
RGSUF= [571](#)
RMINIT= [571](#)
RMNAME= [572](#)
RRS= [572](#)
RST= [572](#)
RVFY= [572](#)
SAV= [572](#)
SCEERUN= [573](#)
SCIINIT= [573](#)
SCINAME= [573](#)
SCOPE= [573](#)

parameters (continued)

procedures (continued)

SGN= 573
SGNGENRC= 574
SHAREDQ= 574
SHMSGSZ= 575
SOD= 575
SOUT= 575
SPAP= 576
SPIE= 576
SPM= 576
SRCH= 576
SSM= 576
STIMER= 577
SUF= 578
SVC2= 578
SVSODR= 578
SWAP= 579
SYS= 579
SYS1= 579
SYS2= 580
SYSID= 579
T= 580
TCORACF= 580
TEST= 580
TLIM= 580
TRACE= 580
TRN= 581
TSR= 581
UHASH= 581
UHTS= 581
USERMSGs= 581
USERVAR= 582
VALCK= 582
VAUT= 582
VFREE= 582
VSFX= 582
VSPEC= 582
WKAP= 583
XPLINK= 583
YEAR4= 583
PROCLIB= 437
PROCLIM= 498
PRTY= 437, 498
PSB= 406, 565, 957
PSBW= 565
PSDEPAB= 838
PST= 566
PSTIMER= 736
PSWDC= 566
PTRSIZE= 471, 820
PU= 471
PWF= 566
QBUF= 567
QBUFHITH= 567, 568
QBUFLWTH= 567
QBUFMAX= 567
QBUIFSZ= 568
QMGR= 878
QTL= 187, 568
QTU= 187, 569
RACFMSG= 736
RC= 569
RCF= 569

parameters (continued)

RCFTCB= 570
RCLASS= 570, 736
RCVYCONV= 736, 825
RCVYFP= 749, 825
RCVYRESP= 736
RCVYSTSN= 736, 825
RDMNM= 570
RDS= 838
READNUM= 571
RECA= 571
RECANY= 412
RECAZ= 571
RECLNG= 453
RES= 571
RESIDENT= 416
REST= 571
RGN= 571
RGSUF= 571
RMENV= 728
RNR= 736
ROUTING= 498
RRST= 878
RSENAME= 838
RSNAME= 911
RST= 572
RVFY= 572
SAF_CLASS= 911
SAPPLID= 736
SAV= 572
SBBUF= 957
SBBUFCB= 957
SBONLINE= 871
SCEERUN= 437
SCHD= 498, 878
SCHDTYP= 407
SCIPROC= 728
SCL= 437
SCOPE= 573
SECCNT= 414, 437, 736
secondary RS catalog repository index 911
secondary RS catalog repository member 911
SECT= 878
SEGNO= 498
SEGSIZE= 471, 498, 821
SERIAL= 498
SESSION= 461, 471
SGN= 573
SGNGENRC= 574
SHAREDQ= 574
SHMSGSZ= 575
SHUTDOWN= 453
SIDE= 728
SIGNON= 736
SIMEXIT= 414
SIZE= 471
SLU2= 736
SMFINTERVAL= 843
SMTO= 736
SMTO1-8= 736
SMTOG= 736
SMTOUSID= 736
SOD= 575, 968

parameters (*continued*)

SOUT= [575](#)
SPA= [498](#)
SPAP= [576](#)
SPIE= [576](#)
SPM= [576](#)
SQGROUP= [856](#)
SQTT= [878](#)
SRCH= [576](#)
SRMDEF= [736](#), [826](#)
SSM= [576](#)
START= [880](#), [957](#)
STIMER=
 message-driven programs [577](#)
STM= [736](#)
STOP= [880](#), [957](#)
STRG= [878](#)
STRINGNM= [863](#)
SUBS= [879](#)
SUF= [578](#)
SUFFIX= [437](#)
SURV= [838](#)
SVC2= [578](#)
SWAP= [579](#)
SWITCH= [839](#)
SYNCLEVEL= [728](#)
SYS= [579](#)
SYS1= [579](#)
SYS2= [580](#)
SYSID= [406](#), [460](#), [498](#), [579](#)
SYSMSG= [437](#)
SYSTEM= [427](#)
T= [580](#)
TCORACF= [580](#)
TCPIP [917](#)
TERM= [437](#)
TEST= [580](#)
TIMEOUT= [968](#)
TIMER= [968](#)
TLIM= [580](#)
TMINAME= [427](#)
TPNAME= [728](#)
TRACE= [580](#)
TRN= [581](#)
TRUNC= [736](#)
TSR= [581](#)
TYPE= [329](#), [461](#), [465](#), [471](#)
UHASH= [581](#)
UHTS= [581](#)
UJCL1= [437](#)
UJCL2= [437](#)
UJCL3= [437](#)
UJCL4= [437](#)
UJCL5= [437](#)
UJCLx= [437](#)
UMAC0= [437](#)
UMAC1= [437](#)
UMAC2= [437](#)
UMAC3= [437](#)
UNIT= [471](#), [821](#)
UNITYPE= [450](#), [514](#), [821](#)
UOM= [728](#)
UPDTPRT= [437](#)
USERID= [968](#)

parameters (*continued*)

USERLIB= [437](#)
USERVAR= [582](#), [839](#)
VACBOPN= [736](#)
VALCK= [582](#)
VAUT= [582](#)
VFREE= [582](#)
VSAM_BUFNO= [911](#)
VSAM_BUFSIZE= [911](#)
VSFX= [582](#)
VSPEC= [582](#)
WADS= [187](#)
WARNINC [917](#)
WARNSOC [917](#)
WFI= [498](#)
WKAP= [583](#)
WTORUSID= [736](#)
XCF_GROUP_NAME= [911](#)
XCF_THREADS= [911](#)
XPLINK= [583](#)
YEAR4= [583](#)
parameters specifying IMS [591](#)
PARDLI= parameter [562](#)
PARDLI= parameter for procedures [562](#)
PARLIM= parameter [498](#)
PARM1= and PARM2= on EXEC statement [182](#)
partitioned data set. [131](#)
partitions
 DFSHALDB ddname [218](#)
 HALDB control statement [218](#)
 selective partition processing [218](#)
PARTNER= parameter [457](#)
passtickets, using instead of passwords [736](#)
PASSWD= parameter [412](#), [562](#)
PASSWD= parameter for procedures [562](#)
PASSWD1= parameter [562](#)
PASSWD1= parameter for procedures [562](#)
PC= parameter for procedures [563](#)
PCB= parameter [563](#), [957](#), [964](#), [966](#)
PCB= parameter for procedures [563](#)
PDS (partitioned data set)
 used online [143](#)
PDSE resource restrictions [139](#), [166](#)
performance
 parameters for [180](#)
performance-related EXEC parameters [189](#)
PGMTYPE= parameter [405](#)
PGPROT= parameter [563](#)
PGPROT= parameter for procedures [563](#)
PI (program isolation)
 with PROCOPT=GO option [124](#)
PIINCR= parameter [563](#)
PIINCR= parameter for procedures [563](#)
PIMAX= parameter [564](#)
PIMAX= parameter for procedures [564](#)
PL/I
 data conversion
 from XML [303](#)
 XML-to-PL/I conversion support
 configuring [303](#)
 example [303](#)
 prerequisites [303](#)
 restrictions [303](#)
PL/I modules

PL/I modules (*continued*)

- organizing [211](#)
- PL/I Optimizer [211](#)
- planning
 - scheduling algorithm [116](#)
- PLEX
 - OM trace table type [665](#)
 - RM trace table type [665](#)
 - SCI trace table type [665](#)
- PMTO= parameter [736](#)
- PMTO1-8= parameter [736](#)
- PMTOG= parameter [736](#)
- POOLID= parameter [862](#)
- port
 - configuration examples [917](#)
- positional
 - supported in SSM member of the IMS PROCLIB data set [327](#)
- PPT
 - updating [25](#)
- PPUR= control statement [886](#)
- PRDR= parameter [564](#)
- PRDR= parameter for procedures [564](#)
- PREINIT= parameter [564](#)
- PREINIT= parameter for procedures [564](#)
- preinitialization routines, specifying in DFSHSBxx [839](#)
- PREMSG= parameter [564](#)
- PREMSG= parameter for procedures [564](#)
- preprocessor
 - executing [19](#)
 - exit routines [19](#)
 - JCL [19](#)
 - resource names
 - verified [17](#)
 - storage requirements, estimating [18](#)
- preprocessor for system definition [17](#)
- primary RS catalog repository index parameter [911](#)
- primary RS catalog repository member parameter [911](#)
- PRLD= parameter [565](#)
- PRLD= parameter for procedures [565](#)
- procedure
 - IMSDALOC [654](#)
- procedures
 - alphabetic listing [517](#)
 - cataloged [517](#)
 - DBBBATCH [601](#)
 - DBC [604](#)
 - DCC [611](#)
 - DD statements
 - DFSCTL [583](#)
 - DFSDB2AF [584](#)
 - DFSESL [584](#)
 - DFSHALDB [584](#)
 - DFSOLPnn [584](#)
 - DFSOLSnn [584](#)
 - DFSRESLB [584](#)
 - DFSSTAT [584](#)
 - DFSTCF [585](#)
 - DFSURWF1 [585](#)
 - DFSVSAMP [585](#)
 - DFSWADSn [585](#)
 - FORMATA [585](#)
 - FORMATB [585](#)
 - FPTRACE [585](#)

procedures (*continued*)

DD statements (*continued*)

- IEFRDER [586](#)
- IEFRDER2 [586](#)
- IMS [586](#)
- IMSACB [586](#)
- IMSACBA [586](#)
- IMSACBB [586](#)
- IMSIRD [586](#)
- IMSLOGR [586](#)
- IMSMON [586](#)
- IMSRDS [587](#)
- IMSRDS2 [587](#)
- IMSTFMTA [587](#)
- IMSTFMTB [587](#)
- INPARMS [587](#)
- JAVAERR [587](#)
- JAVAOUT [587](#)
- JCLOUT [587](#)
- JCLPDS [587](#)
- LGMSG [587](#)
- LGMSGL [587](#)
- MODBLKSA [587](#)
- MODBLKSB [587](#)
- MODSTAT [588](#)
- MODSTAT2 [588](#)
- MSDBCP1 [588](#)
- MSDBCP2 [588](#)
- MSDBCP3 [588](#)
- MSDBCP4 [588](#)
- MSDBDUMP [588](#)
- MSDBINIT [588](#)
- OLCSTAT [588](#)
- PRINTDD [589](#)
- PROCLIB [589](#)
- QBLKS [589](#)
- QBLKSL [589](#)
- RECONn [589](#)
- SHMSG [589](#)
- SHMSG [589](#)
- SHMSG [589](#)
- STDENV [589](#)
- STDIN [590](#)
- STEPLIB [590](#)
- SYSABEND [590](#)
- SYSHALDB [590](#)
- SYSIN [590](#)
- SYSLIB [590](#)
- SYSLIN [590](#)
- SYSMOD [590](#)
- SYSPRINT [590](#)
- SYSPRT [590](#)
- SYSUDUMP [590](#)
- SYSUTn [590](#)
- DFSASNO [619](#)
- DFSJBP [621](#)
- DFSMPR [626](#)
- DLIBATCH [628](#)
- DLISAS [631](#)
- FDR [634](#)
- FPUTIL [638](#)
- IMS [639](#)
- IMSBATCH [648](#)
- IMSCOBGO [650](#)
- IMSCOBOL [653](#)

procedures (continued)

IMSCOBOL procedure
description [653](#)

IMSFP [656](#)

IMSPLI [657](#)

IMSPLIGO [659](#)

IMSRDR [661](#)

parameters

ABND= [521](#)

ABND= through AUTO= [520](#)

AGN= [521](#)

ALOT= [521](#)

ALTID= [521](#)

AOI1= [521](#)

AOIP= [522](#)

AOIS= [522](#)

APAR= [522](#)

APARM= [522](#)

APPC= [523](#)

APPCSE= [523](#)

APPLFE= [523](#)

APPLID1= [524](#)

APPLID2= [524](#)

ARMRST= [524](#)

ASOT= [525](#)

AUTO= [525](#)

BKO= [525](#)

BKO= through CSLG= [525](#)

BPECFG= [525](#)

BPEINIT= [526](#)

BSIZ= [526](#)

BUF= [526](#)

CCTCVCAN= [526](#)

CIOP= [527](#)

CKPTID= [527](#)

CL1=,CL2=,CL3=,CL4= [527](#)

CLASS= [527](#)

CMDLANG= [527](#)

CMDMCS= [528](#)

CMDP= [529](#)

CMDSEC= [529](#)

CORE= [529](#)

CPLOG= [529](#)

CPUTIME= [530](#)

CRC= [530](#)

CSAPSB= [531](#)

CSLG= [531](#)

CSSLIB= [531](#)

DBBF= [531](#)

DBBF= through DIRCA= [531](#)

DBD= [532](#)

DBFP= [532](#)

DBFX= [533](#)

DBLDL= [533](#)

DBRC= [533](#)

DBRCGRP= [534](#)

DBRCINIT= [534](#)

DBRCNM= [534](#)

DBRSE= [534](#)

DBWP= [534](#)

DC= [534](#)

DEADLOK= [535](#)

DESC= [536](#)

DFSDF= [536](#)

procedures (continued)

parameters (continued)

DIRCA= [536](#)

DLINM= [537](#)

DLINM= through EXVR= [537](#)

DLIPSB= [537](#)

DLQT= [537](#)

DMB= [538](#)

DMHVF= [538](#)

DPRTY= [538](#)

DSCT= [538](#)

DYNP= [538](#)

EMHB= [539](#)

EMHL= [539](#)

ENVIRON= [539](#)

EPCB= [539](#)

ETO= [540](#)

EXCPVR= [540](#)

EXVR= [540](#)

FBP= [540](#)

FBP= through HSBMBR= [540](#)

FDRMBR= [540](#)

FESEXIT= [540](#)

FESTIM= [541](#)

FIX= [541](#)

FMID= [541](#)

FMTO= [541](#)

FPOPN= [542](#)

FPRLM= [543](#)

FPWP= [543](#)

FRE= [543](#)

GEN= [543](#)

GRNAME= [544](#)

GRSNAME= [544](#)

HIOP= [544](#)

HSBID= [544](#)

HSBMBR= [545](#)

IMS= [545](#)

IMS= through LHTS= [545](#)

IMSGROUP= [545](#)

IMSID= [545](#)

IMSPLEX= [546](#)

IN= [546](#)

IOB= [546](#)

IOVFI= [546](#)

IRLM= [547](#)

IRLMGRP= [547](#)

IRLMID= [547](#)

IRLMNM= [547](#)

ISIS= [548](#)

JVM= [548](#)

JVMOPMAS= [549](#)

JVMOPWKR= [550](#)

LGMSGSZ= [550](#)

LGNR= [550](#)

LHTS= [550](#)

LOCKMAX= [550](#)

LOCKMAX= through MNPSPW= [550](#)

LOCKTAB= [551](#)

LOGA= [551](#)

LOGT= [551](#)

LSO= [551](#)

LTE= [551](#)

LTERM= [552](#)

procedures (continued)

parameters (continued)

LUMC= 552
LUMP= 552
MACSYS= 553
MAXCSA= 553
MAXPST= 553
MAXTHRD= 553
MAXUSRS= 554
MBR= 554
MCS= 554
MINTHRD= 555
MNPS= 555
MNPSPW= 555
MOD= 555
MOD= through ORSMBR= 555
MON= 555
MSC= 556
MSDB= 556
MSG= 556
NBA= 556
NHTS= 557
NLXB= 557
NODE1= 557
NODE2= 557
OBA= 557
ODBASE= 557
ODBMCFG= 558
ODBMINIT= 558
ODBMNAME= 558
OMINIT= 558
OMNAME= 558
OPT= 559
ORS= 559
ORSMBR= 559
OTHR= 559
OTHR= through PIMAX= 559
OTMA= 559
OTMAASY= 560
OTMAMD= 561
OTMANM= 561
OTMASE= 561
OTMASP= 562
OUT= 562
OVLA= 562
PAGES= 562
PARDLI= 562
PASSWD= 562
PASSWD1= 562
PC= 563
PCB= 563
PGPROT= 563
PIINCR= 563
PIMAX= 564
PRDR= 564
PRDR= through QTU= 564
PREINIT= 564
PREMSG= 564
PRLD= 565
PSB= 565
PSBW= 565
PST= 566
PSWDC= 566
PWFI= 566

procedures (continued)

parameters (continued)

QBUF= 567
QBUFHITH= 567
QBUFLWTH= 567
QBUFMAX= 567
QBUFPCPX= 568
QBUNFSZ= 568
QTL= 568
QTU= 569
RC= 569
RC= through RVFY= 569
RCF= 569
RCFTCB= 570
RCLASS= 570
RDMNM= 570
RDS= 570
READNUM= 571
RECA= 571
RECA SZ= 571
RES= 571
REST= 571
RGN= 571
RGSUF= 571
RMINIT= 571
RMNAME= 572
RRS= 572
RST= 572
RVFY= 572
SAV= 572
SAV= through SUF= 572
SCEERUN= 573
SCIINIT= 573
SCINAME= 573
SCOPE= 573
SGN= 573
SGNGENRC= 574
SHAREDQ= 574
SHMSG SZ= 575
SOD= 575
SOUT= 575
SPAP= 576
SPIE= 576
SPM= 576
SRCH= 576
SSM= 576
STIMER= 577
SUF= 578
SVC2= 578
SVC2= through TLIM= 578
SVSODR= 578
SWAP= 579
SYS= 579
SYS1= 579
SYS2= 580
SYSID= 579
T= 580
TCORACF= 580
TEST= 580
TLIM= 580
TRACE= 580
TRACE= through YEAR4= 580
TRN= 581
TSR= 581

procedures (*continued*)

- parameters (*continued*)
 - UHASH= [581](#)
 - UHTS= [581](#)
 - USERVAR= [582](#)
 - VALCK= [582](#)
 - VAUT= [582](#)
 - VFREE= [582](#)
 - VSFX= [582](#)
 - VSPEC= [582](#)
 - WKAP= [583](#)
 - XPLINK= [583](#)
 - YEAR4= [583](#)
- RDIBATCH [662](#)
- Repository Server [664](#)
- storing [517](#)

processing options, as part of scheduling [117](#)

PROCLIB

- CQSIPxxx [245](#)
- DFSCDxxx [245](#)
- DFSCGxxx [245](#)
- EXITMBR parameter [665](#)
- external subsystem member [327](#)
- members
 - BPE [245](#)
- positional parameters supported [327](#)
- STATINTV parameter [665](#)

PROCLIB members

- DFSDSCMx [815](#)
- DFSDSCTy [827](#)
- DFSYDTx (OTMA) [888](#)
- ETO
 - DFSDSCMx [815](#)
 - DFSDSCTy [827](#)
 - OTMA DFSYDTx [888](#)

PROCLIB= parameter [437](#)

PROCLIM= parameter [498](#)

program modules, making high-use resident [845](#)

Program Properties Table (PPT) for z/OS

- entries for Base Primitive Environment [25](#)
- entries for Common Queue Server [25](#)
- entries for Common Service Layer [25](#)
- entries for IMS Connect [25](#)
- entries for IMS control region [25](#)
- entries for IRLM [25](#)

program scheduling

- for BMPs [124](#)
- into message classes [118](#)
- message priorities [118](#)

program specification block (PSB)

- abend U3303 [122](#)
- stopped due to 10 U3303 abends [122](#)

program specification blocks (PSBs)

- defining program views
 - application control blocks (ACBs), managing [252](#)
 - IMS catalog [262](#), [274](#)

program views

- defining
 - application control blocks (ACBs), managing [252](#)

programs

- application, characteristics of [109](#)
- online, declaring [109](#)
- scheduling CPI-communications-driven [125](#)

provisioning

provisioning (*continued*)

- databases
 - Fast Path DEDB [236](#)
 - IBM z/OS Management Facility
 - Fast Path DEDB [236](#)
 - IMS resources [235](#)
 - IMS systems [235](#)
- PRTY= parameter [437](#), [498](#)
- PSB
 - pools
 - defining [105](#)
 - stopping [117](#)
 - PSB (program specification block)
 - abend U3303 [122](#)
 - stopped due to 10 U3303 abends [122](#)
 - PSB performance options
 - dynamic [109](#)
 - PSB pools, defining
 - /DISPLAY POOL PSBP command [105](#)
 - ACBGEN utility [105](#)
 - PSB-related EXEC parameters [189](#), [192](#)
 - PSB= parameter [406](#), [565](#), [957](#)
 - PSB= parameter for procedures [565](#)
 - PSBs (program specification blocks)
 - defining
 - application control blocks (ACBs), managing [252](#)
 - IMS catalog [262](#), [274](#)
 - PSBW= parameter [565](#)
 - PSBW= parameter for procedures [565](#)
 - PSDEPAB= parameter [838](#)
 - PSELNODBRC control statement [887](#)
 - pseudo wait-for-input (PWFI) [121](#)
 - PST= parameter [566](#)
 - PST= parameter for procedures [566](#)
 - PSTIMER= parameter [736](#)
 - PSWDC= parameter [566](#)
 - PSWDC= parameter for procedures [566](#)
 - PTRSIZE= parameter [471](#), [820](#)
 - PU= parameter [471](#)
 - PWFI (pseudo wait-for-input), description [121](#)
 - PWFI= parameter [566](#)
 - PWFI= parameter for procedures [566](#)

Q

- QBUF= parameter [567](#)
- QBUF= parameter for procedures [567](#)
- QBUFHITH= parameter [567](#), [568](#)
- QBUFHITH= parameter for procedures [567](#)
- QBUFLWTH= parameter [567](#)
- QBUFLWTH= parameter for procedures [567](#)
- QBUFMAX= parameter [567](#)
- QBUFMAX= parameter for procedures [567](#)
- QBUFPCIX= parameter for procedures [568](#)
- QBUFSZ= parameter [568](#)
- QBUFSZ= parameter for procedures [568](#)
- QCF (Queue Control Facility)
 - IQMRHO [153](#)
 - migrating messages [153](#)
 - monitoring users [153](#)
 - User Queue Space Notification Exit routine [153](#)
- QMGR= parameter [878](#)
- QTL= parameter [187](#), [568](#)

QTL= parameter for procedures [568](#)
QTU= parameter [187](#), [569](#)
QTU= parameter for procedures [569](#)
Queue Control Facility [153](#)
queue manager
 concurrent I/O
 [153](#)
quick reschedule
 description [120](#)
 specifying [120](#)

R

RACF
 for local option security [300](#)
 passtickets, using [736](#)
RACFMSG= parameter [736](#)
RC= parameter [569](#)
RC= parameter for procedures [569](#)
RCF= parameter [569](#)
RCF= parameter for procedures [569](#)
RCFTCB= parameter [570](#)
RCFTCB= parameter for procedures [570](#)
RCLASS= parameter [570](#), [736](#)
RCLASS= parameter for procedures [570](#)
RCVYCONV= parameter [736](#), [825](#)
RCVYFP= parameter [749](#), [825](#)
RCVYRESP= parameter [736](#)
RCVYSTSN= parameter [736](#), [825](#)
RDDS
 exporting
 MODBLKS descriptor definitions [80](#)
 MODBLKS resource definitions [80](#)
 extraction utility [95](#)
 importing
 descriptor definitions [88](#)
 resource definitions [88](#)
 using IMPORT command [88](#)
 in FDBR region [37](#)
RDDS (resource definition data set)
 allocating [158](#)
RDIBATCH procedure
 DD statements [662](#)
 description [662](#)
 parameters
 APARM= [522](#)
 BKO= [525](#)
 BUF= [526](#)
 CKPTID= [527](#)
 DBRC= [533](#)
 EXCPVR= [540](#)
 FMTO= [541](#)
 IMSID= [545](#)
 IMSPLEX= [546](#)
 IOB= [546](#)
 IRLM= [547](#)
 IRLMNM= [547](#)
 LOCKMAX= [550](#)
 LOGA= [551](#)
 MBR= [554](#)
 MON= [555](#)
 PRLD= [565](#)
 PSB= [565](#)
 RGN= [571](#)

RDIBATCH procedure (*continued*)
 parameters (*continued*)
 RST= [572](#)
 SOUT= [575](#)
 SPIE= [576](#)
 SRCH= [576](#)
 SSM= [576](#)
 SWAP= [579](#)
 SYS= [579](#)
 SYS2= [580](#)
 TEST= [580](#)
RDMNM= parameter [570](#)
RDMNM= parameter for procedures [570](#)
RDS= parameter [838](#)
RDS= parameter for procedures [570](#)
read access to databases [416](#)
read-only access to databases [416](#)
READNUM= parameter [571](#)
READNUM= parameter for procedures [571](#)
RECA= parameter [571](#)
RECA= parameter for procedures [571](#)
RECANY= parameter [412](#)
RECAZ= parameter [571](#)
RECAZ= parameter for procedures [571](#)
RECLNG= parameter [453](#)
recommendations
 checkpoint frequency
 take frequent checkpoints to minimize restart time
 [103](#)
 deadlock frequency
 choose value high enough to resolve deadlocks and
 low enough not to impact performance [535](#)
 choose value low enough not to impact
 performance [535](#)
 deadlocks
 monitor number of deadlocks and adjust local
 deadlock value accordingly [536](#)
 exit routines
 lower-numbered exit routines should be field exit
 routines [410](#)
 lower-numbered exit routines should be segment
 exit routines [410](#)
 Fast Path (FPCTRL macro)
 specify BLOCKS=FP to avoid performance problems
 and system abends [830](#)
 IMS batch [857](#)
 IRLM startup procedures
 specify same value for DEADLOK parameters to
 avoid last IRLM value becoming the value for all [535](#)
 JAVAERR DD statements
 specify to take advantage of function [587](#)
 JAVAOUT DD statements
 specify to take advantage of function [587](#)
 language interface module
 CSECT name [329](#)
 LINEGRP macro
 allocate at least two data sets [450](#)
 security
 protect IMS data sets from unauthorized access by
 using RACF or an equivalent product [381](#)
 use OM (Operations Manager) command security
 rather than IMS security [728](#)
 serviceability

- recommendations (*continued*)
 - serviceability (*continued*)
 - specify ON for the DL/I=, LOCK=, DISP=, and SCHD=parameters [872](#)
 - tracing
 - run the FPTRACE in a test environment only [876](#)
 - transactions
 - use upper-case characters for TPNAMES [728](#)
- RECORDER
 - JCL to print output [308](#)
- Recoverable Resource Manager Services attachment facility (RRSAF) [333](#)
- recovery service
 - IMS PROCLIB data set member (DFSORSxx) [847](#)
- recovery-related EXEC parameters [187](#), [189](#), [192](#)
- region-control EXEC parameters [189](#), [192](#)
- regions
 - FDBR
 - configuration [134](#)
 - online
 - IMS management of ACBs [261](#)
- regions, dependent
 - number of, choosing the [103](#), [427](#), [566](#)
 - preinitialization routines [839](#)
- REPO (repository) [665](#)
- repository (REPO) [665](#)
- repository data sets
 - allocating [160](#)
- Repository Server
 - FRPCFG member of the IMS PROCLIB data set [911](#)
 - set up tracing [345](#)
 - startup procedure [664](#)
- Repository Server trace table types
 - * (asterisk) [665](#)
 - DIAG (diagnostic) [665](#)
- RES= parameter [571](#)
- RES= parameter for procedures [571](#)
- RESIDENT online change [402](#)
- RESIDENT= parameter [416](#)
- resource definition data set
 - in FDBR region [37](#)
- resource definition data set (RDDS)
 - allocating [158](#)
 - changing block size [159](#)
 - exporting
 - MODBLKS descriptor definitions [80](#)
 - MODBLKS resource definitions [80](#)
 - importing
 - descriptor definitions [88](#)
 - resource definitions [88](#)
 - using IMPORT command [88](#)
- resource definitions
 - and IMS cold start [37](#)
 - exporting with DRD [79](#)
 - extraction utility [95](#)
 - importing with DRD [84](#), [88](#)
 - recoverability [37](#)
- resource descriptor definitions
 - creating [53](#)
 - creating in IMSplex [57](#)
 - deleting [69](#)
 - deleting in IMSplex [75](#)
 - updating [61](#)
 - updating in IMSplex [66](#)
- resource lists
 - IMSRSC repository [42](#)
- Resource Manager
 - set up tracing [345](#)
- Resource Manager (RM)
 - initialization parameters
 - IMSRSC repository [719](#)
 - sample CSLRIxxx member [722](#)
 - sample user exit list member of the IMS PROCLIB data set [722](#)
 - startup procedure [598](#)
 - user exit list member of the IMS PROCLIB data set [245](#), [719](#)
- resource name checks [21](#)
- resource name list. [139](#)
- Resource Name table, storage [19](#)
- resource naming
 - rules
 - ETO terminals [395](#)
 - macros [395](#)
 - node names [395](#)
 - subpool names [395](#)
- resource naming rules
 - ETO terminals [395](#)
 - macros [395](#)
- resource structure
 - calculating storage for [237](#)
 - CQS support [245](#)
 - resources that are stored [237](#)
- resources created with IMPORT command
 - backing out [90](#), [91](#)
- REST= parameter [571](#)
- REST= parameter for procedures [571](#)
- restarting IMS
 - checkpoints, using [103](#)
- restrictions
 - defining MSDBs dynamically [54](#)
- RGN= parameter [571](#)
- RGN= parameter for procedures [571](#)
- RGSUF= parameter [571](#)
- RGSUF= parameter for procedures [571](#)
- RM exit routine member of the IMS PROCLIB data set
 - EXITMBR parameter [665](#)
- RM trace table types
 - * (asterisk) [665](#)
 - CSL [665](#)
 - ERR [665](#)
 - PLEX [665](#)
 - recommendations [665](#)
 - REPO (repository) [665](#)
 - RM [665](#)
- RMENV= parameter [728](#)
- RMF
 - accounting procedures [105](#)
- RMINIT= parameter for procedures [571](#)
- RMNAME= parameter for procedures [572](#)
- RMTCICS
 - parameters [938](#)
- RMTCICS configuration statement
 - statement [938](#)
- RMTIMSCON
 - parameters [939](#)
 - statement [939](#)
 - syntax [939](#)

RNL (resource name list) [139](#)
 RNR= parameter [736](#)
 routing codes
 deleting [73](#)
 deleting dynamically [73](#)
 deleting with DRD [73](#)
 ROUTING= parameter [498](#)
 RRS= parameter for procedures [572](#)
 RRSF (Recoverable Resource Manager Services attachment facility) [333](#)
 RRSF= parameter [878](#)
 RS catalog repository data sets
 allocating [161](#)
 RSENAME= parameter [838](#)
 RSNAM= parameter [911](#)
 RST= parameter [572](#)
 RST= parameter for procedures [572](#)
 RTCODE macro
 description [469](#)
 parameters
 CODE= [469](#)
 INQUIRY= [469](#)
 syntax diagram [469](#)
 RTCODE macro statement
 for Fast Path [23](#)
 runtime resource definitions
 creating with DRD [53](#)
 creating with DRD in IMSplex [57](#)
 deleting with DRD [69](#)
 deleting with DRD in IMSplex [75](#)
 updating with DRD [61](#)
 updating with DRD in IMSplex [66](#)
 RVFY= parameter [572](#)
 RVFY= parameter for procedures [572](#)

S

SAF_CLASS= parameter [911](#)
 Sample
 BPE configuration files [665](#)
 BPE user exit list member of the IMS PROCLIB data set [684](#)
 combined user exit list member of the IMS PROCLIB data set [684](#)
 CQS user exit list member of the IMS PROCLIB data set [684](#)
 IMS Connect user exit list member of the IMS PROCLIB data set [684](#)
 OM user exit list member of the IMS PROCLIB data set [684](#)
 RM user exit list member of the IMS PROCLIB data set [684](#)
 SCI user exit list member of the IMS PROCLIB data set [684](#)
 SAPPLID= parameter [736](#)
 SAV, online execution parameter [180](#)
 SAV= parameter [572](#)
 SAV= parameter for procedures [572](#)
 SAVE AS prompt panel
 panel field descriptions [392](#)
 Save Member prompt panel
 panel field descriptions [392](#)
 SBBUF= parameter [957](#)
 SBBUFCB= parameter [957](#)

SBCO [957](#)
 SBESNAP [957](#)
 SBIC [957](#)
 SBONLINE control statement [871](#)
 SBONLINE= parameter [871](#)
 SBPARM [957](#)
 SBSNAP [957](#)
 SCEERUN= parameter [437](#)
 SCEERUN= parameter for procedures [573](#)
 SCHD= parameter [498](#), [878](#)
 SCHDTYP= parameter [407](#)
 scheduling
 CPI-communications-driven programs [125](#)
 parallel [124](#)
 setting processing limits [120](#)
 scheduling algorithm
 developing [116](#)
 SCI exit routine member of the IMS PROCLIB data set
 EXITMBR parameter [665](#)
 SCI trace table types
 * (asterisk) [665](#)
 CSL [665](#)
 ERPL [665](#)
 ERR [665](#)
 INTF [665](#)
 INTP [665](#)
 PLEX [665](#)
 recommendations [665](#)
 SCIINIT= parameter for procedures [573](#)
 SCINAME= parameter for procedures [573](#)
 SCIPROC= parameter [728](#)
 SCL= parameter [437](#)
 SCOPE= parameter [573](#)
 SCOPE= parameter for procedures [573](#)
 screen sizes, relating device names to [497](#)
 SDEP utilities
 discarding preallocated SDEP CIs [887](#)
 SDUMP
 how IRLM uses it [973](#)
 searching for online [619](#)
 SECCNT= parameter [414](#), [437](#), [736](#)
 secondary allocation [345](#)
 secondary indexing
 suppressing index entries [968](#)
 secondary master terminal
 commands that can be copied to [409](#)
 secondary RS catalog repository index parameter [911](#)
 secondary RS catalog repository member parameter [911](#)
 SECT= parameter [878](#)
 Secure Sockets Layer (SSL)
 libraries required for [297](#)
 security
 catalog, IMS [290](#)
 EXEC parameters [189](#), [192](#)
 for local option [300](#)
 IMS catalog [290](#)
 maintenance blocks [131](#)
 specifying options [136](#)
 security support
 IMS Connect [300](#)
 SEGNO= parameter [498](#)
 SEGSIZE= parameter [471](#), [498](#), [821](#)
 selective partition processing
 DFSHALDB ddname [218](#)

selective partition processing (*continued*)
 HALDB control statement [218](#)

separate address space [105](#)

sequential buffering
 control statements, specifying
 SBCO [957](#)
 SBESNAP [957](#)
 SBIC [957](#)
 SBPARAM [957](#)
 SBSNAP [957](#)
 SNAPDEST [957](#)
 online system [871](#)
 OSAM [206](#), [210](#)

SERIAL= parameter [498](#)

serialization
 programs in an IMSplex [704](#)

serviceability and trace options, defining [871](#)

SESSION= parameter [461](#), [471](#)

SETI [968](#)

SETO [964](#)

SETR [966](#)

SETRLIMI [917](#)

setting up IMS for diagnostics [337](#)

SETU [966](#)

SGN= parameter [573](#)

SGN= parameter for procedures [573](#)

SGNGENRC= parameter [574](#)

SGNGENRC= parameter for procedures [574](#)

shared queues
 DFSDFxxx [806](#)
 interface, tracing [878](#)
 managing serialized programs [704](#)

SHAREDQ= parameter [574](#)

SHAREDQ= parameter for procedures [574](#)

Sharing BPE configuration parameters [665](#)

SHMSGSZ= parameter [575](#)

SHMSGSZ= parameter for procedures [575](#)

SHUTDOWN= parameter [453](#)

SIDE= parameter [728](#)

SIGNON= parameter [736](#)

SIMEXIT= parameter [414](#)

SIZE= parameter [471](#)

SLDS (system log data set)
 archiving OLDS [147](#), [148](#)
 creating [152](#)

SLU 1
 TERMINAL macro statement, specifying [471](#)

SLU 2
 TERMINAL macro statement, specifying [471](#)

SLU P
 TERMINAL macro statement, specifying [471](#)

SLU2= parameter [736](#)

SMF
 accounting procedures [105](#)

SMF records
 IMS catalog activity record enhancement [294](#)
 IMS catalog activity records [294](#)
 JVM usage statistics [222](#)
 JVM usage statistics records [223](#)

SMP/E
 used for maintenance [25](#)

SMT0= parameter [736](#)

SMT01-8= parameter [736](#)

SMT0G= parameter [736](#)

SMT0USID= parameter [736](#)

SNAPDEST [957](#)

SOD= parameter [575](#), [968](#)

SOD= parameter for procedures [575](#)

SOUT= parameter
 procedures
 IMSDALOC [654](#)

SOUT= parameter for procedures [575](#)

SPA= parameter [498](#)

space requirements, data sets
 direct output [169](#)
 SYSOUT [166](#)

SPAP= parameter [576](#)

SPAP= parameter for procedures [576](#)

specify exit list member name [665](#)

specify language [665](#)

specify SYSMDUMP statement [339](#)

specify SYSUDUMP statement [339](#)

specify time intervals [665](#)

specify trace level [665](#)

specifying desired trace options [330](#)

specifying security options [136](#)

SPIE= parameter [576](#)

SPIE= parameter for procedures [576](#)

SPM= parameter [576](#)

SPM= parameter for procedures [576](#)

spool
 estimating SYSOUT requirements [166](#)

Spool
 TERMINAL macro statement, specifying [471](#)

spool line group
 logical record length [166](#)
 specifying LINEGRP macro [166](#)

spool SYSOUT data sets [166](#)

SQGROUP= parameter [856](#)

SQTT= parameter [878](#)

SRCH= parameter [576](#)

SRCH= parameter for procedures [576](#)

SRMDEF= parameter [736](#), [826](#)

SSM=
 Db2 for z/OS
 connection parameters [332](#)
 IMS batch regions [332](#)

SSM= parameter [576](#)

SSM= parameter for procedures [576](#)

SSRV (system services trace table) [665](#)

stage 1
 IMS PROCLIB data set updates [198](#)
 input, sequencing [2](#)

stage 1, IMS system definition [20](#)

stage 2, IMS system definition [24](#)

staging libraries [139](#)

START command
 database access, defining [416](#)
 DATABASE macro, ACCESS parameter [416](#)
 dependent regions, starting [103](#)

START= parameter [880](#), [957](#)

starting CQS [242](#)

startup CQS [590](#)

startup procedure
 load repository server from log records [599](#)
 Structured Call Interface [598](#)

static definition
 terminals

- static definition (*continued*)
 - terminals (*continued*)
 - when required [132](#)
- STG (storage service trace table) [665](#)
- STIMER= parameter
 - message-driven programs [577](#)
- STIMER= parameter for procedures [577](#)
- STM= parameter [736](#)
- STOP= parameter [880](#), [957](#)
- storage
 - CQS
 - resource structure [237](#)
 - extended
 - requesting that z/OS use [871](#)
- storage estimates
 - extended private storage [18](#)
- storage pool
 - 64-bit [210](#)
- storage pool definitions
 - default [849](#)
 - DFSSPMxx, overriding defaults [849](#)
- storage service trace table (STG) [665](#)
- STR (structure trace table) [665](#)
- STRG= parameter [878](#)
- STRINGNM= parameter [863](#)
- structure
 - EMHQ (EMH queue)
 - CQSSGxxx [699](#)
 - CQSSLxxx [697](#)
 - disabling [697](#), [699](#)
 - recovery data set, example [590](#)
 - size [237](#)
- structure trace table (STR) [665](#)
- Structured Call Interface
 - set up tracing [345](#)
 - user exits
 - initialization parameters [245](#), [723](#)
- Structured Call Interface (SCI)
 - sample startup procedure [598](#)
 - startup procedure [598](#)
 - user exits
 - List member of the IMS PROCLIB data set [245](#), [724](#)
- SUBPOOL macro
 - description [470](#)
 - LU 6.1 VTAM Devices [470](#)
 - parameters
 - MSGDEL= [470](#)
 - NAME= [470](#)
 - syntax diagram [470](#)
- SUBS= parameter [330](#), [879](#)
- subsystem identification parameters [177](#)
- SUF= parameter [578](#)
- SUF= parameter for procedures [578](#)
- SUFFIX= keyword
 - specifying alternate configurations of online system [22](#)
- SUFFIX= parameter [437](#)
- supporting multiple clients [237](#)
- suppressing index entries [968](#)
- SURV= parameter [838](#)
- suspend queue
 - for scheduling transactions [122](#)
- SVC2= parameter [578](#)
- SVC2= parameter for procedures [578](#)
- SVSODR= parameter for procedures [578](#)
- SWAP= parameter [579](#)
- SWAP= parameter for procedures [579](#)
- SWITCH= parameter [839](#)
- switched communication lines
 - described by LINE macro [448](#)
- SYNLEVEL= parameter [728](#)
- Syntax Checker
 - action pull-down options [389](#)
 - checking parameter values [381](#)
 - display options [385](#)
 - error checking [387](#)
 - function keys [382](#)
 - help information [382](#)
 - IMS PROCLIB data set members [388](#)
 - IMS Release and Control Region panel [384](#)
 - IMS Release panel [384](#)
 - inserting keywords [390](#)
 - interrupting processing [390](#)
 - Keyword Display panel [385](#), [386](#), [389–391](#)
 - online help [382](#)
 - overview [517](#)
 - panel field descriptions [384–386](#), [392](#), [393](#)
 - Parameter Syntax Checker panel [393](#)
 - SAVE AS prompt panel [392](#)
 - Save Member prompt panel [392](#)
 - saving processed members [391](#)
 - starting [382](#)
 - using [383](#)
- syntax diagram
 - how to read [xiii](#)
- SYS= parameter [579](#)
- SYS= parameter for procedures [579](#)
- SYS1= parameter [579](#)
- SYS1= parameter for procedures [579](#)
- SYS2= keyword
 - procedures
 - IMSDALOC [654](#)
- SYS2= parameter [580](#)
- SYS2= parameter for procedures [580](#)
- SYSID= parameter
 - changing [460](#)
 - description [460](#)
- SYSID= parameter for procedures [579](#)
- SYSMDUMP statement
 - specify [339](#)
- SYMSMSG= parameter [437](#)
- SYSOUT
 - estimating spooled requirements [166](#)
- SYSOUT data sets
 - allocation of data sets [166](#)
 - BSAM EXCP use in [166](#)
 - for TSO browsing [166](#)
 - space requirements, data sets [166](#)
- system
 - data sets
 - for online change [139](#)
 - initializing IMS system data sets [139](#)
 - system checkpoint data set example [590](#)
 - system configuration
 - macro statements [371](#)
 - system data sets
 - online change function [139](#)
 - system definition

- system definition (*continued*)
 - allowing for Fast Path [23](#)
 - catalog
 - installing DBDs and PSBs [262](#)
 - DDL
 - data set options [773](#)
 - DFSDFxxx member [773](#)
 - DFSDFxxx
 - DDL section [773](#)
 - examples
 - DB/DC environment [355](#)
 - for a Common Service Layer installation [245](#)
 - high-level view [1](#)
 - how it is related to installation [1](#)
 - IBM z/OS Management Facility [235](#)
 - IMS catalog
 - alias [285](#)
 - data sharing [284](#)
 - DFSDFxxx members in multi-system configurations [285](#)
 - examples of multi-system configurations [287](#)
 - installing DBDs and PSBs [262](#)
 - multi-system configurations [283](#)
 - unregistered catalog [272](#)
 - without DBRC [272](#)
 - IMSCTRL macro [427](#)
 - large system definition
 - storage requirements [18](#)
 - macros
 - maximum occurrences [395](#)
 - MSC
 - DFSDFxxx member [797](#)
 - MSC section [797](#)
 - output from stage 1 [22](#)
 - parameters changing [5](#)
 - preprocessor
 - executing [19](#)
 - large system definition [18](#)
 - standard [18](#)
 - storage requirements, estimating [18](#)
 - procedures
 - environments in which they apply [517](#)
 - required macros for Fast Path [23](#)
 - specifying alternative version [22](#)
 - specifying security options [136](#)
 - supertasks [1](#)
 - type
 - guidelines for selecting [427](#)
 - type of system definition required [5](#)
 - types [22](#)
 - when it is required [22](#)
- system definition macro statements
 - APPLCTN macro, for Fast Path [23](#)
 - RTCODE macro, for Fast Path [23](#)
 - TERMINAL macro, for Fast Path [23](#)
 - TRANSACT macro, for Fast Path [23](#)
- system definition process
 - ALL [2](#)
 - BATCH [2](#)
 - CTLBLKS [2](#)
 - JCLIN process [25](#)
 - MODBLKS [2](#)
 - MSVERIFY [2](#)
 - NUCLEUS [2](#)

- system definition process (*continued*)
 - ON-LINE [2](#)
 - overview of [1](#)
 - SMP/E maintenance [25](#)
 - stage 1 [20](#)
 - stage 2 [24](#)
 - types of [2](#)
- system log data set [147](#)
- system modification program/extended (SMP/E)
 - used for maintenance [25](#)
- system services trace table (SSRV) [665](#)
- system set up
 - BPE external trace [345](#)
 - CQS tracing [345](#)
 - external trace environment [343](#)
 - IMS Connect tracing [345](#)
 - OM tracing [345](#)
 - RM tracing [345](#)
 - RS tracing [345](#)
 - SCI tracing [345](#)
 - specify SYSMDUMP statement [339](#)
 - specify SYSUDUMP statement [339](#)
 - type-2 tracing [347](#)
 - writing trace tables [344](#)
 - z/OS master trace table size [339](#)
- system set up for diagnosis
 - IMS Control Region EXEC [339](#)
- system trace table [339](#)
- System/3
 - LINEGRP macro statement, specifying [450](#)
 - TERMINAL macro statement, specifying [471](#)
- System/7
 - LINEGRP macro statement, specifying [450](#)
 - TERMINAL macro statement, specifying [471](#)
- SYSTEM= parameter [427](#)
- SYSUDUMP statement
 - specify [339](#)

T

- T= parameter [580](#)
- T= parameter for procedures [580](#)
- tables, writing trace [344](#)
- tailoring
 - execution procedures for Fast Path [201](#)
- TCORACF= parameter [580](#)
- TCORACF= parameter for procedures [580](#)
- TCP/IP
 - and creating the IMS Connect configuration member [917](#)
 - and IMS Connect configuration [298](#)
 - connections between IMS systems, defining [311](#)
 - ECB parameter [917](#)
 - IMS-to-IMS TCP/IP communications [311](#)
 - KeepAlive function [917](#)
 - keyword parameters [917](#)
 - local option client communications
 - updates in the z/OS PPT [298](#)
- MSC
 - generic resources, enabling [318](#)
- system definition
 - IMS-to-IMS TCP/IP connections [311](#)

TCP/IP (*continued*)
 user exit message [917](#)
 z/OS Program Properties Table (PPT)
 local option client communication updates [298](#)
 TCP/IP updates [298](#)
 updating [298](#)

TCPIP
 parameters [943](#)
 statement [943](#)
 syntax [943](#)

TERM= parameter [437](#)

terminal devices, allocating in an online system [640](#)

TERMINAL macro
 COMM macro, and [414](#)
 description [471](#)
 label field [471](#)
 MFS [173](#)
 parameters
 BACKUP= [471](#)
 BUFSIZE= [471](#)
 COMPT= [471](#)
 COMPTx= [471](#)
 EDIT= [471](#)
 FEAT= [471](#)
 FPBUF= [471](#)
 LTERM= [471](#)
 MODEL= [471](#)
 MODETBL= [471](#)
 MSGDEL= [471](#)
 NAME= [471](#)
 OPTIONS= [471](#)
 OUTBUF= [471](#)
 PTRSIZE= [471](#)
 PU= [471](#)
 SEGSIZE= [471](#)
 SESSION= [471](#)
 SIZE= [471](#)
 TYPE= [471](#)
 UNIT= [471](#)
 syntax diagram [471](#)

TERMINAL macro statement
 for Fast Path [23](#)

terminal network [131](#)

terminals
 defining [125](#)
 dynamic [132](#)
 dynamic allocation [132](#)
 effect of system definition process on [132](#)
 static [132](#)
 static definition [132](#)

TEST= parameter [580](#)

TEST= parameter for procedures [580](#)

time-of-day clock [153](#)

TIMEOUT= parameter [968](#)

timer
 counting unused IOVF control intervals [546](#)

TIMER= parameter [968](#)

TLIM= parameter [580](#)

TLIM= parameter for procedures [580](#)

TMINAME= parameter [427](#)

TOD clock [153](#)

TPNAME= parameter [728](#)

TRACE command
 DASD log activity, tracing [876](#)

TRACE command (*continued*)
 DB2 subsystem connection, tracing [879](#)
 DBF entries from FP, tracing [876](#)
 dispatcher activity, tracing [875](#)
 DL/I activity, tracing [875](#), [876](#)
 latch activity, tracing [877](#)
 lock activity, tracing [877](#)
 options [875](#)
 OTMA control, tracing [878](#)
 queue manager, tracing [878](#)
 scheduler, tracing [878](#)
 shared queues interface, tracing [878](#)
 storage manager calls, tracing [878](#)

trace entries
 options, defining [871](#)
 storage requirements [879](#)

trace table
 external trace environment
 starting and stopping [343](#)
 sizes
 z/OS master [339](#)
 z/OS system [339](#)

TRACE= parameter [580](#)

TRACE= parameter for procedures [580](#)

traces
 controlling the volume [343](#)
 CQS [345](#)
 Fast Path [344](#)
 IMS Connect [345](#)
 offloading trace data set [344](#)
 OM [345](#)
 RM [345](#)
 RS [345](#)
 SCI [345](#)
 type-2 [347](#)
 writing entries to external data sets [665](#)

trademarks [977](#), [978](#)

TRANSACT macro
 description [498](#)
 parameters
 AOI= [498](#)
 CODE= [498](#)
 DCLWA= [498](#)
 EDIT= [498](#)
 FPATH= [498](#)
 INQ= [498](#)
 INQUIRY= [498](#)
 MAXRGN= [498](#)
 MODE= [498](#)
 MSGTYPE= [498](#)
 PARLIM= [498](#)
 PROCLIM= [498](#)
 PRTY= [498](#)
 ROUTING= [498](#)
 SCHD= [498](#)
 SEGNO= [498](#)
 SEGSIZE= [498](#)
 SERIAL= [498](#)
 SPA= [498](#)
 SYSID= [498](#)
 WFI= [498](#)
 syntax diagram [498](#)

TRANSACT macro statement
 for Fast Path [23](#)

TRANSACT macro statement (*continued*)

- INQUIRY keyword [115](#)
- keywords for Fast Path transactions [115](#)
- MSGTYPE keyword [115](#)
- PROCLIM keyword [115](#)
- PRTY keyword [119](#)
- transaction codes
 - specifying [498](#)
- transactions
 - configuring [113](#)
 - deleting [74](#)
 - deleting dynamically [74](#)
 - deleting with DRD [74](#)
 - examples of grouping [117](#)
 - Fast Path
 - defining characteristics [115](#)
 - recommended keywords [113](#)
 - scheduling in parallel [124](#)
 - scheduling using suspend queue [122](#)
 - stopped due to 10 U3303 abends [122](#)
 - stopping [117](#)
 - storage in resource structure [237](#)
- TRCLEV
 - BPE trace table statements [665](#)
 - BPE trace table types [665](#)
 - members of the IMS PROCLIB data set [665](#)
 - parameters [665](#)
 - RM trace table types [665](#)
- TRN= parameter [581](#)
- TRN= parameter for procedures [581](#)
- TRUNC= parameter [736](#)
- TSO
 - IMS Connect
 - allocating log record data sets [307](#)
 - TSO browsing, IMS support of [166](#)
- TSR= parameter [581](#)
- TSR= parameter for procedures [581](#)
- tuning considerations
 - control program address spaces [105](#)
- Type 2 SVC [131](#)
- Type 4 SVC [131](#)
- TYPE macro
 - description [514](#)
 - MFS [173](#)
 - parameters
 - BACKUP= [514](#)
 - EDIT= [514](#)
 - OPTIONS= [514](#)
 - UNITYPE= [514](#)
 - syntax diagram [514](#)
- TYPE= parameter
 - DATASET [417](#)
 - DFSDCMON [417](#)
 - DFSMMDA [417](#)
 - FINAL [417](#)
 - FPDEDB [417](#)
 - IMSACB [417](#)
 - INITIAL [417](#)
 - OLCSTAT [417](#)
 - OLDS [417](#)
 - RECON [417](#)
 - SLDS [417](#)

U

- U3303abend
 - stopping transactions and PSBs after ten U3303 abends [122](#)
- UHASH= parameter [581](#)
- UHASH= parameter for procedures [581](#)
- UHTS= parameter [581](#)
- UHTS= parameter for procedures [581](#)
- UJCL1= parameter [437](#)
- UJCL2= parameter [437](#)
- UJCL3= parameter [437](#)
- UJCL4= parameter [437](#)
- UJCL5= parameter [437](#)
- UJCLx= parameter [437](#)
- UM (undefined record format) [166](#)
- UMAC0= parameter [437](#)
- UMAC1= parameter [437](#)
- UMAC2= parameter [437](#)
- UMAC3= parameter [437](#)
- undefined record format [166](#)
- UNIT= parameter
 - DFSMMDA TYPE=DFSCMON statement [421](#)
- UNITYPE= parameter [450](#), [514](#), [821](#)
- Universal drivers
 - configuring IMS support [309](#)
- UOM= parameter [728](#)
- UPDTPRT= parameter [437](#)
- user descriptors
 - format [815](#), [827](#)
 - parameters [815](#), [827](#)
 - syntax [815](#), [827](#)
- user exit list member of the IMS PROCLIB data set
 - BPE exit list member [684](#)
 - sample BPE [684](#)
 - sample CQS [684](#)
 - sample IMS Connect [684](#)
 - sample of combined [684](#)
 - sample OM [684](#)
 - sample RM [684](#)
 - sample SCI [684](#)
- user exit routine trace table (USRX) [665](#)
- user exit routines
 - DFSDFxxx [806](#)
- user exits
 - Structured Call Interface
 - initialization parameters [245](#), [723](#)
 - List member of the IMS PROCLIB data set [245](#), [724](#)
 - sample CSLSIxxx [725](#)
 - sample list member of the IMS PROCLIB data set [245](#), [725](#)
- User Queue Space Notification Exit routine [153](#)
- user-supplied exit routines
 - specifying owner's type [684](#)
- USERID= parameter [968](#)
- USERLIB= parameter [437](#)
- USERMSGs= parameter for procedures [581](#)
- USERVAR= parameter [582](#), [839](#)
- USERVAR= parameter for procedures [582](#)
- USRX (user exit routine trace table) [665](#)
- utilities
 - Dynamic Allocation [417](#)

V

VACBOPN= parameter [736](#)
VALCK= parameter [582](#)
VALCK= parameter for procedures [582](#)
VAUT, online execution parameter [180](#)
VAUT= parameter [582](#)
VAUT= parameter for procedures [582](#)
verifying stage 1 input [21](#)
VFREE= parameter [582](#)
VFREE= parameter for procedures [582](#)
VSAM
 buffer pools, defining
 dynamically [207](#), [209](#)
 buffers
 adjusting [206](#)
 adjusting dynamically [206](#)
 dynamic database buffer pools
 DFSDFxxx [810](#)
 performance options, defining [866](#)
 subpools
 defining [209](#)
 subpools, defining [863](#)
VSAM (Virtual Storage Access Method)
 data sets [156](#)
VSAM_BUFNO= parameter [911](#)
VSAM_BUFSIZE= parameter [911](#)
VSFX= parameter [582](#)
VSFX= parameter for procedures [582](#)
VSPEC= parameter [582](#)
VSPEC= parameter for procedures [582](#)
VTAM
 COMM macro, and [408](#), [412](#)
 data communication macros
 COMM [125](#)
 NAME [125](#)
 SUBPOOL [125](#)
 TERMINAL [125](#)
 TYPE [125](#)
 VTAMPOOL [125](#)
 macro statements [360](#), [361](#), [363](#), [366–369](#)
 using multi-node persistent sessions (MNPS) to take over terminals [834](#)
VTAM terminals
 dynamic [132](#)
 dynamic allocation [132](#)
 effect of system definition process on [132](#)
 static [132](#)
 static definition [132](#)
 using multi-node persistent sessions (MNPS) to take over [748](#)
 when multi-node persistent sessions (MNPS) are used rather than XRF [408](#)
VTAMPOOL macro [516](#)

W

WADS [150](#)
WADS (write-ahead data set)
 allocating [147](#)
WADS= parameter [187](#)
wait-for-input (WFI) mode [121](#)
warm start
 impact on resource definitions [37](#)

warm start (*continued*)
 resuming an online reorganization for HALDBs [887](#)
WFI (wait-for-input) mode [121](#)
WFI= parameter [498](#)
WKAP= parameter [583](#)
WKAP= parameter for procedures [583](#)
write-ahead data set [147](#)
writing trace tables [344](#)
WTORUSID= parameter [736](#)

X

X'22' log records [33](#)
XCF_GROUP_NAME= parameter [911](#)
XCF_THREADS= parameter [911](#)
XIBAREA [917](#)
XML
 adapter [303](#)
 converter [303](#)
 data conversion
 into COBOL [303](#)
 into PL/I [303](#)
 IMS Connect
 conversion support [303](#)
 XML-to-COBOL conversion support
 configuring [303](#)
 example [303](#)
 prerequisites [303](#)
 restrictions [303](#)
 XML-to-PL/I conversion support
 configuring [303](#)
 example [303](#)
 prerequisites [303](#)
 restrictions [303](#)
XPLINK= parameter [583](#)
XPLINK= parameter for procedures [583](#)
XRF
 COMM macro
 APPLID parameter [408](#)
 PASSWD parameter [412](#)
 DFSHSBxx PROCLIB member [834](#)
 restrictions [153](#)
XRF considerations
 change list processing [44](#)

Y

YEAR4= parameter [583](#)
YEAR4= parameter for procedures [583](#)

Z

z/OS
 IMS procedures, and [210](#)
 IMSRDR procedures, and [210](#)
 master trace table
 size recommendations [337](#)
 program properties table
 updating [25](#)
 system trace table
 size recommendations [337](#)
z/OS setup recommendations
 Automatic Dump Data set Allocation [338](#)

z/OS setup recommendations (*continued*)

CHNGDUMP MAXSPACE [338](#)

common storage tracker [337](#)

z/OS system trace table [339](#)

z/OSMF (IBM z/OS Management
Facility)

DEDB database [236](#)

Fast Path DEDB [236](#)

IMS system [235](#)

provision

DEDB database [236](#)

IMS system [235](#)



Product Number: 5635-A06
5655-DS5
5655-TM4